

An Introduction to Robotics

Dr. Bob Williams, williar4@ohio.edu

Mechanical Engineering, Ohio University

EE/ME 4290/5290 Mechanics and Control of Robotic Manipulators

© 2021 Dr. Bob Productions



Introduction to Robotics Table of Contents

BRIEF HISTORY OF ROBOTICS	3
PHOTO GALLERY	8
DEFINITIONS	18
APPLICATIONS	20
COMMON ROBOT DESIGNS	21
TRANSLATIONAL ARM DESIGNS	21
ORIENTATIONAL WRIST DESIGNS	23
MOBILE ROBOTS	26
HUMANOID ROBOTS	28
PARALLEL ROBOTS	29
CABLE-SUSPENDED ROBOTS	30
SOFT ROBOTS	31
ROBOT PARTS	34
TECHNICAL ROBOTICS TERMS	35
ACCURACY, REPEATABILITY, AND PRECISION EXAMPLE	36
ROBOT POWER SOURCES/ ACTUATORS	38
ROBOT END-EFFECTORS	39
ROBOT CONTROL METHODS	44
ROBOT SENSORS	46

Brief History of Robotics

- Leonardo da Vinci created many human-inspired, robot-like sketches, designs, and models in the 1500s.

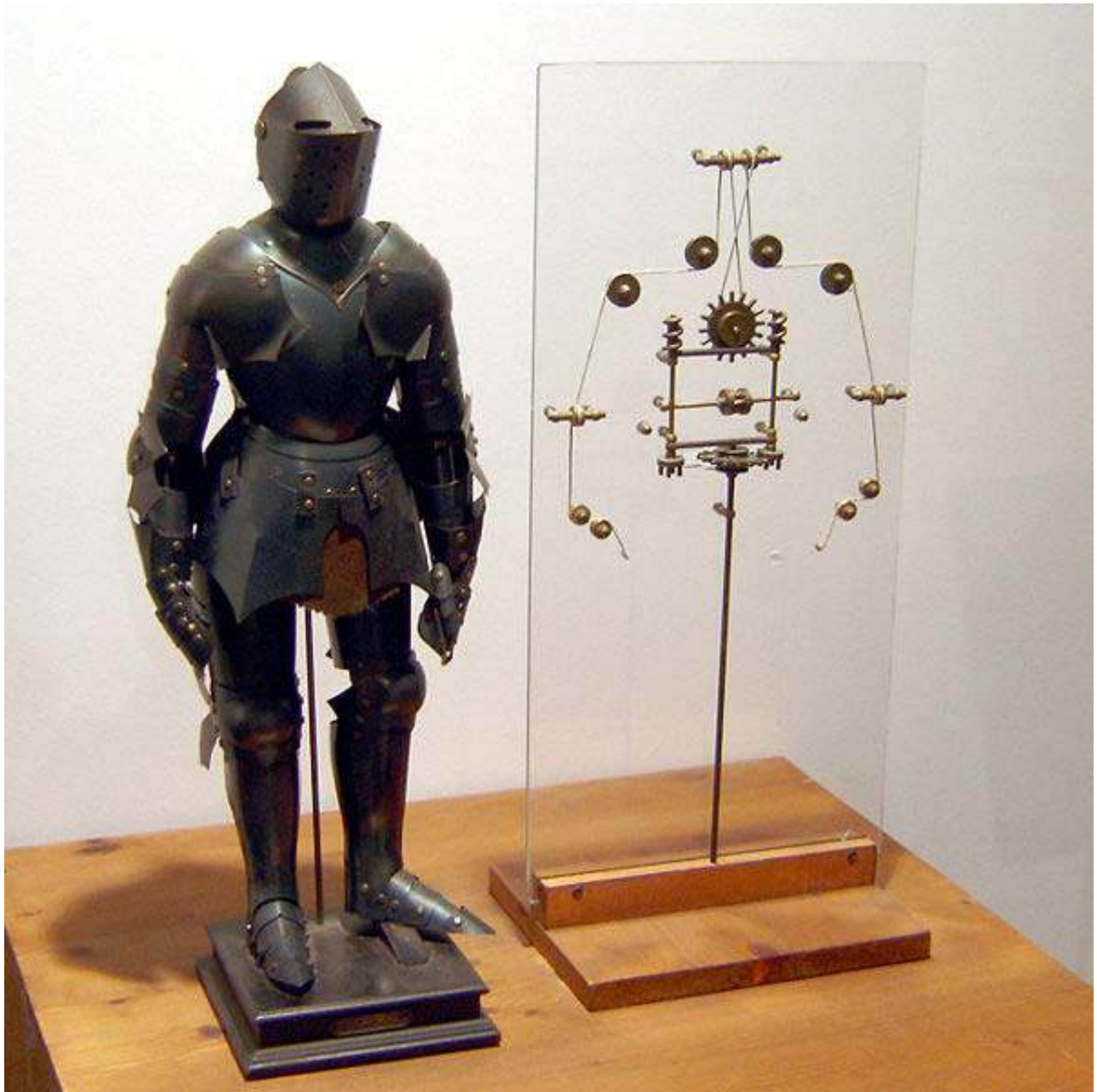

Leonardo Humanoid Robot with Internal Mechanisms

- The word **robot** first appeared in print in the 1920 play R.U.R. (Rossum's Universal Robots) by **Karl Kapek**, a Czechoslovakian playwright. **Robota** is Czechoslovakian for *worker* or *serf* (peasant). Typical of early science fiction, the robots take over and exterminate the human race.



Rossum's Universal Robots (R.U.R.)

“When he (Young Rossum) took a look at **human anatomy** he saw immediately that it was too complex and that a good engineer could simplify it. So he undertook to redesign anatomy, experimenting with what would lend itself to omission or simplification. Robots have a phenomenal memory. If you were to read them a twenty-volume encyclopedia they could repeat the contents in order, but they never think up anything original. They'd make fine university professors.”

– Karel Capek, R.U.R. (Rossum's Universal Robots), 1920

- **Isaac Asimov** coined and popularized the term **robotics** through many science-fiction novels and short stories. Asimov was a visionary who envisioned in the 1930s a positronic brain for controlling robots; this pre-dated digital computers by a couple of decades. Unlike earlier robots in science fiction, robots do not threaten humans since Asimov invented the **Three Laws of Robotics**:

1. A robot may not harm a human or, through inaction, allow a human to come to harm.
2. A robot must obey the orders given by human beings, except when such orders conflict with the First Law.
3. A robot must protect its own existence as long as it does not conflict with the First or Second Laws.

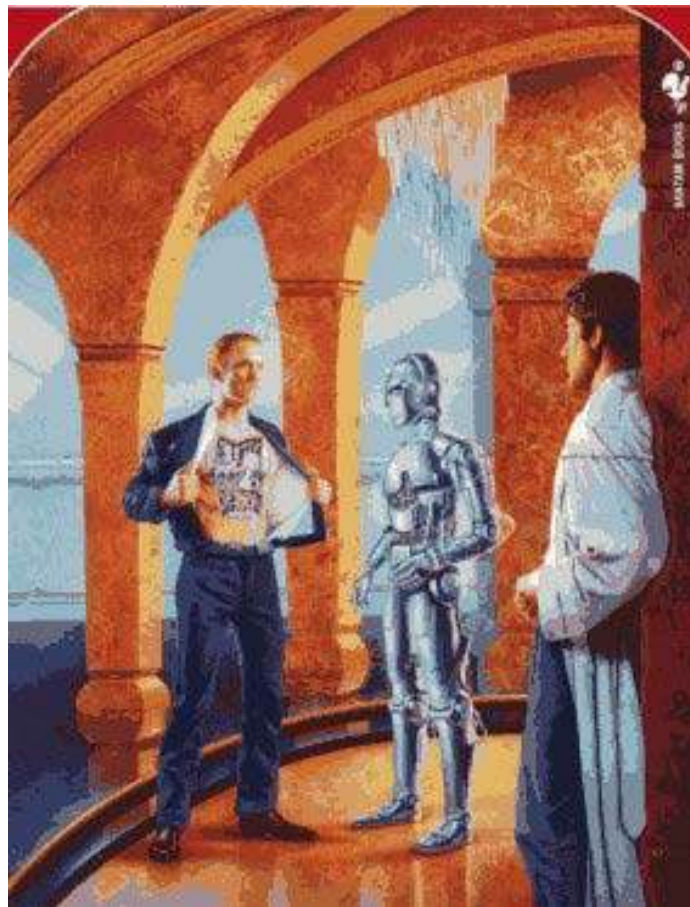

Asimov Humanoid Robots

“The division between human and robot is perhaps not as significant as that between intelligence and non-intelligence.”

–R. Daneel Olivaw, *The Caves of Steel*, Isaac Asimov

- **Joseph Engleberger** and **George Devoe** were the fathers of industrial robots. Their company, Unimation, built the first industrial robot, the **PUMA** (**P**rogrammable **U**niversal **M**anipulator **A**rm, a later version shown below), in 1961, inspired by the human arm.



PUMA Industrial Robot

GETTING SMARTER

Some of the earliest robots of the mid-20th century were devices mostly controlled by nearby humans or were simple tools able to perform limited tasks.

Robot autonomy

- Remotely operated
- ◇ Automated
- Artificial Intelligence

Year marks date of commercialization or extensive use. Illustrations are not to scale.

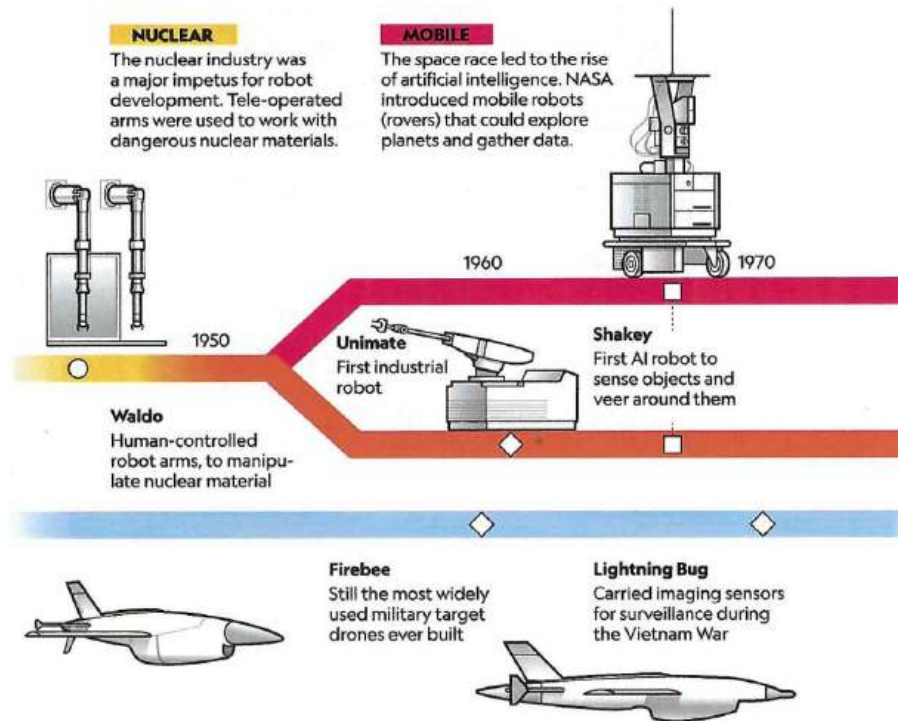

Robot History Timeline, 1950s – 1970s

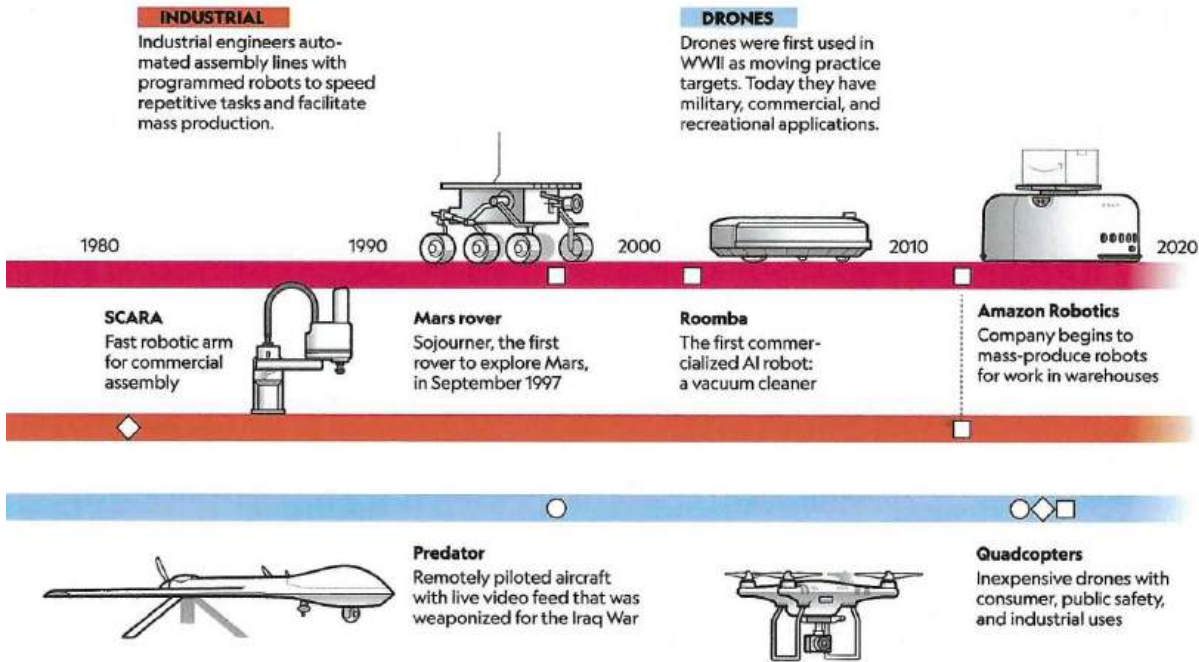

Robot History Timeline, 1980s – 2020s

National Geographic Magazine, September 2020

What did they miss? **In-Parallel-Actuated Robots** and **Cable-Suspended Robots**.

Photo Gallery

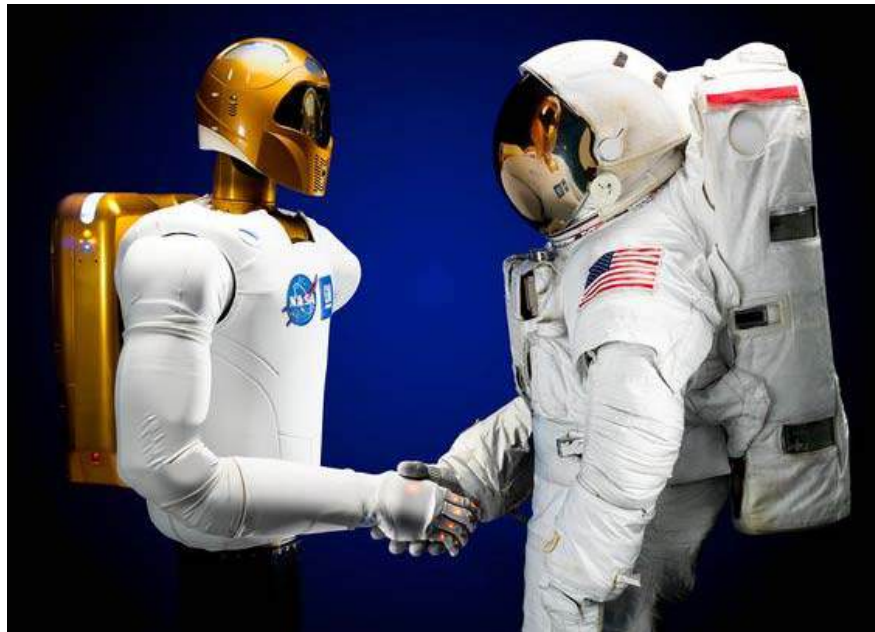

Robonaut and Human Astronaut



Robonaut on Rover



Human Astronaut on RMS

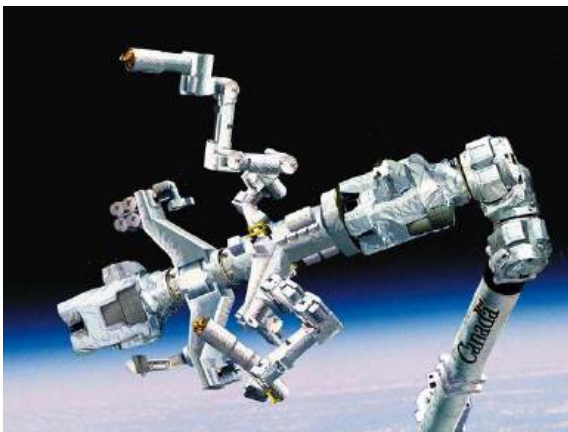

Dextre



Flight Telerobotic Servicer

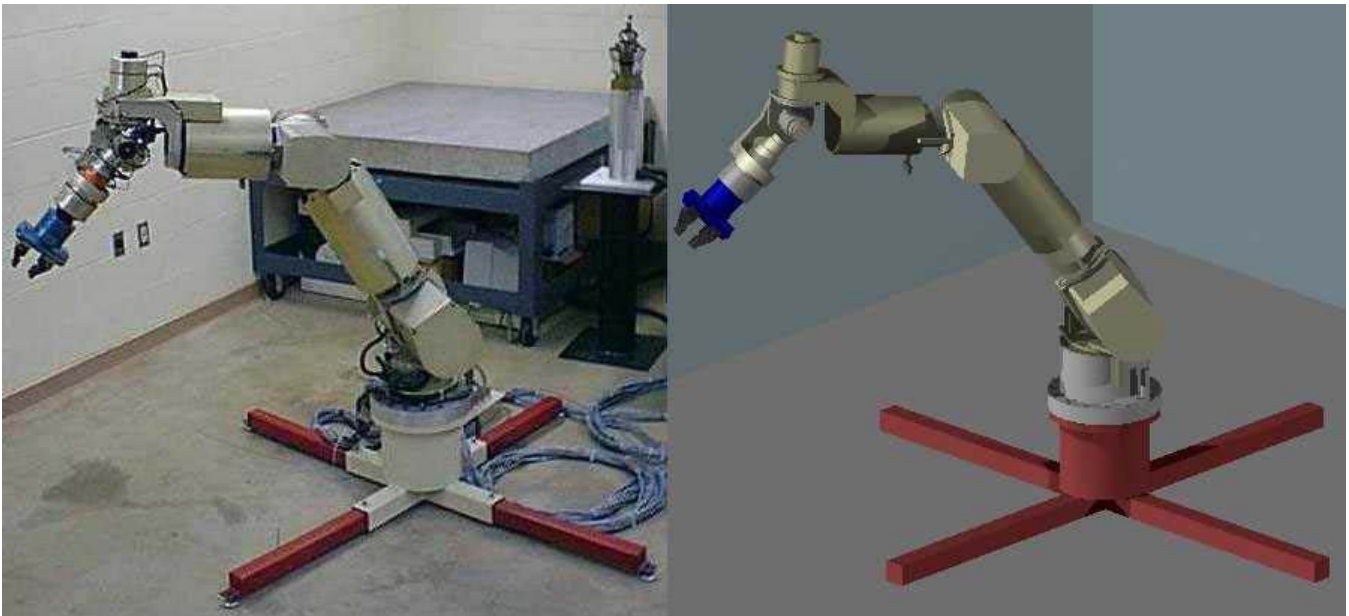

NASA LaRC 8-axis 8R Spatial Serial Manipulator



NASA LaRC 2 6-axis 6R PUMA Robots



Rosheim Omni Wrist

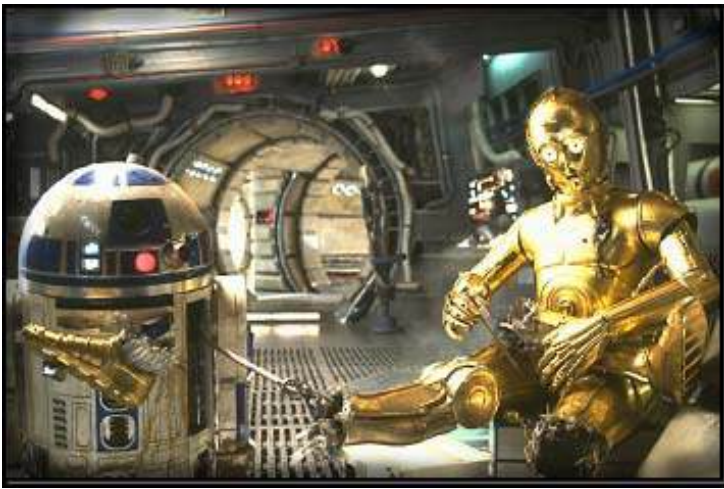

R2-D2 and C3PO



NASA JSC Robonaut

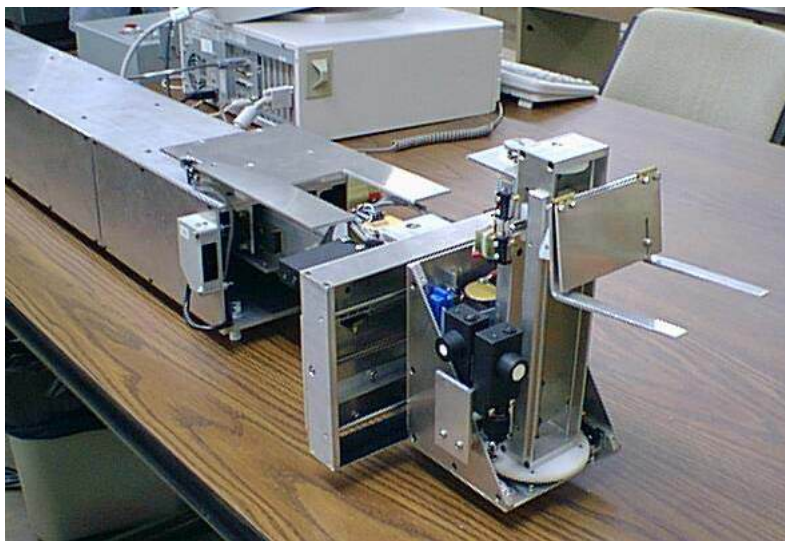

Stewart-Glapat 5-axis Trailer-Loading Robot



NASA KSC 18-dof Serpentine Truss Manipulator

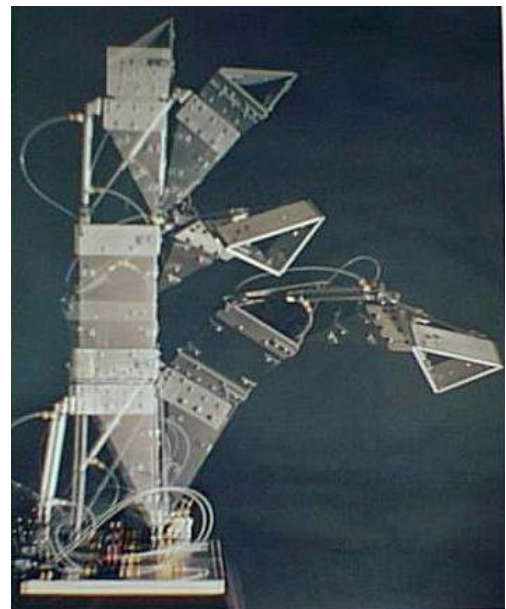

2 Modules (Rex Kuriger)



NASA LaRC 6R PUMA on Stewart Platform

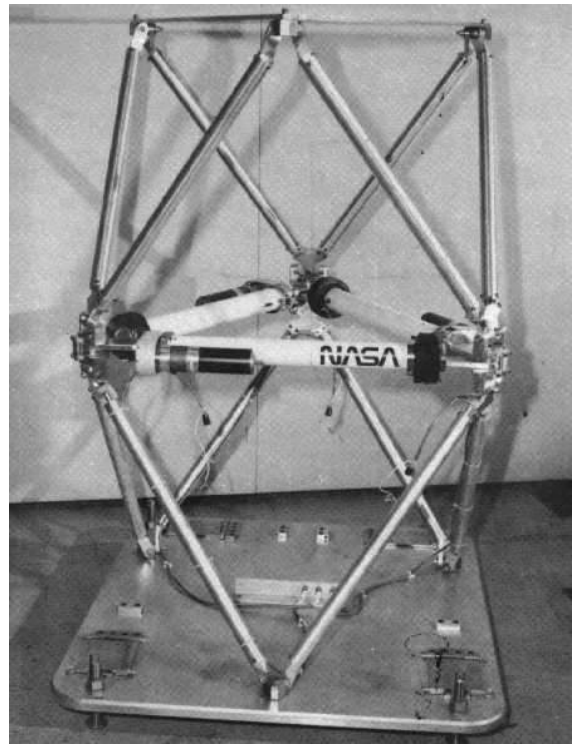

NASA Variable Geometry Truss

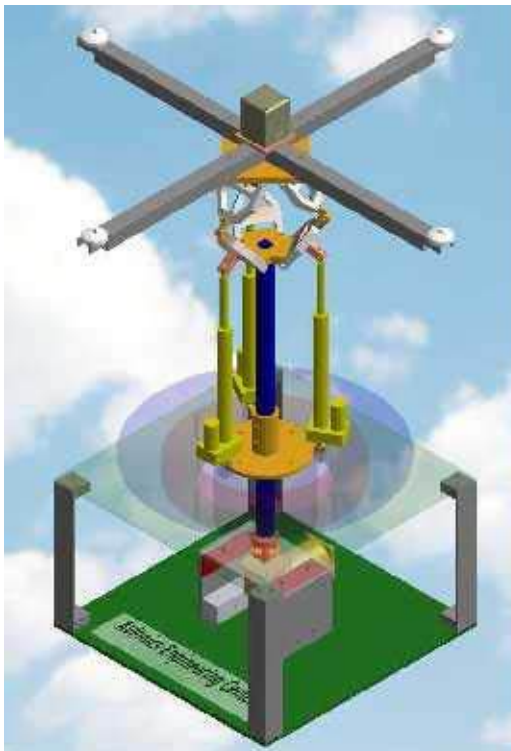

4-dof GPS/IMU Calibration Platform





6-dof 6-PUS Parallel Platform Manipulator

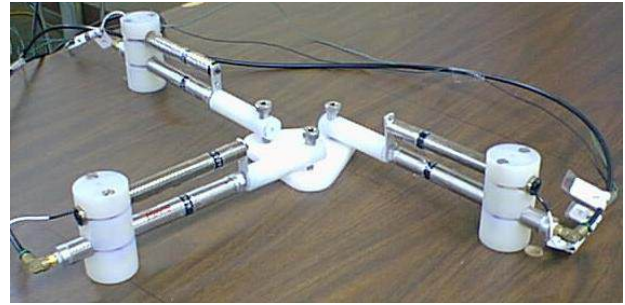

3-dof 3-RPR Parallel Platform Manipulator

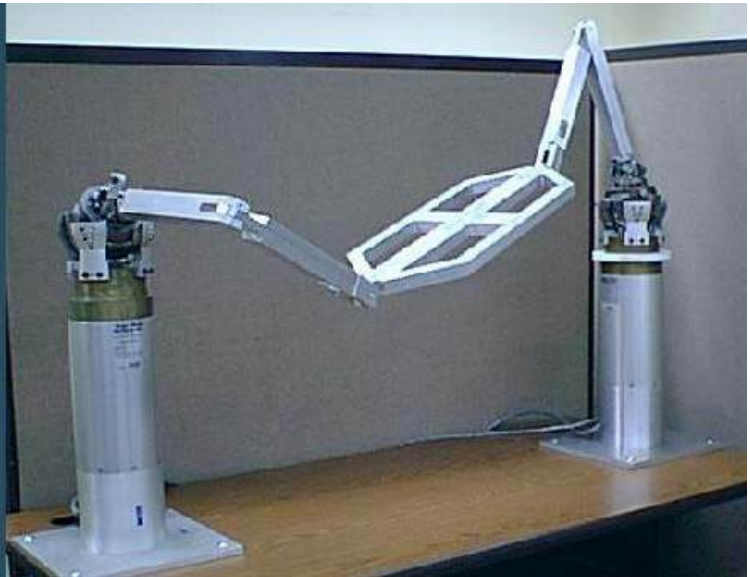
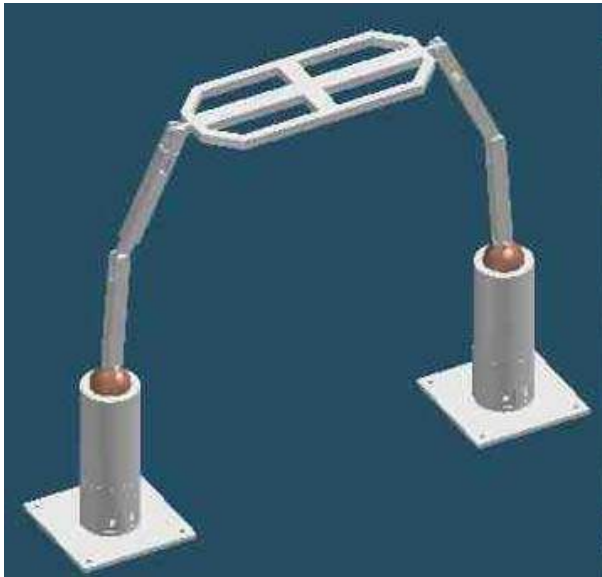

**6-dof 6-SRU Spatial Parallel Platform Manipulator
with Rosheim Omni-Wrist Actuators**

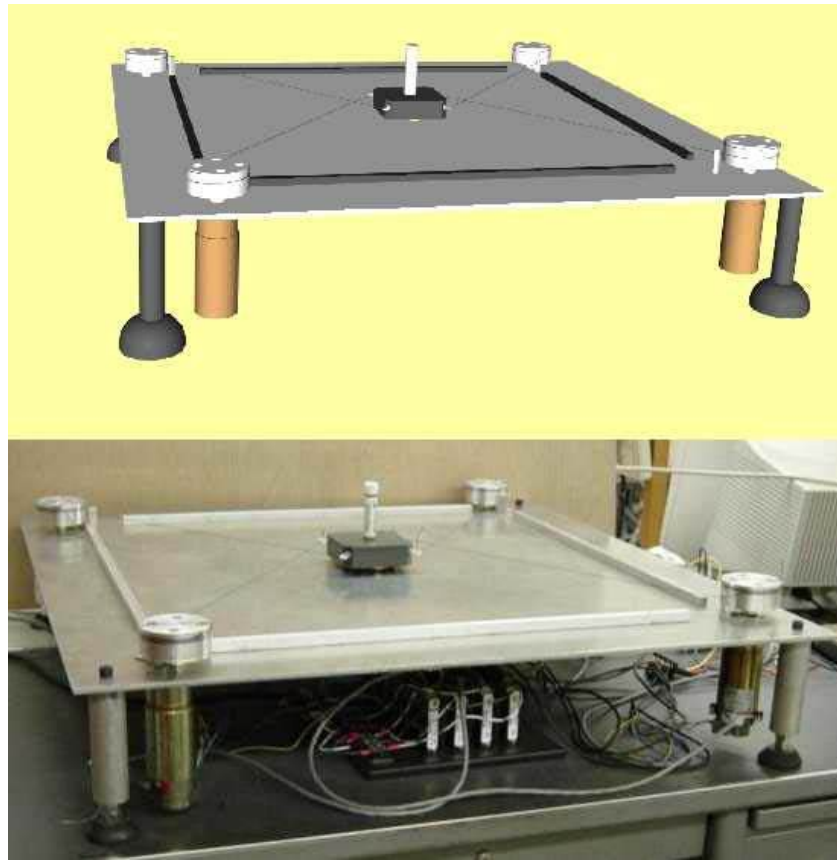

4-dof Planar Wire-Driven Robot



NIST 6-dof RoboCrane Cable Robot

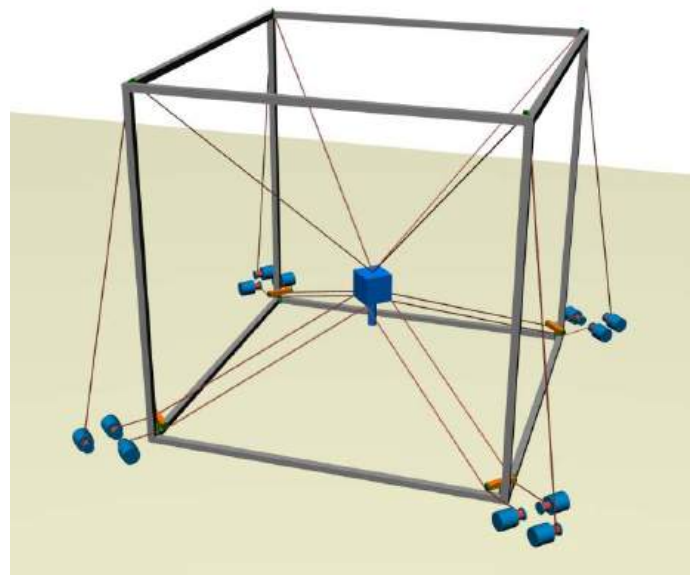

8-dof Cartesian Contour Crafting Cable Robot

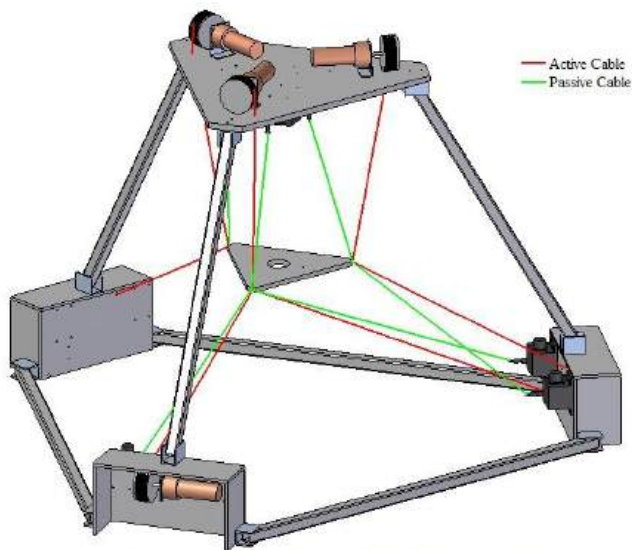

7-dof Spatial Cable-Suspended Robot

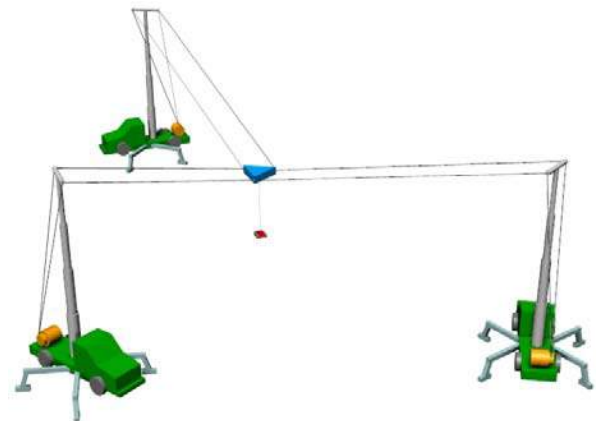

Deployable Search and Rescue Cable Robot



3-dof Cable-Suspended Haptic Interface



8-dof Cable-Suspended Haptic Interface

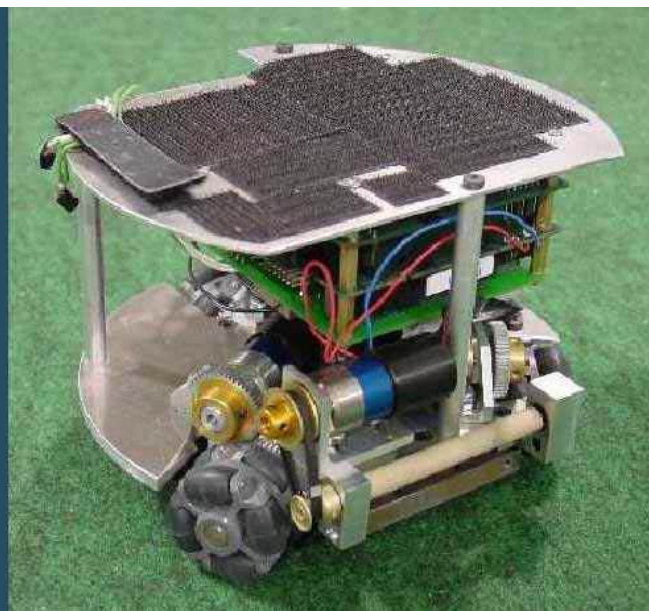
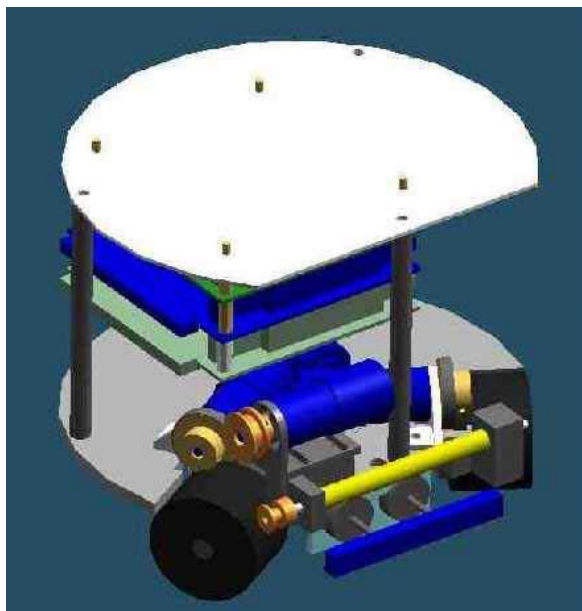

3-dof Omni-Directional RoboCup Wireless Autonomous Mobile Robot

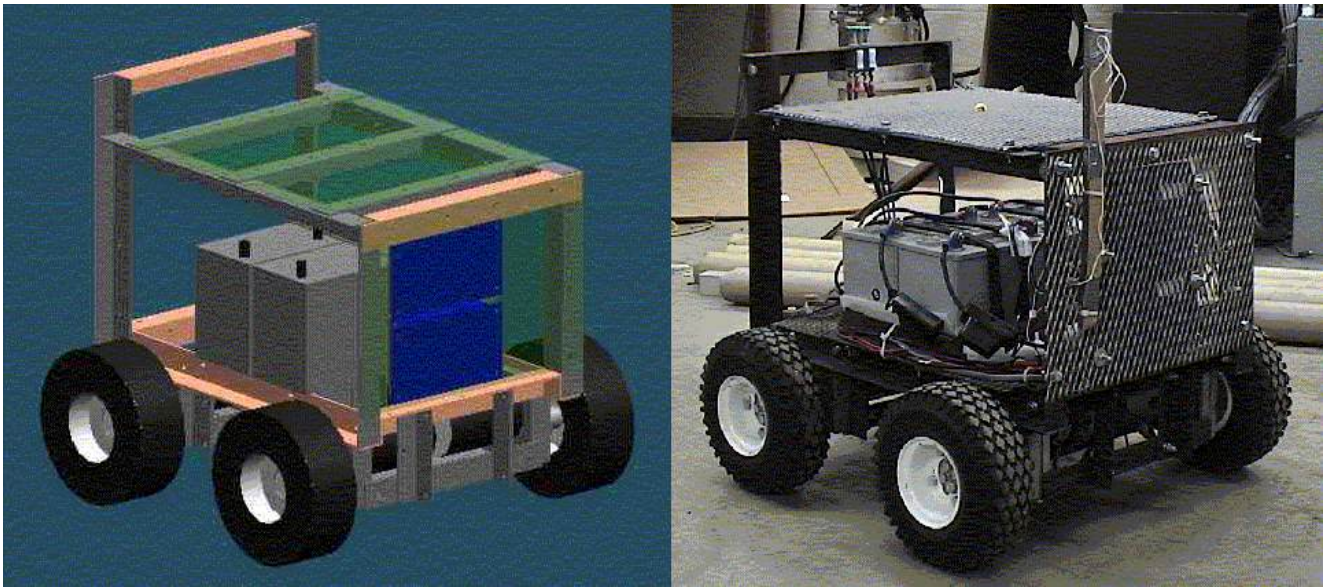

4-dof Search and Rescue Mobile Robot

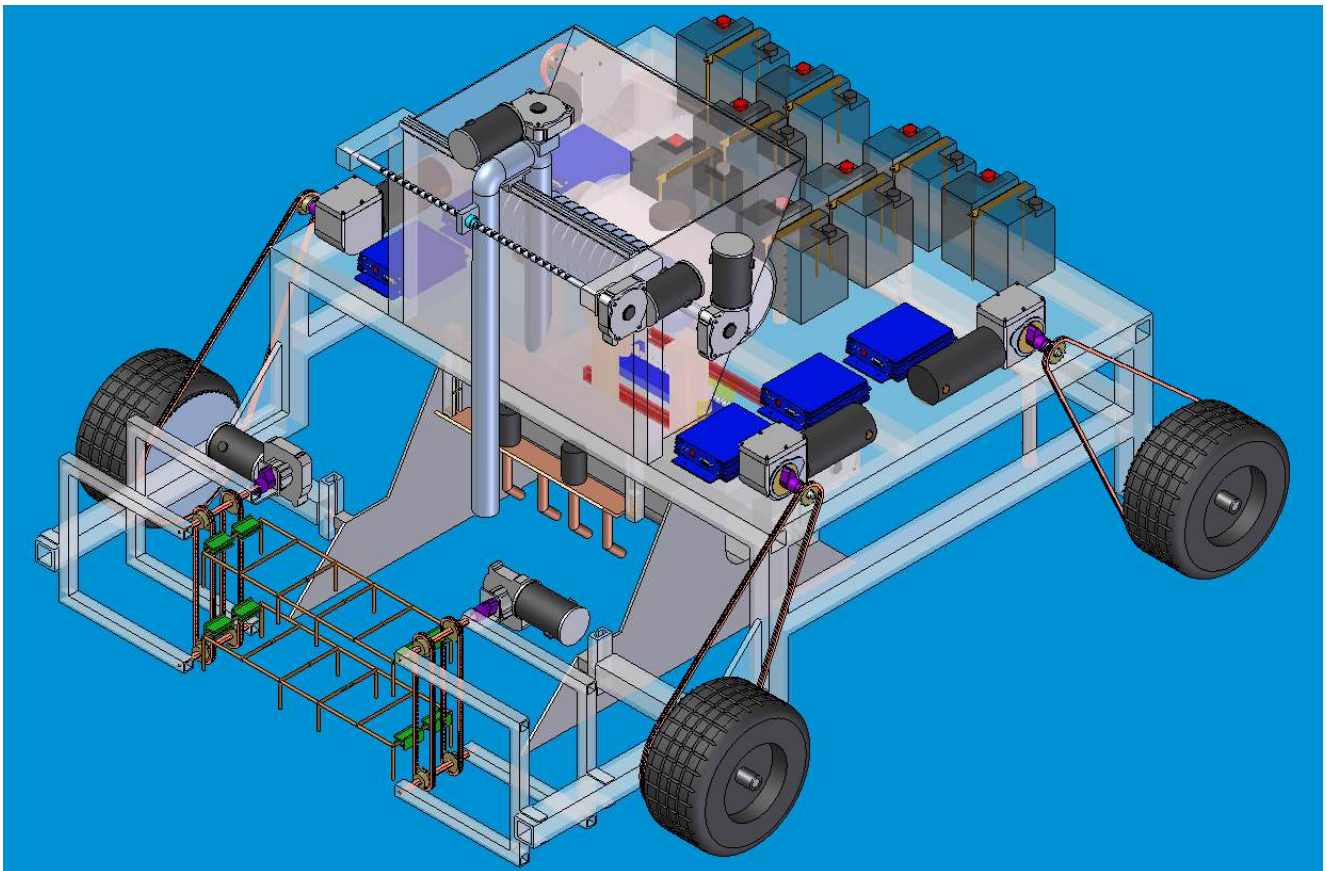

4-dof Autonomous Concrete-Paving Mobile Robot



Pop-Culture Droids and Humanoid Robots



Famous Pop-Culture Robot Heads/Faces (Daniel Nyari)

T800, Terminator	Astro Boy	Vision, Marvel Comics	Bender, Futurama	Brainiac, DC Comics
C3P0, Star Wars	Clank, Ratchet and Clank	Cyberman, Doctor Who	Cylon, Battlestar Galactica	Awesome-O 4000, South Park
GORT, The Day the Earth Stood Still	Rosie, The Jetsons	Alpha, Power Rangers	Voltron	EVE, WALL-E
Machine Man, Metropolis	Optimus Prime, Transformers	WALL-E	Wheatley, Portal 2	Marvin, Hitchhikers Guide to the Galaxy
Miles Monroe, Sleeper	HAL-9000, 2001: A Space Odyssey	The Iron Giant	Robby the Robot, Forbidden Planet	Pneuman, DC Comics
R2D2, Star Wars	Sentinel, Marvel Comics	ASIMO, Honda	H8, Magnus Robot Fighter	Megaman

Definitions

robot An electromechanical device with **multiple** degrees-of-freedom (**dof**) that is **programmable** to accomplish a variety of **tasks**.

What are examples of robots?

robotics The science of **robots**. Humans working in this area are called **roboticists**.

dof **degrees-of-freedom**, the number of independent motions a device can make. Also called **mobility**.

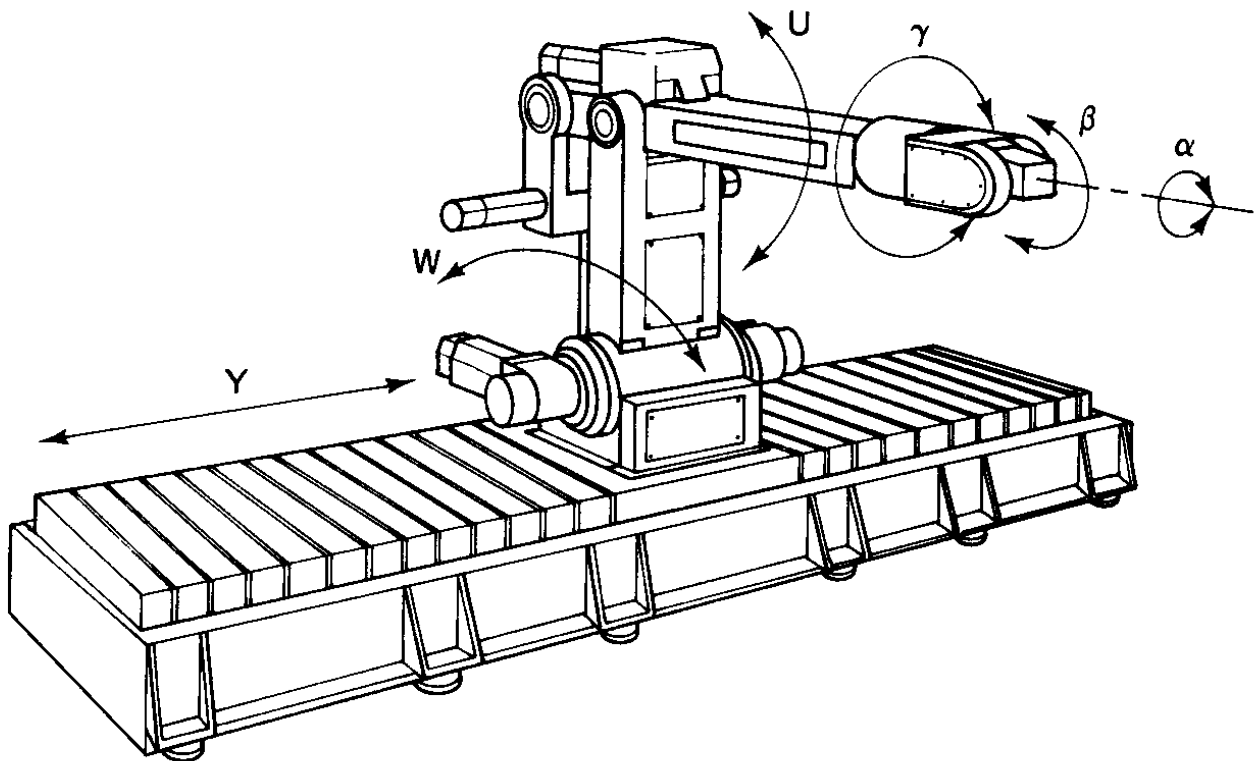

How many **dof** does the human arm have? The human leg?

manipulator Electromechanical device capable of interacting with its environment.

anthropomorphic Designed or appearing like human beings.

end-effector The tool, gripper, or other device mounted at the end of a **manipulator**, for accomplishing useful tasks.

workspace The volume in space that a robot's end-effector can reach, both in position and orientation.

position	The translational (straight-line) location of an object.
orientation	The rotational (angular) location of an object. An airplane's orientation is measured by roll , pitch , and yaw angles.
pose	position and orientation taken together.
link	A rigid piece of material connecting joints in a robot .
joint	The device which allows relative motion between two links in a robot .

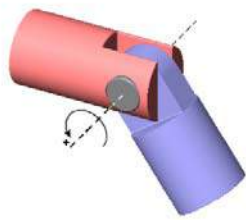

revolute (R)

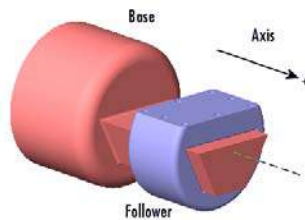

prismatic (P)

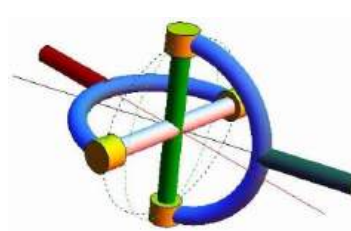

universal (U)

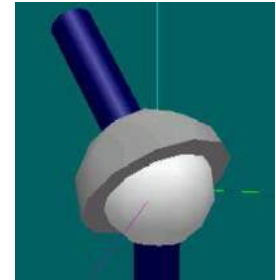

spherical (S)

Common Robot Joint Examples (1, 1, 2, and 3-dof, respectively)

kinematics	The study of motion without regard to forces/torques.
dynamics	The study of motion with regard to forces/torques.
actuator	Provides force/torque for robot motion.
sensor	Reads actual variables in robot motion for use in control.
haptics	From the Greek, meaning to touch . Haptic interfaces give human operators the sense of touch and forces from the computer, either in virtual or real, remote environments. Also called force reflection in telerobotics.

Applications

Traditionally, robots are applied anywhere one of the **3Ds** exist: in any job which is too **Dirty**, **Dangerous**, and/or **Dull** for a human to perform.

Industry

Industrial robots are used in manufacturing: pick & place, assembly, welding, spray painting, deburring, machining, etc.

Remote operations

Remote applications for robotics include undersea, nuclear environment, bomb disposal, law enforcement, and outer space.

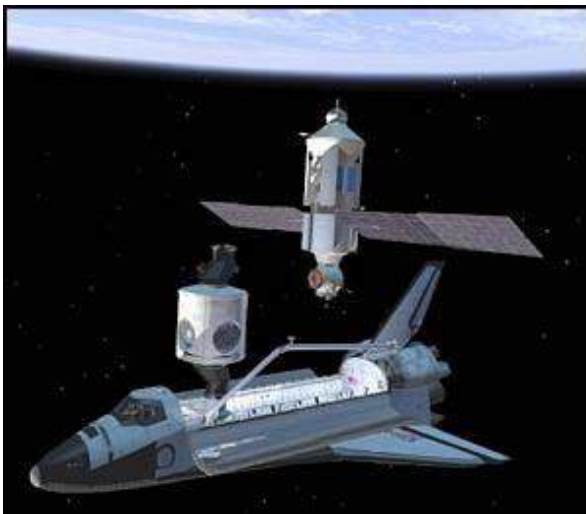
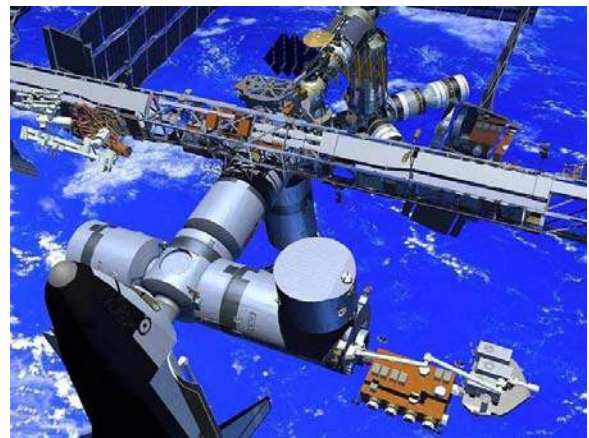

NASA Space Shuttle and International Space Station Robots

Service

Service robots have been implemented as hospital helpmates, handicapped assistance, retail, household servants, vacuum cleaners, and lawnmowers.

Common Robot Designs

Translational Arm Designs

Cartesian Robot

Cartesian robots have three linear axes of movement (X , Y , Z). They are constructed of three mutually-orthogonal P joints, with variable lengths L_1 , L_2 , L_3 . Used for pick and place tasks and to move heavy loads. Also called Gantry Robots, they can trace rectangular volumes in 3D space.

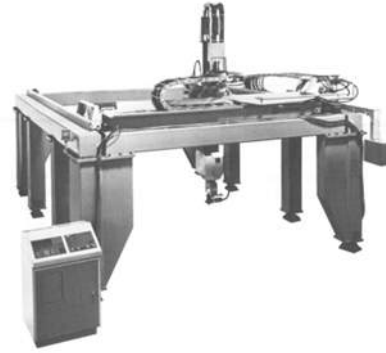
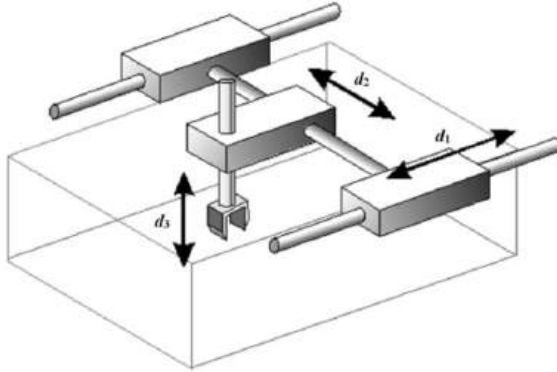

Cylindrical Robot

Cylindrical robot positions are controlled by a variable height L_1 , an angle θ_2 , and a variable radius L_3 (P joint, R joint, P joint). These robots are commonly used in assembly tasks and can trace concentric cylinders in 3D space.

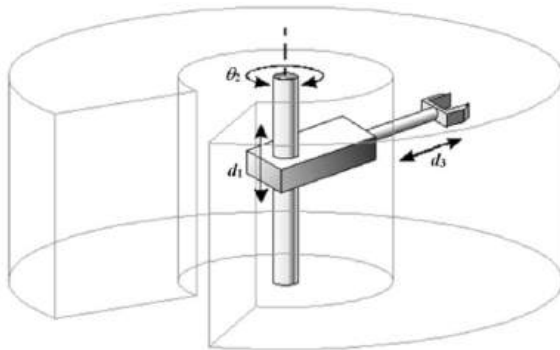

Spherical Robot

Spherical robots have two orthogonal rotational R axes, with variables θ_1 and θ_2 , and one P joint, variable radius L_3 . The robots' end-effectors can trace concentric spheres in 3D space.

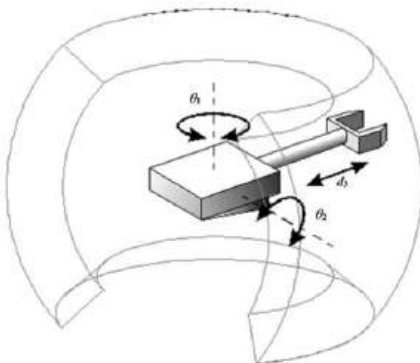

SCARA (Selective Compliance Articulated Robot Arm) Robot

SCARA robots have two **R** joints θ_1 and θ_2 , plus a **P** joint d_3 perpendicular to that plane of motion, to achieve a 3D xyz workspace. **R** joint angle θ_4 is the single-rotation SCARA robot wrist. These are common table-top assembly robots.

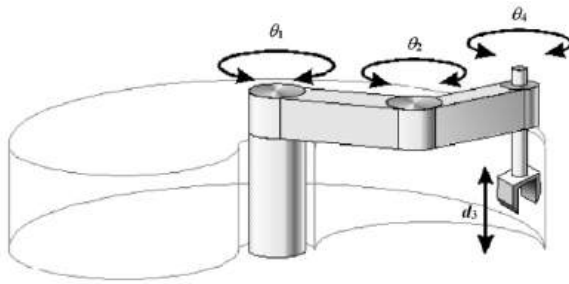

Articulated Robot

Articulated robots resemble the human arm in their 3D motion (they are anthropomorphic). They have three R joints, with three variable angles θ_1 , θ_2 , and θ_3 , representing the human body waist, 1-dof shoulder, and elbow joints. They are versatile robots, but have more difficult kinematics and dynamics control equations than other serial robots. All of these robot architectures may be used with a variety of robot wrists to provide the orientation dof. A wrist pitch, with variable angle θ_4 , is also shown with the articulated robot below.

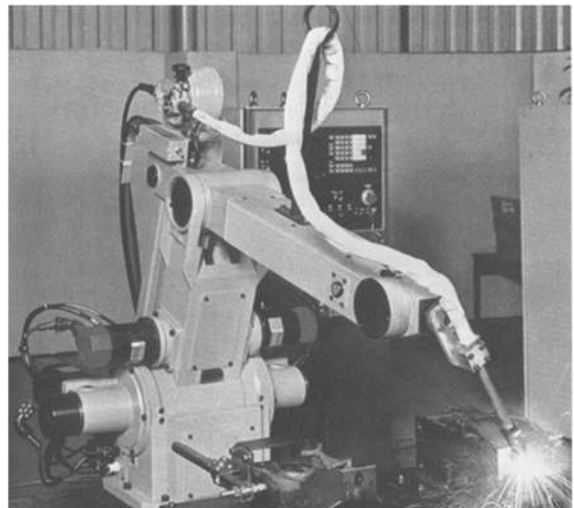
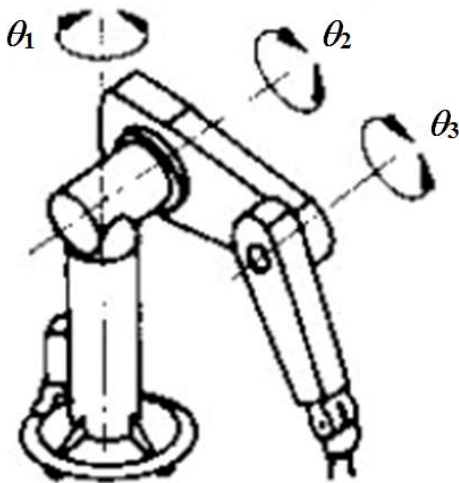

Oriental Wrist Designs

The standard robot designs presented in the previous subsection focus on the primary xyz translational motion for manipulators. Exception: the entire SCARA robot is shown, including its single wrist roll joint θ_4 .

The current subsection presents some common robot wrist designs to provide primary rotational motion of the robot end-effector. These are mounted on the end of the 3-dof translational robot arms to form serial robots with translational and rotational capability.

Note I write ‘primary’ above because the 3 translational joints also cause rotations and also the 3 wrist joints can cause translations of the tool. If the robot wrist design is spherical, i.e. with three joint axes intersecting in a single point, the translational and rotational motion of the robot may be decoupled for simpler kinematics equations and control.

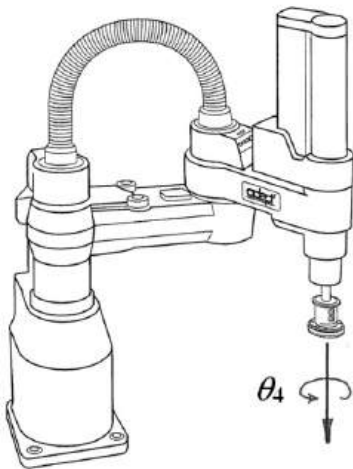

SCARA 1-dof roll wrist

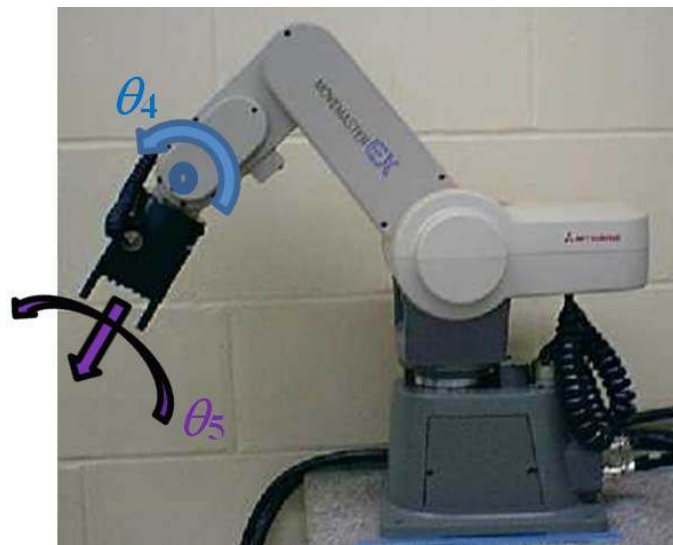

Mitsubishi 2-dof pitch-roll wrist

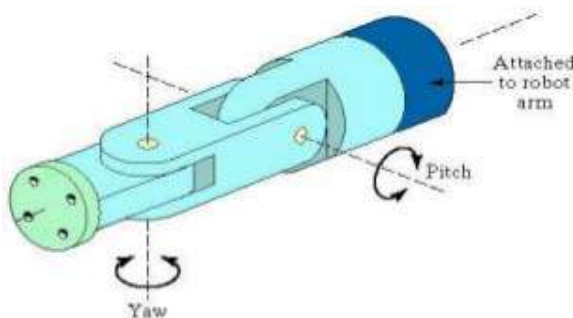

Offset 2-dof pitch-yaw wrist for axisymmetric tasks

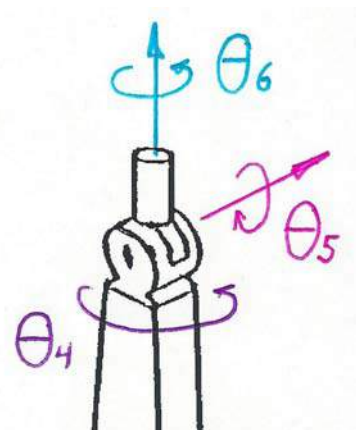

PUMA 3-dof roll-pitch-roll wrist

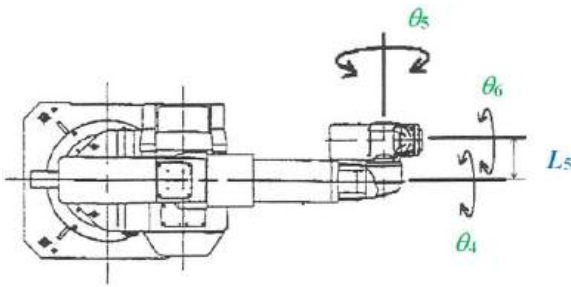

**Fanuc S10 offset 3-dof
roll-pitch-roll wrist**

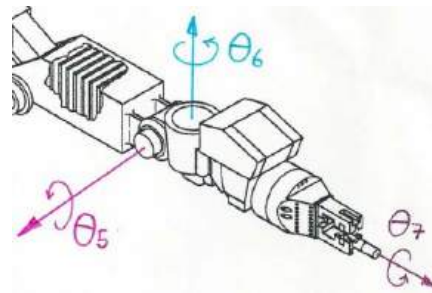

**FTS offset 3-dof
pitch-yaw-roll wrist**

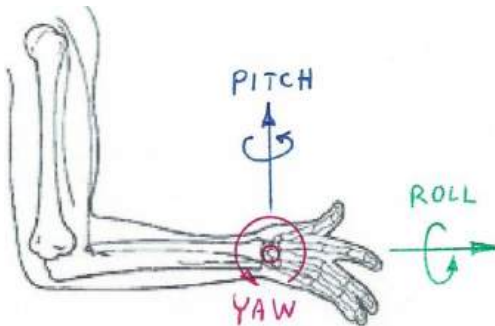

**Human 3-dof yaw-pitch-roll
Wrist**



**3-dof Rosheim singularity-free
pitch-yaw-roll Omni Wrist**

The Rosheim Omni Wrist has a singularity-free 3-dof pitch-yaw-roll design. In this case the rotations all occur independently, i.e. the pitch-yaw-roll order is arbitrary. There are singularities with this wrist design, but they are designed to lie in the forearm, outside of the joint limits. The Omni Wrist has a large rotational workspace, with both pitch and yaw axes rotating $\pm 90^\circ$ independently, and the roll axis with a huge $\pm 360^\circ$ capability. The Omni Wrist can also be equipped with an additional, unlimited bidirectional roll motion for actuating rotating tools, within the existing wrist.

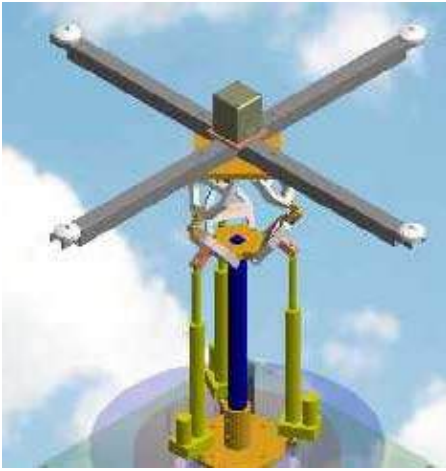

VGT 3-dof roll-pitch-yaw parallel wrist



OU 3-dof roll-pitch-yaw parallel wrist

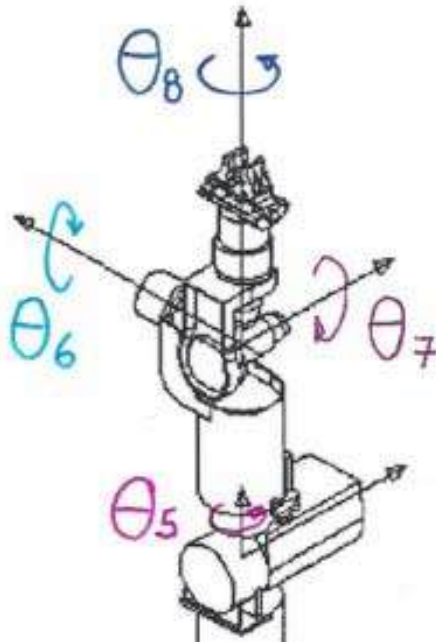

AAI ARMII 4-dof roll-yaw-pitch-roll wrist

Mobile Robots

Mobile robots have wheels, legs, or other means to navigate around the workspace under control. Mobile robots are applied as hospital helpmates, vacuum cleaners, lawn mowers, among other possibilities. These robots require good sensors to see the workspace, avoid collisions, and get the job done. The following six images show Ohio University's involvement with mobile robots playing soccer, in the international *RoboCup* competition (robocup.org).

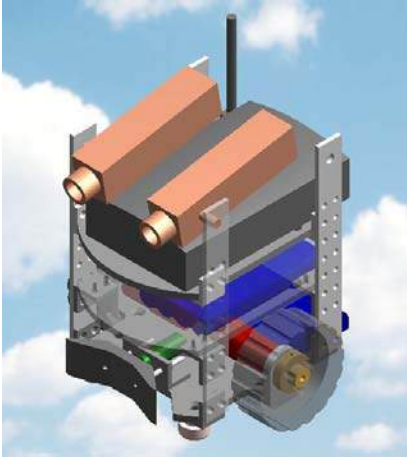

Early Conceptual Design

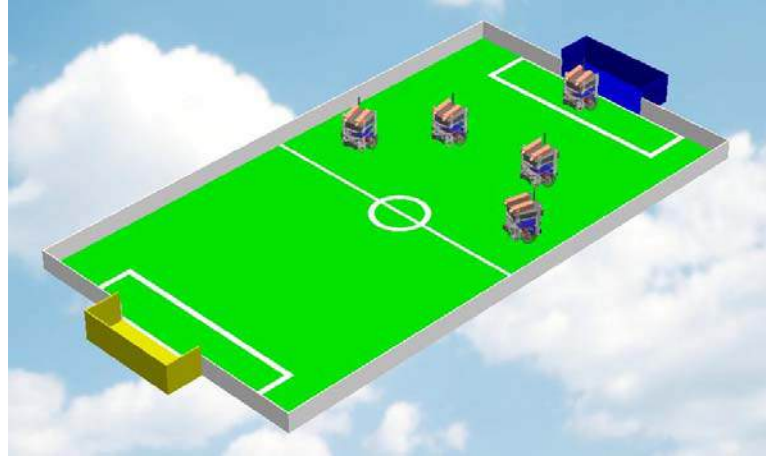

RoboCup Playing Field; 4 Players and 1 Goalie

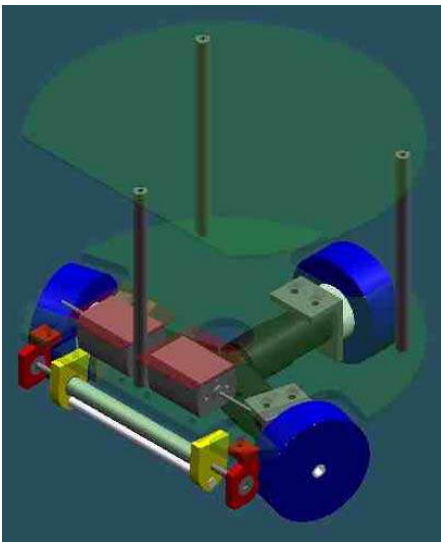

RoboCup Player CAD Model

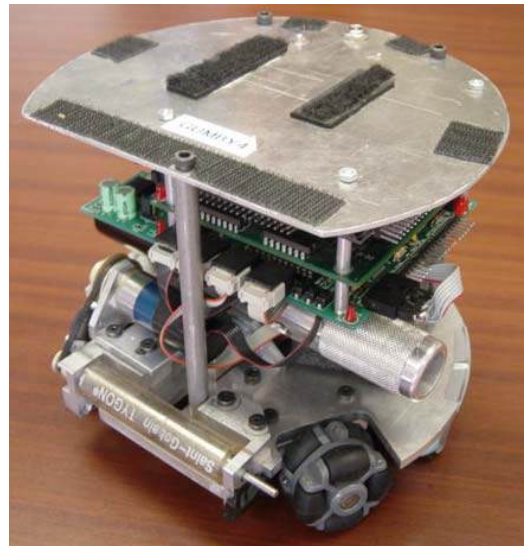

RoboCup Player Hardware

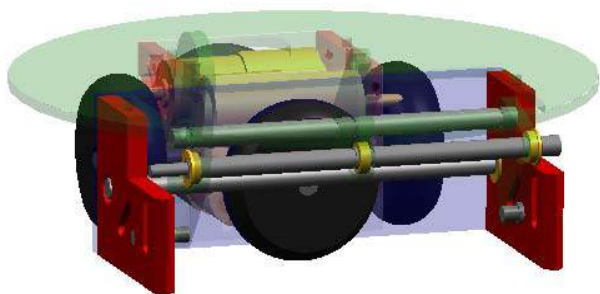

RoboCup Goalie CAD Model

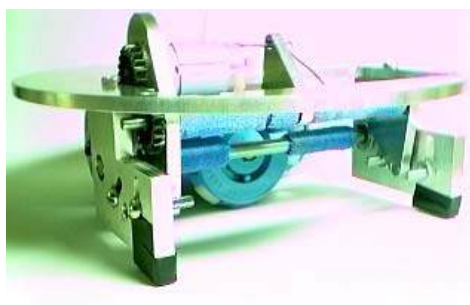

RoboCup Goalie Hardware



Lawn Mower Robot



Vacuum Cleaner Robot

Humanoid Robots

Many young students (and U.S. Senators) expect to see C3PO (from Star Wars) walking around when visiting a robotics laboratory. Often they are disappointed to learn that the state-of-the-art in robotics still largely focuses on robot arms. There is much current research work aimed at creating human-like robots that can walk, talk, think, see, touch, etc. Generally Hollywood and science fiction lead real technology by at least 20 or 30 years.

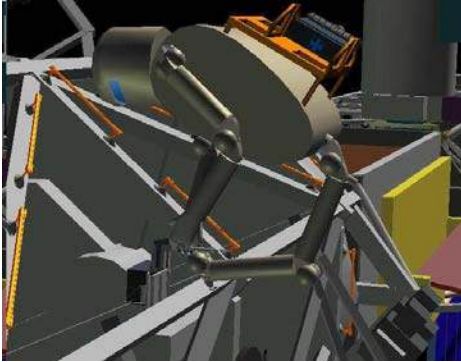

NASA JSC Robonaut



Honda Humanoid Robot



DARwIn-OP 20R 20-dof Humanoid Mobile Walking/Soccer Robot

height 455 mm (about 18 inches)
 mass 2.8 kg (just over 6 pounds weight)

2-dof pan/tilt head, two 3-dof arms, two 6-dof legs

autonomous and self-contained, on-board sensors, face-down and back-down recovery modes

Parallel Robots

Most of the robots discussed so far are serial robot arms, where joints and links are constructed in a serial fashion from the base, with one path leading out to the end-effector. In contrast, parallel robots have many arms with active and passive joints and links, supporting the load in parallel. Parallel robots can handle higher loads with greater accuracy, higher speeds, and lighter robot weight; however, a major drawback is that the workspace of parallel robots is severely restricted compared to equivalent serial robots. Parallel robots are used in expensive flight simulators, as machining tools, and can be used for high-accuracy, high-repeatability, high-precision robotic surgery.

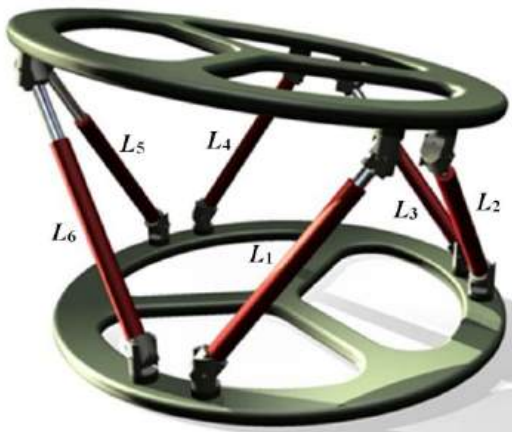

Stewart Platform Parallel Robot



Parallel Platform Robot at Ohio University

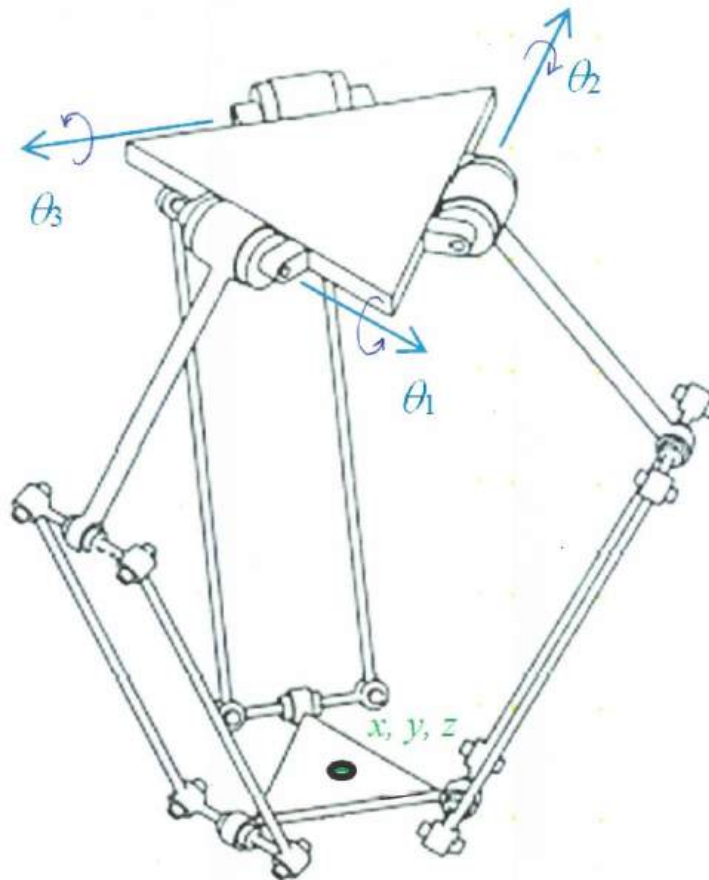

Delta 3-dof Translational Parallel Robot

Cable-Suspended Robots

Cable-suspended robots, pictured below, are a special kind of parallel robot where lightweight, stiff, strong cables are both the actuators and structure for the robot. Though a disadvantage is you cannot push on a cable (you can apply only tension), cable-suspended robots have large, even huge, translational workspaces, unlike most parallel robots.

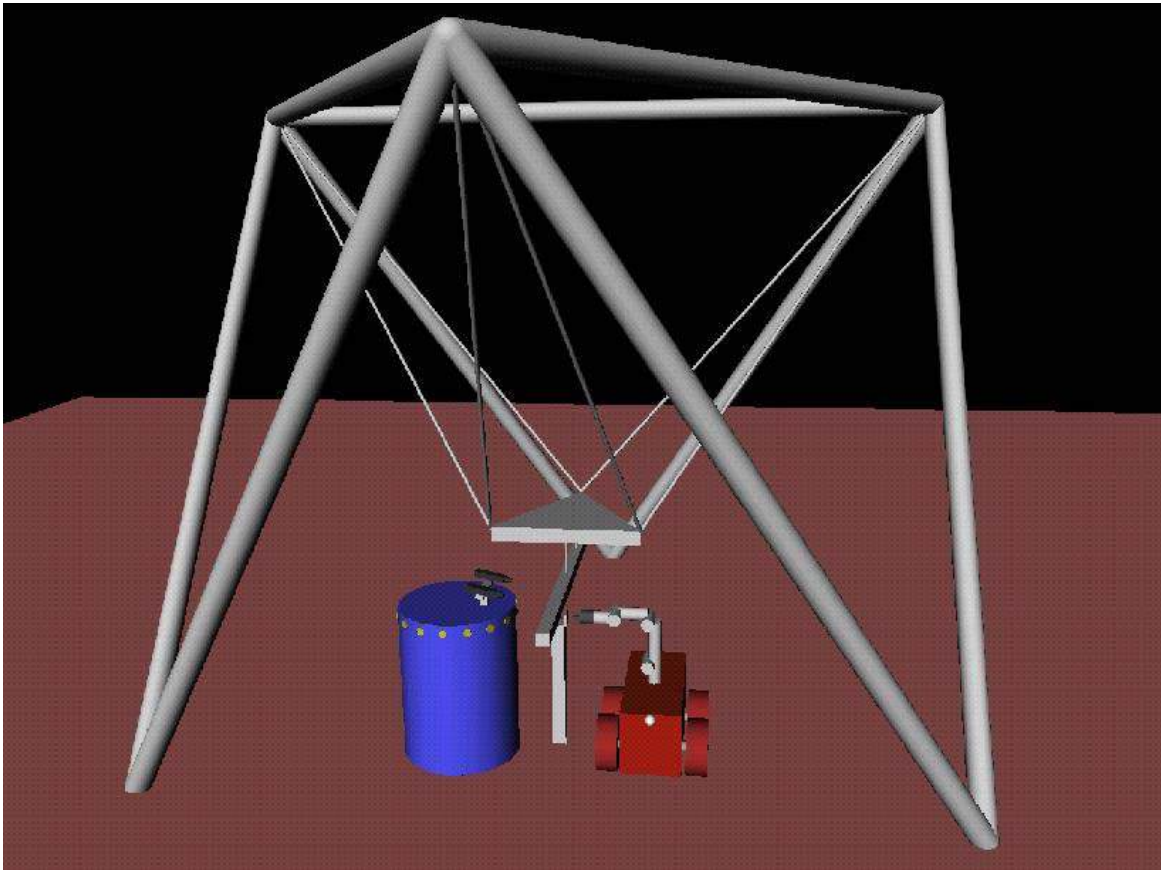

6-dof NIST RoboCrane

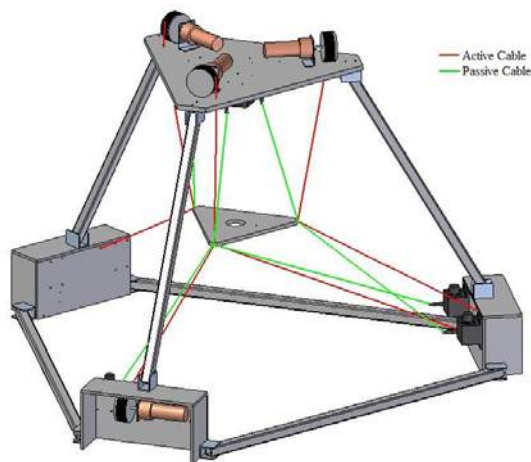

7-dof Cable-Suspended Robot

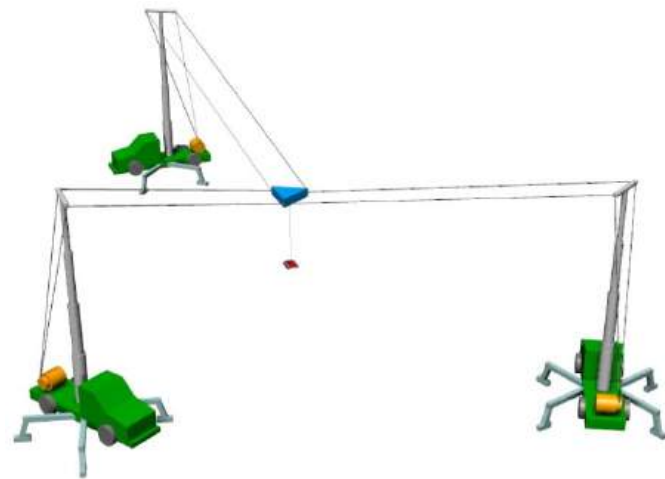

Deployable Search and Rescue Cable Robot

Soft Robots

Soft robots are constructed from highly compliant materials. Often they are developed from a high degree of biomimicry, such as for octopi and elephant trunks. Their absolute rigidity and accuracy are very low when compared to traditional rigid robots. However, their safety is inherently very good, including the ability to work among humans, and envelop objects for grasping them. Often they are actuated by air (or other fluid) pressure and/or artificial muscles, which are generally much more difficult to control than those of traditional robots.

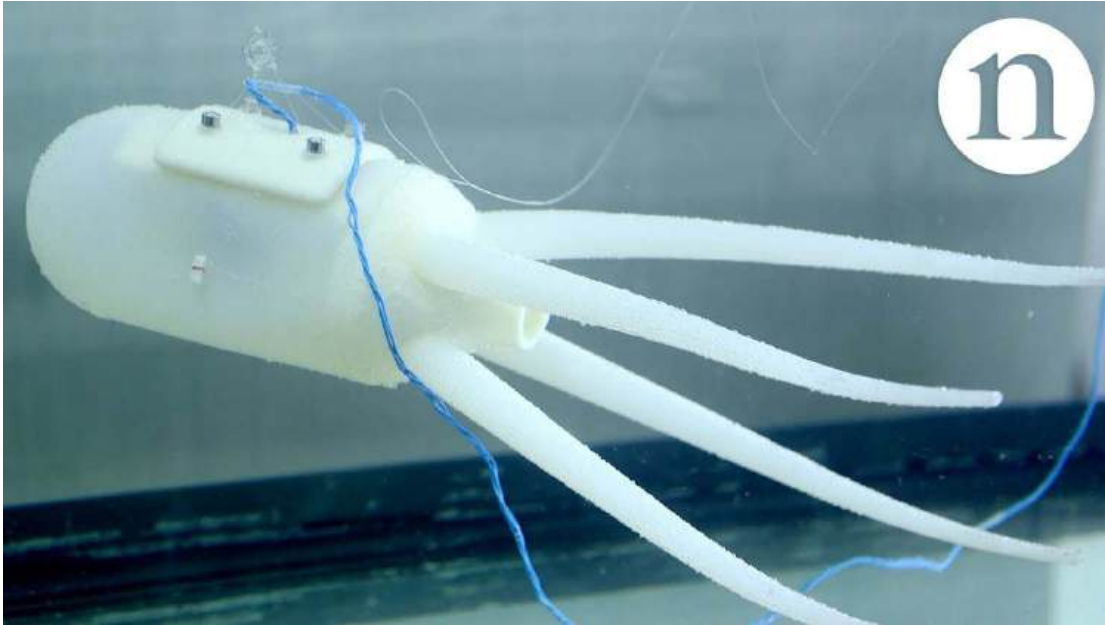

Octopus-Inspired Soft Robot (Quadrapus?)

<https://i.ytimg.com/vi/A7AFsk40NGE/maxresdefault.jpg>

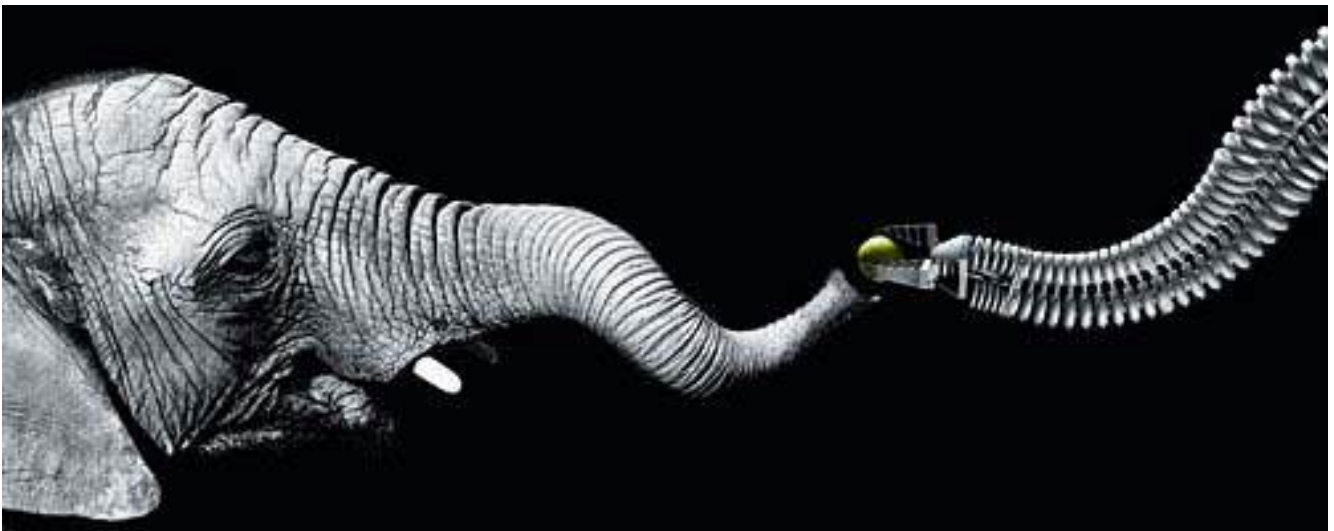

Elephant-Trunk-Inspired Soft Robot

<https://3c1703fe8d.site.internapcdn.net/newman/gfx/news/hires/roboticarmsh.jpg>

In a twist on history (where Hollywood often leads technology by decades), the soft robot Baymax in the film *Big Hero 6* was strongly inspired by work in the CMU Soft Robotics Lab.



Soft Robot Baymax from Big Hero 6

https://thetartan-assets.s3.amazonaws.com/uploads/35508/original/14252631454_341fb04d8c_o.jpg

The Venn diagram¹ below relates hard vs. soft, discrete vs. continuous, and non-redundant vs. redundant vs. hyper-redundant (kinematic redundancy) robots. Then the ensuing table¹ presents characteristics, properties, capabilities, and design of rigid vs. discrete hyper-redundant vs. hard continuous vs. soft robots.

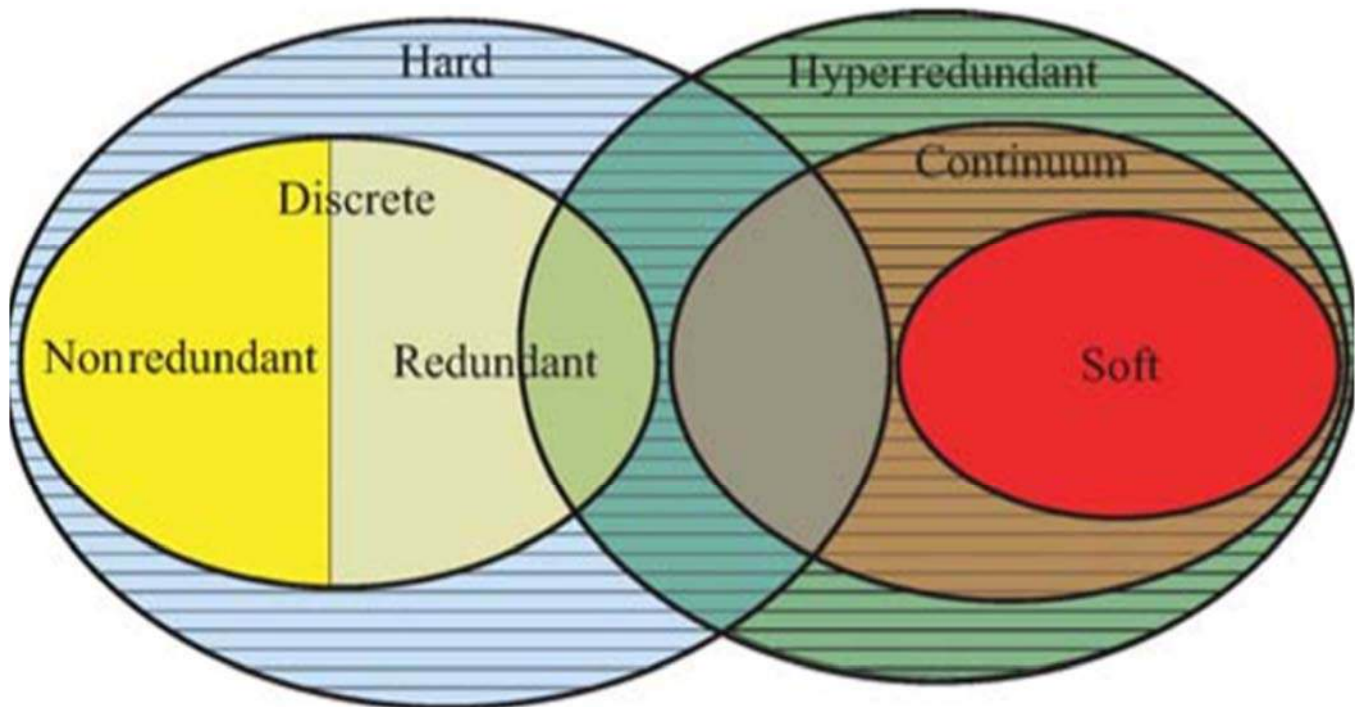

Hard vs. Soft Robots Venn Diagram

Trivedi et al., 2008

¹ D. Trivedi, C.D. Rahn, W.M. Kierb, and I.D. Walker, 2008, Soft robotics: Biological inspiration, state of the art, and future research, *Applied Bionics and Biomechanics*, 5(3): 99–117.

Hard vs. Soft Robots Characteristics

	Rigid	Discrete hyperredundant	Hard continuum	Soft
Properties				
df	Few	Large	Infinite	Infinite
Actuators	Few, discrete	Many, discrete	Continuous	Continuous
Material strain	None	None	Small	Large
Materials	Metals, plastics	Metals, plastics	Shape memory alloy	Rubber, electroactive
Capabilities				
Accuracy	Very high	High	High	Low
Load capacity	High	Lower	Lower	Lowest
Safety	Dangerous	Dangerous	Dangerous	Safe
Dexterity	Low	High	High	High
Working environment	Structured only	Structured and unstructured	Structured and unstructured	Structured and unstructured
Manipulable objects	Fixed sized	Variable size	Variable size	Variable size
Conformability to obstacles	None	Good	Fair	Highest
Design				
Controllability	Easy	Medium	Difficult	Difficult
Path planning	Easy	Harder	Difficult	Difficult
Position Sensing	Easy	Harder	Difficult	Difficult
Inspiration	Mammalian limbs	Snakes, fish		Muscular hydro

Trivedi et al., 2008

Robot Parts

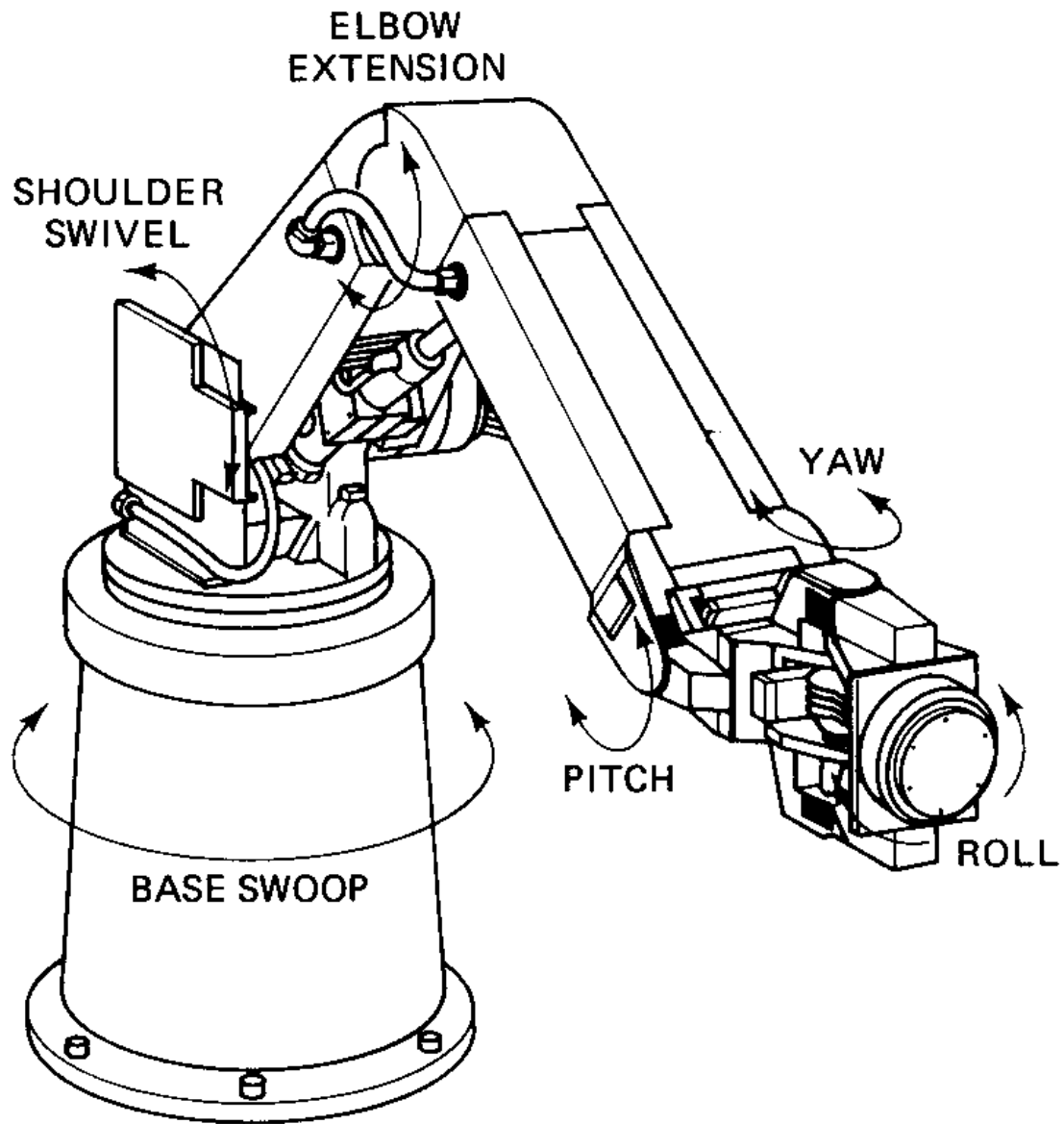

- base
- shoulder
- elbow
- wrist
- tool-plate
- end-effectors (not shown)

Technical Robotics Terms

Speed

Speed is the amount of distance per unit time at which the robot can move, usually specified in inches per second or meters per second. The speed is usually specified at a specific load or assuming that the robot is carrying a fixed weight. Actual speed may vary depending upon the weight carried by the robot.

Load Bearing Capacity

Load bearing capacity is the maximum weight-carrying capacity of the robot. Serial robots that carry large weights, but must still be precise, are heavy and expensive, with poor (low) payload-to-weight ratios.

Accuracy

Accuracy is the ability of a robot to go to the specified position without making a mistake. It is impossible to position a machine exactly. Accuracy is therefore defined as the ability of the robot to position itself to the desired location with the minimal error (usually 0.001 inch).

Repeatability

Repeatability is the ability of a robot to repeatedly position itself when asked to perform a task multiple times. Accuracy is an absolute concept, repeatability is relative. Note that a robot that is repeatable may not be very accurate. Likewise, an accurate robot may not be repeatable.

Precision

Precision is the 'fineness' with which a sensor can report a value. For example, a sensor that reads 2.1178 is more precise than a sensor that reads 2.1 for the same physical variable. Precision is related to significant figures. The number of significant figures is limited to the least precise number in a system of sensing or string of calculations.

Accuracy, Repeatability, and Precision Example

The concepts of **accuracy**, **repeatability**, and **precision** were defined on the previous page. These terms, all meaning quite different things, are very important in robotics. I find common English usage obscures these terms. For instance many people say **precise** when they mean **accurate**. Therefore a specific example may be warranted to further clear up these definitions.

This example came from real-world experience. Three days in a row I bicycled the exact same route to and from work and I was amazed that my bike computer recorded the following data.

day	distance (km)	time (hrs:min:sec)
day 1	15.06	0:45:17
day 2	15.06	0:45:19
day 3	15.06	0:45:18

Are these three rides **accurate**, **repeatable**, or **precise**?

Answer: this amazing data is highly **repeatable**, since the distance and time turned out nearly identical for three separate cycling instances of the same route.

Is this data **accurate**? To answer this, we need to know the true measure of distance. If we knew the exact distance to be 15.10 km, then we would say the data is quite accurate. Conversely if the true value were 16.22 km, we would say the data is not especially accurate and we would need to recalibrate the distance measurement of the computer. I cannot know the true distance without a lot of time and expense, so I am forced to rely on my previous calibration of the computer, using mile-marks on the bike path, for accuracy.

Usually the time measurement in a bike computer should be highly accurate, but with automatic starting and stopping of time measurement with bike motion, there could be some daily variations (that did not show up much in this data, evidently).

Is this data **precise**? The answer to this question is relative. The distance measurement of 15.06 is more precise than another computer that would measure 15.1 and less precise than yet another computer that would measure 15.063. The time measurement of 0:45.17 is more precise than another computer that would measure 0:45 and less precise than yet another computer that would measure 0:45:17.6.

Certainly the precision of my bike computer, to the nearest hundredth of a km and to the nearest second, is plenty precise for everyday cycling.

Work Envelope

Work envelope is the maximum robot reach, or volume within which a robot can operate. This is usually specified as a combination of the limits of each of the robot's parts. The figure below shows how a work-envelope of a robot is documented. This is also called **Robot Workspace**

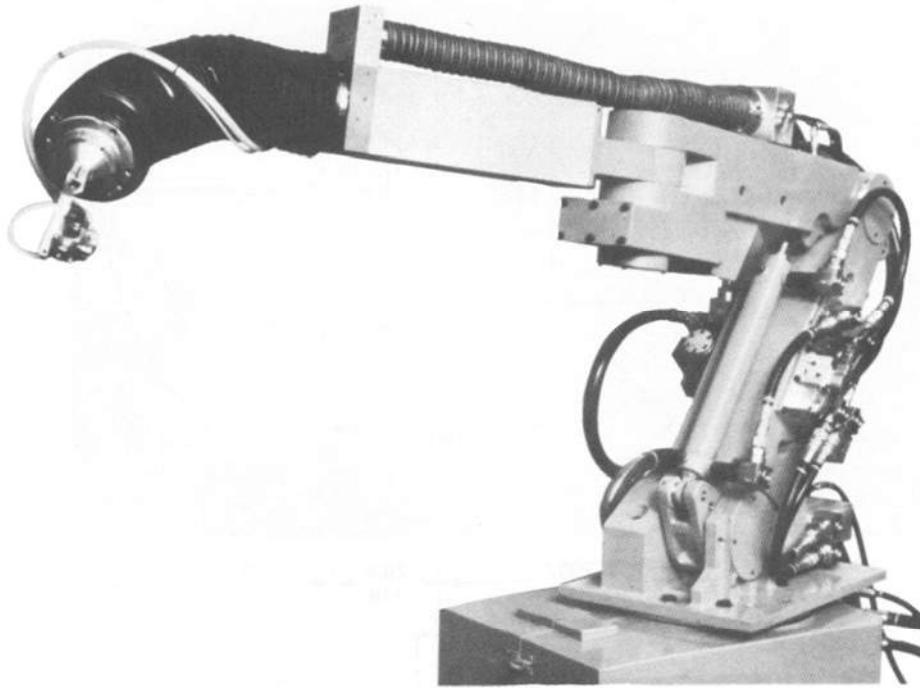
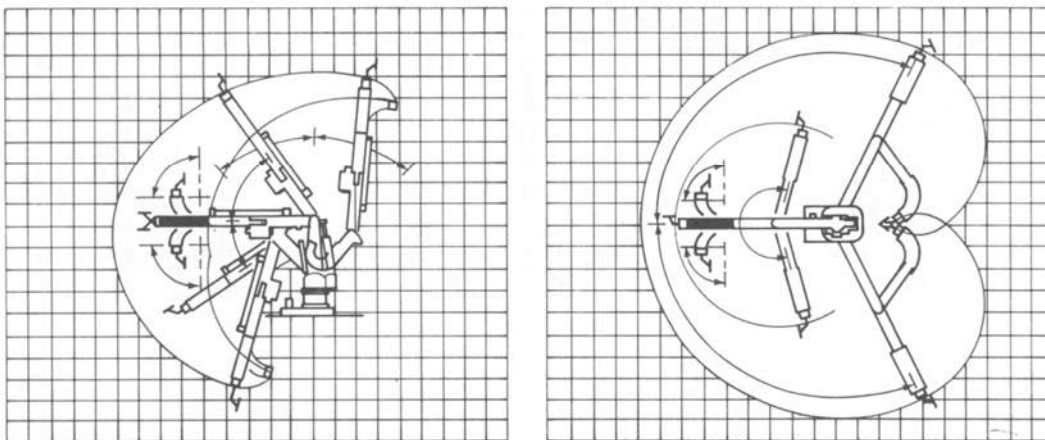

Photo used with permission of Cybotech Corporation.



1 SQUARE = 1 FOOT

Workcells

Robots seldom function in an isolated environment. In order to do useful work, robots must coordinate their movements with other machines and equipment, and possibly with humans. A group of machines/equipment positioned with a robot or robots to do useful work is termed a **workcell**. For example, a robot doing welding on an automotive assembly line must coordinate with a conveyor that is moving the car-frame and a laser-positioning / inspection robot that uses a laser beam to locate the position of the weld and then inspect the quality of the weld when it is complete.

Robot Power Sources/ Actuators

The robot drive system and power source determine characteristics such as speed, load-bearing capacity, accuracy, and repeatability as defined above.

Electric motors (DC servomotors)

A robot with an electrical drive uses electric motors to position the robot. These robots can be accurate, but are limited in their load-bearing capacity.

Hydraulic cylinders (fluid pressure)

A robot with a hydraulic drive system is designed to carry very heavy objects, but may not be very accurate.

Pneumatic cylinders (air pressure)

A pneumatically-driven robot is similar to one with a hydraulic drive system; it can carry less weight, but is more compliant (less rigid to disturbing forces).

McKibben Artificial Muscles (air pressure)

The McKibben artificial muscle was invented in the 1950s, but was too complicated to control until the 1990s (computers and nonlinear controls technology have greatly improved). Like the human muscle, these artificial muscles can only contract, and cannot push. They have natural compliance and a very high payload-to-weight ratio.



McKibben Muscle



Human Arm Model with McKibben Muscles

Piezoelectric materials

A piezoelectric material can be used as an actuator since it deflects when a voltage is applied. These are not very useful in robotics since the motion and forces are so small. Conversely, a piezoelectric material may be used as a sensor, reading the resulting voltage when the material is deflected by outside forces.

Robot End-Effectors

End-effectors are the tools attached to the end of the robot arm that enable it to do useful work. Most robot manufacturers either do not include end-effectors with their robots or include a general-purpose gripper to allow you to do simple tasks. Typically, the end-effectors must be purchased or designed separately. Also called **end-of-arm-tooling**, **end-effectors** are usually attached to the robot tool plate (after the last wrist joint) via a standard mechanical interface. Like robots themselves, end-effectors require a power source, often electric or pneumatic.

Grippers

Grippers are the most common end-effectors. They provide the equivalent of a thumb and an opposing finger, allowing the robot to grasp small parts and manipulate them.

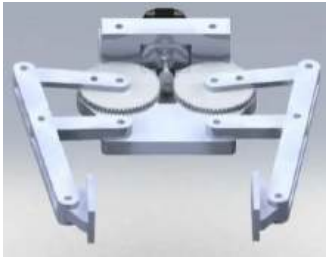

Parallel-Jaw Gripper

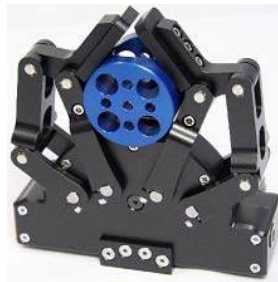

Versatile Planar Gripper



Suction-Cups Gripper

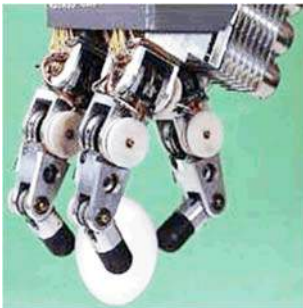

3-fingered Gripper

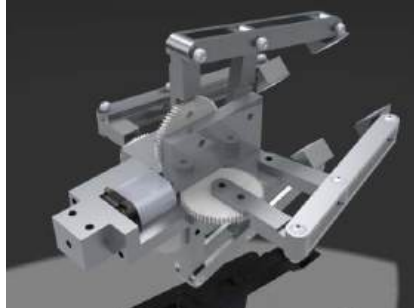

4-fingered Gripper



Humanoid Robot Hand



Fingerless Gripper

FROM CLAWS TO TENTACLES

The human hand isn't perfectly suited for every manual task. Many robotic hands are designed to perform specialized, often repetitive tasks—some taking their design inspiration from the animal world.

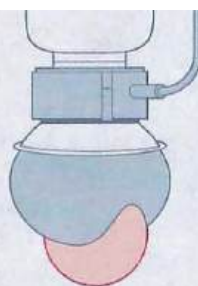

Vacuum gripper
The gripper, in its soft state, surrounds the object—then creates a vacuum to grasp it.

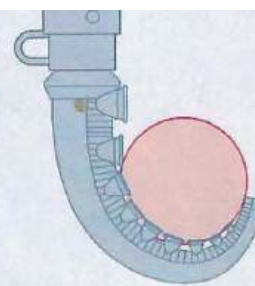

Gripping tentacle
The octopus-inspired gripper, with its rows of suction cups, wraps itself around an object.

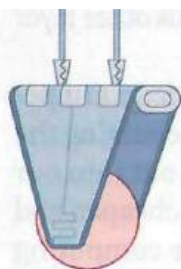

Flexible flaps
Soft, lightweight, and flexible flaps use electrostatic forces to pick up a fragile object.

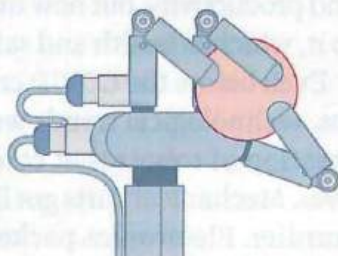

High-speed claw
This robot hand—fastest on the planet—can catch an object in five-hundredths of a second.

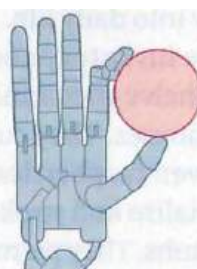

Humanoid hand
This robot has ultrasensitive touch sensors and moves much like a human hand does.



Biomimetic hand
It mimics the human hand with artificial joint capsules and rubber ligaments and tendons.

Types of Robot Grippers

National Geographic Magazine, September 2020

1. DETECT

A camera senses the target object and sends data to the software in the robot's "brain"—a desktop computer—which sends command signals to the hand.

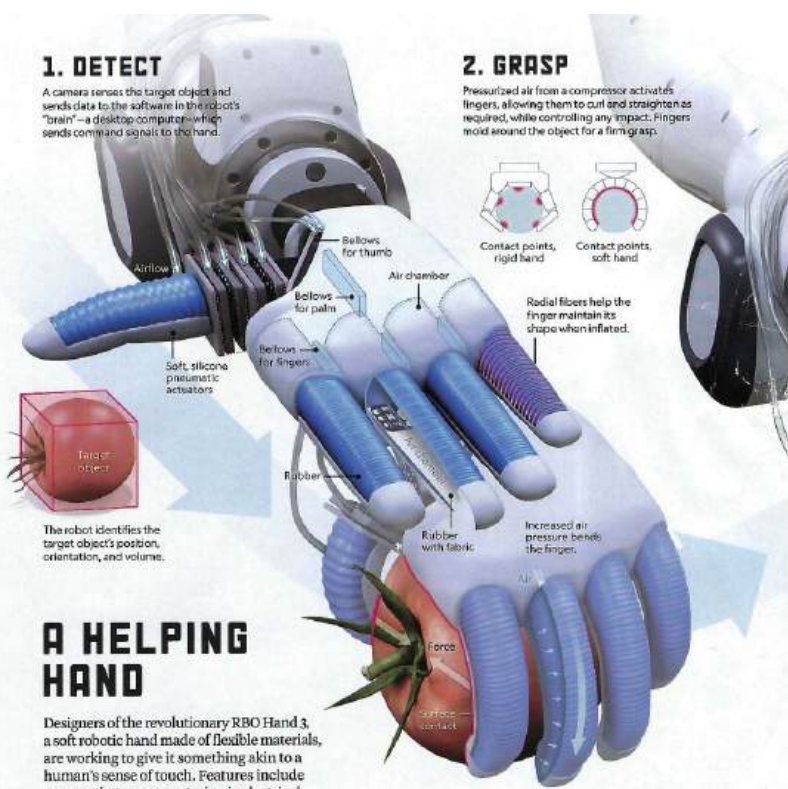

The robot identifies the target object's position, orientation, and volume.

A HELPING HAND

Designers of the revolutionary RBO Hand 3, a soft robotic hand made of flexible materials, are working to give it something akin to a human's sense of touch. Features include sensors that measure strain via electrical resistance and embedded acoustics to track where fingers are in contact with objects (or humans) and the amount of force.

2. GRASP

Pressurized air from a compressor activates fingers, allowing them to curl and straighten as required, while controlling any impact. Fingers mold around the object for a firm grasp.

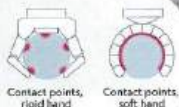

Radial fibers help the finger maintain its shape when inflated.

Increased air pressure bends the fingers.

3. MANIPULATE

A soft, compliant hand and opposable thumb allow the robot to change the position of the object to perform various tasks, such as getting a better grasp on it or passing it on.

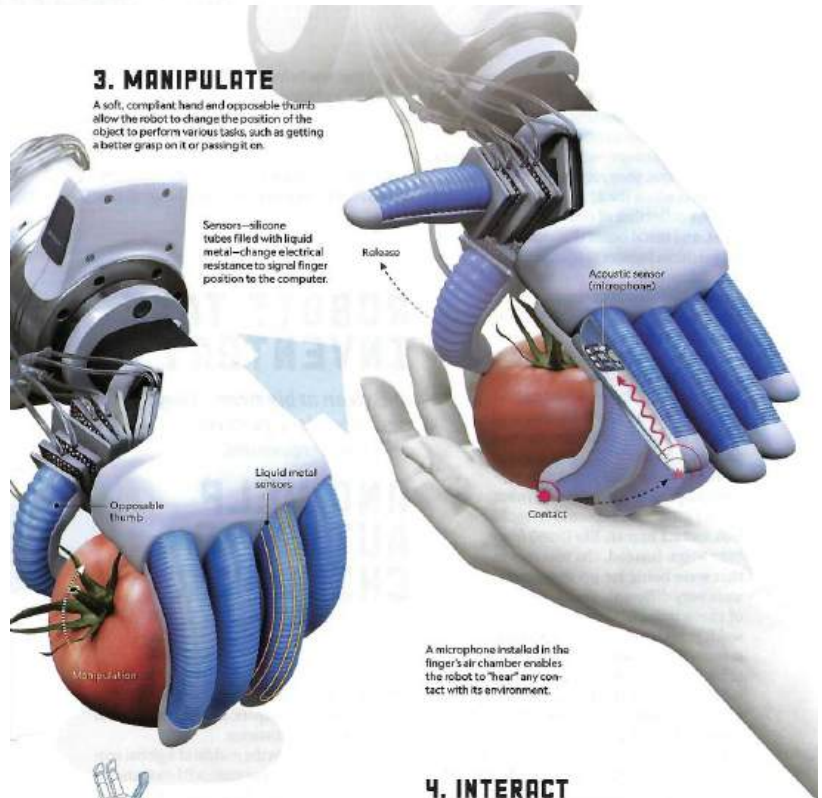

A microphone installed in the finger's air chamber enables the robot to "hear" any contact with its environment.



Opposable, humanlike thumbs can apply force in multiple directions for skillful manipulation.

4. INTERACT

Soft robots are safer than rigid, metal ones when it comes to working with humans. Any impact or force that could harm a human is reduced by the soft materials.

Robot Gripping Steps

National Geographic Magazine, September 2020

Machine Tools

Robot end-effectors can also be machine tools such as drills, grinding wheels, cutting wheels and sanders.



Drill Tool

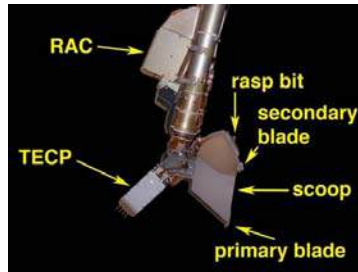

NASA Cutter/Scoop



Robot Measuring System

Measuring Instruments

Measuring instruments are end-effectors that allow the robot to precisely measure parts by running the arm lightly over the part using a measuring probe or gauge.

Laser and Water Jet Cutters

Laser and water jet cutters are robot end-effectors that use high-intensity laser beams or high-pressure abrasive water jets to cut sheet metal or fiberglass parts to shape.



Laser-beam Tool



Welding Torch



Spray-Painting Robots

Welding Torches

Welding torches are robot end-effectors that enable robots to weld parts together. These end-effectors are widely used in the automotive industry.

Spray Painting Tools

Automatic spray painting is a useful application for robots, in the automotive and other industries.

Glue Application Tools

Automatic spot or trajectory gluing is a useful application for robots, in the automotive and other industries.



Glue-Applying Robot



Robot Tool Changer

Tool Changers

Some robot systems are equipped with automatic tool changers to extend the usefulness of the robot to more tasks.

Robot Control Methods

All robot control methods involve a **computer, robot, and sensors**.

Lead-Through Programming

The human operator physically grabs the end-effector and shows the robot exactly what motions to make for a task, while the computer memorizes the motions (memorizing the joint positions, lengths and/or angles, to be played back during task execution).

Teach Programming

Move robot to required task positions via teach pendant; computer memorizes these configurations and plays them back in robot motion sequence. The teach pendant is a controller box that allows the human operator to position the robot by manipulating the buttons on the box. This type of control is adequate for simple, non-intelligent tasks.



Microbot with Teach Pendant

Off-Line Programming

Off-line programming is the use of computer software with realistic graphics to plan and program motions without the use of robot hardware (such as IGRIP).

Autonomous

Autonomous robots are controlled by computer, with sensor feedback, without human intervention. Computer control is required for intelligent robot control. In this type of control, the computer may send the robot pre-programmed positions and even manipulate the speed and direction of the robot as it moves, based on sensor feedback. The computer can also communicate with other devices to help guide the robot through its tasks.

Teleoperation

Teleoperation is human-directed motion, via a joystick. Special joysticks that allow the human operator to feel what the robot feels are called *haptic interfaces*.



Force-Reflecting Teleoperation System at Wright-Patterson AFB

Telerobotic

Telerobotic control is a combination of autonomous and teleoperation control of robot systems.

Robot Sensors

Robots under computer control interact with a variety of sensors, which are small electronic or electro-mechanical components that allow the robot to react to its environment. Some common sensors are described below.

Vision

A vision system has a computer-controlled camera that allows the robot to see its environment and adjust its motion accordingly. Used commonly in electronics assembly to place expensive circuit chips accurately through holes in the circuit boards. Note that the camera is actually under computer control and the computer sends the signals to the robot based upon what it sees.

Voice

Voice systems allow the control of the robots using voice commands. This is useful in training robots when the trainer has to manipulate other objects.

Tactile

Tactile sensors provide the robot with the ability to touch and feel. These sensors are used for measuring applications and interacting gently with the environment.

Force/Pressure

Force/pressure sensors provide the robot with a sense of the force being applied on the arm and the direction of the force. These sensors are used to help the robot auto-correct for misalignments, or to sense the distribution of loads on irregular geometry. Can also measure torques, or moments, which are forces acting through a distance. Can be used in conjunction with haptic interfaces to allow the human operator to feel what the robot is exerting on the environment during teleoperation tasks.

Proximity

Proximity sensors allow the robots to detect the presence of objects that are very close to the arm before the arm actually contacts the objects. These sensors are used to provide the robot with a method of collision avoidance.

Limit Switches

Limit switches may be installed at end-of-motion areas in the workspace to automatically stop the robot or reverse its direction when a move out-of-bounds is attempted; again, used to avoid collisions.

Other Sensors

- encoder measures angle
- potentiometer measures angle or length
- LVDT measures length (linear variable displacement transducer)
- strain gauge measures deflection
- ultrasonic sensor measures distance
- infrared sensor measures distance
- light sensor detects presence