



**NATIONAL OPEN UNIVERSITY OF NIGERIA**

**SCHOOL OF SCIENCE AND TECHNOLOGY**

**COURSE CODE: CHM 103**

**COURSE TITLE: INTRODUCTORY PHYSICAL CHEMISTRY I**

# CHM 103: Introductory Physical Chemistry 1

## COURSE DEVELOPMENT

<b>Course Developer</b>	Dr. Temi Busari UNIVERSITY OF LAGOS. AKOKA. LAGOS.
<b>Course Writer</b>	– Dr. Temi Busari UNIVERSITY OF LAGOS. AKOKA. LAGOS.
<b>Course Coordinator</b>	– A. Ikpe NATIONAL OPEN UNIVERSITY OF NIGERIA. LAGOS.
<b>Programme Leader</b>	Dr. F. Peters NATIONAL OPEN UNIVERSITY OF NIGERIA, LAGOS.

National Open University of Nigeria  
14/16 Ahmadu Bello Way.  
Victoria Island.  
Lagos.

Abuja Central Office  
245 Samuel Adesujo Ademulegun Street.  
Central Business District.  
Opposite Arewa Suites.  
Abuja.  
E-mail: [centralinfo@nou.edu.ng](mailto:centralinfo@nou.edu.ng)  
URL <http://www.nou.edu.ng>

©National Open University of Nigeria 2004

First Published 2004

ISBN 978-058-132-4

All Rights Reserved

*Published by University Press PLC for National Open University of Nigeria*

# Contents

<b>Course Guide</b>	<b>I</b>
<b>MODULE 1: INTRODUCTION</b>	<b>6</b>
Unit 1: Units and Dimensions	6
Unit 2: S\ Prefixes	13
Unit 3: Separation Techniques	20
<b>MODULE 2: GASEOUS STATE OF MATTER</b>	<b>27</b>
Unit 1: Gases	27
Unit 2: Ideal Gases	34
Unit 3: The Kinetic Theory of Gases	42
Unit 4: Real Gases	52
Unit 5: Liquefaction of Gases	63
<b>MODULE 3: SOLID AND LIQUID STATES OF MATTER</b>	<b>73</b>
Unit 1: Solid States and Solid Types	73
Unit 2: Nature of Bonds in Solids	81
Unit 3: Structures of Crystals	88
Unit 4: Liquids	94
Unit 5: Other Properties of Liquids	102
<b>MODULE 4: SOLUTIONS AND PHASE EQUILIBRIA</b>	<b>110</b>
Unit 1: Types of Solution	110
Unit 2: Solutions of Solids and Gases in Liquids	117
Unit 3: Binary Liquid Solutions- 1	123
Unit 4: Binary Liquid Solutions- 2	131
Unit 5: Partially Miscible Liquids	140
Unit 6: Some Colligative Properties	149
Unit 7: Phase Rule	157



## **Course Guide**

### **Table of Contents**

	Page
1.0 Introduction	2
2.0 What you will learn in this Course	3
3.0 Course Aims	3
4.0 Course Objectives	3
5.0 Working through the Course	4

## 1.0 Introduction

Chemistry deals broadly with the study of matter. There are different aspects of chemistry in which matter is studied. These are Physical, Inorganic, Organic and Analytical. In fact, the classification has been further broken down in such way that details of matter in terms of structure, periodicity and energy can be well understood. Physical Chemistry is thus one aspect. Physical Chemistry deals with a wide variety of topics from the states of matter to the reaction rates. The modern approach to chemistry is to deal with the following three aspects of matter.

- Structure
- Equilibrium Properties
- Ability to change

In physical chemistry, we deal with the remaining two aspects, namely, equilibrium properties and ability to change.

Physical Chemistry is one of the fundamental courses for Bachelor's Degree Programme in science (B.Sc.), and science education (B.Sc. Ed.) in any University in the whole world. This course will also be suitable as an elective for anyone who intends to study chemical engineering and other science-related professional programmes since it deals with the fundamental principles governing chemical transformations.

There are many physical chemistry courses you will encounter whilst studying for your degree. They are coded as CHM courses. This present course we are discussing its guide, is coded CHM 103. It is a two Credit unit course. There are four modules consisting of 20 units overall. The first module starts with a discussion on introduction. This is to give you an insight into the physical and mathematical instruments that you will be expected to equip yourself with for a better performance in chemistry in general and physical chemistry in particular.

The second module focuses on gaseous state of matter. The study of the properties of matter in solid, liquid and gas form is essential since the substances that take part in a chemical reaction are found in one of these three states of matter. Because of the copious nature of gas principle, it was found essential that a whole module be devoted to it.

The third module examines the solid and liquid states of matter. The structural comparisons, properties and nature of bonds in these two states of matter are explained.

In the fourth module, the concepts of solutions are discussed. Different solution types and especially the binary liquids are concentrated upon. Details of the units in each of the modules are provided in a table under section 5 of this guide.

The course though adapted from IGNOU course materials, has been greatly transformed and new concepts in physical chemistry added to suit students in Nigeria. You will be required to practice as much as possible on your own, the practical and self assessment questions termed as exercise provided in each of the modules. To assist you in accomplishing the course objectives, there will be some laboratory facilities in NOU for you to use and a tutor to facilitate your self instruction; you must also make tremendous effort to carry out most of the activities and questions raised in the modules. You are free to use other reading materials, suggested in each module, or an e-mail facility, telephone, and even the Internet to get more knowledge about the course.

The course guide provides you with additional information on what the course aims, objectives and learning procedures are for you to maximize the effective use of the four modules on Introductory Physical Chemistry I, CHM 103.

## 2.0 What you will learn in this Course

While we realize that the study of physical chemistry is quite vital and enormous, we will begin with the only introductory aspect of physical chemistry at this level. Specifically, in CHM 103, you will learn about system units, states of matter, nature of bonds, solutions and phase equilibria. The remaining aspects of physical chemistry like thermodynamics, thermochemistry, equilibrium and electrochemistry that we are unable to cover will be addressed in future courses. And in physical chemistry CHM 224 course, other advanced concepts of thermodynamics, photochemistry, electrochemistry, ionic equilibria, etc. will be addressed during the semesters of 200 level.

More importantly you will learn about the significance of units in solving problems in chemistry, appropriate usage and methods of handling apparatus and data, describing and comparing behaviours of different matter based on their structures and energy.

## 3.0 Course Aims

The aim of this course is to create an in-depth awareness and develop full understanding of the concept of energy as the capacity for change in any chemical reaction and moreover that strong relationship between energy and structure of matter is the foundation of physical chemistry.

Thus, the aim of this physical chemistry course is to:

1. Discuss the mathematical viabilities and standard procedure required in effective study of physical chemistry.
2. Explain the basic theories that govern various properties of matter.
3. Discuss some aspects of physical phase equilibria.
4. Build cases for the feasibilities of chemical reactions.
5. Demonstrate the various energy relationships in chemical reactions.
6. Give you an appreciation of system at equilibrium and factors affecting such systems.

## 4.0 Course Objectives

In order to achieve the course aims, there are some overall objectives set for the course. Moreover, each module and each unit has their respective objectives which you and your course tutor must constantly refer to, so that no objective is skipped or unachieved. It is therefore important that you outline what you have been able to achieve after completing a unit and compare the list with the unit objectives. This will help you to ascertain whether you have accomplished what is required of you.

All the module and unit objectives are specificities of the course objectives. The course objectives are stated as follows:

- Familiarize yourself with basic instruments for physical chemistry laboratory work:
- Write and apply correctly SI units
- Measure in and convert other units using SI units:
- Explain and compare the main features of solid, liquid and gas states:
- Appreciate the reasons why real gases deviate from gas laws:
- Analyse the properties of completely, partially miscible and immiscible liquids:
- Discuss the essence of types of solutions:
- Analyse phase changes in matter:
- Describe the conditions regulating the solubility of liquid solutions.



## 5.0 Working through this Course

This course contains some packages that you will be given at the beginning of the semester having satisfied the conditions of admission and registration. One of them is the course materials. The details of what constitute course materials will be discussed next. But let us remind ourselves that there are two areas expected of you to fulfil at the end of your studying this course. These are your full participation in both the continuous assessment and the final written examinations. Though there is a practical course developed for this level, it is advisable that some of the sections can be practicalised with the assistance of the course tutor. Your tutor will be readily accessible to issue out the exercise you are to do and submit according to specified rules and regulations from the authority. For you to be considered as successful in this course, you will be expected to pass at average level both the continuous assessment and the final written examinations. Thus, certain materials have been packaged for you that will enable you prepare adequately for both the continuous assessment and the final written examinations. First and foremost is the study unit materials that consists of 20 units in all. However, the units have been packaged for you in modules as shown below.

### Study Units

Number of Module	Module	Unit	Title
1	Introduction	1 2 3	Units and Dimensions SI Prefixes Separation Techniques
2.	Gaseous State of Matter	1 2 4 5	Gases Ideal Gas The Kinetic Theory of Gases Real Gases Liquefaction of Gases
3.	Solid and Liquid States of Matter	1 2 3 4 5	Solid States and Solid Types Nature of Bonds in Solids Structure of Crystals Liquids Other Properties of Liquids
4	Solutions and Phase equilibria	1 2 3 4 5 6 7	Types of Solutions Solution of Solid and Gases in Liquid Binary Liquid Solutions1 Binary Liquid Solutions2 Partially Miscible Liquids Some Colligative Properties Phase Rule

By and large, you should be able to complete this two-Credit unit for about 15-17 weeks in a Semester. Well spread out in each of the unit are introduction to the unit, specific objectives, reading material on sub-topics, self-assessment questions (SAQs), some exercises, conclusion, summary, tutor-marked assignments (TMA) and references.

### Course materials

Major course materials of the course are as follows:

1. **Course Guide:** This looks like a blueprint that spells out what constitutes the course itself. It also extends to the basic information you require on how best to study this introductory physical chemistry.
2. **Study Units:** Each of these provides an overview of the content and number of units that will be covered in this course. The contents are spelt out in seven major headings: the introduction, objectives to guide what to focus on, the content, conclusion, summary of the content, references and other materials that will facilitate your understanding and the tutor-marked assignments. In the body of content are exercises that should always attract your attention after every reading.
3. **Assignment files:** These files contain challenging tutorial questions termed as Tutor-Marked Assignments (TMAs) that will enable you to assess yourself at the end of every assignment that will be handed out by your tutor. Since we are operating a course unit system, your scores in these assignments will be stored, the cumulative of which shall be used to compute your cumulative grade score in this course.
4. **Presentation schedule:** Certainly, the modus operandi (e.g. time table, hours expected on each unit/module, assignment submission procedure) on how it will be self-tutored with the best monitoring techniques by the National Open University of Nigeria will be in the information package of this schedule.

### Study Units

Details of the study units have earlier been presented. It is spelt out in modules with corresponding units and titles. You will be expected to spend 2-3 hours in studying a unit. The exercise items are provided to enable you test your ability in whatever you have covered and to help you monitor the progress made per sub-topic in the unit. There is also the TMA packaged for you but will be given as assignments.

### References and other resources

Apart from this study unit, some reference materials are provided as additional reading materials to support your study. It is not the responsibility of NOU to provide them but you may be lucky to spot them in the library instituted by NOU.

### Instructional media

As an open and distance Learning University, several and relevant multimedia that can make learning easy are available. Accessibility to other instructional media will be disclosed to you from time to time.

### Assignment file

This has been discussed earlier. It is mandatory to always turn in your assignments to any tutor assigned.

### Assessment

You will be expected to complete at least ten assignments by the end of the course. Some of these will be in form of a project, continuous assessment (CA) written tests. Each of these ten assignments shall carry ten marks making 100% for continuous assessments. You will also be expected to write a final examination in the course. The overall score in the course will be a sum of 40% of CA and 60% of written examination. You will be expected to have 50% in the CA and 50% in the written examination, anything short of this will count as a failure.

# MODULE 1: INTRODUCTION

## Unit I: Units and Dimensions

### Table of Contents

	<b>Page</b>
1.0 Introduction	7
2.0 Objectives	7
3.0 Units of Physical Quantities	7
3.1 Concept of SI	7
3.2 Basic Units	7
3.3 Derived Units	9
4.0 Conclusion	12
5.0 Summary	12
6.0 References and Other Resources	12
7.0 Tutor-Marked Assignment	12

## 1.0 Introduction

In your previous course of studying science in general and chemistry in particular, you would have realized that you are often engaged in problems solving. Specifically in physical chemistry, equations containing physical quantities are eminent in problem solving. For you to be at ease with these mathematical expressions and applications, you will need to understand how to represent one single physical quantity in terms of its magnitude and units.

In this Unit, we shall examine how *Systeme International* (SI) came about. We will study the principles of representing the units of the physical quantities. In this unit also, we shall state the SI units for a few basic and derived quantities.

## 2.0 Objectives

By the end of this Unit, you should be able to:

- Explain the need for SI units
- State basic and derived SI units
- Define the basic and derived units
- Derive the dimension and the SI unit of a physical quantity using an appropriate equation

## 3.0 Units of Physical Quantities

### 3.1 Concept of SI

Till recently in the scientific world, mainly two systems of units have been in common use. One is the metric system, that is, c.g.s (centimetre, gram and second) which was more commonly used over the European continent and the other is f.p.s (foot, pound and second) prevalent in England. A common system of units helps in exchanging the scientific facts and ideas originating from different countries. It is better still if the system of units could be derived from the scientific formulae or fundamental constants. This long felt need for a common system of scientific units was realized at a meeting called *General Conference on Weight and Measures in 1960*. At this meeting, the international scientific community agreed to adopt common units of measurement known as International System of Units. This is abbreviated as SI units from the French name, *Systeme International*.

### 3.2 Basic Units

There are seven basic physical quantities from which all other physical quantities can be derived. Can you mention two of those basic physical units you are familiar with? You are right if length, time, mass, temperature are parts of what you stated in your answer. Each of these physical quantities has a unit termed basic unit, with a specified symbol. Table 1.1 presents in details the names of these physical quantities along with their symbols of SI units. Each of these quantities is regarded as having its own *dimension*. The dimensions of basic quantities are useful in defining the derived physical quantities, which we would use in Sec 3.2. We will be using the symbol given in column (II) of Table 1.1 to refer to the dimensions of the basic quantities.

**Table 1.1: Basic Physical Quantities and their Units**

Physical quantity	Symbol of the quantity	Name of SI unit	Symbol of SI unit
Length	<b>l</b>	<b>metre</b>	m
Mass	<i>m</i>	kilogram	kg
Time	<i>t</i>	second	s
Electric current	<i>I</i>	ampere	A
Temperature	<i>T</i>	Kelvin	K
Luminous Intensity	<b>I</b>	candela	cd
Amount of Substances	<i>n</i>	mole	mol

*Note that  $m$  (italized) is the symbol for mass and  $l$  (roman) is the symbol of SI unit for metre.*

Before you proceed, have you ever thought of what these basic quantities are? Assuming you can not remember what length, mass, time, temperature, electric current, luminous intensity and amount of substance, their definitions are briefly stated here.

Recall that length is a measure of distance or duration of time. Let us consider temperature as a measurement of the hotness or coldness of matter. Have you ever thought of the relationship between temperature and heat? What is heat and what is temperature? What relationship exists between the two? To help you, from what we saw temperature is, it means it is a property of matter whereas, heat is an energy flow to and from matter. When heat is added to matter or removed, there will be an increase or decrease in temperature. The quantity of heat added to a matter determines its temperature. In Table 1.1, the unit of temperature is Kelvin and not Celsius or Fahrenheit. Why is Kelvin used for temperature and how is it obtained?

**However, we are not going to define kilogram, meter, etc. since our aim is to use these units and not to establish the basis of these units. Have you ever thought of how these units are used in daily life experience? For instance, a meter man comes home to read your meter, what does he read, the electric current or the quantity of electricity that will be used to calculate your bill? If your answer is electric current, why do you think you are correct? It is important you clarify your answers from the National Electric Power Authority (NEPA) office.**

These questions are raised to enable you prepare for our subsequent discussion.

### **Exercise 1**

- What was the name of the German Scientist that devised earliest temperature scales" .....
- Recall from your previous school chemistry, the mathematician and physicist who invented the Absolute scale and what does Kelvin stand for"

### 3.3 Derived Units

Apart from the basic physical quantities there are others called derived physical quantities. As the name implies, they are derived from the seven basic quantities shown in Table 1.1. The derivations are done by definitions involving multiplication, division, differentiation and integration.

In Table 1.2 and Table 1.3 the derived SI units without and with special names are given. You will find it useful throughout your study of chemistry to refer to these tables whenever some physical quantities are to be expressed. Since electrochemistry will be studied in this course, a few useful electrical quantities are also included in Table 1.3

Table 1.2 Derived SI Units Without Special Names

Physical Quantity	Definition	Dimensional Formula	Name of the SI unit	Symbol of the SI unit
Area*	Length x length	$l^2$	square metre	$m^2$
Volume*	Length x length x length	$l^3$	cubic metre	$m^3$
Density	Mass/ Volume	$ml^{-3}$	kilogram per cubic metre	$kg\ m^{-3}$
Velocity	Displacement/Time	$lt^{-1}$	metre per second	$ms^{-1}$
Acceleration	Change in Velocity/ time	$lt^{-2}$	metre per second squared	$ms^{-2}$
Molar mass	Mass/ amount of the substance	$nu\ l^{-1}$	kilogram per mole	$kg\ mol^{-1}$

\*The definitions given for area and volume are of general type, although specific formulae are to be used depending on the geometry of a surface or an object.

Let us examine how the SI units of acceleration are worked out from its dimensions. Go back to Tables 1.1 and 1.2.

In Table 1.2, column (iii) the dimensions of acceleration is  $lt^{-2}$ . What is the corresponding unit of acceleration?"

You are correct if you state that units of acceleration  $ms^{-2}$  (see columns(ii) and (iv) of Tables 1.1)

Let us see how the definitions and the units of physical quantities can be obtained using Tables 1.1 – 1.3

Table 1.3: Derived SI Units Having Special Names

Physical Quantity	Definition	Dimensional Formula	Name of the SI unit	Symbol of the SI unit
Force	Mass x acceleration	$MLT^{-2}$	newton	$N$ or $kg\ m\ s^{-2}$
Pressure	$\frac{\text{Force}}{\text{Area}}$	$M L^{-1} T^{-2}$	pascal	Pa or $N\ m^{-2}$ or $kg\ m^{-1}\ s^{-2}$
Energy or Work	Force x Distance	$M L^2 T^{-2}$	JOULE	J or $N\ m$ or $P\ J\ m^{-1}$
Electric charge	Electric current x Time	$IT$	coulomb	$C$ or $A\ s$
Electric potential difference	$\frac{\text{Electric Energy}}{\text{Electric charge}}$	$\frac{ML^2T^{-2}}{IT} = M^2L^2T^{-3}I^{-1}$	volt	V or $J\ C^{-1}$ or $kg\ m^2\ A^{-1}\ s^{-3}$
Electric resistance	$\frac{\text{Electric Potential diff}}{\text{Electric current}}$	$\frac{ML^2T^{-3}I^{-1}}{IT} = M^2L^2T^{-3}I^{-2}$	ohm	$\Omega$ or $V\ A^{-1}$
Electric conductance	$\frac{1}{\text{Electric resistance}}$	$\frac{1}{M^2L^2T^{-3}I^{-2}} = M^{-2}L^{-2}T^3I^2$	siemens	$S$ or $A\ V^{-1}$ or $A^2\ s^3\ kg^{-2}\ m^{-2}$
Frequency	$\frac{\text{(Number of "m-es or cycles)}}{\text{Time}}$	$T^{-1}$	hertz	Hz or $s^{-1}$

Deductions of the SI unit physical quantity (Tables 1.1-1.3)

Now, I want you to use the dimensions of these quantities to derive the dimension and the unit of R,

What do you have in your substitution?

Your answer should look thus:

The mathematical relationship to be used for the ideal gas equation is as shown below\_ (We shall study more of this in Unit 2\_)

$$P \times V = n R T \quad (3_1)$$

Rearranging this,

$$R = \frac{P \times V}{n T} \quad (3_2)$$

The dimensions of the quantities in the right hand side of Eq\_ 3\_1 are mentioned in Tables 1.1-1.3\_ We use the dimensions of these quantities to derive the dimension and the unit of R as shown below

$$\begin{aligned} \text{Dimensions of } R &= \text{Dimensions of } \left[ \frac{P \times V}{n T} \right] \\ &= \frac{[M L^{-1} T^{-2}] [L^3]}{[M] [T]} \\ &= \frac{M L^2 T^{-2}}{M T} = (M^0 L^2 T^{-3}) \end{aligned}$$

Hence, the units of R = joule mole<sup>-1</sup> Kelvin<sup>-1</sup>

(using the units corresponding to the dimensions mentioned in Tables 1.1-1.3)

Thus, R has the dimensions of (energy) (amount of substance)<sup>-1</sup> (temperature)<sup>-1</sup> and the unit J mol<sup>-1</sup> K<sup>-1</sup>

In general the following hints would be useful in the deduction of the unit of a quantity (which we name as test quantity):

- (i) Write an equation relating the test quantity to other quantities of known dimensions.
- (ii) Rearrange this equation such that only the test quantity is on the left hand side and others are on the right hand side.
- (iii) Substitute the dimensions of the quantities on the right hand side and simplify.
- (iv) Write down the units corresponding to the simplified dimensions, using Tables 1.1- 1.3.

Use the above hints and work out the following Exercises.

#### Exercise 2

Derive the dimension and the unit of root mean square speed ( $U_{rms}$ ) of a gas using the following equation:

$$U_{rms} = \sqrt{\frac{3 \times \text{gas constant} \times T}{\text{Molar mass}}}$$

The dimension of molar mass is  $mol^{-1}$

#### Exercise 3

From the equation, kinetic energy =  $\frac{1}{2} \times \text{mass} \times (\text{velocity})^2$ . derive the unit of kinetic energy.



#### 4.0 Conclusion

In the study of physical chemistry, there are many physical quantities both basic and derived you will be coming across. In this Unit we have been able to state all and define some of the basic units. From the basic units, derived units are obtained. Using the units in the tables provided, we were also able to do some deductions. The SI units must be consistently used in applications on quantities.

#### 5.0 Summary

In this Unit you have learned that:

- There are seven basic physical quantities namely length, mass, time, electric current, temperature, luminous intensity and amount of substance.
- Length is a measure of distance or duration of time and temperature is a measure of how hot or cold a matter is but its measurement is a function of heat energy flow
- Other physical quantities with their corresponding SI units can be derived or deduced.
- The gas constant, R, has dimensions of (energy) (amount of substance)<sup>-1</sup> (temperature)<sup>1</sup>

#### 6.0 References and Other Resources

IGNOU (1997). States of Matter: Physical Chemistry CHE-04 New Delhi.

#### 7.0 Tutor-Marked Assignment

1. Examine the following statements and indicate their validity by writing T for True and F for False. If false, indicate the reason for your answer:
  - (i) The SI unit of mass is gram
  - (ii) The symbol of SI unit of temperature is k
  - (iii) The SI unit of pressure is pascal
  - (iv)  $1 \text{ N} = 1 \text{ kg m s}^{-2}$
  - (v)  $1 \text{ O} = 1 \text{ g}$
2. If 25.3g of a substance occupies a volume of 23cm<sup>3</sup> calculate its density in SI units.
3. The molar mass (M<sub>m</sub>) of an ideal gas is related to its pressure (p), density (ρ) and temperature (T) according to the equation.

$$M_m = \frac{p}{\rho T}$$

In this expression, R is the gas constant. Find the SI unit of molar mass.

## Unit 2: SI Prefixes

### Table of Contents

	Page
1.0 Introduction	14
2.0 Objectives	14
3.1 SI Prefixes	14
3.2 Grammatical Rules for Representing the SI units	15
3.3. Conversion of Non-SI units to SI units	16
3.3.1 Construction of a Unit Factor	17
3.3.2 Conversion into SI unit	17
4.0 Conclusion	IR
5.0 Summary	IS
6.0 References and Other Resources	19
7.0 Tutor-Marked Assignment	

## 1.0 Introduction

In Unit 1 of this Module, we discussed the history of SI units and explained the basic and derived units. In this Unit, we shall explain the prefixes used to change the order of magnitude of the SI units. Also we shall state the rules for representing the SI units and the procedure of converting non-SI units into SI units.

## 2.0 Objectives

By the end of this Unit, you should be able to:

- Explain how the multiples and the sub-multiples of SI units can be obtained.
- Describe the rules for writing SI units and
- Convert non-SI units into SI units.
- Use the rules accordingly when solving problems.

## 3.1 SI Prefixes

We now discuss how to overcome the difficulty of expressing the units of physical quantities which are either very large or small, as compared to the SI units. We add a prefix to the unit such that the magnitude of the physical quantity is  $10^{-12}$  m. We express it conveniently as 74 pm where pico is the SI prefix and p is its symbol. The list of SI prefixes is given in Table 2.1 and it is possible to change the order of magnitude of any unit using this table.

Table 2.1: SI Prefixes

Sub-multiple	Prefix	Symbol	Multiple	Prefix	Symbol
$10^{-1}$	deci	d	10	deca	da
$10^{-2}$	centi	c	$10^2$	hecto	h
$10^{-3}$	mili	m	$10^3$	kilo	k
$10^{-6}$	micro	$\mu$	$10^6$	mega	M
$10^{-9}$	nano	n	$10^9$	giga	G
$10^{-12}$	pico	p	$10^{12}$	tera	T
$10^{-15}$	femto	f	$10^{15}$	peta	P
$10^{-18}$	atto	a	$10^{18}$	exa	E

More examples for usage of prefixes are given below:

$10^3$  m = 1 km;  $10^{-9}$  s = 1 ns

The unit for mass is kg which is already prefixed. We do not add a second prefix but rather use a single prefix on the unit gram. Thus to represent  $10^{-9}$  gram, the symbol used is ng and not pkg. For  $10^9$  gram, megagram is used and not pkg.

### Exercise 1

Write down the following proper SI unit symbols and prefixes:

- (a) 10<sup>3</sup> metre                      (b) 10<sup>-6</sup> second                      (c) 10<sup>3</sup> pascal

## Exercise 2

Suggest a convenient SI unit to specify the diameters of atoms and molecules, which are in the region of  $10^{-10}$  m.

.....

### 3.2 Grammatical Rules for Representing the SI units

The following rules will be of help to you while using the SI units:

- (i) The symbol of a unit is never to be used in plural form. Writing 10 kilogram as 10 kg is correct and not as 10 kgs.
- (ii) In normal usage, full stop is used to indicate the end of a sentence or the presence of an abbreviation. To denote SI unit as an abbreviation by means of a full stop after the symbol is incorrect; but if the SI unit is at the end of a sentence, then full stop can be used.
- (iii) When there is a combination of units, there should be space between the symbols. If the units are written without leaving space, the first letter is taken as a prefix. Thus m/s represents metre per second whereas ms stands for milli second.
- (iv) Always leave a space between the magnitude and the unit symbol of a physical quantity. For example, writing 0.51 kg is correct but not 0.51kg.
- (v) Symbol of the unit derived from a proper name is represented using capital letters but not the name of the unit (Table 1.3 in Unit I) for example, writing 100 newton or 100 N is correct but not 100 Newton or 100 n.
- (vi) For numbers less than unity, zero must be inserted to the left of the decimal point. Thus writing 0.23 kg is correct but not .23 kg.
- (vii) For larger numbers exceeding five figures, one space above every three digits (counting from the right end) must be left blank. Commas should not be used to space digits in numbers. For example 15 743 231 N is correct but not 15,743,231 N. It is preferable to use proper SI prefixes.
- (viii) The degree sign is to be omitted before K while representing temperature. For example 298 K is correct but not 298° K.
- (ix) You should not mix words and symbols for representing SI units for example, for it is proper to write N m<sup>2</sup> or Newton per square metre and not N per square metre.
- (x) Exponents (or powers) operate on prefixes also. Let also derive the relationship between cm<sup>3</sup> and m<sup>3</sup> using the relation. 1 cm<sup>3</sup> = 10<sup>-6</sup> m<sup>3</sup>.
- (xi) To show that the particular unit symbol has a negative component, one may be tempted to use the sign "/" as solidus. It is better to avoid the usage of this sign and if used no more than one should be employed. For example, representing pascal (kg m<sup>-1</sup> s<sup>-2</sup>) as kg/m s<sup>2</sup> is allowed but not kg/m/s.

So far, we studied some rules for writing SI units. Let us now discuss the dimensions for some mathematical functions, which are useful in studying this course

While representing the relationship among the physical quantities of substances, we often come across the mathematical functions like  $\sin \theta$ ,  $\cos \theta$  and  $\ln x$ . It is to be kept in mind that trigonometric ( $\sin \theta$ ,  $\cos \theta$  etc) exponential ( $e^{\theta}$ ) and logarithmic functions ( $\ln x$  or  $\log x$ ) are dimensionless quantities and hence have no units.

You can understand the validity of this statement, once you recapitulate the definitions of these functions. We shall illustrate this for the functions,  $\sin \theta$  and  $e^x$ .

From the right-angle triangle PQQ.

$$\sin \theta = \frac{\text{length of FQ}}{\text{length of OP}}$$

Evidently  $\sin \theta$  is dimensionless and has no unit. The same is true of other trigonometric functions also.

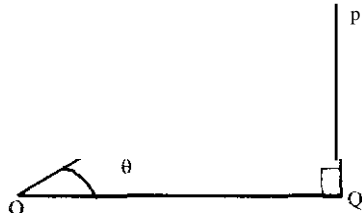

As an illustration for the exponential series, let us expand  $e^x$ .

$$e^x = 1 + x + \frac{x^2}{2!} + \frac{x^3}{3!} + \frac{x^4}{4!} + \dots$$

+

Since addition or subtraction must be done between quantities of the same dimensions, etc.  $e$  and  $x$  in the above series must all be of the same dimensions. This indicates that  $x$  and  $e^x$  are dimensionless and unitless. Again this is true of  $e^x$  and  $\ln x$  or  $\log x$  also.

### Exercise 3

In Module 2, Unit 2 of this book, you will study that Bragg equation,

$$n\lambda = 2d \sin \theta$$

is useful in the diffraction studies of X-rays by crystals. Given that  $n$  is dimensionless and  $\lambda$  has the dimension of length, find the dimension and unit of  $d$ .

## Conversion of Non-SI units to SI units

Often in textbooks we see that the quantities are expressed in non-SI units such as c.g.s and f.p.s. In such a situation, we must know how to convert non-SI units into SI units. There is a simple procedure available for this purpose. It is called the *factor method*. This method can be explained using the following example.

### Example

An important practical unit of pressure is atmosphere (atm). To be exact at 293.2 K a column of mercury, 76 cm high ( $h = 76 \text{ cm}$ ) exerts a pressure of 1 atm. (Table 2.2).

The SI equivalent of 1 atm pressure can be obtained by substituting the value of  $h$ ,  $g$  (acceleration due to gravity) and  $\rho$  (density of mercury) in the SI units in the formula:

$$P = h\rho g \tag{3.1}$$

The values of  $g$  and  $\rho$  in c.g.s units are  $980.66 \text{ em} \cdot \text{s}^{-2}$  and  $13.595 \text{ gem}^{-3}$  respectively. We have to convert the values of  $h$ ,  $g$ , and  $\rho$  into SI units, before substituting them in equation 3.1. To accomplish this we must know how to construct a unit factor.

### 3.3.1 Construction of a Unit Factor

A unit factor is a ratio that is equal to 1. It states the relationship between the SI and the non-SI units of a physical quantity. It is constructed from the equivalent statement relating both these units. For example, for the conversion of the unit of  $h$  from c.g.s into SI units, the equivalence statement is

$$100 \text{ cm} = 1 \text{ m}$$

From this equivalent statement, the unit factor for conversion can be constructed by dividing both sides by 100 cm (i.e. equivalent value in non-SI unit).

$$\frac{100 \text{ cm}}{100 \text{ cm}} = \frac{1 \text{ m}}{100 \text{ cm}} \quad \dots\dots 3.2$$

In general, the unit factor for conversion of a physical quantity into SI is given by the relationship:

$$\text{Unit factor} = \frac{\text{SI unit of a physical quantity}}{\text{Equivalent amount of the physical quantity in non-SI unit}}$$

Let us now see how the unit factor is useful in unit conversion.

### 3.3.2 Conversion into SI unit

The unit factor is to be multiplied by the actual value of the physical quantity in non-SI unit to get the quantity in SI units. For example, the value of  $h$  (actual value = 76 cm) is to be multiplied by the unit factor,  $\frac{1 \text{ m}}{100 \text{ cm}}$  to get it in metre unit.

$$h \text{ in SI unit} = 76 \text{ cm} \times \frac{1 \text{ m}}{100 \text{ cm}} = 0.76 \text{ m}$$

The conversion of units of  $h$ ,  $g$  and  $\rho$  into SI units is represented in Table 2.2

Table 2.2: Conversion of Units of  $h$ ,  $g$  and  $\rho$

Physical quantity	SI unit	Equivalence Statement	Unit factor	The actual value of the quantity in non-SI unit(s)	The Quantity in SI unit(s)
Height or distance	$h$	$100 \text{ cm} = 1 \text{ m}$	$\frac{1 \text{ m}}{100 \text{ cm}}$	76 cm	$76 \text{ cm} \times \frac{1 \text{ m}}{100 \text{ cm}} = 0.76 \text{ m}$
Acceleration due to gravity	$g$	$1 \text{ cm s}^{-2} = 10^{-2} \text{ m s}^{-2}$	$\frac{1 \text{ m s}^{-2}}{100 \text{ cm s}^{-2}}$	$980.66 \text{ cm s}^{-2}$	$980.66 \text{ cm s}^{-2} \times \frac{1 \text{ m s}^{-2}}{100 \text{ cm s}^{-2}} = 9.8066 \text{ m s}^{-2}$
Density or mass per unit volume	$\rho$	$10^{-3} \text{ g} = 1 \text{ kg}$ and $1 \text{ cm}^3 = 10^{-6} \text{ m}^3$	$\frac{1 \text{ kg}}{10^3 \text{ g}}$ and $\frac{1 \text{ m}^3}{10^6 \text{ cm}^3}$	$13.595 \text{ gem}^{-3}$	$13.595 \text{ gem}^{-3} \times \frac{1 \text{ kg}}{10^3 \text{ g}} \times \frac{1 \text{ m}^3}{10^6 \text{ cm}^3} = 13.595 \times 10^{-9} \frac{\text{kg}}{\text{m}^3} = 1.3595 \times 10^{-3} \text{ kg m}^{-3}$

Noting that:

$$* (10^3 \text{ cm}^3) / (10^3 \text{ cm}^3) = 1 \text{ m}^3$$

\*\* Density Mass/Volume

Unit factor for mass conversion

\*\*\* Unit factor for density conversion Unit factor for volume conversion

The values of  $h$ ,  $g$  and  $\rho$  from the last column of Table 3.5 are to be substituted in Eq 3.3 to get the SI equivalent of 1 atm pressure.

$$\text{i.e., } 1.0132 \times 10^5 \text{ Pa} = 1.0132 \times 10^5 \text{ kg m}^{-1} \text{ s}^{-2}$$

Hence, SI equivalent of 1 atm is  $1.0132 \times 10^5 \text{ Pa}$ . Using the above illustration, we can sum up the steps for the conversion of non-SI units of a physical quantity into SI units as follows:

- (i) Obtain the equivalence statement relating the SI and the non-SI units.
- (ii) Construct the unit factor.

#### Exercise 4

The value of the gas constant  $R$  is often expressed as  $1.987 \text{ cal mol}^{-1} \text{ K}^{-1}$ . Obtain its value in SI units ( $\text{J mol}^{-1} \text{ K}^{-1}$ ). Given that  $1 \text{ cal} = 4.184 \text{ J}$ .

## 4.0 Conclusion

In this Unit we have attempted to examine some prefixes. We have put you through some rules that must be obeyed while using the SI unit quantities. The method of converting non-SI units into SI units has also been explained. With adequate illustrations, we have been able to convert non-SI units into SI units.

## 5.0 Summary

In this Unit, you have learnt that:

- There are non-SI units and non-SI unit quantities. But to solve any problem given, attempt must be made to convert the non-SI units into SI units before proceeding.
- Some rules for representing SI units exist and must be mastered.
- Converting the non-SI units of  $h$ ,  $g$  and  $\rho$  in c.g.s. units into SI units requires a construction of a unit factor.
- A unit factor is a ratio that is equal to 1.
- Converting the non-SI units of a physical quantity into SI units involves first, obtaining the

equivalent statement relating the SI units and the non-SI units and second, constructing a unit factor.

## 6.0 References and Other Resources

IGNOU (1997). States of Matter: Physical Chemistry CHE-04 New Delhi.

## 7.0 Tutor-Marked Assignment

1. The reduced mass ( $\mu$ ) of two objects of masses  $m_1$  and  $m_2$ , is given by the formula-

$$\mu = \frac{m_1 m_2}{m_1 + m_2}$$

What is the unit of reduced mass?

2. Complete the following conversions:

- (a) 1 mg = ..... kg = ..... g
- (b) 1 s = ..... ms = ..... ns
- (c) 1 km = ..... m = ..... mm.



## Unit 3: Separation Techniques

### Table of Contents

	<b>Page</b>
1.0 Introduction	21
2.0 Objectives	21
3.1 Instrumentation	21
3.2 Reporting Practical Work	23
<b>3.3 Separation Techniques</b>	23
4.0 Conclusion	25
5.0 Summary	25
6.0 References and Other Resources	26
7.0 Tutor-Marked Assignment	26

## 1.0 Introduction

Any course in chemistry requires an appropriate understanding of the apparatus and familiarity with reagents. Similarly, it is important that we are able to follow instruction accordingly when conducting practical work and be honest when reporting our observation and calculations. In this Unit, we will examine the concept of instrumentation as well as various separation techniques you might be applying according to task at hand. Reporting practical work has not been given a relevant place as such, but the Unit will briefly mention some key points.

## 2.0 Objectives

By the end of this Unit, you should be able to :

- Identify some key apparatus and explain their uses.
- Describe the various techniques for separating mixtures.
- State major ways of reporting practical work in chemistry.

## 3.1 Instrumentation

In this section, we will be looking at various instruments that will be needed in the course of studying chemistry. Instrumentation is a skillful process of identifying, substituting and using correct apparatus appropriately in the laboratory. The first task you should carry out is to familiarise yourself with some fundamental and commonly used apparatus in University chemistry laboratory. It is possible to visit the laboratory technician for exposure or training in this area.

Some commonly used apparatus found in the chemistry laboratories are not unrelated to the various experiments designed for that course. Most used instruments include:

1. **Melting point tubes:** These are basically used for determining the melting points of substances. The melting point tube is often used in experiments that cover determination of molecular weight of substances.
2. **Balance:** This is a very important instrument in the laboratory for weighing substances. They vary in types and kinds.
3. **Titration apparatus:** This covers back titration, conductance titration or direct titration. The common apparatus used include pipette, burette, beakers, conical flask, measuring cylinder and volumetric flask. The pipette for instance is calibrated. It is quite essential that whenever experiments are to be performed, you should always make use of the correct technique and **correct measure when using any apparatus.**
4. **Thermometer:** There are different types that are used for measuring hotness or coldness of an object. The Beckman thermometer is used in the Beckman's apparatus for determining the freezing point of a substance. You need to familiarise yourself with this apparatus. A thermometer is also used in other apparatus like simple steam distillation apparatus.
5. **pH meter:** This is for measuring the strength of an acid or base.
6. **Electrochemical cells:** Various types of this exist and you should be able to differentiate. We have the conductance cell also.
7. **Barometer:** This is one type of apparatus, you must know how to use. It is used for measuring pressure and can be found useful in Barometric method of measuring vapour pressure.
8. **An Ostwald viscometer:** It is used for measuring the viscosity of a substance.

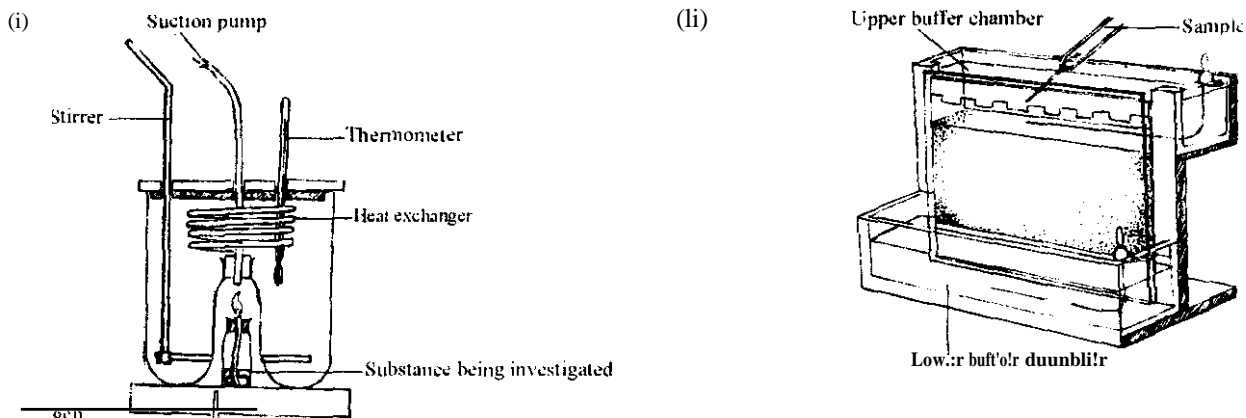

Fig. 3.1: (i) Flame Calorimeter (ii) Page cell

### Exercise I

List the basic steps that you need to follow when measuring with pipette 25 cm<sup>3</sup> of NaOH into a conical flask

\_\_\_\_\_

\_\_\_\_\_

\_\_\_\_\_

Other apparatus include Bomb calorimeter or simple calorimeter, test tubes of different types (micro test tubes, semi-micro test tubes), crucible (e.g. porcelain crucible), chromatographic column, conductivity meter, desiccators, isoteniscope tube, fractional distillation apparatus, conductivity cell and Bunsen burner.

In physical chemistry, there are some fundamental experiments that you must actively participate in. Common activities that you will often engage with in the course of these experimentations include the followings:

- I. Measurements: Often times, many of you find it difficult to measure accurately when you undergo the following tasks
  - (a) Weighing substances using balance:
  - (b) Reading the thermometer:
  - (c) Collecting a specified volume from an unknown quantity using pipette or measuring cylinder

In all, you should avoid using micro experiments are presently advocated.

2. Heating: At secondary school level, hardly do some of you make use of the Bunsen burner. It demands some skills to use, otherwise if not skillfully handled, danger or waste may be involved. It is possible for all the students to melt a solid using a water bath or direct heat using the Bunsen burner flame.
- J. Recording results, drawing and plotting graphs: For this assignment, it is also a crucial task in chemistry practical work. You should be mathematically friendly to calculate and data management. Ability in using a table or spreadsheet, gradient determination or use graph to resolve issues must be constantly practised and developed.
4. Explaining and supporting observations with relevant theories: There is no doubt that you need to do some literature research prior to your practical work.

5. Calculations may include determination of some quantities and functional computations: For instance, you can be asked to determine the solubility of salts in water at a given temperature: electrical conductance: and molecular weight.

### 3.2 Reporting Practical Work

Mostly, reporting is something that is given a place in chemistry even where laboratory manuals are provided. The laboratory manual format varies as the number of lecturers involved. Also the reporting style varies as many as the number of supervisors involving students in practical work. Sometimes, the results and not the procedure are major emphasis of supervisors. There should be some guidelines to place you on the right course when reporting practical work. Let us just mention the major headlines that should always be indicated in your report.

1. The Aim of the Experiment: Every experiment must always have a title indicating the aim or what it is to be achieved by the end of the experiment.
2. Theory: This is the theoretical frame that throws light on the baseline of the experiment. It elicits the conditions, basis and outcomes of the experiments.
3. Apparatus: We need to list out the apparatus as well as the reagents in their definite quantity and measurements respectively. Where a laboratory manual is provided, further readings become necessary for you to be able to carry out the experiment with little or no difficulty.
4. Activities: A brief description of the procedure should be given. Sometimes, the specified instruction in the laboratory manual may deviate partially and or completely from the conditions or steps actually followed. Finally, you will need to provide an explanation why that procedure is adopted by you.
5. Recording Accurately the Result and Errors: There is no experiment that is perfectly done. There is the possibility of some sources of errors which should be reported and could justify the reason for some deviations in the results.
6. Tabulation: Often in chemistry, it is advisable to always tabulate data for effective management, overview and relativity
7. Answers to Questions: In some cases, some questions are raised to enable you relate your findings to theoretical principles or values. Straight forward, very brief and direct answers are expected from you.

### 3.3 Separation Techniques

Most substances as we all know exist in impure form in nature. They require to be made pure before use. A pure substance is a homogeneous material that contains only one substance. Name any pure element you know. Do you say pure crystalline element of diamond? Yes, you are right. There are many impure elements, compounds that you will come across in your study of physical chemistry.

Exercise 2

List 3 impure substances that are solid, liquid or gaseous.

Mostly the impure substances are mixtures. Whether the mixture is homogeneous or heterogeneous, separation techniques could be applied to separate the components. These mixtures are separated using appropriate techniques that depend on:

1. relative solubility of the solute in solvent
2. the absorbent medium
3. the crystalline/non-crystalline: gas/solid/liquid: metallic/non-metallic: organic/inorganic nature of the constituents
4. reaction of the substances to heat (melting, subliming, boiling, etc).

### **Separation Processes**

Make attempt to list the separation processes that can be used to separate mixture constituents. They are evaporation, simple and fractional distillation, sublimation, crystallisation, precipitation and chromatography.

Let us consider each of these processes one by one.

### **Precipitation**

Constituents in a solution mixture can be separated by applying a principle of equilibrium. You will learn about equilibrium in this course. Suppose the mixture components are silver trioxonitrate (V) salt and sodium chloride. These two substances have high solubilities in water. What ions will be formed in the solution mixture? Your list should read  $Ag^+$ ,  $Cl^-$ ,  $Na^+$  and  $NO_3^-$ .

In this solution,  $AgCl$  will be formed.

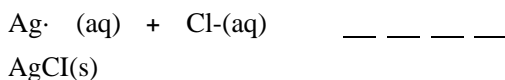

And this is slightly soluble in water. The formation of a solid from a solution is called **precipitation**.

### **Exercise 3**

Consider a mixture containing  $Pb(NO_3)_2$  and  $Mg(NO_3)_2$ ,

- (a) Which of the ions in the mixture can be precipitated?
- (b) Is there any need to introduce another substance? What substance and for what purpose?
- (c) Will  $Mg^{2+}$  precipitate and if no, kindly indicate a reason?
- (d) Write an equation for the reaction?

\_\_\_\_\_

\_\_\_\_\_

\_\_\_\_\_

\_\_\_\_\_

\_\_\_\_\_

**There is no doubt that you will be coming across these processes as you proceed in the course. You will be taken through these methods and as they apply to various mixtures and components**

### **Crystallisation**

This is the process of separating a pure solid from a solution. How is this done, you may ask? This is done by slowly heating the solution until small crystals of salt appear after cooling. There are some conditions that must be obeyed when crystallising. First, steam bath is used instead of direct heating to prevent salt from jumping out of the basin and for safety. Second, the filtration is done while the solution is hot to prevent crystallisation in the crystallising liquid. These crystals can be further washed

with a small quantity of a liquid that will dissolve the crystals. For further purification of the crystals, it can be dissolved in a little hot water and heat slowly as it was initially stated. The impurities are filtered off remaining the pure crystals in the basin.

### Sublimation

You will learn more about these processes but sublimation as a process is also crucial as any other separation techniques. It refers to a process in which the solid directly evaporates without it melting. The change of matter in one phase to another phase will be studied later.

Assuming you are given the following mixtures:

- (a) NaCl + I<sub>2</sub>,
- (b) Solid CO<sub>2</sub> + MgSO<sub>4</sub>,
- (c) Ethanol + FCN

From our discussion FCN(s)  $\rightleftharpoons$  FCN(g)  
 !CN(s)                  ICN(g)

In sublimation, does the tendency toward maximum randomness favour solid or gas? This and many other questions will be answered later.

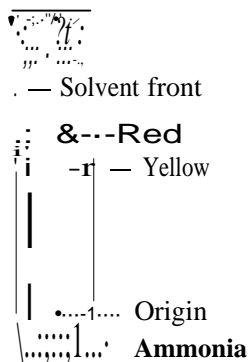

Fig. 3.3

## 4.0 Conclusion

In this Unit we have attempted to examine some essential guidelines that will enable you prepare and function well in laboratory classes. We have put you through some rules that must be obeyed while performing experiments and reporting results. Equally, pure substances are necessary for various products produced for consumption in the market. Thus, we also discussed some of the processes that can be used to obtain pure components in a mixture.

## 50 Summary

In this Unit, you have learnt that:

- Activities we often carried out include weighing and measuring temperature
- We need to develop the skills required for identifying and using instruments.
- The title of an experiment must be written.
- Mixtures are substances we deal with in daily life but they need to be purified through some processes.

## 6.0 References and Other Resources

IGNOU (1997). States of Matter: Physical Chemistry CHE-04 New Delhi.

## 7.0 Tutor-Marked Assignment

1. List three substances that can undergo sublimation.
2. (a) Under what basic principle is fractional distillation employed in separating mixtures"  
(b) What major processes are involved in fractional distillation"

## **MODULE 2: GASEOUS STATE OF MATTER**

### **Unit 1: Gases**

#### **Table of Contents**

	<b>Page</b>
1.0 Introduction	28
2.0 Objectives	28
3.1 General Characteristics of Gases	28
3.2 Boyle's Law	29
3.3 Charles' Law	31
3.4 Combined Gas Law	32
4.0 Conclusion	33
5.0 Summary	<b>33</b>
6.0 References and Other Resources	33
7.0 Tutor-Marked Assignment	<b>33</b>



## 1.0 Introduction

Having discussed the basic and derived SI units in Module 1, Unit 1 and the rules and conversion methods governing their use in Unit 2 of the same Module, the next three or four Units shall be dealing with the gases, both real and ideal gas behaviours. This Unit provides you with the behaviour of gases at certain conditions. However, we shall start with the general characteristics of gases and follow it up with various gas laws and their applications in determining some unknown variables.

## 2.0 Objectives

By the end of this Unit, you should be able to:

- Describe all properties of matter in the gaseous state
- State accurately the Boyle's and Charles' laws
- Explain the gas laws using some illustrations
- Derive correctly the combined gas law
- Determine the unknown variables among pressure, volume and temperature using gas laws and the correct SI units.

## 3.1 General Characteristics of Gases

Matter exists in solid, liquid and gaseous state depending on temperature and pressure. A familiar example is the compound  $H_2O$ , which can exist in ice form, water or steam. The study of the gaseous state is the easiest as gas laws take a simple form at low pressure and high temperature. However, these laws are not valid at all temperatures and pressures. Also the range of validity depends on the nature of the substances itself. In a gas, the molecules on the average are separated by large intermolecular distances. And at such distances, interactions between these molecules are very weak. This is not so in solid and liquids. Hence, the molecules in a gas have greater freedom of motion. As a result of this, they move about randomly and tend to occupy the maximum space available to them. Hence gases do not have any particular shape or volume. Another consequence of their random motion is that each gas molecule collides with other molecules and also with the walls of the container. The constant bombardment against the walls of the container manifests itself as the pressure exerted by the gas.

Let us take the compound water, which we are all familiar with. There is no doubt that it can exist as ice, water or steam. When in solid form, (that is ice) a given mass of it occupies a definite volume and a definite shape. Its volume in liquid shape can be said to be definite too, but how would you describe its shape? Do you hear you say the liquid water assumes the shape of its container? Yes you are right. Does this apply to its gaseous state, steam? What has been your observation when water boils in a covered pot? A given mass of it often occupies the entire volume of its container regardless of the size of the container. Thus, we can say that gases have neither definite volumes nor definite shapes.

At high temperature and low pressure, gases tend to expand. When the temperature is lowered, gases tend to contract. Similarly, they can be compressed almost indefinitely if they exist above a certain critical temperature. The critical temperature is defined as the temperature above which a substance can exist only in the gaseous state.

Assuming you have this gas heated in a rigid container having a fixed volume, what do you say about the pressure at that state? The pressure will of course increase.

Since it is the same volume of a given mass of a gas, when the equations 3.11 and 3.12 are combined, we have

$$\frac{P_1 V_1}{T_1} = \frac{P_2 V_2}{T_2} \quad \dots \dots \dots (3.13)$$

Equation 3.13 is expressed as combined gas law.

#### 4.0 Conclusion

We have gone through the various properties of gases as distinct from other states of matter. Similarly, we have demonstrated the need for SI units in computing the volume, temperature and pressure of gases. From the Boyle's law and Charles' law, we can derive the combined gas law. We have been able to determine some unknown variables when provided with other required conditions using the gas laws.

#### 5.0 Summary

In this Unit, you have learnt that:

- The volume of a fixed mass of gas varies inversely as its pressures at constant temperature.
- The volume of a certain amount of gas at constant pressure is directly proportional to its absolute temperature (T).
- From the Boyle's and Charles' laws, the combined gas law can be derived.
- Real gases do not obey laws exactly for all conditions of temperature and pressure.

#### 6.0 References and Other Resources

IGNOU (1997). State of Matter: Physical Chemistry CHE-04 New Delhi.

#### 7.0 Tutor-Marked Assignment

- I. Give True or False to the following:
  - (a) Volume of a gas is directly proportional to its Celsius temperature.
  - (b) Volume of a gas at constant pressure is inversely proportional to Kelvin temperature.
  - (c) Kelvin temperature is directly proportional to pressure of a gas at constant volume.
2. Express each of the following gas pressures in Pa.
  - (a) 470 torr (b) 2 atms (c) 720 mm Hg
3. What will be the final pressure of a given gas occupying 0.01 m<sup>3</sup> at 1.013 x 10<sup>5</sup> Pa that is compressed to 0.009 m<sup>3</sup> at constant temperature"

## Unit 2: Ideal Gases

### Table of Contents

	<b>Page</b>
1.0 Introduction	35
2.0 Objectives	35
3.1 An Ideal Gas and its Equation of State	35
3.1.1 Unit of R	36
3.1.2 Calculations Using Ideal Gas Equation	36
3.2 Dalton's Law of Partial Pressures	37
3.3 Graham's Law of Effusion	40
4.0 Conclusion	41
5.0 Summary	41
6.0 References and Other Resources	41
7.0 Tutor-Marked Assignment	41

Pressure: The SI unit of pressure is pascal (Pa). Its equivalence with other units of pressure is as follows

$$1 \text{ standard atmosphere} = 1 \text{ atm} = 760 \text{ mm Hg} = 760 \text{ torr} \\ = 101325 \text{ Pa} = 1.01325 \text{ bar}$$

Example ■

What is the force on the Hg base level in a barometer 1 cm<sup>2</sup> cross section having a volume of 76.00 cm<sup>3</sup> at the sea level at 0°C?

Volume: The SI unit of volume is cubic metre (m<sup>3</sup>). Other equivalent units are given below:  
1 m<sup>3</sup> = 10<sup>3</sup> dm<sup>3</sup> = 10<sup>6</sup> cm<sup>3</sup>

In the above expression 'l' stands for litre.

Temperature: The SI unit of temperature is Kelvin (K). To convert temperature from Celsius scale into Kelvin scale, 273.15 is to be added to the former.

What is the composition of air by volume?

Since air is subjected to the gravitational pull of the earth, the atmosphere does not expand indefinitely into space. Moreover, the atmosphere extends above the earth to a height of approximately 10 to 480 kilometers. The force exerted by air on a unit surface area of the atmosphere is termed the atmospheric pressure.

Recall in Unit 1 that pressure is defined as force per unit area. Try to write the SI unit symbol for pressure. Pressure can be measured by using a simple barometer. The pressure of air, which will balance a column of mercury to a height of 76 cm high at a temperature of 0°C at sea level, is termed standard atmosphere.

Let us now state the gas laws

### 3.2 Boyle's Law

In our description of the behaviour of gases in section 3.1 you would recognize that relationship exists between two or more physical quantities. The relationship between the volume and the pressure of a given mass of a gas at a given temperature is known as Boyle's law. This law specifically states that at constant temperature, the volume V, of a fixed mass of gas varies inversely as its pressure, P.

This can be mathematically expressed as:

$$V \propto \frac{1}{P} \quad \dots (3.1)$$

Or  $pV = K$  (Constant temperature)

Here K is a constant at a given temperature for a fixed amount of the gas. This type of behaviour of a gas is shown in Fig 1.1 at two different given temperature. Such a plot at constant temperature is called an isotherm and it resembles a hyperbola. .....(3.2)

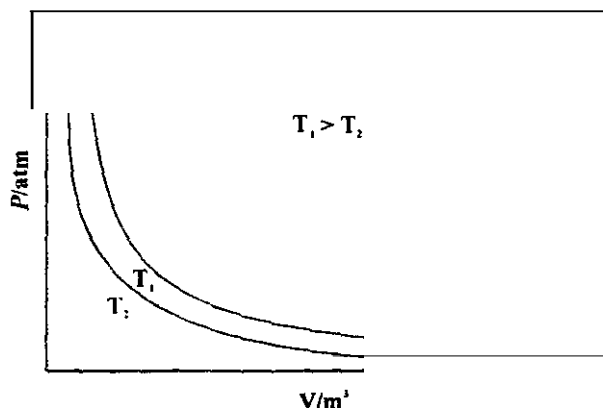

Fig. 1.1: Isotherms at  $T_1$  and  $T_2$

**Exercise 1**

Calculations on Boyle's law:

Assuming a 3.00 litre sample of gas at 1.00 atm is compressed to 0.600 litre at constant temperature. Calculate the final pressure of the gas.

---



---



---



---



---

**Exercise 2**

A sample of gas occupies 360 ml under pressure of  $4.0528 \times 10^5$  Pa (at constant temperature). What volume will the sample occupy at a pressure of  $1.0132 \times 10^5$  Pa?

---



---



---



---



---

Try to recapitulate the SI units of pressure and volume.

**Exercise 3**

Express each of the following gas pressures in Pa: (a) 300 mm Hg  
(b) 0.760 torr (c) 1.5 atm.

---



---



---



---



---

### 3.3 Charles' Law

Assuming we decide to vary the temperature instead of keeping it constant, what do you think will happen to the volume of a given mass of gas at constant pressure?

The pressure is likely to vary linearly with the temperature. This observation describes Charles' law that states:

For a certain amount of gas at a constant pressure, its volume (V) is directly proportional to its absolute temperature (T).

What do we say the SI unit of temperature is? It is Kelvin (K). To convert temperature from Celsius Scale into Kelvin scale, 273.15 is to be added to the former.

$$T = t + 273 \dots\dots\dots(3.3)$$

Try to express this law mathematically as we did for Boyle's law.

$$V \propto T \dots\dots\dots (3.4)$$

$$V = KT \dots\dots\dots(3.5)$$

where K is a constant for a given pressure and amount of gas. Fig. 1.2 depicts the variation of volume with temperature at constant pressure.

Such a plot at constant pressure is called an Isobar and it is a straight line.

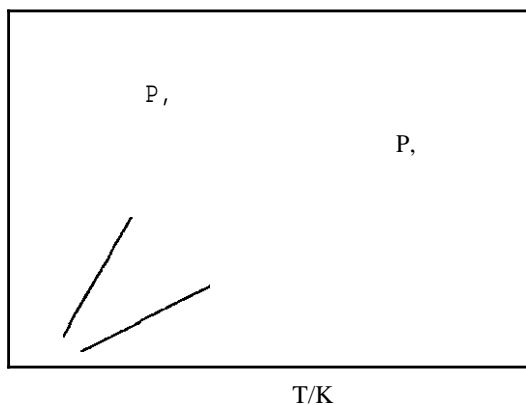

Fig. 1.2: Isobars at  $p_1$  and  $p_2$

#### Exercise 4

1. Calculate the volume which 6.00 litres of gas at 0°C will occupy at 125°C at constant pressure. Draw the isobar.

---



---



---



---



---

2. Draw the isobar if the volume previous at 125°C is further doubled.

\_\_\_\_\_

\_\_\_\_\_

\_\_\_\_\_

\_\_\_\_\_

\_\_\_\_\_

Here are some hints to help you in solving this problem.

Do some conversions of non-SI units to SI units. Note that absolute temperature are required. Write out the mathematical expressions of the 1<sup>st</sup> and 2<sup>nd</sup> conditions.

$$V_1 = KT_1 \dots \dots \dots (3.6)$$

New conditions

$$V_2 = KT_2 \dots \dots \dots (3.7)$$

Combine the separate conditions as follows:

$$\frac{V_1}{T_1} = \frac{V_2}{T_2} = K \dots \dots \dots (3.8)$$

Then calculate after substituting correctly.

The correct answer should be in cubic metre (m<sup>3</sup>)

$$V \propto N \dots \dots \dots (3.9)$$

Where N is the number of molecules in a volume V. But the number of moles (n) is related to the number of molecules (N) as per the equation.

$$n = \frac{N}{N_A} \dots \dots \dots (3.10)$$

Where N<sub>A</sub> is Avogadro's constant (6.022 x 10<sup>23</sup> mol<sup>-1</sup>). Using equations 3.9 and 3.10, we can state that 2. **constant temperature and pressure.**

**V ∝ n**

That is, at constant temperature and pressure, the volume of a gas is proportional to the number of moles of the gas. In other words, equal amount of two gases would occupy same volume at the same temperature and pressure.

Using the above gas laws, we can arrive at the ideal gas equation.

### 3.4 Combined Gas Law

Suppose we desire to examine the volume of a given mass of gas at both varied temperature and pressure. To do this, you may suggest we use, step by step, both the Boyle's law and Charles' law. You are quite correct. But instead of computing independently as you rightly suggest, we can combine the two laws to show simultaneously the inverse proportionality of volume and pressure and direct proportionality of volume and absolute temperature.

Thus, we can have

$$pV = K \dots \dots \dots (3.11)$$

$$\frac{V}{T} = K \dots \dots \dots (3.12)$$

## 1.0 Introduction

So far we have examined the general characteristics of matter in its three states. Specifically gases have neither definite shapes nor definite volume. In Module 1, Unit 3, we described some laws that characterized gaseous state of matter particularly the Boyle's, Charles' and the combined gas laws. In this Unit, we will examine other laws that include equation of state for ideal gas, Dalton's and Graham's laws. It is possible to determine the amount of any sample of gas if the volume, pressure and temperature are known.

## 2.0 Objectives

By the end of this Unit, you should be able to:

- Define correctly an ideal gas.
- Derive the ideal gas equation.
- Calculate one of the unknown amongst pressure, volume, temperature or amount of a gas using the ideal gas equation and the SI units.
- State the Dalton's law of partial pressure and Graham's law of effusion.
- Determine Molar mass, number of moles and partial pressures using all the relevant laws as applicable.

## 3.1 An Ideal Gas and its Equation of State

Recall that Equation 3.13 in Module 2, Unit 1 is a combined gas law of the Boyle's and Charles' gas laws.

$$\frac{pV}{T} = K \quad \dots (3.1)$$

Looking at the combined gas law in Equation 3.13 in Module 2, Unit 1, what do you think K represents? The constant K refers to a given mass and hence a given number of moles of gas. If we replace K with this, we can have the general expression of

$$pV = nR \quad \dots (3.2)$$

$$pV = nRT \quad \dots (3.3)$$

Where n is the number of moles of gas in the sample and R is a gas constant that is applicable to all gases.

Equation 3.3 is known as the equation of state for an ideal gas. The state of the gas is its condition at a given time. Its pressure, volume, temperature and the amount as pointed out in the introduction describe a particular gas. Knowledge of any three of its properties is enough to define completely the state of the gas, since the fourth property can be determined using equation 3.3.

As a matter of fact, no real gas obeys Boyle's and Charles' law. At high pressure and relatively low temperature, real gases deviate from these and other gas laws. The gas that obeys the gas laws exactly for all conditions of pressure and temperature is referred to as an ideal gas.

Let us consider some examples.

### Example 1

What will 10 grams of CO occupy at STP? Assume that CO is an ideal gas.



**Solution:**

We know that

$$PV = nRT$$

And at STP, the pressure is  $1.013 \times 10^5 \text{ Pa}$  at  $273 \text{ K}$

$$\text{Therefore, } V = \frac{nRT}{P} = \frac{(8.314 \text{ J mol}^{-1} \text{ K}^{-1}) (0.73 \text{ mol})}{1.013 \times 10^5 \text{ Nm}^{-2}}$$

$$V = 8.00 \times 10^{-2} \text{ m}^3$$

### 3.1.1 Unit of R

In section 3.3 of Unit I in Module I, you have studied that R has the dimensions of (energy) (amount of substance)<sup>-1</sup> (temperature)<sup>-1</sup>. In SI units, the value of R is  $8.314 \text{ J mol}^{-1} \text{ K}^{-1}$  and we will be using this value throughout this course.

The value of R in different units is given below:

$$\begin{aligned} R &= 8.314 \text{ J mol}^{-1} \text{ K}^{-1} \\ &= 8.314 \times 10^7 \text{ erg mol}^{-1} \text{ K}^{-1} \\ &= 1.987 \text{ cal mol}^{-1} \text{ K}^{-1} \\ &= 0.08206 \text{ L atm mol}^{-1} \text{ K}^{-1} \end{aligned}$$

The R unit to apply will depend on the units chosen to express pressure, temperature and volume.

### 3.1.2 Calculations Using Ideal Gas Equation

Equation 3.3 is useful in calculating any of the unknowns amongst pressure, volume, temperature or the amount of gases from three of the other known quantities. Let us illustrate this.

#### Example 2

Calculate the volume occupied by 0.0660 kg of carbon (IV) oxide gas at a temperature of  $300.2 \text{ K}$  and a pressure of  $9.41 \times 10^5 \text{ Pa}$  assuming ideal behaviour.

#### Solution

$$\text{Number of moles of carbon(IV) oxide (n)} = \frac{\text{mass of carbon(IV) oxide}}{\text{Molar mass of carbon(IV) oxide}}$$

Substituting the values of different quantities in ideal gas equation, we get

$$V = \frac{nRT}{P} = \frac{0.0660 \text{ kg} \times (8.314 \text{ J mol}^{-1} \text{ K}^{-1}) \times (300.2 \text{ K})}{0.044 \text{ kg mol}^{-1} \times 9.41 \times 10^5 \text{ Pa}}$$

$$= 0.0398 \text{ m}^3$$

Using the ideas developed above, attempt the following exercises:

#### Example 3

At  $27.0^\circ\text{C}$ , Nitrogen gas in a  $0.05 \text{ m}^3$  container exerts a pressure of  $5.065 \times 10^5 \text{ Pa}$ . What mass of N<sub>2</sub> is in the container?

### Solution

number of moles of N<sub>2</sub>, n = *f*

$$n = \frac{5.065 \times 10^5 \text{ Pa} \times 0.005 \text{ m}^3}{8.314 \text{ J mol}^{-1} \text{ K}^{-1} \times 300.2 \text{ K}}$$

$$n = 10.15 \text{ moles}$$

$$\frac{\text{Mass}}{\text{Molar mass of } N_2} = 10.15 \text{ moles}$$

Mass = Molar mass x number of moles

$$= 28.0 \text{ g mol}^{-1} \times 10.15 \text{ mol}$$

$$= 284.2 \text{ g}$$

### Exercise 1

Calculate the density of oxygen gas at 273.2 K and  $1.013 \times 10^5$  Pa, assuming ideal behaviour.

(Hints): (i) Number of moles = Mass/Molar mass

(ii) Density = Mass/Volume.

### Exercise 2

How many molecules of oxygen are present in 0.0032 kg of the gas?"

## 3.2 Dalton's Law of Partial Pressures

Suppose we have two samples of two different gases in the same container. If no chemical reaction occurs between them, the total pressure exerted by these two different gases is merely the sum of the individual pressures of the two different gases. In other words, each gas exerts a pressure independent of the other, as if it is the only gas in the container.

The individual pressure of a gas in a mixture of gases is called its partial pressure.

Mathematical form of Dalton's law:

Let us consider three ideal gases, A, B and C. Let the pressure of each gas be P<sub>A</sub>, P<sub>B</sub> and P<sub>C</sub>, respectively when each of them is kept separately at a temperature T and Volume V. Let us force these gases into a vessel of volume V at the same temperature. According to Dalton's law of partial pressures, the total pressure (P) is given by.

$$P_t = P_A + P_B + P_C \quad 3.4$$

Using equation 3.2 for each of the gases we can write

$$p_A = \frac{n_A RT}{V} \quad \dots 3.5$$

$$p_B = \frac{n_B RT}{V} \quad \dots 3.6$$

$$p_C = \frac{n_C RT}{V} \quad \dots 3.7$$

Using equations 3.5 to 3.7 we can write.

$$P_t = (n_A + n_B + n_C) \frac{RT}{V} = \frac{n_t RT}{V} \quad \dots 3.8$$

Where  $n_t$  = total number of moles in the mixture of gases =  $n_A + n_B + n_C$ .

The terms  $\frac{n_A}{n_t}$ ,  $\frac{n_B}{n_t}$ , and  $\frac{n_C}{n_t}$  are called the mole fractions of gases A, B and C, respectively

and are represented as  $x_A$ ,  $x_B$ , and  $x_C$ .

Thus the equations 3.5 to 3.7 can be written as.

$$p_A = x_A P_t \quad 3.9$$

$$p_B = x_B P_t \quad 3.10$$

$$p_C = x_C P_t \quad 3.11$$

Thus, the partial pressure of a gas in a gaseous mixture is the product of its mole fraction and total pressure;

**Let illustrate with some examples how to calculate the number of moles of oxygen gas collected over water under certain conditions**

**Example 4**

Assuming we collect oxygen gas over water at 30.0°C in a 0.25 m<sup>3</sup> gas jar at a total pressure of 2.026 x 10<sup>5</sup> Pa. What is the number of moles of O<sub>2</sub> collected? Check Table 2.1 for the vapour pressure of water at this specified temperature.

Table 2.1: Vapour Pressure of Water at Some Various Temperatures

Temperature(K)	Pressure (Pa)	Temperature (K)	Pressure (Pa)
263	2.86x10 <sup>1</sup>	333	1.99x 10 <sup>1</sup>
268	4.21 X 10 <sup>2</sup>	338	2.50 X 10 <sup>4</sup>
273	6.1 X 10 <sup>2</sup>	343	3.11X10 <sup>4</sup>
293	2.33x 10 <sup>3</sup>	348	3.85 X 10 <sup>4</sup>
298	3.17x 10 <sup>3</sup>	353	4.73 X 10 <sup>4</sup>
303	4.24 X 10 <sup>3</sup>	358	5.78 x 10 <sup>4</sup>
308	5.62 X 10 <sup>3</sup>	363	7.00 X 10 <sup>4</sup>
313	7.37 X 10 <sup>3</sup>	368	8.44 X 10 <sup>4</sup>
318	9.58 X 10 <sup>3</sup>	373	8.44x10 <sup>5</sup>
323	1.23x 10 <sup>4</sup>		
328	1.57x10 <sup>4</sup>		

Example 5

Into one litre container are 14.0 grams of N<sub>2</sub>, 0.20 grams of H<sub>2</sub> and 1.80 grams of O<sub>2</sub>, at 27°C. What is the total pressure in the container?

Solution

Recall from Equations 3.9 to 3.11, the partial pressures of the three gases will be

$$P_{N_2} = \frac{n_{N_2}}{n_t} P_t$$

$$P_{H_2} = \frac{n_{H_2}}{n_t} P_t$$

$$P_{O_2} = \frac{n_{O_2}}{n_t} P_t$$

Let us start with the calculation of the number of moles for each gas.

$$n_{N_2} = \text{mass given} \times \left[ \frac{1 \text{ mole } N_2}{28.0 \text{ grams } N_2} \right]$$

$$n_{N_2} = 14.0 \text{ grams } N_2 \left[ \frac{1 \text{ mole } N_2}{28.0 \text{ grams } N_2} \right]$$

$$= 0.50 \text{ mole } N_2$$

$$n_{H_2} = 0.20 \text{ grams } H_2 \left[ \frac{1 \text{ mole } H_2}{2.0 \text{ grams } H_2} \right]$$

$$= 0.10 \text{ mole } H_2$$

$$n_{O_2} = 1.80 \text{ grams } O_2 \left[ \frac{1 \text{ mole } O_2}{16.0 \text{ grams } O_2} \right]$$

$$= 0.1125 \text{ mole } O_2$$

$$\text{Total moles} = 0.50 + 0.10 + 0.1125 \text{ moles} = 0.7125 \text{ moles}$$

Recall that

$$\text{Total Pressure} = \frac{nRT}{V}$$

Having given you some hints and work out for you the number of the total moles. try to determine the total pressure.

With the example and the principles given. attempt the following Exercises:

**Exercise 3**

2.00 mol of nitrogen, 1.00 mol of oxygen and 2.00 mol of methane are kept in a vessel of volume 0.060 m<sup>3</sup> at 250.2 K. Calculate the total pressure of the mixture of gases and the partial pressure of the individual gases using Dalton's law of partial pressures.

**Exercise 4**

State the name of the gas present in air that has the highest partial pressure.

### 3.3 Graham's Law of Effusion

Effusion is the passage of a gas through a small opening into an evacuated chamber. Graham's law states that the rates at which gases effuse are inversely proportional to the square root of their densities or molar masses under similar conditions of temperature and pressure.

If  $r$ ,  $\rho$  and  $M_m$  are the rate of effusion, density and molar mass of a gas, then

$$\text{Then } r \propto \frac{1}{\sqrt{\rho}} \quad \text{Or} \quad r \propto \frac{1}{\sqrt{M_m}} \quad \dots (3.12)$$

If two gases with molar masses  $M_m$  and  $M_m'$  have densities  $P$  and  $p$ , then their rates of effusion  $r$  and  $r'$  under same conditions of temperature and pressure, are related as,

$$\frac{r}{r'} = \frac{\sqrt{P}}{\sqrt{p}} = \frac{\sqrt{M_m'}}{\sqrt{M_m}} \quad \dots \dots \dots (3.13)$$

Using the equations 3.13. answer the following exercise.

**Exercise 5**

What is the ratio of effusion rate of hydrogen to oxygen?"

## 4.0 Conclusion

In the preceding Unit, we discussed the general characteristics of gases and the combined gas law. In this Unit, we have been able to derive the equation of state of an ideal gas. In addition, we defined an ideal gas and we stated that the real gases do not follow these laws under all conditions of pressures and temperatures. We also performed some calculations by applying the equation of state and other laws.

## 5.0 Summary

At the end of this Unit, you have learnt that:

- An ideal gas is a gas that obeys gas laws exactly for all conditions of pressure and temperature.
- Its pressure, volume, temperature and the amount, describe a particular state of a gas
- When the gases put in the same container at a specified temperature do not react chemically, the total pressure of the pressures is exerted by the individual gases occupying the same volume alone.
- If two gases with molar masses  $M_{m1}$  and  $M_{m2}$ , have densities  $\rho_1$  and  $\rho_2$  then their rates of effusion  $r_1$  and  $r_2$ , under same conditions of temperature and pressure are:

$$\frac{r_1}{r_2} = \sqrt{\frac{M_{m2}}{M_{m1}}}$$

## 6.0 References and Other Resources

Goldberg, David and Dillard, Clyde (1974). College Chemistry 3<sup>rd</sup> Revised Edition New York: Macmillian Publishing Co. Inc.

IGNOU (1997). States of Matter: Physical Chemistry CHE-04 New Delhi.

## 7.0 Tutor-Marked Assignment

1. Calculate the molar mass of a gas for which density is  $1.250 \times 10^3 \text{ kg m}^{-3}$  at 273.2 K and  $1.013 \times 10^5 \text{ Pa}$ .
2.  $1.000 \times 10^{-3} \text{ m}^3$  of argon at a certain pressure and temperature took 151 s to effuse through a porous barrier. How long will it take for the same volume of oxygen to effuse under identical conditions" (Hint: The time taken by a gas to effuse varies inversely as its rate of effusion)
3. A mixture of  $2.00 \times 10^{-3} \text{ kg}$  of  $\text{H}_2$  and  $2.00 \times 10^{-3} \text{ kg}$  of He exerts a pressure of  $1.50 \times 10^5 \text{ Pa}$  What are the partial Pressures of  $\text{H}_2$  and He"

## Unit 3: The Kinetic Theory of Gases

### Table of Contents

	<b>Page</b>
1.0 Introduction	43
2.0 Objectives	43
3.1 Recapitulation of Graham's Law	<b>43</b>
3.2 Postulates of the Kinetic Theory of Gases	44
3.2.1 Resolution of Molecular Velocities	44
3.2.2 Mean Square Speed	45
3.3 Derivation of the Expression for Pressure	411
3.4 Ideal Gas Equation	47
3.4.1 Calculation of Average Kinetic Energy	48
3.4.2 Calculation of Number Density and Concentration	41
3.4.3 Calculation of Mean Square Speed and Root Mean Square Speed	49
4.0 Conclusion	50
5.0 Summary	50
6.0 References and Other Resources	50
7.0 Tutor-Marked Assignment	50

## 1.0 Introduction

By now, we can clearly define a gas as a collection of particles called molecules. In Module 2, Unit 1, we were put through some properties of a gas at low pressure and relatively high temperature. In our course of studying Chemistry we have come to agree that gases behave differently. The differences among them show that their particles behave differently. In this Unit, a molecular interpretation for the different properties of gases will be provided. We shall start by recapitulating specifically the Graham's law of effusion. After this, we shall explain the postulates on kinetic theory of gases and use these to derive an equation that will be useful in calculating the parameters such as pressure, average kinetic energy, etc. of the gas molecules.

## 2.0 Objectives

At the end of this Unit, you should be able to:

- State the six postulates of the kinetic theory of gases
- Explain the molecular velocities
- Derive the equation  $PV = nRT$
- Explain the distribution of molecular speeds
- Calculate the most probable speed and the root mean square speed
- Derive an expression to calculate the collision number between gas molecules.

## 3.1 Recapitulation of Graham's Law

Before we re-examine Graham's law, I want to ask if you have experienced the movement of gas molecules through other gases. Let us consider ammonia gas. Assuming it is released with the air in a laboratory room in which there are no breezes. What do you notice? Do you hear you say it is smelt even in a far corner of the room? This can easily be detected because  $NH_3$  gas molecules diffuse.

Now suppose we allowed the gas molecules to escape from a covered gas jar container through a very small tube hole. What did we call the rate of escape in Unit 2?

Again, what factors of the gas molecules affect the rate of escape?

Yes, you would be right to say diffusion. The diffusion depends greatly on the masses of the gas molecules. You must try to recall the quantitative expression of Graham's law of effusion. Do you know we can separate isotopes using gaseous diffusion methods? This is one of the applications of the Graham's law.

This behaviour of the gas molecules along with other laws can be explained according to the Kinetic theory of gases. How can we do this?

### Exercise 1

Which postulates of the kinetic molecular theory can be used to justify Dalton's law of partial pressure, which you learnt in Unit two? -----



-Consider  $\text{NH}_3$  and  $\text{HCl}$  gases at the same temperature. Since the temperatures are equal the average kinetic energies of their molecules will be equal.

Let us now examine kinetic theory principles.

### Exercise 2

Calculate the ratio of rates of effusion of  $\text{Cl}_2$  and  $\text{NH}_3$ , both at  $0^\circ\text{C}$  and  $1.0132 \times 10^5 \text{ Pa}$ .

## 3.2 Postulates of the Kinetic Theory of Gases

It is interesting to note that the kinetic theory of gas was first propounded by August Krönig in 1856 and Rudolf Clausius in 1857. Other people who also contributed to this theory are Daniel Bernoulli (1738), James Joule (1845-1851), James Clerk Maxwell (1860) and Ludwig Boltzmann (1871)

In the previous section we discussed gas molecules in continuous motion for the gas to be detected soon. The central idea that gas molecules are in continuous motion is called a theory termed kinetic theory of gas.

The six postulates that have been known to explain the kinetic of gases are as follows:

- (1) A gas is composed of a very large number of tiny molecules. The gas molecules are far apart from one another in comparison with their own dimensions. The gas molecules are considered as small hard spheres. The volume of the gas molecules is negligible compared to the total volume occupied by the gas as a whole.
- (2) The gas molecules confined to a container are in a state of constant rapid random motion. They move in all possible directions with different speeds.
- (3) During their motion they collide frequently with each other and with the walls of the container. These collisions are perfectly elastic, which means that the kinetic energy of the molecules before and after collisions is the same. That is the energy may be transferred from one molecule to another during collision but there is no net decrease in kinetic energy.
- (4) At relatively low pressure, there are no intermolecular forces between the molecules i.e., there are no forces of attraction or repulsion between them.
- (5) The collision of these molecules with the container gives rise to a phenomenon called pressure. In other words, the pressure exerted by the gas is due to the force exerted on the walls of the container due to non-stop bombardment of the molecules.

From the other five postulates the ideal gas law is formed and often referred to as the 6th postulate

- (6) The absolute temperature of a gas is proportional to the mean kinetic energy of the molecules present in it.

We shall use these assumptions in the next section. Let us now discuss some of the features regarding molecular velocities that will be required for deriving the equation of state for the gases.

### Resolution of Molecular Velocities

Velocity ( $\vec{v}$ ) is a vector quantity. The components of  $\vec{v}$  in the x, y and z directions are  $v_x$ ,  $v_y$  and  $v_z$ . The speed  $u$  is the magnitude of the vector  $\vec{v}$  and the latter is represented by Eq. (3.1).

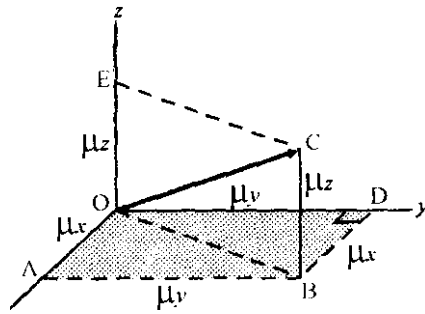

**Fig 3.1:** Components of Velocity. 11

The lengths OA, OD and OE represent the velocity components  $v_x$ ,  $v_y$ , and  $v_z$ . Hence, note that  $OC = v$

$$\begin{aligned} OA &= DB \\ OD &= AB = v_x \\ OE &= BC = v_z \end{aligned}$$

BC is perpendicular to  $xy$  plane (shaded). Since OB is in  $xy$  plane, BC is perpendicular to OB. Hence,  $\angle OBC = 90^\circ$

From the right angled triangle OBC,  $v = OC = OB + BC = OB + v_x$

You can see from the diagram that OD is on  $xy$  plane. Since DB is parallel to  $x$  axis, DB is perpendicular to OD. i.e.  $\angle ODB = 90^\circ$

In the right angled triangle, ODB,  $OB = OD + DB = v_y + v_x$

$$v = OB + v_z = v_x + v_y + v_z \quad \dots \text{3.1}$$

It is important to note that  $v$  is a vector. The speed  $u$  and the velocity components  $v_x$ ,  $v_y$ , and  $v_z$  are scalars. A velocity component like  $v_x$  can be positive, negative or zero (corresponding to motion in the positive  $x$  direction, motion in the negative  $x$  direction or no motion in the  $x$  direction) but must by definition be positive or zero.

### 3.2.2 Mean Square Speed

All the molecules do not move at the same speed. As a result,  $x$  components of the velocities of different molecules are different. This is also true of  $y$  components and  $z$  components of the velocities. If  $v_{1x}, v_{2x}, v_{3x}, \dots, v_{Nx}$  are the square of the  $x$  components of the velocities for the molecules 1, 2, 3, ..., N, then the average of these values,  $u_x^2$  is given by:

$$u_x^2 = \frac{v_{1x}^2 + v_{2x}^2 + v_{3x}^2 + \dots + v_{Nx}^2}{N} \quad \dots \text{3.2}$$

For  $u_y^2$  and  $u_z^2$  also, the expressions similar to Eq. 3.2 can be written. Further similar to Eq. 3.1 the average of the square of the molecular speeds,  $u^2$ , is related to  $u_x^2$ ,  $u_y^2$ , and  $u_z^2$  as

$$u^2 = u_x^2 + u_y^2 + u_z^2 \quad \dots \text{3.3}$$

The quantity  $\overline{u^2}$  is called the mean square speed. Since the gas molecules are in random motion, no particular direction is preferred. The quantities  $\overline{u_x^2}$  and  $\overline{u_y^2}$  are equal. Hence,

$$\overline{u^2} = \frac{(\overline{u_x^2} + \overline{u_y^2} + \overline{u_z^2})}{3} \quad 3.4$$

The above equation will be helpful to you in understanding the derivation described in the next section.

### 3.3 Derivation of the Expression for Pressure

Let us consider the cubical container in Fig. 3.2, with side 'l' filled with N gas molecules. Each gas molecule has a mass 'm'. Let us assume that one of the molecules moves in the x direction with velocity component  $u_x$ .

- I. Distance: A molecule moving along x-direction will strike the shaded wall every  $2l$  (cm) of its path. Do you know why? This is because after an impact with a wall, it will go to the opposite wall, travel a distance  $l$  (cm), return and travel another  $l$  (cm) before the next impact.

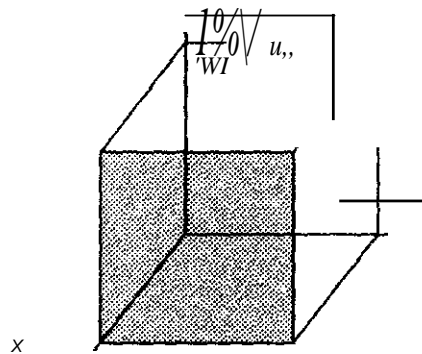

Fig 3.2: Motion of a gas molecule

Thus the distance travelled between collisions =  $l + l = 2l$

2. Number of collisions: What then will be the number of collisions? If a molecule is travelling with a velocity  $u_x$  (cm/sec.) along x-direction, then in 1 sec., it will have travelled  $u_x$  cm and hence made  $\frac{u_x}{2l}$  collisions.

$$\begin{aligned} \text{Number of Collisions} &= \frac{\text{velocity}}{\text{distance between collisions}} \\ &= \frac{u_x \text{ (cm/sec.)}}{2l} \\ &= \frac{u_x}{2l} \text{ (collision/sec.)} \end{aligned}$$

3. Momentum: We know that momentum of the molecule is mass (m) x velocity ( $u_x$ ). If it strikes the wall at the yz plane (shaded face) with momentum  $mu_x$  and will suffer an elastic collision so that it bounces back with a momentum  $-mu_x$ . There is a sign change here, is there not? This is because momentum is a vector quantity.

$$\text{Therefore, the change in momentum in one collision is, } mu_x - (-mu_x) = 2mu_x \quad \dots 3.5$$

4. Force: Now try to define the force exerted by the molecule as a result of impact with the wall. The force will be the momentum change per collision per time per molecule. We can express this as:

Force/mol. = Total change in momentum/time (mol.)

$$= (2mu_x) (u_x/2t)$$

=  $m \overline{u^2} / t$  where  $\overline{u}$  is the average velocity but  $\overline{u} = 0$  and since every direction is equally possible. then

$$\overline{u_x^2} = \overline{u_y^2} = \overline{u_z^2} = 1/3 \overline{u^2} \quad \dots\dots\dots 3.6$$

or

Force per molecule =  $m \overline{u^2} / 3t$  for one molecule

For N molecules, what will be the total force?

$$F = N m \overline{u^2} / 3t \quad \text{that is } m N \overline{u^2} / 3t \quad \dots 3.7$$

5. Pressure: But pressure is Force per unit area. The area of the shaded face is  $A'$

Therefore,  $p = F/A = F/A'$

$$= Nm \overline{u^2} / 3t \times A'$$

$$= Nm \overline{u^2} A' / 3t$$

Since for a cube. volume  $(V) = A' t$

$$P = Nm \overline{u^2} / 3V$$

Therefore.

$$pV = 1/3 Nm \overline{u^2} \quad \dots\dots\dots 3.8$$

We shall use this equation in the next section for calculating the average kinetic energy, number density, concentration, etc. of the gas molecules.

### 3.4 Ideal Gas Equation

Although all the gas laws could be derived from Eq. 3.8. we shall derive the ideal gas equation only and proceed to calculate different molecular parameters.

Eq. 3.8 can be rewritten as.

$$pV = 2/3 N (1/2 m \overline{u^2}) \quad \dots\dots 3.9$$

From the Kinetic theory of gases (postulate 6) it is known that the absolute temperature of a gas sample is directly proportional to the mean kinetic energy of the molecules, i.e.

$$T \propto 1/2 m \overline{u^2}$$

$$\text{Or } 1/2 m \overline{u^2} = K T \quad \dots 3.10$$

where K is constant.

Substituting this in Eq. 3.9. we obtain.

$$pV = 2/3 N K T \quad \dots\dots\dots 3.11$$

This can be written as

$$pV = NkT \quad 3.12$$

where  $k$  is Boltzmann constant is equal to  $2/3k$ . The value of  $k$  is  $1.38 \times 10^{-23} \text{ J K}^{-1}$ . Eq. 3.12 is the ideal gas equation for  $N$  molecules. For a gas having  $n$  moles, the number of molecules  $N$  is given by,

$$N = nN_A \quad 3.13$$

where  $N_A$  is Avogadro's constant and it is equal to the number of molecules (or species) in one mole of a substance. It is equal to  $6.022 \times 10^{23} \text{ mol}^{-1}$ . Hence, the equation in moles of the gas can be written by using Eqs. 3.12 and 3.13

$$pV = nN_A k T = nRT \quad 3.14$$

Where  $R$  is equal to  $N_A k$ .

Let us now calculate some parameters of the gas molecules by the combined use of Eqs. 3.10, 3.12 and 3.14

#### 3.14 | Calculation of Average Kinetic Energy

Average kinetic energy per molecule can be calculated from Eq. 3.10, which states that  $\frac{1}{2} m v_{rms}^2 = \frac{3}{2} kT$

$$\text{Average kinetic energy per molecule} = \frac{3}{2} kT \quad \dots 3.15$$

Similarly, average kinetic energy per mole  $(N)$   $(\frac{1}{2} m v_{rms}^2)$

$$= \frac{3}{2} NkT$$

$$= \frac{3}{2} nRT$$

$$\text{where } R \text{ is } N_A k \quad 3.16$$

The energy calculated using this expression is also called the translational energy: this energy is due to the motion of the molecules in space

Thus, we can see that the translational energy (K.E) of an ideal gas is independent of the type and pressure of the gas. What then do you think it depends on from the equation we derived for the kinetic energy? It depends on the absolute temperature.

#### Example 1

Let us illustrate the use of Eqs. 3.15 and 3.16 in doing some calculations.

Calculation of the average translational energy per molecule

Calculate the average translational kinetic energy values of nitrogen at 300 K

Using Eq. 3.15, the translational energy of nitrogen per molecule at 300 K  $\frac{3}{2} kT$

$$\frac{3}{2} \times 1.38 \times 10^{-23} \text{ J K}^{-1} \times 300 \text{ K}$$

$$6.21 \times 10^{-21} \text{ J}$$

2. Calculation of the average translational energy of nitrogen per mole

Similarly using Eq. 3.16. the translational energy of nitrogen per mole at 300 K  $\frac{3}{2}RT$   
 $\frac{3}{2} \times 8.3141 \text{ mol}^{-1} \text{ K}^{-1} \times 300 \text{ K}$   
 $3.74 \times 10^3 \text{ J mol}^{-1}$

3.4.2 Calculation of Number Density and Concentration

Number density ( $n$ ) is defined as the number of molecules of a gas in unit volume. We can obtain number density by re-arranging the equation.

$pV = NkT$   
 as  
 Number of density of a gas ( $n = N/V = p/kT$ ) ..... 3.17

We can also do this for the concentration of a gas which is defined as the number of moles of a gas in unit volume. What do you obtain when you re-arrange equation?

$pV = nN, kT = nRT$   
 Concentration of a gas ( $c = n/V = p/RT$ ) ..... 3.18

Example 2

Calculate the number density and concentration of nitrogen molecules at 298.2 K and  $1.013 \times 10^5 \text{ Pa}$ . Using Eqs. 3.17 and 3.18.

Number of density ( $n$ ) of nitrogen molecules at 298.2 K  $= p/kT$   
 $\frac{1.013 \times 10^5 \text{ Pa}}{1.38 \times 10^{-23} \text{ J K}^{-1} \times 298.2 \text{ K}}$   
 $2.462 \times 10^{25} \text{ m}^{-3}$

Concentration ( $c$ ) of nitrogen at 298.2 K  $= p/RT$   
 $\frac{1.013 \times 10^5 \text{ Pa}}{8.3141 \text{ mol}^{-1} \text{ K}^{-1} \times 298.2 \text{ K}}$   
 $40.86 \text{ mol m}^{-3}$

You should note that the number density or the concentration of a gas is directly proportional to the gas pressure and inversely proportional to its temperature.

3.4.3 Calculation of Mean Square Speed and Root Mean Square Speed

In section 3.2.2, we have defined mean square speed ( $u^2$ ). The square root of its value is called root mean square speed and is represented as  $u_{rms}$ . For one mole of the gas, combining Eqs. 3.8 and 3.14, we can write

$PV = RT = Mmu_{rms}^2$  ( $n = 1$  and  $Nm = Mm$  Molar mass)  
 $3$   
 i.e. mean square speed ( $u^2$ ) =  $\frac{3RT}{Mm}$  ..... 3.19

Root mean square speed ( $u_{rms}$ ) =  $\sqrt{\frac{3RT}{Mm}}$  ..... 3.20

### Example 3

Let us calculate  $u_{\text{rms}}$  of methane molecules at 515 K using Eq 3.20

$$u_{\text{rms}} = \sqrt{3RT/Mm} = \sqrt{3 \times 8.314 \text{ J mol}^{-1} \text{ K}^{-1} \times 515 \text{ K} / 0.016 \text{ kg mol}^{-1}}$$
$$8.96 \times 10^3 \text{ m s}^{-1}$$

Using the above example, answer the following exercises:

### Exercise 3

Calculate the root mean square speed of hydrogen molecules at 500 K (Molar mass of hydrogen = 0.002 kg).

### Exercise 4

At what temperature will hydrogen molecules have the same root mean square speed that oxygen molecules have at 127°C?

## 4.0 Conclusion

We can conclude by saying that the kinetic theory is applicable to any gas. The theory also accounts for the properties of gases as expressed by the various gas laws we studied in Module 2, Unit I. It is also postulated that since the molecules are in constant random motion and they always get farther apart they fill up any container. In the process, the molecules bombard the walls of the container explaining the existence of pressure by gaseous molecules. However, absolute zero is the temperature at which the molecules can be said to have no translational motion.

## 5.0 Summary

In this Unit, we have learnt that:

- Kinetic theory of gases refers to the idea that gas molecules are in continuous motion.
- The absolute temperature of an ideal gas is proportional to the average translation to the average translational kinetic energy of the molecules present in it.
- The Number density of a gas is the number of molecules of a gas in unit volume.
- The concentration of a gas is the number of moles of a gas in unit volume.
- At any given instant, the molecules in a sample of a gas have a range of velocities.
- One application of Graham's law is the gaseous diffusion method of separating isotopes.

## 6.0 References and Other Resources

Goldberg, David and Dillard, Clyde (1974). College Chemistry 3rd Revised Edition New York Macmillan Publishing Co. Inc.

IGNOU (1997). States of Matter: Physical Chemistry CHE-04 New Delhi.

## 7.0 Tutor-Marked Assignment

- (1) Calculate the molar mass of a gas for which density is  $1.250 \times 10^3 \text{ kg m}^{-3}$  at 273.2 K and  $1.013 \times 10^5 \text{ Pa}$ .

- (2)  $1.000 \times 10^{-3} \text{ m}^3$  of argon at a certain pressure and temperature took 151 s to effuse through a porous barrier. How long will it take for the same volume of oxygen to effuse under identical conditions"  
 (Hint: The time taken by a gas to effuse varies inversely as its rate of effusion.)
- (3) A mixture of  $2.00 \times 10^{-2} \text{ kg}$  of  $\text{O}_2$  and  $2.00 \times 10^{-2} \text{ kg}$  of He exerts a pressure of  $1.50 \times 10^5 \text{ Pa}$ . What are the partial pressures of  $\text{O}_2$  and He"
- (4) Calculate the ratio of mean square speed of oxygen to nitrogen at 300 K.
- (5) Calculate the number density and concentration of oxygen at  $1.013 \times 10^5 \text{ Pa}$  and 300 K.



## Unit 4: Real Gases

### Table of Contents

	Page
1 0 Introduction	<b>53</b>
2 0 Objectives	53
3 1 Deviation from Ideal Gas Behaviour	<b>53</b>
3.1.1 Behaviour of Real Gases	53
3.2 Vander Waals Equation	54
3.3 Critical Phenomena and Critical Points	58
3.4 Critical Constants	58
3.4.1 Critical Constants and Vander Waals Constants	59
3.4.2 Determination of Critical Constants	60
3.4.3 Test for Van der Waals Equation	61
4.0 Conclusion	62
5.0 Summary	62
6.0 Tutor-Marked Assignment	62

## 1.0 Introduction

In Module 2, Units 3 and 4, you learnt that gases do obey ideal gas laws only at low pressures and high temperatures. Furthermore, the gas laws discussed in those two units are based on the postulates of the kinetic theory of gases which were discussed in Module 2, Unit 3. Can you recall the law that says the product of the volume and pressure of a gas at a given temperature should remain constant at all pressures? Yes, you are right by saying it is Boyle's law. In reality gases show deviations from this predicted behaviour of Boyle's law. The real gases also deviate from other gas laws. Thus, to start with, the deviation of the real gases from ideal gas behaviour will be explained to you in this unit. The features of the isotherms at different temperatures will be explained. Afterwards, you will learn to deduce Van der Waals equation. The relationships between critical constants and Van der Waals constants will be derived.

## 2.0 Objectives

At the end of this Unit, you should be able to:

- State the differences in behaviour between real and ideal gases
- Deduce Van der Waals equation
- Define the terms critical temperature, critical pressure and critical volume
- Derive the relationships between the critical constants and Van der Waals constants.

## 3.1 Deviation from Ideal Gas Behaviour

What comes to your mind when the words real and ideal are mentioned? Can you think of the difference between the two? Yes, ideal is perfect. An ideal gas is expected to be a perfect gas irrespective of the conditions. However, it has been found that the gases around are not perfect under **all** conditions. Their characteristics or behaviour deviate from what the perfect gases should be. Thus an ideal gas is a hypothetical concept. The real gases obey ideal gas laws only at low pressures and high temperatures.

The reasons for the deviations of real gases from the ideal gas behaviour are better provided in the assumptions we studied in Module 2, Unit I. First, it is assumed that the volume of the gas molecules themselves is as negligible compared to the volume occupied by the gas in the container. The second reason is the assertion that there are no forces of attraction between molecules. Having given you reasons for the deviations, let us study the behaviour of gases at different pressures and temperature.

### 3.1.1 Behaviour of Real Gases

In Module 2, Unit 1, you will recall that we mentioned four phenomena that could be used to describe the behaviour of a gas. These are volume, pressure, temperature and number of moles. These phenomena can be measured practically for each gas. If that gas behaves ideally, its compressibility factor, which is defined by equation 3.1, must be equal to 1.

$$z = \frac{pV}{nRT} \dots\dots\dots 3.1$$

If  $z$  deviates from the value of unity, the gas is said to deviate from ideal gas behaviour. In Fig 4.1,  $z$  is plotted against pressure for several gases. We notice that all gases approach ideal behaviour at low pressures. This is inferred from the fact that  $z$  approaches unity at low pressure for all gases.

To illustrate the effect of temperature,  $z$  is plotted against pressure for nitrogen gas at three temperatures in Fig. 4.2. Note that the curve at high temperature (673 K) approaches ideal gas behaviour much more than the curves at lower temperatures (203 K and 293 K). This is true of all the gases. To sum up, the gases behave ideally at low pressures and at high temperatures.

For real gases\_ the value of  $z$  is greater than or less than unity.

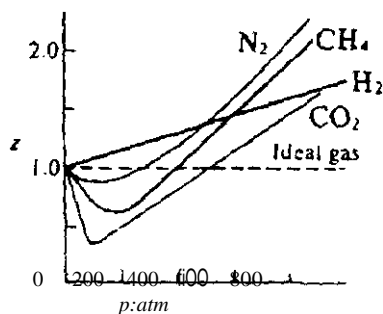

Fig. 4.1: Plots of  $z$  against  $p$  for several gases

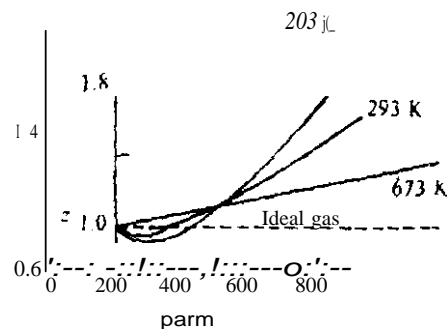

Fig. 4.2: Plots of  $z$  against  $p$  for nitrogen gas at three temperatures

Van der Waals derived an equation of state for explaining the experimental facts of the behaviour of gases. We shall study this in the next section.

### 3.2 Van der Waals Equation

You had learnt earlier about the origin of the deviations of gases from ideal gas behaviour. What are these two assumptions again? Firstly, the volume of a molecule is by no means negligible and cannot be ignored under all conditions. Secondly, there certainly exists intermolecular interaction between molecules at close distances. Van der Waals modified the ideal gas equation by taking into account the above shortcomings.

**Shortcomings:** Two corrections were applied considering the fact that the molecules of a real gas have definite volume; and (ii) the pressure exerted as a result of the number of molecules striking the wall and attracting a molecule from behind.

Let us take the two corrections one by one

**Volume correction:** Van der Waals realized that the molecules of a real gas have definite volume. Therefore, the entire volume ( $V$ ) of the container is not available for the free movement of the gas molecules. The volume available for the motion of the molecules can be given by  $(V-nb)$ , where  $n$  is the number of moles of the gas and  $b$  the correction in volume for one mole of the gas. The quantity  $b$  is known as co-volume.

Hence, corrected volume  $\therefore V_r$ ;  
 $= V - nb$ ..... (32)

**Pressure correction:** Van der Waals applied pressure correction by taking into account the intermolecular forces. The pressure of a gas is due to the collision of the gas molecules on the walls of the container. Consider two identical molecules in a gas such that one is somewhere in the middle of the container and the other just strikes the wall (Fig. 4.3)

The van der Waals constant ' $b$ ' is equal to the excluded volume of one mole of a gas. It can be shown that ' $b$ ' is equal to four times the actual volume of the molecules. This constant ' $b$ ' has the units,  $m^3 \text{ mol}^{-1}$

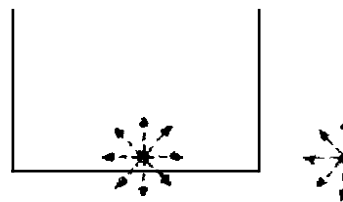

Fig. 4.3: The attraction experienced by the molecules

It can be seen that a molecule in the middle of the container is attracted on all side by the other molecules surrounding it. However, in case of a molecule that just strikes the wall, there is a net backward drag on the molecule and it will strike the wall with a somewhat weakened impact. Hence, the observed pressure (p) of a gas will be less than the pressure exerted by an ideal gas. A pressure correction is therefore needed to be applied. The correction term in pressure (Dp) is proportional to two factors, viz.,

- the number of molecules striking the wall per unit areas and
- the number of molecules attracting a molecule from behind.

Each of the above factors is proportional to the square of concentration of the gas i.e.,

$$Dp \propto (\text{concentration})^2$$

$$\text{But the concentration of the gas} = \frac{\text{Number of moles (n)}}{\text{Volume of the container (V)}}$$

Hence it can be written that,

$$Dp \propto \frac{K}{V^2}$$

$$\text{i.e., } Dp = \frac{n^2 a}{V^2} \tag{3.3}$$

where 'a' is a parameter characteristic of a gas. Hence the corrected pressure (P<sub>corr</sub>) is given by,

$$P_{\text{corr}} = p + \frac{n^2 a}{V} \tag{3.4}$$

If the corrected pressure and the corrected volume of the gas are substituted in the ideal gas equation (Module 2 Unit 2), we obtain

$$(P + \frac{an^2}{V}) (V - nb) = nRT \tag{3.5}$$

This equation is known as Van der Waals equation. Since for one mole of gas, V = V<sub>m</sub> (i.e., molar volume) and n = 1, hence, Eq. 3.5 becomes

$$\left( P + \frac{a}{V_m^2} \right) (V_m - b) = RT \tag{3.6}$$

Van der Waals equation (Eq. 3.5 or 3.6) is quite important and is applicable over a much wider range of p-V-T data than the ideal gas equation. The quantities 'a' and 'b' are called the Van der Waals constants or parameters. The quantities 'a' and 'b' are obtained empirically by fitting values on experimental p-V-T data to Eq. 3.5. It may be pointed that 'b' is a measure of the molecular size and 'a' is related to the intermolecular interaction. Table 4.1 gives the values of the parameters 'a' and 'b' of some selected gases. It can be seen that 'b' increases as the size of the molecule increases whereas 'a' has large value for an easily compressible gas. The values of the critical constants p<sub>c</sub>, V<sub>c</sub> and T<sub>c</sub> are also given in Table 4.1.

Table 4.1: Van der Waals Parameters and Critical Constants of Some Gases

Gas	$\cdot a'/\text{Pa m}^6 \text{ mol}^{-1}$	$10^6 \times \cdot b'/\text{m}^3 \text{ mol}^{-1}$	$W \cdot \chi \text{ PJPa}$	$10^6 \times V_{\text{Jm}^3 \text{ moi}^{-1}}$	$TJK$
He	0.003457	23.70	2.20	57.8	5.21
Ar	0.1373	32.19	48.64	73.3	150.7
H,	0.02476	26.61	12.97	65.0	33.2
O,	0.1378	31.83	50.76	78.0	154.8
N,	0.1408	39.13	33.94	90.1	126.3
CO,	0.3639	42.67	73.66	94.0	304.2
H <sub>2</sub> O	0.5536	30.49	220.89	55.3	647.4
NH <sub>3</sub>	0.4225	37.07	112.5	72.5	405.5
CH <sub>4</sub>	0.2283	42.78	46.41	99.0	191.1

Explanation of the behaviour of gases using Van der Waals equation

Many a time, either one or both the correction terms could become negligible. Let us study these cases.

When 'b' is negligible:

If 'b' is very small, then equation 3.6 becomes.

$$(P + \frac{a}{V_m^2}) V_m = RT \quad \dots\dots\dots 3.7$$

i.e.,  $pV_m = RT - \frac{a}{V_m}$

or  $z = \frac{pV_m}{RT} = 1 - \frac{a}{RTV_m} \quad \dots\dots\dots 3.8$

This shows that under these conditions,  $pV_m$  will be less than  $RT$  or  $z$  will be less than unity. Equation 3.8 will be valid for substances like water vapour for which 'a' is large and 'b' is comparatively small (See Table 4.1). Also for gases such as  $N_2$ ,  $CH_4$  and  $CO_2$  (Fig. 4.1) at moderately low pressures,  $V_m$  is large such that  $(V_m - b)$  is nearly equal to  $V_m$ . Hence, equation 3.8 is applicable for such gases at moderately low pressures.

When 'a' is negligible:

If 'a' is negligible we have

$$p(V_m - b) = RT$$

i.e.,  $pV_m = RT + pb \quad \dots\dots\dots 3.9$

$$z = \frac{pV_m}{RT} = 1 + \frac{pb}{RT} \quad \dots\dots\dots 3.10$$

Hence,  $pV_m$  will be greater than  $RT$  or  $z$  will be greater than unity. Particularly, this is true for hydrogen (Fig. 4.1) and noble gases for which the value of 'a' is small. This is also true for all the gases at high pressures, since then  $\frac{a}{V_m^2}$  is negligible in comparison to  $p$ .

When 'a' and 'b' are both negligible:

When pressure is very low or the temperature is very high, p is small but V<sub>m</sub> is very large. In this case, the correction terms,  $\frac{a}{V_m^2}$  and nb are both negligible in comparison to p and V<sub>m</sub>.

Hence, at very low pressures or high temperatures, the gases obey ideal gas equation and their z value is nearly equal to unity.

Let us now illustrate the use of Equation 3.5 in the calculation of pressure of 2.000 mol of methane at 1.000 K x 10<sup>3</sup> occupying a volume of 5.000 x 10<sup>-2</sup> m<sup>3</sup>.

Re-arranging equation 3.5, we can write,

$$p = \frac{nRT}{V - nb} - \frac{n^2 a}{V^2}$$

From Table 4.1, a = 0.2283 Pa m<sup>6</sup> mol<sup>-2</sup>

$$b = 42.78 \times 10^{-6} \text{ m}^3 \text{ mol}^{-1}$$

substituting the values of the parameters we get,

$$p = \frac{2.000 \text{ mol} \times 8.314 \text{ J mol}^{-1} \text{ K}^{-1} \times 1.000 \times 10^3 \text{ K}}{(5.000 \times 10^{-2} \text{ m}^3 - 2.000 \text{ mol} \times 42.78 \times 10^{-6} \text{ m}^3 \text{ mol}^{-1})} - \frac{(2.000 \text{ mol})^2 \times (0.2283 \text{ Pa m}^6 \text{ mol}^{-2})}{(5.000 \times 10^{-2} \text{ m}^3)^2}$$

$$p = 3.328 \times 10^5 \text{ Pa}$$

Applying van der Waals equation to methane at 1.000 x 10<sup>3</sup> K, the pressure calculated is 3.328 x 10<sup>5</sup> Pa.

Let us also calculate the pressure of methane using the same values of n, T and V but assuming ideal behaviour.

$$p = \frac{nRT}{V} = \frac{2.000 \text{ mol} \times 8.314 \text{ J mol}^{-1} \text{ K}^{-1} \times 1.000 \times 10^3 \text{ K}}{5.000 \times 10^{-2} \text{ m}^3}$$

$$= 3.326 \times 10^5 \text{ Pa}$$

It is interesting to see that the pressure values of methane obtained by Van der Waals equation and ideal gas equation at 1.000 x 10<sup>3</sup> K are more or less same. This indicates that the methane behaves ideally at 1.000 x 10<sup>3</sup> K.

### Virial Equation of State

A number of attempts have been made to propose equation-of state for ideal gases. These are supposed to represent the p-V-T data over as wide range as possible. However, from practical consideration, it is desirable that the equation of state should have only a few adjustable parameters. It should be simple from mathematical point of view.

The most general equation of state proposed by Kamerlingh-Onnes and is known as virial equation of state. In this equation, the pressure is represented as power series of

$$\frac{1}{V_m}$$

$$p = \frac{RT}{V_m} + \frac{B(T)}{V_m^2} + \frac{C(T)}{V_m^3} + \dots$$

The coefficients  $B(T)$ ,  $C(T)$  ... are known as virial coefficients. It may be noted that these depend on temperature. By having sufficient number of terms in this equation,  $p$ - $V$ - $T$  data can be represented to desired accuracy.

In the next section, we shall introduce the critical phenomena and then study the relationship between Van der Waals constants and critical constants. Before that, work out the following Exercise:

#### Exercise I

Calculate the pressure of 2.000 mol of methane at 298.2 K using the other data from Table 4.1 and assuming that it obeys Van der Waals equation. Also calculate its value, if methane were to behave ideally at 298.22 K.

### 3.3 Critical Phenomena and Critical Points

Now that we know that real gases obey ideal gas laws at low pressures and high temperatures, what do you think will happen to a real gas that is subjected to high pressure and sufficiently low temperatures? The gas will liquefy. But we must also realize that there is a temperature above, which the gas will not liquefy: no matter what pressure is applied. This temperature is called the critical temperature ( $T_c$ ) of the substance. The pressure that is required to liquefy a gas at its critical temperature is called its critical pressure ( $P_c$ ). The volume occupied by one mole of a fluid at its critical temperature and pressure is called critical volume ( $V_c$ ). To explain the phenomena better, a series of experiments performed by Andrews will help you out.

Andrews performed a series of experiments and obtained isotherms ( $p$  against  $V$  plots at constant temperature) for carbon dioxide. The results obtained by him are shown in Fig 4.4.

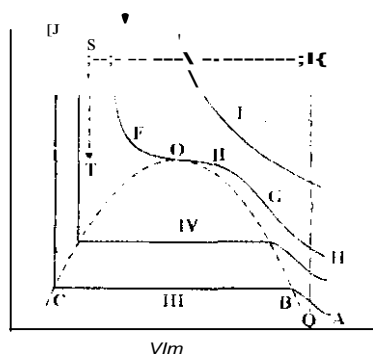

Fig. 4.4: Isotherms of Carbon Dioxide

Finally, let us go through the methods of liquefaction of gases and study the intermolecular forces in general.

At high temperature, the isotherm is a hyperbola (curve I) in accordance with Boyle's law. At low temperatures, the isotherms (the curves II, III and IV) show considerable deviation from ideal gas behaviour. The isotherm at 304.2K (curve II) remains horizontal for a certain value of pressure. The

two falling portions, EFO and OGH. of curve II meet at point O. The point O is known as the critical point; the temperature and pressure at this point are known as critical temperature, T<sub>c</sub>, and critical pressure, p<sub>c</sub>.

### 3.4 Critical Constants

In this section we would examine how critical temperature (T<sub>c</sub>), critical pressure (p<sub>c</sub>) and critical volume (V<sub>c</sub>) are related to Van der Waals constants.

#### 3.4.1 Critical Constants and Van der Waals Constants

The Van der Waals equation (Eq. 3.6) can be made the basis of a theoretical consideration. The curves in Fig. 4.5, known as Van der Waals isotherms, show the isotherms calculated on the basis of this equation.

Expanding Eq. 3.6 we get,

$$(p + a/V_m^2)(V_m - b) = RT \quad \dots\dots\dots 3.11$$

$$\text{i.e., } pV_m - pb + a/V_m - ab/V_m^2 = RT$$

Multiplying the equation throughout by V<sub>m</sub><sup>2</sup>/p, we obtain,

$$V_m^3 - bV_m + aV_m/p - ab/p = RTV_m^2/p \quad \dots\dots\dots 3.12$$

$$\text{i.e., } V_m^3 - V_m^2(b + RT/p) + aV_m - ab/p = 0 \quad \dots\dots\dots 3.13$$

The cubic equation will yield three values for V<sub>m</sub> corresponding to a given pressure and temperature.

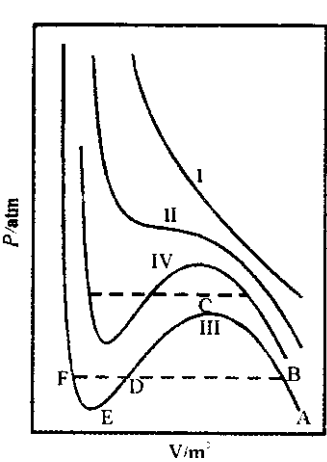

All the three values of V<sub>m</sub> may be real or one may be real and the other two may be complex conjugates. Isotherms III and IV do yield three values of V<sub>m</sub>, in certain ranges of p and V. This is true in general for all isotherms below the critical temperature. Curve II corresponds to critical temperature and curves at higher temperature (such as curve I) approach the isotherm representing Boyle's law. These theoretical curves are similar to those obtained by Andrews for CO<sub>2</sub> but a major difference is the wave like portion BCDEF in the theoretical curves. If experiments are performed without perturbation, then portions BC and EF are realisable, these portions represent the supersaturated vapour and superheated liquid, respectively.

Fig. 4.5: Van der Waals isotherms

The wave like portion decreases as temperature increases. At the critical temperature, it is reduced to a point which means that all the three roots of Eq. 3.13 are identical and equal to the critical volume, V<sub>c</sub>.

$$\text{i.e., } V_m = V_c \text{ or } V_m - V_c = 0$$

We can obtain a cubic equation by raising it to power three, i.e.,

$$(V_m - V_c)^3 = 0 \quad \dots\dots\dots 3.14$$

$$\text{or } V_m^3 - 3V_c V_m^2 + 3V_c^2 V_m - V_c^3 = 0 \quad \dots\dots\dots 3.15$$



This equation should be identical with the expanded form of the Van der Waals equation (Eq. 3.13) at critical temperature and pressure.

$$V_m^3 - V_m^2 \left( b + \frac{RT_c}{p_c} \right) + \frac{a}{p_c} V_m - \frac{ab}{p_c} = 0 \quad \dots\dots\dots 3.16$$

Now, comparing the coefficients of equal powers of  $V_m$  in Eqs. 3.15 and 3.16, we obtain

$$-3V_c = -\left( b + \frac{RT_c}{p_c} \right) \text{ or } 3V_c = b + \frac{RT_c}{p_c} \quad \dots\dots\dots 3.17$$

$$3V_c = \frac{a}{p_c} \quad \dots\dots\dots 3.18$$

$$\text{and } -\frac{ab}{p_c} = -\frac{ab}{p_c} \text{ or } V_c^3 = \frac{ab}{p_c} \quad \dots\dots\dots 3.19$$

From Eqs. 3.17 and 3.19, we obtain

$$\frac{V_c}{3} = b \text{ or } V_c = 3b \quad \dots\dots\dots 3.20$$

Substituting the value of  $V_c$  in Eq. 3.17,

$$p_c = \frac{a}{27b^2} \quad \dots\dots\dots 3.21$$

From Eqs. 3.17 and 3.20, we get

$$\frac{RT_c}{p_c} = (3V_c - b) = 8b$$

$$\text{or } T_c = \frac{8a}{27Rb}$$

$$\begin{aligned} \text{or } T_c &= \frac{8a}{27Rb} \quad \text{(using Eq. 3.21)} \\ &= \frac{8a}{27Rb} \quad \dots\dots\dots 3.22 \end{aligned}$$

Hence, the values of  $p_c$ ,  $V_c$ , and  $T_c$ , can be calculated from the Van der Waals constants

### 34.2 Determination of Critical Constants

Let us study experimental method of determination of critical constants.

#### Critical temperature

Aim: To determine critical temperature.

Apparatus: capillary tube, aluminium block, water, Bunsen burner, thermometer.

#### Procedure:

- Select and evacuate a capillary tube that is able to withstand high pressure.
- Fill it up with the liquid and seal up.
- Place it in an aluminium block having a window
- Heat the set up system gradually.
- Observe closely the meniscus of the liquid through the window.

Repeat it a number of times by varying the temperature in both directions.

#### Observation

You will observe that initially the liquid is in equilibrium with the vapours and a distinct boundary can be seen. But as soon as the critical temperature is reached the boundaries disappear. After repeating this

experiment a number of times by varying the temperature in both directions, you can then take the mean as the experimental value of critical temperature.

**Critical pressure**

The gas under observation is taken in a high pressure vessel at the critical temperature. Initially the gas pressure is kept low. Slowly the gas is compressed at constant temperature. As soon as the vessel inside is covered with mist, it indicates the formation of some liquid and this pressure corresponds to  $P_c$ . Since the pressure is generally much higher than what an ordinary barometer can measure, special pressure gauges are to be used.

**Critical Volume**

Critical volume is determined indirectly based on the findings of Cailletet and Mathies. According to them, a plot of the mean values of the densities of a liquid and its saturated vapour against temperature is a straight line (Fig. 4.6).

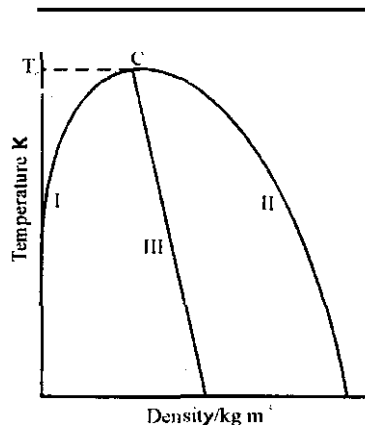

Fig. 4.6: Plot of densities of vapour (I), liquid (II) and their mean values (III) against temperature

It is clear that the density of the vapour (curve I) increases with increase in temperature because the evaporation is higher at higher temperature. But the density of the liquid decreases as temperature increases (curve II). At the critical temperature, the two densities must be equal. However, due to fluctuations it is very difficult to measure the density at  $T_c$ . Hence, the two curves, I and II are extrapolated to intersect the combined curves I and II at C. The density at C, known as critical density, represents the density at  $T_c$ . From this, the critical volume is calculated using the relationship.

$$V_c = \frac{\text{Molar mass}}{\text{Critical density}}$$

Some of the experimental values of the critical constants are already given in Table 4.1.

**3.4.3 Test for Van der Waals Equation**

The calculation of the compressibility factor at the critical point ( $Z_c$ ) based on experimental  $p_c$ ,  $V_c$ , and  $T_c$  values can be a test for Van der Waals equation. Theoretically the values of  $Z_c$  can be derived as follows:

$$Z_c = \frac{p_c V_c}{RT_c} \dots\dots\dots 3.23$$

$$Z_c = \frac{a}{27b^2} \cdot \frac{R T_c}{8a/27Rb} = \frac{P_c V_c}{Z_c R T_c} = \frac{36}{Z_c} \cdot \frac{R T_c}{8a/27Rb}$$

$$= 3/8 = 0.375$$

For most gases, the value of  $Z_c$ , obtained from the experimental values of the critical constants lies between 0.2- 0.4. This variation from the theoretical value of 0.375 indicates the appropriate nature of Van der Waals equation. Why don't you apply these principles in solving the following exercises"

#### Exercise 2

Indane gas supplied for household use is mostly a mixture of propane and butane. Are the critical temperatures of these two gases higher than 298 K"

## 4.0 Conclusion

In this unit, we have been able to examine the reasons for real gases deviation from ideal gas laws at high pressures and low temperatures. Similarly the nature and types of intermolecular forces have been discussed.

Also above critical temperature, a substance can exist only as a gas for the mere fact that the kinetic energies of the molecules are so great that intermolecular attractions are negligible at very high pressures. However, the conditions for liquefaction of gases have been discussed. The volume and pressure corrections in Van der Waals equation are also explained.

## 5.0 Summary

In this Unit, we have learnt that:

- Real gases behave non-ideally at very high pressures.
- The pressure necessary to liquefy a gas at its critical temperature is called its critical pressure.
- The volume occupied by one mole of a fluid at its critical temperature and critical pressure is called its critical volume
- The intermolecular forces include Van der Waals forces, metallic bonding, hydrogen bonding etc
- The deviation occurs due to the presence of intermolecular forces.
- The Van der Waals equation 'corrects' the observed pressure and the observed volume of a real gas to those of an ideal gas as follows:

$$\left( p + \frac{a}{V^2} \right) (V - nb) = nRT$$

## 6.0 Tutor-Marked Assignment

1. A vessel of  $1.000 \times 10^{-3} \text{ m}^3$  volume contains 0.0180 kg of argon at 300 K Calculate its pressure using ideal gas and Van der Waals equations. Use Table 4.1.
2. Why is it that when an ideal gas unlike a real gas is allowed to expand into a vacuum, it would not be cooled?

## Unit 5 Liquefaction of Gases

### Table of Contents

	Page
1.0 IntroductiOn	li4
2.0 Objecti,cs	64
3.1 Liquefaction of Gases	li4
3.1.1 Lmde-s Method	li4
3.1.2 Claude's Method	65
3.2 Intermolecular Forces	lili
2.1 Van der Waals Forces	lili
3.2.2 Total Interaction Energy	6X
3.2.3 Hydrogen Bonding	
3.3 Effect of Molecular Interactions on Ph\ysical Properties	6Y
4.0 ConclusiOn	71
5.0 SununaJ\	71
6.0 References and Other Resources	
7.0 Tutor-Marked Assignment	

## 1.0 Introduction

In the last Unit, we examined the extent to which real gases deviate from ideal gas behaviours. Some explanations to the behaviours of real gases using Van der Waals equation were made. In this Unit, let us examine liquefaction of gases. We will go through the methods of liquefaction of gases and study the intermolecular forces in general.

## 2.0 Objectives.

By the end of this Unit, you should be able to:

- Define liquefaction process
- State the principles of liquefaction methods
- Explain the nature of intermolecular forces, and
- Discuss the effect of intermolecular forces on the condensation of gases into liquids and solids.

## 3.1 Liquefaction of Gases

We have learnt about the liquefaction of air, liquefaction of petroleum gas and even coal. Let us quickly look at the concept of liquefaction. What does it mean? Do you say it is concerned with obtaining liquid from gas or solid? You are right. Liquefaction is a process of making a gas or solid to become liquid. How can we make a solid to become liquid? We can make a solid become liquid by melting and a gas can be changed to liquid by condensation. The critical phenomena and our knowledge of the critical constants are practically useful in the liquefaction of gases. The liquefaction of air is important in the manufacture of nitrogen and oxygen which are both important industrial chemicals. The liquefied petroleum gas (mixture of propane and butane) is used as a domestic fuel. Liquid helium and nitrogen are particularly important for making the materials superconducting. Easily liquefiable gases such as ammonia and dichlorodifluoromethane (Freon) are used in refrigeration and air conditioning.

Let us now study some methods of liquefaction of gases. It has already been clarified that a gas cannot be liquefied above its critical temperature. Many substances like water, ethyl alcohol, etc., have high critical temperatures and hence exist as liquids even at room temperature. Others like ammonia, sulphur (IV) oxide, etc., under ordinary conditions are above their critical temperature but can be easily liquefied by cooling using freezing mixtures under moderate pressure. This implies that the freezing mixture lowers the temperature of a substance below its critical temperature and the moderate pressure is then sufficient to liquefy the gas. On the other hand, there are many gases like oxygen, nitrogen, hydrogen and helium whose critical temperatures are much lower. Special methods are adopted to cool these gases below their critical temperature. Let us study the principles of two of the common methods of liquefaction.

### 3.1.1 Linde's Method

The method is based on the principle known as Joule-Thompson effect. According to this effect when a gas under high pressure is allowed to expand into a region of low pressure, its temperature falls. The gas does not do any external work but the kinetic energy of the molecules expends some work to overcome the attractive forces between the molecules. As a result, the temperature of the gas is lowered. A precaution is required in this process. Do you know why? It is because to have a cooling effect, a gas is to be brought below a characteristic temperature, known as inversion temperature, before allowing it to expand. If the temperature of the gas is above its inversion temperature, Joule-Thompson conversion results in heating.

The schematic diagram of the equipment used is shown in Fig. 5.1

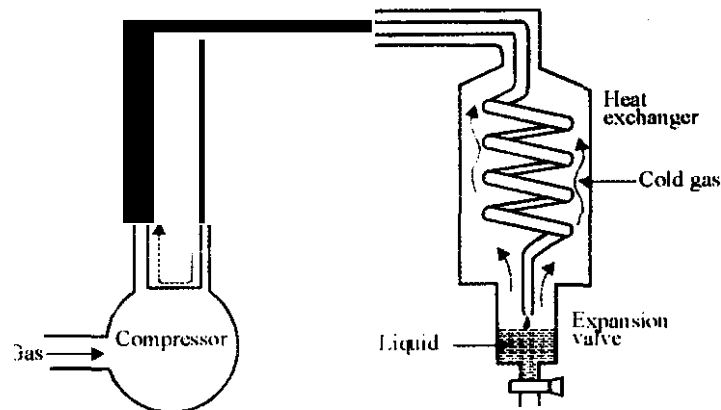
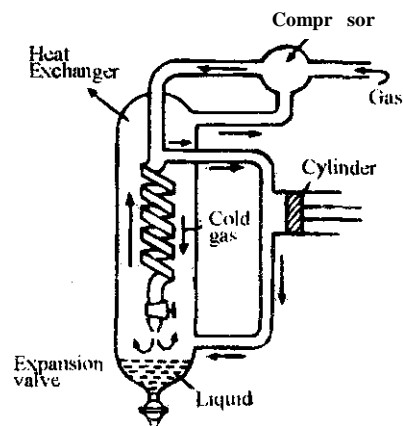

**Fig. 5.1:** Liquefaction using Linde's method

The gas at a temperature lower than its inversion temperature is compressed using a compressor. This gas is then allowed to expand through a valve which results in its cooling. The cold gas is used in cooling the high-pressure gas in the heat exchanger and is recirculated through the compressor. It gets cooled still further, as it expands. The cycle continues till the liquefied gas drops from the throttle

### 3.1.2 Claude's Method

Claude's method (Fig. 5.2) is more efficient than Linde's method. The compressed gas in the insulated vessel (i.e., under adiabatic conditions) is partly used to do work against a piston in a cylinder and partly expanded through a valve. The cooled gas obtained by adiabatic expansion is used for cooling the incoming gas in the heat exchanger. The process is repeated till the gas is liquefied.



**Fig. 5.2:** Liquefaction using Claude's method

Using the principles of Linde's method, answer the following question.

### Exercise 1

If Hydrogen gas is allowed to undergo Joule-Thompson expansion at room temperature, it is heated but not cooled. Explain.

## 3.2 Intermolecular Forces

In section 3.3 of Module 2, Unit 4, we studied that the real gases deviate from the ideal gas behaviour because of the presence of intermolecular forces. The intermolecular forces are also responsible for the conversion of gases into liquids and solids. Van der Waals not only derived an equation to explain the behaviour of real gases but also to develop a model that would explain the behaviour of liquids. In recognition of his work, the weak intermolecular forces in liquids and solids are often called Van der Waals forces.

### 3.2.1 Vander Waals Forces

Van der Waals forces include:-

- (i) Dipole-dipole interactions
- (ii) Dipole-induced dipole interactions
- (iii) London or dispersion forces

Let us study them one by one in details.

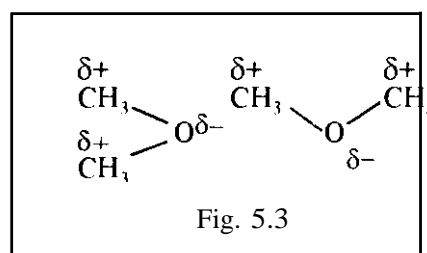

#### Dipole-Dipole Forces

Polar molecules can attract each other electrostatically. During this attraction the positive end of one molecule is close to the negative end of the adjacent molecule, as shown in Fig. 5.3.

Such an attraction is called dipole-dipole interaction. In the liquid state, although molecules are in continuous motion, they tend to align themselves so that, on the average, the intermolecular attractions are maximum.

The interaction energy ( $V_{dd}$ ) between two polar molecules separated by a distance  $r$  is found to be directly proportional to the square of the product of the dipole moments of the two molecules. Inversely proportional to temperature and also inversely proportional to  $r^6$ .

$$\text{i.e., } V_{dd} \propto \frac{\mu_1 \mu_2}{r^6}$$

#### Dipole-Induced Dipole Interaction

The dipole-dipole interaction can explain the attractive forces between polar molecules at ordinary temperatures whereas at high temperatures it cannot. It was thought that induced dipole interaction must also be important. A polar molecule can induce a dipole moment in a neighbouring polarisable atom or molecule. Let us explain the terms 'polarisable' and 'polarisability'. An atom or molecule is said to be polarisable, if its electron cloud can be distorted. The ability of a species to undergo electronic distortion is described in terms of 'polarisability'. The electron charge cloud of a larger atom (one with higher atomic number) can be easily distorted due to the following reasons:

- The electrons are more in number
- The influence of the nucleus is less due to larger distance.

So a larger atom has a higher polarisability than a smaller atom. For example, argon has higher polarisability than helium. Similarly larger molecules (due to greater number of electrons) have higher polarisability than smaller molecules. For example, ethane is more polarisable than methane; propane is more polarisable than ethane, and so on.

The dipole-induced dipole interaction between a polar molecule and a neighbouring polarisable molecule (in which dipole is induced) causes a lowering of energy. That is, such an attractive interaction adds to the stability. The interaction energy ( $V_{i-d}$ ) between a dipole and an induced dipole separated by a distance  $r$  has been estimated to be

- Directly proportional to the square of the dipole moments of the polar molecule,
- Directly proportional to the polarisability of the molecule (in which dipole is induced).
- Inversely proportional to the sixth power of  $r$ .

(i.e.  $V_{i-d} \propto \frac{1}{r^6}$ )

Unlike dipole-dipole interaction, dipole-induced dipole interaction is independent of temperature

#### Induced Dipole-Induced Dipole or London or Dispersion Interaction

The two interactions mentioned earlier cannot explain the liquefaction of gases like hydrogen, oxygen, chlorine, helium and argon – which are all non-polar. London gave an acceptable quantitative explanation for the attractive forces existing between nonpolar molecules and hence such forces are called London forces. These forces are called dispersion forces since the oscillations producing the attractive forces are also responsible for the dispersion of light by the molecules.

To understand the origin of this interaction, let us consider a pair of helium atoms. On the average, the charge cloud around a helium atom is symmetrical. But the electrons surrounding the nucleus of the helium atom are in constant motion. Because of this, the helium atom can develop a momentary non-symmetrical electron distribution. This results in a temporary dipolar arrangement of charge, otherwise known as instantaneous polarity. This helium atom that has instantaneous polarity can then induce a dipole in the neighbouring helium atom. This is illustrated in Fig. 5.4.

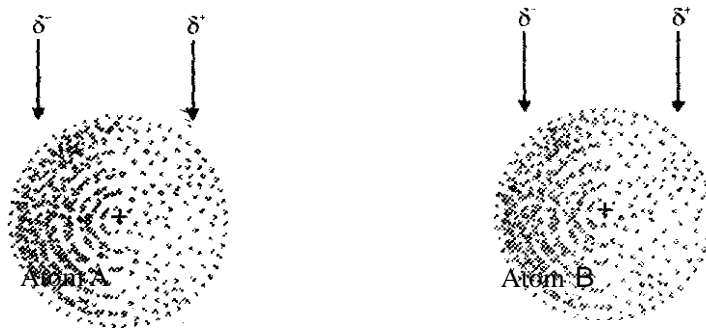

Fig. 5.4: Instantaneous dipole on atom A induces a dipole on atom B.  $\delta^-$  and  $\delta^+$  refer to dipolar charges and  $c$  stands for the nucleus

The resultant induced dipole-induced dipole attraction is both weak and short-lived. But this can be very significant for large atoms (or molecules) that have high polarisability. For these interactions to become strong enough to produce a solid or a liquid, thermal motions must be decreased. This explains why noble gases



elements have low liquefaction temperatures. The interactions explained above are also responsible for the liquefaction of non-polar molecules like  $H_2$ ,  $CH_4$ ,  $CCl_4$  and  $CO_2$ .

The interaction energy ( $V_{ij}$ ) between two noble gas atoms or two non-polar molecules separated by a distance  $r$  is

- Directly proportional to the product of the polarisability of the two species
- Inversely proportional to the sixth power of  $r$

(ie.  $V_{ij} \propto \frac{1}{r^6}$ )

### 3.2.2 Total Interaction Energy

All the three types of interactions explained above are attractive in nature and can account for the cohesive forces responsible for liquefaction of gases. It must be remembered that repulsive forces also operate when molecules are brought too close. It has been estimated that the interaction energy due to repulsion ( $V_{rep}$ ) is inversely proportional to the twelfth power of  $r$ .

i.e.  $V_{rep} \propto \frac{1}{r^{12}}$

The sum of the attractive and repulsive energies is the total interaction energy ( $V$ )

This equation can be written as  $V = V_{rep} + V_{at}$

$$V = \frac{E_{rep}}{r^{12}} + \frac{E_{at}}{r^6} \quad 3.2$$

Where the first term in the right hand side stands for repulsive interaction  $V_{rep}$  (+ve sign); and the second term for the sum of all attractive interactions, viz.  $V_{vdw} + V_{dip} + V_{ind}$  (-ve sign). The terms  $p$  and  $q$  are characteristic of the molecules under study. Eq. 3.2 implies that the molecules have attractive forces (proportional to  $r^{-6}$ ) and repulsive forces (proportional to  $r^{-12}$ ).

The effect of attractive and repulsive interactions on the energy of a system can be understood by plotting the values of  $V$ , against  $r$ . Fig 5.5 shows an example of such plot drawn for methane molecules. By convention, the total interaction energy of the two methane molecules separated by infinite distance (represented by the point A) is zero. When the two molecules are brought closer, they begin to attract one another and there is decrease in the total interaction energy. The falling portion ABC of the curve indicates this. At C, the two molecules have the lowest energy. If the two molecules are brought still closer, repulsive forces overtake the attractive forces and the total interaction energy starts increasing. The rising portion CD of the curve indicates this. It is important you note that the decrease in  $V$ , due to attractive forces (along ABC) is gradual but the increase in  $V$ , due to repulsive forces (along CD) is very steep (Guess the reason).

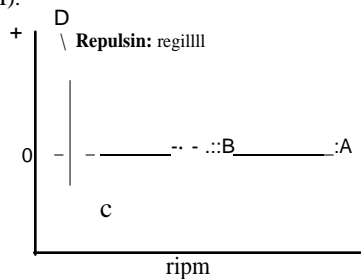

Fig. 5.5: Total interaction energy as a function of intermolecular distance

## J.;U Hydrogen Bonding

There are several specific types of interactions encountered between various types of molecules. Of these, metallic bonding and hydrogen bonding are very significant. We shall study metallic bonding in Module 3, Unit 2. Here let us study hydrogen bonding in detail. When a hydrogen atom is covalently bonded to a strongly electronegative atom, such as oxygen, fluorine or nitrogen, the bond is highly polar. Such a hydrogen atom would still possess large affinity for non-bonding electrons present on other oxygen, nitrogen or fluorine atom. The latter atom could be a part of the same molecule or a neighbouring molecule. The strong interaction that results is called a hydrogen bond. It is a special type of dipole-dipole attraction. In water, for example, hydrogen bonding arises between hydrogen atom (positive end of the dipole) of one water molecule and the oxygen atom (negative end of the dipole) of the other (Fig. 5.6a). Hydrogen fluoride is another molecule having hydrogen bonding (Fig. 5.6b).

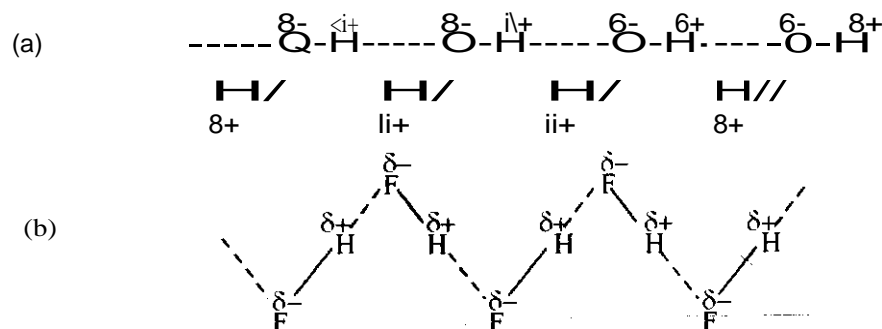

Fig. 5.6: Hydrogen bonding: (a) in water (b) in hydrogen fluoride

Hydrogen bonding is strong in HF, H<sub>2</sub>O and NH<sub>3</sub>, as compared to many hydrides due to the higher electronegativity of fluorine, oxygen and nitrogen. Strong hydrogen bonding in these compounds results in enhanced attractive interactions between the molecules.

Let us study the effect of the above interactions on the physical properties of the compounds

### 3.3 Effect of Molecular Interactions on Physical Properties

Intermolecular forces have significant effect on the physical properties such as melting point, boiling point, solubility, surface tension, density and so on. Here, we consider the effect of intermolecular forces on melting and boiling points only, since these two concern change of state.

(i) Polar molecules have higher melting and boiling points than the non-polar molecules of similar molecular size. It is so since in the polar molecules, in addition to London forces, dipolar interactions are also present. In general, we can conclude by saying the larger the dipole moment, the higher the melting and boiling points. See some illustrative data in Table 5.1.

Table 5.1: Effect of Dipole-Dipole Interaction on Melting and Boiling Points

Compound	Relative molecular mass	Dipole moment 10 <sup>3</sup> "Cm	Melting point/K	Boiling Point/K
C <sub>2</sub> H <sub>6</sub>	30.1	0	89.7	184.4
CH <sub>3</sub> F	34.0	6.17	1312	194.6
SiH <sub>4</sub>	32.1	0	88	1612
PH <sub>3</sub>	34.0	1.93	140	185.3
H <sub>2</sub> S	34.1	3.24	187.5	212.3

- (ii) Among the noble gases\_ the boiling point increases with atomic number (Table 5.2). As explained earlier\_ the London forces are more in large atoms due to higher polarisability.
- (iii) Among a series of similar non-polar molecules such as hydrocarbons. boiling point increases with the molecular size (Table 5.2). Again. the reason is that a larger molecule has higher polarisability and increased London forces.
- (iv) Among the hydrides of 5. 6 and 7 group elements in the periodic table. those havmg the highest boiling points are  $\text{NH}_3 \cdot \text{H}_2\text{O}$  and  $\text{HF}$ . respectively\_ This is due to the strong hydrogen bonding in these three compounds

Table 5.2: Effect of London Forces on the Boiling points

Noble gas	Atomic number	Boiling point/K
He	2	4
Ne	10	270
Ar	18	87.3
Kr	36	120.7

Compound	Relative molecular mass	Boiling point/K
$\text{CH}_4$	16	111.5
$\text{C}_2\text{H}_6$	30	184.4
$\text{C}_3\text{H}_8$	44	231
$\text{C}_4\text{H}_{10}$ (butane)	58	272.4

- (v) There is a striking contrast in the boiling points of the isomeric compounds. ethanol (351 K) and dimethyl ether (249 K)\_ The hydrogen bonding between the molecules of ethanol (Fig. 5.7) contributes to a much higher boiling point On the other hand. the molecules of dimethyl ether are held together only by weaker dipole-dipole interaction (Fig. 5.8)

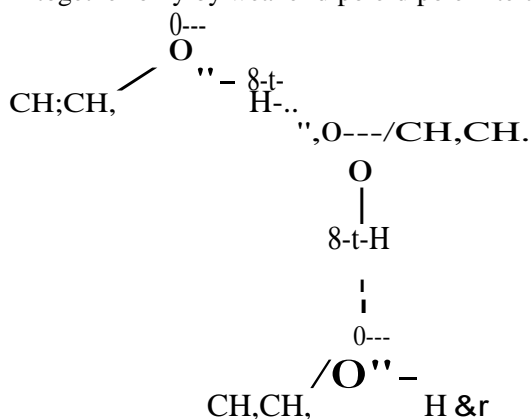

Fig. 5.7: Hydrogen bonding in ethanol

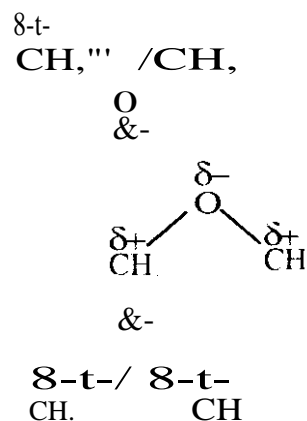
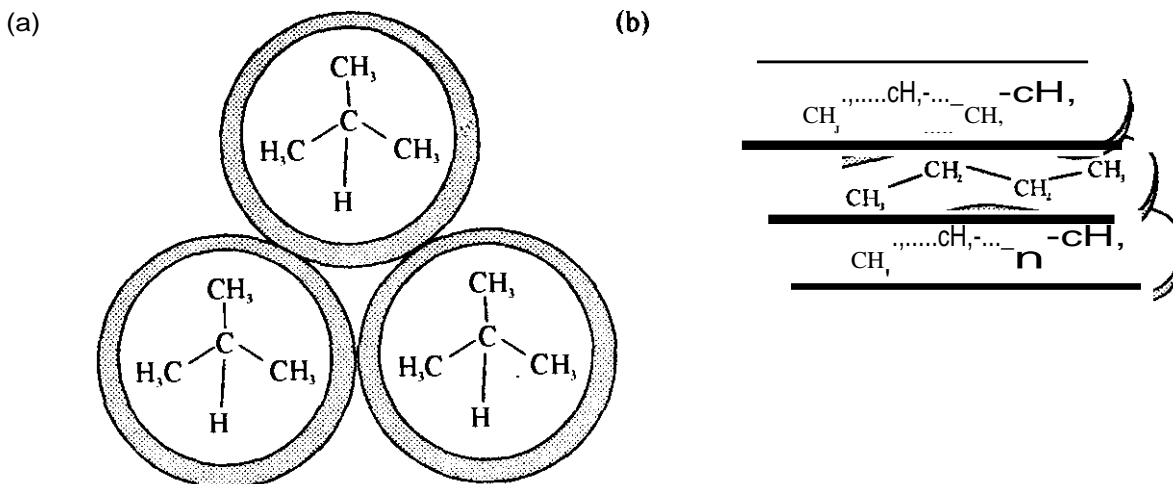

Fig. 5.8: Dipole-dipole interaction in dimethyl ether

- (vi) London forces also depend on the molecular geometry For example. among the isomeric hydrocarbons\_ straight chain Isomer has higher boiling point than the branched chain Isomer Let us illustrate this with a specific example. The straight chain isomer. butane. boils at 272.4 K whereas the branched isomer. 2-methylpropane. boils at 263 K. The molecules of 2-methylpropane are nearly spherical whereas those of butane are distorted rod-like (Figs 5.11a and b)



**Fig. 5.9:** (a) Interaction among nearly spherical molecules of 2-methylpropane  
(b) Interaction among distorted rod-like molecules of butane

Hence, the molecules of butane have a larger area for interaction with each other than those of 2-methylpropane. The stronger interactions in butane are reflected in its higher boiling point.

Care must be exercised in comparing the physical properties of molecules differing sharply in more than one way, viz., relative molecular mass, polarity and geometrical shape. Based on the principles developed above, answer the following exercise.

### Exercise 2

The melting points of  $\text{Cl}_2$ ,  $\text{Br}_2$ ,  $\text{I}_2$  are 172 K, 266 K and 386 K respectively. Explain this variation.

## 4.0 Conclusion

Two methods of liquefaction of gases have been described. These are the Linde's and the Claude's methods. The nature and types of intermolecular forces have been discussed. Finally, we described the effect of intermolecular forces on the melting and boiling points of molecules.

## 5.0 Summary

At the end of this Unit you have learnt that:

- Liquefaction is a process of obtaining liquid from solid or gas through melting or condensation processes.
- The liquefaction of gases can be performed using Linde's and Claude's methods but the latter is more efficient than the former.
- The temperature above which the gas will not liquefy no matter what pressure is applied is termed the critical temperature.
- Physical properties of molecules, such as melting point, boiling points, solubility, etc., are significantly affected by the intermolecular forces existing between the molecules.

## 6.0 References and Other Resources

IGNOU (1997) States of Matter: Physical Chemistry CHE-04 New Delhi.

## 7.0 Tutor-Marked Assignment

1. Why is the liquefaction of gases easier at low temperatures and high pressures?
2. Ethanol has higher boiling point than butane although the latter has higher relative molecular mass. Explain.

## **MODULE 3: SOLID AND LIQUID STATES OF MATTER**

### **Unit 1: Solid States and Solid Types**

#### **Table of Contents**

	<b>Page</b>
1.0 Introduction	7-1.
2.0 Objectives	
3.1 Types of Solids	
3.2 Definition of Terms Used in Crystal Systems	
3.2.1 Lattice	75
3.2.2 Basis	75
3.2.3 Unit Cell	75
3.3 Bravais Lattices and Crystal System>	
3.3.1 Cubic System Geometry	78
3.3.2 Bravais Lattice	78
4.0 Conclusion	79
5.0 Summary	79
6.0 References and Other Resources	80
7.0 Tutor-Marked Assignment	X0

## 1.0 Introduction

In the earlier Units, we had drawn a comparison among the three states of matter- solid, liquid and gas. These states of matter were described in terms of a few physical properties like 'solids are denser than liquids or gases' or 'it takes enormous pressure to compress a solid even by a fraction of the volume'. etc. However, instead of defining the states of matter in terms of the physical properties, it is much more useful to think in terms of the binding forces (ionic, covalent, Vander Waals, etc.) involved in a particular state imparting different properties to solids, liquids and gases. In the next two units, we will be discussing solids. Specifically, this Unit focuses on the definition of solid state, types of solids, crystal systems and definitions of terms used in crystal systems.

## 2.0 Objectives

By the end of this Unit, you should be able to accurately:

- Define lattice, basis, unit cell, primitive and non primitive cells.
- Describe the seven crystal systems and the fourteen Bravais lattices.
- Identify the face, corner, edge, face-centre and body-centre in a cube.

## 3.1 Types of Solids

From what we have discussed in Module 2, Unit I, what do you consider to be a solid state? You are free to read through Unit 3 of the same Module again especially where solids are described in comparison with liquids and gases. Solid state could be defined as a state of a substance in which the neighbouring particles movement (or the molecules) is restricted with respect to its neighbours. Solids can be classified in two ways:

First, the solids can be of two types- *Crystalline* and *Amorphous*. Let us explain what a crystalline solid is. Those solids, which are formed due to regular repetition of identical building blocks, are called crystals. It is like having a collection of identical bricks which could be arranged in some regular fashion to construct a wall. On the other hand, there are solids which do not appear to have any regular internal arrangement in every part and thus do not show regular shape: these are called amorphous solids. Amorphous solid means a solid without regular form. Glass, polythene as in plastic bags, etc., are common examples of amorphous substances.

Crystalline solids compared to amorphous have definite heat of fusion, definite crystal lattice and definite melting point. Can you easily identify a solid substance as crystalline or amorphous by mere looking at it? Do you say yes? To some extent yes. But it is not possible in all cases to say convincingly that a solid is crystalline or amorphous until the solid is examined under a microscope. The microscope reveals easily and clearly the crystalline nature or otherwise of the solid. In fact, their liquids behave differently from the liquids of amorphous upon cooling. You will learn more about the difference at a higher level.

The second way is to classify solids into four, namely:

1. Macromolecular solids
2. Discrete molecular solids
3. Metals
4. Ionic solids

## 3.2 Definition of Terms Used in Crystal Systems

We have already seen that a crystal is defined in terms of a regular and repetitive arrangement of particles (atoms/ molecules/ ions) in space. In order to understand crystals and their structures, we

encounter a few new terms. These terms form a kind of crystallographic language. us now look at the definitions of some of these terms.

### 3.2.1 Lattice

Lattice is defined as an arrangement of geometrical points in a definite pattern in space (Fig. 1.1a). It resembles a scaffold (a framework) erected for the construction of a building. Putting it in a simpler way, one can define a lattice as a regular periodic arrangement of points in space.

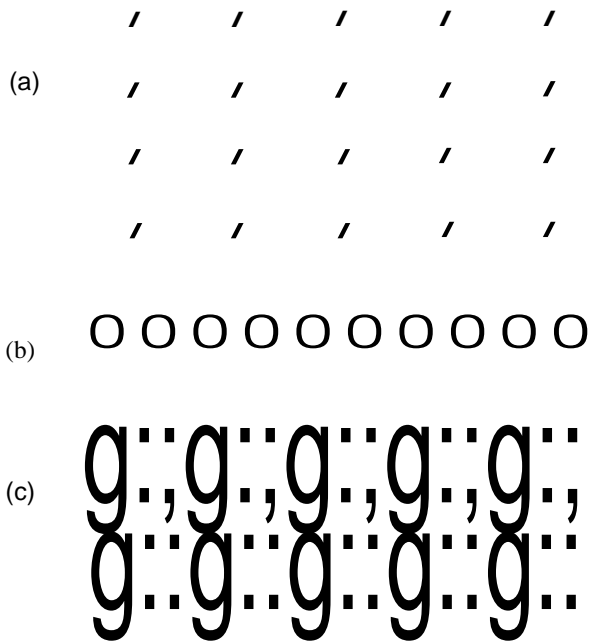

**Fig. 1.1:** Representation of (a) lattice in two dimension (b) basis {with two atoms} (c) crystal structure showing the basis of two atoms in relation to lattice points

### 3.2.2 Basis

When atoms are attached regularly to each lattice point, it forms a crystal. However, instead of an atom, we can have a group of atoms attached to each lattice point. The group is called a basis (Fig. 1.1 b). The basis consists of the atoms, their spacings and internal bond angles. Every basis is identical in composition, arrangement and orientation. Fig. 1.1 shows the structure where you can recognize the basis and imagine the lattice. For a large number of crystals, the basis has only a small number of atoms but in a few instances, the basis exceeds 1000 atoms. For example, the basis in iodine crystal is 12 molecule whereas in the ice crystal,  $\text{H}_2\text{O}$  molecule is the basis.

### 3.2.3 Unit Cell

*The unit cell is the fundamental unit in a crystal.* The repetitive arrangement of unit cells in three dimensions produces a crystal just as a wall is built from identical bricks. In other words, a unit cell is the smallest unit of a crystal that on translational displacement in three dimensions will produce the crystal.

A unit cell chosen to represent the crystal may be quite different in size and shape from another unit cell that may be, it should be the simplest representation and, when repeated in three dimensions, it should produce the crystal.



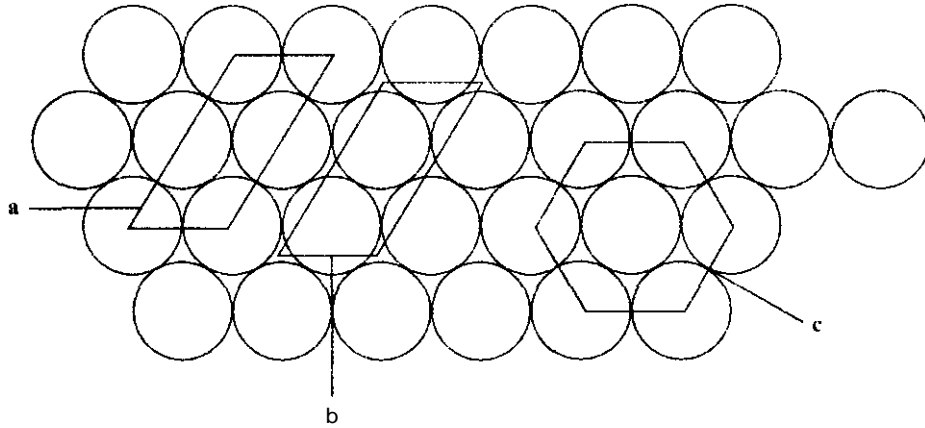
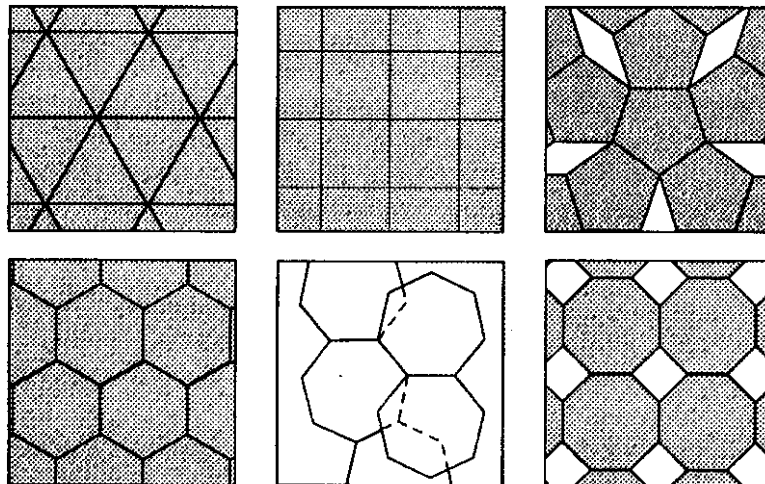

**Fig. 1.2:** Choice of unit cell

Fig. 1.2 shows four rows of spheres, representing atoms, in a closely packed structure in two dimensions. If we join the centres or any other points, say, gaps between the spheres, of different atoms in successive three rows, we get a cell of the type a, b or c. All the other rows of atoms are a repetition of the first three rows. It is immaterial whether the unit cell chosen is a, b, or c, but it is the simplest representation which on repetition in two dimensions will produce the entire assembly as shown in Fig. 1.2. The situation in a crystal is three dimensional. Thus, we can say that the simplest repeating unit in a crystal is called a *unit cell*.

It is true that the unit cell must have some regularity in structure. Does any type of regular shape constitute a unit cell? The answer is no. To understand this, let us consider the covering of a floor space by tiles without leaving a gap. Can we use any type of tiles—triangular, square, pentagonal, hexagonal, or octagonal? Again the answer is no. You can cover the floor space completely with triangular, square or hexagonal tiles but not with pentagonal, heptagonal or octagonal tiles are used.

Just as tiles with specific shapes are useful in covering the floor space completely, unit cells with specific symmetry properties constitute the crystal lattice. The course on Spectroscopy deals with symmetry properties in detail.



**Fig. 1.3:** Of all the regular polygons, only triangles, squares and hexagons can fill a floor space without a gap. Filled-in space is denoted by grey area

### Exercise 1

List out 5 examples of crystals and 5 examples of amorphous substances.

### Exercises 2

What is the essential characteristic of a unit cell?

## 3.3 Bravais Lattices and Crystal Systems

The basic shape of a unit cell is described by a parallelepiped (Fig. 1.4.a).

A unit cell has three co-ordinate axes,  $a$ ,  $b$  and  $c$  (note the bold letters). The cell-edge lengths in the three axes are  $a$ ,  $b$  and  $c$  (note the italicized letters), respectively (Fig. 1.4b). The angles between  $a$  and  $b$  axes,  $b$  and  $c$  axes and  $c$  and  $a$  axes are  $\gamma$ ,  $\alpha$  and  $\beta$ , respectively. The quantities  $a$ ,  $b$  and  $c$  are called lattice parameters or unit cell parameters.

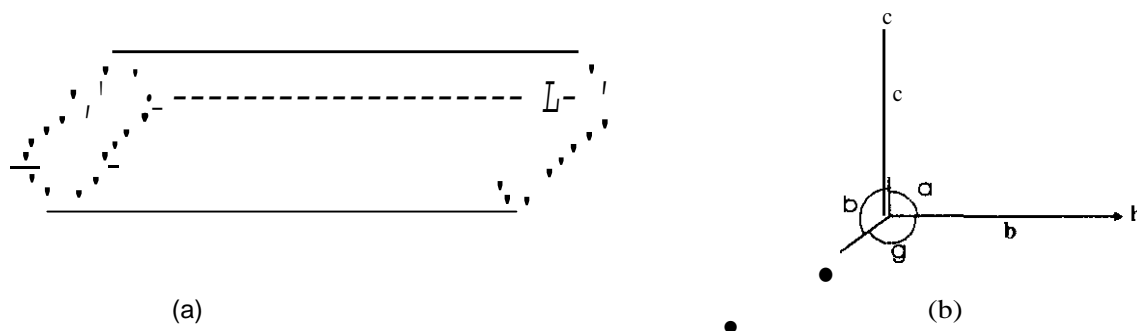

Fig. 1.4: (a) parallelepiped; (b) three co-ordinates, cell-edge lengths and the angles between axes

Based on the relationships among the axis angles and the edge-lengths, there are seven crystal systems as given in Table 1.1.

Table 1.1: The Seven Crystal Systems

Systems	Axes	Angles	Examples
Cubic	$a=b=c$	$\alpha = \beta = \gamma = 90^\circ$	NaCl, CsCl
Tetragonal	$a=b \neq c$	$\alpha = \beta = \gamma = 90^\circ$	TiO <sub>2</sub> (rutile)
Orthorhombic	$a \neq b \neq c$	$\alpha = \beta = \gamma = 90^\circ$	CdSO <sub>4</sub> , HgBr <sub>2</sub>
Rhombohedral	$a=b=c$	$\alpha = \beta = \gamma \neq 90^\circ$	CaCO <sub>3</sub> (calcite)
Hexagonal	$a=b \neq c$	$\alpha = \beta = 120^\circ, \gamma = 90^\circ$	SiO <sub>2</sub>
Monoclinic	$a \neq b \neq c$	$\alpha = \beta = \gamma \neq 90^\circ$	KIO <sub>3</sub> , NaHCO <sub>3</sub>
Triclinic	$a \neq b \neq c$	$\alpha \neq \beta \neq \gamma \neq 90^\circ$	NaHSO <sub>4</sub> , CuF <sub>2</sub>

### 3.3. Cubic System Geometry

Of the seven systems, we are particularly interested in cubic system due to its simplicity and symmetry. A cube has the same value for all the three lattice parameters ( $a=b=c$ ). We must understand the geometry of a cube. For this purpose, imagine that you are sitting in a cubical room. Each wall (including floor and ceiling) of your room is called a face. A cubical room has six faces- four walls, the ceiling and the floor. You can consider the ceiling and the floor as horizontal walls'

Each face has four corners. By joining the corners of a face diagonally, 1\vo face diagonals are obtained. For example, in Fig. 1.5b, the lines AC and BD (obtained by joining A and C, B and D respectively) are two of the twelve face diagonals in a cube. The centre point of a face where the two face diagonals meet is called a face-centre: one of the six face-centres is indicated by M in Fig 1.5b

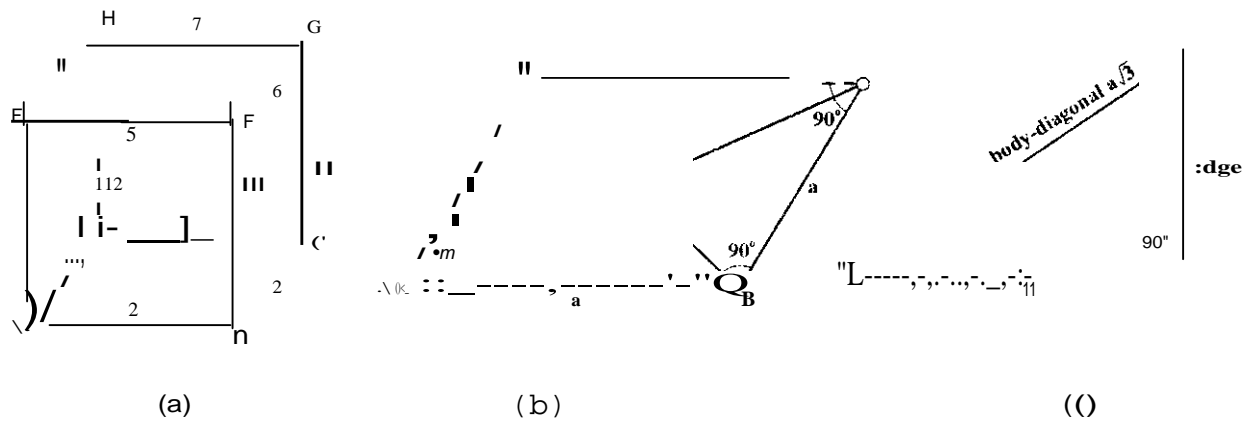

Fig. 1.5: (a) Flight lines in a cube indicated by letters A to H - each corner is marked by dots: Edges are indicated by number 1 to 12; (b) bottom face ABCD of the cube shown. AC and BD are the face diagonals and M is face-centre; (c) The right angled triangle MCG

Joining any two corners which are not in the same face, a body diagonal is obtained. There are four body diagonals in a cube - AG, BH, FD and EC in Fig. 1.5a. All the body diagonals meet at the body-centre. The definitions of face, corner, edge, face-centre and body-centre apply to other crystal systems, also

### 3.3.2 Bravais Lattice

Some crystal systems may be one or more types of lattices depending on the number of lattice points. If there are lattice points only at the eight corners of a lattice of a unit cell it is called a simple or primitive (P) cell. A cell that has eight lattice points at the corners and two more at the centres of a pair of any two opposite faces is called an end-centred (C) cell. If a cell has eight lattice points at the corners and one at the body centre, it is called a body centred (I) cell. The unit cells of the type P, C and I are called non-primitive cells. Based on the presence of lattice points in the seven crystal systems there are fourteen Bravais lattices: these are given in Fig. 1.6.

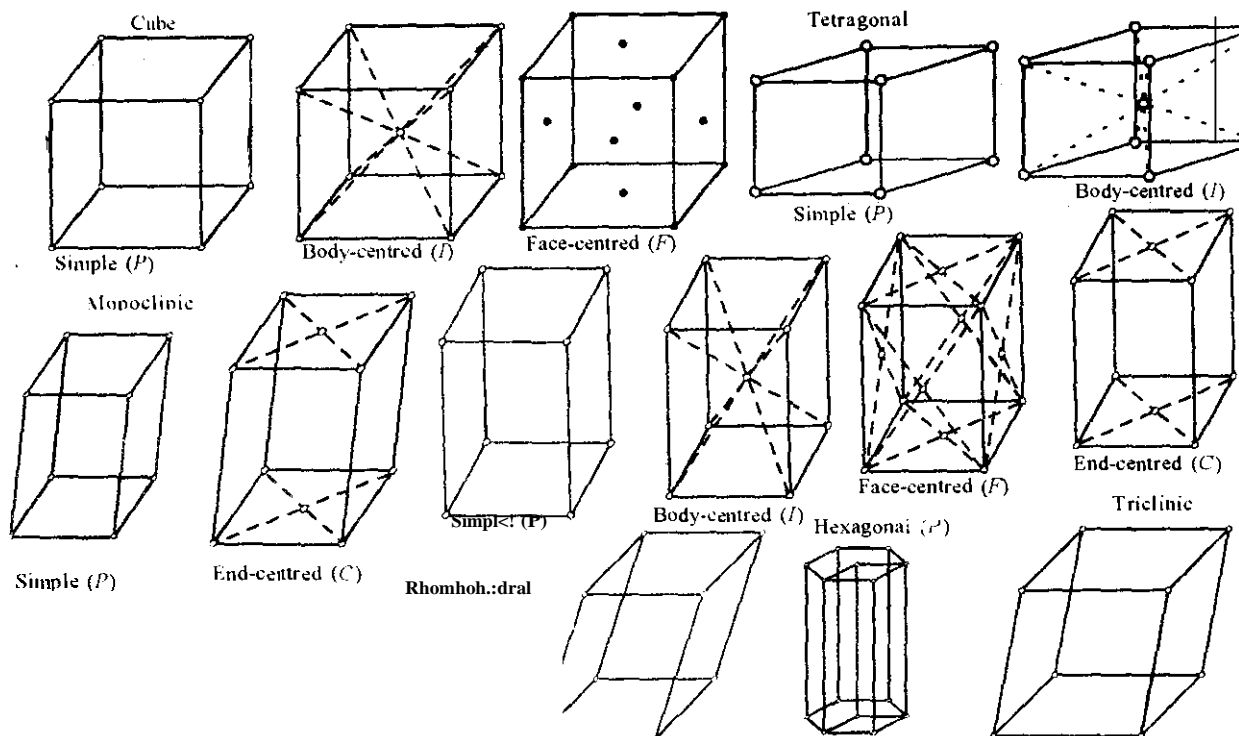

Fig. 1.6: Fourteen Bravais Lattices

Of these Bravais lattices, we shall consider simple cubic (Sc), body-centred cubic (bcc) and face-centred cubic (fcc) lattices only. In the next section, let us see how to represent the crystal planes.

### Exercise 3

Describe the following: simple cubic, body-centred cubic and face-centred cubic crystals.

## 4.0 Conclusion

In this Unit, we have briefly discussed those solid substances which can be classified as crystals. The crystalline solids are compared with other types. In addition, we have been able to explain some basic terms such as lattice, basis and unit cell. In all seven crystal systems and 14 Bravais lattices were discussed.

## 5.0 Summary

At the end of this Unit, you have learnt that:

- There are two main solid types - crystalline and amorphous.
- A crystalline solid consists of regular repetition of identical building blocks called crystals.
- A crystalline solid has definite melting point, a crystal lattice and definite heat of fusion.

- The unit cell is the fundamental unit in a crystal and its repetitive arrangement in a crystal is 3-dimensional.
- There are seven systems. Among them are cubic, tetragonal and hexagonal crystal systems.

## 6.0 References and Other Resources

Goldberg, David E and Diliard C. R. (1977) College Chemistry 3rd Revised Edition New York Macmillan Publishing Co. Ltd.

IGNOU (1997). States of Matter: Physical Chemistry CHE 04 New Delhi.

## 7.0 Tutor-Marked Assignment

1. In the following case, mark 'v' for correct statement and 'x' for wrong statement.
  - (i) The basis in ice crystal is H<sub>2</sub>O molecule.
  - (ii) A cube has twelve edges.
  - (iii) The unit cell of caesium chloride crystal contains the formula units of CsCl.
2. How many net atoms are there in a fcc and bcc unit cell?

## UNIT 2: Nature of Bonds in Solids

### Table of Contents

	<b>Page</b>
1.0 Introduction	82
2.0 Objectives	82
3.1 Crystal planes and Miller Indices	82
3.2 Determination of Unit Cell	84
3.2.1 Number of Net Atoms in a Cubic <b>Unit Cell</b>	84
3.2.2 Density Calculation	85
3.2.3 Experimental Method	85
3.3 Nature of Bonds in Solids	86
40 Conclusion	87
5.0 Summary	87
60 References and Other Resources	87
70 Tutor-Marked Assignment	87

## 1.0 Introduction

In Module 3, Unit I, we considered solid types. Both the crystals and the amorphous were mentioned. Though the study of amorphous substances is also quite useful and interesting, we shall confine ourselves to the study of the crystalline solids in this Unit and the next. Different crystalline structures are associated with different physical properties. Hence, we shall discuss the crystal forms and crystal structure determination method in this Unit.

## 2.0 Objectives

By the end of this Unit, you should be able to

- State the crystal planes in terms of Miller indices
- State explicitly Bragg law
- Describe correctly the determination of crystal structure by X-ray diffraction method
- Determine the type of unit cell based on experimental and calculated values of density
- Examine all the types of bonds in solids

## 3.1 Crystal Planes and Miller Indices

Crystal planes are represented by certain numbers which is known as Miller indices. These indices are determined in the following ways:

- Find the intercepts of a crystal plane on the axes, i.e. a, b and c in terms of cell-edge lengths a, b and c. Suppose that a crystal plane makes intercepts  $3a$ ,  $2b$ ,  $2c$  as shown in Fig. 2.1.

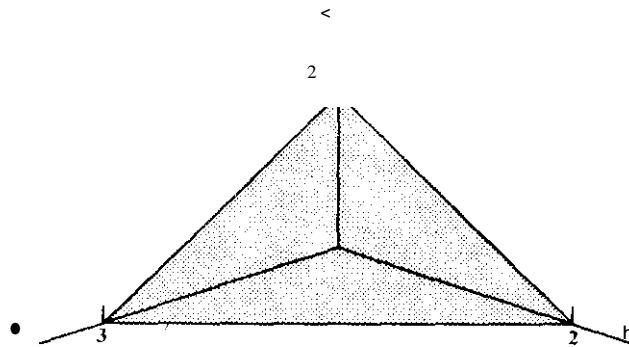

**Fig. 2.1:** Miller indices

- Divide the intercepts by the respective cell-edge lengths (a, b and c). For the crystal plane in Fig. 2.1, this step gives  $3a/a$ ,  $2b/b$ ,  $2c/c$ , i.e.  $3, 2, 2$  as the answer.
- Take the reciprocal of the above numbers. Corresponding to Fig. 2.1, this step gives  $1/3$ ,  $1/2$ ,  $1/2$  as the answer.
- Finally reduce the above fractions to the smallest integers having the same ratio. Write these numbers enclosed in parentheses without comma signs; these are the Miller indices of the given crystal plane. For the illustration in Fig. 2.1, the Miller indices are  $(233)$ : this is to be pronounced as *two three three plane*.

Miller indices are generally represented as  $(hkl)$ . You will notice that the Miller indices are defined in such a way that all equivalent and parallel planes are represented by the same set of Miller indices. Thus, planes whose intercepts are  $3a, 2b, 2c$  or  $a, 2b/3, 2c/3$  or  $9a, 6b, 6c$ , etc., are all represented by a set of Miller indices  $(233)$ .

If a face is parallel to an axis, theoretically the corresponding intercept is equal to  $\infty$ . To illustrate this, let us draw a crystal plane of a cubic cell which makes intercepts  $a, \infty, \infty$ . That is the plane is parallel to  $b$  and  $c$  axes. Applying the above steps in order, we get the Miller indices for this plane as  $(100)$ . Remember  $1/\infty$  is equal to zero. The origin (O) and the axes directions are shown in Fig. 2.2a. The  $(100)$  plane is indicated in Fig. 2.2b. Similarly, corresponding to the planes with intercepts  $a, a, \infty$  and  $a, a, a$ , the Miller indices are  $(110)$  and  $(111)$ , respectively; these are shown in Figs. 2.2c and d, respectively.

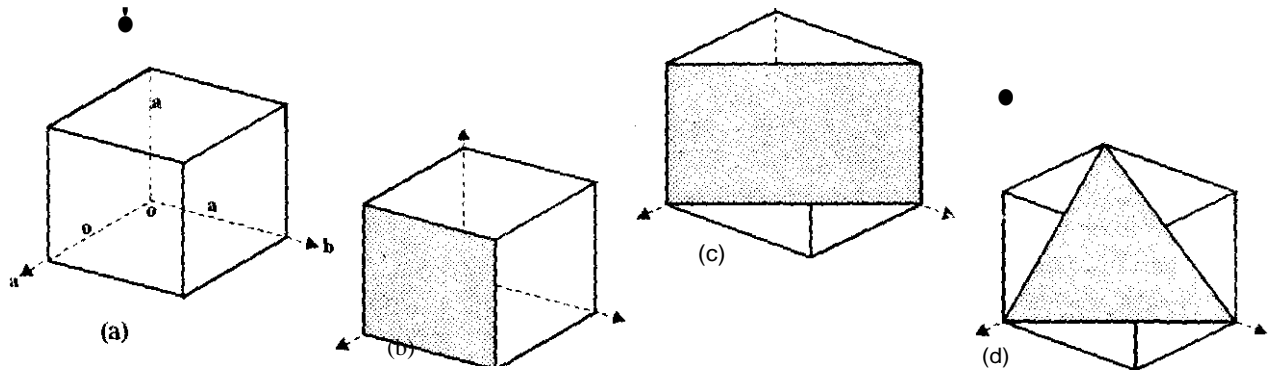

Fig. 2.2: (a) the origin, O the axes and the cell-edge length  $a$  in a cubic cell; (b)  $(100)$  plane; (c)  $(110)$  plane; (d)  $(111)$  plane

We can calculate the distance between the adjacent planes labelled by the same Miller indices  $(hkl)$ , but no generalized formula can be written. The actual formula in a particular case would depend upon the crystal structure. For example, the distance,  $d$ , between the  $(hkl)$  planes of a cubic lattice is given by

$$d = \frac{a}{\sqrt{h^2 + k^2 + l^2}} \quad \dots \dots \dots 3.1$$

where  $a$  is the cell-edge length of the cell and  $(hkl)$  are the Miller indices. Thus, in sodium chloride crystal the cell-edge length is  $5.63 \times 10^{-10}$  m. The distance between  $(111)$  planes is given by Eq. 3.1.

$$d_{111} = \frac{5.63 \times 10^{-10} \text{ m}}{\sqrt{1^2 + 1^2 + 1^2}} = \frac{5.63 \times 10^{-10}}{\sqrt{3}} = 3.25 \times 10^{-11} \text{ m}$$

Eq. 3.1 could be used only for cubic crystals. For an orthorhombic cell, the equation for  $d$  turns out to be

$$\frac{1}{d^2} = \left(\frac{h}{a}\right)^2 + \left(\frac{k}{b}\right)^2 + \left(\frac{l}{c}\right)^2 \quad \dots \dots 3.2$$

Using Eq. 3.2, work out the following exercise.

**Exercise 1**

An orthorhombic crystal has the following parameters:  
 $a = 8.2 \times 10^{-10}$  m;  $b = 9.4 \times 10^{-10}$  m;  $c = 7.5 \times 10^{-10}$  m



What is the distance between (123) planes.'

### 3.2 Determination of Unit Cell

The comparison between the experimental and the theoretical values of density could help us in determining the cubic cell type. First let us calculate the number of atoms belonging to a unit cell in each type of cubic cell.

#### 3.2.1 Number of Net Atoms in a Cubic Unit Cell

An atom at the body center of a unit cell belongs to that cell only. (Fig. 2.3a). An atom on the face-centre of a unit cell is shared by two unit cells (Fig. 2.2b) and thus, only half of such an atom belongs to one unit cell. An atom at the edge-centre of a unit cell is shared by four unit cells (Fig. 2.2c); one-fourth of an atom in the edge-centre belongs to one unit cell. But an atom at the corner of a unit cell will be shared by eight unit cells, as shown in (Fig. 2.2d). Hence, we can say that one eighth of an atom in a corner belongs to a particular unit cell. Using this background, let us calculate the number of net atoms present per unit cell for a simple cubic, face-centred cubic or body-centred cubic structure.

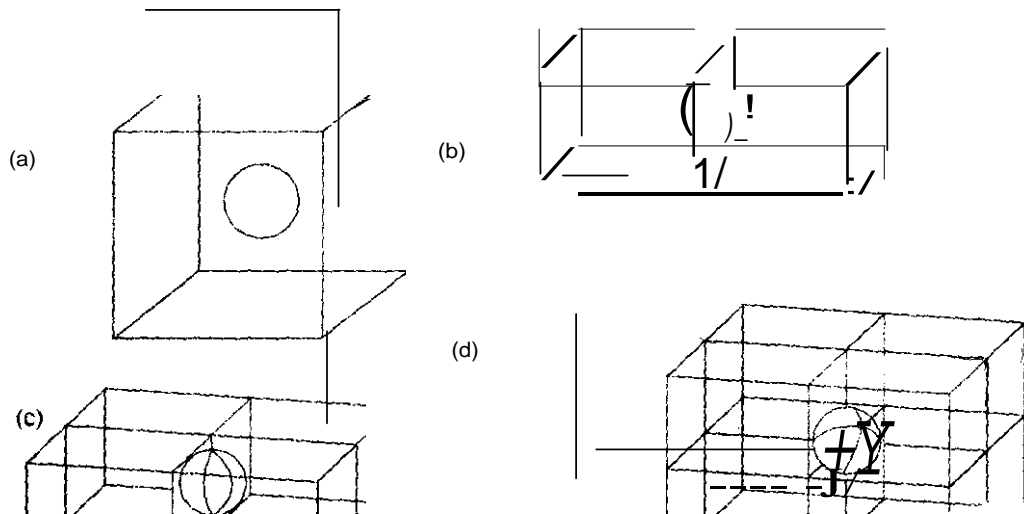

Fig. 2.3: (a) An atom at the body-centre of a unit cell; (b) An atom at the face-centre shared by two unit cells; (c) an atom at the edge-centre shared by four unit cells; (d) An atom in the corner shared by eight unit cells.

- In a simple cubic cell, there are atoms only at the eight corners; and hence, a simple cubic structure has only one net atom ( $8 \times 1/8 = 1$ ) per unit cell.
- On the other hand, in a bcc structure, there are atoms in the eight corners and the centre of the cell; hence there are two net atoms ( $8 \times 1/8 + 1 = 2$ ) per unit cell of a bcc structure.
- Finally, for a fcc structure, there are atoms at the eight corners and six face centres. That is, a fcc structure has four net atoms ( $(8 \times 1/8) + (6 \times 1/2) = 1 + 3 = 4$ ) per unit cell.

The density of a crystal depends on the number of atoms, their mass and the volume of the unit cell. Let us now see the calculation of the densities of these three types of unit cells.

### 3.2.2 Density Calculation

It is known that density = mass/volume .....33

X-ray measurements give us the cell-edge length. If the cell-edge length is  $a$  m, (i.e. a metre) then the volume of the unit cell =  $a^3 \text{ m}^3$  .....3.4

The mass of an atom of the substance is obtained by dividing the mass of one mole atoms (i.e. atomic mass ( $w$ ) in  $\text{kg mol}^{-1}$ ) by Avogadro's constant ( $N_A$  which is equal to  $6.022 \times 10^{23} \text{ mol}^{-1}$ )

$$\text{Mass of an atom} = \frac{w \text{ kg mol}^{-1}}{N_A \text{ mol}^{-1}} = \frac{w}{N_A} \text{ kg} \quad \text{.....3.5}$$

A simple cubic structure has only one atom per unit cell: hence, mass of unit cell of a simple cubic crystal is given by Eq. 3.5. Substituting the proper values from Eqs. 3.4 and 3.5 in Eq. 3.3, we get.

$$\text{The density of a simple cubic cell} = \frac{w}{N_A} \frac{1}{a^3} \text{ kg m}^{-3} \quad \text{.....3.6}$$

Since, simple cubic, bcc and fcc unit cells have one, two and four atoms per unit cell the densities of bcc and fcc are given by:

$$\text{Density of a bcc cell} = \frac{2w}{N_A a^3} \text{ kg m}^{-3} \quad \text{.....3.7}$$

$$\text{Density of a fcc cell} = \frac{4w}{N_A a^3} \text{ kg m}^{-3} \quad \text{.....3.8}$$

$$\text{In general, the density of a cubic unit cell } (\rho) = \frac{n w}{N_A a^3} \text{ kg m}^{-3} \quad \text{.....3.9}$$

where  $n$  is the number of net atoms per unit cell.

Re-arranging Eq. 3.9, we get

$$n = \frac{\rho N_A a^3}{w} \quad \text{.....3.10}$$

### 3.2.3 Experimental Method

The cell-edge length ( $a$ ) and the density ( $\rho$ ) of a crystal are experimentally determined. These values are substituted in Eq. 3.10 and  $n$  is calculated. Depending on whether  $n = 1$  or 2 or 4, the unit cells are simple cubic or bcc or fcc. Let us work out an example.

#### Example 1

Nickel metal packs in a cubic unit cell with a cell-edge length ( $a$ ) of  $352.4 \times 10^{-12} \text{ m}$ . The density ( $\rho$ ) of nickel is  $8.90 \times 10^3 \text{ kg m}^{-3}$ . Let us find out the unit cell type for nickel. Since atomic mass of nickel is  $58.7$ ,  $w = 0.0587 \text{ kg mol}^{-1}$ .

First we have to calculate  $n$  using Eq.3.10

$$n = \frac{\rho N_A a^3}{w}$$

$$n = \frac{8.90 \times 10^3 \text{ kg m}^{-3} \times 6.022 \times 10^{23} \text{ mol}^{-1} \times (352.4 \times 10^{-12} \text{ m})^3}{0.0587 \text{ kg mol}^{-1}}$$

4 (rounded to the nearest whole number).

Since there are four atoms per unit cell nickel has a fcc lattice.

In the following sections, we shall study the nature of bonds responsible for holding the solid together. Before that, attempt the following exercise:

### Exercise 2

Tungsten forms bcc crystals. Its cell-edge length is  $3.16 \times 10^{-10}$  m. Find the density of tungsten.

## 3.3 Nature of Bonds in Solids

There are basically two theoretical models to explain the nature of bonds in solids. One is known as *bond model* and the other as *band model*. These two names may sound new; however, they are the same two approaches that we have already studied (in Module I, Unit 4 and Module 2, Unit 2 of atoms and molecules course) in connection with the formulation of a molecule by the combination of two or more atoms. The bond model is the same as the *valence bond* approach.

Here, we consider a crystal as a three-dimensional arrangement of atoms and each of these atoms has valence electrons which can form normal chemical bonds with neighbouring atoms. These bonds may be ionic, covalent or Van der Waals in character. In the other approach, which is called the band model, we follow the molecular orbital treatment. All the nuclei with their core electrons are considered as a fixed periodic array or the skeleton of the crystal. It is like pouring of electron cement over a fixed arrangement of nuclear bricks. We have already read about ionic, covalent bond, hydrogen bond, etc. in Module I, Unit 3 of Atoms and Molecules course. We shall now study metallic bonding in terms of the above two models.

### Metallic Bonding

According to the bond theory, the metallic solids can be considered as having covalent bonds between adjacent atoms. However, the number of electron pairs available for bond formation is less than the number of orbitals available. Hence, when such substances are placed under an applied electric field, the electrons from the filled orbitals can easily flow into the vacant orbitals, thus making them highly conductive.

In the band theory of metals, a metallic solid is considered as a single giant molecule. The combination of atomic orbitals on all the atoms is taken to give molecular orbitals of the solid just as in the case of simple diatomic molecule. It is also assumed that there is negligible overlap of inner shell atomic orbitals and the energies of these remain practically the same as atomic orbitals on isolated atoms. However, the outer orbitals do combine to give molecular orbitals of bonding and antibonding character. Suppose that a crystal of sodium contains  $N$  atoms, where  $N$  is of the order of  $10^{23}$ . Neglecting the inner orbitals, there are  $N$  number of 3s orbitals on all the atoms in the crystal which can combine to give  $N$  molecular orbitals or delocalised crystal orbitals. Since each molecular orbital can hold 2 electrons, the total number of electrons which these orbitals can hold is  $2N$ . The total number of electrons is however  $N$ , since each atom is contributing only one 3s electron. Hence, only half of the molecular orbitals will be occupied by the electrons and half will remain vacant. Further, since there are many vacant orbitals and the total energy difference between the highest and the lowest orbital is very small, the energy separation between the adjacent molecular orbitals would be very small. For all practical purposes, we can consider these molecular orbitals as forming a continuous band of energy levels. Thus, we have a situation

where a band of vacant energy levels lie very near a band of occupied energy levels. Therefore, the electrons present in the occupied lower energy levels can easily move out to vacant band. This is the reason given for metals being good conductors of electricity.

### Exercise 3

The density of potassium bromide is  $2.826 \times 10^3 \text{ kg m}^{-3}$ . Its cell edge-length is  $6.54 \times 10^{-10} \text{ m}$ . It has a cubic structure. Find out whether it has CsCl or NaCl type of structure.

## 4.0 Conclusion

In this Unit, we have discussed crystal planes and Miller indices. We have compared the experimental and theoretical values of density that could help us in determining the cubic cell type. Example was worked out to enable you grasp the problem-solving skills in this area. Though, you may have to recall your knowledge on bonding from the Atoms and Molecules course, we treated in this Unit, the nature of bonds in solids specifically metallic bonding.

## 5.0 Summary

At the end of this Unit, you have learnt that

- Miller indices are certain number that represent crystal planes and are generally represented by (hkl)
- An atom on the face-centre of a unit cell is shared by 1/2 unit cells and only half of such an atom belongs to one unit cell.
- The density of a crystal depends on the number of atoms, their mass and the volume of the unit cell.
- Bond and band models explain the nature of bonds in crystals.

## 6.0 References and Other Resources

IGNOU (1997) States of Matter Physical Chemistry CHE-04 New Delhi

## 7.0 Tutor-Marked Assignment

1. What are the separation of the planes with Miller indices (111), (211) and (100) in a cubic crystal having cell-edge length of  $432 \text{ pm}$ ?
2. Sodium crystallizes in a bcc lattice with a cell-edge length of  $4.23 \times 10^{-10} \text{ m}$ . Calculate the density of sodium metal.
3. The density and cell-edge length of sodium chloride are  $2.163 \times 10^3 \text{ kg m}^{-3}$  and  $5.63 \times 10^{-10} \text{ m}$ , respectively. Using these data, arrive at the number of formula units per unit cell of sodium chloride crystal.

## Unit 3: Structures of Crystals

### Table of Contents

	<b>Page</b>
1.0 Introduction	X0
2.0 Objectives	
3.1 Crystals	XY
3.1.1 Ionic Crystals	
3.1.2 Covalent Crystals	Y0
3.1.3 Molecular Crystals	Y1
3.2 Commonly Encountered Metallic Structures	Y1
<b>3.3 Semiconductors</b>	<b>Y2</b>
3.3.1 Intrinsic Semiconductors	Y2
Extrinsic Semiconductors	
4.0 Conclusion	Y3
5.0 Summary	
6.0 References and Other Resources	<b>93</b>
7.0 Tutor-Marked Assignment	

## 1.0 Introduction

It is correct to say that the information obtained from crystal structure studies could help us in understanding better the physical and chemical properties of solids. In Module 3. Unit 2. we discussed the nature of bonds in different solid types. In this Unit. we shall examine the ionic, covalent and molecular structures of crystals. In addition. the chemistry of semiconductors with particular reference to electrical conduction is described.

## 2.0 Objectives

By the end of this Unit, you should be able to:

- State all the crystals in solids.
- Discuss the structures of some ionic, covalent and metallic crystals.
- Describe all the types of semiconductors.

## 3.1 Crystals

There are several types of solid crystals. In this section, we shall consider the structures of some of them, which have either ionic or covalent bonds; examples are also given for crystals having covalent bonding with Vander Waals attraction or hydrogen bonding.

### 3.1.1 Ionic Crystals

As examples for ionic crystals. we shall consider caesium chloride and sodium chloride which have bcc and fcc structures. respectively.

#### Bcc Structure

The structure of a bcc crystal can be defined in terms of unit cell-edge length and two unique positions in the cell. Consider a crystal like CsCl which has bcc structure and has two different ions in lattice positions. Suppose the centre of a cube is occupied by Cs<sup>+</sup> ion; then, this is one of the unique positions of the crystal. It is unique because there is no other point within the cell which is one cell-edge length away and which can be occupied by another Cs<sup>+</sup> ion. Now, if one of the corners of the cube is occupied by a chloride ion, then all the eight corners of the cube must be occupied by chloride ions. This is so because each of the corners is one unit cell-edge length away from its nearest neighbours and if one corner is occupied by Cl<sup>-</sup> ion, its immediate neighbours which are unit cell-edge length away must also be occupied by chloride ions. We can say that any one corner position is unique in the sense that once you associate an atom with this position, then all the other corners automatically get associated with the similar atoms. Thus, once these two positions are defined the whole crystal gets defined (Fig. 3.1)

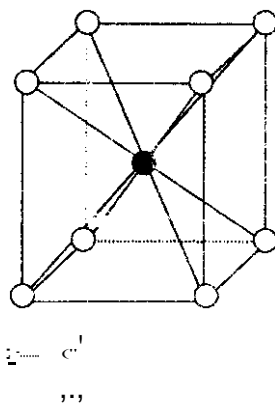

Fig. 3.1: CsCl structure

Since CsCl crystal has one Cs<sup>+</sup> ion at the centre and eight Cl<sup>-</sup> ions at the corners, it has one Cs<sup>+</sup> ion and one Cl<sup>-</sup> ion ( $8 \times \frac{1}{8} = 1$ ) belonging to one unit cell as per discussion in Subsection 3.2.1 of the last unit. That is, each CsCl unit cell has one formula unit.

### Fcc Structure

In a fcc structure, there are four unique positions: once these positions are defined, the rest of the crystal gets completely described. These are the centres of three adjacent faces and one corner. Once, one corner is occupied by an atom, all other corners will have similar atoms. Further, if one atom occupies the centre of one face, the centre of the opposite face would also be occupied by similar atom. Thus by describing the atoms which occupy the centres of adjacent three faces, we know the atoms occupying the centres of all the six faces. Similarly, all the eight corners are described, once we know the atom occupying one of the corner positions. Thus, the whole crystal is described. Sodium chloride is one example. It can be considered to be composed of two interpenetrating fcc lattices, one made up of sodium ions and the other made up of chloride ions (Fig 3.2.)

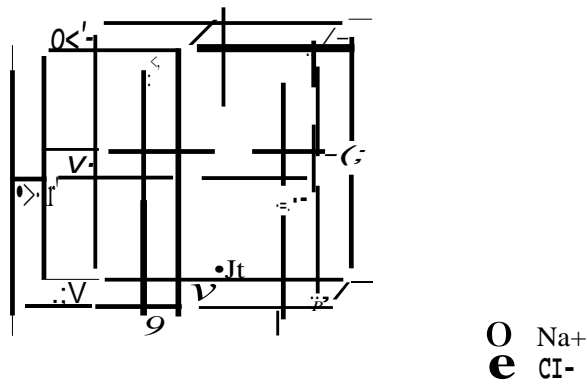

Fig 3.2: Structure of sodium chloride

The sodium ion lattice is shifted in all the three dimensions by half-cell edge length from the chloride ion lattice. A unit cell of NaCl contains four formula units.

### 3.1.2 Covalent Crystals

In covalent crystals, definite covalent bonds join all the atoms in the crystal. The structure of a covalent crystal is related to the number of valence electrons, the nature of orbital involved in bond formation and their orientation. One of the most commonly cited examples is that of diamond (Fig. 3.3). Each carbon atom in diamond is tetrahedrally bonded to four neighbouring carbon atoms. This is so since carbon has four  $sp^3$  hybridised orbitals pointing towards the corners of a regular tetrahedron. These orbitals overlap with the similar set of orbitals on the neighbouring atoms. Crystals thus formed are hard and unreactive.

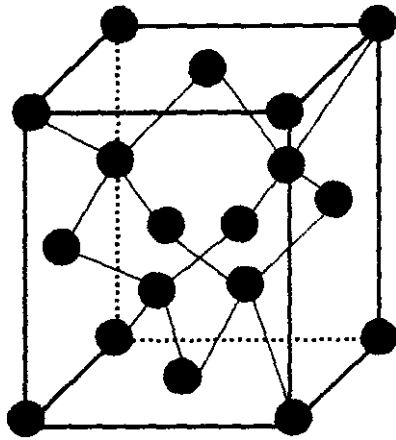

Fig. 3.3: Structure of diamond

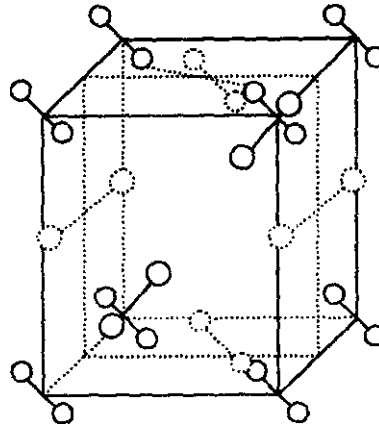

Fig. 3.4: Structure of iodine crystal the basis is I<sub>2</sub> molecule

Let us now see another type of covalent crystals known as molecular crystals.

### 3.1.3 Molecular Crystals

In molecular crystals, the molecules are held together due to Van der Waals interaction. These crystals acquire the structure which has the minimum energy maintaining the original shape of the discrete molecules. Iodine (Fig 3.4) and carbon (IV) oxide crystals are examples of this type.

There is a class of crystals which have hydrogen bonding between the molecules. An example of this type is ice. In ice, each oxygen atom is tetrahedrally surrounded by four hydrogen atoms, two being linked through covalent bonds in the same molecule and the other two through hydrogen bonds to different water molecules. In the next section, we shall illustrate the four main types of crystal structures in metals.

#### Exercise I

Classify the following crystal types:

- (a) CaF<sub>2</sub> (b) CH<sub>4</sub> (c) Cu (d) Ni (e) S<sub>8</sub>

## 3.2 Commonly Encountered Metallic Structures

Most of the metals crystallize in one of the four basic structures—simple cubic, body-centered cubic (bcc), hexagonal closed packed (hcp) and face-centered cubic (or cubic closed packed—ccp). Simple cubic structure is not very common except perhaps for polonium metal which packs in this structure. Alkali metals, Ba, V, Cr, Mo, etc., crystallize in bcc structure. The number of nearest neighbours (co-ordination number) is 8 in bcc arrangement.

Each atom in hcp and ccp arrangements touches three atoms in the plane above, three in the plane below and six in the same plane. Thus, in both cases, the co-ordination number is 12. Further, in ccp and hcp structures, 74% of the total space is filled with atoms. The difference between the hcp and ccp structures (Figs. 3.5a and b) is in the alignment of the third layer of atoms with respect to the



first layer. Metals like Be, Mg, Co, Zn, pack in the hcp structure, whereas those like Ag, Au, Cu, Ni crystallize in ccp arrangement.

### 3.3 Semiconductors

Semiconductors are solids which are insulators under normal conditions but become conductors when heated or doped with impurities. The electrical conductivity of a semiconductor increases with temperature. The semiconductors can be broadly classified into two types. Let us consider them one by one.

#### 3.3.1 Intrinsic Semiconductors

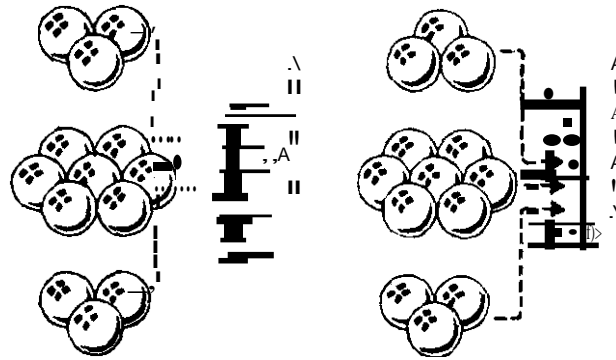

**Fig. 3.5:** (a) hcp arrangement - the atoms in the third layer are straight above those in the first layer called ABAB arrangement; (b) ccp arrangement - the atoms in the third layer arranged differently from those in the first, called ABCABC arrangement.

#### 3.3.2 Extrinsic Semiconductors

Semiconductors with impurities are called extrinsic semiconductors. They can be classified into n-type and p-type semiconductors.

##### n-type Semiconductors

When a semiconductor is doped with an impurity having more valence electrons than those in the semiconductor, an n-type semiconductor is produced. Such an impurity can donate electron(s) to the valence band of the semiconductor, and is called a *donor*. Phosphorus, arsenic or antimony (each having five valence electrons) are examples of donor impurities added to germanium or silicon (each semiconductor having four valence electrons). The addition of donor impurity to the semiconductor provides additional energy levels and if they are right-related to the bands of the semiconductor, conductivity may result. That is, if the impurity contains an energy level just below that of an empty band in the semiconductor, the electrons from the impurity go to the empty band in the semiconductor. Hence, it becomes negatively charged (n-type). Up to certain temperature, the conductivity of n-type semiconductor increases with increase in temperature.

##### p-type Semiconductors

When the impurity used for doping has less valence electrons than the semiconductors, the impurity can accept electron(s) from the valence band of the semiconductor. Such an impurity is called *acceptor*. The addition of boron, aluminum, gallium or indium (each having three valence electrons) to silicon or

germanium (each semiconductor having four valence electrons) is an example of this type. The essential feature is that the impurity must contain an empty energy level just above a full band in the semiconductor. The electrons from the full band in the semiconductor will pass to the empty level of the impurity; passage of electron from the semiconductor to impurity makes the former positively charged (P-type). The effect of temperature on the conductivity of a p-type semiconductor is similar to that of n-type semiconductor.

The combination of p-type and n-type semiconductor is called *p-n junction*. The p-n junctions are used as rectifiers, solar cells, light emitting diodes and other electronic devices.

#### Exercise 2

Differentiate between intrinsic and extrinsic semiconductors.

## 4.0 Conclusion

In this Unit, we have examined different crystal types. We focussed specifically on ionic, covalent and molecular crystals. The semiconductors were also discussed. The uses of two types of semiconductors were described. For the next Unit, we will be discussing liquids.

## 5.0 Summary

At the end of this Unit, you have learnt that

- Crystal solids can be classified into ionic, covalent, molecular and metallic.
- The ionic solids are body-centred cubic (bcc) and face-centred cubic (fcc).
- The molecules in molecular solids are held by Van der Waals interaction.
- Most metals have fcc, bcc and hcp lattices.
- Extrinsic semiconductors are insulators with impurities under normal conditions but their electrical conductivity increases with temperature.

## 6.0 References and Other Resources

IGNOU (1997). States of Matter: Physical Chemistry CHE -04 New Delhi.

## 7.0 Tutor-Marked Assignment

I. Identify the type of attractive forces (or bonding) mainly responsible for crystal bonding in the following cases:

- (i) diamond (ii) potassium bromide (iii) aluminium (iv) helium

These properties are related to the strength of intermolecular forces in liquids. We now discuss surface tension and viscosity of liquids.

### Surface tension

The presence of a surface in a liquid gives rise to the phenomenon of surface tension. Let's see how it arises. In the absence of external forces, liquids form spherical drops spontaneously. This is facilitated by the fact that for a given volume, a sphere has a smaller surface area than any other shape. This fascinating phenomenon is one of the reasons for the spherical shape of earth, sun, moon, etc. Let us explain the origin of forces operating to minimize surface area.

All the molecules surrounding it attract a molecule in the interior of a liquid. It is pulled equally in all directions. It is important to note that a molecule at the surface of a liquid is attracted only by molecules below it (Fig. 4.2)

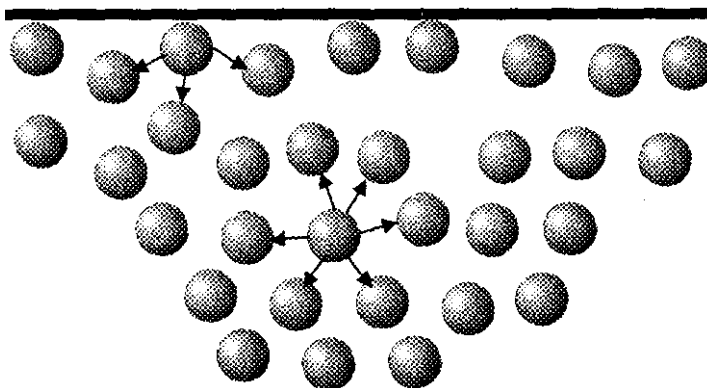

Fig 4.2: Molecules in the bulk and on the surface of liquid being attracted by neighbours

Therefore, the molecules on the surface of the liquid are drawn inwards trying to minimize the surface area. Because of this tendency of a surface to contract, each point on the surface of the liquid is under pressure like a stretched rubber membrane. The resistance of a liquid to increase its surface area is correlated to its surface tension. It is defined as the energy required for increasing the surface area by one unit by moving the molecules from the interior of the liquid to the surface. It is also defined as the force per unit length perpendicular to a liquid surface. Corresponding to these two definitions, SI units of surface tension are  $J m^{-2}$  and  $N m^{-1}$  (which are of course, equivalent). It is represented by the Greek letter  $\gamma$ . Increase of temperature increases the thermal motion of the molecules in a liquid. This opposes the effect of intermolecular forces. Thus as temperature is raised, the surface tension decreases.

The value of surface tension of some liquids are given in Table 4.1.

Table 4.1: Values of surface tension ( $\gamma$ ) of some liquids at 293 K

Liquid	$10^2 \times \gamma / N m^{-1}$
Water	7.28
Benzene	2.89
Carbon tetrachloride	2.64
Chloroform	2.67
Mercury	46.5

Some of the factors, which influence the magnitude of surface tension, are given below:

- Molecules having strong hydrogen-bonds have high surface tension. The surface tension of water, for example, is about three times higher than that of non-polar liquids like carbon tetrachloride.
- Metallic bonding also leads to high surface tension. For example, the surface tension of mercury is more than six times that of water.
- The dispersion forces are quite significant in molecules with large atoms and are often more important than dipole-dipole forces. In fact, surface tension of carbon tetrachloride is only slightly less than that of chloroform: the effect of London forces in the former is nearly equal to the combined effect of London and dipole-dipole forces in the latter.

Intermolecular forces give rise to capillary action. It is the rise of liquids through a capillary (narrow glass) tube (Fig. 4.3a). Two types of forces—cohesive and adhesive—are responsible for this property. The cohesive forces are the intermolecular forces among the molecules of a liquid that we discussed in Module 2, Unit I. Adhesive forces exist between the liquid molecules and the molecules in the capillary walls. For example, glass contains many oxygen atoms: each oxygen atom (with partial negative charge) attracts (the positive end of) a polar molecule, such as water.

The adhesive forces enable water to “wet” the glass. The adhesive forces acting upward pull up a water column inside a capillary tube when the latter is in contact with water. The height of the water column inside the capillary tube is such that the adhesive forces acting upwards balance the cohesive forces (in the form of weight of water column) acting downwards. The height of the water column inside the capillary tube has been found to be inversely proportional to the radius of the tube. Hence only in tubes of small radius, the capillary rise is meaningful.

The concave shape of the meniscus of water in a glass tube indicates that the adhesive forces of water towards the glass are stronger than its cohesive forces. A metallic liquid such as mercury (Fig. 4.3b) shows a lower level in a capillary tube and a convex meniscus. This behaviour is characteristic of a liquid in which the cohesive forces between its molecules are stronger than the adhesive forces between the molecules and glass.

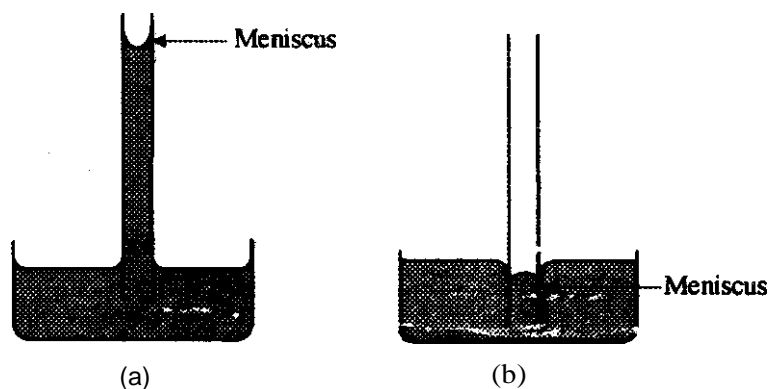

Fig. 4.3: (a): A polar liquid such as water rises in a capillary tube and has a concave meniscus in a glass tube. (b): A metallic liquid such as mercury shows a depression of level in a glass tube and has a convex meniscus.

### Viscosity

Another property of liquid that depends on intermolecular forces is viscosity; it is a measure of the resistance to flow. A liquid, which has higher viscosity, flows slowly. It is represented by the Greek letter  $\eta$  (eta). Its unit is Pas. It decreases with temperature. The viscosities of a few liquids are given in Table 4.2.

## 3.2 Comparison of Liquids with Gases and Solids

We can obtain a liquid by heating a solid or by cooling a gas under certain conditions. We also have it naturally. From your observations, interactions with the substances provided, what do you say about a liquid? Therefore, liquid state is in between solid and gaseous states. In a solid, the particles have only vibrational motion about their equilibrium positions. The strong intermolecular forces present in a solid crystal are responsible for the restricted motion of the particles and their orderly arrangement.

As a result, a solid has a definite shape. In contrast to this, the molecules in a gas are free to move randomly and have a disorderly arrangement. The gases can expand or contract to conform to the volume of the vessel. Hence, the gases have no definite shape or volume.

The characteristics of liquids lie between the extremes of a gas and a solid. The particles in a liquid are free to move from one point to another. In this respect, it resembles a gas. The ability of a liquid to flow enables it to assume the shape of its container. Yet it never expands or contracts to fill the container and thus resembles a solid. *Thus* now examine the structural aspects of liquids.

## 3.3 Structure of Liquids

The particles in a liquid are not as much orderly as in a solid; also not as much disorderly as in a gas. To establish this, we cite the following three pieces of evidence:

### 3.3.1 Volume Change During Fusion and Vaporization

A pure solid melts to give a liquid at a sharp temperature. Do you agree? Take an ice block for close examination. Observe it while melting in a beaker. This process is called fusion. It is generally seen that during fusion, volume increases by 10%. This implies that a substance retains its orderliness to a considerable extent during fusion. On the contrary, in the conversion of a liquid to vapour at its boiling point (known as vaporization), the volume increases 1000–10000 fold. This large increase in volume during vaporization indicates that the particles are changed into a more disorganized state.

### 3.3.2 Molar Enthalpies of Fusion and Vaporization

The amount of heat required at constant pressure to convert one mole of a solid into liquid at its melting point is called molar enthalpy of fusion ( $\Delta H_{\text{fus}}$ ). Similarly, the amount of heat required at constant pressure to convert one mole of a liquid into its vapour at its boiling point is called the molar enthalpy of vaporization ( $\Delta H_{\text{vap}}$ ). The values of  $\Delta H_{\text{fus}}$ ,  $\Delta H_{\text{vap}}$  and boiling point (BP) are given in Table 4.1 for some substances. It is seen that  $\Delta H_{\text{vap}}$  is larger than  $\Delta H_{\text{fus}}$  for all the substances. It requires more heat to convert a liquid into vapour than to convert a solid into liquid. It is reasonable to assume that a large heat absorption during change of state is associated with increase in disorder. On this assumption, we can think that a liquid has a considerable measure of orderly arrangement as compared to a gas.

### 3.3.3 X-ray Diffraction by Liquids

In your programme, you shall study that the X-ray diffraction by a solid crystal gives rise to sharp diffraction pattern. The sharpness of diffraction pattern is an indication of the orderly arrangement of atoms or ions in the crystal lattice. Gases, on the other hand, do not give rise to diffraction lines with X-rays. This is again due to the random arrangement and movement of molecules in a gas. Liquids do give diffraction patterns with X-rays; although the lines are diffuse (i.e. not quite sharp): The diffuse diffraction pattern makes it clear that the order in the arrangement of particles is only partial but not

total. Experimental data indicate that the first few neighbours of a particle in a liquid are at fairly well defined distances: the neighbours farther away are randomly distributed. This means that the arrangement of particles in a liquid exhibits short range order and long range disorder. The number of nearest neighbours around the particles in different regions of a liquid is not the same. A model of the structure of liquids is shown in Fig 4.1.

Fig. 4.1. A model for the structure of liquid. The particles are represented by small spheres. The spaces between the particles are labeled as 'Voids'.

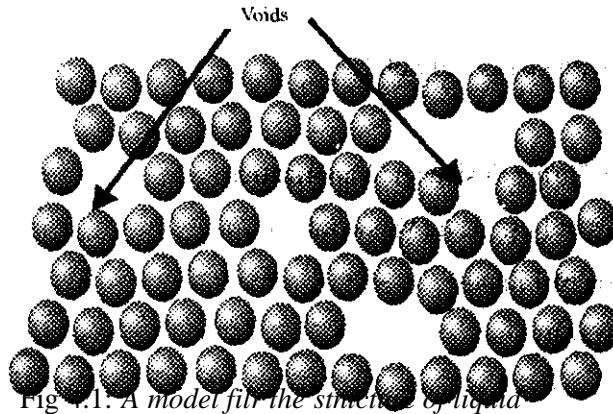

Fig. 4.1. A model for the structure of liquid.

The main aspects of this model are summarized below:

- The particles in a liquid are fairly close.
- These particles have higher kinetic energy (and hence, speed) compared to those in a solid.
- Because of their speed, the individual particles occupy more space, and a liquid is less dense than the corresponding solid.
- To explain the relative densities of liquids and solids, it is further assumed that there are some voids between the molecules.
- These voids enable the liquids to flow.
- Particles close to one of the voids behave like a particle in a gas.

Based on the above, answer the following exercise.

#### Exercise 1

Liquids are less compressible than gases. State the reason.

### 3.4 Surface Tension and Viscosity

Having discussed the structure of liquids, we now take up the study of the properties of liquids. Three of the characteristic properties of liquids are:

- Possession of a sharply defined surface
- Ability to flow
- Tendency to vaporize into space above the surface and to exert vapour pressure

## Umt 4 Liquids

### Table of Contents

	Page
1.0 Introduction	95
2.0 Objectives	95
3.1 Concept of a Liquid	
3.2 Comparison of Liquids with Gases and Solids	
3.3 <b>Structure of Liquids</b>	
3.3.1 Volume Change During Fusion and Vaporization	
3.3.2 Molar Enthalpies of Fusion and Vaporization	
3.3.3 X-ray Diffraction by Liquids	
3.4 Surface Tension and Viscosity	97
4.11 (UJH: In JOn	1111
So Summar	<b>101</b>
6.11 References and Other Resources	101
7.0 Tutor-Marked Assignment	<b>101</b>

## 1.0 Introduction

In Module 2, Unit 2, we discussed the characteristics of ideal gases. We assumed that there is no attractive or repulsive interaction between the individual molecules. In Module 2, Unit 5, this treatment was modified to account for the behaviour of real gases at low temperatures and high pressures and to explain the liquefaction of gases. Finite sizes of the gaseous molecules and their weak interaction were recognized. In Module 3, Units 1 and 2, we studied the strong interactions in a solid crystal and the order! arrangement of particles in it. In this Unit and in Unit 5 of this Module, we will discuss the characteristics of liquids in contrast to those of gases and solids. Our aim in this unit is not to list the properties of liquids but to correlate these to the intermolecular interactions.

We will describe the features of a model proposed for the structure of liquids. We shall explain the correlation between the intermolecular forces and the properties of liquids such as surface tension, viscosity, vapour pressure, boiling point and molar enthalpy of vaporization.

## 2.0 Objectives

By the end of this Unit, you should be able to

- Explain the concept of a liquid
- Compare distinctly liquids with gases and solids in Module 1
- Explain accurately the structure of liquids
- State the significance of surface tension and viscosity of liquids.

## 3.1 Concept of a Liquid

Milk, kerosene, petrol, water, salt solution, alcohol and sugar solution are all liquids. Mercury is even a heavy liquid. Why do we say these are all liquids despite the fact that:

- (i) They are different substances
- (ii) Some contain a mixture of solid and liquid substances
- (iii) Some are organic and some inorganic
- (iv) One of them is even metallic
- (v) Some are compounds while some are elements.

What then makes a liquid? There is no doubt you have interacted with each of the samples listed as liquids. Perhaps a close examination of these substances will enable you to have the right description of what a liquid is.

Activity I

Apparatus: Test tubes, balance, water, milk, kerosene, petrol, salt solution.

Procedure:

Weigh each of the 5 test tubes.

Collect 5cm<sup>3</sup> of each of the samples separately into the weighed five test tubes

Re-weigh each of the test tubes with content inside.

Determine the density of each liquid.

Shake the content in the test tubes.

Examine the surface of each liquid in the test tubes.



Table 4.2: Viscosity ( $\eta$ ) of some liquids at 298 K

Liquid	$\eta$ /Pa s
Water	$8.90 \times 10^{-4}$
Benzene	$6.0 \times 10^{-4}$
Glycerol	0.9945
Chloroform	$4.7 \times 10^{-4}$

Liquids with larger intermolecular forces flow slowly and are called viscous liquids. Hydrogen bonding is particularly important in this respect because it can bind neighbouring molecules together much strongly. This accounts for the fact that water has higher viscosity than benzene and chloroform, which have no hydrogen bonding. Glycerol has very high viscosity, mainly due to numerous bonds it can form.

Molecular arrangement also could cause high viscosity. Heavy hydrocarbon oils and grease are not hydrogen bonded but are highly viscous. Their viscosity arises partly from London forces between molecules and partly because the long chain-like molecules become entangled with each other (Fig 4.4) like cooked noodles served on a plate.



Fig. 4.4: The molecules in the heavy hydrocarbon oil entangled together

Use the above discussion on surface tension and viscosity to answer the following exercises.

#### Exercise 2

For waterproof coating of wood paraffin wax is used. Explain the reason. (Hint: paraffin wax is a mixture of solid hydrocarbons)

#### Exercise 3

Among the alkanes -octane ( $C_8H_{18}$ ), nonane ( $C_9H_{20}$ ) and decane ( $C_{10}H_{22}$ )- which is expected to have the highest viscosity?

## 4.0 Conclusion

In this Unit, we studied the characteristics of liquids. The model proposed for the structure of liquid was discussed. Surface tension and viscosity of liquids were explained and the dependence of these characteristics on intermolecular forces was brought out. We discussed the properties of liquids such as vapour pressure, molar enthalpy of vaporization and boiling points.

## 5.0 Summary

At the end of this Unit, you have learnt that:

- A liquid is a substance that flows and has no definite shape of its own.
- The characteristics of a liquid lie between the extremes of a gas and a solid.
- Three evidences of volume change during fusion and vaporization, molar enthalpies of fusion and vaporization and X-ray diffraction by liquids show that a liquid has considerable measure of orderly arrangement as compared to a gas.

## 6.0 References and Other Resources

IGNOU. (1997). States of Matter: Physical Chemistry CHE-04 New Delhi.

## 7.0 Tutor-Marked Assignment

- (1) Comment on the fact that the densities of solid, liquid and gaseous nitrogen are 1.026, 0.8081 and  $1.251 \times 10^{-3} \text{ kg cm}^{-3}$ , respectively.
- (2) In a polythene tube, water meniscus is convex. Explain.
- (3) Molar enthalpies of vaporization of benzene and naphthalene are 31.1 and 44 kJ mol<sup>-1</sup>. Explain.
- (4) At room temperature, among water, methyl cyanide and methanol, which is expected to have the highest tension? State the reason.
- (5) Why the viscosity of water at 373 K is one-sixth of its viscosity at 273 K?

## Unit 5 Other Properties of Liquids

### Table of Contents

	Pages
<b>III</b> Introduction	103
2.0 Objectives	103
<b>3.1</b> Vaporization	103
3.1.1 Vapour Pressure	103
3.1.2 Boiling Point	105
32 Trouton's Rule	106
3.3. Liquid Crystals	107
4.0 Conclusion	109
5.0 Summary	(((<
60 Tutor-Marked Assignment	109

## 1.0 Introduction

So far we have examined different samples of liquids. By now we should be able to explain what a liquid is irrespective of what it is made up of. In the preceding Unit, we discussed some characteristics of liquids. Specifically we described the structure of liquids among other properties. In this Unit, we will be discussing other properties of liquids including boiling point and liquid crystals, their types and applications.

## 2.0 Objectives

By the end of this Unit, you should be able to

- Discuss the qualitative dependence of vapour pressure, boiling point and molar enthalpy of vaporization of liquids on the molecular interactions.
- State and explain Trouton's Rule.
- Discuss all the types of liquid crystals and their applications.

## 3.1 Vaporization

The escape of molecules from the liquid surface to form vapour is called *vaporization* or *evaporation*. To have an understanding of this process, we must know how vapour pressure, boiling point and molar enthalpy of vaporization are connected among themselves and also to the intermolecular forces.

### 3.1.1 Vapour Pressure

The molecules in a liquid are constantly vibrating. If a molecule has sufficient kinetic energy, it can jump out into the space above the liquid as vapour. If the liquid is kept in an open vessel, the molecules escape into the atmosphere and the liquid keeps on evaporating. However, if the liquid is kept in a closed vessel, the number of molecules in a vapour state increases at first (Fig 5.1a). They also start returning to the liquid surface which is called condensation. The condensation rate keeps on changing till it is equal to the rate of vaporization and the space above the liquid is saturated with vapour (Fig 5.1b). The pressure exerted by a vapour in contact with its liquid at a given temperature is called its vapour pressure.

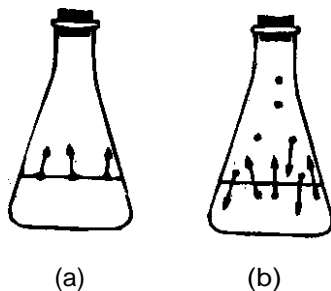

Fig 5.1: (a) Initially molecules are transferred from the liquid to the vapour phase:  
(b) at equilibrium, the rate of vaporization is equal to the rate of condensation

Vapour pressure of a liquid is commonly measured by introducing a liquid into a container, the container is closed and connected to a U-tube containing mercury (Fig. 5.2).

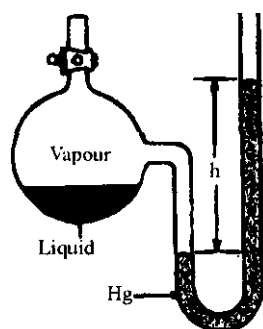

Fig. 5.2. Vapour pressure measurement

The difference in the heights of mercury columns (h) is measured in mm of Hg unit. The vapour pressure in SI units can be calculated using the following equivalence statement: 760mm of Hg  $1.013 \times 10^5$  Pa (Recapitulate the unit conversions discussed in Sec.3.5 of Unit 1 in Module I).

The vapour pressures of some liquids are given in Table 5.1.

Table 5.1: Vapour Pressure of some Liquids at 298 K

Substance	Vapour pressure/Pa
Mercury	0.227
Water	$3.17 \times 10^3$
Ethanol	$7.85 \times 10^3$
Diethyl ether	$5.90 \times 10^4$
Benzene	$1.26 \times 10^4$

From Table 5.1, it can be inferred that the liquids having strong intermolecular forces do not vaporize easily and their vapour pressures are low. Water, due to strong hydrogen bonding has lower vapour pressure than ethanol and, the latter has lower vapour pressure than diethyl ether. Metallic bonding signifies strong interaction among the atoms: as a result of this, mercury has low vapour pressure.

As the temperature of a liquid increases, the average kinetic energy of the molecules also increases. The number of molecules escaping as vapour also increases. Hence, the vapour pressure increases with temperature. To illustrate this, the vapour pressures of water at different temperatures are given in Table 5.2.

Table 5.2: Vapour Pressures of Water at different Temperatures

Temperature / K	Vapour Pressure/Pa
283	$1.226 \times 10^3$
293	$2.330 \times 10^3$
323	$1.233 \times 10^4$
348	$3.550 \times 10^4$
373	$1.013 \times 10^5$

There is a quantitative relationship, known as *Clausius- Clapeyron equation*, between the vapour pressure of a liquid and its temperature. Let us now define the boiling point of a liquid.

### 3.1.2 Boiling point

The temperature at which the vapour pressure of a liquid equals the external pressure is called its *boiling point*. At this temperature, the vapour produced in the interior of the liquid results in continuous bubble formation that is characteristic of boiling. The temperature of a boiling liquid (even with the absorption of heat) remains constant until all the liquid has been vaporized.

The boiling point of a liquid at  $1.013 \times 10^5$  Pa (1 atm) pressure is called its normal boiling point. The boiling points mentioned in this course are normal boiling points. A less volatile liquid (i.e. a liquid which has low vapour pressure at room temperature) is to be heated to a higher temperature so that its vapour pressure equals atmospheric pressure. That is a less volatile liquid has a high boiling point. On the contrary, a more volatile liquid (i.e. a liquid having high vapour pressure at room temperature) needs to be heated less to make it attain atmospheric pressure and thus has a low boiling point.

Let us now study the effect of external pressure on boiling point. The boiling point increases as external pressure increases and the boiling point decreases as external pressure decreases. This principle is made use of in distillation process under reduced pressure (Fig. 5.3). It means making a liquid boil at a pressure lower than atmospheric pressure. If a liquid has a high boiling point and decomposes when heated, it can be made to boil at a lower temperature by reducing the pressure. For reducing the pressure, a vacuum suction pump is used.

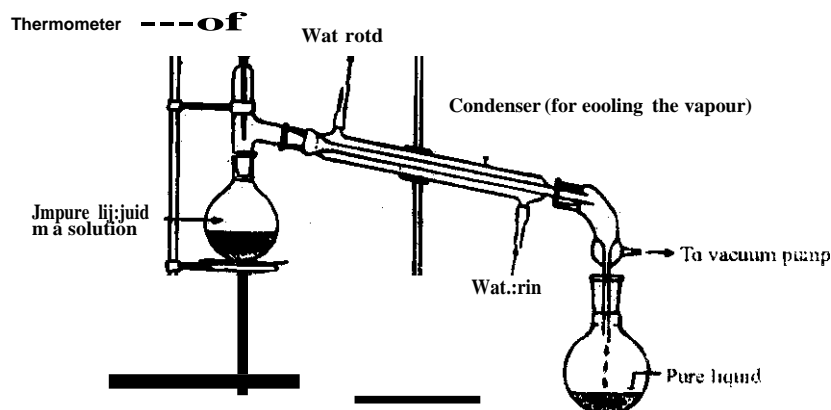

Fig 5.3. *Reduced pressure distillation*

Distillation under reduced pressure is often used in the separation and purification of organic and inorganic compounds. A commercial application is that excess water content is removed from many food products by boiling under reduced pressure. An alternate way of looking at Table 5.2 is that it gives boiling points of water at different external pressures. Thus at a reduced pressure of  $1.226 \times 10^4$  Pa (0.0103 atm), water boils at 283 K; the boiling point of water is lowered by 90K at this pressure.

In Module 3, Unit 4, we learnt about the correlation between boiling points and intermolecular forces. It is interesting to note that intermolecular forces have similar effect on the boiling points and the molar enthalpies of vaporization, if comparisons are restricted to similar compounds. Let us examine Table 4.1 of Unit 4, Module 3 from this angle: Water has stronger hydrogen bonding than ethanol, the boiling point and molar enthalpy of vaporization of ethanol are higher than that of the alkanes. Effect of

metallic bonding is clearly seen in the high values of boiling points and molar enthalpies of vaporization of mercury, silver and aluminum.

The parallel between the molar enthalpies of vaporization and the boiling points of liquids led Trouton to suggest a relationship between the two quantities. Before studying Trouton's rule, organize your thoughts by answering the following exercises.

#### Exercise 1

The vapour pressure of methanol is higher than that of ethanol at 300 K. Suggest a reason.

#### Exercise 2

Arrange the following compounds in the increasing order of boiling points: ethanol, glycerol and ethylene glycol.

### 3.2 Trouton's Rule

Trouton's rule can be stated as follows:

The ratio of molar enthalpy of vaporization of a liquid to its boiling point is approximately  $85 \text{ J mol}^{-1} \text{ K}^{-1}$

$$\frac{\Delta_{\text{vap}}H_m}{\text{BP}} = 85 \text{ J mol}^{-1} \text{ K}^{-1}$$

Trouton's rule holds good for liquids in which hydrogen bonding is absent. The ratio,  $\Delta_{\text{vap}}H_m/\text{BP}$  is also known as *entropy of vaporization*. It is a measure of disorderliness gained by a substance due to vaporization. During vaporization, a hydrogen bonded liquid gains more disorderliness as compared to a non-hydrogen bonded liquid: hence  $\Delta_{\text{vap}}H_m/\text{BP}$  is more than  $85 \text{ J mol}^{-1} \text{ K}^{-1}$  for hydrogen liquids. For example, the values of  $\Delta_{\text{vap}}H_m/\text{BP}$  for water and ethylalcohol are 109 and  $112 \text{ J mol}^{-1} \text{ K}^{-1}$ , respectively.

For non-polar liquids, Eq. 3.1 is useful in calculating the boiling point or molar enthalpy of vaporization, if either is known. Let us calculate the molar enthalpy of vaporization of benzene: its boiling point is 352 K. Using Eq. 3.1,

$$\begin{aligned} \Delta_{\text{vap}}H_m &= 352 \text{ K} \times 85 \text{ J Mol}^{-1} \text{ K}^{-1} \\ &= 30 \text{ kJ Mol}^{-1} \end{aligned}$$

The experimental value is  $31.1 \text{ kJ Mol}^{-1}$

So far, we have studied the characteristics of liquids. There is a class of compounds, known as liquid crystals, which flow like liquids and have structural similarity to solids. We take up the study of liquid crystals in the next section: before going through the next section, it is better you try the following Self Assessment Question (SAQ)

#### Exercise 3

Calculate the molar enthalpy of vaporization of carbon tetrachloride which boils at 350 K.

### 3.3 Liquid Crystals

Gases and liquids are *isotropic*. This means for any gas or liquid, the value of any of the physical properties such as refractive index, coefficient of thermal expansion, electrical conductivity, speed of sound etc is same in all directions. In contrast to this, a crystalline solid when examined as an individual crystal (or a single crystal) behaves in a different way. Depending upon the direction in which the crystal is kept during measurement, it may have a different value for its physical properties mentioned above. Such a single crystal is anisotropic. In some cases different faces of crystal may show different catalytic activity. Another class of compounds which are anisotropic is liquid crystal. Let us first define the term 'liquid crystal' and then see how its anisotropy gives rise to interesting applications.

Some organic compounds often have two melting points. On heating such a crystal, it melts into a turbid liquid at a definite temperature, and on heating further, the turbid liquid becomes clear at another temperature. The turbid liquid is called '**liquid Crystal**'.

A number of compounds of the following type exists as liquid crystals:

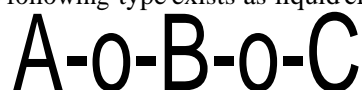

A, U and Care substituents on carbon chains.

An example is p-azoxyanisole

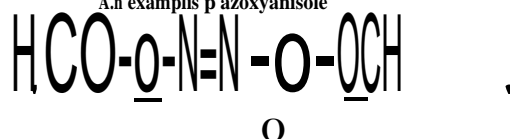
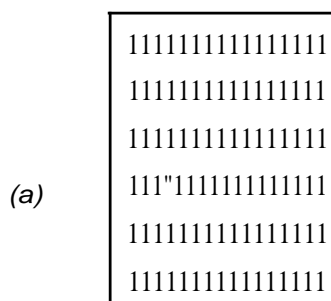

Fig. 5.4: *p-Azoxyanisole*

These molecules have a length that is larger than breadth. In general, the arrangement of molecules in liquid crystals resembles a pile of cigars.

Depending upon the structural pattern of molecules, liquid crystals can be classified as follows:

**Smectic Liquid** crystals have molecules arranged in parallel layers or planes. These planes are at equal distances. The molecules in all the planes point to the same direction. That is, the molecules have same orientation. The only difference between a solid crystal (Fig 5.5a) and a smectic liquid crystal (Fig 5.5b) is that in the former, the particles are arranged at regular intervals within a plane; whereas in the latter it is not so.



Arrangement in equidistant Planes. regular within planes – a single crystal

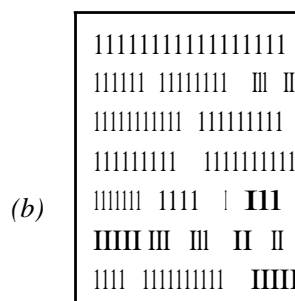

Same orientation arrangement in equidistant planes: no regularity within planes - smectic liquid crystal



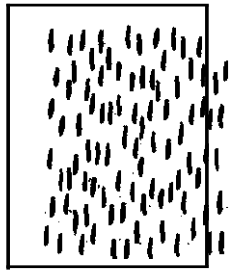

Same orientation: absence of plane arrangement nematic liquid arrangement

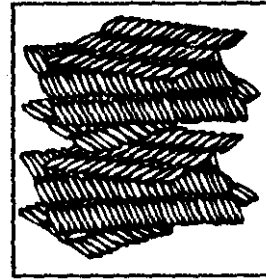

(d)

Multiple layers with successive twist: same orientation within a layer – cholesteric crystal

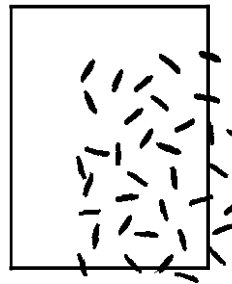

(e)

Neither orientation nor planar arrangement - Liquid (giving rise to Isotropy)

Fig. 5.5: (a), (b), (c), (d) and (e)

**Nematic Liquid Crystals** have all the molecules within the same orientation (Fig 5.5c). Unlike smectic type, the molecules are not arranged in planes in nematic liquid crystals. Application of an electric field causes a change in the orientation of the molecules in a nematic liquid crystal. A change in molecular orientation causes a change in optical properties. It is this anisotropic character that makes a nematic liquid crystal useful in LCD (Liquid crystal display) watches and calculators.

**Cholesteric liquid crystals** have a multiple layer structure, but each successive layer is inclined or twisted slightly. Fig 5.5d illustrates the cholesteric liquid crystal structure. For comparison, the typical disorderly arrangement of molecules (accounting for isotropy) in a liquid is shown in Fig 5.5e.

The successive twist in structure makes the cholesteric liquid crystals coloured. A minute change in temperature causes a change in the amount of twisting. It results in reflection of different wavelength of visible light; that is, the colour changes with temperature. This anisotropic nature facilitates cholesteric liquid crystals being used in thermometers and in devices for indicating the temperature of the skin or of electrical devices. Temperature changes as small as 0.001 K can be detected using sensitive cholesteric liquid crystals. This class of liquid crystals received their name from the fact that many derivatives of cholesterol pertain to this type.

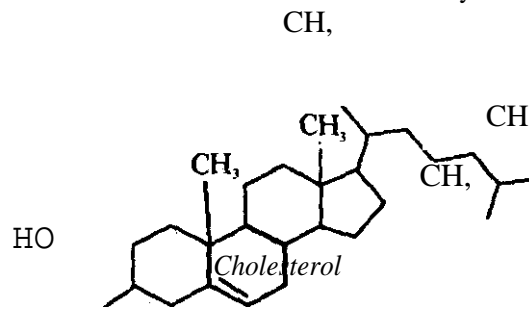

We see that a difference in the orientation of molecules in a nematic or a cholesteric liquid crystal causes a difference in its optical properties, thereby pointing to its anisotropic nature. On the basis of what you have studied so far, answer the following exercise:

Exercise 4

In what way, is an isotropic substance different from an anisotropic substance ?

#### 4.0 Conclusion

In this Unit, we were able to state and explain the Trouton's rule. The terms isotropy and anisotropy were defined. The applications of anisotropic character of liquid crystals were illustrated. More information on liquids solution is presented in the next three Units.

#### 5.0 Summary

At the end of this Unit, you have learnt that:

- Three of the characteristic properties of liquids are:
  - (i) sharply defined surface;
  - (ii) flowing ability;
  - (iii) tendency to vaporize into space and to exert vapour pressure.
- Trouton's rule is the ratio of molar enthalpy of a liquid to its boiling point.

#### 6.0 Tutor-Marked Assignment

- (1) Explain the reason for the anisotropy in the optical properties of nematic and cholesteric liquid crystals.
- (2) The molar enthalpy of vaporization and boiling point of ammonia are  $23.3 \text{ kJ mol}^{-1}$  and  $240 \text{ K}$ , respectively. Does it obey Trouton's rule?

## **MODULE 4: SOLUTIONS AND PHASE EQUILIBRIA**

### **Umt I: Types of Solution**

#### **Table of Contents**

	<b>Page</b>
1.0 Introduction	<b>III</b>
2.0 Objectives	III
3.1. Definition of Basic Terms	III
3.1.1 Pure Substances and Solutions	<b>III</b>
3.1.2 Differentiating Between Pure Substances and Solutions	112
3.2. Types of Solutions	112
3.2.1. Gaseous Solution	113
3.2.2 Liquid Solutions	113
3.2.3 Solid Solutions	114
3 3. Different Ways of Expressing the Composition of Solutions	114
4 0 Conclusion	lin
5.0 Summary	lin
6.0 References and Other Resources	116
7.0 Tutor-Marked Assigmr.ent	<b>116</b>

## 1.0 Introduction

We have been exposed to different substances in life. Specifically, we must have familiarized ourselves with pure substances like sodium chloride, sugar, water and ethyl alcohol. You will agree that these substances are different. By mere looking at them, you can tell some possible differences. For examples, sodium chloride is powder while sugar is crystalline, but you cannot identify some properties by mere looking at the two substances for example, sodium chloride is an ionic compound while sugar is an organic compound but you can say that both are solids. They have different definite density and melting points, which we can confirm. The four substances mentioned earlier can mix each with any other substance to form a solution. That means there must be different solutions formed. In this Unit, we shall discuss different solution types.

## 2.0 Objectives

By the end of this Unit, you should be able to:

- Make a distinction between pure substances and solutions.
- Define a solution and other relevant terms.
- List various types of solutions providing at least two examples each.

## 3.1 Definition of Basic Terms

### 3.1.1 Pure Substances and Solutions

Quickly carry out this simple activity on your own.

#### Activity 1

Aim: To observe the differences between pure substances and solutions.

Apparatus: Sodium Chloride salt, granulated Sugar, ethyl alcohol, distilled water as reagents, 4 big test tubes, a chemical balance, filter paper.

#### Procedure

1. Measure 0.5g of NaCl, 0.5 g of sugar and 5cm<sup>3</sup> of ethyl alcohol.
2. Measure 10cm<sup>3</sup> of water into three test tubes.
3. Pour each of the substances in Step 1 into the 3 test tubes containing water.
4. Repeat the activity using ethyl alcohol instead of water.
5. Record your observation.

Did you observe that:

- (1) NaCl and Sugar dissolved in water!
- (2) Ethyl alcohol and water produced a liquid similar in appearance to the two original liquids!

These salt-water mixture, the sugar-water mixture and the alcohol-water mixtures are called Solutions. A solution can be defined as a homogeneous mixture of two or more substances. In other words, the mixture formed is said to be a single phase.

Let us consider salt-water mixture. There are two constituents in the mixture. One is a solute and the other a solvent. Assuming you have more than three constituents in a solution, one will be the solvent while all other constituents in that solution are referred to as solutes.

Assuming we add 0.5g of NaCl to 500cm<sup>3</sup> of water compared to 0.5g we added to 100cm<sup>3</sup> of water. The mixture of 0.5g in 500cm<sup>3</sup> of water can be said to contain relatively small quantity of solute. Such a solution is said to be **diluted**. The mixture of 0.5g in 100cm<sup>3</sup> of water that can be said to contain relatively large quantity of solute is said to be concentrated.

### 3.1.2 Differentiating Between Pure Substances and Solutions

In nature, do you know we have both pure and impure substances? We have considered NaCl and C<sub>6</sub>H<sub>12</sub>O<sub>6</sub>, that are solutes. Each of these two substances contains particles that are uniform. After we obtained the salt-water and sugar-water mixtures, the substances are also homogeneous. We can say then that both pure substances (examples of NaCl and Sugar) and solutions (examples of salt-water and sugar-water mixtures) are homogeneous. But can you tell the difference? A pure substance is a homogeneous material that contains only one substance whereas a solution is a homogeneous material that contains more than one substance. A pure substance is further characterised by definite properties such as density, vapour pressure, melting and boiling points, the properties of a solution depends upon the relative amounts of constituents. For an example, the salt-water mixture consists of a single phase. Its density is greater than that of pure water. It is equally found out that its vapour pressure is lower than the vapour pressure of pure water. Do you agree with that last sentence? If you do, give a reason for your agreement. The reason given must be close to the fact that to raise the vapour pressure to 760mm, pure water must be heated to 100°C. But to reach this vapour pressure, it is discovered that salt-water must be heated above 100°C. One can infer that the boiling point of salt-water is above the boiling point of pure water.

#### Exercise 1

Predict the following:

1. When more salt is added to the salt-water mixture, will the boiling point be lower or higher?
2. To crystallize ice from salt-water, will the temperature be lower or higher than crystallizing ice from pure water?

There are some terms we used in explaining homogeneity. We will examine these terms as we proceed to study types of solutions.

## 3.2 Types of Solutions

A solution may exist in solid, liquid or gaseous state. Depending upon the physical state, a solution may be classified into the types shown in Table 1.1.

Table 1.1: Types of Solutions

Solute	Solvent	Example
Gas	Gas	Mixture of gases (e.g., air)
Gas	Liquid	Aerated water (which is a solution of CO <sub>2</sub> in water under pressure)
Gas	Solid	Gas absorbed by metals or minerals (e.g. H, in palladium)
Liquid	Gas	Moist air
Liquid	Liquid	Alcohol in water
Liquid	Solid	Mercury in zinc (zinc amalgam)
Solid	Gas	Camphor in air
Solid	Liquid	Salt in water
Solid	Solid	Alloys (e.g., brass)

A solution is always in the same physical state as the solvent. In this Unit, we shall study solid-liquid, gas-liquid and liquid-liquid solutions.

### Exercise 2

Classify the following into the types of solutions to which they belong:

- (i) A five kobo coin
- (ii) Sodium amalgam
- (iii) Soda Water

### 3.2.1 Gaseous Solutions

In Table 1.1, gas solute dissolves in gas solvent to form a gas homogeneous mixture. You are given air as an example of a gas solution. There is only one phase- the gas phase. What is a phase? A *phase* refers to a homogenous part of a system that is uniform and alike throughout. With the definition of a gas phase, we can say that all the molecules behave as gas molecules. This is applicable to any gas solution, whatever the source of the constituents. Can you list out other gas solutions apart from the ones listed in Table 1.1. An example is camphor in air. However the constituents can be separated by phase changes. We will consider the details of phase changes in due course.

### 3.2.2 Liquid Solutions

In your laboratory work, you will be handling more of liquid solutions. I want you to make some attempts at mentioning some liquid solutions without checking on Table 1.1. You will be correct to mention groundnut oil-water mixture, alcohol-water mixture, salt-water etc in other words, liquid solutions can be prepared by dissolving a gas in a liquid (for example carbon (IV) oxide in water under pressure) or by mixing two liquids (for example alcohol and water) or by dissolving a solid in a liquid (for example salt-water mixture). In such a liquid solution, the other constituent dilutes one; of the constituents. We have in section 3.1.2 distinguished some of the properties of liquid solution from pure water.

### 3.2.3 Solid Solutions

Naturally, solid solutions are uncommon. In Module 3, Unit L we discussed some of the properties of solids. One of these is that their crystals are stable due to the regularity of the positioning of the atoms. However, in metals, it is relatively common for solid solutions to be formed. In Table 3.I, brass is an example. The atoms of one element enter the crystal of another element especially if their atoms are of similar size. What atoms of elements combine to form the brass alloy? Other solid solutions include zinc amalgam and H<sub>2</sub> in palladium. You would have noticed that the solvent component determines the name given to the type of solution formed.

## 3.3 Different Ways of Expressing Concentration of Solutions

For us to indicate the composition of a solution, we must have an idea of the relative amount of the different kinds of constituents in that solution. Chemists call these relative amounts as *concentration*. The relative amounts of a solute and a solvent in a solution are expressed through concentration terms. Some of the ways of expressing the concentration of a solution are described below:

### (i) Molarity (M)

Molarity is defined as the number of moles of the solute present in 1 dm<sup>3</sup> (1 L or 10<sup>3</sup> m<sup>3</sup>) of the solution. When 0.1 mole of a solute is present in one cubic decimeter of the solution, we say that the solution is 0.1 molar (0.1 M).

$$\text{Molarity (M)} = \frac{\text{Number of moles of the solute}}{\text{Volume of the solution in dm}^3}$$

Note that the volume of the solution should be expressed in dm<sup>3</sup> for expressing the concentration in terms of molarity.

### Example 1

What is the M of a solution prepared by adding 100g of NaCl to sufficient H<sub>2</sub>O to make 1 dm<sup>3</sup> of solution?

### Solution

58.3g = 1 mole

$$100 \text{ g} \times \frac{1 \text{ mole}}{58.3 \text{ g}} = 1.71 \text{ mol}$$

M = number of moles per volume of the solution = 1.71 mol/dm<sup>3</sup>

**1.71 M**

### (ii) Molality (m)

Molality is defined as the number of moles of solute present in one kilogram of the solvent. When one mole of solute is dissolved in one kilogram of water, the concentration of the solution is one molal (1 m)

$$\text{Molality (m)} = \frac{\text{Number of moles of solute}}{\text{Mass of the Solvent in kg}}$$

### (iii) Normality (N)

The number of gram-equivalents of a solute present in 1 dm<sup>3</sup> of the solution is called its normality. A normal solution contains one gram-equivalent of a solute in 1 dm<sup>3</sup> of solution and is defined by:

$$\text{Normality (N)} = \frac{\text{Strength in g/dm}^3}{\text{Equivalent weight}}$$

Exercise 3

Calculate the molarity of a solution prepared by dissolving 0.4 moles of solute in sufficient solvent to make 0.20 dm<sup>3</sup>

.....  
 .....  
 .....

(iv) Mole fraction (x)

The mole fraction of a solute in a solution is the ratio of the number of moles of a solute to the total number of moles of the solute and the solvent in a solution. If n<sub>1</sub> mole of a solute is dissolved in n<sub>2</sub> mole of a solvent the mole fraction of the solvent and the solute are given by the following expressions:

$$\text{Mole fraction of the solvent } (x_2) = \frac{n_2}{n_1 + n_2}$$

$$\text{Mole fraction of the solute } (x_1) = \frac{n_1}{n_1 + n_2}$$

(v) Percentage

In terms of percentage, the concentration of a solution may be expressed in four different ways:

$$10 \text{ mL of alcohol present in } 100 \text{ mL of solution} = 10\% \text{ (VN)}$$

$$10 \text{ g NaCl present in } 100 \text{ mL of solution} = 10\% \text{ (WN)}$$

$$10 \text{ mL alcohol present in } 100 \text{ g of solution} = 10\% \text{ (V/W)}$$

$$10 \text{ g NaCl present in } 100 \text{ g of solution} = 10\% \text{ (W/W)}$$

(vi) Parts per million (ppm)

When a solute present in a solution is in very minute amounts, the concentration is usually expressed in parts per million (ppm). For example, the amount of oxygen dissolved in seawater is 5.8 g per 10<sup>6</sup> (1 million) of seawater. It means 5.8 parts of oxygen are present in one million parts of seawater. Hence, the concentration of oxygen in seawater is 5.8 ppm. The concentration of gases that pollute the atmosphere is also expressed in ppm.

$$\text{One ppm} = \frac{\text{Mass of solute (g)} \times 10^6}{\text{Total mass of solution (g)}}$$

Let us work out an example using the molarity expression explained above.

Example ■

Concentrated tetraoxosulphate (vi) acid contains 98% acid by weight. Its density is 1.85 × 10<sup>3</sup> kg m<sup>-3</sup>. Calculate its molarity.

Solution

$$\text{Molarity of Tetraoxosulphate (vi) acid} = \frac{\text{Number of moles of tetraoxosulphate (vi) acid}}{\text{Volume in dm}^3}$$

$$\text{Mass of H}_2\text{SO}_4 \text{ acid in } 1 \text{ m}^3$$

$$\text{Molar mass} \times 10^3 \text{ dm}^3$$

$$98 \times 1.85 \times 10^3 \text{ kg} \times$$

$$100 \times 0.098 \text{ kg mol}^{-1}$$

$$18.5 \text{M}$$



#### Exercise 4

A solution contains 0.100 kg each of water and ethanol. Find the mole fraction of each component.

### 4.0 Conclusion

In this Unit, we have expressed a solution as a homogeneous mixture of two or more substances. The three phases at which solutions are formed namely solid, liquid and gaseous are also discussed. Solutions can be divided into nine types depending upon the physical state of the solute and the solution. The composition of the solution can be measured.

### 5.0 Summary

We can summarise what we have learnt as follows:

- A phase is a homogeneous part of a system which is susceptible to change on certain conditions
- Different solutions exist namely solid solutions, liquid solutions and gaseous solutions.
- In solid solution, the solid is the solvent and examples include zinc amalgam and H<sub>2</sub> in palladium.
- In liquid solution, the liquid is the solvent and examples include ethanol and salt water.
- In gaseous solutions, the gas is the solvent and examples include air and camphor in air.

### 6.0 References and Other Resources

Golberg, D. and Dillard, C. (1974) College Chemistry 3rd Revised Edition New York: Macmillan Publishing Co.

IGNOU (1993). Solution and Phase Equilising- Physical Chemistry 2 CHEM -04 New Delhi.

### 7.0 Tutor-Marked Assignment

I. Fill in the blanks in the following:

- (i) The solubility of a solute \_\_\_\_\_ with increase in temperature when the dissolution is accompanied by absorption of heat.
  - (ii) One molal solution contains a mole of a solute dissolved in \_\_\_\_\_ of the solvent.
  - (iii) In an ideal solution, partial vapour pressure of a component of a solution is mole fraction  $\times$  \_\_\_\_\_.
  - (iv) The constituents of \_\_\_\_\_ solution can be separated by fractional distillation into pure components.
2. Explain why we cannot prepare absolute alcohol by fractional distillation.
  3. If 0.100 kg of an aqueous solution of potassium chloride contains  $7.45 \times 10^{-2}$  kg of the solute, then calculate the molality of the solution.

## Unit 2: Solutions of Solids and Gases in Liquids

### Table of Contents

	<b>Page</b>
1.0. Introduction	ii&
2.0 ObJectives	118
3.1 Solutions of Solids in Liquids	118
3.2 Solution of Gases in Liquids	119
3.2.1 Factors affecting SolubilitY of Gases	119
4.0 Conclusion	122
5.0 Smmnary	122
6.d References and Other Resources	122
7.0 Tutor-Marked Assignment	122

## 1.0 Introduction

There is no doubt that some variations exist among the properties of different solution types. In this Unit, we shall examine solutions of solids in liquids and solutions of gases in liquids. All the phenomena that characterized these solution types would be discussed in this Unit.

## 2.0 Objectives

By the end of this Unit, you shall be able to:

- Define Solubility
- Express the composition of solutions
- Explain the variations among the properties of solutions.

## 3.1 Solutions of Solids in Liquids

In solutions of solids in liquids, the liquid is referred to as the solvent and, the solid which is dissolved in it, as the solute. When a solid is added gradually to a given amount of a liquid (solvent) at the constant temperature, a state is reached when some of the solid remains undissolved. Then the solution is said to be a saturated solution. The mass of the solute that can be dissolved in 100g of a solvent to form a saturated solution at a given temperature is called its solubility. The solubility of a substance is the concentration of the substance in a saturated solution at a specified temperature and can be expressed as mol  $\text{dm}^{-3}$  or g per 100g of solvent.

Assuming you are to determine the solubility of a solute in mol  $\text{dm}^{-3}$  in which 11.2 g  $\text{Mg}(\text{NO}_3)_2$  were dissolved in 112 g of distilled water at 298 K. Try to make an attempt.

Solubility of a solid in a liquid varies with temperature. The plot of solubility against temperature is called the solubility curve. Some typical solubility curves are shown in Fig 2.1.

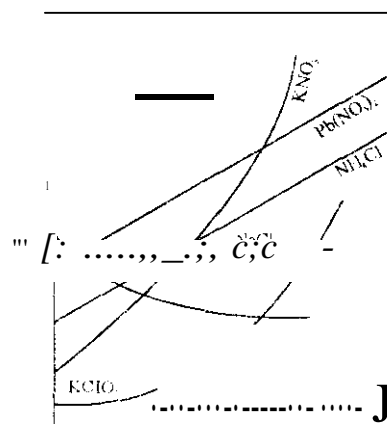

Fig 2.1. Solubility curves of different solutes:  
S stands for solubility and T for temperature

### Exercise 1

Use Fig 2.1 to answer the following questions:

- Which of the substances is least soluble at the arbitrary highest temperature specified?
- Which of the  $\text{NH}_4\text{Cl}$  and  $\text{KClO}_4$  is more soluble at the arbitrary lowest temperature?
- Which of the solute in a solution is the least affected by temperature?

The solubilities of many of the ionic substances in water increase with temperature. The solubility of sodium chloride increases to a very small extent with rise in temperature. The solubility of calcium acetate decreases

with rise in temperature. In many cases, when a solute is dissolved in a solvent, heat is absorbed, i.e. cooling results. Then according to Le Chatelier's principle, when the temperature of a saturated solution in contact with the solute is raised, a change will take place such that there is absorption of heat, i.e. along the direction in which cooling takes place. The solubility of the substance will, therefore, increase with rise in temperature.

The dissolution of some salts in water (e.g. calcium salts of organic acids) is accompanied by evolution of heat. Evidently, the solubility of such salts decrease with rise in temperature.

## 3.2 Solutions of Gases in Liquids

Most of the gases dissolve in water or some other liquids to a greater or less extent. In a gas the molecules are far apart. After dissolution in a liquid solvent, the molecules of the gas are much closer, it is just like saying that before a gas dissolves in liquid, it must be condensed to give a liquid. The condensation of a gas is an exothermic process. The enthalpy of condensation is larger than the enthalpy of solution. Thus the dissolution of a gas is an exothermic process (i.e. heat is evolved). The solubility of a gas in a liquid is measured in terms of absorption coefficient or Bunsen coefficient. This coefficient has been named after the scientist, Bunsen, who introduced it. It is denoted by  $\alpha$ , it is defined as the volume of a gas at standard temperature and pressure (273.15 K and  $1.013 \times 10^5$  Pa) dissolved by unit volume of the solvent at the temperature of the experiment and under a pressure of  $1.013 \times 10^5$  Pa. The absorption coefficients of some gases are given in Table 2.1.

Table 2.1: Absorption Coefficients at 293 K

Solvent	Carbon (IV) Oxide	Hydrogen	Oxygen	Nitrogen
Water	0.88	0.018	0.028	0.015
Ethanol	3.00	0.081	0.142	0.130
Benzene	---	0.060	0.165	0.105

### 3.2.1 Factors affecting Solubility of Gases

The solubility of a gas in a liquid depends upon:

- Temperature
- Pressure, and
- Nature of the gas and the solvent.

We will consider each of these factors separately.

#### 1. Effect of temperature

The dissolution of a gas in a liquid is an exothermic process. Hence, according to Le Chatelier's principle, the solubility of a gas in a liquid decreases with rise in temperature. This behaviour can be seen when bubbles of dissolved air escape on heating water below 373 K.

#### 2. Effect of pressure- Henry's law

The solubility of solids in liquids is not so much affected by pressure, as the volume changes are not so high, but the solubility of a gas in liquid varies considerably with pressure. In 1803, the English Chemist, Henry found that the solubility of a gas increases as the gas pressure is increased at a given temperature. He proposed the generalization that is known as Henry's law. It may be stated as follows:

At constant temperature, the partial pressure of a gas over a solution is directly proportional to the concentration of the gas in the solution.

For example, doubling the pressure of oxygen, doubles the amount of oxygen that will dissolve in a given amount of the solvent

Mathematically, Henry's law is expressed as follows:

$$p = Kx \quad \dots \dots \dots, 3.1$$

Where  $p$  is the partial pressure of the gas over the solution and  $x$  is the solubility of the gas in terms of its mole fraction in the solution;  $K$  is a constant, characteristic of the specific combination of the solvent and the gas. It is called Henry's law constant. The partial pressure is expressed in terms of Pascal (Pa).

From Eq. 3.1, the Henry's Law constant is given as

$$K = \frac{p}{x} \dots \dots \dots 3.2$$

$K$  has the dimensions of pressure.  $K$  is not constant as expected from Eq. 3.2 because of non ideality of the solution. Its value is obtained by plotting the ratio  $p/x$  vs  $x$  and extrapolating to  $x = 0$ . Such a graph is shown in Fig 2.2.

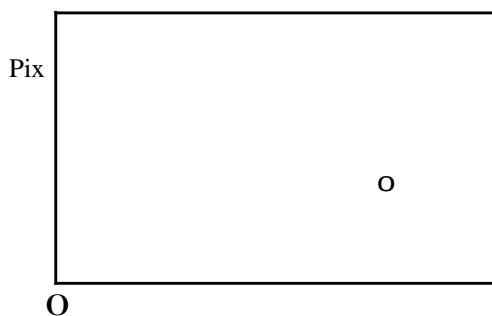

Fig 2.2: Extrapolation of Henry's law constant

Henry's law constants for some gases are given in Table 2.2:

Table 2.2: Henry's Law Constants at 298 K

Gas	$K/10^5$ Pa In water	In benzene
N <sub>2</sub>	7.12	0.37
O <sub>2</sub>	8.68	0.24
CO	4.40	-
CO <sub>2</sub>	5.80	0.16
CO <sub>2</sub>	0.17	0.01

It has been found that Henry's law is followed most closely by dilute solutions of gases that do not react with the solvent. Thus the law is valid for the solubility of hydrogen chloride and ammonia in water. Hydrogen chloride ionizes in water and ammonia enters into chemical combination with water.

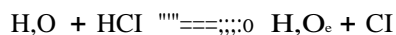

### 3, Nature of the gas and the solvent

Generally, gases, which react chemically with the solvent are more soluble in it than in other solvents. For example, hydrogen chloride gas is more soluble in water than in benzene. Gases, which can be easily liquefied, are more soluble in common solvents.

#### Example 2

The Henry's law constant for  $\text{O}_2$  is  $4.40 \times 10^9$  Pa. Calculate the molarity of oxygen in water at 298 K. The partial pressure of oxygen over the solution is  $1.00 \times 10^5$  Pa. Assume that  $1.00 \text{ dm}^3$  of the aqueous solution weighs 1.00 kg.

#### Solution

$$K = 4.40 \times 10^9 \text{ Pa}$$

$$P = 1.00 \times 10^5 \text{ Pa}$$

Mole fraction of oxygen,

$$x_{\text{O}_2} = \frac{n_{\text{O}_2}}{n_{\text{O}_2} + n_{\text{H}_2\text{O}}}$$

$n_{\text{O}_2}$  is negligible in comparison to the number of moles of  $\text{H}_2\text{O}$ .

$$\text{then } x_{\text{O}_2} = \frac{n_{\text{O}_2}}{n_{\text{H}_2\text{O}}}$$

Substituting the values in Eq. 3.1, we get

$$n_{\text{O}_2} = 1.26 \times 10^{-3} \text{ mol dm}^{-3}$$

In other words, the solubility of oxygen in water at 298 K is  $1.26 \times 10^{-3} \text{ mol dm}^{-3}$ . Since 1 kg (or  $1 \text{ dm}^3$ ) of the solution contains  $1.26 \times 10^{-3} \text{ mol}$  of oxygen.

#### Exercise 2

Why can fish not live in warm water?

## 4.0 Conclusion

In this Unit, we have expressed a solution as a homogenous mixture of two or more substances. The three phases at which solutions are formed namely solid, liquid and gaseous are also discussed. Solutions can be divided into three types depending upon the physical state of the solute and the solution. The composition of the solution can be measured. Pressure has only a small effect on the solubility of solids in liquids. The solubility of a gas varies with pressure. All these two phenomena are also discussed in this Unit.

## 5.0 Summary

We can summarise what we have learnt as follows

- A phase is a homogeneous part of a system which is susceptible to change on certain conditions
- Different solutions exist but can be differentiated into solid solution, liquid solution and gaseous solutions
- The solubility of a gas in a liquid depends upon temperature, pressure and nature of the gas and the solvent

## 6.0 References and Other Resources

Goldberg and Dillard, C. (1974) College Chemistry 3rd Revised Edition New York Macmillan Publishing Co

IGNOU (1993) Solution and Phase Equilibrium - Physical Chemistry 2 CHEM -04 New Delhi.

## 7.0 Tutor-Marked Assignment

1. The vapour pressures of pure liquids A and B at 300 K are  $2.0 \times 10^4$  Pa and  $0.8 \times 10^4$  Pa, respectively. Calculate the mole fractions of A and B in vapour and liquid phases of a solution when the equilibrium total vapour pressure of the binary liquid solution is  $4.5 \times 10^4$  Pa at 300 K. Assume that the liquid and the vapour are ideal.
2. The solubility of carbon (IV) oxide in water at 298 K is  $3.40 \times 10^{-2}$  mol  $\text{dm}^{-3}$ . The partial pressure of  $\text{CO}_2$  over the solution is  $1.00 \times 10^5$  Pa. Assuming that one  $\text{dm}^3$  of the solution contains 100 kg of water calculate the Henry's law constant for carbon (IV) oxide.

## Unit 3: Binary Liquid Solutions- 1

### Table of Contents

	Page
1.0 Introduction	124
2.0 Objectives	124
<b>3.1.</b> Binary Liquid Solutions	124
<b>3.2.</b> Raoult's Law	124
3.2.1 Ideal Solutions	<i>US</i>
3.2.2 Non-Ideal Solutions	125
3.3. Ideal Solutions of Volatile Solutes	127
3.4 Raoult's Law Curves	127
4.0. Conclusion	127
5.0. Summary	129
<b>6.0</b> Tutor Marked Assignment	130



## 1.0 Introduction

In Module 4, Unit 2, we considered solutions of solids and gases in liquids. This Unit is devoted to solution of liquids in liquids because you will be dealing mostly with this type of solution. And it is important to understand their behaviours. In the liquid – liquid type of solution, we will consider only binary liquid solution at this level of your programme. We will discuss the differences between ideal and non-ideal solutions and explain which of these obey Raoult's law

## 2.0 Objective

By the end of this Unit, you should be able to:

- Explain the concept of binary liquid solution
- State Raoult's Law
- Distinguish between ideal and non-ideal
- Discuss Raoult's Law curves.

## 3.1 Binary Liquid Solutions

You must have heard of binary compounds. What are they? They are compounds that are composed of only two elements. These elements could be a metal and a non-metal and they can also be metals. In the case of binary liquid solution, make an attempt to explain what it means. Binary liquid solutions are liquid solutions composed of two liquids. When two liquids A and B are mixed completely there are three possibilities:

- (i) Liquid A is completely miscible with liquid B in all proportions (e.g. water and ethanol, toluene and benzene, etc.).
- (ii) Liquids A and B are only partially miscible in each other (e.g. water and phenol).
- (iii) Liquids A and B are completely immiscible with each other (e.g., water and palm oil).

We shall study completely miscible liquid systems in this Unit. The other two types will be taken up for study in Unit 5.

### Completely miscible liquids

When liquid A is completely miscible with liquid B in all proportions. A miscible liquid solution is obtained. Let us consider examples of such liquids.

Assuming water and ethanol mixed to form a liquid solution, a water ethanol solution is formed. Another example is toluene and benzene. Now I want you to make a list of 5 miscible liquid solutions. Many more of this type of binary liquid solution can be obtained. In the next Unit, we will examine other possibilities. Next is a discussion on Raoult's law.

## 3.2 Raoult's Law

Consider a binary solution containing two liquids A and B which are completely immiscible with each other in all proportions. In such solutions, the terms, solute and solvent, can be interchanged for the two components. In 1880, the French chemist, Raoult found that when a non volatile solute is dissolved in a solvent (liquid), the vapour pressure of the solvent decreases. If the solute and the solvent are both volatile the vapour pressures of both the components are decreased. Based on these observations, he gave the following generalization which is called Raoult's Law.

The partial vapour pressure of any volatile component in a solution is equal to the product of the vapour pressure of the pure component and its mole fraction in the solution.

If  $x_A$  and  $x_B$  are the mole fractions of the components A and B in the liquid solution and  $p_A^0$  and  $p_B^0$  the vapour pressures of these components respectively, then according to Raoult's law,

$$p_A = p_A^0 x_A \quad \dots\dots\dots, \dots, \dots \quad 3.1$$

**and**  $P_B = p_B^0 x_B \quad \dots\dots\dots \quad 3.2$

If the vapour behaves like an ideal gas, then according to Dalton's law of partial pressure, the total vapour pressure,  $p$ , is given by

$$P = P_A + P_B = p_A^0 x_A + p_B^0 x_B$$

### 3.2.1 Ideal solutions

A solution that obeys Raoult's law at all concentrations and at all temperatures is called an ideal solution. Two liquids A and B on mixing form an ideal solution. If

- (i) The molecules of A and B have similar structure and polarity, and
- (ii) The intermolecular attractions between A and A, B and B, and A and B are alike.

Thermodynamically, ideal solutions are those in which there is no volume change ( $\Delta V_{mix} = 0$ ) and enthalpy change ( $\Delta H_{mix} = 0$ ) when two liquids A and B are mixed. Thus the characteristics of an ideal solution are:

- (i) It must obey Raoult's law
- (ii)  $\Delta H_{mix} = 0$
- (iii)  $\Delta V_{mix} = 0$

Some examples of nearly ideal liquid mixtures are

- (i) Ethylene bromide and ethylene chloride
- (ii) n-hexane and n-heptane
- (iii) Benzene and toluene
- (iv) n-butyl chloride and n-butyl bromide
- (v) Carbon tetrachloride and silicon tetrachloride.

### 3.2.2 Non Ideal Solutions

Many of the completely miscible liquid pairs form non-ideal solutions. These solutions do not obey Raoult's law. They either show positive deviation (When the vapour pressure of the solution is higher than that of an ideal solution of the same concentration) or negative deviation (When the vapour pressure of the solution is lower than that of an ideal solution of the same concentration) from Raoult's law. In such solutions,

$$P_A = p_A^0 x_A$$

**and**  $P_B = p_B^0 x_B$

When the components of a non-ideal solution are mixed, a considerable change in volume and enthalpy is noticed. Thus the characteristics of non-ideal solutions are as follows:

(I) They do not obey Raouls law

(II)  $\Delta V_{mix} \neq 0$  etc.

$\Delta H_{mix} \neq 0$

Examples of non-ideal solutions showing positive and negative deviations are given in Table 3.1.

Table 3.1. Liquid Pairs Showing Deviation from Raoult's Law

Positive deviation	Negative deviation
H <sub>2</sub> O + C <sub>2</sub> H <sub>5</sub> OH	H <sub>2</sub> O + HCl
CH <sub>2</sub> Cl <sub>2</sub> + C <sub>2</sub> H <sub>5</sub> OH	H <sub>2</sub> O + HNO <sub>3</sub>
C <sub>2</sub> H <sub>5</sub> OH + C <sub>2</sub> H <sub>5</sub> Cl	H <sub>2</sub> O + H <sub>2</sub> SO <sub>4</sub>
CH <sub>2</sub> Cl <sub>2</sub> + CS <sub>2</sub>	CH <sub>2</sub> Cl <sub>2</sub> + CHCl <sub>3</sub>

Let us work out an example illustrating the application of Raoult's law.

### Example 3

Two liquids A and B form an ideal solution at 300 K. The vapour pressure of a solution containing 1.0 mol of A and 2.0 mol of B at 300 K is  $2.0 \times 10^5$  Pa. When one more mole of B is added to the solution, the vapour pressure of the solution is  $2.1 \times 10^5$  Pa. Calculate the vapour pressures of A and B in the pure state.

### Solution

According to Eq. 10.11, total vapour pressure of the solution is given by,

$$p = p_A^0 x_A + p_B^0 x_B$$

Substituting the values, we get

$$2.0 \times 10^5 \text{ Pa} = p_A^0$$

$$\text{or } 2.0 \times 10^5 \text{ Pa} = p_A^0 \frac{1.0}{3.0} + 2.0 p_B^0 \frac{2.0}{3.0}$$

$$\text{or } p_A^0 + 2.0 p_B^0 = 6.0 \times 10^5 \text{ Pa} \quad (1)$$

$$\text{Also } 2.1 \times 10^5 \text{ Pa} = p_A^0$$

$$\text{or } p_A^0 + 3.0 p_B^0 = 8.4 \times 10^5 \text{ Pa} \quad (2)$$

From (1) and (2).

$$p_B^0 = 2.4 \times 10^5$$

$$p_A^0 = 1.2 \times 10^5 \text{ Pa}$$

### Exercise 1

0.100 mol of acetone and 0.100 mol of chloroform are mixed at 308 K. At this temperature, the total vapour pressure of the solution is  $3.47 \times 10^4$  Pa. The vapour pressures of pure acetone and pure

chloroform at 308 K are  $4.60 \times 10^4$  Pa and  $3.92 \times 10^4$  Pa, respectively. Verify whether this solution is ideal or not.

### 3.3 Ideal Solutions of Volatile Solutes

Now let us consider a situation in which the two constituents of an ideal solution are both volatile. For such a composition, the vapour pressure of each constituent will be lowered in accordance with Raoult's law. For two liquids A and B, at a given temperature.

$$P_A = N_A p_A^0$$

$$P_B = N_B p_B^0$$

The vapour pressure of the solution will then be the sum of the vapour pressures of the two constituents. Thus.

$$P_{\text{solution}} = P_A + P_B$$

$$N_A p_A^0 + N_B p_B^0$$

### 3.4 Raoult's Law Curves

According to Raoult's law, the partial vapour pressure of each component A and B of an ideal solution is given by Eqs. 3.1 and 3.2. The partial vapour pressure of each component can be plotted against its mole fraction in the liquid phase. Such vapour pressure curves for an ideal solution are shown in Fig. 3.1.

Completely miscible liquid pairs may be ideal or non-ideal. Ideal solutions obey Raoult's law. Non-ideal solutions either show positive or negative deviation from Raoult's law. Ideal solution can be separated into two fractions by fractional distillation – one, a pure component and, another, a constant boiling azeotropic mixture.

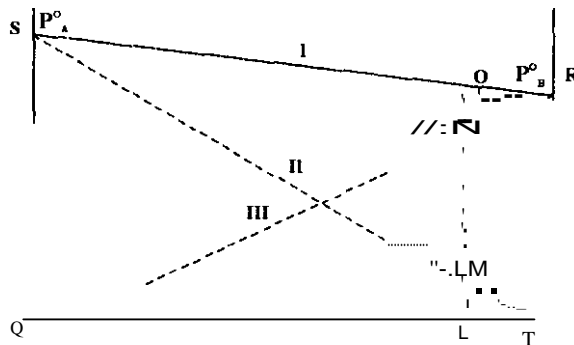

Fig. 3.1: Vapour pressure curves for ideal solution

Curve 1: Total vapour pressure of solution

Curve 2: Partial vapour pressure of A,  $P_A = p_A^0 X_A$

Curve 3: Partial vapour pressure of B,  $P_B = p_B^0 X_B$

The dotted line shows the variation of vapour pressures of the components A and B with mole fraction in the liquid phase. Thus, curve QR (III) indicates the variation of partial vapour pressure of B with its mole fraction in the liquid solution and curve ST (II) indicates the variation of partial vapour pressure of A with its mole fraction in the liquid solution. The points, S and R, represent the vapour pressures ( $P_A^0$  and  $P_B^0$ ) of the pure components A and B respectively. The variation of total vapour pressure with respect to the mole fraction of B in the liquid solution is given by the curve SR (1).

From Fig. 3. I. it can be seen that the vapour pressure of an ideal solution of composition L is given by the sum of the partial vapour pressure of A and the partial vapour pressure of B (or  $OL = ML + NL$ )

### Vapour Pressure curves of solutions showing positive deviation

If the molecular interactions between A and B are weaker than the A-A or B-B molecular interactions, then the escaping tendency of the molecules of A and B from the solution becomes more than that from the pure liquids. As a result, the vapour pressure of the solution will be greater than that of an ideal solution of the same composition. Such solutions are said to show the positive deviation from Raoult's law. Mathematically,

$$P_A > p_A^i$$

$$P_B > p_B^i$$

$$P > p_A + p_B$$

In Fig 3.2 the dotted lines are theoretical curves showing the ideal behaviours, the solid lines are curves drawn as per experimental values and show positive deviation from behaviour. When ethanol and cyclohexane are mixed, the curves shown in Fig. 3.2 are obtained.

In ethanol, there is a strong intermolecular hydrogen bonding. When cyclohexane is added to it, the cyclohexane molecules get in between the ethanol molecules thereby decreasing the intermolecular interactions. During the formation of such a solution, heat is observed and there is a slight increase in volume.

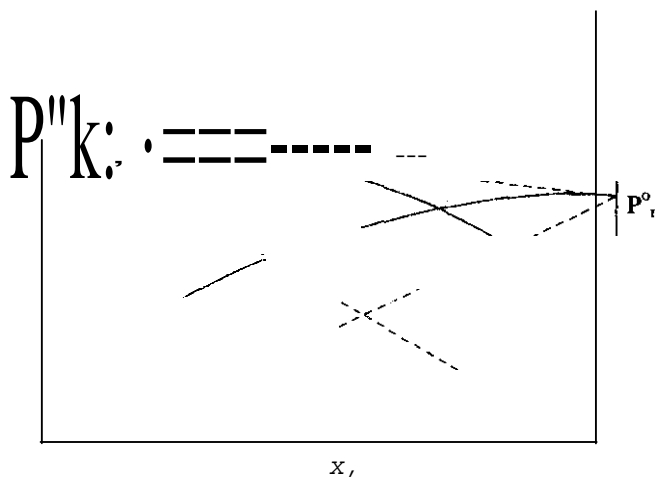

Fig. 3.2: Curves showing positive deviation from Raoult's law

Vapour pressure curves of solutions showing negative deviation

If the intermolecular forces between A and B are stronger than those of A-A and B-B, the solution formed by mixing A and B shows negative deviation from Raoult's law. Due to stronger A-B interactions, the escaping tendency of A and B from the solution becomes less than that from the pure liquids. The vapour pressure of such a solution will be less than an ideal solution of the same composition. This behaviour is shown in Fig. 3.4.

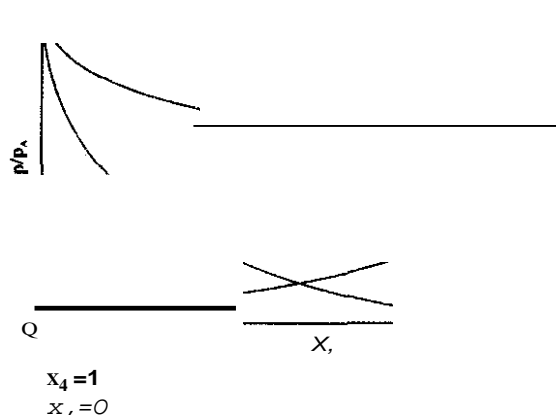

Fig. 3.4: Curves showing negative deviation from Raoult's law

The dotted lines are the theoretical curves representing the ideal behaviour, whereas the solid lines are the curves drawn as per experimental values and show negative deviation from ideal behaviour. When acetone and chloroform are mixed, they form hydrogen bonds with each other. As a result the intermolecular attractions between acetone and chloroform become stronger. The tendency of the molecules to escape from the solution thus decreases. The vapour pressure therefore decreases. During the formation of such solutions, heat is evolved and there is a slight decrease in volume.

#### 4.0 Conclusion

We have learnt in this Unit about the solutions and their various properties. A solution is a homogeneous mixture of two or more substances. Solutions can be formed in all the three phases, namely, solid, liquid and gaseous. Solutions can be divided into nine types depending upon the physical state of the solute and the solvent. A solution which cannot dissolve more amount of a solute at a particular temperature, is said to be saturated.

#### 5.0 Summary

Specifically what you have learnt can be summarized as follows:

- An ideal binary solution is one which can be formed from two constituents with no evolution or absorption of heat and whose volume is the sum of the volumes of each of the constituents.
- Raoult's law states that the partial vapour pressure of any volatile component in a solution is equal to the product of the vapour pressure of the pure constituent and its mole fraction in the solution.
- Ideal solutions obey Raoult's law while non-ideal solutions do not obey.

## 6.0 Tutoh-Marked Assignment

1. State whether the following statements are true or false:
  - (i) Raoulf's law for ideal solutions is applicable both to the liquid and the vapour phase compositions.
  - (ii) The solubilities of all substances, i.e. solids, liquids and gases, in liquids increase with rise in temperature.
2. Which of the following liquid pairs can be completely separated into its pure components?"

(I)	Ethanal	water
(II)	Ethylene chloride	ethylene bromide
(III)	Nitric acid	water
(IV)	Acetone	carbon disulphide
(V)	Carbon tetrachloride	water

## Unit 4: **Binary Liquids Solutions- 2**

### **Table of Contents**

	<b>Page</b>
L0 Introduction	132
2.0 Objectives	132
3.1 Vapour Pressure Variation with Liquid and Vapour Composition	132
3.2 Boiling Point Diagrams	134
4.0 Concluston	139
5.0 Summary	139
6.0 Tutor-MarkedAssignment	139



## 1.0 Introduction

In Module 4, unit 2, we considered solutions of solids and gases in liquids. In Module 4, Unit 3 we learnt about completely miscible liquids and we discussed Raoult's law. This Unit will be devoted to completely miscible liquids as well but we will be concentrating on vapour pressure variation and boiling point diagrams. We will emphatically examine ideal solution of different composition.

## 2.0 Objectives

By the end of this Unit, you should be able to

- Describe the effect of composition on the vapour pressure of the completely miscible liquid system.
- Explain the effect of composition on the boiling points of solutions.
- Recognise the variations in boiling points of solutions.

## 3.1 Vapour Pressure Variation with Liquid and Vapour Composition

Consider a solution containing one mole of benzene and one mole of toluene so that the mole fraction of each component in the solution is 0.5. The vapour pressures of pure benzene and toluene at 298 K are  $1.25 \times 10^4$  Pa and  $3.70 \times 10^3$  Pa, respectively. According to Raoult's law,

$$P_{C_6H_6} = p_{C_6H_6}^* \cdot x_{C_6H_6} = (1.25 \times 10^4 \text{ Pa}) \times 0.5 = 6.25 \times 10^3 \text{ Pa}$$

$$P_{C_7H_8} = p_{C_7H_8}^* \cdot x_{C_7H_8} \\ = (3.70 \times 10^3 \text{ Pa}) \times 0.5 \\ = 1.85 \times 10^3 \text{ Pa}$$

$$P_{\text{total}} = (6.25 \times 10^3 \text{ Pa}) + (1.85 \times 10^3 \text{ Pa}) = 8.10 \times 10^3 \text{ Pa}$$

Mole fraction of benzene in the vapour phase

$$\frac{6.25 \times 10^3 \text{ Pa}}{8.10 \times 10^3 \text{ Pa}} = 0.77$$

Mole fraction of toluene in vapour phase

$$\frac{1.85 \times 10^3 \text{ Pa}}{8.10 \times 10^3 \text{ Pa}} = 0.23$$

It is quite interesting to compare the mole fractions of benzene in the vapour and liquid phase solutions. From the calculations above, the mole fraction of benzene (0.77) in the vapour phase is more than that in the liquid phase (0.5). Again, the mole fraction of toluene in the vapour phase (0.23) is less than that in the liquid phase (0.5). Bearing in mind that benzene is more volatile than toluene, we can arrive at the following generalization which is one of the forms of Raoult's rule: The mole fraction of a more volatile component in an ideal solution is more in the vapour phase than in the liquid phase.

For the purpose of comparing the compositions of the solutions in the liquid and the vapour phases at a given total pressure, it is worth drawing curves of the types I and II shown in Fig. 4.1. Curve I shows the variation of total vapour pressure with respect to the mole fraction in the liquid phase. Similarly, curve II shows the variation of the total vapour pressure with respect to the mole fraction in the

vapour phase. The line MN is called a tie line and it gives us the composition of the solution in the liquid and vapour phases in equilibrium at a particular total vapour pressure.

Note that the vapour phase curve II lies below the liquid phase curve I. This is due to the fact that the vapour phase is richer in the more volatile component than the liquid phase and this has been explained in the beginning of this section.

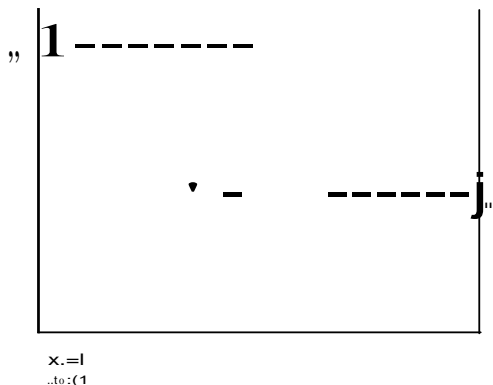

Fig. 4.1: Liquid and vapour composition curves for an ideal solution

The curves I and II of Fig. 4.1 are obtained in the case of solutions obeying Raoult's law. In the case of solutions showing positive deviation from Raoult's law, the liquid and vapour composition curves are of the type shown in Fig. 4.2. Note that there is a maximum point M, where both the liquid and vapour phases have the same composition.

In the case of a solution showing negative deviation from Raoult's law, the liquid and vapour composition curves are of the type shown in Fig. 4.3. Note that the curves meet at the minimum point M where both the liquid and vapour phases have the same composition.

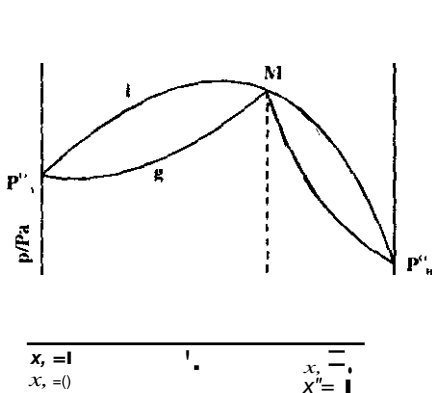

Fig. 4.2

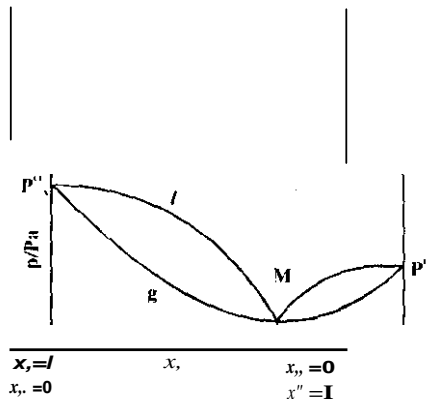

Fig. 4.3

So far we studied the effect of composition on the vapour pressure of the completely miscible liquid system. In the next section, we will study the effect of composition on the boiling points of solutions. Such studies are helpful in understanding some of the aspects of separation of components from a binary liquid mixture. In particular, we will study the principles of fractional distillation and azeotropic distillation.

**Exercise ■**

In a binary solution obeying Raoult's law, can the liquid and the vapour phases have the same composition?

**3.2 Boiling Point Diagrams**

Let us consider a binary mixture consisting of two liquids A and B which are completely miscible with each other. On heating under constant pressure, say, under atmospheric pressure, it will start boiling when the total pressure becomes equal to the atmospheric pressure. If  $P$  represents the atmospheric pressure, then the condition for boiling is

$$P = P_A + P_B$$

Where  $P_A$  and  $P_B$  are the partial pressures of the two components A and B. Since different compositions of a solution have different vapour pressures, the various solutions will not reach a total vapour pressure equal to the atmospheric pressure at the same temperature. Hence, the solutions of different compositions will boil at different temperatures. In general solutions of low vapour pressure will boil at temperatures higher than those of solutions for which the vapour pressures are high. It is because solutions of high vapour pressure can have the total pressure equal to the atmospheric pressure at relatively lower temperatures as compared to solutions for which vapour pressures are low. Hence, it is possible to draw temperature-composition diagrams, which will correspond to the three general types of vapour pressure-composition diagrams. First we shall study boiling point-composition diagrams of an ideal solution.

Type 1: Distillation of an ideal solution

Let us consider a binary mixture of liquids A and B obeying Raoult's law

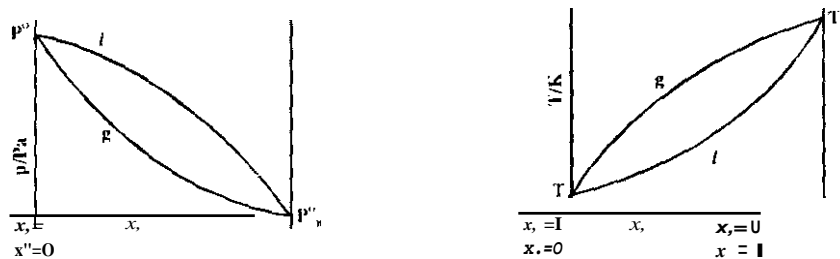

Fig. 4.4: (a) Vapor pressure and vapour composition plotted against vapour pressure at constant temperature for an ideal solution. (b) Boiling point and vapour composition plotted against temperature at constant pressure for an ideal solution

Let the vapour pressure of pure A be higher than that of pure B (Fig. 4.4a).

Consequently at constant pressure, the boiling point of A ( $T_A$ ) will be lower than that of B ( $T_B$ ). We can get an idea about the relative composition of the vapour phase over a solution using Raoult's rule. Although you have studied one of the forms of this rule in the last section, this rule can also be stated as follows:

In the distillation of a binary liquid mixture, vapours coming out will be richer in that component whose addition to the liquid mixture causes an increase in vapour pressure.

In other words, as compared to the liquid mixture, the vapour is richer in the more volatile component. In the liquid mixture that we have taken, A is more volatile than B. Hence, the vapour composition at any temperature must be closer to A than the corresponding liquid composition. In other words, in the composition against temperature plot, the vapour composition curve must lie above the liquid composition curve as shown in Fig. 4.4b. Note the difference in the relative positions of the liquid and vapour curves between Fig. 4.4 a and b.

Using Fig. 4.5 we can understand the various stages in the separation of the components of an ideal solution.

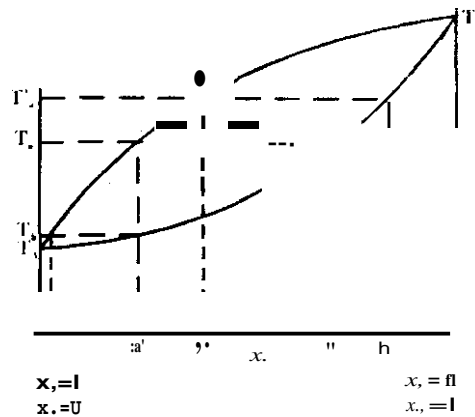

**Fig. 4.5: Separation of the components in an ideal solution at constant pressure**

Let us start with a solution of A and B having liquid composition,  $a$ . If this solution is heated, it boils at a temperature,  $T_a$ , when its vapour pressure is equal to the atmospheric pressure. At  $T_a$ , let the composition of the liquid and the vapour be  $a$  and  $a'$ , respectively. Since A is more volatile than B, vapours of composition of  $a'$  will be richer in A than liquid of composition  $a$ . Assume that these vapours coming out of the liquid are collected and condensed to obtain the liquid. The liquid so obtained by cooling the vapours of composition  $a'$  also will have the same composition. As the vapours of composition  $a'$  (which are richer in A than the liquid of composition  $a$ ) are removed, the composition of the residual liquid changes to  $b$ : note that the liquid of composition  $b$  is richer in B than the liquid of composition  $a$ . The boiling point of this residual liquid ( $T_b$ ) is higher than  $T_a$ . At this temperature, vapours coming out of the boiling tube have composition  $b'$ . Again the vapours of composition  $b'$  are richer in A than the liquid of composition  $b$ . The vapours on condensation give liquid of composition  $b'$ . On the removal of vapours, the boiling point rises and the residual liquid becomes richer in B. So, if this process is continued, the boiling point of the residual solution will rise from initial boiling point  $T_a$  towards the boiling point of pure B,  $T_B$ . At the same time, the residue will become richer in B and if the process is repeated continuously, a final residue of pure B can be obtained.

Let us now consider the liquid  $a'$  obtained by cooling the vapours coming out at  $T_a$ . If this liquid is heated, it boils at  $T_a''$  and the vapours coming out will have the composition  $a'$ , which on condensation

give the liquid of same composition. It is obvious from Fig. 4.5 that liquid of composition  $a'$  is richer in A than that of composition  $a$ . If the process of distillation and condensation is continued, we can obtain vapours of pure A. So, we can separate mixtures of type I into a residue of the less volatile component (B) and a distillate of more volatile component (A). The separation is practically more efficient using fractional distillation.

#### Fractional Distillation and Theoretical Plates

The several stages described for the separation of ideal solution into its pure components can be carried out in the continuous process which is called fractional distillation. In fractional distillation, the **process of successive vaporization and condensation is carried out in a fractionating column**. Let us understand it by taking benzene and toluene liquid mixture, having the composition (Fig. 4.6).

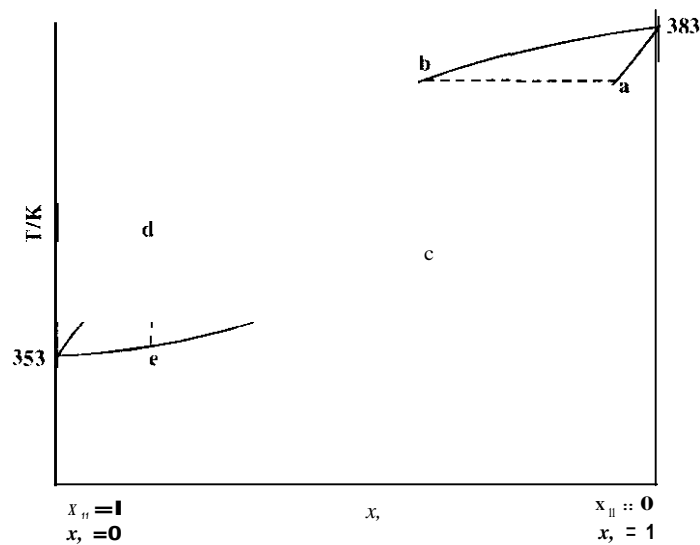

Fig. 4.6: Liquid and vapour compositions of benzene and toluene:  $x_B$  and  $x_T$  refer to mole fractions of benzene and toluene

The vapours in equilibrium are richer in the more volatile component, benzene, and will have the composition  $b$ . This vapour may be condensed by lowering the temperature along the line  $be$ . If a small fraction of this condensate is vaporized, the vapours formed will have composition  $d$ . Finally, by repetition of vaporization and condensation, a vapour fraction rich in benzene can be obtained. Here, each vaporization and condensation represented by the path  $abcde$  corresponds to an idealized process in which only a small fraction of the condensate is re-vaporized. Practically, the fractionating column shown in Fig. 4.7 is more efficient.

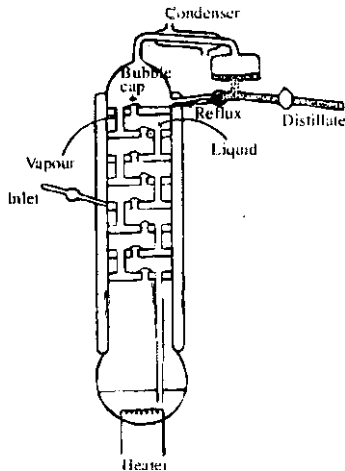

Fig 4.7: Fractionating column

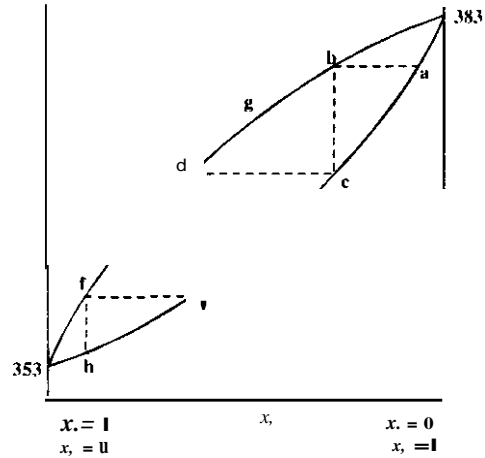

Fig. 4.8: Fractionation of the components:  $X_B$  and  $X_T$  stand for mole fractions of benzene and toluene

Each layer of the liquid on the plates of the column is equivalent to the boiling liquid in a distillation flask, and the liquid on the plate next above it is equivalent to the liquid condensed from the vapours. The vapour passes upwards through bubble caps, where it is partially condensed from the vapours. The vapour passes upwards through bubble caps, where it is partially condensed into the liquid and mixed with it. Part of the resulting solution is vaporized in the process and is condensed in the next higher layer, while part of the liquid overflows and runs down the tube to the next lower plate.

The efficiency of a column is expressed in terms of the equivalent number of **theoretical plates**. The number of theoretical plates in a column is equal to the number of successive infinitesimal vaporizations required to give the separation to the desired extent. The number of theoretical plates in a column is equal to the number of successive infinitesimal vaporizations required to give the separation to the desired extent. The number of theoretical plates in a distillation column, under actual operation, may be obtained by using Fig. 4.8. This can be done by counting the number of equilibrium vaporizations required to achieve the separation of the components to the required extent. Suppose that in distilling a solution of benzene and toluene of composition  $a$  with a certain distillation column, it is found that distillate of composition  $h$  is obtained (Fig. 4.8). Such a distillation is equivalent to three simple vaporizations and condensations as indicated by steps  $abc$ ,  $cdc$  and  $efh$ . Since the distilling pot itself corresponds to one theoretical plate, the column has two theoretical plates.

### Type II: Distillation of a Solution Exhibiting Positive Deviation

Let us now take up the separation of a mixture of liquids showing positive deviation from Raoult's law. Fig. 4.9 represents the boiling point-composition diagram of such systems. Note that this system has a minimum point  $C$  where the liquid and vapour phases have the same composition.

Let us consider the distillation of a solution of composition  $a$ , which is between  $X$  and  $C$ . The vapours coming off will have the composition  $p$  and will be richer in  $B$  than the liquid  $a$ . Because of this, the composition of the residue will shift towards  $A$ . Hence, the residue will have to boil at a higher temperature than the original solution  $a$ . If the distillation is continued (through the steps  $pqr$ ,  $qrs$ , etc.), vapours of composition  $C$  will eventually be obtained. Such vapours when condensed and redistilled will again yield the vapours of composition  $C$  i.e., vapours will have the same composition as that of the liquid solution. Hence, no further separation is possible by distillation. Because of this, the liquid of composition  $C$  is called the constant boiling mixture.

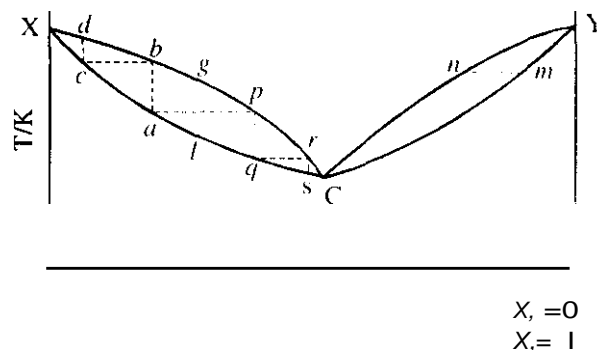

Fig. 4.9: Boiling point-composition diagram of a liquid mixture showing positive deviation

Thus a mixture having a composition between X and C can be separated by fractional distillation only in a residue of pure A and a final distillate of composition C, but pure B cannot be recovered

On the other hand, if a solution of composition **m**, which is between C and Y is distilled then the vapours of composition **n** which are coming out will be richer in A than the original solution. Hence, on repeated distillation, the residue will tend towards pure B, while the distillate will tend towards C. Such solutions on complete distillation will yield pure B in the vapour form. That is, repeated distillations and condensations of liquid **a**, leads to a liquid residue of composition D and vapours of pure B

A mixture of composition **m** between D and X will yield on distillation a vapour of composition **n** richer in A than the solution. Here again, the residue will shift towards D. By redistillation of the condensate, the vapours will tend towards pure A. Finally, we will have a residue of composition D and a distillate of pure A.

In general, we can separate a liquid mixture showing negative deviation into a residue of composition D, the constant maximum boiling mixture, and a distillate of either pure A or pure B depending on whether the starting composition is between X and D or D and Y. But D cannot be separated further by distillation.

The constant boiling mixtures having composition C in type II solutions (Fig. 4.10) and composition D in type III solutions (Fig. 4.11) are called azeotropes (i.e., liquids boiling unchanged). They resemble pure compounds in their boiling behaviour. However, changes in pressure produce changes in the composition as well as the boiling point of the azeotropes (See Table 4.1). The azeotropes are not chemical compounds but are rather mixtures resulting from the interplay of intermolecular forces in solution. Table 4.2 lists some azeotropic mixtures along with their point of a liquid.

**Table 4.1: Pressure Dependence of H<sub>2</sub>O-HCl Azeotropes**

Pressure/10 <sup>5</sup> Pa	% HCl	B.P./K
0.658	20.92	370.7
0.921	20.36	379.5
1.00	20.22	381.7
1050	20.16	<b>383.1</b>

Table 4.2: Azeotropes with Minimum Boiling Points (at 10<sup>5</sup> Pa)

Component I	B.P./K of I	Component II	B.P./K of II	Composition: Mass % of I	B.P./K
	K		K		
H <sub>2</sub> O	373.1	C <sub>2</sub> H <sub>5</sub> OH	351.4	4.50	351.3
H <sub>2</sub> O	373.1	CH <sub>2</sub> Cl <sub>2</sub>	352.7	11.30	346.5
CCl <sub>4</sub>	349.9	CH <sub>3</sub> OH	337.8	9.44	328.8
CS <sub>2</sub>	319.4	CH <sub>3</sub> COCH <sub>3</sub>	329.6	67.00	312.4
CHCl <sub>3</sub>	334.3	CH <sub>3</sub> OH	337.8	87.40	326.5

#### Exercise 2

Can azeotropes be separated into pure components by fractional distillation? Explain.

#### Exercise 3

How many theoretical plates are there as per Fig. 4.9?

## 4.0 Conclusion

We have learnt in this Unit more about the completely miscible liquids and their various properties. The effect of composition on the vapour pressure and boiling points has been discussed. The processes involved in fractional distillation were also stated.

## 5.0 Summary

Specifically what you have learnt can be summarized as follows:

- The vapour phase is richer in the volatile component of an ideal solution than the liquid phase.
- Ideal solutions obey Raoult's law while non-ideal solutions do not obey.
- o Fractional distillation involves the process of successive vaporization and condensation.

## 6.0 Tutor-Marked Assignment

1. State whether the following statements are true or false.
  - (i) Azeotropes are compounds and not mixtures
  - (ii) Molality is the number of moles of solute present in one kilogram of the solvent.
2. State Raoult's rule.
3. An azeotropic mixture of hydrochloric acid and water contains 20.2% hydrochloric acid. Calculate its molality



## Unit 5: Partially Miscible Liquids

### Table of Contents

	<b>Page</b>
1.0 Introduction	141
2.0 Objectives	141
3.1 Partially Miscible Liquid Systems	141
3.2 Effect of Impurities on CST Values	143
<b>3.3 Immiscible Liquid Pairs</b>	<b>144</b>
3.4 Concept of Distribution Law	146
4.0 Conclusion	148
5.0 Summary	148
6.0 References and Other Resources	148
7.0 Tutor-Marked Assignment	148

## 1.0 Introduction

In Module 4, Unit 3, we have discussed the completely miscible liquid systems. In this Unit, we shall study the partially miscible and completely immiscible liquid systems. We shall explain Nernst distribution law and use it in calculating the amount of the substances left unextracted after a given number of extraction. This will help us in understanding the principle of extraction by the solvents. In the next Unit, you shall study some of the aspects of dilute solutions.

## 2.0 Objectives

By the end of this Unit, you should be able to:

- Describe the effect of temperature on the miscibility of partially miscible liquid pairs.
- Define consolute temperature.
- Describe the effect of impurities on the consolute temperature.
- Explain the principle of steam distillation.
- Define distribution law.

## 3.1 Partially Miscible Liquid Systems

Some liquid pairs do not give homogeneous solutions at all compositions. Such liquid pairs are said to be partially miscible liquids. However, due to increased solubility with increase or decrease in temperature, these may become completely miscible. We can explain such a system of liquids phenol and water. When a very small amount of phenol is added to water at room temperature, it dissolves completely to give a single phase. However, when the addition of phenol is continued, a point is reached when phenol does not dissolve anymore. At this point, two phases, i.e., two liquid layers are formed—one consisting of water saturated with phenol and the other containing phenol saturated with water. Further addition of phenol causes water to shift from water-rich layer to phenol-rich layer. If addition of phenol is continued, a point is reached when phenol acts as a solvent for all the water present and the two phases merge with each other to form a single phase, i.e., solution of water in phenol. Thus, on shaking equal volumes of phenol and water, two layers are formed— one of phenol in water and the other of water in phenol.

It has been experimentally found that at constant temperature, the composition of the two layers, although different from each other, remains constant as long as the two phases are present. Such solutions of different compositions co-existing with each other are termed as conjugate solutions. The addition of small amounts of phenol or water changes the volume of the two layers and not their compositions. As the temperature is increased, the behaviour remains the same except that the mutual solubility of the two phases increases. When the temperature reaches 338.8 K, the composition of the two layers becomes identical and thereafter the two liquids are completely miscible: i.e., at and above 338.8 K, phenol and water dissolve in each other in all proportions and yield only a single liquid layer on mixing. The variation of mutual solubility of water and phenol with temperature is shown in Fig. 5.1.

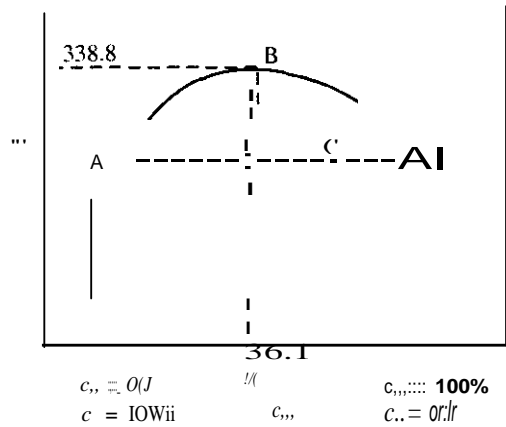

Fig. 5.1: Phenol-water system:  $c_1$  stands for composition of phenol and  $c_2$  for composition of water

At a particular temperature, say 325 K, point A represents the composition of water-rich layer and point A' represents the composition of phenol-rich layer in equilibrium with A. Between these compositions, all mixtures will yield two layers of compositions A and A'. Outside these compositions, the two liquids are soluble mutually at 325 K. Similar behaviour is seen at other temperatures below 338.8 K. We can conclude that the dome-shaped area represents the range of existence of two liquid phases and the area outside the dome represents a single liquid phase. The temperature corresponding to the point B, i.e., the temperature at which the solubility becomes complete is called the critical solution temperature or the consolute temperature. Since the mutual solubility of phenol and water increases with rise in temperature, the critical solution temperature (CST) lies well above the room temperature. Hence, such liquid systems are said to possess an upper critical solution temperature or upper consolute temperature. Thus, the critical solution temperature for phenol-water system is 338.8 K. At and above 338.8 K, phenol and water are completely miscible with each other in all proportions. At this temperature, the composition of the solution is 36.1% phenol and 63.9% water. At any point C, the relative weights of the two separate layers is given by the relationship,

Mass of the first layer      A, C  
 Mass of the second layer    A' C

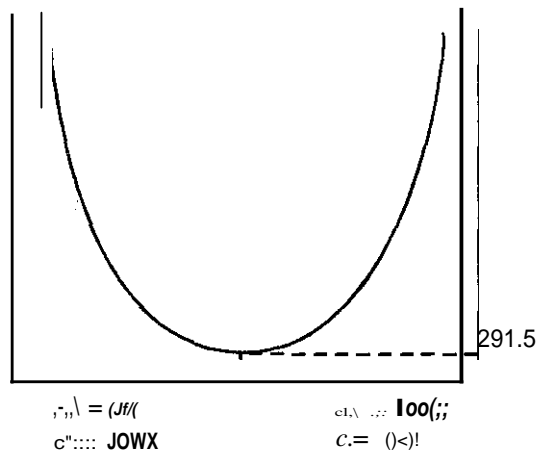
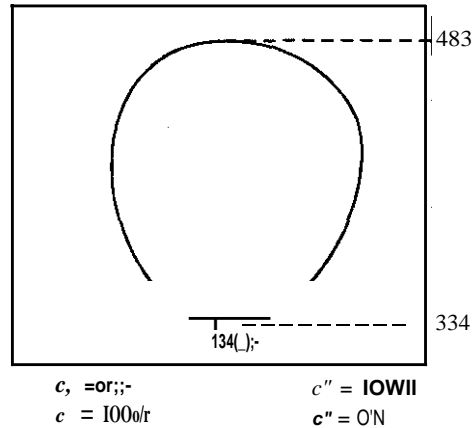

Fig. 5.2: Triethylamine-water system:  $c_1$  stands for the composition of triethylamine

There are some liquid pairs (e.g. triethylamine-water) for which mutual solubilities decrease with rise in temperature. As the temperature is decreased, the mutual solubilities increase and below the consolute temperature, the two liquids become miscible in all proportions. Such systems possess lower consolute temperatures. The variation of mutual solubility of triethylamine and water with temperature is shown in Fig. 5.2. Above 291.5 K, on shaking triethylamine and water, two layers are formed; but below 291.5 K, triethylamine and water are completely miscible with each other in all proportions.



**Fig. 5.3:** Nicotine – Water Systems:  $C_v$  stands for the composition of nicotine

Some liquid pairs, e.g., nicotine and water, show both the upper and lower consolute temperatures. These liquid pairs are completely miscible above a certain temperature (upper consolute temperature) and below a certain temperature (lower consolute temperature). The variation of mutual solubilities of nicotine and water with temperature is shown in Fig. 5.3. Within the enclosed area, the liquids are only partially miscible while outside the enclosed area, they are completely miscible. The composition corresponding to both the upper and the lower consolute temperatures is the same, i.e., 34% nicotine.

Table 5.1 lists the consolute temperatures of some liquid pairs. The two components are denoted as A and B.

**Table 5.1: Consolute Temperatures of Some Liquid Pairs**

Components		Consolute Temperature	
A	B	Upper	Lower
Aniline	Phenol	338.8	-
Methanol	Hexane	333.6	-
Water	Carbon disulphide	323.5	-
Water	Diethylamine	-	316
Water	Triethylamine	-	291.5
Glycerol	Nicotine	483	334
	m-Toluidine	393	280

### 3.2 Effect of Impurities on CST Values

The presence of an impurity, dissolved in one or both of the phases, changes the CST values as well as the liquid phase composition at CST. Substances soluble in only one of the liquids raise the upper CST

and lower the lower CST For example, one percent solution of sodium chloride raises the upper CST of phenol-water system by 12°. About 0.12 molar solution of naphthalene (insoluble in water) in phenol raises the upper CST of phenol-water system by 30°. Substances soluble in both liquids tend to lower the upper CST and raise the lower CST. For example, sodium oleate is soluble in both water and phenol. Addition of 1% solution of sodium Oleate to phenol-water system lowers the CST value by 45°.

As seen above, the presence of small amounts of impurities produces a very large change in the CSI values. The change in CST values is usually a linear function of concentration of impurities. Traces of water present in alcohol are estimated by measuring their CST values with cyclohexane.

As mentioned above, a very small amount of sodium oleate lowers the CST value of Phenol-water system considerably. Thus, by making phenol completely miscible with water (by adding appropriate amounts of sodium oleate), lysol-like disinfectants are made.

### Exercise 1

Give one example each for liquid pairs with,

- (a) Lower critical solution temperature
- (b) Upper critical solution temperature
- (c) Both upper and lower critical solution temperatures.

### Exercise 2

What is the effect of adding 0.1 molar KCl on the CST of phenol-water system?"

### Exercise 3

What happens when potassium carbonate is added to a solution of water and alcohol?

## 3.3 Immiscible Liquid Pairs

In Section 3.1, we studied the partially miscible liquid pairs. In this section, we shall discuss the characteristics of the completely immiscible liquid pairs. We should, however, understand that there is always some solubility of a substance into the other. But this is so low that we can call it insoluble or completely immiscible.

According to Raoult's law, the vapour pressure of a liquid is lowered on the addition of another liquid, if the latter is soluble in the former. Otherwise, the vapour pressure of each component remains unaffected and each liquid exerts its own vapour pressure independent of the other. Thus, when two completely immiscible liquids A and B are mixed, the total vapour pressure ( $p$ ) above the mixture will be the sum of the vapour pressures of the pure liquids at that temperature. i.e.,

$$p = p_A^0 + p_B^0 \dots \dots \dots (3.2)$$

Where  $p_A^0$  and  $p_B^0$  are respectively, the vapour pressures of pure A and B. It is known that a system starts boiling when its total vapour pressure becomes equal to the atmospheric pressure. The mixture of immiscible liquids A and B will thus start boiling at a temperature (T) at which,

$$p_A^0 + p_B^0 = \text{atmospheric pressure.} \quad \dots\dots(3.3)$$

This temperature will be lower than the normal boiling point of A or B. The mixed vapours thus obtained and condensed will have a composition dependent on the partial pressures of A and B at temperature T. Since the number of moles of each component present in the vapour phase is proportional to its vapour pressure, the mole ratio of A to B ( $n_A/n_B$ ) in the condensate is given by

$$n_A/n_B = p_A^0/p_B^0 \quad \dots\dots (3.4)$$

If  $W_A$  and  $W_B$  are the masses of A and B in the condensate, and  $M_A$  and  $M_B$  their respective molar masses, then

$$n_A/n_B = \frac{W_A/M_A}{W_B/M_B} = \frac{W_A M_B}{W_B M_A} \quad \dots\dots (3.5)$$

$$\text{Or } \frac{W_A}{W_B} = \frac{p_A^0 M_A}{p_B^0 M_B} \quad \dots\dots (3.6)$$

6)

The fact, that a system of immiscible liquids starts boiling at temperatures less than the normal boiling points of both the liquids, is made use of in steam distillation. The steam distillation is a process of purifying organic liquids which have high boiling points and are immiscible with water. For purification by steam distillation, an impure compound

- (i) Must be immiscible in water
- (ii) Should not decompose at the temperature of steam
- (iii) Should have a fairly high vapour pressure at 373 K
- (iv) Should have non-volatile impurities.

For example, chlorobenzene has a boiling point of 405 K. A mixture of water and chlorobenzene distils at a constant temperature of 363.3 K, when the external pressure is  $9.8 \times 10^4$  Pa, by passing steam through it. Let us explain the procedure for purifying an organic liquid using steam distillation. The apparatus used for steam distillation is as shown in Fig. 5.4.

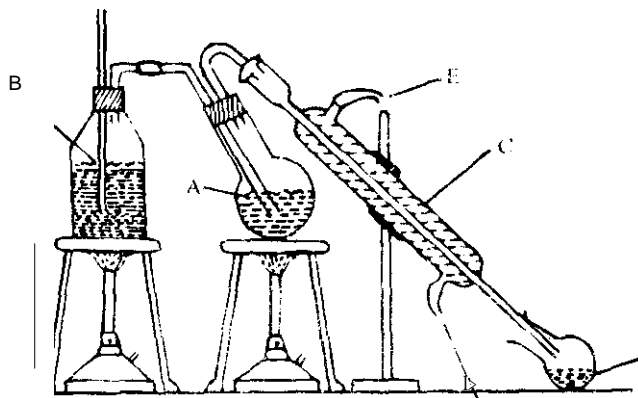

Fig. 5.4: Steam Distillation

The impure organic compound is taken in round-bottomed flask (A) and a small quantity of water is added. The flask must be kept in a slanting position to prevent the impure liquid from splashing up into the condenser. The flask A is then heated gently on a sand bath. Now steam from flask B is bubbled through the contents in the water condenser C. The condensate thus obtained in the flask F is a **mixture of water and the organic compound. This mixture can be separated by means of a separating funnel.**

Let us illustrate the application of Eq. 3.6.

### Example 1

A mixture of water and an organic liquid A, which is immiscible with water, distils at 368 K when the external pressure is  $1.00 \times 10^5$  Pa. The vapour pressure of water at 368 K is  $8.35 \times 10^3$  Pa. Calculate the relative molecular mass of A if the distillate contains 40% by weight of water.

### Solution

Let us represent the vapour pressures of pure water and the organic liquid A at 368 K as  $P_1^0$  and  $P_2^0$  respectively. At a total pressure of  $1.00 \times 10^5$  Pa, the liquid mixture boils, i.e.,

$$P_1^0 + P_2^0 = 1.00 \times 10^5 \text{ Pa}$$

At the distillation temperature,  $P_1^0 = 8.35 \times 10^3$  Pa

$$\text{Hence } P_2^0 = (1.00 \times 10^5 \text{ Pa} - 8.35 \times 10^3 \text{ Pa}) = 9.165 \times 10^4 \text{ Pa}$$

Using equation 3.6,

$$w_{\text{H}_2\text{O}} = \frac{P_1^0 \times M_2}{P_2^0 \times M_1}$$

But water is 40% by weight; hence we can write

$$\frac{40}{60} = \frac{8.35 \times 10^3 \text{ Pa}}{9.165 \times 10^4 \text{ Pa}} \times \frac{0.018 \text{ kg mol}^{-1}}{M_A}$$

$$\text{or } M_A = \frac{8.35 \times 10^3 \text{ Pa} \times 0.018 \text{ kg mol}^{-1} \times 60}{9.165 \times 10^4 \text{ Pa} \times \frac{40}{60}}$$

$$= 0.137 \text{ kg mol}^{-1}$$

The relative molecular mass of A is 137.

### Exercise 4

Why does a mixture of two immiscible liquids boil at a temperature which is lower than the boiling of any of the pure liquids?

## 3.4 Concept of Distribution Law

In this section, we shall discuss the effect of the addition of a solute to a pair of immiscible liquids. Water and carbon tetrachloride, for example, are practically immiscible with each other but iodine dissolves both in water and carbon tetrachloride. When iodine is added to a mixture of water and carbon

tetrochloride at a certain temperature, iodine distributes itself between the two immiscible layers- water and carbon tetrachloride. Let the concentration of iodine in water and carbon tetrachloride be  $c_1$  and  $c_2$ , respectively, at a particular temperature. Then we have.

$$\frac{c_1}{c_2} = K \quad \dots\dots\dots (3.7)$$

where  $K$  is a constant temperature.

If more of iodine is added to this system. it again distributes itself between the two layers. Now the concentration of iodine in both the layers will be more than that in the previous case. Let the concentrations be  $c'_1, c'_2$  is again equal to the constant,  $K$ , i.e.,

$$\frac{c'_1}{c'_2} = K \quad \dots\dots\dots (3.8)$$

It is evident that, in each case,  $I_2$  distributes itself between the two immiscible layers in such a way that the ratio of its concentration in the two layers is a constant at a certain temperature. It was pointed out by Nernst that the ratio,  $c'_1/c'_2$  is constant only when the solute exists in the same molecular form. i.e. the relative molecular mass of the solute is the same in the two layers. The Nernst distribution law may be stated as follows:

At a fixed temperature, a substance  $X$  distributes itself between the two immiscible solvents  $A$  and  $B$  in equilibrium with each other in such a way that the ratio of the concentrations of  $X$  in the two solvents is constant, provided that the solute  $X$  is in the same molecular state in both the solvents.

Mathematically,

$$K = \frac{\text{Concentration of X in solvent A}}{\text{Concentration of X in solvent B}} \quad \dots\dots\dots (3.9)$$

The constant  $K$  is called the *distribution or partition coefficient* of the solute between the two solvents. You can see from the data given in Table 5.2 that the value of  $K$  is fairly constant in dilute solutions. As the concentration increases, there is a deviation.

Table 5.2: Distribution of I, Between H<sub>2</sub>O and CCl<sub>4</sub>,

$I_2$ in [H <sub>2</sub> O] Mol dm <sup>-3</sup>	$I_2$ in [CCl <sub>4</sub> ] Mol dm <sup>-3</sup>	$K = \frac{[H_2O]}{[CCl_4]}$
3.22	2.745	$1.17 \times 10^{-1}$
5.03	4.29	$1.17 \times 10^{-1}$
7.63	6.54	$1.17 \times 10^{-1}$
11.5	10.1	$1.14 \times 10^{-2}$
13.4	11.96	$1.12 \times 10^{-2}$



K depends upon

- t Nature of the solute
- t Nature of the solvent and
- t Temperature

The distribution law can be derived taking into account thermodynamic considerations. This will be discussed at second level physical chemistry course.

#### 4.0 Conclusion

By and large, when two liquids are mixed, there are three possibilities, two of which are partially and completely immiscible liquid systems. We have discussed these two systems in this Unit. The miscibility of partially miscible liquid pairs is said to vary with temperature. The miscibility of some partially miscible liquid pairs e.g. phenol-water tends to increase with increase in temperature. Thus phenol-water system possesses an upper CST. Liquid pairs possess lower CST that is then mutual solubility) **decreases with increase in temperature.**

#### 5.0 Summary

At the end of this Unit, you have learnt that:

- The temperature at which a pair of partially miscible liquid becomes completely miscible is called critical solution temperature.
- t The temperature at which the solubility becomes complete is referred to as the critical solution temperature (CST) or the consolute temperature.
- t Below a certain temperature, some liquid pairs that possess lower CST are completely miscible.
- t The presence of an impurity in one or both of the phases changes the CST values.
- A pair of immiscible liquids boils at a temperature lower than the boiling points of any of the liquids
- Mathematically, the distribution law can be expressed as  
K concentration of X in solvent A/concentration of X in solvent B.

#### 6.0 References and Other Resources

IGNOU (1993). Solutions and Phase Equilibrium: Physical chemistry 3 CHE-04 pp 26-32 New Delhi.

#### 7.0 Tutor-Marked Assignment

1. Two liquids A and B are completely immiscible with each other. Their normal boiling points are  $T_a$  and  $T_b$  respectively, and  $T_a$  is less than  $T_b$ . The two liquids taken together will boil at  
A.  $T_a$ , B.  $T_b$   
C.  $T_a + T_b/2$  D. A temperature less than  $T_a$ ,  
E. None of these temperatures
2. An immiscible mixture of an organic liquid, A and water on steam distillation boils at 372 K at pressure of  $1.00 \times 10^5$  Pa. At this temperature the vapour pressure of water is  $9.60 \times 10^4$  Pa. The ratio of the mass of water to the mass of A in the distillate is 4:1. Calculate the relative molecular mass of liquid A.
3. Explain the behaviour of partially miscible liquid systems with respect to change of temperature.

## Unit 6: Some Colligative Properties

### Table of Contents

	page
1.0 Introduction	150
2.0 Objectives	150
3.1 Relative Lowering of Vapour Pressure	150
3.1.1 Determination of Relative Molecular Mass from the Lowering of Vapour Pressure	151
3.1.2 Measurement of Vapour Pressure Lowering	151
3.2 Elevation of Boiling Point	154
4.0 Conclusion	156
5.0 Summary	156
6.0 References and Other Resources	156
7.0 Tutor-Marked Assignment	156

## 1.0 Introduction

In this Unit, we shall study colligative properties of the solutions containing non-volatile solutes. The colligative properties depend only upon the number of particles of the solute in the solution. They do not depend upon the nature of the solute. These properties help us in determining the relative molecular mass of a non-volatile solute. The colligative properties are:

- Relative lowering of vapour pressure,
- Elevation of boiling point,
- Depression of freezing point, and
- Osmotic pressure.

We shall study only the first two properties in this Unit.

## 2.0 Objectives

By the end of this Unit, you should be able to:

- Explain what is meant by colligative properties.
- State Raoult's law of relative lowering of vapour pressure.
- Explain elevation of boiling point

## 3.1 Relative Lowering of Vapour Pressure

You should recall we discussed pure and impure substances even when they are homogenous or heterogenous systems. If a pure liquid is placed in a closed container that is initially evacuated, the liquid evaporates to fill up the space above the liquid. At any given temperature when equilibrium is established, the pressure exerted by the vapours of a liquid is called the vapour pressure of the pure liquid ( $P^0$ ). If a non-volatile solute is added to this liquid, the equilibrium vapour pressure ( $p_1$ ) over the solution is found to be less than that of the pure liquid. According to Raoult's law, the vapour pressure ( $p_1$ ) of the solvent of an ideal solution is given by

$$P_1 = P^0 \cdot x_1 \quad \text{.....3.1}$$

Where  $x_1$  is the mole fraction of the solvent in the solution and  $P^0$  is the vapour pressure of the pure solute. Since the solute is non-volatile, its contribution towards the vapour pressure of the solution is negligible. Hence, the vapour pressure of solution containing a non-volatile solute is only due to the solvent. Since the mole fraction ( $x_1$ ) of the solvent is less than one, it is clear from Eq. 3.1 that  $p_1$  will also be less than  $P^0$ . The lowering of vapour pressure when a non-volatile solute is added to a solvent is given by ( $P^0 - p_1$ ).

Substitution for from Eq. 3.1, we get

$$P^0 - P_1 = P^0 - P^0 \cdot x_1 = P^0 (1 - x_1) \quad \text{.....3.2}$$

Since  $x_1 + x_2 = 1$ ,

$$P^0 - P_1 = P^0 \cdot x_2 \quad \text{.....3.3}$$

Where  $x_2$  is the mole fraction of the solute.

According to Eq.3.3, the lowering of vapour pressure of the solvent depends both on the vapour pressure of the pure solvent and on the mole fraction of the solute in the solution. In other words, it

depends on the nature of the solvent and on the concentration of the solute and not on the nature of the solute. Eq.3.3 can be written as

$$\frac{P_0 - P}{P_0} = x_2 \quad \dots\dots\dots 3.4$$

The expression on the left hand side of Eq.3.4 is called the relative lowering of vapour pressure. Eq.3.4 also may be stated as:

"The relative lowering of vapour pressure of a solution is equal to the mole fraction of the solute".  
The above statement is also called Raoult's law of relative lowering of vapour pressure.

### 3.f.1 Determination of Relative Molecular Mass from the Lowering of Vapour Pressure

Having discussed relative lowering of vapour pressure, it is possible to measure the relative molecular mass of a non-volatile solute, if we know the vapour pressure of a dilute solution containing the non-volatile solute. Now let us consider the equation that we need to measure the relative molecular mass from the lowering of vapour pressure.

Assuming  $w_2$  kg of the solute having molar mass  $M_2$  kg mol<sup>-1</sup> is dissolved in  $w_1$  kg of the solvent having molar mass  $M_1$  kg mol<sup>-1</sup>, then from Eq.3.4 we have:

$$\frac{P_0 - P}{P_0} = \frac{n_2}{n_1 + n_2} \quad \dots\dots\dots 3.5$$

$$\frac{P_0 - P}{P_0} = \frac{w_2/M_2}{w_1/M_1 + w_2/M_2} \quad \dots\dots\dots 3.6$$

For a dilute solution, the number of moles of the solute ( $n_2$ ) is negligible in comparison to the number of moles of solvent ( $n_1$ ). Thus Eq.3.6 reduces to

$$\frac{P_0 - P}{P_0} = \frac{w_2/M_2}{w_1/M_1} \quad \dots\dots\dots 3.7$$

Thus; if we are able to know the mass of the solvent, its relative molecular mass, mass of the solute, the vapour pressure of the solution and of the solvent, the relative molecular mass of the solute can be calculated from Eq.3.7.

### 3.1.2 Measurement of Vapour Pressure Lowering

The lowering of vapour pressure of a solvent when a non-volatile solute is dissolved in it can be measured by the following methods:

#### (i) Static Method

In this method, the difference between the vapour pressure of the solvent and the solution is determined with the help of a differential manometer. The apparatus is as shown in Fig.6.1. It consists of two bulbs which are connected to a manometer. One arm of the manometer is connected with the bulb, A, containing the solvent and the other arm with the bulb, B, containing the solution. The manometric liquid is an inert, non-volatile, low density liquid such as *o*-bromonaphthalene.

From the difference in the levels of the liquid in the two arms, the difference in vapour pressure between the solvent and the solution can be read directly.

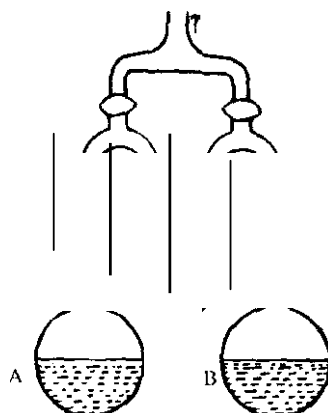
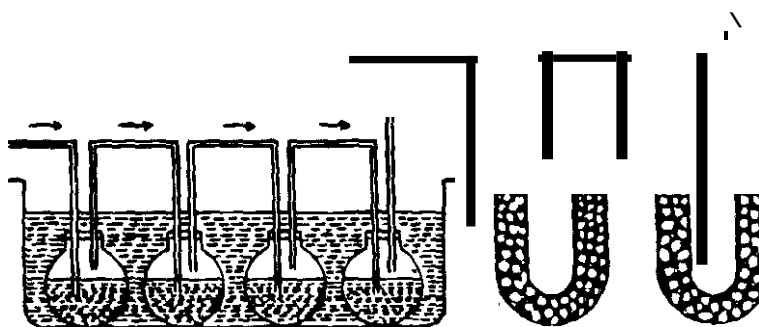

**Fig. 6.1:** Static Method for determining the lowering of vapour pressure

**(ii) Dynamic Method**

This method is due to Ostwald and Walker. In this method (Fig.6.2), a stream of dry and purified air is first passed through a pre-weighed set of bulbs containing the solution. The air coming out of the bulbs takes up an amount of vapour which is proportional to the vapour pressure of the solution. Evidently, the loss in mass suffered by the solution bulbs is proportional to the vapour pressure of the solution. If  $w_1$  is the loss in mass suffered by the solution bulbs and  $p$  is the vapour pressure of the solution, then we have.

$$w_1 \propto p, \quad \text{3.8}$$



**Fig. 6.2:** Ostwald and Walker apparatus for measuring the vapour pressure lowering. I: air; II: solution bulbs; III; solvent bulbs; IV: weighed  $\text{CaCl}_2$  tubes; V; dry  $\text{CaCl}_2$ .

The air coming out of the solution bulbs is then passed through pre-weighed set of bulbs containing the solvent. As the air containing vapours of the solvent passes through the solvent, it takes up a further amount of vapour which is proportional to the difference in vapour pressures of the solvent and the solution. Evidently the loss in mass suffered by the solvent bulbs is proportional to the difference in vapour pressures of the pure solvent and the solution. If  $w_2$  is the loss in mass suffered by the solvent bulbs and  $p'$  is the vapour pressure of the solvent, then we have

$$w_2 \propto p' - p, \quad \text{3.9}$$

From Eqs.3.8 and 3.9 we have

$$(w_A + w_B) a p_1 + p_1^0 = P, \quad \text{or } (w_A + w_B) a p_1^0 = P - p_1^0 \quad 3.10$$

From Eqs.3.8 and 3.10 we have.

$$\frac{p_1^0 - p_1}{p_1^0} = \frac{w_B}{w_A + w_B} \quad 3.11$$

Thus knowing  $w_A$  and  $w_B$ , the relative lowering of vapour pressure can be calculated using Eq.3.11.

If the solvent is water, the moist air coming out of the solvent bulbs may be passed through a weighed tube containing fused calcium chloride which absorbs moisture from moist air. The mass of calcium chloride tube will increase and the increase in mass will be equal to  $(w_A + w_B)$ .

### Example I

The vapour pressure of a solution containing 0.012 kg of a solute dissolved in 0.100 kg of water at 300 K is  $3.50 \times 10^3$  Pa. Calculate the molar mass of the solute, if the vapour pressure of water at 300 K is  $3.70 \times 10^3$  Pa.

### Solution

$w_A, 0.100 \text{ kg}$	$w_B, 0.012 \text{ kg}$
$M, 0.018 \text{ kg mol}^{-1}$	$M,$
$p_1^0, 3.70 \times 10^3 \text{ Pa}$	$P, 3.50 \times 10^3 \text{ Pa}$

Using Eq.3.7, we have

$$\frac{(3.70 \times 10^3 \text{ Pa} - 3.50 \times 10^3 \text{ Pa})}{3.70 \times 10^3 \text{ Pa}} = \frac{(0.012 \text{ kg})(M)}{0.100 \text{ kg}(M)}$$

$$\text{or } M = \frac{(0.012 \text{ kg})(0.018 \text{ kg mol}^{-1}) \times 3.70 \times 10^3 \text{ Pa}}{0.100 \text{ kg} \times (0.20 \times 10^3 \text{ Pa})}$$

$$0.040 \text{ kg mol}^{-1}$$

In this section, we discussed the correlation between the relative lowering of vapour pressure and the mole fraction of a non-volatile solute in a solution. In the next section, we shall study how the boiling point of a solvent is suffered when a non-volatile solute is added to it.

### Exercise I

State whether the following statements are true or false:

- (i) Lowering of vapour pressure is not a colligative property.
- (ii) Relative lowering of vapour pressure is equal to the mole fraction of the solvent.
- (iii) Relative lowering of vapour pressure depends upon the number of particles of the solute and the solvent.

### 3.2 Elevation of Boiling Point

The temperature, at which the vapour pressure of the liquid becomes equal to the atmospheric pressure, is called the boiling point of the liquid. Since, according to Raoult's law, the vapour pressure of a solution containing a non-volatile solute is less than that of its pure solvent, the boiling point of such solution will be higher than the boiling point of the pure solvent. This is because when a non-volatile solute is added to a solvent at a particular temperature, the vapour pressure of the solvent decreases. Thus, the solution has to be heated further to make its vapour pressure equal to the atmospheric pressure. This can be understood from the vapour pressure curves plotted in Fig.6.3.

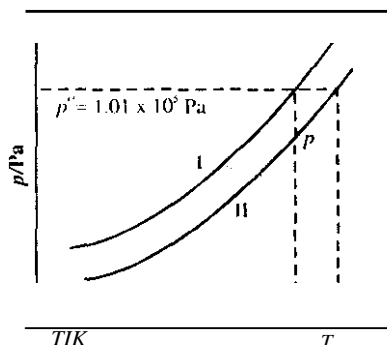

Fig. 6.3: Elevation of boiling point

The curve I represents the variation of vapour pressure of the pure solvent with temperature. The curve II represents the variation of vapour pressure of a dilute solution of known concentration with temperature. The boiling point of the solvent is  $T$ , and that of the solution is  $T''$  so that the elevation in boiling point is  $T'' - T = \Delta T_b$ . At temperature  $T''$  the lowering of vapour pressure of a solvent, when a non-volatile solute is added to it, is  $p'' - p$ . From the vapour pressure curve of the solution, it is clear that the vapour pressure of the solution is  $p$  at  $T$ , and  $p''$  at  $T''$ .

#### Determination of Boiling Point Elevation

For measuring the elevation of boiling point, a number of methods are available. In all these methods, care is taken to avoid superheating of the liquid. The most commonly used methods are given overleaf:

##### (i) The Landsberger Method

In this method, the solvent or the solution is heated to its boiling point by passing the vapours of the solvent through them. As the vapour condenses, they give up their latent heat to heat the solvent or the solution. Superheating is nearly impossible in this way because, when the boiling point is reached, the vapour will be in equilibrium with the liquid at atmospheric pressure and no more vapour will condense. The apparatus is shown in Fig.6.4a. It consists of flask A which contains the solvent.

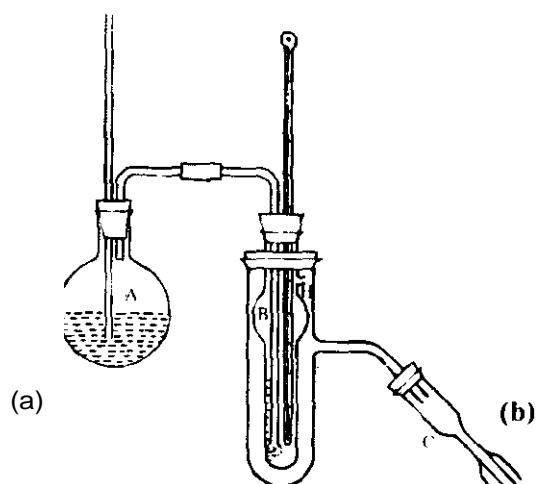

Fig. 6.4: (a) Apparatus for Landsberger method: (b) Beckmann thermometer

The flask is connected to a graduated tube B which also contains the solvent. Solvent in flask A is boiled so that the vapour pass into the solvent in B. where these vapour emerge in small bubbles through a number of holes at the end of the tube. The temperature of the solvent rise and willn it becomes constant. it is noted. Any excess vapour pass from the right hand top portion (H) of the graduated tube (B) into the condenser (C). A known mass of the non-volatile solute is then added to the solvent in B. The solution is then again heated by passing the vapour of the solvent through it. When the temperature reaches a constant value. it is cooled. The passage of vapours is stopped and the volume of the solution is noted as shown on the graduated tube. A thermometer, which is graduated in tenths of a degree and is capable of reading up to 0.0 I", is generally used. One such thermometer is the Beckmann thermometer (Fig. 6.4b). Knowing the density of the solvent. the mass of the solvent in the solution can be calculated. The volume of the solute is supposed to be negligible. The difference between the two boiling points gives the elevation in boiling point.

(2) Cottrell's Method

The apparatus is as shown in Fig.6.5. It consists of a graduated tube A which contains the liquid-solvent or the solution. An inverted funnel is placed in the tube A through which the bubbles rise. When the liquid starts boiling, a steam of liquid and vapour is poured over the bulb of a Beckmann thermometer so that the bulb of the thermometer is covered with a thin layer of the boiling liquid. After detennining the boiling point of the pure solvent, a known mass of the solute is added and the boiling point of the solution is again detemlined.

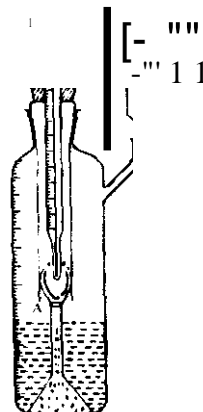

Fig. 6.5: Appurulus jiJr (o/IJ·e/1.; me/hod



The difference between the two readings gives the elevation in boiling point. You will learn more about boiling point elevation later in your programme.

#### Exercise 2

Explain why the boiling point of a solution is higher than that of a pure solvent.

## 4.0 Conclusion

In this Unit, we were able to examine some colligative properties specifically the lowering of vapour pressure and elevation of boiling point. The methods for determining boiling point elevation and lowering of vapour pressure were described. Later in another physical chemistry course, we shall consider other colligative properties and their related measurements.

## 5.0 Summary

At the end of this Unit, you have learnt that:

- Colligative properties of a solution depend upon the number of particles of a solute present in the solution.
- Colligative properties are independent of the nature of the solute.
- The colligative properties we discussed in this Unit are relative lowering of vapour pressure and elevation of boiling point.
- According to Raoult's law, relative lowering of vapour pressure is equal to the mole fraction of the solute.
- Since the addition of a non-volatile solute to a solvent decreases the vapour pressure of the solvent, the boiling point of the solution containing a non-volatile solute is higher than that of the pure solvent.

## 6.0 References and Other Resources

IGNOU (1993). Solutions and Phase Equilibrium: Physical Chemistry 3 CHE-04, pp 26-32.

## 7.0 Tutor-Marked Assignment

1. Define colligative property. Name two of them.
2. What is Raoult's law of relative lowering of vapour pressure?

## Unit 7: Phase Rule

### Table of Contents

	Page
1.0 Introduction	158
2.0 Objectives	158
3.1 Definition of the Terms	158
3.1.1 Phase	158
3.1.2 Definition of Number of Components	159
3.1.3 Degree of Freedom	160
3.2 Phase Rule	160
3.3 Phase Diagrams	162
3.4 Stability of the Phases of a Pure Substance	163
4.0 Conclusion	164
5.0 Summary	164
6.0 References and Other Resources	164
7.0 Tutor-Marked Assignment	164

## 1.0 Introduction

The study of the effect of various parameters such as pressure, temperature or composition on the physical state of chemical substances is the subject matter of phase equilibria. In the last Unit, you have studied the criteria for equilibrium. In this Unit, we shall consider the various aspects of chemical equilibria. This means:

- focusing our attention on the equilibria regarding physical state and
- relating physical equilibria to various parameters such as pressure, temperature and composition using phase rule.

We shall define the terms such as phase, component, degrees of freedom and phase transition. We will deduce phase rule. One-component system will be studied in the light of phase rule. Gas systems will be discussed.

## 2.0 Objectives

By the end of this Unit, you should be able to:

- Define the terms phase, component and degree of freedom
- Calculate the number of phases, components and degrees of freedom in a system
- State and deduce the phase rule
- Comment on the stability of the phases of subliming and non-subliming substances.

## 3.1 Definition of the Terms

In 1876, Gibbs deduced a simple relationship among the number of phases in equilibrium, the number of components and the number of intensive variables known as degrees of freedom. Let us define the terms phase, component and degrees of freedom.

### 3.1.1 Phase

In Units 8 and 9, we examined phases of different liquid-liquid solutions. Try to recollect and define a phase as given in these Units. We can define a phase as a physically distinct and homogeneous part of the system that is mechanically separable from other parts of the system. The definition as suggested by Gibbs is that a phase is a state of matter that is uniform throughout, not only in chemical composition but also in physical state.

#### Example I

- A gas or a gaseous mixture is a single phase since there cannot be an interface between one gas and another. Air, for example, is one phase system, although it is a mixture of many gases.

#### Example II

- A system of totally miscible liquids will exist in one phase only as far as the liquid phase is concerned. But since each liquid has its vapour above, the total number of phases in a system of miscible liquids is two, one for the liquid and the other for vapour. These two phases are separated by the surface of the solution in the liquid phase.

#### Example III

- A system of two immiscible liquids has a total of three phases, two for the substances in the liquid state and another for the vapour phase containing vapours of both the liquids.

### Example IV

- e A crystal is a single phase. Different solids having different crystal structures constitute different phases, irrespective of the fact whether they have same chemical composition or not. A mixture of graphite and diamond constitutes two phases although both are only allotropic modifications of carbon.

Next, we take up the definition of the word, component.

### 3.1.2 Definition of Number of Components

The number of components (*c*) in a system is the smallest number of substances in terms of which the composition of all the phases in the system can be described separately. The number of component may be smaller than the number of chemical substances that are present in the system.

The definition is easy to apply when the species do not react, for them we simply count their number. For example, phase equilibria containing ice, water and its vapour is a one-component system since the composition of each phase can be expressed in terms of the component, H<sub>2</sub>O, only. A mixture of ethanol and water is a two-component system.

If the species react chemically and are at equilibrium, we have to take into account the significance of the phrase 'all the phases' in the above definition. Dissociation of calcium carbonate in a closed vessel is a two-component system, although at first, it may appear to be a three-component system, namely, CaCO<sub>3</sub>, CaO and CO<sub>2</sub>.



You can see that the composition of any one species is related to the other two and the dissociation of calcium carbonate is, therefore, a two-component system.

In the case of solid ammonium chloride being heated in a closed vessel, there is an equilibrium between the solid ammonium chloride and its vapour (which consists of ammonia and hydrogen chloride molecules). Since both the phases have the formal composition 'NH<sub>4</sub>Cl', it is a one-component system. However, if ammonia or hydrogen chloride is added to the system, the system has two components because now the relative amounts of hydrogen chloride and ammonia are not the same.

If there are '*S*' substances (may be chemical compounds or ionic species) and '*R*' relations (which include equations representing chemical equilibria or charge neutrality) among them, then the number of components (*C*) can be calculated using the equation,

$$C = S - R \quad \dots\dots\dots 3.1$$

To illustrate this, we can consider two examples. If you consider a solution of glucose in water, there are two substances and hence *S* = 2. But there is no relation between them and so *R* = 0; therefore, *C* = 2 and this is a two component system.

Let us re-examine the equilibrium of solid ammonium chloride with its vapour. Here *S* = 3 since there are three substances, NH<sub>4</sub>Cl, NH<sub>3</sub>, and HCl. But *R* = 2 since these are two relations as shown below:

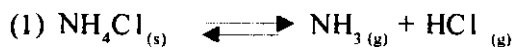

(2) Concentration of  $\text{NH}_3 = \text{Concentration of HC}$  (and both of them are in gaseous phase).

Therefore  $C = S - R = 3 - 2 = 1$ . This is a one-component system. If extra  $\text{HC}$  (g) is added then, the second relation given above will no more hold. That is,  $R = 1$  although  $S = 3$ . This is therefore a two component system, as  $C = S - R = 3 - 1 = 2$ .

### 3.1.3 Degrees of Freedom

The number of degrees of freedom (F) or variance of a system is the smallest number of intensive variables, such as pressure, temperature and composition, which are to be specified to describe the state of the system completely.

- If  $F = 0$ , the system is invariant and this means none of the intensive variables can be changed.
- In case  $F = 1$ , the system is univariant and one of the intensive variables can be changed.
- For a bivariant system, F is equal to 2, and two of the intensive variables can be changed.

The phase rule relates the degrees of freedom to the number of phases and the components. Before studying phase rule, let us recapitulate the criteria for equilibrium.

#### Exercise 1

Calculate the number of phase in the following cases:

- A closed beaker partially filled with toluene and water.
- A closed beaker partially filled with acetone and water.

#### Exercise 2

Calculate the number of components in the following cases:

- Dissociation of ammonia in a closed vessel;
- Dissociation of ammonia in a closed vessel containing nitrogen.

## 3.2 Phase Rule

In a heterogeneous equilibrium, not influenced by gravitational or electrical or magnetic forces, the number of degrees of freedom (F) of the system is defined by the number of components (C) and the number of phases (P) according to the equation,

$$F = C - P + 2 \quad \dots\dots\dots 3.2$$

Once the values of C and P are known, F can be calculated.

Let us take up some examples to understand Eq. 3.2. In the vaporization equilibrium of water ( $C = 1$ ), there are two phase (liquid and vapour) and hence,  $F = C - P + 2 = 1 - 2 + 2 = 1$ . That is, specifying

pressure or temperature fixes the other. This is all the more understandable from the general statement that at a particular temperature, vapour pressure of a liquid is constant. If all the three phases, ice, water and its vapour, are to be in equilibrium, then  $F = 3 - 2 = 1$ ; that is, the system is invariant. This means all the three phases of water are in equilibrium only at a fixed temperature and pressure. Any effort to change pressure or temperature results in the disappearance of one of the phases.

### Deduction of Phase Rule

Having stated the phase rule, we shall now deduce the same. Consider a system of  $C$  components existing in  $P$  phases. We want to calculate the number of independent variables or degrees of freedom ' $F$ ' in order to define the state of the system completely. The value of  $F$  can be given by the following equation also:

$$F = (\text{Total number of variables}) - (\text{number of relations}) \quad \dots\dots\dots 3.3$$

First, let us calculate the total number of variables. To define the composition of each phase, it is necessary to define the concentration of  $(C - 1)$  constituents of that phase. For  $P$  phases, the total number of concentration variable is  $P(C - 1)$  and these, along with two variables, pressure and temperature, constitute the total number of variables.

$$\text{Total number of variables} = P(C - 1) + 2 \quad \dots\dots\dots 3.4$$

Regarding the number of relations, we know that for one component existing in three phases  $\alpha$ ,  $\beta$  and  $\gamma$ , there are two relations,

$$\mu_\alpha = \mu_\beta \quad \text{and} \quad \mu_\beta = \mu_\gamma$$

The relation  $\mu_\alpha = \mu_\gamma$  need not be specified but is understood. As two relations are required for three phases of a component,  $(P - 1)$  relations are there for  $P$  phases of a component. Hence, a total number of  $C(P - 1)$  relations exist for  $P$  phases of  $C$  components.

$$\text{Number of relations} = C(P - 1) \quad \dots\dots\dots 3.5$$

Using Eqs. 3.4 and 3.5 in Eq. 3.3,

$$F = P(C - 1) + 2 - C(P - 1)$$

$$F = PC - P + 2 - PC + C$$

$$\text{i.e., } F = C - P + 2 \quad \dots\dots\dots 3.6$$

Having derived phase rule, we will apply it to various systems. Its application can be seen in the study of phase diagrams, A phase diagram speaks about the stability of various phases at various temperatures, pressures and compositions.

### Exercise 3

The four phases of sulphur are rhombic, monoclinic, liquid and vapour. Can all these four phases exist in equilibrium at a particular temperature and pressure?

### 3.3 Phase Diagrams

So far, we have shown that a substance primarily exists in various physical states depending on the specific conditions which prevail. The phase rule is used in summarizing the behaviour of the substance in that system. In this section, the phase diagrams of various examples of one component system will be provided. You will need to interpret these diagrams following a rule termed *phase rule*. Then, what did we say a phase rule is? Let us examine some phase diagrams of one component system.

#### Example 1

##### Phase Diagram of Water

In Fig. 7.1, the phase diagram of water. you can observe (i) curve OC represents the equilibrium between liquid water (l) and water vapour (g); (ii) along line O8, fusion and vaporization (ice-water-water vapour) are in equilibrium.

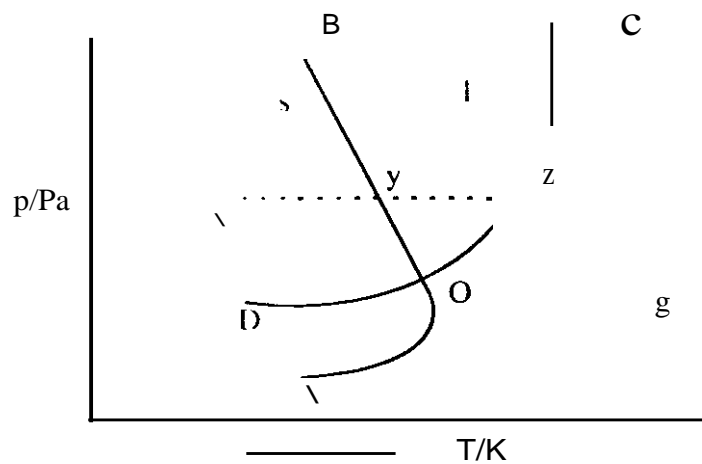

Fig. 7.1: Phase diagram of water; s, l and g .\}andfor solid, liquid and vapour phases respectively

Now for curve OA, what does it represent? Curve OA from the diagram represents the sublimation equilibrium of water solid (ice -> vapour). Point O is termed Triple point. At this Triple point, three phases are in equilibrium (solid, liquid and vapour, meaning  $P=3$ ). The freezing point is point Y. Now look at the diagram and state the point of normal boiling point of water. Your answer should be around curve OC. The point Z is the answer.

#### Example 2

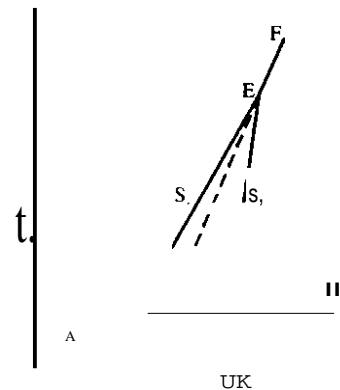

Fig. 7.2: Phase diagram of Sulphur; S, S<sub>2</sub>, S<sub>3</sub>, and S<sub>4</sub>, refer to rhombic, monoclinic, liquid and vapour phases of sulphur.

In Fig. 7.2, the stable form of sulphur at ordinary temperatures and under one atmosphere pressure is rhombic sulphur. If rhombic sulphur is heated, it slowly transforms to solid monoclinic sulphur at 368.6 K. Above 368.6 K, monoclinic sulphur is stable and melts at 392.2 K to give liquid sulphur which is stable up to its boiling point (717.8 K). The transformation of one crystal line modification to another is often very slow if rhombic sulphur is heated quickly to 387.2 K, it melts. The curve **BO** represents the metastable equilibrium, between rhombic sulphur and sulphur vapour. Likewise, if liquid sulphur is allowed to cool quickly, monoclinic sulphur may not appear.

### 3.4 Stability of the Phases of a Pure Substance

The golden rule with reference to phase study is that phase with the lowest chemical potential,  $\mu$ , is the stable phase. This rule can be used in making inferences from the curves obtained by plotting chemical potential of a pure substance against temperature for each phase. For most of the substances,  $\mu$  against  $T$  plots for solid, liquid and vapour phases are of the type shown in Fig. 7.3a.

At the melting point ( $T_m$ ), the solid curve (AB) and the liquid curve (CD) meet. Similarly, at the boiling point ( $T_b$ ), the liquid curve (CD) and the vapour curve (EF) meet.

Applying the golden rule given at the beginning of this section, we can infer that for substances exhibiting behaviour of the type represented in Fig. 7.3a, solid phase is stable phase below the melting point. Between melting and boiling points, liquid phase is stable and above boiling point, vapour phase is stable. Evidently this is applicable for non-subliming substances.

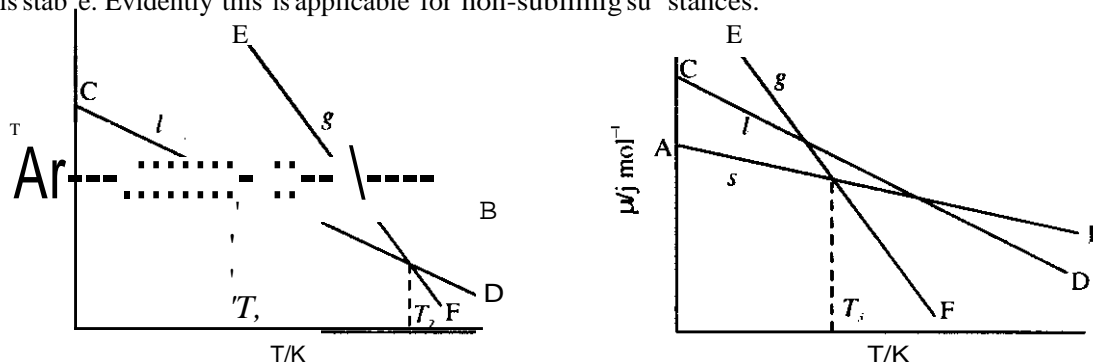

Fig. 7.3:  $\mu$  against  $T$  plots at constant pressure: (a) for non-subliming substance (b) for subliming substances; in both the plots,  $g$ ,  $l$  and  $s$  refer to vapour, liquid and solid phase curves

In the case of subliming substances,  $\mu$  against  $T$  curves are of the type shown in Fig. 7.3b. The sublimation temperature ( $T_s$ ), is the point of intersection between the solid (AB) and the vapour (EF) curves. Hence, below  $T_s$ , solid phase is stable and above  $T_s$ , the vapour phase is stable.

As per Clapeyron equation studied earlier, we are aware that a decrease in pressure affects melting and boiling points to a different extent. If the pressure is reduced sufficiently, the boiling point of a liquid may even fall below the melting point of a solid whereby the substance is said to be sublime. Hence, the type of  $\mu$  Vs  $T$  curves and the type of stable phase would be decided by the experimental conditions of pressure, solid carbon (IV) oxide melts to give a liquid and, below  $5.2 \times 10^5$  Pa pressure, solid carbon (IV) oxide sublimes.



#### Exercise 4

In Fig. 7.1, a graph gives  $\ln p$  against  $T$  plot of a pure substance at constant pressure. For a substance in a closed system,

d)  $\ln p = \frac{Vdp}{RdT}$ .

What thermodynamic property of a substance is given by the slope of Fig. 7.3 a graph?

### 4.0 Conclusion

In this Unit, we have explained the terms phase, component and degree of freedom. The phase rule has been applied to one component system. The Unit helps us to examine the influence of variables like pressure, temperature and composition on the phase equilibria of substances. Details of phase rule applications would be studied later on in the programme.

### 5.0 Summary

At the end of this Unit, you have learnt that:

- A phase is a physically distinct and homogenous part of the system.
- There may be one or more components in what is termed a system.
- The phase rules relate the number of variables to the number of phases and the components.
- We can predict the existence of a system in equilibrium at a particular temperature and pressure once we apply the phase rule.

### 6.0 References and Other Resources

IGNOU (1993). Solutions and Phase Equilibrium: Physical Chemistry, 3 CHE-04 pp 26-32.

### 7.0 Tutor-Marked Assignment

1. Examine the following statements and write 'true' for the correct ones and 'false' for the wrong ones:
  - (a) The number of phases of a mixture of three gases enclosed in a container is 3.
  - (b) The number of phases of a mixture of ethyl alcohol and water is 2.
  - (c) The equilibrium point among ice, water and vapour is called eutectic point.
  - (d) The number of phases present in a vessel half filled with water is 1.
  - (e) The melting point of ice decreases with increasing pressure.
2. Fill in the blanks:
  - (a) The equilibrium between liquid water and vapour below 273K is an example for a.....
  - (b) In a one-component system, maximum number of phase that can co-exist in a true equilibrium is .....
  - (c) Boiling point of water ..... with increase in pressure.
  - (d) A phase transition requiring latent heat is called ..... phase transition.
  - (f) A melt of eutectic composition when cooled shows only a ..... in the cooling curve.