



# Kindergarten Worksheet Bundle:

## Volume Two

Printable math, reading, and literacy worksheets from Edmentum Exact Path and Reading Eggs.





# Math Activities



# All Sorts of Animals

## Activity Sheet

Name: \_\_\_\_\_ Class: \_\_\_\_\_

Color the animals at the bottom of the page.

Cut on the dotted lines.

Sort and paste the animals into the categories **Stripes** and **No Stripes**.

**Stripes**

**No Stripes**

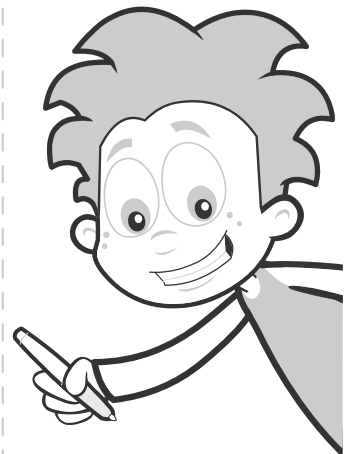
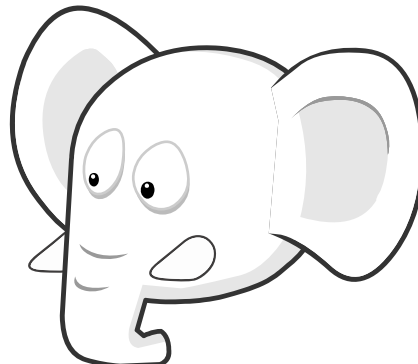
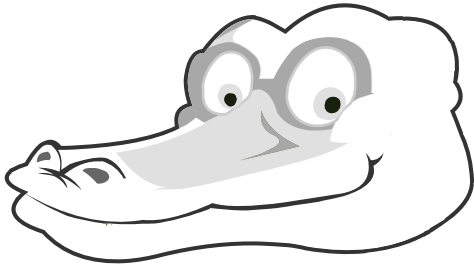



# All Sorts of Animals - Answer Key

## Activity Sheet

Name: \_\_\_\_\_ Class: \_\_\_\_\_

Color the animals at the bottom of the page.

Cut on the dotted lines.

Sort and paste the animals into the categories **Stripes** and **No Stripes**.

**Stripes**

**No Stripes**

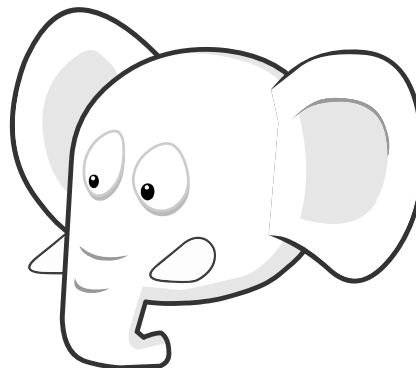
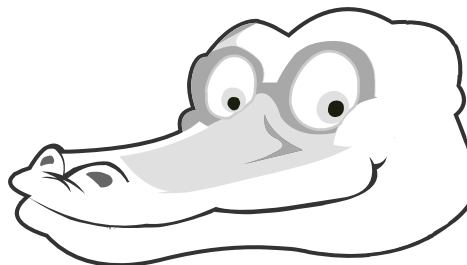



# Counting Cars

## Activity Sheet

Name: \_\_\_\_\_ Class: \_\_\_\_\_

Color the group with less bears.

1

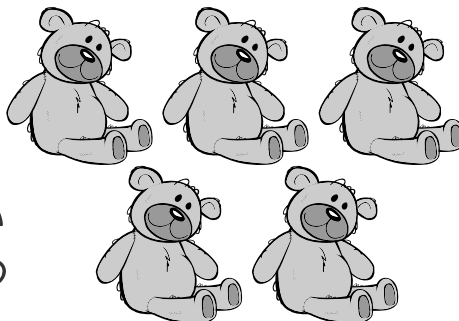

Color the group with more cars.

2

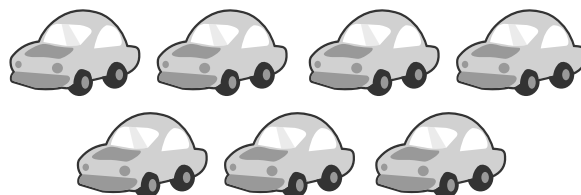
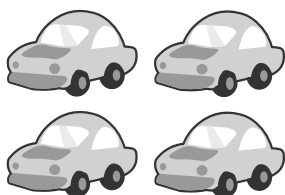

Which number is greater? Color the correct toy.

3

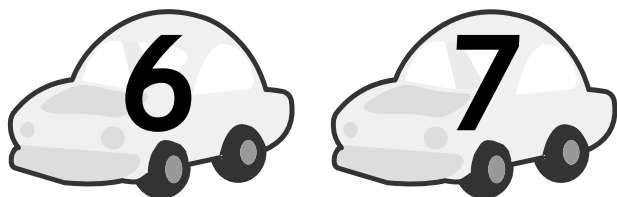

4

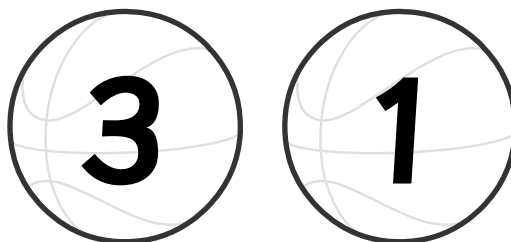

Which number is less? Color the correct toy.

5

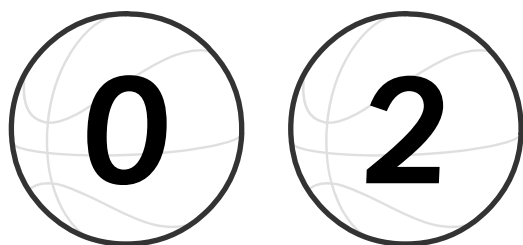

6

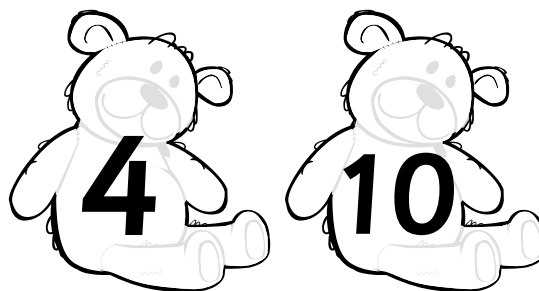

The teacher should read aloud the directions to the students.



# Counting Cars - Answer Key

## Activity Sheet

Name: \_\_\_\_\_ Class: \_\_\_\_\_

Color the group with less bears.

1

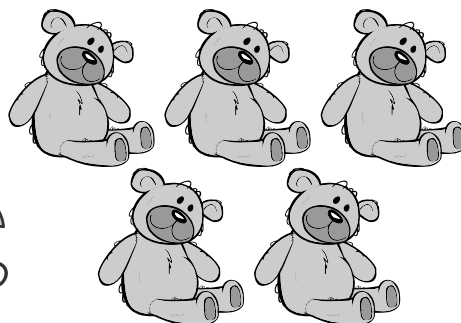

Color the group with more cars.

2

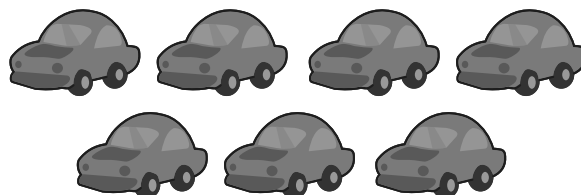
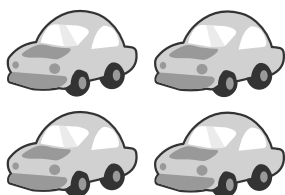

Which number is greater? Color the correct toy.

3

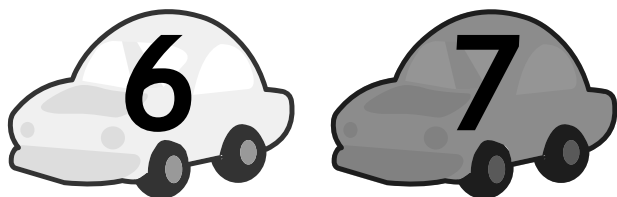

4

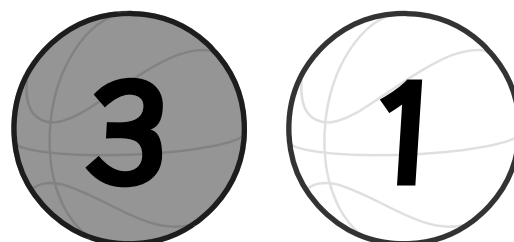

Which number is less? Color the correct toy.

5

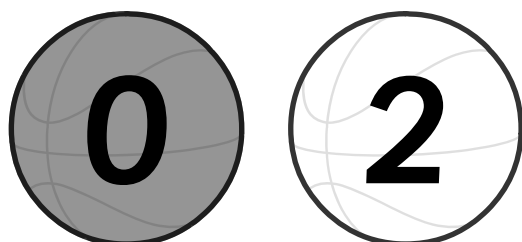

6

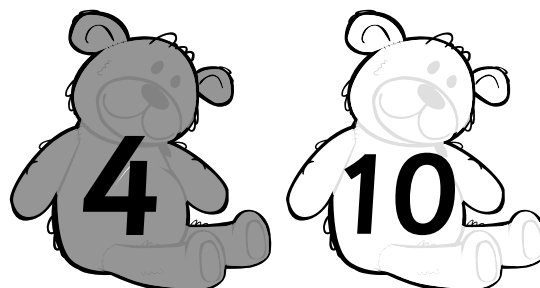

The teacher should read aloud the directions to the students.



# Fruit Frenzy

## Activity Sheet

Name: \_\_\_\_\_ Class: \_\_\_\_\_



Here is a picture of six plums.

Look at the groups below.

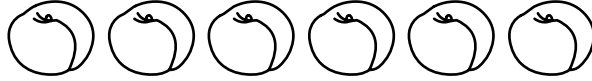

Circle the group that has **more than** six pieces of fruit.

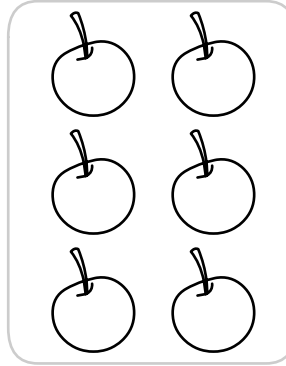
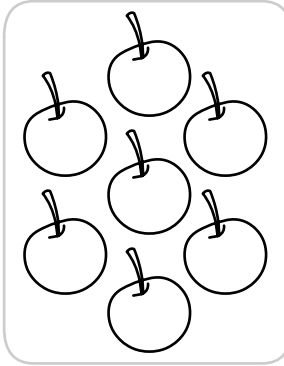
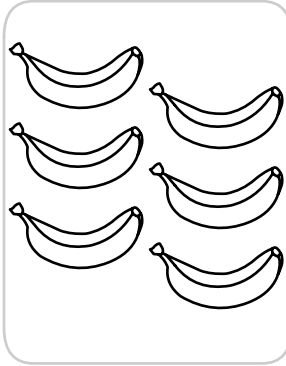
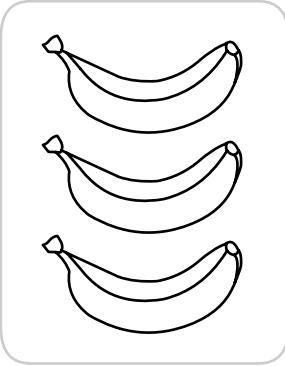

Here is a picture of three plums.

Look at the groups below.



Underline the group that has **fewer** than three pieces of fruit.

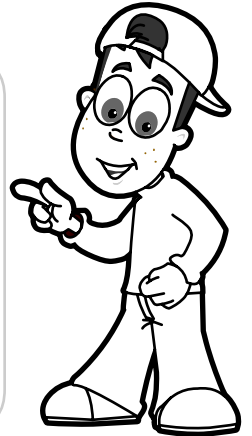
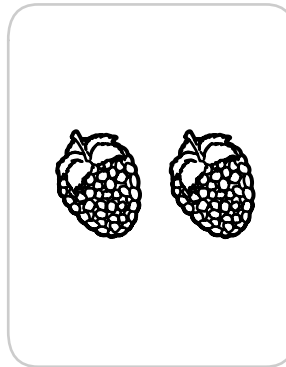
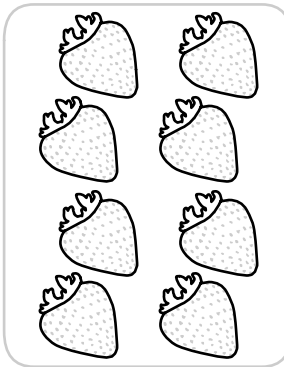
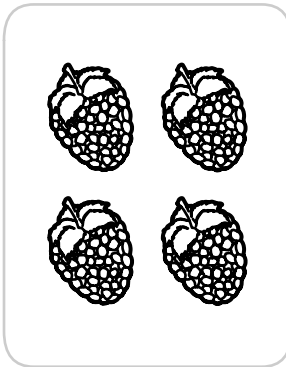
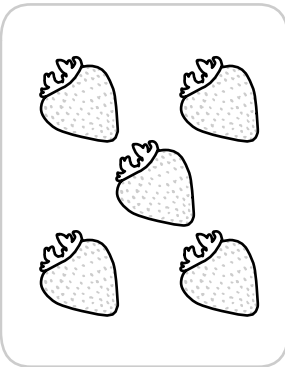

There are the same number of bananas as plums.



Color the two groups that have the **same** amount of fruit.

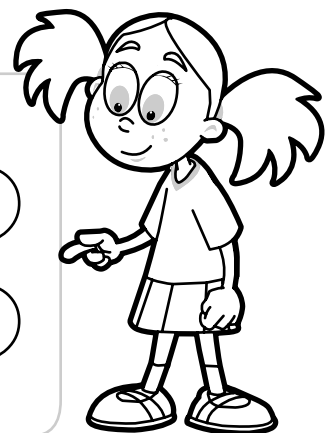
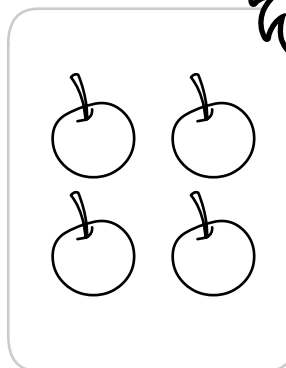
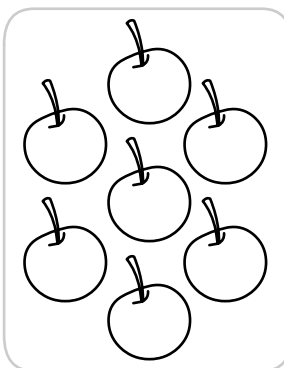
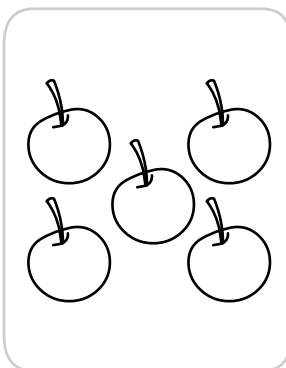
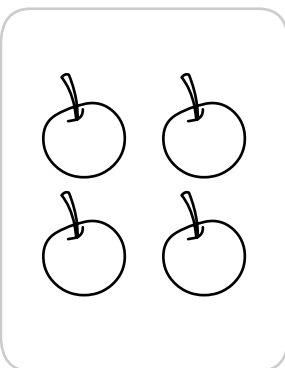



# Fruit Frenzy - Answer Key

## Activity Sheet

Name: \_\_\_\_\_ Class: \_\_\_\_\_

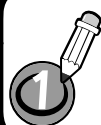

Here is a picture of six plums.

Look at the groups below.

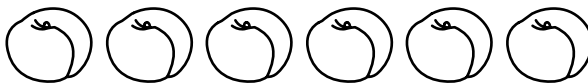

Circle the group that has **more than** six pieces of fruit.

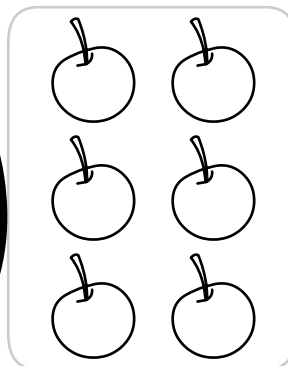
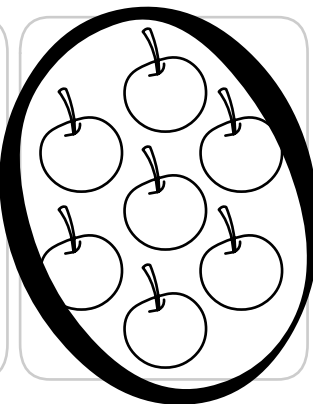
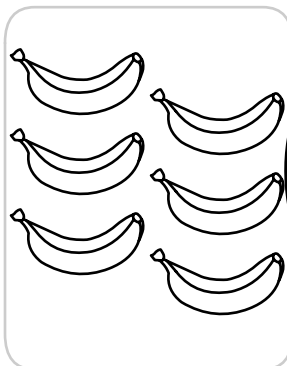
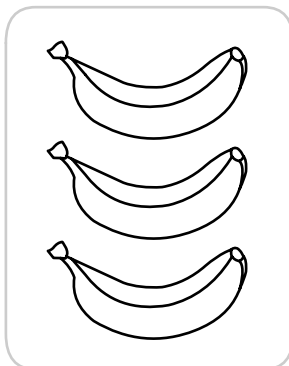

Here is a picture of three plums.

Look at the groups below.



Underline the group that has **fewer** than three pieces of fruit.

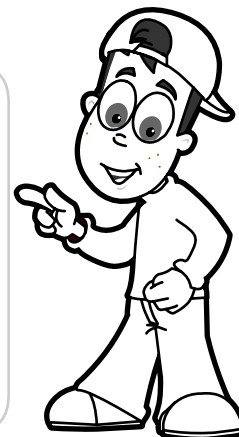
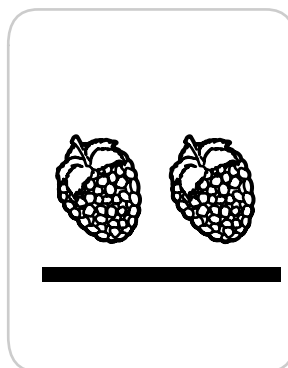
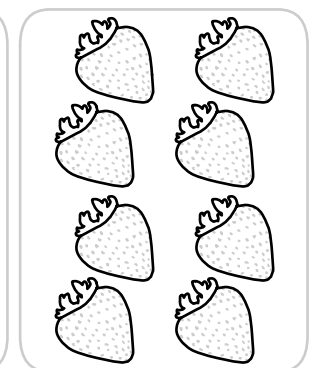
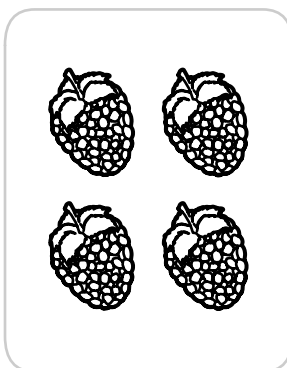
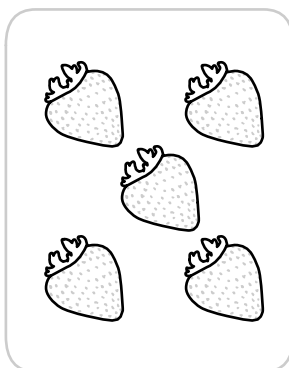

There are the same number of bananas as plums.



Color the two groups that have the **same** amount of fruit.

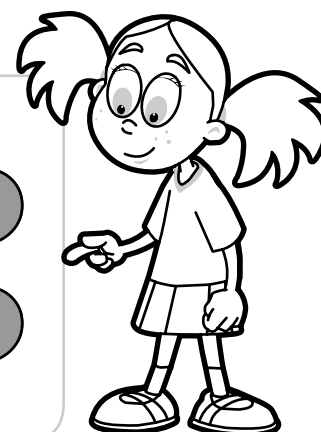
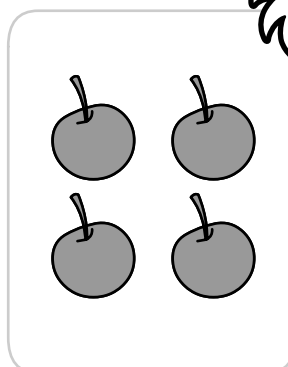
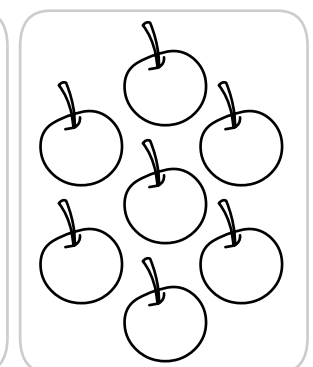
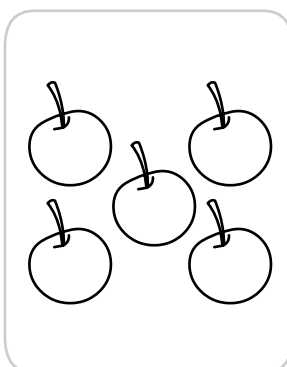
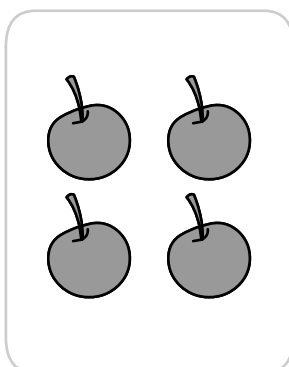





# Measure Up

Activity Sheet

Name: \_\_\_\_\_ Class: \_\_\_\_\_

Circle the item that is taller.

1

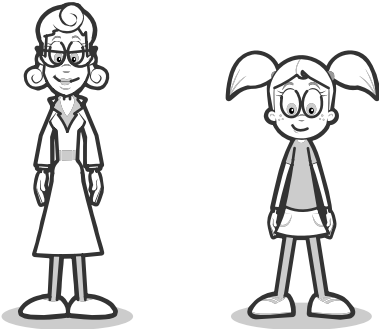

2

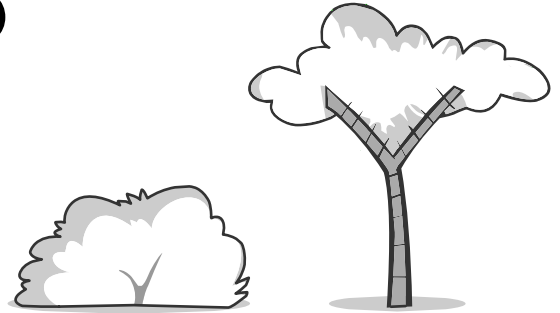

Circle the item that holds more.

3



4

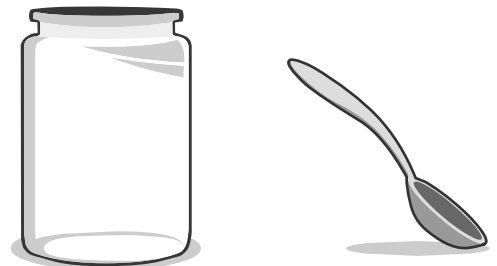

Circle the item that is shorter.

5

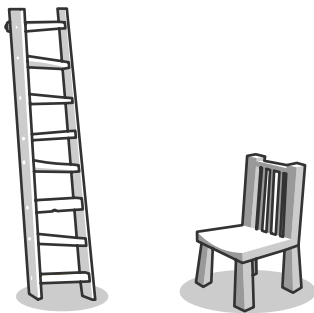

6

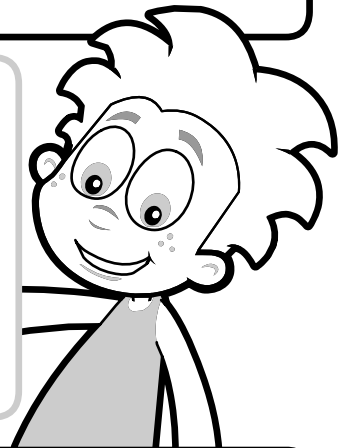
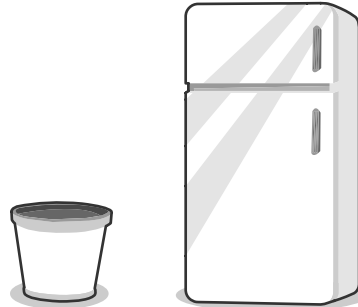

Circle the item that holds less.

7

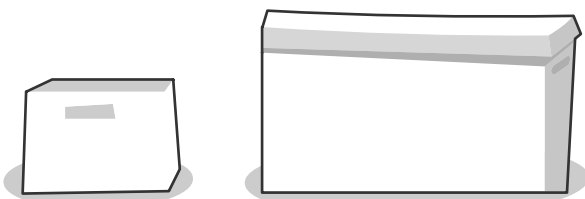

8

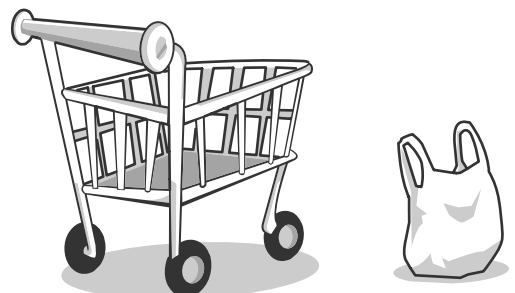



# Measure Up - Answer Key

## Activity Sheet

Name: \_\_\_\_\_ Class: \_\_\_\_\_

Circle the item that is taller.

1

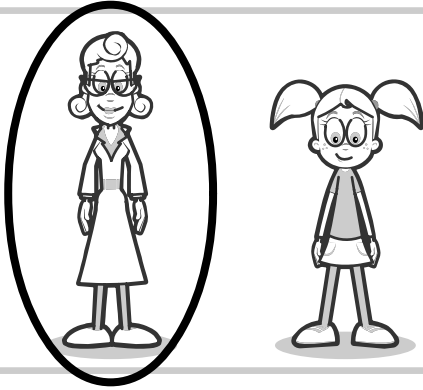

2

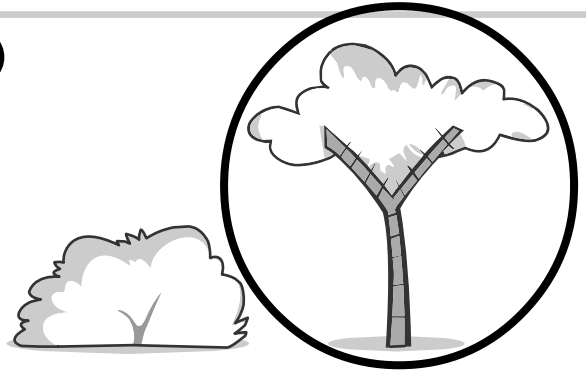

Circle the item that holds more.

3

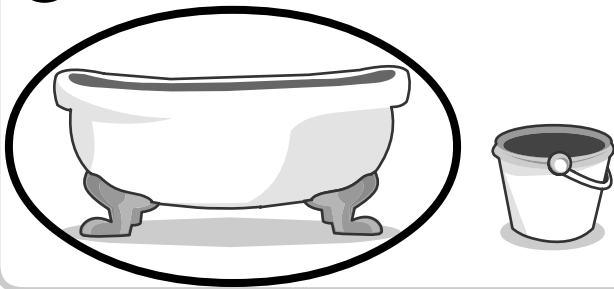

4

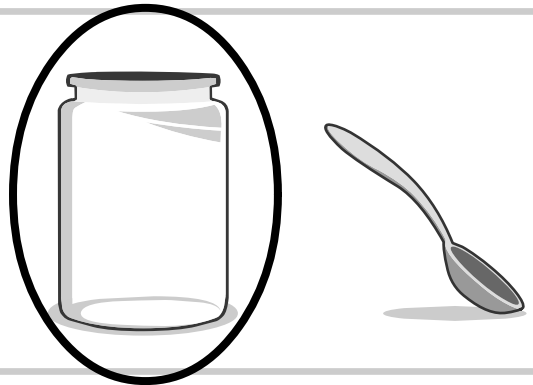

Circle the item that is shorter.

5

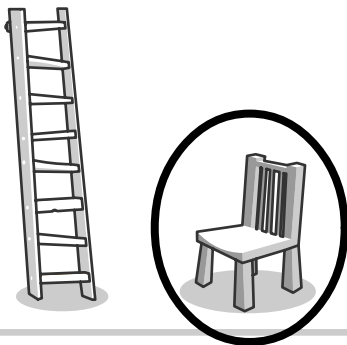

6



Circle the item that holds less.

7

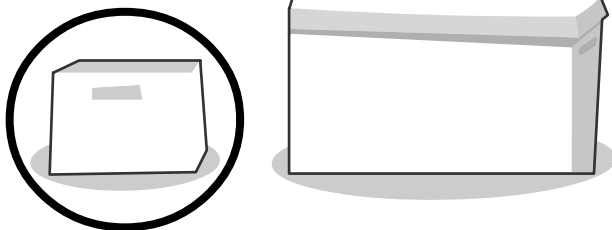

8





# Measure Up

## Activity Sheet

Name: \_\_\_\_\_ Class: \_\_\_\_\_

Color the tool you can use to measure length blue.

Color the tool you can use to measure volume in green.

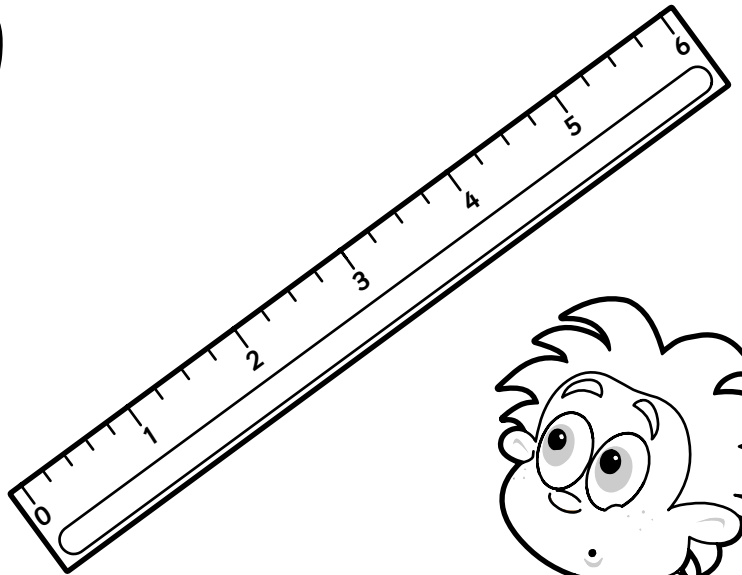
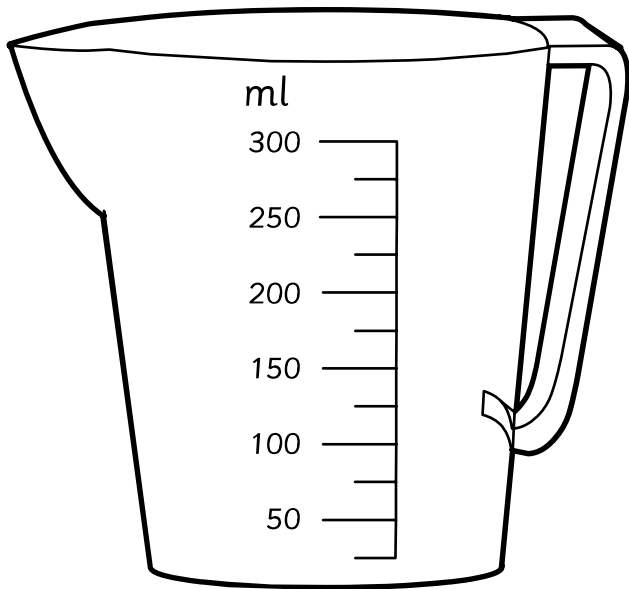

Circle the item that is longer.

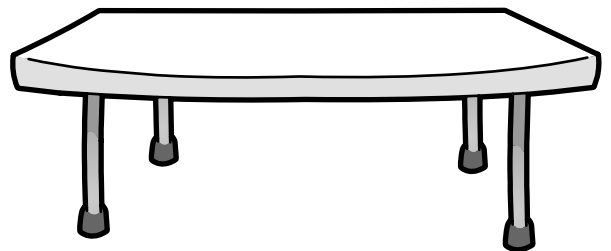
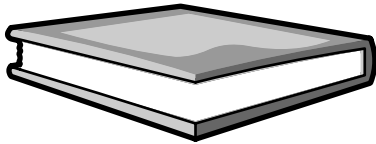

Circle the item that is heavier.



Circle the item that has more volume.

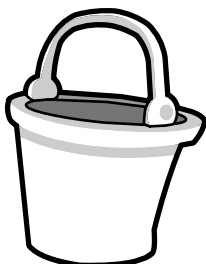



# Measure Up - Answer Key

## Activity Sheet

Name: \_\_\_\_\_ Class: \_\_\_\_\_

Color the tool you can use to measure length blue.

Color the tool you can use to measure volume in green.

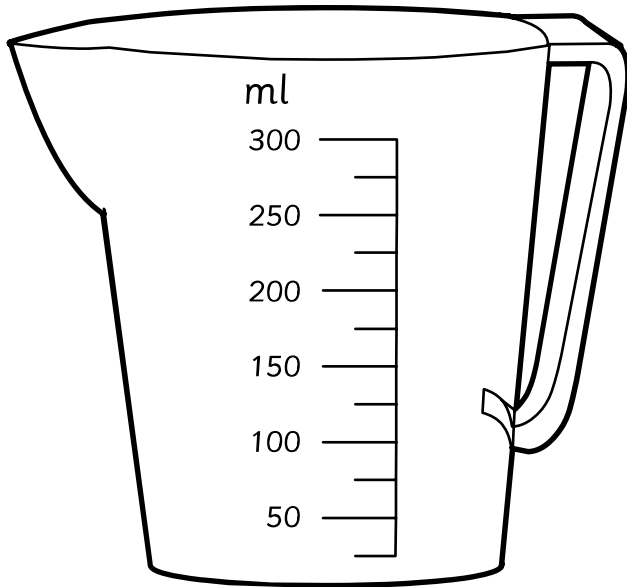

**volume**

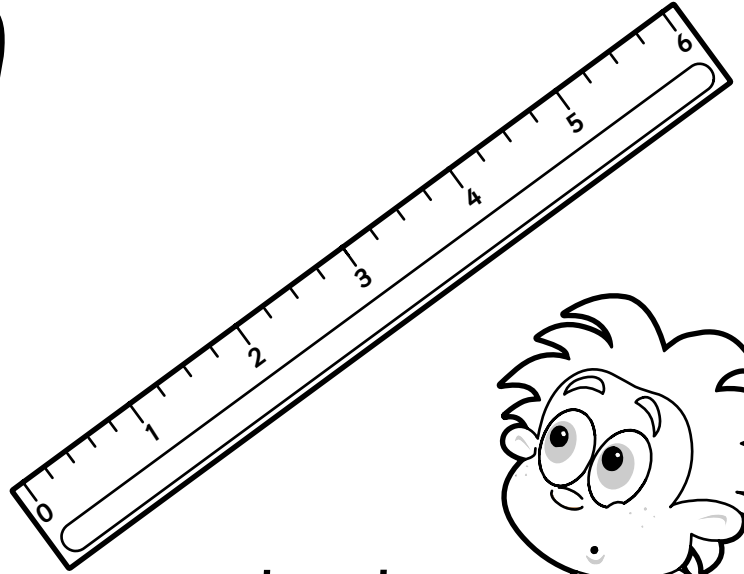

**length**



Circle the item that is longer.

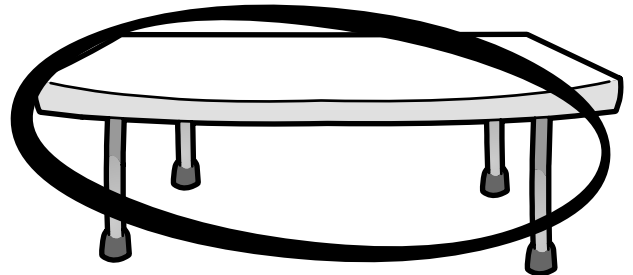
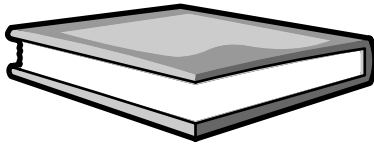

Circle the item that is heavier.

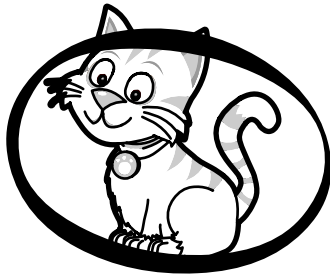

Circle the item that has more volume.

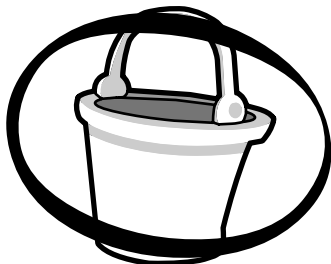



# One, Two, Bee

## Activity Sheet

Name: \_\_\_\_\_ Class: \_\_\_\_\_

How many bees in all?  
Write the number in the box.

**1**

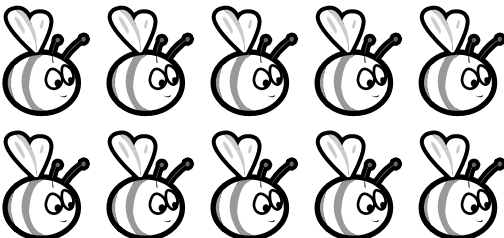

10

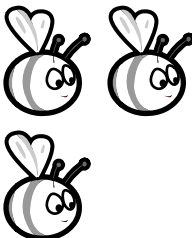

3

+ =

**2**

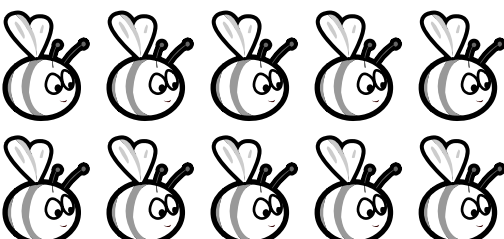

10

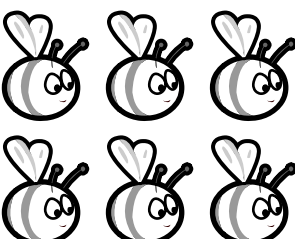

6

+ =

**3**

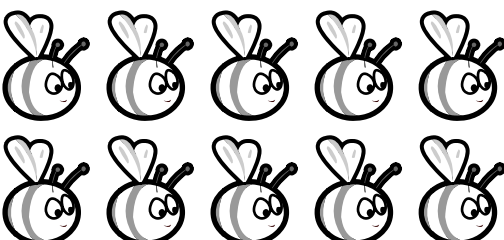

10



2

+ =

**4**

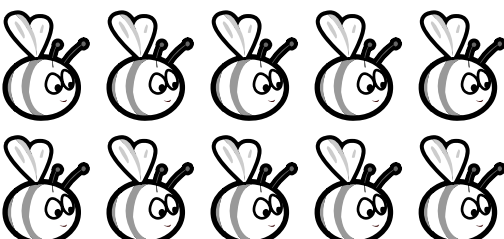

10

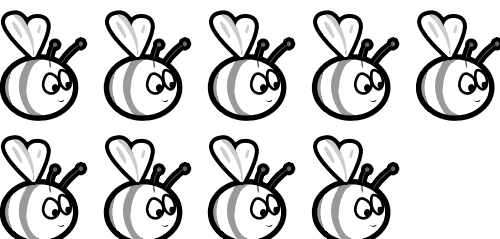

9

+ =

**5**

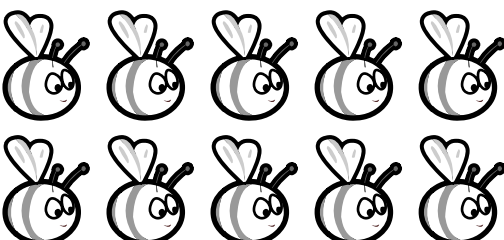

10

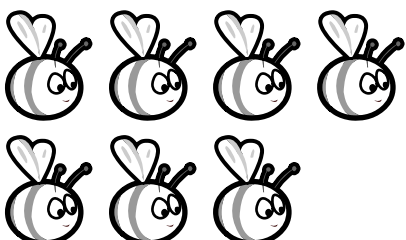

7

+ =

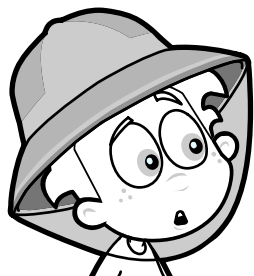



# One, Two, Bee - Answer Key

## Activity Sheet

Name: \_\_\_\_\_ Class: \_\_\_\_\_

How many bees in all?  
Write the number in the box.

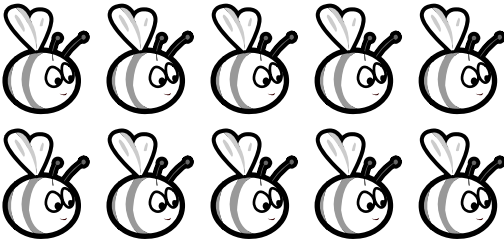
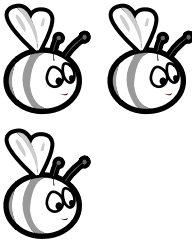

**1**

 $10$ 

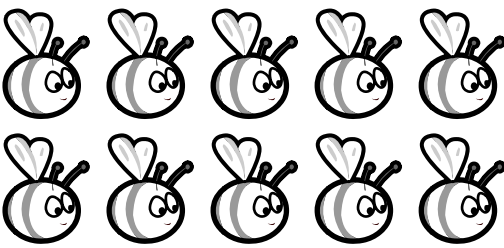
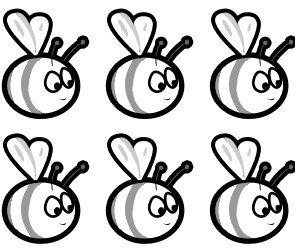
 $3$ 
 $+$ 
 $=$ 
**13**

**2**

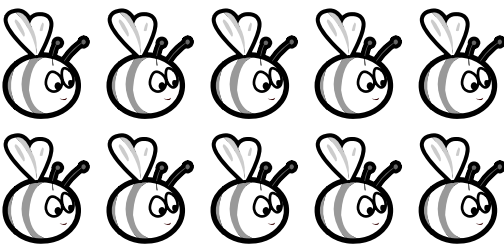
 $10$ 

 $6$ 
 $+$ 
 $=$ 
**16**

**3**

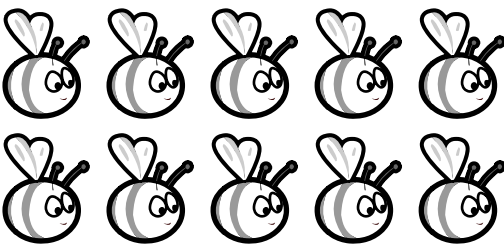
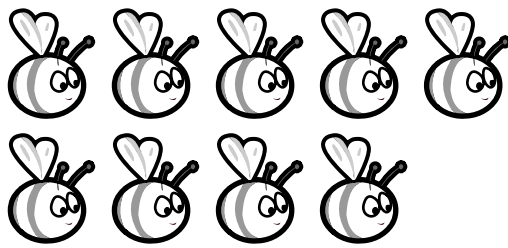

 $10$ 

 $2$ 
 $+$ 
 $=$ 
**12**

**4**

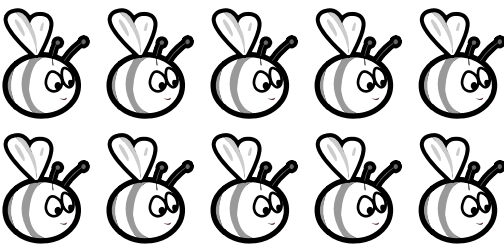
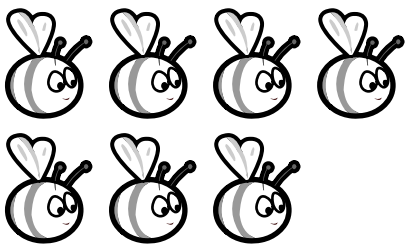
 $10$ 

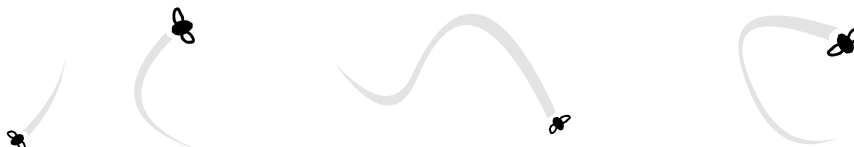
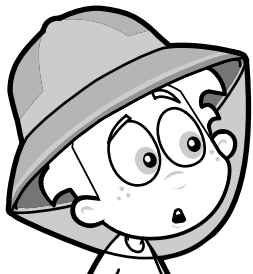
 $9$ 
 $+$ 
 $=$ 
**19**

**5**

 $10$ 

 $7$ 
 $+$ 
 $=$ 
**17**





# Round About

Activity Sheet

Name: \_\_\_\_\_ Class: \_\_\_\_\_

Paste the shapes to finish the picture.

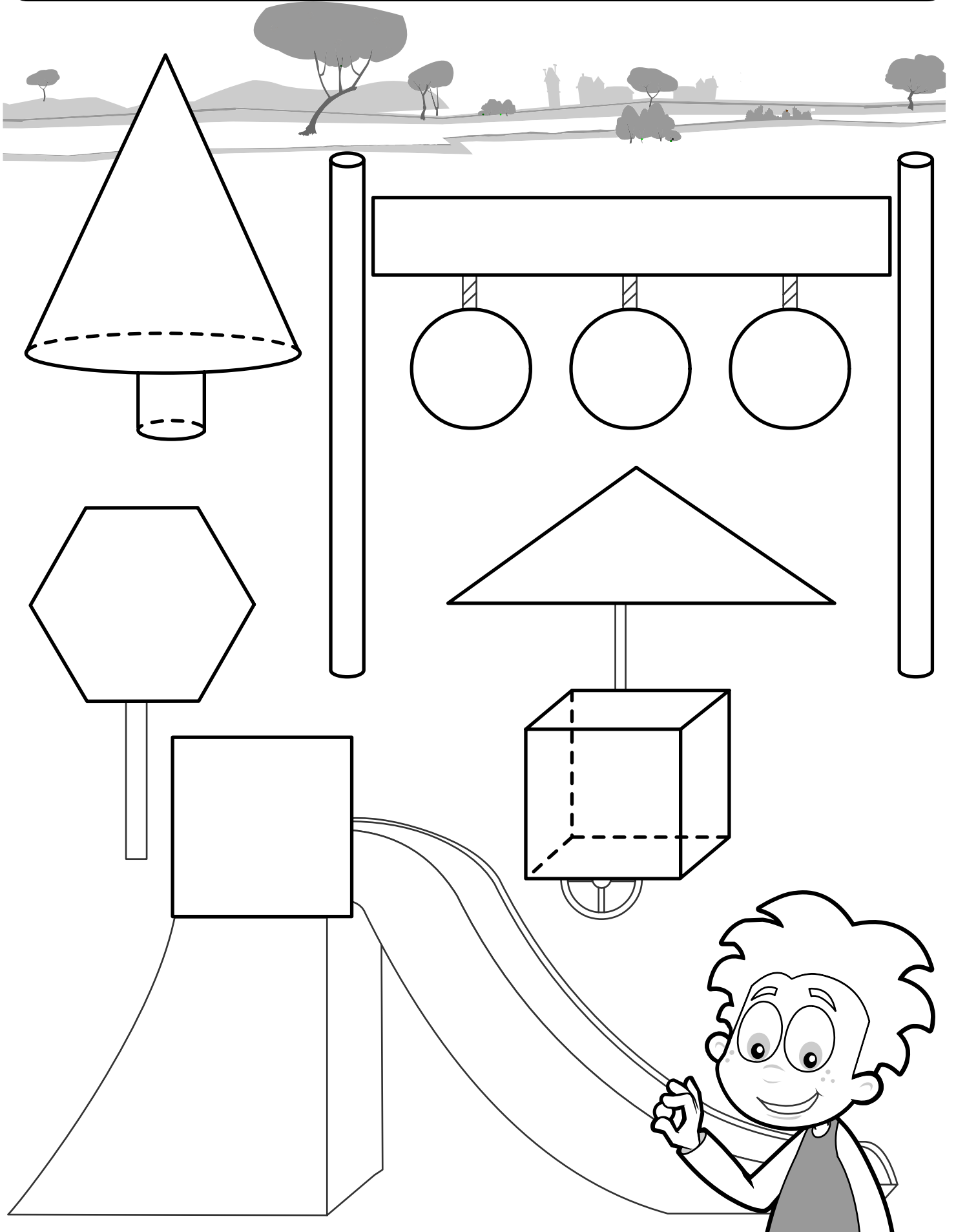



# Round About

Activity Sheet

Name: \_\_\_\_\_ Class: \_\_\_\_\_

Color and cut out the shapes.

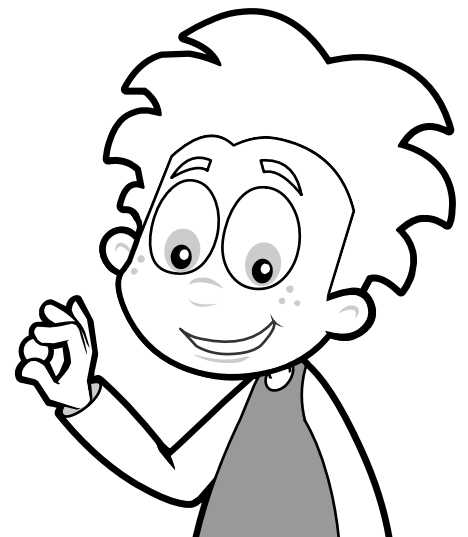
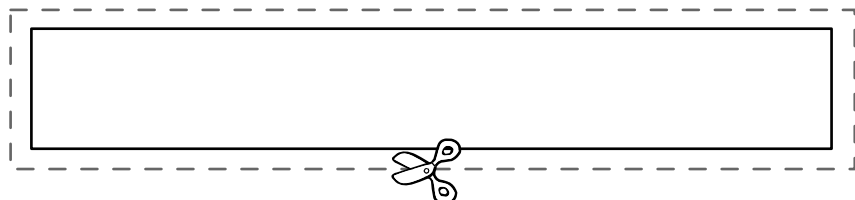
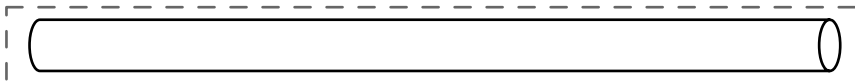
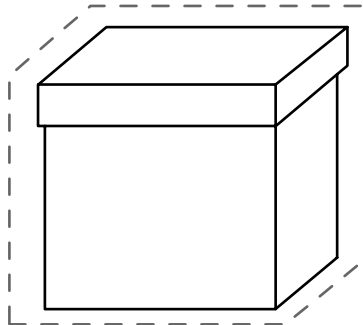
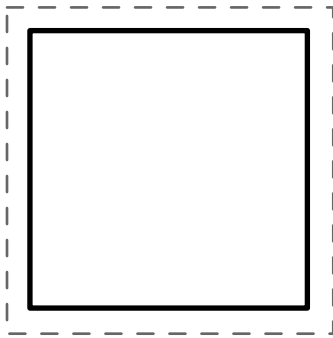
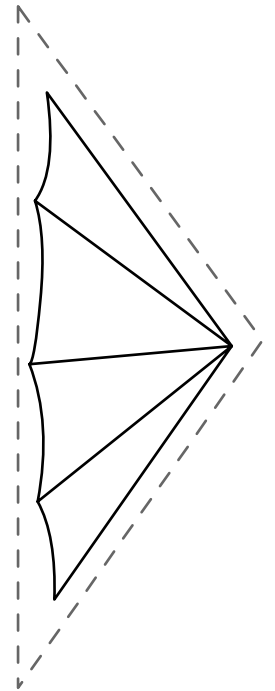
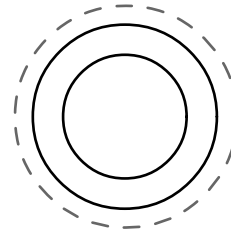
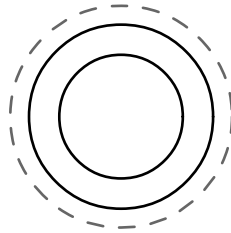
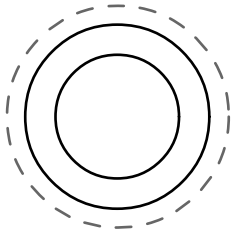
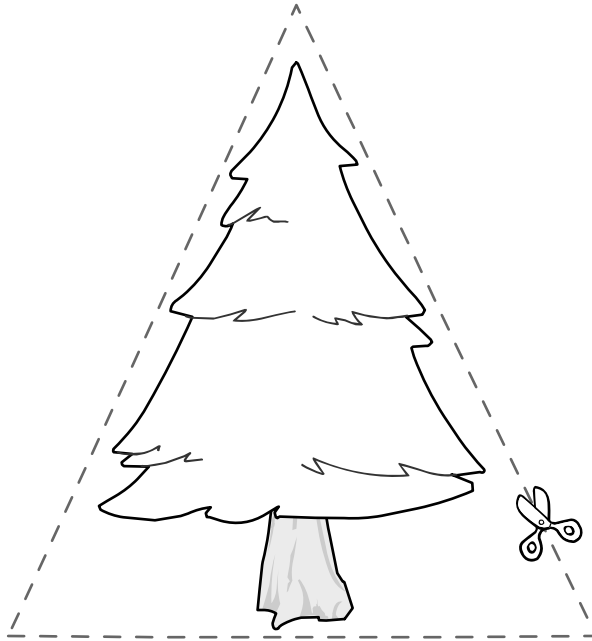





# Round About - Answer Key

## Activity Sheet

Name: \_\_\_\_\_ Class: \_\_\_\_\_

Paste the shapes to finish the picture.

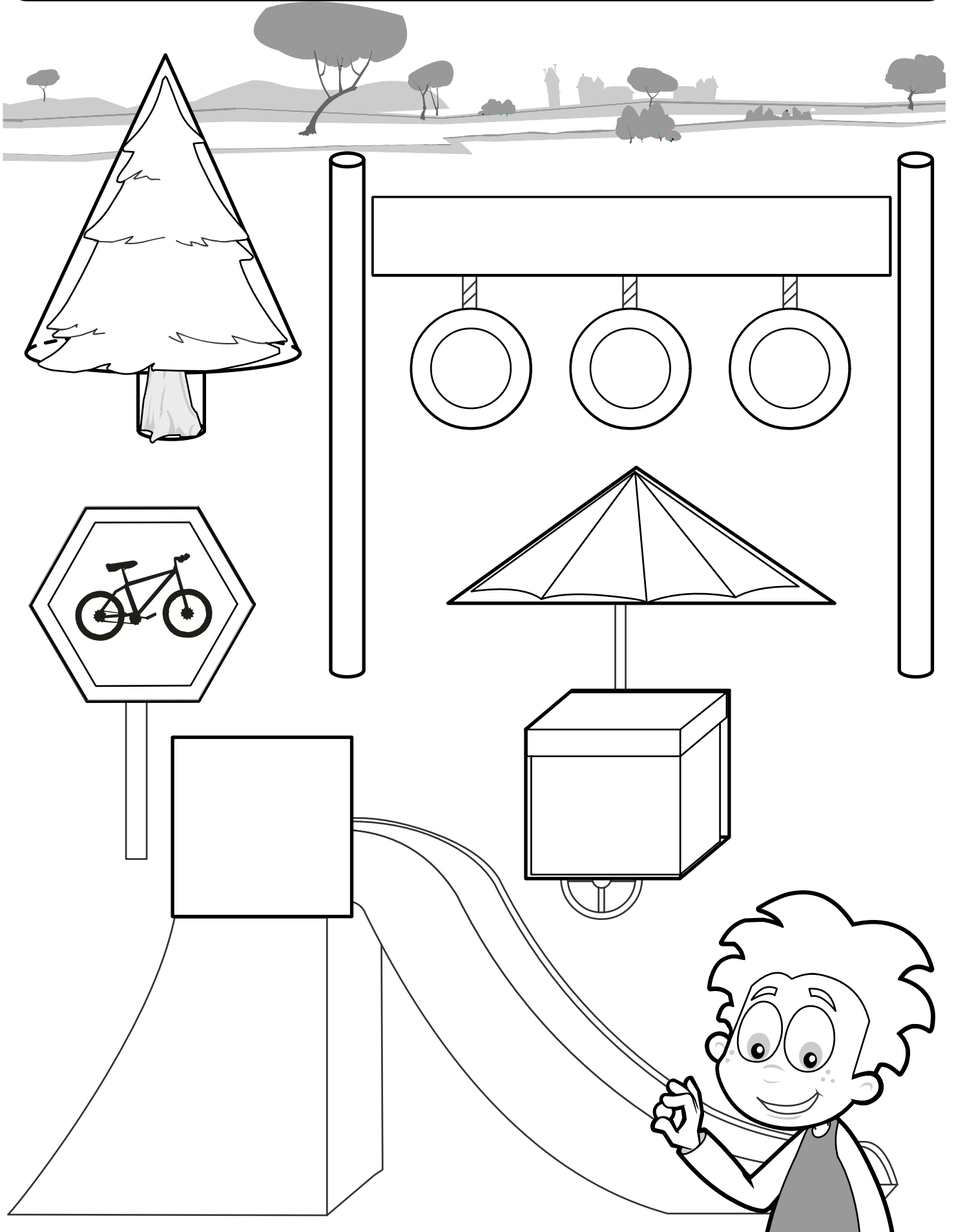



Name: \_\_\_\_\_ Class: \_\_\_\_\_

Draw a line in the large shape to separate it into the two different, smaller shapes.

1 Draw a line to show a  and a  inside the shape.

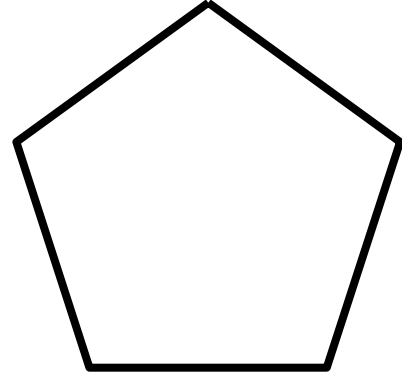

1 Draw a line to show two  inside the shape below.

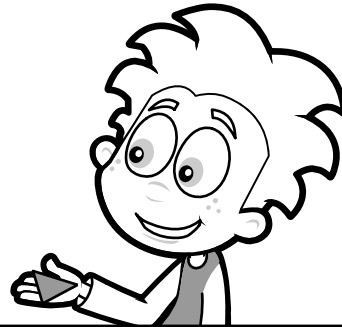
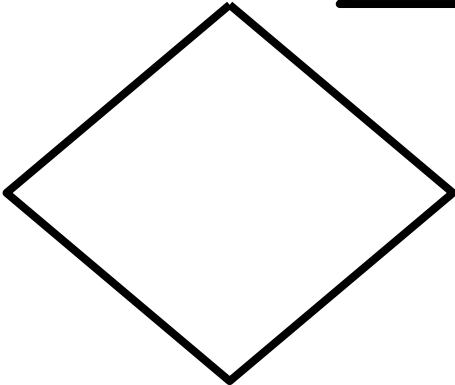

Use shapes you know to draw a picture.



# Snip Shape - Answer Key

## Activity Sheet

Name: \_\_\_\_\_ Class: \_\_\_\_\_

Draw a line in the large shape to separate it into the two different, smaller shapes.

1 Draw a line to show a  and a  inside the shape.

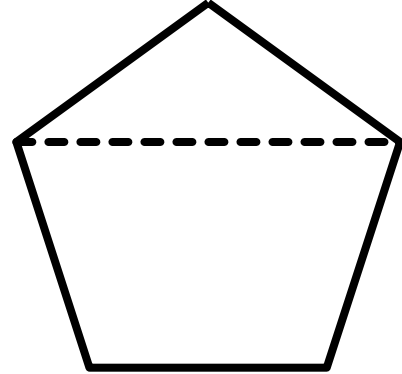

1 Draw a line to show two  inside the shape below.

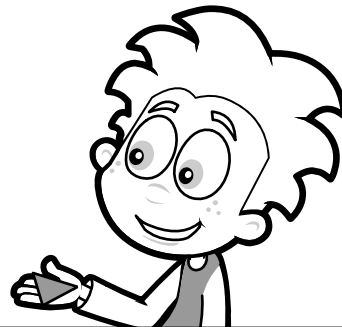
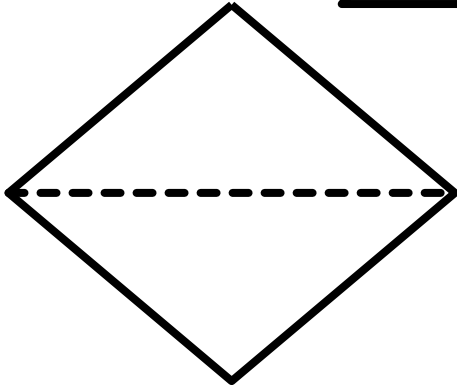

Use shapes you know to draw a picture.

Accept all reasonable responses

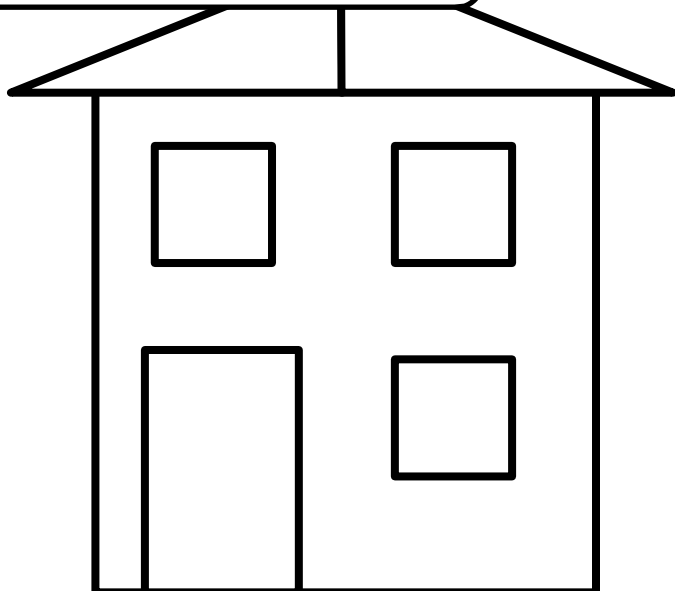
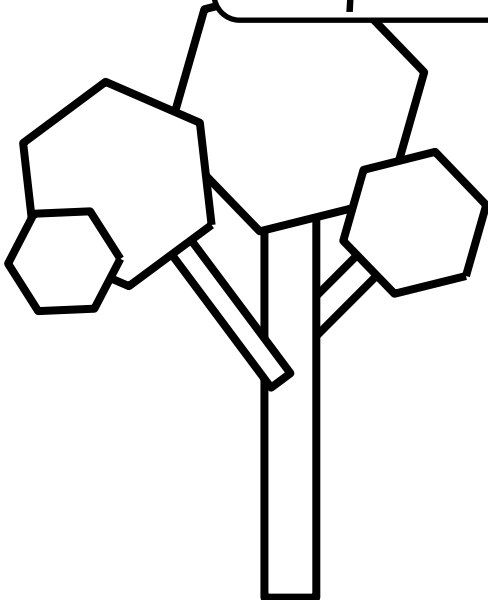



# Reading and Literacy

# on

Name \_\_\_\_\_

## Sight words

### Lesson 29 • Worksheet 1

1 Write the word.

on

on

on

on

on

on

2 Complete the sentences with a word from the box

in on at



The bee is \_\_\_\_\_ the flower.

See a rat \_\_\_\_\_ a hat.

I am \_\_\_\_\_ school.



Name \_\_\_\_\_

# on

Lesson 29 • Worksheet 2

## Read and write

1 Read the sentence and draw a picture.



Sam the ant is  
on the mat.



Zee is a bee.

2 Write a sentence for each picture.



---

---

---

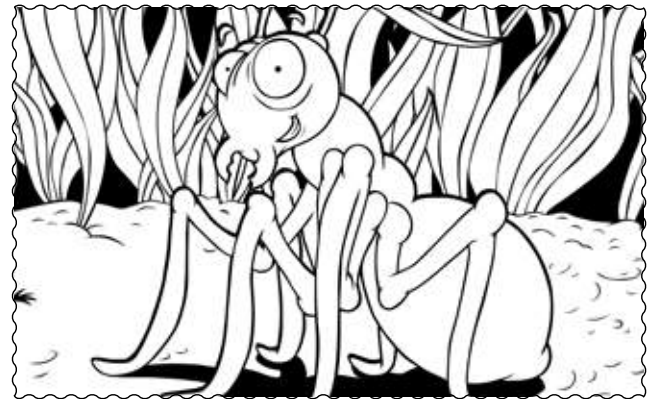

---

---

---

# Initial sounds

Name \_\_\_\_\_

## Lesson 29 • Worksheet 3

Make words. Match to a picture.

d

and



b

an



t

ad

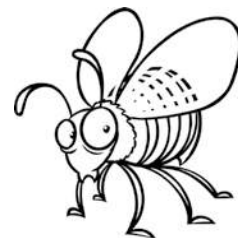

f

ap

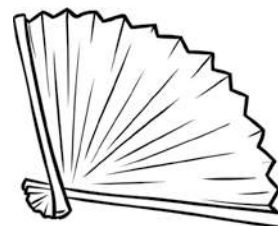

h

ee



Name \_\_\_\_\_

# Word families

Lesson 29 • Worksheet 4

Name each picture. Write the word.

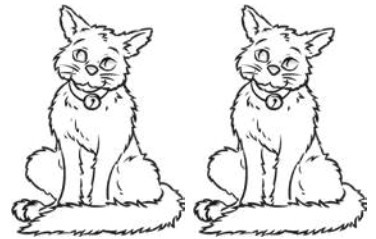
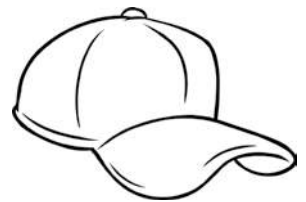
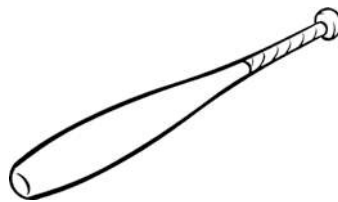
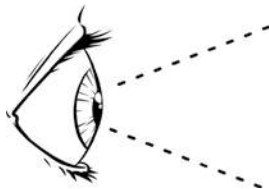
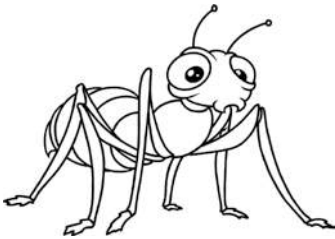
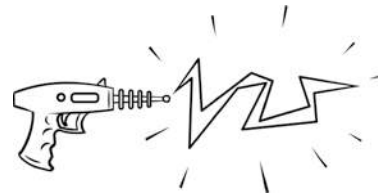
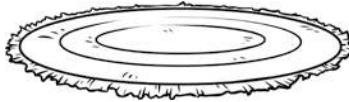
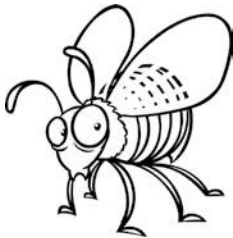



# he she

Name \_\_\_\_\_

## Sight words

### Lesson 33 • Worksheet 1

1 Trace the words.

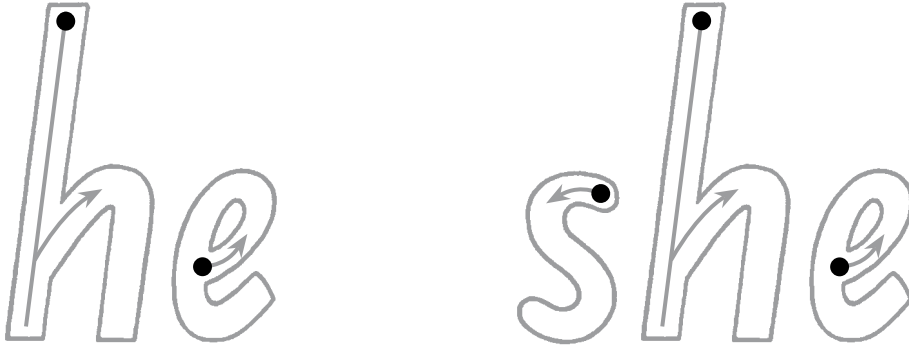

2 Complete the words.

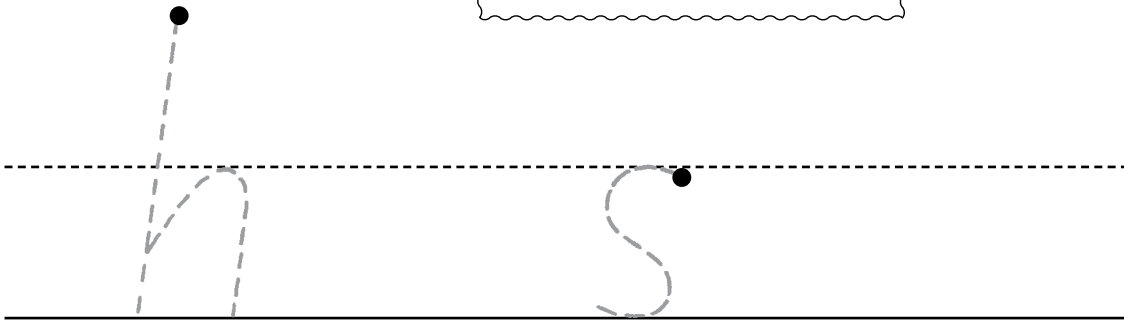
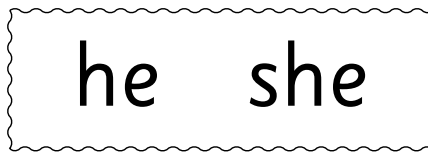

3 Match the word to its picture.

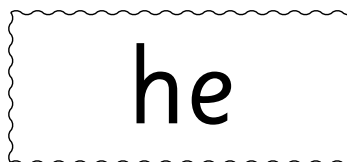

Name \_\_\_\_\_

# Read

Lesson 33 • Worksheet 2

## Read

Look at the picture. Color the right ending for the sentence. Read each sentence.

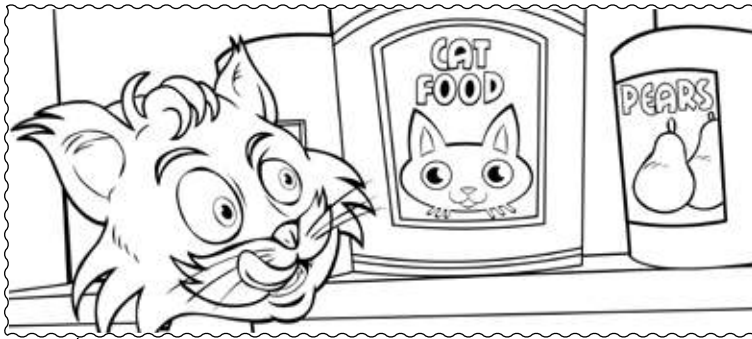

The cat can see

a cat on a can.

a man on a can.

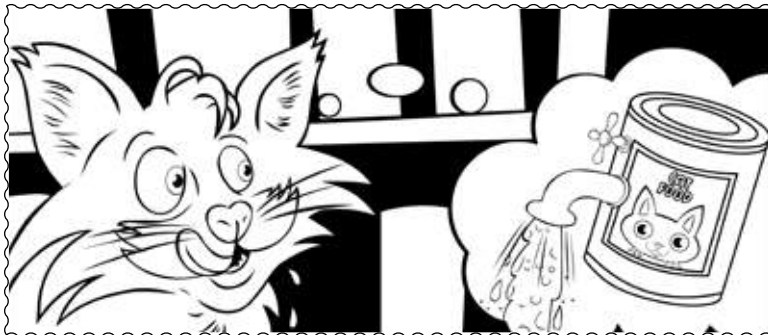

The cat can see

jam in a can.

a tap on the can.

# at

Name \_\_\_\_\_

## Word family

### Lesson 33 • Worksheet 3

Match the words to their pictures.



bat

rat

cat



map

tap

lap



can

man

fan



ham

Sam

jam



sat

mat

hat

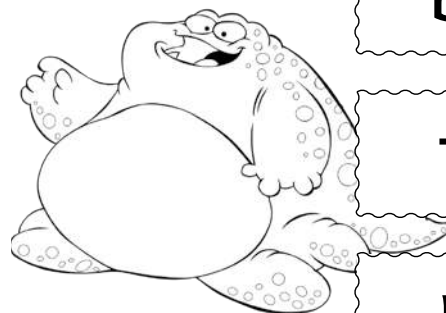

bat

fat

rat

Name \_\_\_\_\_

# he she

Lesson 33 • Worksheet 4

## Check

1 Color **he** = red, **she** = yellow.

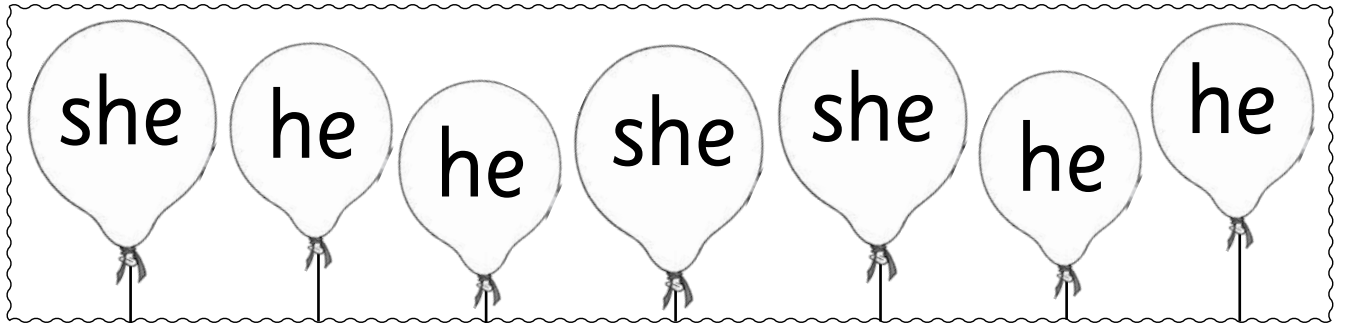

2 Complete the sentence.

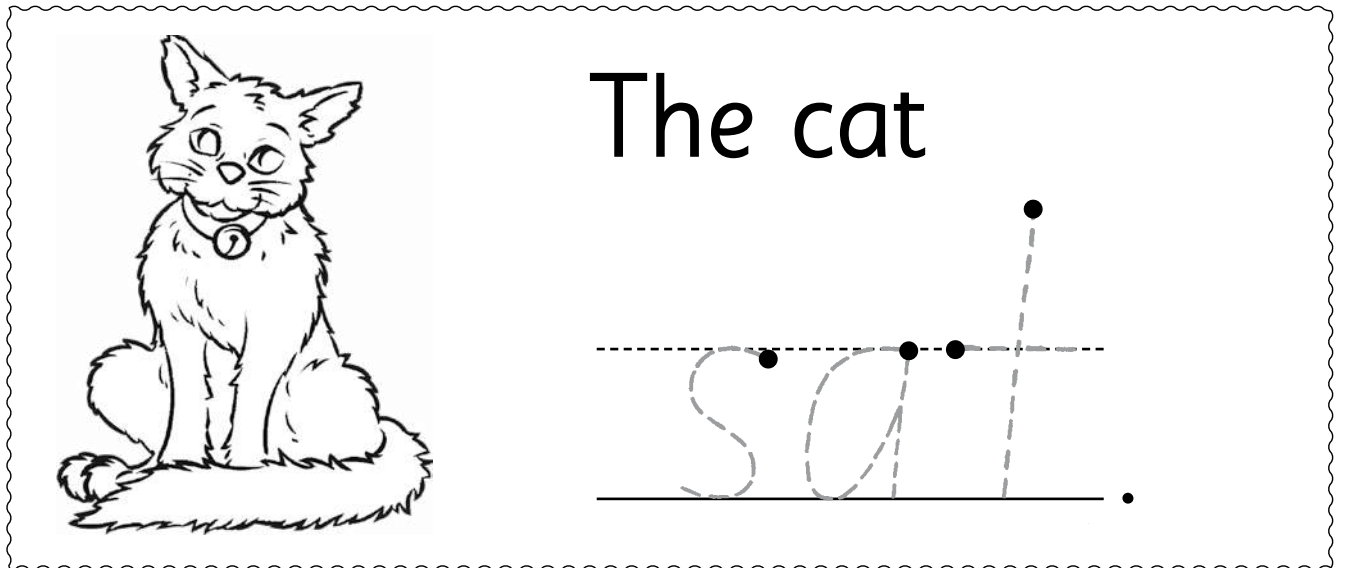

2 Read the sentence. Draw a picture.

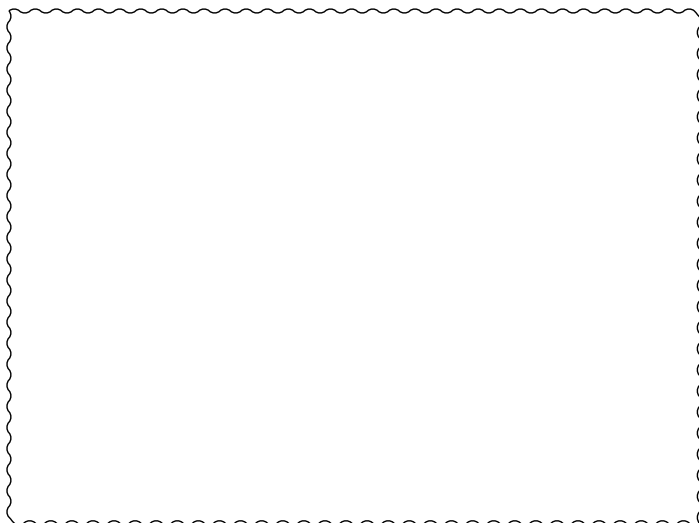

He is a fat cat.

# Sight words

Name \_\_\_\_\_

## Lesson 35 • Worksheet 1

1 Trace the words.

as has

2 Color **as** = blue **has** = yellow.

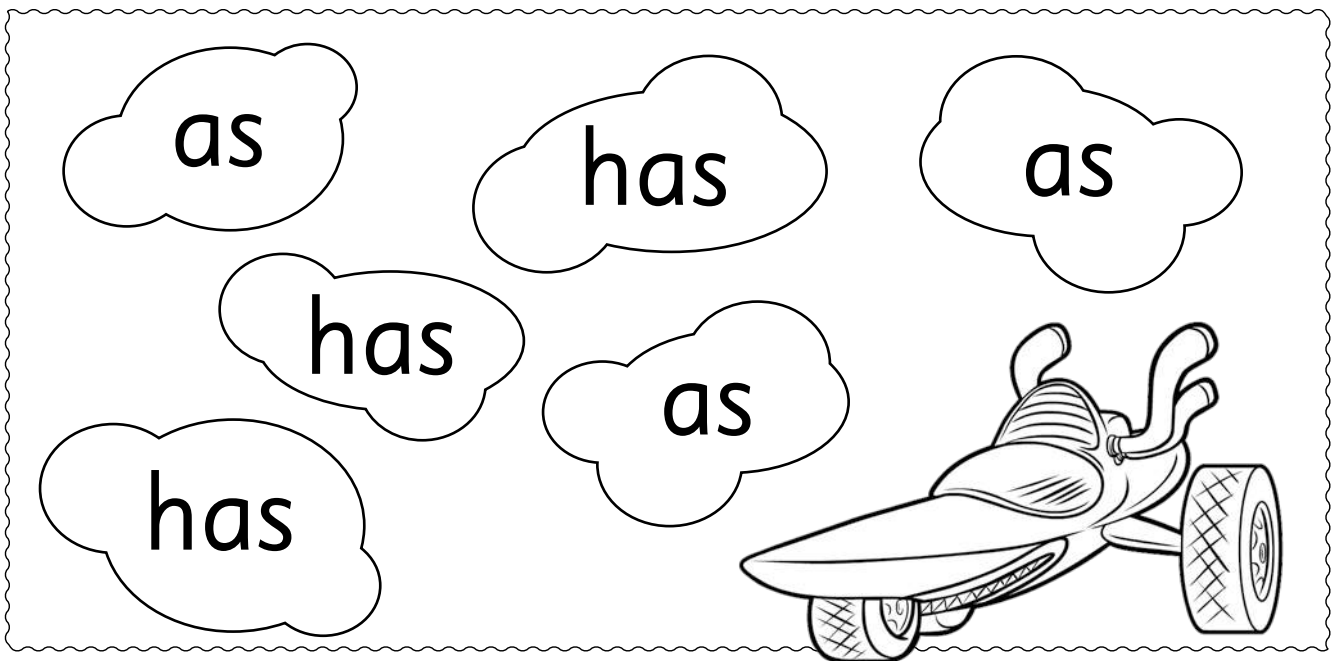

3 Guess the word by its shape. Write each word in the boxes.

as has

|  |  |  |
|--|--|--|
|  |  |  |
|--|--|--|

|  |  |
|--|--|
|  |  |
|--|--|

Name \_\_\_\_\_

# Read

## Lesson 35 • Worksheet 2

Draw:

a fan on the cat.



a tap on the can.



a man on the map.



a rat on the mat.

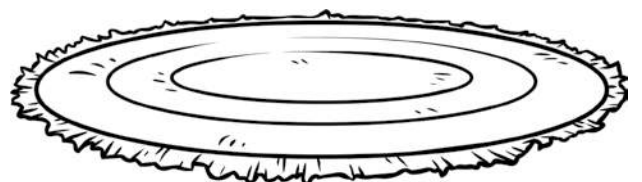

# Word families

Name \_\_\_\_\_

am, ap, at, an

## Lesson 35 • Worksheet 3

1 Match the words to their pictures.

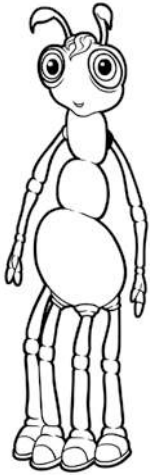

ham

jam

Sam

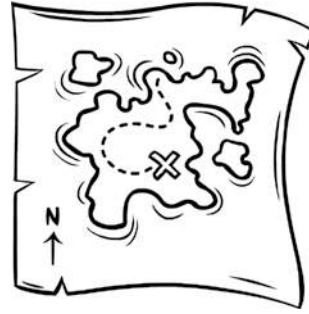

cap

map

tap

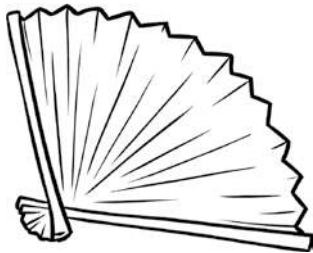

fan

man

pan



fat

hat

rat

2 Color the odd one out in each row.

fan

man

ran

cat

cap

tap

ham

map

pan

ham

Sam

jam

cat

can

mat

hat

1 Join the words that rhyme.

|     |     |
|-----|-----|
| map | mat |
| fat | tap |
| ham | man |
| can | jam |

*(Note: A dashed line connects 'map' to 'tap'.)*

2 Color the correct word. Cross out the wrong word.

She   a map.

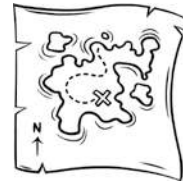

I am   good as Sam.



3 Say the name of each picture. Color its end sound.

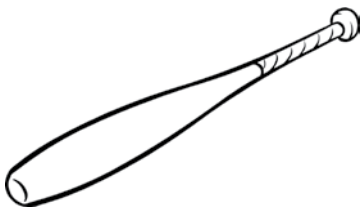

|    |    |    |    |
|----|----|----|----|
| ap | an | at | am |
|----|----|----|----|

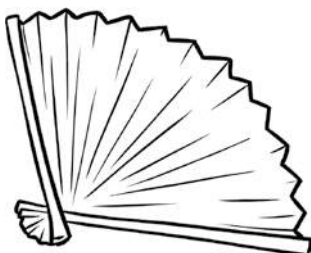

|    |    |    |    |
|----|----|----|----|
| ap | an | at | am |
|----|----|----|----|



# yes you

Name \_\_\_\_\_

## Sight words

Lesson 37 • Worksheet 1

1 Trace the words.

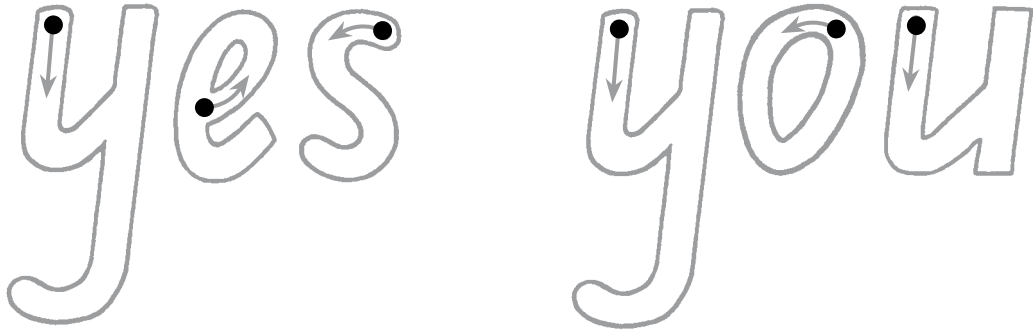

2 Complete the words **yes** and **you**.

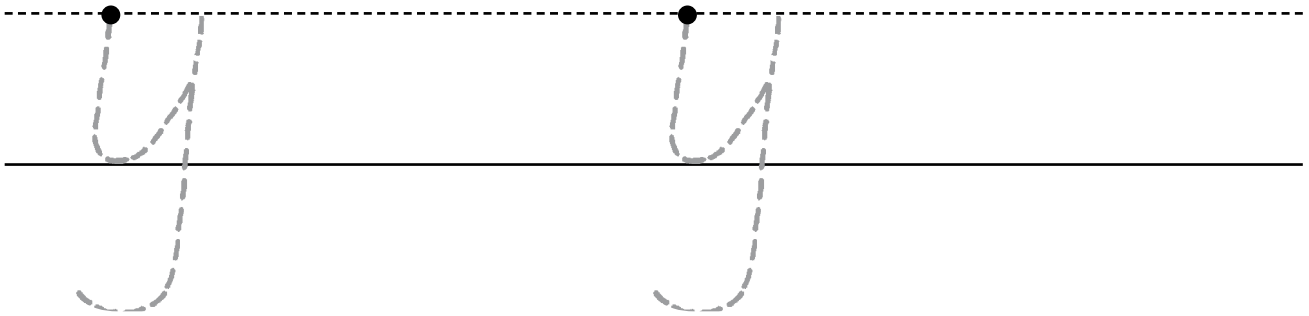

3 Color **you** = red **yes** = yellow.

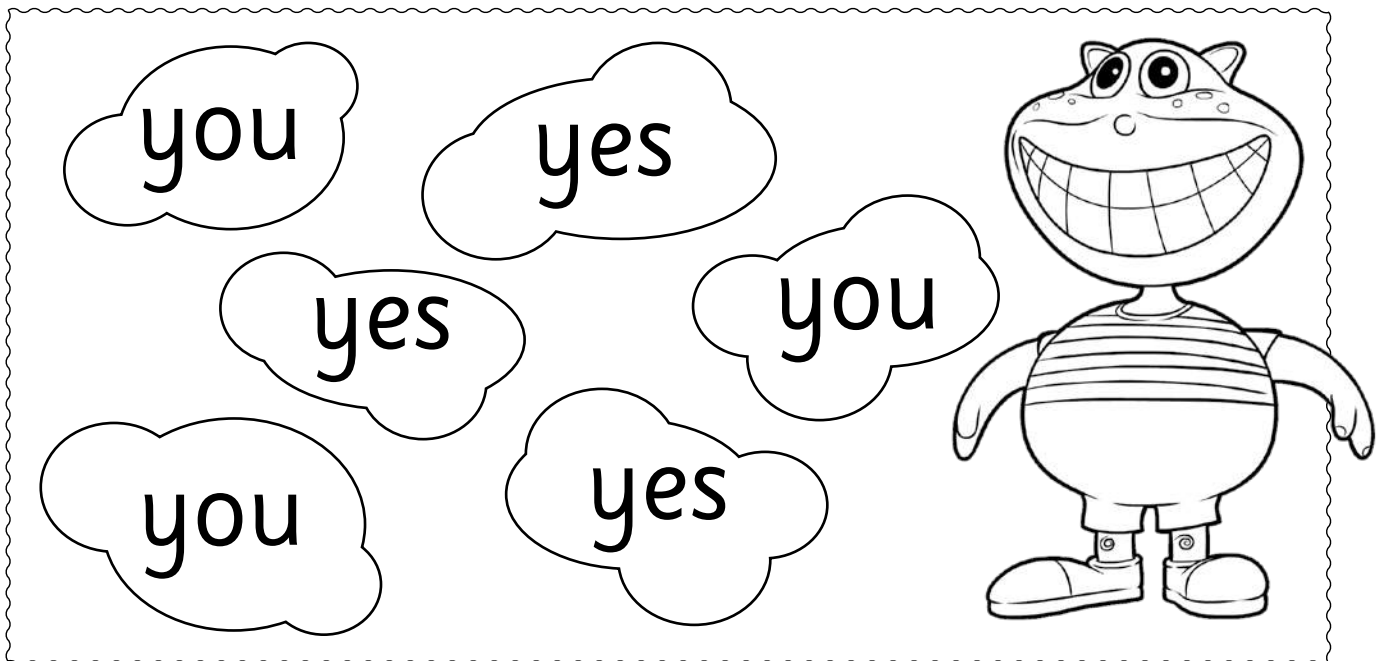

Name \_\_\_\_\_

## Read

Finish each sentence with a word from the box. Read each sentence.

cat map van

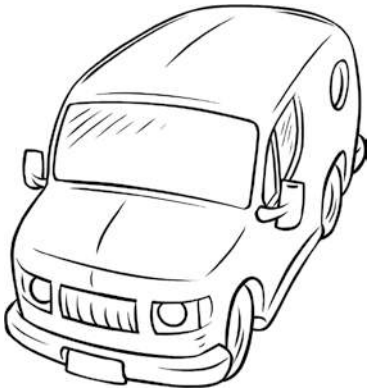

Dan has a

-----  
\_\_\_\_\_.



Dan has a

-----  
\_\_\_\_\_.



Dan has a

-----  
\_\_\_\_\_.

1 Color the pairs that rhyme.

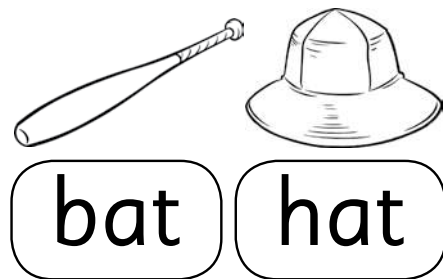
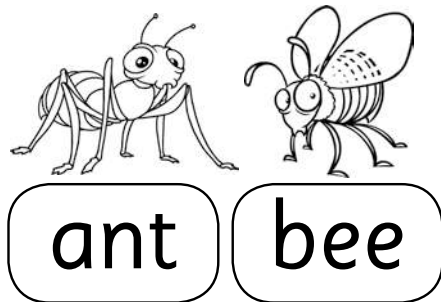
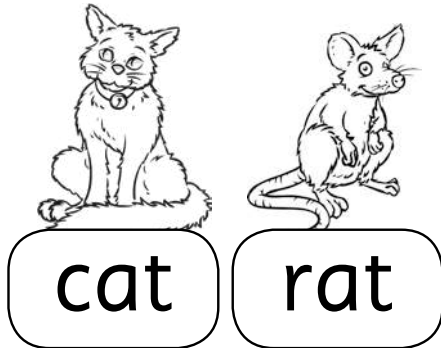

3 Use the wheels to make words. Write the words.

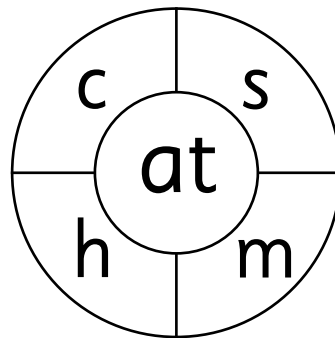
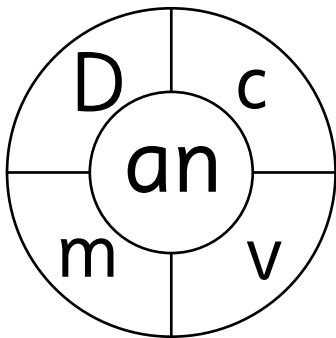

Name \_\_\_\_\_

## Check

1 Write each word in the correct boxes.

yes ant van you

|  |  |  |
|--|--|--|
|  |  |  |
|--|--|--|

|  |  |  |
|--|--|--|
|  |  |  |
|  |  |  |

|  |  |  |
|--|--|--|
|  |  |  |
|  |  |  |

|  |  |  |
|--|--|--|
|  |  |  |
|  |  |  |

2 Join the jigsaw pieces. Write the word.

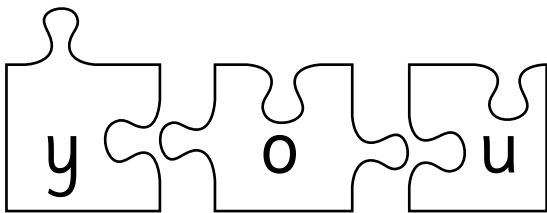

\_\_\_\_\_

3 Complete the sentence.



Dan has an

ant.

# Review

Name \_\_\_\_\_

## Word families

### Lesson 40 • Worksheet 1

1 Draw lines to match words that rhyme.



2 Color the odd one out in each row.

ran

man

pat

can

mad

bad

had

van

zap

dam

jam

ham

hat

can

bat

sat

tap

map

rat

gap

Name \_\_\_\_\_

# Review

Lesson 40 • Worksheet 2

## Read

Match to a picture.



The fish has  
a tin.

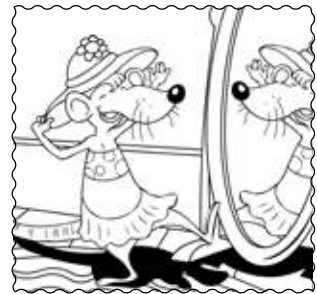

Dan has an ant  
in a hat.



A rat has  
a hat.



The cat can see  
a cat on a can.



# Review

Name \_\_\_\_\_

## Sight words

### Lesson 40 • Worksheet 3

1 Trace and write the words.

he

\_\_\_\_\_

the

\_\_\_\_\_

she

\_\_\_\_\_

2 Join Sandy Can to the word **can**.



can

no

yes

can

can

can

on

3 Write the words in the correct box.

|                                    |                |                |
|------------------------------------|----------------|----------------|
| as you<br>has man<br>yes see<br>in | 2 letter words | 3 letter words |
|------------------------------------|----------------|----------------|

Name \_\_\_\_\_

# Review

Lesson 40 • Worksheet 4

## Check

- 1 Circle the pictures that start with the letter.

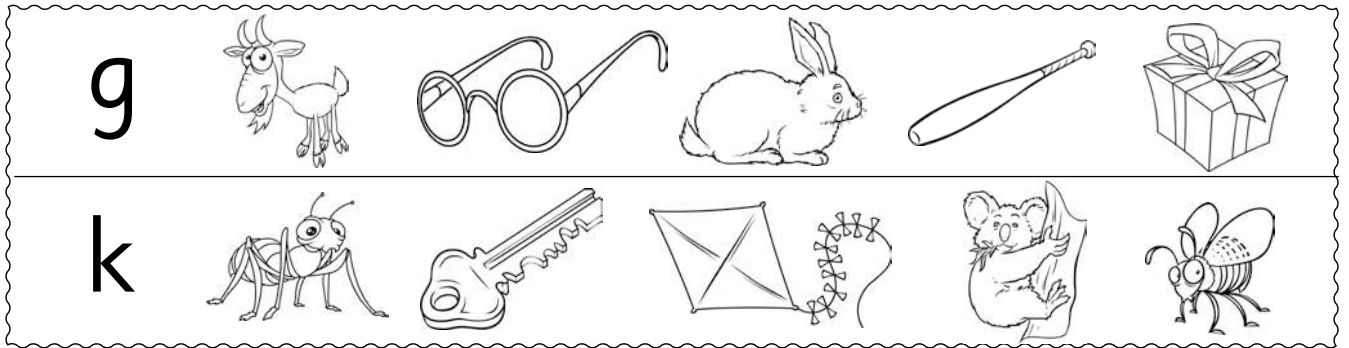

- 2 Write each word in a box.

has see

|  |  |  |
|--|--|--|
|  |  |  |
|--|--|--|

|  |  |  |
|--|--|--|
|  |  |  |
|--|--|--|

- 3 Draw a picture for each sentence.

The fish  
has a fin.

The cat can  
see the fish.



## Word families

### Lesson 44 • Worksheet 1

1 Match each picture to a word.

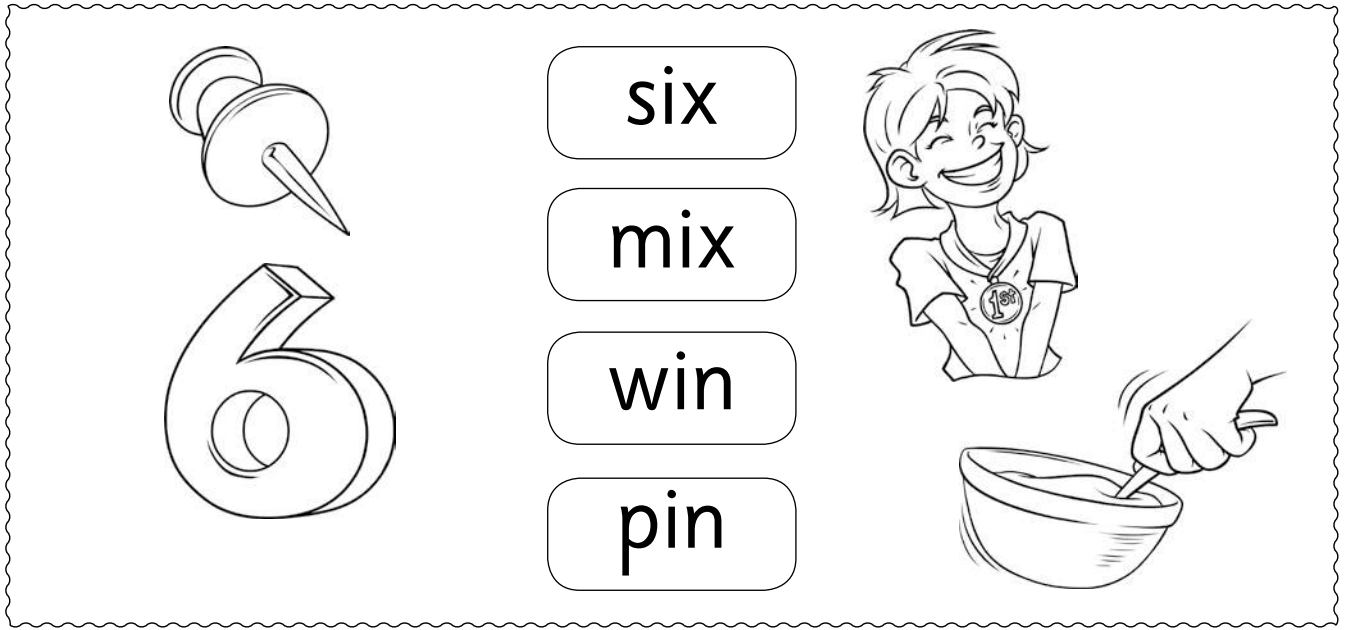

ix  
mix  
win  
pin

2 Write the words on the correct tin.

fix win  
bin six  
mix pin



3 Complete each word family.

six   
f \_\_\_\_\_  
m \_\_\_\_\_

pin   
b \_\_\_\_\_  
t \_\_\_\_\_

Name \_\_\_\_\_

**ix in**

Lesson 44 • Worksheet 2

## Read and write

1 Draw a picture for each sentence.

I can see six  
blue birds.

I can see six  
red rabbits.

2 Complete the sentences.

see can six

I \_\_\_\_\_ see six pigs.

You can \_\_\_\_\_ six bats.

He can see \_\_\_\_\_ fish.

## Sight words

### Lesson 44 • Worksheet 3

1 Trace and write the words.

you can see

\_\_\_\_\_

2 Help Itsy Bitsy see the blue birds. Color the path of **see** words.

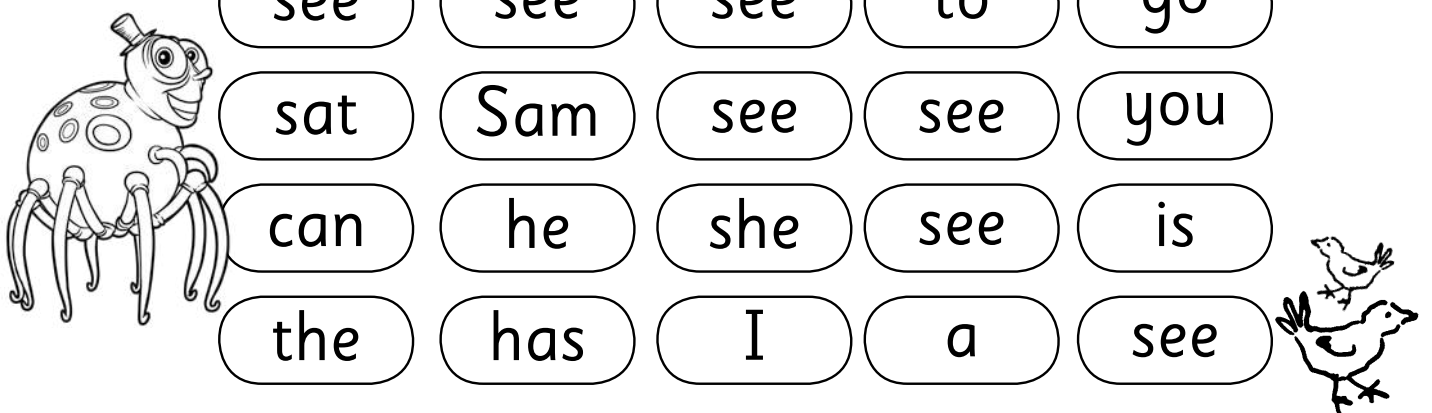

|     |     |     |     |     |
|-----|-----|-----|-----|-----|
| see | see | see | to  | go  |
| sat | Sam | see | see | you |
| can | he  | she | see | is  |
| the | has | I   | a   | see |

3 Write each word in a box.

you can see

|  |  |  |
|--|--|--|
|  |  |  |
|--|--|--|

|  |  |  |
|--|--|--|
|  |  |  |
|--|--|--|

|  |  |  |
|--|--|--|
|  |  |  |
|--|--|--|

Name \_\_\_\_\_

# ix in

Lesson 44 • Worksheet 4

## Check

- 1 Find the words. Color **you** = blue, **can** = red, **see** = green.

|   |   |   |   |   |   |   |   |   |
|---|---|---|---|---|---|---|---|---|
| y | o | u | s | e | e | c | a | n |
| s | e | e | c | a | n | y | o | u |
| c | a | n | y | o | u | s | e | e |
| s | e | e | c | a | n | y | o | u |

- 2 Make a word with the letters on the fridge.

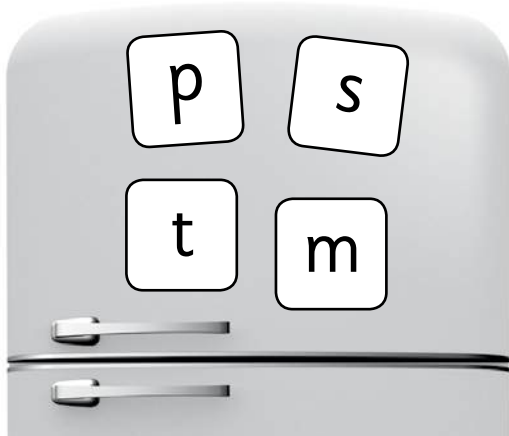

\_\_\_\_\_ix      \_\_\_\_\_in  
\_\_\_\_\_in      \_\_\_\_\_ix

- 3 Draw a picture for this sentence.

I can see six  
pink pigs.

## Word families

### Lesson 45 • Worksheet 1

1 Match each picture to a word.

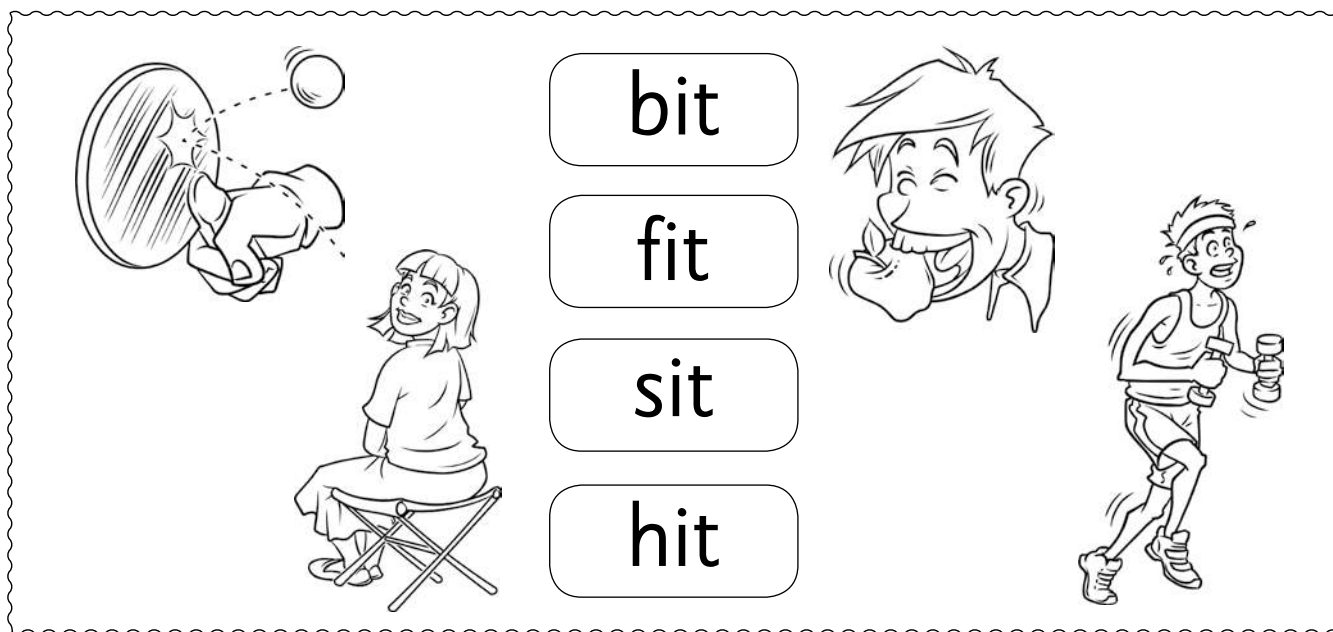

bit

fit

sit

hit

2 Color the **it** words blue. Color the **in** words red.

pin spin it tin sit

bit fit bin hit fin

3 Join each sound to the **it** machine.  
Write each word you make.

k s

f b

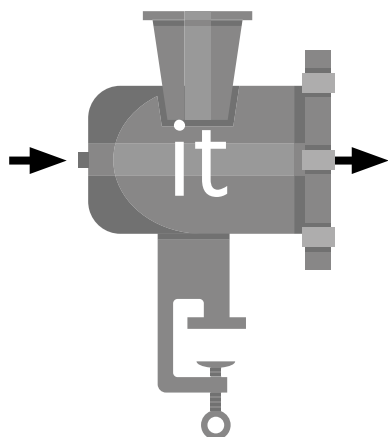

---

---

---

---

Name \_\_\_\_\_

## Read and write

Write each word. Read it and match to a picture.



sit



bit



hit



hit

Tick your best word.

# it

Name \_\_\_\_\_

## Sight words

### Lesson 45 • Worksheet 3

1 Trace and write the words.

*it spin swing*

2 Find the matching words.

it

spin

swing

spin

swing

it

swing

it

spin

3 Guess the word by its shape.  
Write each word in the boxes.

it spin swing

|  |  |  |  |
|--|--|--|--|
|  |  |  |  |
|  |  |  |  |
|  |  |  |  |

|  |  |  |  |  |
|--|--|--|--|--|
|  |  |  |  |  |
|  |  |  |  |  |
|  |  |  |  |  |

|  |  |
|--|--|
|  |  |
|  |  |
|  |  |

Name \_\_\_\_\_

# it

Lesson 45 • Worksheet 4

## Check

- 1 Use the wheel to make words.  
Write the words.

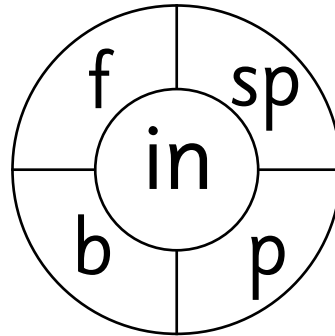
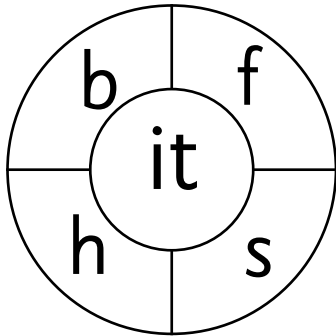

- 2 Color the correct word. Cross out the wrong word.

Can you  on it?

Can it  ?

We can  on it.

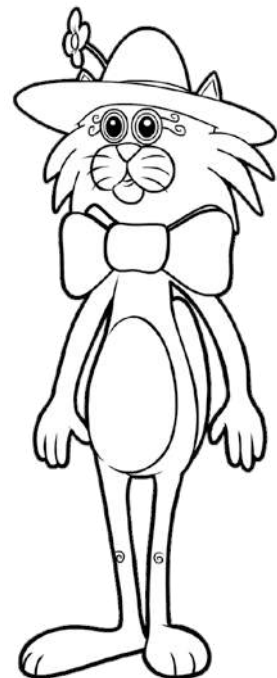



# ip

Name \_\_\_\_\_

## Word families

### Lesson 48 • Worksheet 1

#### 1 Trace.

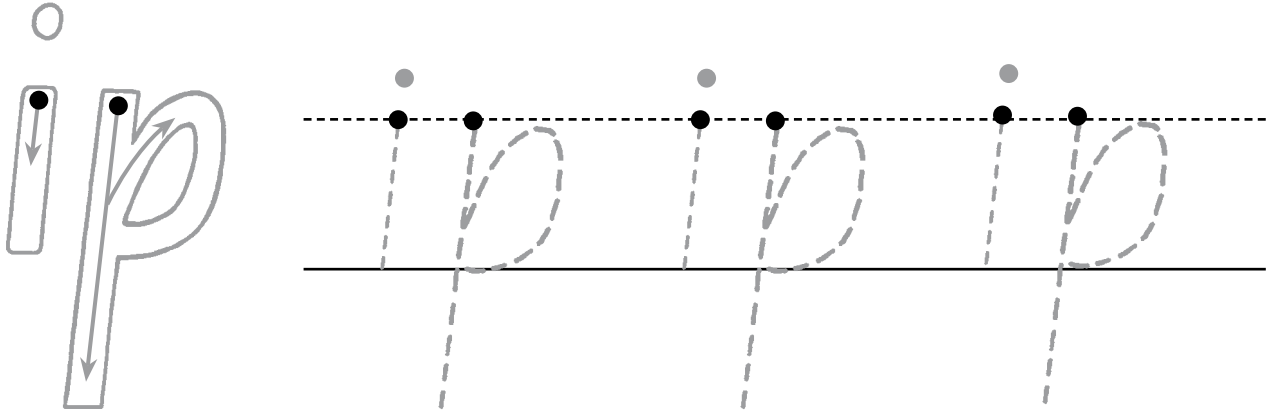

#### 2 Color the **ip** words.

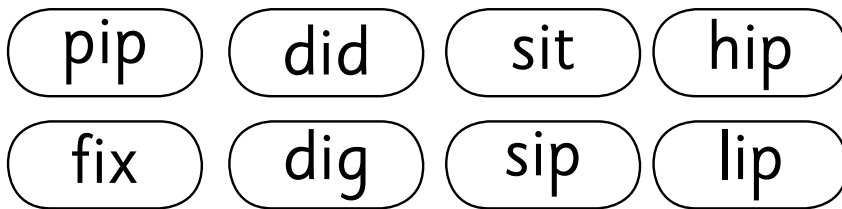

#### 3 Match each picture to a word.

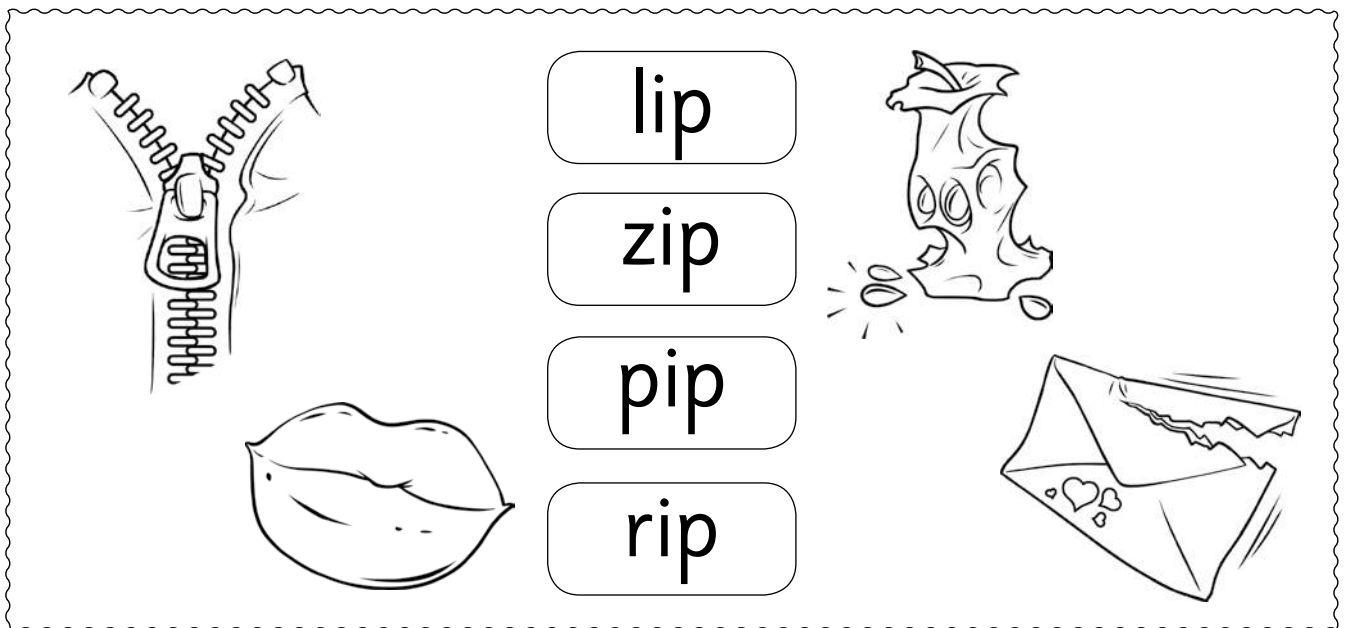

Name \_\_\_\_\_

# Read and write

Lesson 48 • Worksheet 2

Name each picture. Complete the sentence.

pig zip pip bin six

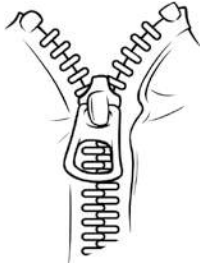

This is a \_\_\_\_\_.

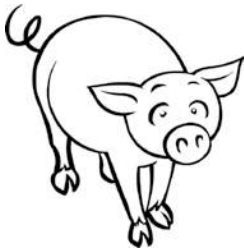

This is a \_\_\_\_\_.



This is a \_\_\_\_\_.



This is a \_\_\_\_\_.



This is a \_\_\_\_\_.

# Sight words

Name \_\_\_\_\_

## Lesson 48 • Worksheet 3

1 Trace and write the words.

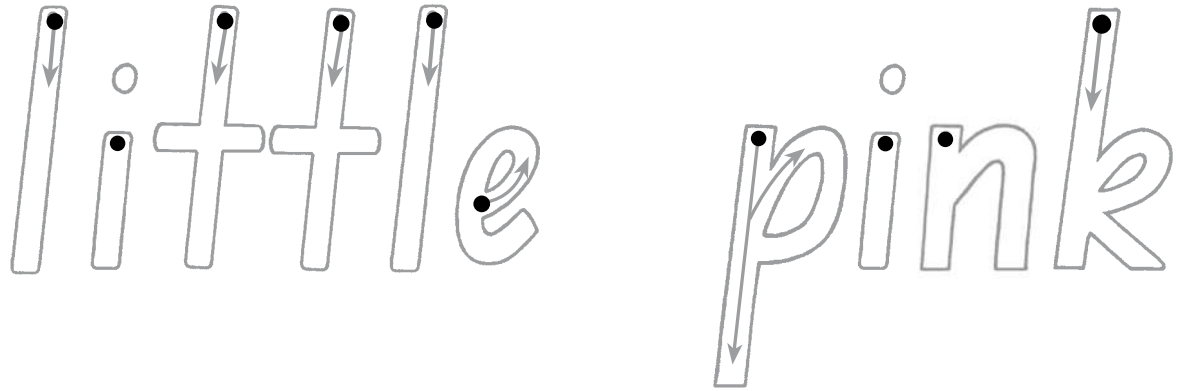

2 Help Thistle find his little cap. Color the path of **little** words.

|        |        |        |        |        |
|--------|--------|--------|--------|--------|
| little | yes    | is     | and    | he     |
| he     | little | little | she    | you    |
| she    | he     | little | little | little |
| you    | and    | is     | he     | little |

3 Guess the word by its shape. Write each word in a box.

little pink pig

|  |  |  |  |  |  |  |  |  |  |
|--|--|--|--|--|--|--|--|--|--|
|  |  |  |  |  |  |  |  |  |  |
|  |  |  |  |  |  |  |  |  |  |
|  |  |  |  |  |  |  |  |  |  |

Name \_\_\_\_\_

# ip

Lesson 48 • Worksheet 4

## Check

1 Label each picture. Use the words.

bin

win

sip

rip

pin

tin



\_\_\_\_\_

\_\_\_\_\_

\_\_\_\_\_

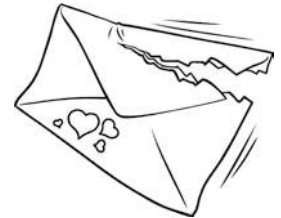

\_\_\_\_\_

\_\_\_\_\_

\_\_\_\_\_

2 Find the words. Color **little** = pink, **pip** = blue, **sip** = green.

|   |   |   |   |   |   |   |   |   |
|---|---|---|---|---|---|---|---|---|
| l | i | t | t | l | e | p | i | p |
| s | i | p | l | i | t | t | l | e |
| p | i | p | s | i | p | p | i | p |
| l | i | t | t | l | e | s | i | p |

3 Draw a picture for this sentence.

I can see  
six pips.