

For when you have to learn to
play the bass - RIGHT NOW!!!

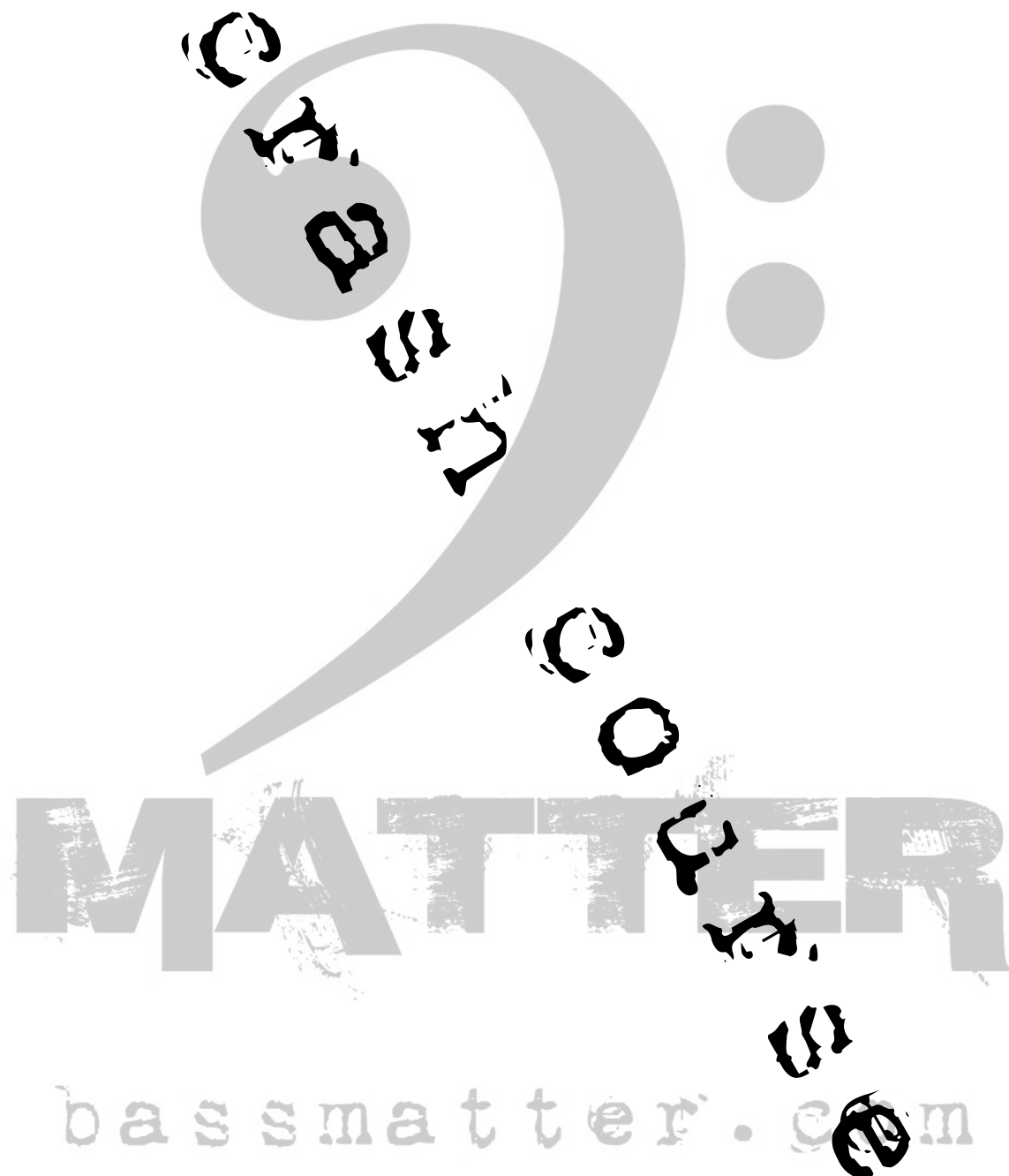

EMERGENCY USE ONLY

by ryan mcelelland

Hi!

Welcome! We're not going to waste any time with why this book was made, who we are or anything else.

We will, however, cover who this book is for. If you're any world famous bass player then we're glad you got this book. Thank you, now get back to work! Keep making stuff to inspire the rest of us to learn! *Newbies, those returning to the bass, people moving from guitar to bass in a band, or anyone that is under pressure to know what they are doing on the bass, and fast, pay attention!* The collection of material of this book is, in our opinion, the basics to playing bass guitar for some event. Pay attention, burn through this as fast as you can, and you're on your way. You'll develop style and technique as you go along.

Two Rules to Start

1- The bass player is the glue. There's plenty of debate about who keeps time and "leads" the band. Whatever, you keep it all together, play the root note and everyone else will pay attention to you to make sure they are playing the right chord. If the bass is on the wrong note, the whole sound can derail easily. Your job is vital but easy. Play the root note for the progression.



2- The bass player isn't noticed unless the bassist is not playing, or playing the wrong notes. Get it? If you're crazy on the bass, then you're no longer the glue, and eroding the foundation. If you are off, it's much better to quickly pause, listen and find your place again than scatter the wrong notes all over the place. Skilled bass players know when and where they can inject a tasty lick and not crash the whole band. You'll get there. Be the glue.



You are free to have different opinions on these points. When you get all pro and stuff you can make your own free book and teach the world how it really works.

To play the bass you need...

1- A bass. It doesn't really matter which one or what kind. If you plug it in to an amp and it makes noise when you hit the strings you're good.
(you will form a different opinion later)

2- Hands, all 10 fingers are recommended but not necessary. With enough skill and practice you could end up using all 10 in some fashion down the road.

3- Ears. One of the most overlooked parts of playing is listening to yourself. One ear will do, two is better.

4- Patch cord (1/4" cable) This is the cable that plugs into the bass then plugs into the amp. Something of decent length so you can stand and walk around a bit. 6 feet to 10 feet is a great place to start.

5- Amp. This is a variable place with many opinions. If you're looking to play on stage you need 100+ watts with a 12+ inch speaker. For practicing at home with no immediate ambitions to play, a practice bass amp found at any music store will do.

(Make sure you get a bass amp and not a guitar amp)

6- Some way to tune your bass. This is most easily done with a tuner. You can move on to tuning forks, harmonic tuning, and variable instrument tuning later. Spend \$20 and get a tuner.

(Bass Tuning is EADG for a 4 string)

7- You need to be able to count to 4. *(1,2,3,4 OR One Two Three Four)*



You may not be able to acquire all of these things at once. Step one is kind of the most important one.

Spend time learning your gear. What the knobs do on your bass and on the amp. How to tune. You may need to read instruction manuals, go to a music store, and ask other players. We won't cover it here due to time.



MATTER

How to Hold Your Bass

(All instructions are for right handed players. Lefties, south-paws and such please reverse instructions)

The Neck goes in left hand. Body of bass is under the right hand. The height of the bass should be comfortable. Some suggest a high sitting position with the bass resting on your chest, some over your abdomen, some below the waist. Much of this is preference for comfort AND for looks. However, position can effect technique, so mess with it until it feels right.



Fingers

(Any Questions?)

Finger Numbers and Letters

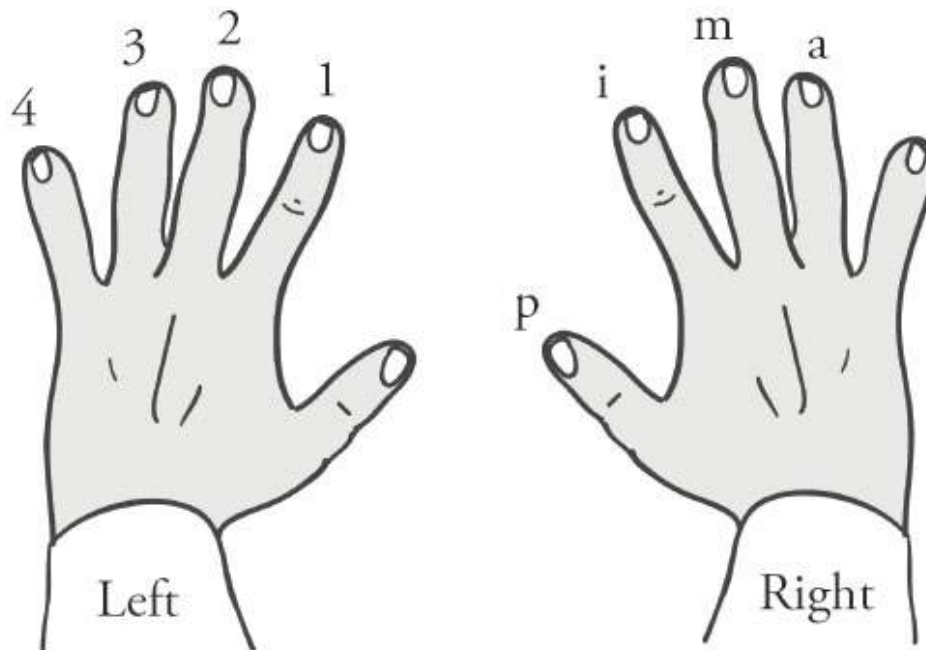

Plucking Hand
(The one by
the Pick-Ups)

"p" is your thumb (Pollex)
"i" is your pointer (Index)
"m" is your middle (Middle)
"a" is your ring finger (Annularis)

We will refer to the fingers often for the charts to come. Please refer back to this for reminders of which finger is which when necessary.

Playing

Okay, you're tuned up, plugged in, have figured out the knobs on your bass and amp by experimenting and reading instruction manuals right? Good.

We're going to start with the right hand. Leaving your thumb on the pick-up, use the i finger on your right hand to "pluck" the big fat string closest to your face. (The E String, or B string on 5 or 6 string basses) You don't want to pull "out" from the bass but pull up towards your chin. Once this motion becomes comfortable, add the m finger and switch between the two.



What a mess!! Right? The craziest sounds are coming out of your bass right now. You're only plucking one string but the whole thing is vibrating, the other strings are making sounds and "resonating" with the big E string you're plucking. Yup, this is where the left hand comes into play. With your left hand, lay them across all the strings between plucks to "mute" or "dampen" the strings. Repeat until you only hear the E string for each pluck.

Good. Now that you've got that down, using your right hand alternating from the i to the m fingers plucking the E twice, then the next string which is A then the next which D then the most skinny one closest to the ground which is the G string. Continue to work on that motion so your right hand gets used to moving up and down. Start from the top and go down, then start in the middle and go up one, then down two or whatever. Get the hint so far? You're moving up and down the strings plucking all while keeping it under control.

"This sucks. I want to learn to play like Victor Wooten. Can't I just start there? Fine, I'll settle for some Primus? What? 12 bar blues? Who cares about blues?" Every bass player that wants to be a bass player knows 12 bar blues and that's where many started. It's a 1-4-5 progression, real simple over 12 measures. Make sense? No? Exactly.



Learning Notes

open

Start Here →

E A D G

“Who cares about learning notes? This isn’t important. I don’t want to learn to read music, I just want to play.” Okay then, play something.....that was beautiful. Now, why learn where the notes are on your bass? This is the most basic form of communication for band members. Guitar players learn chords. This doesn’t mean they know how to read music either. “All right, we’re going to play C, F, G, four bars each and repeat.” What does this mean to you? Well, for some it’s 1-4-5, others it’s the notation and it’s 12 measures either way. This kind of verbiage and communication is so normal that if you don’t understand it you may appear as though you don’t know what you’re doing. (Honestly you don’t.)

On the right is a chart of the fretboard for a 4 string bass. The first five frets contain every note. We recommend memorizing the first five frets of notes so you can play the notes on command, then grow from there. Everything above the fifth fret is simply a duplication and perhaps higher pitched version of what’s in the first five.

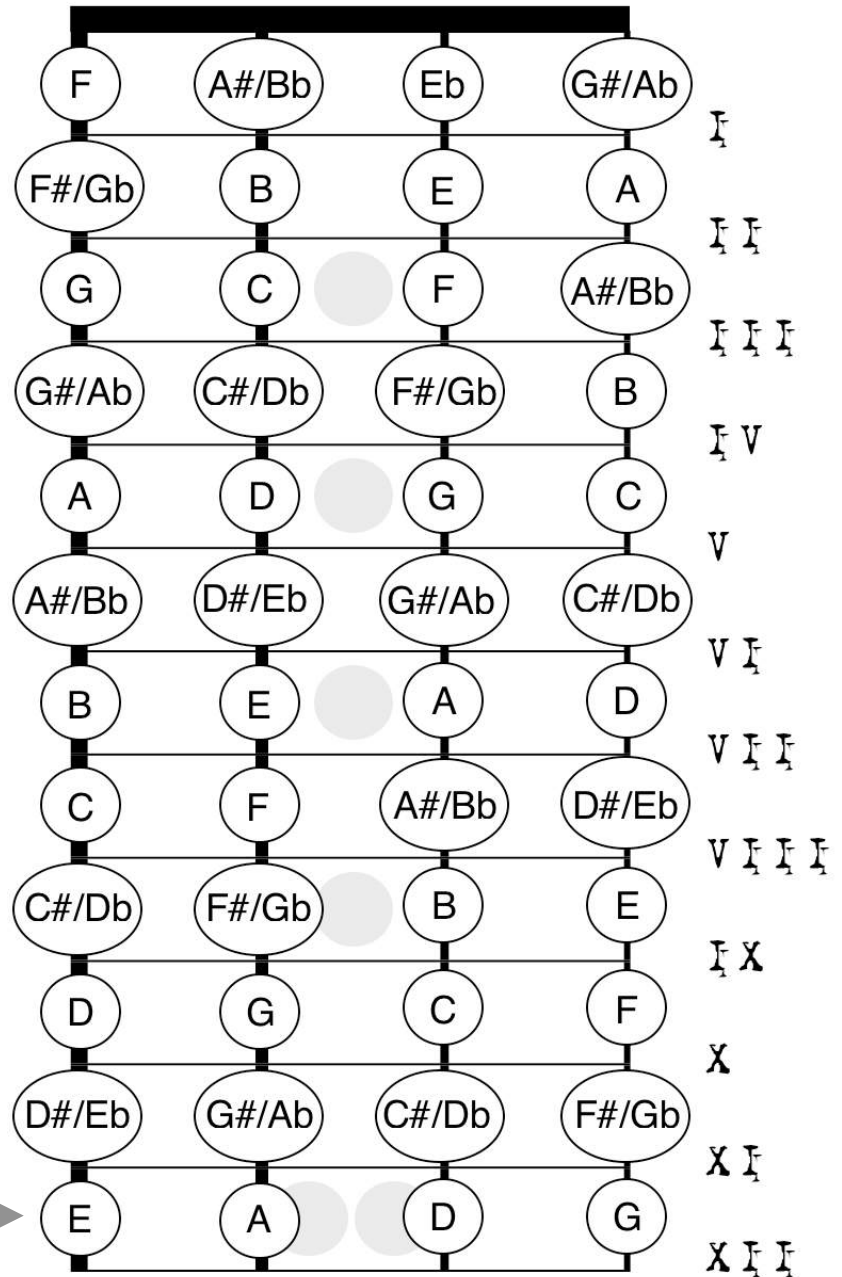

End Here →



Root is all you need to start. Playing one note at a time and one note only makes you a bass player. Playing in time and in rhythm makes you a good bass player. Being able to play additional notes and texture makes you a great bass player.



Scale Degree

Scales

Which Finger in Red
1-2-3

“Why learn scales? I just finished learning the notes and know root. I can play bass now.” Yes, you can in a garage band or to your favorite tunes on your iPod. Scales are the first step to knowing and understanding how to create bass lines, identify what another bass line is and how to duplicate it. As you follow the scales, you will always go up (low to high) then back down (high to low). You will only use three fingers for the patterns, 1, 2, and 3 and in that order going up and 3, 2 and 1 going down. Resist the temptation to use the 4th finger. It serves a purpose, but not here. Not yet.

M
a
j
o
r
h
a
r
m
o
n
i
c
i
o
r

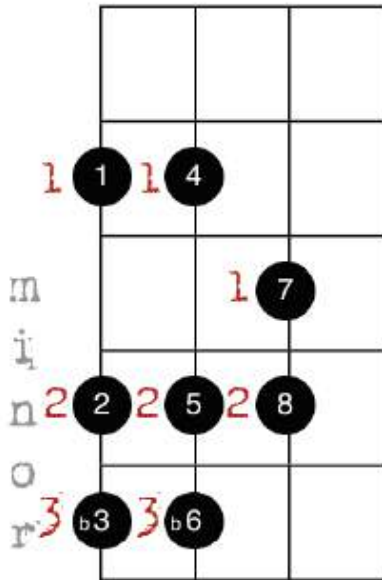
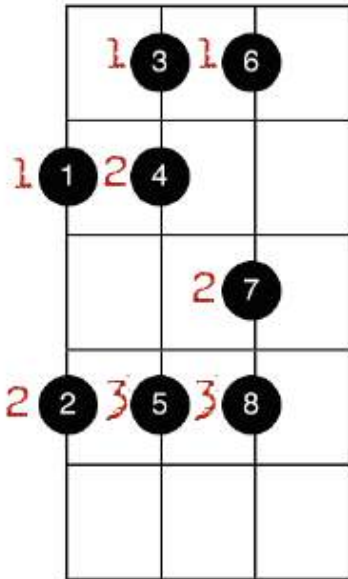

W
a
l
k
i
n
g
s
c
a
l
e

n
a
t
u
r
a
l
j
a
z
z

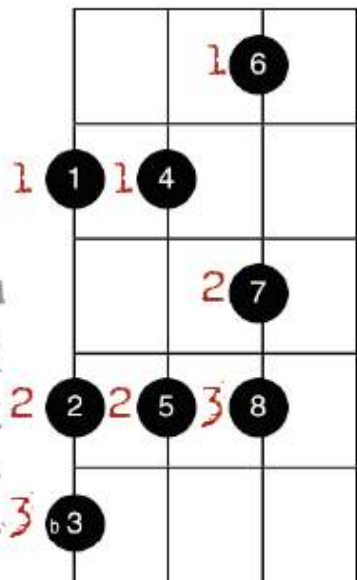
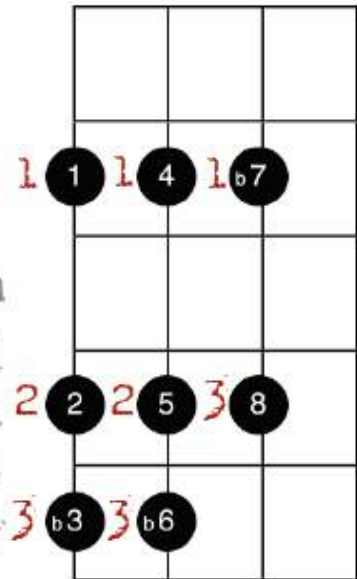

The numbers in the scale chart are called “Scale Degrees”. Start paying attention to these numbers and get familiar with going from one number to another. This is a very common form of communication within bands. If someone says 1-4-5 in major, you know where to go!!



Basic Theory

Okay, now you have the notes memorized, have some scales down, and have practiced the scale degrees right? You know how to start on the 5 then go to 1 then to 3. If you're in the key of C that would be what? G, C, E - right? GOOD JOB!! Moving forward. The following chart is a small collection of things you'll see on sheet music. Just as important are the words and what they mean when they are yelled out to you. "Play whole notes then eighth notes." This may make some sense now, or none at all, but review and memorize the details below.

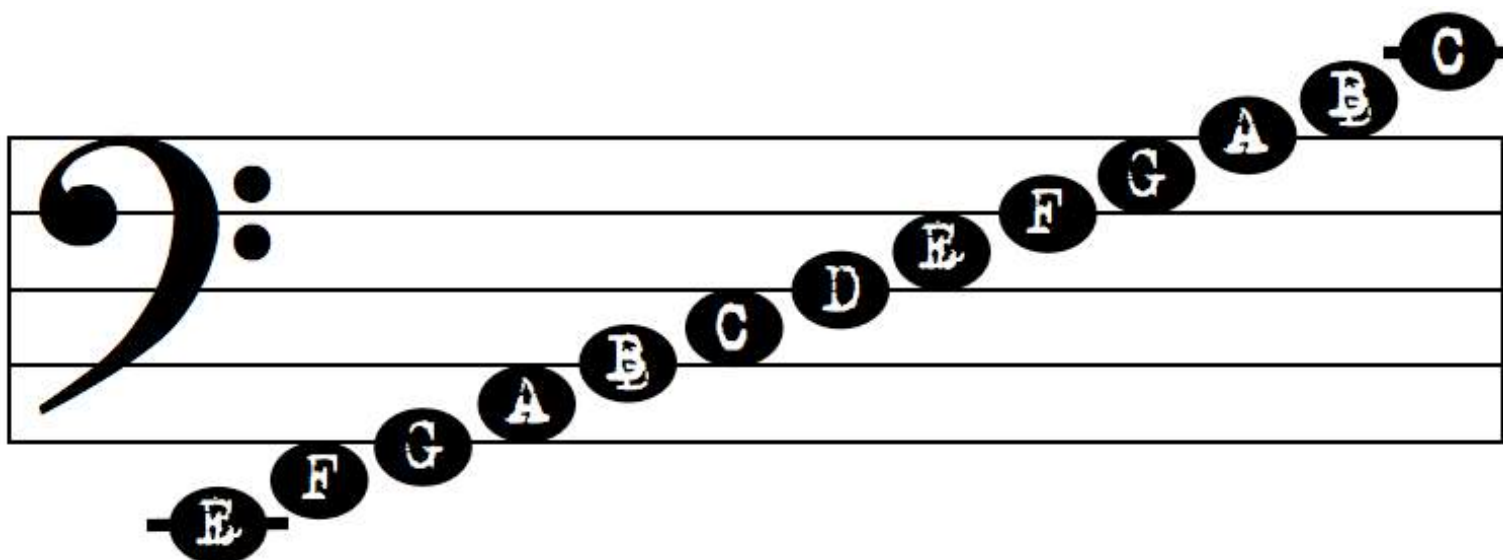

Name	Note	Rest	Length
whole	o		4 beats
half			2 beats
quarter			1 beat
eighth			1/2 beat
sixteenth			1/4 beat

Often times different ways of learning to play a song will still incorporate music theory terminology. Tablature, chords, private lessons, by ear, and so on. Understanding what these details are even if you don't have "sheet music" is important for communication and figuring things out.

Key Signatures

In the world of music, there are sharps and flats. What are they? If something is “Sharped” then it goes up one HALF step or ONE fret “higher” (toward the body of the bass). If something is flatted you move down one HALF step or ONE fret “lower” (toward the tuners, moving away from the body of the bass). One of the great tricks about bass guitar is when someone says play in the Key of E. All you need to know is the E Major Scale which you should if you know where E is on the fret board and then play the Major Scale finger patterns. Because you know the finger pattern for ALL MAJOR scales then you are correctly playing the 4 sharps in the Key of E correctly, which are F, C, G, D. Very cool huh? You’re a master!!!

S
H
O
R
T
C
U
T

F	G
B ^b	D
E ^b	A
A ^b	E
D ^b	B
G ^b	F [#]
C ^b	C [#]

When you see sheet music you can quickly find the key. If it's Flats go to the second to last Flat and that's the key. This is always true except for the key of F. If you only see one flat, it's F. Tough to remember. For sharps, raise the last Sharp a half step and that's the key. You'll have to learn which notes are on what space and what line which is covered back on the basic theory page, but you already know all the notes right? =)

Understanding key signatures is something that will come with practice and time. By knowing the patterns first and the notes of the fret board you can begin to figure out which key has so many sharps and flats. The chart above is a very powerful tool and important to know so you can correctly improvise and create bass-lines for songs. Also have a good understanding of what set of key signature rules you're dealing with when you choose to solo and adjust an existing bass line.



The Circle

Of fifths.....or fourths, depending which way you read. This goes hand in hand with the key signatures chart you just learned. You'll see that this circle goes in perfect order for fifths of fourths in accordance to the key signatures, and defines the order of sharps and flats, and why. This doesn't really do anything to help you play the bass in the near term, but is good knowledge to have. If you begin to chat about the circle of fifths you sound smart, impress those also jumping into theory, and it may actually help you down the road.

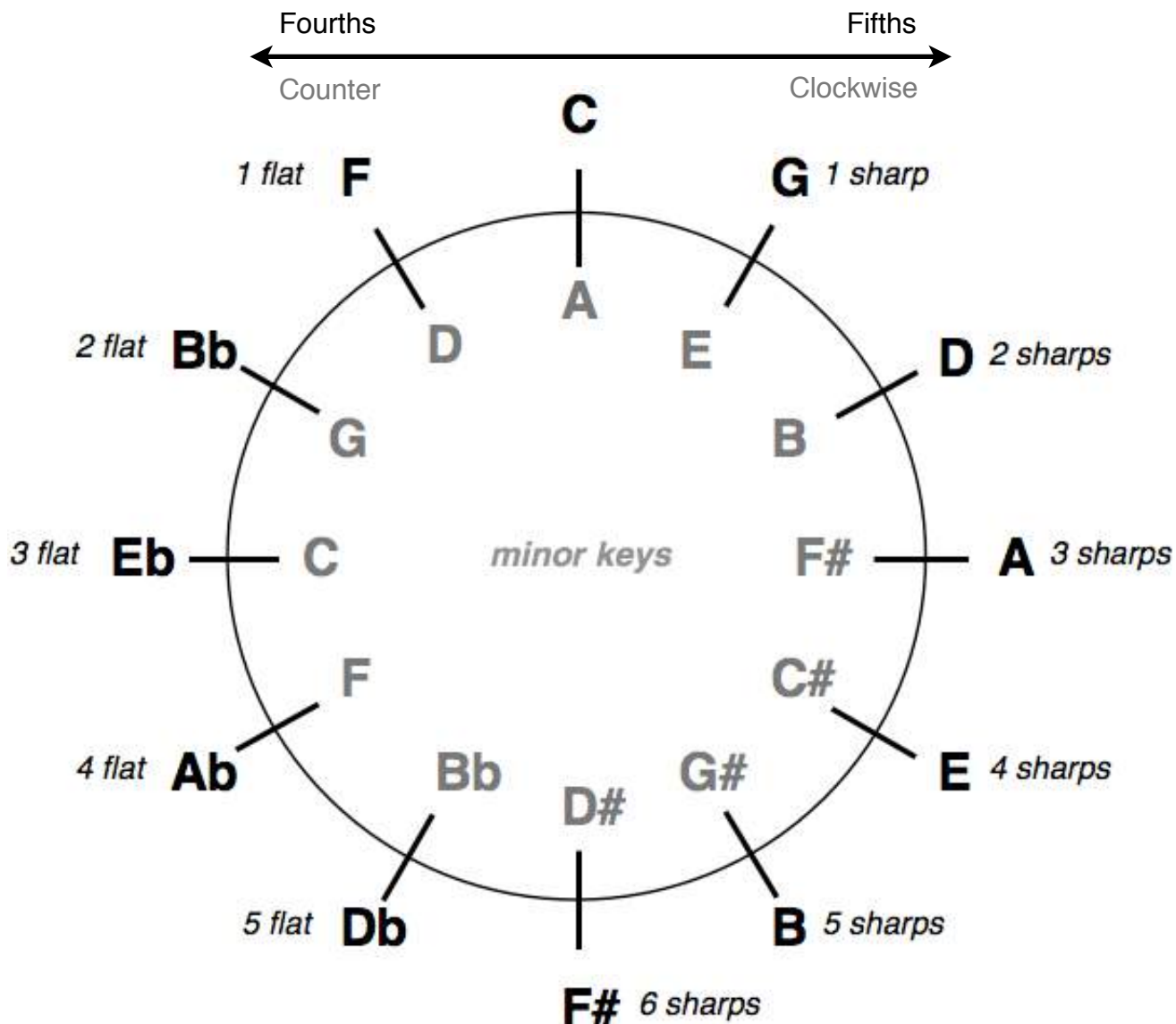

The Circle is one of the most popular charts to begin working with for music theory, and is considered by most music programs an element of basic musicianship. We agree. Learn this circle, understand how it arranges with key signatures, and how it only works in fourths and fifths to correlate with sharps and flats. It's very cool and an exciting element to music once it "clicks" in your mind.



C O U N T I N G

“Counting? Really?” Yes! I promise this isn’t an insult. You’d be surprised at how much brain matter is stimulated by counting and executing your fingers to be in sync.

BPM = Beats Per Minute

Lets start at 60 BPM. The magical thing about this is the question “how many seconds are in a minute?”. Yup, this works out great. So, look at an egg timer, and old watch or a metronome if you have one.

Playing one note per second in 4/4 time would be quarter notes. Two notes per second would be eighth notes, four per second would be sixteenth notes.

How to count these out loud?
Quarter notes are the best place to start. Always count 1-2-3-4. Now we will break it up. 1-2-3-4 = quarter notes counting. 1 and 2 and 3 and 4 and would be eighth notes. 1 E And A - 2 E And A - 3 E And A - 4 E And A would be 16th notes.

“You can’t hold no groove if you ain’t got no pocket.”
- JD Blair (A drummer for Vic)

1 2 3 4



1 and 2 and 3 and 4 and



1-E-AND-A 2-E-AND-A 3-E-AND-A 4-E-AND-A



You’re a bass player. You’re the glue remember? You’re holding everything together. Grooving with the drummer and/or percussion is essential. As a rhythm section player, you are helping to keep the rhythm. If you can recall every scale, every note, every piece of theory, but can’t play in time....you’ll have a hard time making the cut. Learning the charts above applies to all ways of playing. Knowing how these notes sound in regards to pace and quantity is important in any setting.

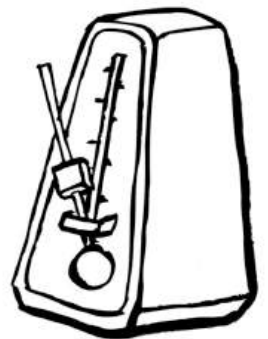

Learn the notes, learn the verbiage and be able to communicate to band members. When someone calls out “the verse is in eighth notes” you’ll know what’s going on!

Reading Music

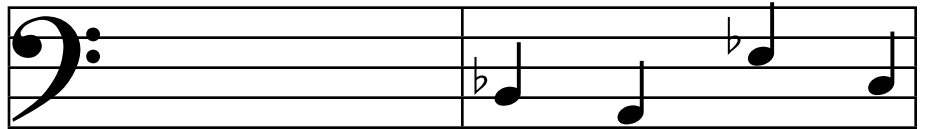
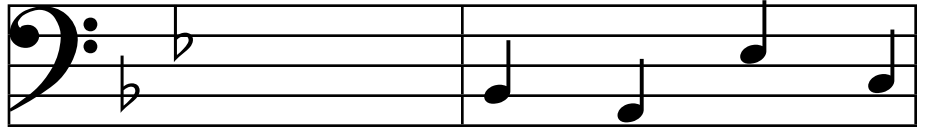

1 - 2 - 3 - 4 1 - 2 - 3 - 4

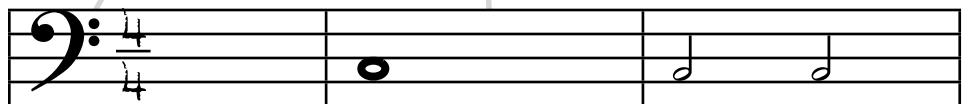

1 - 2 - 3 - 4 1 a - 2 a - 3 a - 4 a



1 - 2 1 - 2

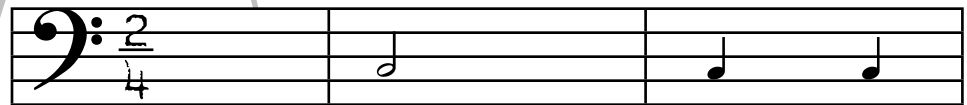

1 a 2 a 1/e/and/a 1/e/and/a



This is a very important skill and often times the last thing on your mind when you start playing. Now it's time to practice a little bit. Think of this as a new language. You'll get better at this with time and practice. Take it in small doses and work up from there.

By now you should know the key signatures. (This tells you what things are automatically sharp or flat in sheet music.) Accidentals are when something goes against the key signature and shows up in the music to make that specific note sharp or flat, just that one time.

Time signature tells you how many beats are in a measure. 4/4 is the most common which we've learned from the music charts has 4 beats to a measure. Like 1 whole note, 2 half notes, 4 quarter notes, 8 eighth notes and any combination of them. As the time signature changes you know how many beats are in a measure. 2/4 would have 2 beats like 1 half note, 2 quarter notes and so on. We'll get into odd-meter time signatures later.

Learning the notes is difficult for some. Learning the time is difficult for some. Use the exercise above and clap on the red. The sixteenth notes are 4 claps per beat hence forth 1-e-and-a. Practice makes perfect and with time and effort this will become effortless. Make sure to practice this on your bass too.



By the Numbers

More often than not, bass players are only told the chord progression to a song. Handed a document with the lyrics and the chords above the words when it's supposed to change. It's up to you to either learn the original bass line by listening to the song or make one up. This particular circumstance, as often as it happens, seems to be a place that discourages many bass players. Take a deep breath, don't worry. You'll get this figured out real easily. The best part about this is you have creative freedom to change a "stock" bass line to your own, throw in your own style and tasty licks as applicable.

key of C

C	G	A	G
Twinkle, twinkle little star.			
F	E	D	C
How I wonder what you are.			
G	F	E	D
Up above the world so high,			
G	F	E	D
Like a diamond in the sky.			
C	G	A	G
Twinkle, twinkle little star.			
F	E	D	C
How I wonder what you are.			

Now, because you've heard this song before, you have an idea of how it goes, how fast it is, and what not. When reading chords like this you can mix it up. Play the root on different octaves and add a cool sound often times called "texturing". This is your job to either hold it down or spice it up. Have fun! Now, you know how to play it in the key of C. What if someone says, let's bring it down a half step. Uh oh?!?

What if you need to transpose this chord progression to numbers?

Know your scales! If not, go back in the book and grab them. We know that this is in the key of C Major. C is the number 1 right? That makes D number 2 and so on. It looks like this.

C-1 D-2 E-3 F-4 G-5 A-6 B-7 C-8

1	5	6	5
Twinkle, twinkle little star.			
4	3	2	1
How I wonder what you are.			
5	4	3	2
Up above the world so high,			
5	4	3	2
Like a diamond in the sky.			
1	5	6	5
Twinkle, twinkle little star.			
4	3	2	1
How I wonder what you are.			

Know your scale patterns and the numbers. If you have the numbers prepared for a song and the singer says "my voice is tired today, let's bring it down a half-step, you know the numbers. Learn your scales and know where the notes are on the fret board. You are a bass master!!! Sometimes, you're only given numbers.

Modes

This is the last entry for basic musicianship within the music theory category. If you've made it to this point and understand everything else previously. You're ahead of most. Modes are the variations that happen within a key signature. Modes pre-date major/minor tonalities. What we call Major and Minor in today's music CAME from modes. For example. When looking at the chart, you will see that Ionian is the same as the Major Scale pattern and Natural Minor is the same as Aeolian. Pretty cool, huh!?! You already know 2 modes!!! Learn the rest. The numbers play a role too. Let's say you're playing in C Major and the chord progression has an E in there. When you get to the E you could play the Phrygian pattern because E is the third scale degree of C Major. (*not all notes work all the time, we'll get to that*) If you are ever stuck trying to think of a cool bass line and can't, it's probably because you don't know your modes. Come back to this chart and learn up again, and you can create some of the coolest stuff out there. Study up!!

relative to major scale

- 1- Ionian~ same as major scale
- 2- Dorian~ flattened 3rd and 7th
- 3- Phrygian~ flattened 2nd, 3rd, 6th and 7th
- 4- Lydian~ sharpened 4th
- 5- Mixolydian~ flattened 7th
- 6- Aeolian~ flattened 3rd, 6th and 7th
- 7- Locrian~ flattened 2nd, 3rd, 5th, 6th and 7th

Ionian

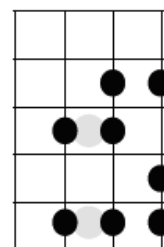

TIP!

Modes and Music Theory often times require multiple pots of coffee and philosophical contemplation prior to application for appropriate musical and academic use.



Dorian

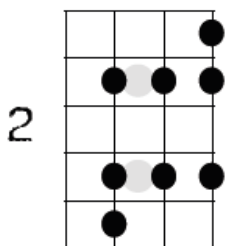

Phrygian

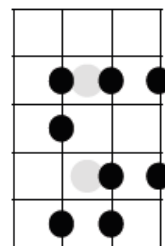

Lydian

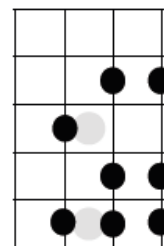

Mixolydian

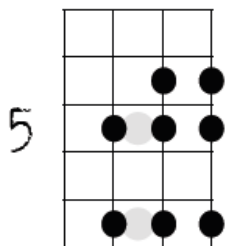

Aeolian

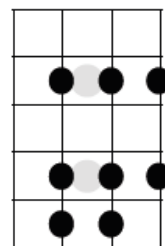

Locrian

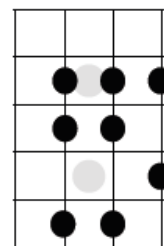

Don't overlook Modes. If you skip this, we assure you you will be back. Especially when you're trying to understand what a bass player is doing in a song and what you can do to enhance one.

Tone and EQ

95% of this sound is going to be determined by your equipment. Even beginner equipment is extremely versatile so don't be discouraged if you're on the cheap. (this is not a conversation about the plucking hand technique sound. ie- slapping, picking, walking, tapping, attack) Now, not all settings are created equal. Over time you will collect specific basses and specific amps to meet your sound desires. Is there one that's good all around? The answer could be yes, depending on how picky you are and If you're specific then.....no. You'll end up with tons of gear.



boring stereo
manual stuff

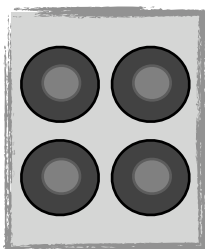

So now that we know that gear makes the biggest difference here, let's talk about the role the bass plays in sound. You're holding the darn thing right? You can change the sound in the middle of a song. If you're coming into a mellow bridge and have a tasty lick to add up high, then drop the lows a bit and boost the mids and highs for just a moment, then readjust for closing it out with the deep driving tone. This applies to almost everything. The greatest bass players are most difficult to duplicate not only by playing technique, but tone adjustments on the fly from high, mid, low, and on some basses that are active, a pan from front to rear pickups. Mess with it and get used to adjusting tone while you play to enhance the music.

"Set it and leave it" is one philosophy. Can you use this to change tone on the fly like the bass? For some players, sure. Most times, an amp is set up for the venue you're playing. You may have to move more air so boosting the lows comes in, or bringing it back off for smaller places. Perhaps you're too "bright" or high pitched so you taper it off for the setting. Depending on the player you'll get this set up for your playing style for the venue and use the bass EQ to really dial in tone. This is a preference and there are many opinions. Your gear will be a determining factor here too. If you have an awesome amp and a limited bass, you may use the amp more for changes.

In time you may want:
Chorus
Reverb
Delay
Mute
Envelope
Overdrive
Flanger
Loop
and the list goes on and on. These are all things you should use later if you want to enhance sound, not to cover up lacking technique.

Steps

1- practice 2- Have fun 3- repeat 1-2

Tone and EQ are very important. Your sound should be intended, on purpose, manageable and versatile. With even the most beginner type of gear your range of tone is HUGE!! Learn your gear, get as close as you can to duplicating sounds and different styles of music to know what you need to do to replicate those sounds you like. New and better gear always helps, but can't be an excuse.



Other Styles

The bass guitar isn't just for holding down the low end of a tune. There are many ways to spice up your sound and diversity of playing, separating you from the rest. There are substantial resources available online, private lessons, DVDs, and much more for learning and applying these different styles. Getting better, enhancing your skills and becoming a better bass player never ends. Even the most prominent names in bass express a desire to enhance their skills and get better. Don't worry, you'll always have your mark in the bass world, regardless of level of success or fame.

Slap!

This is a technique of literally slapping the strings with your right hand (thumb) striking them against the fret board to get an aggressive and defined sound. You may already know how this works and how to do it. Have fun, keep learning and find the right application for slap. Slap styles differ and you can take this as far as you want to go.

Tapping!

This is a beautiful and melodic sound found on the bass where you "tap" the fretboard on specific notes to form chords or play individual notes. Often times this is played in the higher range for sound and clarity. This requires deep knowledge of chords and theory to construct great sounding lines.

Harmonics!

This is the process of producing sub tones from strings that don't align with the fret you're doing harmonics on. It is essentially a "reverse vibration" and the pickups amplify an angelic and gorgeous guitar pitch tone.

With these styles and different techniques and tricks, the combinations are limitless. That's where even more magic happens. Being able to apply these different styles in a song when and where appropriate will take your playing to the next level.

the end

Never give up. Never stop having fun. Take pauses in playing as needed, but come back to the bass. The low end needs you.



MATTER

w w w . b a s s m a t t e r . c o m

Direct to Parent

SCALE MATTER CHART

M
a
j
o
r
t
r
i
a
d
i
a
n
c
h
a
r
a
c
t
e
r
i
s
t
i
c

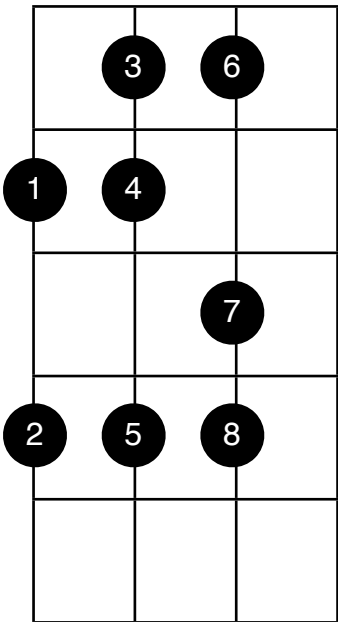

s
t
a
n
d
a
r
d

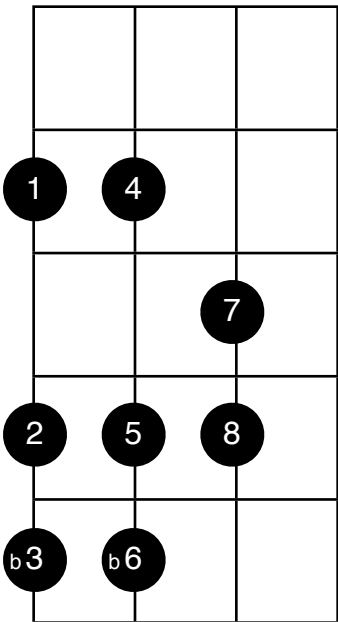

n
a
t
u
r
a
l
m
i
n
o
r
z
e
r

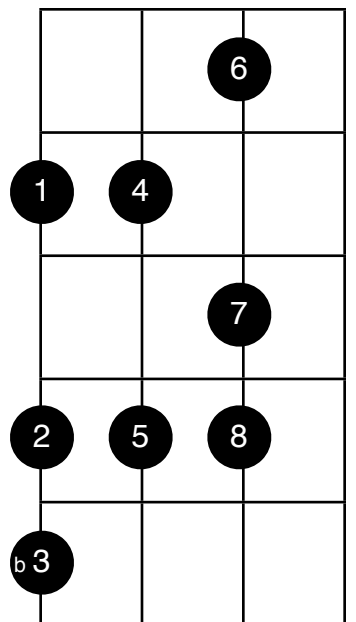
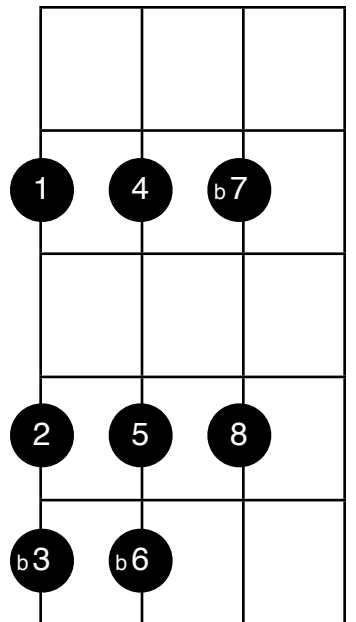

BASS MATTER

open
E A D G

12 fret board

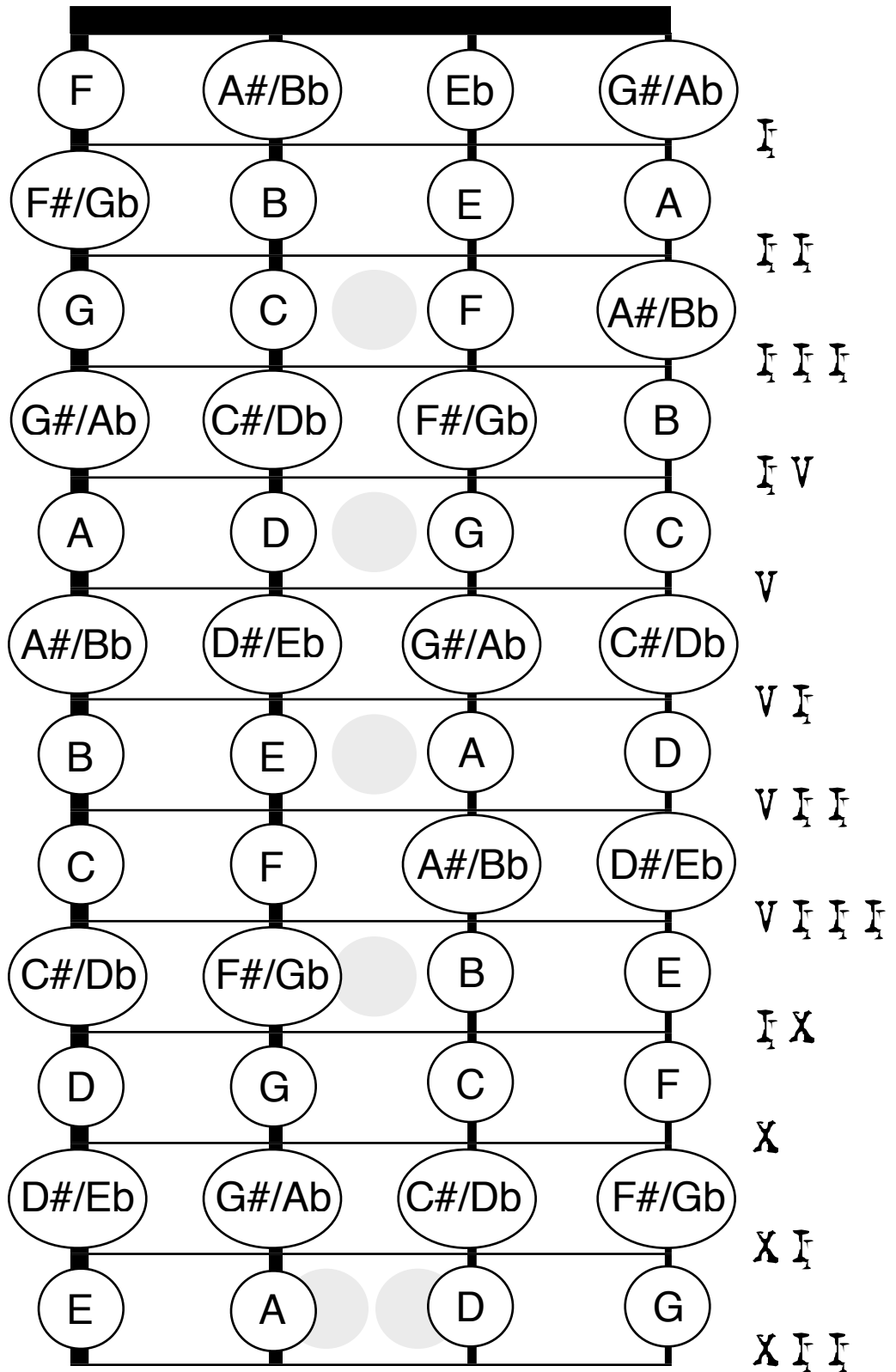

key

sig

MATTER

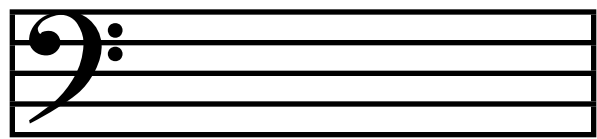

C

F

Bb

Eb

Ab

Db

Gb

Cb

G

D

A

E

B

F#

C#

basic theory

MATTER

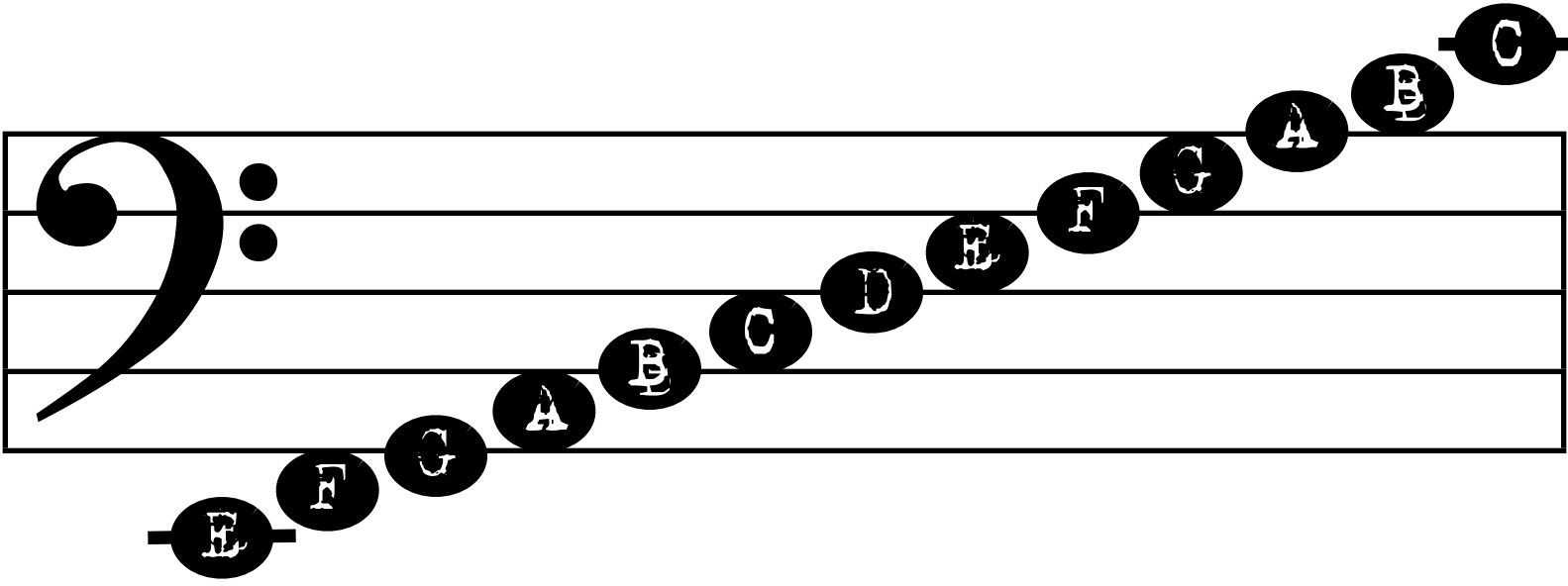

Name	Note	Rest	Length
whole			4 beats
half			2 beats
quarter			1 beat
eighth			1/2 beat
sixteenth			1/4 beat

BASS MATTER

fifths
 &
 fourths

← Fourths Counter → Fifths Clockwise →

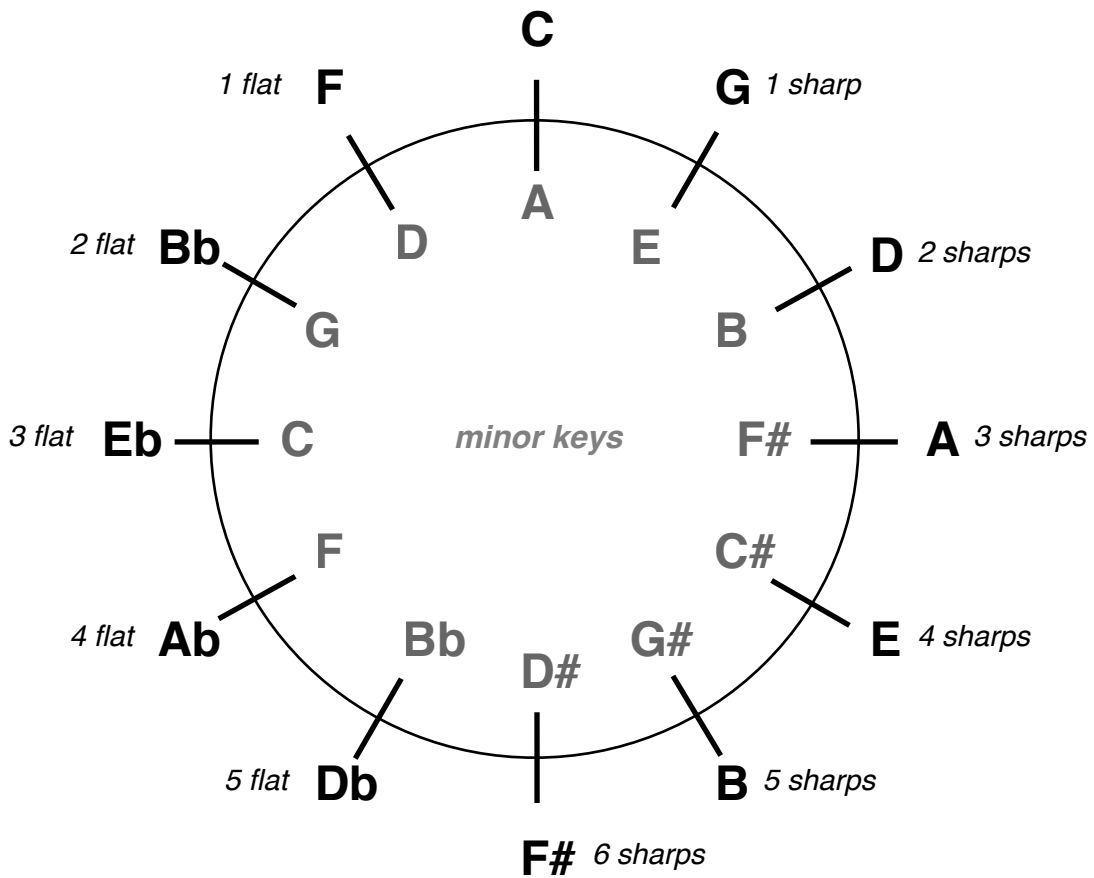

MODE

MATTER

CHART

relative to major scale

- 1- Ionian~ same as major scale
- 2- Dorian~ flattened 3rd and 7th
- 3- Phrygian~ flattened 2nd, 3rd, 6th and 7th
- 4- Lydian~ sharpened 4th
- 5- Mixolydian~ flattened 7th
- 6- Aeolian~ flattened 3rd, 6th and 7th
- 7- Locrian~ flattened 2nd, 3rd, 5th, 6th and 7th

Ionian

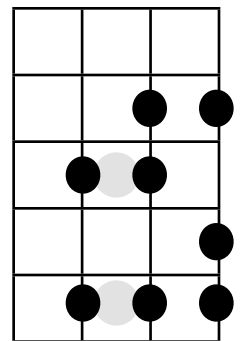

Dorian

2

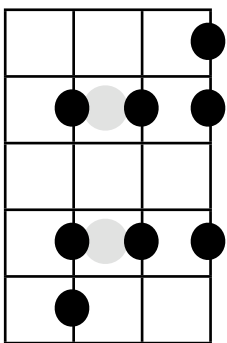

Phrygian

3

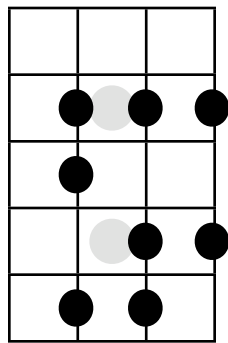

Lydian

4

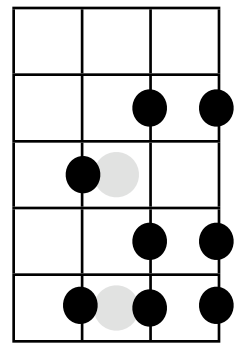

Mixolydian

5

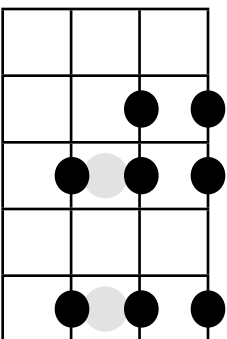

Aeolian

6

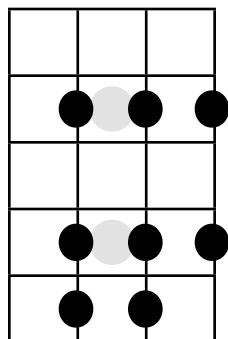

Locrian

7

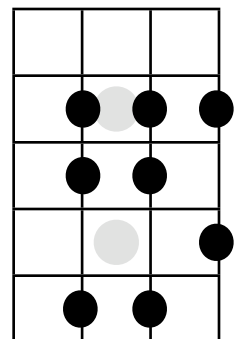

staff paper

