

Module-IV

Automotive Emission Control Systems

- ❖ Automotive emission controls,
- ❖ Controlling crankcase emissions,
- ❖ Controlling evaporative emissions,
- ❖ Cleaning the exhaust gas,
- ❖ Controlling the air-fuel mixture,
- ❖ Controlling the combustion process,
- ❖ Exhaust gas recirculation,
- ❖ Treating the exhaust gas,
- ❖ Catalytic converter,
- ❖ Emission standards- Euro I, II, III and IV norms,
- ❖ Bharat Stage II, III norms.

❖ **Automotive emission controls:**

The purpose of emission control is to reduce amount of pollutants and environmentally damaging substances released by the vehicles. If not controlled, the automobile can emit pollutants from fuel tank, carburetor crank case and exhaust system in the atmosphere. The fuel tank and the- carburetor emit gasoline vapors, crank case releases partly burned air-fuel mixture blown off by piston rings and pollutants from exhaust system consists of partly burned hydrocarbons, carbon monoxide, nitrogen oxides and sulphur oxide. The smoke may be formed due to incomplete burning of fuel [Smoke: particles of unburned fuel and soot called particulates, mixed with air]. It took many years for the public and the automotive industry to address the problem of these pollutants.

It is estimated that in USA alone 200 million tons of manmade pollutants adds to the air. Therefore-these pollutants, if not controlled, adversely affect our health. Automobile manufacturers have been working towards reduction of auto motive air pollutants when auto emissions were found to be part of the cause of mog. The emission of pollutants can be decreased by improving combustion efficiency which in turn needs redesigning of fuel tank, carburetor combustion chamber, cooling system run on and exhaust system. The other way of controlling atmospheric pollution is, destroy the pollutants after they have been formed.

The emission of pollutants in Auto motives can be reduced by

- Closed crank case ventilation
- Fuel tank and carburetor ventilation
- Redesigning the engine
 - (i) Combustion chamber,
 - (ii) Cooling system,
 - (iii) Fuel supply system
 - (iv) Ignition system

❖ **Controlling crankcase emissions:**

Closed Crank Case Ventilation [Controlling Crank Case Emissions]:

This system consists of two types (i) Positive crank case ventilation and (ii) Fixed orifice system.

Positive Crank Case Ventilation Systems [PCV Systems]

When engine is running, some unburned fuel and combustion products leak past the piston rings and move into the crank case. This leakage is called blow by. This blow by must be removed from the engine-Crankcase, before it condenses and reacts with oil to form sludge, which may corrodes and accelerates wear of pistons, piston rings, valves, bearings, etc. Sludge can also clog oil lines and starve the lubricating system. As the engine oil circulates, it also carries blow by and some unburned fuel particles which are formed due to incomplete combustion of air-fuel mixture in to the crank case.

If not removed, this dilutes the engine's oil and hence the oil does not lubricate the engine properly resulting in excessive wear. Filtered air from the carburetor air clearer must be circulated through the crank case to remove blow by gases and gasoline vapors from the crank case. To prevent atmospheric pollution modern engines have a closed system called PCV system. The flow by gases and gasoline vapors are picked up by filtered air to the engine inlet manifold through a special PCV valve and from there enters into engine combustion chamber with fresh charge and are burnt there.

The PCV valve consists of a spring loaded tapered valve. The valve is in closed position under the action of crank case pressure and manifold vacuum where as the spring pressure keeps the valve open there by regulate the flow of blow by gases. During idle or deceleration (low speed) amount of blow by gas is less due to lesser engine load and a small

PCV valve opening is needed to move blow by gases out of crank case. The high intake manifold vacuum moves the tapered valve against spring pressure, thus provides small opening in the valve for the flow of blow by gases. During part throttling (or normal speed), engine load is higher than at Idle, blow by increases and manifold vacuum decreases.

The spring moves the tapered valve to increase the opening. The larger opening allows the entire blow by gases to enter in to the intake manifold. At high speeds or when the engine is operating under heavy load, the throttle valve opens widely and decreases intake manifold vacuum. The spring moves the tapered valve further down ward to provide a larger opening through the valve. The amount of blow by gases is more, when engine load is high, hence larger PCV valve opening is essential to allow these gases to flow through the valve in to the intake manifold.

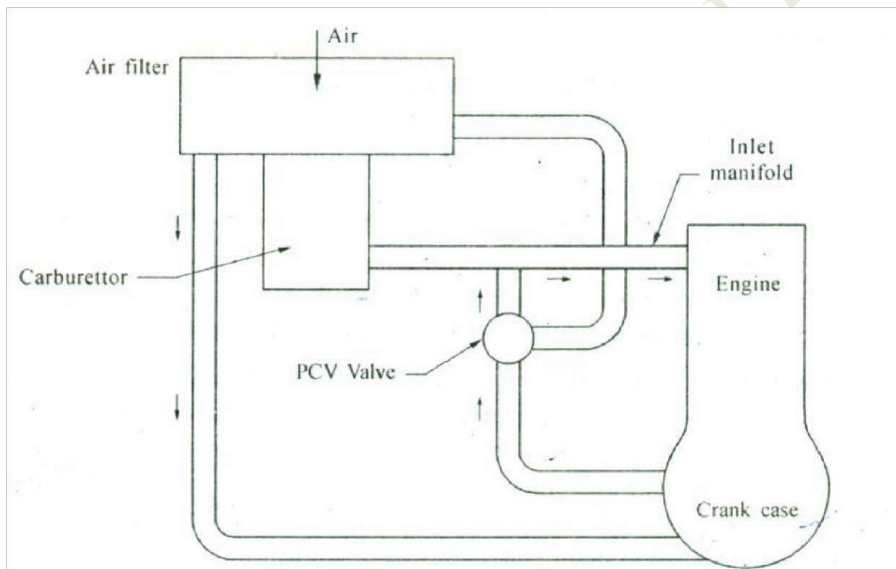

Fig: - Schematic diagram of positive crank case ventilation

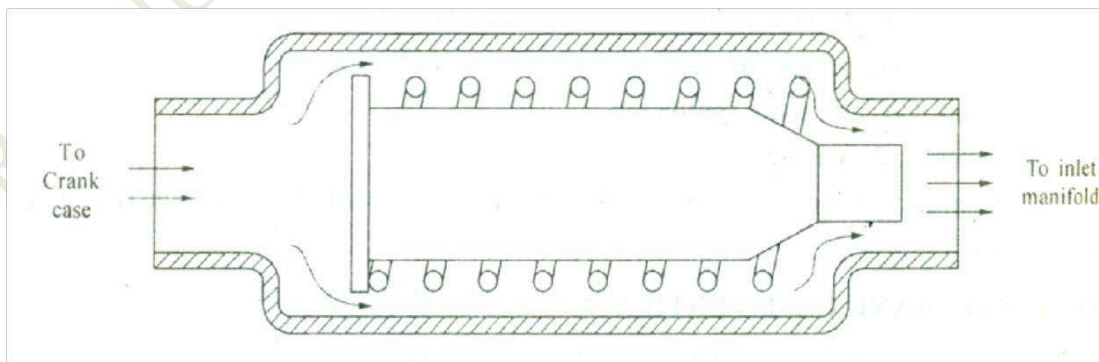

Fig:-PCV Valve

Fixed orifice tube PCV System

Some engines are not fitted with PCV valve. The blow by gases is routed in to the intake manifold through a fixed orifice tube. This system works similar to PCV valve, except that the system is regulated only by the vacuum on the orifice. The amount of blow by gas, flows in to the intake manifold is limited by the size of the orifice.

❖ **Controlling evaporative emissions:** [Evaporative emission control systems]:

The fuel evaporative control system capture the gasoline vapours from the fuel tank and carburettor float bowl and prevents them from escaping in to the atmosphere. This system is called by various names such as active emission control (EEC), evaporative control systems (ECS), cycle vapour recovery and vapour saver (recovery) system (VVS / NRS): Since fuel injection systems do not have a float bowl, the ECS controls escape of fuel vapours from the fuel tank only.

Vapour recovery system in carburetted engines

If the vehicle is not fitted with VRS, the gasoline vapours from the fuel tank and carburettor escape in to the atmosphere by evaporation or breathing. The fuel tank breathes with change in temperature. As temperature increases, the air inside the tank expands and thus forced out through either the filter cap vent or the tank vent tube. This air carries gasoline vapour. When the temperature decreases, the air inside contracts and hence outside air enters in to the tank. This breathing of tank causes loss of gasoline vapour and discharges it into atmosphere.

The gasoline vapour is also escapes from the carburettor float bowl by evaporation. When the engine is running, the cater float bowl is full. When the engine stops, the heat of the engine evaporates some or all of the gasoline stored in the float bowl. The vapour recovery system reduces atmospheric pollution by preventing gasoline vapour to escape in to atmosphere. All modern cars are fitted with VRS.

The layout of vapour recovery system is as shown in figure. The fuel tank and carburettor are vented to a carbon or charcoal canister instead of vented in to atmosphere. When the engine stops, fuel vapours run the tank and float bowl enters into a carbon or charcoal canister. In the canister, the activated charcoal adsorbs the vapour and stores it [absorb means - vapours are trapped by sticking to the outside of the charcoal particles]. When the engine starts, the gasoline vapour in the canister is picked up by fresh air flowing through it. Then the air flows into engine intake manifold and becomes part of air fuel mixture entering the engine cylinders. This action of flow of fresh air to pickup the trapped gasoline vapour from the canister is called "Purging". The

system also consists of a vapour liquid separator on the fuel tank. This chamber separates vapour from the liquid gasoline which in turn returned to the tank. A mechanically operated vent valve or an electrically operated solenoid valve may be used to control flow of vapours from the fuel tank. The mechanical valves operated by the throttle linkage. During idling, it is open and causes the vapour to flow from float chamber to the canister. The opening of throttle closes the vent valve; likewise, the electrical vent valve is open when ignition is off. When the ignition is on, the vent valve is closed by the energisation of solenoid.

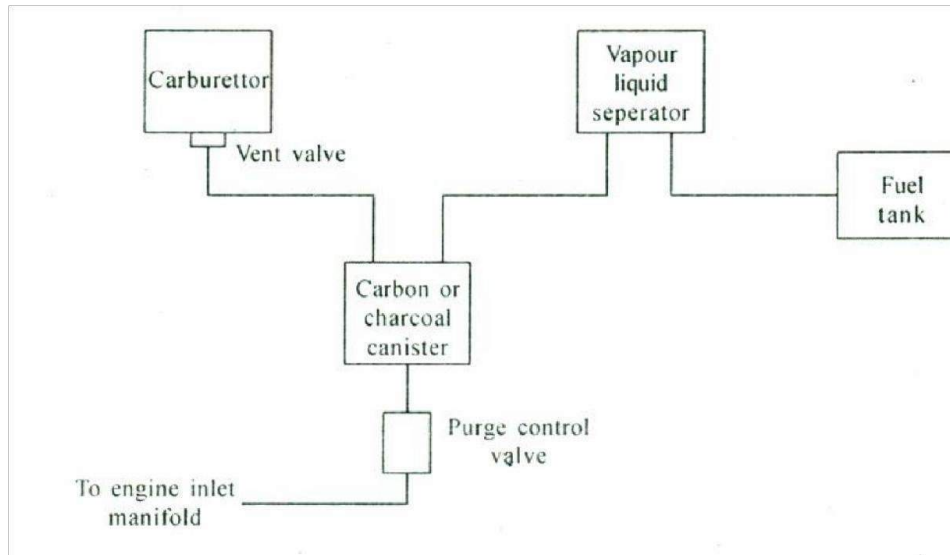

Fig: - Schematic diagram of a vapour recovery system

Evaporative Control System (ECS) for fuel injected engines

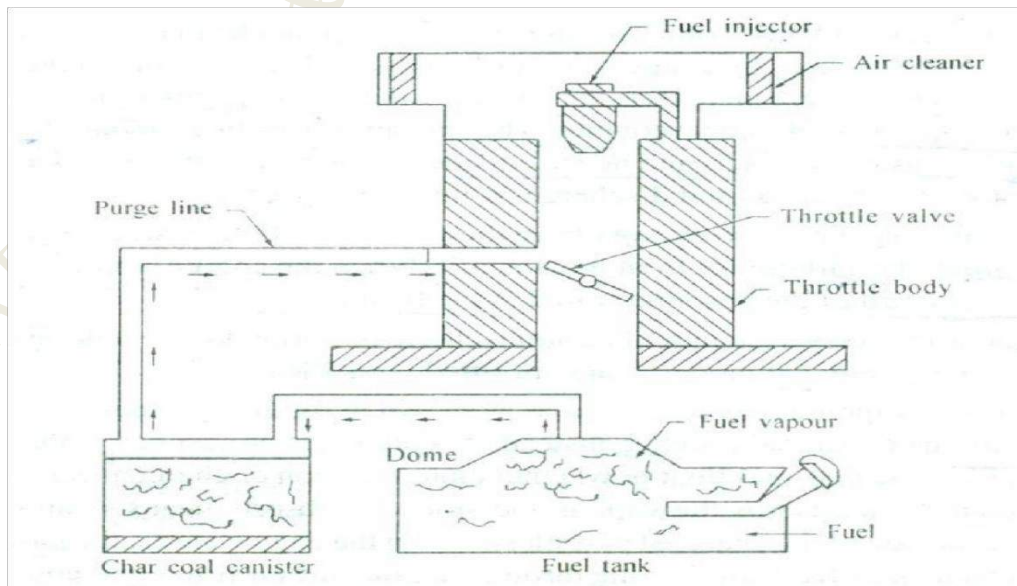

Fig:- ECS for an engine with throttle body injection

The fuel injection system do not have float bowl, therefore ECS controls escape of fuel vapour from the fuel tank only. The canister is connected to hose from the fuel tank. The purge line from the canister is connected to the throttle body. An electric purge control solenoid may be used instead of vacuum operated purge valve. The solenoid valve may be fitted on the canister or in the purge line and normally open.

❖ **Cleaning the exhaust gas:**

The Automotive engines burns liquid fuel gasoline which is a hydrocarbon (HC), made up of hydrogen (H) and carbon (C). During complete combustion, gasoline produces water vapour and carbon dioxide which are harmless to atmosphere. However, in automotive engines, combustions are never complete. Some unburned hydrocarbon (gasoline) and carbon monoxide (formed due to in complete combustion of gasoline) and nitrogen oxide (formed due to high combustion temperature) will remain in the exhaust gas. Therefore combustion can be represented by $HC + N + O_2 \rightarrow CO_2 + H_2O + CO + NO_x + HC$

The carbon monoxide, HC and NO_x causes air pollution.

In automotives, sources air pollution are engine crank case, air cleaner or carburettor, fuel tank and tail pipe. The pollutants from each of these sources are controlled by emission control devices like crank case emission control systems, evaporative emission control systems, exhaust emission control system.

The methods used to reduce amount of pollutants in the exhaust gas are

1. Controlling gasoline quality
2. Controlling the air-fuel mixture
3. Controlling the combustion process
4. Treating the exhaust gas

Controlling gasoline quality

The characteristics of the gasoline can be improved by adding some additives during refining. Good quality gasoline posses following characteristics,

1. *Proper volatility*: This property indicates how easily the gasoline is converted into vapour.
2. *Resistance* to detonation.
3. *Oxidation inhibitors*: Avoids gumming tendency in the fuel system.

4. *Anti-rust and Anti-freezers*: To prevent rusting of components in fuel system & avoiding blocking of fuels lines.
5. *Detergents*: To clean carburettor and fuel injector.
6. *Dyes* - gives colour for identification.

Controlling the air-fuel mixture

Controlling the air-fuel mixture is nothing but

- i) Modifying the fuel system or carburettor to deliver a leaner air-fuel mixture
- ii) Faster warm up and quicker choke action.

The ideal air-fuel ratio [14.7: 1] required for complete combustion of fuel is called air-fuel ratio. If this air-fuel ratio is lower, say 14: 1, it means, there is excess fuel for available oxygen. If it is higher, say 16: 1, it means there is an excess of oxygen. As engines operates mostly at part throttle, the ECM maintain air-fuel ratio at stoichiometric ratio during part throttling. The engine performance is better at ideal air-fuel mixture (14.7: 1) and produces minimum exhaust the amount of oxygen in the exhaust gas is indicated oxygen sensor which sends signals to ECM. This shows leanness or richness of air-fuel mixture. Then the ECM adjusts the richness of the mixture.

Faster engine warm up and quicker choke open increases exhaust emissions during warm-up. If the carburettor [fuel supply system] supplies cold air-fuel mixture, only a part of fuel will vaporize. This makes the air-fuel mixture lean and extra rich mixture is required. Therefore, when the engine is cold, a thermostatically controlled air cleaner is used to supply heated air quickly to the carburettor. During cold running, air entering carburettor is heated up by thermostatic air cleaner, which allows engine to run on a leaner air-fuel mixture during warm up.

The thermostatic air cleaner consists of a temperature sensing spring which senses temperature of air entering the air cleaner. The air bleeds when air is cold and this applies intake manifold vacuum to the vacuum motor. The diaphragm and hence to control am per assembly moves up due to atmospheric pressure and thus blocks the snorkel tube. This allows all the air to enter through the hot air pipe which is laid near to the exhaust manifold. When the engine starts, the exhaust manifold heats up quickly, and hence allows heated air to enter into the air cleaner. This heated air helps to vaporize the fuel delivered by carburettor or fuel injectors, which in turn

improves cold engine performance.

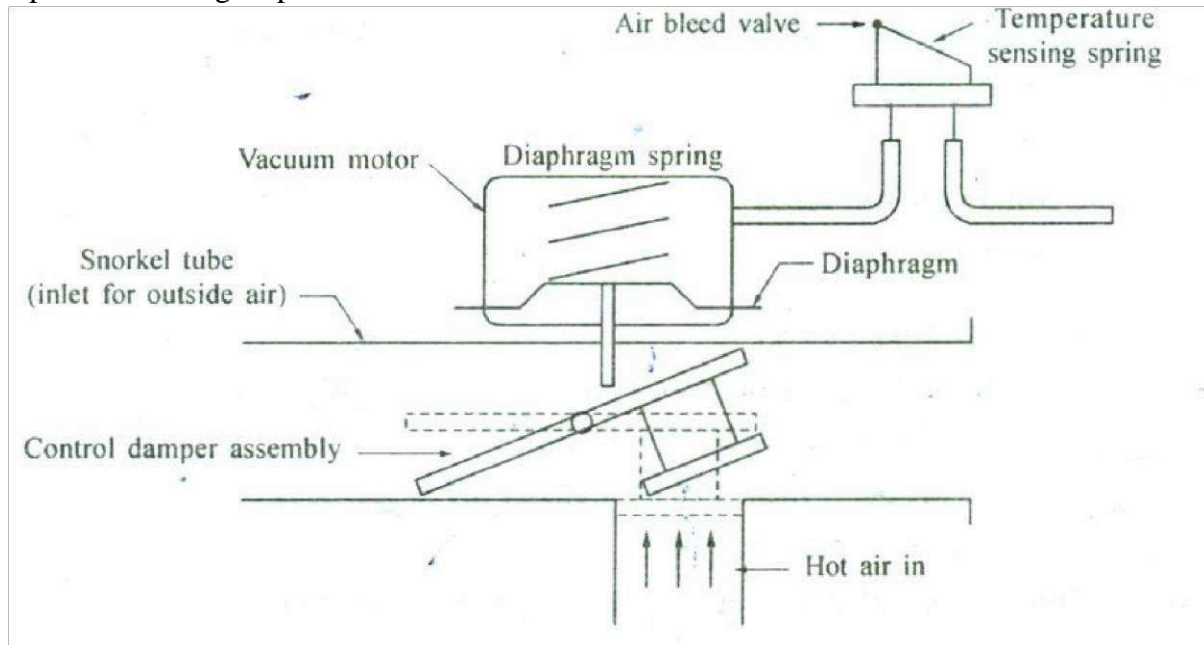

Fig: - Thermostatic air cleaner

Controlling combustion process

Combustion in the engine cylinders is a complicated phenomenon. The factors which affect the combustion process are:

The air-fuel mixture near to the cool cylinder wall, cylinder head, top piston ring and piston head do not burn. The metal surfaces cool these layers below the combustion point. Therefore, during exhaust stroke, this unburned mixture (fuel) is swept out of the cylinder. This adds polluting HC to the atmosphere. This problem is rectified by introducing stratified charge in the engine cylinder or by fuel injection method. The other method is providing lesser surface area around the combustion chamber. A hemispherical combustion chamber has less surface area and releases less unburned HC in to the exhaust.

The combustion temperature results in better combustion in fuel and reduces unburned HC and CO emissions in the exhaust. But this results in formation of more nitrogen oxide (NO) and adds pollutants to the atmosphere.

During part throttling, vacuum advance provided in the ignition distributor gives the air fuel mixture a longer time to burn. Under certain operating conditions, this also results in formation of more Nitrogen Oxide. The devices used to prevent vacuum advance are;

(a) Transmission Controlled Spark TCS or Transmission Regulated Spark (TRS) system: It

delays vacuum advance when the transmission is in neutral reverse and forward gears.

(b) Spark Delay Valve (SDV) It prevents vacuum advance during certain conditions of vehicle acceleration.

The carbon deposits present in the combustion chamber absorb air-fuel mixture and during exhaust releases air-fuel mixture. The HC in the exhaust gas, add pollutants to the atmosphere.

Exhaust gas recirculation

The higher combustion temperature (more than 1927°C) results in the formation of more Nitrogen Oxides. The exhaust gas recirculation of EGR system is used to lower the combustion temperature and hence to reduce NO emissions in the exhaust gas. A small metered quantity (6 to 13%) of inert exhaust gas is sent back in to the intake manifold to reduce combustion temperature and formation of NO_x. The exhaust gas is relatively at low temperature and absorbs heat from the much hotter combustion process. There by reduces combustion temperature and hence formation of NO_x.

The simplest form of EGR system is as shown in figure. It consists of a passage which connects exhaust manifold and intake manifold. The EGR valve opens and closes the passage and it consists of a spring loaded diaphragm that forms a vacuum chamber at the top of the valve. A tube connects vacuum chamber and vacuum port in the throttle body as shown in figure. In absence of vacuum, the diaphragm moves down due to spring action, thus closes the passage. In this situation, no exhaust gas re-circulates, engine is idle and formation of NO_x is minimum.

When the throttle opens, it moves past the vacuum port. This allows the intake manifold vacuum to act through the port and moves the diaphragm up to open the valve. As the valve rises up, some exhaust gases passes through the valve in to intake manifold. The exhaust gases mixes with air-fuel mixture and then enters into engine cylinders. This reduces combustion temperature and hence formation of NO_x.

When the throttle valve is fully opened, a little vacuum exists at the vacuum port and hence EGR valve is nearly closed. However no EGR is needed due to rapid combustion and there is less time for NO_x formation. In most of the engines, vacuum is applied to the EGR valve through a ported vacuum switch (PV) or thermal vacuum switch (TVS). It prevents EGR until engine temperature reaches 38°C .

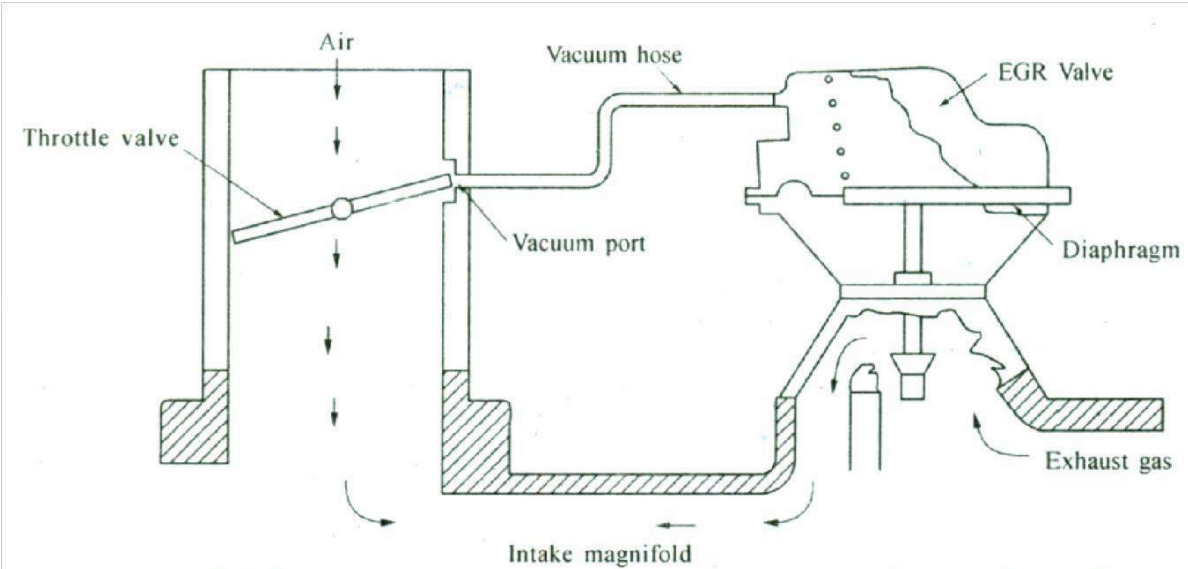

Fig: - Schematic diagram of EGR system

❖ **Treating the exhaust gas:**

The exhaust gas is treated before it enters in to atmosphere, to reduce amount of HC, CO and NOx. This is done by injecting fresh air into the exhaust system and b passing exhaust gas through a catalytic converter.

Air injection system

In this method, the fresh air is blown into the exhaust gases after they exit combustion chamber. This provides additional oxygen to burn HC and CO coming out of cylinders and converts them into water and CO₂and reduces amount of these pollutants.

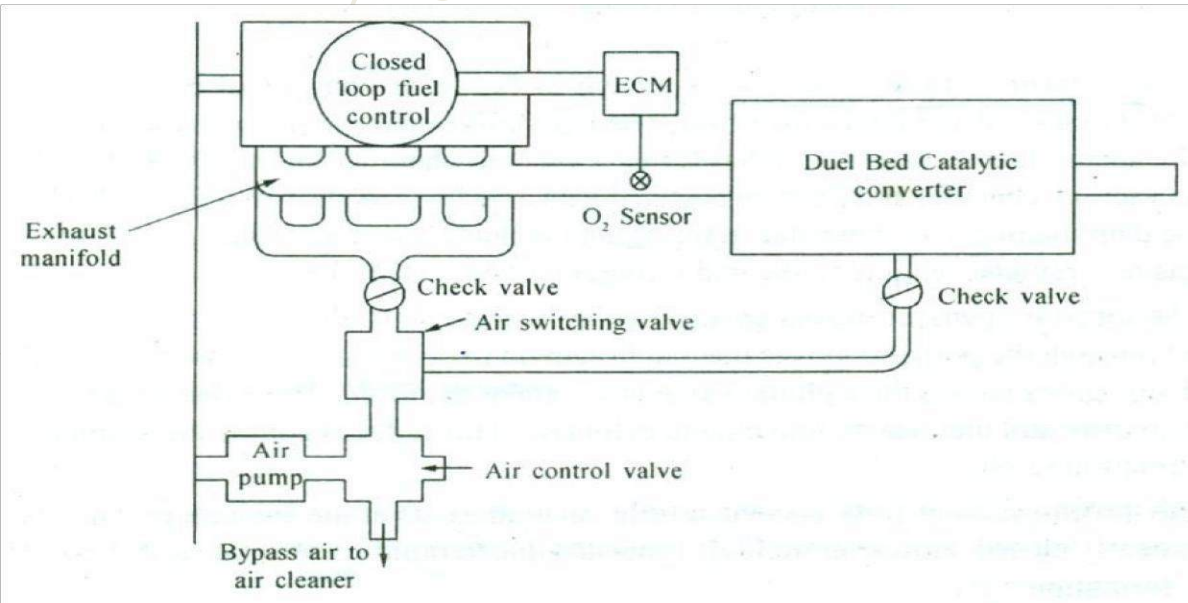

Fig: - Air injection system

The Air injection system consists of air pump, air switching and control valves and the one way check valves. When the engine is cold, the air pump pushes air through nozzles to the exhaust manifold. The nozzles are located opposite to exhaust ports and hence O_2 in the air helps to burn any HC and CO in the exhaust gas in the exhaust manifold.

When the engine warms up, ECM causes the air to pass through catalytic converter, where HC and CO is converted into H_p and CO . The check valve avoids back flow of exhaust gases to the air pump incase of back fire. During deceleration, the bypass valve momentarily diverts air from air pump to the air cleaner, instead of to the exhaust manifold. This avoids back firing in the exhaust system.

Air aspirator System

Some Engines uses air aspirator valve in place of air pump. This is a one way check valve. The opening and closing of exhaust valve causes variation in the exhaust manifold pressure. When this exhaust pressure is below atmospheric, fresh air admits through air aspirator valve to the nozzles in the exhaust manifold.

The air aspirator valve closes when exhaust valve opens which causes pressure in the exhaust manifold to increase above atmospheric.

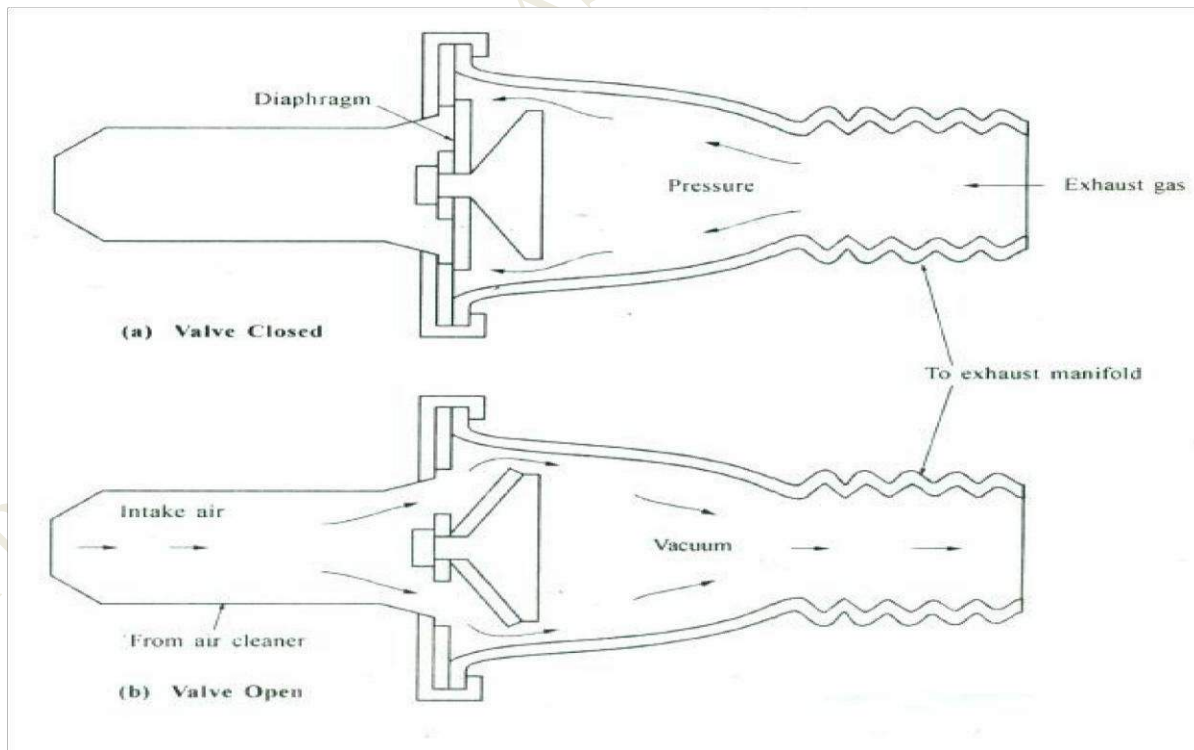

Fig:- Air aspirator valve

CATALYTIC CONVERTER

The function of catalytic converter is to treat the exhaust gas to convert harmful pollutants into harmless. All exhaust gases must pass through catalytic converter which is located in exhaust system. The catalytic converter consists of a material called catalyst which causes a chemical change without entering into chemical reaction. It makes two chemicals to react with each other and hence reduces amount of HC, CO and NO_x in the exhaust gases.

It consists of two different catalysts, one to treat HC and CO and other to treat NO_x. The first catalyst promotes HC to unite with O₂ to produce H₂O and CO₂. The second catalyst promotes CO to react with O₂ and hence to release CO₂, as this converter oxidizes HC and CO, it is known as oxidizing converter. The platinum and palladium are listed as oxidizing catalysts.

The catalyst used for NO_x, splits O₂ and N₂ and hence NO_x becomes harmless N₂ and O₂. The converter is known as reducing converter and metal rhodium is used for this purpose.

A large surface area of catalytic converter is coated with catalyst. The coated surface area or substrate is in the form of a bed of small beads or pellets or a ceramic honey comb. Usually honeycomb converter is round and pellet type converter is flat.

The vehicles fitted with catalytic converter in the exhaust system must use unleaded gasoline otherwise lead in the gasoline coats the catalyst and makes the converter ineffective. The air fuel ratio for the mixture must be stoichiometric ratio for effective working of the catalytic converter.

Basic Catalytic Converter

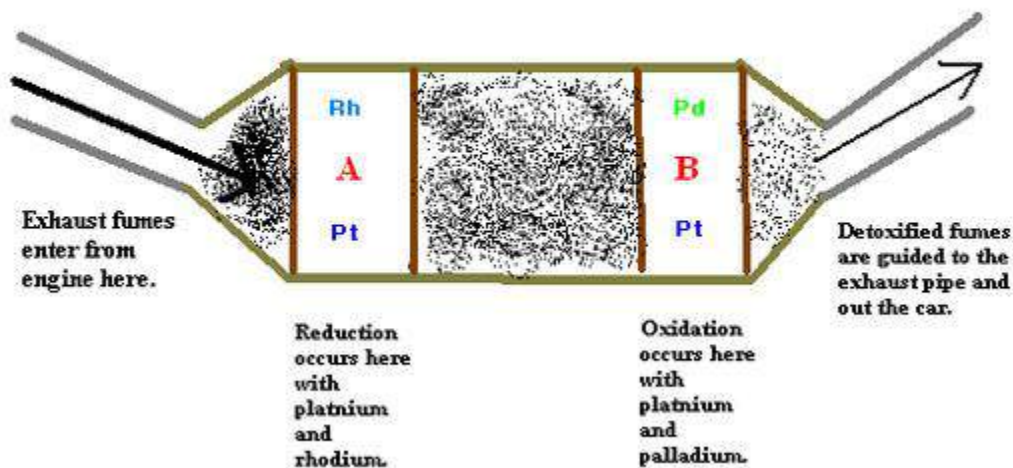

Dual Bed and Three way catalytic converters

A dual bed catalytic converter consists of two pellet beds, one over the other and are separated by an air chamber. The pellets coated with three way catalyst reduce NO, into N₂ and O₂ is provided on the upper bed. It also helps to oxidize HC and CO. The lower bed acts as two way catalyst and oxidizes remaining HC and CO. When the vehicle warms up, the air pump supplies secondary air to the air chamber to separate the upper and lower beds.

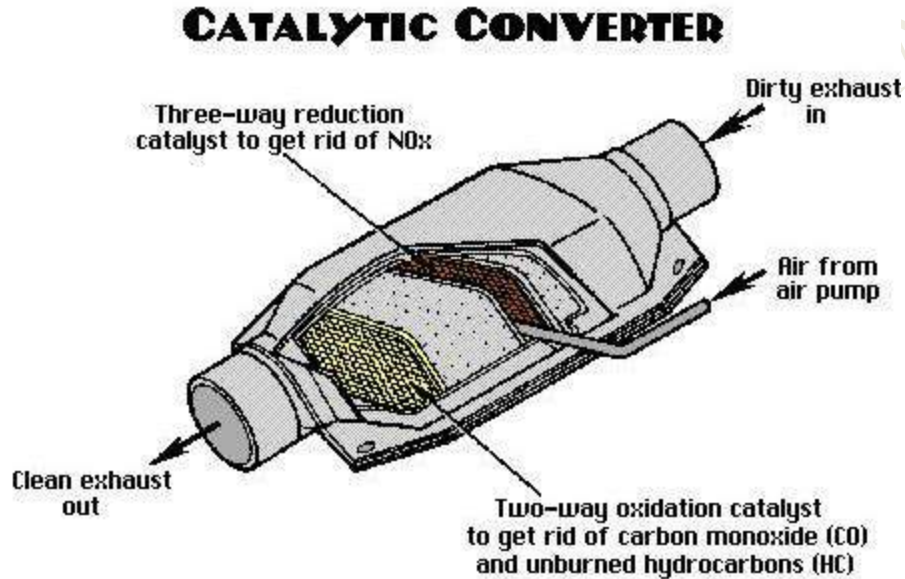

EMISSION STANDARDS

As vehicle populations grow and cities become more congested the allowable emissions from engines have been lowered to maintain air quality in major cities. The pollutants from vehicles cause several health problems, leads to formation of smog and affects environment. Many countries are aiming at achieving safe concentrations of these pollutants by regulating their level of emissions. Emission standards are requirements that set specific limits to the amount of pollutants that can be released into the environment. These emission standards regulate pollutants released by automobiles, industry, power plants and diesel generators etc. Generally these standards regulate the emissions of nitrogen oxides, sulfur oxides, particulate matter (PM) or soot, carbon monoxide and volatile hydrocarbons. These emission standards puts limits for conventional pollutants and regulate green house gases particularly carbon dioxide. In USA, emission standards are managed by the Environmental Protection Agency. In the state of California, California's emission standards are set to influence emission requirements that major

automakers must meet. The European Union has set its own emission standards for all road vehicles, trains, barges etc. No standards apply to seagoing ships or aero planes. The European Union has introduced Euro 4 from 1-1-2008, introducing Euro 5 from 1-1-2010 and Euro 6 from 1-1-2014. Many of the other countries also conform to the euro 4 standards from Jan 2009. In 198~ India introduced first Indian emission regulations to limit idle emissions. From 2000 India started adopting European emission and fuel regulations for four wheeled light duty and for heavy duty vehicles. Indian owned emission regulations still apply to two and three wheeled vehicles. All transport vehicles must have a fitness certificate that is renewed each year after the first five years of new vehicle registration.

On October 6, 2003, the National Auto Fuel Policy has been announced which envisages a phase I-program for introducing Euro 2-4 emission and fuel regulations by 2010. The table 1 shows the implementation schedule of EU emission standards in India.

Table .1

Standard	Reference	Date	Region
India 2000	Euro I	2000	Nation wide
Bharat Stage II	Euro2	2001	Delhi, Mumbai, Kolkata, Chennai
		2003,04	Delhi, Mumbai, Kolkata, Chennai, Hyderabad, Ahmedabad, Pune, Surat, Kanpur and Agra
		2005,04	Nation wide'
Bharat Stage III	Eur03	2005,04	Delhi, Mumbai, Kolkata, Chennai, Hyderabad, Ahmedabad, Pune, Surat, Kanpur and Agra
		2010,04	Nation wide
Bharat Stage IV	Eur04	201"0,04	Delhi, Mumbai, Kolkata, Chennai, Hyderabad, Ahmedabad, Pune, Surat, Kanpur and Agra

For Two and Three wheelers, Bharat Stage II (Euro 2) was recommended from April 1, 2005 and Stage III (Euro 3) was applied from April 1,2008.

Table 2 Emission Standards for Diesel Truck and Bus Engines, g/kWh

Year	Reference	CO	HC	NOx	PM
1992	--	17.3 - 32.6	2.7 - 3.7	----	-----

1996	- -	11.20	2.40	14.4	- -
2000	Euro I	4.5	1.1	8.0	0.36
2005	Euro II	4.0	1.1	7.0	0.15
2010	Euro III	2.1	0.66	5.0	0.10

Table 3 Emission Standards for Light-Duty Diesel Vehicles, g/km

Year	Reference	CO	HC	HC+NO _x	PM
1992	-	17.3 - 32.6	2.7 - 3.7	-	-
1996	-	5.0 - 9.0	-	2.0 - 4.0	~
2000	Euro I	2.72 - 6.90	-	0.97 - 1.70	0.14 - 0.25
2005	Euro2	1.0 - 1.5	-	0.7 - 1.2	0.08 - 0.17

Table 4 Emission Standards for Light-Duty Diesel Engines, g/kWh

Year	Reference	CO	HC	NO	PM
1992	-	14.0	3.5	• 18.0	-
1996	-	11.20	2.40	14.4	-
2000	Euro I	4.5	1.1	8.0	0.36*
2005	Euro II	4.0	1.1	7.0	0.15

Table 9.5 Emission Standards for Gasoline Vehicles (GVW s 3,500 kg), g/km

Year	Reference	CO	HC	HC+NO
1991	-	14.3-27.1	2.0 - 2.9	, -
1996	-	8.68 - 12.4	-	3.00 - 4.36
1998*	-	4.34 - 6.20	-	• 1.50 - 2.18
2000	Euro I	2.72 - 6.90	-	0.97 - 1.70
2005	Euro II	2.2 - 5.0	-	0.5 - 0.7

* for catalytic converter fitted vehicles

Table 6 Emission Standards for 3-Wheel Gasoline Vehicles, g/km

Year	CO	HC	HC+NO _x
1991	12 - 30	8 - 12	

1996	6.75	-	5.40
2000	4.00	-	2.00
2005 (BSII)	2.25	-	2.00

Overview of the emission norms in India

- I. 1991 - Idle 'CO' Limits for Gasoline Vehicles and Free Acceleration Smoke for Diesel Vehicles, Mass Emission Norms for Gasoline Vehicles.
2. 1992 - Mass Emission Norms for Diesel Vehicles.
3. 1996 - Revision of Mass Emission Norms for Gasoline and Diesel Vehicles, mandatory fitment of Catalytic Converter for Cars in Metros on Unleaded Gasoline.
4. 1998 - Cold Start Norms Introduced.
5. 2000 - India 2000 (Eq. to Euro I) Norms, Modified IDC (Indian Driving Cycle), Bharat Stage II Norms for Delhi.
6. 200 I - Bharat Stage II (Eq. to Euro II) Norms for all Metros, Emission Norms for CNG & LPG Vehicles.
7. 2003 - Bharat Stage II (Eq. to Euro II) Norms for I I major cities.
8. 2005 - From I April Bharat Stage III (Eq. to Euro III) Norms for I I major cities.
9. 20 I 0 - Bharat Stage III Emission Norms for 4-wheelers for entire country whereas Bharat Stage - IV (Eq. to Euro IV) for I I major cities. Bharat Stage IV also has norms on OBD (similar to Euro III but diluted).

Catalytic converters have been instrumental in reducing emissions of harmful gases from vehicles since their inception in response to the US Clean Air Act of 1970. Regulated emissions have been reduced approximately 1/3 while the number of cars on the road have more than doubled. Platinum, palladium and rhodium are essential components in automobile catalytic converters reducing engine-out emissions by well over 90%, and in some cases by over 99%.

QUESTIONS

Explain the working of EGR system

Write a short note on air injection system and air aspirator valve

Write a short note on emission standards.

With neat sketch and explain catalytic convertor.

Explain the working of evaporative control system for fuel injected engines.

Explain the various methods used to reduce pollutants in the exhaust gas.

With neat sketch and explain thermostatic air cleaner.

Write a short note on controlling combustion process and exhaust gas recirculation.