

# Conserving Textiles

STUDIES IN HONOUR OF ÁGNES TIMÁR-BALÁZSY



MISSA DI  
SANTA VIRGINIA  
DI LUDOVICO  
MESSALE DI  
LUDOVICO  
SANTA PIRELLA  
SANTA MARIA DEL SANGUE  
SANTA GIOIA  
SANTA GIUSTINA  
SANTA ANTONIA  
SANTA CATERINA

# Conserving Textiles

STUDIES IN HONOUR OF ÁGNES TIMÁR-BALÁZSY

ORIGINAL HUNGARIAN VERSION EDITED BY:  
István Éri

EDITORIAL BOARD:  
Judit B. Perjés, Katalin E. Nagy, Márta Kissné Bendefy,  
Petronella Mravik Kovács and Enikő Sipos



Conserving Textiles: Studies in honour of Ágnes Timár-Balázi

ICCROM Conservation Studies 7

ISBN 92-9077-218-2

© ICCROM 2009. Authorized translation of the Hungarian edition © 2004 Pulszky Hungarian Museums Association (HMA).

This translation is published and sold by permission of the Pulszky HMA, the owner of all rights to publish and sell the same. The publishers would like to record their thanks to Márta Kissné Bendefy for her immense help in the preparation of this volume, to Dinah Eastop for editing the English texts, and to Cynthia Rockwell for copy editing.

ICCROM International Centre for the Study of the Preservation and Restoration of Cultural Property

Via di San Michele 13

00153 Rome, Italy

[www.iccrom.org](http://www.iccrom.org)

Designed by Maxtudio, Rome

Printed by Ugo Quintily S.p.A.



## *In memoriam: Ágnes Timár-Balázszy (1948–2001)*

**Á**gnes Timár-Balázszy was an inspirational teacher of conservation science and she will be remembered as a joyful and passionate person, with vision, intelligence and the ability and willingness to work very hard. She loved both teaching and travel and developed a network of friends and colleagues all over the world.

Ágnes began her career in 1966 as a metal, ceramics and glass conservator at the Hungarian Central Museum Technology Group, then at the Institute of Conservation and Methodology of Museums, the National Centre of Museums, and finally at the Conservation Department of the Hungarian National Museum. She took a degree in chemical engineering at the Budapest Technical University in 1975, a further degree in 1985 and was awarded a PhD degree in 1997. Her doctoral dissertation focused on the dye analyses of museum textiles.

From 1974 onwards she contributed to the training of Hungarian conservators and remained committed to improving the standards and status of Hungarian conservation and conservation training. In 1991 she was instrumental in establishing a programme in conservation training as a successful collaboration between the Hungarian University of Fine Arts and the Hungarian National Museum. Ágnes loved Hungary and was proud of its rich cultural heritage and strong museum sector. She was a gifted linguist and disseminated the results of Hungarian conservators' work and conservation training at an international level. She fostered international links, for example by co-organizing the International Restorer Seminars in Veszprém, Hungary.

Ágnes became well known around the world as a teacher of chemistry and of the scientific background of textile conservation for professionals. She taught regularly on international conservation courses at ICCROM in Rome as well as at the Textile Conservation Centre in Britain, the Abegg-Stiftung in Switzerland and in Hungary. Ágnes also taught in Austria, Chile, Finland, Ghana, Israel, Nigeria and Zambia. Hundreds of conservators benefited from her knowledge and enthusiasm. One outcome of her teaching was the publication in 1998 of *Chemical Principles of Textile Conservation*, co-authored with Dinah Eastop. She was proud of its many reprints and was always delighted to see well-thumbed copies in conservation workshops. As well as teaching, Ágnes carried out important research into the analysis of historic dyes and the cleaning of historic textiles. She was particularly proud to contribute to the investigation of the dyes of the Hungarian coronation mantle.

Ágnes succeeded Judith Hofenk de Graaff and Mechthild Flury-Lemberg as coordinator of the ICOM Conservation Committee Textile Working Group, which she led between 1990 and 1996. She became a member of the ICCROM Council from 1994 to 2001, and Vice-Chairperson of the ICOM Conservation Committee from 1999.

In 2001, Ágnes posthumously received the ICCROM Award in recognition of her outstanding contribution to the field of cultural heritage preservation.



# Contents

**In memoriam** iii

---

- 1 Conservation of silk finds dating to the Anjou period (1301-1387)** 1  
JUDIT B. PERJÉS, KATALIN E. NAGY AND MÁRTA TÓTH

---

- 2 Excavation of the crypt of the Dominican Church in Vác: preserving coffins, dress and other funerary paraphernalia, 1731-1808** 20  
JUDIT B. PERJÉS, EMIL RÁDULY AND MÁRIA ÚJVÁRI

---

- 3 The conservation of two medieval parchment codices** 33  
ILDIKÓ BEÖTHY KOZOCSA

---

- 4 Conservation decision-making: from object to collection to community and back again** 39  
DINAH EASTOP

---

- 5 The image of a crucified man on the Turin Shroud: measures taken for conservation of the legibility of the body image** 43  
MECHTHILD FLURY-LEMBERG

---

- 6 An eighteenth-century Hungarian court dress with nineteenth-century alterations: an example of historicism in the collections of the Hungarian National Museum** 52  
KATALIN DÓZSA

---

- 7 Dyeing black in seventeenth-century Holland** 60  
JUDITH H. HOFENK DE GRAAFF

---

- 8 Metal thread variations and materials: simple methods of pre-treatment identification for historical textiles** 68  
MÁRTA JÁRÓ

---

---

|           |                                                                                                                                                           |     |
|-----------|-----------------------------------------------------------------------------------------------------------------------------------------------------------|-----|
| <b>9</b>  | <b>Assessing the risk of wet-cleaning metal threads</b><br>KATIA JOHANSEN                                                                                 | 77  |
| <b>10</b> | <b>Eastern and Western influences on Hungarian footwear of the thirteenth-seventeenth centuries</b><br>MÁRTA KISSNÉ BENDEFY                               | 87  |
| <b>11</b> | <b>Problems of the second restoration of two general's atillas (military coats) from 1848/49</b><br>MÁRIA KRALOVÁNSZKY                                    | 97  |
| <b>12</b> | <b>Academic training of conservator-restorers in Austria: past experiences and future perspectives</b><br>GABRIELA KRIST                                  | 103 |
| <b>13</b> | <b>Lace from the Secession (Hungarian Art Nouveau): sewn, coloured lace articles</b><br>EMŐKE LÁSZLÓ                                                      | 106 |
| <b>14</b> | <b>The conservation of the painted cloth travelling 'tapestry' of Ferenc Rákóczi II</b><br>GYÖRK MÁTÉFY                                                   | 112 |
| <b>15</b> | <b>The philosophy of restoration: new for old?</b><br>ANDREW ODDY                                                                                         | 117 |
| <b>16</b> | <b>Bulya vászon: a type of loosely woven cloth</b><br>EMESE PÁSZTOR                                                                                       | 124 |
| <b>17</b> | <b>Restoration of an embroidered board game</b><br>ANIKÓ PATAKI                                                                                           | 131 |
| <b>18</b> | <b>Conservation of ancient Egyptian painted artefacts</b><br>ANNE RINUY                                                                                   | 141 |
| <b>19</b> | <b>The evolution of conservation and restoration as reflected in the Coptic textile collection of the Textile Museum of Lyon</b><br>MARIE SCHOEFER-MASSON | 147 |
| <b>20</b> | <b>Figures from a Neapolitan nativity crèche</b><br>ENIKŐ SIPOS                                                                                           | 157 |
| <b>21</b> | <b>The conservation of the flag of the Loránd Eötvös University</b><br>NIKOLETT SZEDERKÉNYI                                                               | 165 |

---

---

|           |                                                                    |     |
|-----------|--------------------------------------------------------------------|-----|
| <b>22</b> | <b>The symbolic meaning of red in seventeenth-century clothing</b> | 173 |
|           | LILLA TOMPOS                                                       |     |

---

|  |                     |     |
|--|---------------------|-----|
|  | <b>Bibliography</b> | 182 |
|--|---------------------|-----|





Between 1998 and 2000, finds in extraordinary profusion and of a unique quality were excavated by archaeologists of the Budapest Historical Museum on an 8,000 sq m stretch lying west of Szent György square in the Buda Castle.<sup>1</sup> The archaeologist Dorottya Nyékhelyi, in charge of the excavation at well no. 8 of the Teleki Palace, still supplied by fresh water rivulets, uncovered hundreds of ceramic dishes, wooden objects (spoons, casks, dishes, troughs and carvings), as well as leather footwear and wooden caskets covered in leather. Textiles of various sizes also came to light during the excavation. The conservation of these finds is bound to continue over many years. A rather concentrated layer of black peat, metres deep (composed of seeds and wood debris apart from the already mentioned historically significant objects), had preserved the objects. What follows is a description of the conservation of the silk cloth with the Hungarian and Anjou Coats of Arms (referred to below as the Anjou Cloth), fragments with oak-leaf-and-flower patterns, and spearhead-shaped, acorn-topped fragments.

JUDIT B. PERJÉS, KATALIN E. NAGY AND MÁRTA TÓTH

## Conservation of silk finds dating to the Anjou period (1301-1387)

### Excavation

An initial cleaning of objects recovered from the well, which was brimming with sludge, was undertaken simultaneously with the ongoing excavation. This consisted of extracting the objects from the enveloping mud. Immediate transportation of finds to the restorers' workshop was facilitated by its proximity to the site. The restorers carried out a preliminary cleaning of the objects grouped according to their material (wood, metal, ceramics, glass, leather or textile). In the case of wooden and leather objects, conservation commenced immediately. An exceptional piece among the silk finds was the Anjou Cloth, which arrived at the laboratory on Friday, 4th October 1999, encased in a solid block of mud and packed in plastic foil. The mud-block packs containing the two other silk fragments were brought out of the well a few days later. The finds had lain at nearly the same depth.<sup>2</sup> (Figs. 1-3)

The good condition of the silk material is explained by the fact that the fragments had been in the oxygen-free environment of the mud, and in a state of equilibrium through the centuries with only slight variations in temperature. The peat was pH 9. In theory, alkaline conditions are unfavourable to both leather and silk materials, but experience has shown that lack of contact with oxygen and a fixed temperature are the most important conditions for the preservation of archaeological finds.

Following excavation, restorers of the Budapest Historical Museum kept the textile items damp and cool, and wrapped in polyethylene sheeting. The prolongation of the state of equilibrium was of fundamental importance in this instance. A sudden change in the textiles' environmental conditions (e.g. temperature, humidity or light exposure) after excavation had to be avoided. Irreparable damage could have been caused to the partially disintegrated textile structures if they had suddenly dried out.



FIGURE 1 Well under excavation, detail

FIGURE 2 The Anjou Cloth as recovered, caked in a single block of mud

FIGURE 3 The mud containing the oak-leaf-and-flower patterned fragments

## Preliminary cleaning

The solid block of mud containing the Anjou Cloth could not have been unpacked without immersion in water. After sixteen hours under water, the silk had loosened enough to allow it to be spread out without tearing.<sup>3</sup> Unaware of the size or form of the piece of silk, it was first allowed to soak in a smaller plastic dish and was only later put into a large photo-developing tray. Ultimately, the find with an unprecedented capacity for expansion was moved to a specially constructed wash bath with polyethylene net spread in it, where the material could unfold completely with gentle manipulation. The underlying net not only insured safety in handling the material, but also helped with the removal of small bits of dirt, such as seeds, other vegetal remnants and pebbles. A similar procedure was implemented for the preliminary cleaning of the silk fragments with oak-leaf-and-flower patterns and the spearhead-shaped, acorn-topped fragments.

Deionized water, without added surface-active agents, was used for wet cleaning. A disinfectant (in a concentration of up to 0.1%<sup>4</sup>) was added to the water because *coli* bacteria, known to cause inflammations in the human body, were identified in the sludge from the well during health inspections.

## Preliminary cleaning results

In spite of deformations in the Anjou Cloth, the base fabric had become less brittle, and the characteristics of each piece became apparent after repeated cleaning and soaking in the deionized water. The main types of cloth could also be distinguished. The ragged, crumpled edges had smoothed out, the glow returned to coloured surfaces, and dimensions could be ascertained with relative accuracy. Only some light-grey patches (barely a few square millimetres in area) remained caught in the threads of the material, these came from the stone substances in the wall of the well. They could not be removed altogether, even later, in the process of conservation. The finds were then kept under suitable conditions, covered and laid out for a few months,<sup>5</sup> until work could be continued. Following the first-aid cleaning, the archaeologist László Dinnyés, the draughtsman of the Budapest Historical Museum, made drawings of the finds for archaeological research.

An expert committee decided what was to happen with these textile finds of exceptional importance.<sup>6</sup> The group of finds was moved from the Budapest Historical Museum to the Textile Conservation Laboratory of the Museum of Applied Arts, where all the equipment necessary for conservation of the textiles was at hand. Restorers appointed by the committee prepared a preliminary work plan, which was then accepted by



FIGURE 4 The silk cloth fragment after preliminary cleaning



FIGURE 5 Illustration for the condition report, demarcation of fields 1 to 47

a jury of experts.<sup>7</sup> In devising a plan for the artefacts' preservation, the guiding principle was choosing methods involving only the most necessary intervention. No formal or aesthetic completion (in-filling) was undertaken, because the purpose was to stress the fragmentary nature of the finds.<sup>8</sup>

## Description of finds

### Anjou Cloth

The Anjou Cloth was composed of five individual fragments. Adjoining fragments could be arranged into groups composed of twelve Hungarian coats-of-arms (whole rue coats-of-arms), twelve halved rue coats-of-arms and two segments of rue coats-of-arms, fifteen Anjou coats-of-arms (whole rue coats-of-arms), as well as three half and three incomplete coats-of-arms. The original colours of seven of the Hungarian coats-of-arms were red and white. On the once-blue Anjou coats-of-arms four *fleurs de lis* of yellow silk were sewn, and a lambel<sup>9</sup> of red silk was placed on the lily at the top.

Dimensions:

1. L: 2390 mm, W: 1050 mm
2. L: 970 mm, W: 340 mm
3. L: 345 mm, W: 320 mm
4. L: 120 mm, W: 60 mm
5. L: 100 mm, W: 60 mm

(Figs. 4-5)

When investigation of the fragments showed that it was possible to reassemble them, an illustration of

their condition was prepared. The forty-seven fields were outlined on the drawing, as well as the five separate fragments, the edges of each cloth, the sewn edges and the stitches joining the coats-of-arms. The hems were examined for clues to indicate the original height and width of the Anjou Cloth. Visible on three sides of the Anjou Cloth were the edges of fields 1, 2, 3, 7, 21, 35, 37, 40, 42, 44, 45, 46, where the silk material had been folded back. However, hems on the top and bottom provided equivocal evidence in determining the original height of the cloth; that the original edge of the cloth was at the hem on the top is mere conjecture.

No lambel could be found on the lilies in fields 13, 27 and 41 (found to the right of the cloth), nor were there any stitch marks to prove that they had ever been there. This gave rise to the premise that this had been the cloth's right side, perhaps with a border serving as a line of closure. No explanation was found for the fabric folded back in fields 21 and 35. The pattern of repeated coats-of-arms did not offer any reliable point of reference for the reconstruction of what the original size had been. (Figs. 6-7) Stitches that could be deciphered on the front of the cloth, along with the silk-thread remnants that were to be found on its reverse, allowed the assumption that it had originally been made with a quilting technique. No remaining *lining and padding material* was found to substantiate this premise when the cloth was dismantled; this suggests that it found its way into the well without these components. (Fig. 8)

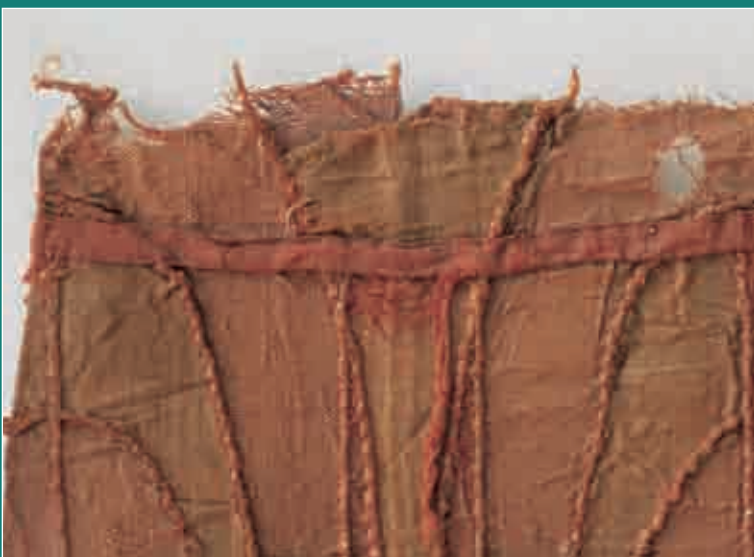

FIGURE 6 Edge of field no. 35, viewed from the front

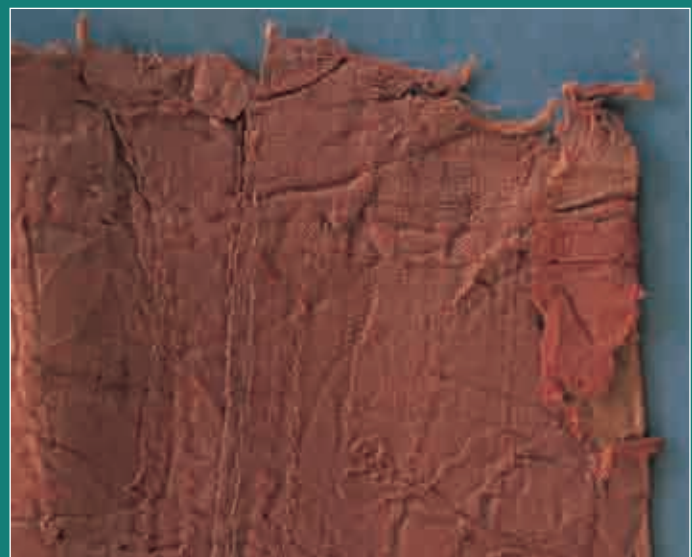

FIGURE 7 Edge of field no. 35, viewed from the reverse



### Textile fragments with oak-leaf-and-flower patterns

Four pieces of the fragments were alike, whereas two were mirror images, depicting something reminiscent of branches with oak leaves.

The main motif is a vertical stem with little leaves bending out right and left. Two-thirds up the stem, a vigorous tendril continues, carried on in a falling branch with leaves, to end in a flower with five petals. The flower turns towards the vertical stem, forming a beautifully curving unit at the centre of the motif. The outlining threads of the silk fragments emphasize the vitality of the plant motif and delineate the leaf veins. Size: ca. 260 x 260 mm. (Fig. 9)

### Spearhead-shaped, acorn-topped fragments

The three textile fragments shaped like leaves, but also reminiscent of spearheads, have short stems branching in two directions at their base, and an acorn shape at their points, with an insert shaped like an oak leaf in the centre of the spearhead form. Threads outline both the motif and the insert. The leaf veins are also emphasized by outlining threads. Size: Length: 430 mm; maximum width: 90 mm; insert length: 180 mm (Fig. 10)

## Investigation of materials and technology

### Production technology

The silk finds described above are historical artefacts of outstanding significance, testifying to the artistic achievements in textiles at the Hungarian Anjou Court. There are many references to objects decorated



FIGURE 8 Traces of quilt stitching visible on the reverse of field no. 12

FIGURE 9 Detached fragment with oak-leaf-and-flower patterns

FIGURE 10 The detached spearhead-shaped, acorn-topped fragments.

with heraldic coats-of-arms in Hungarian sources, but until now there has been no information about how they were made. Splendid palaces and cathedrals, built from the thirteenth century onwards, and their furnishing gave a huge impetus to the arts and crafts, with embroidery among them. Celebrations, hunts and travels afforded ample occasion for elaborate dressing and the ornamentation of palatial halls with decorative wall hangings.<sup>10</sup> (Fig. 11)

Royal commissions in the beginning of the century escalated apace. This may have been why an artist working either in the immediate surroundings of the royal house or in a guild found the rapid reproduction of works designed by him a matter of paramount importance when it came to execution. This made simplification of the production process necessary, which in turn led to the widespread use of methods and tools that took the brunt off labour. There were instruments of various sorts that made it possible for the artist to place a given pattern (or certain elements from it) directly upon the base of the final composition, speeding up the process of manufacture and allowing for repeated duplications.<sup>11</sup>

The appliqué technique (called *opus consutum*) was a simple and quick method of achieving a decorative effect. Only a few objects made in this manner are extant, but sources prove that its use was widespread. The speed of production is well illustrated by the following example: the armourer au Roy et brodeur, Nicholas Waquier, was tasked on the 8th of September 1352 with the preparation of a velvet horse-covering and room-hanging decorated with fleurs de lis for All Saints' Day. In the short time available, 8,544 embroidered lilies would have to be manufactured and stitched onto the various textiles. The lilies were of course in production constantly, and the embroiderers were helped in their effort by large quantities of wine and candles.<sup>12</sup> The accounts left by the heads of workshops show the type, cost and quality of materials ordered, and wages per head. Labour was very cheap; information on labourers in debt can also be found. The names of the workers are mentioned very often, with details as to the number, expertise, pay scale and ratio of women to men employees.

Philippa, Queen consort,<sup>13</sup> ordered three embroidered blankets for church ceremonies in 1330. An artist and a designer commanded a group of labourers numbering 112 persons:

70 men were employed at wages of four and a half dinars/day

42 women were employed at wages of three and a half dinars/day

the artist was paid six and a half dinars/day

the designer was paid eight and a half dinars/day

It is not clear how work was distributed among the sexes, but it is likely that they were separated into three groups, and each prepared one blanket. The Queen's tailor, William de London, organized the purchase of everything required, making all necessary arrangements for the work. He oversaw the acquisition of the frames, strings, thick threads and needles, also ordering the fluffing up and beating of cotton/wool to be used as filling. He purchased wax as well, to seal the raw edges of silk. The bills and the fact that the wax, used before the motifs were cut out and set in their place, can be found on the edges of the embroidered silk motifs are a clear indication of this practice.<sup>14</sup>

The manner of preparing an under-drawing and the techniques of copying model drawings in the fourteenth century cannot have differed much from the methods explained in the handbook of the fifteenth-century painter of Florence, Cennino Cennini. The drawing was either made directly upon the material, which had been stretched on frames, or the design created earlier in advance was copied onto the final base. He also mentions the use of tailors' chalk<sup>15</sup> for drawing upon black or blue base materials and a wooden template for copying motifs.<sup>16</sup>

## Manufacture of the Anjou Cloth Pattern

The designer/producer of the Anjou Cloth might well have taken a similar approach. One of the possibilities for preparing the pattern of the coats-of-arms would have been cutting it out of parchment, which has the various motifs of the embroidery intarsia drawn onto it in ink, lead or tin pencil.<sup>17</sup> Then the parchment template would be placed on the cloth to draw the contours on the material. After having drawn the exact number of motifs appropriate to the design of the artwork, these were cut out of the material. Another possible means for replication may have been the use of tailors' chalk. In either case the frayed silk edges would have had to be reinforced with wax, so that the edge of the material did not deform or fray in the process of cutting and sewing. Signs of wax having been used were found on the reverse side of the Anjou Cloth, and also on the edges of the material.

In the case of the Anjou coats-of-arms, the necessary amount of rhomboid base materials, lilies and four-part patterns for the lambels were cut out first. Now, 21 pieces of rhomboid ground material (of a blue colour originally) can be found on the fragment of the cloth. In nine of the fields (nos. 7, 9, 10, 12, 21, 25, 35, 36, 37), the base fabric for the coats-of-arms was made by combining two pieces. The edge of the base material is clearly visible where the pieces were



FIGURE 11 Painting showing wall-hangings at the court of Philip of France (1285-1314)

### Making the Hungarian Coat-of-Arms

12 pieces whole rhomboids (rue coats-of-arms), 12 pieces of half rhomboids,  
2 pieces of rhomboid segment (side: 45-50 mm)



Pattern/Template  
or tailor's chalk



White silk fabric



Red silk fabric



### Making the Anjou Coat-of-Arms

9 pieces of whole rhomboids, 21 pieces of half rhomboids  
(side: 270-280 mm, diameter: 370-380 mm)

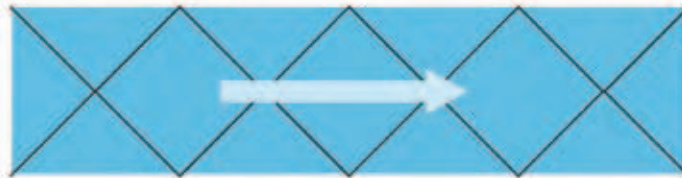

Warp direction

Fabric width: 450 mm



### Tailoring of the lilies

77 pieces of lilies  
(l. 150 mm, w. 125 mm)



Pattern template



Yellow silk

### Tailoring of the lambel

18 pieces of lambel, with four parts  
(l. 88 mm, w. 130-150 mm)



Red silk



FIGURE 12 The pattern of the Anjou Cloth



stitched together. The rhomboids were cut from silk cloth 40 mm wide.

The application of the pattern and the cutting of the material for the lilies of the Anjou coat-of-arms must also have been carried out by the means outlined above.

In nine fields (nos. 8, 10, 11, 22, 23, 24, 25, 37 and 38), the lilies were made from two pieces of cloth, and in 8 instances (in fields 22, 23, 37 and 38) the lower stem was also made from two pieces. These facts indicate a rather thrifty attitude toward materials on the makers' part. Four red and four white strips were cut from the silk cloth used for the Hungarian coats-of-arms.

### **Appliqué embroidery**

The implements used for the manufacture of the embroideries, such as the simple, adjustable wooden frame, the needles of different sizes or even thimbles, have remained effectively unchanged with time. Frames both propped up and horizontal were equally

in use, with their size adjustable for the particular needs of each piece. A thick thread or cord was used to stretch the cloth on the frame.

Embroidery for the Anjou Cloth would have been prepared in the same fashion. The rhomboid blue base material stretched on the frame, and the lilies pinned down upon it with a few stitches, applied just to prevent it from shifting while the contours were stitched on. A red silk thread outlining the lily is fixed to the ground fabric with a thinner thread. The red silk material of the horizontal bar of the lambel has been stitched without any outline, just folding back the edge of the material, while the vertical stems were fixed with outlining threads. (Fig. 13)

The Hungarian coats-of-arms could only have been made while held in the hand, not on a frame. The strips of fabric cut from the red silk were fixed with their reverse sides to the front side of the white silk material piece by piece. The rhomboid coats-of-arms would have been cut after the seven strips had been stitched together. (Fig. 14)



FIGURE 13 Anjou coat-of-arms, detail

## Assembly

The coats-of-arms prepared individually were stitched together. The Anjou coats-of-arms made up of appliqué embroideries were placed upon the Hungarian coats-of-arms and their edges were stitched together with running stitches. If seen from the reverse side, in most cases the Hungarian coat-of-arms is first, with the Anjou coat-of-arms folded back. The manner of assembly diverges in the case of fields 26, 38 and 39, with the Hungarian coat-of-arms superimposed, from which it may be deduced, that the embroidery was the work of numerous artisans. The material used as lining can only be

guessed at from marks left by the stitches. Numerous bits of extant silk thread used for the quilt stitches were found on the reverse of the embroidery. The pattern left by the quilt stitching was visible when the silk was viewed on a light box. (Fig. 16)

The quilt stitching on the Hungarian coats-of-arms was worked in a diamond grid pattern with a 15 mm spacing between the lines. The concentric pattern of quilting on the Anjou coats-of-arms is spaced at 10 mm, with the lilies and lambels left free so that they emerge in relief from the embroidery. (Fig. 17) The filling material for the Anjou Cloth must have been cotton/wool, which would have been



FIGURE 14 Hungarian coat-of-arms detail

FIGURE 15 Construction of the coats-of-arms, from the reverse

FIGURE 16 The pattern of holes made by quilt stitches, as seen on a light box

FIGURE 17 Marks showing the pattern of quilting stitches. (Copy made by the handicraft artist Renáta Rajcs)





FIGURE 18 A piece of ground fabric discovered on the reverse side of the spearhead-shaped silk fragment

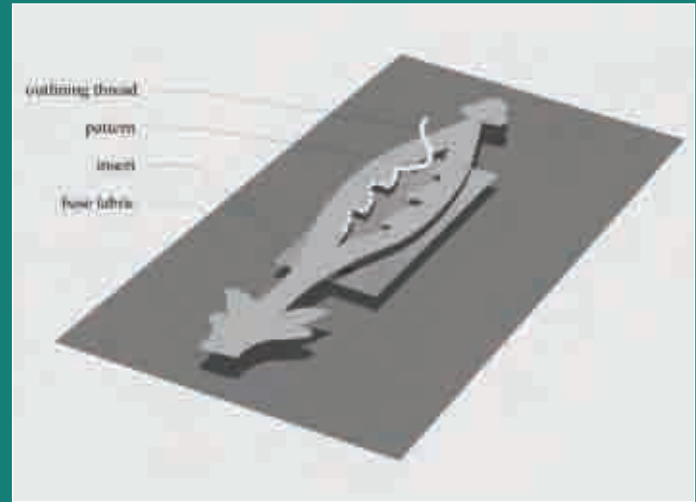

FIGURE 19 A technical drawing showing the technique used to make the spearhead silk fragments

secured with the quilting stitching. The appliqué embroideries would then probably have been lined with some fabric.

### Manufacture of the spearhead-shaped, acorn-topped fragments

These were most probably drawn up first according to a pattern, as observed in marks left by the procedure. The oak leaf shape was cut out of the centre of the spear-head shape: an inlay was placed under the hole. The forms were stitched onto the ground material with the outlining thread, a small segment of this material having been found on the reverse side of the embroidery. The outlining thread also lends emphasis to the stylized leaf veins. The association of the motifs in relation to one another has not been clarified, which means that their placement on the ground fabric is not conclusive.

### Manufacture of the textile fragments with oak-leaf-and-flower patterns

Oak leaves and flowers, cut from a square of silk material, had motifs traced onto them in advance, probably with the aid of a template. The underdrawings are clearly visible on the fragments. The motifs were in all likelihood edged with some kind of wax, while the leaf veins were traced with a line reminiscent of a thin, grey graphite pencil mark.<sup>18</sup> Stitches placed at 2-3 mm intervals secured the outlining thread and fastened the cut pieces to the ground fabric, of which no remains could be found. The drawn leaf veins were emphasized with stitches

worked in the outlining thread. The relationship between the various motifs is not clear in this case either, leaving doubts as to their arrangement when applied to the ground fabric.(Fig. 20)

### Dye identification<sup>19</sup>

#### Anjou cloth

The ground fabric of the Anjou coat-of-arms, which had originally been blue, changed to a light pinkish brown, but the yellow colour of the lilies and the red of the lambel had only faded. Of the red and

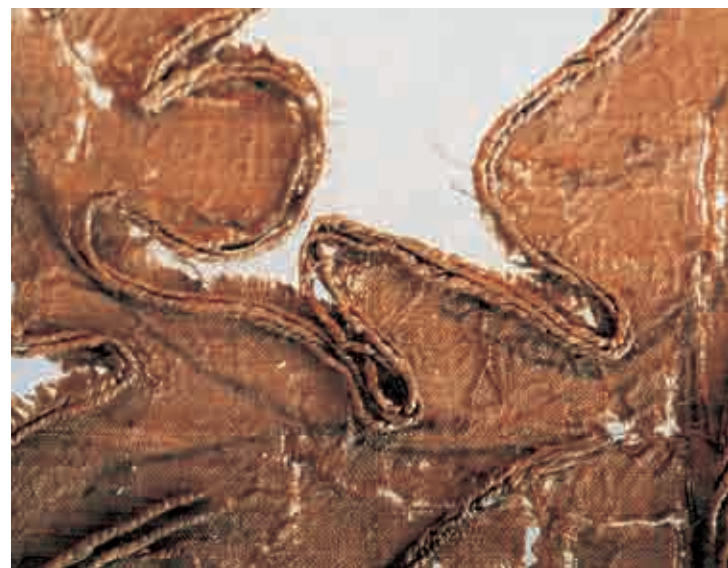

FIGURE 20 Edging on the fragments with oak-leaf-and-flower patterns

white stripes of the Hungarian coat-of-arms, the red had faded, while the white stripes had changed to a brownish yellow. Chromatographic examinations showed that the red colour was achieved with a mixture of colours extracted from kermes (*Kermes vermilo*), and madder (*Rubia Tinctorum*) with the addition of tannin. An extraction of the indigo dye for the blue ground fabric of the Anjou coats-of-arms could not be determined. Experts are of the opinion that the slightly alkaline environs had dissolved the colour base.<sup>20</sup> Mention must be made of kermes dye remains found on the sample taken from the once-white strip of the Hungarian coat-of-arms. The phenomenon can be explained by the slow dissolution of the colour in a wet and somewhat alkaline

state, which would have allowed it to permeate the undyed cloth.

### Fragments with oak-leaf-and-flower patterns

The colours of the fragments were of a light brown shade typical of archaeological finds. Dye analysis did not reveal any colouring agents used.

### Spearhead-shaped, acorn-topped fragments

The colour of these fragments was also of a light brown shade. Tests showed the presence of alizarin in the ground fabric, which hints at the use of madder. Signs of luteolin were established in the material used

## Material investigation

### Technological and material investigation of the Anjou textiles

#### FABRIC

| Silk Cloth                                                      | Warp | Weft | Weave   | Warp density | Weft density | Warp twining | Weft twining |
|-----------------------------------------------------------------|------|------|---------|--------------|--------------|--------------|--------------|
| Blue ground fabric of the Anjou coat-of-arms                    | silk | silk | taffeta | 36-40        | 36-40        | Z            | unspun       |
| Yellow fabric of the fleurs de lis                              | silk | silk | taffeta | 38-40        | 38-40        | Z            | unspun       |
| The coat-of-arms of the Árpád house beige fabric                | silk | silk | taffeta | 35-40        | 35-46        | Z            | unspun       |
| The coat-of-arms of the Árpád house red fabric                  | silk | silk | taffeta | 36-40        | 36-40        | Z            | unspun       |
| Lambel red fabric                                               | silk | silk | taffeta | 35-40        | 35-46        | Z            | unspun       |
| Fragment with oak-leaf-and-flower patterns                      | silk | silk | taffeta | 38-40        | 38-40        | Z            | unspun       |
| Spearhead-shaped, acorn-topped fragment                         | silk | silk | taffeta | 38-40        | 38-40        | Z            | unspun       |
| Oak leaf insert for the spearhead-shaped, acorn-topped fragment | silk | silk | taffeta | 35-40        | 50           | Z            | unspun       |

#### PRODUCTION TECHNOLOGY

| Sample                                     | Outlining thread for the overlay embroidery | Thread used to stitch the outlining thread | Sewing thread               | Application                              | Quilt stitching                                                     | Suspending string          |
|--------------------------------------------|---------------------------------------------|--------------------------------------------|-----------------------------|------------------------------------------|---------------------------------------------------------------------|----------------------------|
| Silk Cloth                                 | silk. unspun. red                           | silk, split strip, wound, S, red           | silk, split trip wound, S ? | Horizontal and pinned fastening stitches | The face of the applied material is covered with fastening stitches | flax or hemp strip wound S |
| Fragment with oak-leaf-and-flower patterns | as above                                    | as above                                   | as above                    | as above                                 |                                                                     |                            |
| Spearhead-shaped, acorn-topped fragment    | as above                                    | as above                                   | as above                    | as above                                 |                                                                     |                            |

for the oak leaf insert, indicating the use of weld. Tests on a sample of the spearhead-shaped fragment proved unsuccessful in establishing any dye.

## Conservation of the finds

### Anjou Cloth

#### Wet cleaning

No surface-active agents were used to clean the Anjou Cloth, since no contamination justifying their use had occurred. Following its recovery, the cloth was immersed in water and disinfected for a period of 24 hours to remove mud and various vegetal remains. If the applied silk fabric had undergone another lengthy cleaning process, it may well have suffered further deterioration. For this reason the material was only moistened so that the wet fabric could be arranged

according to its weave structure and original shape, as far as was possible in the case of such a crumpled and torn fabric. Deionized water was tamped on at this stage of the work, so that the artefact stayed as little as possible in a wet environment. The moistening took place on a polyfoam board<sup>21</sup> covered in foil, and an area of 20 x 20 mm was handled each time. All loose ends on the warp and weft, as well as the weave of the material itself, were set right and held in place with glass plates or entomological pins. Cold air was used to dry the cloth to avoid further fibre swelling. (Figs. 21a, 21b, 22)

#### Support

When making a choice for the support fabric and its colour, all materials and colours that were alien to the rules of heraldry were avoided. For support, the



FIGURE 21a Anjou Cloth as it is moistened and pinned in place

FIGURE 21/b Anjou Cloth, detail showing realigned silk weighted with glass plates and weights

FIGURE 22 Anjou Cloth, detail, as it dries to shape

FIGURE 23 Anjou Cloth, during conservation stitching

cloth was mounted onto a polycarbonate<sup>22</sup> board of a size equal to the dimensions of the cloth. Silk crepe-line<sup>23</sup> dyed black was applied over this, and after a stretching of the material a ribbon was stitched around its edge. The cut edge of the silk crepe-line was fastened on the back of the polycarbonate sheet, so that material of the thin fabric was not exposed to damage, but would also be stretched evenly.

The size of the Anjou Cloth was marked out on the now crepe-line-covered board with white thread. The transfer of the artefact from its position on the polyfoam to the board covered in crepe-line was carried out in the following manner: a thick canvas was placed on the front side of the artefact, clamping it down tightly with the insertion of needles along the side; the cloth was then turned so its reverse side was uppermost; the needles holding the canvas were then removed. The polycarbonate board was placed on top, and the canvas was fastened on again, and turned over. By these means the large, tattered artefact could be moved to its destination without risk of damage or wrinkling.

Prior to conservation stitching, a grid was prepared from yellow silk thread for the horizontal

and vertical lines of the diagonals of the coat-of-arms. This helped in aligning the fragments during conservation stitching.

First, the cut edges of the cloth were fastened to the crepe-line with running stitches. In this instance a widely used technique of conservation stitching was discarded because the extremely fragile silk material would have torn along the minute stitches. Loose warp and weft yarn, as well as the torn edges were sewn to the crepe-line with a running or where necessary the so-called 'laid and couched' stitch, using a yellowish brown, or reddish brown thread. (Fig. 23) After completion of the sewing work, the cloth was lifted off the polycarbonate sheet, the white ribbon removed from its edge and a trimming ribbon of black satin was sewn on after folding back the crepe-line. Since it was impossible to place the transparent silk material upon the bare polycarbonate sheet, both sides were covered with a black cotton material that was sewn into place. The cloth was then replaced upon the covered sheet, pinned down along the black satin ribbon on the reverse, and after checking whether the tension was right, it could be sewn on to the black cotton material.<sup>24</sup> (Fig. 24)



FIGURE 24 Anjou Cloth, after conservation

## Fragments with oak-leaf-and-flower patterns, and spearhead-shaped, acorn-topped fragments

### Cleaning

The process of cleaning began with soaking in soft water, swabbing and brushing with small brushes. Cleaning was then completed on a back-lit glass table. The fact that the contour lines had kept together many of the pieces of the silk motifs that had fallen apart, was a valuable aid in recovering and rejoining the threads, following the weave in connected segments. (Fig. 25) After careful cleaning, realignment of the grain and readjustment of the contour threads in all pieces, they were dried on the glass sheet. The contiguity of pieces was established in the process, as they were easily placed where they belonged on the glass table while still wet. The pieces stuck slightly to the glass surface, so they did not deform while drying. (Fig. 26)

After joining fragments 1 and 2 of those with oak-leaf-and-flower patterns it became clear that very little was missing, giving it a priority for cleaning. After they had dried, an approximation of their original shape could be established; this was drawn on Melinex foil and helped in recognizing pieces of other fragments. Four of the fragments from the oak-leaf-and-flower patterns have the same pattern, and two show a mirror image where the flower bends to the right. By turning over the drawing made on the transparent Melinex, the pieces of the fragments with their flowers bending to the right could also be set aright.

The cleaning of the spearhead-shape, acorn-topped fragments was also carried out on the glass pane. Since the outline threads had been effective in keeping the pieces together, the realignment of the grain of the fabric was greatly helped by the back-lighting.

### Conservation stitching

Before proceeding with the case of the fragments with oak-leaf-and-flower patterns, six sheets of polycarbonate (each 400 x 400 mm), fitted with a card mount measuring 300 x 300 mm, were prepared. Then the panels were covered in silk crepeline, fastened at the back of the plastic sheet in a way that gave it an even tension over its surface so that it provided a satisfactory base for stitching. The silk fragments, which had been cleaned and dried to shape, and were still on the glass panes, could now be placed on the mounts. The transferral could only be carried out with utmost care, since the process of detaching them from the glass could have dislodged the carefully aligned small pieces and outlining threads. Accordingly, the transfer could only be carried out in steps. (Fig. 27)

First the adhesion between silk fragments and the glass was eliminated using a thin spatula. A glass pane of similar shape was then laid over the surface of the object, and both panes of glass, held tight against one another, were turned upside down. The pane previously below, was now above the object, and could be carefully lifted off. The silk fragment lay face down upon the second glass pane, so the cotton-covered polycarbonate sheet prepared earlier



FIGURE 25 Fragment with oak-leaf-and-flower patterns, cleaning on the glass table

FIGURE 26 Fragment with oak-leaf-and-flower patterns, realignment of the grain of the weave, shown on a glass table







FIGURE 27 Fragment with oak-leaf-and-flower patterns, during conservation stitching



FIGURE 28 Spearhead-shaped, acorn-topped fragments, after conservation

could be placed on to the reverse side. The glass and the prepared sheet were now turned over, so the glass was on top; the removal of the glass left the silk fragment placed on the crepline ready for stitching.

All parts of the fragments were now secured in position onto the crepline using entomological pins and small glass plates, necessary to ensure that no pieces would be moved by a chance flick of the hand or thread. Each fragment was sewn onto the stretched crepline surface with silk thread that had been dyed brown. The fragments were secured by stitching the leaf veins first, so that their centres would be kept in place. The contour threads were stitched next; the tears and edges of holes were then secured, as necessary, with tiny stitches that held the embroidery by their span.

Finally, following their conservation, the silk fragments (each held by its supporting crepline) were placed on a polycarbonate sheet covered in black jersey cotton, and their edges were sewn onto the back of this panel. The fragments with oak-leaf-and-flower patterns were sewn onto six separate panels, due to lack of certainty regarding their positions relative to one another.

The procedure for conservation stitching of the spearhead-shaped, acorn-topped fragments was the same as the one described for the flower patterned ones. In this instance the three fragments were stitched onto a single 600 x 800 mm sheet that had been prepared in advance, following discussions with museologists and the archaeologist. (Fig. 28) This of course does not signify any certainty that the original arrangement of the pieces has been found. Rather,

having been built on scholarship, the form achieved meets the need to exhibit and present the objects in an aesthetically pleasing manner.

## Summary and evaluation

Affinities between the silk fragments were discovered during investigations of their materials and manufacture at the Museum of Applied Arts. The ground material of the fragments is composed of unevenly woven silk taffeta, the warp and weft density is identical, and un-spun silk thread is used for the weft in both cases, while the applied embroidery used widely on medieval textiles can also be observed here. The slight difference in the depth at which they were found is no proof of their landing in the well at the same time, but the premise cannot be dismissed. It may even be argued that the Anjou Cloth and the silk fragments stood in close relation to one another. Since the exact dimensions of the original cloth cannot be ascertained, it is not out of the question that on its border it was decorated with plant ornamentation. Further research may provide answers to questions and surmises that arise.

A predilection for combining decorative motifs from heraldry and the use of stylized vegetal ornamentation is a trait typical of Hungarian Anjou objects.<sup>25</sup> These were discovered mainly upon medieval goldsmith's works, stone sculpture, miniatures and seals, with details repeated irrespective of the qualities of the object. These facts suggest that the objects emerged from the hands of the craftsmen working



FIGURE 29 Fragments with oak-leaf-and-flower patterns, after conservation



FIGURE 30 Seal of Charles Robert III, made by Petrus Simonis Gallicus in 1331

for the court under the same conditions.<sup>26</sup> Until now information about textiles at the Anjou court could be gleaned in the first place from the literature, the miniatures, the descriptions contained in medieval inventories and from seals.<sup>27</sup> Since there was no extant textile of the time, the Anjou Cloth is the first textile artefact to provide evidence for the use of heraldry as a widespread fashion.

Establishing whether the designer and producer of the Anjou Cloth was a master craftsmen of the city or a hired artisan, or establishing the environment in which this work was undertaken, is impossible due to lack of information. Cloths similar to the Anjou

Cloth are, however, portrayed in the background of a number of seals from the Anjou period. The double seal of Queen Elisabeth (1338)<sup>28</sup> and the royal seal of Lewis II the Great (1368)<sup>29</sup> show a very similar cloth, but the double seal of Charles Robert III, which is a major miniature sculpture not only on a Hungarian but also on a European scale,<sup>30</sup> shows the one closest to it in likeness. (Fig. 30) The seal was made by Petrus Simonis Gallicus in 1331 to replace the lost second seal of 1330. This is the only verified work of the Master from Siena. Charles Robert used the seal until the end of his life; he died on the 18th of November 1342.<sup>31</sup>

The similarity between the seal and the silk finds cannot be a coincidence. The goldsmith portrays a line of coats-of-arms on the drapery at the back of the throne that is identical to the Anjou Cloth except that the lambels are missing; even the number of coats-of-arms is the same. A characteristic plant motif, bending on opposite sides on the side of the cloth, is also portrayed; this shows extraordinary similitude to the other fragments recovered in the excavation.

Various workshops and artists of the time must have worked in the immediate surroundings of the king, and in close association with one another. There are examples of the same artist designing both metalwork and textiles, and even overseeing production.<sup>32</sup>

There is no way to prove that Petrus Simonis Gallicus designed the Anjou Cloth, or that he used

the cloth already in possession of the king for a background, without any data to this effect. For similar reasons, the place where the cloth may have been made cannot be established. In any case, the original view provided by a quilted cloth of appliqué embroidery is remarkably similar to a goldsmith's work with an embossed design and a punched background by virtue of the materials and techniques used in their creation.

## Endnotes

- 1 Bencze Z., 'Layers of the past', *Hungarian Museums* 8, no. 2002/2: 34-5.
- 2 Records of the site where the Anjou Cloth was found: K/4825, 1999.10.04. szp. 147 m, K/4923, 1999.10.08, szp. 147.7 m. Records of the site where the oak-leaf-and-flower patterned fragments and the spearhead-shaped, acorn-topped fragments were found: K/4882 and K/5016, 1999.10.07.12, szp. 146 m.
- 3 Participants in the preliminary cleaning were: Judit B. Perjés and Márta K. Bendefy, Judit Benda, Eszter Kovács and András Végh.
- 4 An Alcyl-dimethyl-benzil-ammonium-chloride disinfectant (Dodigen 226) that had been used to good effect since 1996. See Perjés J.B., 'Women's Shoes from the Crypt of the Dominican Church in Vác', *Conservation Around the Millennium*, Budapest, 2001: 100-1.
- 5 In environmental conditions of 18°C, 50-52 RH%.
- 6 Members of the Committee included: Dr. Sándor Bodó. Director; Dr. Katalin Dózsa, Vice Director; Dorotty Nyékhelyi, archeologist; Zoltán Bencze, Head of the medieval department; Dr. András Végh and Dr. Károly Magyar archaeologists; and Judit B. Perjés Head of the restoration department from the Budapest Historical Museum; Dr. Ernő Marosi, Professor and vice-chairman of the Hungarian Academy of Sciences; Dr. Walter Endrei, historian of textiles; Ágnes Timár-Balázs, Professor and textile chemist from the Hungarian National Museum; Dr. Zsuzsa Lovag Director; Katalin E. Nagy, textiles restorer from the Museum of Arts and Crafts; Dr. Csanád Bálint, Director of the Institute of Archaeology of the Hungarian National Academy of Sciences; Dr. Imre Holl and Katalin Gyürky-Holl, archaeologists.
- 7 Dr. Katalin Dózsa, Dorotty Nyékhelyi, Bencze Zoltán, Zsidy Paula (Budapest History Museum) Emőke László, Dr. Emese Pásztor, Márta Tóth, Anikó Pataki, Katalin E. Nagy (Museum of Applied Arts), Dr. Ágnes Timár-Balázs (Hun. National Mus.), Dr. Walter Endrei (Hun. Acad. Sciences) were present at the meeting on the 20<sup>th</sup> of September 2000.
- 8 Work began on 1st Nov. 2000, and was completed on the 28<sup>th</sup> of June 2001.
- 9 A Lambel (Turnierkragen, tonagallér) is a free floating swaddle-cloth whose lower side is mounted. It is usually placed at the head coat-of-arms. Its shape is reminiscent of a rake without a handle. (Oszkár Bárczy, *The handbook of Heraldry* [in Hungarian], Budapest, 1897: 93.)
- 10 Emőke László, *The Art of Embroidery* [in Hungarian: Hímzőművészet]. *Book of Antiquities* [in Hung.: Régiségek Könyve]. Ed Pál Voit. 312. Budapest, 1983.
- 11 Scheller, W. Robert, *Model-Book Drawings and the Practice of Artistic Transmission in the Middle Ages*. (ca. 900- ca. 1450) Translated by Michael Hoyle, Amsterdam University Press, (1995): 70.
- 12 Staniland, Kay: *Embroiderers*. Toronto, (1991): 30.
- 13 Philippa of Hainaut (b. ca.1314, d. Aug. 15, 1369) Queen Consort of Edward III, King of England.
- 14 See note 12: 28.
- 15 The Craftsman's Handbook '*Il Libro dell'Arte*', Cennino d'Andrea Cennini, Translated by Daniel V. Thomson, Jr. Dover Publications. JNC. New York (1960): 104-5. 'Take tailors' chalk, and make little pieces of it neatly, just as you do with charcoal; and put them into a goosefeather quill, of whatever size is required. Put a little stick into this quill, and draw lightly. Then fix with tempered white lead.'
- 16 Op. cit. p.116. 'Take a stretcher made as if it were a cloth-covered window, four feet long, two feet wide, with linen or heavy cloth nailed on the slats. When you want to paint your linen, roll up a quantity of four or fourteen yards all together, and lay the heading of this cloth over the stretcher. And take a block of either nut or pear, as long as it is good strong wood, and have it about the size of a tile or a brick; and have this block drawn upon hollowed out a good line deep; ... When you are going to work: Have a glove on your left hand; and first grind some vine-sprig black, ground very fine with water, then thoroughly dried either by sun or fire, then ground again, dry; and mix it with as much liquid varnish as may be required; and take up some of this black with a little trowel, and spread it out the palm of your hand, that is, on the glove ... And underneath the stretcher take a porringer in your right hand, and with the back, rub hard over the space occupied by the incised block.' Going on to describe the use of other colours apt for use with textiles.
- 17 Feldhaus, F.M.: *Die Technik der Vorzeit der Geschichtlichen Zeit und der Naturvölker*. München: 106, 1034.
- 18 Dr. Márta Járó and Miklósné Gál, of the ELTE TTK Minerals Department, carried out the examination of the material used for tracing. Procedure: SEM microanalysis of the surface of the sample. Results: The sample contained silicon, sulphur and calcium. Conclusions: none of the minerals, silver, tin or lead, which had been raised as possibilities earlier, were found on the sample.
- 19 Analysis undertaken by Dr. Ágnes Timár-Balázs, the colour tests were carried out at the Laboratory for Examination of Materials and Technologies at the Institut Royal du Patrimoine Artistique of Brussels enabling HPLC analysis. We would like to thank Dr. Jan Wouters, Head of Laboratories, and Ina Vanden Berghe, Textiles engineer, for carrying out the examinations.
- 20 The wet mud had shown an alkalinity of pH 9 when recorded.
- 21 Made of polystyrene.
- 22 2600 x 1300 mm Type: LTC 10/2 RS/10 of opal colour, and environmentally friendly material.
- 23 The transparent silk material was chosen so that the reverse side of the cloth was open to investigation in later stages.
- 24 The textile restorer of the Museum of Applied Arts, Anikó Pataki, also took part in the work of sewing restoration.
- 25 Marosi, E., 'Art in the fourteenth century at the Hungarian court, and in Central Europe'. *Art in the Age of Louis I, 1342-1382*. Budapest, 1982. (Ed.: Ernő Marosi, Melinda Tóth, Livia Varga.): 59.
- 26 Kovács, É., 'Anjou representation: Goldsmith's work', op. cit.: 94.
- 27 Dercsényi, D., *The Age of Louis the Great*, Budapest: 157-8.
- 28 Marosi, E.: op. cit.: 144.
- 29 Marosi, E.: op. cit.: 146.
- 30 Marosi, E.: op. cit.: 135.
- 31 Marosi, E.: op. cit.: 143
- 32 Christie. A. G. I., *English Medieval Embroidery*. Oxford, 1938: 18.

The crypt of the former Dominican Church, now known as the White Church, on the main square of Vác, served as a burial place for upper-class citizens and the clergy between 1731 and 1808. Walled up and later forgotten, the passage leading down to the crypt was only discovered during renovations at the church in the autumn of 1994. (Fig. 1) Due to the urgency of the rebuilding work, it was impossible to avoid emptying the crypt, which was tightly packed with coffins, and discontinuing the burial place. The Tragor Ignác Museum of Vác organized a team of museologists, conservators and anthropologists to bring the rescue excavation to a conclusion as soon as possible.<sup>1</sup> With the wealth of finds discovered in the crypt, it is to date the largest Hungarian burial crypt dating recent times to have undergone a comprehensive, scientific excavation, considering both the number of coffins found and the period of time over which the burials had occurred. Similar sets of contemporaneous finds have been deposited in museum collections from the Rosalia chapel of Eger in 1952 and the Saint Elisabeth church of Gyöngyös excavated in 1993.<sup>2</sup>

JUDIT B. PERJÉS, EMIL RÁDULY AND MÁRIA ÚJVÁRI

## Excavation of the crypt of the Dominican Church in Vác:

PRESERVING COFFINS, DRESS AND OTHER FUNERARY PARAPHERNALIA, 1731-1808

A unique opportunity presented itself to document every discernible detail of a practically undisturbed crypt, and to deposit the complete group of finds, which were to be removed from the burial place, in museums for further treatment. Coffins, sets of clothes and burial paraphernalia went to the collection of the Tragor Ignác Museum, while the remains of the circa 300 buried corpses were deposited in the Anthropological Collection of the Hungarian Natural History Museum. Close anthropological and pathological study of the mummified bodies provides information about the health, lifestyle and the acquired or inherited diseases present in eighteenth-century Hungarian society.<sup>3</sup>

Monks of the Dominican order settled in the city in 1699, and immediately set about construct-

ing their monastery and a small church with a crypt in the main square. Taking the cue from the monks' clothing, the popular term for the church became the 'church of the white ones'. Three years later, the monastery of Vác became a convent, and work on the extension of the church began; a new tower was raised, with a large crypt below with an entrance from outside. The church was widened between 1746 and 1755, which entailed the partial alteration of earlier existing crypts as well. The old cellar under the new side-chapel of the church was also used as a burial crypt from that point onwards.<sup>4</sup> (Figs. 2 and 3) Despite Royal decrees which regulated or rather forbade the use of communal crypts without dividing walls for general health considerations, the crypt in the Dominican church of Vác continued in use until



FIGURE 1 A detail of the crypt before excavation



FIGURE 2 The Dominican Church of Vác

1808. A few burials were also admitted in later years, until the early 1840s. Burial in the crypts of the holy orders became common practice during the seventeenth and eighteenth centuries in Central European cities.<sup>5</sup> Apart from monks and priests, this form of burial was an option for their family members, donors to the establishment and well-to-do citizens. It was an expression of the heightened religious propensity characteristic of the baroque period.

## Excavation

In the crypt of the Dominican church, coffins were placed tightly against one another, piled four or five rows high, with the feet usually pointing towards the wall. The bottom row was placed directly upon the brick paving. (Fig. 4) As more burials took place, an effort was made to place the larger, heavier coffins lower down, so that close relatives who had died at great intervals of time sometimes came to lie next to one another. There was such a great demand for burials in the crypt over the years that by 1808, the final year of its continuous use, even the corridors were jam-packed with coffins. The entrances to the crypts were permanently walled up at the end of the nineteenth century. This ensured that the burial place remained undisturbed and did not suffer any subsequent damage of note.

In the crypt under the tower, 152 coffins were excavated; 110 came from under the side-chapel, along with the remains of another 40 deceased in the bone repository. Some 166 persons were successfully identified by name with the aid of Hungarian,

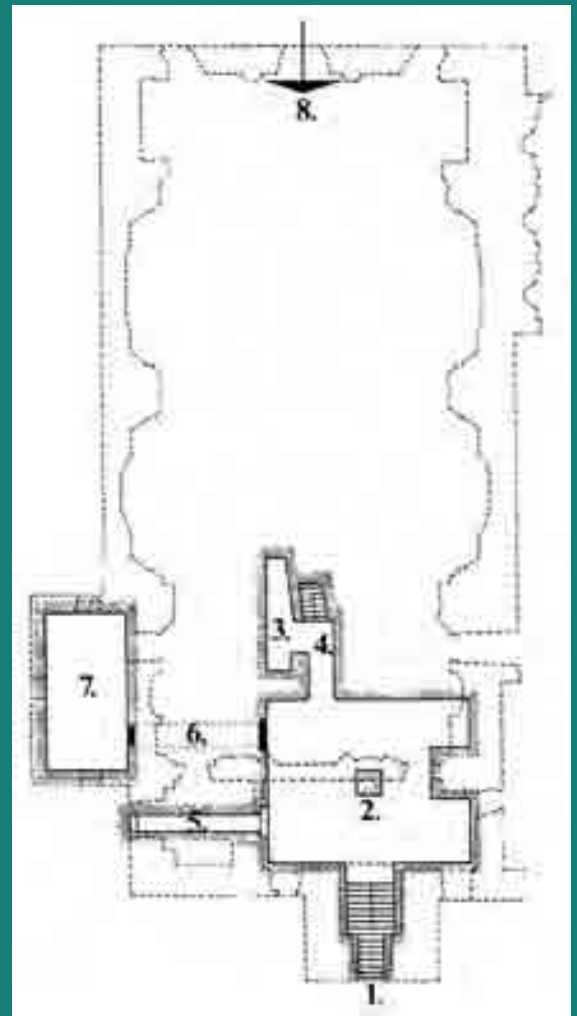

FIGURE 3 Plan of the church crypt



FIGURE 4 Detail of the crypt before excavation



FIGURE 5 Painted coffin before opening



FIGURE 6 Excavation of the coffin of a young woman, 1795

Latin or German inscriptions and records from the death register. Coffins without inscriptions were mostly those of monks, priests or children. The ideal microclimatic conditions of the crypt ensured that most of the corpses were either completely naturally mummified or part-mummified. The paraphernalia, clothes and funeral requisites were also preserved in large numbers and in good condition, often even having kept their original colour. (Figs. 5-10) In the cellar of the side-chapel, however, which was exposed to weather conditions and permeating dust, and in the ill-ventilated depths of the corridors or lower rows, the processes of decay took their toll upon the contents of the coffins.<sup>6</sup>

Apart from the urgent construction work, an important consideration in the choice of time for the excavation was that it had to be completed during the winter season. This time-frame ensured the least difference between temperature and moisture levels within the crypt and in the outside environment into which the objects would be lifted. Irreversible damage might have been caused to the organic finds had there been a sudden environmental change. This left only a few weeks for the work. Members of the team had to prepare for unfamiliar work, and the necessary materials and tools had to be procured within this time-frame. Special attention had to be paid to the acquisition of personal protective equipment and its proper use. Microbiological tests carried out repeatedly during the excavation did not reveal the presence of any organisms that might threaten the workers' health. (Figs. 7-8)

To help record observations in the greatest possible detail, a data sheet for documentation



FIGURE 7 Preliminary cleaning of finds during the excavation of the crypt

purposes was prepared in advance, and completed parallel to the ongoing excavation. The data sheet was modified on the basis of experience gathered in the first few days of the excavation. From there on, data was gathered according to a comprehensive set of reference points for each coffin. Colour photographs complemented written documentation. Work was carried out with the involvement of the least possible personnel and only the absolute minimum amount of light needed in order to protect the original condition of the crypt's microclimate.<sup>7</sup> In the final stage of work, a detailed film was also made to document the methods implemented.

The work of conservators and museologists inter-linked closely during this excavation. The initial cleaning and dusting of coffins preceded the photo session, since the thick layer of dust completely obliterated all ornamentation and inscriptions. Removal of the huge amounts of dust was done with a vacuum-cleaner and a soft brush, while a water-based solution of ethanol, ranging from 30% to 50% w/v depending on the condition of the coffin, was sprayed over it as an initial disinfectant. The excavation of the coffins took place layer by layer, and was accompanied by detailed photographic and written documentation. The packing of items of dress and burial paraphernalia followed after preliminary cleaning. Every object had to be freed from clinging dirt by means of a brush, low-power vacuum cleaning or tweezers. A variety of cloth remains were spread out on large wooden trays especially prepared for their temporary storage. (Fig. 11) Remains from each individual coffin were generally placed in a single tray or box during packing. Wherever possible,



FIGURE 8 Preliminary cleaning of the finds during the excavation of the crypt

FIGURE 9 Corpse of an older man, dressed in silver-laced dolman with open collar-ruffle

FIGURE 10 Excavation of the coffin of a middle-aged woman



FIGURE 11 Intermediary storage of material finds after excavation

these were also sorted by material to facilitate conservation treatment. A gauze-like, acid-proof foil was used for packing. This was suitable for filling gaps in and between objects, as well as for stuffing fragile objects (such as silk clothing, shoes with leather or cloth uppers and bonnets) so they would not be crushed. Any objects that seemed moist were either packed with an antiseptic material, or their packing material was impregnated with disinfectant.<sup>8</sup> An immediate, on-site reinforcement of paper objects, especially devotional pictures, was necessary to avoid the continued disintegration of these small pieces until their proper restoration could be managed.<sup>9</sup> Objects thus prepared and packed for transportation stayed in the crypt for another few days, and were then taken to a storage space with similar temperature and humidity, for an initial safekeeping period of several months.

## The finds

As a result of the excavation, around 1,500 pieces were added to the collection of the Vác Museum. Among them, one might especially mention 169 different, highly ornamented coffins, 150 rosaries and 60 crucifixes, also of great variety. The main part of the collection is made up of pieces of apparel or their fragments, along with a mass of burial paraphernalia made from textiles.

Sixteenth- and seventeenth-century Hungarian historical sources often mention coffins coated in

canvas or silk and studded with decorative nails. Coffins dating to the 1790s, such as these, can also be found in the crypt of Vác, but only in limited numbers. (Fig. 12) The cloth-covered coffins were mostly of a dark colour for adults, and green or white for children. Masters of the local carpenters' guild made them. They, or their relatives, also carried out painting and ornamental work, with attention to customer needs and the dictates of tradition. A gradual modification in the ground colour and the character of the ornamentation can be observed over the hundred years of the crypt's usage. Meanwhile citizens arrived in Vác from different regions of the country; of different national backgrounds, these newcomers also contributed to the variety in colour and ornamental motifs used on coffins buried at the same point of time. Styles imported by settlers of German, Austrian and Czech descent had a determinant role.

Until the 1760s, a green colouring, to be followed later by blue, marked children's coffins. (Figs. 13, 15) The coffins of adult married men or women cannot be distinguished on the basis of colour or ornamentation. The earliest ones were painted with wood dye, and their ornamentation was also simple, with black foliage and stylized tulips or floral designs. A coloured ground becomes popular only from the 1750s. First grey and later yellow becomes the usual colour, to be followed by brown at the end of the century. The decorative motifs are also of an increasing variety, and of greater naturalism, with the simultaneous use of a diverse array of colours characteristic of the latest coffin made. (Figs. 13-4) A crucifix is found on every coffin, with the possible accompaniment of other symbols indicating a particular branch of Christianity. Hand and feet stigmata appear at first; complete portrayals of Christ become frequent from the middle of the century, some of them worked by skilled artistic hands. Inscriptions (*Memento Mori*, *Venit Hora*) and emblems (hour-glass, broken candle, skull, spade and hoe, owl) on the coffins refer to death and the inescapable fact of impermanence, and reflect the religious worldview of the baroque period. Yet this is accompanied by a rich diversity of colour; a variety of floral patterns, ornamental foliage and wreaths, as well as the harmony of composition, which testify to the spirit and good faith of the relatives of the deceased. (Figs. 16 and 28)

Inscriptions found on the coffins also afford a chance to observe the situation at that time with regard to ethnic background and language use. The dominance of Latin as the literary language of the time asserts itself in the language of choice for the inscriptions as well; inscriptions in Hungarian were particularly scarce, really coming into play only from





FIGURE 12 The crypt with painted and covered coffins in their original position

FIGURE 13 Painted coffin of a child, 1751

FIGURE 14 Painted coffin, 1808



FIGURE 15 Painted coffin of a child, 1790s

FIGURE 16 Exhibition of the works of the restoration course (summer 1995)

the first decade of the eighteenth century. Many citizens of the city were of German background, a fact reflected in the number of coffins inscribed in German, as well as the rolls of names of people buried in the crypt. Mass migration in the eighteenth century was directed into the regions that had been depopulated by the Turkish wars so that cultural factors and traditions also led to a mingling of customs.

The great number of finds made the involvement of workers from other museums imperative, and a wide-scale co-operation of experts evolved. An example of this was the organization of ‘summer camps for conservator volunteers’ in 1995. Two more followed over the years. The temporary exhibition, organized as early as 1995 by the Museum of Vác to draw the public’s attention to the significance of the finds, was a direct result of this work. (Fig. 16)

Burial paraphernalia found in the coffins provide evidence for a profound religious feeling in eighteenth-century society. A rosary with a crucifix was placed in the hand of every single deceased person. (Fig. 17) That devotional societies operated in this section of the town at the time is indicated by the

scapular devotional pictures (symbols of affiliation to a religious order, often consisting of two small rectangles of woollen cloth, joined by tapes passing over the shoulders) and waist-cords. Sources first mention the Society of the Rosary in 1720. The promulgation of the use of the rosary is traditionally attributed to the Dominican order. Tokens, relics, and wooden or mother-of-pearl inlaid crucifixes from Jerusalem, medallions brought from pilgrimages to the Holy Land, from shrines of the Virgin Mary and other places of pilgrimage are typical of the period. Most crosses, crucifixes and other objects of piety would have been in use for a long time before burial. Yet some of them, like the wax crucifix, should be considered a funerary requisite. (Figs 18-19) The variety and fine execution of the objects are proof of the high standards of workmanship reached in European mass production workshops.

Beyond the burial and funerary customs of the eighteenth century, the excavation also made it possible to see the dress of the middle classes. Most of those buried were put to their final rest in their own richest attire. Women and children were always laid to rest with a bonnet, men usually with bare heads, sometimes with a knitted nightcap, and rarely with a hat. (Fig. 9) Young girls, women and children were decked out in ribbons, flowers, both natural and artificial, in a girl's Hungarian head-dress and wreaths in even greater abundance. (Fig. 20) Even youths wear small wreaths, usually woven of a rosemary branch, placed on the head. Women are dressed in a variety of clothes: shirts and aprons made of fine woven cambric; skirts are of woven or colourfully printed material; and, kerchiefs, blouses and ribbons made of silk. Men are dressed in close-fitting tunics and broadcloth trousers with ornamental



FIGURE 17 Rosary with cross, 1772

FIGURE 18 Wax crucifix, 1774

FIGURE 19 Wax crucifix, 1841

FIGURE 20 Conserved head-dress of a girl, 1784



strings and buttons, or a long gown fastened at the front with hooks and eyes or buttons.

Wool stockings were pulled on to the corpses in most cases, but in rare instances we find leather foot-cloths, boots and even shoes in the case of priests. Leather foot-cloths were typically Hungarian footwear, with short legs reaching above the ankles, stitched from three or more pieces of soft leather, laced on the inner side and without heels. Such footwear was widely worn in the sixteenth and seventeenth centuries. An iron-heeled shoe, called a slipper because of its low sides and heel, also went with it.<sup>10</sup> (Fig. 21) According to the records, the leather foot-cloth was no longer everyday wear in the eighteenth century. It was primarily a piece of funeral costume.<sup>11</sup> The colourful and ornamented women's and children's shoes always followed the Western European fashion of the day, with uppers made of leather or cloth. The fronts of the shoes were decorated with copper spangles and pleated silk

ruffles. The slippers were similar to ladies' shoes in both shape and style.<sup>12</sup> (Figs. 22-4)

Many were buried in a funeral tunic, a cloth that symbolized full apparel, and as a consequence became a burial accessory. The tunic's size and pattern were in fact prescribed by the Hungarian tailors' guild of Vác in 1961.<sup>13</sup> In any case, grave clothes differed from everyday dress to a significant degree, as they represented festive wear. Due to difficulties with clothing corpses, the attire of the deceased would often be left incomplete. This explains the fact that shoes were often missing, or certain pieces of cloth were just laid over the body.

Thick layers of wood shavings were strewn under the burial sheet, and shavings filled the funeral pillow as well. A wide border of bobbin lace sometimes decorated the edge of the funeral sheet near the head of the deceased. Before the coffin was shut, the corpse was often covered with a funeral shroud of silk, cotton, wool or linen. The edge of the



CLOCKWISE FROM UPPER LEFT

FIGURE 21 Restored leather leggings, 1764

FIGURE 22 Pair of lady's shoes prior to conservation, 1808

FIGURE 23 Shoes of a child after conservation, 1801

FIGURE 24 Shoes of a child after conservation, 1805





FIGURE 25 Restoration of painted coffins in the exhibition hall of the museum

FIGURE 26 Conservation of a painted coffin

FIGURE 27 Detail of a coffin from 1791, after conservation

shroud that remained outside the closed coffin was decorated, e.g. with rosettes.

The extant pieces of clothing in good condition make up forty sets of what may be considered full costumes. These are of special significance because until now sources for the study of the history of dress in the eighteenth century have depended on pictures and archival data. There are very few surviving items of dress, and these are mostly of aristocratic court fashion. Portrayals also only deal with over-clothes. It is easy to suspect that these are idealized, at least in part. Major parts of the substantial archival material available on the subject are difficult to interpret without knowledge of the objects themselves. The finds from the crypt, in good condition and accompanied by the investigations carried out during the excavation, ensure a wealth and detail of information that may be likened to recent ethnographic collections of data. These not only deal with particular items of dress, but also with entire sets of clothes: from headgear to footwear, outer clothes to underwear.

The varied material of the finds provided an opportunity for students to join the work during their conservation training. Participation of students from the Object Conservation Department of the Hungarian Academy of Fine Arts in the rescue work was made possible either through group exercises on site, or in the form of individual examination pieces. (Fig. 25)

## Cleaning and conservation

### The coffins

The layer of paint on most painted coffins had crumbled and become powdery. Removal of a thick layer of dust and other dirt had to be done mechanically, before proceeding to fix the paint. A polyvinylbutyral or polyvinylbutyrate solution (5%) in ethanol worked best as fixative coating. (Figs. 26 and 28)

The cloth-covered coffins demanded a special conservation method. It was not possible to carry out their cleaning, conservation and restoration by types of material because the coffins would have suffered further damage through the disassembly that would have been required, and even destruction of the cloth, which was already in a ragged and decayed state. There was a need to devise a way of going about handling the object that would circumvent the removal of the nails and textiles from the coffin's pine boards, which were themselves in fine condition.<sup>14</sup>

A separate work plan was prepared for conservation of the 75 cloth-covered coffins with overhanging drapery. This specified the coffins that were definitely in need of conservation, the most characteristic pieces



FIGURE 28 Painted coffin with inscription, 1766

in the class of object dealt with here. A schedule for their cleaning, conservation and storage was prepared. An investigation into the condition of each object was made, as the material and condition of the object were considered to be the most decisive factors in determining the conservation treatment. Cleaning followed by hand, using brushes and the suction of a vacuum cleaner applied with maximum care and through a fine net covering. Then the overhanging drapery was laid out and the dust was removed by similar means. The cleaning of the textile cover was carried out with an upholstery vacuum cleaner and a cleaning solution made with softened water. Mechanical cleaning of the copper-topped nails came next. The surrounding cloth was protected so it would neither be damaged nor smeared with the corrosion products being removed. To help legibility of inscriptions, the missing nails were replaced with nails prepared according to the original manufacturing technology.<sup>15</sup> Where possible, the conservation and restoration of the textile itself took place with conservation stitching. In each case of repair to overhanging drapery, the treatment was successful, for these could be laid out flat. Crepeline dyed to a suitable colour was used as a support material, and linen canvas of an identical weave was used for infilling. Silk thread was used to attach the support, with a laid stitch.

Filling losses in the material nailed to the boards proved to be a greater challenge. In the case of silk materials, the fills were usually successfully applied by conservation stitching. The linen canvas had by its decay become too weak for stitching. In such instances the areas missing between the nails had to be in-filled by cutting out the new material (dyed



FIGURE 29 Reconstruction of the crypt in the exhibition

the right colour), with extra material left around the edge. A pH neutral water-based dispersive adhesive was spread on the edges of the insert, which was then stuck on the wood under the original material with the warp of the cloth running the same direction. The loose threads of the original material could then be attached with a minimum application of adhesive.<sup>16</sup> (Fig. 27)

## The textiles

The textiles retained their original colours in all but a few cases. Textiles prepared from vegetable fibres were in rather good condition compared to those made of fibres of animal origin.

The germicidal cleaning of clothes and other textile articles began a few weeks after excavation, with fears that the mould spores on them, and microbes breeding within the organic remains, would activate on contact with a changed environment, and trigger the process of decay.<sup>17</sup> While the pieces of cloth that had become hardened due to body-fluids were being moistened through a mesh, most of the remains of putrefaction and larvae passed out with the polluted water. The cloths were dried on polystyrene sheets covered in polypropylene sheeting.

Some parts of the garments, however, could not be exposed to wet cleaning. Their material was so complex and fine, and their condition so precarious,

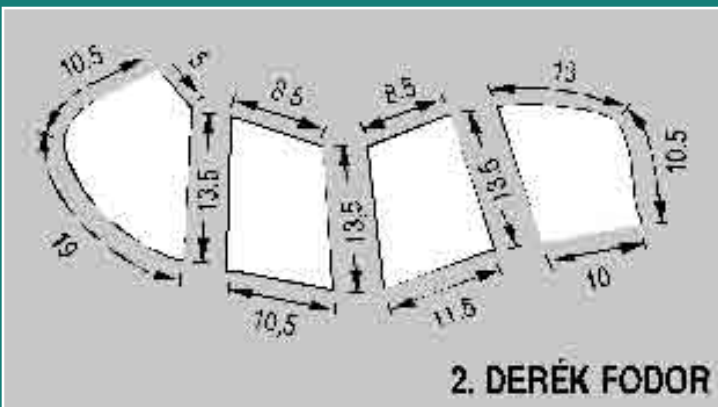
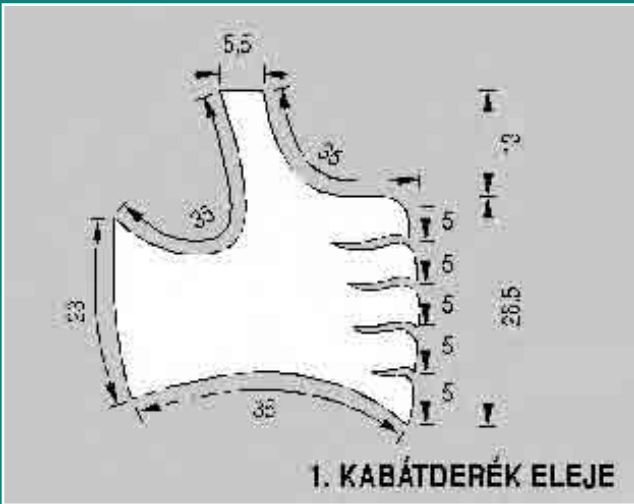

FIGURE 30 The silk bodice of Barbara Kiss from 1780, after conservation

FIGURE 31 Pattern for the 1780 bodice

FIGURE 32 Pattern for the side panels of the 1780 bodice

FIGURE 33 Pattern for the back panel of the 1780 bodice

that this had to be avoided. Examples included children's and women's bonnets, where the cleaning was carried out mechanically, using brushes. These bonnets were lined (padded) with acid-free gauze permeated with germicides, and they maintained the condition in which they were found for many years. The bonnets were usually made with quilted cotton (piqué), silk or cambric, decorated with lace edges and silk ribbons or tulle frills.

The restoration of the textiles took place with concern for the interest shown in them, and the requirements set by their exhibition in both Hungary and elsewhere. Apart from a few dress accessories and some textile funeral requisites, a woman's complete costume was restored. In addition, the reconstruction of a woman's costume, and the grave-clothes of a man and a child, was also completed. The large quantity of finds meant that all-inclusive conservation and restoration was not possible. The finds were made available for research and some of the costumes were surveyed by professional conservators. Thus the patterns for the clothes could be processed through a computer programme.<sup>18</sup> As a result the exact description, size and pattern of some costumes was made available. Using these aids, authentic reproductions can be produced for exhibition purposes. (Figs. 30-3)

### Leather objects

The number of leather articles of clothing is not significant in comparison to those of textile. Their conservation and restoration went ahead at a comparatively quicker pace for this very reason.<sup>19</sup> (Fig. 34) Cleaning and disinfecting of alum-tawed leather, sensitive to water, was carried out with an emulsion of perchloroethane and sulphated neatsfoot oil in the ratio of 3:1. Water, to which a non-ionic detergent





FIGURE 34 Men's boots, 1806, after conservation

FIGURE 35 Pair of leggings with knee-guards, after conservation

had been added, was used to clean the vegetable tanned leather.<sup>20</sup> Depending on the condition of the objects a water-based solution of polyhydric alcohols (glycerol, sorbitol, PEG 600), and various mixtures of sulphated neatsfoot oil -lanolin, cetyl-alcohol and t-Butanol were used. After drying to shape, the stitches that had weakened or broken were re-stitched, and missing parts replaced with identical leather glued on.<sup>21</sup> Crepline supporting material and modified cellulose glue was used with sewing conservation when textile-topped shoes were being 'completed'. Metal ornamentation, buckles, and copper spangles were best cleaned mechanically. Attention had to be paid to leaving signs of wear untouched. Shoe-trees were prepared for the storage of all treated shoes, so their stability would be ensured over time.<sup>22</sup>

The restoration work on a pair of gaiters with knee-guards, whose mode of manufacture was previously unknown to the team, required a special solution. This is its first occurrence in sources on Hungarian costume history of the eighteenth century.<sup>23</sup> The gaiters were found in the bone repository in poor condition: in pieces, torn and with areas of loss. After conservation in a solution of glycerol and water, the gaiters were dried slowly at room temperature, between sheets of blotting paper. Before beginning restoration, analogies had to be found for the reconstruction, so it would take place with full awareness of its original form and manufacturing methods. The conservator first glued into place the parts that had come apart in sheets, using thin glue. The weakened or torn parts were secured by gluing in vegetable tanned calfskin. Finally the

segments were sewn together along the holes left by the original stitches. (Fig. 35)

A permanent exhibition under the title 'Memento Mori' opened in the summer of 1998. It was set in three halls of a fourteenth-century cellar on the main square of Vác and in the vicinity of the Dominican church, which had been the excavation site. The exhibition provides an overall view of the decoration of the coffins and the funeral accessories. The most typical costumes and burial customs are also presented. (Figs. 29 and 36)



FIGURE 36 Memento Mori Exhibition. Finds from the crypt of the White Friars Church of Vác

## Endnotes

- 1 The leaders of the museology work team were Emil Ráduly (Ethnographic Museum, Budapest) and Márta Zomborka (Tragor Ignác Museum, Vác) and in conservation, Judit B. Perjés (Budapest Historical Museum) and Mária Újvári (Tragor Ignác Museum, Vác), with Dr. Susa Éva as expert advisor in anthropology. A detailed description of the circumstances of the excavation is available in: Zomborka, Márta: Az előzmények és a feltárás [The Precedents and the Excavation]. *Magyar Múzeumok* 1996/1: 3-7, and Ráduly, Emil: A váci fehérek temploma kriptafeltárása [The Excavation of the Crypt of the Premonstratensian church of Vác]. *Műtárgyvédelem* 1997/26: 21-27. Work continued through November 1994 to early February 1995; another section of the crypt (discovered later) was excavated in May 1995.
- 2 Ember, V. Mária, Az egri Rozália-kápolna textiljei [Textiles from the Ralia chapel of Eger]. *Folia Archaeologica* 9 (1957); 219-236. Ember, V. Mária, Az Egri Rozália-kápolna cipői. *Folia Archaeologica* 13 (1961): 251-268. B. Gál, Edit, Szilcz, Ágnes and Deák, Endre, Életmód és temetkezési szokások Gyöngyösön a 18. század végén és 19. század elején [Life style and burial rights in Gyöngyös in late 18<sup>th</sup> and early 19<sup>th</sup> c.]. *Mátrai Tanulmányok* 1995: 29-49.
- 3 Susa, Éva, Pap, Ildikó and Józsa, László: Váci múmiák antropológiai vizsgálata [An anthropological investigation of the mummies of Vác]. *Magyar Múzeumok* (II. évf.) 1996/1, pp. 14-16. Pap, I., Susa, É., Józsa, L.: Mummies from the 18<sup>th</sup>-19<sup>th</sup> Century Dominican Church of Vác, Hungary. *Acta Biologica Szegediensis*, 42 (1997): 107-12. Szikossy, I., Bernert, Zs., Pap, I.: Anthropological investigation of the 18<sup>th</sup>-19<sup>th</sup> Century ossuary of the Dominican Church at Vác, Hungary. *Acta Biol.*, 42 (1997): 145-50.
- 4 Karczú, Antal Arzén: *Vác város története*, 8. köt. [History of the city of Vác, vol. 8]. (1887): 139.
- 5 Johnova, Helena: Barokk koporsók díszítményei a cseh területen [Ornamental work on Hungarian coffins in the Czech Republic]. *Magyar Múzeumok* (II. évf.) 1996/2: 64. Mais, Adolf: Die Gruftbestattungen zu St. Michael in Wien, *Kultur und Volk*, V., Wien (1954): 245-72.
- 6 The tests and culture of samples were carried out at the National Centre of Traumatology.
- 7 According to the technical examinations conducted by the Department of Meteorology at the Eötvös Lóránd Academy of Sciences, the temperature in the crypt was 8-11°C, air pressure was 109 hPa, and RH ranged between 85-90%.
- 8 Substances used for disinfection and killing of spores: Sterogenol (ethanol and water solution of 0.02-0.05% with cetylpyridinium-bromide) and Preventol CMK (p-Chloro-m-Cresol 0.05-0.1% in Ethanol).
- 9 Mounting onto rice-paper with an adhesive solution of water and 5% ethanol with Klucel M (hydroxy-propyl cellulose).
- 10 *Magyar Művelődéstörténet III.* (ed.: Sándor Domanovszky): 365-372, ill. 24. Radvánszky, Béla: *Magyar családélet és háztartás a XVI-XVII. században* [The Hungarian Home in the 16<sup>th</sup> and 17<sup>th</sup> c.]. Budapest (1986): 117, ill.
- 11 Schramm, Ferenc: Vác népének szellemi kultúrája 1686 és 1848 között [The cultural spirit of the people of Vác between 1686 and 1848]. *Levéltári Szemle* (1963/3): 581-627, 649.
- 12 Perjés, B. J.: Women's Shoes from the Crypt of the Dominican Church in Vác. *Conservation Around the Millennium*. Hungarian National Museum (2001): 95-105.
- 13 Duray, Kálmán: A váci céhek [The Guilds of Vác]. Vác (1912): 140.
- 14 Kovács, Petronella: A váci Fehérek templomában feltárt festett és textillel bevont koporsók restaurálása. [Conservation of the painted and cloth-covered coffins found at the Church of the White Friars in Vác] *Műtárgyvédelem* 26 (1997): 29-37.
- 15 Coating: an equal mixture of Paraloid B72 3% of acetone-toluene.
- 16 The implementation of this method took place in the practical class of the Object Restoration Department of the Hungarian Academy of Fine Arts under the supervision of Professor Györk Mátéfy.
- 17 Disinfectant: a soft water solution with 1% Dodigen 226 (alkyl dimethyl benzyl ammonium chloride).
- 18 The survey was carried out by Katalin E. Nagy (Museum of Applied Arts) and Enikő Sipos (Hungarian National Museum).
- 19 The students of the Object Restoration Department of the Hungarian Academy of Fine Arts (leather specialization) conserved 8 pairs of footwear under the supervision of Judit B. Perjés and Márta Kissné Bendefy, while one was conserved for the exhibition *Europalia Hungaria* of 1999 in Brussels: Perjés, J.B. Women's Shoes from the Crypt of the Dominican Church in Vác. *Conservation Around the Millennium*. Hungarian National Museum (2001): 95-105.
- 20 The disinfectant was Preventol CMK ((p-Chloro-m-Cresol) dissolved in i-Propanol, or Dodigen 226 (alkyl dimethyl benzyl ammonium chloride) dissolved in water.
- 21 Adhesive application was carried out using a mixture of starch and Planatol Superior BB (polyvinylacetate dispersion) in the case of leather, and Klucel M (hydroxypropyl-cellulose) adhesive in the case of textiles.
- 22 Various shapes can be made out of polyethylene plastic sheets 5-20 mm thick.
- 23 Kissné Bendefy, Márta: Restoration of a pair of 18<sup>th</sup> Century Leather Gaiters. *Conservation Around the Millennium*. Budapest (2001): 85-94.



The conservation of two medieval parchment codices is described. Both codices belong to the Oriental Collections of the Hungarian Academy of Sciences and come from the Kaufmann Bequest. The invaluable library of Dávid Kaufmann (1852-1899), a professor at the Jewish College of Theology in Buda, was donated to the MTA (Hungarian Academy of Sciences) Library by his mother upon his death. The gift contains, among other rarities, 1,066 books printed in Hebrew, 9 items of incunabula and 591 manuscripts.

ILDIKÓ BEÖTHYÉ KOZOCSA

# The conservation of two medieval parchment codices

## The Kaufmann Haggadah

One of the most valuable manuscripts is the Kaufmann Haggadah (ref. A 422).<sup>1</sup> Haggadah means ‘teaching’, and the manuscript contains hermeneutics by ancient rabbis. It was one of the ceremonial readings of the Jewish Passover. It was first found in a separate volume in the eighth century. Jewish artists took pleasure in making illustrations for the book, several of which can be found in public and private libraries all over the world. Up to now three facsimiles have been published: the Haggadah of Sarajevo, which came into the possession of the National Museum of Sarajevo in 1894 from a Spanish Jewish family. The second, the so-called Haggadah of Darmstadt, is in the Darmstadt Library, and the third is the Kaufmann Haggadah. There are several theories about its origins; it is supposed to be of either Spanish or of Southern Italian origin. Professor Sándor Scheiber is of the opinion that the manuscript is Spanish but he acknowledges some Italian or French influences. In

his view the volumes date from the third quarter of the fourteenth century.<sup>2</sup>

The illustrations of this Haggadah fall into three categories: scenes from the Bible, historical scenes, and depictions of the Seder rituals. The biblical scenes, quite unusually, were arranged in an incorrect order. Some are at the beginning and some at the end of the manuscript and they follow from left to right. Professor Scheiber argues that the sheets were assembled in an incorrect order during rebinding. This fact would explain why the full-page biblical miniatures were put at the end. Professor Scheiber assumes that the artist must have been strongly influenced by Christianity. The large number of bare-headed figures, the shroud carried by women, and people kneeling at prayer support this assumption. Kaufmann noticed the influence of Northern Italian artists in the illustrations, e.g. Italian Gothic features in the architecture, while the rich ornamentation of the background reveals French influence.

## Production technology

The manuscript was made of unusually thick parchment including a few thinner leaves. The results of the ink and dye analysis carried out before conservation show that the ink was lamp-black in a gum-arabic medium.<sup>3</sup> The same diluted ink was used to sketch the scenes, to draw the geometrical patterns, and to edge the gold letters.

After drawing an unusually thick - about 2 mm - gluey coating was applied which was given its ivory colour by using microscopic quantities of azurite, ochre red and lamp-black. The sheets of gold-leaf were glued to it with egg-white, and were then polished and trimmed. The following step was to tint the background, apply the colours; finally the gold letters were edged in black and decorated with white lead dots. Bole was used under the gilding. The pigments used are: lead white, minium, malachite, verdigris (copper green), red ochre, lamp-black. The colours claret, pink and violet blue were all achieved with organic dyes. The medium was a mixture of

gum-arabic and egg-white. The claret folium and the green malachite have come through to the verso of the parchment.

## Condition report

When it arrived at the restorer's workshop at the National Széchényi Library, the manuscript had been badly damaged.<sup>4</sup> According to Miksa Weiss' earlier description its leaves had been mangled and trimmed.<sup>5</sup> The trimming must have taken place before 1898 during the rebinding of the book in order to repair the imperfections on the margins. The codex was probably bound in the simple parchment cover on that occasion. As a consequence of rough trimming the marginal ornaments were mangled and some figures were cut in half. The size of missing parts can only be guessed at: the loss probably amounts to about 1.5-2 mm.

The bottom corners were badly damaged, probably due to intensive use. There the edges of the parchment have become brownish and quite brittle. There were greasy stains caused by fingerprints and



FIGURE 1 One of the damaged leaves of the A 422 codex



FIGURE 2 The damaged miniature and parchment of codex A 422



FIGURE 3 The damaged miniature of codex A 422 after conservation

evidence of damp patches was found. The verso of the full-page size illustrations was left empty by the miniaturist. Some of these pages were stained by the glue that had run down the spine during rebinding. The sheets were stitched onto six narrow parchment strips by the binder who was repairing the book; then they were reeved through the parchment cover in the usual way to fasten the body to the paper-lined cover.

The torn leaves were probably repaired with self-adhesive tape in the past few years or decades. The adhesive in such tapes gradually becomes yellow and dissolves a text written in ink. Fortunately in this case it did not cause irreparable damage as it did not cover any texts or miniatures but the parchment underneath became a darker yellow. The parchment became stiff, slightly wavy and rather dry. Leaf no.16 was deformed and crumpled. Its parchment must have been defective but still there was a text written on it although there are no miniatures or ornaments on it. Tiny holes were caused by insects.

The ink of the text was hardly faded or damaged but the dyes of the miniatures and most of the marginal ornaments were rather faded, cracked or had come off. Some of the gilt letters had come off due to the too-thick under-coat, and some of the gilding was missing in these places. A number of these gaps were filled and coated in golden-brown (bronze?) dye.

### Conservation

During restoration it turned out that the chipped, faded colours, mostly red and blue, had been repainted. The shades and the solubility of these dyes are rather different from the original pigments: methanol would not dissolve either the ink or the original dye but to a small extent it gradually, in the course of time, dissolved the retouched blue dye, and in some cases the claret as well. After the solubility tests, the body of the book was removed from its soft parchment cover. The leaves were re-numbered in order to arrange them in the correct order; then the manuscript was dismantled into its constituent sheets. The dust-covered, stained surfaces of the parchment were gently cleaned with powdered india rubber avoiding the coloured areas; the greasy stains were removed with an electric eraser. This was followed by complete removal of the self-adhesive tapes by applying acetone wipes. Cracked gilding was coated in several layers with an egg-white emulsion developed by the restorers themselves, using paintbrushes under a magnifying glass. The components of this emulsion are similar to that of the ground used in gilding.<sup>6</sup> It penetrates into the cracks and fixes loose particles.

The loose layers of pigments had to be fixed, the wavy leaves had to be straightened in order to eliminate the differences in the surface tension caused by the waviness which may have led to the cracking and peeling of the pigments. At the same time we wanted to soften and loosen the hard, stiff and dry parchment leaves via procedures that were both delicate and of short duration. The most important aspect was to achieve maximum effectiveness without doing any harm. A plan was drawn up to realize all three objectives in one single process. As the ink and dyes of the manuscript are extremely sensitive to water, they had to be protected from any moisture. The procedure was to leave the manuscript in the air-conditioned climate of the workshop for a few weeks; then the leaves were immersed in a solution of alcohol and Klucel<sup>7</sup> for 10-15 minutes under permanent observation. Each leaf was mounted on protective paper sheets before immersion, and then dried under slight pressure between Bondina sheets.<sup>8</sup> While changing the Bondina and the felt

sheets, pressure was gradually increased by means of weights, making the leaves flatten out and dry in a gradual process. The loose layers of pigments were fixed by the invisible, gentle dispersion of Klucel. The once stiff and hard leaves became more flexible, elastic and softer to touch.

The torn parts of the letters were pasted and covered with goldbeater's membrane.<sup>9</sup> The larger, missing parts of the corners were replaced by writing parchment. The minor gaps and punctures caused by insects were filled in with a semi-moist parchment pulp<sup>10</sup>. The conservation process was completed with replacement of the mangled parts and complete drying of the manuscript for several weeks. The codices were gathered on parchment strips with a flyleaf and then bound in a semi-hard parchment cover. The covers were tied together with cords to prevent the 'motion' of the material; finally the manuscript was put into a protective cardboard case.

## A Hebrew Prayer-Book

The Hebrew manuscript (ref. A 384) was also part of the Kaufmann Bequest.<sup>11</sup> According to the Weiss catalogue it was written in ca.1320 in South Germany. It was a prayer-book (*mahzor* in Hebrew) especially made for the German rituals of the major

Jewish holidays. Originally it consisted of three volumes: the first is in the Oriental Collections, the second is in the British Library, and the third is in the Bodleian in Oxford.

### Condition report

The text-block's most recent cover is of simple light brown leather and is in relatively good condition. The repairer had saw-cut the sheets at three points of the spine and had stitched them onto a hemp cord. The ink of the manuscript is lampblack in a good state, but the mineral and vegetal colours of the miniatures and illustrations had been smudged or come through in certain spots. Gilding is cracked, imperfect, or peeled off. The manuscript had probably been exposed to moisture at the spine before rebinding so it became mouldy.<sup>12</sup> The first twenty-five leaves had been badly damaged and mangled at the head; there were dark purple stains around the middle of the leaves where there are gaps and holes in the text as well. Thick paper and parchment strips from fragmented manuscripts had been glued to cover the gaps, probably as part of the rebinding. The script was partly obscured by these patches. The 'bites' of drugstore beetle larvae can be seen on the leaves.<sup>13</sup> The centre of the decayed sheets had been fastened with over-thick strips of paper which made the parchment crumpled.

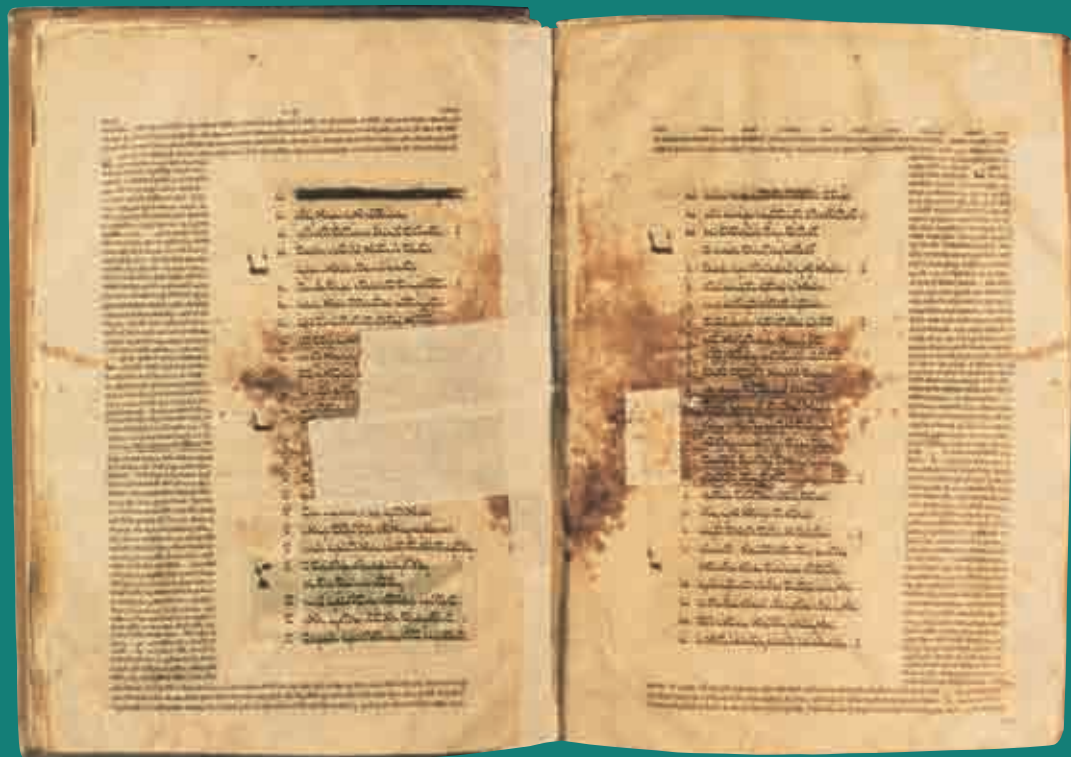

FIGURE 4  
A damaged leaf  
with the paper  
strips glued to the  
parchment of codex  
A 384



FIGURE 5  
Manuscript A 384  
after conservation

After stitching, the binder coated the spine with a thick layer of bone glue.

### Conservation

Before conservation the text-block was removed from the cover. The thick coat of glue was softened and removed from the spine with a methyl-cellulose solution; then the manuscript was dismantled into sections. The paper and parchment strips used to cover imperfections were removed. Disinfectant<sup>14</sup> was sprayed onto each leaf separately. The disinfectant provides preventive care against later contamination. Only the waviest and most deformed sheets (sixteen in all) were immersed in a solution of methanol and Klucel (as mentioned earlier in the description of the first codex). After surface-cleaning (including meticulous cleaning with powdered rubber) the cracks in the real gold ornaments were fixed with egg-white emulsion. The mangled leaves were completed with new sheets made with strips of parchment and goldbeater's membrane, since many leaves had only been held together by a thick layer of glue or strips of paper at the spine.

The missing parts of the mangled, weakened parchment (damaged by micro-organisms) were

infilled using the restorers' own method of 'parchment casting', which had been successfully applied in conservation for many years.<sup>15</sup> The parchment pulp (that is, parchment and swollen cellulose fibre made from Japanese paper with the addition of organic glue and disinfectant) is mixed in a solution of water and ethanol. The parchment is cast on a vacuum table made from perforated acrylic sheet (Perspex/Plexiglass). A polyamide sieve is put on the table under a finer silk sieve and after preparatory procedures the manuscript is laid over the sieves. It is moistened with a spray of ethanol and the air-exhaust process is started in order to smooth out the leaf on the perforated sheet. The pulp is poured onto the damaged areas from a lipped bottle so it spreads out on the surface. In the vacuum most of the moisture disappears. As the table can be lit by transmitted light the defective spots are clearly visible. The pulp must not be spread onto the script. The completed leaves are lifted from the vacuum table together with the silk sieve; they are pressed under felt sheets, and after a few weeks of drying, sheets are made from the leaves. They were stitched onto hemp cords, and the text-block was made in the usual way; the text-block was rebound in its repaired leather

cover. The paper and parchment strips with the manuscript fragments (which had been used to cover imperfections) were cleaned, restored and carried to the original repository of the codex together with the documentation of the conservation process.

The climatic conditions of the repository were analysed at the request of the Oriental Collections. It was suggested that the manuscripts should be kept in a room where the relative humidity is between 55-60% and the temperature is between 18-20°C; any fluctuation in these conditions should be avoided. Under these conditions the leaves of the codex stored in a protective box will not become wavy or deformed, and the miniatures can be preserved in good condition. Conservation was implemented by Krisztina Ballagó Fischer, Ildikó Beőthy Kozocsa, Mária Czigler and Ágnes Kálmán Horvát, co-workers at the Conservation Laboratory of the National Széchényi Library.<sup>16</sup>

was probably bound in its current cover by D. Kaufmann.

- <sup>12</sup> Mould was not identified during the analysis.
- <sup>13</sup> The drugstore beetle (*Stegobium paniceum*) feeds on glue.
- <sup>14</sup> The solution of Preventol CMK (p-Chloro-m-Cresol) in ethanol.
- <sup>15</sup> Beőthy Kozocsa, I., Sipos Richter, T. and Szlabey, Gy op. cit. Beőthy Kozocsa, I. (1988) 'Some Problems and Achievements in Codex Restoration in the National Széchényi Library' in I. Éri and G. Sárközy (eds.) *Sixth International Restorer Seminar Veszprém, Conservation-Restoration of Leather and Wood - Training of Restorers*. Budapest: 233-340. Wouters, J. (2000), 'The Repair of Parchment: Filling', *Reviews in Conservation* 1: 77-86. Beőthy Kozocsa I., Siposné Richter T. and Szlabey Gy (1990), 'Parchment Codex Restoration Using Parchment and Cellulose Fibre Pulp', *Restaurator* 11: 95-109.
- <sup>16</sup> I would like to convey thanks to I. Ormos at the Oriental Collections of the Hungarian Academy of Sciences for providing me with useful information about the manuscripts. This information contributed to the successful planning and implementation of the conservation process.

## Endnotes

- <sup>1</sup> One of the invaluable Hebrew manuscripts is an illuminated parchment codex (ref. A 422); the other is another Hebrew manuscript (ref. A 384).
- <sup>2</sup> *The Kaufmann Haggadah. Facsimile edition MS 422 of the Kaufmann Collection in the Oriental Library Hungarian Academy of Sciences*. Introduction by Alexander Scheiber, Budapest, 1957: 55. Appendix 1: 29
- <sup>3</sup> The analysis was carried out by Z. Szabó; the data were taken from his report.
- <sup>4</sup> The size of the codex leaves is 185 x 220 mm; it is written on parchment and contains 60 leaves (120 pages).
- <sup>5</sup> Miksa Weiss: Néhaj dr. Kaufmann Dávid tanár könyvtárának héber kéziratai és könyvei [The Hebrew Manuscripts and Books from the Library of the Late Professor Dr Dávid Kaufmann] Budapest 1906. This condition report was mentioned in *Die Haggadah von Sarajevo* by D. H. Müller and J. von Schlosser (1898) pp. 187-99.
- <sup>6</sup> The beaten white of an egg (approx. 30 g.) is drained, 15 g of French vinegar (5%) is added, some crystals of Nipagin (methyl 4 hydroxybenzoate) are dissolved in ethanol, equal to 20% of the whole quantity, and we add a few drops of Solovet R surfactant (Dyoctyl Sodium Sulphosuccinate). It is mixed and diluted to make a double quantity in distilled water. This emulsion is painted twice under a magnifying glass.
- <sup>7</sup> The solution is 2% w/v of Klucel M (hydroxy-propyl-cellulose) in methanol.
- <sup>8</sup> Bondina is a polyester, non-woven fabric made in England.
- <sup>9</sup> Goldbeater's membrane is a completely transparent membrane made from a cow's appendix; the glue is a mixture of rice starch and a small quantity of polyvinyl-acetate.
- <sup>10</sup> Beőthy Kozocsa, I., Sipos Richter, T. and Szlabey, Gy. (1987) 'Report on Parchment Codex Restoration by Parchment and Cellulose Fibre Pulp'. *ICOM Committee for Conservation 8th Triennial Meeting. Preprints*, Sydney, Australia. 6-11 September, Vol. II: 641-8.
- <sup>11</sup> The number of the illuminated parchment leaves of the manuscript is 251; the size of the leaf is 330 x 220 mm. It

The conservation of cultural heritage has undergone many changes in the last thirty years. The focus has widened from treating individual objects in the conservation laboratory to encompass caring for collections of objects in the whole museum, e.g. via integrated policies and practices of preventive conservation. The 2002 triennial meeting of the Conservation Committee of the International Council of Museums (ICOM) manifested a further shift of emphasis, moving from collections to the community. As part of the Rio Meeting there was a Museum Forum called 'Community Involvement in Conservation', in which museum colleagues showed how they have seized opportunities for community involvement in conservation.<sup>1</sup>

[ DINAH EASTOP ]

# Conservation decision-making:

FROM OBJECT TO COLLECTION TO COMMUNITY AND BACK AGAIN

**T**he Museum Forum, which was organized by ICOM rather than by ICOM-CC, introduced a fascinating range of community initiatives, mostly in Latin America. The following account<sup>2</sup> summarizes some of these presentations, links them to recent analysis of decision-making in conservation, and considers implications for the future practice of conservation.<sup>3</sup>

General of ICOM, Manus Brinkman, stressed that awareness of cultural heritage cannot be taken for granted; for some people an archaeological site was a heap of stones. For conservation to take place, the sites/artefacts/practices must be considered worth preserving. For this reason he supported initiatives which encouraged active local involvement in conservation.

## Strengthening awareness of natural and cultural heritage as a future resource

At the start of the Forum, the President of ICOM LAC (Latin America and the Caribbean), Luis Repetto Málaga, argued that heritage must serve communities, and that this commitment should be stated explicitly in state cultural policies. The Secretary

## Intangible heritage: a community response

The case studies started with Liliana Graciela Barela, an historian, who reported what she described as a 'cultural resistance phenomenon'.<sup>4</sup> She introduced an oral history project in Buenos Aires, Argentina. We were shown a video of the team's recording of people's feelings and actions sparked by the closure and destruction of a corner café (El Café Angelitos).

The café, founded in the Balvanera district in ca.1900, became legendary. Its name ‘little angels’ was an ironic reference coined by the police because of the many local fighters who used the café. By the 1940s the café was associated with the tango, said to have been invented there. The café closed in 1992, and later the roof caved in. In order to demonstrate their feelings of loss, local residents and people who used to walk by the café began weekly tango dances on the street outside the closed café. Locals said they were dancing in homage to the café. Barel described the café as having symbolic value, rather than being considered of architectural or artistic value: spirit of place was important. Rather than accepting modern cafés which demonstrated a homogenization of globalized style, locals said they wanted to ‘rebuild a meeting place of our own’. Barel argued that the actions of the local community showed a love of the intangible (in this case meeting, dancing, playing music, and looking). She added that oral history is the best tool with which to evaluate intangible heritage.<sup>5</sup> One of the later speakers emphasized that tangible and intangible heritage were inseparable categories, interpenetrating each other.

## Re-development: civic and state initiatives

Carola Alejandra Brito Castro described a huge ‘civic development’ project to ‘recover local heritage’ at La Casa de Maquinas de Temuco, Chile. Temuco is famous as a railway town and as the birthplace of the poet Pablo Neruda, whose father was a railwayman. The obsolete station, with repair workshop, was listed as a heritage site in 1985 and 2000; it includes a huge revolving stage (which can be operated by a single person) of 1937-41, a coal-elevating building, 15 steam locomotives, carriages and a crane. The railway buildings are to be preserved and put to new uses; for example, the vast circular revolving stage will be roofed over (like the British Museum’s Great Court) to form a museum, and a landscaped playground will encircle the museum. It is proposed that the coal-elevating building will house the Neruda Museum.

An amalgamation of community and state was evident in the next presentation. Maria Claudia Ferrer Rojas described the establishment of ‘Guardians of Cultural Heritage’ in Colombia. The aim of the Ministry of Culture is to encourage community participation in conservation, by acknowledging different perspectives and the fact that everyone can be an accomplice to negligence. The scheme’s motto is ‘Discover, Value and Preserve’. Projects

include: scrutiny of building repairs; the development of a book and toy to encourage children’s interest in historic sites; classes in the technology of adobe and stone roads. The Guardians are local volunteers, including children, who undertake some training, have a distinctive uniform, sign a written agreement with the Ministry of Culture, and who are sworn in as Guardians at a special ceremony. The project is linked with citizenship initiatives designed to encourage political stability and support for the current government. Recovering democracy is linked with preserving heritage. There are currently 67 ‘guardian groups’, with two in the conflict areas in S.E. Colombia, one linked to the archaeological park of San Agustin, a World Heritage site.

Sigfrido Jiménez Regidor described community involvement with the Museo de la Cultura Popular, Costa Rica. The museum is responsible for the maintenance of hacienda (farmhouses) built using a wattle-and-daub technique. He contacted local people who were skilled in these techniques and a network of local specialists was created; this led to workshops with schools, universities and other local groups. Benefits included community involvement in the museum’s work; support for local tourism with new hotels being built in traditional techniques; and support for local workmen. The national building code of 1901, which prohibits ‘wattle-and-daub’-type building, is under review.

## Building memories

One of the most moving presentations was by Milton Doño, one of two persons who run the archive programme of the Museo de la Palabra y la Imagen (Museum of Word and Image), in El Salvador. The archive programme was set up, without any government funding, but with Dutch support, after the end of armed conflict in El Salvador in 1992. In 1997 an archive campaign was launched to defy ‘chaos and oblivion, and the loss of memory’. The aim of the archive is to ‘build memories’ by documenting and collecting pictures and letters, e.g. by collecting records of a massacre of 10,000 people, and by preserving the records of writers from El Salvador. He and his single colleague tour the country with artefacts and audio-visual material, both to share the collections and to encourage people to share their memories. A recent touring exhibition was called. ‘Fingerprints of Memory’. He acknowledged that sharing memories is painful; he believed such ‘memory work’ was essential to securing a safe future for El Salvador <<http://www.museo.com.sv/IntroMu.html>>.



## Conserving the material and the symbolic

Maria Eugenia Marin described community (in this case mostly adult male) involvement in the conservation of a carved wood figure of Christ from a grotto shrine in Iztapalapa, Mexico. Here it was considered essential to agree on interventions necessary to conserve the material, function and symbolic properties of the sculpture. Great care was taken to handle the figure with due respect; to encourage bi-monthly visits of community representatives to the conservation studio to witness and advise on the treatment undertaken; and, to provide preventive conservation advice that could be implemented on the figure's return to the shrine. She stressed the importance of strengthening awareness of both natural and cultural heritage as a future resource.

Rommel Angeles Falcón, an archaeologist, introduced an 'Adopt a Textile' programme instigated by ICOM Peru, and led by him and Denise Pozzi-Escot. The scheme, with only two paid staff, involved getting local schoolchildren, local businesses and tourists to sponsor the conservation of excavated textiles. The project was designed to foster local interest and appreciation of the site. Visits to the site were encouraged with the aim of making visitors value both the site and the excavated material, so as to help protect against illicit trade and looting. Local interest has been maintained, e.g. school children painted the walls of their school with designs drawn from the textiles; and, one class, from a poor neighbouring town with 3,000 inhabitants, spent six months raising funds to pay for the costs of conserving just one textile. Fifty textiles have been conserved, and they have been exhibited in Lima and Washington, DC, USA. Hundreds more textiles are awaiting treatment. The success of the project led the Municipality of Asia to construct the Municipal Museum of Huaca Malena in order to exhibit the 'adopted' textiles. The following website was developed thanks to a local telecommunications company: <<http://huacamalena.perucultural.org.pe>>

## Networking

In 1989 a meeting was held in Costa Rica on Sustainable Heritage. It was recognized that creating and sustaining a participatory structure was essential. There are 4,380 museums in Latin America, and a collaborative site has been established: <Red-ILAM. [www.ilan.org](http://www.ilan.org)>. This on-line site won an award in

2000 for 'Patrimony on line'. ILAM is the Institute of Latin American Museums. It aims to: identify successful initiatives; foster access to technology; create a directory of stakeholders; and, supply on-line information. Inclusion and democratization were described as the keys to success.

In addition to the Museum Forum, other evidence for the growing interest of ICOM-CC in community involvement in conservation includes: (a) the setting up of a Task Force on Public Awareness and Involvement in Conservation (two-way dialogue between conservators and the public) within ICOM-CC; (b) the acceptance for a resolution on communication by ICOM-CC in Rio; (c) the selection of 'Community Involvement in Conservation Decisions' as one of the four key objectives of the Ethnography Working Group of ICOM-CC.

## Discussion

A growing awareness and commitment to 'Community Involvement in Conservation', particularly decision-making, was evident at the Rio meeting of ICOM-CC. What was refreshing about the Museum Forum was the explicit recognition by the speakers from Latin America of the overtly political nature of their work. The work of preservation and documentation was explicitly linked with initiatives to foster democracy and citizenship. The speakers were proud to state that as heritage professionals they were actively engaged in local, regional and national politics.

As a corollary to the political dimension, issues of cultural value were acknowledged as influential in conservation decision-making. 'Community involvement' makes it necessary to address openly what is to be preserved: is it the material, the functional and/or the symbolic properties of objects/sites? Some of these issues are addressed in a fascinating set of essays edited by Marta de la Torre (2002). Clavir's analysis of conservation practices in N. America and their relation to First Nation Community use of museum artefacts has focused attention on what is valued and by whom (Clavir 1994, 2002; the latter reviewed by Odegaard 2002). The papers presented in Rio add another dimension to the challenges of 'Preserving what is valued' (the title of Miriam Clavir's 2002 book). The preservation of memories, artefacts, and ways of being, as described in the Rio Museum Forum, can be understood as ways of working for the future while resolving past conflicts in Latin America. The personal investment of meaning is seen as part of a community response to local histories. Cultural artefacts/sites are shown to be a part of life which is politically contested.

This overtly political dimension may present a challenge to much European conservator/curator education. State bodies in Europe determine the future of cultural artefacts, with limited community involvement, supporting the notion of heritage conservation as an uncontested political field.

It is one thing to tell the community what we (the conservators/curators) are doing, and to invite comment. It is quite another to facilitate and accommodate more active practices of community involvement. It is perhaps a significant omission that not one of the case studies in the 'Community Involvement in Conservation' forum mentioned any need to resolve inevitable differences arising between different local communities, professional groups and state agencies. If community involvement in conservation becomes an accepted policy, how in practice will heritage professionals respond to conflicting demands within and between local communities, funders and professional bodies?

## Dedication

For me, the Museum Forum was one of the highlights of the Rio meeting. The saddest aspect was the absence of Dr. Ágnes Timár-Balázsy, a dear friend and colleague, who had become an essential and much-loved part of ICOM's Conservation Committee. She would have loved Rio; we missed her wise and joyous presence very much.

## References

- Berducou, M. 2002. Why involve the public in heritage conservation-restoration? Is it important? 'Nous du service des signes'. In: D. Grattan, ed. *Conservation at the End of the 20<sup>th</sup> Century. Plenary Sessions from the 12<sup>th</sup> Triennial Meeting of ICOM-CC, Lyon, France, 1999*. Paris: ICOM: 15-18. [Paper also published in French in the same publication.]
- Clavir, M. 1994. Preserving conceptual integrity: ethics and theory in preventive conservation. In: A. Roy and P. Smith (eds.) *Preventive Conservation. Practice, Theory and Research*. London: IIC: 53-7.
- Clavir, M. 2002. *Preserving what is valued. Museums, conservation and First Nations*. Vancouver: UBC Press (University of British Columbia).
- Grattan, D. ed. 2002. *Conservation at the End of the 20<sup>th</sup> Century. Plenary Sessions from the 12<sup>th</sup> Triennial Meeting of ICOM-CC, Lyon, France, 1999*. Paris: ICOM. [Papers published in both English and French]
- Odegaard, N. 2002. Book Review. Miriam Clavir. Preserving what is valued. Museums, conservation and First Nations. Vancouver, Canada: UBC Press (University of British Columbia). Museum of Anthropology Research Publication, 2002, 320pp. ISBN 0-7748-0860-8. *Journal of AIC*, Fall/Winter 2002, Vol. 41, No. 3: 300-2.

Torre, M. de la. ed.) 2002. *Assessing the Values of Cultural Heritage*, Research Report. Los Angeles. Ca.: Getty Conservation Institute.

## Endnotes

- <sup>1</sup> Berducou recently asked: 'Why involve the public in heritage conservation-restoration? Is it important?' (Berducou 2002:15). This question was raised at the plenary session of the 1999 meeting of the ICOM-Conservation Committee in Lyon (Grattan 2002). The debate was continued at the Rio meeting of ICOM-CC via the Museum Forum.
- <sup>2</sup> This account is based on a report I prepared for ICOMUK News, and published as: Eastop, D. 2002, Conservation as a democratizing practice: learning from Latin America. *ICOMUK News*, 63: 22-4.
- <sup>3</sup> Papers presented at this excellent forum have not been published, but I hope they will be. Of all the papers I heard in Rio, these are the ones that I would most like to see published, ideally with English and French translations. The recent publication of the papers presented at the plenary session of the ICOM-CC meeting in Lyon sets an excellent precedent for publication (Grattan 2002).
- <sup>4</sup> Most of the presentations were given in Spanish. What I listened to, and quote above, were the simultaneous translations into English.
- <sup>5</sup> Preserving intangible heritage is the subject of the 2004 General Assembly of ICOM in Seoul, Korea.

*In memory of Ágnes, my dear friend and colleague for many years.*

It is not an ordinary piece of linen that has been handed down to us in the cloth preserved in Turin. It is distinguished by features that have caused it to become an important and, at the same time, much debated document of Christianity. There is no parallel for the image of a human body, seen from the front and from the back, on one side of the cloth. This body displays all the characteristics of a crucified man who suffered the same destiny as described in the Bible for the crucifixion of Christ. For centuries this fact made the cloth the most important relic of Christianity, and also the most controversial one.

MECHTHILD FLURY-LEMBERG

# The image of a crucified man on the Turin Shroud:

## MEASURES TAKEN FOR CONSERVATION OF THE LEGIBILITY OF THE BODY IMAGE

**T**he linen fabric, a 1/3 twill weave in herringbone structure, which appears yellow today, was originally the colour of natural linen. Traces of blood have been authenticated on the Shroud, but no paint pigments could be found. The blood had seeped through to the reverse of the cloth, whereas the representation of a 'photographic negative' (extraordinary in itself) only affects the top fibres on the face of the Shroud. (Fig. 1) Obviously, an uncommonly strong oxidation has occurred in these places, resulting in a visibly darker brown. The image of a male body is clearly distinguishable, but without sharp outlines in these darker brown areas on the lighter-coloured, yellowed linen background. How this detailed representation of a human being happened to come onto this cloth still is a mystery. It is clear, however, that we are not dealing with a drawing or a painting here.<sup>1</sup>

As might be expected in the case of the Shroud of Turin, the tradition is especially difficult. I shall only mention the main dates.

Certain knowledge of the existence of the linen goes back to the fourteenth century. The preceding period is still full of question marks. In 944, the linen probably went from Edessa to Constantinople, where it is said to have been present in 1204.

It is not clear how it eventually came into the possession of the knight Geoffroy de Charney, at Lirey in France. There are sources directly connected with the object since 1389. In 1453, Margarethe de Charney La Roche brought the linen into the possession of the Savoy dynasty. In 1502, the Savoy brought the Shroud to the Ducal Chapel of Chambéry, where it was seriously damaged by a fire in 1552. The holes caused by the fire were restored on the spot by Poor Clare nuns with patches of linen cloth. Since that time, the Shroud has been characterized by the patches covering the holes caused by the fire. (Fig. 2)

In 1578, the Shroud came to Turin, the capital of the Savoy. Since 1694 it was kept in the chapel

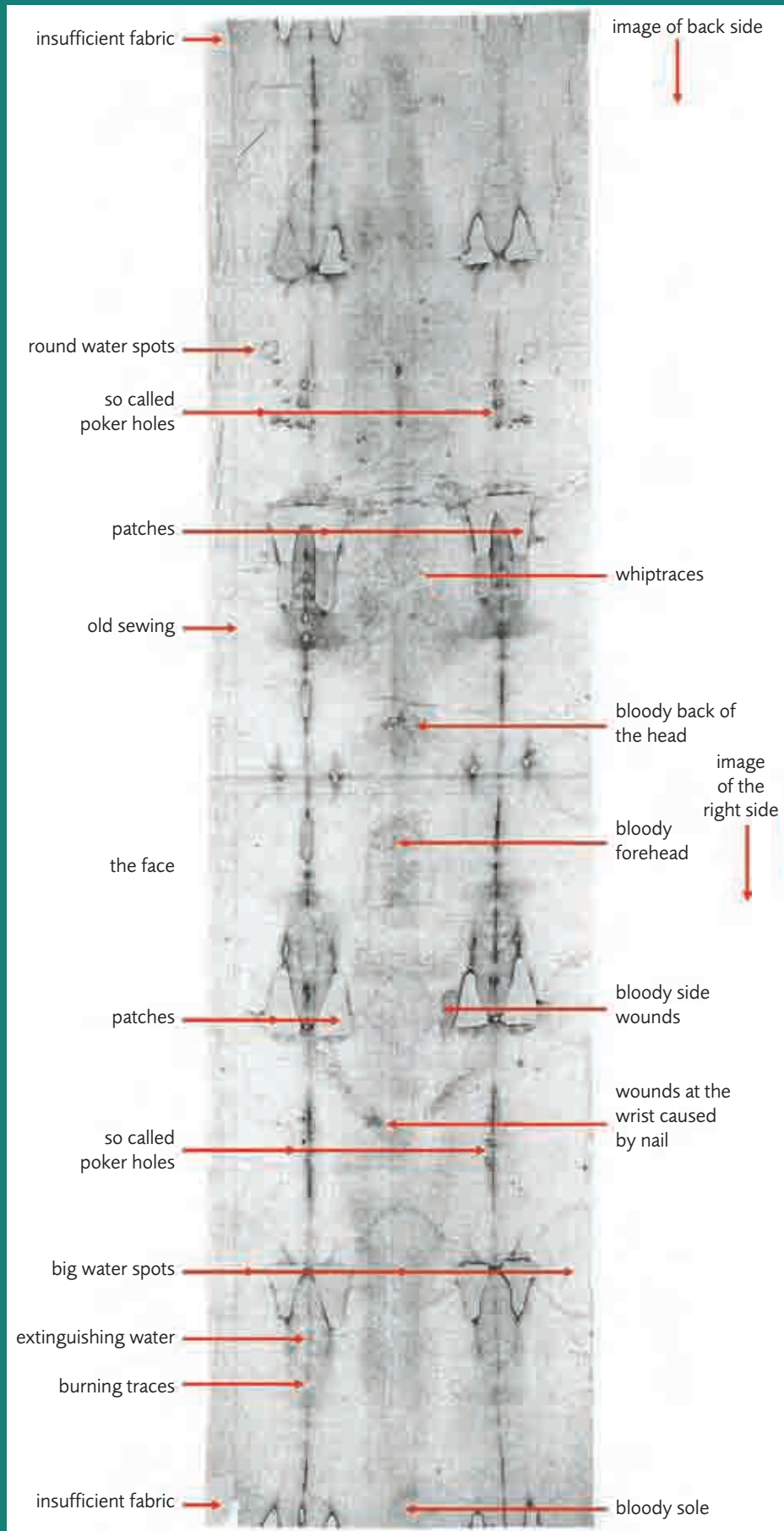

FIGURE 1 Photographic negative of the back side of the Shroud



FIGURE 2 Holes caused by the burning of 1532 covered by spots

built by G. Guarini until a fire in 1997 destroyed the beautiful chapel. Fortunately the Shroud was saved without any damage.

In 1889 the first photograph of the Shroud was made by Secondo Pia.

The photo negative showed a natural image which had not been visible before because the linen itself shows a negative picture of the image. From that moment on, modern scientific research began – the so-called ‘Sindonologia’. A huge variety of different scientific disciplines have since been employed to research the Shroud.

In 1988, the results of Carbon 14 analysis dated the Shroud to the medieval period, between 1260 and 1390. This result is extremely doubtful for a number of reasons, i.e. because we have a remarkable source for the existence of the linen as early as 1192/95, based on the Pray Codex (Széchenyi Library, Budapest). (Fig. 3)

This manuscript contains two miniatures, one depicting the anointing of the body of Christ and the other the women visiting the empty tomb; careful analysis revealed a curious representation of Christ’s Shroud. In the upper part of the picture, the cloth on which Christ’s body is laid is white, with no pattern, as one would normally expect. However, in the scene of the women at the empty tomb, the funeral cloth depicted has two clearly visible features: first, a series of four holes arranged in an ‘L’ shape, whose position and shape correspond to those of the so-called ‘L-holes’ in the Turin Shroud; and, second, the entire Shroud is depicted with a stylised herringbone pattern.

All this is unusual and extremely significant, because it shows that the painter was familiar with Christ’s Shroud and that he recognized the indubitably exceptional nature of the weave of the cloth, a sign of its value. This kind of weave was special in antiquity because it denoted extraordinary quality. While he was drawing the weave and the holes, the painter of the Pray Codex managed to leave as a ‘signature’ on the cloth the signs of a sheet that he already knew as Christ’s funeral cloth. As a result, this source is much more significant than any comparison with an ancient artefact could be, and for the textile historian it is equally powerful.<sup>2</sup>

The linen fabric of the Shroud, though marked by past damage, has survived until today without special measures taken for its preservation. The fibres of the linen are in very good condition and there would be no cause for concern if it were not for the image of a crucified man. The Shroud of Turin is a unique relic, the meaning of which rests solely in this image, independent of the proof of its authenticity. All efforts regarding the conservation of the Shroud must, therefore, aim at preserving this image.

The phenomenon of the image on the linen fabric is due to an as-yet unrecognized process which affected only the topmost layer of the fibres. The yellowing of the linen, however, was caused by the naturally occurring process of oxidation. This process can be observed in daily life on yellowed tablecloths which have been kept unused in a linen closet for some time. The image, also the product of some kind of oxidation, is only a few degrees darker than the background and therefore needs to be preserved if the testimony of the Shroud is to be passed on to future generations. Conservation would therefore consist of stabilizing the lighter colour of the linen foundation weave in order to avoid possible ‘absorption’ of the relatively delicate lines of the image into the darkening colour of the background, which would render the image unrecognizable. It is therefore a matter of some urgency to find effective measures to counteract the oxidation process.

The Shroud in its ‘new wrapping’ after the Chambéry fire, though always treated with great care, had been exposed to agents that can accelerate the process of oxidation. The possibility that residues of burnt material in the areas of the holes caused by the fire could be trapped between the linen backing cloth and the patches applied by the nuns was soon recognized as a danger. As these substances can considerably accelerate oxidation, and as the consequences of future water damage would be devastating for the Shroud (because the combination of water and burnt residue would produce a black dye) the fundamental question arose early on of removing the patches, so that the areas around the holes could be cleaned.

In 1993 the scientist Alan Adler<sup>3</sup> suggested that removal of the patches would be the most effective way to reduce oxidation. Although I agreed with Adler in principle from the beginning, I was unable at that time to accept this fundamental solution. Arguments around the inviolability of the historical conservation work done by the Poor Clares of Chambéry, as well as concerns that the optical appearance could be changed, had first to be over-ridden by the proven danger.

So all these deliberations led to the decision to keep the Shroud for the time being in an oxygen-free showcase (filled with the inert gas argon). The problems due to the staining of the Shroud in the Chambéry fire preoccupied the committee again and again in the following years.

In November 2000 we did not foresee that one day the linen (‘Holland’) cloth lining would be removed. Only the thorough investigation carried out on the lining on that occasion revealed the whole dramatic meaning of the staining.<sup>4</sup> I had never had the opportunity to view the lining in its entirety before.



Entombment of Christ

The Angel and the Saint Women visiting the tomb of resurrected Christ

FIGURE 3 Miniatures from the Codex Pray (page XXVIIIth on the right side)

Now it turned out that all the holes caused by the fire showed as dark grey stains on the lining at the back of the Shroud. (Fig. 4) Under the microscope, these stains turned out to be carbon dust embedded between the fibres. Thus it became obvious that residues from the fire were present in the areas of the holes between the lining and the patches. This clear evidence finally made it possible to come to a decision about whether or not to remove the lining. It is self-evident that the visibility of the image took precedence over possible loss of historical evidence. Fortunately, this reasoning did not have to be applied to the original state of the Shroud, but rather to the sixteenth-century conservation work, also implemented out of concern for the Shroud's preservation. The 1534 conservation work of the Poor Clares is certainly of historical interest and therefore needs to be analysed and noted for future research, but it does not represent a value in its own right. The same is true for the conservation measures undertaken in 2002. All these deliberations finally led the committee to unanimously recommend

to Cardinal Poletto that the patches and the Holland cloth lining be removed for reasons of preservation.

When the conservation began with the removal of the Holland cloth lining on 20 June 2002, it became abundantly clear how necessary this decision had been. The great amount of carbon dust that surfaced from under the sewn-on patches widely surpassed our fears. Not only were the holes surrounded by a minimum of 5 mm of totally charred fabric, but the black carbon dust was also visibly embedded in all the sound fibres of the areas around the holes, the patches and the lining. In addition, piles of black soot, up to a teaspoonful, were to be found under the patches. (Figs. 5-6)

There was evidence of oxidation of the fabric around the burn holes since the patching. We must assume that the Poor Clares removed all the fragile residue and in particular the soot from the burn marks before they started applying the patches. The extremely careful needlework was done without any signs of marking from soot. At that time there could not have been such quantities of soot. Contiguous areas of soot would not have survived the necessary handling required for the needlework: they would have fallen apart. All the fragile threads that we found would undoubtedly have disintegrated during any work done, just as today they fall apart at the merest touch. The fine soot, which can penetrate the tiniest crevice, would have stuck to the needlewomen's damp hands and left black marks on the Shroud. The nuns could only attach their patches to the good fabric, which they did, as can be seen from the needlework. Where the nuns left too small an overlap in an effort to cover as little of the original cloth as possible, as in the case of the blood stains, the seams came away. Here and there holes formed over the years on the burn marks which did not need any work in 1534 but later required extensive patching or darning.

These signs of advanced oxidation were one of the principal reasons it was decided to remove the patches and the Holland cloth lining. Through the alternation of humid and dry conditions, the presence of acidic burn residue under the patches promoted a microclimate which had already caused oxidation of the cellulose fibres.<sup>5</sup>

Evidence of this process can be seen around the L-shaped holes, for example. At the corresponding point on the back of the lining one can clearly see how oxidation had already affected the lining material, causing it to go brown. In addition, all of the Holland cloth lining was extremely dirty owing to the Shroud's having been much handled on the outside. As a lining, the Holland cloth served to protect the Shroud from dirt, but at the same time

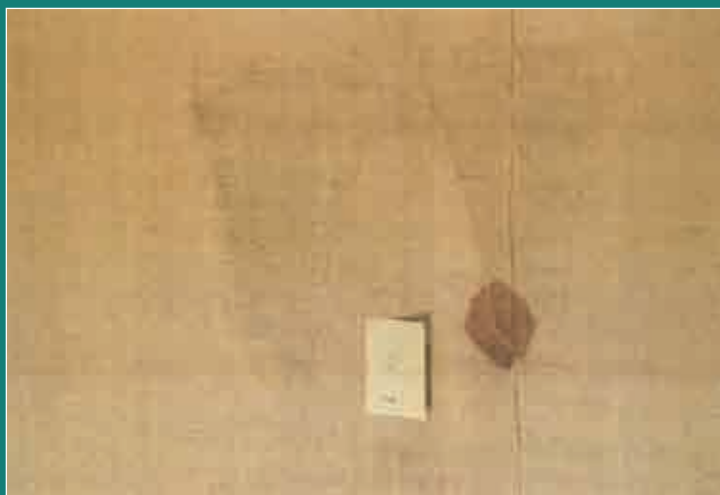

FIGURE 4 Spots on the back side of the Shroud



FIGURE 5. a

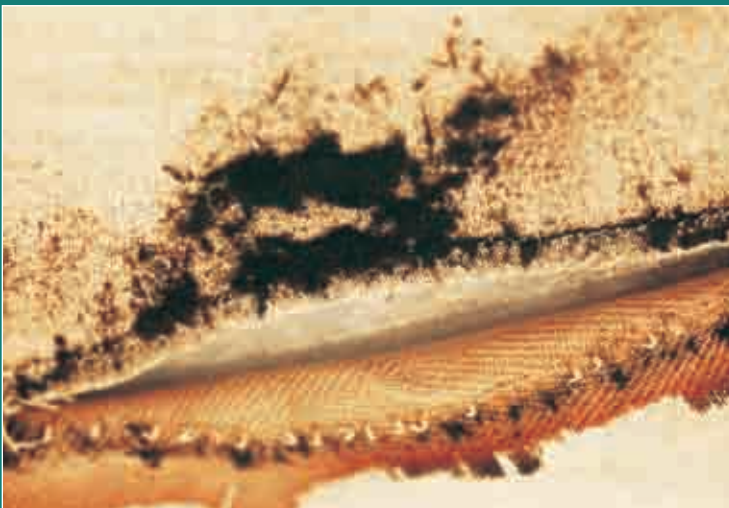

FIGURE 5. b



5. c / FIGURES 5a–c Black carbon dust on the patches, on the surface of the Shroud and on the Holland cloth

it caused the entire Shroud to be maintained in an environment of soot resulting from the burn residues, which penetrated all the fibres.

After the Holland cloth was removed, the back of the Shroud and the back of the patches containing the carbon dust became visible. Thick black soot was embedded between the fibres of the lining, amassed on the patches and on the areas of the Shroud which had been covered. (Fig. 5)

The carbon dust was first removed superficially with the help of a small vacuum cleaner designed for delicate tasks and provided with a built-in filter to catch even the smallest particles (micro-pipette technique). (Fig. 6) The absorbed material was stored in small glass bottles and its provenance noted. Then the detached patches were removed. Approximately 5 mm of the totally burned fabric from the edges of the holes was removed by tweezers to free the Shroud as much as possible from substances that promote oxidation. The edges of the fabric were found to be already oxidized to such a degree that they disintegrated into dust when touched. (Fig. 7) The brittle material was removed, collected and labelled.

With utmost care, and avoiding the traces of blood, the spaces around the holes were then cleaned a second time. It became clear, using a video microscope, that much of the harmful carbon dust was still left in the fabric of the Shroud after the first surface cleaning.

As so often happens in the practice of conservation, the case of the Shroud demanded a compromise. From the point of view of conservation, the ideal solution would be to store the Shroud in a horizontal position at all times. Only in that position could the Shroud be left safely unfixed without any danger. This would also enable both sides (the front as well as the back) of the Shroud to remain accessible in the future. However, the Shroud has its own logic, because any conservation measure had to sustain its continued use as a relic. This meant it had to be guaranteed that Christians from around the world could continue to have ‘access’ to the Shroud via future exhibitions. Although the fabric itself is in relatively good condition, the Shroud cannot be displayed in a vertical position if it is not fixed on a support fabric because of its many damaged areas. Nonetheless, a horizontal positioning of the Shroud is out of the question for any exhibition, as the flow of visitors would be unmanageable. Securing a longer life span for this unique relic was of paramount importance, and the least damaging means of display had to be guaranteed as well. As the best way of exhibiting the Shroud was (and will continue to be) a vertical display, the Shroud had to be fixed onto a support fabric in order to give it the necessary stability.



The shroud was laid onto a fine, tabby weave, linen fabric (in its most natural state, with no added chemical substances); the Shroud was held in place by hardly discernible couching stitches,<sup>6</sup> mainly around the edges of the holes. The stitching was worked in pure silk threads (organzine), the width of a hair, and worked with appropriately fine needles. It is very easy to undo these fine stitches, if necessary, within a day. No traces will be left of the stitching. The fixing is completely reversible. The silk threads are very fine and flexible which makes them disappear into the weave. They also are just strong enough to respond to any significant strain and break 'before' they cut into the original fabric and thus cause damage.

As was to be expected, the Shroud appears in a new light after the conservation work. (Fig. 8)



FIGURE 6 Removing of the carbon dust with a special vacuum cleaner



FIGURE 7 Removing the burned fabric by tweezers

The exposed burn holes considerably increase the impression of a cloth that has suffered damage; this damage was in evidence up to the fire at Chambéry. Removing the patches has given the Shroud more substance than we expected. The form of a person in agony has become more recognizable altogether because the lines are no longer broken by the patches. The dramatic damage caused by the fire literally reflects how the Shroud had been folded previously. This also serves to lend the cloth more significance. Before starting the conservation work, we were concerned that removing the patches would spoil the Shroud's appearance from the observers' point of view, but this has proved unfounded. Still, our fears that residue from the fire might have a negative effect on preserving the priceless imprint were fully confirmed by what we found under the patches.

Refraining from carrying out necessary preservation work entails no less responsibility than carrying it out! As a rule, this type of task always ends in a compromise. Losing the context of what happened in 1532/34 in Chambéry was a price that had to be paid. This regrettable loss does not concern the substance or the significance of the original Shroud, however. In view of the justified fears, this change had to be accepted, particularly since it was possible to document the circumstances of the Chambéry restoration for posterity. In addition, it is regrettable that material was lost, although despite being removed from its original context it has been safely archived and is available for research purposes.

Should this valuable cloth, this relic, have been left untouched?

That is the kind of question we face with each object when we are responsible for guaranteeing its survival. Obviously the religious character of the Shroud does not call for an exception. On the contrary, we ought to be even more careful with this important relic as far as the risks of future damage are concerned. We ought to minimize these risks as much as possible.

Such decisions should always be based on a complete analysis and by carefully weighing up the results, and taking into account all the object's circumstances.

Professional analyses no doubt form the basis for all our conservation measures, but it would be a failure if we were to carry out 'analysis for the mere sake of analysis'! The result of the analysis itself is not enough; it also calls for courage in action. We are also responsible for 'doing nothing'. In the case of the Turin Shroud, the latter would have been an irresponsible approach.

(Figures by Giovanni Pisano, Gian Carlo Durante, Giuliano Marchisiano.)



FIGURE 8  
General view of the front of the Shroud  
before and after  
the removal of the Chambéry patches



## Endnotes

---

- 1 Flury-Lemberg, M. (1998). Stato e Problemi di Conservazione della Sindone di Torin. In: B. Barberis and G. M. Zaccone (eds.) *Sindone. Cento Anni di Ricerca*, Torino: 255-67; Flury-Lemberg, M. (2000). The Linen of the Turin Shroud. In: *The Turin Shroud, past, present and future, International Scientific Symposium*, Turin, 2-5 March 2000: 26, figs. 6a,b; Flury Lemberg, M. (2001). The Linen Cloth of the Turin Shroud: Some Observations on its Technical Aspects. *SIDON Nuova Serie*, Torino, Anno XIII No.16: 55-76; Flury-Lemberg, M. (2001). Spuren einer wechselvollen Geschichte auf dem Grabtuch von Turin. *Das Münster, Zeitschrift für christliche Kunst und Wissenschaft*, 1:17-29.
- 2 According to the historical sources the Turin Shroud was in Constantinople until 1204 when it disappeared when the city was occupied. Bela III the king of Hungary between 1172-96 married the daughter of the Byzantine emperor Manuel I. In that time there was a very close contact between Hungary and the Byzantine Empire. That can be the reason why the picture of the Shroud can be found in the codex Pray (1192-95) which is still preserved in Budapest, the capital of Hungary See the following: Wilson, J. (1980), *Eine Spur von Jesus*. Freiberg: 49. Csocsan de Várallja, E. (1987), The Turin Shroud and Hungarie, in *Ugarnbuch*, 15: 1-49; Werner Bulst, *Betrug am Turiner Grabtuch*. Frankfurt, 1990: 49; Flury-Lemberg, M. (2001), A cloth of inestimable worth, in G. M. Zaccone (ed.) *The Two Faces of the Shroud*. Turin:137-42; Leconte, A. (2003), Very disturbing similitrics; Pouille, E. The holy Shroud and the dating of the codex Pray, in *Revue Internationale du Linceul de Turin*. Paris, Vol. 25: 2-5, 7-19.
- 3 Adler, A.D. (1991). Conservation and Preservation of the Shroud of Turin. *Shroud Spectrum International*, 40:5. 'How serious are these problems? Could the quality of the Shroud's appearance seriously deteriorate within the next decade or so? It is not impossible, unfortunately there is some evidence that it is progressing right now. If we are remiss in undertaking conservation/preservation studies and measures on the Shroud of Turin, future generations will have every right to castigate us for failing to meet our responsibilities in these matters. History will not be kind to us!'. Also: Adler, A.D., and Schwalbe, L. (1993), Conservation of the Shroud of Turin, in *Shroud Spectrum International*, 42:7-15; Adler, A.D. (2002), The orphaned manuscript, *A Shroud Spectrum International Special Issue*: VII, 25.
- 4 Flury-Lemberg, M. (2002) *Sindone, L'Intervento Conservativo, Preservation, Konservierung*. Torino 2003 ODPE.
- 5 Hofenk de Graaff, J.H. (1994), Research into the cause of browning of paper mounted in maps, in *Contribution of the Central Research Laboratory to the field of conservation and restoration*, 21-43.
- 6 Flury-Lemberg, M. (1988), *Textile Conservation and Research*. Berne: Abegg-Stiftung: 42.

A woman's court dress, probably made in the middle of the eighteenth century, came into the possession of the Hungarian National Museum by way of exchange early in 1984.<sup>1</sup> The costume was altered for a woman in the family so that she could wear it in 1896 for the festivities to commemorate the 1000<sup>th</sup> anniversary of the foundation of the Hungarian state. It was offered to the museum by a collector of metals and weapons who had a remarkable professional and ethical background, and who had maintained a good relationship with the museum for several years. He recognized the value of the dress immediately, and also provided the museum with useful information about the family, as he was aware of the importance of establishing provenance when acquiring artefacts for museum collections. In exchange for the costume in excellent condition he received two chamberlain's keys dated to the eighteenth century, one from the nineteenth century and three haversacks which had been uniform accessories of a well-known count's family. The family knew that the dress had been worn for the millennial events and that it had been made earlier, probably in the early nineteenth century when the family had been raised to the nobility by Emperor Francis I; it was customary to make a new court dress on ennoblement.

[ KATALIN DÓZSA ]

# An eighteenth-century Hungarian court dress with nineteenth-century alterations:

AN EXAMPLE OF HISTORICISM IN THE COLLECTIONS OF THE HUNGARIAN NATIONAL MUSEUM

## Description of the dress

The court dress consists of a skirt, a front-laced bodice (i.e. a bodice with a centre front opening secured with laces), and a stomacher (Inventory number: T. 1984. 259. 1-3.). Size: the bodice - 420 mm long; the stomacher - 410 mm; the skirt - 1170 mm. The fabric is made from a lampas silk woven with red, purple, white, golden and green silk and metal threads on a dark blue damask ground; bobbin lace made from golden metal thread; a machine-made imitation of this lace; and, a machine-embroidered cotton lace on a white tulle base. The lining is made

from coarse-textured linen in blue and ecru colours and a plain blue calico; the lacing is of golden spun braid. (Figs. 1-2).

The damask weave of the silk lampas has a pattern of a tiny garland of roses with a bow, arranged in tendrils; the pattern of the brocade is a meandering pattern of naturalistic flowers in a larger scale, with representations of roses in full bloom, rosebuds, rose-hips, and flowers resembling lilies and bluebells on leafy stems. One group of rosehips bends down from a branch in a triple cluster; the other group is arranged in the shape of pomegranates or pineapples in the centre of the repeat. (Figs. 12-13)

FIGURE 1 Dress, front  
(Inventory number: T.  
1984. 259. 1-3)



FIGURE 2 Dress, back  
(Inventory number: T.  
1984. 259. 1-3)



The golden bobbin lace has lobed borders with fan-like patterns. This lace is narrower, lighter in shade and has a matt sheen compared to the machine-made imitation, which also has lobed edges, a wavy pattern, a tripartite row of tulips and open-work squares. The white lace on the open-work tulle has patterns of scattered leaves and flowers. (Figs. 6-7)

In its present form, the cut of the dress is Hungarian style following the fashion of the late nineteenth century. The bodice is made of the blue silk stiffened with baleen ('whale-bone'), and its centre front point runs deep down into the skirt in the front. It is open in the front, and fastened with 11 pairs of gilt, eighteenth-century hooks and lacing. It is decorated with 4-4 golden-coloured open-work studs. There is a white lace ruffle around the neckline. Lace was used around the neckline and the lacing as appliqué, along the sides, following the cut, arranged in several vertical lines framed with machine-made golden lace. The back is almost completely covered in lace; the lace bands (which are probably of eighteenth-century date) are clearly visible in the centre part, particularly the lace band over the baleen stiffening (boning) running down the centre back (compare Figs. 3-5 with Figs. 6 and 7, and see comparison in Figure 9). The centre back ends in hooked suspenders with metal bracing. Under the lace-covered bodice there is a blue linen extension

but the original cut is recognisable. The rather puffed, white lace sleeves end in ruffles at the elbow. The stomacher is trapezoid in shape, with slightly arched sides; there is a white lace ruffle around the back of the neckline and golden lace appliqué around the front, with a similar golden lace braid at the bottom of the stomacher. The lining is made from coarse-textured *écru*-coloured linen; although the original boning had been removed, the inset breast pocket has been retained (Figs. 7-8).

The skirt was made from pieces, and was extended with pleats into a trapezoid shape below the waist. The floor-length skirt front is shorter than the back, which is closely pleated at the waist and it has a tail (train). There is a wide gold lace braid at the hem which conceals the blue calico extension to the original length of the skirt. There are traces of another pleating at the back.

The base fabric of the dress (i.e. the blue lampas) is from the middle of the eighteenth century but the place of manufacture is unknown. The meandering naturalistic floral patterns of the cloth suggest a relationship with Lyonnaise silks which were woven with large, naturalistic floral and fruit patterns, so-called 'floating' ornaments, in a finely shaded, tapestry-weaving-like three-dimensional form, from 1730 until about 1770.<sup>2</sup> This complicated and technically rather difficult procedure was facilitated by a series of



FIGURE 3 Bodice, spread out

FIGURE 4 Eighteenth century bodice (back) and stomacher (underside)

FIGURE 5 Eighteenth century bodice (front) and stomacher (front)

FIGURE 6 Dress, back, detail (Inventory number: T. 1984. 259. 1-3)

FIGURE 7 Stomacher, front (Inventory number: T. 1984. 259. 1-3)



FIGURE 8 Stomacher, showing hidden pocket (Inventory number: T. 1984. 259. 1-3)

FIGURE 9 Two bodices compared: T. 1984. 259. 1-3 on the left, and an eighteenth century bodice on the right

technical innovations, introduced mostly by the most famous weaver from Lyon, Jean Revel. The application of natural patterns was typical of his style. There are also some isolated patches of landscapes in a different proportion, including Chinese pagodas and columns decorated with garlands, among the shaded fruit and floral patterns imitating tapestry-weaving. Patterns without landscapes are typical of the period 1750-1760.<sup>3</sup>

Lyon dominated silk manufacture in the eighteenth century.<sup>4</sup> The designs were spectacular, varied and complicated, and the designers were well respected; some of the designs are still preserved. By 1759, 59 designers were working for the Lyonnaise silk weaver's workshops. Between 1730 and 1770, two design assortments per year were launched and sent to the royal courts of Europe, which meant plenty of orders for these silks. Nonetheless, demand outstripped supply and several high-quality manufacturers worked in Tours and Paris as well. Their patterns were copied and even improved, for example in Spitalfelds in London, England<sup>5</sup>, Berlin, Spain<sup>6</sup> and even in Austria. Hungarian silk weaving was stimulated by an embargo and protective tariffs imposed by Maria Theresa; these led to a remarkable development in the Austro-Hungarian weaving industry. If imports were prohibited and the silks were popular, we may suppose that the fabric was not made in France but in Austria; however there is no evidence to support this supposition.<sup>7</sup>

There are other court dresses cut in a similar Hungarian style in Hungarian collections. The most beautiful is probably the one worn by a female member of the Majtényi family in circa 1750 (Hungarian National Museum, inventory number 1935.109). It was sold to the museum in 1935 by Anna Muslay, wife of Rudolf Majtényi. 'The light blue, plain silk bodice is tightly braced with baleen, the front runs down into a gore on the skirt, it has a wide lacing, a round neckline, it is richly decorated with a 3-cm-wide gold lace. The yarn of the lacing is fastened by 15-15 silver hooks ... The fabric is sky-blue lampas silk' made in Lyon according to the Inventory, 'it is intertwined with silver, the naturalistic patterns are violet, pink, yellow and green bows arranged in three-dimensional, reticular tendrils'.<sup>8</sup> The apron and shirt of Malines with lace ornaments are modern additions 'made according to original pictures'<sup>9</sup> says the description by József Höllrigl at the first exhibition.

The two other Hungarian court dresses, made of lampas silk with blue, silver and coloured silk threads belong to the collections of the Hungarian Museum of Applied Arts (inventory number, 14954 a-b.) The bodices and skirts were made from identical



FIGURE 10 Eighteenth century stomacher



FIGURE 11 Blue linen pocket (Inventory number: T. 1984. 259. 1-3)

materials: a blue damask ground with floral patterns of large, colourful roses and carnations. The cut of the bodice is identical to that of the dress in the National Museum; it is bordered with silver hooks and gold bobbin lace with fan-like patterns. The

white lace around the neckline, as well as the baggy sleeves, are twentieth-century additions<sup>10</sup>, just like the nineteenth-century apron made from Brussels lace. It was probably exhibited in 1938; it can be identified as number 37 according to a very brief description but there are no pictures of it. At that time it was matched with a tulle apron made with silver embroidery in 1930.<sup>11</sup> There was another dress exhibit under number 35 in the collections of the Museum of Applied Arts, made in Hungarian fashion from blue damask and ornamental gold lace in the eighteenth century but it was mislaid during the Second world War. It is interesting to note that there is a bodice and stomacher made from lampas silk with floral patterns on a blue ground and bordered with gold lace in the Textile Collections of the Budapest History Museum.

## Court dress and its variants

The so-called *grand habit/costume de cour*, that is, a court dress worn for royal ceremonies originated during the reign of Louis XIV. In the French court, such dress was worn by a lady or gentleman who was to be introduced to the king. Ladies had to wear a bodice with a round neckline, elbow-length baggy sleeves and a skirt (*jupe*) with a detachable train (*manteau*) fastened over the skirt. At first such a dress had to be black when worn for an introduction, but as this attire was obligatory for every great ceremony of the court, the range of colours was extended to include red, blue, green, white, etc. The cut of the lady's dress lagged slightly behind current fashions. In the eighteenth century, panniers were worn under the skirt (*jupe*). In the middle of the eighteenth century, the skirt and the train were cut in one piece and the *robe de cour* or (*grand*) *robe à la française* as they were called, were made from silver or golden brocade, or were embroidered. In the late eighteenth century, the back part of the costume, often made of Lyonnaise silk with floral patterns (or its imitations), was often cut in 'sack-back' style, creating the so-called 'Watteau-folds'.

The historical Hungarian costume was created and became popular in the late sixteenth and early seventeenth centuries. Men's costume developed from the mixture of the styles of Eastern kaftan and trousers, and Western fashion, while female dresses combined the elements of Renaissance Italian, Spanish and German fashions.<sup>12</sup> The Hungarian dress was made up of a bodice, a skirt, baggy sleeves and an apron. In the seventeenth century, they were mostly made of embroidered silk or velvet; in the mid-eighteenth century, under the reign of Maria





FIGURE 12 The pattern of the silk (obverse) (Inventory number: T. 1984. 259. 1-3)



FIGURE 13 The pattern of the silk (reverse) (Inventory number: T. 1984. 259. 1-3)

Theresa, they were mostly made of golden-silver patterned lampas silk. They were worn primarily in Transylvania, but were also popular in the Felvidék (Upper Northern Hungary before 1920), and were also worn in the Habsburg Court on the most festive occasions. In 1711 the wearing of court dress for court situations was made obligatory by Charles VI, but the Hungarian-style dress was acceptable even then, so Hungarian magnates and noblemen usually stuck to it. Queen Maria Theresa was crowned wearing a Hungarian-style costume in Pozsony (today Bratislava, Slovakia). The young and beautiful queen was depicted in several pictures in a light blue silk dress woven with gold thread, which was hard to distinguish from the abundant gold lace, precious stones and pearls applied as ornaments to her dress. This style was modified in the nineteenth century to a form which is known as the *díszmagyar*, with false bodice, white tulle or lace sleeves on the bodice, lace apron, and a head-dress or bonnet to which a veil made from the fabric of the apron was fastened.

Hungarian noble ladies eagerly wore clothes made in the French fashion, both in the seventeenth and eighteenth centuries. A good example of this is a *robe à la française*<sup>13</sup> from circa 1760-70, from the Majtényi family which was worn by Anna Vay, wife of Gábor Muslay; she probably had it made when her husband was appointed as the vice-bailiff of Pest County in 1768. The dress was sold to the National Museum by Anna Muslay Majtényi in 1935 (inventory number; 1935.110.) and exhibited in 1938.<sup>14</sup> The dress is made of apple-green silk with lace motifs in green, white and pink silk thread in a wavy line in smaller and bigger lobed tendrils and garlands of flowers in the middle of the bigger lobes. It was decorated with green and pink chenille; the quilted white border was once covered in white lace. The bodice, which has a square neckline, reaches down into the skirt in a gore; it is open in the middle; is fastened with tiny buttons, covered in its own fabric. The double skirt is flat on the back and the front, wide on the sides; the inner skirt is shorter; the other one is open in the front, lengthened in an arch

backwards; it has a train. It has a 'sack-back' with pleats called Watteau-folds from the shoulder; the tight elbow-length sleeves end in a double ruffle.

This detailed description is justifiable because it facilitates comparison, but it is worth examining the *robe à la française* of the Musée Galliera mentioned above. It also has a 'sack-back' and is flat on the sides, but the skirt is pleated in the front, the laced bodice runs deep down into the skirt, the elbow-length sleeves are ruffled and the stomacher is decorated with gold lace ruffles in three rows.

A comparison of the two types of costume reveals similarities and differences. The bodice of the Hungarian dress is always sleeveless, the shirt underneath is always visible, the front is widely boned. It was often decorated with gold lace but it must have been taken from French fashion. The line of the bodice and the cut of the sleeves usually followed the fashion but the skirt did not, for it was usually evenly pleated and round. In the nineteenth century, the skirt was also adjusted to follow the French fashion which was not so difficult until the 1870s, as the richly pleated round skirts were similar to the Hungarian-style dresses, but they did not follow the fashion of tight dresses and bustles between 1870 and 1890. In 1896 the more densely pleated back with train was imitated as it only involved a slight difference from the Hungarian style. The constant features of Hungarian female court dress are the laced bodice, baggy sleeves and full skirts, but their fashionable cut makes them easy to date.

## Conclusions

In summary, we can say that the material of the dress, the stomacher, the hooks, the boning of the bodice and – last but not least – the skirt suspenders on the back are of eighteenth-century date. Comparison with an unaltered bodice makes the dating obvious. The skirt was altered to give it a fashionable cut in the 1890s but the original seam and traces of extensions are easily recognizable, which facilitates the 'reconstruction' of the first version. The gold lace is probably a good imitation of nineteenth-century date, although there are some areas of lace that must date to the eighteenth century.

It is clear that a typical Hungarian eighteenth-century court dress was altered very carefully, with the fewest possible changes, for its owner in 1896. Why did the collector think that the dress dated from the early nineteenth century? The family of the original owner traces its nobility back to the early nineteenth century, when one of their ancestors, a gallant Hussar captain, covered himself in glory in the Napoleonic

wars and therefore was raised to noble rank.<sup>15</sup> At the time he married into an ancient noble family, so the history of the dress can be easily followed. It is not impossible that someone from the wife's family had been introduced to Maria Theresa, on which occasion the dress was made and later on it was held in great regard and maintained with great care.

Finally, the following questions arise: why did the well-to-do lady of the family not order a new dress instead of modifying a garment from the family wardrobe? Why did she care so much about the cut of the dress? Why was the remodelling undertaken with such great care? First it has to be noted that the alteration is unlikely to have been done in order to save money. The history of Hungarian dress reflects the respect and maintenance of pieces of clothing inherited from ancestors: father to son; mother to daughter. The re-use of clothes held in respect by the family became more and more important from the second half of the nineteenth century because all the ancient garments, fabrics, buttons, laces, hooks and eyes proved the nobility and long history of a family. Thus families competed with one another: the more ancient dresses or accessories the better; an old garment meant more prestige for the owner than a new one. It is therefore quite understandable that the eighteenth-century dress was handled with the utmost care and that the eighteenth-century designs were preserved as much as possible.

Then came the final question: what to do with the costume? One suggestion was to reconstruct it to its original eighteenth-century form, to expand the number of valuable, ancient pieces, as both the original cut and alterations were visible. We realized, however, that we would not be able to reinstate or restore the original state of the Hungarian court dress completely and precisely. It would have been another twentieth-century alteration, a reconstruction to an eighteenth-century form that existed only in our heads. What is even more important, the alteration carried out in 1896 is an integral part of the costume's history and is a spectacular example of the cult of traditional styles.

## References

- Buzási, Enikő (Ed.). *Főúri ősgalériák, családi arcképek* [Aristocratic ancestors' galleries, family portraits]. Exhibition catalogue. Hungarian National Gallery. Budapest, 1988.
- Delpierre, Madelaine (Ed.) *Uniformes Civils français, cérémonie, circonstances 1750-1980*. Musée de la Mode et du Costume. Exhibition catalogue. Paris, 1982.
- Földi-Dózsa, Katalin. Die Ungarische Nationaltracht als Hofkleidung. In: *Kaiser und König*. Ausstellungskatalog. Collegium Hungaricum - Österreichisches Nationalbibliothek. Wien. 2201: 23-9.

- Földi-Dózsa, Katalin. *Le costume de cour de hongrois*. In: Exhibition catalogue. Musée Carnevalet. Paris, 2001: 73-80.
- Földi-Dózsa, Katalin. *Az udvari díszruha története. Tanulmányok Budapest Múltjából*. [The History of the Hungarian Court Court Dress. Studies from the Past of Budapest.] XXX. Budapest, 2001.
- Fülep, Ferenc (Ed.). *A Magyar Nemzeti Múzeum* [The Hungarian National Museum]. Budapest, 1977.
- Höllrigl József. *Magyar viselettörténeti kiállítás* [The History of Hungarian Costumes Exhibition] The Museum of Applied Arts, catalogue, Budapest, 1938.
- Join-Dieterle, Catherine; Horvat, Frank. *De la Mode et des Jardins*. Musée Galliera. Paris, 1997.
- Kugler, Georg; Kurzel-Runtscheiner, Monica. *Das Kaisers teure Kleider*. Ausstellungskatalog. Kunsthistorisches Museum. Wien, 2000.
- Markowsky, Barbara: *Siedengewebe*. Katalog des Kunstgewerbemuseum Köln. Band VIII. Köln, 1976.
- Modes & Révolutions*. Musée de la Mode et du Costume, Palais Galliera. Exhibition Catalogue, Paris, 1989.
- Morrall i Romeu, Eulalia; Segura i Mas, Anton. *La Seda en España, Leyenda, poder y realidad*. Barcelona, Madrid, Lunberg, 1991.
- Rothstein, Nathalie. *Silk Designs of the Eighteenth Century from the Collections of the Victoria and Albert Museum*. London, 1990.
- von Boehn, Max. *Die Mode. Menschen und Mode im achtzehnten Jahrhundert*. München, 1928.
- <sup>15</sup> The dress was sold by Borbála Piatsek, wife of János Nováky. In Iván Nagy: Magyarország családi címekkel [Hungarian Families and their Coats-of Arms] Vol. VIII: 169. János Nováky was mentioned in the census of Trencsén County between 1810 and 1830.

## Endnotes

- <sup>1</sup> The author worked for the textile collections of the Hungarian National Museum and was the manager of the collection between 1971 and 1994. She would like to thank Lilla Tompos, the current manager of the collection, for her kind contribution to this article.
- <sup>2</sup> A typical example: the material of a *robe à la française* made around 1750: écru, 1.208. The pattern was made by Jean Baptiste Chevillon, the design can be found in the Bibliothèque de France, Paris. See Join-Dieterle, C, and Horvat, F. 194. no.14. p.34: illustration.
- <sup>3</sup> Markowsky, 1676: 67.
- <sup>4</sup> See Join-Dieterle, C. and Horvat, F. Paris 1997: 31.
- <sup>5</sup> Rothstein, 1994.
- <sup>6</sup> A similar, salmon-coloured pattern with flowers and tendrils in a reticular arrangement on a floral patterned damask base can be found for example in the collections of the Museu Tèxtil de Terassa, Inventory number: 4564, size: 101 x 54 cm, see in: Morrall i Romeu and Segura i Mas, 1991 p.28. Cat.No.: 118, picture 129.
- <sup>7</sup> I have not seen any similar ones in the silk samples of the Museum für Angewandte Kunst.
- <sup>8</sup> Fülep, 1977. no. 86. pictures 200-1. Description provided by Mária V. Ember.
- <sup>9</sup> Höllrigl, 1938, 18, nos.3-4. illustration X.
- <sup>10</sup> Addition by Katalin E. Nagy.
- <sup>11</sup> Höllrigl, 1938: 19.
- <sup>12</sup> See References.
- <sup>13</sup> Fodor, I. and Cs. Lengyel B. (Eds.) Magyar Nemzeti Múzeum [The Hungarian National Museum] Budapest, 1992: 83. no. 99. The description, which is mostly identical with the one in the article, was made by the author.
- <sup>14</sup> Höllrigl, 1938: 18, no.32, illustration IX.

Dutch textile historians tend to associate black clothing with the culture of the seventeenth-century regents.<sup>1</sup> The Dutch 'golden age' flashes upon the eye in black worsted costumes and silk velvet waistcoats with bright, white starched millstone-like collars. Was this ceremonial black costume an old tradition? Is there any relation to the Dutch Calvinistic burgher society? Or is it just an impression one gets from the Dutch paintings and not really representative of the habits of a seventeenth-century Dutchman? Medieval men and women are depicted in colourful clothing. Red and bright green colours were often used, and of course blue in innumerable shades.<sup>2</sup> Yet, seventeenth-century people seem to love bright and often brilliantly coloured clothing, as well. This love for colours expresses itself in the bright colours in tapestries but also in the many recipes for dyeing bright red, orange, yellow, lilac, etc. Still, black textiles occur abundantly in clothing, not only in the fine black cloth of the governing circles, but also in many other textiles for everyday use. Through the many recipes in a seventeenth-century recipe book from Haarlem in Holland, I would like to show how important black dyeing was in the seventeenth century.<sup>3</sup> Thereafter, dyeing methods, including the dyestuffs and necessary auxiliaries, and the consequences of their use in black dyeing, are discussed.

JUDITH H. HOFENK DE GRAAFF

## Dyeing black in seventeenth-century Holland

### The 'Haarlem' manuscript

The Frans Hals Museum in Haarlem owns a number of manuscripts related to the city's textile industry. One of these is a large manuscript with recipes for textile dyeing. Although it has never been published, it was studied at the end of the nineteenth century (in 1888), probably by the archivist of the municipal public record office. The first page bears the title: *'Receptenboek om allerlei kleuren te verwen, afkomstig uit een Haarlemse ververij'*<sup>4</sup> 'Recipe book for Haarlem'. The author is unknown, but the manuscript must date from the second half of the seventeenth century. This dating is based on annotations and literature mentioned with the recipes. The

regulations introduced for the French textile industry from 1669 by the French minister of Louis XVI, Jean Louis Colbert, are cited many times.<sup>5</sup>

The manuscript consists of about 900 pages of recipes, mostly for dyeing textiles, but recipes for artists' pigments are included as well. The manuscript has three parts. The first part of about 300 pages is a haphazard gathering of all sorts of recipes and notations in different languages: Dutch, French and Latin. The second part, about 550 pages, is in alphabetical order according to colour; the final part of about 20 pages seems to be in a different handwriting and contains only recipes for dyeing textiles.

The first two parts of the manuscript are the most interesting. Every recipe or citation has an

abbreviation of the reference to its origin. The annotations represent three different sorts of sources. First there are recipes copied from contemporary printed books. The best known of these international sources are: *l'Instruction Général* by Colbert and the *Kunstbuck* by Alexias Piedemontanus.<sup>6</sup> Some recipes are copied in the language of origin; others are summarized in Dutch.<sup>7</sup> There are also citations from a dyer's book printed in Dutch, by Gerbrandus Nicolai, 1648, which is not only mentioned in this manuscript but also in a contemporary manuscript of Jacoba van Veen.<sup>8</sup>

The second type of source is manuscripts by contemporary dyers, e.g. '*Een invetie door Sr. Jan Janse Tromp my bekend gemaakt*' - 'An invention made known to me by Mr Jan Janse Tromp'.<sup>9</sup> Oral communication is a third source of information. Examples of this type are: 'Mr Daniel Tau Lober, merchant at Rotterdam, says that his father-in-law, by the name of Belle, is a hatter and for dyeing his hats, he uses ...' and '... a certain woman said to me that her Master, a hatter, dyed his hats apple blossom colour using blue litmus and sumac'. From some recipes it becomes clear that the author of the manuscript has asked colleagues to give a demonstration of a particular dyeing method as applied by themselves. It is clear that he pays for the demonstration and for writing down the recipe.

From the wording of the recipes it seems that the anonymous author must have been a professional dyer. Under the heading 'blue', descriptions are given of the successive steps in an indigo dyeing process. In the margin are remarks made about the success of the colour obtained and about difficulties that arose. Sometimes the customer's name is mentioned, and also how much was dyed and at what price, and whether it was successful. From this one might conclude that the author was a blue dyer or the owner of a blue dyer's workshop.

### Black in relation to other colours

From the content of the alphabetical part of the manuscript one can see how important - compared to the other colours - was the dyeing of black. The colours taking most of the pages are black (92), blue (82), and red (64). However, this partition does not give a completely honest representation of the colours in use. To the number of recipes ranged under the heading 'red' (64), the recipes ranged under the headings: 'Kuffelaer' (13) and 'crimson' (46) could be added.<sup>10</sup> Counted in this way, the order of importance would be: red (113), black (92) and blue (82). From these figures black seems to appear to be more important than blue.

It might be asked whether this preference for black has to do with fashion or if the price of black dyeing might play a role. Much is still unknown about the prices for dyeing and it would require a separate study to explain the differences. Some conclusions can be drawn on the basis of the price of the raw materials and the difficulty and duration of the dyeing process. If dyeing black is performed without a blue 'ground', then it is certainly cheaper than dyeing blue. To dye blue, woad or indigo was used in the seventeenth century. In the period in which the Haarlem manuscript was written - the third part of the seventeenth century - mainly indigo was used. Indigo had to be imported from the Far East or from the West Indies and was relatively expensive. The ingredients for black dyeing - gallnut or alder bark - could be imported but were also available within the country. The process of blue dyeing with woad or indigo - both vat dyestuffs - was more complicated and laborious than dyeing with black gallnut or alder bark - both mordant dyes. If a blue 'ground' was used for dyeing black, the total price must have been higher than for just dyeing blue. This calculation already leads to the conclusion that different qualities of black can be expected.

## Woollen cloth and silk

As mentioned above, there are two ways of obtaining a black colour on textiles: a) dyeing dark blue with woad or indigo and a second dyeing with madder on an alum mordant; and, b) mordanting with an iron compound and dyeing with a tannin-containing plant material (gallnut, alder bark or sumac). The dyeing of black with gallnut and iron sulphate was often forbidden for good quality woollen cloth; yet, recipes for such dyeing nevertheless already existed in the early sixteenth century. The earliest source with recipes for dyeing black on silk is '*T Bouck va Wondre*' from 1513, which is written in Dutch. This book is not a real dye book but more a collection of recipes that fall within the scope of a 'book of secrets'. Together with many others, several recipes for dyeing silk and wool are present; of these, four are recipes for dyeing black. Three of these are for dyeing silk cloth or velvet; one is for dyeing yarn. The ingredients in this recipe are the following: gallnut, swarf and filings from iron, copper red (iron(II) sulphate) and gum Arabic.<sup>11</sup>

In the Netherlands - in the main dyeing centres such as Amsterdam, Haarlem and Leiden - municipal regulations were applied primarily to the dyeing of woollen cloth and silk. Other products, such as

ribbons, embroidery threads, linen yarns and linen or cotton fabrics, were exempt from the regulations. In the Northern Netherlands, the quality of the dyeing of high quality woollen cloth (which was meant for export) was regulated in detail.<sup>12</sup> In the first part of the seventeenth century, the city regulations required that black be obtained by a first dyeing of dark blue with indigo or woad and a second dyeing with madder on the basis of an alum mordant. This kind of black might have had a reddish hue. There were, however, differences in approach to the use of dye products under discussion between the important dye centres. As early as 1588 dyers at Leiden asked the local government for permission to dye woollen cloth 'in the Amsterdam manner', i.e. with gallnut and iron sulphate. However, the city syndics (Staalmeesters), using the argument that the quality of this black was insufficient, rebuffed this request. The colourfastness of the black dyed with woad or indigo in combination with madder was excellent.<sup>13</sup>

The Haarlem manuscript contains several recipes for dyeing black where the starting point is a cloth already dyed blue. For instance: 'to make good black on the ground of a large double blue sample or on an "old" blue sample or on a single blue sample'. After that the following ingredients are mentioned: sumac, gallnut, madder and logwood. Then copperas is used as the iron compound (Haarlem manuscript 310/r/2). The expression 'blue double sample' refers to the quality system where every year the depth of the blue dyeing was determined by the city government. This was expressed in dyed samples, which were kept in the clothmakers' hall and against which all the blue dyed cloth had to be checked.

The other way of dyeing black was the combination of a tannin-containing plant extract, such as gallnut, together with an iron salt. This iron salt, green vitriol – also called copperas, a name formerly applied to all the vitriols – is iron(II)sulphate. In the period mentioned above, black dyeing of woollen cloth with gallnut and iron(II)sulphate was prohibited but this changed during the course of the seventeenth century. In the second half of the century the use of gallnut and iron salts prevailed, whether or not on a blue 'ground'.<sup>14</sup> This black has a more blueish-black hue. The quality depends very much on the ingredients used. It could be relatively good if the proper ingredients were used. The use of alder bark and iron filings for high quality cloth, for example, was still explicitly prohibited.<sup>15</sup> By the end of the seventeenth century, the change from a dyeing method with a combination of indigo and madder into a method with gallnut and iron sulphate had taken place. At that time a differentiation was also made in the type of black woollen cloth: black and 'kastoorzwart'

(castor black). In the recipes one can read that a good quality black woollen cloth was given a blue 'ground' with indigo followed by black dyeing with gallnut, alder bark or sumac and iron compound. However, the castor black was dyed directly on the white wool using a tanning agent such as gallnut or alder bark and an iron salt. Thus at that time a combination of a tanning substance and an iron compound as a mordant was frequently used as a method for the black dyeing of wool as well as silk.

For silk dyeing the situation was different. From antiquity the method most used was a combination of tannin products and iron compounds. In the early sixteenth century it was already permitted to dye silk with gallnut and copperas; this is in contrast to the dyeing of black on wool. In the Netherlands the silk industry commenced in the early seventeenth century, and Amsterdam and Haarlem were the most important cities for its development. The Dutch East India Company (VOC) imported raw silk, in the form of silk cocoons or skeins of raw yarns, from Persia and India. Regulations for silk dyeing were limited and introduced later. They were explicitly focused on the weighting of silk, the dyeing of black and the dyeing of red (crimson).<sup>16</sup>

From very early times silk was weighted with tannin products. For many purposes the raw silk had to be degummed (removing the resinous product which glues the two silk filaments together). Through this degumming process the silk lost approximately 25% of its weight. To increase the weight again and to give the silk a better drape it was treated, for example with gallnut. Another possibility was the use of sumac. In the case of dyeing black, the weighting and black colouring took place in one process. As this process could be repeated several times to increase the weight of the silk, strict regulations governed the amount of weight increase that was permitted. The quality and durability depends much on the amount of extra weight given to the fibres. If the weighting was more than 50% of the original weight of the silk, the silk fibres became brittle and less durable.<sup>17</sup>

In the Amsterdam ordinance of 1607 the traditional way of dyeing silk black with gallnut is already confirmed. In a contract by a 'black dyer' the materials necessary to start a dye workshop are mentioned. The usual dyestuffs, such as gallnut, sumac and copperas, are mentioned. It seems that the ordinances were often violated and in a later ordinance of 1626 it is even forbidden for a black dyer to store alder bark and swarf in the workshop. In the same ordinance it is permitted to treat the silk once with gallnut, but it is explicitly forbidden to repeat this even once or twice.<sup>18</sup> Looking at the recipes in the Haarlem manuscript one gets the impression that

the alder bark vat is the most important part in the dyeing process. In almost all cases the alder bark vat is combined with a separate dyeing with gallnut and also copperas is used together with the alder bark vat. This combination is used for fabrics as well as for yarns. A typical recipe for black yarns, taken from the Haarlem manuscript, shows the typical ingredients but also the complexity of the process:

**For black silk yarns:** If one wants to boil down for black one must take for 70 pounds of silk 28 pounds of soap. However the soap must not be added before the water boils. Then put the soap in the boiling water and boil the solution until the soap is completely dissolved. Put then silk in the soap and let it boil for one hour. After that take it from the kettle with a stick and lay it on the grid [mesh] and leave it to drain well. Then take the yarn out of the sacks, wring them and rinse them thoroughly. After rinsing take 1 pound of alum and dissolve this in a small kettle and pour this in a barrel. In this put the silk for a quarter of an hour and wring it well and rinse well again. After this wring the silk well with a wringing stick and put it on a bench until all the silk has been wrung well. Then put all together in the kettle with gall and leave it there for 34 hours and wring it again and put them on sticks. When all the silk is on sticks then divide them in four sections and hang them in the rack, two above and two below. Now, before going to dye one takes a kettle with rainwater and adds 4 pound of gum (Arabic). Let this dissolve well, but keep stirring to prevent the burning of the gum. After dissolving add this solution to the black kettle and one must add: 7 pounds of copperas, 1 pound of swarf, 2 pounds of syrup and then one can dye the silk. Take every hour one portion. When the dyeing is finished then one must put the silk in the rinsing tub and rinse well. Wring them well and rinse again twice and let them rest in the kettle for a quarter of an hour and rinse again. After this rinsing one must wring it with a stick, put them on sticks and dry. This is good quality black.

To prepare a black kettle. Put canal water (Burgwalswater) in a kettle, bring this to boiling, take then 10 pounds of copperas, 5 pounds of gum, 2 pounds of swarf, 3 pounds of 'syrup' put this in the kettle and stir well and thereof one must boil a 'beveret'. To make 'beveret'; one must take 1 pound crushed gallnut, 4 'loot' (? ounce = ca. 15 grams) of fenugreek, 6 'loot' flee seed, pomegranate skins, 1 'loot' oregano, 8 'loot' alder bark, 16 'loot' swarf and half a pint of brandy, stir well and work as you must. (Haarlem manuscript 322/r/1-324/l/1)

In this recipe the term 'beveret' requires some explanation. The ingredients are of two kinds: the iron particles and iron sulphate on one side, and ingredients of organic nature on the other. The organic ingredients will ferment and produce organic acids, which in turn will react with the iron compound to form iron acetate, formiate, etc. to bring the iron into solution. After being dissolved it can react with the tannin compounds in gallnut and sumac to form the black iron tannate. Another, shorter and more straightforward recipe from the same manuscript is the following:

**Black silk:** The first day when the silk is taken from the gallnut bath one must put them on sticks, when the kettle is hot then put in it the first morning: 4 pounds of gum and 3 pounds of copperas. In the afternoon put in 2.5 pounds of gum and 3.5 pounds of copperas. Then again 3 times the same. Then in the evening rinse in a barrel with water and leave it for the next day. In the morning add 3.5 pounds of gum and 1.5 pounds of copperas. In the afternoon add again 2 pounds of gum and copperas, then rinse again as before; the next day take 2 pounds of gum and 3 pounds of copperas. In the afternoon again add 1.5 gum and 2.5 pounds of copperas. After this the silk is good, then being rinsed and rubbed. To finish the black silk after it has been dyed black and rinsed well it is very beautiful (Haarlem manuscript 320/1/2)

As can be seen above, the recipes are often very complicated and many ingredients, such as gallnut and alder bark and sumac together with yellow wood (fustic), alum, madder, tartar, orpiment, and gum arabic are added. The importance of thoroughly rinsing after the dyeing process is emphasized. Although recipes can be found for silk fabrics, such as satin and velvet, most describe the dyeing of yarns.

## Other textile products

So far only black dyeing of wool and silk has been mentioned, because much of it is known through printed regulations and decrees. The regulations particularly focused on the dyeing of woollen cloth in all varieties and on silk materials. However, in these only the permitted or prohibited ingredients are mentioned. Dyeing methods or special requirements for the dyeing of other textile products are not mentioned. Hence, these seem to be free from regulations. The Haarlem manuscript provides a better view on the seventeenth-century dyeing methods and on the variation of textile products to be dyed. The recipes apply to a range of textile materials, including silk yarns, ribbons, apron cloth and linen. Textiles mentioned are woollen cloth of

second quality, serge, camlet, woollen, cotton, linen and silk yarns and mixed fabrics of wool and silk. Another example from the Haarlem manuscript is for so-called 'Turkish serge'

**Black Turkish serge:** For six pieces. Bark, one basket, madder six pounds, let it boil for one quarter of an hour, then put the six pieces in this bath and let it boil for one and a half-hour. Take it out and let it cool off. Then take twenty-eight or thirty buckets from your dye bath. Take copperas nine pound, gum four pounds, madder one pound, swarf a scoop, province wood (logwood) one pound and let this boil together, then put your six pieces in the liquid and stir well to prevent them to burn and leave them one hour. Take your material out, let it cool off and repeat the process twice. After that rinse well. (Haarlem manuscript, 293/L/3)

There are also recipes for a rich variety of linen cloth, fustian, stockings, hats, and wool fibres, the finishing of silk textiles and for the degumming of raw silk. Recipes for dyeing 120 pairs of stockings and for only a few pairs both occur. There are also recipes for aprons and work clothes and for blue linen, both in small and in large quantities and for large amounts of trimmings. A most peculiar recipe, but typical for the Haarlem manuscript, is the following one for dyeing black hats.

**To blacken hats:** For 12 buckets liquid, take two 'loot' mercury sublimate, and put that in a cup of brandy, and leave it for two hours, and the mercury will be solved properly.<sup>19</sup> This I have heard from a hatter in Utrecht, and he put this to the gall liquid and to the logwood during the boiling liquid. For the second time in the black liquid he add copperas, also two 'loot' Spanish green, and after boiling for two hours he takes it out. For the last time in the black liquid he does not put in 'beveret' in the kettle, but boils his hats again one hour in the same liquid and then in warm water very well washed and rinsed, this will become very good black (Haarlem manuscript, 310/r/l).

The most important ingredients in all these recipes for black are the alder bark vat, iron filings and copperas.<sup>20</sup> Many of these ingredients are often used in combination. The frequent use of logwood for the dyeing of linen textiles is striking. In many city regulations this dyestuff is forbidden for woollen cloth.<sup>21</sup> In the Amsterdam decrees for dyeing woollen cloth this dyestuff is explicitly prohibited. It comes on the market under the name of province wood or Campeche wood. From the recipes in the Haarlem manuscript it seems to be used frequently. The importance of the use of dyewoods such as logwood and brazilwood is expressed in the Amsterdam gov-

ernment's monopoly of grinding the wood logs in the city prison (rasphuis). The dyewoods were imported in the form of logs and had to be splintered for grinding (raspen).<sup>22</sup> As a specific example, a recipe for the black dyeing of linen is quoted from the Haarlem manuscript; this recipe would not have been allowed for woollen cloth. The recipe is rephrased and translated:

**Black, linen or yarn:** Fill a vat with alder bark and pour water on it. Leave it for a month. Take a bucket of swarf and two pounds of filings and add it to the vat. Leave it for a fortnight. Drain the liquid regularly through a tap from the lower part of the vat and pour it back into the vat. Take one pound of gallnut for dyeing six pounds of linen and boil them. Put the linen in this liquid and leave it for one hour. Wring out the linen well, drain the dye from the bark vat in a tub and put the linen in it for two hours. Wring the linen out and put it again into the hot gallnut extract. Leave it for an hour, wring it out again and put it for another two hours into the liquid from the vat. This procedure is carried on until the linen is sufficiently black. (Haarlem manuscript, 294/1/3).

Once again this recipe shows the combination of different tanning substances (gallnut and alder bark) and iron compounds (swarf and filings).

## Chintzes and other printed textiles

For the printing of black patterns on cotton, mainly the dark contour lines of a pattern, comparable ingredients are used as for dyeing wool and silk. In printing, the cotton fabric is pre-treated with an extract of gallnut and after that it is printed with a solution of an iron compound (iron liquid). Dissolving copperas in water made this 'iron liquid' but also the liquid from the alder bark vat as previously described was used for this purpose.<sup>23</sup> The Haarlem recipe book does not contain any descriptions for printing cotton fabrics (chintzes). Although much chintz was already produced in The Netherlands in the seventeenth century, this printing seems to be done by another group of craftsmen.

## Chemical principles of the dyeing method

Like many other natural dyestuffs, those mostly used for dyeing and printing black belong to the group of mordant dyes. The chemical principle of these is the bonding of the (organic) dyestuff molecule to a metal to form an insoluble complex that is physically and chemically connected to the textile fibre. The bonding to wool and silk (protein fibres) is easier than to linen and cotton (cellulose fibres). The fastness to light and washing of dyed cellulose fibres



is less than that of wool and silk. In black dyeing the dye molecule consists of tannic acid and the metal involved is iron. The dye complex is iron (III) tannate. The colouring matter, tannic acid, occurs in various plants. Gallnuts, mentioned in many recipes, are the most important source for tannic acid. They came mainly from the East Indies, Persia and the Levant. The Aleppo gallnuts belong to the top quality, containing 50-60% of tannic acid. Other brands came from Smyrna, Hungary and Austria.

The second most often used source of tannic acid is alder bark. In some recipes oak bark is given as a replacement. Both materials contain various sorts of tannic acids which are chemically not completely identical, but which produce a similar black colour with iron salts. Alder bark was mostly used for the bark vat, as it appears in recipes from Amsterdam, Haarlem and Leiden. The third important tanning substance is sumac. In seventeenth-century Dutch recipes it is often called 'smack'. It consists of the finely ground leaves of the *Rhus coriaria L.*, a native bush in Europe. It is sometimes called Sicilian sumac, which clearly refers to its origin.<sup>24</sup>

The iron compound mostly used is copperas, a mineral with the composition of iron (II) sulphate, which could also be produced by heating mixtures that contained both iron and sulphur. After dissolving the reaction product and evaporation of the water, the iron (II) sulphate was left as a residue. Relevant supplies came from Italy, Hungary and Saxony. In lists of imported and exported merchandise copperas is explicitly mentioned in the chapter on 'Dyes for all sorts of Colours/materials and ingredients'.<sup>25</sup> Two other sources for iron compounds are mentioned frequently in recipes: swarf and iron filings. In dyeing black the weighting of silk and the dyeing take place simultaneously.

The weighting of silk was generally carried out by means of an extract of gallnut, alder bark or sumac. For those silk materials that were meant to be dyed in light colour, gallnut was used. For others, sumac was allowed. This is because the weighting with gallnut did not colour the silk too much whereas the weighting with sumac gave it a yellowish hue. The addition of an iron compound produced the black iron tannate. This form of weighting must not be confused with the methods of weighting used in the nineteenth century. By then, apart from iron compounds, tin-silicate compounds were used, which had a much more negative effect on the quality and the durability of black silk than the gallnut weighting.<sup>26</sup>

## Consequences of black dyeing

Almost every textile conservator is confronted with the problem of deteriorated black textiles, e.g. in

the black silk in tapestries and embroideries, but sometimes also black parts in chintzes and other printed textiles. The brittle black-silk fabrics of nineteenth-century costumes are a well-known problem. As already indicated, the process of black dyeing and weighting applied in the second half of the nineteenth century is totally different and the causes of deterioration are different as well. Although the causes of the degradation by tin/silicate weighting have been subject to research, results so far have not shed enough light on this matter.<sup>27</sup> In the present paper I will limit myself to black dyeing with tannin substances together with iron compounds.

So far we have seen that there was no one single method for dyeing black with a tannin product and an iron compound. There were great differences in quality of the basic ingredients and in the execution of the dyeing process. On the one hand this was determined by local regulations; on the other hand, the price of the product played an important role when no regulations applied. Cheaper products were often dyed with dye materials of lesser quality. The dyeing of linen and cotton yarns and fabrics was not regulated at all, and the proper dyeing was left to the dyer's craftsmanship and honesty. This difference also shows in the condition of the textiles that are preserved in Dutch museums. Many of the woollen and silk garments dating before the nineteenth century are in relatively good condition. However, one should keep in mind that the textiles in the museums mostly come from the richer part of the population and that very little will be left of cheaper clothing, such as work dress.

It is with good reason that municipal regulations objected to the use of swarf and iron filings. These consist of iron particles of different size, which can harm textile fibres with their sharp edges and are contaminated with impurities, such as sand particles. For dyeing, the iron particles first have to be converted into iron ions before the iron can react with the tannic acid. In the description of the alder bark vat, one can see that the iron tannate is already partly formed in the vat. In the dyeing process iron ions are attached to the fibre and there react with the tannic acid to form the insoluble iron tannate. Remains of iron swarf and filings will stay behind between the fibres depending on the amount of iron particles in the dye bath and the thoroughness of the rinsing process after dyeing. Black silk thread - even in more expensive tapestries or embroideries - is more often deteriorated. This might be due to the dyeing method, as the production of this type of yarn was not controlled by city regulations. It might also be due to the quality of the silk used for the yarns.<sup>28</sup> The same is true for ribbons and trimmings for which production was also not regulated.

The mechanism of degradation caused by the combination of a tanning substance and an iron compound has been studied extensively in the case of iron-gall ink corrosion on paper. Although there are also degradation phenomena in black textiles, there are important differences between the use of iron gall ink on paper and black dyeing of textiles. However, chemically the same processes take place. The degradation is caused by hydrolysis due to acidic components and by oxidation catalyzed by the free iron (II) ions. The great difference between the use of ink and dyeing lies in the method of application. For iron-gall ink the two ingredients - tannic acid and iron sulphate - are brought together and then applied after the compound has been formed. The ink as it is applied on paper contains the already formed black iron tannate, sulphuric acid - the result of the chemical process of forming the iron tannate-, free tannic acid and often an excess of iron sulphate. In the degradation of paper all these ingredients, but particularly the sulphuric acid, play an important role. However, in the textile dyeing process the mordant - the iron compound - is first applied and after that - in a separate process - the tannic acid is applied upon which the black colour is formed. After the dyeing process the textile is rinsed thoroughly. Although a relatively large amount of acid is formed during the dyeing process - and sometimes extra acidic matter is added - the acid is rinsed out subsequently. The quality and the durability of the textile product is therefore largely dependent on careful rinsing. One may conclude that the degradation of black textiles is caused mainly by oxidation, initiated by remains of the iron (II) compounds and less by acidic hydrolysis because the sulphuric acid is removed by the rinsing process. It is, however, possible that iron tannate, on deterioration, decomposes into tannic acid and iron ions, which could cause both hydrolysis and oxidation. The degradation of iron tannate is enhanced by unfavourable storage conditions (too moist). In addition to the dyeing process, the type of fibre material is also a factor in degradation. Linen and cotton are more susceptible to acid hydrolysis than wool and silk. However, wool is much more stable than silk.

## Conclusions

In the seventeenth century, woollen cloth of good quality was dyed black by a combination of indigo and madder. In the course of that century there was a shift towards a combination of indigo and gallnut with an iron sulphate or directly without blue ground with gallnut and iron sulphate (castor black). A combination of tannic acid extracted from gallnut and an iron sulphate was used to dye silk black. There were strict

regulations for good quality textiles made from wool and silk. For black dyeing of linen, trimmings, and embroidery yarns, etc., various combinations were used that were prohibited for dyeing woollen cloth. Tannic acid extracted from different plants, such as alder bark and sumac, were used in combination with various iron products, such as iron swarf and iron filings. For these textiles the alder bark vat was mostly used. Logwood seems to have been used frequently as well. This dyeing practice was not regulated.

The degradation of black textiles is for the greater part determined by the quality of the dyeing process. There will be little degradation where pure ingredients were used for textile materials with good ageing properties, as in woollen cloth. Silk fabric from the seventeenth and eighteenth century also has a good chance of being in good condition, although silk is more vulnerable than wool. Embroidery yarns, trimmings and silk yarns for tapestries were not subject to regulations, so there is a bigger chance that a cheap and thus poor-quality dyeing process was used. This shows from the material condition of textile museum objects. Chintzes from both India and Europe (and other cotton prints made in the same technique) follow the same pattern of deterioration. Here, too, the quality of the dyers' work plays a crucial role.

## Endnotes

- 1 Groeneweg, I., 'Over zwarte kleding in de gouden eeuw en een langdurig misverstand'. *Jaarboek 1999. Stichting Textielcommissie Nederland*, Amsterdam 1999: 10-26.
- 2 Heidi Nixdorf, Heide Müller, *Weisse Westen - Rote Roben; Von Farbordnungen des Mittelalters zum individuellen Farbgeschmack*. Berlin 1983.
- 3 Table of contents of the 'Haarlem' manuscript:
 

| Colour and page number     |    |                   |    |
|----------------------------|----|-------------------|----|
| Albus (white)              | 11 | Lavender (blue)   | 1  |
| Akker (pink)               | 4  | Lijfverf (pink)   | 1  |
| Amarant                    | 1  | Isabelle (brown)  | 1  |
| Appelbloesem (pink)        | 2  | Mantel (brown)    | 1  |
| Aurora (gold)              | 1  | Maijt (purple)    | 1  |
| Bierenbroot (beige)        | 1  | Minime (red)      | 1  |
| Spillebont Bisschops (red) | 1  | Moreel (brown)    | 1  |
| Blau (blue)                | 82 | Muscus (tellow)   | 3  |
| Cameel (camel)             | 1  | Nage (yellow)     | 1  |
| Carstaigne (brown)         | 1  | Oranje (orange)   | 11 |
| Cancel (yellow)            | 1  | Pavel             | -  |
| Citroen (yellow)           | 1  | Rassen&Velours    | -  |
| Colombin (beige)           | 1  | Pavonacuy         | -  |
| De Feu (red)               | 4  | Peers (violet)    | 4  |
| Feulje morte               | 4  | Pensee (violet)   | -  |
| Geel (yellow)              | 30 | Peerl (silver)    | -  |
| Gember (yellow)            | -  | Prince (red)      | -  |
| Gout (gold)                | -  | Purper (purple)   | 13 |
| Girja/grauw (grey)         | 22 | Roggebrot (brown) | -  |

|                    |    |                      |    |
|--------------------|----|----------------------|----|
| Groen (green)      | 7  | Rosen couleur (pink) | -  |
| Hair (brown)       | 2  | Rosen root (pink)    | 11 |
| Groen (green)      | 8  | De Roije (red)       | 2  |
| Jansgolij (yellow) | 1  | Rosijne (brown)      | -  |
| Incarnat (pink)    | 12 | Root (red)           | 64 |
| Isabelle (brown)   | -  | Swart (black)        | 92 |
| Kermosijn (red)    | 46 | Taneet (purple)      | 13 |
| Kuffelaars (red)   | 13 | Violet (violet)      | 13 |
| Lever (brown)      | 3  |                      |    |

- 4 On the first page of the manuscript with dye recipes a former researcher has written the following text 'the pieces of paper which are put between the pages are provided with a date which is mentioned in the text on that particular page'. The colours are dealt with in alphabetical order. On the first page of the manuscript the following text can be read: Recipe book to dye all colours, originating from a dye work in Haarlem dating from the second part of the 17<sup>th</sup> century. This book belonged to the dye works of Jan de Breuk & zoon te Haarlem, silk dyers, whose dye works were closed down in 1875. The name of the author is not known. However, he must have lived in Haarlem because of a note in which it is written that a 'painter' lived near the Bekenestenkerk. To the town of Haarlem 1888.'

The author of this article has numbered the pages of the manuscript, where the verso side of the page received the letter 'l' and the recto side the letter 'r'. On every page the recipes or notation was numbered in their order. This means that the first recipe on the recto side of page 294 received the notation: 294/r/1.

- 5 Colbert, J.L., *L' instruction général pour la teinture des laines et des manufactures de laine de toute nuance et pour la culture des drogues ou ingrédients qu'on emploie*, Paris 1671.
- 6 Alexias Piedemontanus, *Kunstbuck des Wolerfarmen hern*; A.P. Benutzte Übersetzung des Italienischen Originals: von H.J. Wecker, Basel 1575.
- 7 The recipes in the manuscript, which are taken from the 'Instruction général' by Colbert, are provided with the captions and recipe number. By comparing these numbers with the original source from the seventeenth century it is possible to verify whether the text is taken literally or is a summary.
- 8 Peek, Marja; de Boer, Hayo, Books of secrets: Methods of research into original sources on art technology, - in: *Contributions of the Central Research Laboratory to the field of conservation and restoration*. - Amsterdam: CL, 1994: 9-20.
- 9 Recipe number 302B/r/1.
- 10 In the seventeenth century the discovery was made of how to mordant with a tin salt to obtain a more brilliant red colour with cochineal. Cornelis Drebbel and his father-in-law Kuffelaer where the first to employ this method. This red was therefor also called 'Kuffelaer'. The word 'crimson' is often used for cochineal on a tin mordant. See also; Nie, W.I.J. de, *De ontwikkeling der Noord-Nederlandsche Textielververij van de veertiende tot da achttiende eeuw*. Leiden 1937: 165-77.
- 11 Frencken, H.G.T., 'T Bouck va Wondre (1513), Roermond 1934.
- 12 Posthumus, N.W., *Bronnen tot de Geschiedenis van de Leidsche Textielnijverheid*, 's-Gravenhage 1912.
- 13 Hofenk de Graaff, J.H., *Geschiedenis van de Textieltechniek - Lakennijverheid - Sitsen - Zijde-industrie*, Amsterdam 1992.
- 14 Hofenk de Graaff, J.H., Veranderend kleurstofgebruik in Leiden in de zestiende en zeventiende eeuw. *Textiel-historische Bijdragen* 36 (1966) 5-20.
- 15 Alder bark and oak bark contain various types of tannins, which are chemically related and form a comparable black colour with iron salts. To prepare the alder bark vat in the way it is utilized in Amsterdam and Leiden, alder bark is mainly used. Swarf is the residual product from the grinding of knives and scissors. In addition to iron particles it also contains sand and other contaminants. This might be the reason that swarf was forbidden frequently because it could damage the fibres. The iron particles will be converted into iron oxide in the dyestuff solution and, by adding vinegar, into iron (II) acetate. In this form it can be bound to the textile fibre. The recipe also mentions iron filings, a coarser product. The iron particles are a bit larger in this product and even more dangerous for the fibres.
- 16 Ordinance for the dyeing of silk in Amsterdam, August 1626 in Noordkerk. Handvesten II, 1151.
- 17 Silk containing sericin is called raw silk. The gum-like substance, affording protection during processing, is usually retained until the yarn or fabric stage and is removed by boiling the silk in soap and water, leaving it soft and lustrous, with weight reduced by as much as 30 per cent. Silk is sometimes treated with a finishing substance in a process called 'weighting'. Until the second part of the nineteenth century this was done with tannin products, such as gallnut and sumac with or without metallic salts. Later on, the tin/silica process was used to increase weight, add density, and improve draping quality. See Hofenk de Graaff, J.H., 'De Verzwaring van zijde, oorzaak en gevolg', in: *Zijde en Kunstzijde*, Textieldag 6 September 1990, Amsterdam 1992: 17-29.
- 18 Hofenk de Graaff, op.cit. 189-90. In the margin of the recipe the author has made a note which refers to Robertus Boyle, *Experimenta et considerationes de coloribus*, 1671.
- 19 Swarf, iron filings and copperas are iron compounds. The grinding of knives produces swarf and iron filings. Copperas is a mineral and contains iron (II) sulphate.
- 20 Logwood comes from the tree *Haematoxylum campechianum* L. and was imported from Latin America together with brazilwood in the seventeenth century. See Schweppe, H., *Handbuch der Naturfarbstoffe Vorkommen - Verwendung - Nachweis*, Landsberg 1992.
- 21 Hallema, A., De gevangenisarbeid in concurrentie met het particulier bedrijfsleven en de strijd om het Amsterdamsche tuchthuismonopolie ten tijde der Republiek, *Economisch-Historisch Jaarboek XIX* 1935: 114-201.
- 22 Hofenk de Graaff op.cit. 93-110
- 23 Hofenk de Graaff, J.H., *Natural Dyestuffs, Origin, Chemical Composition, Identification*, ICOM Committee for Conservation 'Madrid 1969.
- 24 'Lijste van de Rechten van Inkomen en Uxtgaen op de Koopmanschappen, Manufacturen en Waren, 21 dec. 1680. Na de Copie van Brussel, in's Gravenhage, Bij Paulus Schelters, ordinaris, Drucker van de Hoogh. Mog. Heeren Staten Generaal der Vereenighde Nederlanden 1706'.
- 25 Hofenk de Graaff, J.H., 'De Verzwaring van zijde, oorzaak en gevolg', in: *Zijde en Kunstzijde*, Textieldag 6 September 1990, Amsterdam 1992: 17-29.
- 26 Van Oosten, T., Investigation into the degradation of weighted silk, in: *Contributions of the Central Research Laboratory to the field of conservation and restoration*. - Amsterdam: CL, 1994: 65-76.
- 27 In the northern Netherlands tapestry weaving was not regulated; this contrasts with the situation in the southern Netherlands where both the weaving and the dyestuffs were strictly regulated.
- 28 Hofenk de Graaff, J.H. 'Färben und Schreiben. Verwendung und Schädwirkung von Farbmitteln auf Basis von Eisengallusverbindungen auf Textil und Papier. Ein Vergleich', in: *Tintenfrassschäden und ihre Behandlung*, Stuttgart 1999: 77-87.

The article is a revised version of a lecture given at the Textieldag 'Zwart' [Black] and is published in Dutch in *Jaarboek* 1999, Stichting Textielcommissie Nederland, Amsterdam 1999.

Translations of the Haarlem mss are the author's own.

The conservation of metal threads and particularly their cleaning presents a special difficulty for textile conservators. The established methods of cleaning metal objects, such as the use of polishing powders or the chemical removal of the stains or corrosion products from the surface, in most cases cannot be applied to textiles containing metal threads. These methods can be detrimental not only for the materials of the metal threads, the solid strips or wires made from several metal layers or the strips made from metal coated organic materials, but also for the fibrous core (on which the strips or wires are often wound) or the cloth itself.

[ MÁRTA JÁRÓ ]

# Metal thread variations and materials:

SIMPLE METHODS OF PRE-TREATMENT IDENTIFICATION FOR HISTORICAL TEXTILES<sup>1</sup>

## Review of the results and completed methodology of analysis

**T**hus, any cleaning or treatment of the textiles with metal threads has to be preceded not only by the investigation of materials of the textile itself (threads and dyes) but also by the identification of the morphology (shape and structure) as well as the material of the metal threads. In most cases morphological and material analyses can be easily carried out if we only need information before choosing cleaning method or to prepare documentation, e.g. whether there was a fibrous core used, or the strip is a combination of metal and organic materials, what the ground material is, etc. However, more accurate data on manufacturing technique, such as the materials of the metal layers in the layered strips and wires, the method of metal plating or metal coating of organic supports, the composition of alloys, can be obtained only through instrumental analyses. The latter group of information might be needed primarily in the detailed technical description of textiles (e.g. in catalogues),

and in the identification process with regard to the date and place of origin, or in comparative analyses.

The following paper describes and discusses the varieties of metal threads in terms of the materials and the combinations of materials used in making them, as well as the different kinds of information given by simple morphological and material analyses, and it outlines the opportunities and limits of these investigations.

## Morphology and materials of metal threads

### Morphology of metal threads

The morphological classifications and descriptions of metal threads have been discussed previously by many experts.<sup>2</sup> Metal threads can have several types of structures but basically they are made up of two units: 1. strips, i.e. solid metal strips or metal coated

strips made of organic materials; 2. solid metal wires. They have been used separately, but especially in the case of strips it has been more common to wind them around a fibrous core (yarn), or they have been made into more complicated metal thread structures.<sup>3</sup> The macro-morphological structure of metal threads (the kind of elements used and how they were produced from these elements, e.g. solid metal strip wound around a fibrous core in S-twist) can be determined by a simple magnifying glass or a binocular microscope. These investigations are usually done before treatment as part of the assessment of the state of preservation of the textile by the conservators, and the result is usually included in the conservation documentation. The micro-morphological features (evidences of the manufacturing technique or of the state of preservation of the thread on the surface or on the edge of the metal strip) can be detected in most cases with a scanning electron microscope at high magnification.<sup>4</sup> The macro- and micro-morphological investigations will not be dealt with in the following paper.

## Materials used to make metal threads

To date, the different materials used in making metal threads have been identified as:

- metals to make the solid strips, wires or metal coatings: gold, silver, copper and the alloys of these metals, zinc and nickel as alloying elements, tin and aluminium;
- organic materials used as support: leather, parchment (?), animal gut (membrane), paper and synthetic materials, such as Cellophane, cellulose acetate butyrate, polyesters;
- organic materials used as lacquer layer: egg-white, polyvinyl chloride, polyvinyl acetate;
- fibres used as core: silk, cotton, linen, viscose and some other not yet identified cellulose materials, wool and animal hair;
- metals used as ‘non fibrous’, metallic core: copper and copper alloys, iron.

## Classification of strips and wires the metal threads are fabricated from, according to the materials used to make them

For both a simple and a full-scale investigation of the manufacturing technique of metal threads and for the relevant interpretation of data coming from

the analyses it is essential to know the materials and combinations of materials to be encountered. To date, around 60 metal thread variations are known.<sup>5</sup> They differ in: their morphology; the colour and material of the fibrous core; the composition of metal(s), the organic media, lacquers, etc. Further analyses will probably reveal more variations. What follows is a discussion of the main groups of metal threads (identified by now), classified according to their materials in order to make it easier to identify them; sketches of the layer structures (if any) of the strips are provided.

### Gold and gold alloys

1. Strips and wires made of gold or gold alloys

### Silver and silver alloys

2. Strips and wires made of silver or silver alloys

### Gilt silver

3. Strips made of single-sided gilt silver (Fig. 1.)



FIGURE 1 Layer structure of the single-sided gilt silver strip

4. Strips made of double-sided gilt silver (Fig. 2.) and gilt silver wires



FIGURE 2 Layer structure of the double-sided gilt silver strip

### Copper and copper alloys

5. Strips made of copper or copper alloys (except for brass, see below)

### Copper with noble metal/s or brass coating

6. Strips made of double-sided gilt copper or copper alloys (Fig. 3.)

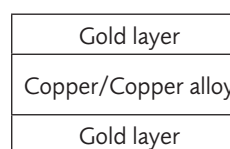

Fig. 3 Layer structure of the double-sided gilt copper strip

7. Strips made of double-sided silver-plated copper or copper alloys (Fig. 4.) and silver-plated copper wires

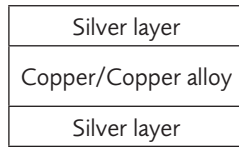

FIGURE 4 Layer structure of the double-sided silver-plated copper strip

8. Strips made of single-sided gilt, silver-plated copper alloy (Fig. 5.)

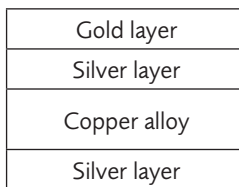

FIGURE 5 Layer structure of the single-sided gilt, silver-plated strip made of copper alloy

9. Strips made of silver gilt (double-sided silver-plated and then gilt) copper (Fig. 6.) and silver-gilt copper wire

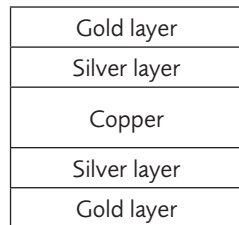

FIGURE 6 Layer structure of the silver gilt copper strip

10. Strips made of brass-plated(?) or cemented copper (Fig. 7.)

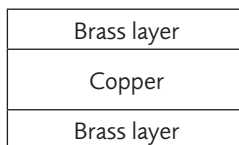

FIGURE 7 Layer structure of the brass-plated or cemented copper strip

11. Strips made of double-sided gilt, cemented copper (Fig. 8.)

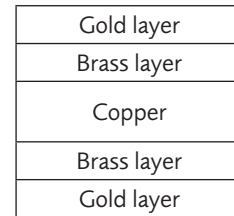

FIGURE 8 Layer structure of the double-sided gilt, cemented copper strip

### Brass

12. Strips and wires made of brass

### Metal-coated leather

13. Strips made of single-sided gilt (gilding with gold, gold alloys or gilt silver leaf) leather (Fig. 9.)

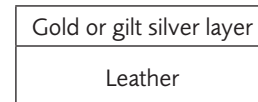

FIGURE 9 Layer structure of the single-sided gilt leather strip

14. Strips made of single-sided silver-coated leather (Fig. 10.)

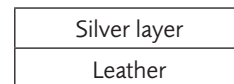

FIGURE 10 Layer structure of the single-sided silver-coated leather strip

15. Strips made of single-sided silver-coated, then lacquered leather (Fig. 11.)

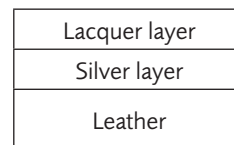

FIGURE 11 Layer structure of the single-sided silver-coated then lacquered leather strip

16. Strips made of one side gilt, reverse side silver-coated leather (Fig. 12.)



FIGURE 12 Layer structure of the one side gilt, reverse side silver-coated leather strip

20. Strips made of single-sided gilt paper strip with preparation layer (bole or lacquer) under the gilding (Fig. 16.)

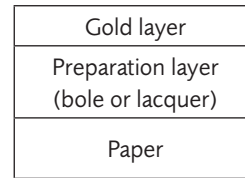

FIGURE 16 Layer structure of the single-sided gilt paper strip with preparation layer under the gilding

### Metal-coated animal membrane

17. Strips made of single-sided silver-coated animal membrane strip (Fig. 13.)

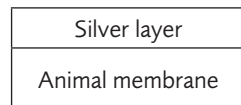

FIGURE 13 Layer structure of the single-sided silver-coated animal membrane strip

21. Strips made of single-sided silver-coated paper strip with preparation layer (bole or lacquer) under the silver (Fig. 17.)

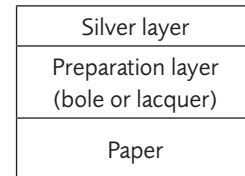

FIGURE 17 Layer structure of the single-sided silver-coated paper strip with preparation layer under the silver

18. Strips made of single-sided silver gilt (one side coated with gilt silver leaf), animal membrane strip (Fig. 14.)

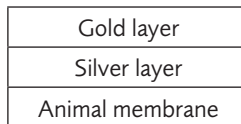

FIGURE 14 Layer structure of the single-sided silver gilt animal membrane strip

22. Strips made of single-sided tin-coated paper strip (Fig. 18.)

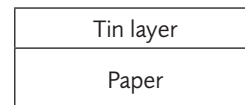

FIGURE 18 Layer structure of the single-sided tin-plated paper strip

### Metal-coated paper

19. Strips made of single-sided gilt paper strip (Fig. 15.)

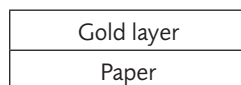

FIGURE 15 Layer structure of the single-sided gilt paper strip

### Laminated aluminium

23. Strips made of aluminium foil sandwiched between two (in some cases coloured) Cellophane films (Fig. 19.)

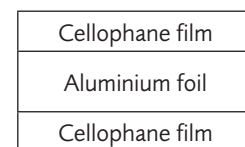

FIGURE 19 Layer structure of strip made of aluminium foil sandwiched between two Cellophane films

24. Strips made of polyester film vacuum-plated on one side with aluminium, coated on both sides with (in some cases coloured) lacquer layer (Fig. 20.)

|                     |
|---------------------|
| Lacquer layer       |
| Vaporized aluminium |
| Polyester film      |
| Lacquer layer       |

FIGURE 20 Layer structure of the strip made of polyester film vacuum-plated on one side with aluminium, coated on both sides with lacquer layer

25. Strips made of polyester film vacuum-plated on both sides with aluminium, coated on both sides with (in some cases coloured) lacquer layer (Fig. 21.)

|                     |
|---------------------|
| Lacquer layer       |
| Vaporized aluminium |
| Polyester film      |
| Vaporized aluminium |
| Lacquer layer       |

FIGURE 21 Layer structure of the strip made of polyester film vacuum-plated on both sides with aluminium, coated on both sides with lacquer layer

## Simple identification of the base material of solid metal strips and wires made from metal-coated organic materials used in metal thread making: investigations with microscopy and chemical methods

This part deals with the quick identification of the most frequently used materials of solid metal strips, wires, and metal-coated organic strips in metal thread production.

As the first step of the analyses by optical microscopy, the colour of the metal surface is examined. The second step is to establish whether the strip is made of solid metal or cut from metal-coated organic material. In case of solid metal strips and wires the third step is the identification of the base material and the metal coating (if any) with simple chemical tests, taking into consideration the results of the previous analyses by optical microscopy.

Mechanical or chemical cleaning methods are rarely applied in case of metal-coated organic materials<sup>6</sup> so normally it is sufficient to identify the presence of an organic support material; however further details can be useful for the documentation. With the help of an optical microscope the type of the organic support material can be determined in most cases. The identification process is completed with chemical tests. The synthetic materials can only be differentiated using instrumental analyses. Sophisticated methods of investigation have to be used, in most cases, for the identification of the materials of the metal-coating or the lacquer layers, if any. The colour of the metal layer, however, can give some information on the metal used for coating the organic support. The information gathered from the analyses by optical microscopy and the simple chemical tests can be of help in choosing an appropriate cleaning method and prepare the conservation documentation of the metal threaded textile. Some parts of the simple metal thread analysis have been discussed above<sup>7</sup>, but for good measure the whole procedure of the investigation is given as follows.

### Sampling, size, storage and transport of the samples

To carry out the analyses, a small amount (about 5 mm long) of sample is needed. Naturally the more samples we have, the more 'comfortable' our work is and the results are the more reliable.

For the most convenient storage and transport of the samples, small glass tubes with a cork or small envelopes made of synthetic material are suggested. The use of adhesive tape, folded paper, glass sheets or sheets made of synthetic material held together with adhesive tape, is not recommended, as the sample may stick onto the surface of the material during opening and can not be removed without damage.

### Examination of the samples under a microscope

After the morphological analyses, the metal threads are undone into the basic elements if they are made of strips or wires wound around a fibrous core or if they are of an even more complicated structure. For further investigations the strips and wires are used.



The examinations can be carried out with the help of optical microscopy in reflected light at a magnification of 15-25 times.

### Observation of the colour of the metal surface - preliminary identification of the metal/s present

If we examine the colour of the metal surface of the strips or wires or of the corrosion products on them with an optical microscope, we can obtain information not only on the state of preservation of the material, but also on the metal used. The most frequent metal and corrosion product colours

observed in case of metal threads are summarized in Table 1.

### Observation of the colour and transparency of the organic support: preliminary identification of the material type

As stated earlier, the identification of materials in the case of metal-coated organic strips is important first of all for the technical documentation of the textile.

The colour and morphology of the underside of the strip (if it is not lacquered or covered with

TABLE 1 State of preservation and colour of the metal surface and the resulting conclusions

|   | State of preservation and colour of the metal surface*                                                                                                   | Probably used metals or metal combinations**                                                                                                                                                                                                                                                 |
|---|----------------------------------------------------------------------------------------------------------------------------------------------------------|----------------------------------------------------------------------------------------------------------------------------------------------------------------------------------------------------------------------------------------------------------------------------------------------|
| A | Well preserved, <i>gold-looking, shiny surface</i>                                                                                                       | Gold (1), gilt silver (3, 4), gilt copper (6), silver gilt copper (8, 9), gilt, cemented copper (11), brass (12), brass-coated copper (10), gilt leather (13, 16), gilt paper (19, 20), laminated aluminium (yellow coloration) (23, 24, 25)                                                 |
| B | <i>Tarnished (matt), gold-looking surface</i>                                                                                                            | Gilt silver (3, 4), gilt copper (6), silver gilt copper (8, 9), gilt, cemented copper (11), brass (12), brass-coated copper (10), gilt leather (gilding with gold alloy or gilt silver leaf)(13), silver-coated leather (with yellowish lacquer layer)(15), silver gilt animal membrane (18) |
| C | Partly corroded, <i>gold-looking, shiny surface with black spots</i> (corrosion products)                                                                | Gilt silver (3, 4), gilt copper (6), silver gilt copper (8, 9), gilt, cemented copper (11), brass (12), brass-coated copper (10), gilt leather (gilding with gold alloy or gilt silver leaf) (13)                                                                                            |
| D | Partly corroded, <i>gold-looking, shiny surface with greenish spots</i> (corrosion products)                                                             | Gilt copper (6), silver gilt copper (8, 9), gilt, cemented copper (11), brass (12), brass-coated copper (10)                                                                                                                                                                                 |
| E | Slightly corroded, <i>purple coloured, shiny surface</i>                                                                                                 | Gold (alloyed with a large amount of silver: electron) (1), silver gilt animal membrane (18)                                                                                                                                                                                                 |
| F | Well preserved, <i>silvery, shiny surface</i>                                                                                                            | Silver (2), silver-plated copper (7), silver-coated leather (14, 15), laminated aluminium (23, 24, 25)                                                                                                                                                                                       |
| G | <i>Tarnished (matt), greyish surface</i>                                                                                                                 | Silver (2), silver-plated copper (7), silver-coated leather (14, 15), silver-coated animal membrane (17), silver-coated paper (21), tin-coated paper (22)                                                                                                                                    |
| H | Well preserved, <i>reddish, shiny surface</i>                                                                                                            | laminated aluminium (red coloration) (23, 24, 25)                                                                                                                                                                                                                                            |
| I | <i>Tarnished, reddish surface</i>                                                                                                                        | Copper (5)                                                                                                                                                                                                                                                                                   |
| J | Partly corroded, <i>reddish surface with green and/or blue spots</i> (corrosion products)                                                                | Copper (5)                                                                                                                                                                                                                                                                                   |
| K | Corroded surface, <i>light or dark grey coloured corrosion products</i> (the metal is transformed into corrosion product/s on the surface or completely) | Silver (2), gilt silver (3, 4), silver-plated copper (7), silver gilt copper (8, 9), silver-coated leather (14, 15), silver-coated animal membrane (17), silver-coated paper (21), tin-coated paper (22)                                                                                     |
| L | Corroded surface, <i>black corrosion products</i> (the metal is transformed into corrosion product/s on the surface or completely)                       | Silver (2), gilt silver (3, 4), copper (5), silver-plated copper (7), silver gilt copper (8, 9), silver-coated leather (14, 15), silver-coated animal membrane (17), silver gilt animal membrane (18), silver-coated paper (21)                                                              |
| M | Corroded surface, <i>green and/or blue corrosion products</i> (the metal is transformed into corrosion product/s on the surface or completely)           | Copper (5), silver-plated copper (7), silver gilt copper (8, 9), gilt, cemented copper (11), brass (12), brass-coated copper (10)                                                                                                                                                            |
| N | Well preserved, green-, blue-, pink, etc. coloured metallic surface                                                                                      | Laminated aluminium (different coloration) (23, 24, 25)                                                                                                                                                                                                                                      |

\* For more information on the corrosion products on the surface of metal threads see in: Á. Timár-Balászy and D. Eastop op.cit.: 135-7.

\*\* The numbers in parentheses refer to the groups of materials discussed in the introduction

metal) can be of help in distinguishing between paper, leather, membrane and synthetic materials:

- Paper is usually white or yellowish.
- Leather is coloured yellowish, brownish, sometimes dark brown on the surface as well as on the cross section of the strip.
- Synthetic materials appear translucent when the lacquer and aluminium layers are scraped off.
- Animal membrane is translucent and much thinner than paper, leather or synthetic materials used as supports.

For further examination, a staining test can be carried out to distinguish between paper and leather (see below). Of course, the variety of the employed raw materials and manufacturing techniques, the degradation of the organic materials, the deterioration of the threads during use or previous treatment can sometimes make the identification uncertain.<sup>8</sup>

### Burning test

If the results of the optical microscopy are ambiguous and we cannot decide if the strip is made from solid metal or a metal coated organic material, a small quantity of the sample should be lit (put in a flame) – the solid metal strip will only change its colour while the sample from an organic support material will partly burn or shrink.

### Analysis of well preserved, tarnished or partly corroded, solid metal strips and wires

After the preliminary analyses by optical microscopy, the samples in good condition or which are slightly corroded (groups A, B, C, D, E, F, G, H, I, or J in

Table 1) are mounted on a microscope slide or on a ceramic sample holder and 1-2 drops of nitric acid solution in 1:1 dilution are added.<sup>9</sup> The examinations are carried out under an optical microscope, in reflected light, at a x25 magnification. Solution is accompanied with the appearance of tiny bubbles. Depending on the process of dissolution (Table 2, column 1) a few drops of different reagents are added to the solution. The possible results and conclusions are summarized in Table 2.

If we compare the results of the examinations with the analysis of the colours (Table 1.) we are given a series of information on the base material of the metal strip or wire or even the metal coating. Further information, e.g. about the alloys or the presence of a silver layer on the copper base under the gold layer can be gathered with simple wet analytical examinations only if we use large quantities of samples and only after a long procedure.

### Analysis of solid metal strips and wires covered with corrosion products

If the surface of the sample is covered with corrosion products (but the metal probably has not yet completely transformed into a compound), according to the results of optical microscopy it belongs to groups K, L, or M of Table 1, the first step is to dissolve the corrosion products from the surface using a ‘Silver Dip’ (thiocarbamide in acidic solution).<sup>10</sup> 1-2 drops are applied to the sample and carefully warmed up (e.g. with a hairdryer). After dissolving the corrosion products the samples are carefully blotted with filter-paper. 1-2 drops of

TABLE 2 The investigations and conclusions of the ‘wet’ analyses of the slightly or not corroded metal samples

| Chemical process while dissolving the samples                                                                                                                                          | Further reactions                                                               | Results                                                                        |
|----------------------------------------------------------------------------------------------------------------------------------------------------------------------------------------|---------------------------------------------------------------------------------|--------------------------------------------------------------------------------|
| Sample would not dissolve                                                                                                                                                              | -                                                                               | gold or gold alloy                                                             |
| Sample dissolves, solution is transparent, colourless                                                                                                                                  | + 1 drop of 10% sodium-chloride solution (common salt) * - <i>white residue</i> | silver or silver alloy                                                         |
| Sample partly dissolves, there are more bubbles on one side than on the other, solution is colourless, transparent, there are some gold remains in solution (in case of strips)        | + 1 drop of 10% sodium-chloride - <i>white residue</i>                          | silver strip gilt on one side (single-sided gilt silver)                       |
| Sample dissolves partly and slowly, in strips bubbles appear first on edges, solution is colourless, transparent, there are some wrapping-like gold remains (both in strips and wires) | + 1 drop of 10% sodium-chloride solution - <i>white residue</i>                 | silver strip gilt on both sides (double-sided gilt silver) or gilt silver wire |
| Sample dissolves, solution turns green, it is transparent                                                                                                                              |                                                                                 | copper or copper alloy (brass)                                                 |
| Sample dissolves partly, solution turns green, it is transparent, some wrapping-like gold remains (in strips and wires)                                                                |                                                                                 | gilt copper, silver gilt copper, cemented and gilt copper                      |

\* The preparation of the solution: dissolve 10 g of sodium-chloride in 50 ml of distilled water and dilute it to 100 ml.

distilled water are added to them, then the 'rinsings' are removed with filter-paper. Afterwards we proceed according to Table 2.

### Analysis of solid metal threads completely transformed into corrosion products

In case of completely corroded metal threads (groups K, L and M in Table 1) the colour of the sample can help to identify the base metal. In certain cases the presence of gold coating can be confirmed with a solubility test:

- If the metal has transformed into a thick grey, greyish-black or black corrosion product, we may try to use an acidic thiocarbamide solution. If, after the sample has dissolved, some gold flakes remain in the colourless solution, the strip or wire was made of gilt silver.
- If the metal has transformed into green corrosion products, we may use a 10%-nitric acid as solvent.<sup>11</sup> If, after the dissolution of the sample, some gold flakes remain in the green solution, the copper or copper based strip or wire was coated with gold.

### Staining test of the organic support material – confirming the use of leather support on the basis of tanning method

In the case of leather supports, chemical tests can be carried out to reveal whether the leather was vegetable tanned or not. After staining the sample with ammonium iron sulphate solution, a deep blue-black coloration indicates the presence of tannic acid in the leather.<sup>12</sup> In the case of blackened, deteriorated leather samples this test does not work. The results of previous investigations show that the leather threads were made of vegetable tanned leather. Thus, if the material of the organic support darkens, it is definitely made of leather. If the test has failed, the material is probably paper or parchment, or even some kind of non vegetable-tanned leather but this is unlikely given the previous results.

### Analysis of the metal coating on organic support material

The identification of the material of the metal coating on the organic support may be necessary for the preparation of the technical documentation of the textile. If the coating is yellow, shiny, resembling gold, we may carry out a solubility test to justify the presence of gold (Table 2, row 1.). The other metal coatings (silver, gilt silver, gold and silver, tin, aluminium) normally cannot be identified with certainty with wet analytical methods due to the

scarcity and condition of the metal (its transformation into corrosion products).

## Conclusions

The conservation-restoration of metal threaded textiles has to be preceded by a morphological and material analysis of the metal threads. Sophisticated methods are used to study the manufacturing technique of metal threads, but before treatment a quick test can be carried out to choose an appropriate method. This quick analysis involves determining the morphology with a binocular microscope and identifying of the base metal and gilding with chemical tests.

For cleaning metal-threaded textiles, a wide variety of mechanical and chemical methods are used. As described above, all these methods have advantages and drawbacks. Using dry methods (abrasives) will remove not only dirt and corrosion products from the surface of the metal, but also thin coatings and some metal as well. The fibrous core and the organic support can be damaged. The corrosion rate of some metals increases using wet methods. If the pH of the solution is not neutral, we can damage the fibrous core and the surrounding fabric.

The cleaning of textiles with metal threads is always a compromise. Knowing the fabric and the materials of the metal thread helps us choose the least harmful method.

## Endnotes

- <sup>1</sup> Our first test series was developed for the international courses for textile restorers organized by Ágnes Timár-Balázs (1989 and 1994 in Budapest, Hungary). This article is partly based on the unpublished text of the author's contribution presented in the Abegg-Stiftung at the Ehemaligentreffen (meeting of ex-students and teachers), Riggisberg, Switzerland in 1996. A Hungarian version was published in 1997: Járó M.: Fémfonalak készítőtechnikájának gyors meghatározása a textília tisztítása előtt [Quick identification of manufacturing techniques for metal threads prior to the cleaning of textiles] In: *Múzeumi Műtárgyvédelem*, 24 (1995). Budapest, 1997: 91-100. A short summary of the simple analysis methods was published in Chapter 23.2. of the book: *Chemical Principles of Textile Conservation* by Á. Timár-Balázs and D. Eastop, Oxford, 1998: 409-411.
- <sup>2</sup> For example: Hoke, E., Pertraschek-Heim: Microprobe analysis of gilded silver threads from mediaeval textiles, *Studies in Conservation*, 22 (1977): 49-62.; Járó M.: The technological and analytical examination of metal threads on old textiles. In: *4<sup>th</sup> International Restorer Seminar, Veszprém*, 1983. Budapest, 1984, Vol. II: 253-264.; Indictor, N., Koestler, R. J., Wypyski, M., Wardwell, A.: Metal threads made of proteinaceous substrates examined by scanning electron microscopy - energy dispersive X-ray spectrometry, *Studies in Conservation*, 34 (1989): 171-182.

- <sup>3</sup> For example: Tóth A., Járó M.: Untersuchung der Goldfäden einer ungarischen Prunksatteldecke aus dem 16. Jahrhundert, *Restauratorenblätter*, 13 (1992): 65-68.; Járó, M., Tóth, A., Kiss-Bendefy, M.: Investigation of metal threads and metallic decorations of a 16<sup>th</sup> century bonnet. In: *International Perspectives of Textile Conservation 1995-98*, eds.: Á. Timár-Balázs, D. Eastop. Papers from the ICOM CC Textiles Working Group Meetings, Amsterdam 13-14 October 1994 and Budapest 11-15 September 1995, London: 127-132.
- <sup>4</sup> For example: Hardin, I.R., Duffield, F.J., Characterization of Metallic Yarns in Historic Persian Textiles by Microanalysis. In: Needles, H.L., (ed.), Zeronian, Haig, S. (ed.), *Historic Textiles and Paper Materials – Conservation and Characterization, Advances in Chemistry Series 212*, Washington D.C., 1986: 231-252.; Indictor, N., Koestler, R.J., Blair, C., Wardwell, A.: The Evaluation of Metal Wrappings from Medieval Textiles Using Scanning Electron Microscopy and Energy Dispersive X-ray Spectrometry, *Textile History*, 19 (1) (1988): 3-22.; Járó M., Gondár E., Tóth A.: Technical revolutions in producing gold threads used for European textile decoration. In: *Antiquités Nationales, Mémoire 2*. Saint-Germain-en-Laye, 1993: 119-124.
- <sup>5</sup> Járó M.: Metal Threads in Historical Textiles. Results and further aims of scientific investigations in Hungary in: *Molecular and Structural Archaeology: Cosmetic and Therapeutic Chemicals*, eds.: Tsoucaris, G. and Lipkowski, J., NATO Science Series, Kluwer Academic Publishers, 2003, 163-78.
- <sup>6</sup> See a summary of cleaning methods in Chapter 14 in Á. Timár-Balázs and D. Eastop op.cit., 242-48.
- <sup>7</sup> See Notes 1
- <sup>8</sup> Indictor, N., Koestler, R. J., Wypyski, M., Wardwell, A.: Metal threads made of proteinaceous substrates examined by scanning electron microscopy - energy dispersive X-ray spectrometry, *Studies in Conservation*, 34/1989: 171-82.
- <sup>9</sup> To prepare the solution, add one unit of concentrated nitric acid to the same quantity of distilled water and mix it together – the solution is extremely corrosive!
- <sup>10</sup> To prepare the solution: measure 10 g of thiocarbamide and 30 g of tartaric acid and dissolve them in 50 ml of distilled water. After complete dissolution dilute it to 100 ml. It is an extremely acidulous solution!
- <sup>11</sup> To prepare the solution: carefully drip 11 ml of concentrated nitric acid (64 w/w %) into 50 ml of distilled water, then dilute it to 100 ml.
- <sup>12</sup> Mihályffy L.: *Bőripari laboratóriumi gyakorlatok* (Laboratory exercises in leather industry) Könyvüipari Kiadó, Budapest, 1953

Few of the many trials and experiments in cleaning historic, tarnished gilt and silver embroidery or brocades have given due consideration to the textile components present, usually silk or other fibre cores of wrapped metal threads, silk and linen couching threads and support fabrics. Threads and fabrics alike are susceptible to stains as well as to mechanical and chemical damage when conventional cleaning methods have been used, yet this correlation has not been discussed in the extensive literature on the topic.

[ KATIA JOHANSEN ]

## Assessing the risk of wet-cleaning metal threads

### Research project

A research project of 2.5 months' duration in 1999 for three conservators, funded by the Danish Ministry of Culture, aimed to determine the feasibility of electrolyte cleaning of corroded gilt and silver threads on museum textiles. The focus was on objects in which metal threads are an integral part of the fabric and can not be removed for cleaning (as for example braid and fringes often can). The primary concern of the study was how the silk cores of the metal threads are affected by the proposed chemical solutions; the state of the silk cores in metal embroidery and brocades does not yet seem to have been investigated systematically in conjunction with cleaning. A promising new variation of a locally applied electrolytic method was chosen for study because of the minimal mechanical stress to the embroidery and apparently minimal amount of water needed. However, in the course of the study, it became apparent that substantial amounts

of water were necessary to monitor the electrolytic process, thus negating this method's primary attraction regarding preservation of the silk. (Regarding method and trial results, see Stemann Petersen and Taarnskov 2001). Here, primarily the mechanical factors involved in assessing the risk of a wet cleaning are considered; these are important regardless of the chemical composition of any electrolyte or other aqueous solution. All textile conservators have observed how lightweight silks are stiffened after a wet treatment.

Water on silk is not necessarily detrimental in itself, but silk core fibres of metal threads - more or less trapped in a tightly wrapped casing of sharp-edged metal - can be expected to be damaged by the swelling (about 30% by volume) and shrinking involved in getting wet and subsequent drying *under tension*. The following aspects were considered as parameters for judging which factors might apply in evaluating whether a wet cleaning would in itself damage the core fibres.

## Silk

In conservation literature's descriptions of metal embroidery, the fibre core's colour and twist are sometimes indicated, but there is rarely a description of the core's state of preservation. This is unfortunate, since the well-being of these threads ultimately determines the survival of the metal embroidery, whether it is corroded or not. If the core disintegrates, nothing will be left but a multitude of tiny spirals of metal thread – on the floor. Neither has the well-being of couching threads apparently ever been commented upon, although if they disintegrate, the entire embroidery also falls apart. When the thin silk warp threads holding metal threads in place in heavy brocades begin to break, the whole pattern is affected, disappearing gradually or rapidly, leaving only stiff metal thread ends sticking out in all directions.

In the royal costumes from the 1600s preserved at Rosenborg Castle, silk is always the base material for embroidery, a component material in brocades, stitching threads and core material for wound metal threads. The presence of other textile fibres such as cotton, linen, and wool is negligible, thus the importance of investigating silk for this collection.

Silk is a filament produced by insect (moth) larvae to form a cocoon. Wild silk (tussah) is less uniform than cultivated silk, and seems not to have been used for the silk fabrics and threads in the fashionable and sophisticated fabrics and embroidery in the Rosenborg collection. Cultivated silk is smooth and lustrous both as fibre, thread, and cloth. Silk fibres measure 15-25 microns in diameter and can be 40,000 m long, though only 600-900 meters are reelable (Mauersberger 1947; Ryder and Gabra-Sanders 1985). Silk threads used in weaving and embroidery can be unspun (floss), spun (twisted) and/or plied. That the technology of making the silk thread upon which the metal strips are wound is rarely considered is borne out by the fact that conservators have not yet adopted universally accepted designations for the integral parts of a spun or unspun, plied or unplied thread; this alone can be the reason that conservators rarely describe the threads' construction. In order to describe the problems facing a wrapped thread, it is imperative that the threads' constituent parts be recognized, identified, and described. To do so requires the correct terminology; suggestions are given below. In case of doubt, it may be necessary, as always, to draw a picture.

Culling CIETA's *Vocabulary of Technical Terms* (1964) for pertinent terms gives a good description of silk production, which in part explains why silk

threads react the way they do. The Centre International d'Étude des Textiles Anciens (CIETA), based in the traditional French silk-producing centre of Lyon (today also one of the last centers of production of metal thread) is particularly concerned with the study of historical silk textiles. The following terms describe important parts/constructions: bave, brin, cabled yarn, double, end, fibre, fibroin, filament, filé, frisé, grège, grenadine, gum sericin, gummed silk, lamé, lamella, organzine, plied yarn, ply (n. and v.), poil, reel (v.), schappe, silk, single, soft silk, souple, spin, thread, throwing, thrown silk, tram, tussah, twist, waste silk and yarn. See further in Sykas (2000) for pertinent and elucidating instruction.

## Identification

Microscopy and low-energy X-radiography are most useful in identifying silk fibres as well as defining the structure both of the fabric and of the constituent yarns. Scanning electron microscopy (SEM) provides exceedingly detailed images of both fibres and weaves and can also be expected to indicate whether the silk threads used have been weighted (Indictor and Koestler 1986; Brooks 1996). However, SEM should not be used indiscriminately to browse around on deteriorated textiles, as the electron beam which captures these amazing images can damage weakened fibres (Shashoua 1996). In the present study, SEM images have been taken of a series of samples, both as cross-sections and side views. They confirmed the initial evaluation of the cores done with microscope examination at low magnification.

Other factors affecting the condition of the core thread are the number of filaments present, and the silk's weighting, dyeing, and mordanting. Little information has been found about the weighting of silk thread traditionally used as cores for gilt and silver thread. Testing for weighting is not easily carried out on the short ends available from museum objects. It might be expected that an unweighted - or pari-weighted yarn - would be chosen as core material, as it might be considered the best quality for the relatively expensive finished product, but as of now, no information has been collected as to what kind of silk has been used as core material. Burn-tests for weighting are often inconclusive given the small samples that can be obtained, though with practice and combined with other tests it may be possible to discern weighting as against non-weighting. Other factors such as finishing treatments and the fibres' intimate proximity to corroding metal may also influence the outcome of a burn test. It is not necessarily detrimental to the silk as such to be weighted. Weighted silk swells less than

unweighted silk in the reagent copper oxide ammonia (kuoxam) and perhaps also in water alone, according to Himmelreich (1975).

One of the chemicals metal conservators have used for removing silver corrosion is EDTA, which unfortunately is also known to have removed colour from dyed silk (though the silver did indeed glitter after the treatment). The EDTA apparently dissolved either the mordants, the dyestuff, or disrupted the bond between the dye and fibre, causing the colour to disappear. Thus, if the yellow dye of a core thread has been mordanted with a metal salt, it may dissolve or change colour in EDTA. Rinsing it out does not lessen the damage, which has already occurred on contact. This might even be acceptable in some cases for cleaning gilt thread, which is traditionally wound on a yellow core, but it is imperative that the silk itself not be structurally damaged by the process.

Among the many yellow dyes traditionally used on silk are: dyer's broom, curcuma, quercitron, saffron, safflower, weld (*R. luteola*), fustic, and Persian berries, none of which give a very lightfast colour. They are often mordanted with alum, tin, or chrome. White core threads (inside silver wrappings) are undyed, as the silk filaments are naturally white, though covered with the very yellow sericin (silk gum) which is removed before the thread is reeled. The white silk may have been bleached, occasionally with sulphur fumes, residues of which might also be detrimental to the silk and certainly for the silver wrapping (Ballard et.al. 1989). There is no sulphur naturally present in silk filaments to cause silver wrappings to tarnish.

## Silk and water

Wet cleaning of textiles is an irreversible process whose individual procedures can scarcely be controlled once instigated – not a favorite situation for any conservator. Ground-breaking discussions of the problems involved for wet and drying fibres have been published by Francis (1992), Ballard (1996), Howell (1996), and Tímar-Balázs (1999), indicating that the physical stresses on silk during wet cleaning and drying are considerable. Water alone can hydrolyze very degraded fibres (Tímar-Balázs 1989). Add to this the following exacerbating conditions:

- the silk fibres may already be damaged mechanically or chemically;
- fibres held in place and compressed inside wrappings of metal, itself impervious to water;
- fibres under tension, held fast at each end of a stitch through layers of fabric;

- silk's natural relaxation and loss of strength while wet;
- potential mechanical damage during cleaning.

Even changes in relative humidity begin to look dangerous for metal embroidery! It is also known now that the drying – or equilibrium – process may take weeks or months for textiles. Choosing a suitable pH for any wet treatment is difficult for silk objects as the pH may vary greatly within the same piece, which may contain areas badly deteriorated by light as well as undamaged areas. Another variable to be considered is the potential effect of the electrical current of the proposed treatment on wet silk fibres. At present it is considered minimal, given the proximity of metal, but neither has this ever been investigated. Scientific investigations of silk have never been undertaken to the degree that metals – vitally important to industry and warfare – have enjoyed.

Any wet treatment of silk – or other textiles – is best initiated with a gradual humidification in a closed container, allowing fibres to absorb water gradually. Their increased flexibility as they absorb water reduces the dangers of sudden and partial swelling and breaking which occur when dry fabrics are immersed. Wet silk threads can be expected to swell in a transverse direction, which necessarily strains them longitudinally. As the metal threads and the stitches holding the *cantilles* (metal wire wrapped as a thin spiral) are already under tension, their shrinking along the thread's length can only mean trouble, particularly at the vulnerable point where the thread enters and emerges from the fabric. When this breaks, the cantille falls off. Re-stitching is rarely possible without deconstructing the entire embroidery.

Even aside from the problems silk itself faces with water and the proposed cleaning processes, the construction of the museum object and the constituent parts of the embroidery may also be susceptible to irreversible damage from a wetting and drying process. Raised embroidery can consist of layers of fabric, cardboard, leather, or wooden shapes, each glued to the next layer. In addition, the reverse of an embroidery, which is itself usually lined so that stitching is not anchored in the ground fabric alone, was often brushed with glue to secure thread ends and give the finished product more body. These materials and the often copious amounts of glue complicate at the least any wet cleaning process. Metal embroidery on velvet, a favourite combination for luxury goods, presents even more complicated problems, as it can be difficult to retain the gloss and evenness of pile-woven fabrics like velvet after wet cleaning.

## Metal threads in textiles

Metal threads in textiles are found primarily in weaving (in which the resulting fabric is often a brocade) and embroidery. The metal components can be integral or applied, such as sequins, which are attached by stitching. A classic description of traditional gold embroidery techniques, including descriptions of the many types of metal threads, is found in Saint-Aubin's *Art of the Embroiderer* (1770). Descriptions of the technology of making the metal threads themselves, that is, drawing wire, rolling and cutting and wrapping around silk cores, are found in various sources such as guild laws for wiredrawers and silk throwers. Márta Járó of the Hungarian National Museum, Budapest, has participated in an ongoing research program on the manufacturing techniques of Hungarian metal threads for many years, though also here the focus has tended to be on analyses of the metals and their corrosion with little description of the cores (Járó 1991, Fig.1). A recent comprehensive study of metal threads from ecclesiastical textiles in Stockholm mentions, again, only the core material and colour (Bergstrand et al. 1999), though the authors were not unwilling to go back and examine the core threads more closely when appraised of the potential value of this information. New work is ongoing (see note 3).

The silk thread on which cantilles is threaded as well as the silk thread used for couching laidwork is waxed with beeswax as the work progresses. Nuggets of beeswax are seen right at hand in for example the eighteenth-century *Diderot Encyclopedia* illustrations of gold embroidery. The wax was reported to have been kept in the embroideress's bosom, warming the wax to the best consistency. Today beeswax is still used in metal thread embroidery, strengthening and smoothing the working thread during the repetitive motions of pulling it through the tough fabric layers. Though its presence has not been looked for in this study, it might be considered beneficial, to some degree protecting the silk threads from immediate wetting, though, for the same reason, slowing down the drying process once the threads have become wet.

## Proposed cleaning method

Cleaning of metal threads has often been a point of controversy between metal conservators and textile conservators, as the two materials have widely different tolerances. At best, treatment has been avoided, but corroded gilt and silver textiles are a

sorry excuse for the brilliant and luxurious appearance they had when new. Historians and museum guests alike would like to see such textiles in their original state, even knowing that re-corrosion is inevitable. The silk sewing threads used for couching, stitching, and as core material are always affected by the usual cleaning methods for corroded silver, not least by the mechanical damage resulting from 'scrubbing' and residue of granular polishing agents which cut brittle silk fibres. Several new methods of reducing the speed of re-corrosion have now been developed<sup>1</sup> and should be used, as preventive conservation must have highest priority when the cleaning process is as difficult or dangerous for the object as it is here.











| Sign of the thread | Description of the thread                                                                   | Picture of the thread                                                                 |
|--------------------|---------------------------------------------------------------------------------------------|---------------------------------------------------------------------------------------|
| A                  | metal strip                                                                                 |    |
| B                  | metal strip (A) wound around a fibrous core                                                 |    |
| B1                 | B type metal thread wound around a fibrous core                                             |  |
| B2                 | B type metal thread wound around another, also B type thread                                |  |
| B3                 | A type metal thread (strip) wound around a B type thread                                    |  |
| B4                 | two B type threads twisted                                                                  |  |
| BX                 | A type thread (strip) wound around a B type thread held together with metal strips (A type) |  |
| C                  | wire                                                                                        |  |
| C1                 | two wires (C type) twisted                                                                  |  |
| D                  | wire (C type) wound around a fibrous core                                                   |  |

FIGURE 1 Types of metal threads, from Járó 1991.



## Test material, tensile strength tests

During this study various silk core threads from embroidery and brocades – primarily from the seventeenth and eighteenth centuries – have been examined. No two are alike. The samples are taken from objects in the Royal Danish Collections at Rosenborg Castle, which are unique in that all the costumes are extremely well documented as to date and use, none have been washed, and few of the objects have been conserved. The variety and qualities of silk core thread are numerous, and there is also great variation in their state of preservation. For no apparent reason, some silk cores are literally powdering to pieces, while others, known to have been exposed to much use and/or light, are in seemingly good condition. For the record, it is not apparent that any of these costumes has ever been washed, and only one has undergone an otherwise undocumented cleaning of its silver embroidery, 50 years ago. The weighting of these silks has not been tested, nor has their dyeing and/or mordanting, though these treatments seem to have been more detrimental for the black or dark silks found in the costumes themselves. For gilt and silver threads only yellow and white are found as core material; gilt threads always have yellow cores and silver threads always white. There are some unplied yarns as well

as 2-3-4-ply yarns of various constructions. Generally, the more plies in a thread, the rounder and smoother it is; theoretically an advantage for a core structure (Sykas 2000:124). The number of core filaments varies from 6 to over 80. It seems that the tightly plied yarns are in poorer condition than the unplied yarns. Other aspects are how tightly and closely the metal has been wound onto the core and how sharp the edges of the metal are – and of course, how the metal thread has been worked in the textile and how the textile itself has been treated.

As far as the new cleaning method itself is concerned, at first it was carried out locally using anodes and cathodes, with cotton wool swabs, directly on the object. The most appealing aspect, which formed the basis of the investigation, was that little wetting occurred. The method was developed by Karen Stemmann Petersen and Bodil Taarnskov (1999) at The National Museum of Denmark. Various different electrolytes were chosen according to their efficiency and assumed compatibility with silk's pH. The method has been used with fair success on gilt braids removed from various museum objects which can be submerged; however, because it became necessary to use a greater amount of water during treatment than expected, this method cannot now be recommended for textiles which do not otherwise tolerate wet cleaning.

A number of tensile strength tests were performed on new silk embroidery thread.<sup>2</sup> (Fig. 2) Threads were



FIGURE 2  
Test results of  
tensile strength,  
treated and  
untreated new silk.

tested dry; wet, after 20 minutes, after 1 hour and 24 hours soaking; dry, after having been soaked for the same intervals above; and dry, after the same intervals of soaking and additionally artificially aged by light and heat. The most damage was shown after the artificial ageing, which drastically reduced the silk's extension before breaking from about 22.6% to between 12.9-16.3%. Lustre and colour were also affected by wetting and subsequent drying, a result which must be investigated as it indicates that at least the surface of the threads has been altered. A way of measuring the thread's swelling when wet within the metal wrapping would be useful, to indicate what kind of mechanical damage might occur during the wetting and drying. The EDTA-solution appeared to be the most detrimental of the liquids used. The sample material for these tests was an undyed, unspun new floss silk, approximately 30 filaments, embroidery yarn, unweighted. The tests indicated that water itself accounted for most of the loss of the silk's tensile strength. Measuring silk's flexibility under the same conditions may also have provided important information.

## Determination of degradation: how to evaluate old silk

Of primary importance for implementing the proposed treatment is a way to measure the actual degradation of the silk threads and cores. Only exceedingly small samples are ever available for testing, as gold embroidery rarely has extraneous thread ends on the reverse which can be taken for tests. Preferably some form of systematic analysis could indicate what the primary causes of the degradation are. Photochemical damage may differ from mechanical damage or damage from alkalies, all of which may in addition have differing impact on weighted and/or dyed silks. The relative importance of whether the silk is weighted, how much and with what still needs to be described (Bogle 1979). Changes in the weighting, dyes and mordant may also occur during the degradation of the fibres over time or when water is present. Chemical methods of evaluating silk degradation, such as measuring the viscosity of the silk fibres may be a good indication of changes in the ratio of amorphous-crystalline regions and thus a way of measuring degradation.<sup>3</sup> Other methods include thermal analytical and infrared microanalytical techniques. Until these laboratory methods have been developed and simplified, however, visual and tactile evaluations need to be cultivated and respected as viable alternatives.

## Terminology

No official terminology for threads and their components seems to be widely used by textile conservators. As thread is today industrially produced, some of the aspects – and terminology – of handmade materials are no longer pertinent. For example, *doubling* was originally twisting a strand in one direction, doubling it back on itself and allowing it to twist itself together: simple when done by hand, but not on machines involving twisting two separate elements and reversing them onto each other. In addition, describing a thread of known materials and production method is easier than identifying a core thread of which very little is visible or available for study. As always, we must be careful to distinguish between technique and product, and we must learn to be very specific. Other terminologies may be more useful in other languages, but differing use of terms can always be ironed out if illustrations are provided. For an excellent discussion, see Sykas (2000).

Emery's system (1966) divides thread constructions into two major groups: those made of continuous filaments (like silk) and those made of fibres of limited length. Silk filaments are not spun, as such; spinning is the term for drawing out short fibres while combining them in a twisting process. Filaments can simply be grouped without any twist required, in three ways:

1. **single:** the simplest usable unit. Silk worms secrete filaments in pairs, called baves, which are too fine and fragile to be used alone, so the term single usually denotes a group of 3-10 pairs of silk filaments, whether twisted together or simply combined.
2. **combined:** the process of combining two or more continuous filaments for use as a unit without twisting them. Sometimes described as doubling.
3. **twisted together:** the process of twisting together two or more filaments, or unit-groups of filaments, to form a twisted yarn is described as throwing. The equivalent for spun yarns is *plying*.

**Spun** fibres, for example short pieces of silk filament, are made into a continuous strand by twisting them together and drawing them out. Shorter lengths of wild or waste silk are spun.

1. **single** yarn is the simplest continuous aggregate of spun fibres that is suitable for fabric construction
2. **combined** yarn of two or more spun yarns used as a unit but not twisted together (paired, triple, multiple)
3. **plied** yarn is formed by twisting together two or more single yarns. The process is called plying,

|                                                                                               |               |               |                 |
|-----------------------------------------------------------------------------------------------|---------------|---------------|-----------------|
| <b>dry, twisted sample</b><br>74,614–22,8%                                                    |               |               |                 |
| <b>dry, twisted sample, acclimated (24 hours constant climate) untreated</b><br>74,760–22,56% |               |               |                 |
| <b>dry, untreated sample, artificially aged</b><br>66,345–17,13%                              |               |               |                 |
| <b>wet samples</b>                                                                            | <b>20 min</b> | <b>1 hour</b> | <b>24 hours</b> |
| <b>water</b>                                                                                  | 57,202–30,98% | 58,107–32,00% | 57,679–31,39%   |
| <b>solution #1</b>                                                                            | 57,994–30,97% | 59,715–32,49% | 58,101–31,72%   |
| <b>solution #4</b>                                                                            | 56,774–31,22% | 56,996–31,9%  | 55,447–31,18%   |
| <b>solution #6</b>                                                                            | 58,846–32,53% | 57,013–31,53% | 56,506–31,75%   |
| <b>dry samples after soaking (as above)</b>                                                   |               |               |                 |
| <b>water</b>                                                                                  | 73,158–24,05% | 74,201–25,04% | 72,543–24,46%   |
| <b>solution #1</b>                                                                            | 72,578–24,51% | 74,368–25,00% | 68,931–21,41%   |
| <b>solution #4</b>                                                                            | 73,269–23,95% | 72,818–24,20% | 72,487–23,49%   |
| <b>solution #6</b>                                                                            | 74,809–24,65% | 72,935–24,12% | 70,543–23,36%   |
| <b>dry samples after artificial aging by light/heat</b>                                       |               |               |                 |
| <b>water</b>                                                                                  | 64,592–17,31% | 65,599–17,97% | 62,132–16,8%    |
| <b>solution #1</b>                                                                            | 58,080–14,20% | 57,748–13,65% | 55,657–12,87%   |
| <b>solution #4</b>                                                                            | 61,564–16,04% | 61,022–16,02% | 58,957–14,73%   |
| <b>solution #6</b>                                                                            | 63,897–16,98% | 63,164–16,86% | 62,005–16,29%   |
| <b>dry, untwisted sample, acclimated</b><br>81,072–30,19%                                     |               |               |                 |
| <b>dry, untwisted sample, artificially aged</b><br>71,638–25,87%                              |               |               |                 |

FIGURE 2 Test results of tensile strength, treated and untreated new silk.

and the direction of plying is usually opposite to the direction of the spin of the single yarns employed.

4. **re-plied** yarn is a three-process construction formed by re-plying or twisting together two or more plied yarns, the direction of the twist usually opposite to that of the plying.

Wendrich uses the terms yarn, string and cable to refer to the three successive processes of spinning, plying and cabling (Fig. 3). A drawback in using this terminology, developed for describing basketry which is often of large dimensions, is that ‘cable’ seems – in terms of size – a misnomer for a composite thread used as core, even though the construction may be the same (Wendrich 1994).

When examining core threads on museum textiles, it is generally impossible to ascertain whether we are dealing with filaments or spun fibres because we can only see short lengths at a time. However, we can describe the thread’s components and direction of twist, tightness (or angle) of twist, and if microscopes are available, the approximate diameter and number of fibres in each strand. It should be noted that winding a metal lamella onto the core imparts some twist in itself which may be auxiliary to the core’s original twist. How tightly the metal is wrapped around the core and how close its spiral will also affect the well-being of the core fibres. In general it seems that tightly plied core threads are often in better condition than those with fewer and looser plies and might thus be less susceptible to damage from wet treatment.

Direction of twist is the classic S, Z description. Threads without obvious twist can be called I (Fig. 4). In the short samples available to us for examination, twists per centimetre can rarely be counted, so the tightness of the twist must be judged by the angle (helix angle) alone. The angle of twist refers to the angle that the slant of the twist makes with the longitudinal axis of the yarn. Generally angles up to 10° are called loose; 10-25° medium; 25-45° tight

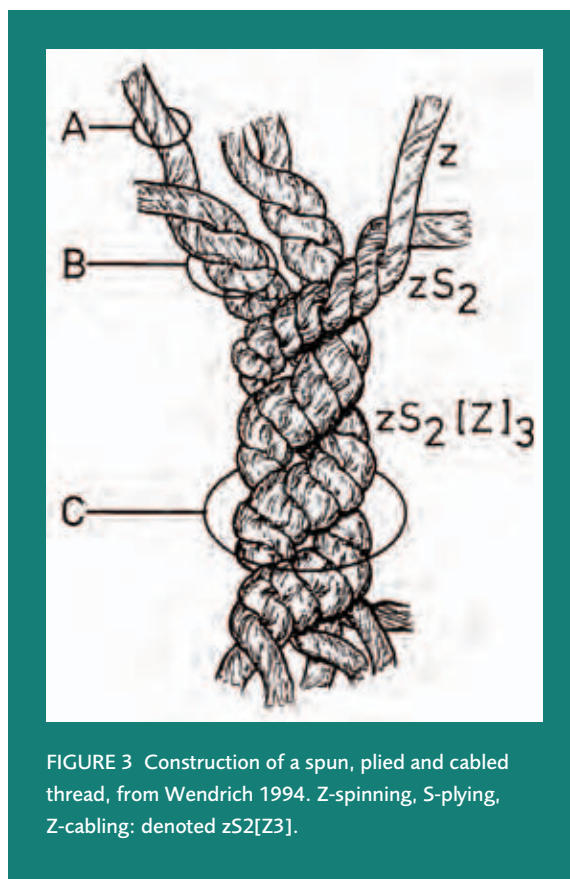

FIGURE 3 Construction of a spun, plied and cabled thread, from Wendrich 1994. Z-spinning, S-plying, Z-cabling: denoted zS2[Z]3.

(Fig. 5). For conservation purposes it is better to measure the angle of twist than to count the number of revolutions per given length (which is rarely possible anyway). Threads of different thicknesses can have the same angle of twist but with fewer revolutions per measure of length; they are equally tightly twisted, but the different number of twists per meter would differentiate the two yarns greatly in the textile industry. (Fig. 6 from Taylor 1997).

Documentation of a thread's construction should, according to Emery, always end with the final – visible – twist emphasized with a capital letter (e.g. z-S, s-s-Z, s-z-s-Z). Enumeration of a thread's integral parts according to their direction of twist

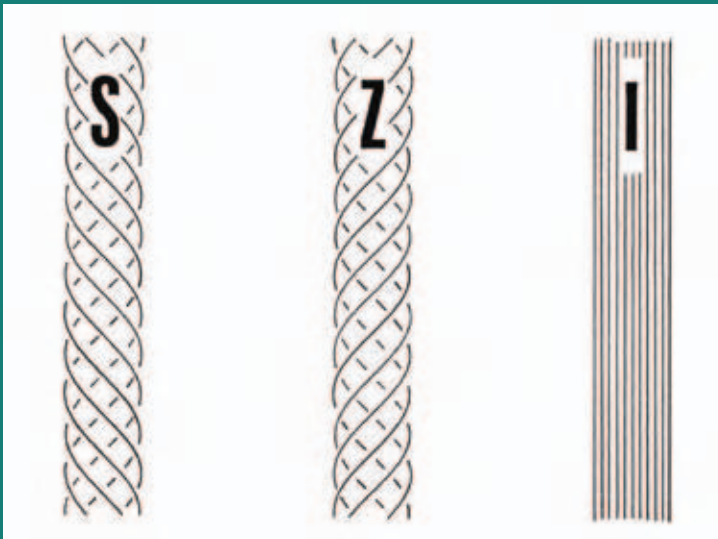

FIGURE 5 Designation of angle of twist, Emery 1966.

FIGURE 6 Same angle of twist but different number of revolutions per length, from Taylor 1997.

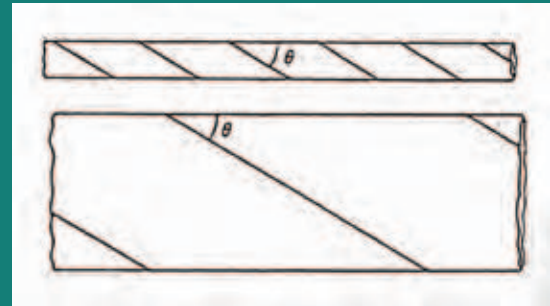
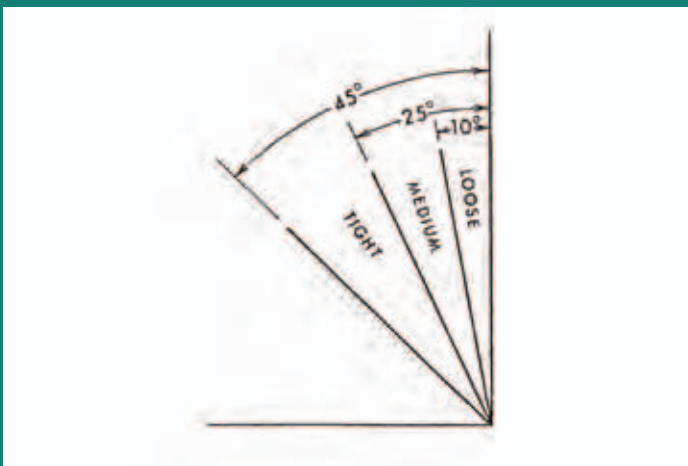

FIGURE 7 The same angle of spinning and different number of twistings in a given length.

is probably the clearest form for identification, although there are undoubtedly some sequences that defy this system. It may be clearer to indicate the number of components by numerals, for example  $zS_2$  as developed by Wendrich. This would describe a string composed of two z-spun yarns, plied in S-direction. A notation of  $2zS$  has been seen for the same thread; it will undoubtedly be a matter of preference and experience that determines the kind of notation one chooses. Once notation becomes common, it will become clearer which type is more readily understood. In any case there is no need to invent more notation systems! For clarity, any notation should be accompanied by a sketch.

## Conclusion

As indicated, certain information is necessary to evaluate whether metal threads can withstand a wet cleaning. In lieu of potential chemical analyses to measure a specific core thread's state of degradation, it will be necessary to continue to evaluate each thread subjectively. To do so, one must become experienced, and this happens only after gathering specific information through systematically examining and recording a large number of samples and following up after any wet treatment. The following points indicate how to accumulate the knowledge and quality of observation that are necessary, and which factors must have higher priority in our documentation:

- Learn to identify, describe, and draw the component parts and materials of a metal thread embroidery.
- Try to assess the state of degradation of the silk threads found as core, as stitching and couching, and as warp and weft in brocades. A knowledge of the object's previous treatments and exposure to light is valuable, but there are surely great

differences of condition even within the same object.

- With a microscope it will be possible to see if there are many broken silk filaments protruding from between the metal spirals on a wrapped thread. Broken metal threads sticking out of brocades can be seen without a microscope. Both instances indicate previous and probable ongoing mechanical damage to the silk.
- The microscope will also help to reveal whether the silk core is tightly packed inside the metal, which means the silk does not have room to expand when exposed to water.
- Threads that are tightly twisted and/or plied have an innate torsion which will be a damaging factor when wet, 'relaxed' fibres begin to dry.
- The presence of wax on silk stitching threads will delay wetting but will concordantly also extend the dangerous (that is, uncontrollable) drying phase.
- Weighting, dyeing and mordanting agents on silk might be damaged by the chemicals used to dissolve silver corrosion.
- Preventive conservation should be stressed – handle as little as possible, wear clean gloves when handling, protect from light and air, isolate from materials that promote tarnishing of metal threads (such as rubber), investigate the use of scavengers of agents of deterioration, charcoal blankets, etc., to slow down corrosion.
- Increase efforts to explain to the public why metal embroidery and brocades on display now look dull (everyone understands air pollution) and haven't been 'shined up'; include photographs of hidden areas of embroidery which still are shiny; set light to catch just a bit of sparkle somewhere on the object.

## Postscript: a traditional method

Saint-Aubin describes the following cleaning method for metal embroidery:

Strong perfumes easily darken Embroidery work, especially when it is executed in silver thread. This Embroidery is cleaned with dry bread crumbs heated in a small, clean saucepan. The hot bread crumbs are sprinkled on the embroidery. They are then rubbed with the palm of the hand. They are spread out in such a way that they cover the entire work. This is then all covered with several layers of clean linen. When the crumbs are cool, the frame holding the Embroidery is turned over, tapped on the reverse side with a switch [light-weight brush

or stick], and then brushed clean. It is at this point that glue or starch is spread over the underside of the Embroidery. Cleaning may also be accomplished by the use of burned and finely sifted talc or of dry pulverized cuttlefish bone. Certain people know the art of lightening tarnished gold and bringing back its colour and shine without harm to the base material of the Embroidery. This, however, is a secret process passed on from father to son, a talent that one family in Paris depends on to earn its living ... One can also bring colour back to faded gold, in some instances, by exposing it to the smoke from feathers or burning hair ... There are other processes derived from the above depending on the materials used and the talent of the person using them. I have attempted to point out in this Work the most familiar of these.'

Given modern micro-vacuuming techniques to remove insect-attracting residue, it may again be worthwhile to experiment with breadcrumbs!

## Acknowledgements

I am grateful to the Danish Ministry of Culture for having provided funding for this project, and to the former director of The Royal Collections, Mogens Bencard, for supporting the application. Thanks also to colleagues Karen Stemann Petersen and Bodil Taarnskov at the National Museum for their interest and participation.

## References

- Ballard, M.; Koestler, R.J.; Blair, C.; Santamaria, Claudia; Indictor, Norman, 1989. Historic Silk Flags from Harrisburg. In: *Historic Textile and Paper Materials II, Conservation and Characterization, Developed from a symposium sponsored by the Cellulose, Paper and Textile Division at the 196<sup>th</sup> National Meeting of the American Chemical Society, Los Angeles, California, September 25-30, 1988* / Zeronian, S. Haig (ed.); Needles, Howard L. (ed.); Washington, D.C.: American Chemical Society: 134-142.
- Ballard, M. 1996. Hanging Out: Strength, Elongation, and Relative Humidity: Some Physical Properties of Textile Fibres. In: *Triennial meeting (11th), Edinburgh, 1-6 September 1996: preprints*, ICOM. Committee for Conservation. Paris, France. London: James & James: 665-9.
- Bergstrand, M.; Hedhammar, E., Nord, A.G.; Tronner, K. 1999. All that glitters is not gold: an examination of metal decorations on ecclesiastical textiles. In: *Triennial meeting (12th), Lyon, 29 August - 3 September 1999: preprints. Vol. 2*, ICOM. Committee for Conservation. London: James & James: 621-4.
- Bogle, M. 1979. The deterioration of silks through artificial weighting. *Textile Conservation Notes* No.11, North Andover, Massachusetts.
- Brooks, M.M.; O'Connor, S.; McDonnell, J.G., 1996. The application of low-energy X-radiography in the examination and investigation of degraded historic silk textiles: preliminary report. In: *Triennial meeting (11th), Edinburgh,*

- 1-6 September 1996: *preprints*, ICOM. Committee for Conservation. Paris, France. London: James & James: 670-9.
- Centre International d'Étude des Textiles Anciens (CIETA) 1964. *Vocabulary of Technical Terms*. Lyon: CIETA.
- Emery, I. 1966. *The Primary Structures of Fabrics*. Washington, D.C.: The Textile Museum.
- Francis, K. 1992. Observations on the drying behaviour of textiles. *The Textile Specialty Group Postprints*, AIC, 1-9.
- Himmelreich, W.; Otto, F.; Pospischil, E. 1975. *Prüfmethoden für die Labors der Textilindustrie*, Leipzig.
- Howell, D. 1996. Some Mechanical Effects of Inappropriate Humidity on Textiles. In: *Triennial meeting (11th), Edinburgh, 1-6 September 1996: preprints*, ICOM. Committee for Conservation. Paris, France. London: James & James: 692-8.
- Indictor, N.; Koestler, R.J. 1986. The identification and characterization of metal wrappings in historic textiles using microscopy and energy dispersive X-ray spectrometry: problems associated with identification and characterization. In: *Scanning Electron Microscopy II*. Chicago, USA.
- Scanning electron microscopy in the diagnosis of "diseased" stone / Lewin, Seymour Z.; Charola, A. Elena, In: *Scanning electron microscopy*, Vol. 1: SEM INC., 1978,
- Járó, M. 1991. Among many others, *Newsletter of the Working Group of Textiles, ICOM Committee for Conservation*, 2.
- Mauersberger, H. (ed.) 1947. *Matthews' Textile Fibers: their physical, microscopical, and chemical properties*, New York: J. Wiley & Sons.
- Metcalfe, S. July 1997. Weighing up silver objects: evaluating past and future conservation methods / Metcalfe, Simon, *V & A conservation journal*, N. 22, 1997, p. 4-5.
- Ryder, M.L.; Gabra-Sanders, T. 1985. The Application of Microscopy to Textile History. *Textile History*. Vol. 16 No. 2.
- Saint-Aubin, C. 1770. *Art of the Embroiderer*. Complete French text, translation and annotation by Nikki Scheuer, Los Angeles County Museum of Art, 1983.
- Shashoua, Y. 1996. Investigation into the Effects of Cleaning Old, Dyed, Naturally Soiled Textiles by Aqueous Immersion. In: *Triennial meeting (11th), Edinburgh, 1-6 September 1996: preprint*, ICOM. Committee for Conservation. Paris, France. London: James & James: 714-20.
- Stemann Petersen, K.; Taarnskov, B. 1999, poster presented at the ICOM Conservation Triennial in Lyon, 1999.
- Stemann Petersen, K.; Taarnskov, B. 2001. Electrolysis of silver and gilt silver threads on silk textiles. *Exposure 2001, Preprints of the Conference on Metal Corrosion 7-10 November 2001, Hildesheim, Germany*.
- Sykas, P. A. 2000. Re-threading. Notes towards a history of sewing thread in Britain. In: M. M. Brooks (ed.) *Textiles Revealed: Object Lessons in Historic Textiles and Costume Research*. London: Archetype.
- Taylor, A. 1997. *Technology of Textile Properties*. London: Forbes Publications.
- Timár-Balázs, Á. 1989. Deterioration process of fibres in different chemical actions. In M. Jaro (ed.) *Conservation of metals. Problems in the treatment of metal-organic and metal-inorganic composite objects. International restorer seminar. Veszprém, Hungary, 1-10 July 1989*. Veszprém: Istvan Eri. p. 77-82.
- Timár-Balázs, Á. 1999. Drying behaviour of fibres. In: *Triennial meeting (12th), Lyon, 29 August - 3 September 1999: preprints*. Vol. 2, ICOM. Committee for conservation. London: James & James: 661-6.
- Wendrich, W. 1994. *Who is Afraid of Basketry? A guide to recording basketry and cordage for archaeologists and ethnographers*. Leiden: Centre for Non-Western Studies.

## Endnotes

- 1 Pollutant monitoring in storage and display. Pollutant adsorbents such as zinc oxide (ICI Katalco) and charcoal cloth (Charcoal Cloth International Ltd). See Metcalfe 1997. Protecting metal embroidery with a metal lacquer cannot be recommended.
- 2 Tests done at the Danish Technological Institute, Herning, Denmark. The tensile strength test was according to the ISO 2062:1993. The artificial ageing was done in a Xenotest 450, ISO 105-B02:1988.
- 3 Important work in this area is progressing at the Canadian Conservation Institute, Ottawa, Canada and has also been examined at the Victoria and Albert Museum, London. New work is being done (2002) by Tamsin Collins, UK on cores of metal threads. Paul Garside and Paul Wyeth, UK, are also investigating silk deterioration (2002).

Fashions change from season to season under the dictates of the leading design houses, and the process can be easily followed worldwide. However, in the period considered in this paper, changes in the cut of clothes and shoes happened much more slowly than today. People's clothing was influenced not only by current trends but also by certain important events in history. This was also true of Hungary, where both Eastern and Western influences were felt due to its special geographical position.

[ MÁRTA KISSNÉ BENDEFY ]

# Eastern and Western influences on Hungarian footwear of the thirteenth-seventeenth centuries

TO THE MEMORY OF ÁGNES TIMÁR-BALÁZSY WHO KINDLY SUPPORTED MY RESEARCH FOR TWENTY YEARS

**T**his paper summarizes some of the conclusions from our study of the types and technology of Hungarian footwear between the thirteenth and seventeenth centuries; the study has been undertaken for nearly ten years by the author and Judit Bakay-Perjés.<sup>1</sup> Our research has been based on finds from archaeological excavations of Hungarian sites and on objects that were taken into historic collections; most of the finds are complete shoes and boots, and are primarily men's footwear.

Unfortunately, due to the temperate, continental climate and soil conditions in Hungary, most organic materials decompose in the ground. Before the 1950s leather finds, which were rare and mostly fragmentary, could not be properly treated to 'restore' them, so only a few survived. Later excavations, mostly from castles (e.g. Tata, Buda, and Szolnok) and cemeteries, produced a larger number of leather goods, primarily footwear,<sup>2</sup> which were successfully 'restored'.<sup>3</sup> In our research we have examined some of these finds and

some of the historic footwear in the Textile Collection of the Hungarian National Museum.

In order to implement a suitable examination methodology, a special documentation approach had to be developed; it provides more data on the fragmentary footwear from excavations than before, focusing on technological aspects. The most frequently applied stitches and seams on leather were documented to create an information resource pack. In developing the documentation methods (including the drawing of the different types of seams), European standards were followed as much as possible. The long-term objective is to give the documentation a coherent, easily comprehensible format for everyone.<sup>4</sup> A certain part of the project was sponsored by the Hungarian National Scientific Research Fund.<sup>5</sup>

The paper starts by showing changes in shoe types, using archaeological finds, contemporary illustrations and analogous material; this section is followed by a comparison of different types based on their technology.

## Changes in shape

As the different types and shapes of Hungarian footwear have been thoroughly described in several publications on the history of arts and fashion, what follows is a brief summary to make the technological details more comprehensible.<sup>6</sup> The clothing and footwear of Hungarians, who arrived in Central Europe from the east in the ninth century, were typically Oriental in every aspect. However, in the following centuries most Hungarian rulers fostered the spread of Western culture and customs within Hungary. This influenced fashion as well, first among the upper layers of society; Western fashions then became more and more popular.

Unfortunately, only a few identifiable leather fragments have been found from before the thirteenth century. But, from the thirteenth, fourteenth and fifteenth centuries, complete shoes as well as

fragments survive, and reconstructable footwear fragments have been discovered by archaeologists.<sup>7</sup> (Figs. 1 and 2) The excavations led by Dr. Dóra Nyékhelyi<sup>8</sup> on the Budavár site in the Teleki Palace between 1998 and 2000 led to a real breakthrough in research on mediaeval footwear. The finds from the site are in especially good condition so they can be used to corroborate and correct some previous assumptions (Figs. 3 and 4).

On the evidence of contemporaneous depictions and archaeological finds, low-cut shoes, ankle-shoes and boots were equally popular in Hungary in the thirteenth to fifteenth centuries. They followed the shape of the feet, but the toes were pointed and they were fastened with lacing, latches, buttons or buckles. In the fourteenth and fifteenth centuries, stockings with leather soles were sometimes worn. The boots as well as the shoes were tightly shaped

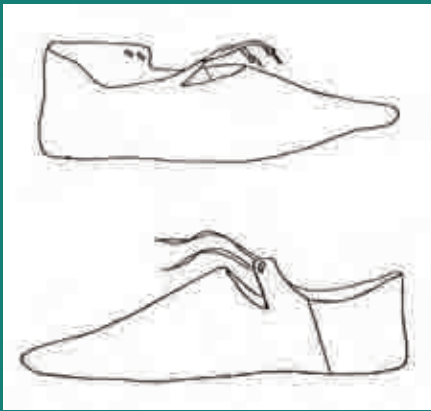

CLOCKWISE FROM UPPER LEFT:

FIGURE 1 Two typical shoe-types which turned up in an easily reconstructable state. The ones on the top are fastened with a pair of side latches, the bottom ones with one pair of latches.

FIGURE 2 Low-cut shoes in an illustration from Hungary dated to 1360-70.

FIGURE 3 Footwear extending above the ankles from the fourteenth-fifteenth century. Budapest History Museum, BTM KO.2001.3.1.

FIGURE 4 An illustration with ankle-shoes, fifteenth century.



to the feet. Usually they were short, ankle- or calf-length (Fig. 5). By the end of the fifteenth century, long, pointed toes were replaced with the more fashionable rounded ones in most parts of Europe. Long tongues were applied, with lachets from the sides tied at the front over the tongues. The vamp was often decorated with slits that had leather strips threaded in.<sup>9</sup> (Fig. 6).

From the late fifteenth century, as a result of persistent Turkish attacks, a new military garment developed which was more suitable to fast movement than the earlier cavalry uniforms. This shared many features with the Turkish light cavalry. Hungary was divided into three parts in the early sixteenth century: the central and southern parts were ruled by the Turks for more than 150 years; the northern and western parts belonged to the Habsburg dynasty; the eastern part, Transylvania, was an independent prin-

cipality. Naturally the extent of Western and Eastern influences was different in these three parts. The above mentioned Western-style footwear was found among the finds from the northern and western parts (e.g. Tata and Sárospatak), while the Oriental-type shoes originating in Turkey were found mostly in excavations in the central part of Hungary.

Oriental footwear is rather different from the Western types described above. There were three main types: boots, slippers and leather socks. Men, mostly the soldiers, wore boots, often with slightly turned-up toes. The front part of the boot was almost knee-high while the back was often lower-cut to let the rider move more freely (Fig. 7). These boots were usually heel-less; the soles were protected from wear with iron heels or heel-protectors. Slippers, like the boots, were heel-less, or had low iron heels. They were worn both indoors and outdoors (Figs. 8 and 9). Leather

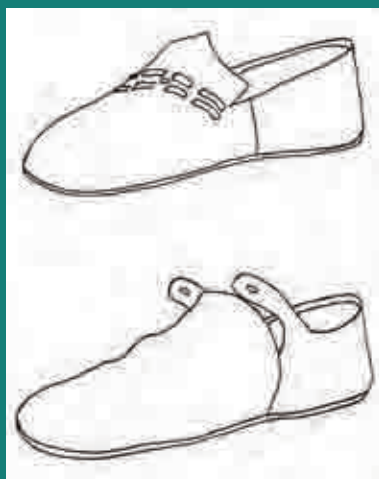

CLOCKWISE FROM UPPER LEFT:

FIGURE 5 An illustration of short, soft boots, c.1480, Christian Museum, Esztergom.

FIGURE 6 Typical Western footwear from the sixteenth century; reconstruction sketches from excavations at the Tata castle site.

FIGURE 7 Boots from the seventeenth century, Hungarian National Museum, (HNM ) 1964.617.1.2.

FIGURE 8 Turkish slippers from the sixteenth century, HNM.

FIGURE 9 Slippers have been used even with long-legged boots in some Oriental countries. A detail of a miniature from India from the early seventeenth century

stockings were short, usually only ankle-length and they had side slits with lacing. They were made of soft, usually yellow or red leather. Slippers were worn over them if they were worn outdoors. The colours and decorations of the stockings and slippers were carefully matched (Figs, 10 and 11).

The combination of slippers and leather stockings resulted in a new type of footwear which extended above the ankle, had side latches, and the seam on the vamp imitated the shape of the slippers worn over the leather stockings. This type was made with heels of iron in an Oriental fashion, or of leather-covered wood, indicating a return to a Western style (Figs. 12-14). In the late seventeenth century, Hungary was liberated from Turkish rule but the 150-year-long period left a permanent mark on men's wear. Oriental cut and technology can be detected in popular boots up to the end of the nineteenth century.<sup>10</sup>

## Characteristics of technology

After this review of changes in footwear between the thirteenth and seventeenth centuries, the next section focuses on manufacturing techniques used to make footwear at different periods. As might be expected, differences in form also involved technical changes.

### Shoemaking

In order to recognize technical details, it is essential to know the techniques that were used to make shoes in a given period. The leather was spread out by the shoemaker, who cut the pieces of the shoe so that they were suitably strong and the minimum amount of waste was produced. After the upper had been cut, the leather was shaped on boot lasts made of wood



CLOCKWISE FROM UPPER LEFT:

FIGURE 10 Men's leather stockings with matching sandals from the middle of the seventeenth century, HNM 1964.613.1.2.3.4.

FIGURE 11 Yellow leather stockings and slippers, detail of a painting, HNM 1611.

FIGURE 12 Men's footwear with iron heelpiece from the seventeenth century, HNM.

FIGURE 13 Men's footwear with leather-coated wooden heels from the seventeenth century, HNM, 1954.618.1.2.

FIGURE 14 Count József Csáky 1794, The Hungarian National Museum. The side-laced ankle-shoes became part of the Hungarian nobleman's attire.



to model the feet. However, they were not necessarily the exact shape of the foot but rather followed a certain fashionable shape. If the sole was cut symmetrically, the shoe could be worn on either foot. The soles and the uppers could be sewn from the face (the edge of the upper turned outwards) or from inside out; in the latter case, after sewing the leather was turned back (the edge of the upper turned inwards). During the assembly of the sole and the upper it is very important to leave no bare stitches on the sole as the threads would fray very soon during walking. There were several ways to protect the threads. If the shoe was assembled in a 'turn-shoe' construction, the seam was in the inner, protected side. If the shoe was sewn from outside, a groove was cut into the sole so that the thread was hidden and protected.

Seams were made with one or two needles. Seams with two needles are better because the resulting seams are more even and much stronger. In making shoes, awls were always used, and blunt needles; earlier even bristles were used. Sewing threads were twisted into the fibre ends of the bristles and they were fastened with tar and wax. Shoes were sewn with twisted linen thread which was tarred and waxed to make the thread smoother and water-resistant. Thicker threads were used for the soles; thinner threads were used for the uppers. A narrow, leather strip, triangular in section (known as a rand) was often sewn between the upper and the sole on the outer edge, in order to strengthen the stitches, which were made stronger and more water-resistant in this way. Heel-stiffeners and linings were often used inside the shoes. They were applied to stiffen

and strengthen the uppers made of soft leather (at the heels, toes, lace-holes); they also gave protection to the feet in places where seams, decorations and iron fittings could have hurt them.<sup>11</sup>

### The cut of soles

The sole of Western-type shoes was asymmetrical in the thirteenth and fourteenth centuries, the front gradually narrowing, often to a pointed toe. (Fig. 15) The 'waist' of the sole was gradually narrowing as well. The leather was not very thick; it was usually from calf or young cattle. Earlier some researchers thought that there were insoles in the shoes or the soles were pasted together from two layers of leather. After re-examining the finds we found, however, that the leather pieces thought to have been the sole and the insole were originally one piece but as a result of decomposition in the ground they had delaminated. This phenomenon is quite usual in archaeological leather finds (both soles and uppers), and it was probably due to a fault in manufacture.

From the late fifteenth century, the sole became more symmetrical, the toes were wider and rounder. The soles of Oriental footwear were always symmetrical. The forepart of the soles was often round with a pointed, slightly turned-up toe. The 'waist' was usually narrow; in certain cases it was extremely narrow, although sometimes it was straight. (Fig. 16) The sole leather of soft shoes was made of calf but for outdoors they were made of thicker, stiffer ox hide. A particular feature is that usually there are different types of stitch-holes at the front and at the back of the soles, because there were two different types of

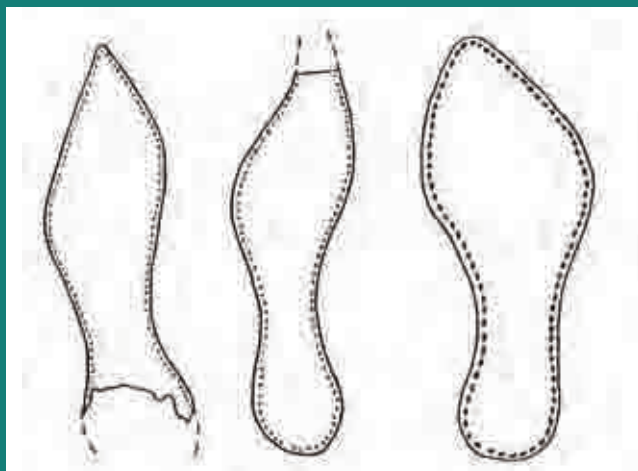

FIGURE 15 Typical Western sole types from the thirteenth to fifteenth centuries from the excavation sites in Buda and Tata.

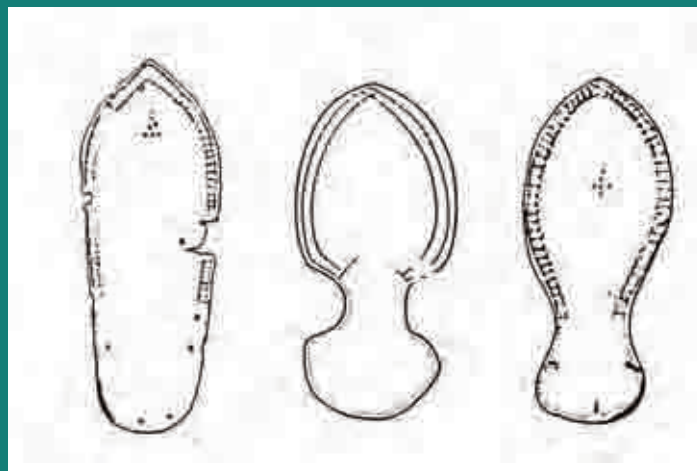

FIGURE 16 Typical Eastern sole types from the sixteenth and seventeenth centuries, Tata, Szolnok.

stitching used within the same sole in the Eastern type of footwear (see the description of stitching). The hard, Eastern type soles were often strengthened with iron nails and iron heelpieces at the back. As can be seen in Figure 17, this type of iron fitting was not only applied to boots but also to slippers.<sup>12</sup> The sole of the leather stockings very often had a peculiar mushroom-like shape. (Fig. 21)

### The cut of uppers

The upper of the Western-type shoes from the thirteenth-fifteenth centuries is asymmetrical, often of wrap-around construction, and it was usually sewn together on one side. This seam was usually in the inner side of the shoe and it was either perpendicular to the soles or it was slanted.<sup>13</sup> The vamp and the quarters were cut from one piece with small

inserts to make up the missing height or width. (Fig. 18) Low-cut shoes were often cut in a bent shape so that they would fit the feet well. Rands were often used between the soles and the uppers to strengthen the seam. (Rands are not the same as welts.) Calf or goatskin was used for the upper, as it was made of one piece, only soft leather could be used to ensure a good fit. Shoes were fastened with laces, latches, buttons or metal buckles. A tongue was often sewn into shoes which were fastened above the ankle which made the shoes more closed and more comfortable. Strengthening pieces were applied; stiffeners at the heel were typically triangle shaped, while at the lace-holes they followed the line of holes.

From the end of the fifteenth century, shoes were low-cut, their uppers were not made from one piece but they were made up of a vamp and quarters, which were cut symmetrically and they were sewn together on each side of the shoe. The quarters were often made up of two parts. The part of vamp closer to the throat was round or triangle-shaped. The shoes were slip-on or they were fastened with side latches from the leg part. The vamps were often decorated with slits or leather straps. Inside the heel there was always a leather stiffener, which followed the shape of the quarters. Similar ones were often used at the toe of the vamp, if the round shape was to be emphasized according to the current fashion, or the protection of toes was more important. At the end of the leather straps and the side seams, thin leather linings were applied to protect the feet. The upper was mostly of goat, calf or sheepskin. Sometimes the flesh side was turned outside, which gave a velvety, nappy effect to the shoes. (Fig. 20)

The complete uppers of Eastern type footwear, primarily boots, are rarely found in excavations because the larger pieces of leather were cut off and re-used before they were completely worn out. Nonetheless, their cut is clearly visible on the boots found in the crypts of the Parish Church of Sároszombat: it is symmetrical, sewn at the sides, and the leg-parts are knee-length. (Fig. 19) The uppers of boots and leather stockings were cut with a central axis and they were made of three parts: the vamp, the front piece and the back piece of the leg part. The leg parts were sewn on the sides. (Fig. 21) If the waist of the sole was very narrow, the vamp was shaped to make up the missing width at the sole. (Figs. 22 and 23) The upper was mostly made of goatskin. There were always stiffeners and linings in the vamp. The latter were cut of two pieces, typically long, up to the throat of the boot to protect the feet at the point where the vamp and the leg were sewn together. Slippers were cut similarly but instead of the leg part a low quarter was applied at the back. (Fig. 24)



FIGURE 17 Slippers with iron nails and heelpiece at the soles from the sixteenth century.



FIGURE 18 The cutting design of ankle shoes (see also Figure 3 ).

CLOCKWISE FROM UPPER LEFT:

FIGURE 19 Ladies' boots from the turn of the sixteenth and seventeenth century, HNM Rákóczi Museum.

FIGURE 20 The cutting designs of typical Western-type vamps, quarters and soles from the sixteenth-seventeenth centuries.

FIGURE 21 The cutting design of side-laced leather stockings, seventeenth century.

FIGURE 22 Boots, seventeenth century, detail. HNM 1954.617.1.2.

FIGURE 23 Cutting pattern of the sole and vamp of boots, seventeenth century. The missing width of the sole was made up with the special cut of the vamp.

FIGURE 24 Cutting pattern of a slipper, seventeenth century.

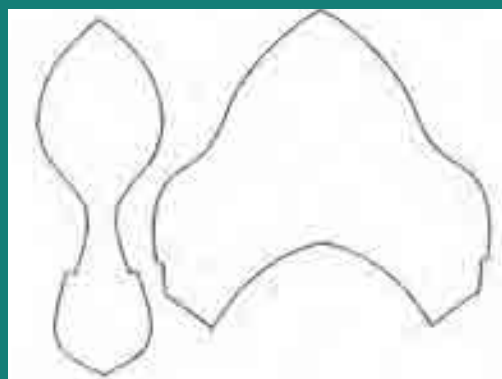
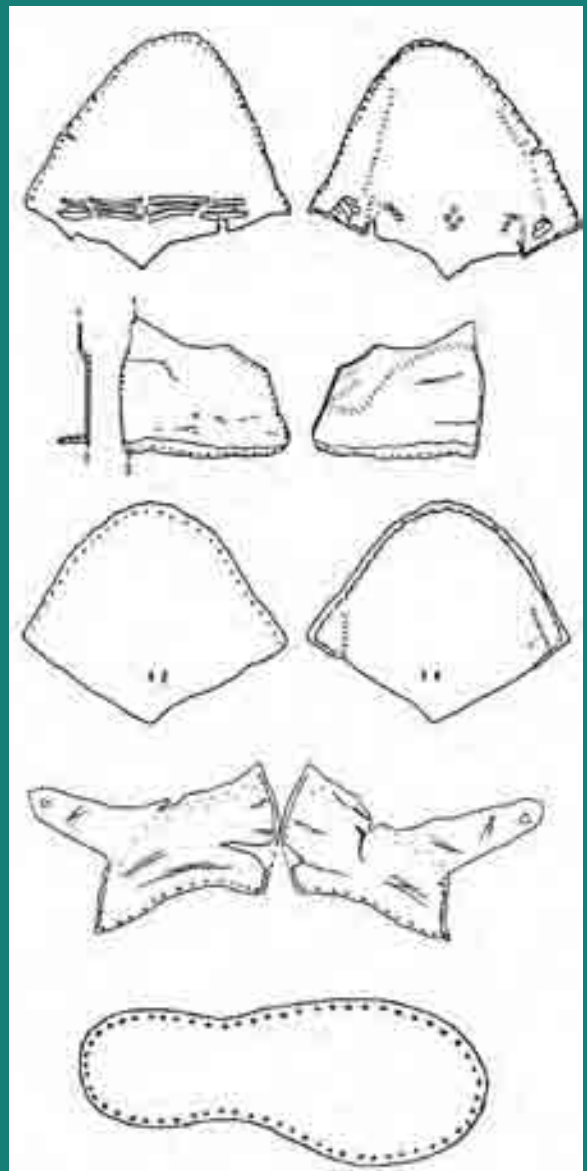

## Seams and stitching

It is impossible to introduce all the stitches and seams used in the given period, but the following list identifies those that are most typical in the Hungarian archaeological and historical finds. Figure 25 a-g shows the different types of seams.

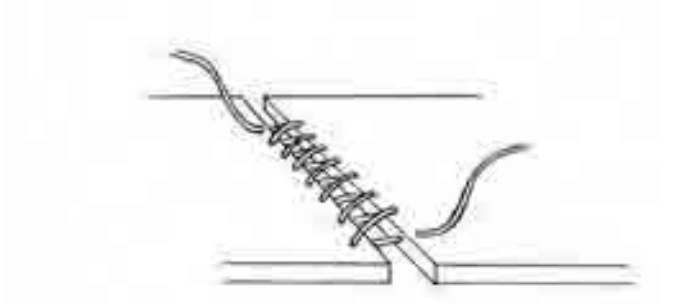

25a: Edge/flesh butt seam. Sewn with one needle, invisible from the face. It was used mostly to assemble the pieces of uppers.

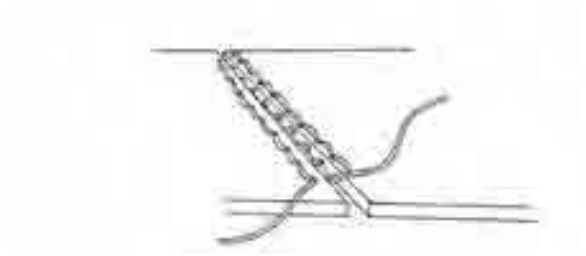

25b: Edge/flesh butt seam. Sewn with two needles, invisible from the face. It was used to assemble the pieces of uppers. It is stronger and more even than sewing with one needle.

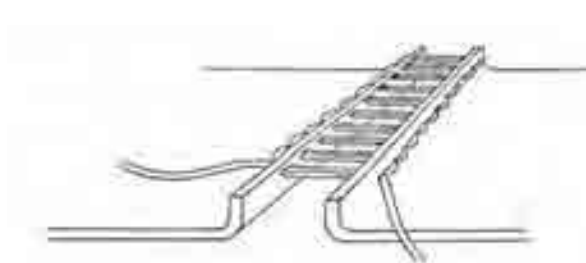

25c: Sewing with two needles: both pieces of leather with grain/flesh seams. It was applied in turn-shoe constructions when the upper was sewn to the sole inside-out.

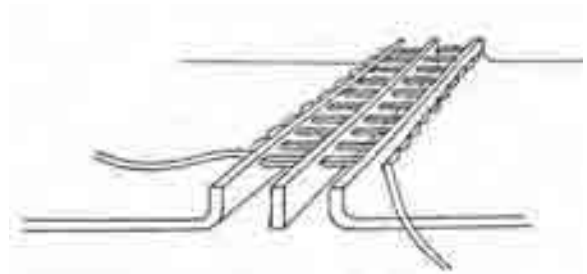

25d: Sewing with two needles, with rand on both pieces of leather with grain/ flesh seams. It was applied in turn-shoe constructions when the upper was sewn to the sole inside-out.

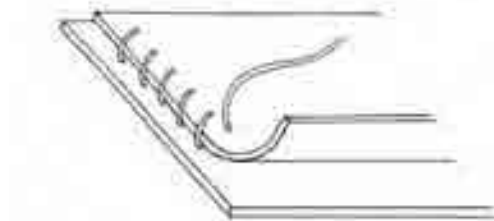

25e: Binding stitches with tunnel stitches: sewn with one needle. Stitches do not penetrate the leather completely so they are invisible from the outer side of the shoe. They were used to fasten stiffeners, linings, and lace-hole reinforcement.

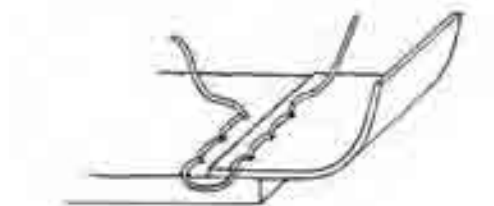

25f: Tunnel stitches in the sole, grain/ flesh seam in the upper leather. Sewn with two needles. It was applied in turn-shoe construction when the upper was sewn to the sole inside-out. The vamp of Eastern boots and slippers was attached to the sole with this stitching.

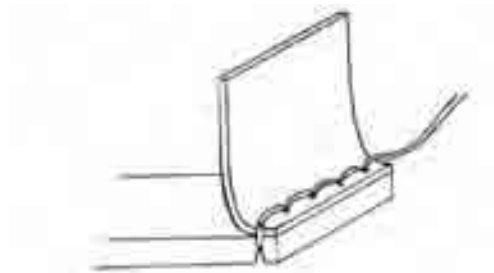

25g: Grain/flesh seams both in the upper and the sole. Sewn with two needles. There is a groove cut in the sole where the sewing thread is hidden. It was sewn from outside, not inside out. It was usual in the heel-parts of Eastern boots and slippers.

Between the thirteenth and fifteenth centuries, the uppers of Western-type shoes were sewn with edge/flesh butt seam from inside out, usually with one needle (25a), in some cases with two needles. (25b) The edges of leather were joined, the stitches did not penetrate the material completely, so they were invisible from the face of the leather. The assembly of the sole and the upper was carried out in a turn-shoe construction, using two needles (25c), but in case of children's shoes they could be sewn from outside as well. Rands were quite often used. (25d) Rands were usually 4-6 mm wide. Linings and stiffeners were sewn with binding and tunnel stitches inside the shoes (25e).

From the late fifteenth century, the vamp and the leg were joined with two needles from inside-out, with grain/flesh seams in the whole depth of the leather (25c). The assembly of the sole and the upper was carried out with two needles, mostly in turn-shoe construction (25c) but there have been some uppers found with edges turned out which indicate that the soles were sewn from the face. Linings and stiffeners were sewn with binding and tunnel stitches inside the shoes (25e).

The uppers of Eastern-type footwear were also sewn with edge/flesh butt seam from inside-out, but usually with two needles (25b). The assembly of the hard sole and the upper was carried out with two different stitches: on the fore part to the end of the waist a turn-shoe construction was used, with tunnel stitches in the sole (25f) then the shoe was turned back to the face and the heel was sewn with two needles from outside and the thread was applied in a little groove cut in the sole (25g). A different technique was used at the heel because the long-legged, thick-soled boots would have been very difficult to turn inside out if the sole had been sewn all around. The little part left open at the heel made it easier to turn the shoe inside out, and the remaining part was sewn from outside. It is interesting to note that slippers were sewn with the same seam although there was no specific reason for doing so. As the leather was very soft, the soles of leather stockings were sewn with the same stitches as for the assembly of the pieces of the uppers (25b). Linings and stiffeners of Eastern-type footwear were sewn with binding stitches just like Western-type shoes (25e).

## Summary

Our research has proved that most of the Western shoe-types from Hungary can be found in almost the same form in England, Germany, the Netherlands, and many of them in Poland as well. The Eastern types, which were popular in Hungary, were often found in Turkey and Russia, but they were unknown

in Western Europe. Some similar pieces can be found in Spanish museums but these were definitely imported by the Moors and did not become part of the aristocratic footwear as they did in Hungary.

This review is based on the objects we have examined so far. We would certainly like to continue our work. Our aim is to survey the complete material of Hungarian footwear from archaeological and historic finds, in order to get an even more detailed picture of the technologies of manufacture and compare the results with the typical features of European footwear in terms of production technology.

---

A shortened but unpublished version of this paper was presented at the ICOM CC Leather Working Group Conference, held 18-20 October 2000 in Vic, Spain, under the title: Kissné Bendefy, Márta, and Bakay-Perjés, Judit: *Western and Eastern influences on Hungarian footwear in the Middle Ages*.

## Acknowledgements

I would like to thank all those colleagues who have contributed to my project, primarily Judit Bakay-Perjés, with whom I have carried out the major part of this research. I am grateful to: the Hungarian National Museum, and its branch in Sáropatak, i.e. the Rákóczi Museum, as well as its branch in Visegrád, i.e. The King Matthias Museum; the Kuny Domokos Museum in Tata; and to archaeologist Dr. Dóra Nyékhelyi of the Budapest History Museum for their kind permission to publish various objects that have not been published before.<sup>14</sup>

## Endnotes and References

- <sup>1</sup> Judit Bakay-Perjés is the chief-restorer of the Budapest History Museum.
- <sup>2</sup> B. Szatmári, Sarolta: Előzetes jelentés a tatai vár ásátásáról [A preliminary report on the excavations at the castle of Tata] *Archaeológiai Értesítő* 1974: 45-53. Holl, Imre: *Mittelalterliche Funde aus einem Brunnen von Buda, Budapest*, 1966: 98. Órásné Melis, Katalin: A budavári Dísz tér 8. számú telken feltárt kút leletei [The finds of a well from the site at 8 Dísz Square]. Budapest régiségei 23. Budapest, 1973: 209. Gervers-Molnár, Vera: Sáropataki síremlékek [Finds from graves in Sáropatak]. *Művészettörténeti Füzetek* 14. Budapest 1983: 101.
- <sup>3</sup> Szalay, Zoltán: Régészeti és történeti eredetű bőr lábbelik konzerválása [The conservation of archaeological and historic leather footwear]. *Múzeumi Műtárgyvédelem* 1. Budapest 1970: 127-168. Virág, Lajosné: Bőr- és faleletek konzerválása és restaurálása [The conservation and restoration of leather and wooden finds] *Budapest régiségei* 23. Budapest 1973: 211-218.

- 4 Goubitz, Olaf: The drawing and registration of archaeological footwear. *Studies in Conservation* 29 (1984): 187-96. Goubitz, Olaf: Calceology: a new hobby: the drawing and recording of archaeological footwear. In: *Recent Research in Archaeological Footwear*. Association of Archaeological illustrators and surveyors, Technical Paper No. 8. Northampton, 1987. Grew, Francis; de Neergaard, Margrethe: *Shoes and pattens*. Museum of London 1988: 145. Goubitz, Olaf; van Driel-Murray, Carol; Groenman van Waateringe, Willy: Stepping through Time. *Archaeological footwear from prehistoric times until 1800*. Stichting Promotie Archeologie, Zwolle 2001: 396. Schnack, Christiane: *Mittelalterliche Lederfunde aus Konstanz (Grabung Fischmarkt)* Stuttgart, 1994: 105.
- 5 Bakayné Perjés, Judit; Kissné Bendefy, Márta: *XIII.-XVI. századi bőr leletek technikatörténeti és technológiai vizsgálata* [Studies in the technology and technological history of leather finds from the 13<sup>th</sup>-16<sup>th</sup> centuries]. Záróbeszámoló. OTKA T.021204 számú Kutatási Pályázat 1996-1999, Budapest, 2000.
- 6 Gáborján, Alice: A szolnoki hódoltságkori ásatási lábbelianyag magyar viselettörténeti vonatkozásai [Footwear from the excavations in Szolnok from the period of the Turkish Conquest and its references to the history of Hungarian clothing]. *Ethnographia* LXVIII, 4. Budapest 1957: 543-570. Órásné Melis, Katalin: A budai középkori lábbeliviselet, XIII.-XIV. század. [Mediaeval footwear in Buda, 13<sup>th</sup>, 14<sup>th</sup> centuries]. *Archaeológiai Értesítő* 1973: 88-101. Órásné Melis, Katalin: Régészeti adatok a későközépkori lábbeliviselet kutatásához [Data for the studies of late mediaeval footwear]. *Archaeológiai Értesítő* (1974): 275-289.
- 7 Írásné Melis, Katalin: 1973, op cit. HOLL, Imre: *K szeg vára a középkorban* [The castle of Kőszeg in the Middle Ages]. Fontes Arch. Hung. Budapest 1992 p.67. Mocskonyi, Melinda: Lábbeliviselet a XII.-XIII. századi Sopronban [Footwear in Sopron in the 12<sup>th</sup>-14<sup>th</sup> centuries]. A Sopron -Előkapui bőrleletanyag feldolgozása. In: *Soproni Szemle* (1997): 335-355.
- 8 B. Nyékhelyi, Dorottya: Découverte d'un puits médiéval Place Saint-Georges. In: *Un château pour un royaume. Histoire du château de Budapest*. Katalógus. Musée Carnavalet, Histoire de Paris. 15 juin-16 septembre 2001. Paris 2001. (The conservation and detailed documentation of the footwear is in progress, publication is due later. )
- 9 Yarwood, Doreen: *The Encyclopaedia of World Costume*. London, 1978: 471.
- 10 Gáborján, Alice: op. cit.
- 11 Swann, June: *Shoemaking*. Buckinghamshire 1986: 32. Brezovcsik, József: *Kivesz ben lév cipé kézművesipari technológiák* [Disappearing technologies in shoemaking]. Bőripari Tudományos Egyesület Kiskönyvtára nr.IV., Budapest 1960: 66. Grew, Francis; de Neergaard, Margrethe: op. cit.
- 12 A Turkish illustration, In: *Istanbul in the 16<sup>th</sup> century*, Akbank Culture and Art Publication, Istanbul 1994.
- 13 Írásné Melis, Katalin: op. cit 1973.
- 14 The photographs were taken by Gábor Nyíri and Judit B. Perjés, the sketches were made by Márta Kissné Bendefy and Andrea Láng.



The [Hungarian] Museum of Military History commemorated the 150th anniversary of the Hungarian Revolution and the War of Independence 1848-49 with a large-scale exhibition in 1998. Several relics from that period were restored, including two atillas: Hungarian-style braided military coats. One atilla belonged to Ernő Kiss (1800-1849), the Martyr of Arad; the other to Richárd Guyon (1812-1856), a Hungarian General of English descent. (Figures 4-5, and 6-7)

[ MÁRIA KRALOVÁNSZKY ]

## Problems of the second restoration of two general's atillas (military coats) from 1848-1849

**B**oth atillas are made of pale-blue wool broadcloth with golden braiding and red felt cuffs. The lining of Ernő Kiss's coat was completely missing. Richárd Guyon's atilla was lined with white silk above the waist and with red wool below. The pale-blue wool cloth of both atillas was rather moth-eaten with lots of smaller or larger holes which had been previously restored. Unfortunately no documentation could be found of the restoration, so it is not known when or by whom the atillas were stabilized.

The restoration of Ernő Kiss's coat had involved gluing and sewing in some areas (Fig. 1), while the other coat had only been sewn. In the former case, underlay-patches, some just the size of the holes or slightly larger, had been glued in place. The patches were cut from grey and blue fabric or blue silk in some cases. The patches, which were sewn to the fabric with a few stitches, were held firmly by the glue which must have been soft originally, but is now extremely hard. Tiny holes were simply pulled together with thread.

During the sewn conservation of Richárd Guyon's atilla, patches of blue rep fabric were placed under the holes, and the edges of the holes were stitched to the cloth with a conspicuous thread in a radiating pattern which looked almost like embroidery (Fig. 2). Certain parts of Ernő Kiss's atilla had been undone to make the underside of the cloth accessible for gluing. In contrast, in the case of Richárd Guyon's coat, none of the original construction was undone because the patches were tucked into the holes and then sewn to the wool cloth. However, the quilting, the interlining, all the layers and even the silk lining had been sewn together when the patches were sewn in place.

The pale blue cloth of the atillas is of a plain-weave, fullered wool with a smooth, felt-like surface; the latter is achieved by raised the nap of the wool, shearing the nap, and combing the shorn surface in one direction on the face of the fabric. This results in a material which is thick, compact and rigid. The new wool fabric selected for the recent conservation treatment was imported from Italy. It was made of

FIGURE 1 Sewn and glued patches on the underside of the sleeves (The atilla of Ernő Kiss)

FIGURE 2 The holes in the cloth after supporting and sewing (The atilla of Richárd Guyon)

FIGURE 3 The atilla front, after removal of the patches (the atilla of Ernő Kiss)

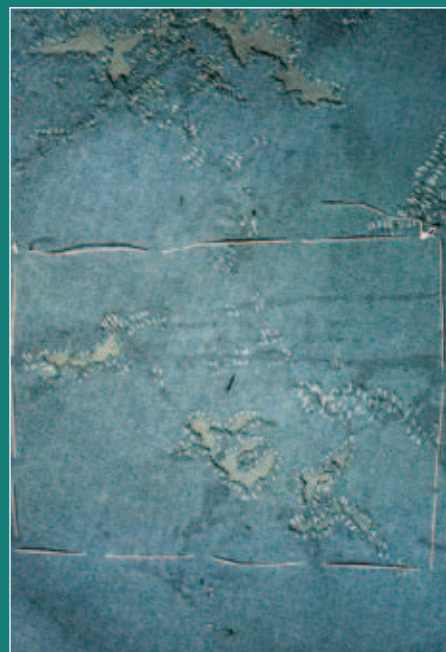

pure wool but with a twill weave; the nap was raised only on the face of the cloth and it was unshorn, and thus the surface was uneven and irregular. The cloth was also thin and soft. The fulled wool cloth used to make the atillas was woven from blue and écru fibres spun together, resulting in a streaked colour on the surface. The new wool fabric was originally white, making it easier to dye, but this made it impossible to reproduce the streaked colour of the original cloth. Lighting, therefore, affects whether or not the new wool fabric blends well with the cloth of the atillas.

## The conservation of Ernő Kiss's atilla

The atilla had to be partly, and later completely, dismantled in order to remove the glued patches of the previous restoration (Fig. 3). The golden braids were unstitched as well, since there were moth holes underneath the braid and it was easier to clean and support the moth holes that way. The only substance that dissolved the glue was acetone but even that was only effective on the surface layer; it was ineffective where the cloth was deeply impregnated with glue. The wool was cleaned in an aqueous solution of a non-ionic detergent (Prewocell).

The cloth was so thick that placing patches of new cloth behind the holes would have resulted in deep shadows on the surface. For this reason,



a patch-implantation method was selected by the author. The implant was cut (from the new, suitably dyed cloth) to the size of each hole and secured with a thin cotton thread with closely placed, invisible stitches worked within the whole depth of the fabric, from the underside. (Figs. 8 -9) All the holes visible to the eye and the larger gaps (2184 of them) were in-filled in this way; then a full support of thin wool cloth was sewn to the underside. (Figs. 10-11)

FIGURE 4 The atilla of Ernő Kiss before conservation



FIGURE 5 The atilla of Ernő Kiss after conservation



FIGURE 6 The atilla of Richárd Guyon before conservation



FIGURE 7 The atilla of Richárd Guyon after conservation



The incorrect seams of the previous conservation were corrected during the re-assembly of the atilla. After the original interlining was put back, the braiding was sewn on again. The original quilting of the chest area, which was marred by moth frass, was not retained but was re-made from cotton wadding, imitating the form of the original. The lining was missing, so a new one had to be made. Richárd Guyon's atilla provided a model for the lining; thus, the upper half to the waist, as well as the sleeves, of Ernő Kiss's atilla were lined with twill-weave silk while the bottom half and the front row of buttons were lined with red wool cloth.

## The conservation of Richárd Guyon's atilla

The coat had to be completely dis-assembled so that the patches of the previous repair could be removed. The braids were taken off, cleaned and repaired as well. The wool cloth was washed in an aqueous solution of a non-ionic detergent (Prewocell). The wool cloth of Guyon's atilla is much thinner than the

other atilla and there were more, rather tiny holes in it.

Thus the implantation method was ruled out, leaving the option of supporting and sewing around the holes. The edges of the holes were secured with thin silk thread after the new, suitably dyed cloth was placed under the original fabric. The thread disappeared into the raised surface of the fulled wool cloth, resulting in a beautiful, even surface. (Figs. 12-13)

The original form of the atilla was reconstructed by relying on the findings of the dis-assembly. The original interlining was repositioned, and the braiding was sewn back. The moth-eaten, defective quilting was replaced with new cotton wadding. Guyon's atilla was thickly padded not only in the chest but also at the shoulders and shoulderblades. The next step was to restore the lining. The silk lining of the upper half had been sewn all over, was full of holes because the previous repair to the wool cloth reached deep into the linings and interlining; there were also repairs to the torn silk

After consultation with the curator, the old lining was replaced with a new one; the original has been

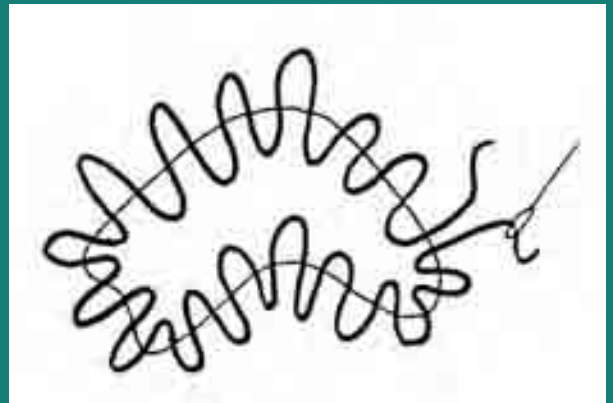
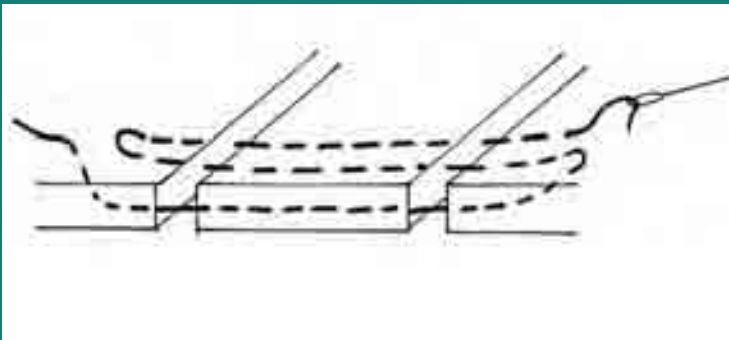

CLOCKWISE FROM UPPER LEFT:

FIGURE 8 The invisible stitches worked in the depth of the fulled wool cloth

FIGURE 9 The fastening of the implant from above

FIGURE 10 The fastening of the underlay fabric on the underside of the fulled wool cloth

FIGURE 11 Areas where the underlay fabric was tacked onto the face of the atilla

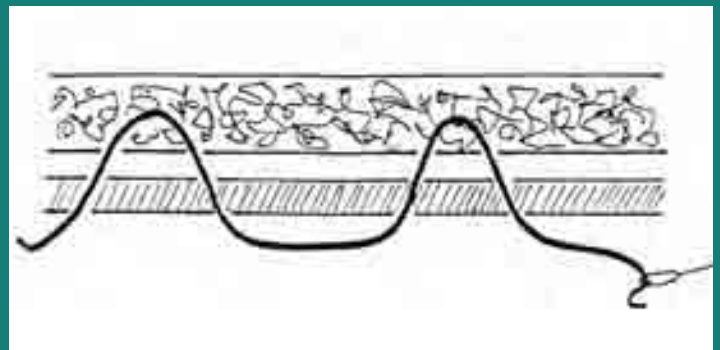

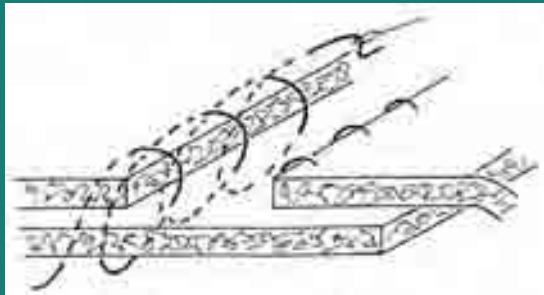
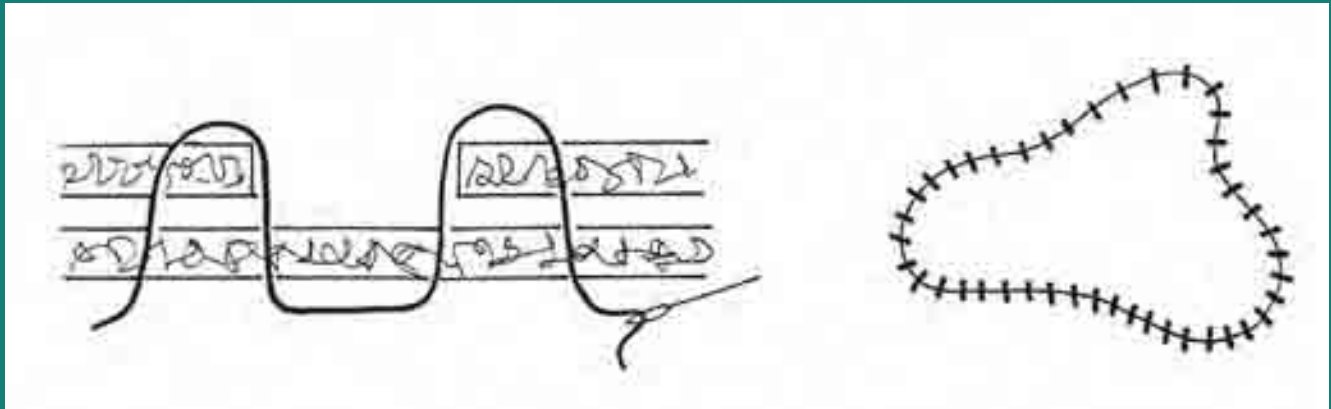

FIGURE 12 Stitching the edges of supported holes in the fulled wool cloth

FIGURE 13 Section and top view of the supported and stitched holes



retained for record purposes. The red wool lining of the lower part of the atilla was ragged, friable and imperfect. It would have required a full support and extensive stitching, and even then the fraying threads of the cloth would still have been obvious. It was therefore decided to cover the old cloth with a new one. The original fabric was secured with several lines of tacking stitches to the new one. Should there be another conservation treatment in the future, the original lining, now concealed inside the atilla, could be uncovered and restored in a better and more efficient way.

Choosing the right support and infilling material is likely to remain problematic even in the long run, because although suitable natural fibre textiles are available, they differ in texture, quality and dressing from the old ones.

## Questions and problems raised during conservation

The atillas of Ernő Kiss and Richárd Guyon may not have been restored to their original magnificence, but they have at least become cleaner and more aesthetically pleasing. In the event of further conservation in the future, the dis-assembly of the original garments and removal of the supporting and infill materials

will be much easier, particularly as there is detailed documentation about the process.

Still, the question remains, why had the atillas been restored in that particular way? The demands of conservation and the science of conservation have changed radically in the past fifteen to twenty years, so we should not judge the work of our professional ancestors in the light of current views. One day our methods may also seem outdated or even incorrect. Let us think in advance about the judgement of our work in twenty years' time. Might the methods used in the first conservation of the two atillas have been cutting-edge solutions in that time?

Might the colours of the threads and patches have blended well before they faded? Or could the supporting and infill patches and the stitching have been selected on purpose to make them conspicuous? Was the choice of patches so different from the original cloth a matter of choice or did they just not have any other suitable material?

The method of gluing must have been a quick and modern method in its time, but since then it has turned out that this glue must be applied with utmost caution. The conclusion from these atillas is that for clothing, where the textile has to 'move' or bend, gluing should be avoided.

A glued surface cannot follow such motion: it either breaks or comes off. Each type of textile,

especially this kind of fulled wool cloth, can be sewn, as shown by the unglued atilla. Gluing should also be rejected because it damages the cloth if it cannot be removed. In our case, when the glue stuck to the raised surface of the wool it was possible to remove it with acetone but when it impregnated the cloth it was impossible to dissolve. Unfortunately these areas had to be cut out in order to allow them to be replaced with the new support and infill fabrics.

Another warning for sewing conservation is that when patches are tucked in behind holes and then stitched in place, the underlying layers of fabric (e.g. interlinings and linings) can be caught up by the stitching. The patches either have to be sewn very carefully or the lining has to be undone to give access to the underside of the material.

In Austria today, academic training in conservation and restoration is offered at two institutions: the Academy of Fine Arts and the University of Applied Arts, both located in Vienna. Conservation training at the Academy of Fine Arts has a long tradition; its roots can be traced back to 1829 when the famous Austrian painter Ferdinand Georg Waldmüller, then Director of the Academy's Picture Gallery, suggested such a school, though it was not implemented until 1908 when the first specific courses were available. The art historian Robert Eigenberger (who was also Director of the Picture Gallery) established the full training programme in 1934.

[ GABRIELA KRIST ]

# Academic training of conservator-restorers in Austria:

## PAST EXPERIENCES AND FUTURE PERSPECTIVES

---

The primary goal of the Chair for Conservation and Restoration Technology was research into the history of painting and sculpture. The first diplomas were awarded in 1937. Graduates were expected to be primarily responsible for the restoration of works of art in state collections and to be employed in museums and collections. Eigenberger headed the Master Class until 1965; this was the professional cradle for a whole generation of leading Austrian conservator-restorers. Eigenberger's successor (and also student) was the art historian and restorer Helmut Kortan (1965-86). He recognized the need to add paper conservation as an additional focus to painting and sculpture restoration. Gerald Kaspar held the chair from 1986-93, and altered the name to the Master Class for Restoration and Conservation, which has been maintained by his successor Wolfgang Baatz who assumed the Chair in 1994.

This extensive experience in academic training for art conservators has placed Austria in a leading position in Europe. In 1933, the Courtauld Institute of Art, UK and in 1937 the Institute of Archaeology, University College London, UK began formal teaching of conservation in London. In Italy, Rome's Istituto Centrale del Restauro was established in 1939, although actual courses were not held until after the Second World War. After the war ended, the extensive damage throughout Europe considerably increased the demand for trained conservators, and led to the establishment of numerous new schools, including the Academy of Fine Arts in Prague, Czechoslovakia, and the Torun University and Academy of Arts in Cracow and Warsaw, Poland.

The general spirit of new beginnings also engendered pertinent professional organizations. In 1959, The International Centre for the Study of the

Preservation and Restoration of Cultural Property (ICCROM) was founded in Rome as a centre for international education and continuing education for conservators working with objects, monuments and sites. Earlier, in 1948, another UNESCO initiative fuelled the establishment of the International Council of Museums (ICOM) as the international umbrella organization for museums. Similarly, the International Council on Monuments and Sites (ICOMOS) was set up in 1964, originally intended as a professional society for architects and architectural engineers, but today a forum for discussions concerning all the professions working with monuments preservation. During the second half of the twentieth century, these international organizations have spearheaded the development of conservation and restoration as a profession in itself.

But to return to Austria: at the 'Angewandte', which grew out of the Museum for Applied Art (angewandte Kunst) at the end of the nineteenth century, issues of conservation and restoration were not raised until much later. The former Master Class for Work in Gold and Silver, Glass and Enamel provided the core courses in the early days. Established in 1964, it was headed by the conservator and goldsmith Otto Nedbal until 1974. In 1980, Hubert Dietrich joined the Angewandte; as the head of the Paintings Conservation studio at the Kunsthistorisches Museum, he expanded the Angewandte's traditional focus on metals to include painting conservation. It is to his credit that the long tradition of Austrian paintings conservation, as practiced at the Kunsthistorisches Museum by Josef Hajsinek (Chief Conservator 1939-68), was continued and incorporated into the academic training programme.

Dietrich headed the Master Class until 1999. New education legislation bestowed university status on the former Hochschule für angewandte Kunst. This necessitated considerable internal re-structuring; the former Master Classes were re-named as 'Chairs' and Departments and arranged into pertinent institutes. Today, the Chair for Conservation and Restoration has been linked with the scientific and technical laboratories to form the core of the Institute for Conservation Sciences and Restoration - Technology. Since the new legislation also included changes to the course of studies, a new curriculum had to be devised; this took effect in October 2001 at the Angewandte. This also occasioned organizational alignment with the Academy of Fine Arts, in particular the creation of new and necessary courses which had been discussed for decades and for which preservation authorities for museums and monuments had long been calling.

Today, the Angewandte offers the following tracks for specialization: conservation and restoration

of paintings, objects, textiles, stone and archaeological finds. At the Academy of Fine Arts, the specialist areas defined for conservation training courses are paper, wall paintings, polychrome sculpture and, overlapping or parallel to the Angewandte, paintings. Both Austrian programmes require 10 semesters and a terminating Diploma exam; successful candidates are awarded a Master of Arts, a title which in Austria is equivalent to that of other academic disciplines, i.e. which affords professionally and financially equal ranking to other university graduates in the Civil Service. Many other countries envy us for this achievement.

The basic courses (during the first section) at the Angewandte focus primarily on technical and artistic requirements. For all the specialist areas, this includes basic courses in drawing (from nature), painting techniques, wood-working and tools. Depending on the individual needs of each special field, there are further required courses, e.g. introductory weaving for textile conservators or basic stoneworking techniques for those specializing in stone.

The practice of conservation is defined as the core artistic subject material for individual training, and is the basis for teaching throughout the five years. Right from the beginning, students learn on original works in the atelier. Learning by observing, by recognizing the technical and technological structure of the objects as well as the damage which might have been caused by age, handling and/or inherent material degeneration are always primary topics during the first semesters. Teaching conservation practice extends from conveying simple techniques and preventive measures for care to dealing with the complex restoration problems that are the emphasis of the later semesters. During the fifth year, students select an object for their Diploma project, an item which presents a gamut of conservation challenges as well as offering possibilities for theoretical formulation.

It goes without saying that the artistic and art-historical aspects are also considered within the framework of the Diploma project, as well as all the pertinent scientific examinations (to be carried out independently as much as possible) for the clarification of technological problems and causes of damage. Theoretical coursework in the liberal arts and sciences complement the practical work experience in the curriculum. All areas of specialization have defined the joint required coursework, such as colour theory, pigment chemistry or an introduction to materials, as well as lectures in art history and business and management skills for conservators. The added advantage of close cooperation with the scientists on the staff is considerably aided by the fact that



their laboratories are located in the same building. Furthermore, the specialists and well-equipped laboratories for wood, textile and metal technologies are available to assist students and teaching personnel.

There is also a well-established cooperative link with leading Austrian institutions in the field, especially with museums and with the Austrian Federal Office for the Care of Monuments: its restoration workshop at the Arsenal has not only provided pertinent space and infrastructure for the establishment of the stone conservation specialization, but also offers students interesting practical work experience in Vienna and the provinces. Museum collections in Vienna also function as clients and include the Institute for Conservation in their current projects, e.g. for installing and dismantling exhibitions.

The planning of the courses for textile conservation started about ten years ago and was, to a large extent, always based on the advice of my friend Ágnes Timár. Her extensive international experience in the training and continuing education of conservators, particularly in practical application of scientific methods, was an important resource for the establishment of our new study programme. A long-time friendship and professional association came to a sad close with Ági's death; it therefore gives me particular pleasure that her spirit lives on and continues to develop in the budding textile conservators, as well as in my memory.

In the years leading up to the turn of the twentieth century, as in other fields of the applied arts, wide-ranging changes took effect in the European art of lace making. These changes were twofold. On the one hand, there was a drive to reinvest the technique with artistic values of a more expensive, but also personal approach that posed handcrafted sewn lace and bobbin-lace as an alternative to the onslaught of industrial manufacture. On the other hand, the line of change took inspiration from naturalistically or geometrically portrayed motifs of flora and fauna, often invested with symbolic meanings, which bred a new form of art to replace the variety of the baroque and rococo motifs. The style of women's clothes at the turn of the century paved the way for the flourishing of lace-work. Fans, frills, collars, cuffs, decorative kerchiefs and parasols embellished costumes for all occasions as accessories, to which we can add two elements of Hungarian gala dress, the woman's apron and tie-frills for men.

EMŐKE LÁSZLÓ

## Lace from the Secession (Hungarian Art Nouveau):

SEWN, COLOURED LACE ARTICLES

The design and preparation of lace was taught in all the schools of applied arts in the UK, France, Belgium and Austria. The designs relied on various early techniques (e.g. Alençon, Brussels, etc.), but their motifs called to life the stylized bird figures and flora of the Secession. A few examples picked from European art of lace-making illustrate the transformation described above, and the completely new perception. A design for a fan by Annie Stook (Taunton, Great Britain) won a silver medal at the English National Competition of 1898 and can now be found in the collection of the Museum of Applied Arts in Budapest.<sup>1</sup> Exploiting the possibilities of the alençon for minutiae and

detail in rendering, the designer depicts a dreamlike garden. She combined the fantastic floral patterns, bird figures and willowy style of the line-drawing characteristic of the Secession with an ornamental surface presentation. The decorative motifs of the fan rise out of the fine, hexagonal base net, and combine with other lace stitches only between blooms and above ground level, enriching the wings of the butterflies and the leaf veins with a complex web of geometrical forms.

In the years following the turn of the century, similar compositional devices are found in lace fans, especially those of French and Austrian design. A much simpler, more stylized version of lace-work in

fans can be observed in lace of the Austrian Hoffmanner's design (Gossengrün School).<sup>2</sup> The border is of wild roses whose stems descend down the radials, or weave around it and branch out. It is sewn lace once again, connecting the patterns at the base of the radials with an airy, light web. Professor Unger designed a sewn lace collar<sup>3</sup> for the students of the School for Lace-work in Graslitz. This is similar to the phlox, with the stems of many little blooms dextrously bending and connecting across the lace.

The great personality of Austrian lace design was Lady Hrdlicka, with work for both the Galician and Gossengrün Schools of Lace. Among her collars, fans and handkerchief trimmings of lace, the seam lace merits special attention for the similarity of its composition to Hungarian lace of the time. The upper edges of these compositions have either a wavy line of flower stems, or a straight line from which the stems curl out. Her lace depicting a row of pineapples is a good example of the first, and a seam lace with a bevy of little flowers (phlox), a row of their blooms, is of the second composition.<sup>4</sup> The fact that most lace of the new style, the Secession, is sewn lace is interesting, but also probably not a coincidence. For this technique is much less restrictive, giving free rein to the often luxuriant depiction of flora and fauna, leaping arches and tendrils.

The years preceding the turn of the century also saw the Hungarian publication of the journal *Művészi Ipar* [Artistic Trades], and later *Magyar Iparművészet* [Hungarian Applied Arts] (1897 onwards) reporting on current events in the applied arts both at home and abroad, international and global exhibitions, Christmas exhibitions and spring shows, with profuse illustration to complement the written accounts. The pattern papers (such as the pattern-papers of the weaving and spinning crafts) were soon to follow with a wealth of published patterns drawn by European and Hungarian designers for damasks, embroideries and lace in the main. In this way Hungarian designers could follow designs not only by their European colleagues, but also by their fellow contemporary Hungarian artists. Classes for the cottage industry were formed at the Women's School of Applied Arts and the School of Applied Design, Budapest, where various techniques of embroidery and lace-work were taught in addition to weaving. As in many parts of Europe, the sewing of lace and making of bobbin-lace was a part of the cottage industry in Hungary; it not only provided work opportunities for girls and women in villages, but also had the goal of keeping folk-art alive and in the public eye.

Béla Angyal (1847-1928) established the National Bobbin-lace Making School of Körmöcbánya in

1882, with the same aim. However the revival of the heritage of flax, or more rarely metal-threaded bobbin-lace making in the highlands, had already begun a decade earlier. He first had seam-lace of extremely simple design made in the villages of the regions under the supervision of his sister, and then revived the motif treasures of the 'floral renaissance' in his own designs. These lace articles won him a prize at the Paris World Exhibition of 1900<sup>5</sup>, and later in Turin, Milan, and Brussels. Though exceptional pieces of Hungarian lace, in terms of both technical and artistic merit, can be found among the historicizing lace works, the new style of the Secession did not register in his work.

Later, others also came to prepare designs for the lace workshop, including István Gróh (1867-1936), a teacher at the School of Applied Arts. He considered decorative Hungarian folk art and the possibilities for its use in the applied arts on a theoretical basis in a number of his books. One of his lace works, designed for the 1906 international exhibition of Milan, was a collar<sup>6</sup> that employs a 'sleeved' motif of the old bobbin-lace from Gömörmegeye and Csallóköz creating a surface of charged lines and a symmetrical composition while encircling the motif in foliage. The piece of bobbin lace bearing the stylistic marks of the Secession was in all probability a one-off initiative among the works of bobbin-lace to be made at Körmöcbánya, with no known work similar to it among the products of the workshop that closed during the First World War.

The creation of the type of lace particular to the Hungarian Secession, the lace of Halas, is attributed to the designer Árpád Dékányi (1861-1931) and the lace maker Mária Markovits (1875-1954). The first pieces of lace made in this style made a debut at the Christmas exhibition of the Hungarian Society for the Applied Arts in 1902. The designer of the lace was an arts teacher of Kiskunhalas, an originator of the Hungarian cottage-industry movement.<sup>7</sup> To complement his teaching he joined with great enthusiasm the movement, which had as its goal the widening of knowledge about folk art and the collection of its remnants and motifs. Besides adding a style to the applied arts in Hungary with the creation of the lace prepared with 'authentic Hungarian patterns and an original new technique', as a member of the movement he wanted to provide work opportunities for the girls and women of the region.

The production technology of the sewn lace of Halas differs from European types of sewn lace. Its peculiarity is enhanced by the fact that, especially in the first decade of the workshop's operation, it

was very often made with coloured silk thread. The motifs of the lace from Halas are encircled by a rather pronounced outline. This outline thread was at first made from the same yarn as the base lace, but later a ready-made outlining thread was procured. In contrast to the classical net stitches for the filling of motifs, sewing stitches are used here. The filling was perfected to such a degree that it could be compared with the finest cambric. At first rough, but later a diaphanous, un-whitened flax yarn is used for the lace. Unlike a variety of other lace, the designs of Dékány are carried out in coloured thread; in rare cases metallic thread is also used for ornamentation. The use of silk thread was rather rare in the European tradition of lace-making; among the most famous of this type is possibly the Spanish Chantilly lace of the nineteenth century.

A particular curiosity of the silk lace from Halas is that in producing a field of colour, two threads might well be combined. Grey and red threads are

combined in this manner for the lace trimming with paprikas depicted whole,<sup>8</sup> (Fig. 1) and a soft vibration of the red colour is achieved. Another version of colour-play can be observed in the instances of lace done in pastel colours, in that of the wild hyacinth lace trimming,<sup>9</sup> (Fig. 2) or the lace fan<sup>10</sup> with the peacock design for example, (Fig. 3) where stronger and lighter shades of the same colour are combined. The stitches holding the decorative motifs of the first articles of lace are rather simple. A bar-like or meshed is frequent, with ornamentation in spider stitches. Ten, fifteen types of connecting stitches were used in the earlier years as Mária Markovits<sup>11</sup> remembers. The simplicity of the connecting stitches emphasized the motifs of the lace by contrast, and enhanced their decorative presence.

Lace designed by Árpád Dékány can be classified into three groups on the basis of the motifs used: trimming, collar and frill lace with floral patterns; trimming lace and lace fans with patterns of fauna;



FIGURE 1 Lace trimming with paprika patterns, 1903 (detail)



FIGURE 2 Lace trimming with hyacinth patterns, c. 1906 (detail)

FIGURE 3 Lace fan with a peacock, 1903



bags, fans and covers decorated with boys and girls dressed in traditional costumes, often a depiction of a folksong or story. His thin lace trimmings of floral and fruit patterns are composed of a row of motifs drawn from the paprika, flower buds, pomegranates, tulips, daisies, wild hyacinths, morning glories, strawberries, cherries, snowdrops and water-violets. The colours used are red, faded-green, faded yellow, orange, green, pink, grey, bluish-grey and white. The thread outlining the motifs is usually black or white. The slightly swaying stems of flowers or fruit, with stylized foliage, emerge from a lobed or straight upper hem edging.

Stylized foliage<sup>12</sup> (Fig. 4) embellished<sup>13</sup> with motifs that conjure stag-horns (Fig. 6) and heart, lace frog or braids (Fig. 6) make up the patterns for wider strips of lace made as trimming for either church or regular covers, or those<sup>14</sup> (Figs 4 and 5) made to adorn women's dresses or shawls, whose compositions are reminiscent of the way hung jewels are built up in the style of the Secession. Their colour is of a softer tone, and the outline is less pronounced. In this group of works, attention is summoned by a collar, which is covered all over in poppy-flower stems, merely as a result of its size. A rich play of lines formed by stems with flowers in bloom or already waning, lobed leaves, globes formed of pistils, and capsular fruits weave a net over the whole collar. The outer hem of the lace is also lobed, with an ornamentation of small bows.<sup>15</sup> (Fig. 7)

Stags, peacocks and doves populate lace works with figures of animals. These patterns are either arranged by the designer in the manner of composition continued since antiquity, where the animals are depicted in symmetrical, reflected pairs<sup>16</sup>, (Fig. 8) or following the composition of other lace trimmings, are set in a row. Each of the three animals has symbolic significance and is a very popular motif in Hungarian folk art. The peacock facing forward with its tail spread is a typical motif of the applied arts in the Secession, and can be found in almost all its genres. Dékányi combines the folk costumed youths and girls in his figural lace pieces with the playful line characteristic of the Secession. Two of the earliest pieces among these, the trimming which repeats the figure of a girl dancing<sup>17</sup> (Fig. 9) and a lace fan held in an Australian collection at present<sup>18</sup>, were lace sewn with coloured silk yarn, while the later ones are of flax.

The lace workshop set up in Halas in 1903 achieved great success both at home and abroad even in its first years. Besides various prizes in Hungary, it won the Grand Prize at the 1904 World's Fair in St. Louis<sup>19</sup>, and was shown at the International exhibitions of Venice in 1905 and Milan 1906, where it



FIGURE 4 Lace trimming, 1903

FIGURE 5 Lace trimming, 1903

FIGURE 6 Lace trimming with stag-horn and braid patterns, 1903

won another Grand Prize. Árpád Dékányi was posted to Budapest and charged with the organization and direction of the lace industry throughout Hungary in the autumn of 1906. Among his immediate successors, Ernő Stepanak and Antal Tar are worthy of mention. Although Dékányi continued to design Halas lace as reported by the volumes of *The Studio* from 1908 and 1910<sup>20</sup> among others, his connection



FIGURE 7 Collar, c. 1905

FIGURE 8 Lace trimming with a pair of doves pattern, 1902

FIGURE 9 Lace trimming with a depiction of 'I was born in a rose bush', 1902



to the workshop in Halas slowly declined. The first artistically and technically prominent period of the 'Lace From Halas' in the style of the Secession come to an end with his departure.

## Endnotes

- 1 Anon. *Style 1900. A Great Experiment of Modernism in the Applied Arts*. Museum of Applied Arts, Budapest 1996. Cat. 1.59
- 2 A.S. Levetus. State Schools for Lace-Making in Austria. *The Studio*. (October 1905) 24.
- 3 A.S. Levetus, op cit., p.20.
- 4 A.S. Levetus. op cit., p.25.
- 5 The lace cuffs, which poetically reinterpret the Renaissance flower bush, along with the collar of the same set, can be found in the collection of the Museum of Applied Art in Budapest.
- 6 *Magyar Iparművészet* (1906): 232.
- 7 Extracts from an autobiography, dating in all probability to the final year of his life, which he sent to Károly Lyka, an outstanding Hungarian art historian of the age who knew him well and had great respect for him. (Database of the Hungarian Academy of Sciences, MDK-C-I-17/261. 1-9) 'I was born on the 12<sup>th</sup> of March in the year 1861 in Alsó Jára, in the county of Torda aranyos, where my father was an official at a mine. I went to middle school in Nagyenyed, Marosvásárhely and Székelyudvarhely. The drawing teachers Károly Nagy of Nagyenyed and Gyula Fankovich of Székelyudvarhely were a strong influence upon me in these years. I had a great love for folk art, and dealt with it a lot even at that time. My father intended me to take up the profession of an engineer, and in line with this I enrolled at the technical university in Budapest, but I did not like the profession, and I left it without the knowledge or permission of my father, to join the art-teacher's school on Andrassy Street. When my father came to know of this, in his anger he cut off all support for a whole year. I lived from hand to mouth, as best I could, giving lessons, taking my books to the antiquaries, just as any poor kid would. My father was not appeased until I won the state scholarship of 600 crowns. I think of the times I spent at the teacher training school with eternal gratitude and delight. My teachers were: Gusztáv Keleti, Bertalan Székely, Károly Lotz, Frigyes Schulek, János Greguss, Adolf Huszár, Lajos Rauscher and Szilárd Várdai. I secured a diploma at the teacher training school in 1885. I had hardly arrived home to my parents when I received the letter from Károly Szász, ... Bishop of a region by the Danube banks, inviting me to join as teacher of art at the High-School of the Reformed church in Kiskunhalas.'
- 8 1903. Light green, red, grey, orange, yellow and black silk yarn. Budapest, Museum of Applied Arts, inv. no. 13428
- 9 1906. Pale yellow, greenish blue and red silk and raw coloured flax yarn. Budapest, Museum of Applied Arts, inv. no. 54.2962.1.
- 10 1903. Orange-red, yellow, green, greyish blue, claret silk and raw coloured flax yarn. Budapest, Museum of Applied Arts, inv. no. 18135
- 11 Emőke László, Emese Pásztor, and Aurél Szakál: *Halasi csipke - Halas Lace - Halaser Spitze*. Kiskunhalas, 1996. pp.9-12.
- 12 1903. Pale red, grey, greenish grey and yellow and raw coloured flax yarn. Budapest, Museum of Applied Arts, inv. no. 10600
- 13 1903. Two types of light green silk and raw coloured flax yarn. Budapest, Museum of Applied Arts, inv. no. 13422
- 14 1903. Light green, yellow, and brick coloured silk and raw coloured flax yarn. Budapest, Museum of Applied Arts, inv. no. 10587
- 15 c. 1905. Sewn from bone-coloured silk, and white and raw coloured flax yarn. Budapest, Museum of Applied Arts, inv. no. 11994
- 16 1902. Pale red, green and yellow silk and raw coloured flax yarn. Budapest, Museum of Applied Arts, inv. no. 10593
- 17 1902. Pale green, red and yellow silk and raw coloured flax yarn. Budapest, Museum of Applied Arts, inv. no. 10597
- 18 László, Pásztor and Szakál, op cit., Cat. 11. This work is unique in the history of Hungarian lace and Dekáni's work. Apparently inspired by the painted fans of the eighteenth century, he depicts a village scene on the fan. A Hungarian village is portrayed in the background, with shepherds in the corners, and a wedding procession makes its way across the sticks of the fan.
- 19 According to reports published in newspapers of the day, a major collection was bought on behalf of the St Louis Museum (*Az Újság*, 25<sup>th</sup> December 1903). It is up to future research to uncover these tracks.
- 20 Studio Talk. *The Studio* 1908. Sept. p.283-285; A.S. Levetus. The revival of Lace-Making in Hungary. *The Studio* 1910. Vol. 51. No.211. p.30-35.

This travelling tapestry is a valuable item in the textile collections of the Hungarian National Museum.<sup>1</sup> It is known to have been in the possession of Ferenc Rákóczi.

[ GYÖRK MÁTÉFY ]

## The conservation of the painted cloth travelling ‘tapestry’ of Ferenc Rákóczi II\*

**T**he travelling tapestry, which was made to imitate the texture of tapestry weaving, is of calico painted in tempera with evidence of Italian influence in its colours, used to hang in Rákóczi’s hunting castle in Zboró, together with six other hangings. Unfortunately some pieces were taken to Vienna by an art dealer, where, in a similar way to other Hungarian treasures, they disappeared. One of them was bought in 1930 by the artist Viktor Olgyay, who had seen all of the pieces in situ in Zboró 30 years before. This object, being the travelling ‘tapestry’ of Ferenc Rákóczi II, is an extremely interesting relic of cultural history. There is another painted ‘tapestry’ in Transylvania and six other painted tapestries in the Batthyány Castle in Körmend, which are the last relics of this little known Hungarian craft, which had been shaped by the Hungarian way of life.<sup>2</sup>

As can be read in contemporary written sources, in Europe, and in Northern Hungary and Transylvania as well, the walls of the suites of rooms in royal and aristocratic castles, palaces and mansions were made more comfortable and pleasant with valuable oriental carpets and wall hangings made from wool and silk yarns, decorated with metal threads (gold

and silver), usually depicting mythical, historical and biblical scenes. As said at the time, their homes were dressed up. Dressing up houses was quite widespread in the fourteenth century in Hungary, and even during the reign of King Matthias (1440-1490). The wall hangings and carpets were referred to as ‘house dressings’ in the will of Gábor Bethlen, prince of Transylvania (1580-1629). The precious hangings were bought in Italy (Venice) and in the Low Countries. There were 12 large-size Flemish tapestries among the belongings of Catherine of Brandenburg, the wife of Gábor Bethlen. In 1631 she reclaimed from György Rákóczi a series of wall hangings which had been left in the castle of Munkács; they depicted the *History of Alexander the Great* and were worth 15,000 tallérs in her estimation.

The felt hangings were written, that is painted, decorated with figures and the walls in the ceremonial hall of György Thurzó’s house and his wife’s house were covered with hangings like these. Whenever he set off on a journey he took 14 pieces of the painted calico ‘tapestries’. If the hanging was made of linen, it was also painted, so that it would not be so monotonous. In the guestroom of Baronesses Viczay there was one



FIGURE 1  
Photograph, c.  
1930, of travelling  
tapestry (after Pál  
Voit 1943)



like that in 1681; four years later János Haller bought a similar one in Vienna and paid half a *tallér an ell* for painting it.<sup>3</sup>

The painters, sign-writers, and drapery painters, who painted these linen or felt tapestry wall hangings, which were called travelling or Viennese tapestries, started arriving in Hungary in the seventeenth century. 'It is known that our seventeenth-century painters, apart from painting frescos and panel pictures, made coats-of-arms, flags and tapestries as the members of the picture-writers' guild in Kolozsvár'.<sup>4</sup> The popularity of picture-writing and painted hangings is also mentioned in several contemporary, fragmentary written sources. In Hungary and Transylvania the first picture-writing guilds were organized in the seventeenth and eighteenth centuries. Several important guilds were active in Rákóczi's time in Kolozsvár, Nagyszeben, Kassa and Lőcse. The tapestry restored by the author could have been made in any of these workshops, although, as their widespread name indicates, such textiles could have been brought to Hungary in large numbers from Vienna and probably from Nuremberg.

Written sources often mentioned the Viennese hangings alongside the Italian silk and velvet 'tapestries' and the leather 'tapestries' from the Low Countries and Flanders. The 'tapestry' in Mihály Apafi's court in Ebesfalva was probably a painted imitation of the one with hunting scenes, probably from Flanders. The travelling 'tapestry' of Ferenc Rákóczi II, which can be seen in the collections of the Hungarian National Gallery at the moment, is probably from the prince's castle in Zboró; it is a painted calico imitating the technique of tapestry weaving.<sup>5</sup>

The above-mentioned tapestry had the following label in the exhibition: 'Hungarian or Polish, from c. 1700. Alexander the Great and Diogenes. A piece from the series of travelling' tapestry' of Ferenc Rákóczi II'. (It differs in size from the object in the Hungarian National Museum). Apart from the woven or gilt tapestries painted on calico or felt, there were other hangings made of textiles, embroidered leather and appliqué wall hangings.

In a similar way to the sign-writers, the wall hangings can also be found in relevant entries of the

FIGURE 2 Left border, showing early repairs (detail)

FIGURE 3 Left border, early repair stitching

FIGURE 4 The tapestry during conservation

FIGURE 5 A frayed part of the tapestry being applied to the new support fabric

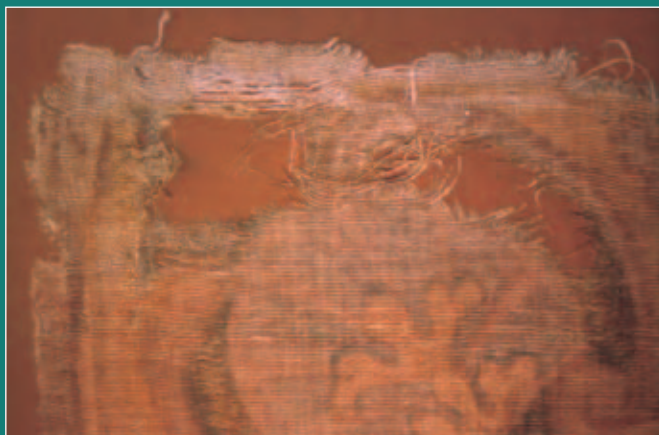
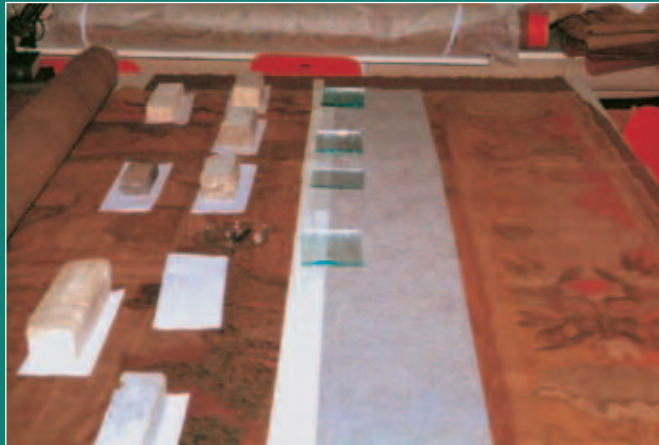
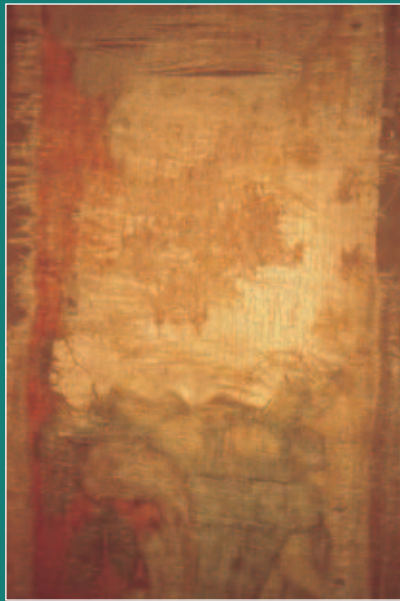

Beczi'(Viennese) or 'Iratos, Vászonra írott kárpit', which means 'painted, tapestry painted on calico'. Examples include:

'1489. Two pieces of fine Viennese tapestry and five ragged ones ...'

'1596. Ten cubits of tapestry ... 10 f. And eight cubits of Viennese tapestry ... 44 f, there are six Viennese tapestries ...'

'1627. Three worn-out Viennese tapestries ...'

'1629. A fine hanging ... Three worn-out Viennese hangings ...'

'1637/1639. There is a Viennese hanging decorated with horses by the first window. Then at the doorway behind the stove there is another green Viennese hanging. Between the door and the second window there is a red felt Viennese hanging decorated with kings in two pieces ...'

'1651. There are three Viennese hangings, two of them with horses, one with columns ...'

The woven wall hangings made in western European workshops were so valuable that the expensive textiles were not carried anywhere, not even by the great princes, to avoid damage during the journeys. For this purpose cheaper fabrics (usually calico or felt) were painted as replicas of pictorial woven tapestry although they were only fair imitations of the original. They were excellent however for transforming temporary lodgings or tents into a luxurious palace when, for example, Ferenc Rákóczi II was travelling, living in tents or staying somewhere.<sup>7</sup>

*Transylvanian Hungarian Etymological Dictionary* (Erdélyi Magyar Szótörténeti Tár)<sup>6</sup> relating to the sixteenth-eighteenth centuries, when the 'tapestry' restored by the author was probably made. This type of 'tapestry' is referred to as 'Bécsi/Bechy, Bechi,

The conservation of the travelling tapestry was problematic because the base material had to be treated according to the rules of textile conservation

FIGURE 6 Detail of the tapestry showing conservation stitching

FIGURE 7 The tapestry in the permanent historical exhibition at the Hungarian National Museum



while the painted surface had to be treated like the pictures painted on cloth. This problem is similar to those encountered during the conservation of pictures painted on cloth (landscapes, gardens, interiors), which were used until recently as backgrounds for photography; the treatment of such cloths is even more complicated because these items were painted with water-soluble colours; they therefore have to be treated with special methods during cleaning.

The technical data of the travelling tapestry is as follows: Size: 456x329 cm. Threads: warp: flax, weft: flax. Twist of threads: warp: Z, weft: Z<sub>4</sub>S. Basic texture: warp-faced rep. Number of threads: in the warp: 66/10 cm, in the weft: 44/10 cm. Due to earlier poor storage conditions, the tapestry was rather soiled, dust-covered, dry and brittle, and due to inappropriate packing and storage it was broken and wrinkled when it was taken to the National Museum. There is an ambiguous word - Botek or



Batek - written in cursive handwriting in the bottom right corner of the reverse.

The wet-cleaning treatment of the travelling tapestry, necessary to soften the textile and smooth out the wrinkles, was problematic because the paint medium, probably gum arabic, was soluble in water.

After the mechanical cleaning the tapestry was placed on blotting paper and the surface slightly dampened by ultrasonic humidification. Care was taken not to dissolve the binding medium of the paint. Then the fibres of the textile were arranged in their original position.

The tapestry was supported with a cotton fabric which had been dyed to a matching colour. The supporting fabric was stitched to the tapestry in 25 x 3 cm sections. After that, the weak, deteriorated parts of the tapestry were fixed with couching stitches. The missing parts were not replaced with new threads, but were only supported. The blue trimming of the tapestry, which was not original and had been stitched to the object with a sewing-machine, were removed. A new trimming was made from the fabric of the supporting material, was folded back in a 4 cm width. For hanging, velcro-tape (10 cm wide, 110 cm long) was stitched to the upper edge and to the upper part of the left and right sides.

The large size of the tapestry caused many problems during the work, so the parts which were not being worked upon were temporarily rolled into a 460 cm long and 13 cm diameter cylinder, covered with acid free fabric.

The tapestry was conserved for the exhibition 'The history of Hungary between 1000 and 1990' which was opened in 1996 in the Hungarian National Museum.

## Endnotes

- <sup>1</sup> Hungarian National Museum Inventory number: T 1989.16
- <sup>2</sup> Voit, Pál: *Régi otthonok* [Old homes], Budapest, 1943: 144-146. The photograph on p.145 shows one item from the collection of Viktor Olgyay's widow.
- <sup>3</sup> Radvánszky, Béla: *Magyar családélet és háztartás a XVI. és XVII. században* [Hungarian family life and household in the 16<sup>th</sup> and 17<sup>th</sup> centuries] Budapest, 1879:15-16, 24-25.
- <sup>4</sup> Voit: op.cit. p.144.
- <sup>5</sup> Written by Erzsébet Vadászi in the Radvánszky book, published in a re-print, 1986.
- <sup>6</sup> *Erdélyi Magyar szótörténeti Tár* [Transylvanian Hungarian Etymological Dictionary] ed. Attila Szabó T.) Budapest, 1993. Vol. 6. p.211-212., 399.
- <sup>7</sup> I have to mention a third painted travelling tapestry, which I saw in private ownership in the 1990s in Budapest. The base material had a finer texture than the hanging in the Hungarian National Museum.

---

\* Ferenc Rákóczi II. (born in Borsi, 1676; died in 1735 at Rodostó, known today as Tekirdad, Turkey) was the reigning prince of Transylvania between 1704 and 1711. Due to the difficult financial and political situation of the country he sought help from Louis XIV, King of France, who agreed to support him in the revolt against the Emperor of Austria. The plot was detected by the Austrians, so Rákóczi fled to Poland, whence he set off with his troops and they succeeded in reaching the river Danube. The parliament declared the Habsburg Dynasty dethroned in 1707 and was determined to continue the fight for independence. The Emperor's troops outnumbered Rákóczi's fighters, who were forced to slowly retreat. In the autumn of 1711 Rákóczi left the country and lived in the French royal court from 1713; after 1718 he went into exile in Turkey where he lived in the coastal town of Rodostó until his death in 1735.

The title of this paper uses the word 'restoration', but what does it mean? In Europe the job title 'restorer' means the same as the job title 'conservator' in the UK and America. In both cases these are the professionals who 'conserve' antiques, antiquities, works of art and historic sites and structures. In English the origin of *this* meaning of the words conservator/conservation is very recent, probably having been 'invented' not long before the founding of the International Institute for Conservation of Historic and Artistic Works in 1950. It has gradually become preferred to the title 'restorer' since the introduction of the 'conservation' grade in the UK National Museums in 1964.

[ ANDREW ODDY ]

# The philosophy of restoration:

NEW FOR OLD?\*

**N**evertheless, as late as 1995 *The Concise Oxford Dictionary of Current English* was apparently unaware of the new use of the word,<sup>1</sup> as it defines 'conservation' as 'preservation, esp[ecially] of the natural environment' and a 'conservationist' as 'a supporter or advocate of environmental conservation'.<sup>2</sup> Conservationist was first used in 1870.<sup>3</sup>

So, what is meant by 'conservation'? The process has four stages:

- cleaning
- stabilization
- repair
- restoration

Not all four stages will be necessary for all objects or historic structures.

A typical example would be a broken pottery vessel excavated in the Middle East where soil often has a high concentration of soluble salts, usually chlorides.

- Stage 1 is the careful removal of soil by mechanical methods, washing, or, infrequently, the use of chemicals.
- Stage 2 consists of soaking in changes of distilled water to remove the soluble salts; without this stage the pot will be unstable and is likely to deteriorate if subjected to variations in relative humidity.
- Stage 3 is the re-assembly of the sherds by sticking with an appropriate adhesive; at the British Museum the preferred adhesive is cellulose nitrate.
- Stage 4 is the filling of *lacunae* with plaster of Paris or some other filler.

\* This paper was read to a colloquium held at the Humboldt University in Berlin on 3 and 4 March 1997. It has not been published, but as it represents a stage in the evolution of my thoughts on the philosophy of conservation, it is offered as a tribute to the memory of Ágnes Timár who was deeply interested in the theory of conservation.

To ‘conservators’ working in museums before about 1960, the second stage was often ignored as the potential instability of many objects was not recognized. Of course, the instability of excavated metalwork *was* usually recognized as the signs of continuing deterioration were so obvious – flaking and ‘weeping’ of iron or bright green powdery excrescences of bronze disease on copper alloys for instance. But salt problems in ceramic and stone objects often took months, or even years, to manifest themselves, by which time the objects were ‘safely’ in the museum store where the chance of their being regularly inspected was remote.

So if stabilization was often ignored, were stages 1, 3 and 4 carried out before *ca.* 1960 as they would be today? The answer, of course, is ‘no’.

Cleaning, to a conservator of today, means removing material which is not part of the original object while looking out for evidence for the contemporary ‘life’ of the object. Thus, soot on a cooking vessel would have been cleaned off by a previous generation of conservators, but not, it is to be hoped, by the conservators of today. Vessels should be inspected inside for any evidence of the food which was processed in them, and tools may retain traces of the materials on which they were used – and this also includes the possibility of finding traces of blood on weapons. Even clothing may retain evidence of the occupation of the wearer and textiles may have stains relating to their use.

Traces of paint are frequently found on objects nowadays when many conservators have access to a

good binocular microscope, and a few of them also have access to an analytical laboratory which may even be able to identify the actual pigment and the binder. In fact, it has long been known that much stone sculpture was painted, but it is now emerging from the examination of well-preserved material from waterlogged sites that metalwork was also painted,<sup>4</sup> although the extent of this practice in the past is far from certain!

The problem with metal objects is that corrosion has usually destroyed the original surface, although the *position* of the surface may survive within the corrosion layer. A good example is a bronze altar from South Arabia, now in the British Museum. When it was acquired it was covered in very thick corrosion products (Fig.1), but mechanical cleaning with the help of a hand-held electric engraving tool revealed the original surface (Fig.2). That original surfaces really do exist deep in the corrosion can be demonstrated by examination of a cross-section of a fragment of a corroded Assyrian bronze bowl from Nimrud (Fig.3), also now in the British Museum. The metal is almost completely corroded away, apart from traces in the centre of the section. The bowl now consists almost entirely of red cuprous oxide and green corrosion products of copper (most probably basic cupric carbonate) but within the cross-section two parallel ‘lines’ are clearly visible. These represent the original surfaces (top and bottom) of the thin bronze bowl. Chemically, however, both sides of the original surface now consist of cuprous oxide.



FIGURE 1 Bronze altar from South Arabia before mechanical cleaning of the surface



FIGURE 2 Bronze altar from South Arabia after mechanical cleaning of the corrosion layer down to the original surface.

This is a perfect demonstration of why *chemical* cleaning of ancient bronzes has been largely abandoned as chemicals cannot distinguish between the cuprite on top of the original surface and the cuprite below it. The result of chemical stripping, unless very carefully controlled, is that it removes all the corrosion products and leaves a much pitted metal surface.

But even the corrosion product now on top of the original surface is derived from the original object itself. The same is true of weathering layers on marble and glass. So if these alteration products<sup>5</sup> were (albeit in a very different form) part of the original object, should they ever be removed?

Before about 1970, the question of whether or not to remove alteration products was hardly ever asked. Conservation was seen as an attempt to travel back in time and present the object as it appeared before it was lost, broken or abandoned. Thus the stripping of metals was routine and has resulted in the wholesale ‘destruction’ of iron objects in particular, but of other metals as well. What happened was that corrosion products were removed without the depth and extent of the corrosion having been estimated beforehand. The result was that the outlines of objects changed – swords, for instance, ended up with a ‘ragged’ edge to the blade or with a ‘lacy’ appearance because the corrosion had penetrated completely through the

metal in some areas. Another result of stripping is that the extent of ancient polychromy on metals was never even envisaged as any remaining traces of colour were destroyed forever by the ‘stripping’ process.

What is surprising today is that it took so long to recognize the folly of chemical or electrolytic stripping of metals<sup>6</sup> – a *mere* 60 years or so from the first publication of some of the commonly used methods by Friedrich Rathgen at the very end of the nineteenth century.<sup>7</sup>

But what today is regarded as excessive cleaning was not, in the past, confined to metals. The so-called ‘orange patina’ on parts of the Elgin Marbles<sup>8</sup> was partially removed in the 1930s, and was a source of controversy at the time because of disagreements about its origin and because of the abrasive methods used to remove it.<sup>9</sup> But this cleaning, was carried out in the spirit of the times when the philosophy of many restorers was, as far as possible, to make the objects look like they did when first made. What today would be regarded as excessive cleaning was the ‘norm’ at that time, not only for antiquities, but also for works of art on paper as well as for easel paintings. Thus, black-and-white prints were routinely bleached to remove dirt stains and ‘foxing’, but the by-product was a ‘staring white’ paper which was undoubtedly ‘brighter’ in many cases than when

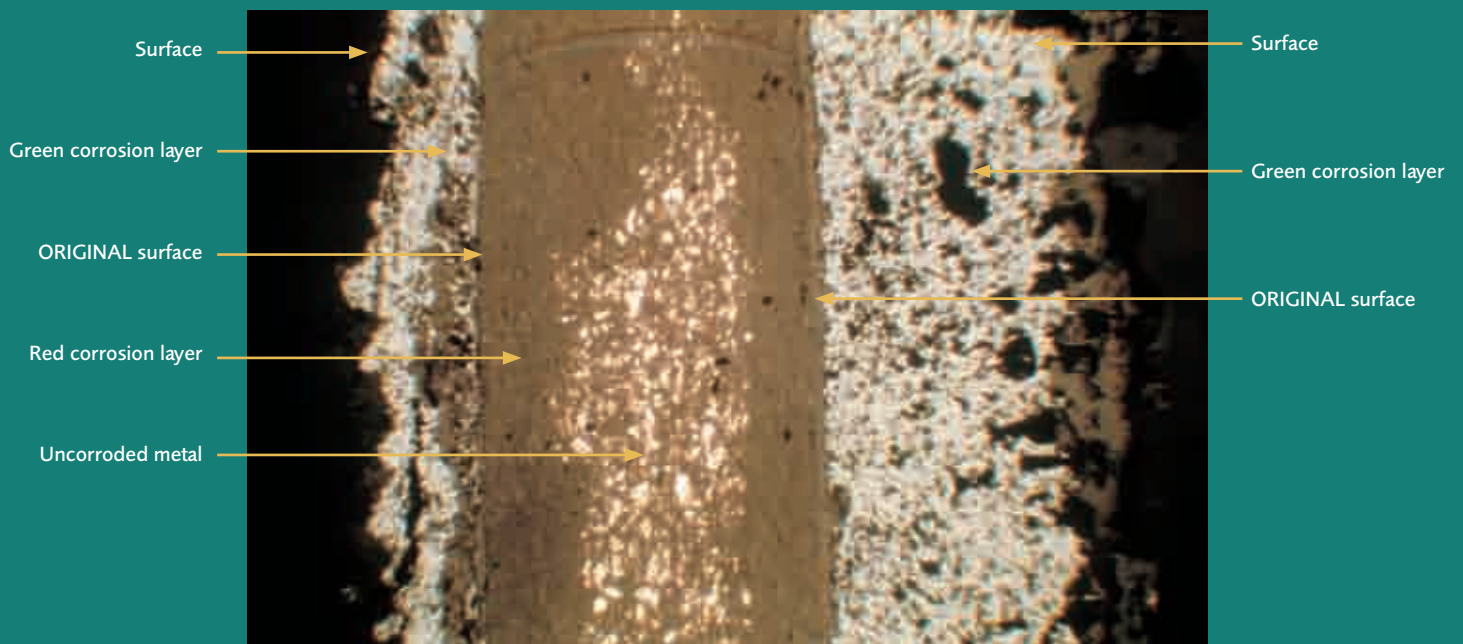

FIGURE 3 Metallographic cross-section of a fragment of a corroded Assyrian bowl to show, in particular, the original surfaces

first used by the artist for the printing. Similarly, many metal objects had all their corrosion products chemically stripped from the surface so that they lost their original outline..

Easel paintings are a special case, and the debate about cleaning in the National Gallery in London has now raged for one and a half centuries.<sup>10</sup> The recent cleaning of the Michelangelo frescoes in the Sistine Chapel in the Vatican has again focussed debate on the original appearance of works of art and on our attitudes to what the objects *should* look like now.<sup>11</sup> Hence the ‘new for old’ subtitle of this paper.

There was, however, one category of object which was, on the whole, protected from excessive cleaning regimes – those with a surface patina which was regarded as aesthetically pleasing. The first recorded use of the term *patina* in English is in 1748 to describe the green alteration product on bronzes, which was smooth and attractive.<sup>12</sup> The word was borrowed from Italian. The use of the word ‘patina’ was gradually extended to other materials, including marble statuary and wooden furniture, but whereas the nature of the natural patina on bronze is very clear – the result of the reaction of the metal with water and (usually) carbon dioxide in the atmosphere to generate a layer of basic copper carbonate (the green layer) – it is less easily definable on marble and wood.

According to Plenderleith,<sup>13</sup> patina on marble is the result of the dissolution and re-deposition of the marble (calcium carbonate) to produce a translucent layer, which may be coloured by impurities in the rainwater or ground water. Today most conservators would not dream of removing this type of patina on marble, but to the pre-war *formatori*<sup>14</sup> it was just another disfiguring surface deposit which was seen as no different from layers of ingrained dirt compacted with ‘modern’ wax polish. The latter have no place on the surface of marble sculpture, either in the 1930s or today.

When the Elgin marbles were redisplayed in the Duveen Galleries of the British Museum in the 1960s, they were again cleaned, but this time only using a poultice made of Sepiolite (a naturally occurring magnesium silicate) and distilled water.<sup>15</sup> This removed so much dirt that had settled on the stone from the notorious London smog of the previous 30 years that, after cleaning, the sculptures appeared *light* against the darker background of the off-white gallery wall, whereas, before cleaning, they had appeared *darker* than the surrounding building (Fig.4).

Cleaning, even though no chemicals were used, did have an undesirable side-effect. The cleaned marble had a ‘milky’ or ‘hazy’ appearance because, on a microscopic scale, the removal of dirt had

opened up the surface, which was no longer smooth. Before cleaning, the irregularities of the stone surface were full of dirt and the sculptures reflected light differently. This effect was largely mitigated by applying a 10% solution of polyethylene glycol in distilled water – a wax-like material which remains soluble and so is easily removed.

As far as furniture is concerned, *patina* is a combination of colour changes in the wood brought about by the effect of light, deliberately applied surface finishes, and the build-up of wax polish. Although this *patina* is not an alteration product of the wood, it should usually be preserved, although it is difficult to know what the original craftsmen intended the piece to look like in many cases.

This discussion of cleaning has been rather wide ranging and it has been shown that attitudes to cleaning have changed radically in the last 40 years. But the question put earlier about whether it can ever be right to remove metal alteration products from objects when the corrosion products are derived from the objects themselves has still not been answered. In fact, there is no doubt that this is perfectly acceptable and the museums of the world are full of wonderful ancient works of art made of metal – usually bronze – which have been skilfully liberated by hand from a cocoon of unsightly alteration product.

As far as the conservation of potentially ‘active’ or ‘unstable’ materials is concerned, stabilization has now become an automatic sequel to the cleaning process following the introduction of methods for treating potential problems like ‘bronze disease’ and ‘weeping iron’. The same principle is true for fragmentary textiles which will be supported on an inert backing textile, or for furniture which will have loose joints re-glued. But what of the third and fourth stages of the conservation process – repair and restoration?

The science of adhesion and adhesives has increased out of all recognition since the Second World War, but the universally accepted standard is still to match the strength of the adhesive to that of the material being repaired. Thus, although an epoxy resin adhesive is appropriate for the re-assembly of porcelain and glass, it is inappropriate for sticking together prehistoric pottery because it is far too strong. Interestingly, the earliest of the modern synthetic materials, cellulose nitrate, first used commercially as a plastic in 1855 and recommended by Rathgen in the 1890s as an adhesive for conservation, is still the best material for repairing and re-assembling many different types of antiquity,<sup>16</sup> in spite of recent attempts to discredit it.<sup>17</sup>

Thus the philosophy of repair has *not* changed over the years. The aim was, and still is, to assemble the existing fragments of a broken object using the



most appropriate adhesive to minimize the impact of the joins on the eye. What has changed is the range of adhesives. For conservators before the middle of the 20th century, it was a question of natural gums or resins, shellac, animal or fish glue, or cellulose nitrate, and the use of the last of these gradually became more and more popular. When a gap-filling adhesive was required, one of the above materials would be mixed with sawdust, powdered marble, or any 'inert' filler related to the materials of which the object was made. Sometimes plaster of Paris would be used, or even mixtures of casein and lime. Today, of course, gap-filling is done by adding inert fillers to an appropriate synthetic resin, and, although powdered marble may be used, it is more common to use glass or resin micro-balloons. Plaster of Paris, however, also remains a firm favourite, although the totally synthetic alternatives are preferable for many materials.

If the philosophy of repair has not changed, that of restoration has. In the past, restoration, reflected the approach to cleaning. Thus, what is now seen as excessive cleaning was felt to be complemented by complete restoration, so that objects looked like they did when first made. More recently, however, a more thoughtful approach to cleaning has gone hand in hand with gap-filling which is clearly visible on close

inspection of the object, or even no gap-filling at all on some objects, particularly ancient sculpture.

The change in philosophy has been gradual, so that in the British Museum in the late 1960s, the Department of Greek and Roman Antiquities was removing nineteenth and early twentieth-century restorations from their sculptures, while the Department of Egyptian Antiquities was still carrying out almost invisible restoration. In the 1990s, the Greek and Roman department is again interested in having 'invisible' restoration in some cases.

For most materials, the basic rule of restoration is that any agreed (that is 'agreed' between the curator and conservator) restoration should be carried out in a different material from the original. Thus ceramics conservators usually gap-fill using plaster of Paris and metals conservators often use a polyester paste. However, conservators of organic materials may use the *same* material, particularly when restoring furniture or works of art on paper. In these cases, the normal process of documenting the conservation assumes an even greater importance as the added materials must be clearly identifiable in the conservation record.

Few conservators would disagree about the meaning of restoration; it is gap-filling but with a multitude of different approaches to the finishing

FIGURE 4

Two pediment figures from the Parthenon in Athens. The left-hand figure was cleaned by the Sepiolite method in the late 1960s. The right-hand figure has not been cleaned for thirty years. Since the 1960s, the Elgin Marbles have been exhibited in an air conditioned gallery and have not needed to be cleaned



of the fill. But what is gap-filling trying to achieve? Invisible gap filling is (presumably) trying to recreate the object at some stage in its life. But do the curators and conservators ever consciously consider *what* stage? 'Perfect' restoration of an otherwise 'perfect' object generates an object which looks like the day it was made. Although the appearance deceives the viewer, it can be justified (if conservation records have been kept) on the grounds that the object once looked like that. Most museums, however, prefer a restoration that goes unnoticed by the casual visitor who strolls past an exhibition, but is obvious on close examination.<sup>18</sup> But can this be justified? The object *never* looked like this in its lifetime.

Should the aim of restoration rather be to portray reality, rather than a creation of today? If this is so the modern approach to restoration is quite wrong and we should be choosing one moment in the life of an object and trying to recreate that – the day it was made – one day during its 'life' – the day it was broken, lost or abandoned, or even **the day it was found**. And if the final act in the life of a pot was its breaking on the floor, have we any 'right' to repair and restore it at all?

The conservation process has changed radically in the last two generations from (usually) maximum intervention to (more often) minimum intervention. For many types of object, the emphasis is on stabilization rather than on complete cleaning and total restoration, and while the process of stabilization may involve, for instance, the removal of soluble salts from porous stone or pottery, it may involve merely keeping (displaying or storing) the object in a controlled environment in which the soluble salts will not be a problem.

Thus, in the last 30 years, 'passive' conservation has assumed major importance as another way of 'conserving' objects. What the managers of conservation have to do now is to assess the relative costs of the two approaches to the preservation of objects: a one-off treatment (assuming that the stabilization stage is always totally successful), or ongoing care (the permanent provision of controlled environments). But these relative costs are not always easy to calculate.

An example of this dilemma is provided by the three recent attempts to conserve the Riace bronzes, two Greek bronze statues of gods/athletes/heroes recovered from the sea off Riace Marina on the Calabrian coast of the Ionian Sea in August 1972.<sup>19</sup> Since the bronzes were found they have been conserved three times: first in the museum at Reggio di Calabria immediately following their discovery; second in the laboratories of the *Soprintendenza Archeologica della Toscana* in Florence between

1975 and 1979; and third at the *Istituto Centrale per il Restauro* in Rome between 1992 and 1995. All three treatments have struggled with the fact that when the bronzes were found they still contained their original iron armature and clay casting-core, all of which was thoroughly impregnated with chloride from the sea. Inevitably, the bronze was unstable, and so at the third restoration a decision was made to remove the casting core. This was done in Rome and the process recorded as thoroughly as possible under the difficult circumstances. The result, however, is a pair of bronze statues now bereft of the original core, but which are reported *still not to be stable* and need to be exhibited in a controlled environment.<sup>20</sup> As so few statues from the ancient world still retain their casting core *in situ*, it must be asked whether the statues could not have been exhibited in a controlled environment *without* removing the cores. If future generations do not agree with the interpretation put on the method of casting, we have only the fragments of core in the storeroom and the video footage of the investigation for documenting any other theory.

It is, of course, easy to be wise with hindsight, but a partial excavation of one statue, with the rest of the core left for future generations to excavate, might have been a better course of action. It would certainly have been much cheaper than three expensive interventions, and the ongoing costs of exhibition in a controlled environment would be the same.

Some of these thoughts will be seen as controversial, or even heretical. But the emerging profession of conservation has been too slow to question its methods and techniques. The result has been distrust of conservators by some curators and positive opposition by others. With the start of the new millennium it is time to show that we are aware of the long-term implications of our profession for the cultural heritage.

## Endnotes

- <sup>1</sup> *The Concise Oxford Dictionary of Current English* (9th ed.), Oxford, 1995.
- <sup>2</sup> It is interesting to note that in the USA, *Webster's Third New International Dictionary of the English Language* is more up to date. It defines a 'conservator' as 'one that preserves from injury or violation: protector, preserver (a fine art conservator)'; a 'conservationist' as 'one that advocates conservation especially of natural resources'; and 'conservation' as 'the repair and preservation of works of art'.
- <sup>3</sup> Little, W. et al., *The Shorter Oxford Dictionary*, 3rd ed., Oxford, 1973. In the UK today, the media frequently use the word 'conservationist' when 'conservator' is meant.
- <sup>4</sup> Private communication from Suzanne Keene
- <sup>5</sup> 'Alteration product', rather than 'corrosion product', is the preferred term to indicate a weathered surface.

- 6 Jedrzejewska, H. Some new experiments in the conservation of ancient bronzes, in G Thomson (ed.), *Recent Advances in Conservation*, London, 1963, pp.135-139; Jedrzejewska, H. The conservation of ancient bronzes, *Studies in Conservation* 9(1) (1964)23-31.
- 7 Rathgen, F. *The Preservation of Antiquities: A handbook for Curators*, Cambridge, 1905. First published in Berlin in German in 1898.
- 8 The 'Elgin Marbles' is the name by which the sculptures from the Parthenon in Athens, now in The British Museum, are known.
- 9 There is an extensive recent bibliography on this episode. St Clair, W. The Elgin Marbles: Questions of Stewardship and Accountability, *International Journal of Cultural Property* 8 (2) (1999) 391-521; Jenkins, I. The Elgin Marbles: Questions of Accuracy and Reliability, *International Journal of Cultural Property* 10 (1) (2001) 55-69; Jenkins, I. 'Sir, They are scrubbing the Elgin Marbles!' Some controversial cleanings of the Parthenon Sculptures, *Minerva* 10 (6) (1999) 43-45; Oddy, A. The conservation of marble sculptures in the British Museum before 1975, *Studies in Conservation* 47 (3) (2002) 145-154; Jenkins, I. (ed.), *Cleaning and Controversy: The Parthenon Sculptures 1811-1939*, British Museum Occasional Paper no.146, London, 2001.
- 10 The literature on the cleaning of paintings at the National Gallery in London is very extensive. There is no recent, balanced account but see: Beck, J. *Art Restoration: The Culture, the Business and the Scandal*, London, 1993, ch. 5; Hendy, P. *An Exhibition of Cleaned Pictures*, National Gallery, London, 1947.
- 11 Various authors, *Michelangelo e la Sistina. La tecnica, il restauro, il mito*, Rome, 1990; Mancinelli, F. Michelangelo's Frescoes in the Sistine Chapel, in Oddy, A (ed.), *The Art of the Conservator*, London, 1992, pp. 89-107; Mancinelli, F. The Frescoes of Michelangelo on the Vault of the Sistine Chapel: Conservation Methodology, Problems and Results, and Colalucci, G. The Frescoes of Michelangelo on the Vault of the Sistine Chapel: Original Technique and Conservation, both in Cather, S. *The Conservation of Wall Paintings: Proceedings of a Symposium ...*, The J Paul Getty Trust, Los Angeles, 1991: 57-66 and 67-76; Beck, J. *Art Restoration: The Culture, the Business and the Scandal*, London, 1993, chs. 3 and 4. There are many other articles in journals, magazines and newspapers debating this cleaning episode.
- 12 Little, W. et al., *The Shorter Oxford Dictionary*, 3<sup>rd</sup> ed., Oxford, 1973.
- 13 Plenderleith, H. J. *The Conservation of Antiquities and Works of Art*, Oxford, 1956: 314.
- 14 *Formatori*, according to Harold Plenderleith in an interview with Andrew Oddy in 1987, is the name by which the craftsmen who conserved objects before about 1940 were known.
- 15 Oddy, A. op. cit., *Studies in Conservation*.
- 16 Shashoua, Y, Bradley, S. M. and Daniels, V. D. Degradation of cellulose nitrate adhesive, *Studies in Conservation* 37 (2) (1992) 113-119.
- 17 Koob, S. P. The instability of cellulose nitrate adhesives, *The Conservator* 6 (1982) 31-34.
- 18 Oddy, A. Compensation for loss – why do we do it?, *Abbey Newsletter* 21 (2) (July 1997) 22-24.
- 19 See the special number of the *Bolletino d'Arte*, devoted to the Riace Bronzes, which was published in 1984 (special series 3, vol.1).
- 20 From a paper given by M. Bartolini, B. Colombo, M. Marabelli and A. Marano at a conference (as yet unpublished) in Rome in November 1995.

A rich variety of 'linens' made from cotton or linen fibres can be found mentioned in Transylvanian sources and are documented in Hungarian in the inventories of aristocrats and the nobility, listed in marriage settlements and in the stock records and limitations of inherited estates. Both fine and somewhat rougher cotton or linen fabrics were used to prepare the sort of textile articles collectively identified at the time as 'white linen', and which comprised: noble men's and women's shirts worn as underwear and as over-garments, and embroidered handkerchiefs; aprons, veils, headwear, bonnets and protective masks, etc. that were the accessories of women's clothing at the time; table-cloths, napkins, and handkerchiefs used as table linen, as well as bedding, which included upper and under sheets, pillow- and bolster-slips, and quilt covers; and finally, liturgical cloth, with embroidery on a cotton base fabric, antependia, chalice-covers, altar-cloths, etc.<sup>1</sup>

EMESE PÁSZTOR

## Bulya vászon:

A TYPE OF LOOSELY WOVEN CLOTH

A short extract from the inventory of the personal effects left as a legacy by Mihályné Bécsi in Rimaszombat (now Rimavská Sobota, Slovakia) in 1644, exemplifies well the great variety of these cotton materials: six sing [unit of measurement] Turkish chinatof ..., one piece of Polish cambric; nine fine linen camisoles, some from the Szepes, some Turkish and others of German cambric; one bodice of Janissary linen; 'Turkish cambric suitable for a shirt; one piece of linen from the Szepes.<sup>2</sup> It is difficult to differentiate between the various sorts of linens today. The sources demarcate three groups according to quality: the light, veil-like expensive cambric of the first order; in the second class one finds linen woven to a greater density than cambric; canvas materials of a rougher weave are relegated to the third class.

The most frequent places of origin for cambric would have been Poland, Turkey or India. Swiss,

Moravian, South German, Silesian, Dutch, Polish, Bartfean (now Bardejov, Slovakia) and Italian linen are also mentioned. Turkish or Hungarian canvas is mentioned, but was further categorized as best, medium and poor quality, as well as by additional attributes related to its suitability for a particular use, application of a pattern, or its material. These features all combined to form a name for the kind of 'linen'. By such definitions we are able to recognize 'golden or silk-edged', 'quartered', 'cotton', 'janissary', 'marrow', etc. cambric, and 'stick', 'folded', 'collar', 'thin', etc. linen, and 'janissary cotton', 'chalk', 'thick-set' canvas.

The bulya, or buja linen once belonged to these linen and cotton goods; it was of the finer category, and came to be known in Balkan languages as the Turkish woman, a Mohammedan woman, aunt, sister-in-law, a bride, etc. According to research by

Zsuzsa Kakuk, the word ‘bulya’, adopted directly and indirectly in the Hungarian language (first used in 1556) signified ‘a Turkish woman’, ‘a Turkish slave woman’ and ‘a Turkish woman embroiderer’. It was used at times to denote a feminine characteristic, and also to denote a special type of linen.<sup>3</sup> The last of these uses can be found only in the Hungarian tongue, and not in the Balkan languages or Turkish.<sup>4</sup>

*Bulya vászon* came into the country primarily by way of trade as testified by customs’ nomenclature and limitations. The list of Cambric and Linen in the conventional tariff of Transylvania made in 1620 shows that a length of bulya vászon was somewhat more expensive than fine linen, Turkish canvas and bagazia of Bursa, while Polish fine linen cost almost twice as much.<sup>5</sup> In the Transylvanian limitation of 1627, a sing of ‘good Bulya vászon’ found among

the ‘cattle imported by Turkish, Greek and Jewish merchants’ was set at the same price as a sing of ‘gilded cambric of lesser quality’.<sup>6</sup> Apart from ‘good’ and ‘lesser’ bulya vászon, a silk-edged bulya vászon was also produced.<sup>7</sup> Bulya vászon appeared regularly alongside Turkish textile goods, such as Turkish carton, bagazia and Turkish material for quilts, sold by Balkan merchants at the beginning of the eighteenth century in regions that had belonged to the Turkish empire.<sup>8</sup> Bulya vászon was bought directly in Turkey, in the cities of Istanbul or Adrianople (Edirne) on the orders of one or another aristocrat. János Gáspár bought ‘three lengths of bulya vászon’, and Pál Bornemissza bought one tablecloth sewn onto a large bulya vászon on behalf of Gábor Bethlen, prince of Transylvania (from 1613 to 1629) in Constantinople,<sup>9</sup> and bought bulya



FIGURE 1 Napkin embroidered on black bulya vászon with coloured silk thread, belonging to the Presbyterian Church of Szendrő. Ottoman Turkish, early eighteenth century, 71 x 43 cm. Budapest, Museum of Applied Arts, inv. no. 19476. Flax yarn, Z spun; warp density: 19/cm, weft density: 18/cm; width of material: 46 cm. (Photo: Katalin E. Nagy).



FIGURE 2 Detail of Fig. 1. (Photo: Katalin E. Nagy).

vászon on the orders of Mihály Teleki, the Transylvanian chancellor, in Adrianople (Edirne) in 1667.<sup>10</sup>

As regards the use of *bulya vászon*, Péter Apor's memoirs, set down in 1736, explain that according to the aristocratic fashion of the seventeenth century, youths would wear 'a shirt of fine linen or *bulyavászon*' under their shirt of chain-mail,<sup>11</sup> and that tablecloths, aprons, gowns, hussar's pelisses, foot-cloths,<sup>12</sup> bodices,<sup>13</sup> bonnets, and pants would also be made from the material. We find the purchase of *bulya vászon* for cheesecloth among the expenses of the city of Kőrös in the year 1661;<sup>14</sup> mention of wages to servants in the form of *bulya vászon* (along with linen, Turkish canvas and cambric) is also made in the register.<sup>15</sup>

*Bulya vászon* or material of its kind was produced in more places than just the Ottoman Empire. According to the thirtieth register of Kolozsvár, drawn up between 1599 and 1637, *bulya vászon* of Polish manufacture was available in addition to that from Turkey. István Eperjesi brought 'bulya vászon' from Krakow in 1632; Márton Réz transported *bulya* or nettle (muslin) material from the city of Jaroslav, Poland; and, István Eppel also imported 'csalyanj (nettle or muslin) or *bulya*' material into Kolozsvár from Krakow.<sup>16</sup>

Muslin, the gauze-like, often mottled material for undergarments that was imported from Poland and Silesia, was in general use during the seventeenth and eighteenth centuries.<sup>17</sup> The thirtieth register



FIGURE 3 Napkin embroidered on white *bulya vászon* with coloured silk thread, belonging to the Presbyterian Church of Szendrő. Ottoman-Turkish, early eighteenth century, 66 x 45 cm. Budapest, Museum of Applied Arts, inv. no. 19.472. Flax yarn, Z spun; warp density: 19/cm, weft density: 18-2/cm, width of material: 41 cm. (Photo: Katalin E. Nagy).



FIGURE 4 Detail of Fig. 3. (Photo: Katalin E. Nagy).



FIGURE 5 Turkish wrapping kerchief (*bohça*) made out of a Turban cover (*kavuk öröstü*), belonging to the Presbyterian Church of Ónod. Ottoman-Turkish, early sixteenth century, 75 x 75 cm. Budapest, Museum of Applied Arts, inv. no. 11307. Flax yarn, Z spun. Warp density: 15/cm, weft density: 17/cm. Width of material: 76 cm. The microscopic investigation of the material was undertaken by Márta Tóth, chief conservator at the Museum of Applied Arts, Budapest.

mentions it 28 times, with the earliest mention dating to 1599. In comparison, however, *bulya vászon* is only mentioned five times: twice in the case of *bulya vászon* from Turkey, once from Poland, and two notes that refer to ‘bulya, or muslin material’.<sup>18</sup>

If the available data is collated it seems that the expression *bulya vászon* was in common use in the Hungarian language to denote a gauze-like fabric irrespective of whether its composition was of cotton, flax or any other fibre, or whether it was of Turkish or any other origin, at the time that Turkish *bulya vászon* appeared on the market along with the muslin materials from Poland and Silesia. The earlier data from Kőrös, where it was mentioned as ‘cheese cloth’, seems to support the premise that *bulya vászon* was loosely woven.

Records pointing to the existence of *bulya vászon* made in Hungary, rather than in Turkey or Poland, are also in evidence. In the opinion of Márta Bur,<sup>19</sup> the *bulya vászon* of Eger, found next to the Turkish variant in the stock of merchants in

the Balkans during the eighteenth century, denotes a product made by the significant craftsmen’s colony of Serbs and Greeks living in the Hungarian town of Eger. István Sugár’s research showed that during the eighteenth and nineteenth centuries the *bulya vászon* of Eger was usually a flax [linen] material, at times woven together with cotton, whitened, unwhitened or dyed black, but it was a linen of higher weft density, with a width ranging from between 26 and 52 cm.<sup>20</sup>

The question arises as to whether it is possible to identify this type of ‘linen’, which had been used for a great variety of purposes from the costumes of the nobility to servants’ clothing and must have been different from other linens due to its singular texture. Only a textile article that can be verified on the basis of a note from the time of its origin would provide a certain identification.

Contemporary textiles of Turkish origin will on the whole only have remained extant in collections belonging to the church or museums.<sup>21</sup> In a search through fifty-nine parish inventories within the registers of canonical visitations made between 1665 and 1805 at Protestant churches in Borsod, Abaúj, Zemplén, Gömör and Torna counties, Béla Takács<sup>22</sup> revealed thirty-seven mentions of *bulya vászon* kerchiefs or covering cloths, and three of *bulya* linen (*patyolat*).<sup>23</sup> Among the registers published by the author, those taken in Szendrő and Ónod are significant for determining the nature of this material. A *bulya vászon* kerchief and a black *bulya vászon* kerchief decorated with assorted silk embroideries were found in the inventory of Szendrő from 1759; while in Ónod, among eight kerchiefs recorded in 1757, a kerchief is found that was once ‘lined, outside with yellow taffeta, and *bulya vászon* inside, bedecked with a variety of silk flowers sewn on’.<sup>24</sup> The parish collections of sacred cloths from both churches can be found at the Budapest Museum of Applied Arts,<sup>25</sup> so that each article can be identified on the basis of its description (Figs. 1, 3 and 5).

Although the inventories do not mention this, all three articles were made in Turkey. The kerchiefs of Ónod were originally napkins (*yağlık*) used to wipe the hands and the mouth, and the altar cover of Szendrő was originally the quilt cover of a turban (*kavuk örtüsü*) from which a wrapping kerchief (*bohça*) was then made. The material of each embroidered kerchief is made from loosely woven canvas with a stiffly spun flax yarn (Figs. 2, 4 and 6); this is inconsistent with the categorization of Turkish ‘linens’ from the eighteenth century published by Márta Bur, according to which the *bulya vászon* would have belonged exclusively to the category of cotton fabric.<sup>26</sup> The definition of the term given by



FIGURE 6 Detail of Fig. 5 (Photo: Katalin E. Nagy).

the dictionary of Ferenc Pápai Páriz from 1708 also backs up the notion that *bulya vászon* was a flax [linen] material: ‘bulya vászon: Zartes Geweb, dünne durchscheinende Kleidung, zarte Leinwand’.<sup>27</sup>

In an inventory of the personal effects of Pálné Wesselényi, née Zsuzsanna Béldi, drawn up after 1690 in Kolozsvár (?), the data found under ‘whitened linen articles listed’ goes as follows: ‘25 sing of bleached bulya vászon in a single roll’, which makes it clear that bulya was bleached during preparation.<sup>28</sup> The inventory also mentions the ‘loom with reed’ used for weaving white bulya vászon in other parts of Hungary, as well as in manor houses of the nobility.<sup>29</sup>

The expression bulya vászon, generally known and in use at the beginning of the eighteenth century, gradually passed out of the language with the end of

Turkish rule, and remained only among characteristic types of exotic Turkish merchandise, as for example in the literary work of József Gvadányi from 1790:

The adventures of a rural notary in Buda:  
 ‘He said: to bring me blessing he will make a gift,  
 of a Turkish pipe, numerous okka of Pasha’s tobacco,  
 bulya vászon and coffee for his mother, and a caftan’.<sup>30</sup>

Though the expression bulya vászon has gradually been erased from the language, the light type of linen with a slightly rippled surface, and loosely-woven from stiffly spun flax yarn, remained recognizable among the woven peasant cloths of southern Hungary and Transylvania under the name of Serb linen, Sada or purple linen. Gertrúd Palotay was the first to draw attention to the type of linen still known as bulya in some parts of Sárköz, in her book published in 1940, entitled *Ottoman Turkish elements in Hungarian embroidery*.<sup>31</sup> When describing the material of the so-called purple shirts (*byssus*), a typical item of traditional women’s dress in Sárköz, Edit Fél (relying on an earlier work<sup>32</sup>) remarks in a study of 1950 under the title *Women’s clothing in the Sárköz*, that:

canvas of a plain surface is in common use all over Hungary, a type of rippled canvas similar to that used in Sárköz, though of a rougher fibre is known; Hungarians are aware that this is used by the Romanian People of Kalotaszeg. Peoples of nationalities other than Hungarian also used it in villages by the Danube, in the counties of Baranya and Bács-Bodrog. We also have knowledge of it thanks to the peoples of mostly Southern Slavic origin living in the Romanian counties of Temes, Torontál and Arad. Yet the true home of this type of canvas lies to the South of Hungary, in the Balkans.<sup>33</sup>

In addition to the purple canvas, frilled canvas and sada shirts of loosely woven fabric registered in the textile collection of the Ethnographic Museum, there is also a sample of a material, akin to the purple shirts, that was collected in Decs village of Tolna county, where it was called ‘bujavászon’.<sup>34</sup> It is, therefore, true that, even if only sparsely, the expression was still in use in the 1950s, in certain settlements situated in the south of Hungary. As regards the close relation of the seventeenth- and eighteenth-century bulyavászon with the purple canvas or byssus used in the folk dress of Sárköz, there is no better proof than the Latin equivalent of bulyavászon given in the Pápai dictionary of 1708: ‘Tela coa, Coa vestis, Byssus’<sup>35</sup>



## Endnotes

- 1 For further reading compare with Emőke László, *Hungarian Renaissance and Baroque Embroideries. Aristocratic Embroideries on Linen. The Collection of the Museum of Applied Arts*, Budapest II. Budapest, 2002: 26-8; Gervers, Veronika, 'Linens and cottons'. In: V. Gervers. *The Influence of Ottoman Turkish Textiles and Costume in Eastern Europe with Particular Reference to Hungary*. Royal Ontario Museum. History, Technology, and Art. Monograph 4. Toronto, 1983: 61-4.
- 2 Béla Radvánszky: *Magyar családélet és háztartás a XVI-XVII. században*. [Hungarian family life and home management in the sixteenth and seventeenth centuries] I-III. Volume I. Budapest, 1879; Volumes II-III. Budapest, 1896. [Reprint 1986] (Hereafter Radvánszky: 1986) II. pp. 288-9.
- 3 Zsuzsa Kakuk: *A török kor emléke a magyar szókincsben*. [Remnants of the Turkish age in the Hungarian vocabulary] Kőrösi Csoma Könyvtár 23. Budapest, 1996 (Hereafter Kakuk 1996): 251-2.
- 4 Zsuzsa Kakuk: Cultural Words from the Turkish Occupation of Hungary. *Studia Turco Hungarica*. Tomus IV. Budapest, 1977 (Hereafter Kakuk 1977) p.19. Other opinions on the Hungarian meaning of the word: István Sugár suggests that 'The word *bulya* came to signify a particular cloth in Hungarian because Turkish women were famous for their linen-making, and especially their homespun, extremely fine, diaphanous materials.' *Az egri bulyavászon*. [The Bulyavászon of Eger] *Agria XXI* (1985) (Hereafter Sugár) p. 215. Edit Egyed traces the word *bulya* back to the Turkish for 'colour', the word 'boya', and ventures that the word *bulyavászon* did not primarily refer to the quality of the material, but to the vivid colouring of the embroideries (Sugár 1985: 216). Dezső Pais traces the origins of the word *bulya* back to the Turkish word 'bog', which means 'to tie, fasten' (ibid.).
- 5 Az erdélyi vámok tarifája 1620-ról. [The conventional tariffs of Transylvania in 1620] *Oklevéltár Kolozsvár története* II. és III. kötetéhez. [Archives for the History of Kolozsvár, volumes 2 and 3.] Vols. I-II. Ed. Elek Jakab. Budapest, 1888: 246.
- 6 Árucikké szabályzata 1627 és 1706 évekből. Adalékul a XVI. és XVII. század ipar- és erkölcstörténetéhez. [Regulation of prices from the year 1627 and 1706. As a point of reference for the trade and moral history of the 16<sup>th</sup> and 17<sup>th</sup> centuries] Publ.: Iván Nagy. *Történelmi Tár* [Historical Archive] 18. (1871): 215. According to the thirtieth register of Kolozsvár, for example, Lázár Örmény brought '2 rolls of canvas f 3-9' in 1614 and 1615. május 18-án Lázár Csizmadia brought '16.f. arra rolls of canvas - . 48' from 'Teor[ky] into Kolozsvár. *Kolozsvári harmincadjegyzékek* (1599-1673) [The thirtieth register of Kolozsvár] Published, introduced and annotated by Ferenc Pap. Bukarest-Kolozsvár, 2000 (hereafter: Pap 2000): 213 and 227; further examples of materials of the type of *bulya* vászon 1754: 'One roll of *bulya* vászon from Trabzon.' Kakuk 1977: 20. From the court diaries of I. Mihály Apafi (1662-1690) Prince of Transylvania, noted in 1675 'Twenty four and a half sing's worth of *bulya* vászon fl 22', brought at the festivities of Enyed for the court. Béla Szádeczky: *I Apafi Mihály fejedelem udvartartása. I. köt. Bornemissza Anna gazdasági naplói (1667-1690)* [The court of Transylvanian Prince I Mihály Apafi. Vol 1. The day to day accounts of Anna Bornemissza] (1667-1690). Budapest, 1911: 242.
- 7 Among the belongings of Ákosné Barcsay confiscated in 1661 'Two pieces of bulia vászon with silk trimmings worth three sings' *Barcsay Ákosné lefoglalt javai összeírása. 1661. május 10.* [Register of goods confiscated from Ákosné Barcsay 10 May, 1661. Publ.: József Koncz. *Történelmi Tár* 1887: 382; Trousseau of Gáborné Szegedi née Mariskó Cserei in 1716 'A couple of silky *bulya* vászon shirts'. From the registers of Mihály Cserei. Publ.: Lajos Szádeczky. *Történelmi Tár* 1903: 507.
- 8 Márta Bur: A balkáni kereskedők és árukészleteik a XVIII. századi Magyarországon [Merchants from the Balkans and their wares in eighteenth-century Hungary] (1737-1753). *Ethnographia* XCVI (1985) (Hereafter, Bur): 251-74.
- 9 Béla Radvánszky: *Udvartartások és számadáskönyvek, 1: Bethlen Gábor fejedelem udvartartása*. [Holding court and keeping accounts, 1: The court of Prince Gábor Bethlen] Budapest, 1888: 106 and 120.
- 10 *Archives of the Teleki family of the Holy Roman Empire. The correspondence of Mihály Teleki IV. 1667-1669*. Ed. Sámuel Gergely. Budapest, 1908. (Hereafter, Teleki Lev) p.165.
- 11 Péter Apor: *Metamorphosis Transylvaniae, azaz Erdélynek változása (1736)* [Metamorphosis or the Transformation of Transylvania] Ed.: Gyula Tóth. Budapest 1972: 34. Judit Veér also engages her husband Mihály Teleki, Chancellor of Transylvania, in the Purchase of *bulya vászon* for making shirts in 1670: And if there be no beautiful *bulya* vászon, ... let a search be made ... a roll of nice and thin *galos*, but not of that bad, tender kind, for it holds nothing.' Teleki lev V. 1910: 408.
- 12 Kakuk 1977, pp. 19-20.; Kakuk 1996: 251-252; further readings in *Erdélyi magyar szótörténeti tár*. [History of Hungarian words in Transylvania] Attila T. Szabó (ed.). Vol. 1: 1092-93.
- 13 In the course of his research on the bourgeois code of dress in Debreceni, Lajos Zoltai found bodices cut from 'bujavászon' in a number of 18th-century inventories. For example, silk bujavászon enough for 67 bodices was registered in the house of István Ethey Borbély in 1719. Lajos Zoltai: Debreceni viselet a XVI-XVII. században. [Dress codes in Debrecen in the 16<sup>th</sup> and 17<sup>th</sup> centuries] *Ethnographia: Népelet* XLIX 1938, 1-2, p. 292.
- 14 Áron Szilády and Sándor Szilágyi: Okmánytár a hódoltság történetéhez Magyarországon. [Archive of records for the History of Hungary under Turkish rule] *Török-magyarkori történelmi emlékek. Okmánytár I-IX*. Pest, 1863-1872 (Hereafter Szilády and Szilágyi) I (1868): 293.
- 15 Among expenses of the city of Kőrös in 1661, the woman cook was given *pulya vászon* to the value of 1 tallér instead of a roll of Turkish canvas. Szilády and Szilágyi I, p. 291; Among other things, György Mocsáry gave his servant Dóra *bulya* vászon as payment in 1676. Publ.: István Mocsáry. *Történelmi Tár*, 1892: 376.
- 16 Pap 2000: 426, 429, and 446.
- 17 Nettle linen might be either linens [cloth] woven from the fibre of nettle, or stuff made from flax or cotton. Walter Endrei: *Patyolat és posztó*. Budapest; Sugár 1985: 216.
- 18 Pap 2000: 215, 227, 426, 429 and 446.
- 19 Bur 1985: 266.
- 20 Sugár 1985: 216-20.
- 21 The most significant collections of ecclesiastical embroideries on a cotton base are now in the care of the Museum of Applied Arts (Budapest), the Hungarian National Museum (Budapest), the Museum of Scholarly Collections of the Presbyterian diocese to the west of the Tisza river based in Sárospatak and the Museum of Scholarly Collections of the Presbyterian diocese to the east of the Tisza river based in Debrecen.
- 22 Béla Takács (1930-1997), as Director of the Museum of Scholarly Collections of the Presbyterian diocese to the west of the Tisza river, and then the Museum of Scholarly Collections of the Presbyterian diocese to the East of the river Tisza, spent many years researching the material and source material of the region.

- 23 Béla Takács: Református templomok török hímzései Észak-Magyarországon. [Turkish Embroideries in Presbyterian Churches of the Northern Hungary] *Herman Ottó Múzeum Yearbook* (XIII-XIV.) Miskolc, 1975 397-413. (Hereafter, Takács 1975).
- 24 Takács 1975: 400-1.
- 25 The textile artefact from Ónod came into the possession of the Museum of Applied Arts, Budapest, in 1914, while the piece from Szendrő arrived in 1939. *IM Archives* 1914/597 and 1939/45
- 26 According to a list published by Bur (1985: 265-8), the following articles could be found among the cotton ware of Turkish and Greek shopkeepers in the regions under Ottoman control in the eighteenth century: Turkish carton, Turkish bulya vászon, bagazia, baraber's futa, Turkish winder, coloured Turkish material, quilt material and the Turkish kerchief made from the spun cotton fibres; fine Turkish linen, Turkish canvas as well as Turkish and Persian cambric, the veil and the dikta were made of flax.
- 27 Pápai Páriz, Ferenc: *Dictionarium Latino-Hungaricum et Hungarico-Latino-Germanicum*. 1708. The facsimile of the extended version published by Péter Bod Nagyszeben (now Sibiu, Romania), in 1767. Budapest, 1995: 35.
- 28 Publ. István Török *Történelmi Tár* 1899: 359.
- 29 Publ. István Török *Történelmi Tár* 1899: 361.
- 30 Selected works of József Gvadányi and Mihály Fazekas. *A magyar költészet kincsestára* 32, edited by: László Lator, Budapest, 1995, p. 90.
- 31 Gertrúd Palotay, *Ottoman-Turkish elements in Hungarian embroidery*, 1940, p. 17, footnote 73.
- 32 Edit Fél: Délszláv kölcsönhatások a Sárköz népviseletében. [Reciprocal Balkan influence in folk costumes of Sárköz.] *Délvidéki Szemle* II. 1943: 3.
- 33 *Folia Ethnographica* 1950: 11, footnote. The study also appeared in Hungarian as 'Női ruházatkódás a Sárközben'. *Ethnographia* 1991, 1 2, pp. 1-49. The author summarized the results of her research during 1938 and 1949 in Sárköz.
- 34 White sada bujavászon. Flax with black and white cotton threads woven in. 12 x 27 cm. Inv. no. 52.2.11. I would like to thank Edit Katona, the head of the textile collection of the Ethnographic Museum, Budapest, and Mónika Lackner, ethnographer, for their most practical help in the ethnographic aspects of my work on *bulyavászon* and *bíborvászon*.
- 35 Pápai Páriz, op. cit., p. 35.

The Textiles and Costumes Department of the Budapest Museum of Applied Arts has the only backgammon board with a textile covering, a feature of great rarity among board games.<sup>1</sup> While most examples of this type of object are made of special types of wood, ivory, precious metals or precious stones, the textile covering and outstanding quality of the embroidery make this artefact exceptional.<sup>2</sup> Various Venetian books of embroidery patterns printed late in the sixteenth or early in the seventeenth century may have provided the source for these pictures.<sup>3</sup> Yet in spite of an amassed puzzle of figurative and emblematic images and lines of poetry, it has proved impossible to ascertain the person who commissioned or owned the object.

[ ANIKÓ PATAKI ]

## Restoration of an embroidered board game

**T**he Hungarian name for the board game, 'os board', a term no longer used, denotes both the tools for the game (board and pieces) and the game itself, which is played on the inner, two-part face of the board. The fields for three different games are found on this 'open and shut' hinged box. Chess and draughts can be played on one of the outer faces, merrills (sometimes called Nine Men's Morris) on the other, and backgammon on the inside. The disks and pieces required for the games are missing.<sup>4</sup>

### Description

The chequered field for draughts and chess has the squares decorated with rosettes, with tulip and tendril motifs. The alternating colours of the squares are

achieved using silver and gold-coated silver metallic threads. A thin strip at the top and bottom of the board has a picture in an oval laurel-wreath frame depicting an eagle descending upon a crested fish, and another snatching it. The following text is embroidered in silver thread on a curling ribbon of pink silk extending on both sides of each laurel-wreath<sup>5</sup>:

eximan aut mergar

Aut mea iacta tam vesanis eximer undis

Dextra Crucem aut mergar strenue cesar bis  
profundissima...

Hostibus ulla tuis iam non est tuta latebra

Cernere cuncta vales vincere cuncta potes

I catch the fish or drown

Either my right arm saves the cross from the  
waves

Or let me sink with it courageously into the sea

most profound

Your enemies no longer have a haven on this earth

You see all, and can vanquish all.

The 12 mm high frame of the board carries ornamentation of a thicket of intertwining leaves. At the centre of each side, Turkish military insignia (so-called 'trophies') are placed in medallions surrounded by leaves. Flowers made with silver threads (gilded and un-gilded) decorate the side panels of the raised frame. The following lines of verse, worked in silver metallic thread, are framed in laurel-wreaths at the corners:

Freggi adu na e á lui dispone

Favorevole la sorte

Ma virtute al prode al forte

di trofei lauri e corone

He that is born for the battle

Should grab this weapon given by fate

May power and courage be his virtues

laurels and a crown will be his reward.

Ornamentation with leaves on a tendril, made from

metallic thread, fills the ground between the lines of the game of merrills. As in the case of the draughts board, pictures framed in laurel wreaths can be seen above and below the game: an eagle descending upon a seven-headed hydra, and a stag. The script on these ribbons reads:

obuia centeno

Obuia centeno que semper ger minat Hyde

Quam si vin cere quam vincere sola potes

consilio et robore

Longa corona cadesi am mente et viribus aucta

Concep toque hostis pulvere plena verit

facing the hundred heads

Facing the hydra whose hundred heads sprout

anew

For if he can be conquered, you will be the

conqueror

With brain and brawn

The awaited laurel, richly entwined by brain

and power

Coated in the dust of enemies on the run



FIGURE 1 Backgammon board, before restoration

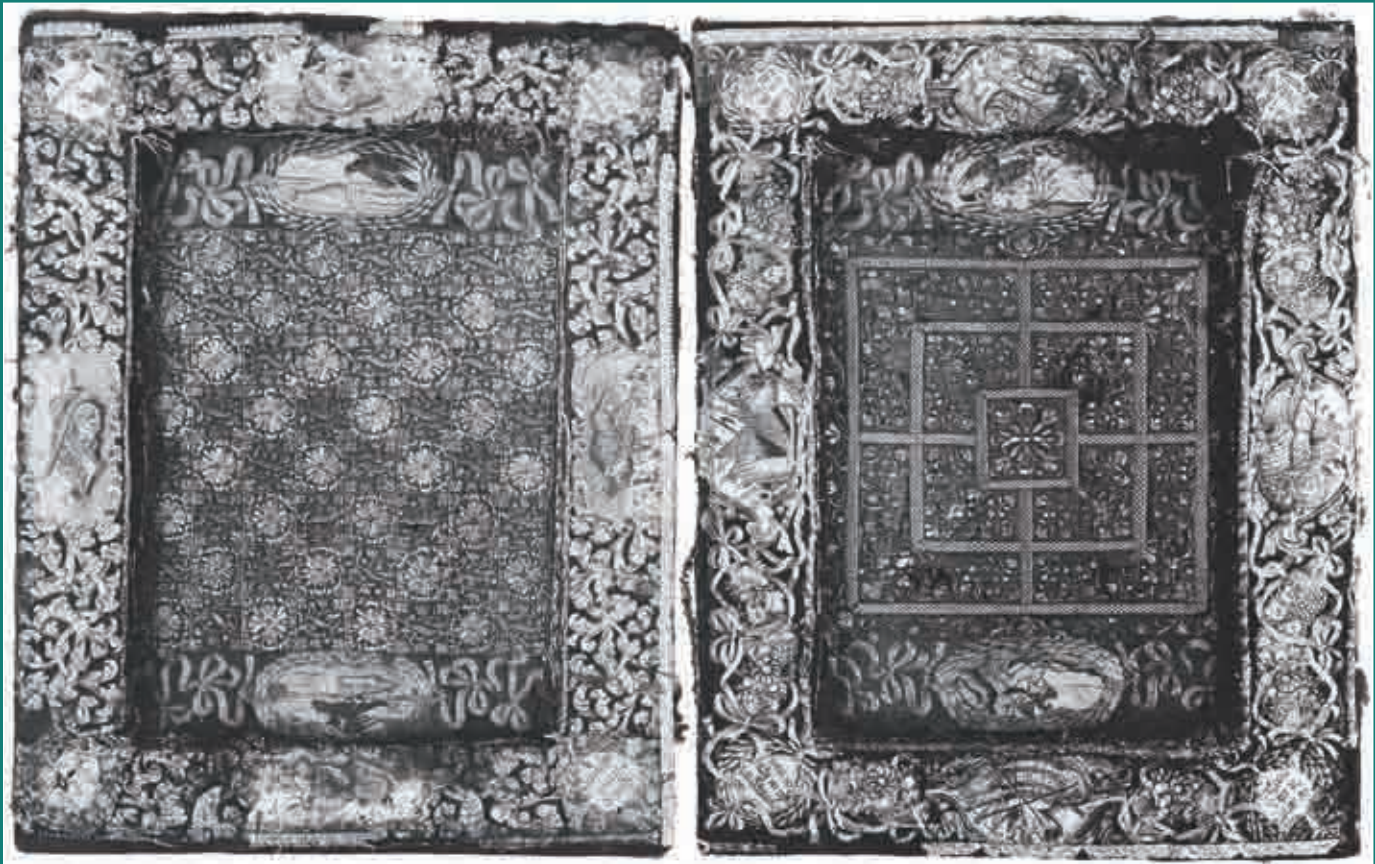

FIGURE 2 Chess and merrills board, before restoration

Turkish military insignia are represented in oval medallions at the centre of the side panels, with rich strings of flowers and fruits linked by ribbons filling the rest of the border. A rhyme can be found on each corner here, too:

Ora pace ed ora guerra  
 Giuoca il feto su la terra  
 Variamen te có i mortali  
 Maneggian do or beni mali  
 Time of peace and time of war  
 Blind fate leads the world on  
 It can bring good or evil  
 Variously on mortals

Opening the hinged board reveals the two-part field for backgammon. The characteristic acute-angled triangles of the field have been formed from floral ornamentation. Each triangle is capped with an arrowhead ending with a flower of three petals at its centre. Two wide strips partition the fields into quarters; one shows an eagle swooping upon ten nesting birds with long beaks; the other shows an eagle fighting a crane; each scene is encircled by a laurel wreath. The following scripts appear on the pink ribbons which fly on both sides of the pictures:

Animo et viribus

Hanc victricem Aquilam cernens Triumphum de  
 Victis  
 Turcis sic Sacra Musa canit  
 Odrusias depasta Feras Calvari ad culmina  
 Christum (?)  
 Deferat geminet Splendida templa Deo  
 Par numero virtus  
 Par numero virtus Volucres de cedite  
 campo et decus et vires una Tonanis habet.  
 Quo Plures hostes Celo curante Triumphos  
 Plures ista feret Screptraque plura habit  
 With strength and courage  
 The Muse sings your victory seeing the triumphant  
 eagle  
 Rejoicing over the sacred beaten Turks.  
 Chasing the beasts of Odrusias onto Christ's  
 Calvary  
 Doubting the bright temples of our Lord.  
 In numbers they are tackled by mettle  
 Your numbers are attacked by metal off the field  
 of battle,  
 His light and power are like the thunder of Jupiter.  
 The more his enemies, the more victories he wins  
 from  
 heaven, handing down more imperial sceptres.



Huge horns of plenty are placed crossed at the corners of the frames. Nine laudatory muses, with their attributes, are embroidered in oval fields in the centre. Each figure is named: Ter-psi-core, Callis-pe, Clio, Polin-n-ia and Ta-li-a, Ura-nia, Erato, Euter-pe and Melpome-ne.

## Construction of the object: materials and technology

The game in the Museum's collection is made of two boards which can be shut like a box. The embroideries are worked on a black silk rep ground fabric with coloured silk and metal threads.<sup>6</sup>

FIGURE 3 The nine muses are depicted on the frame surrounding the field of play. One of them, Urania, is shown here. The figure was embroidered with metallic threads, using the needle-painting and stem stitch techniques

FIGURE 4 Micrograph of the metal thread embroidery. The ribbons were made with a needle painting technique, while the inscriptions were fashioned from silver threads

FIGURE 5 Detail of the repaired surface of the game



The lyrical quality of the figurative, ornamental and emblematic segments worked in silk threads was achieved using a technique of needle-painting. Silver and gilded silver metallic threads were used to give form to the vegetal motifs, ribbon inscriptions, verse and the contours. Satin stitches, stem stitches, couching stitches and embroidery that imitates tabby woven fabric were used in the realization of these motifs. The rare finesse of the execution indicates that the embroidery was the work of a professional hand.

A thin, more loosely woven silk material was added beneath the ground fabric, and calico forms the stronger and thicker material of the inner lining. Bow-shaped decorations of gilded silver thread, wound around parchment, were tacked into the corners of the frames.

The base onto which the embroidered covering was applied is composed of two boards of pinewood and four frames of pine. The textiles were stuck to the wood with a starchy adhesive.<sup>7</sup> The frames and the fields of play were stuck together with glue and nailed together.

## The condition of the object prior to restoration

### The embroideries

The ground fabric, which was originally black, is in an extremely faded condition and has become dark brown. The material is very weak, aged and incomplete where there is no embroidery.<sup>8</sup> The embroideries have broken up following the deterioration and loss of the ground fabric; this has resulted in the loss of a number of motifs. Silk threads are worn away on the face of the embroidery. The colours of the threads had lost their original sheen, fading gradually and turning brown. The embroidered surfaces had become extremely dry and stiff. The dimensions of the four framing embroideries, which have become quite fragmentary, are now quite dissimilar; this is probably due to the material's drying out. The soiled surface of the object had an additional adverse effect on its appearance. The reverse side was coated with a thick layer of glue. Corrosion, of a dark grey colour, covered the silver and gilded silver metallic threads, which meant that the difference between the two types of metallic thread was hard to distinguish. The text and verse embroidered on the ribbons or framed in laurels were virtually illegible. The thread making up the flower motifs had disintegrated or become tangled. The metal strip covering the threads had crumbled in many places.

### Wooden parts

The inferior quality of woodwork and finish of the boards and frames, used as the base for the embroidery, was obvious at first sight. A rather fragmented set of imprints from Hungarian (comic) papers could be deciphered on the board which had been used to support one of the games, but no further information could be found on their date or title. The wood had dried out, the corners had split, and grown deformed. Nails joining the boards and the frames had rusted.

### Signs of repair

The assumption is that the object was repaired a number of times, though the dates of these interventions are unknown. The ground fabric's ragged condition, resulting from use, may well have given cause for these interventions and alterations. After the artefact had been dismantled, empirical evidence seemed to indicate that the embroideries had been unstitched from their original base fabric, and stitched onto new materials. Loose and disarranged metal threads were stitched down; the ground fabric was fixed with darning stitches; and, segments over the frames that had become fragmentary were



FIGURES 6-7 The front and the reverse sides of the fragmented framing embroideries, after the previous repairs had been undone



FIGURE 8 The backgammon field, after previous repairs had been unstitched and before restoration



FIGURE 9 The backgammon field, after restoration

stitched down around the edges. The fabrics, threads and stitches applied were of a varied, weak or rough quality. The hems of the material hid variances in the size of the frame and the sizes of the embroideries. Hinges and the lock were fixed to the boards with nails. It was surmised that these had been fitted at a more recent date. Embossed, gold-coated paper and braids had been stuck or stitched on to conceal the most obviously damaged parts.

## Restoration

The deteriorated condition of the embroideries and the ground fabric, deformations resulting from the folds and the aesthetically disturbing character of some later repairs made the choice of a complete restoration of the object reasonable. The fact that this intervention would necessitate the complete disassembly of the object into its constituent elements, was taken into account. Its size, as well as the state and finish of the materials making up the artefact,

gave grounds for the use of better wood to rebuild the object.

## Disassembly

The hinges and nails holding the frames, and the paper strips were removed in the first phase, followed by removal of the glue holding the frames and the boards together. Removal of the embroideries from the wooden material was the next phase. In the many areas where the glue had aged, a mechanical approach was sufficient. Where the adhesion was still strong, a moistening of the material to aid its removal could not be avoided. The pliancy of the glue could be increased, and layers separated by wetting the cloth. Previous surmises about earlier repairs proved correct: after the layers had been taken apart, a variety of fabrics of different quality used to further support and complete the embroidery became visible on the reverse side of the material. The following step was to remove this mixture of materials and stitches, to allow the realignment of the deformed parts of the original during cleaning.



## Cleaning

The initial stage of cleaning involved the partial cleansing of metal thread by softly rubbing the surface with mixture of ethanol and water (in a ratio of 1:9). Removal of the remaining glue and starch was the aim of the next phase. Placing the embroideries between two layers of plastic tulle made it possible to avoid fragmentation. A sufficient quantity of warm water was necessary for the removal of glue, and the use of enzymes to dissolve starch. Neither prolonged soaking nor the higher temperatures required for the removal of glue were advisable in view of the weak condition of the embroideries. A choice of temperature below the 30°C necessary for the optimum activation of the diastatic (starch-digesting) enzymes was made, and the material was left to soak for a shorter period. This part of the cleaning was not entirely satisfactory: the layer of starch deposited on the back of the needle-painted embroideries is visible to this day. The deposits were on surfaces that could not be accessed for mechanical action, forcing a retreat from the aim of removing all adhesive substances. Wet cleaning followed immediately and was carried out with a solution of a non-ionic detergent (Prevocel) in softened water. The pieces were left to soak for the shortest possible periods of time. The pressure of a sponge applied across the tulle removed the wash solution. After repeated rinsing in soft water, the pieces were fixed with entomological pins, carefully aligning the weave. The metal threads had regained some shine, the cloth some flexibility, and the depictions a livelier outline as a result of the cleaning.

## Providing a support fabric

A satin material was chosen as the support fabric for the embroideries, and was dyed to match the faded brown of the silk ground material used for the artefact. A black silk thread was used for stitching. The fixing of details and fragments in a variety of techniques required the use of stitches other than laid and couched stitching:

- the ground material was held in place by hold stitches and stab stitches
- the needle-painted fragments were fixed all around with tiny stitches around their edges
- for surfaces made with the couching technique, and for metal threads, the silk threads that had held them in place were replaced
- the disintegrated or jumbled metal threads composing the flowers were laid out in the space available and stitched up according to the pattern. The threads used for the satin stitch made up the realignment of disintegrated yarn.

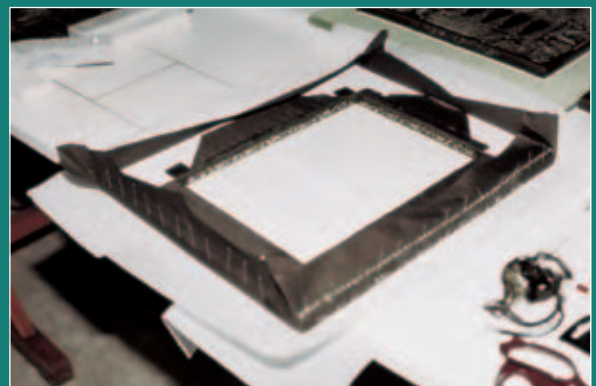

FIGURE 10 Framework embroideries pinned onto the polyfoam model

FIGURE 11 Preparation of the new frames, their covering in calico

FIGURE 12 Framing embroideries being sewn onto the frames covered in calico

FIGURE 13  
The board game  
reassembled after  
restoration



FIGURE 14  
The board game  
reassembled after  
restoration



## Reassembly

Three major conditions were to be fulfilled when the artefact was reassembled:

- a wooden frame would be made to fit the dimensions of the textile; this was desirable due to the inadequacy of the wooden parts of the object (as described in the condition report)
- it was thought best to avoid the use of adhesives this time, i.e. to avoid direct contact of the embroidery and its base material with glue
- nails were not to pass through the object when the frame and the boards were joined, and if possible the use of nails was to be avoided altogether.
- instead of nailing on the hinges (which allowed the box to open and close), a new technology was to be designed. A model would be made according to the measurements of the embroideries. A comparison of the embroideries would be made and a cardboard pattern would be prepared on the basis of the largest pieces. A polyfoam model would then be made, and each piece of embroidery would be tried on it. The polyfoam model would form the model from which a new oak frame would be made. The wooden boards, unsuitable for reuse, were replaced by 2 mm thick acid-free cardboard.

To circumvent the use of glue in reapplying the embroideries, stitching was selected. For the implementation of this choice a thin, tested and uncoloured calico covering was given to the frame.<sup>9</sup> This layer provided a firm base on which to stitch all the frame embroideries. The black silk thread used for the earlier conservation stitching was employed again. Only the edges of the ground fabric applied to the play field embroideries were stuck to the acid-free cardboard, so that the embroideries had no contact whatsoever with adhesives.

The following phase entailed joining all the listed segments together. A silk ribbon was placed between the cardboards carrying the playing fields, the ribbon stood in for the hinges used to open the box earlier. Gluing together those board surfaces and frames not covered in embroidery came second. The conservation was completed by sewing together the edges at the sides and by returning the ornamental bows to their places. The conservation was carried out by Katalin E. Nagy and Anikó Pataki.

## Bibliography

Szerves kémiai alapismeretek. [Basic Principles of Organic Chemistry] notes from the Centre for Restoration and Conservation at the Hungarian Academy of Fine Arts, Budapest, 1975.

Kastaly, Beatrix. Ragasztóanyagok a könyvkötésben, könyv és papírrestaurálásban. [Adhesive Substances in book-binding, book and paper restoration] notes from the book and paper restoration course. National Széchényi Library, 1991.

Timár-Balázs, Ágnes; Eastop, Dinah. *Chemical Principles of Textile Conservation*. Oxford: Butterworth-Heinemann, 1998.

Szilvia, Maros. Táblajátékok [Board games]. Catalogue of the Palace Museum of Nagytétény, 1982.

Bardoly, István (ed.) Barokk és Rokokó. [Baroque and Rococo] Exhibition from the collection of the Museum of Applied Arts, Budapest, 1990.

Walter, Endrei; Zolnay, László. Társasjáték és szórakozás a régi Európában [Fun and Games in Old Europe]. Budapest: Corvina, 1986.

Ripa, Cesare. *Iconologia*. Budapest, 1997. [First published 1593]

Timár-Balázs, Ágnes. Műtárgyak szerves anyagok felépítése és lebomlása. [The Composition and Decomposition of Organic Materials in Artefacts], Hungarian National Museum. Budapest, 1993.

## Endnotes

- <sup>1</sup> Storage registry no. 10.694
- <sup>2</sup> To our knowledge, no board game of a similar age or similar technique has been published, or found in collections in Hungary.
- <sup>3</sup> Maros Szilvia. Draught-board. In: Baroque and Rococo. An exhibition from the collection of the Budapest Museum of Applied Arts. ed.: István Bardoly. Budapest, 1991, cat. 2.15, p. 67-9.
- <sup>4</sup> The source of the game of backgammon, which belongs to the family of tactical chance games, can be traced back to ancient India, Iran or Egypt. The first known description of the game is found in the book of manuscripts passed down from Wise Alfons, the King of Leon and Castillia (1251-82), which gives an account of 15 versions of the game known in medieval times as tabula. Illustrations of the boards can also be found in later English manuscripts dating to the end of the thirteenth century, and in the *Carmina Burana*. The earliest extant example of a backgammon board game is also dated to the late thirteenth century; it was already in the form of a box combining backgammon with the games of chess and merrills, as board game boxes have done ever since. (Board games, the catalogue of the exhibition held at the Palace Museum of Nagytétény, Museum of Arts and Crafts. Written by the curator of the exhibition, Szilvia Maros, Budapest, 1982; Walter Endrei and László Zolnay: *Fun and Games in Old Europe*. Budapest, 1986.
- <sup>5</sup> The poems were translated into Hungarian by Mihály Détsky. In: Baroque and Rococo. Budapest, 1991. cat. 2.16, p. 67-9.
- <sup>6</sup> Identification of the materials of the embroidery threads and characterization of the morphological types of the metallic threads were conducted with a microscope with an Opton operational mechanism. Quick chemical 'spot' tests were carried out to identify the metallic makeup of the metal threads.
- <sup>7</sup> Analysis of adhesive was carried out with a starch test.
- <sup>8</sup> Disintegration was quickened by the mordant used for the dyeing. This premise could not be proven without a colour test.
- <sup>9</sup> Adhesive: Methyl hydroxide ethyl cellulose (Glutofix). Beatrix Kastaly. Adhesive substances in book-binding, book and paper restoration. Course notes for book and paper restorers, National Széchényi Library, 1991.

The shrouds, sarcophagi, cartonnages and other funeral objects that accompanied the dead to eternal life, were painted for the upper classes in ancient Egypt. The deceased, funeral masks, and protecting divinities were represented. The paintings are quite impressive and these objects have been very much appreciated since their discovery. The paintings on funeral objects are often very fragile: taken out of the relatively constant climate of the tombs, and also with the passage of time, they became very friable. Therefore, they have been subjected to many conservation treatments. These were not always very appropriate, and now the objects need new intervention. Seven painted items, a wooden sarcophagus, a wooden chest, four linen mummy shrouds and a cartonnage (all belonging to the Musées d'art et d'histoire of Geneva, with the exception of a linen shroud, the property of the Musée des Beaux Arts of Lyon, inv. 1982-100<sup>1</sup>) came to our laboratory for examination and analysis prior to conservation or purchase.

[ ANNE RINUY ]

## Conservation of ancient Egyptian painted artefacts

In the literature, references exist on the painting pigments, either on colour symbolism in ancient Egypt,<sup>2</sup> or the pigments' chemical composition,<sup>3</sup> but relatively few give information on the binding media.<sup>4</sup> It is true that the small quantities of material used, mixed later with consolidating varnishes or adhesives, complicate the analysis. Identification of the binding media is a priority and a necessity for determining a conservation treatment. So, we concentrated on this aspect, not forgetting however to look at the pigments, and at the conservation materials used. Among the objects, three had not been consolidated at all, allowing us to analyse untreated, original material. The results obtained are presented below for three types of painted objects: a wooden chest, a linen shroud, and a cartonnage.

### Brief description of the items

- a. Two painted sides of a small wooden chest, dating back to the thirteenth-eleventh century BC (New Empire). The front represents the deceased, the scribe Amenemheb, with a curly wig, adoring Isis and Osiris, and was recently offered by a generous donor (Inv. A 1998-110.35 x 19.5 cm). The back represents the same Amenemheb, but with a shaven skull, like the priests of the time, also adoring the divinities (inv. 19297, 35 x 19.5 cm) (Fig. 1). It entered our Museum 50 years ago. The chest probably contained small figures which ancient Egyptians used to take with them for eternity, to protect them and do their work



FIGURE 1 Back of a painted wooden chest, 35 x 19.5 cm, thirteenth-eleventh century BC – Amenheb adoring Osiris and Isis. Musées d'art et d'histoire, Geneva

in their place, as explained by J.-L. Chappaz,<sup>5</sup> the curator of our Egyptian collection. The painting of the back is very friable; the painting on the front had been treated with an adhesive, which has since turned brown, and which greatly disturbs the appearance of the painting. Both painted sides need a new conservation-restoration treatment.

- b. The *Shroud of Geneva* is more recent. The painted mummy, accompanied by protecting divinities is typically Egyptian, but the face is a real portrait of a woman, wearing a pearl necklace and earrings, and she is shown with a nimbus. Its execution is very influenced by Roman painting (Fig. 2). It is dated c. AD100. The shroud was bought in 1985 for the archaeological Museum of Geneva and entered later into the Musée d'art et d'histoire. It was folded and packed in a small box, where it stayed until in 1997, when it was 'rediscovered'<sup>6</sup> (inv. D 957, 140 x 240 cm). The painting was very fresh, but the shroud needed conservation treatment.
- c. Finally, the painted and gilded feet of a mummy cartonnage, also attributed to the Roman period (second century AD), (inv. A 1998-165),<sup>7</sup> had been largely consolidated with different adhesives and needed new conservation treatment (Fig. 3).

## Experimental Analysis of the binding media

Microscopic paint samples were embedded in a polyester resin<sup>8</sup> in order to prepare cross-sections. They enabled observation of the paint layers and pigments under normal and UV light.

Analyses with specific coloration and heating tests on the cross-section of the whole painting structure indicate precisely in which layer each binding medium is present:

- a. Fuchsin S, Amido Black and FITC (fluoro-iso-thiocyanate) tests indicate the presence of proteins.<sup>9</sup> Fuchsin S is most appropriate for animal glue, the coloured protein is red. Amido Black II allows the detection of egg (white and/or yoke) and casein. The coloured proteins are blue. So, it is also useful for identifying animal glue mixed with red pigments. The different aspects of the resulting blue colour depend on the protein and on the possible presence of an emulsion. Both Fuchsin S and Amido Black II contain acetic acid and have a pH around 3.5. Acidic water-sensitive paint samples, i.e. containing a vegetable gum, can dissolve in the solutions. FITC is very appropriate for

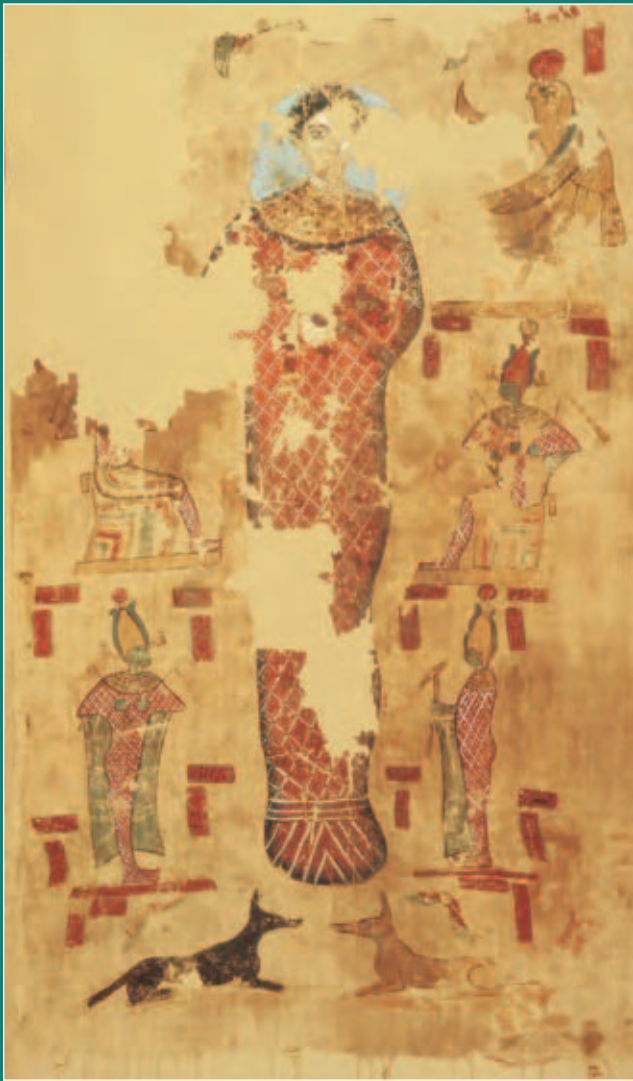

FIGURE 2 The Shroud of Geneva, painted linen, 140 x 200 cm, about AD 100 – Egyptian mummy with adoring divinities and a portrait of a woman with a pearl necklace and earrings. Musées d'art et d'histoire, Geneva

FIGURE 3 Painted and gilded foot fragments of a mummy cartonnage, second century AD. Musées d'art et d'histoire, Geneva

such cases, since it dissolves in acetone. FITC becomes brightly fluorescent under 450-490 nm UV light exposure, when bound with proteins. So it allows the detection of a protein medium even in dark colours. Though all the proteins react the same way, very small quantities can be detected.

- b. Heating tests characterize waxes, resins, oils, gums, or their mixtures, with or without proteins.
- c. Specific coloration of carbohydrates indicate the presence of gums; thin layer chromatography (TLC) can confirm their presence.<sup>10</sup>

### Analysis of pigments

- a. Mineral pigments are identified by X-ray fluorescence spectrometry (energy dispersive, EDXS) and X-ray diffraction.<sup>11</sup>

- b. Scanning Electron Microscopy (SEM), coupled with EDXS, performed on paint cross-sections indicates more precisely in which layer the pigments are present.

## Results of analysis

### Binding media

All the paintings analysed contain only a small quantity of binding medium.

The same media were identified for all the objects:

*animal glue* for the white ground, maybe with some *vegetable gum* (probably *gum arabic*) (Figs. 4-7);

*vegetable gum* for the glossy colours, some also containing a small amount of *animal glue*.

## Pigments

Calcite ( $\text{CaCO}_3$ ), and gesso ( $\text{CaSO}_4 \cdot 2 \text{H}_2\text{O}$ ) for the white ground and white colour;  
red: hematite ( $\text{Fe}_2\text{O}_3$ );  
yellow: ochre (clay containing iron oxides, such as goethite a –  $\text{FeO}(\text{OH})$ ); orpiment ( $\text{As}_2\text{S}_3$ );  
orange: realgar ( $\text{As}_2\text{S}_2$ );  
blue: Egyptian blue (similar to natural cuprorivaite [calcium copper silicate]  $\text{CaCuSi}_4\text{O}_{10}$ );  
green: Egyptian green (cuprowollastonite ( $\text{CaCuSiO}_3$ ); atacamite [ $\text{Cu}_2\text{Cl}(\text{OH})_3$ ];  
black: charcoal.

## Painting technique

The paint of the different objects has been applied in a similar manner: usually one layer of colour lying on a white ground (Figs. 4-5).

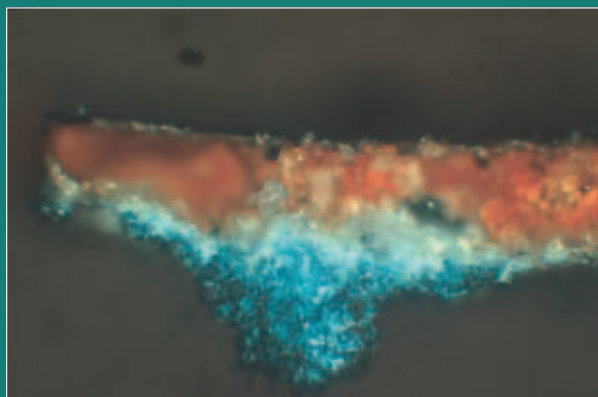
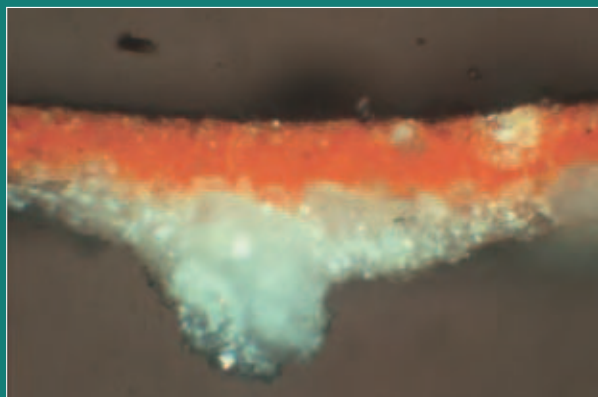

FIGURE 4 Painted and gilded feet of a mummy cartonnage. Microsample in a toe, cross-section. Red colour: hematite, thickness 100 microns ( $\mu\text{m}$ ). White ground: calcite, 250  $\mu\text{m}$ . Optical microscope, original size: 0.60 x 0.90 mm

FIGURE 5 Painted and gilded feet of a mummy cartonnage. Same cross-section as in Fig. 4. Specific coloration for proteins: Amido Black II indicating that the white ground medium is animal glue. The red colour is soluble in the acidic-specific coloration, pointing to the probable presence of a vegetable gum; Optical microscope, original size: 0.60 x 0.90 mm

The *Shroud of Geneva* differs in having no white ground: the colours were painted directly onto the primed linen textile (Figs. 6-7).

On the two sides of the wooden chest, the blue colour is made of Egyptian blue – which now appears black due to a consolidant – (e.g. in the Osiris divinity) is applied onto a red ochre layer containing charcoal (Fig. 8). The painted side was also surrounded with a blue border of Egyptian blue. In this case pigment is lying on a thin black charcoal layer (Fig. 9). So, the same blue pigment, painted on different places, had a different hue, due to the colour of the underlying layer. According to the curator, the brown-appearing layer applied onto the fragile coarse Egyptian blue can now be considered as a recently introduced consolidant, since we identified it as being a mixture of gum and animal glue and not a resin.

The cartonnage mummy had been partly gilded. The 3-4 micron thick gold foil was applied onto a fine pink bolus (about 15 micron thick), made of a small quantity of red ochre mixed with fine ground calcite. The binding medium of the bolus is probably egg white, while the thick white calcite ground is bound with animal glue.

## Conclusion

The palette of pigments used corresponds to former analyses of similar Egyptian objects.

Most interesting was to discover that the technical finesse for obtaining different values of colour, i.e. the Egyptian blue hue varies according to the composition of the underlying layer, already existed 32 centuries ago. As recently published by Klocke and Lehman,<sup>12</sup> and nearly a century ago by Raelhmann, who also analysed wall paintings and mummies of the New Empire (around 1200 BC),<sup>13</sup> this method of intensifying and modifying the blue colour of the coarse-ground blue pigments has been known for many centuries. It was believed to have appeared in Europe during the twelfth century AD, since Theophilus described the way of applying a grey or black layer, which he called ‘Veneda’. But as Klocke and Lehmann, and Raelhmann mention, Plinius already wrote about it in his *Historia Naturalis*, in the first century AD.

We could also confirm the use throughout centuries of animal glue (mainly in the white ground) and, probably, the vegetal gum arabic (mainly for the more glossy and translucent colours; animal glue gives a matt aspect) as binding media of Egyptian paintings.

The quantity of medium used is so scarce that it has been difficult to identify.





FIGURE 6 Painted Shroud of Geneva, grey nimbus around the portrait. Microsample cross-section; the grey colour (thickness 60  $\mu\text{m}$ ) is painted directly on the primed linen textile. Optical microscope, original size: 0.60 x 0.90 mm

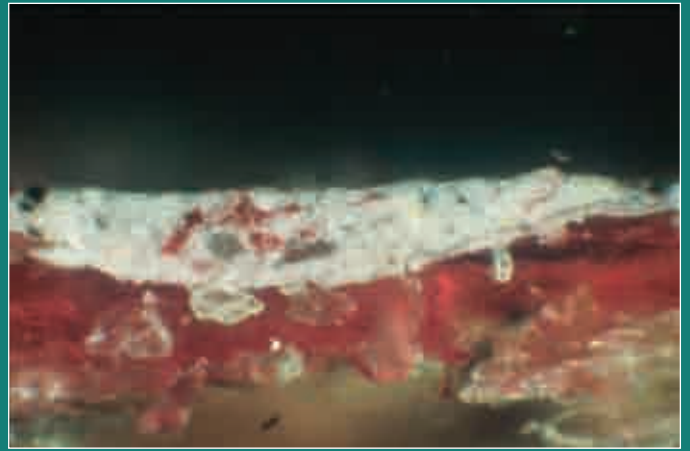

FIGURE 7 Painted Shroud of Geneva, grey nimbus around the portrait; same cross-section as in Fig. 6; Specific coloration for proteins: Fuchsin S indicating that the grey colour contains some animal glue (red filaments) and showing the animal glue-primed linen textile (red coloured fibres) Optical microscope, original size: 0.30 x 0.45 mm



FIGURE 8 Back of a painted wooden chest; Microsample in Osiris' throne; Cross-section of the blue colour; Egyptian blue (> 150  $\mu\text{m}$ ) on red ochre mixed with charcoal (10-15  $\mu\text{m}$ ). On a thick layer of a mixture of calcite and gesso (100-150  $\mu\text{m}$ ). Optical microscope, original size: 0.30 x 0.45 mm



FIGURE 9 Back of a painted wooden chest. Microsample in the blue border: cross-section of the blue colour; Egyptian blue (100  $\mu\text{m}$ ) on a charcoal layer (10  $\mu\text{m}$ ); On a thick layer of a mixture of calcite and gesso (100-150  $\mu\text{m}$ ), Optical microscope, original size: 0.30 x 0.45 mm

The use of small quantities of media, and the use of water-sensitive media, like gum arabic, has a great influence in conservation treatment: painted textiles such as the shroud of Lyon,<sup>14</sup> and so-called Shroud of Geneva, cannot be washed! We thus had to locally treat the Museum label which had been glued onto the textile just above the head of the portrait with enzymes.<sup>15</sup>

The low quantity of binding medium also leads to loss of the painting material. Most of the various water-sensitive consolidants or adhesives like animal glue, PVA<sup>16</sup> or gum arabic, were applied

onto the painting in thick layers which have now turned brown. They penetrated into original binding medium, and now probably cannot be removed from the paintings without causing further damage.

The analyses of the binding media (and of possible consolidation material) prior to any conservation treatment seems to be a continuing necessity. As already stated, the methods used do not need very sophisticated equipment and provide the conservator with sufficient information to carry on appropriate intervention.

## Acknowledgements

I warmly thank Jean-Luc Chappaz, curator of the Egyptian collection of the Musée d'art et d'histoire of Geneva, and Dr Christoph Herm, of the Swiss Institute for Art Research in Zurich, for his helpful remarks. I would like to thank the following people for their technical assistance during the analysis and for taking the photographs: Thérèse Flury, Patrizia Roncadi, Christine Dufrense, laboratoire des Musées d'art et d'histoire, Geneva.

## Endnotes

- Goyon, J.-C., 1996. Un linceul égyptien historié de la fin de l'époque ptolémaïque au musée des Beaux-Arts de Lyon. *Bulletin des musées et monuments lyonnais*, 4:14.
- Aufrère, S.H., 1999. Les couleurs sacrées en Egypte ancienne: vibration d'une lumière minérale. *Techné* 9-10:19; Colinart, S., Delange, E. and S. Pagès, 1996. Couleurs et pigments de la peinture de l'Egypte Ancienne. *Techné*, 4:29.
- Delamare, F. 1998. De la composition du *bleu égyptien* utilisé en peinture murale gallo-romaine. In: S. Colinart and M. Menu (eds) *La couleur dans la peinture et l'émaillage de l'Egypte ancienne. Actes de la table ronde*. Edipuglia, Bari, p. 177;  
Delamare, F. 1997. Sur les processus physiques intervenant lors de la synthèse du bleu égyptien. *Revue d'archéométrie*, 21:103; Coupry, C. 1998. Rapports spécifiques de la spectrométrie Raman à l'étude de la matière picturale égyptienne. In: S. Colinart and M. Menu, 1998 (eds.) *La couleur dans la peinture et l'émaillage de l'Egypte ancienne. Actes de la table ronde*. Edipuglia, Bari, p. 77; Pagès-Camagna, S. 1998. Pigments bleu et vert égyptiens en question: vocabulaire et analyses. In: S. Golinart and M. Menu (eds.) *La couleur dans la peinture et l'émaillage de l'Egypte ancienne. Actes de la table ronde*. Edipuglia, Bari, p. 163; Blet, M., Guineau, B. and B. Gratuze, 1997. Caractérisation de boules de bleu égyptien: analyse par absorption visible et par activation avec des neutrons rapides de cyclotron. *Revue d'archéométrie*, 21:121; Colinart, S. 1998. Jarosite et natrojarosite: pigment ou altération de la peinture de l'Ancienne Egypte?. In: S. Golinart and M. Menu (eds.) *La couleur dans la peinture et l'émaillage de l'Egypte ancienne. Actes de la table ronde*, Edipuglia, Bari, p. 95; Rouchon, O., Fabre, J., Etcheverry, M.-P. and M. Schvoerer, 1990. Pigments d'Egypte – Etude physique de matières colorantes bleue, rouge, blanche, verte et jaune, provenant de Karnak. *Revue d'archéométrie*, 14: 87; Morgan, H. and P. Cruickshank, 1995. The Conservation of the Shroud of Resti – an 18<sup>th</sup> Dynasty, linen *Book of the Dead*. In: C. E. Brown, F. Macalister and M. M. Wright (eds.) *Conservation in Ancient Egyptian Collections*, Archetype Publications, London, p. 1; Green, L.R. 1995. Recent Analysis of Pigments from Ancient Egyptian Artefacts. In: C. E. Brown, F. Macalister and M. M. Wright (eds) *Conservation in Ancient Egyptian Collections*, Archetype Publications, London, p. 85.
- Gottmans, S. 1999. Investigation and Conservation of an Egyptian Mummy Board from the Royal Albert Memorial Museum, Exeter. *SSCR Journal* 10(2):5; Rinuy, A. 1996. Etude de la technique picturale en vue de la restauration du linceul. *Bulletin des musées et monuments lyonnais* 4: 27; Elston, M. 1995. Technology and Conservation in Ancient Egyptian Collections. In: C. E. Brown, F. Macalister and M. M. Wright (eds.) *Conservation in Ancient Egyptian Collections*, Archetype Publications, London, p. 13; Bilson, T. 1992. The Conservation of a Roman Egyptian Painted Shroud Fragment. *The Conservator* 16:3; Viellescazes, C. and LeFur, D., 1991. Identification du liant dans la peinture murale égyptienne (Temple de Karnak). *Bulletin de la Société d'égyptologie* 15: 95; Laurin, G., 1988. In: C. E. Brown, F. Macalister and M. M. Wright (eds) *Conservation in Ancient Egyptian Collections*, Archetype Publications, London, p. 85; Hillyer, L. 1983. The Conservation of a Group of Painted Mummy Cloths from Roman Egypt. *Studies in Conservation* 29: 1; Sack, S.P., Tahk, F.C., Peters, T. and J.R. Peters, 1981. A technical examination of an Ancient Egyptian Painting on Canvas. *Studies in Conservation*, 26:15; Le Fur, D., 1994. *La conservation des peintures murales des temples de Karnak, les matériaux et les techniques*. In: Recherches sur les civilisations, Paris, p.30; Lucas, A., 1962. In: E. Arnold (ed.) *Ancient Egyptian Materials and Industries*. London (4<sup>th</sup> Ed.) p.1.
- Chappaz, J.-L. 1998. Fragments d'un bagage d'éternité. Objet du mois de mai 98. *Musées d'art et d'histoire, en collaboration avec la Tribune des Arts*.  
Chappaz, J.-L. 1999. Enrichissement du département d'archéologie en 1998, collection égyptienne. *Geneva XLVII*: 151.
- Chamay, J. 1997. Un linceul égyptien dormait au musée depuis un siècle. *Tribune des Arts*; Parlasca, K. (in press) Le linceul de Genève. *Cahiers de la Société d'Egyptologie*.
- Chappaz, J.-L. 1999. Op. cit.
- Polyester Combi 24 resin, hardener CHP 24, from Bolleter & Co AG, 9320 Arbon (CH).
- Rinuy, A. and Gros, L. 1989. Liant dans les peintures anciennes: méthodes d'identification et étude du vieillissement. Methoden zur Erhaltung von Kulturgütern. National Forschungsprogramm 16, *Zeitschrift für Kunsttechnologie und Konservierung* 1:1.
- Wolbers, R. 2000. Carbohydrates. In: *Cleaning Painted Surfaces*. Archetype Publications, London, p. 168; Flieder, F. 1968. Mise au point des techniques d'identification des pigments et des liants inclus dans la couche picturale des enluminures de manuscrits. *Studies in Conservation* 13:49.
- Rinuy, A. 1994. *Méthodes d'analyses in 'L'œuvre d'art sous le regard des sciences*. Musée d'art et d'histoire, Slatkine, Genève, p. 221.
- Klocke, J. and Lehmann, J. 2002. Technik des Unterlegens von grobkörnigen Pigmenten. *Restaurio* 5:373.
- Raehlmann, E., 1914. In: E.A. Seemann (ed.) *Ueber die Farbstoffe der Malerei*, Leipzig, p. 4. This reference was most kindly given to me by Dr. Christoph Herm, Swiss Institute for Art Research, Zurich.
- Rinuy, A. 1996. Etude de la technique picturale en vue de la restauration du linceul. *Bulletin des musées et monuments lyonnais* 4:27;  
Schoefer, M. 1996. La restauration du linceul. *Bulletin des musées et monuments lyonnais*, 4:24.
- Rinuy, A. (in press). Etude de la technique picturale du linceul de Genève, *Cahiers de la Société d'Egyptologie*; Fiette, A. 2000. Restauration d'un linceul peint redécouvert au Musée d'art et d'histoire de Genève. *Bulletin du CIETA* 77:15.
- Identified by Lugol test (KI / I<sub>2</sub> 0.1 N solution: pink colour if positive, dark blue-violet for starch); The presence of PVA was confirmed by FTIR analyses conducted by Dr. Christoph Herm, Swiss Institute for Art Research, Zurich, whom I asked to identify possible synthetic consolidants. Unpublished report, 09/05/2001.

The ecstatic reception of Albert Gayet's Egyptian discoveries at the Paris World Exhibition of 1900 went a long way to foster developments in the methods used for textile conservation and restoration in France. (Gayet's work was first supported by Émile Guimet and then the Chamber of Trade and Commerce). Conservation and restoration treatment of the finds was necessary before their exhibition to a wider public. Sadly, no documentation of the treatment was kept at the time, and so the fact such treatments did occur can be deduced only from careful examination of the objects. Scarcely any written material could be found on the restoration of the textile objects in the course of a thorough investigation of the records of the Textile Museum of Lyon. An exception is a letter dating to 1952, in which the donor of Charles de Blois's tunic, Messier Chappé, refers to the fact that he had given the tunic to Messier Robert, an employee of the Musée des Invalides with expertise in costumes, for repairs.

[ MARIE SCHOEFER-MASSON ]

## The evolution of conservation and restoration as reflected in the Coptic textile collection of the Textile Museum of Lyon

**N**ot until the more extensive investigation and restoration of two cloaks found in Antinoöpolis were carried out in 1964–65 are there any further revelations to be found on the subject. A. Geijer, senior member of the Pietas Restoration Centre in Stockholm, conducted the research, while Margit Wikland carried out the restoration of the artefacts. Sigrd Müller-Christensen, a pioneer of conservation and restoration, came to work at the Bavarian National Museum in Munich right after the Second World War.<sup>1</sup> She carried out treatment on the two cloaks from Lyon free of charge, but was lent one of

the pieces for the following twenty years. (inv. no. 34872). The restoration employed techniques still in use today, notably the use of dyed support fabrics and conservation stitching. The stitches were made with some relatively thick silk thread, and as a result are rather prominent. The use of silk crepe line seems to have begun at this time. The latter material did not, however, gain its present brown colour in the course of this restoration.<sup>2</sup> No documents referring to the treatment of these textiles were found.

In a letter dated the 4<sup>th</sup> of June 1976, M. Tuscherer, the Director of the Museum at the time, refers to Margarete Classen-Smith, with regard to

conservation carried out by her as the only French expert in the field:

Though I am full of respect for the work of Mrs. Classen-Smith, I must add, that her methods are elementary, ... She has no purpose-made equipment for the cleaning, dyeing or drying procedures ... The Abegg Foundation situated near to Bern is the lead institution in the field. I must confess, I believe that we ought to have all conservation work done abroad.<sup>2</sup>

This letter, which is addressed to Paul Bressol of the Louvre, Director of the General Purpose and Equipment Department of the Directorate of French Museums, is quite expressive of the situation of conservation in France at the time. The correspondence is due to the fact that Bressol was very much concerned with these issues, and knew the few European textile conservators, including Mechtild Flury-Lemberg, the head of the Conversation Department of the Abegg Foundation [Abegg-Stiftung]. Flury-Lemberg developed the workshop for the incomparable collection of the Abegg-Stiftung, founded in 1963, with the full understanding and support of the founder and donor. She kept up a lively professional contact with the Director of the Textile Museum of Lyon. This is what made the conservation of twenty valuable textiles in our collection possible, including the silk woven goods of Boyide [Buyid], on which she worked together with G. Viall.<sup>3</sup>

Conservation reports were not prepared; such documentation was not yet routine at the time the author joined the Abegg Foundation as a student in March of 1975. The action taken can only be deciphered by careful examination of the objects and how they are assembled, and the overall impression given by the item on display. Characteristics included the use of a thin, rather dense, dark pressed-fibre board, which was covered in a raw silk cloth of grey colour, without the insertion of a padding or insulating layer of cotton. The extremely fine silk textiles were placed under a covering of protective glass. The glass is attached with sprung metal clips, which are not conspicuous, but do exert a somewhat uneven pressure upon the mounted textiles. The same can be said about the documentation of all earlier interventions: only the frame and the means of securing the glass provide evidence that restoration had been carried out, or that some steps had been taken to ensure a more attractive appearance. (Fig.1)

Fragments now in the collection of the Textile Museum of Lyon were at times washed on the site of the excavation. They were then often mounted with glue or red sealing wax (a procedure followed for the Coptic object no. 24439 called 'Sabina's Shawl' by

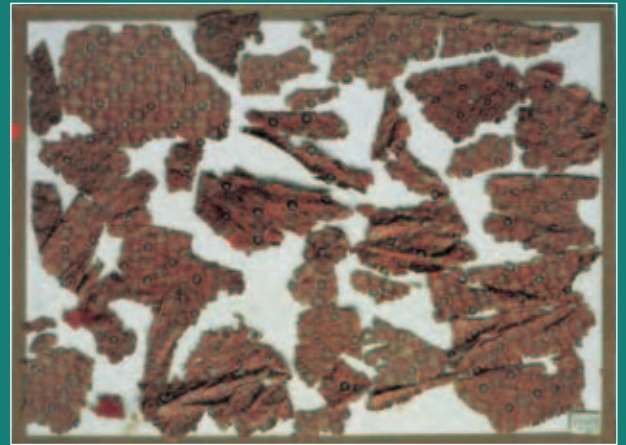

FIGURE 1 Islamic fragments from the ninth and tenth centuries (inv. no. 41664), prior to treatment in 1992. Mounting was achieved with two planes of glass, sealed with strips of paper around the edge

A. Gayet). A quotation from a letter sent by Émile Guimet, another of the great donors of Lyon, and kept carefully in Turin since 1902, is informative: 'I am sending you [...] two pieces of card, onto which I have mounted specially prepared textile fragments.'<sup>4</sup>

Based on the objects found in the Lyon collection, it becomes apparent that more than one framer worked on the collection in the 1920s. Labels found on the back of the supporting sheets, have the following inscriptions: 'Gilding, Framing, Mirror Shining, L. Roux, 2, rue Vabecour, Lyon', or 'Gilding, Mirror Shining, the workshop of Thorel, Chatelain and Bossy, 27, quai de l'Archevêché, Lyon'.

The way in which the finds were mounted at the time is indicated by their current state. The textile finds of smaller dimensions (50 x 40 cm) lay stretched without any insulation, on everyday cardboard, that has discoloured to brown with oxidation. The larger historic textiles (c. 100 x 50 cm) were stuck down with adhesive applied in a number of places. A pane of sand-blown glass was placed over the textile, and the whole assembly finished with a plain or gold-painted wooden frame. At best, a layer of new fabric was inserted between the card and the old material. Black velvet was used for the purpose sometimes, as in the case of the finds from Achmim (no. 32662 and 25236), the Dioscuro fragments (no. 22627), as well as for the Byzantine (no. 31347) and Amazon fragments (no. 27585), the latter having been bought from the Chapel of Sens treasury in 1904. The procedure was the same in the instance of no. 25957, which the museum bought from the Baron House of Paris. The procedure therefore seems to have been accepted.

Sometimes the finds were mounted upon cream-coloured fabric or satin, chosen to imitate silk; the extraordinary Byzantine fabric (numbered 27386) from the monastery of Mozac may be taken as an example of this practice. (Fig. 2) Adhesives with a starch base were also in use for mounting antique textiles. This glue was either used in spots, or more infrequently, applied to the whole surface of the material. Glass and frames were then fitted, as in the case of the Sassanid silk no. 26812/8. (Fig. 3)

More brittle fragments, with patterns on both sides, were placed between two panes of glass. The archaeologist Jakob Heirli writes at the end of the nineteenth century: ‘the new found textile materials were spread out on the ground to dry in the open air, and then placed between two panes of glass, whose edges were sealed with strips of paper.’<sup>5</sup> Many objects treated in this manner can be found in storage at the Lyon Museum.

The technique of warm gluing also crops up in places during the 1960s, but luckily, unlike in England, it was rarely used in France. It was tried

out to sad effect on one of the most significant pieces of the Textile Museum of Lyon, the ‘Fish Carpet’ numbered 28927; the label on the inner edge of the frame records the work was carried out by André Ház. The warm adhesive has left permanent marks on the treated surface, and these have darkened over time with oxidation. This side of the ‘Fish Carpet’ is also a perfectly worked surface, since the piece does not have an ‘underside’.

In the meantime, Margarete Classen-Smith also carried out textile conservation treatments in the department between 1965 and 1968 on some of the objects to be found in the cathedral treasury of Sens (the chasuble of Saint Ebbon).<sup>6</sup> It seems that she did not often work for museums, or not for the Museum of Lyon at any rate, as not a single letter or invoice has come to light. Yet she must have employed the above-mentioned technique of gluing on the veil of Saint Lazarus kept at Autun.<sup>7</sup> The then director of the Museum, Arizzoli Clémentel decided to establish the conservation workshop of the Museum in 1985. This was the first institute of its kind in France,



FIGURE 2 Fabric of Mozac (inv. no. 27386) prior to treatment in 1992. The piece was mounted on cream-coloured satin and covered with sand-blown glass



FIGURE 3 Brocade of Antinoöpolis (inv. no. 26812/1). It was framed in 1887–88 in the fashion accepted at the Textile Museum of Lyon. The piece decorated the cuff of the cloak from Antinoöpolis, which had undergone conservation treatment in Stockholm in 1965. It did not arrive at the museum together with the cloak. The decoration and the cloak are stored separately even today

founded on the model of the Abegg Foundation. The workshop carried out conservation work on the collection, which had until then been cared for in a rather simple way by framers, or handled in exceptional cases by experts called in from institutions in Stockholm or Switzerland.

In general, one finds that a much more thorough knowledge of the material effect of conservation materials and interventions became the norm all over Europe from 1980–85 onwards. The notion of washing or cleaning becomes more complex and gains in accuracy. Nonetheless, instructions do not appear in print; the techniques are passed on from workshop to workshop via expert-training courses. More suitable support fabrics are selected, and more importantly, as mentioned above, they can be dyed to blend with the original piece. The fastness of the dye is also an important matter. An increasingly aesthetic effect is sought in exhibition of the pieces, while the basic aim is to mount textile finds in the best possible way.

The methods in use at the Museum of Lyon since 1985 have taken strides to achieve these aims. Special care is also taken in the placement of the protective glass panes at the museum. It is no longer allowed to exert pressure on the fabric as had been done at earlier times. There is a preference for glass over transparent synthetic sheeting, because the latter is electrostatic, and is therefore not suitable for covering archaeological textiles. Space, of greater or lesser depth, is left between the textile find and the glass pane. Various means of placing the glass have been developed, e.g. the use of card mounts or adjustable grooves.

The conservation and restoration of textiles allows for a thorough, high-level examination of the artefacts, as well as the comparative examination of parts of any identical textiles that are held in other institutions. Museum collections of the nineteenth century can be examined more comprehensively since textiles with the complete design repeat, of the kind seen in textiles acquired by the Abegg Foundation in recent years, have entered the art market. These textiles give immense help in coming to a better understanding of the complete design of finds. The deduction and reconstruction of the connections between dispersed pieces becomes possible, as the following discussion of the fragments of a hanging will show. Publications play a particularly important role in this regard. Sad to say, there are too few publications in France.

Some textile fragments of larger dimensions were only ‘re-discovered’ in storage in 1992–93, and therefore had not been subjected to any sort of examination or treatment. Thus a number of pieces,

such as the chlamis no. 47331, still lie in the original packaging in which they were put after excavation. Neither their identification, nor their conservation has been undertaken as yet. Among them are pieces that had patterned parts cut out (a practice accepted in the nineteenth century), leaving them bereft of their context. This was what happened with the piece numbered 24439 called the ‘Shawl of Sabina’, which was bought by the Museum in 1886 from an antiquities dealer called Tano.

It is a natural stage in development that it becomes imperative to investigate or re-instate the condition of artefacts preceding the earliest attempts at conservation. Such interest gives a new importance to the hitherto unpublished accounts of earlier methods. The first conservation of a piece for exhibition often fulfils its function to the present day. It happens that real, active relationships between various museums are formed. Two-way loans of artefacts allow textiles to be made whole, while a wider range of information also becomes available. In consequence, we reaffirm that the reversibility of conservation and restoration is important. Seven textile artefacts from Antinoöpolis are introduced below as an illustration of the above proposition. These have not been published before; their investigation took place in 1999–2000, on the occasion of their conservation and restoration treatment.

## 1) Conservation of a cloth, fourth-sixth century

(Inv. no.: 28520/47. Recovered in the course of the A. Gayet excavation in 1896–97.)

Linen cloth with a pile of crimson weft yarn. Dimensions: 187 x 246 cm. (Figs. 4-5)

This large cloth has interwoven geometrical motifs placed in the corners around a double symmetrical axis. It resembles the altar cloth depicted in the San Vitale mosaic of Ravenna (sixth century). It was last used as a shroud, which explains the stains towards the centre of the linen cloth. De-restoration was necessary to reinstate its original condition.

The de-restoration did not meet with any insurmountable difficulties, since the larger, extremely fragile fragments had been fixed by simple sewing onto a highly starched, bright cream-coloured cotton material of an inappropriate quality. Despite the soiling, the composition could be deciphered clearly. The organic materials saturating the fibres were not considered hygienic for the people working with the cloth, which had never been washed, so we decided to wash it. Re-establishing the form of the cloth and supporting it were the next steps, using a large-sized linen ground fabric of a light crimson



FIGURE 4 Covering cloth from Antinoöpolis (inv. no. 25520/47) prior to its restoration in 2000, with stitches fixing it to a rough, stiff canvas

FIGURE 5 Covering cloth from Antinoöpolis (inv. no. 25520/47), following restoration



shade matching the original. The fragments and parts where the ground weave is missing were supported by stitching.

Fixing the cloth onto an appropriate mount was an important phase of the whole intervention. Such a large cloth could not be placed under glass, due to the weight of the glass. The pile of the weft yarn also precluded mounting under glass. The following solution was selected: the cloth, which had already been supported, was stitched on to a lightweight, cloth-covered board. The preparation of the board was as follows: a standard wooden stretcher frame with a diagonal support was covered with 4 mm thick card sheets. The resulting board was then covered in a double-layer, starch-free, cotton padding material, to which the supported cloth was stitched. The resulting mount is lightweight and easy to handle. The mounted cloth can be exhibited in a glass case. (Conservation and restoration were carried out by Sylvie Brun, with the guidance of Marie Schoefer.)

## 2) Cloth or cover, sixth-seventh century

(DUL 17, custodial collection of the University of Lyon. Recovered in the course of the A. Gayet excavations of 1896–97. First exhibited in Paris in 1900, prior to any conservation.) (Figs. 6-7)

Linen cloth measuring 255 x 123.5 cm with square pieces of tapestry weave in its four corners. The cloth was exhibited, in its wholly extant form, at the Lyon museum in 2000. The square panels depict scenes from the Nile with nereids and fish. Both hemmed edges, as well as the fringe composed of the warp threads, are extant. The object not only affirms the importance of Nilotic motifs, but also makes it possible to examine the way in which the square pattern was used, and the placement of the squares in the composition; in most instances these squares are the only parts to have survived.

The cloth, which had previously been indecipherable due to dirt, was washed, aligned and fixed onto



FIGURE 6 The carpet (inv. no. DUL 17) prior to the intervention of 2000, in the 'as found' state of excavation

FIGURE 7 The carpet (inv. no. DUL 17), following the intervention carried out during 1999 and 2000

dyed linen cloth. A fine, semi-transparent material (silk crepeline) was stitched onto it with great care, making sure that the decorative corners were never covered, and always remained visible. The purpose of the silk covering was to hold a number of frayed parts in place while avoiding extensive repairs directly affecting the original cloth. The cloth was mounted in a way similar to the method outline above. (Alice Vrinat and Agathe Strouk carried out the conservation and restoration work under the guidance of Marie Schoefer.)

### 3) Weaver's practice piece, fifth-seventh century

(28520/154. Gift of Émile Guimet (1907). Place of origin: Antinoöpolis.)

This piece of cloth, used as a model in teaching the weaver's craft, is made with wool weft and a linen warp. Not counting the warp yarn that has been left unwoven, its dimensions are 39 x 36 cm. The conclusion that the cloth must have been the practice piece of an apprentice weaver was reached in 2000, and a number of studies dealt with it in the years thereafter. Preparations for its exhibition took the traditional form: the mount was made by applying a layer of acid-free card to a wooden board; the mount was then covered with starch-free, cotton padding material; finally, a show fabric of beige material was applied. The object was stitched on to this show fabric, and was then covered with glass. A gap was created between the mount and the glass, so that the glass would not exert any pressure upon the object, by inserting tiny wedges under the clips holding the glass to the mount. (Conservation and restoration carried out by Denise Cotta.)

### 4) Fragments of a hanging, with column segments and a variety of patterns, sixth-seventh century

(MTL 28520/22, 23, 116 and DMBA 48, 107, 122, 123, 124. Gift of Émile Guimet (1907). Place of origin: Antinoöpolis.)

Linen cloth of greatly varying length, but with a general width dimension of 12 x 12.5 cm. It is similar to the large Dionysus hanging at the Abegg Foundation in Switzerland; common elements established between these two artefacts include: motifs, measurements and the weave count. The pieces must have been made in an important workshop of Antinoöpolis; this is confirmed by a weaving pattern at the Museum of Lyon, and by a fragment of a capital found in the Louvre in 2001 (E 28172), which bear a strong resemblance to those seen on the Dionysus hanging, and also came from the 1906 excavations



of Antinoöpolis. The fragments were each fixed separately, after they were exhibited in various forms, singly and together. The arches connecting the columns are missing on the pieces in Lyon and at the Louvre. Careful spacing of the columns was used to give the impression of the missing arches. Each fragment was then fixed in place and covered with glass, leaving an air space between object and glass. In the Lyon exhibition of 2000, the public could gain some impression of the original design of the hanging via a representation of the presumed original form of the cloth painted on the wall behind the mounted fragments. (Conservation and restoration carried out by Marie Schoefer.)



FIGURE 8 Contents of the package received from the excavations of Antinoöpolis (inv. no. DUL 35)

FIGURE 9 A fragment from a tunic (inv. no. DUL 35) after conservation in 1999 and 2000. The detail depicts the snake of Jason, or according to another interpretation, of Adam and Eve as it twines around the tree

## 5) Tunic fragments, fifth-seventh century

(DUL 35. Found in the same grave as the shawl with the inv. No. DUL 17, in Antinoöpolis, in the course of the A. Gayet excavations of 1896–97) (Figs. 8-9)

Fabric woven from linen and wool yarns. Dimensions: 12.5 x 46 cm; 35.25 x 17 cm; 20 x 6.5 cm. The two parallel edges of the tunic have a green and dark blue ground, with superimposed geometric motifs. The ground colour in the centre is Turkey red. Medallions portraying human and animal figures alternate with half star-shaped forms with floral motifs. One of the particularly finely woven motifs depicts a snake, in blue and white colours, twisting around a tree. (Fig 9) Apart from the typical Nilotic motif, there is also the rare scene of a cherub holding a duck, which allows for the two interpretations noted below. The figures can either be recognized as Adam and Eve, as shown on the cupola fresco of the fifth-century graveyard chapel of the Kharga Oasis, or as Medea and Jason, as depicted on the water jug of Lucenia (see Millingen 1813, image no. 6, p.12-13) or on one of the textiles of the Museum of Medieval Art.<sup>8</sup>

Identification of the fragments became possible during the process of restoration. Until then they had been left, still wrapped in paper, among the materials found during Albert Gayet's excavation, with the following note: find no. 35, grave no. 1377. The iconography of the fragments came to light during their washing. The weaving is exceptionally fine. It deserves mention that, following the restoration, Dominique Benezath discovered another piece of the tunic in the Louvre (inv. No. AF 5553); this suggests that the tunic was disassembled immediately after its excavation.

The fragments are individually mounted on acid-free card mounts covered with linen, without a protective glass cover. The small fragments are the remains of a tunic that is only partially extant; the placement of the separately mounted fragments is left to the discretion of exhibitors. (Conservation and restoration carried out by Marie Schoefer.)

## 6) Tunic with dancers, fourth century: five fragments kept in three museums

(MTL 28520/38; DMBA 7 and EG 2410; Louvre E 28067 and E 28072. Recovered in the course of the A. Gayet excavations of 1907 in Antinoöpolis.) (Fig. 10)

Linen cloth with decoration in wool yarn. The dimensions of the tunic when whole were: 77.5 x 146.5 cm. Pieces of the tunic were discovered over several years; their assembly, conservation and

mounting were carried out in two phases. The fragments were held in three museums. Couples dancing under arches decorate the tunic, while a row of busts decorates the area around the neck. Only work in a purple colour can be found on the unstarched linen cloth; a mottled weave achieved with the linen and the purple wool yarn, makes up the background of the silhouettes. Ochre spots of oxidation on the surface of the linen mark the positions of the bands that were used to bind the corpse buried wearing the tunic.

The conservation of the two largest pieces from the front and the back of the tunic was first carried out in Lyon in 1995, before it was known that further fragments of the tunic were in the Louvre collection. Even this first phase of conservation required the cooperation of the Textile Museum of Lyon and the

Museum of Applied Arts, Lyon, which each had to 'surrender' the fragment in its possession.

The shape of the tunic was given full consideration even for the mounting of the two fragments in 1995. The supporting linen fabric was left much larger than the fragments, and was extended to the supposed waistline. Thanks to co-operation with the Coptic division of the Department of Egyptian Art at the Louvre, three further pieces could be added to the tunic in 1999. This, however, necessitated an enlargement of the ground fabric, a modification that could best be carried out along the fold at the waistline established in 1995. New material was added to the existing support fabric along this line, and the three additional fragments were added to that.

The deductions made from certain empirical observations made during the intervention of 1995 allowed for the continuation of the conservation and restoration, without having any adverse effect on the pieces conserved in 1995. Of the three Louvre pieces, only the two fragments with the inv. numbers DMBA 7 and EG 2410, which had been restored in the nineteenth century by mounting onto card, as well as a fragment restored by Mrs. Carbonnel in 1979, by sewing on to an undyed, beige-coloured, stiff material, needed a de-conservation treatment before they could be combined with the other fragments. A tunic of discernible shape and pattern was successfully assembled from the previously scattered fragments. (The conservation and restoration were carried out by Mercédez Fernandez Alvarey and Alice Vrinat, under the guidance of Marie Schoefer.)

FIGURE 10 A tunic with dancers (inv. nos. 28520/38; DMBA 7; EG 2410; L.E. 28 072 and E. 28067) after conservation and assembly of the fragments from three different museums



## 7) Woven clavus band with painted details, fifth-sixth century

(MTL 35555. Pozzi bequest, 1971) (Fig. 11)

The object is the lower part of an extraordinarily finely woven decorative band, depicting a Nubian shepherdess with a baby on her back. Next to the shepherdess, we find two sheep grazing on a faded red background. An edge of little white waves, on a green ground, frames the image. The colour of the skin of the human figure, the pleats of the tunic and the sheep's ears are highlighted with a dark brown colour, which is painted on. The composition of the paint was analysed by Anne Rinuy, of the History Laboratory in Geneva, establishing that its base is natural brown clay, with a binding agent mixed from oil and glue of animal extraction; the paint was therefore deduced to be authentic, i.e. part of the band's original materials and construction. This piece, which is still considered unique, deserves special attention. Of course, it was never washed, as the paint is water-sensitive. It had fortunately remained in pretty good condition,



FIGURE 11 Tunic ornamentation (inv. no. 35555), linen and wool, with outline painting

so treatment was restricted to supporting it onto dyed linen cloth, and covering it with a glass pane, leaving an air space in between.

After its exhibition in 2000, Dominique Benazeth called my attention to four medallions at the Brooklyn Museum of New York with similar ornamentation (44143 a-d). A bucolic scene is shown on one of the medallions, with the woman holding her child appearing in the company of the shepherd, a flautist, a dog and other animals. Another medallion depicts a feast. We see a well, and the woman playing with her child once again on the last medallion, as well as the shepherds, and perhaps Jason, as he prepares to kill the snake twining around the tree. These four medallions also originate from Antinoöpolis, and the brown paint can also be discerned on them, just as in the case of the tunic band in Lyon. Close examination of the band during conservation led to investigation of the composition. The composition of the paint has not

been verified in the case of the medallions in New York. Another piece may have come to light at the Medieval Museum, but it has not yet been examined. (Marie Shoefler conducted the conservation and restoration treatment.)

## Conclusion

The conservation of textile artefacts being prepared for the 2000 exhibition in Lyon led to the identification of further new pieces, and provided new data on the production techniques employed by Coptic craftsmen; last, but not least, it resulted in working out new methods for conservation and restoration, and for mounting and exhibiting the textiles. The treatment provided the opportunity to reassemble fragments that been scattered over many years, treating them as single, whole objects. Research into these textiles shed light on the true significance of the excavations of Albert Gayet.

It is important to note that the interventions of our predecessors to conserve and restore objects

played a major role in the process of developing our methods. Some conclusions of fundamental importance could be reached based on examination of their work, despite the fact that not a single line of written documentation was available to provide answers to the questions that arose. Without the experiences of the nineteenth century and the early twentieth century, it would not have been possible to develop the current methods of conservation and exhibition.

I take this opportunity to thank Dominique Benazeth, who always gave inspiration, and provided valuable data in the fields of both art history and conservation history, as a person familiar with the archives of the Louvre. Finally, I would like to express my gratitude for all the expert advice given me by Ágnes Timár-Balázszy in connection with various treatments for textiles, and for the link she made between the fields of chemistry and conservation. The development of conservation and restoration is due to the cooperation between such varieties of expertise. The present study is a first attempt to outline the history of the conservation of textile finds.

## Endnotes

- <sup>1</sup> Unpublished course, held in 1975, led by Mechthild Flury-Lemberg, herself a student of Sigríd Müller-Christensen.
- <sup>2</sup> These details were confided to me in 1988 by G. Vial.
- <sup>3</sup> Flury-Lemberg, M.
- <sup>4</sup> An unpublished dissertation by Thalia Bouzid (IFROA, 2000).
- <sup>5</sup> Fiette, A. 1997. Tapestry restoration, an historical and technical survey. *The Conservator* 21:28-36.
- <sup>6</sup> Guion-Argenton, C. 1990. *Restauration de la dalmatique de Saint Ebbon*. [Restoration of the Chasuble of Saint Ebbon] IFROA (unpublished report.).
- <sup>7</sup> Valérie Marcelli, V. and Wallut, C. 2003. Le Suaire de Saint Lazare d'Autun: une restauration plus importante que prévue. *Coré: conservation et restauration du patrimoine culturel*, 14: 21-9. [Conservation of the veil of Saint Lazarus in Autun.]
- <sup>8</sup> D. Bénazeth, fellow of the Coptic department of the Louvre, brought my attention to this information in a letter of the year 2000.

## Bibliography

- Bourget, P. 1964. *Catalogue des étoffes Coptes* [Catalogue of Coptic Textiles]. Musée National du Louvre, Paris.
- Bouzid, T. 2002. *Conserver ou retirer les interventions anciennes. Etude de sept textiles islamiques médiévaux restaurés ou montés à la fin du XIXe siècle ou au début du XXe siècle*. [To keep or discard the results of earlier interventions. A study of seven textiles of medieval Islam

- that underwent conservation at the end of the 19<sup>th</sup> or the beginning of the 20<sup>th</sup> centuries.] IFROA (Unpublished study).
- Chartraire E. 1911. Les tissus anciens du Trésor de la Cathédrale de Sens [The ancient textiles belonging to the Treasury of Sens]. *Revue de l'Art Chrétien*.
- Fiette, A. 1997. Tapestry restoration, an historical and technical survey. *The Conservator* 21: 29.
- Finch, K. 1980. Changing attitudes, New developments, Full circles. In: *Conservation and restoration of Textiles*, Milan.
- Flury-Lemberg, M. 1973. Les soieries Bouyides de la Fondation Abegg à Bern [The silk fabrics in the Abegg Foundation of Geneva]. *Bulletin du CIETA* 37:11-54.
- Flury-Lemberg, M. 1988. *Textil Konservierung im Dienste der Forschung* [Textile Conservation and Research], Bern.
- Geijer, A. 1961. Méthodes dangereuses pour le conservation des textiles [Dangerous methods in textile conservation]. *Bulletin du CIETA* 13:19-26.
- Geijer, A. 1968. An Iranian Riding Coat reconstructed – Un manteau de cavalier iranien reconstitué. *Bulletin du CIETA* 27:22-25.
- Guion-Argenton, C. 1990. *Restauration de la dalmatique de Saint Ebbon* [The conservation of the chasuble of Saint Ebbon]. IFROA. (Unpublished study)
- Houpeaux, E. 1989. *Conservation et reconstruction d'un manteau dit "de cavalier iranien"*. [Conservation and repair of the coat of the so-called Iranian horseman]. IFROA. (Unpublished study)
- Lorquin, A., 1993. La conquête de la Toison d'or; une iconographie rare dans l'Antiquité tardive sur un tissu du Moyen-Age [Acquisition of the golden fleece: rare iconography from late antiquity on a medieval textile]. *Thermes de Cluny, Revue du Louvre, Etudes*.
- Martiniani-Reber, M. 1986. *Soieries Sassanides, Coptes et Byzantines Ve-XIe siècle* [Silk materials of Sassanide, Coptic and Byzantine origin, dating from the 5<sup>th</sup> to the 11<sup>th</sup> century]. Lyon, Musée Historique des Tissus de Lyon, RMN.
- Privat-Savigny, M-A. 2002. De la restauration à la conservation des tapisseries, 2<sup>ème</sup> partie, vers une plus grande conservation de l'œuvre originelle [From the restoration of tapestries to conservation: 2nd section: increasing emphasis on the preservation of the original work of art]. *CORE* 12: 51-57.
- Rutschowscaya, M. H. 1986. *Le vêtement de la période Copte, Tissus et vêtements, 5000 ans de savoir-faire. Monde antique et médiéval*. [Costumes of the Coptic period - Materials and clothes. The cumulative expertise of 5000 years. Ancient and medieval world]. Guiry-en-Vexin, Musée Archéologique département du Val d'Oise.
- Rutschowscaya, M. H. 1990. *Tissus Coptes* [Coptic textiles]. Paris.
- Schoefer, M. 1997. Cahiers de la Bibliothèque Copte [Journal of the Coptic library] 11, *Etudes Coptes* [Coptic studies] VI, 8<sup>ème</sup> journée d'études, Colmar, 1997. Paris, Louvain, Peeters, 2000.
- Stauffer, A. 1991. *Textiles d'Égypte de la collection Bouvier; Textilien aus Ägypten aus der Sammlung Bouvier*, avec une contribution de A. Schmidt-Colinet [Egyptian textiles from the Bouvier collection with a contribution by A. Schmidt-Colinet]. Fribourg, Musée d'Art et d'Histoire, Berne, Benteli Verlag.
- La conservation des textiles anciens. *Journées d'Etudes de la SFIIC*, Angers, 20-22 octobre 1994. [Conservation of old textiles. SFIIC-conference, Angers, 20 to 22 October, 1994.]
- Restauration du Patrimoine au Musée des Tissus [Conservation of the collection of the Museum of textiles]. *Les Dossiers du musée des Tissus* 6, CCIL, 1993.
- Au fil du Nil, couleurs de l'Égypte chrétienne* [By the River Nile, Colours of Christian Egypt]. Nantes, Musée Dobrée, 19 oct. 2001-2. janv. 2002.
- Égypte, la trame de l'histoire. Textiles pharaoniques, Coptes et Islamiques* [Egypt, the woven fabric of History, textile from the ages of the Pharaohs, the Copts and Islam]. Rouen, Musée des Antiquités, oct. 2002-janv. 2003.

In 2002 the Hungarian National Museum (HNM) purchased nine pieces from a set of eighteenth-century, Neapolitan Nativity crèche figures, which must have belonged to a set of many figures used to re-enact the story of Christ's birth. The HNM set consists of two Virgin Marys sitting on stools, a St. Joseph, a woman acting as midwife, two shepherds, a kneeling king, a noblewoman and an angel. (Fig. 1)

[ ENIKÓ SIPOS ]

## Figures from a Neapolitan Nativity crèche

**T**he history of setting up a Nativity scene started in the town of Bethlehem. The mystery of the Nativity has been re-enacted with statuettes, and partly with living figures, for a long time.<sup>1</sup> The art of Nativity crèches, which developed over the centuries, is called *Presepio* in Italian, *Krippenkunst* in German, and *Bethlehem* in Hungarian. The custom of putting up a manger started in Italy when Pope Theodosius (642–649) took away the wooden boards of the Holy Manger from the Muslim conquerors, brought them to Rome, and safeguarded them in the Basilica of Santa Maria Maggiore. There we find what is probably the oldest incomplete Nativity crèche, carved by Arnolfo di Cambio (c.1250–1301), with figures that are half life-size.<sup>2</sup>

In 1223, St. Francis of Assisi set up the first Nativity manger, which was surrounded by living figures. This custom became widespread from that time on.<sup>3</sup> It became a real Nativity crèche when the figures of shepherds and the three magi were added. The custom became quite popular in the fifteenth century.<sup>4</sup> The Nativity crèche, which was

initially set up only in churches, slowly spread and reached people's homes by the seventeenth century. Aristocrats rivalled each other in setting up bigger and more artistic crèches in their palaces. At first the figures of Mary, Joseph, angels, oxen and donkeys were put beside the statuette of the baby Christ in the manger. Later the scene was gradually extended with more and more figures from the story of Christ's birth.

### Nativity crèches in Naples

The largest and most artistic Nativity crèches were from Naples. The custom was probably introduced to Naples from Tuscany in the fourteenth century. At first, the Nativity crèches in Naples also consisted of a few life-size figures. Later, in addition to the three magi and their several attendants, the entire everyday life of Naples was represented with all its craftsmen, vendors and a marketplace. Naples became the true centre of crèche-making in the seventeenth



FIGURE 1, a-e. Some of the Nativity crèche figures from the Hungarian National Museum

and eighteenth centuries.<sup>5</sup> It was at that time when the production of adjustable figures started. Their height was limited to 35-40 cm instead of the life-size figures. The large, static figures, carved from one piece, appear next. These were later replaced by figures built on wire armatures with terracotta heads and wooden limbs.

They were dressed up in richly decorated clothes. (Fig. 2.) With the flexible wire braces, it was possible to position the figures in a more lifelike way, allowing more freedom in composition. The new style was created by Giuseppe Sammartino. Naturalistic representation is typical of the style in Naples. Each figure has its own personal character.<sup>6</sup> The materials of the background and the surroundings were moss, branches of wood, cork, or cardboard. The various perspectives within a scene were made possible with figures of different sizes.<sup>7</sup>

In the course of time, a specialist industry developed in Naples to make Nativity crèches. They were made by famous artists, sculptors, architects, goldsmiths and other Neapolitan craftsmen who made the crèches to order from prefabricated components; some made the limbs, others made the clothes or the small accessories, wax flowers, vegetables, musical instruments, and small objects which were called 'finimenti'.<sup>8</sup> Signed heads have been found but not all of them are authentic, as some replicas are also signed.



FIGURE 2 X-radiograph showing the inner structure of the figure

The names of several artists and craftsmen are known. One of the most important artists in eighteenth-century Naples was the sculptor Giuseppe Sammartino (1720–1793), who built complete Nativity crèches with figures and surroundings. Sammartino and his followers, Giuseppe Lori and Lorenzo Mosca (1719–1789), were leading crèche-builders in Naples in the court of Charles III. They made the most exquisite heads and excelled at artistic landscapes. Vinaccia was a famous silversmith, and he made a great deal of jewellery and small instruments. Luigi Ardia specialized in making waxwork, while Giuseppe di Lucca made vegetables and some of the shepherds' figures.

Matteo, then Giovanni Ferri, made perfectly cut, exquisite clothes, occasionally decorated with precious stones and oriental pearls. The patterns of the dresses were brought from nearby towns in Abruzzo or Calabria. They were cut according to the fashion worn by everyday citizens of Naples in the eighteenth century.<sup>10</sup> The costumes were not made of scraps. The patterns of fabric scraps would have been too large in proportion to the small figures. The fabrics for the clothes of the figures were made by specialized manufacturers in Naples, where small-scale fabrics, buttons, braids and other accessories were also made.<sup>11</sup>

## The figures from a Nativity crèche in the Hungarian National Museum

These have a similar construction to the contemporary figures from Naples. The body of the figures is made of linen tow wound on iron wire armatures. They have terracotta heads and oil-painted wooden legs. The heads were fastened to the body with a thick thread slipped through holes in the ceramic head, leading under the shoulders and to the hip. The limbs were fastened to the loose end of the wire frame through holes in the wood. (Fig. 3) The number 12 was painted on a shepherd's leg, indicating that at least the legs were probably mass-produced. (Fig. 4) No signatures were found.

Garments, which were made to match the character of each figure, were made of satin and plain-weave silk, silk velvet and twill- or plain-weave woollen cloth; the shirts were made of white cotton and linen. They were decorated with metal thread braids, embroidery, painted sequins and corrugated gilt paper. The robe-like coats, the bottoms of the skirts and aprons were braced with paper. The little coats (or only the coat fronts) were partly or



FIGURE 3 The body of the figure stuffed with linen tow and with a ceramic head, and the painted, carved wooden limbs

FIGURE 4 The method of fixing the leg and the serial number

completely lined with silk. Thin wires were placed in the hems of the dresses and cloaks in order to give them a lively appearance. Some of the tiny accessories (e.g. the shepherds' sandals, satchels and hat) were made of leather. The king's sabre is of cast bronze, covered in velvet, and decorated with corrugated gilt paper. (Fig. 5) The waistcoats (which are cut without backs) and the inner sleeves were sewn directly onto the bodies. The outer sleeves were sewn from the outer face, as the arms could not be moved, making it more difficult to dress the arms.

### Modifications, repairs

All the figures except the angels are fixed onto the base with metal pins nailed into their soles. The roughly made green bases and stools originally did not belong to the figures. They were probably made when they were removed from their original surroundings where they had been fastened directly to the base with metal pins protruding from the base. The angel's figure was probably modified and repaired on that occasion.

The angel was obviously suspended over the scene, as indicated by the two bore-holes at the wing junction with the body – the suspension point – and by the lack of any traces of suspension on the legs. The thread that had held the angel's head was torn, so the head was fixed with a small metal ring pinned

into its back. Thick aluminium wire was drawn through the ring and pinned into the wooden base, and the body was fastened to it with wires. The wings were fastened with two-two metal pins nailed from outside through the dress and cloak. (Fig. 6) The female figure, whose functions were difficult to define at first, was probably repaired or rather modified at the same time. (Fig. 7) Even before conservation it became obvious that, despite its fine, feminine hands, the figure had irregularly long and unsuitable legs. On the basis of its clothes – a long coat and trousers decorated with sequins and lace – it could have been one of the kings. After undressing it became clear that the legs attached to the feminine body were out of proportion, probably intended to match a male figure. The fact of the figure's being modified was reinforced by the undoing of the trousers, as they were found to have been originally a long skirt, which had been folded up to the knees and sewn together in a few stitches in the middle. Within the bottom piping a small piece of gold lace was found which must have decorated the hemline of the skirt.

### Condition

The clothes were dust-covered, torn, defective, and faded and stained in certain areas. (Fig. 8) The iron wire drawn into the bordering was corroded, broken



FIGURE 5 The figure of the kneeling king before conservation (after conservation see 1/a)



FIGURE 6 The fastenings of the wings and the figure during cleaning (after conservation see 1/e)



FIGURE 7 The figure of a noblewoman



and defective. (Fig. 9). The woollen materials were moth-eaten and frayed. (Fig. 10) The tow in the bodies was slightly decomposed in some cases. The terracotta heads and carved limbs were stained; the base was coming loose in some places so paint was peeling off, cracked or missing in large patches. One or two fingers had come off the hands of two figures. In some cases – like both Marys, the kneeling king and a shepherd – the arms or legs had come off the wire armature to which they had been fixed.. The halos of both Marys and Joseph were missing, with only the fastening visible on their heads. (Figure 11)

## Conservation

As the first step of conservation the dresses were taken off; then the waistcoats and elbow-length inner sleeves, which had been directly sewn onto the bodies, were removed. All of them were washed in a solution of distilled water and non-ionic detergents. They were spread out to dry or, where necessary, loosely stuffed with cotton wool covered in plastic foil and dried to shape. (Fig. 12) The frayed, ragged pieces were sewn onto support fabrics that matched in colour and fabric, and they were covered in silk crepe. The corroded iron wires from the hems were replaced with tinned, corrosion-resistant iron wires.



FIGURE 8 A shepherd and his clothes before conservation

FIGURE 9 The shepherd figure after conservation

FIGURE 10 The figure of Mary in red before conservation (after conservation see 1/d)

FIGURE 11 The figure of St. Joseph before conservation (after conservation see 1/c)



Damaged braids, laces and deformed sequins were repaired. The ripped decorations were secured; loose buttons and sequins were sewn back on. The dresses were assembled according to their original state. Finally, the outer sleeves were sewn back on from the face of the cloth.

Before cleaning the heads and limbs, the cracked, peeling paint was fixed with a solution of 2% acetone and Paraloid B72. The cleaning was executed with the method well established in the conservators' workshop in the Hungarian National Gallery, with an aqueous solution of 'Zoom' detergent. Cotton wool wound on little sticks was dampened in the diluted detergent and the stains were removed by gently wiping them off with the sticks. Detergent residue was eliminated with alcohol after the cleaning procedure was finished. The defects of the base were completed with a mixture of plectol B 500 ethyl acrylate and methyl methacrylate dispersion and chalk, then the paint was retouched with water-colours. Finally, painted surfaces were wiped off with a piece of soft flannel that had been soaked in beeswax dissolved in benzene. (Fig. 13) The legs and arms were pasted back to the wires from which they had come off with an epoxy-resin-based glue. The loose or torn threads that fixed the heads to the bodies were replaced with strong linen yarns.

Reassembly was carried out according to the original state, but the dresses and cloaks that were originally fastened to the figures with pins were not pinned again. Pins were replaced with tiny stitches. Broken fingers and missing halos were not replaced, as the aim was to preserve the original parts. Repair of defects of the painting was undertaken to restore the general aesthetic effect.

### The origin of the figures

In his book on "Christmas in the Arts", János Jajczay published a photograph of the eighteenth-century Nativity crèche of the 'Jó Pásztor Leányai' Convent in Óbuda.<sup>12</sup> In the nuns' possession there was a postcard with the following text printed on the back: *Nativity Crèche with 12 figures from Naples. Jó Pásztor Ház, Budapest, III. Szőlő utca 6.* In handwriting: *The artistic Nativity Crèche of the convent. A donation from Princess San Marco. Verbrannt, 1945.* (Fig. 14) Since the construction of the figures, the cut and the decorations of the dresses on the photograph are so similar to those of the figures in the Hungarian National Museum, and the Museum of Applied Arts, we may assume that once they belonged together and were the pieces of the convent's Nativity crèche, scattered during the Second World War.<sup>13</sup> (Fig. 15) This assumption is



FIGURE 12 The midwife during cleaning (after re-assembly and conservation see 1/b)

FIGURE 13 The figure of Mary in blue after conservation





FIGURE 14 A picture of the Nativity crèche of the J6 Pásztor Leányai Convent before 1945



FIGURE 15 Nativity crèche figures from the collections of the Museum of Applied Arts

justified by the fact that, as we know, Milena Nákó, the wife of Prince San Marco who came from Naples, supported the Jó Pásztor Church with charities, and the pair were ultimately buried there in 1926. The prince's valuable collections were taken to the Christian Museum in Budapest after the First World War.<sup>14,15</sup>

## Endnotes

---

- <sup>1</sup> Sinkó, Ferenc. 1985. Betlehemről a Magyar Betlehemig [From Bethlehem to the Hungarian Nativity crèches] In: *Új Ember*, Dec, p. 22-9.
- <sup>2</sup> Jajczay, J. & Schwarz, E. 1944. *Karácsony a művészetben* [Christmas in the arts]. Budapest, p. 48.
- <sup>3</sup> Jajczay op. cit., p. 142.
- <sup>4</sup> Jajczay op. cit., p. 147-8.
- <sup>5</sup> Jajczay op. cit., p. 52, 146.
- <sup>6</sup> Mancini, Franco. 1965. Il presepe Napoletano, nella collezione Eugenio Catello. *Forma e colore* 47: 1-5.
- <sup>7</sup> Gockerell, Nina. 1998. *Krippen in Bayerischen Nationalmuseum*. München, p. 56-61.
- <sup>8</sup> Bogner, Gerhard. 1981. *Das grosse Krippen Lexikon*. München, p. 161, 163.
- <sup>9</sup> Charles III (king of Naples and Sicily from 1734) was a great benefactor of crèche-builders.
- <sup>10</sup> Mancini, op. cit., p. 8-9.
- <sup>11</sup> Gockerell, op cit., p. 49-50.
- <sup>12</sup> Jajczay, op. cit., p. 46.
- <sup>13</sup> The figures in the Hungarian National Gallery were restored in 1979 by my textile conservator colleague Katalin Nagy and myself, providing a good occasion to compare the production technology features. The figures in the Museum of Applied Arts were restored by Katalin Sós.
- <sup>14</sup> Genthon, István. 1948. *Esztergom műemlékei*. [The monuments of Esztergom]. Budapest, 11.
- <sup>15</sup> I am grateful to all my friends and colleagues of the case study. Primarily to the Very Reverend Dr. Attila Farkas who lent me useful literature and advised me on my work; to Katalin Z. Fikó, who restored 5 of the figures from the National Museum; to Gergő Kovács and Eszter Aczél for their translations from German and Italian, and finally to my conservator colleague Gábor Hutai who took the X-radiographs.

The Loránd Eötvös University was founded by Péter Pázmány in Nagyszombat in 1635. It was known as the University of Nagyszombat until the 1770s, both in Hungary and abroad. It was moved to Buda in 1777 when the faculties of Law, Medicine and Humanities were moved to Pest in 1784.<sup>1</sup> The flags of the university were used only on festive occasions and for processions. At all other times they were displayed on the gallery in the Faculty of Law. References to the foundation and the history of the flags are found in the literature of the university.<sup>2</sup> The restoration described below was undertaken on what is considered to be the first flag of the university; it was probably made in the period around the foundation in 1635. This has been justified not only by oral traditions but also by the Baroque-style painting typical of the period of Péter Pázmány.<sup>3</sup> The fact that Nagyszombat was called Tyrnau in German, which is written in the inscription of the flag, refers to the place and date of manufacture.<sup>4</sup> I was asked to restore the university flag in 1999. Conservation began in 2000 and the project was completed in August 2001.<sup>5</sup>

NIKOLETT SZEDERKÉNYI

# The conservation of the flag of the Loránd Eötvös University

## Description of the flag

On both sides of the flag, the central figure is the patron saint of Hungary, Mary with the infant Jesus, in a painted Baroque shield. The gilt inscription around the central figure is PATRONA HUNGARIAE MATER UNIVERSITATIS TYRNAVIENSIS. There are scattered gilt leaf patterns on the face and there is an 8 cm-wide dyed ornamental stripe on the edges. The inscriptions and the style of decorations are similar to those on the first seal of the university<sup>6</sup> and confirm the assumed date of the flag. (Fig. 1)

The original construction of the swallow-tailed flag consisted of a single layer of plain-weave silk; the flag is 288 cm long and 156 cm wide. Due to the large

size of the flag, it was sewn from two pieces of silk, with the seam in the middle where the tails meet. The flag is edged with yellow silk fringes, with a tassel on each end of the swallow-tails. The ornamentation is painted onto the silk and covers the surface of the silk to different degrees. According to the traditional flag-painting technology, the painted ornaments were made with a thin ground and pigment layers, being identical on both sides.<sup>7</sup> With thin materials the paint media often bleed through to the other side of the cloth, so the ornaments were arranged in the same places on both sides except the circular inscription, where it was impossible to do this. The staining left by bleeding media makes it more difficult to read the inscription.

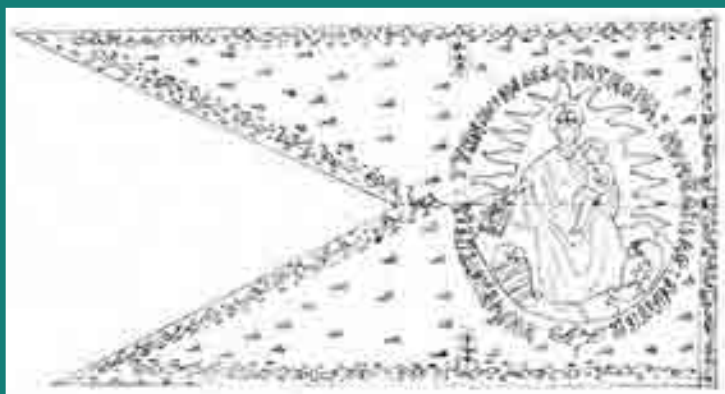
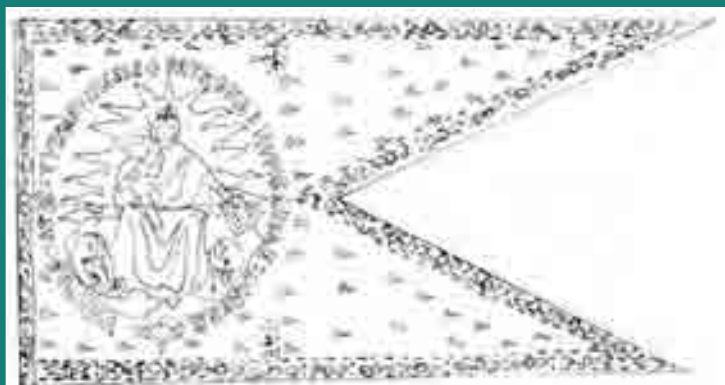

FIGURE 1 The state of the banner before conservation

FIGURE 2 The schematic drawing of the banner made of a single sheet  
a) face 1, b) face 2

The first repair to the flag was implemented in 1905. The budget for the conservation and the project outline, which describe the method of reconstruction, has been found. The reconstruction was carried out by the Viktória Flag and Decoration Manufacturing Company.<sup>8</sup> The second conservation must have been taken place in c.1920-1930, when the flag was probably sewn onto the backing net following the methods of conservation and reinforcement in use at the time.

## Condition of the flag

Several factors can influence the deterioration of materials used in making a flag. These include chemical, physical and biological changes, as well as mechanical damage resulting from use or the technology of production. A good example is when the flag was removed from display for different, important historical occasions. One such an event occurred in 1848 when the flag was handed over with the Rector's consent<sup>9</sup> to the students who were in revolt.

The repairs were visible on the flag, which was displayed in the ceremonial hall of the university. The beginning of the examination and disassembly of the flag revealed that two conservation interventions had taken place. During the first restoration of 1905, a new silk base had been glued to the whole surface of the brittle, torn, very weak and incomplete seventeenth-century flag.<sup>10</sup> The inscriptions and decorations of the original flag, which were made in a similar, but rougher style, were painted onto the glued silk base, which is similar to the original in its thickness, colour and texture. It was repainted because of the bad condition of the original silk, which needed reinforcement, and it was carried out using contemporary repair methods.

The central image of the flag was repainted at the same time, as this painted area was stiffer and thicker than the cloth of the flag, and it had cracked and broken off from the thin cloth along the painted areas. The weakened and dried layers of paint and ground had peeled off from the base. On the evidence of the repainted decoration, which was similar to the seventeenth-century originals, it was thought that the original style of depiction on the flag was truly reflected in the 1905 reconstruction.

A base cloth had been applied onto the edges under the glued silk before the re-painting, which had run through to the other side of the thin material, leaving stiff, white stains on the original, peeling gilt ornaments. During the restoration the only difference from the original style of painting was that the image was given a grey background on the ornamental decorations. The gold-imitation motifs were painted onto that, after outlining with black drying oil medium following the original technology. The peeled-off paint on the reverse of the flag was repainted, again using a drying oil medium, in the same style as in the reconstruction of the new silk base on the face. In this way the peeling layers of paint were secured, but the paint was absorbed into the ground fabric and stiffened in the course of time. This resulted in the stiffening of the decorations at the edges, so that

they cracked and fell off when the flag moved as it was being flown. The painted ornaments and the base materials were almost completely missing at the bottom of the swallow-tails on the edges. Approximately 20% of all the painted decorations on the flag had peeled off from the cloth base.

The second conservation intervention was carried out in c.1920 when the material of the repainted flag had become so torn and broken that another reinforcement was necessary. The rapid deterioration was probably caused by the gelatine used for gluing which had made both materials – the original materials of the seventeenth-century flag and the cloth base used in the reconstruction of 1905 – very stiff. The silk material had lost its softness, becoming stiff and brittle. The latter method of reinforcement was usual in the early 20th century.<sup>11</sup> The back-lining and cloth of the flag were stitched in a grid pattern with thick, rough tacking threads. Tacking was implemented quite evenly on the whole surface of the flag in 2 cm squares. The tacking stitches were worked through the painted areas, resulting in further damage and deterioration to the already weakened painted surfaces. (Fig. 2)

## Conservation

Several aspects had to be taken into account when choosing the right method of conservation. The primary aim was to preserve the original seventeenth-century material. The method chosen and the materials used for treatment are all reversible, i.e. they can be removed without damaging the object. There are painted decorations on both sides of the flag, so a backing-reinforcing method had to be chosen which makes both sides visible and also supports the weakened base. The conservation of the flag was identical in many respects to the general methods of textile conservation.<sup>12</sup> The conservation of the painted surfaces of the flag is partly identical to and partly different from the reconstruction of paintings on canvas.<sup>13</sup> In the case where decorations are painted on the material of the flag itself and the painted surface cannot be separated from the cloth of the flag, different methods must be used.

### Removal of earlier treatments

After unstitching the fringes, the tacking threads used to fasten the second conservation were removed. This revealed an additional and more faded layer of paint under the cracked painted decorations. The original gilt decoration and the inscription under the reconstructed painting were exactly overlapping. (Fig.3) Today even the reconstruction from 1905 bears a

special art-historical value; while separating the two layers we considered it important to preserve intact both the silk bases from the seventeenth century and from 1905. The condition of the seventeenth-century base under the gluing was not visible, so we chose the most careful method to make it possible to separate the two bases without causing damage.

In separating the two sheets of the flag, a method was chosen which is not often used in the conservation of flags but more usually applied to protect painted surfaces in the conservation of paintings. The painted sheets were separated without any damage by gluing *Novotex*-impregnated paper onto the cloth with gelatine. First the silk layer which had been glued to the face during the earlier conservations was slightly dampened with a sponge, so the gelatine (used for gluing the two layers) swelled and could be easily removed mechanically with a scalpel. Then, proceeding from the edges inch by inch, silicon release paper was inserted between the layers and *Novotex* was laid on the base glued in 1905. A 5% gelatine solution was applied onto the outer layer of silk which stuck to the *Novotex*. (Fig.4)

The glued silk was removed after the gelatine had dried, and the cloth was rolled onto a paper cylinder of large diameter. In this way, the remains of the original flag were distinguished and separated from the base of 1905, and both were preserved. The imperfections of the original flag became visible after the separation of the two layers. (Fig. 5)

At this stage of treatment it turned out that the original central figure, which had been covered, was missing. The main problem for the aesthetic reconstruction of the seventeenth-century flag was the missing figure. The following options were possible: (1) to repaint and reconstruct the missing figure,

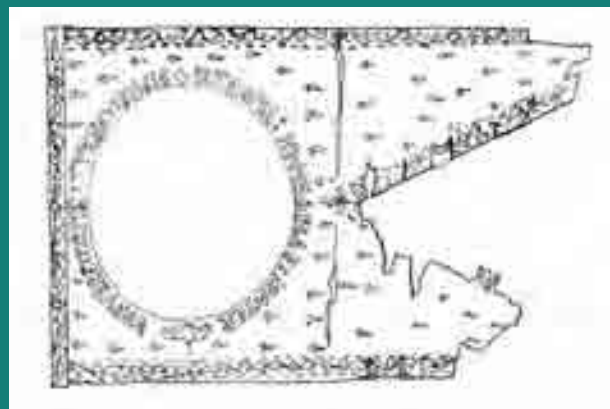

FIGURE 3 The remains of the seventeenth century banner

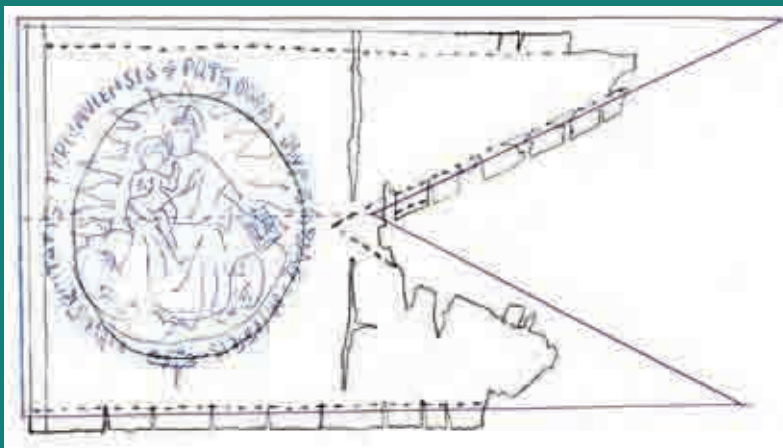

FIGURE 4 In 1905 face 1 was covered with a new silk and the picture was re-painted

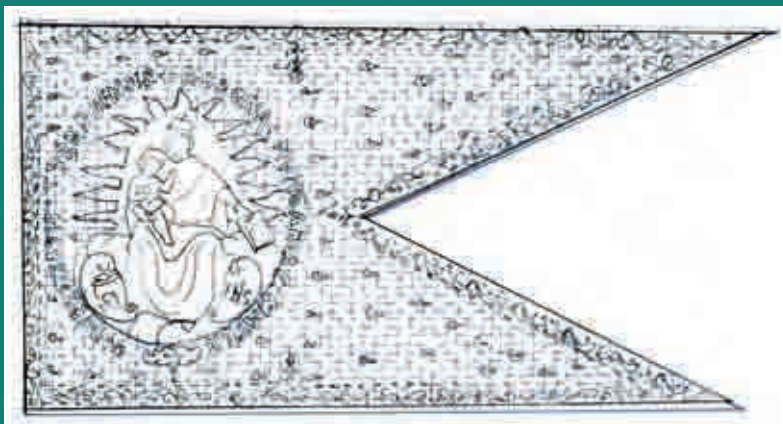

FIGURE 5 In 1920 the textile was conserved with additional stitching

using as a model the nineteenth-century figure which was a faithful representation of the original, using the technique of the original painting; (2) to put back the reconstructed figure of 1905 which slightly differs from the original in technique, but it is a faithful representation and is part of the history of the flag and the period. We chose the latter option, because the style of the painted surface on the reverse would reflect the conditions of 1905 just like the central figure. The reason for this was the inseparable layer of paint which had developed from the overlapping of the peeling layers of paint during the first conservation. The separated central figure of 1905 broke off from the secondary face of the flag in one piece along the painted surface due to its stiffness. In this way it became possible to treat it separately. (Fig.6)

After the removal of these repairs and additions, it was obvious that, apart from tears resulting from the natural ageing of the silk base, there was also some sharp disintegration due to mechanical damage

and losses of different sizes and shapes. The central and bottom parts of the flag were in the worst condition, due to the hanging and moving of the flag; the swallow-tails were the most incomplete and torn.

## Cleaning

### Preparation of the silk base

Before the original surface was cleaned, the base was glued with 'paper cloth' (*Novotex*) using the method outlined above. The gelatine that was left on the surface was enough to carry out the treatment, so a double coating of gelatine was avoided. The advantage of this method is that even the tiniest, torn pieces that are not fixed would not move from their place. The rolled-up and glued flag was put on a suitably large piece of tulle and placed in a washing tray, where it was slightly dampened, and the glued layers were removed; then the material was prepared for cleaning.

### Preparation of the painted surfaces on the base

The painted gilt decorations are quite sensitive to humidity, so before cleaning both sides needed surface protection. The dried and weakened layers of paint were treated with an 8% solution of polyvinyl-butyro-acetate consolidant (*Regnál S-1*) and ethanol.<sup>14</sup> The consolidant was ironed onto the surface between silicon paper sheets, so the layer of paint was fixed on the base, developing a thin coat on the surface, which enabled wet cleaning.<sup>15</sup>

### Cleaning of the base fabric

The brittle, dried silk was soaked in a fatty alcohol-sulphate washing liquid, and cleaned with foam applied with cotton-wool.<sup>16</sup> The swollen gelatine that remained from the earlier gluing could be removed mechanically by scraping it off. After several rinses, the reverse was cleaned in a similar way to the obverse of the silk. It was dried after the silk was carefully aligned according to its weave and dimensions. The gelatine remaining in the fabric made it slightly stiff, but the silk was smooth, and had become lustrous and soft again

### Cleaning of painted surfaces

The painted layers were softened and cleaned with ethanol; then the remnants of the white ground, which had run into the other side, were cleaned mechanically after careful dampening. During the 1905 conservation the silk was only stuck to the face, which was repainted; the original reverse was painted over in thick coats. So the base materials on the painted reverse became brittle and dry. The very



strong solvents required to remove thick coats of paint would have caused further damage to the material, and as it was not possible to remove the thick paint completely, the reverse was left untouched, leaving the thick painted layers in place.

### Gluing conservation

The cleaned, painted surfaces were consolidated with *Regnál* solution; after drying, the paint surface was ironed between sheets of silicon release paper. The *Regnál* used for gluing can be removed at any time after drying by wiping it with ethanol. So the torn base, fastened to the backing crepline, was taken out from the washing tray and turned face-up. The reconstructed figure, of Mary with the infant Jesus, was put back in place after a separate treatment. (Fig.7)

### Reconstruction of the central figure of Mary with the infant Jesus

The painted surface was dry, brittle and peeling off from the base on both sides due to the natural ageing process. The stiffer central figure had broken in several places in a few centimetre-long areas due to its movement and several smaller parts broke out of the figure. The distorted, wavy surface was covered with dust and darkened layers of lacquer and was also damaged by the needle holes of the earlier stitching. The extremely torn and incomplete silk next to the painted sun was fastened with gluing using paper cloth and gelatine after it was unstitched from the netting, and it was cleaned in a similar way to the base materials. The darkened layers of lacquer and dust on the painted surfaces were removed with the 'Brussels' mixture of solvents used in restoring paintings (30% ethanol and 70% stain-remover).

Peeling layers of paint were secured by applying and then ironing *Regnál* onto the surface. As a result, the layer of paint was fixed; the distorted, wavy painted area became smoother and elastic, and lost its rigidity. The broken parts were glued on the edges using crepline strips and they were ironed. Smaller imperfections were repaired with supported silk on both sides, with narrow crepline strips glued on the edges and ironed out so broken painted surfaces were levelled. The gaps of the incomplete and peeled-off coats of paint were completed with an elastic, diluted grounding paste on either side of the figure.<sup>17</sup> Aesthetic reconstruction was carried out first with retouching in water-colour paint; this was followed by lacquering the surface; the procedure was completed with retouch in oil paint.

### The backing method

As the flag was made with a single layer of silk, which was weak and torn, we chose a method which combines support with keeping both sides visible. That is why we supported the ground fabric between two layers of crepline with sewing conservation while the painted surfaces, edges, leaf patterns and the inscription were preserved with 'gluing conservation'. The crepline (which was sewn from two pieces) was laid out on the reverse of the cleaned flag with the seam in the middle of the face of the flag, as also on the base. The next stage was to fasten the painted areas on the reverse and the central figure of the flag onto the base.

### Completion of missing parts from the base:

The gaps in the ground fabric were 'completed' with pure silk which was similar to the original in



FIGURE 6 Detail of the inscription before conservation



FIGURE 7 Details of the inscription: the original (left) and the consolidated one from 1905 (right)



FIGURE 8 A motif from the original surface (middle), and the re-painting made in 1905 which hid the seventeenth century surface (left)



FIGURE 9 Figure of the Madonna which was painted in 1905 to replace the missing original (lower part), and the remains of the original (upper part)

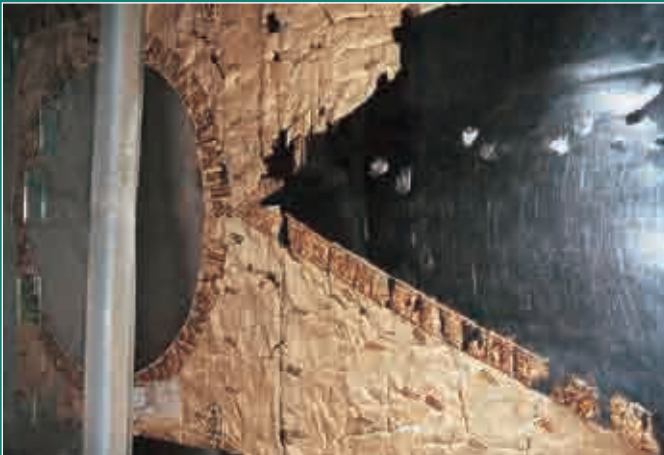

FIGURE 10 Face 2 of the seventeenth century banner after cleaning, with the empty space where the original painting was



FIGURE 11 Face 1 of the banner after cleaning, with the painting made in 1905

thickness and texture. The gaps of the cleaned base fabric were ‘completed’ with silk of a similar shade sewn with an edge seam. The silk insertions were dyed to the faded shade of the flag with natural dyes (green tea and aqueous walnut mordant). The glue residues in the base made the silk of the flag more rigid than the dyed silk insertions. Therefore the dyed silk was soaked in starch, then ironed after drying, so it became as stiff as the base. The gaps were completed with patches cut to size from the silk, which had been prepared as outlined above, and thereby the aesthetic reconstruction of the base was completed. The inserted patches were secured with sewing stitching (‘sewing conservation’).

### Completion of missing parts from the painted base fabric

The side of dyed silk which was to be fastened to the reverse of the flag and which was dyed to the shade of ornamental decorations running along the edges and of the inscription was coated with a grey elastic paste. After this preparation, the silk was identical in colour and strength with the painted surface it was intended to ‘complete’. After the gaps of the base fabric had been ‘completed’, the patches and the painted surfaces were fixed with ‘gluing conservation’ through crepeline spread over the face.

### Sewing conservation

The completed sheets of the flag were put between

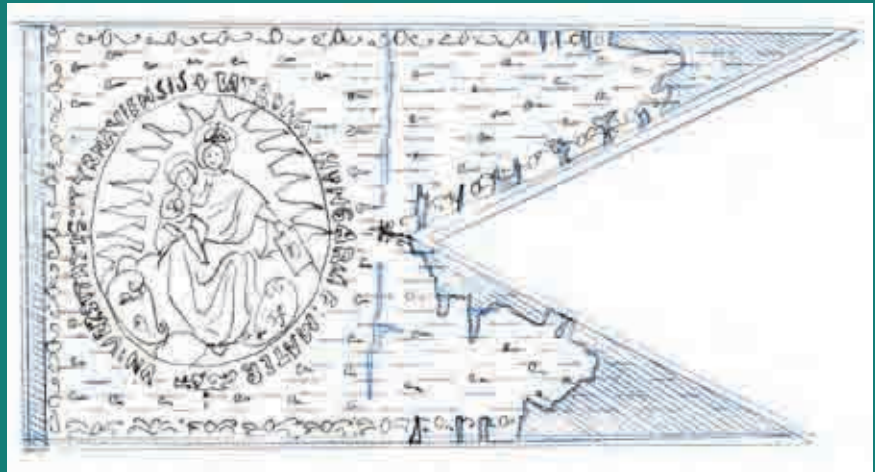

FIGURE 12 Detail of the lower swallow-tail with the reconstruction of the missing decoration (upper part) and the conserved original decoration (lower part)

FIGURE 13 The schematic drawing of the banner conserved in 2000, stitched between two crepeline layers, with the painting made in 1905

two layers of crepeline and sewn together along the direction of suspension on the whole surface with ‘sliding’ tacking stitches so that the weight of the flag would be evenly spread. The spacing of the tacking lines, carried out with silk thread, is 4 cm; the seams are approximately 25 cm long. The deep stitches of the seam were perpendicular to the ‘completed’ gaps and tears but the distance between the lines is 3 mm. The spacing of stitches is determined by the condition of the flag’s material. The direction of stitches and the very thin silk threads are hardly visible and do not stand out from the fabric of the flag.

### Aesthetic completion of painted surfaces

During the aesthetic completions and reconstruction of the completed and supported flag, the shabbiness of the existing painted surfaces was taken into consideration. The peeled-off paint was completed with diluted, tinted grounding paste which was applied onto the surface with brushes. Due to the different styles on the face and the reverse of the flag, the aesthetic completions were carried out in two different ways, according to the original state from the seventeenth century and the repainted condition from 1905.

We applied the diluted, tinted grounding paste in the silk ‘completions’ of the face and in the swallow-tails, as well as in the missing painted strip near the pole according to the missing patterns and the seediness of the existing ornaments. The distinctive retouching applied on the grounding was made with water-colour and shell gold. The retouched surfaces

were brushed with the same consolidant that was used to protect the painted surface. (Fig. 8)

The grounding of the painted surfaces on the reverse was implemented in a similar way; the only difference was that the continuous grounding was made in the style of the repainting. The continuous grey background of the ornaments at the edges was retouched in distemper and shell-gold, due to the volume of the painted decorations to be ‘completed’. The surface was brushed with the same consolidant as the face.

A 10-cm wide, grey, plain-weave cloth was sewn onto the pole edge of the flag; this cloth was folded back and the flag was fastened to the pole via this strip.

## Summary

As a result of our work, the original flag of the university (which can be considered as part of our cultural heritage) came to light and became visible from its previously covered state and was returned to its place of safekeeping. (Fig. 9)

## Endnotes

- 1 Sinkovics, I. (ed.) 1985. *Az Eötvös Loránd Tudományegyetem története 1635-1985* [The History of the Loránd Eötvös University], Budapest, p. 21.
- 2 Diószegi, I. (ed.) 1989. *Az Eötvös Loránd Tudományegyetem Bölcsészettudományi karának története 1635-1935* [The



FIGURE 14 The banner after conservation

history of the Faculty of Humanities of the Loránd Eötvös University], Budapest, p. 26.

- <sup>3</sup> Papp, J. 1982. *Hagyományok és tárgyi emlékek az Eötvös Loránd Tudományegyetemen. Fejezetek az Eötvös Loránd Tudományegyetem történetéből* [Traditions and relics from the history of the Loránd Eötvös University], Budapest, p. 89-94.
- <sup>4</sup> The conservation of the banner was initiated by the previous and current Rectors, Dr Miklós Szabó and Dr István Klinghammer.
- <sup>5</sup> Using the original, 17th-century method.
- <sup>6</sup> Papp, J., op. cit., p. 91.
- <sup>7</sup> Lakiné, Tóth, I., 1988. 18-19. *Századi magyarországi festett, illetve hímzett hadizászlók művészettörténeti és restaurálási problémái* [The problems relating to the history of art and conservation of dyed and embroidered military flags in the 18<sup>th</sup>-19<sup>th</sup> century Hungary], ELTE BTK Dissertation, Budapest, p. 4.
- <sup>8</sup> *Egyetemi Levéltár Gazdasági Igazgatóság Iratai* [Documents from the Economic Directorate of the University Archives] 1905, p. 256; Papp (op. cit.) mentions two reconstructions, one in 1899 and the other in 1905. The documentation quoted obviously proves that the conservation in 1905 was the first one.

'Budget: for the Hungarian Royal University. An old, torn university flag in bad condition, made from white silk, gilt dyed ornamentation on both sides all around, in the middle of both sides Mary, the patron saint of Hungary is depicted, there is a painted Baroque shield around her, one of them is with 5 red and 4 silver stripes and the other is with three green hills on a red base, the hill in the middle is with a crown and a double silver cross emerges from it. The circular inscription of the image is gilt and reads: Universitas Tyrnaviensis Patrona Hungariae Mater. The pole of the flag was made of soft-wood, it is painted black at the bottom, with a red globular decoration above on which there are red and white painted stripes. The spear is wrought-iron, IHS and there is a cross gilt with real gold over it.

The reconstruction of the above-mentioned flag: The base of the flag is made from new white silk, and the old flag

will be fastened on it. The new face of the flag will be artificially aged to produce an effect of the colours similar to the old flag. The next stage is to repair the ornaments, figures and inscriptions similar to the old flag. The old flag will remain on the reverse and the missing parts will be completed according to the old methods. The pole will be left intact. The whole budget of the reconstruction, including any expenses and materials is 570 koronas. The deadline is 6 weeks from the date of the order. Yours faithfully, Budapest, 13<sup>th</sup> March 1905, Viktória Flag and Decorations Manufacturing Company. Rumbold s. R.'

- <sup>9</sup> Szentpéterffy, I. 1935. *A Bölcsészettudományi Kar története 1635-1935* [The History of the Faculty of Humanities], IV. Budapest, p. 372.
- <sup>10</sup> See Note 8.
- <sup>11</sup> Lewis, G., Muir, N. and N. Yates, 1983. Festmények és festett textíliák közötti kapcsolatról [The connection between paintings and dyed textiles]. *Múzeumi Műtárgyvédelem*, 12.
- <sup>12</sup> Jedrzejevska, H. 1982. Textilkonzerválási problémák: tű, vagy ragasztó [Problems in textile conservation: needles or glue.]. *Figyelő*, 303-11.
- <sup>13</sup> Szederkényi, N., 1996. *A cébzászlók jellemzése, konzerválása és restaurálása* [The description, stabilization and conservation of guild flags]. Degree Thesis, The University of Visual Arts, Department of Conservation, Budapest, p. 17. Here I would like to say thank you and commemorate Ágnes Timár-Balázs who was the initial supervisor of my thesis, and then later kindly helped me with my work with her friendly advice and expertise.
- <sup>14</sup> *Regnál* is very flexible and lightfast. It resists animal and vegetal fats, oils, acids and alkalis. The dried coating can be melted at 90-100 degrees.
- <sup>15</sup> Timár-Balázs, Á., 1992. *Múzeumi textíliák mosása* [Washing historic textiles]. *Műtárgyvédelem* 21: 153-192.
- <sup>16</sup> I would like to say thank you to Györfi Mátéfy, who kindly offered his help with some problems that I had during conservation.
- <sup>17</sup> The composition of the elastic ground paste is: Bolognese chalk, triple mixture: 1 part Venetian turpentine + dammar dissolved in turpentine + 1 part linseed oil, coletta, honey.

Costumes are commonly known to be a fabric of interwoven symbols built one layer upon another. They express gender, age, social standing, and nationality through form, ornamentation, quality, and – most prominently – colour. In different times and places, some colours carried an identical message while the meaning of others changed diametrically. All shades of colour found a vividly descriptive role in Hungarian folk dress, with each detail filling in a blank on life journeys from the cradle to the grave.<sup>1</sup>

[ LILLA TOMPOS ]

## The symbolic meaning of red in seventeenth-century clothing

**A** centuries-old convention holds that emotions are expressed by white, red and black. Of course, the question arises as to whether or not the colour of a piece of cloth held any symbolic meaning within the complex system of symbols current in the seventeenth and eighteenth centuries, the period under examination. By no means can all the colours be addressed here, so red has been chosen for the purpose of the present study, as it appears most often and in the widest variety of shades and carries the most variegated symbolic messages. We aim to uncover the source of the symbols that became attached to the colour, and see how a reading of pieces of cloth in the aristocratic code of dress reflects colour symbolism. Given the scarcity of extant articles of clothing, we have also relied on written and illustrated sources, as well as the results of ethnographic scholarship<sup>2</sup> and Hungarian literature, which are rich with allusion to the subject. Chemical dye analysis will also be summoned as an aid in identifying the colours.<sup>3</sup>

Next to its name and material, inventories of estates, lists of clothes belonging to aristocrats and invoices will most often note the colour of a cloth. Inventories of various types of broadcloth kept in stock for military uniforms or servants' livery would sometimes be recorded by clerks on the basis of its colour. Not only does a vivid, colourful world unfold on perusal of these written records, but they also enable one to follow changes over the centuries. Red and its various shades, such as skin colour, carnation or garnet, were the clothing colours found most frequently in the sixteenth century, but people also wore blue, green, publican-colour (green), yellow, orange, purple-blue, blond and black. Silks were often enriched with gilt silver, or drawn silver wire called *scofium*. In such instances, one reads of a 'drawn gold' or 'drawn silver' textile, an allusion to the manner of preparation. A decided change in the use of colour in the wardrobes of Hungarian aristocracy took place in the first few years of the

seventeenth century. As the Spanish court style gained dominance along with adopted formalities and particular types of clothes such as the Spanish gown and the janker, the colour black also came into fashion. The two sorts of garment that appear in the records in huge numbers, the mantle and the cloak, were most likely worn on festive occasions, and were sewn from dark, frequently black, material.

Apart from the new emphasis on black, the names given to colours also changed. Terms compared the shades of colours to natural phenomena, plants or animals. In this way, colours could become more familiar to perception, and their clearer definition also became possible. To give a few examples, one can mention: hair colour – brown, sky or sea colour, wild saffron, ash, or pigeon colour, the colour of liver, peach blossom or turf. In some instances, finding the exact definition might cause the twenty-first-century reader some difficulty. Some colours where this might be the case are: pink, body colour or blush of dawn (Aurorafarb). Yet the plight of a husband going to market and being puzzled by the shopping list was not unknown in the seventeenth century, either. To illustrate this situation, we quote a letter of Tamás Nádasdy, in which he asks his wife, Orsolya Kanizsay, to define ‘lion colour’:

...and the scholar Balázs says that you would have silk of lion’s colour for the buttons, and some of a fine red, but we do not understand even the lion colour. So do write it down in a more obvious fashion, and send also some model, from which it can be told what kind of colours both are<sup>4</sup>

The colour palette brightens up in the second half of the seventeenth century and the terminology for the colours also goes through a change, as shown in the bills of the court tailors of Prince Pál Esterházy (1635-1713), written in German. Frequent variants in these are Näckher farb (bone colour), Perl farb (pearl colour), Zidronfarb (lemon colour), Bierfarb (beer colour), Veiglfarb (fig colour), along with the hues of flowers, the Apfelblie (apple bloom), Lauendl (lavender), Violet (violet), and Anzelin (gentian).<sup>5</sup>

The brightest among the shades of red in an everyday context was an orange hue mentioned in late seventeenth-century inventories as ‘coral colour’, the colour of red coral so popular in the embroideries and goldsmiths’ works of the age.<sup>6</sup> Skin colour was a red colour in the seventeenth century, as a poem by Péter Bornemissza makes clear. He imagined that the stones of heaven sparkled in a tone of red skin-colour as well as green and blue. This probably meant an orange shade of red, for which the other term for skin colour, nacracolour, referring to the painting technique, must have also been used.<sup>7</sup> We are led

to believe that both shades were identical with, or very similar to vermilion.<sup>8</sup> The colour of dawn is difficult to describe: while Romans saw the colour yellow in it, Bálint Balassi and Miklós Zrínyi sang about a beautiful red dawn. Prince Pál Esterházy had clothes made by the tailor from fine broadcloth, the colour of dawn (Aurorafarb), both for himself and the youths staying at the court.<sup>9</sup> They were aware of paler and darker hues of two popular flowers, the carnation and rose.<sup>10</sup> The royal colour was like scarlet, and there was also a flaming red,<sup>11</sup> and a darker hue found in cherry red, and a more bluish hue in purple.<sup>12</sup> The darkest among red colours with a tint of pink was crimson.<sup>13</sup>

All shades of red had exceptional status among the colours. Reds symbolized both positive and negative feelings: they might express love and passion; a crimson version symbolized wealth and power; while another shade represented nobility and bravery, but also the tragic death of a hero. Negative feelings and traits might also have been attached to certain shades. Judas is often a red-head in medieval paintings, and prostitutes have a bright red head of hair, while both Satan and a murderer were coloured the same in the visions of John the Evangelist.<sup>14</sup>

Hungarian folk tradition and folk verse hold that red is the colour of blood and fire, and magical properties were attributed to both. Red clothes later became the apparel for mourning as a result of this connection, replacing blood as man defended against harmful spirits with the blood of life. Folk beliefs said that a red ribbon, pearl or kerchief protected a pregnant woman or ill person from the evil eye, because they bore apotropaic magical powers.<sup>15</sup>

Though green represented new love in the culture of gallantry, the evidence of works of literary fiction and quotes taken from folk poetry, as well as artefacts in our possession go to prove that red was the colour of love in accord with Christian colour symbolism.<sup>16</sup> ‘Will you send a letter with a beautiful red stamp? Will red words of love cover it all over?’ Love and tokens of love were red in poetry, but poets would often even see the faces of their loves as red, comparing them to the colour of flowers, and to jewels and angels for that matter.<sup>17</sup> A red kerchief, or a red boot, or one that was sewn over in red were gifts of love, and also represented a pledge as sung by so many unknown poets. A skirt is more than a mere lover’s gift, it is a proposal, as shown by the lines of a folk-song:

The carrier sent me a message that said:  
Would my rose have cloth that’s red?  
I want no clothes of a colour red,  
And nor will I the carrier have.

In another song, red skirts are mentioned:  
Send me doom my dear Greek lord, for  
Never will I have a true lord,  
Would I've ever had a true lord,  
A red skirt for me he'd have bought.<sup>18</sup>

In seventeenth-century aristocratic tradition, the gift of a red skirt, whether royal, cherry, lace, embroidered, silk or velvet, was an engagement gift. The engagement gift Imre Thurzó gave his bride-to-be, Krisztina Nyáryi, was a carnation skirt bedecked in flowers and drawn in gold, along with the *bomeza* (a sleeved shirt braced with baleen [‘Fischbein’: whalebone] called ‘Wams’ in German), and the small shoes and gloves ornamented with pearls that went with it.<sup>19</sup> Pál Esterházy also gave his fiancé, Orsolya Esterházy, a diamond-studded pendant and a red skirt with gold ornamentation.<sup>20</sup> The more precious materials were stored in a secure place and the notable event would even be memorialized in estate inventories: the registrar of the estate left by Mihályné Majthényi Barbara Pakay, who died

around 1640, records a red velvet skirt that had been an engagement gift.<sup>21</sup> A register of Borbála Ostrosics’s belongings gives an insight into the manner of making the gift, when it speaks of a ‘skirt of royal colour that was borne after the lady’.<sup>22</sup> A similar event was described by János Nemes in his diary: ‘the bride’s gift was taken to her after the ball at four o’clock’, seventh in a row of gifts, he remarks ‘a velvet skirt of cherry colour with fine pearls, stones and rosettes, as well as silver lace: worked in a rather beautiful German way’.<sup>23</sup>

The premise that the crimson velvet skirt, sewn with gilt and genuine pearls, which belongs to the Museum of Applied Arts (Budapest) and was taken from the Esterházy treasury, had once been an engagement present is based on the sources quoted above.<sup>24</sup> (Figs. 1-2.) The embroidery is missing in many places, with mends and replacements that are twentieth-century work by a conservator. The piece of clothing was disassembled, so it is not possible to ascertain how deep the pleats had been. Embroidery



FIGURE 1 Red velvet skirt from the Esterházy Treasury (detail)

FIGURE 2 Red velvet skirt from the Esterházy Treasury (detail)



of a somewhat reserved character decorates the edges that close in front, harmonizing well with the bottom edge embroidery. The design on the corner piece differs from that on the edges, as clearly articulated in the contour reconstruction made by the conservator. Posies of flowers and single stems of flowers alternate symmetrically at about mid-height on the skirt. The posies are composed of acanthuses, open and closed pomegranates placed vertically one on top of the other with stalks bending outwards, with tulips, tendrils criss-crossing and leaves that imitate heart and spear-head shapes. Above these are stalks and leaves forming ogee arches that end in lilies. The flower stem next to the posy is rooted in a heart, and a tulip floats on a pointed stalk above the closed pomegranate canopied in tulips, leaves streaming

from it. A tulip growing from an acanthus blooms among crescent leaves in the front of the skirt, crowned by a closed pomegranate and an acanthus bending to each side with the tendrils. A posy of flowers with a vertical axis, and stalks bending in arches to either side, was a typical Renaissance motif, appearing frequently on Hungarian canvas embroideries, the so-called ‘genteel’ embroideries of the late Renaissance. A similar alignment of pomegranates on a vertical axis with tendrils bending to either side can be found on a bed cloth with the Thököly coat of arms, which was also acquired from the Esterházy treasury.<sup>25</sup> Tulips, pomegranates and carnations were the staple flora of the Renaissance art of embroidery. The skirt would have belonged to the wife of István Esterházy, Erzsébet Thurzó, who died in 1641.<sup>26</sup> The richly ornamented, embroidered piece of clothing was delivered, along with a number of other clothes, to Esterháza, for the ‘bright’ celebration of Miklós Esterházy, the feast of Esterháza. It is probable that its bodice was lost and the embroideries damaged at this point, because the register drawn up for its transportation in 1778 mentions the piece of clothing barren of its bodice, and embroideries damaged or unstitched.<sup>27</sup> An inventory made in 1858-59 holds that the red velvet skirt as well as the blue and brown velvet skirt is bridal wear.<sup>28</sup> A number of Esterházy family ladies were portrayed in festive attire similar to the velvet skirt with pearls, among the paintings housed in both old family galleries of the Austrian town Forchtenstein and Hungarian Pápa. The first wife of Pál Esterházy, Orsolya Esterházy, perhaps wore her mother Erzsébet Thurzó’s dress for her portrait. She wears a so-called ‘Hungarian bodice’ with a laced stomacher decorated with pearls, a puff-sleeved bodice striped with ribbons, and an apron.<sup>29</sup> Ferencné Esterházy née Kata Thököly had a similar costume. (Fig. 3) Éva Thököly, the second wife of Prince Pál Esterházy, also wore a red dress set with pearls for her portrait. Her lace-trimmed apron is transparent, and one can glimpse a trace of the pattern decorating the borders of the folds that meet in front of the dress.<sup>30</sup>

In 1662, an unknown painter portrayed Baroness Borbála Wesselényi along with her splendid engagement gifts, befitting her groom Prince Simon Kemény.<sup>31</sup> (Fig. 6) Her gala dress was composed of a scarlet red ‘Hungarian bodice’ with gilt lace decorating the front, and ribbons to lace up the front, along with a bright red skirt. Sleeves sewn from a diaphanous veil-like material are drawn over her baggy sleeves, which bear a decoration of pomegranate patterns running criss-cross all over it. She holds the symbol of her high birth, a pair of gloves sewn with gold and pearls in her right hand, while a rose alluding to love is held



FIGURE 3 Unknown Artist: Countess Ferenc Esterházy



in her left. She wears a Hungarian girl's head-dress with pearl and flower ornamentation upon her dark hair, while the décolletage of her dress is emphasized by a high-lobed collar with strings of pearls sewn on. A jewel assembled from a number of pieces sparkles upon her bosom, as a metaphor for the flames of love: a rosette shape encrusted with red and white rubies, and diamonds, called *másli* (a bow) in the language of the day, from which hangs a flaming heart shot through with an arrow and held in hands folded over one another. From the cuffs of the hands are hung chains formed from linked rosettes, upon which rides cupid, the messenger of love's goddess Venus, with wings extended and bow and arrow trained upon the heart of the intended victim.<sup>32</sup> (Fig. 6)

Not only young brides, but their grooms also often donned the colour of love, a shade of red,

on the occasion of their weddings: 'The archduke – Zsigmond Báthory – wore clothes of red velvet, and the archduchess of blue velvet for the festive ceremony.'<sup>33</sup> Though the bourgeoisie of the eastern part of Hungary preferred an array of blue hues (dark blue being the most popular), on the occasion of taking a wife, János Csatári received a red pair of trousers, a red mink fur hat and a hussar's green dolman lined with fur from the throats of foxes.<sup>34</sup>

The only crimson-coloured stain dolman of the Esterházy treasury must surely have been made for a similar occasion. Sumptuous decorations, the trimmings (guipure) of various gilt and silver threads, envelop the whole dolman. (Figs. 4-5) Its rich, baroque ornamentation is unique in terms of both the Hungarian and the European world of artefacts. The dolman fastens with enamelled hooks and eyes.



FIGURE 4 Red satin (atlas) dolman from the Esterházy Treasury



FIGURE 5 Red satin (atlas) dolman from the Esterházy Treasury (detail)



Figure 6. Unknown Artist: Countess Borbála Wesselényi

The system of symbols represented by the hooks and eyes refer to marriage, in a manner similar to the compositions of hearts, doves and hands one comes across in engagement rings, pendants and bracelets. The dolman has a decoration on each front side: hands with lace cuffs reach out of a heart with an ornamental flower stem, each holding half a heart. A white dove with golden wings and a red beak perches on the hand and heart, so that when the dolman is closed a whole heart is formed and the doves kiss. Recent expert opinion identified the garment as the wedding dolman of Palatine Miklós Esterházy, but consideration of its size and technical matters now associate it with the second marriage of Pál Esterházy.<sup>35</sup>

Due to its cost, the shade of red dye with a tint of crimson has been the symbol of the power of the church ever since antiquity. The evidence of the oft-quoted line ‘I’ll dress you in crimson and velvet

and garland of pearls’ from the Hungarian folk-song points to a wide awareness of this fact. The right to don red was at any rate reserved for nobility, while the royal colour symbolizing the royal coat of arms must have been the shade of light red used in the composition of the heraldic sign.

The lords in waiting wore the colours of the royal coat of arms on the occasion of Matthias I’s entry into Buda, according to the ambassador from Pfalz.<sup>36</sup> This shade of colour was known by the same name even in the seventeenth century, as János Kornis brought crimson satin material of ‘royal’ colours for Gábor Bethlen from Venice in 1627, and we find mention of a piece of cloth made from royal red as well as gilt and silver galloons in an inventory of Prince Pál Esterházy’s clothes. A register of weapons, military equipment and assorted objects in the packing case of baron János Esterházy, Vice-General of Győr, and his son Ferencz, records (after saddles and tents) a number of clothes by colour, but differentiates pedantically between various shade of red: 2. Royal colour, 3. Crimson, 4. Skin colour, 5. Cherry.<sup>37</sup> This colour definition occurs in the eighteenth century as well. The procession returning the sacred crown from Vienna to Budapest (1790) was met by a welcoming crowd dressed in Hungarian regalia. The procession toured significant cities of the country. The carriage carrying the crown and the army of bodyguards were met by the citizens of Nagyvárad on mounts with high caps covered in taffeta dyed in the royal colour and aigrette.<sup>38</sup>

The death symbolism of red gained force for two reasons. In a work written by the herald of Sicile Alfonz V of Aragon (1474–1516),<sup>39</sup> this is the colour of heroism and bravery, while a dark shade of red befits blood and death. Christian liturgy, however, used it as the colour of sacrifice. This is why it could be used during the burial ceremony of the four young Esterházy brothers who died heroic deaths at Vezekényi in 1652. Mauritz Lang made the copper engraving of the groups participating at the large-scale, grandiose event on the basis of an engraving by Hans Rudolf Miller.<sup>40</sup> The forty-one groups can be clearly distinguished on the basis of the explanatory inscriptions. A picture of the scene, painted at the beginning of the eighteenth century but based on an engraving, has been housed in the castle of Fraknó since then.

The message of the painting is affirmed by notes in the diary of Pál Esterházy: Though the time of the burials had come, and we raised the bodies on the twentieth martyr ... from the chapel in Sente, having them placed in the carts which had all as one been draped in red broadcloth that reached to the ground. The same was draped on the horses drawing the cart, and similarly the flags brought out at the funeral were all of red broadcloth.<sup>41</sup>

Following the horses caparisoned in red velvet emblazoned with the Esterházy family coat of arms were men with red flags bowed to the ground, after which they led the horse of Lászo Esterházy in a covering of red velvet. Mourners with torches in hand bore the coffins covered in red upon their shoulders. The church itself had been modified; its decorations were covered according to the Jesuit chronicle ‘everything had been dressed in red, in clean silk or gilt broadcloth’.<sup>42</sup>

The accepted norm in Transylvania is that the red coffin of a man with a family was covered in black or cherry-coloured velvet.<sup>43</sup> A description of the burial of György Lázár reinforces and adds to the above statement:

In the year of our Lord 1661, and the month of January ... After having returned to Saint Demeter in the evening, we brought the corpse of my poor brother-in-law, György Lázár to Gyulakuta. We covered the coffin in red velvet, nailing the coat of arms upon it, which had been prepared as a fitting upon red taffeta, and the preacher of Gyulakuta gave his sermon over the body. The coat-of-arms symbolising the deceased was painted upon red taffeta as well.

Not only the burial accessories appeared in red, but the bier was also decorated in the same colour; the deceased was taken to the bier in clothes of red; the four Esterházy brothers were dressed in red, and also the poet Miklós Zrínyi, who had died a violent death in 1664. Péter Apor mentions that those who died in battle were buried in red high caps of Pozsony, as a tradition accepted all over Transylvania.<sup>44</sup> János Kemény reminisces about the testament of Gábor Bethlen, in which he prescribes, that his mourning be held in red clothes, and burial be decorated by the same colour.<sup>45</sup> Imre Thurzó, who had died at the young age of twenty four, was also dressed in a red tunic.<sup>46</sup> The deceased had been pictured upon a burial flag dressed in red clothes, as we are informed by the letter of Pál Perényi to Kata Perényi, the widow of Simon Kemény. He requests his sister to order the flag from the painter, a crucifix with Mary and Joseph on one side, and Simon Kemény on his knees, and dressed in a skin-coloured robe in front of them.<sup>47</sup>

The enumeration clarifies that the colour red gained a new meaning in its funereal role, it could represent a heroic, sacrificial death, or the pomp befitting the deceased. Two lines of an eighteenth-century folk song express this with pithy simplicity:

My Lord is gone he's gone to battle, he's gone to battle  
And now I'll mourn him in purple, I'll mourn him in purple.<sup>48</sup>

## Endnotes

- Gáborján, Alice. *A színek jelentése a magyar népviseletben*. [The meaning of colours in Hungarian folk costumes] In: *Folklór, életrend, tudománytörténet. Tanulmányok Dömötör Tekla 70. születésnapjára*, [Studies in Folklore, life-style and scholarship in celebration of the 70<sup>th</sup> birthday of Tekla Dömötör] Budapest, 1984: 70-86. She draws her conclusions not only from comprehensive knowledge of the past, but also the immediate experience of the material object, as follows: two shades of white, the yellowish colour of flax and linen cloth are associated with old age, whitened fine textiles with wealth, youth and festivity, while green is paired with youth. In certain regions the colour set aside for the mourning of youths was also green. Red often marked youth, but could also stand for festivity or wealth though is also known to have connoted mourning. Another sign of particular age is red when combined with black, as in the headdress of brides. Black denoted mourning and old age, yet change in fashion dictated changes in its use.
- Further reading: Erdélyi, Zsuzsanna. Adatok a magyar népköltészet szímszimbolikájához. [Data for the symbolism of colour in Hungarian Folk poetry.] *Ethnographia* 1961. I. Közlemény: 173-99, II. Közlemény: 405-29, II. Közlemény: 571-95. Hereafter: Erdélyi 1961.
- The doctoral dissertation of Ágnes Timár-Balázs under the title of ‘Dye Analysis of Textiles in Museum Collections’ was written in 1986. Apart from a comprehensive history of dyes and written sources of colouring for textiles, the subject is the testing of dye samples from textiles in museums. These analyses provided some insight into the time and place of the textiles’ origin.
- Szerelmes Orsikám *A Nádasdyak és Szegedi Körös Gáspár levelezése*. [‘My Dearest Orsi’ – Correspondence between the Nádasdy family and Gáspár Szegedi Körös.] Budapest, 1988: 214.
- Tompos, Lilla. Az Esterházyak számadásai és textilszámlái a XVII. századból. [The accounts and invoices for textiles belonging to the Esterházy family from the 17<sup>th</sup> c.] Budapest, 2000: 20, 141-5, 150-6. Hereafter: Tompos 2000.
- Szádeczky, Béla. *Apafi Mihály fejedelem udvartartása* [Prince Mihály Apafi’s court]. Budapest, 1911: 615.
- ‘The city sparkles in the open with stones of brilliant colours, / Stones of green or purple-blue colour / Red skin-colour, ash, blue and columns of red skin-colour’ [Peter Bornemisza: A song about the city of God, the Heavens above 1567.] The shade of skin-colour was achieved by the use of nitric acid, by a method for which the term was ‘nacra’. Walter Endrei: *Patyolat és Posztó*. [Canvas and Cambric.] Budapest, 1989: 231; Canvas and silk were dyed ‘nacra’ colour in equal quantity, as shown by the invoices of the tailors working for the Esterházy court: *Näcrafarb*: 150, *Näcrafarb*: 163-4, Tompos 2000.
- The only source from 1621, and the rest dates to the 18<sup>th</sup> c. Means: red-coloured mineral, of Persian origin, adopted later in Greek, Latin, early French and by German around 1200. Mária Horváth: *Német elemek a 17. század magyar nyelvében*. [German elements in the Hungarian tongue of the 17<sup>th</sup> c.] Budapest, 1978: 52.
- A variety of red canvas was worn in the Esterházy court: crimson and aurora colour (Aurorafarb) was worn by young barons, pink by the pages of the younger lords, and aurora colour was worn by the Esterházy. Tompos: 2000: 20: 154.
- Pink appears in 1416 for the first time in written sources, and next in 1513. It means red, with its whitened signification coming to bear at the time of language reforms. [Lóránd Benkő chief editor: *The Hungarian Dictionary of Historical Etymology*.] Budapest, 1967, II: 453.

- 11 The first occurrence of the word scarlet as flaming-red (1395), scarlet fabric (1448), the colour scarlet (1688). This is a migrant word, found in all languages in the same form. It was originally meant to identify a sort of dye extracted from a purple snail. In Hungarian, it is used both as a noun and as an adjective. It arrived in Hungary by way of the Mediterranean trade. Benkő 1967: III: 553.
- 12 Crimson can be found in written sources since the Middle Ages, from 1458 onwards. It is a bright, red-colour dye, cloth or leather with a slight tint of blue. It is a migrant word that came into use in Europe, adopted from the Arabic word 'kirmizí' meaning crimson red, but the way it has spread is unclear. Benkő 1967: II: 384. Using various mordants, a variety of bluish and purplish tints of the colour red were achieved; the use of kermes on the following mordants gave these particular tints: claret-red on alum mordant, bright red in alum with urochrome, carmine on tartaric and alum mordants, and purple on chrome and iron mordants. After the 'discovery' of America, the use of a new material became regular in the dyeing of cloth. A type of insect called cochineal (*Dactylopius Coccus cacti*) found in Mexico, Central and South America was available as a 'purple louse' in the Antwerp market from 1640 onwards. Timár-Balázs, Ágnes. Identification of dyes used on the Hungarian Coronation Mantle. *Magyar királyok koronázási palástja*. [The Coronation Mantle of Hungarian Kings] Budapest, 2002: 52.
- 13 The word turned up for the first time as 'bibura'; Bybur (1264); it meant fine linen if used as a noun (1395); material of red colour (1508); crimson coloured cloth (1585), cloth of flaxen material (1641). The origin of the word is uncertain. Due to its being expensive, the word is often listed next to velvet. Benkő 1967: I: 295. The colour was extracted from the purple snail. The material is colourless when inside the gills of this salt-water snail but becomes a dye of crimson colour when exposed to sunlight. Due to the cost of the dye extracted from the purple snail, dyeing with kermes became widely accepted in the 15<sup>th</sup> c. By a 1467 papal ordinance, the cloaks of cardinals had to be dyed with kermes. Timár-Balázs 2002: 52.
- 14 Revelation (6:4): And there came another red horse, and it fell upon him who rode upon it to take away the peace of the earth, and to make men kill one another; and he was given a great sword.
- 15 Erdélyi 1961: II. Közlemény: 405.
- 16 Kirschbaum, Engelbert von. *Lexikon der Christlichen Ikonographie*. Rom-Freiburg-Basel-Wien II: 10.
- 17 Tinódi, Sebestyén. *The history of Lady Judit*.
- 18 Erdélyi 1961: II. Közlemény: 411.
- 19 Kubinyi, Mihály. *Thurzó Imre*. Budapest, 1888: 53.
- 20 Bubics, Zsigmond –Merényi, Lajos. *Herceg Esterházy Pál nádor 1635–1713*. Budapest, 1895: 105.
- 21 The estate of Barbara Pakay, wife of Mihály Majthényi around 1640. In: *Történelmi Tár* 1897, p.136.
- 22 Lukinich: Inventory of Bethlen Farkasné Ostrosics Borbála's movables. In: *Történelmi Tár* 1908, p.12.
- 23 Tóth, Ernő. The diary of János Nemes from the years 1651 to 86. In: *Történelmi Tár* 1902: 237.
- 24 Quote: Inv. No. 62, 69 Dark red warp velvet, with an applied padded embroidery of appliqué on a canvas base, filled, laid, and for which gilt silver thread was used, also decorated with mother of pearl along the contours and wire. White pearls are stitched on the leaves, and strewn across the larger surfaces. The embroidery is missing from the front right part, while only fragments remain of many of the pieces. Length: 1035 mm, width: 3500 mm.
- 25 László, Emőke. Magyar hímzett és selyemkárpitok a 16-17. századból. [Hungarian embroidered and silk carpets from 16<sup>th</sup>-17<sup>th</sup> c.] *Ars Decorativa-Iparművészet*, 1992: 61-105.
- 26 Mol. Rep. 12. Fasc. Q. 633
- 27 The costume is recorded as having belonged to the treasury of Pál Esterházy in 1696, and the records from 1778 show: 'Ein roth Sammeneter Frauen Rock mit Gold und Perlen gestickt ohne Mieder. NB die Perlen sind von zwey Blettern abgetrennt worden'.
- 28 *Ein Kirschrothsamtenner Brautrock mit Gold gestickt*.
- 29 *Old Hungarian portraits*. An exhibition in Tata curated by, and catalogue compiled by Enikő Buzási: 1988. Cat. no. 12.
- 30 *Ancestral Galleries and Family Portraits from Aristocrats*. An exhibition curated by, and catalogue compiled by Enikő Buzási. Cat. No.: Plate. C. 30.63; Plate C. 36.72.
- 31 Borbála Wesselény (1648–1662) was the bride of Simon Kemény I, son of her stepfather, János Kemény prince of Transylvania. The painting portrays the young bride shortly before her tragic death.
- 32 Szilágyi, András. Az Esterházy-gyűjtemény Cupidós násfájáról. [About the cupid pendant from the Esterházy collection.] *Ars Decorativa-Iparművészet* 13. Budapest, 1993: 145-58.
- 33 The wedding took place on the 6<sup>th</sup> of August. The Prince donned red velvet clothes for the festive ceremony, while the Princess wore blue velvet. Szádeczky, Lajos. *Báthory Zsigmondné*. I. In: Századok. 1883: 57.
- 34 Zoltai, Lajos. A debreceni viselet a XVI-XVIII. Században. [Fashionable wear in Debrecen from the 16<sup>th</sup> to the 18<sup>th</sup> c.] *Ethnographia, Népelet* 1938: 96.
- 35 Fellows of the Museum of Applied Arts Budapest undertook their survey of the artefacts from the Esterházy collection, now part of the Museum's collection. The author summarized the results of the research in her doctoral dissertation in 1994: Costumes of the Esterházy family. The material, cut and decoration of Hungarian aristocratic costumes from the 16<sup>th</sup> to the 18<sup>th</sup> c. Twenty-five pieces of cloth have come down to us from the 16<sup>th</sup> and 17<sup>th</sup> c. The 21 pieces of costume from the Esterházy treasury are held in the collection of the Museum of Applied Arts, Budapest, while the dolman from the Bánffy treasury, and the rest of the pieces cared for by the Church as sacred objects have been placed in the care of the Hungarian National Museum. The Esterházy Palace situated in the Buda Castle was damaged by a bomb in the Second World War, and the treasures hidden in its cellar suffered damage from remaining there over the years that followed. Some of the textiles lost their original colour during this time, and became brown, while others stained each other. The 25 pieces were made of a variety of materials, which can be listed as follows: coloured floral Turkish silk (1), woven with gold (5), light green (1), dark green (1), purple (1), brownish-green (1), black (2). Dark-blue (1), a dark blue cloth that had worn away (3), while the remaining 9 pieces of cloth had been made in shades of red. Five of these had kept their original colour, four had changed to a brownish-yellow colour. To determine the original colours of the cloth and the type of dye used, a dye analysis had to be carried out. The analysis was indispensable to find out which pieces were being treated and their names in the inventories, while it also supported an exact dating of items. The dye analysis was conducted by Ágnes Timár-Balázs: the 16<sup>th</sup>-c. dolman faded to a yellow colour (Inv. No.: 52.2682) was mentioned as cherry red in the 19<sup>th</sup> c., and salmon red in the 20<sup>th</sup> c. The textile dye used is madder (*Rubia tinctoria*), known in antiquity, while the red damask strip sewn onto its lining has the dyestuff cochineal. This dye provides dating evidence: the dyed cloth cannot be earlier than the 16<sup>th</sup> c., since the dye extracted from the American insect was not used by European dye workshops before that date. The caftan attributed to János Sobieski (Inv. No. 52.2768) has faded to a yellowish colour; it had once been dyed with madder (*Rubia tinctorum*). The inventory from 1725 mentions it

as a skin-coloured garment. The dolman, now faded to a brownish colour, was originally light red in hue (Inv. No. 52,2379); its dyestuff is no longer detectable. Inventories record a skin colour in 1725, vermilion in 1858, and the custodial contract of 1923 describes it as brick red. The short, fur-lined coat (Inv. No. 52,2773) was seen as red in the inventory of 1722, and skin-coloured in 1725. The chain-mail shirt has kept its crimson colour (Inv. No. 52,2370). The groom's dolman was dyed with (Inv. No. 52,2804) *cozenil* (*coccus cacti*). The dye used for the red velvet dolman was not analysed. (Inv. No. 52,2377). The stock keeper of 1641 saw the skirt (Inv. No. 62.69) as bright red, another one saw it as red in 1766, and a cherry red colour was attributed to it in 1858. The dolman of a member of the Bánffy family is flesh-coloured; analysis of its dye has not yet taken place. (Inv. No.: 1954.666).

- 36 Csánki, Dezső. I. Mátyás udvara. [The court of Matthias the 1<sup>st</sup>] *Századok*. Budapest, 1883. XVII: 60.
- 37 Purchases made by Gábor Bethlen between 1615 ad 1627. In: Radvánszky, Béla.  *Holding Court and inventories*. Budapest 1888. I: 105. Red in the clothing inventory of Prince Pal Esterhazy: *Royal red coloured cloth with gilt silver cords* [Thaly, Kaman. A register of weapons, military equipment and assorted objects belonging in the packing case of Baron Janis Esterházy, Vice-General of Győr, and his son Ferencz (1700–1704)] In: *Történelmi Tár* 1886: 181-95. The description details saddles and tents but mentions only the colour of the clothes: 1. Black, 2. Royal colour, 3. Crimson, 4. Skin colour, 5. Cherry, 6. Violet, 7. Orange, 8. Apricot-bloom, 9. Poppy, 10. White, 11. Yellow, 12. Sky-colour, 13. Publican-colours, 14. Colour of grass, 15. Dark green.
- 38 Tompos, Lilla. Egy történelmi esemény tükröződése a viseletben. [Reflection of a historical event in the costumes worn] *Folia Historica* XXI, 1998–1999. 2000: 217.
- 39 Linthicum, M. Channing: *Costume in the Drama of Shakespeare and his Contemporaries*. Oxford, 1936: 13-51. Costume Colours in the Drama. The study brings up examples from works by Benjamin Johnson (1572–1637), Thomas Middleton (1570–1627) and John Ford (1586–1639). It details the use of colours as follows: (1) how colours are brought into play in English drama; (2) the colours mentioned; (3) the meaning of these colours in the plays at the time they were written.
- 40 *The songs of Gyarmati Bálint Balassi*. Budapest, 1986: 103. Text and melodies edited, with annotations by: Péter Kőszeghy and Géza Szabó.
- 41 Galavics, Géza. *Kössünk kardot az pogány ellen. Török háborúk és képzőművészet*. [Let us draw our swords against the heathen. The Turkish Wars and the Fine Arts.] Budapest, 1986. 80, Plate 126: 38, p.91.
- 42 Further reading on aristocratic funeral services: Péter Szabó: *A végtisztesség*. [Last Rites] Budapest, 1989: 26.
- 43 Szabó 1989: 38, 41, 45.
- 44 Apor, Péter. *Metamorphosis Transylvaniae*. Bucharest, 1978: 124.
- 45 Szabó 1989: 59-60.
- 46 Kubinyi, Mihály. *Thurzó Imre*. Budapest, 1988: 31.
- 47 Kemény-Archives: Perényi Pál levele Kemény Simon özvegyéhez. [The letter of Pál Perényi to the widow of Simon Kemény] *Történelmi Tár* 1871: 18, 173.
- 48 Harsányi, István. *Két XVII: századi dalgyűjtemény*. [Two collections of songs from the 18<sup>th</sup> c.] *Ethnographia*, 1913: 364, song no. 33.

# Bibliography

Ágnes Timár-Balázs

## Abbreviations

---

ICOM CC = ICOM Conservation Committee

ICOM CC WGT = Working Group on Textiles

ICOM CC WGTR = Working Group on the Training of Restorers

MH = Museum Newsletter [in Hungary]

MK = Museum Studies [in Hungary]

MKF – IRT = Institute of Restorer Training, Object Restoration Faculty of the Hungarian Academy of Fine Arts

MM = Hungarian Museums

MMt = Protection of Museum Objects [in Hungary]

MRMK-T = Institute of Conservation and Methodology of Museums [in Hungary]

NRSZ = International Restorer Seminar– Veszprém, Hungary

1974. 1. – Az általános restaurátorműhelyek állapotával kapcsolatos felmérés eredményei. [Experience gained from the survey of the state of general conservation workshops] In: MRMK -T, Budapest, 1974/1: 45-9.
1975. 2. – Múzeumi textíliák színezékének azonosítása vékonyréteg kromatográfiával. Egyetemi szakdolgozat. [Investigation of dyes on museum textiles. Thesis for university degree] Budapesti Műszaki Egyetem -Technical University, Budapest, 163 p.
3. – Bevezetés a szerves kémiába. [Introduction to organic chemistry] In: MKF– IRT, Budapest, p. 306.
1976. 4. – Felületaktív anyagok. [Surface active agents] In: MMt, 1976/3: 189-211.
5. – Régi textíliák színezékeinek analízise. [Analysis of colouring matters of old textiles] In: In: MRMK-T, 1976/3: 194-203.
6. – Textíliák dublázása. [Doubling of textiles] In: MMt, 1980/7: 113-21.
7. – Felületaktív anyagok a textilrestaurálásban. [Adhesive techniques in textile conservation] In: MMt, 1967/3: 189-211.
1978. 8. – Munkavédelem a restaurátorműhelyekben. [Health and safety in conservation workshops] MKF-IRT, 35 p.
9. – Műanyagok a műtárgyvédlemben. [Synthetic Polymers in Conservation] MKF-IRT, 135 p.
1979. 10. – A műtárgyvédelmi szakfelügyelet 1979. évi tapasztalatai. [Experiences of supervision of art object protection in the year 1979] In: MRMK -T, 1979/6: 25-8.
1980. 11. – Múzeumi környezet Hollandiában. [Museum environment in The Netherlands] In: MK, 1980/1: 74-6.

12. – with Morgós, András : Útibeszámoló az MRMK Restaurátor Osztályának 1980. májusában az NDK-ban tett tanulmányútajáról. [Report on the study tour of the Restorer Department of the MRMK in the German Democratic Republic, May 1980] In: MMt, 1980/7: 192-5.
13. – Ösztöndíjjal Hollandiában. [With a scholarship in The Netherlands] In: MMt, 1980/7: 146-58.
1981. 14. – A textilszínezés története c. fejezet. [History of textile coloration] In: Textilkészítéstechnika. MKF-IRT: 117-209.
15. – Műanyagok használata a múzeumi műtárgyak restaurálásában. [Synthetic polymers in conservation] In: Műanyag és gumi, 18. évf. 2.sz. 1981: 33-7.
16. – Ki a felelős: a muzeológus vagy a restaurátor? [Who is responsible: the curator or the restorer?] In: MK, 1981/2: 52-6.
17. – Medium level course for textile restorers in Hungary. In: Preprints of the 6th Triennial Meeting of the ICOM CC, Ottawa, 1981:7.
18. – Tanulmányúton Ottawában. [Study Tour in Ottawa] In: MK, 1981/2: 113-8.
19. – with Nagy, Katalin: Textilkészítés története és alapfogalmak. [Technology of textiles. History and introduction] Bp.1981. MK-IRT, 266 p.
1982. 20. – Történeti textíliák színezékeinek vizsgálata [Investigation of dyeing historical textiles]. In: 3.NRSZ, Veszprém, július 11-20. 1981. Budapest, 1982: 134-6.
21. – Beszámoló az ICOM WGTR 1983. szeptemberében, Drezdában tartott konferenciájáról. [Report on the Dresden Conference of ICOM WGTR in September 1983. ] In: MMt, 1982/10: 359-62.
22. – with László Emőke, Lakiné Tóth Ilona: Viseletek, Történet és restaurálás. [Costumes: history and conservation] In: MKF-IRT, Budapest, 1982. 241 p.
1983. 23. – Színezékek és színezési eljárások vizsgálata a hagyományos népi textilszínezés területén. [Investigation of dyes and dyeing methods in the traditions of Hungarian folk dyeing] With Szendrői Júlia; Zoborné dr. Frankl, Judit, In: Magyar Textiltechnika, XXXVI. évf. 10. 1983: 505-8.
24. – Egy konferencia tanulságai. [Results of a conference] In: MK, 1983/1: 105-7.
25. – Hagyományok a magyar népi textilszínezésben. [Traditions of Hungarian folk dyeing] With Szendrői, Júlia; Zoborné dr. Frankl Judit. In: Magyar Textiltechnika, XXXVI/1.1983: 570-4.
26. – Az anyagvizsgálatok eredményeinek felhasználása a textilrestaurálásban. [The role of the material test in textile conservation] In: 4th NRSZ, Veszprém, 1983: 229-40. 1984.
27. – The teaching of organic chemistry and chemistry of plastics at the MKF-IRT. In: 7th Triennial Meeting of the ICOM CC, Copenhagen, 1984: 842120-842122
28. – Az anyagvizsgálatok eredményének felhasználása a textilrestaurálásban. [The role of material tests in textile restoration] In: MMt, 1983/12. Budapest, 1984: 231-42.
29. – Múzeumi textíliák raktározása. [Storage of museum textiles] In: MMt, 1984/13: 203-22. 1985.
30. – with Frankl, Judit. and Rusznák István: Színüket veszített múzeumi textíliák színezékvizsgálata. [Investigation of dyes on colourless archaeological or faded textiles] In: A XX. Magyar Kolorisztikai Konferencia előadásai, Budapest, 1985: 15-8.
1986. 31. – Ideas to assist restorers in learning organic chemistry and chemistry of plastic. In: Postprints of the Interim Meeting of the ICOM CC for WGTR, London, 1986. 12 p.
32. – Múzeumi textíliák színezékvizsgálata. Egyetemi doktori értekezés. [Investigation of coloration of historical textiles. Doctoral dissertation] Budapesti Műszaki Egyetem, 1986. 163 p.

1987. 33. – Investigation of dyes on Hungarian folk textiles. In: Preprints of the 8th Triennial Meeting of the ICOM CC, Sydney, 1987: 421-6.
34. – Színüket veszett történeti textíliák színezékvizsgálata. [Investigation of coloration of historical textiles] In: Kolorisztikai Értesítő, 1987/2-3: 61-70.
35. – with M. Járó, L. Kriston: X-Ray diffraction investigation of the pigments of printed textiles. In: Preprints of the 8th Triennial Meeting of the ICOM CC, Sydney, 1987: 37-40.
36. – with Roelofs, Wilma: Identification of the dyes on the Hungarian coronation mantle. In: Textile History, 1987/18: 87-96.
1988. 37. – Investigation of dyes on textiles from the collections of Hungarian museums. In: Archaeometrical Research in Hungary, 1988: 231-48.
1989. 38. – A különböző kémiai beavatkozások károsító hatása a rostokra. [Deterioration process of fibres in different chemical actions] In: 7th NRSZ , Veszprém, Hungary, 1-10. July 1989: 77-82.
1991. 39. – A tárgyrestaurátorok egyetemi képzéséről. [On the university education of object restorers] In: MH, XII. évf. 9.sz. 1991: 18-21.
40. – Synthetische Doublierstoffe in der Textilkonservierung. [Synthetic polymers in textile conservation] In: Restauratorenblätter, 1991: 95-113.
41. – A Hampton Court-i konyhák. [Kitchens in Hampton Court] In: MH, XII. évf. 11.sz. 1991: 19-20.
42. – Új ismeretek a Hampton Court-i kastélyról a tűzkár nyomán. [New experiences on the Hampton Court castle after damage by fire] In: MH, XII.évf. 11. sz. 1991: 18-19.
43. – Tanácsok a vizsgamunka diplomamunka megírásához. [Advice on how to write the examination and diploma works] In: MKFIRT, 1991: 7.
44. – Szintetikus polimerek a textildublizálásban és megerősítésben. [Synthetic polymers in adhesive treatments of textiles] In: MMt, 1991/20: 79 -111.
45. – 'Textiles Conservation Science' Summer School Budapest, 10-21. June 1991. See also: Newsletter WGT, 1991/2: 6-7.
46. – Karen Finch in Australia. In: Newsletter ICOM CC WGT, 1991/2-3. p. 4.
1992. 47. – Bogarasak vagyunk. [We are faddy] In: MH, XIII.évf. 7-8.sz. 1992: 208.
48. – Assessment of practical ability of applicants to the faculty for MKF-IRT. In: Postprints of the Interim Meeting of the ICOM CC WGTR, London, 1992: 3.
49. – with Szőke, Ágnes: The 'original' colour scheme of the embroidered cushions from Hódmezővásárhely. In: Dyes in History and Archaeology, 10th Meeting, 1992: 42-7.
50. – Már az ókorban is óvták az értékes tárgyakat. A múzeumi műtárgyak konzerválásának és restaurálásának története. [In ancient times, valuable objects were already protected] In: Magyar Nemzet, 1992. október 29: 10.
51. – Szerves kémiai alapismeretek. [Basic knowledge of organic chemistry] In: A könyv és papírrestaurátor tanfolyam jegyzetei, Országos Széchényi Könyvtár, 1992: 28.
52. – Messages of the coordinator. In Newsletter ICOM CC WGT, 1992/1: 1-2.
53. – Tenth Annual Meeting on Dyes in History and Archaeology. National Gallery, London, 13th September 1991. In: Newsletter ICOM CC WGT 1992/1: 4.
54. – Paper and textiles: The Common Ground. Glasgow, 19-20 September, 1991. In: Newsletter ICOM CC WGT, 1992/1: 5-6.
55. – On the base of materials sent by David Howell, Chairman of the Committee of Wet Cleaning Research. In: Newsletter ICOM CC WGT, 1992/1: 11-12.
56. – Research on solvents and solutions for stain removal on cotton, linen, wool and silk. In: Newsletter ICOM CC WGT, 1992/1: 12.
57. – Múzeumi textíliák mosása. [Washing historical textiles] In: MMt, 1992/21: 153-92.
58. – Megmérettünk és középsúlyúnak találtattunk. ['Though are weighed in the scales'- and found middle weight]. In: MH, XIII. évf. 5. sz. 1992: 126-9.
59. – Messages of the coordinator. In: Newsletter ICOM CC WGTR, 1992/2: 1-2.
60. – Tanárként Afrikában. [As a teacher in Africa] In: MH, XIII. évf. 2.sz. 1992: 37-9.



1993. 61. – Messages of the coordinator. In: Newsletter ICOM CC WGT, 1993/1: 1-2.
62. – with Mátéfy, Gysrk – Csányi, Sándor: Effect of stains and stain removal on historical textiles. In: Preprints of the 10th Triennial Meeting of the ICOM CC, Washington D.C. 1993: 330-5.
63. – Messages of the coordinator. In: Newsletter ICOM CC WGT, 1993/2: 1-5.
64. – Műtárgyak szerves anyagainak felépítése és lebomlása. Tankönyv. [Structure and deterioration of organic materials of museum objects. Textbook.] Budapest, 1993. 280 p.
65. – Az ICOM Konzerválási Bizottsága 10. Triennáléja. [Tenth triennial meeting of the ICOM CC] In: MH, XIV. évf. 10.sz. 1993: 262-3.
66. – Scientific principles of textile conservation. Budapest, 1994 July 3-23. In: Newsletter ICOM CC WGT, 1993/2: 18.
67. – Műtárgyak szerves anyagainak felépítése és lebomlása. [Structure and deterioration of organic materials of museum objects] In: MMt, 1993/22: 277.
1994. 68. – Messages of the coordinator. In: Newsletter ICOM CC WGT, 1994/1: 1.
69. – The coordinator in Sweden and Denmark. In: Newsletter ICOM CC WGT, 1994/1: 8-9.
70. – Messages of the coordinator. In: Newsletter ICOM CC WGT, 1994/2: 1-2.
71. – So many countries, so many costumes: different approaches to textile conservation. Conference of the ICOM CC WGT, 11 to 15 September 1995. Hungary, In: Newsletter ICOM CC WGT, 1994/2. 14 p.
72. – Spontán és nem spontán reakciók, avagy analógia restaurátorképzésre. [Spontaneous or non-spontaneous reactions – analogies in the training of restorers ] In: MH, XV. évf. 1.sz. p. 43-6.
73. – Nemzetközi textilrestaurátor tanfolyam Budapesten. [International Textile Restorer Course in Budapest] In: MH, XV. évf. 10.sz. 1994: 279.
74. – 20 éves a levelező tagozatos egyetemi restaurátor-képzés. [20 years of university restorer education] In: MH, XV. évf. 3.sz. 1994: 70-2.
- 74/a – Hungary: twentieth anniversary of the academic training of object conservators. In: Newsletter ICOM CC WGTR, No. 10/1994: 7-8.
75. – A műemlékteremtés nigériai módja, a MOTNA. [Nigerian ways to build new monuments: the MOTNA] In: MMt, 1993/22. Budapest, 1994: 245-6.
76. – Kéziratok, nyomtatványok és grafikák író- és festékanyagai : összetételük, készítésük, vizsgálatuk, károsodásuk, rögzítésük. A grafikai technikák felismerésének alapjai. [Writing and colour stuff of manuscripts, printed materials and graphics. Components, test damages and fixing. Basics of recognition of printing techniques.] (With Kastaly Beatrix; Albrechtne Kunszeri Gabriella; B. Kozocsa Ildikó; Izsó Mária; Járó Márta; Gajdó Gyula; and Pankaszi István) Országos Széchényi Könyvtár, 1994. 56 p.
77. – Magyarország az ICCROM 87. tagállama. [Hungary is the 87th Member State of ICCROM] In: MH. XV. évf. 1.sz. 1994: 19-21.
78. – Makisi tánckosztüm, és a boszorkányorvos eszközei, avagy kell-e kémia az afrikai restaurátornak? [Makishi dancing costumes and tools of witchdoctors or: do African restorers need chemistry?] In: MMt, 1993/22. Budapest, 1994: 239-44.
79. – Káros anyagok a műtárgy környezetében. [Harmful materials in the environment of the art object] In: MMt, 1994/23: 13-28.
1995. 80. – Komplexképzők a festett műtárgyak tisztításában. [Sequestering agents in the cleaning of painted objects] In: MMt, 1994/23. Budapest, 1995: 29-38.
81. – Safeguarding Science. In: Hali 81, 1995. 81 p.
82. – Message of the coordinator. In: Newsletter ICOM CC WGT, 1995/1: 1-2.
83. – Message of the coordinator. In: Newsletter ICOM CC WGT, 1995/2: 1-2.
84. – A Német ICOM Nemzeti Bizottság vendégül látta a weimari csoport delegáltjait. [The German National Committee of ICOM hosted the delegation of the group of Weimar] 1995. szeptember 9-13., In: MM, 1995/2: 52-3.
85. – A stitch in time saves nine – ethical aspects of textile conservation. In: Yearbook of the Textilmuseum, Budapest, 8. Special Issue, 1995: 60-75.

86. – Where is the border between different ‘levels’ in the training of conservators? In: Postprints of the Interim Meeting of the ICOM CC WGTR, Rolduc, 1995: 7.
87. – Az ICOM CC WGT konferenciája Magyarországon. [Interim meeting. International Conference of the ICOM CC WGT. Budapest, Hungary, 11-15. September 1995.] In: MH, XVI. évf. 11. sz., 1995: 323-5. 1996.
1996. 88. – “Tell me and I hear it, show me and I see it, let me do it and I learn it” – (Confucius). In: Muzeoforum, Zveza Muzejev Slovenie, 1995/96: 41-54.
89. – Message of the coordinator. In: Newsletter ICOM CC WGT, 1996/1: 1-2.
90. – Defining different level in the training of conservators: an example from Hungary. In: A qualified community: towards internationally agreed standards of qualification for conservation, ICOM CC, 1996: 19-22.
91. – “Szégyen és büszkeség”. [Shame and pride] In: MM, 1996/4: 57-8.
92. – Régészeti leletek konzerválásának alapjai. [Translation of Janey M. Cronyn: The elements of archaeological conservation. 1990. Rutledge, London.] Magyar Nemzeti Múzeum, 1996. 280 p.
93. – Interim Meeting. International Conference of the ICOM CC WGT. Budapest, Hungary, 11-15. Sept. In: Newsletter ICOM CC WGT, 1996/2: 2-5.
94. – A múzeumi tárgyrestaurátorok képzése Magyarországon. [Training of Hungarian object conservators] In: MM, 1996/3: 47-52.
95. – Dr. Harold Plenderleith ünneplése. [Celebrating Dr Harold Plenderleith’s birthday] In: MM, 1996/1: 54-5.
96. – with Szőke Á.: Kísérlet a hódmezővásárhelyi szőrös párnavégek színvilágának meghatározására. [Experiment with the definition of the colours of a furry pillon extremity found in Hódmezővásárhely] In: A Móra Ferenc Múzeum Évkönyve. Studia Ethnographicae, 1995: 251-9.
1997. 97. – Báthy, Géza– Velledits, Lajos: A restaurálás története és etikája. [History and ethics of restoration] Restaurátorképzés jegyzetei, Budapest, 1997: 1-30.
98. – Raphael-program. [Raphael Program] In: MH, XVIII. évf. 4.sz. 1997: 106.
99. – Megmentett műkincsek c. kiállítás vezetője. [Restored treasures catalogue] 1997. 8 p. 1998. 10 p.
100. – Az ICCROM-ról. [ICCROM] In: MM, 1997/4: 52-5.
101. – Kapcsolat a természettudományok és a restaurálás között. [The interface between science and conservation] In: MM, 1997/2: 39-42, 99.
102. – Hogyan választják az ICCROM igazgatóját? [How to elect the ICCROM director?] In: MH, XVIII. évf. 4.sz. 1997: 105-6.
103. – Restaurátorok remekei ’96. In: Magyar Iparművészet, 1997/2: 76-7.
104. – Megmentett műkincsek ’97. [Restored treasures ’97] In: MM, 1997/3: 39-42.
105. – A múzeumi tárgyrestaurátorok egyetemi képzése Magyarországon. [Training of Hungarian object conservators] In: Magyar Restaurátorkamara, 1997: 59-63.
106. – Irányzatok a textilrestaurálásban a 20. század végén. [Tendencies of textile conservation at the end of the 20th century] In: MMt, 1997/26: 117-26.
1998. 107. – Textile and leather diploma works at the MKF-IRT. In: Textile Newsletter ICOM WGT, 1998.1. 30.
108. – with Dinah Eastop (eds.): International perspectives on textile conversation. Archetype, 1998. 169 p.
109. – A görögországi Athéni Technikai Főiskolán tartott összejövetel és konferencia. [Conference in Athens] In: MH, XIX. évf. 6.sz. 1998. 157 p.
110. – Megmentett műkincsek ’98. Kiállítás az Iparművészeti Múzeumban. [Restored Treasures ’98-Exhibition in the Applied Arts Museum] In: MM, 1998/3: 45-6.
111. – Training textile conservators in Hungary: methods for teaching ethics. In: International perspectives on textile conservation, 1998: 81-3.
112. – History of dye investigation on historical textiles. In: A Textilmúzeum Évkönyve, 1998. 12 p.
113. – Az ICCROM meghirdeti a “Csoportmunka a műtárgyak megóvásában” című európai programja II. fázisát. [II. phase declared by ICCROM: Teamwork to protect art works] In: MH, XIX. évf. 3.sz. 1998: 69-71.

1999. 114. – with Dinah Eastop: Chemical principles of textile conservation. Butterworths–Heinemann, 1998, 444 p.
115. – Beszámoló az ICOM CC vezetőségének 1998. 11. 12-14. között Budapesten tartott üléséről. [Report on the session of ICOM CC, Budapest, 12-14. 11. 1998.] In: MH, XX. évf. 2.sz. 1999: 49-50.
116. – 25 éves az egyetemi tárgyrestaurátor– képzés [25-year anniversary of the MA degree training program of Hungarian object restorers] Magyar Nemzeti Múzeum, 1999: 20.
117. – Drying behaviour of fibres. In: Preprints of the 12th Triennial Meeting of the ICOM CC, Lyon, 1999: 661-6.
118. – ‘Job description – definition?’. In: CURRIC, Preprints of the International Seminar on University Postgraduate Curricula for Scientists, Bologna, 26-27. November 1999. 5 p.
119. – Muzeológus szemmel a lisszaboni EXPO ’98 portugál pavilonjában. [Curatorial aspects in the Portugal pavilion of EXPO ’98] In: MM, 1999/1: 51-2.
120. – Artefacts, conservation and sciences. In: Conference on public collections and science, Budapest, 1-2. July 1999: 8.
121. – Éri István köszöntése. [Salute to István Éri ] In: MM, 1999/2: 17-9.
122. – Máthé, György: A műtárgyvédelem és a restaurálás szervezése a múzeumokban. Kézikönyv muzeológusoknak és restaurátoroknak. [Translation of Susanne Keene: Managing conservation in museums. 1996. Butterworth-Heinemann, London] Magyar Nemzeti Múzeum, Budapest, 1999. 233 p.
2000. 123. – From test tubes to 3-D fluorescence spectrums. In: Object lessons in historic textile and costume research, 2000: 143-8.
124. – ICCROM, 2000. április 5-7. Róma, XXI. Közgyűlés. [ICCROM XXI General Assembly] In: MH, XXI. évf. 6.sz. 196 p.
125. – Mi fán terem a 'vegyész-restaurátor'. [What kind of job is the conservation scientist?] In: MM, 2000/1: 53-4.
126. – ‘Wet cleaning of historical textiles: surfactants and other wash bath additives’. In: Reviews in conservation, 2000: 46-64.
2001. 127. – Diploma works and their role in advocacy for conservation/restoration. In: Conservation around the millennium, Budapest, 2001: 145-50.
128. – Műtárgyak szerves anyagainak felépítése és lebomlása. [Structure and deterioration of organic materials of art works. 1] In: Műtárgyvédelmi szöveggyűjtemény, Museologica Carpathica, Miskolc, 2001: 122-80.
129. – A XXVI. Országos Restaurátor Konferenciához kapcsolódó rendezvény a restaurátorok nemzetközi kapcsolatairól. [The international contacts of restorers] In: MH, XXII. évf. 4.sz. 2001: 128-9.
130. – with Dinah Eastop, Materiais de Armazenamento e exposição. [Storage and display materials] In: Conservação: Conceitos e Práticas. [Conservation: concepts and practices] Universidade Federal de Rio de Janeiro, 2001: 141-84.
2002. 131. – A Magyar koronázási palást színezékének azonosítása. [Investigation of the dyes on the Hungarian coronation mantle. (Compilation)] In: Nagy E.K.: A magyar királyok koronázó palástja, Veszprém-Budapest, 2002: 49-54.

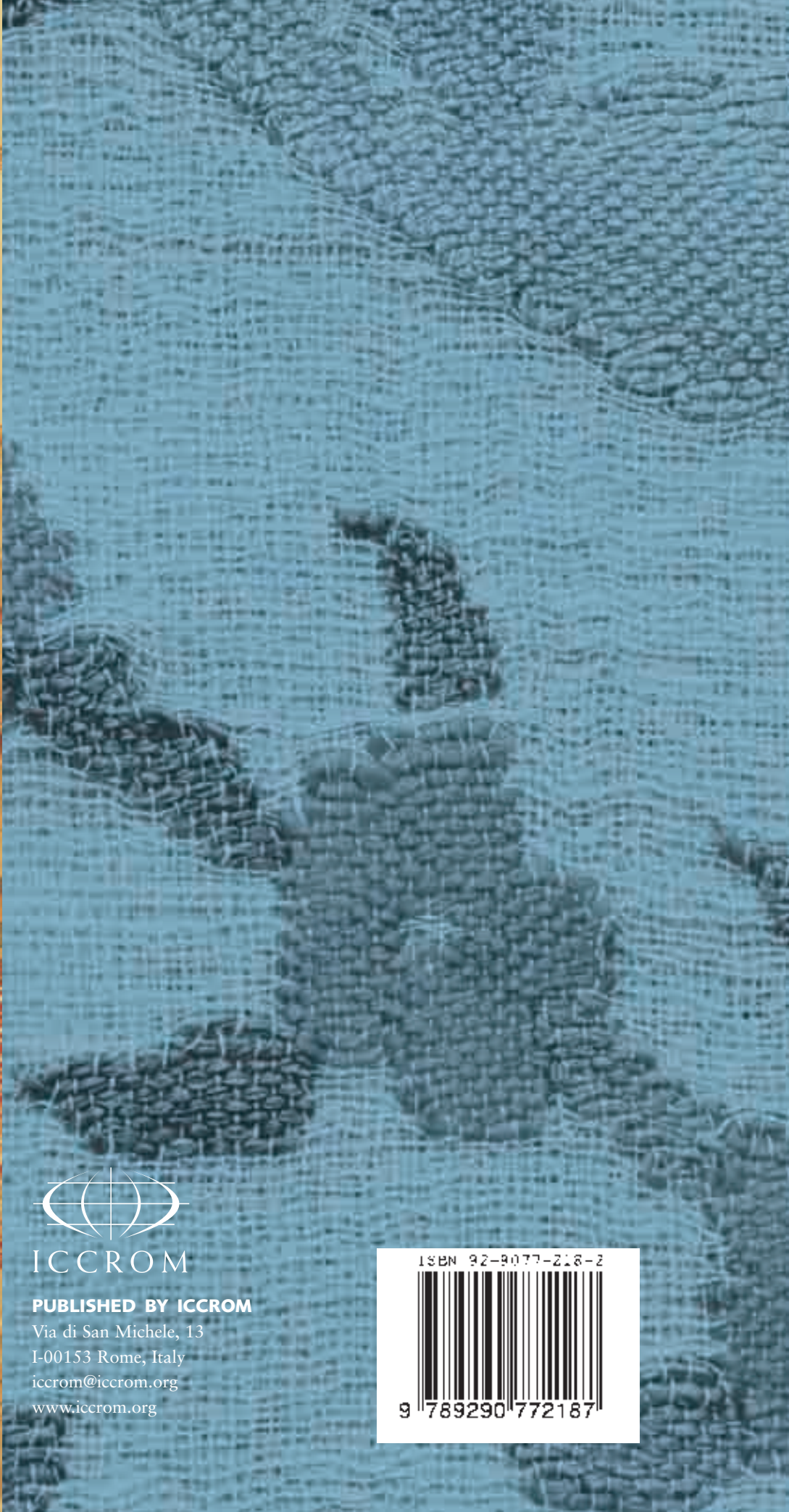

ICCROM

**PUBLISHED BY ICCROM**

Via di San Michele, 13

I-00153 Rome, Italy

[iccrom@iccrom.org](mailto:iccrom@iccrom.org)

[www.iccrom.org](http://www.iccrom.org)

ISBN 92-9077-218-2



9 789290 772187