



**Australian Government**  
**Department of Defence**  
 Defence Science and  
 Technology Organisation

## HMAS Sydney II Commission of Inquiry

### Report on Technical Aspects of the Sinking of HMAS *Sydney* and HSK *Kormoran*

*M. Buckland\**, *S.M. Cannon\*#*, *L. de Yong\**, *G.I. Gamble\**, *J.C. Jeremy#*, *T. Lyon#*  
*P. McCarthy\**, *B. Morris\*#*, *R.A. Neill\**, *M.B. Skeen\**, *B. Suendermann\** and  
*T. Turner\*#*

**\*Defence Science and Technology Organisation**  
 Maritime Platforms Division

**#Royal Institution of Naval Architects**  
 Australian Division

DSTO-GD-0559

#### **ABSTRACT**

This report describes the technical findings of the battle and sinking of HMAS Sydney and HSK Kormoran based on historical and archeological evidence. The battle occurred on the 19<sup>th</sup> of November, 1941 off the West Australian coast. The wrecks of the two ships were discovered in March 2008 and their subsequent underwater exploration has shed light on the events that took place during and after the battle.

This report was presented to the HMAS Sydney II Commission of Inquiry by the Defence Science and Technology Organisation (DSTO) and the Australian Division of the Royal Institution of Naval Architects (RINA) in January 2009.

*Approved for public release*

*Published by*

*Maritime Platforms Division  
DSTO Defence Science and Technology Organisation  
506 Lorimer St  
Fishermans Bend, Victoria 3207 Australia*

*Telephone: (03) 9626 7000*

*Fax: (03) 9626 7999*

*© Commonwealth of Australia 2009*

*AR-013-353*

*January 2009*

**APPROVED FOR PUBLIC RELEASE**

# HMAS Sydney II Commission of Inquiry

## Report on Technical Aspects of the Sinking of HMAS Sydney and HSK Kormoran

### Executive Summary

On the 19<sup>th</sup> of November 1941, the Royal Australian Navy Modified Leander Class light cruiser HMAS *Sydney*, en route to Fremantle, intercepted the disguised German raider the HSK *Kormoran* about 100 nautical miles west of Steep Point off the coast of Western Australia. In the ensuing battle, *Sydney* was sunk with the loss of the entire crew of 645 men. *Kormoran* was subsequently scuttled with the loss of 81 men.

Following the discovery of the wrecks of *Sydney* and *Kormoran* in March 2008, the Chief of the Defence Force, Air Vice Marshall A. G. Houston AC, AFC, established a Commission of Inquiry (COI), charged with the following Terms of Reference:

*To inquire into and report upon the circumstances associated with the loss of Sydney in November 1941 and consequent loss of life and related events thereto*

In support of these Terms of Reference, the Defence Science and Technology Organisation (DSTO) of the Department of Defence in collaboration with the Australian Division of the Royal Institution of Naval Architects (RINA) were appointed to provide expert advice and opinion.

The wreck site of *Kormoran* and *Sydney* were extensively surveyed by SV *Geosounder*. The footage was extensively analysed by DSTO and RINA to assess the extent and type of damage to both *Kormoran* and *Sydney*.

The analysis of the action between *Sydney* and *Kormoran* was bound by a number of assumptions concerning the battle sequence, the environmental factors and other operational aspects. These assumptions were provided by the COI.

In the provision of expert advice and opinion, DSTO and RINA used a number of scientific analysis tools. Aside from the physical examination of the video imagery, and a large number of historical documents, photographs and other publications, the analysis utilised modern computer codes. More importantly, advanced analysis techniques including a series of visualisations which have been included as Appendix C, have been used to determine the effects of the weapons damage on *Sydney*. Naval architectural assessments have been made to determine the probable final demise of *Sydney*.

The evidence from the wreck site of *Sydney* has been interpreted using not only factual evidence from the wreck but also from a consideration of evidence from similar events to other ships.

Observations made from the *Sydney* wreck site confirm *Kormoran* survivors' accounts of *Sydney* being hit in the bow by a torpedo and peppered with a large number of shells to both the port and starboard sides of the ship.

Observations of the footage of the wreck site of *Sydney* identify 87 individual 15 cm shell hits. Each of these shells weighed 45.3 kg, which represented a total weight of 3900 kg hitting *Sydney*. Each of these shells is designed to splinter on impact, generating a minimum of 200,000 individual steel fragments and thousands of secondary fragments as they smashed through *Sydney*. It is reasonable to suggest that a significant number of hits to the Upper deck regions cannot be identified due to the condition of the ship in its present state, so these numbers should be viewed as conservative.

It was not possible to identify the damage to *Sydney* from the smaller calibre shell impacts from the photographs. However, *Kormoran*'s survivors' accounts state that both the 20 mm and 3.7 cm guns peppered the upper decks and the bridge structure of *Sydney*.

*Kormoran* could bring to bear three of her five 20 mm guns at a time, each with a conservative firing rate of 100 rounds per minute (its design firing rate is stated as 240 rounds per minute). It would be reasonable to suggest that they would have sprayed *Sydney* with between 500 to 1000 rounds per gun during the encounter. These rounds would have been directed towards the exposed personnel and equipment on the upper decks.

*Kormoran*'s survivors have also stated they fired their 3.7 cm guns towards the bridge and superstructure regions. This gun had a more effective range than the 20 mm gun and had a rate of fire of 80 rounds per minute for the 0.7 kg AP shell. It is reasonable to suggest that *Kormoran* may have hit *Sydney* at least 400 times during the encounter, which would have added another 300 kg of steel fragments distributed around the upper decks and further added to the number of personnel critically wounded.

The battle between *Sydney* and *Kormoran* was a unique sea battle in that *Sydney* was not only hit by a torpedo, but was also pounded by accurate and sustained gun fire from close range for an extended period of time. Other WW2 ships had survived torpedo hits and others had survived shell hits from larger calibre shells. However, *Sydney* had to endure the sustained attack at close range from 15 cm shells smashing into the sides of the ship, raking the upper decks with 20 mm shells at a rate of fire of more than 100 rounds per minute and sustained shelling with 3.7 cm guns. As *Sydney* sustained hit after hit, the damage to both equipment and crew multiplied along with the loss of numerous capabilities. Figures presented propose that at least 70% of the crew were incapacitated or trapped in spaces due to fires and escape passages being blocked.

Fires broke out in many areas of the ship and choking smoke and toxic gases engulfed the upper decks and was drawn into the lower decks. The torpedo hit to the bow resulted in extensive forward flooding. The loss of the ship's electrical power and the physical blockage to passageways for egress would have made any damage control operations extremely difficult to conduct. Firemains and Main Suction lines would have been significantly damaged and the ability to pump water to fight the fires would have been further limited due to the lack of electrical power. This is particularly true for all areas forward of the machinery spaces. Although the initial action resulted in damage to the port side of *Sydney*, the turn to port after 5 minutes exposed *Sydney* to shelling on its starboard side and magnified the damage with as many shell hits on the starboard side as the port side. The boats and Carley floats on port and starboard sides were either blown

overboard or were directly damaged by shells or the thousands of fragments that were spraying around the upper decks. The boats and Carley floats were rendered useless for evacuation or lifesaving.

Given the torpedo strike to the forward part of the ship, the extensive weapons and fire damage to the midships and aft regions of the ship, it is highly likely that the only survivors were in the stern of the ship and possibly the aft engine room. The remaining crew would have been trying to save the ship by bringing it under control and possibly trying to carry out limited damage control. The surviving able bodied crew were likely to have been attempting to control the ship from the machinery spaces and steering compartments, provide electrical and fire fighting services, as well as assisting and treating the injured.

After the engagement the sea state increased as *Sydney* travelled to the south east at approximately 5 knots. At this time *Sydney* was severely damaged, with a very large number of casualties, several major fires, many small fires, much of the upper and lower decks filled with smoke, flooding occurring in the bow area and electrical power gone for much of the ship. The weapon holes were fuelling the fires by allowing air to ingress from outside. The damage control crews would have been overwhelmed at this stage and any damage control that was being conducted was simply to try to save the ship.

Any slight deviation from the beam-seas heading would have significantly changed the time the vessel remained afloat. As the sea conditions deteriorated to sea state 4, *Sydney* began to roll and more water flooded in through the weapons holes in the hull and deck openings. It is probable that the roll became significant and increased with flooding and increased sea state, rolling from 15° up to 40°. At these roll angles, immersion of the edge of *Sydney's* deck was likely and any attempt at damage control operations or movement around the ship would have been virtually impossible. Any survivors trapped below decks would simply have been trying to stop being thrown around. Eventually *Sydney* is likely to have rolled to an angle beyond which she could not have recovered, lost buoyancy and sank rapidly. It is possible that this process was also accompanied by the sudden collapse of one or more watertight bulkheads which further contributed to the sudden and catastrophic loss of buoyancy and sinking. For the damage extents considered, the analysis indicates that for all other headings considered, the time after the battle that *Sydney* could potentially remain afloat was somewhere between 2 to 4.5 hours. This is consistent with reports that the glow on the horizon from the fires onboard *Sydney* disappeared approximately 4.5 hours after the battle. As *Sydney* sank the weakened bow was violently torn off and plunged towards the sea floor.

It is not possible to factually state that there were any survivors from *Sydney* that entered the water. However, it is possible that some crew from *Sydney* entered the water at some stage during or after the engagement. Those during the engagement were likely to have been blown off the deck as a result of blast or fallen overboard. Those after the engagement were possibly swept off the decks when *Sydney* went down or entered the water if an abandon ship order was given. There is no evidence to support any of these statements and they must be seen as supposition. It should be noted that any survivors that did make it into the water would most likely have been affected by injuries, shock, burns and possibly the effects of smoke and/or inhalation of toxic fumes.

There is little doubt that the ship's boats were either damaged or were not able to be lifted off *Sydney* due to the aircraft crane being damaged. The Carley floats would have been either blown off during the engagement or damaged with shell hits, fragments or fire.

They would have been of little use. If any Carley floats did survive and floated, then it is possible that some survivors may have reached a float. Any other survivors would not have had anything other than their life belts to help them survive.

The survival time of someone wearing a life belt was hours. Although the Carley float provided a degree of survival capability, Royal Navy data suggests that a person in a Carley float would only survive for 3 to 5 days. Contemporary data and modelling on survival of people at sea show that at a water temperature of greater than 20 °C, hypothermia is not a critical factor. Data suggests that a person can survive for greater than 12 hours at 25°C and possibly up to 40-50 hours. It should be noted that none of this data can be validated.

Since neither *Sydney* nor *Kormoran* were accompanied by any other ships, nor were there any other ships in the immediate vicinity which were aware of the encounter, there was little possibility of survivors being picked up quickly.

Once in the water the major problem for survivors was drowning, dehydration and the presence of sea creatures particularly sharks. The water temperature in this area was approximately 23-24 °C, so hypothermia was not a significant factor in survival. If the survivors were supported only by a life belt, then the constant breaking of waves over the head could result in the ingestion of salt water leading to drowning. During the battle and the sinking of *Sydney* the sea states were 3 to 4. Given the limited support and buoyancy of the life belts, any survivors would most likely to have drowned and their bodies would have sunk.

As a body sinks into deep water, the pressure of the water tends to compress gases in the abdominal and chest cavities with the result that it displaces less water as it sinks deeper and consequently becomes less buoyant. Once a body sinks, it also commences to decompose due to the action and growth of anaerobic gas forming organisms in the intestines. The growth of these organisms causes the abdomen, followed by the whole body, to bloat and to swell with gases. The critical factor in this process is the water temperature. The lower the water temperature the slower is the rate of putrefaction. Once the body swells, it then rises to the surface where it floats. Typically, the time for a body to rise is between 3 and 10 days but can take much longer in cold waters and never at all if the water is very cold and/or if the body is lying at a great depth. In this case the survivors from the encounter would have sunk to a depth of approximately 2500 m. Given the significant water pressure on the body at this depth, it is likely that the putrefaction process would not result in enough gas generation to make the body buoyant. If, however, any bodies did rise to the surface, given the water temperature at 2500 m of approximately 2.5 °C, they would have taken longer than the typical 3-10 days to rise.

Based on this scenario, the searchers would not have found any bodies as they would not have risen to the surface, if at all, during the search period.

## Authors

**Mr. Michael Buckland BAppSc(Hons)**  
DSTO – Maritime Platforms Division

*Mr. Buckland is a Defence Scientist with the Australian Defence Science and Technology Organisation responsible for studies into the vulnerability of maritime platforms to the effects of weapons damage, and studies into weapon terminal effectiveness against maritime platforms. He has extensive experience in the weapons effects field and has participated in numerous full scale conventional weapon trials. He also spent 15 months as an exchange scientist at Defense Research Establishment Suffield in Canada studying the effects of underwater explosives.*

---

**Dr. Stuart M Cannon BSc(Hons), MSc, PhD,  
FRINA, CEng**  
DSTO – Maritime Platforms Division  
RINA

*Dr Cannon is Head of Surface Ship Structural Management and Task Leader for Surface Platform Systems at the Australian Defence Science and Technology Organisation. In this capacity he is responsible for all aspects of surface ship research for the Australian Defence Organisation. He has also advised the Defence Materiel Organisation on naval architectural aspects for many of the Royal Australian Navy current and future acquisition projects including the Armidale's Class patrol boats, the Canberra Class LHDs and the Hobart Class Air Warfare Destroyers.*

*Dr Cannon is currently the President of the Australian Division of RINA and he is a member of the Australian LRS Technical Committee. Dr Cannon holds a degree from Plymouth University, a masters from Cranfield Institute of Technology and a PhD from Brunel University.*

---

**Mr. Leo de Yong BAppSc(Chem.) MSc (Chem.)**  
DSTO – Maritime Platforms Division

*Mr. de Yong joined DSTO in 1982. He is currently Head of the Vulnerability, Damage Control, and Recoverability Group and Head of the Electromagnetic Signatures Group at the Australian Defence Science and Technology Organisation. In these capacities he is responsible for providing scientific solutions and design advice to the Australian Defence Organisation in the areas of survivability related to vulnerability, damage control and recoverability as well as radio frequency and electro-optic signature management. This research supports both the current and the future fleet particularly the Canberra Class LHDs and the Hobart Class Air Warfare Destroyers.*

*Mr. de Yong also has extensive research experience in military pyrotechnics and explosives.*

---

**Mr. Grant I Gamble BSc**  
DSTO – Maritime Platforms Division

*Grant Gamble works within the Defence Science and Technology Organisation in the fields of fire fighting, damage control, and lifesaving and evacuation to support current and future RAN surface ships and submarines. He has contributed to this area in computer based fire models and training aids, computational fluid dynamics modelling, fire risk analyses, laboratory and field experimentation, and technical risk analyses.*

*Grant Gamble graduated with a B.Sc with a joint major in Physics and Computer Science from La Trobe University in 1990, and joined the DSTO in 1991.*

---

**Mr. John C Jeremy BE, FIEAust, FRINA**  
RINA

*John Jeremy is a graduate in naval architecture from the University of New South Wales in Sydney. Most of his career was spent at Cockatoo Dockyard in Sydney where he was Managing Director/Chief Executive from 1981 to 1991.*

*He has been a member of the Royal Institution of Naval Architects since 1963 and is a past President of the Australian Division of RINA (1978–1985) and a member of the Australian Division Council from 1971 to 2003 and since 2005. He is currently editor-in-chief of The Australian Naval Architect and Chairman of the Publications Sub-committee of the Australian Division Council. He is also a Fellow of the Institution of Engineers (Australia) and a member of the Society of Naval Architects and Marine Engineers.*

---



**Mr. Tim Lyon BE, MRINA, CEng**  
RINA

*Mr Lyon is a professionally qualified naval architect and mechanical engineer, and a former ship design and project management specialist. Mr Lyon worked for 18 years in the Department of Defence and as a consultant to Defence for another nine years. Some relevant appointments during this period were as Head of the New Construction Group in the Directorate of Naval Ship Design, Design Manager for the ANZAC Ship Project, Assistant Design Manager (Hull) for the Australian Frigate Project, AOR Project and Minesweeper Project and consultant naval architect to the Armidale Class Patrol Boat Project. Mr Lyon is a Member of the Royal Institution of Naval Architects and a Member of the American Society of Naval Engineers, and is a Chartered Engineer. Mr Lyon is national treasurer for the Military Historical Society of Australia.*

---

**Mr. Patrick McCarthy AssDip**  
DSTO – Maritime Platforms Division

*Pat McCarthy graduated with a Certificate of Applied Science (Chemical Laboratory) from Footscray Technical College in 1984 and has since gained a Certificate of Technology (Metallurgy), RMIT 1986 and an Associate Diploma of OHS, Kangan 2000. He commenced work with DSTO in 1981, and is currently involved in research into the Vulnerability and Survivability of Naval Vessels*

---

**Mr. Brett Morris BEng**  
DSTO – Maritime Platforms Division  
RINA

*Brett Morris is a Naval Architect who joined DSTO in 2007. He has previously worked for the RAN in the Directorate of Navy Platform Systems and is currently working in the fields of Naval ship structures and hydrodynamics.*

---

**Dr. Roger A. Neill BSc, PhD**  
DSTO – Maritime Platforms Division

*Dr Neill is Head, Unmanned Maritime Systems and Task Leader Unmanned Maritime Systems at the Australian Defence Science and Technology Organisation. The research program for which he has responsibility is being used to guide Australian Defence Organisation as it moves towards making significantly greater use of unmanned systems in the maritime environment. He has had longstanding involvement on an international panel of experts on unmanned systems and he initiated, and was the inaugural convener of, the influential 'Shallow Survey' series of conferences.*

*Moving via a somewhat circuitous route, but substantially because of his expertise in the unmanned underwater vehicle domain, Dr Neill became involved in the structural assessment of the First World War Submarine HMAS AE2. This resulted in him developing considerable expertise in the interpretation and visualisation of historic naval shipwrecks.*

---

**Dr. Michael B. Skeen BE (Hons), PhD**  
DSTO – Maritime Platforms Division

*Dr Skeen is a Vulnerability Analyst with Naval Platforms Survivability at the Australian Defence Science and Technology Organisation.*

*Dr Skeen holds a Bachelor of Mechanical and Manufacturing Engineering from the University of Melbourne and a PhD from the University of New South Wales.*

---

**Ms. Brigitta Suendermann, BAppSc (Multi-Disp), MAppSci**  
DSTO – Maritime Platforms Division

*Brigitta joined the Defence Science and Technology Organisation (DSTO) in 1985, undertaking research into the effects of fire on life safety and asset protection on RAN vessels. This has involved mathematically modelling fire behaviour in multicompartment structures, involvement in fire trials and laboratory experiments.*

*Brigitta Suendermann graduated with a Bachelor of Applied Science (Multi-Disp.) from Chisholm Institute of Technology in 1985. She completed a Masters of Applied Science (Computed Tomography) in 1985*

---

**Mr. Terry Turner BSc MSc MRINA CEng**  
DSTO – Maritime Platforms Division  
RINA

*Terry Turner has been with DSTO for 19 years and has worked in the several areas including the Survivability/Vulnerability of Surface Platforms as well as the Naval Architecture Group. He has been involved in many projects ranging from the Ship Survivability Enhancement Program to seakeeping and stability analysis of various Naval Platforms.*

---

*This page intentionally blank*

# Contents

## LIST OF ABBREVIATIONS AND ACRONYMS

|   |           |
|---|-----------|
| <b>1. INTRODUCTION.....</b>   | <b>1</b>  |
| <b>1.1 Requests from the Commission of Inquiry .....</b>                | <b>2</b>  |
| 1.1.1 Initial request from the Commission of Inquiry – 6 May 2008 ..... | 2         |
| 2.1.2 Supplementary Instructions Number 1 – 16 May 2008 .....           | 7         |
| 2.1.3 Supplementary Instructions Number 2 – 18 August 2008 .....        | 9         |
| <b>1.2 Scientific Approach .....</b>                                    | <b>17</b> |
| 1.2.1 Vulnerability Analysis .....                                      | 17        |
| 1.2.1.1.1 <i>Sydney</i> model for XVAM analysis .....                   | 17        |
| 1.2.2 Flooding Analysis.....  | 18        |
| 1.2.2.1 Flooding Methodology .....                                      | 18        |
| 1.2.2.1.1 Numerical model preparation .....                             | 19        |
| 1.2.2.1.2 Hydrostatics .....  | 19        |
| 1.2.3 Seakeeping Loads Analysis.....                                    | 22        |
| 1.2.3.1 Model Development .....   | 22        |
| 1.2.4 Structural Integrity Analysis.....                                | 25        |
| 1.2.4.1 Model Development .....   | 25        |
| 1.2.5 Visualisation.....  | 26        |
| 1.2.6 Computer Aided Design (CAD) Modelling .....                       | 26        |
| 1.2.7 Fire Assessment .....   | 27        |
| 1.2.7.1.1 Admiral Graf Spee, 1939.....                                  | 28        |
| 1.2.7.1.2 HMS Sheffield, 1982.....                                      | 29        |
| 1.2.7.1.3 Royal Fleet Auxiliary (RFA) Sir Galahad, 1982.....            | 30        |
| 1.2.7.1.4 HMAS Westralia, 1998.....                                     | 31        |
| 1.2.7.1.5 Superferry 14, 2004.....                                      | 31        |
| 1.2.7.2 Fire spread.....  | 32        |
| 1.2.7.3 Examples of fire fighting in damaged ships.....                 | 33        |
| 1.2.7.3.1 HMS Arethusa, 1942 .....                                      | 33        |
| 1.2.7.3.2 HMS Liverpool, 1940 .....                                     | 33        |
| 1.2.7.3.3 HMS Southampton, 1941.....                                    | 34        |
| 1.2.7.3.4 HMAS Australia, 1945 .....                                    | 34        |
| 1.2.7.3.5 HMS Birmingham, 1943 .....                                    | 34        |
| 1.2.7.3.6 HMAS Hobart, 1943 .....                                       | 34        |
| 1.2.7.4 Examples of smoke and toxic gas in damaged ships .....          | 35        |
| 1.2.7.4.1 HMS Birmingham, 1943 .....                                    | 35        |
| 1.2.7.4.2 HMAS Australia, 1945 .....                                    | 35        |
| 1.2.7.4.3 Ex HMAS Derwent, 1994.....                                    | 35        |
| 1.2.7.4.4 Superferry 14, 2004.....                                      | 37        |
| 1.2.7.4.5 HMS Sheffield, 1982.....                                      | 37        |
| 1.2.7.4.6 Rusticles .....   | 38        |
| <b>2. HMAS SYDNEY DESIGN.....</b>                                       | <b>40</b> |

|            |   |            |
|------------|---|------------|
| <b>2.1</b> | <b>Overview .....</b>   | <b>40</b>  |
| 2.1.2      | Description of HMAS Sydney .....                                | 43         |
| 2.1.3      | Ships Drawings.....   | 45         |
| 2.1.4      | General Arrangement .....                                       | 59         |
| 2.1.5      | Armament.....   | 60         |
| 2.1.6      | Director Control System .....                                   | 62         |
| 2.1.7      | Aft Control Position .....                                      | 62         |
| 2.1.8      | 4" HA Guns .....  | 62         |
| 2.1.9      | High Angle Fire Control.....                                    | 63         |
| 2.1.10     | Torpedoes .....   | 63         |
| 2.1.11     | Depth Charges .....   | 65         |
| 2.1.12     | Smoke Laying.....   | 66         |
| 2.1.13     | Construction and Subdivision .....                              | 66         |
| 2.1.14     | Armour and Protective Plating .....                             | 69         |
| 2.1.15     | Machinery.....  | 71         |
| 2.1.16     | Steering Gear and Telemotor System .....                        | 73         |
| 2.1.16.1   | Description of Steering Gear.....                               | 73         |
| 2.1.16.2   | Principles of Operation.....                                    | 75         |
| 2.1.17     | Water Services.....   | 78         |
| 2.1.17.1   | Fresh Water - Cold.....   | 78         |
| 2.1.17.2   | Fresh Water - Hot.....  | 79         |
| 2.1.17.3   | Pumping, Flooding and Draining .....                            | 79         |
| 2.1.18     | Ventilation .....   | 81         |
| 2.1.18.1   | General description.....  | 81         |
| 2.1.18.2   | Machinery space ventilation .....                               | 84         |
| 2.1.18.3   | Electrical System.....  | 84         |
| 2.1.18.3.1 | High Power System.....  | 84         |
| 2.1.18.4   | Low Power System.....   | 86         |
| <b>2.2</b> | <b>Communication Systems .....</b>                              | <b>86</b>  |
| 2.2.1      | Internal Communication .....                                    | 86         |
| 2.2.2      | Ship to Shore .....   | 87         |
| 2.2.3      | Ship to Ship .....  | 88         |
| <b>2.3</b> | <b>Lifesaving Equipment.....</b>                                | <b>88</b>  |
| 2.3.1      | Carley Floats.....  | 88         |
| 2.3.2      | Ships Boats.....  | 96         |
| 2.3.3      | Other lifesaving equipment .....                                | 100        |
| 2.3.4      | Modifications after completion and Proposed Modernisation ..... | 101        |
| <b>3.</b>  | <b>OPERATIONAL ASPECTS OF HMAS SYDNEY.....</b>                  | <b>103</b> |
| <b>3.1</b> | <b>General Organisation.....</b>                                | <b>103</b> |
| 3.1.1      | Command and Control.....  | 103        |
| 3.1.2      | Crew Locations at Action Stations .....                         | 103        |
| <b>3.2</b> | <b>DC Organisation .....</b>                                    | <b>105</b> |
| 3.2.1      | Repair Party Makeup .....                                       | 106        |
| 3.2.2      | Medical.....  | 107        |
| 3.2.3      | Fire Fighting Capability.....                                   | 108        |
| 3.2.3.1    | Main Service/Firemain.....                                      | 108        |

|           |   |            |
|-----------|---|------------|
| 3.2.3.2   | Sea Water Pumps.....  | 108        |
| 3.2.3.3   | Main Suction .....  | 109        |
| 3.2.3.4   | Portable fire extinguishers and sand buckets.....             | 109        |
| 3.2.4     | Flooding/Spraying Arrangements .....                          | 109        |
| 3.2.5     | Furnishings and coatings .....                                | 111        |
| 3.2.6     | Personal Protection.....                                      | 112        |
| 3.2.7     | Emergency Power.....  | 112        |
| 3.2.7.1.1 | HMS Arethusa .....  | 112        |
| 3.2.7.1.2 | HMAS Australia .....  | 113        |
| 3.2.7.1.3 | HMS Liverpool .....   | 113        |
| 3.2.7.1.4 | HMS Birmingham .....  | 113        |
| 3.2.7.1.5 | HMAS Hobart.....  | 114        |
| 3.2.8     | DC equipment/procedures.....                                  | 114        |
| 3.2.8.1   | Shoring/Leak Stopping.....                                    | 114        |
| 3.2.8.2   | Flooding Boundaries.....                                      | 115        |
| 3.2.9     | Access Routes.....  | 115        |
| 3.2.10    | Examples of damage control in damaged ships .....             | 116        |
| 3.2.10.1  | HMS Arethusa .....  | 116        |
| 3.2.10.2  | HMS Liverpool .....   | 117        |
| 3.2.10.3  | HMAS Australia .....  | 117        |
| 3.2.10.4  | HMS Birmingham .....  | 117        |
| 3.2.10.5  | HMAS Hobart.....  | 117        |
| <b>4.</b> | <b>HSK KORMORAN.....</b>                                      | <b>119</b> |
| 4.1       | <b>Hull design.....</b>                                       | <b>119</b> |
| 4.1.1     | Machinery.....  | 120        |
| 4.1.1.1   | Propulsion .....  | 120        |
| 4.1.1.2   | Electrical Power .....  | 120        |
| 4.1.1.3   | Fresh Water Production.....                                   | 120        |
| 4.1.2     | Bunkers .....   | 120        |
| 4.1.3     | Ships boats.....  | 120        |
| 4.1.4     | Wireless telegraphy and visual signalling.....                | 121        |
| 4.1.5     | Protection.....   | 121        |
| 4.2       | <b>Weapons Systems .....</b>                                  | <b>121</b> |
| 4.2.1     | Main Armament and Fire Control .....                          | 121        |
| 4.2.1.1   | Fire Control .....  | 123        |
| 4.2.2     | Anti-Aircraft and sub-calibre armament.....                   | 123        |
| 4.2.2.1   | 3.7 cm Anti-aircraft Guns .....                               | 123        |
| 4.2.2.1.1 | Claims that the 3.7-centimetre guns were anti-tank guns ..... | 124        |
| 4.2.3     | 2 cm Cannon.....  | 124        |
| 4.2.4     | Light Machine Guns.....                                       | 124        |
| 4.2.5     | Other.....  | 125        |
| 4.2.6     | Torpedoes .....   | 125        |
| 4.2.6.1   | Deck-mounted Torpedo Tubes.....                               | 125        |
| 4.2.6.2   | Underwater Torpedo Tubes.....                                 | 125        |
| 4.2.6.3   | Torpedoes .....   | 125        |
| 4.2.6.4   | Mines .....   | 126        |

|            |   |            |
|------------|---|------------|
| 4.2.6.5    | Minelaying Motor Boat.....                                      | 126        |
| <b>4.3</b> | <b>Aircraft Arrangements .....</b>                              | <b>126</b> |
| <b>4.4</b> | <b>Searchlights.....</b>  | <b>126</b> |
| <b>4.5</b> | <b>Smoke generation .....</b>                                   | <b>126</b> |
| <b>4.6</b> | <b>Nature of camouflaging of armament and fire control.....</b> | <b>127</b> |
| 4.6.1      | Main Armament .....   | 127        |
| 4.6.1.1    | No.1 and No.2 Gun .....   | 127        |
| 4.6.1.2    | No. 3 and No. 4 Gun .....                                       | 128        |
| 4.6.1.3    | No.5 and No.6 Gun .....   | 129        |
| 4.6.1.4    | Fire Control .....  | 129        |
| 4.6.2      | Anti-Aircraft Armament.....                                     | 129        |
| 4.6.2.1    | 3.7 cm Anti-aircraft Guns .....                                 | 129        |
| 4.6.2.2    | 2 cm Cannon.....  | 129        |
| 4.6.3      | Torpedoes .....   | 130        |
| 4.6.3.1    | Deck-mounted Torpedo Tubes.....                                 | 130        |
| 4.6.4      | Mines .....   | 131        |
| 4.6.4.1    | Minelaying Motor Boat.....                                      | 131        |
| 4.6.5      | Aircraft arrangements.....                                      | 132        |
| <b>4.7</b> | <b>Time to de-camouflage and open fire .....</b>                | <b>133</b> |
| 4.7.1      | Operational Assumptions .....                                   | 133        |
| 4.7.2      | 15 cm Guns .....  | 133        |
| 4.7.2.1    | Forward Starboard No. 1 Gun.....                                | 133        |
| 4.7.2.2    | Centreline guns within the cargo holds (No. 3 and 4) .....      | 134        |
| 4.7.2.3    | Aft starboard gun No. 5 gun.....                                | 134        |
| 4.7.3      | 3.7 cm anti-aircraft guns .....                                 | 134        |
| 4.7.4      | Deck Mounted Torpedoes.....                                     | 134        |
| 4.7.5      | Fixed Underwater Torpedoes.....                                 | 134        |
| 4.7.6      | Conclusions .....   | 135        |
| <b>5.</b>  | <b>EVIDENCE FROM THE WRECK SITE .....</b>                       | <b>136</b> |
| <b>5.1</b> | <b>HSK Kormoran Wreck Site .....</b>                            | <b>136</b> |
| 5.1.1      | Debris Field .....  | 136        |
| 5.1.2      | Identification of Kormoran guns and camouflaging.....           | 136        |
| 5.1.3      | Above-water Torpedo.....  | 139        |
| 5.1.4      | Below-water Torpedo tube .....                                  | 140        |
| 5.1.5      | Kormoran's vulnerability to shell fire .....                    | 141        |
| <b>5.2</b> | <b>HMAS Sydney Wreck Site .....</b>                             | <b>144</b> |
| 5.2.1      | Debris Field .....  | 144        |
| 5.2.2      | Torpedo Damage .....  | 145        |
| 5.2.3      | Shell and Fragment Damage.....                                  | 152        |
| 5.2.4      | Fire Damage .....   | 170        |
| 5.2.5      | Ship's boats and Carley floats.....                             | 171        |
| 5.2.6      | Other Structural Damage .....                                   | 183        |
| 5.2.6.1    | Separation of the Bow .....                                     | 183        |
| 5.2.6.1.1  | Implosion damage.....   | 185        |
| 5.2.6.1.2  | Impact with the seabed.....                                     | 187        |
| 5.2.6.1.3  | Collision Damage .....  | 191        |



|           |  |            |
|-----------|--|------------|
| 5.2.7     | Damage due to deterioration.....   | 191        |
| 5.2.8     | Weapon Systems.....  | 194        |
| 5.2.8.1.1 | 6" Guns and Fire Control.....  | 194        |
| 5.2.8.1.2 | 4" HA Guns and Fire Control.....   | 198        |
| 5.2.8.1.3 | Small Calibre Weapons.....   | 201        |
| 5.2.8.1.4 | Torpedoes.....   | 202        |
| <b>6.</b> | <b>ASSUMPTIONS.....</b>  | <b>208</b> |
| 6.1       | <b>The course of the interception and encounter between <i>Sydney</i> and <i>KORMORAN</i> [283].....</b> | <b>208</b> |
| 6.2       | <b>List of Assumptions about the Disposition of the Crew at Action Stations [71].....</b>                | <b>211</b> |
| <b>7.</b> | <b>INTERPRETATION OF EVIDENCE.....</b>   | <b>214</b> |
| 7.1       | <b>Introduction.....</b>   | <b>214</b> |
| 7.1.1     | Weapons Effects.....   | 214        |
| 7.1.1.1.1 | Weapon Damage Analysis Process.....  | 214        |
| 7.1.1.1.2 | High Explosive (HE) shell damage mechanisms.....   | 215        |
| 7.1.1.1.3 | Small arms fire damage mechanisms.....   | 215        |
| 7.1.1.1.4 | Description of 15 cm shells used in analysis.....  | 216        |
| 7.1.1.1.5 | Weapon Trajectories.....   | 217        |
| 7.1.1.1.6 | Extent of damage.....  | 218        |
| 7.2       | <b>Port side engagement.....</b>   | <b>219</b> |
| 7.2.1     | Torpedo Damage.....  | 219        |
| 7.2.1.1.1 | Torpedo Damage Mechanisms.....   | 219        |
| 7.2.1.1.2 | Examples of Torpedo Damage.....  | 220        |
| 7.2.1.2   | Flooding Consequence of Torpedo damage.....  | 221        |
| 7.2.2     | Shell Damage.....  | 224        |
| 7.2.3     | Fire Damage.....   | 233        |
| 7.2.3.1.1 | Smoke and Toxic Gas.....   | 233        |
| 7.2.4     | Casualties.....  | 235        |
| 7.3       | <b>Possible movement of Executive Officer (XO).....</b>  | <b>237</b> |
| 7.3.1     | Route 1.....   | 237        |
| 7.3.2     | Route 2.....   | 238        |
| 7.3.3     | Route 3.....   | 240        |
| 7.3.4     | Route 4.....   | 241        |
| 7.4       | <b>Turn to Port.....</b>   | <b>242</b> |
| 7.5       | <b>Starboard Side Engagement.....</b>  | <b>243</b> |
| 7.5.1     | Shell damage.....  | 243        |
| 7.5.2     | Fire Damage.....   | 250        |
| 7.5.3     | Casualties.....  | 250        |
| 7.6       | <b>Point of Disengagement.....</b>   | <b>250</b> |
| 7.6.1     | Integrity of ship.....   | 251        |
| 7.6.1.1   | Overall Shell Damage.....  | 251        |
| 7.6.1.1.1 | Description of damage to <i>Sydney</i> via XVAM analysis.....  | 251        |
| 7.6.1.1.2 | Estimate of casualties.....  | 255        |

|            |  |            |
|------------|--|------------|
| 7.6.1.1.3  | Weapon Effects Conclusions.....                    | 258        |
| 7.6.2      | Damage Control.....                                | 259        |
| 7.6.2.1    | Access.....  | 260        |
| 7.6.2.2    | Flooding.....                                      | 261        |
| 7.6.2.3    | Fire fighting.....                                 | 261        |
| 7.6.2.4    | Smoke ingress.....                                 | 261        |
| 7.6.2.5    | Electrical.....                                    | 262        |
| 7.6.2.6    | Trim.....  | 263        |
| 7.6.2.7    | Damage control constraints.....                    | 263        |
| 7.6.2.8    | Medical.....                                       | 264        |
| 7.6.2.9    | After Action – Lifesaving Equipment.....           | 264        |
| 7.6.2.10   | Communications.....                                | 265        |
| 7.6.2.11   | After the battle.....                              | 266        |
| <b>7.7</b> | <b>The Loss of <i>Sydney</i>.....</b>              | <b>268</b> |
| 7.7.1      | Structural Integrity.....                          | 268        |
| 7.7.1.1    | Analysis of Longitudinal Strength.....             | 268        |
| 7.7.1.1.1  | Introduction.....                                  | 268        |
| 7.7.1.1.2  | Sea Loads.....                                     | 269        |
| 7.7.1.1.3  | Ultimate Strength.....                             | 269        |
| 7.7.1.1.4  | Comparison of Sea Loads and Ultimate Strength..... | 270        |
| 7.7.1.1.5  | Conclusion.....                                    | 275        |
| 7.7.1.2    | Watertight Bulkhead Strength.....                  | 275        |
| 7.7.1.2.1  | Introduction.....                                  | 275        |
| 7.7.1.2.2  | Literature Review.....                             | 275        |
| 7.7.1.2.3  | Analysis.....                                      | 276        |
| 7.7.1.2.4  | Conclusions.....                                   | 278        |
| 7.7.2      | Time to flood.....                                 | 278        |
| 7.7.2.1    | Damage Extents.....                                | 278        |
| 7.7.2.2    | Assumptions.....                                   | 278        |
| 7.7.2.2.1  | Sea States.....                                    | 278        |
| 7.7.2.2.2  | Speeds.....  | 278        |
| 7.7.2.2.3  | Headings.....                                      | 279        |
| 7.7.2.2.4  | Durations.....                                     | 279        |
| 7.7.2.3    | Analysis.....                                      | 279        |
| 7.7.2.4    | Results.....                                       | 281        |
| 7.7.2.4.1  | Scenario 1 - Damage to Hull Structure Only.....    | 281        |
| 7.7.2.4.2  | Scenario 2 - Observed and Predicted Damage.....    | 284        |
| 7.7.2.5    | Conclusion.....                                    | 286        |
| 7.7.3      | Final Demise.....                                  | 286        |
| 7.7.4      | Sinking to the seabed.....                         | 288        |
| <b>7.8</b> | <b>The Search for <i>Sydney</i>.....</b>           | <b>291</b> |
| <b>7.9</b> | <b>Likelihood of survivors.....</b>                | <b>295</b> |
| 7.9.1      | Survival in the water.....                         | 295        |
| 7.9.2      | Why No Survivors?.....                             | 298        |

|   |            |
|---|------------|
| 8. CONCLUDING REMARKS .....                                       | 300        |
| 9. ACKNOWLEDGEMENTS .....   | 301        |
| 10. REFERENCES .....  | 302        |
| <b>APPENDIX A: HMAS SYDNEY COI 2008.....</b>                      | <b>315</b> |
| <b>A.1. Survey of Shell and Fragment Damage to HMAS Sydney ..</b> | <b>315</b> |
| A.1.1 Numbering Convention used in weapon damage<br>survey .....  | 315        |
| A.1.2 Shell and Fragment Damage Description.....                  | 315        |
| A.1.3 Shell and Torpedo damage to HMAS <i>Sydney</i> .....        | 317        |
| A.1.4 Port side damage - Class A Damage .....                     | 321        |
| A.1.5 Port side damage - Class B Damage .....                     | 332        |
| A.1.6 Port side damage - Class C Damage.....                      | 342        |
| A.1.7 Starboard side damage - Class A Damage.....                 | 346        |
| A.1.8 Starboard side damage - Class B Damage .....                | 357        |
| A.1.9 Starboard side damage - Class C Damage.....                 | 373        |
| <b>APPENDIX B: HMAS SYDNEY – AS FITTED DRAWINGS .....</b>         | <b>379</b> |
| <b>APPENDIX C: VISUALISATIONS OF HMAS SYDNEY.....</b>             | <b>389</b> |

*This page intentionally blank*

## List of Abbreviations and Acronyms

|                       |  |
|-----------------------|--|
| <b>AA</b>             | Antiaircraft   |
| <b>AP</b>             | Armour Piercing  |
| <b>ASDIC</b>          | Anti-Submarine Detection Investigation Committee                         |
| <b>BB</b>             | Branch Breakers  |
| <b>BKD</b>            | Bulkhead   |
| <b>BL</b>             | Breech Loaded  |
| <b>BM<sub>t</sub></b> | Vertical distance between centre of buoyancy and transverse metacentre   |
| <b>CAD</b>            | Computer Aided Drafting  |
| <b>Cm</b>             | centimetre   |
| <b>COI</b>            | Commission of Inquiry  |
| <b>CSA</b>            | Cross-Section Area   |
| <b>CW</b>             | Continuous Wave  |
| <b>DC</b>             | Damage Control   |
| <b>DCHQ</b>           | Damage Control Headquarters  |
| <b>DCT</b>            | Director Control Tower   |
| <b>DSTO</b>           | Defence Science and Technology Organisation                              |
| <b>F&amp;B</b>        | Fire and Bilge   |
| <b>FSF</b>            | Finding Sydney Foundation  |
| <b>FW</b>             | Fresh Water  |
| <b>GA</b>             | General Arrangement Drawing  |
| <b>GM</b>             | Transverse Metacentric Height  |
| <b>HA</b>             | High Angle   |
| <b>HACP</b>           | High Angle Calculating Position  |
| <b>HACS</b>           | High Angle Control Station   |
| <b>HE</b>             | High Explosive   |
| <b>HMAS</b>           | Her Majesty's Australian Ship  |
| <b>HMAS</b>           | His Majesty's Australian Ship (1941)                                     |
| <b>HMS</b>            | Her Majesty's Ship   |
| <b>HMS</b>            | His Majesty's Ship (1941)  |
| <b>HSK</b>            | Hilfskreuzer   |
| <b>KB</b>             | Vertical distance between the baseline and transverse centre of buoyancy |
| <b>kg</b>             | Kilogram   |
| <b>KG</b>             | Vertical Centre of Gravity   |
| <b>km</b>             | Kilometre  |
| <b>kW</b>             | Kilowatt   |

|               |   |
|---------------|---|
| <b>LCB</b>    | Longitudinal Centre of Buoyancy             |
| <b>LCF</b>    | Longitudinal Centre of Floatation           |
| <b>LCG</b>    | Longitudinal Centre of Gravity              |
| <b>LOA</b>    | Length Overall                              |
| <b>LPP</b>    | Length between Perpendiculars               |
| <b>LWL</b>    | Length Waterline                            |
| <b>MD</b>     | Medical Distribution                        |
| <b>m/s</b>    | Metres per second                           |
| <b>MT</b>     | Mushroom Top                                |
| <b>PRECAL</b> | Pressure Calculation Computer Software Code |
| <b>RAN</b>    | Royal Australian Navy                       |
| <b>RFA</b>    | Royal Fleet Auxiliary                       |
| <b>RINA</b>   | Royal Institution of Naval Architects       |
| <b>ROV</b>    | Remotely Operated Vehicle                   |
| <b>RMB</b>    | Ring Main Breakers                          |
| <b>rpm</b>    | Rounds per minute                           |
| <b>RU</b>     | Ready Use                                   |
| <b>SAR</b>    | Search and Rescue                           |
| <b>SEO</b>    | Squadron Engineering Officer                |
| <b>SHP</b>    | Shaft Horse Power                           |
| <b>SV</b>     | Survey Vessel                               |
| <b>TS</b>     | Transmitting Station                        |
| <b>TNT</b>    | Trinitrotoluene                             |
| <b>ULTSTR</b> | Ultimate Strength Computer Software Code    |
| <b>US</b>     | United States                               |
| <b>USS</b>    | United States Ship                          |
| <b>W/T</b>    | Wireless Telegraphy                         |
| <b>WT</b>     | Watertight                                  |
| <b>WTB</b>    | Watertight Transverse Bulkhead              |
| <b>WWI</b>    | World War One                               |
| <b>WWII</b>   | World War Two                               |
| <b>XO</b>     | Executive Officer                           |
| <b>XVAM</b>   | Vulnerability Assessment Method             |

## 1. Introduction

On the 19<sup>th</sup> of November 1941, the Royal Australian Navy Modified Leander Class light cruiser *Sydney* en route to Fremantle, intercepted the disguised German raider, *Kormoran*, about 100 nautical miles west of Steep Point off the coast of Western Australia. In the ensuing battle, *Sydney* was sunk with the loss of the entire crew of 645 men. *Kormoran* was subsequently scuttled with the loss of 81 crew.

Several days after *Sydney* was expected to reach Fremantle, attempts were made to contact the ship with no success. A search was mounted on the 24<sup>th</sup> November and continued until the 29<sup>th</sup> November but no survivors or significant wreckage of either ship was found. Of *Kormoran* crew, 317 were rescued at sea or reached the coast in lifeboats.

Much of the evidence regarding the battle and the loss of both ships has come from the German survivors.

On the 12<sup>th</sup> of March 2008, a remotely operated vehicle (ROV) from the *Geosounder*, confirmed the finding of the wreck of *Kormoran* and subsequently on the 16<sup>th</sup> of March, the wreck of *Sydney* some 12 nautical miles from *Kormoran* at a depth of 2470 metres. The wrecks were found 112 miles off Steep Point off the coast of Western Australia.

On 28<sup>th</sup> March 2008, a Commission of Inquiry (COI) was established by the Chief of the Defence Force and charged by the Appointing Authority with the following terms of reference:

*To inquire into and report upon the circumstances associated with the loss of Sydney in November 1941 and consequent loss of life and related events thereto*

In support of these terms of reference, the Defence Science and Technology Organisation (DSTO) of the Department of Defence in collaboration with the Australian Division of the Royal Institution of Naval Architects (RINA) were appointed on 6<sup>th</sup> May 2008 to provide expert advice and opinion.

This report outlines the findings of DSTO and RINA in relation to the terms of reference stated above.

DSTO-GD-0559

## 1.1 Requests from the Commission of Inquiry

### 1.1.1 Initial request from the Commission of Inquiry – 6 May 2008



HMAS SYDNEY II  
COMMISSION OF INQUIRY  
Office of the Chief of the Defence Force  
270 Pitt St  
Defence Plaza Sydney  
Sydney NSW 2000

HMAS SYDNEY II COI/OUT/2008/2  
EK 116874

Ms Janet Cocking  
Chief, Maritime Platforms Division  
Defence Science and Technology Organisation  
506 Lorimer Street  
FISHERMANS BEND VIC 3207

Dear Ms Cocking,

I refer to the meeting attended to by Lieutenant Stephen Harper RANR as Principal Solicitor and myself as Senior Counsel to the HMAS SYDNEY II Commission of Inquiry, at DSTO in Melbourne on 28 April 2008.

We were pleased to meet with you and your Maritime Platforms Division colleagues to generally discuss the intention of Counsel Assisting, HMAS SYDNEY II Commission of Inquiry to appoint DSTO on behalf of the President of the Commission of Inquiry the Hon. T.R.H. Cole, AO, RFD, QC as experts in relation to this matter.

The Commission of Inquiry appointed by the Chief of the Defence Force on 28 March 2008 was charged by the Appointing Authority with the following Terms of Reference;

*To inquire into and report upon circumstances associated with the loss of HMAS SYDNEY II in November 1941 and consequent loss of life and related events subsequent thereto*

I enclose for your information a copy of the Instrument of Appointment of Counsel Assisting by Chief of Defence Force dated 11 April 2008.

I confirm the appointment of DSTO as experts to assist the HMAS SYDNEY II Commission of Inquiry as detailed in this letter and as may be varied from time to time during the Inquiry on direction from Counsel Assisting.

#### Instructions

On a preliminary matter, we have been in contact with Mr John Jeremy of the Royal Institute of Naval Architects ("RINA"). He has informed Counsel Assisting of the keen interest and expertise within RINA to assist the Inquiry with expert opinion on a number of areas crucial to attempt to establish the proximate cause of the loss of HMAS SYDNEY II off the coast of Western Australia in November 1941 following an engagement with HSK KORMORAN.



DSTO-GD-0559

As discussed with you we agree there is considerable merit in DSTO and RINA working together on this matter to provide expert advice to the Inquiry. The circumstances leading to the loss of HMAS SYDNEY II in 1941 present, to an Inquiry in 2008, a challenge to the understanding and appreciation of many aspects of naval ship construction, weaponry, gunnery and the effects of explosive ordinance on ships in an engagement at that time. RINA has, as we understand it, a number of members with expertise in WWII naval architecture, naval ship construction and naval weaponry. The combining of resources we are confident is in the best interests of a sound comprehensive Report to the Inquiry.

We will copy this letter to RINA and suggest that they discuss with DSTO the way forward so as to provide suitable expertise from within the membership of the Institute to assist DSTO with the provision of expert advice and opinion to the Commission of Inquiry.

Counsel Assisting on behalf the Inquiry seeks expert advice and opinion from DSTO on the following matters;

#### **HMAS SYDNEY II**

Provide an overview of the construction and general arrangement of HMAS SYDNEY II from a naval architecture perspective taking into account;

- the ship as constructed and any subsequent modifications or additions after delivery into service with the Royal Australian Navy;
- weaponry and armaments;
- damage control procedures and survivability/flooding criteria when incurring battle damage;
- life saving appliances, battle protection features such as armour hull plating, alternate propulsion/generator plants, emergency steering arrangements, W/T arrangements and emergency alternate procedures; and
- 6 inch gun firing arrangements from director control and single turrets.

#### **HSK KORMORAN**

- a general description of HSK KORMORAN including conversion from a merchant ship to armed raider, armaments including concealing of 15cm guns in holds, underwater torpedo tubes, W/T equipment, D/F and transmission jamming ability and engine capabilities; and
- a specific aspect of HSK KORMORAN we would seek to have addressed if possible is the nature of camouflaging of armament and the like and the approximate time from the order to decamouflage to firing on an enemy ship at a range of 1200-1500 metres.

DSTO-GD-0559

### **Engagement and Damage**

Subject to further discussion with you we envisage your report covering two scenarios in relation to battle damage sustained by both ships;

(A). Using video recently taken by ROV from survey vessel GEOSOUNDER at HMAS SYDNEY II wreck site (26 Degrees 14' 37" S, 111 Degrees 13' 03" E) and HSK KORMORAN wreck site (26 Degrees 05' 49" S, 111 Degrees 04' 27" E) DSTO is requested to assess and report on;

-the location of the damage to both ships;

-the cause of the damage to both ships e.g. gunfire (type of gun /type of shell) torpedo, explosive ordinance/munitions on board;

-the impact of HSK KORMORAN gunnery and torpedo hits on HMAS SYDNEY II including such effects on;

(i). engines and propulsion systems ability to make way;

(ii). the bridge and any subsequent impact on control of the ship; and

(iii). control of the ship generally including damage control, steering, electrical systems, guns and weapons systems, communications systems (both internal and external W/T), life saving equipment including boats and floatation devices and fire fighting abilities.

(B). Counsel Assisting in due course will provide to DSTO a series of assumptions concerning the engagement in the form of a chronological description of the battle detailing a reconstruction of the battle noting weapons and armaments used and damage observed; from this material DSTO is requested to plot on technical drawings of HMAS SYDNEY II damage sustained and the effect of such damage on operational capability of the ship and the structural integrity of the ship. The chronological description of the battle will be based on the accounts provided by HSK KORMORAN survivors. We seek a comparison between the chronological description provided and your findings after assessment of the ROV video material so as to determine the veracity of the survivor accounts.

### **Loss of HMAS SYDNEY II**

DSTO is also requested to provide an opinion as to the proximate (or dominant) cause of the sinking of HMAS SYDNEY II some hours after the engagement with HSK KORMORAN.

In addition Counsel Assisting seek advice from DSTO concerning the following issues;

- the sequence of sinking of the ship taking into account the apparent loss of bow;

*Defending Australia and its National  
Interests*

DSTO-GD-0559

- whether any warning as to the impending loss of the ship would have been given/known by such of the ship's company as may have still been alive at this time;
- what were the chances of survival for such of the ship's company as may have survived the engagement taking into account whether such persons were on or below decks;
- whether any opinion can be offered as a consequence of the DSTO examination of the wreck to explain why there were no survivors from the sinking of HMAS SYDNEY II (leaving aside whether the body found off Christmas Island in 1942 in a Carley Float is ex HMAS SYDNEY II);
- whether in the opinion of DSTO the fact that there were no survivors in all the circumstances is an unusual consequence of the sinking of HMAS SYDNEY II; and
- whether there is any comparison to be made with other examples of warships sinking with no or very few survivors.

#### **Other Matters**

Counsel Assisting are taking steps to obtain all relevant archival materials and documents from sources in Australia (National Archives, Australian War Memorial, Western Australian Maritime Museum, National Library) and overseas (United Kingdom, Germany and United States). These documents will include, it is anticipated, technical data and drawings of both HSK KORMORAN and HMAS SYDNEY II. Such materials will be supplied to DSTO in due course. In the interim, DSTO should consider informing Counsel Assisting of the type of documents that would assist.

At this stage Counsel Assisting can supply with these instructions a CD-ROM with various plans of HMAS SYDNEY II disclosing general arrangements, deck and hatch plans as well as photographs taken of two models of HMAS SYDNEY II which assist with a visual familiarisation of the layout and characteristics of the ship. A paper prepared by weather experts which assesses the weather at an assumed engagement site area of 26 S 111E is enclosed.

#### **Presentation of expert evidence to the Commission of Inquiry**

While expert opinion by way of written Report(s) will be tendered formally to the Commission, it will be requested that DSTO (including RINA) appear before the Inquiry at a public hearing to report upon matters to the President.

From the experience of Counsel Assisting with previous Inquiries, this can be done by presentations by several members of the DSTO team in a format that complements the overall Report such a PowerPoint presentation. Counsel Assisting are firmly of the view that an overall video simulation of the engagement between HSK KORMORAN and HMAS SYDNEY II on 19 November 1941 together with a graphics/video simulation of damage to both ships and the sinking of HMAS SYDNEY II would prove invaluable not only to the Commission of Inquiry but also to the public in otherwise explaining a complex scenario with inputs from a range of technical experts.

DSTO-GD-0559

As previously stated, please regard these instructions as preliminary and general.

Counsel Assisting will update DSTO during the course of the Inquiry regularly as issues develop and documentary materials become available.

Throughout the Inquiry, DSTO should liaise with Lieutenant Stephen Harper RANR as Principal Solicitor and/or myself as Senior Counsel Assisting the Inquiry.

Yours Sincerely,



**J.T. RUSH, RFD, QC**  
Commander RANR  
Counsel Assisting  
HMAS SYDNEY II  
Commission of Inquiry  
Level 11  
Defence Plaza  
270 Pitt Street  
SYDNEY NSW 2000

Phone: 02 9377 2121

Fax: 02 9377 2177

Mobile: 0412 715 692

Email: [john.rush@defence.gov.au](mailto:john.rush@defence.gov.au)

6 May 2008

DSTO-GD-0559

## 2.1.2 Supplementary Instructions Number 1 - 16 May 2008



HMAS SYDNEY II  
 COMMISSION OF INQUIRY  
 Office of the Chief of the Defence Force  
 270 Pitt St  
 Defence Plaza Sydney  
 Sydney NSW 2000

HMAS SYDNEY II COI/OUT/2008/25

2K117882

Ms Janis Cocking  
 Chief, Maritime Platforms Division  
 Defence Science and Technology Organisation  
 506 Lorimer Street  
 FISHERMANS BEND VIC 3207

Dear Ms Cocking,

**Supplementary Instructions-Number 1-HMAS SYDNEY II**

I refer to the letter from Counsel Assisting, CMDR JT Rush RFD, QC RANR dated 6 May 2008 appointing DSTO as experts to assist the HMAS SYDNEY II Commission of Inquiry.

As detailed in the letter from Counsel Assisting, we will from time to time during the course of the Inquiry request from you, further expert opinion on matters relevant to the Inquiry.

Please regard this letter as supplementary instructions.

You will in due course, when we are in a position, be provided with the ROV underwater video footage of the wreck of HMAS SYDNEY II. You will be able to observe that the bow section of the vessel appears to us to have sustained torpedo damage. If it is torpedo damage, that may be consistent with HSK KORMORAN survivors accounts of a torpedo fired from HSK KORMORAN impacting with the bow of HMAS SYDNEY II approximately twenty yards aft of the bow.

We are particularly interested to know whether the bow damage is consistent with the impact effect of the warhead used in a German torpedo or whether the impact damage could be regarded as being more consistent with the size of warhead used in Japanese World War Two torpedos.

The reason for us seeking your advice in relation to the bow damage of HMAS SYDNEY II is for us as Counsel Assisting to be able to put a submission to the Inquiry that either says that HSK KORMORAN acted alone in the engagement with HMAS SYDNEY II or whether the Germans had assistance from a third party such as a Japanese 'I' Class Submarine. The intervention of a Japanese Submarine has been suggested in a number of books and articles written over the years and is one of a number of theories that Counsel Assisting will need to examine in relation to an assessment of the proximate cause of the sinking of the HMAS SYDNEY II.

We will once we have accessed archival materials relating to HSK KORMORAN advise you as to what we believe were the type of torpedos carried on board HSK KORMORAN but at this stage we tend to the view that they were G7a 21" 661 lb charge, 23'7" long and / or

*Defending Australia and its National Interests*

DSTO-GD-0559

G7e 21" 440 lb charge, 23'7" long type torpedos. In contrast Japanese 'I' Class Submarines carried we understand a Type 95 21" 893 lb charge, 23'5" long torpedo which was also known as a 'Long Lance'. In short what we are seeking from DSTO is an opinion as to whether on the evidence that will be available in due course by way of the ROV survey materials, was HMAS SYDNEY II hit on the port side bow by a torpedo with the size of warhead used in a G7a and or a G7e German torpedo or larger warhead size more consistent with a Japanese type 95 'Long Lance' torpedo?

Alternatively, if it is a German torpedo, are you able to distinguish whether the torpedo was a torpedo from HSK KORMORAN'S underwater tubes or her waist mounted torpedo tubes, or a torpedo from a German U-Boat ?

Another alternative might be shellfire which perforated the hull and caused plates to come away. Could you please consider if the damage sustained would be consistent with such a scenario.

We anticipate being in a position to supply you with the ROV survey materials by the end of May 2008.

Yours Sincerely,



**S.D. HARPER**  
Lieutenant RANR  
Principal Solicitor  
Counsel Assisting  
HMAS SYDNEY II  
Commission of Inquiry  
Level 11  
Defence Plaza  
270 Pitt Street  
SYDNEY NSW 2000

Phone: 02 9377 2288  
Fax: 02 9377 2177  
Mobile: 0412 338 414

Email: Stephen.Harper@defence.gov.au

16 May 2008

*Defending Australia and its National  
Interests*

DSTO-GD-0559

## 2.1.3 Supplementary Instructions Number 2 – 18 August 2008

  
CORR.009.0010

HMAS SYDNEY II  
COMMISSION OF INQUIRY  
Office of the Chief of the Defence Force  
270 Pitt St  
Defence Plaza Sydney  
Sydney NSW 2000

**HMAS SYDNEY II COI/OUT/2008/**

**Ms Janis Cocking**  
Chief, Maritime Platforms Division  
Defence Science and Technology Organisation  
506 Lorimer Street  
FISHERMANS BEND VIC 3207

Dear Ms Cocking,

**SUPPLEMENTARY INSTRUCTIONS – NUMBER 2 – HMAS SYDNEY II**

1. Further to our initial letter of instruction dated 6 May 2008 and supplementary letter of instruction 16 May 2008. I am writing to request information that I suspect as a consequence of our meetings will be covered in your report in any event. Secondly, this letter sets out the assumptions that you are asked to make in coming to your expert opinion.

**Machinery**

2. Can you provide a brief overview of the machinery layout, commenting particularly upon:
- a. the machinery in each boiler room;
  - b. how the boilers supplied steam to each engine room;
  - c. the machinery in each engine room, in particular:
    - (1) the different turbines in each set (low pressure and astern turbine, a high pressure turbine and a cruising turbine);
    - (2) how these sets were coupled through gear cases to the four propeller shafts; and
    - (3) the combined total shaft horsepower.

1

DSTO-GD-0559

  
CORR.009.0011

- d. Redundancy systems, such as:
- (1) cross-connection of steam pipes; and
  - (2) gearing allowing one engine room to drive one or more propeller shafts;
    - a. Whether there was any disadvantage in SYDNEY's machinery layout, such as, in the form of a potential stability hazard. In this regard, you are invited to comment upon the comment by CAPT Peter Hore RN (Rtd)<sup>1</sup> that, "...if a torpedo explosion flooded both engine rooms, the after boiler room and one wing space, the asymmetric buoyancy of the remaining wing space would, with the loss of stability from three flooded compartments, cause very rapid capsize, perhaps in less than a minute. Though with hindsight this may be obvious, it would have been almost impossible, without a computer in the 1930s, to calculate such a condition"?

#### The Main Service and the Main Suction

3. It is understood that the systems for the delivery and removal of sea water and fresh water throughout SYDNEY were the Main Service and the Main Suction. Can you confirm that this is correct and provide a brief overview of these systems, commenting particularly upon:

- a. the delivery of water to different parts of the ship;
- b. the principal requirements for water throughout the ship (for example, operating machinery, sanitary services, deck cleaning, fire fighting, flooding of compartments to correct trim);
- c. the location, in general terms, in the ship of the pipes, pumps and other plant used for the delivery of water;
- d. the protection, if any, afforded to the pipes, pump and other plant used for the delivery of water by armour plating or other means;
- e. the removal of water from different parts of the ship;
- f. the principal reasons why water would need to be removed from the ship (for example, drainage, flooding and pumping out of spaces);

<sup>1</sup> Hore, P., CAPT, RN (Rtd), *HMAS SYDNEY: The Cruiser and the Controversy in the Archives of the United Kingdom*, RAN Sea Power Centre, 2001, p. 254-5. CAPT Hore was a logistics specialist with no engineering qualifications. He made that comment with the benefit of correspondence from a marine engineer and author on British Naval Ships, Mr D.K. Brown. The COI has sought a copy of that correspondence.



DSTO-GD-0559



- g. the location, in general terms, in the ship of the pipes, pumps and other plant used for the removal of water from the ship;
- h. What protection, if any, was afforded to the pipes, pump and other plant used for the removal of water by armour plating or other means; and
- i. the capacity for the cross-connection between the Main Service and the Main Suction to enable either system to be used for supplying or removing water from compartments?

#### **Fire Fighting**

- 4. Can you provide a description of the fire-fighting systems in SYDNEY? In particular, can you advise:
  - a. in general terms, where fire mains were located in the ship;
  - b. where hoses and nozzles were stowed in relation to the fire mains;
  - c. what, if any, other fire-fighting equipment was embarked, such as fire extinguishers and buckets of sand and where such equipment was stowed;
  - d. what provision was there for compartments to be:
    - (1) flooded; and/or
    - (2) sprayed

#### **Electrical System**

- 5. Can you provide a brief overview of the electrical system in SYDNEY, commenting particularly upon:
  - a. the main power system, including:
    - (1) how main power was generated;
    - (2) which machinery and systems in the ship were powered by main power;
    - (3) how and where the distribution of main power was controlled;
    - (4) what physical protection, if any, was provided to the main power system, including the Switchboard Room and other control spaces, by means of armour or other means;

3

DSTO-GD-0559

  
CORR.009.0013

- (5) what redundancy system or systems were available in respect of the main power system? In particular, what capacity was there for main power to be:
  - a. split into different circuits as a precaution against battle damage; and
  - b. isolated from damaged areas.
- b. the low-power system, including:
  - (1) how low power was generated;
  - (2) which machinery and systems in the ship were powered by low power;
  - (3) how and where the distribution of low power was controlled;
  - (4) what physical protection, if any, was provided to the low power system, including the Switchboard Room and other control spaces, by means of armour or other means;
  - (5) what redundancy system or systems were available in respect of the low power system? In particular, what capacity was there for main power to be:
    - a. split into different circuits as a precaution against battle damage; and
      - (1) Isolated from damaged areas;
      - (2) Backed-up by batteries; and
    - b. any emergency lighting systems. In particular, whether any spaces had emergency lighting systems and how did emergency lighting work?

#### **Boats and Carley Floats**

6. Can you provide an overview of the boats and floats in SYDNEY, commenting particularly upon:
  - a. the type, number and location on the ship of all boats;
  - b. the type, number and location on the ship of all Carley floats;
  - c. what life preservation stores and equipment was provided in these boats and floats;

4



- d. the manner in which these boats and floats were tied, lashed or otherwise fixed to the ship; and
- e. the manner in which these boats and floats would be made ready for use.

**Radio Telegraphy**

7. Can you advise whether SYDNEY was equipped with any equipment which enabled her to transmit voice messages and, if so:
- a. the type and location in the ship of such equipment; and
  - b. the capacity (in terms of range) of such equipment.

**Radio Direction Finding**

8. Can you advise whether SYDNEY was equipped with any equipment which enabled her to conduct Radio Direction Finding operations and, if so:
- a. the type and location in the ship of such equipment; and
  - b. the capacity (in terms of range) of such equipment.

**Distance to Horizon**

9. Could you advise the distance to the horizon in respect of:
- a. SYDNEY's bridge; and
  - b. SYDNEY's crow's nest?

**Signal Lamps**

10. In respect of signal lamps in SYDNEY, can you advise:
- a. the type, size and location in the ship;
  - b. the wattage; and
  - c. whether the Searchlights mounted on SYDNEY had the capacity to be used as a signal lamp?

DSTO-GD-0559



**Effective Range for Flags and Signal Lamps**

11. The COI is interested to learn the effective range for signaling by flags and by signal lamp.

- a. In relation to signaling by flag, if you assume optimum condition, namely:
  - (1) the signaling occurs in ideal light;
  - (2) visibility is excellent;
  - (3) the signal yards of both ships were sufficiently above the horizon; and
  - (4) the observer on each ship had visual aids such as binoculars and rangefinders
- b. what was the limit of effective range of signaling?
- c. In relation to signaling by signal lamp, if you assume optimum condition, namely:
  - (1) the signaling occurs in ideal light;
  - (2) visibility is excellent;
  - (3) the signal yards of both ships were sufficiently above the horizon; and
  - (4) the observer on each ship had visual aids such as binoculars and rangefinders
- d. what was the limit of effective range of signaling?

**Movements of the Executive Officer**

12. Assuming that:
- a. when SYDNEY went to Action Stations, the Executive Officer closed up in the Aft control position;
  - b. as part of going to Action Stations, all watertight doors and hatches were closed;
  - c. in the event that the bridge was out of action and the Executive Officer had to assume command of the ship, he would move to the Aft Control Position; and
  - d. the port side of the ship was under direct enemy fire

6



When the ship was at Action Stations, what was the shortest route from the Lower Steering Position to the After Control Position? If possible, please provide a diagram showing this route.

#### **Disposition of the Crew at Action Stations**

13. Part of your brief is to, as best you can, provide an opinion about the consequences for crew of the unfolding engagement involving HMAS SYDNEY and HSK KORMORAN on 19 November 1941. For that purpose, we annex:

- a. "HMAS SYDNEY - Casualty List – Missing Presumed Dead" (our ref: SPC.004.0222) (Annex A);
- b. "HMAS SYDNEY List of Personnel Amendments (29.11.41)" (SPC.004.0286) (Annex B);
- c. three tables setting out the officers and crew by category and service (based on a. and b. above) (Annex C); and
- d. a list of assumptions about the disposition of the crew at Action Stations (Annex D).

14. The three tables at Annex C are an interpretation of the original documents, "Casualty List – Missing Presumed Dead" and "List of Personnel Amendments (29.11.41)" (Annexes A and B) and to the extent that there is any inconsistency, the original documents should be preferred.

15. The list of assumptions is based on factual findings that appear available from evidence received by former crewmembers of SYDNEY. You are asked to make those assumptions for the purposes of providing your expert advice.

#### **Distances**

16. Please estimate the maximum distance that a vessel of approximately:
- a. 3,000 tonnes; and
  - b. 8,000 tonnes

Would be visible from the Crow's nest bridge of a major warship on a bright moonlit night.

DSTO-GD-0559



Please do not hesitate to contact me in relation to any of the matters raised in this correspondence.

A handwritten signature in black ink, appearing to read 'John T. Rush', is positioned above the typed name.

**John T. Rush, RFD QC**  
Commander RANR  
Senior Counsel Assisting  
HMAS SYDNEY II  
Commission of Inquiry

Phone: (02) 8239 5425  
Email: [john.rush@sydneyii.com.au](mailto:john.rush@sydneyii.com.au)

18 Aug 08

**Annexes:**

- A. HMAS SYDNEY - Casualty List -- Missing Presumed Dead SPC.004.0222
- B. HMAS SYDNEY List of Personnel Amendments (29.11.41) SPC.004.0286
- C. HMAS SYDNEY II Casualties Table
- D. List of Assumptions about the Disposition of the Crew at Action Stations

## 1.2 Scientific Approach

In the provision of expert advice and opinion, DSTO and RINA have used a number of scientific analysis tools. Aside from the physical examination of the video imagery, and a large quantity of historical documents, photographs and other publications, the analysis utilised modern computer codes. The details of the computer codes are outlined below together with any validation or verification of the models used. The underwater images used in this report were supplied by the Finding Sydney Foundation. The only modification made to them was that they were processed using an underwater correction filter in Adobe Photoshop. This process replaces the red wavelength lost due to absorption of red light underwater.

### 1.2.1 Vulnerability Analysis

The vulnerability assessment method (XVAM) is based on empirically-based blast and fragment damage algorithms to calculate the extent of damage throughout a structure. XVAM is useful in identifying regions of concern or vulnerable areas within the ship design. The XVAM methodology is used to map the damage originating from a detonation point. It calculates a probability of failure occurring for the systems, personnel and structure within the damage zone resulting from the detonation of a conventional warhead. The simulation provides a statistical measure of the likelihood an event will occur, rather than an accurate measure of the failure mechanism incurred. The code was validated against full-scale weapons effects trials including those on the decommissioned HMAS Derwent.

DSTO has previously used XVAM vulnerability assessment methodology to conduct studies of the vulnerability of a number of ships, including the Anzac class frigates and Mine-hunter coastal vessels to weapons effects. XVAM has also been used in the study of the effectiveness of a number of weapons against warships.

For realistic assessments to be conducted, information on both the structural detail and the system equipment distribution are required. Structural detail includes compartment layout, as per the general arrangement drawings, bulkhead, hull, and decking information such as material type, stiffener layout, ballistic protection, and edge restraints.

#### 1.2.1.1.1 *Sydney* model for XVAM analysis

A representative model of *Sydney* used in the XVAM analysis was developed based on the general arrangement drawings [1-7] Each bulkhead was assigned a metal thickness extracted from the armour and protective plating drawing [5], the longitudinal plating drawings [8], [9] and the hull shell plate drawing [10]. The thicknesses of internal bulkheads not recorded on *Sydney* drawings were assigned a value of 10 mm to 20 mm based on best case scenario for the location of the bulkhead, to allow the code to trace the likely effects of fragment penetration into adjacent compartments. The representative model developed for the analysis is shown in Figure 1.

DSTO-GD-0559

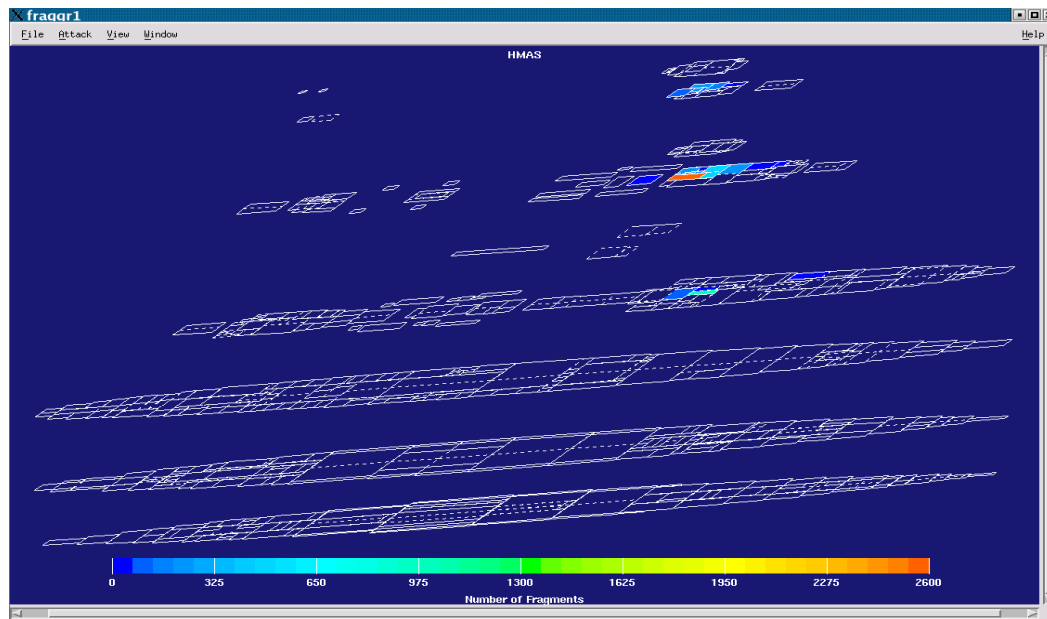

Figure 1: XVAM model of Sydney

## 1.2.2 Flooding Analysis

The flooding analysis used two codes, FREDYN [11] and PARAMARINE [12]. FREDYN is a time domain numerical tool that predicts the motions of a ship in moderate to extreme seaways. These motions incorporate both small and large amplitude motions including broaching and capsizing. Recently the capability of FREDYN has been extended to predict the progressive flooding of a damaged ship and the implications this flooding has on the overall motions and stability of the vessel in the ocean. Estimates of time to sink or capsize can be determined.

### 1.2.2.1 Flooding Methodology

Progressive flooding is dependent upon the internal ship geometry, including openings such as doors, hatches and ducts. For any FREDYN simulation of the dynamic stability of a damaged ship, a compartment model is generated which includes details such as: (a) compartment boundaries, (b) openings, (c) liquid densities, (d) initial fluid volumes and (e) compartment permeability.

The flooding module within FREDYN is based on the Bernoulli equation for fluid and gas flow. Hence, compressibility of air is taken into account. These equations are applied to each of the openings and/or ducts connecting adjacent compartments and assume stationary flow conditions and no loss in energy due to friction. The velocity of flow through openings is determined by considering the difference in pressure heads in neighbouring compartments or the compartment and the open sea. The total discharge through a hole is determined by considering the size of the hole and a discharge coefficient.

Based on the computed inflow and outflow of the fluid through the openings, the fluid volume, hence mass, inside each compartment is known at each time-step. The fluid surface



inside each compartment is assumed to be horizontal. The influence of the mass of the fluid at each time-step is then considered and a new equilibrium position of the vessel is calculated. Updating of this new vessel position leads to the recalculation of the fluid heights within the compartments and hence flow velocities through the openings. The fluid and airflow equations are iteratively solved at each time-step.

The inputs to FREDYN are generated in PARAMARINE and exported into FREDYN.

#### 1.2.2.1.1 Numerical model preparation

Figure 2 shows the compartment model of *Sydney* that was generated in PARAMARINE. The compartments shown in yellow are those compartments that potentially can be flooded due to the identified damage. All compartments are assumed to be empty.

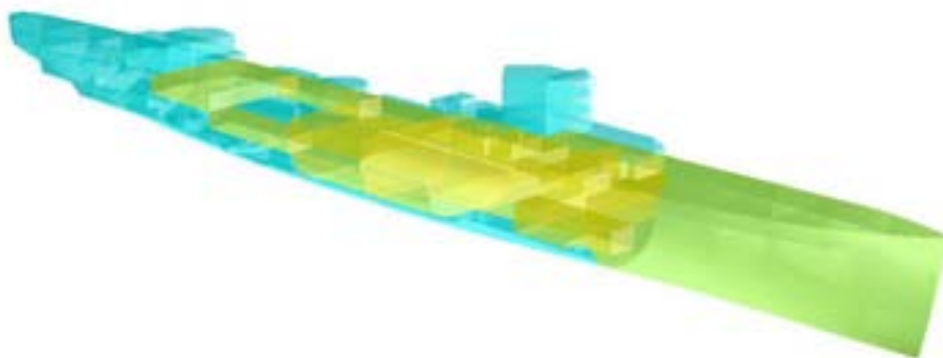

Figure 2: Numerical model of Sydney

#### 1.2.2.1.2 Hydrostatics

To ensure accuracy of the numerical model, the calculated mean draught value was compared to that obtained from HMS AMPHION's metacentric diagram. Other relevant hydrostatic data was obtained from *Amphion* hydrostatic curves and the modified Leander metacentric diagram. The *Amphion* Hydrostatic Curves are shown in Figure 3, the Leander metacentric diagram is shown in Figure 4 and *Sydney's* metacentric diagram is shown in Figure 5. Other vessel particulars used are shown in Table 1.

DSTO-GD-0559

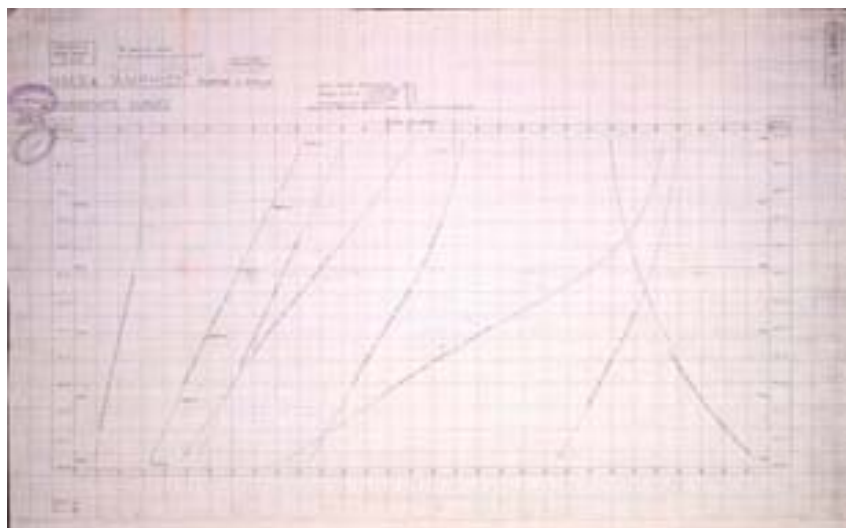

Figure 3: HMS Amphion Hydrostatic Curves [13]

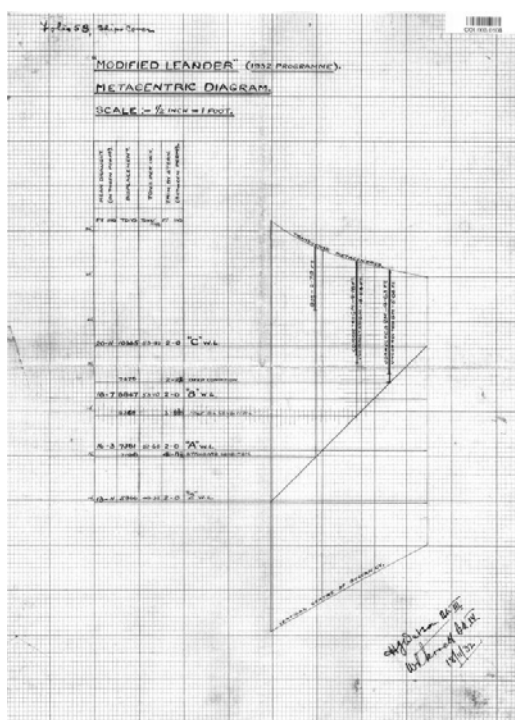

Figure 4: Modified Leander Metacentric Diagrams [14]

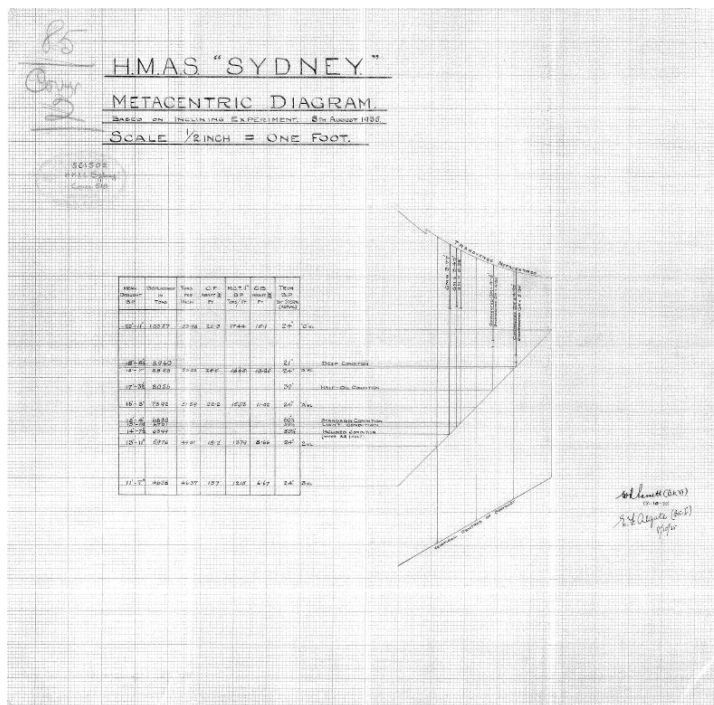

Figure 5: Sydney Metacentric Diagram [15]

Table 1: Sydney Vessel Particulars

| Vessel Particulars | Value |
|--------------------|-------|
| Displ (tons)       | 7510  |
| LCG (m) from AP    | 73.72 |
| KG (m)             | 6.51  |
| GM (m)             | 0.63  |

Based on the vessel particulars in Table 1 the mean draught calculated for Sydney was 4.8 m compared to 4.95 m as shown on the metacentric diagrams. The calculated trim of the vessel was slightly different to the values shown on the hydrostatic curves but as the actual loading condition at the time of the battle is unknown it has been assumed that the calculated values are reasonable. The calculated draught values and those extracted from the metacentric diagrams are shown in Table 2.

Table 2: Comparison between provided and calculated draughts

| Parameter            | Value from Metacentric Diagram | Calculated |
|----------------------|--------------------------------|------------|
| T <sub>mid</sub> (m) | 4.95                           | 4.80       |
| T <sub>AP</sub> (m)  | 5.26                           | 5.56       |
| T <sub>FP</sub> (m)  | 4.65                           | 4.05       |

DSTO-GD-0559

Thus it can be concluded that the PARAMARINE model behaves in a similar fashion to that expected for *Sydney*. Furthermore, since the FREDYN model is exported from the PARAMARINE model it is therefore also believed to be valid.

### 1.2.3 Seakeeping Loads Analysis

The software code, PRECAL (Pressure Calculations) was used to determine the magnitude of the loads experienced by *Sydney*. PRECAL is a 3-dimensional linear structural responses and *seakeeping* code, which uses an advanced three dimensional panel method to calculate the pressures due to seawater acting on individual elements of a mesh representing the hull surface of a ship [16].

#### 1.2.3.1 Model Development

In order to create the mesh geometry of *Sydney* hull, the body plan [17] shown in Figure 6, was imported into the 3D CAD (Computer Aided Drafting) software Rhinoceros [18].

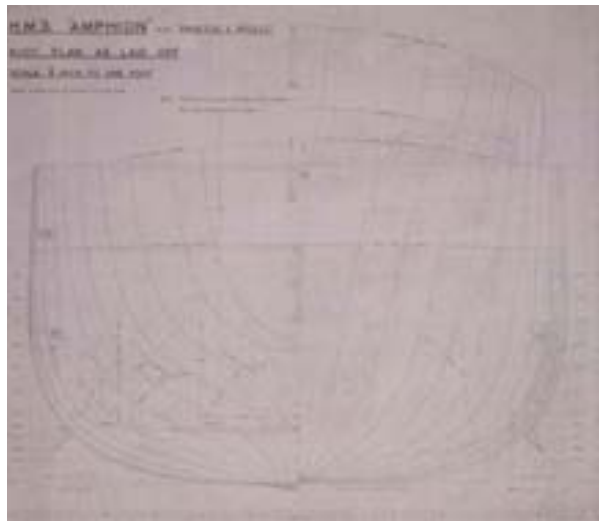

Figure 6: Original LEANDER class Body Plan [17] used for mesh generation

Rhinoceros[18] was then used to create a three-dimensional set of coordinates of the hull surface that could be used by the automatic mesh generator to generate the underwater hull mesh shown in Figure 7.

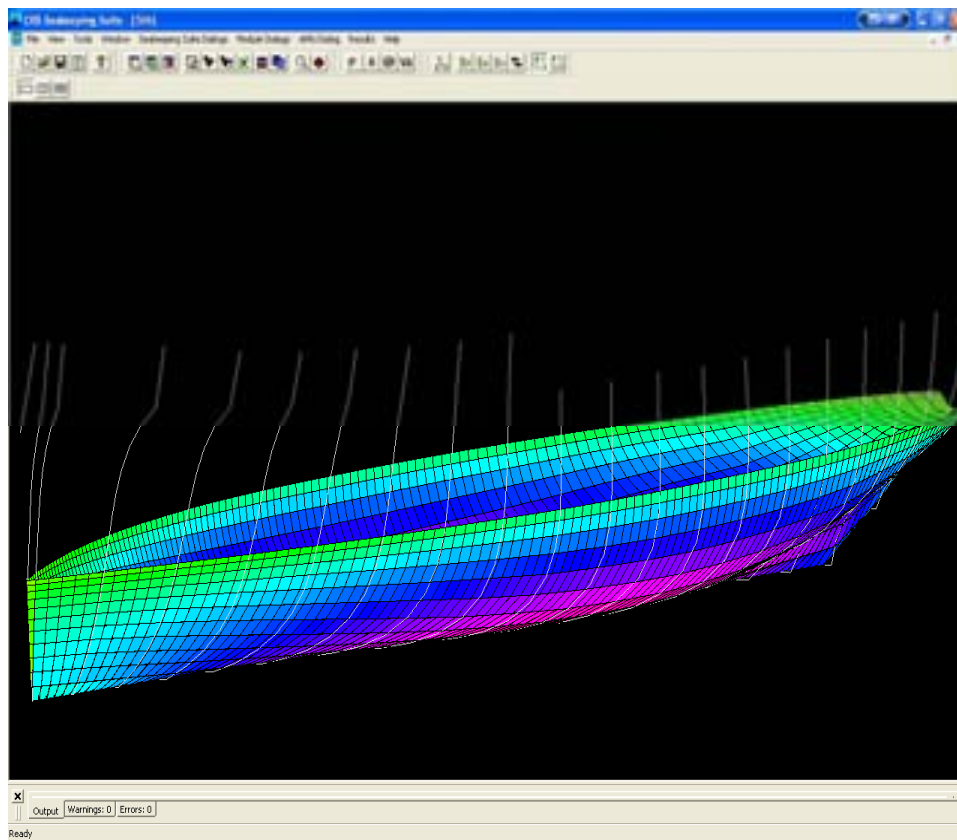

Figure 7: 3D mesh used to validate PRECAL Sydney model

The first mesh created for *Sydney* was for the vessel floating at her design displacement and trim so that confidence in the application of the PRECAL software to the analysis could be established. A typical method of establishing this confidence is to replicate the results of a previous analysis. Original design calculations for the longitudinal strength [19] and hydrostatics [20] of *Sydney* were available from the national archives, which could be used for this purpose.

To replicate the longitudinal strength calculations, PRECAL was set up to calculate the bending moments along the length of the vessel in regular (i.e. sinusoidal) waves on a headseas direction. The waves were of a wavelength equal to the length between perpendiculars of *Sydney*, with a waveheight of the length between perpendiculars divided by 20, in line with standard practice at the time *Sydney* was designed [21]. The results of the PRECAL analysis are shown in Figure 8 using the original design calculations as a background.

DSTO-GD-0559

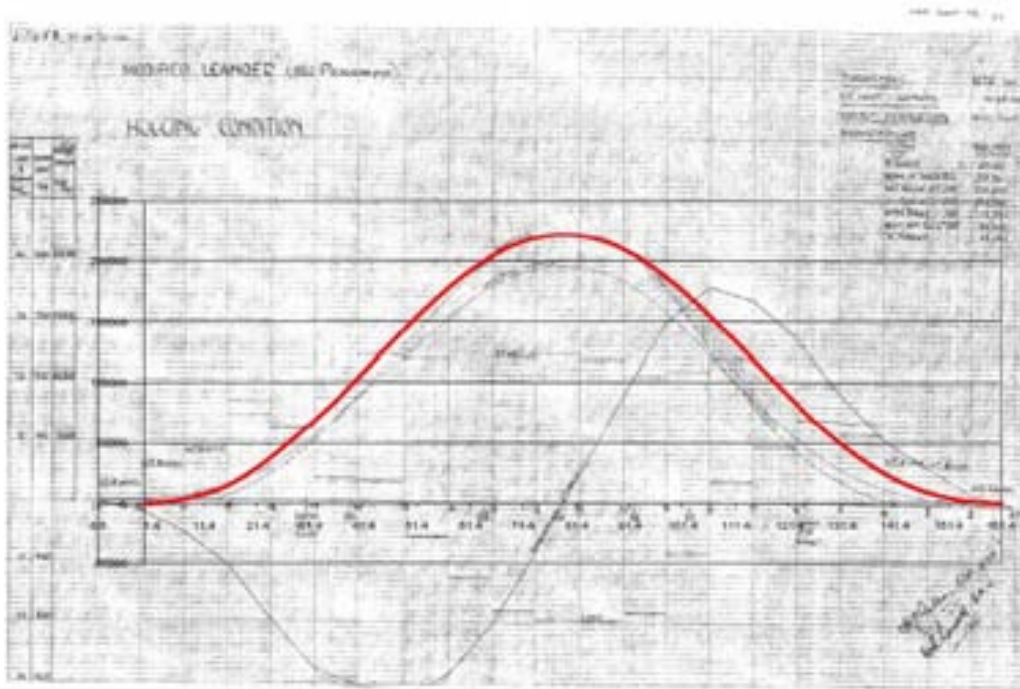

Figure 8: PRECAL (red) and Original Design longitudinal strength comparison. (Both results are plotted at the same scale) [19]

The comparison shows PRECAL results within 10% of the original design calculations, which not only gives confidence in the PRECAL model, but also displays the proficiency of the Naval Architects that performed the original calculations over 70 years ago. The still water hydrostatics for *Sydney* output from PRECAL has been compared with the design hydrostatics at the same displacement in Table 3.

Table 3: Hydrostatics Comparison

|              | PRECAL  | Curves |
|--------------|---------|--------|
| Displ (tons) | 7708.63 |        |
| LCF (ft)     | -25.33  | -23.8  |
| BMt (ft)     | 14.64   | 15.1   |
| KB (ft)      | 9.98    | 9.81   |
| KMt (ft)     | 24.62   | 24.95  |
| LCB (ft)     | -15.78  | -11.9  |

Again, good levels of correlation are displayed between the design and PRECAL calculations. This correlation led to confidence in the use of PRECAL in the analysis of the longitudinal strength of *Sydney*.

## 1.2.4 Structural Integrity Analysis

The software code, ULTSTR (Ultimate Strength) was used for calculating the ductile collapse (ultimate) strength at a section of a surface ship. It is based on a variety of empirically based strength of material solutions for the most probable failure modes for unstiffened and stiffened plate structures [22].

### 1.2.4.1 Model Development

ROV footage analysis from the *Geosounder* expedition identified that there was visible damage caused by a torpedo hit on *Sydney* at approximately frame 27 (see description of evidence from the wreck site in Chapter 6). The geometry and longitudinal stiffener arrangement of frame 27 was input using the sections design drawing [23], shown in Figure 9a. The shell expansion [24] was used for the outer shell plating thicknesses and the ULTSTR model set up using a combination of stiffened panels and hard corners. The ULTSTR model of frame 27 is shown in Figure 9b.

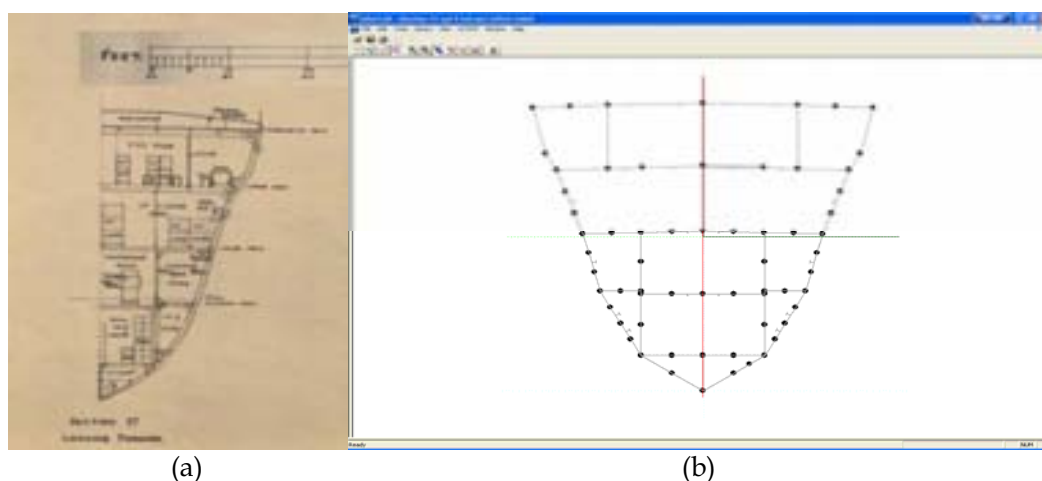

Figure 9: Frame 27 arrangement (a) and ULTSTR model (b)

Commensurate with the design practices at the time of *Sydney's* construction, ultimate strength of the hull girder was unlikely to be calculated, hence, comparisons with design data are impossible. However, during a literature review on the subject of ultimate hull girder strength, hull girder cross section area data was found that provides a useful comparison to validate the ultimate strength results for *Sydney* [25], which can be seen in Table 4.

Table 4: Comparison of Hull Girder Cross Section Areas

| Ship                   | ALBUERA (amidships) | SYDNEY (fr 27) |
|------------------------|---------------------|----------------|
| $L_{pp}$ (ft)          | 355                 | 530            |
| CSA (in <sup>2</sup> ) | 1057.64             | 1330.95        |

From Table 4, using engineering judgement, it can be seen that the hull girder section area of *Sydney* corresponds well with that of the surplus destroyer ALBUERA. This is due to the midship section area of ALBUERA not considering the vessels superstructure [25] and frame

DSTO-GD-0559

27 of *Sydney* being located in the finer, forward section of the ship. In addition, *Sydney* is 200' longer than ALBUERA. Therefore it is considered reasonable that the structural model of *Sydney* is valid. Confidence has been established in the PRECAL and ULTSTR models used in the structural analysis. The hydrostatics and bending moments calculated using PRECAL show good levels of correlation with the original design calculations for *Sydney*. The section properties calculated using ULTSTR agree with previous work.

### 1.2.5 Visualisation

Because *Sydney* was a very complex structure, and one which is not representative of current naval vessel configurations, there was a considerable risk that the conclusions drawn from the various analyses may be very difficult to describe or illustrate in a concise, readily understood form. For this reason it was decided to develop a high-fidelity, computer-based model of the ship. The aim was for the model to be used (a) to image particular locations on the ship, (b) to undertake 'forensic visualisations' of the vessel (for instance investigating the interaction of potential shell trajectories with the vessel) and (c) to generate realistic animated visualisations of critical phases of the engagement between the two vessels.

The three-dimensional visualisation package 'Blender' was selected for use [26]. This is open-source software which benefits from having a very active user and developer base. While Blender is not an engineering drawing or development package, it can support development of three-dimensional models which are both precise and of high-fidelity. In the first instance general arrangement drawings of *Sydney* were imported into the Blender development environment. Three dimensional meshes of the ship's major structures were built from these plans. In many instances, the plans were not sufficiently detailed to enable components of the ship to be built. In these cases it was frequently possible to refer to photographs taken of the ship itself, or to photographs that are available from museum and manufacturer's archives. In some cases second-world war reference manuals are available which include detailed drawings.

There are quite a few inconsistencies between the ship's configuration as shown on plans and what photographs and other sources of information indicate her 1941 configuration may have been. As far as it has been possible to achieve, the modelled ship's configuration is as it existed in late 1941.

The Blender package allows components and whole structures to be moved, rotated and altered, either statically or as an animated sequence. Virtual cameras and lighting can be applied to the modelled structures. The visualisations that are included in this document have been generated with the aim to allow the viewer to appreciate or understand a particular message. There is no particular 'message' in the direction of shadowing as included in the images. Shadowing is simply being used as a tool to help the viewer interpret the structures in three dimensional space.

### 1.2.6 Computer Aided Design (CAD) Modelling

As part of the Damage Survey rough estimates were provided for the size of damage to *Sydney*. This was done using the CAD package Rhinoceros [18]. Using this package it was



DSTO-GD-0559

possible to overlay a grid over the ROV images and use this grid to estimate the size of features in the photos.

The process used involved identifying features in the photograph of known size and then overlaying a grid over the photograph based on these dimensions (see Figure 10). This grid was then used to estimate the size of the feature. It is expected that these measurements have accuracy in order of  $\pm 50$  mm. The measurements from these photographs are given in imperial units to be consistent with the original drawings of Sydney.

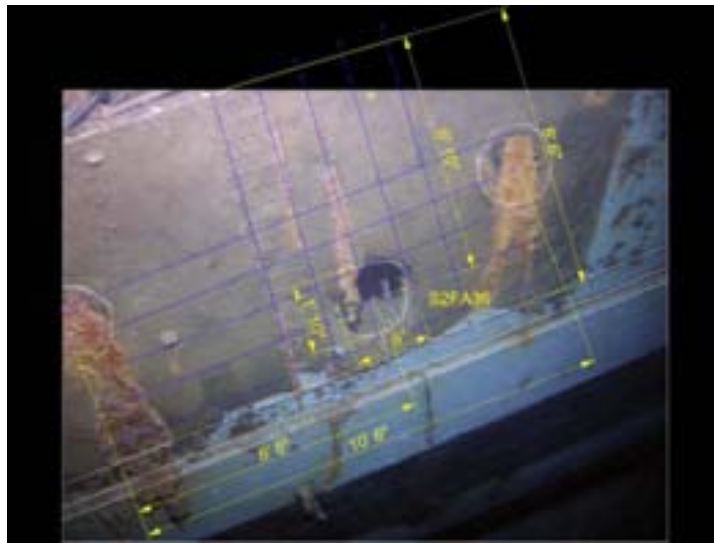

Figure 10: Image of Sydney showing CAD overlay used to take measurements [27]

A similar process was also used to make accurate measurements of features on *Sydney* that were not scaled from the profile and General Arrangement (GA) drawings [1].

It should be noted that these measurements are provided only as a guide to the size of the damage in *Sydney*. It was important to obtain an idea of the size of the damage in order to classify likely causes. This is particularly relevant when using the ROV footage which can provide a distorted indication of size as a consequence of the effects associated with its limited field of view.

### 1.2.7 Fire Assessment

Many examples of fire damaged ships are available. Some of these have been used as reference material to assist in the identification of fire damage to Sydney. These are described below.

Often fire damage to painted steel is accompanied by corrosion which will also occur where metal has been damaged from fragments. Corrosion can grow into rusticles due to the action of micro organisms in the sea and these are often used as evidence of fire damage. In some

DSTO-GD-0559

locations it is difficult to distinguish corrosion due to organisms from corrosion due to fire damage.

#### 1.2.7.1.1 Admiral Graf Spee, 1939

The German pocket battleship *Admiral Graf Spee* (Figure 11 to Figure 13) was involved in the Battle of the River Plate in December 1939. The damaged ship withdrew to Montevideo. Three days later, the ship was taken out of harbour and scuttled in shallow water. The scuttling charges caused a large fire on the ship [28].

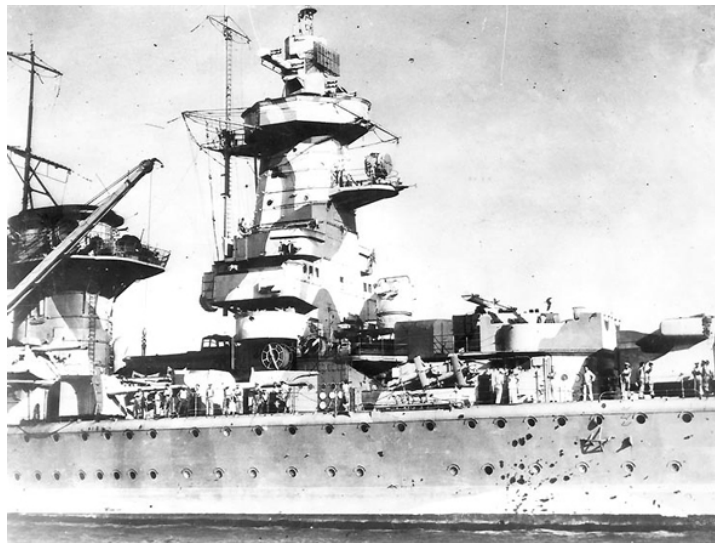

Figure 11: Bridge structure of Admiral Graf Spee following the Battle of the River Plate [29]

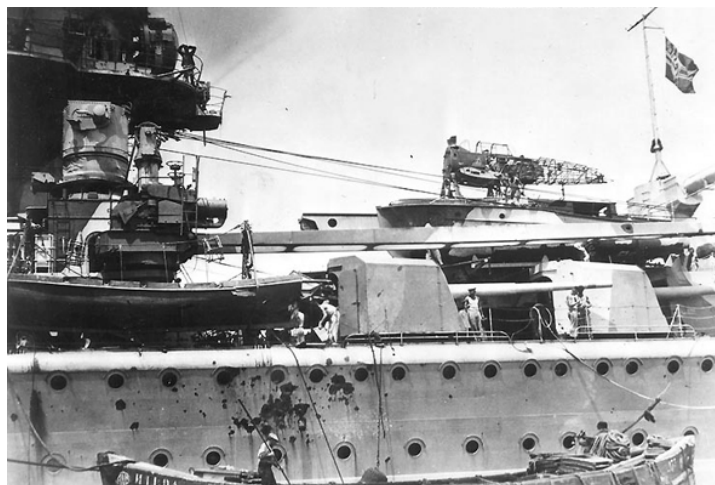
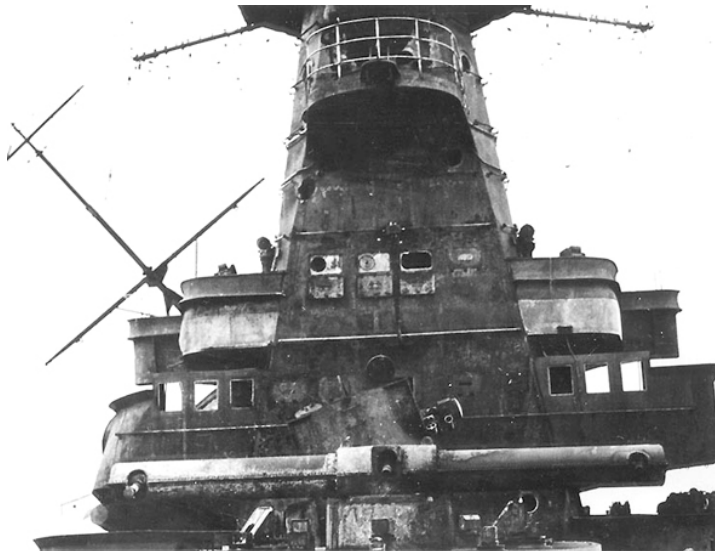

Figure 12: Burnt aircraft on Admiral Graf Spee, after the Battle of the River Plate [29]

DSTO-GD-0559



*Figure 13: The Admiral Graf Spee burning after scuttling charges had been detonated [30]*



*Figure 14: Bridge structure of Admiral Graf Spee following the fire [29]*

#### 1.2.7.1.2 HMS Sheffield, 1982

HMS *Sheffield* (Figure 15 and Figure 16), a destroyer, was hit by a missile on 4 May 1982 during the Falklands War. A large fire was started and could not be brought under control, forcing the crew to abandon ship [31].

DSTO-GD-0559



Figure 15: *Sheffield* prior to fire damage [32]



Figure 16: Fire damage to *Sheffield* [33]

#### 1.2.7.1.3 Royal Fleet Auxiliary (RFA) *Sir Galahad*, 1982

R.F.A. *Sir Galahad* was hit by bombs dropped from aircraft on 8 June 1982, during the Falklands War. This started a large fire, and the crew abandoned the ship [34]. The exterior damage to the ship can be seen in Figure 17.



Figure 17: Fire damage to Sir Galahad [35]

#### 1.2.7.1.4 HMAS Westralia, 1998

A fire in the engine room of HMAS *Westralia* caused by diesel leaking from a fuel line on an engine occurred on 5 May 1998. The spray fire impinged against a bulkhead adjacent to the engine, causing damage to paint and materials attached to it. A computer-based fire simulation was carried out, and the results matched the damage observed [36], this is illustrated in Figure 18.

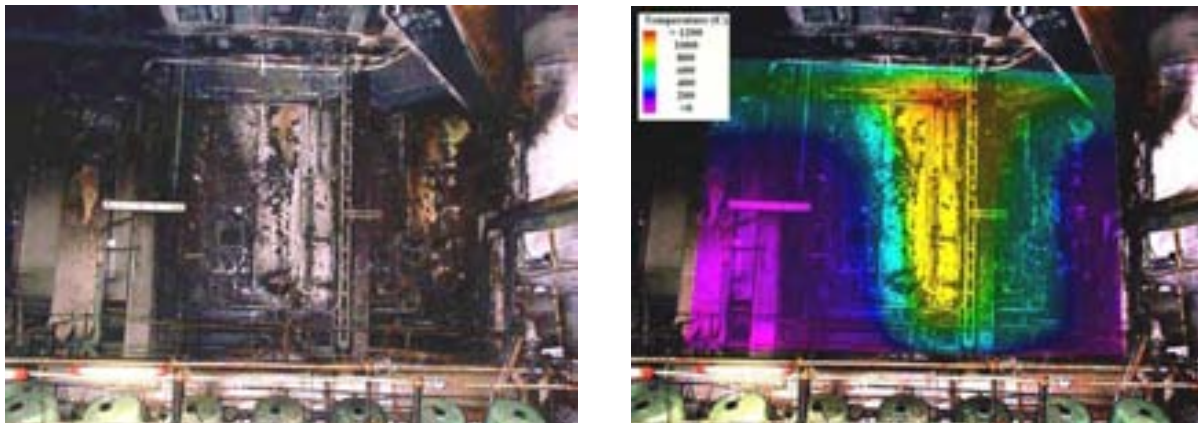

Figure 18: Damage to a bulkhead adjacent fire and fire simulation results overlaid on the damage

#### 1.2.7.1.5 Superferry 14, 2004

A terrorist bomb exploded on *Superferry 14* in February 2004, igniting a fire [37]. Photographs after the fire, as displayed in Figure 19, show the damage to the ship [38]. Paint can be seen burnt through to the undercoat and the steel structure in places.

DSTO-GD-0559



Figure 19: Fire damage to Superferry 14 [38]

#### 1.2.7.2 Fire spread

Fires on ships have the potential to spread if not controlled. Heat from a fire in a compartment can be conducted through steel bulkheads and decks, and ignite combustible materials in neighbouring compartments. This has occurred on ships which have suffered weapon damage including HMS Sheffield (1982) and U.S.S. Stark (1987) [39, 40], which were both hit by missiles. Damage to firemain, loss of crew, difficulties due to smoke, and time to assess damage provides time for heat from fires to transfer to other compartments and so spreads the fire. This has been studied on Ex HMAS Derwent in 1994, where a fire was set in a large sleeping space, designed to simulate a fire after a missile hit [41]. Heat from the fire was able to transfer through a bulkhead to the compartment forward of the fire compartment and burn the paint and fittings on the bulkhead of that space within an hour.

Modern ships may require fire insulation to be fitted to decks and deckheads. This is required for passenger ships under International Maritime Organisation regulations [42]. Fire insulation slows the transfer of heat from a fire to neighbouring compartments, providing more time for damage control crews to repair or configure firemain and hoses for fire fighting.

### 1.2.7.3 Examples of fire fighting in damaged ships

#### 1.2.7.3.1 HMS Arethusa, 1942

HMS *Arethusa* (cruiser, completed 1935) was hit by a torpedo below B turret in November 1942 [43, 44]. The torpedo explosion ignited a large fire from the 'Upper deck' to the 'bridge' from B turret to the aft of the bridge superstructure. The fire was initially fuelled from oil from a damaged tank thrown over the superstructure by the explosion. The explosion also damaged the Firemain forward of the machinery spaces, and it was not useable, so that fire hoses had to be run from the Firemain in the midships region. Prior to the incident, the Firemain was sub-divided into three sections with all pumps running, and it was planned to reduce the number of pumps to one per Firemain section as per night procedures. Electrical power supplies were interrupted resulting in one fire pump running after the explosion. All other pumps were operational within half an hour, some being fed by emergency electrical leads.

The fire was fought with water hoses run from the Firemain, foam with hoses run from a foam generator, and 'Foamite' fire extinguishers. The torpedo hit occurred at 6.05 PM, the fire was under control by midnight, and extinguished by daylight the next day.

Concern was initially held for the forward magazines, and the Upper deck flooding valve controls had jammed. However, it was discovered that these compartments were either damaged and flooded or surrounded by flood water, and so unlikely to be affected by the fire.

It was noted that the ship's course was the best for preventing the fire from spreading. This was fortunate as the ship had navigational and internal communications difficulties due to the damage.

#### 1.2.7.3.2 HMS Liverpool, 1940

HMS *Liverpool* (Southampton class cruiser) was hit by a torpedo forward of 'A' turret in October 1940 [45]. The explosion damaged the petrol storage tank of 5700 gallons, releasing petrol and fumes. While no fires were found, the forward magazines were flooded as a precaution. Approximately 35 minutes after the torpedo hit, the petrol fumes were ignited by an electrical short, causing an explosion and fire. The petrol explosion occurred at 7.20pm and fire fighting continued through the night. The intact bulkhead aft of the fire was (boundary) cooled to prevent the fire spreading aft. The ship went astern to reduce the likelihood of fire spreading aft (air movement along the ship would then not have been from the bow).

DSTO-GD-0559

#### 1.2.7.3.3 HMS Southampton, 1941

HMS *Southampton* (Southampton class cruiser) was hit by 500 pound bombs dropped by aircraft in January 1941 [46]. The firemain (which was damaged), was supplied by only one pump. This could not provide sufficient water pressure for fire hoses so fires could not be fought effectively. All of the magazines were flooded, to prevent heat effects on munitions, except those where the flooding valves were inaccessible due to fire. The spread of fire eventually caused the ship to be abandoned.

#### 1.2.7.3.4 HMAS Australia, 1945

HMAS *Australia* was struck by five Japanese aircraft between the 5<sup>th</sup> and 9<sup>th</sup> January 1945 [47]. In two of these instances fuel from the aircraft was ignited forming a fire on deck. Among the combustible materials paint on the superstructure burnt. It is stated that at the time the Firemain was isolated into several sections and all the Firemain pumps were running. The Firemain isolation valves were opened to provide maximum Firemain pressure for the hose teams on deck. The use of a 'Lux' CO<sub>2</sub> extinguisher was also described in the extinguishment of an electrical fire. It was stated that the use of recently acquired fire fighting equipment, notably new types of hoses with screw fittings, improved the performance of fire fighting efforts.

#### 1.2.7.3.5 HMS Birmingham, 1943

HMS *Birmingham* (Southampton class cruiser, completed in 1937) was struck by a torpedo forward of A turret on 28 November 1943 [48]. Prior to the incident, the Firemain was divided into two sections, each being supplied by a 50 ton (per hour) pump. Although a fire did not eventuate on this occasion it demonstrates the damage control procedure for eliminating a single point of failure by creating redundancy in fire fighting equipment.

#### 1.2.7.3.6 HMAS Hobart, 1943

HMAS *Hobart* (Modified Leander class cruiser) was struck by a torpedo aft of Y turret on 20 July 1943 [49]. Prior to the incident, the Firemain was divided into three sections. The forward section was supplied by a fire and bilge pump in the forward engine room, the mid section was supplied by a fire and bilge pump in 'B' boiler room, and the aft section was supplied by a fire and bilge pump in the aft engine room. The loss of the high power electrical system after the blast meant the loss of all fire and bilge pumps. While electrical power was restored within four minutes, the damage report recommends two of the eight fire and bilge pumps being steam driven in case of loss of electrical power. No fires were started from the torpedo hit, despite an oil tank being ruptured by the blast. A small electrical fire occurred later when an emergency electrical cable shorted to a deckhead which ignited 'the overhead cork dusting'. This fire was extinguished with a 'Simplex' portable fire extinguisher.



#### 1.2.7.4 Examples of smoke and toxic gas in damaged ships

##### 1.2.7.4.1 HMS Birmingham, 1943

*Birmingham* was struck by a torpedo forward of A turret on 28<sup>th</sup> November 1943. After the explosion, it was noted by the crew that toxic gas was present in the ship, particularly in the Forecastle and mess decks. It is stated that 45 crew were rendered unconscious from gas suffocation. Comments from British Admiralty confirm that toxic gases were produced during the detonation of explosives, and that they consisted of carbon monoxide and/or nitrous fumes [48].

##### 1.2.7.4.2 HMAS Australia, 1945

*Australia* was struck by five Japanese aircraft between the 5<sup>th</sup> and 9<sup>th</sup> January 1945. In the first attack, the aircraft crashed on deck and fuel ignited. Ventilation inlets close to this fire, from the switchboard room and the forward engine room, caused these spaces to be filled with smoke. The fire was extinguished quickly, resulting in those compartments not requiring to be evacuated.

In the second attack, the aircraft crashed on deck and a fuel fire was ignited. The ventilation to 'A' boiler room was shut down for a period to prevent 'smoke and flame' from being introduced to the compartment, while the fire was extinguished. The ship was turned to reduce intake of smoke into below deck compartments.

In the fourth attack no fire occurred but fuel from the aircraft was sprayed over the deck. Fuel vapour was quickly drawn into the ship via the ventilation system, requiring all ventilation in the forward of the ship to be stopped until the deck was washed.

The damage report recommends breathing apparatus be supplied for all crew in engine and boiler room, and the switchboard room. This would enable crew to remain in place in case of upper deck fires and smoke being drawn into these compartments by the ventilation system [47].

##### 1.2.7.4.3 Ex HMAS Derwent, 1994

A series of experiments were undertaken on the Ex HMAS *Derwent* in 1994 [41], including fire and smoke experiments, Figure 20. A fire designed to simulate a fire after a missile hit was set in a large sleeping space, Figure 21, and spread to neighbouring compartments. The ship was tied at the bow, and able to pivot with the wind, which was therefore along the line of the ship. The smoke from the fire moved through openings in the ship to the upper decks, and along the ship with the wind. The obscuration of the ship's structure shown in Figure 22 is an indication of the thickness of the smoke.

DSTO-GD-0559



Figure 20: Ex HMAS Derwent

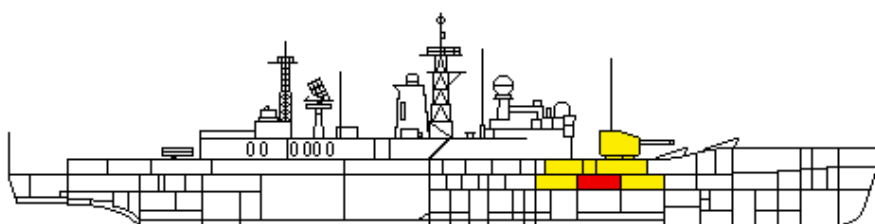

Figure 21: Fire originated in red compartment, and spread to yellow compartments



Figure 22: Smoke obscuring ship

#### 1.2.7.4.4 Superferry 14, 2004

A terrorist bomb exploded on *Superferry 14* in February 2004, igniting a fire [38]. Photographs taken during the fire, displayed as Figure 23 show the smoke produced [37].



Figure 23: *Superferry 14* fire [37]

#### 1.2.7.4.5 HMS Sheffield, 1982

*Sheffield* was hit by an air-launched Exocet missile on 4 May 1982, during the Falklands war. A large fire on the ship was ignited [50], as shown in Figure 24, Figure 25 and Figure 26. The Figures show the impact of changing the ship's heading relative to the wind on the smoke over the ship.



Figure 24: *Smoke from Sheffield* [51]

DSTO-GD-0559



Figure 25: Smoke from Sheffield [52]



Figure 26: Smoke from Sheffield [53]

#### 1.2.7.4.6 Rusticles

'Rusticles' removed from RMS *Titanic* contain bacteria which consume components of the steel structure (the ship is deteriorating through physical and biological effects) [54]. Table 5 provides a comparison of the presence of rusticles in other ships lost in about the same time period as *Sydney* together with the condition of the *Titanic* which was lost 30 years earlier. Images of rusticles on *Titanic* are shown in Figure 27.

DSTO-GD-0559

Table 5: Deterioration - comparison with other wrecks

| Ship          | Sunk | Location             | Approximate depth (m) | Condition   |
|---------------|------|----------------------|-----------------------|---|
| Titanic [55]  | 1912 | West Atlantic ocean  | 3800                  | Extensive rusticle formations   |
| Hood [56]     | 1941 | North Atlantic ocean | 2700                  | Paintwork generally in good condition, some corrosion, some rusticle formations   |
| Bismarck [56] | 1941 | East Atlantic ocean  | 4700                  | Paintwork generally in good condition, corrosion is heavy where fire has removed or damaged paint, some rusticle formations |
| <i>Sydney</i> | 1941 | East Indian ocean    | 2500                  |   |



Figure 27: Rusticle formations on Titanic [57]

## 2. HMAS Sydney Design

### 2.1 Overview

*Sydney* was a Modified Leander Class light cruiser, one of three originally ordered for the Royal Navy. The three cruisers, *Phaeton*, *Amphion* and *Apollo*, were all to serve in the RAN as HMA Ships *Sydney*, *Perth* and *Hobart*. *Phaeton* was the first to be completed, as *Sydney*.

The Modified Leander Class cruisers were designed by the Admiralty under the supervision of the Director of Naval Construction, Sir Arthur Johns KCB CBE RCNC. The Constructor responsible for the design was the distinguished naval architect Charles Lillicrap<sup>1</sup> who was head of the cruiser section at the time. Lillicrap was also responsible for the design of the highly-regarded County-class cruisers (including the RAN heavy cruisers *Australia* and *Canberra*) and the ships of which the Modified Leanders were a development – the Leander Class light cruisers. Drawings of the profile and each of the decks of *Sydney* are provided in Figure 30 to Figure 36. These drawings are tracings of the original as fitted plans [1-4, 6, 7, 58]. The original drawings have been included in Appendix 2.

#### 3.1.1 Design Origin

British cruiser design and construction during the 1920s and 1930s was dominated by the obligations imposed by the Washington Treaty of 1924 which limited cruisers to a standard displacement of 10,000 tons and guns not exceeding 8" calibre. The County-class cruisers were designed to these limits, but they were expensive ships and the Royal Navy could not afford to build sufficient ships of this type to satisfy the need for cruisers, estimated to be about 70 ships. A smaller ship (HMS *York*) was ordered in 1927, fitted with six rather than eight 8" guns and a sister ship (HMS *Exeter*) was ordered a year later [59].

Further designs of slower and smaller ships fitted with 8" or 6" guns were considered, and in 1927 the Admiralty approved the design of a cruiser fitted with eight 6" guns on a standard displacement of 7,154 tons. This ship became HMS *Leander*, ordered in the 1929 program.

---

<sup>1</sup> Sir Charles S. Lillicrap KCB MBE DSc RCNC (1887–1966). Director of Naval Construction 1944–1951. Also awarded the Legion d'Honneur and Grand Officer of the Order of Orange Nassau.



Figure 28: *S Ajax*, the last of the Leander Class cruisers to be completed (in April 1935) [60]

Charles Lillicrap was a great believer in the use of welding for ship construction, and the new design incorporated welding where he believed prudent in order to reduce weight. *Leander* turned out over-weight but the four subsequent ships of the class – *Achilles*, *Neptune*, *Orion* and *Ajax* (Figure 28) – benefited from considerable weight savings and welding was used extensively in subsequent cruiser designs [59]. All the ships had a distinguished record during the Second World War. HMS *Ajax* and HMS *Achilles* gained fame following their action (in company with HMS *Exeter*) at the Battle of the River Plate when they engaged the German pocket battleship *Graf Spee*. Only one was lost – HMS *Neptune* was mined 20 miles off Tripoli on 19 December 1941 and she sank about four hours later after hitting two more mines. Rescue attempts were hampered by the minefield and the high risk of air attack and only one survivor was subsequently found four days later [61].

In October 1932, during the detailed design and early construction of the Leander Class cruisers, the high price of the ships prompted the Third Sea Lord and Controller of the Navy to order a review of the design and he proposed number of changes ‘in these times of financial stringency’. These included reducing the gun fire control equipment, elimination of magazine cooling and even a reduction of internal telephones: ‘It is very nice for Lieut. Snooks to be able to sit in his cabin and converse with Lieut. Jones in the neighbouring cabin over the telephone, but it would probably do him more good if he got out of his chair and went and talked to Lieut. Jones’ [15].

The changes to the fire control equipment included the elimination of the after director control tower (DCT). Since it was recognised that if the forward DCT was put out of action, or was temporarily blocked, control would devolve to one of the turret officers, a non-revolving control position fitted out with a minimum of necessary equipment was proposed to be fitted

DSTO-GD-0559

on the after superstructure [15]. These changes, which were approved by the Admiralty Board on 10 November 1932 [62], were the source (in part, at least) of later dissatisfaction in the arrangements in the Leander Class and Modified Leander Class cruisers as expressed by Captain J. W. A. Waller of *Sydney* in October 1938 [63] and the Vice Admiral, Light Forces, Mediterranean in December 1940 [64].

Meanwhile, in July 1932, an investigation had been completed into a revised machinery arrangement for the later ships of the Leander Class. In the ships then ordered, the propelling machinery comprised six boilers and four sets of turbines, two sets of 24,000 SHP driving the outer shafts and two sets of 12,000 SHP driving the inner shafts for a total of 72,000 SHP. The boilers were in three boiler rooms ahead of a forward engine room, a gearing room and an after engine room. In the last three ships, it was proposed to separate the boiler and engine rooms to reduce the vulnerability of the machinery plant to damage. The installation would comprise four boilers in two boiler rooms separated by the forward engine room, with four sets of turbines of equal power – 18,000 SHP on each shaft [15]. The modified arrangement is shown in Figure 29. The new arrangement required the length of the ship to be increased by 8' between perpendiculars and the length of side armour to the upper deck level extended to 141' instead of 84' in *Leander*.

It was also proposed to replace two of the four turbine-driven generators with two diesel-driven generators arranged in wing compartments outboard of B boiler room. These were not emergency generators but enabled the steam plant to be shut down in port. Emergency generators were not fitted in HMA Ships *Hobart* and *Australia* until 1944 [65].

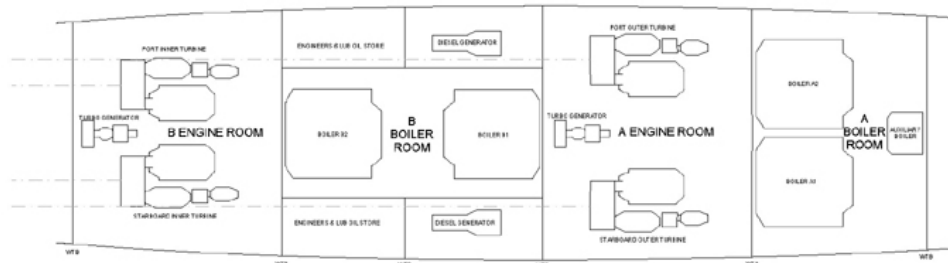

Figure 29 : Arrangement of machinery in the Modified Leander Class cruisers [4]

Despite the proposed changes resulting in even further congestion in an already very crowded ship, they were adopted for the three light cruisers ordered under the 1932 programme, with the ships becoming known as the Modified Leander Class. *Amphion* was ordered from HM Dockyard, Portsmouth, *Apollo* was ordered from HM Dockyard, Devonport, and *Phaeton* was ordered from Swan Hunter & Wigham Richardson Limited at Newcastle-upon-Tyne.

In early 1934, *Phaeton* was acquired by the Australian Government as a replacement for the old cruiser HMAS *Brisbane*. She was renamed HMAS *Sydney* [15]. *Amphion* and *Apollo* were completed for the Royal Navy and were also acquired by Australia in 1938 becoming HMAS *Perth* and HMAS *Hobart*.



Every ship design is a compromise – and warship designers are always faced with the need to make many. They include cost and capability, range, speed and power, crew space and payload space, electrical load and generating capacity, endurance and stores space, protection and weight. The Modified Leander Class cruisers were no exception. At the time the ships were being designed, the need to reduce cost and weight were powerful drivers of design outcomes. Weight is always important in ship design, but the cruisers of the 1930s were also designed within the limitations imposed on the Royal Navy by the Washington and London Naval Treaties. An over-weight ship design could mean that one less cruiser could be constructed within Treaty limits.

Despite the inevitable compromises made during the design process, the Modified Leander Class cruisers were fine, well-built modern cruisers constructed to the highest British Admiralty standards.

### 2.1.2 Description of HMAS Sydney

*Sydney* was laid down on 8 July 1933, launched on 22 September 1934 and completed on 24 September 1935.

*Sydney's* particulars as completed were [66-68]:

|  |  |
|--|--|
| Displacement, light  | 6,701 tons                                     |
| Displacement, half oil   | 8,056 tons                                     |
| Displacement, full load  | 8,940 tons                                     |
| Displacement, standard   | 7,198 tons                                     |
| Length overall   | 562' 3 <sup>7</sup> / <sub>8</sub> "           |
| Length between perpendiculars  | 530' 0 <sup>3</sup> / <sub>8</sub> "           |
| Breadth extreme  | 56' 8 <sup>1</sup> / <sub>2</sub> "            |
| Breadth moulded  | 56' 0"   |
| Depth, from under side of keel<br>to underside of upper Deck amidships | 32' 0" at side                                 |
| Draught, at standard displacement                                      |  |
| Forward  | 15' 3"   |
| Aft  | 17' 3"   |
| Oil fuel capacity  | 1,800 tons                                     |
| Machinery  | Parsons single-reduction geared steam turbines |
| Boilers  | Four   |
| Shafts   | Four   |
| Power  | 72,000 SHP                                     |
| Maximum Speed (designed)   | 32 <sup>1</sup> / <sub>2</sub> knots           |
| Range  | 7,000 n mile at 16 knots                       |

On trials at full power, *Sydney* achieved 33.05 knots with 72,740 SHP at a displacement of 7,105 tons.

DSTO-GD-0559

*Armament:*

Eight 6" Mk XXIII guns on twin mountings Mk XXI, with stowage for 200 rounds per gun.

Four 4" Mk V on single mountings Mk IV, with stowage for 200 rounds per gun.

Three 0.5" quadruple mountings Mk II, with stowage for 2,500 rounds per barrel.

Eight 21" torpedo tubes on two quadruple mountings QR VII, with eight Mk 9 torpedoes.

One depth charge rack for four depth charges with stowage for two additional depth charges.

One aircraft catapult.

Complement

570 (as private ship, peacetime)

2.1.3 Ships Drawings

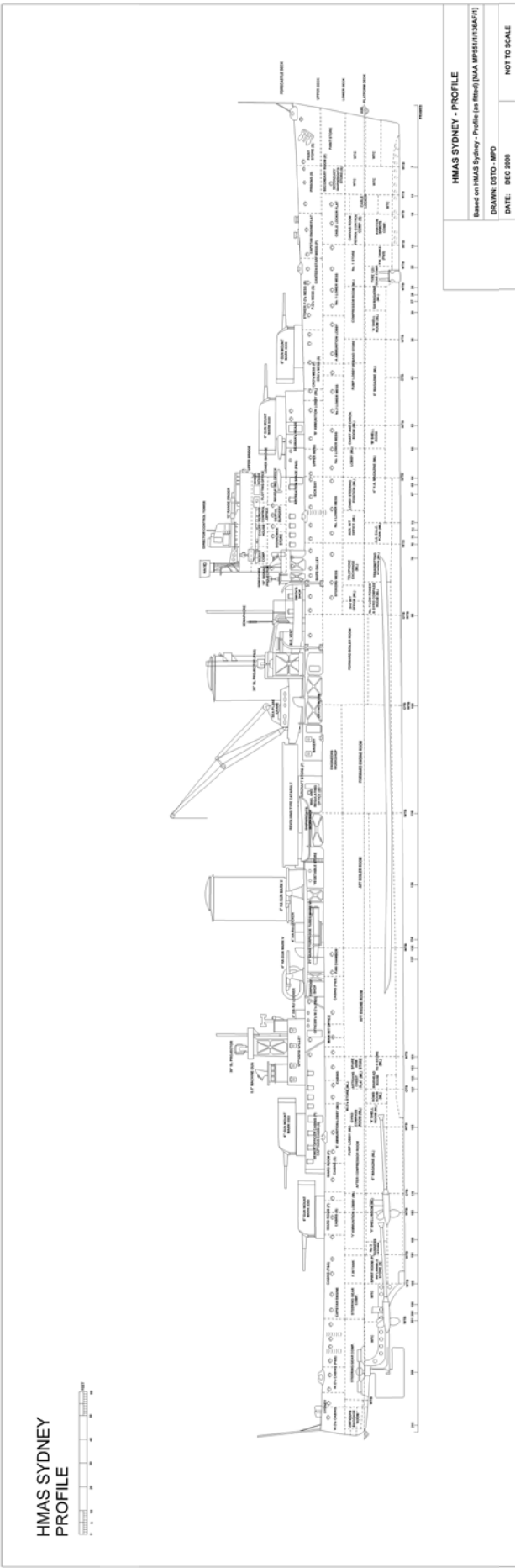

Figure 30: HMAS Sydney – Profile

*This page intentionally blank*



*This page intentionally blank*

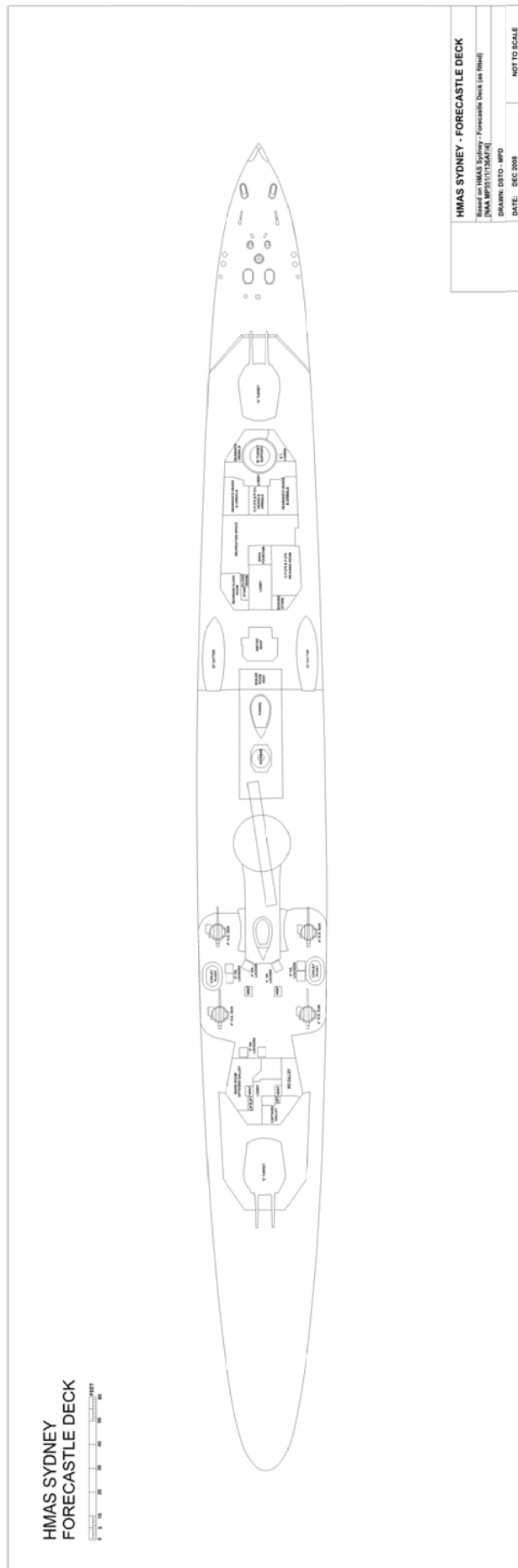

Figure 32: HMAS Sydney – Forecastle Deck

*This page intentionally blank*



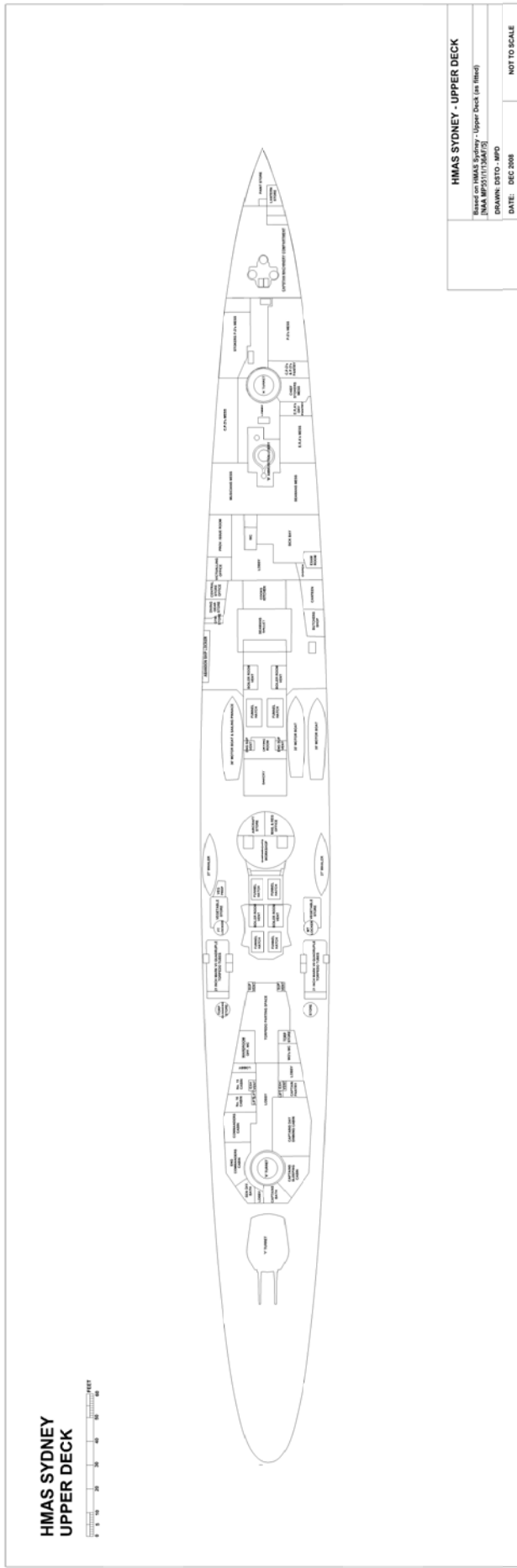

Figure 33: HMAS Sydney – Upper Deck

*This page intentionally blank*

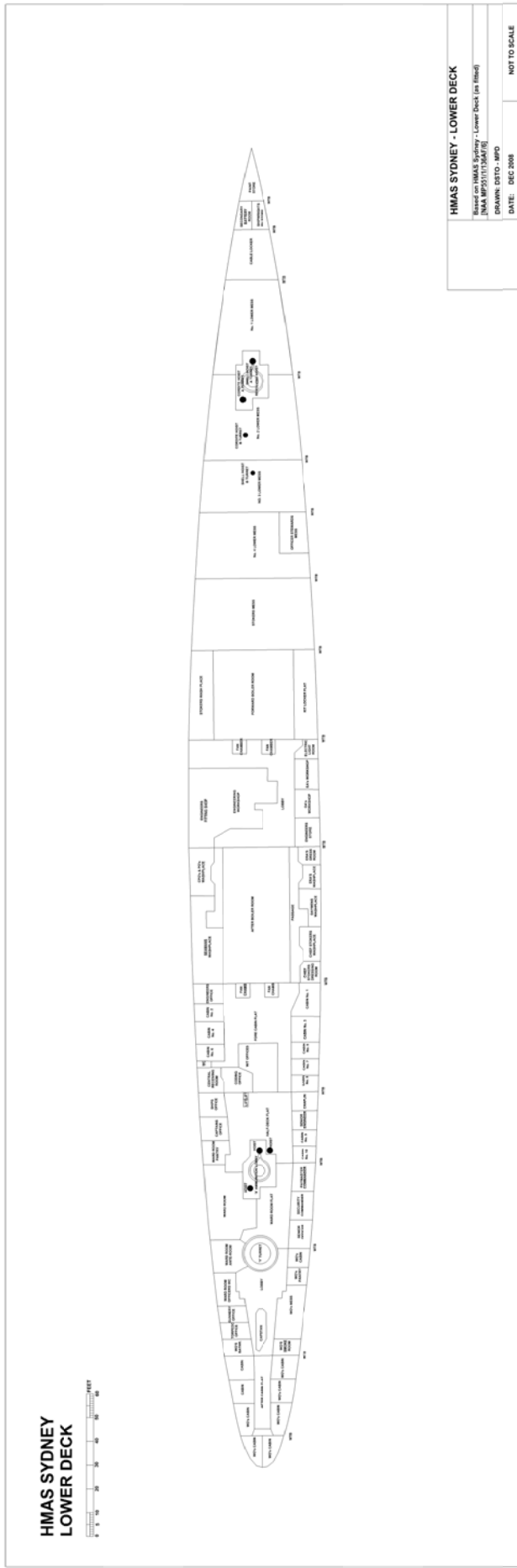

Figure 34: HMAS Sydney – Lower Deck

*This page intentionally blank*

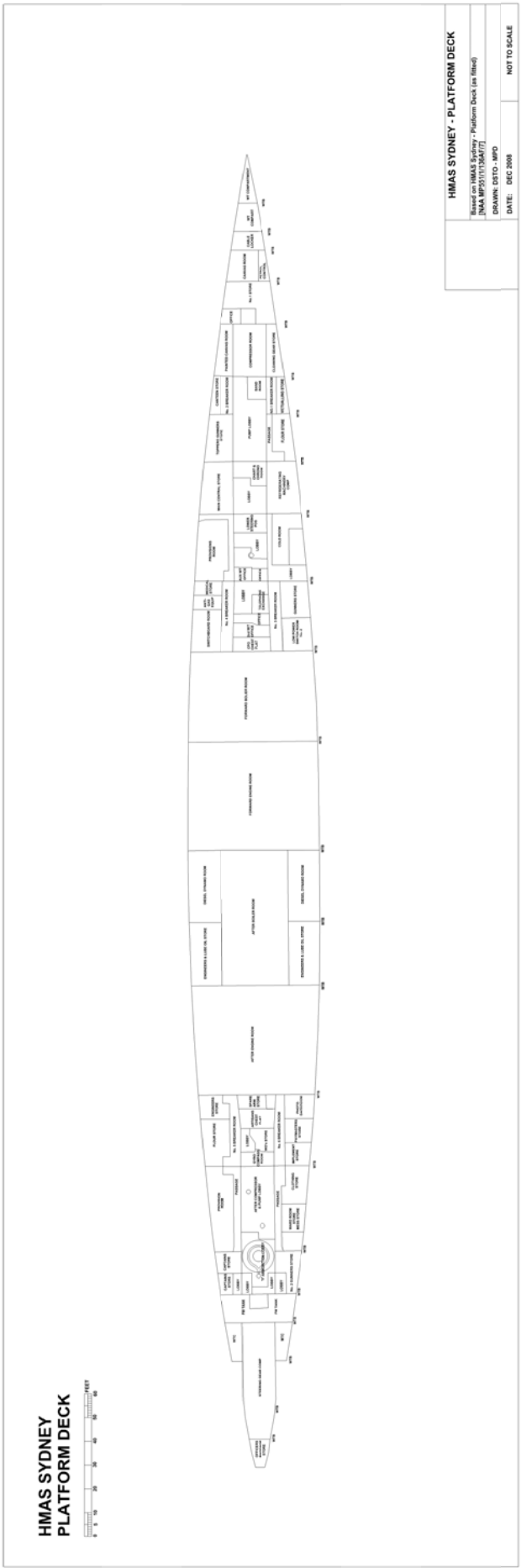

Figure 35: HMAS Sydney – Platform Deck

*This page intentionally blank*



*This page intentionally blank*



## 2.1.4 General Arrangement

*Sydney* was arranged conventionally for a British cruiser of the time, with two superimposed 6" mountings (A & B) forward of the bridge and two (X & Y) aft. The aircraft catapult was fitted amidships and the secondary armament of 4" guns arranged abeam of the after funnel. The ship's boats were arranged amidships and were generally launched by the aircraft crane, except for the two cutters which were intended as sea boats and could be launched by davits. Her two 27 foot whalers could also be launched from davits aft when in port. More details of *Sydney's* boats and lifesaving equipment are given in a later section of this report.

*Sydney* was fitted with two tall masts to support wireless telegraphy aerials and halyards for visual signalling with flags.

*Sydney* had three decks in her hull, upper, Lower and Platform decks. The Forecastle Deck was the uppermost but it did not run the full length of the ship. Below the Forecastle Deck the upper Deck was the uppermost continuous deck. The Lower and Platform decks were not continuous due to the machinery spaces. The space below the Platform Deck comprised the Hold.

Fuel tanks, magazines and some stores were arranged in the Hold, as were the Transmitting Station and High Angle Calculating Position, essential components of the armament. These compartments were arranged just forward of the forward boiler room, as were the No. 1 Low Power Room and a Gyro Compass Room. *Sydney* was one of the first ships in the RAN to be fitted with ASDIC (sonar) and the directing gear was fitted in the hold towards the bow. The petrol for the ship's aircraft was carried in a 1,600 gallon tank in a compartment further forward.

Stores were arranged on the Platform Deck forward. One of the hull and fire pumps was located there, and the Main Switchboard Room, No. 2 Low Power Room and switchboard, W/T offices and the Lower Steering Position were on this deck just forward of the forward boiler room. More stores, another hull and fire pump, a second Gyro Compass Room and the Steering Gear Compartment were on the Platform Deck aft.

Crew accommodation was arranged on the Lower Deck forward. The spaces were fitted out with hammock stowage, kit lockers and mess tables. Kit lockers were also provided in separate spaces. Washplaces for the crew were arranged on this deck. Accommodation in cabins for officers and warrant officers was arranged on the Lower Deck aft. A Wireless Office and Coding Room was also on this deck.

Accommodation for senior sailors was also arranged on the upper Deck forward under the Forecastle Deck. The Sickbay and Crew's Galley were on the upper Deck below the forward superstructure and the enclosed deck space around the Galley and the forward funnel uptakes were also used as a sleeping space for the crew.

A deckhouse on the upper Deck under the catapult housed funnel uptakes, a Shipwrights Workshop, an office and a store. The 4" gun deck was over this part of the upper Deck, and the two sets of torpedo tubes were fitted on the upper Deck approximately abreast the after funnel.

DSTO-GD-0559

The after deckhouse contained a Torpedo Workshop, senior officer accommodation and Officers' Heads. The Captain's, Wardroom and Warrant Officers' galleys were in the after deckhouse at the Forecastle Deck level.

The forward superstructure contained the Crew's Heads, Senior Sailors' Recreation spaces, the Captain's Sea Cabin, the Navigating Officer's Cabin, Armament Office, Plotting Office, Remote Control Office and the Dental Surgery. The Wheelhouse and Bridge were also in this superstructure.

### 2.1.5 Armament

The main armament of *Sydney* was eight 6" BL Mk XXIII guns (which fired a 112-lb shell) in four Mk XXI twin short-trunk mountings. It was first introduced into Royal Navy service in HMS *Leander*, and was fitted to all subsequent RN cruisers, except HM Ships *Tiger*, *Lion* and *Blake* which were completed to a modified design well after the war. The range of the gun was 25,480 yards at an elevation of 45° [69].

The Mk XXI mounting was also introduced in HMS *Leander* and was fitted to all Leander Class, Modified Leander Class and Arethusa-class cruisers. In *Sydney* A and B Turrets were located forward on the Forecastle and Superstructure decks respectively. X and Y Turrets were on the aft superstructure and the lower deck respectively. The mounting had hand ramming but was powered by a self-contained hydraulic system. In this mounting, the guns could elevate to 60° and depress to -5°. The preferred loading angle was +7° to -5°. The revolving weight of the mounting was 95 tons on a mean roller-bearing path diameter of 13' 9" [69]. The arrangement of this mounting in *Sydney* is shown in Figure 37.

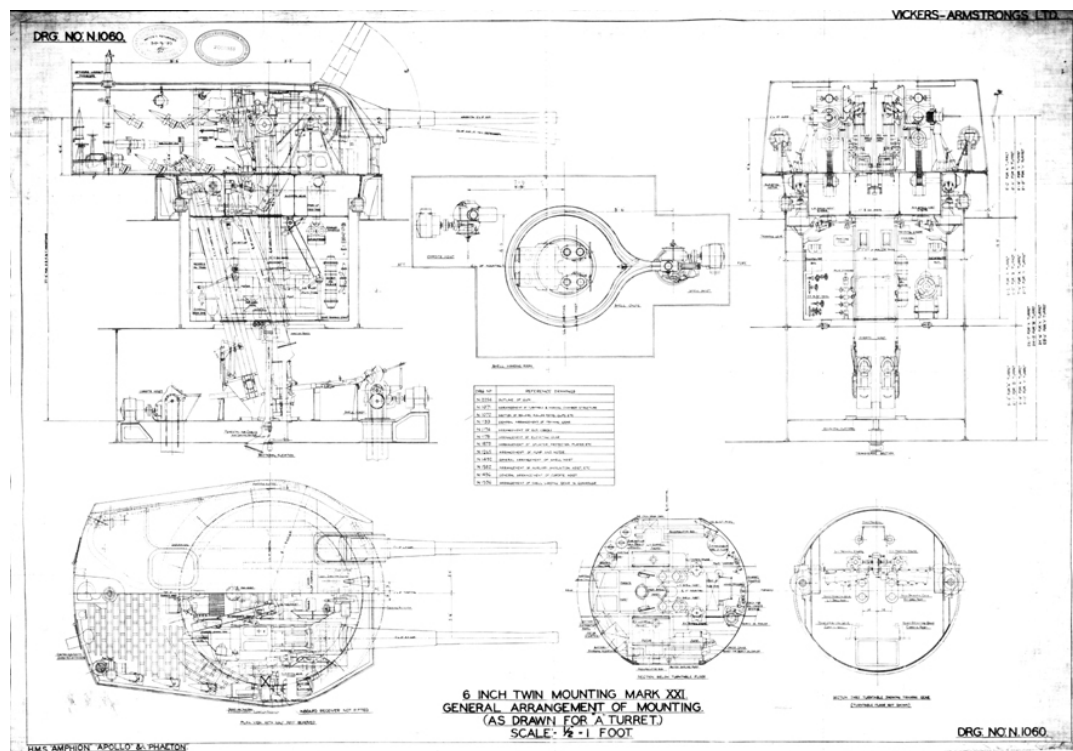

Figure 37 : The arrangement of the 6" Mk XXI mounting in *Sydney* [70]

Each turret had a complement of twenty men [71]. Seven men were required per gun for loading [72]. The nominal maximum rate of fire was between 6-8 rounds per minute [73]. The turrets were supplied with shells from the Ammunition Lobby. There were ten men in the Ammunition Lobby whose role was to transfer the shells and cordite charges from the lift supplying shells and charges from the Shell and Handling Rooms on the decks below to the lifts supplying the turrets. Shells and cordite charges (in flash-resistant cardboard containers) were supplied to each gun ammunition lobby via electrically-driven endless-chain hoists, except for Y Turret for which a two “hand-ups” system was used due to its gun housing being only one deck above its ammunition lobby. Shells and charges could be delivered to the turret at a rate of around 16 per minute [69]. The hoists could also be operated manually in the event of power loss. Each turret had its own Shell Room for storage of the 6” shells and had four men who placed the shells on the hoists bound for the ammunition lobby above. *Sydney* also had two Cordite Magazines which held the cordite charges to propel the shells. There was one magazine for the forward guns and another for the aft guns. The cordite magazines each contained four men who passed the charges in their flash proof cardboard containers to the Handling Room. Three men worked in the Handling Rooms where the charges were placed on a fixed hoist to be sent to the Ammunition Lobby.

A total of 156 men were required to operate the four 6” turrets. A summary of their locations is provided in Table 6.

Fire control for the 6” guns was provided by the Director Control Tower (DCT) on the upper Bridge (the power for which was provided by the Low Power No. 1 system), or individually at the turret with battery power. If complete power was lost those batteries could supply enough power for turret lighting and firing of the guns. In this case the guns would have to be trained by hand and laid with a local sight.

Table 6: Manning of 6” turrets [71]

| Location                  | Number of Men |
|---------------------------|---------------|
| A Turret                  | 20            |
| A Turret Ammunition Lobby | 10            |
| A Turret Shell Room       | 4             |
| A Turret Handling Room    | 3             |
| B Turret                  | 20            |
| B Turret Ammunition Lobby | 10            |
| B Turret Shell Room       | 4             |
| B Turret Handling Room    | 3             |
| Forward Cordite Magazine  | 4             |
| X Turret                  | 20            |
| X Turret Ammunition Lobby | 10            |
| X Turret Shell Room       | 4             |
| X Turret Handling Room    | 3             |
| Y Turret                  | 20            |
| Y Turret Ammunition Lobby | 10            |
| Y Turret Shell Room       | 4             |
| Y Turret Handling Room    | 3             |
| Aft Cordite Magazine      | 4             |
| <b>TOTAL</b>              | <b>156</b>    |

DSTO-GD-0559

### 2.1.6 Director Control System

The Director Control system consisted of a Captain's Sight on the bridge for target designation, the Director Control Tower (DCT), a backup Aft Control Position and the Transmitting Station (TS). Once a target had been sighted, the Captain's Sight sent the target's bearing to the DCT and/or Aft Control. The DCT then measured the bearing and range to the target. This information was passed to the TS, where a Fire Control Table (in this case the Admiralty Fire Control Table Mk V) was used to calculate the bearing and elevation of the guns. This information was then passed to the Turrets. The DCT was manned by fourteen men.

Modes of fire control in *Sydney* were [72]:

- Primary Gun Control via the DCT and/or the Aft Control Position via TS.
- Secondary Control where control was from any advantageous position via TS.
- Emergency Control from any convenient position direct to the turrets.
- Group Control by the Officer of the Quarters of any two guns.
- Local Control by the Officer of the Quarters of a single turret.
- Gunlayer Control from within the turret.

### 2.1.7 Aft Control Position

*Sydney* was also fitted with a simple Aft Control Position. This non-rotating structure sat upon the aft superstructure. It had communication with the TS, DCT and the bridge. It had a Mark II training sight, gun range receiver, gun deflection receiver and an Evershed target bearing indicator. There was no provision for range finding – range was provided by the rangefinders on the bridge [74]. The Aft Control Position was manned by two men, but would also have been the Executive Officer's station if the bridge was out of action.

### 2.1.8 4" HA Guns

*Sydney* carried four single 4" QF Mark V anti-aircraft guns mounted on Mark IV single mounts. This mount allowed for both high- and low-angle firing on elevations between -5° and +80° [69]. These guns were manually operated and were situated aft on the 4" Gun Deck, which was above the torpedo tubes and the vegetable stores. There were two guns (P1 and P2) on the port side and two (S1 and S2) on the starboard side.

The rate of fire of the 4" guns was 10-15 rounds per minute. This rate of fire was dependant on the elevation of the gun and was approximately 14 rounds per min at 50° elevation [73].

Fire control was provided by the High Angle Control Station (HACS) as described below. The guns could also be used in local control using a simple optical sight.

Some 4" ammunition was stored locally on the Gun Deck in 'ready-use' (RU) lockers, while the bulk of the ammunition was stored within the 4" Magazine located forward in the Hold.

The maximum range of these guns is quoted as 16,430 yards (15,020 m) at 44° elevation with a ceiling of 31,000 ft (9,450 m) at 80° with a 31 lb (14.06 kg) projectile [69]. Each gun

had a crew of approximately six men with an officer in charge. Normally, at cruising stations, two of the 4" AA guns would be manned, while at action stations all 4" guns would be manned [75].

### 2.1.9 High Angle Fire Control

For high angle control *Sydney* was fitted with the Mark III HACS located on a tower at the aft end of the forward Superstructure [74]. The HACS operated in the same fashion as the DCT for the 6" guns, in that it kept the 4" guns on target by transmitting range and height data to the High Angle Calculating Position (HACP) located in the Hold which calculated the elevation and bearing required by the guns. This information was then transmitted to the receivers on the 4" gun mounts.

The HACS crew consisted of 5 men including a Layer and Trainer using telescopes and a Control Officer tracking the target. Training and elevation of the HACS director was by hand.

The HACP calculated the position of the target from the information supplied from the HACS on the HACS Mark III Table. The table was able to calculate the future position and the ballistic height. This information was translated into a fuze setting for the 4" shells. The HACP required 11 men for operation [72].

### 2.1.10 Torpedoes

*Sydney's* torpedo armament consisted of eight 21" Mark IX torpedoes of the burner cycle type. These torpedoes had an explosive charge of 750 lb of TNT and a range of 10,500 yards (9,600 m) at 35 knots or 13,500 yards (12,350 m) at 30 knots.

The torpedoes were fired from two quadruple QR Mark VII above-water torpedo tubes [74] mounted port and starboard on the upper Deck under the 4" Gun Deck (see Figure 38). The quadruple tubes were stowed in the fore-and-aft position. The tubes were not symmetrical about their centre line. The inboard side in the stowed position had two platforms and equipment for manually rotating the tubes by means of a handle. No additional torpedoes were carried aboard *Sydney* and it was therefore not possible to reload the torpedo tubes [74, 76].

DSTO-GD-0559

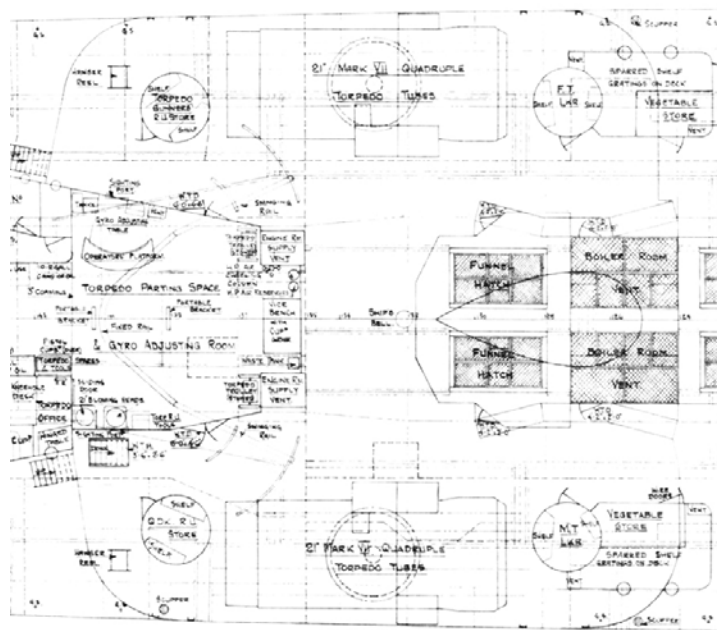

Figure 38: General Arrangement showing torpedo tubes [58]

The maintenance and testing of the torpedoes was carried out in the Torpedo Parting Space & Gyro Adjusting Room located in the aft superstructure between the two sets of tubes.

The Torpedo Department's men were also responsible for the electrical systems of *Sydney*. Each torpedo battery was manned by a separate team when the ship came to action stations and by one team at cruising stations. These men were usually located in and around the Torpedo Parting Space conducting maintenance and testing of the torpedoes and their tubes. Those men not part of a torpedo tube crew would be attending to electrical equipment. At action stations the torpedo tubes were turned outboard [77, 78].

Each torpedo team consisted of five men. Each team had a Leading Torpedo Operator who controlled the firing of the tubes from a canopy which was located in the middle of the tubes. This Leading Torpedo Operator would be in telephone contact with the bridge awaiting the Captain's/Torpedo Officer's orders [77, 78].

One more Leading Torpedo Operator would be located on the deck behind the tube to control the releasing of the safety pins which were fitted to each tube. Additionally, there were two Ratings, one each side of the torpedo tubes, setting the running depth of the torpedoes [77, 78].

The firing of the torpedoes was in sequence with the most aft tube in a quadruple mount being fired first and the other three being fired in order going forward. This sequence was used to avoid the possibility of collisions between fired torpedoes and turbulence from associated tracks [79].

On *Sydney* the port tubes were labelled F-I-R-E respectively, indicating the firing sequence. Thus 'F' was the most-aft tube on the port side and fired first, while 'E' was



DSTO-GD-0559

depth setting keys. When the charges were not required they were placed into 'safe' mode by means of the depth setting key [74].

### 2.1.12 Smoke Laying

Although only used for defensive purposes, *Sydney* was able to create a smoke screen by delivering a jet of atomised oil into a boiler furnace. This resulted in incomplete combustion of excess oil, producing a heavy black smoke [74]. She was also fitted with up to three Mk 4 smoke floats located on the upper deck at the stern.

### 2.1.13 Construction and Subdivision

*Sydney* was constructed of steel and transversely framed. The stiffness of a ship's hull is provided by the shell plating and a framing system which comprises girders which run fore and aft (longitudinals) or across the ship (frames). In a transversely framed ship the frames are quite closely spaced with relatively few longitudinal girders to provide longitudinal strength. Amidships, where the bending moments are greatest, the longitudinal girders are usually made continuous with the frames worked intercostally. Near the ends, where local strength considerations predominate, the frames are usually continuous and the longitudinals are fitted intercostally. In a longitudinally framed ship the frames are widely spaced and the longitudinals are more numerous and closely spaced.

The size of the frames and longitudinals depends on their spacing and the thickness of the shell plating. Where possible, longitudinals are placed where they can provide support to important items of machinery like boilers, main engines and gear boxes.

In warships it is usual to start the numbering of frames forward and work aft – the reverse of merchant ship practice. Frame 0 is at the intersection of the design waterline with the stem (known as the forward perpendicular). The after perpendicular is at the centreline of the rudder stock and in *Sydney* that was at frame 208. Her designed length between perpendiculars was 530' 0". As actually built this figure was 530' 0<sup>3</sup>/<sub>8</sub>" – good work by Swan Hunter's shipwrights. The frame spacing in *Sydney* varied between three feet at the ends to 6 feet amidships, with some local variations [80]. Figure 40 shows the shape of the frames in *Sydney* as well as the trace of longitudinals and shell plate edges.



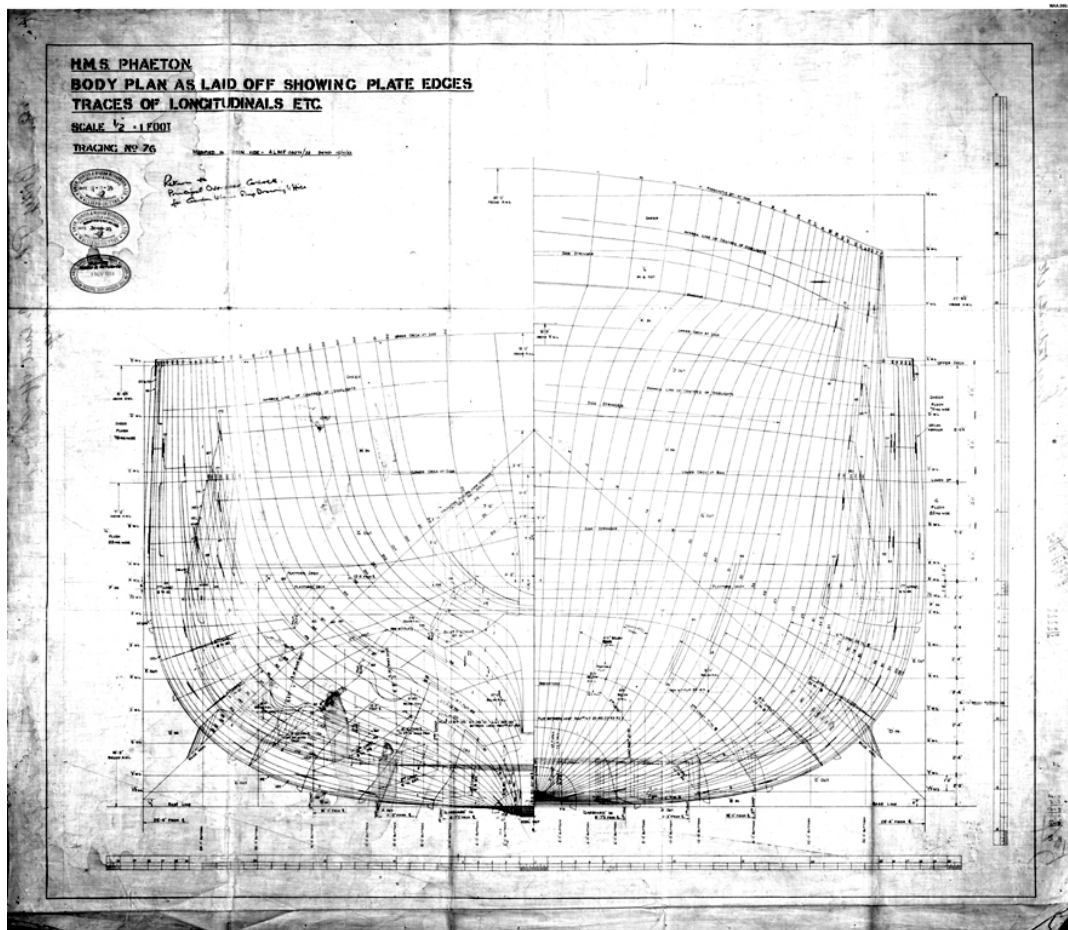

Figure 40: Sydney Body Plan. Fore-body frames are on the right and after-body frames are on the left. Generally only every second frame is shown [81].

*Sydney* was predominantly of riveted construction. However, in keeping with her designer's advocacy of welding in ship construction, a considerable amount of the structure was welded, including decks and bulkheads, particularly towards the ends of the ship where stresses were lower.

The hull of *Sydney* was subdivided into a large number of watertight compartments. The purpose of this subdivision was to create separate compartments like oil tanks and to provide a considerable resistance to flooding in the event of damage. There were 23 transverse watertight bulkheads below the Platform Deck, 16 of which extended to at least the upper Deck. Longitudinal bulkheads have to be placed with care in warships due to the possibility of asymmetrical flooding causing unacceptable angles of heel in the event of side damage. Nevertheless some are needed and in *Sydney* longitudinal bulkheads extended from the watertight transverse bulkhead (WTB) at frame 25 to the WTB at frame 86 and between the WTBs at frames 131 and 191 (Figure 41). These bulkheads, which were below the Platform Deck, formed the boundary of important compartments like magazines and the Transmitting Station.

Penetrations in WTB are kept to a minimum. Below the waterline in *Sydney* there were only two doors penetrating WTBs — at frame 76 in the Hold, between the Transmitting Station and the HA Calculating Room, and about frame 183 on the Platform Deck where a convoluted passage was possible through the Y Ammunition Lobby. To access all

DSTO-GD-0559

other compartments in the Hold and on the Platform Deck, the crew needed to travel along the Lower Deck before descending, and forward of frame 64 access between WTBs was only possible from the upper Deck. There was a convoluted passageway possible through the A Ammunition Lobby about frame 35.

Penetrations for gear rods, cables and voice pipes through WTB were through glands sealed with a sealing composition. Penetrations for water pipes were welded and fitted with isolating valves.

A number of watertight compartments within the ship could be used as ballast tanks to compensate for low fuel conditions and water ballast could be used to adjust trim or heel.

The introduction of the divided machinery spaces described above (see Figure 29), a practice adopted for all subsequent British cruiser designs, has proved to be somewhat controversial due to the introduction of longitudinal bulkheads (in *Sydney* between transverse WTB 116 and WTB 135) well off the centreline extending from the bottom to the upper Deck. The risk of excessive heel resulting from asymmetric flooding due to the presence of these bulkheads must have surely have been recognised when *Sydney* was built. One of the damage cases included in the examples of damage control for *Sydney* dated September 1940 assumed penetration of the hull at WTB 135 with a consequent heel of 18° and near immersion of the upper Deck edge [82]. The example recommends counter flooding to reduce the angle of heel. The extent of damage assumed in these examples seems, however, very optimistically small in light of the WWII experience.

The late David K. Brown RCNC, a past Deputy Chief Naval Architect in the UK MOD(N) was critical of this aspect of cruiser design pointing out that, in the event of flooding of one wing space as well as both engine rooms and the after boiler room, stability would be greatly reduced and rapid capsizing was likely. This type of flooding contributed to the capsizing of five ships. HMS *Cleopatra* was torpedoed in this area and went to a large angle of heel (about 15°) but was saved by rapid counter flooding [83]. When this layout of machinery spaces was adopted the Constructors at the Admiralty did not have the benefit of WWII experience and perhaps did not regard the extent of damage which would cause such flooding as likely.

In addition to the subdivision provided by the longitudinal and transverse watertight bulkheads, *Sydney* was provided with a double bottom between WTB 76 and WTB 151 which extended from the keel to the upper Deck between WTB 86 and WTB 151. This double bottom comprised a number of tanks and watertight compartments and provided a measure of protection to the machinery spaces in the event of minor outer-bottom damage, for example as a result of grounding (Figure 41).

Whilst most watertight and oil tight compartments were tight whilst undamaged and with access openings closed, compartments which were designed to carry oil, fresh water or water ballast or which might be intentionally flooded (i.e. magazines) were provided with air escapes. Air escapes from oil tanks terminated in the open air and were fitted with anti-flash gauzes to limit the risk of fire. Air escapes from other compartments in some cases terminated inboard [84].

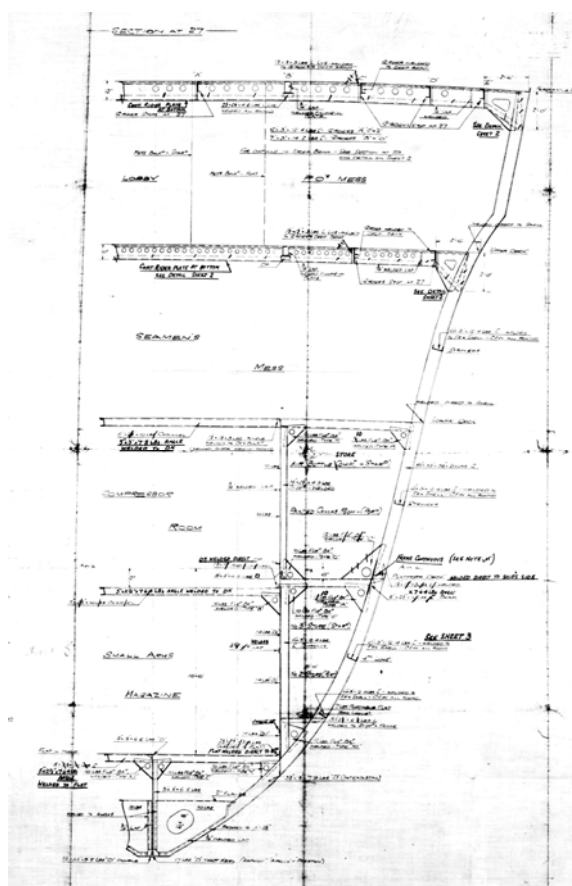

Figure 41: A typical frame, in this case Frame 27, showing the longitudinal bulkhead outboard of the Small Arms Magazine and the Compressor Room [80]

Compartments within the boundaries of decks and watertight bulkheads were formed by the erection of minor bulkheads. Minor bulkheads enclosing wet spaces like washplaces and heads and spaces like switchboard rooms were constructed of swedged 5 lb steel plate welded to the deck and deckhead. Bulkheads to storerooms and similar spaces were constructed of 3/16" thick steel-faced plywood. The plywood bulkheads were generally stopped 1 foot below the deckhead and the gap filled with wire mesh. Longitudinal cabin bulkheads were constructed of 5 lbs steel – transverse bulkheads of plywood – all stopped 1 foot below the deckhead with wire mesh above [85].

#### 2.1.14 Armour and Protective Plating

The original Staff Requirement for the Leander Class cruisers specified that the ships should be protected so that:

The ship's side was immune to 6" shell fire above 10,000 yards,  
 Crowns to be immune to 6" shell fire below 16,000 yards,  
 The sides were to be immune to 4.7" shell fire above 4,700 yards, and crowns were to be immune to 4.7" shell fire at all ranges [67].

DSTO-GD-0559

The ship's side armour was intended to protect the machinery spaces. It did not, for example, extend sufficiently far forward to protect the Main Switchboard Room. The extent of the side armour in *Sydney* is shown in Figure 42.



Figure 42: Profile of *Sydney* showing the extent of ship's side armour [5]

The armour, as fitted to *Sydney*, is shown below [5]. NC is non-cemented armour and D1 is high-tensile steel.

|  |  |
|--|--|
| Machinery Spaces   | Sides 4", comprising 3" NC and 1" D1<br>Crown 1 <sup>1</sup> / <sub>4</sub> " D1<br>Ends 1 <sup>1</sup> / <sub>2</sub> " D1  |
| Magazines, B Shell Room  | Sides 3 <sup>7</sup> / <sub>8</sub> ", comprising 3 <sup>1</sup> / <sub>2</sub> " NC<br>and 3 <sup>3</sup> / <sub>8</sub> " D1<br>Crown 2 <sup>3</sup> / <sub>8</sub> ", comprising 2" NC<br>and 3 <sup>3</sup> / <sub>8</sub> " D1<br>Ends 2 <sup>7</sup> / <sub>8</sub> ", comprising 2 <sup>1</sup> / <sub>2</sub> " NC<br>and 3 <sup>3</sup> / <sub>8</sub> " D1 |
| Transmitting Station, Forward<br>Low Power Switch Room &<br>Gyro Compass Compartment | Sides 1" D1<br>Crown 1 <sup>1</sup> / <sub>2</sub> " D1<br>Ends 1 <sup>1</sup> / <sub>2</sub> - 2 <sup>7</sup> / <sub>8</sub> " D1   |
| A, X and Y Shell Rooms<br>and Thrust Block Recesses                                  | Sides 1" D1<br>Crown 1" D1<br>Ends 1" D1   |

|   |        |                                    |
|---|--------|------------------------------------|
| Steering Gear Compartment                                 | Sides  | 1 <sup>1</sup> / <sub>2</sub> " D1 |
|   | Crown  | 1 <sup>1</sup> / <sub>4</sub> " D1 |
|   | Ends   | 1 <sup>1</sup> / <sub>2</sub> " D1 |
| Turrets   | Faces  | 1" D1                              |
|   | Sides  | 1" D1                              |
|   | Rears  | 1" D1                              |
|   | Crowns | 1" D1                              |
| Turret Trunks and Ammunition Lobbies                      |        | 1" D1                              |
| DCT   | Sides  | 1" D1                              |
|   | Crown  | 1" D1                              |
| Compass Platform, Remote Control Office and Plotting Room | Sides  | 3/8" D1 (Bulletproof)              |
|   | Crown  | 1/2" D1 (Bulletproof)              |
| Upper Bridge  | Sides  | 3/8" D1 (Bulletproof)              |
| After Control   | Sides  | 3/8" D1 (Bulletproof)              |
|   | Crown  | 1/2" D1 (Bulletproof)              |

### 2.1.15 Machinery

*Sydney* was fitted with four Admiralty 3-drum watertube boilers in two boiler rooms (Figure 43). The forward Boiler Room was also fitted with an auxiliary boiler to supply saturated steam for domestic purposes and to supply the steam-driven forced-draft fans and other auxiliaries when flashing up the main boilers. The main boilers were arranged abreast (A1 starboard and A2 port) with superheated steam supplied to forward Engine Room through a main stop valve on the centreline at WTB 116. Under normal conditions, A1 and A2 supplied the steam for the propulsion turbines in forward Engine Room only, but an emergency stop valve was fitted which enabled steam to be directed to aft Engine Room, or vice versa [86]. The forward Boiler Room was pressurised and was entered by airlocks, port and starboard, at the forward end.

Auxiliary steam was supplied to forward Engine Room through two connections port and starboard. Auxiliary steam could also be supplied to aft Engine Room, and vice versa. The auxiliary steam drove turbo alternators, fuel and feed pumps, air ejectors, circulating water pumps and evaporators [86].

The forward Engine Room was fitted with two sets of Parsons single-reduction geared turbines, one driving the port-outer propeller shaft and the other the starboard. Each 18,000 SHP turbine set comprised a cruising turbine, a high-pressure turbine and a low-pressure turbine mounted on top of the condenser and connected to a reduction gear box. Apart from auxiliaries the engine room also contained a 300 kW turbo generator.

DSTO-GD-0559

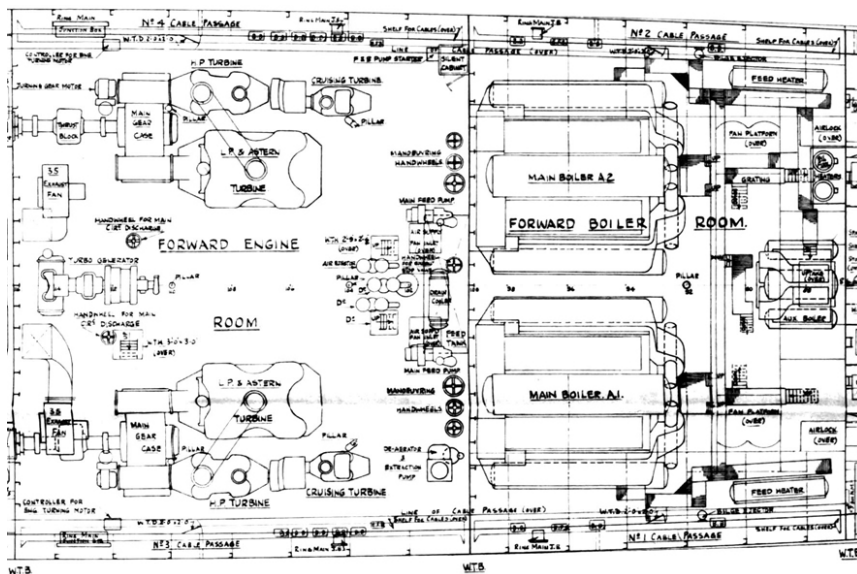

Figure 43: Arrangement of forward Boiler Room and forward Engine Room [4]

The aft Boiler Room was fitted with two boilers, arranged fore and aft (B1 forward and B2 aft) as shown in Figure 44. Like the forward space, the aft Boiler Room was pressurised by the forced draft fans and was entered through two air locks, port and starboard.

The aft Engine Room was similar to the forward Engine Room with two sets of propulsion turbines driving the port and starboard inner propeller shafts. Another 300 kW generator was fitted in this space along with the usual auxiliaries and four evaporators for the production of boiler feed water and fresh water for domestic use. Both engine rooms were ventilated by electrically-driven fans and in each the manoeuvring valves were located at the forward end of the space.

All turbines drove three-bladed fixed-pitch propellers.

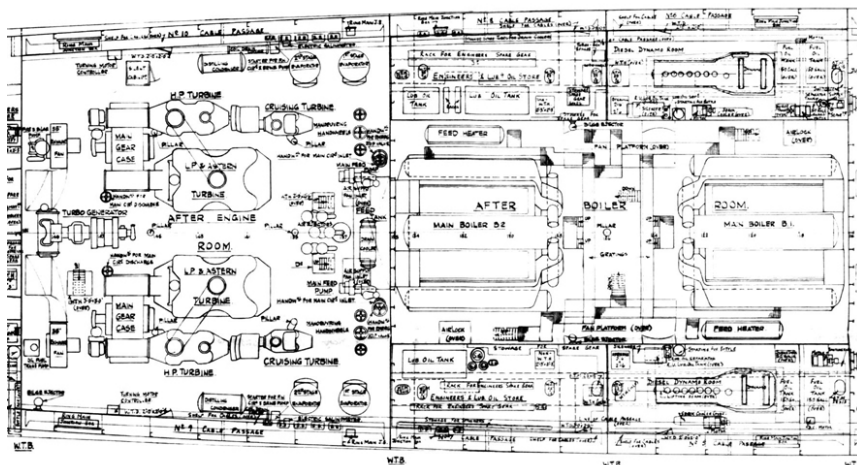

Figure 44: Arrangement of the aft Boiler Room and the aft Engine Room [4]

*Sydney* carried 1473.58 tons of furnace fuel oil (at 95% capacity) which was carried in 21 tanks arranged as follows [87]:

|                                    |             |
|------------------------------------|-------------|
| Frames 43 to 86 (Tanks A1 to A8)   | 900.67 tons |
| Frames 86 to 100 (Tank B1)         | 28.36 tons  |
| Frames 100 to 116 (Tanks X1 to X4) | 174.01 tons |
| Frames 135 to 151 (Tanks X5 to X8) | 138.21 tons |
| Frames 151 to 179 (Tanks Y1 to Y4) | 232.33 tons |

A total of 229.22 tons of diesel oil (at 95 % capacity) was carried between frames 116 and 135 in tanks B2 to B7.

Except for tank B1 (which was on the centreline), even numbered tanks were on the port side and odd numbered tanks were on the starboard side. Furnace fuel oil tanks (FFO can be very viscous when cold) were fitted with steam heating coils.

## 2.1.16 Steering Gear and Telemotor System

### 2.1.16.1 Description of Steering Gear

*Sydney* was fitted with a single partly-balanced rudder fitted on the centreline at frame 208 (see Figure 45). A balanced rudder has part of its area before the axis of the rudder stock so that the pressure of the water on the forward portion partly balances that on the after portion reducing the torque required to turn the rudder. The rudder is only partly balanced so that, should the steering gear fail, the pressure on the part of the rudder aft of the axis of the rudder stock will overcome the pressure on the part forward of the axis so that the rudder will tend to trail amidships (i.e. fore and aft). The partial balance also makes the rudder easier to turn by hand and reduces the size and power of the steering gear necessary to steer the ship.

DSTO-GD-0559

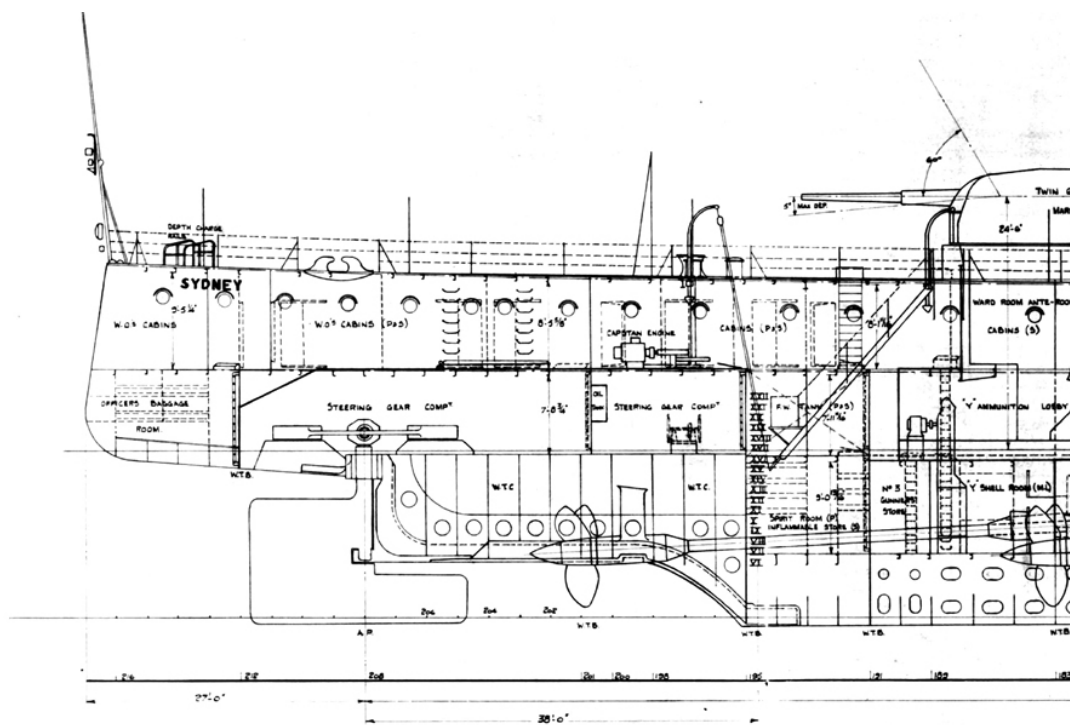

Figure 45: Sydney Rudder's [1]

*Sydney* was fitted with electro-hydraulic steering gear located on the Platform Deck between frames 195 and 212. The compartment was protected by 60 lbs Grade D1 steel on the sides and 50 lbs Grade D1 steel on the top [5]. The steering gear comprised two double-ended hydraulic rams, one each side of the rudder crosshead. The steering gear compartment contained two electrically-driven Williams-Janney variable-delivery hydraulic pumps which provided the power for the rams. In a 'silent compartment' in the forward part of the steering gear compartment there was an After Steering Position, with a wheel which could operate the steering gear locally. The steering gear compartment also contained a hand-driven hydraulic pump, with two wheels so that two helmsmen could operate it, which enabled the ship to be steered by hand if the power supply to the hydraulic pumps failed, although this method of operation would be slow.

In addition to the After Steering Position *Sydney* could be steered from the Wheelhouse or the Lower Steering Position.

The Wheelhouse was located on the Lower Bridge Deck between frames 64 and 66 immediately below the compass platform on the upper Bridge Deck. It contained a steering pedestal and engine room telegraphs for transmitting engine orders for the control of the main engines. Gyro compass repeaters were fitted for the use of the helmsman. The wheelhouse was unarmoured. The arrangement of the wheelhouse is shown in Figure 46.





DSTO-GD-0559

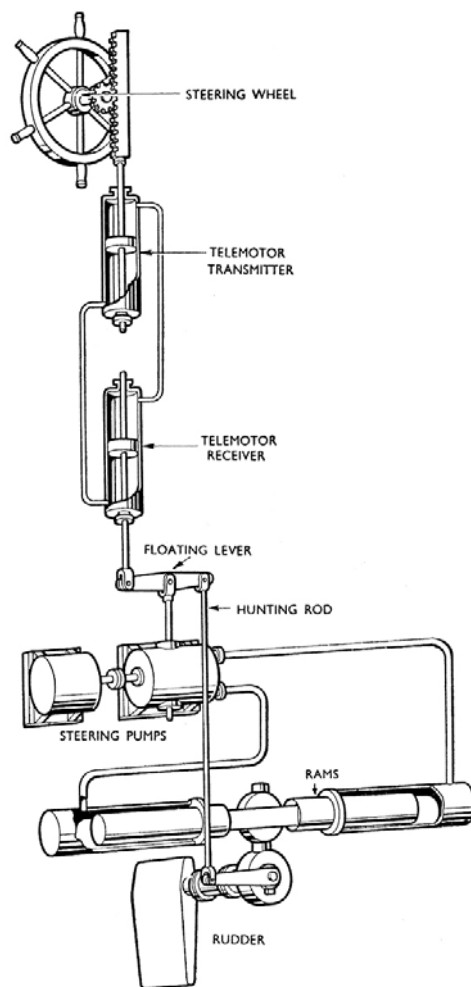

Figure 48: Simplified arrangement of electro-hydraulic steering gear [88]

The steering gear is operated by a steering pedestal where a wheel activates a ram in a cylinder (the telemotor transmitter) to force a fluid (50% water, 50% glycerine) through pipes to a telemotor receiver located in the steering gear compartment. Movement of the ram in the transmitter is duplicated by movement of the ram in the receiver. The movement of the receiver ram activates a lever which controls the flow of pressurised oil from the steering motor pumps to the hydraulic rams, causing the rudder to turn proportionally to the movement of the wheel.

The telemotor receiver is fitted with a powerful spring which returns the ram to the central (amidships) position if the helmsman releases his hold on the wheel. *Sydney* was fitted with a twin-cylinder telemotor receiver, similar to that shown in Figure 49.

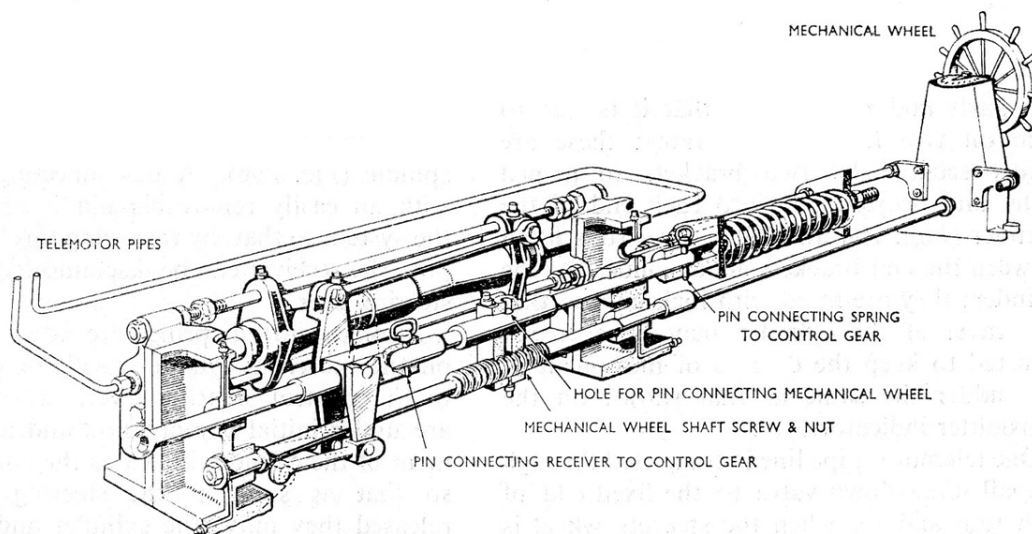

Figure 49: A twin-cylinder telemotor receiver (one half of the unit is shown) [88]

The steering pedestals in the Wheelhouse and the Lower Steering Position were connected to a change-over valve panel on the starboard bulkhead of the Lower Steering Position. From this panel, pipes were led to the steering gear compartment – one pair on the port side of the ship and one on the starboard side. They terminated in another change-over panel to which the port and starboard telemotor receivers were connected [86].

The change-over valve panels enabled, for example, the Wheelhouse transmitter to be connected to the starboard receiver via the port-side telemotor pipes, and the Lower Steering Position transmitter to the port receiver via the starboard pipes – or any one of several other possible combinations. In normal operation, one steering motor pump would be in operation with all hydraulic cylinders connected.

The actual run of the telemotor pipes in *Sydney* is not known, although the information is available for her sister-ship, *HMAS Hobart*. The ships were built by different shipbuilders, so whilst the arrangement in each was likely to be similar, it might not have been identical. In *HMAS Hobart* (see Figure 50) the port pair of pipes was led out to the port side, probably supported by pipe hangers directly under the Lower Deck (the deck above the Lower Steering Position). There the pipes ran aft close to the ship's side until about frame 86, the forward bulkhead of the forward Boiler Room, where they were led inboard of the cable passage at the ship's side. The starboard pair of pipes was similarly run, although for a shorter length directly at the ship's side [89].

If the pipes in *Sydney* were run in the same manner, the telemotor pipes would have been extremely vulnerable to shell fire between the Lower Steering Position and the forward Boiler Room bulkhead, being unprotected by armour and close to the ship's side. From the forward bulkhead of the forward Boiler Room to the after bulkhead of the aft Engine Room the pipes were protected by the side armour, and further aft the location of the pipes a short distance inboard from the side of the ship would have given some protection.

DSTO-GD-0559

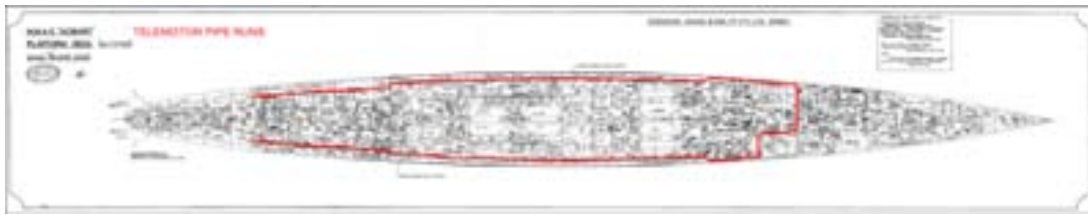

Figure 50: HMAS Hobart's run of telemotor pipes

### 2.1.17 Water Services

*Sydney* was fitted with a fresh water service (hot and cold) for domestic purposes and a pumping, flooding and draining system in order to [90, 91]:

- Clear the ship of drainage and bilge water,
- Provide sea water for fire fighting and spraying systems, deck and cable washing and the sanitary service,
- Enable deliberate flooding of compartments below the waterline to correct heel or trim in the even of damage, or to prevent fire or explosion, and
- Pump out flood water in the event of damage.

A brief description of each of these systems is given below.

#### 2.1.17.1 Fresh Water – Cold

The Fresh Water (FW) Service drew water from fresh water tanks aft in the Pand forward in the Hold. The tanks provided sufficient water for a few days' consumption, and were topped up with fresh water from the ship's distillers. Two 5-ton electric pumps supplied gravity tanks, controlled automatically by the float switches in the gravity tanks. The FW Service ran under the deckhead, on the port side of the Platform and Upper decks, as shown by the green lines in Figure 51 [91-96]. The FW Service could be cross linked to the Main Service (salt water) or to the Main Suction for fire-fighting purposes.



Figure 51: Fresh Water Service is indicated in green (the hot water is not shown); the Fresh Water Tanks are also marked in green. The thick red line indicates the saltwater or Main Service, and the thinner red line is the small bore feed to sanitary spaces. The Main Suction is indicated with blue lines.

#### 2.1.17.2 Fresh Water – Hot

The hot fresh water system took feed from the cold fresh water system, with hot water service tanks in all sanitary and galley spaces, which were located on the Forecastle, upper and Lower Decks. This service and associated header tanks are not indicated on Figure 51.

#### 2.1.17.3 Pumping, Flooding and Draining

The Main Suction in *Sydney* was a continuous 5" diameter pipe (reduced at the ends) which was run on the port side of the ship about 4' above the design waterline. It was connected to two 50-ton centrifugal pumps forward and aft on the Platform Deck and to the fire & bilge pumps in each boiler and engine room. Sluice valves were fitted at watertight bulkheads. All principal compartments were fitted with suction connections via branch lines from the main. Valves controlling the main and the branch lines could generally be operated by extended spindles with handwheels on the Lower Deck – those forward of WTB 35 were led to the upper Deck.

The Main Service (salt water) was another 5" pipe run fore and aft under the upper Deck fitted with sluice valves at each main bulkhead. The valves were operated from the Lower Deck. Branches were taken from the Main Service for the firemain and washdeck services, flushing heads and soil pipes, supplying bathrooms and washplaces and other uses like filling practice torpedo heads. Seawater from the Main Service was also used for cooling water for diesel-driven generators, refrigerating and air compressing plant, steering gear, capstan bearings, seawater coolers in gun mountings and, most importantly, spraying systems in magazines, shell rooms and ammunition lobbies.

DSTO-GD-0559

Cross connections and isolating valves were fitted to risers from fire and bilge pumps to the Main Service to enable damage to the system to be isolated or by-passed if necessary. Hose connections in both the Main Service and main suction enabled compartments to be flooded or drained as necessary through hatches or manholes. There were hoses and nozzles located nearby each hose connection point.

Magazines and shell rooms, bomb rooms, the aviation spirit compartment and spaces with flammable materials or liquids like the spirit room and the inflammable store could be flooded directly from the sea. Other spaces, like double bottom compartments in engine and boiler rooms and oil fuel tanks outside the machinery spaces could be flooded by hoses connected to branches on the main service.

Compartments above the waterline were fitted with drains which discharged over the ship's side. upper deck scuppers were also fitted to help clear the upper decks of water. All these drains terminated above the waterline and, along with soil and waste pipes from galleys, heads and washplaces, were fitted with storm valves (screw-down non-return valves) to prevent back-flow of sea water. Even the ship's side armour was penetrated by these discharges, as shown in Figure 52.

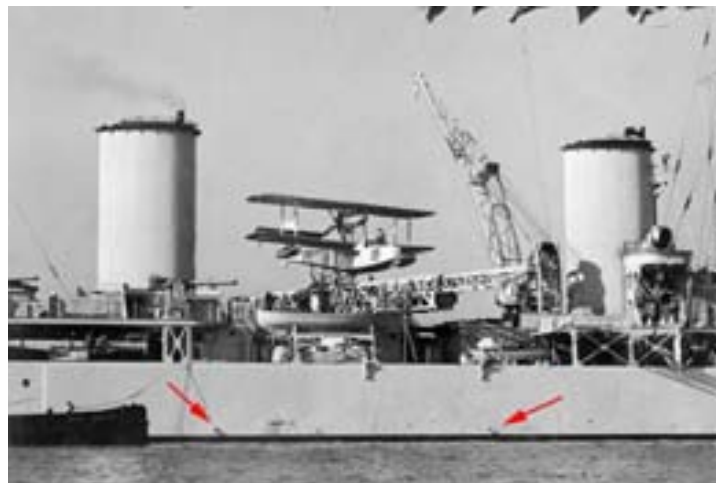

Figure 52: The arrows indicate upper-Deck scupper discharges on Sydney which have been fitted through the ship's side armour [97].

Engine Rooms and Boiler Rooms were fitted with drain sumps from which flood water in these spaces could be removed branches connected to a valve chest near the fire & bilge pumps. Bilge ejectors run off the auxiliary steam system were also fitted in the machinery spaces. Two were fitted in each boiler room and one in each engine room and they were capable of removing about 300 tons of water per hour.

The pumping, flooding and draining arrangements in Sydney were similar to those in all British cruisers. Figure 53 illustrates the arrangement of pumping, flooding and draining systems in a typical cruiser and the principle of the arrangement in Sydney was the same.

Sydney was also specified to carry a 100-ton portable submersible electrically-driven pump and one portable semi-rotary fire pump [85]. The location of the stowage for the 100-ton pump has not been identified.

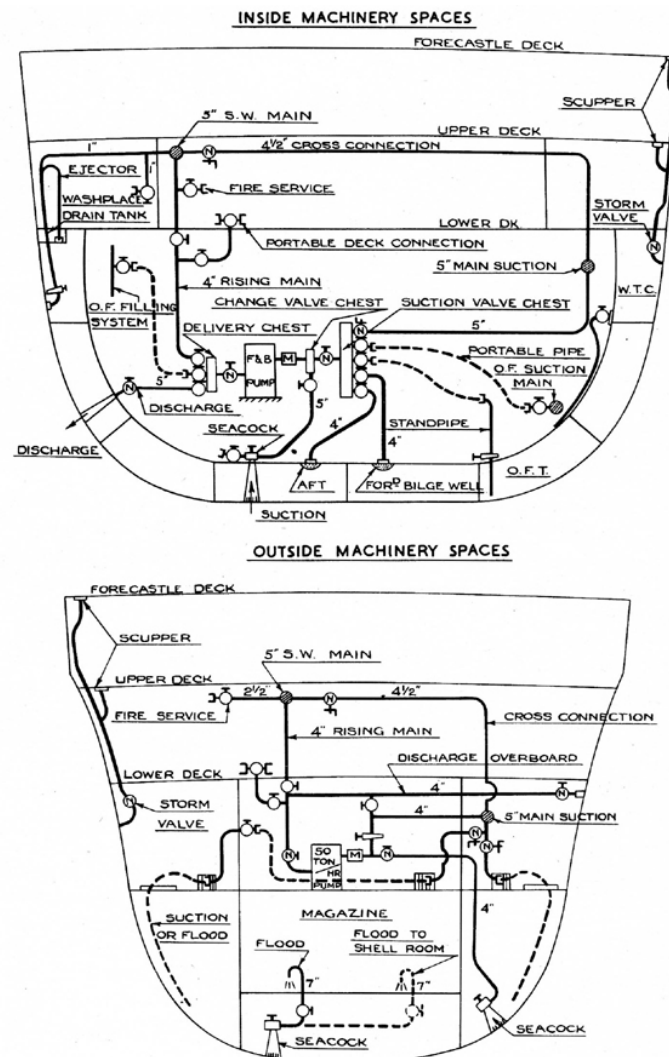

Figure 53: Pumping, flooding and draining services in a cruiser [90]

## 2.1.18 Ventilation

### 2.1.18.1 General description

The ventilation system provides fresh air to compartments within the ship and exhausts stale air (Figure 54). The Modified Leander Class specification [98], states the requirements for the ventilation system in *Sydney*, including:

- living and working spaces to be provided with forced supply and natural exhaust,
- ventilation fans to be electrically powered,
- compartments producing heat, water vapour, gases or odours to be fitted with natural supply and forced exhaust,
- inlets and outlets in open air,
- inlets and outlets to be placed as high as possible on structure,
- ventilation trunking made of light alloy sheet, steel where required to be watertight, and wood for those inside the transmitting station and W/T offices,

DSTO-GD-0559

- inlets and outlets must be able to be quickly closed from inside the ship, and provide circulation within the ship in case of action,
- watertight bulkheads cannot be penetrated by ventilation trunking below the lower deck, and
- trunking penetrating the platform deck or lower must be watertight or able to be made watertight by slide valves



Figure 54: Location of a typical ventilation inlet on the Fore-castle deck, port side [97]

Table 7 and



Table 8 list the supply and exhaust arrangements for the compartments on decks directly below the bridge.

Table 7: Supply Ventilation on Sydney [99]

| Compartment               | Deck          | Supply type (fan) | Supply location                                       |
|---------------------------|---------------|-------------------|---|
| Stoker's mess             | Lower deck    | Forced (B7)       | Flap, starboard side of Forecastle deck               |
|                           |               | Forced (B8)       | Flap, port side of Forecastle deck                    |
| No. 4 lower mess          | Lower deck    | Forced (B6)       | Flap, port side of Forecastle deck                    |
|                           |               | Forced (B5)       | Flap, forward side of superstructure                  |
| Switchboard room          | Platform deck | Forced (B8)       | Via Stoker's mess, flap, port side of Forecastle deck |
| 2nd W/T office            | Platform deck | Forced (A7)       | Flap, port side of Forecastle deck                    |
| L.P. switch room no. 2    | Platform deck | Forced (B7)       | Flap, starboard side of Forecastle deck               |
| Aux. W/T office           | Platform deck | Forced (A4)       | Flap, forward side of superstructure                  |
| Lower steering position   | Platform deck | Forced (A4, B5)   | Flap, forward side of superstructure                  |
| L.P. switch room no. 1    | Hold          | Forced (B7)       | Flap, starboard side of Forecastle deck               |
| Transmitting station      | Hold          | Forced (A5)       | Flap, port side of Forecastle deck                    |
| H.A. calculating position | Hold          | Forced (A5)       | Flap, port side of Forecastle deck                    |

DSTO-GD-0559

Table 8: Exhaust Ventilation on Sydney [99]

| Compartment               | Deck          | Exhaust type (fan) | Supply location   |
|---------------------------|---------------|--------------------|---|
| Stoker's mess             | Lower deck    | Natural            | Flap, starboard side Forecastle deck                              |
| No. 4 lower mess          | Lower deck    | Natural            | Mushroom Top (M.T.) vent between B turret and bridge              |
|                           |               | Natural            | Flap, starboard side Forecastle deck                              |
| Switchboard room          | Platform deck | Natural            | Vent to lower deck  |
| 2nd W/T office            | Platform deck | Natural            | Flap, port side of Forecastle deck                                |
| L.P. switch room no. 2    | Platform deck | Natural            | Vent to lower deck  |
|                           |               | Forced (B9)        | To open area, upper deck (battery ventilation)                    |
| Aux. W/T office           | Platform deck | Natural            | Flap, port side of superstructure                                 |
| Lower steering position   | Platform deck | Natural            | M.T. vent between B turret and bridge                             |
| L.P. switch room no. 1    | Hold          | Natural            | Vent to platform deck   |
| Transmitting station      | Hold          | Natural            | Flap, port side of Forecastle deck                                |
| H.A. calculating position | Hold          | Natural            | Vent to Transmitting station - Flap, port side of Forecastle deck |

### 2.1.18.2 Machinery space ventilation

The Boiler Rooms in *Sydney* operated with forced draught. The turbine-driven forced-draught fans were the primary means of ventilating these spaces and the air was exhausted up the funnels. A boiler room was also supplied with fresh air from a 12½" centrifugal fan located under the Forecastle Deck just forward of the forced-draught intake trunk. Engine Rooms were provided with ventilation supplied by electrically-driven supply and exhaust fans. The principal machinery space ventilation trunks and funnel hatches can be seen in Figure 55.

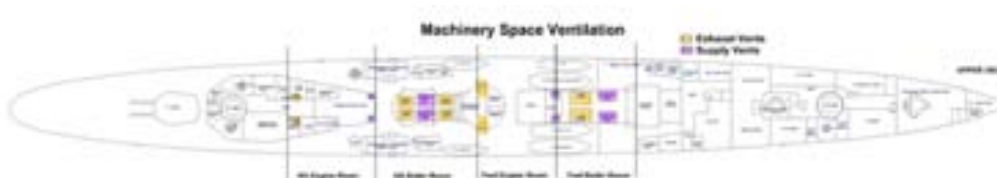

Figure 55: The machinery space ventilation supply and exhausts vents and funnel hatches on the upper deck.

### 2.1.18.3 Electrical System

#### 2.1.18.3.1 High Power System

The high-power electrical system supplied main lighting and machinery within the ship. It had up to four sources of supply; a steam-powered generator in the forward engine room, a steam-powered generator in the after engine room, and two diesel-driven generators in separate compartments on the Platform Deck [4]. Electricity was generated and distributed at 220 volts DC [100]. The high power distribution system was configured as a ring main, which was laid in cable passages (compartments between the machinery spaces and the ship's side) on the Platform Deck. These were within the

armour plating. Electrical practice was to enable the generators to supply either side of the ring main.

Ring Main Breakers (R.M.B. in Figure 56) and cross connections enabled the ring main to be divided into sections. Each section required a generator to be connected for electrical supply. The system could be used as a single section, divided into two, three or four sections.

Branch Breakers (B.B.) controlled the supply of high power to electrical branch lines. The branch breakers were located in the cable passages and in six breaker rooms on the Platform Deck. Equipment with high electrical demand would be supplied directly from a branch breaker, with less demanding equipment grouped to a branch breaker via a junction box. The system could be controlled and monitored at the Switchboard Room. The Switchboard Room was connected to the high-power system by control cables [101]. Control could also be carried out locally, by opening or closing the breakers.

Breakers would open automatically in the case of electric fault, such as an overload or explosive shock. If a supply breaker (at the Dynamo) opened then the entire section would lose electrical power, in which case the fault would need to be found and isolated before power could be restored.

Naval ships of this era could make use of emergency electrical cables and through-bulkhead electrical connectors. This enabled branch breakers to be supplied by emergency cables if the ring main cables were damaged without compromising the water tight integrity. There were sufficient through bulkhead electrical connectors to enable an emergency main to be rigged in case of damage to the fixed ring main.

The general design of the system is shown in Figure 56.

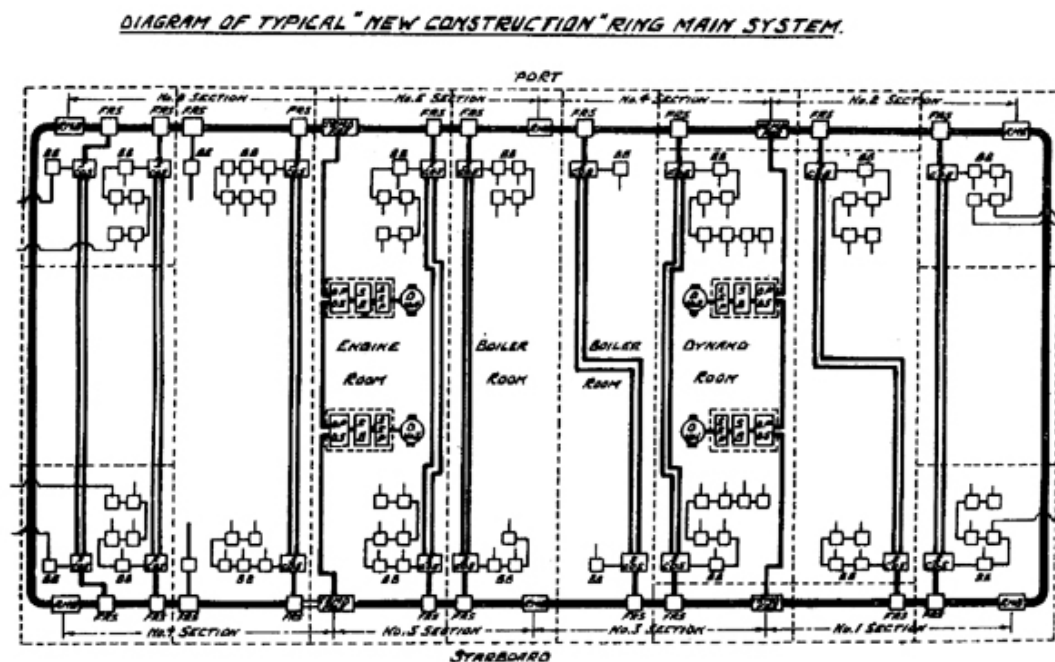

Figure 56: General high power ring main layout

DSTO-GD-0559

#### 2.1.18.4 Low Power System

Low power was produced from Motor Generators supplied from the high power system. It was configured in a ring main, could be subdivided, and contained battery backup in case low power generation was lost. The low power system supplied the telephone system, gyro compasses and gun fire control instruments [98].

## 2.2 Communication Systems

*Sydney* had a number of external and internal communication capabilities. For internal communications there were voice pipes between different areas of the ship, as well as electrical telephones. For external communications with the outside world there was Wireless Telegraphy (W/T), signal lamps and a semaphore system. The following describes the capability of each of these communication systems.

### 2.2.1 Internal Communication

The internal communications on *Sydney* was mostly from the Bridge, and again mostly for firing and control of weapons.

Pneumatic Tubes were used to send paper messages in both directions [102], mainly from the Coding Office ( aft, Lower deck) to:

- Remote Control Office
- Signal Distribution Office
- 2nd WT Office
- Aux WT Office
- Remote Control Office to Wheel House and Aux WT Office

From the upper Bridge, the crew on the bridge were able to communicate via voice pipe (copper tubes) to the Signal Deck of the Superstructure, and the lower Bridge, as well as the Director Control Tower and HACS.

There were wired phones from the upper Bridge to:

- High Angle Control Position
- Fire Control Exchange
- Ships Exchange
- After Control Position
- Aft Machine Gun
- Main Coding Office
- DCT

On the Lower Bridge there were phones to:

- Ship's Exchange
- Fire Control Exchange
- Torpedo Crews Shelter Port

From Transmitting Station there were telephones to [103]:

- 2nd W.T. Office
- Ship Telephone Exchange
- Fire Control Exchange
- Director Control Tower
- 'A' and 'B' Turret and DCT
- 'X' and 'Y' Turret

The Telephone Exchange served as communications hub to the Lower Steering Position, or the damage control headquarters (DCHQ) at Action Stations. To convey the information from remote parts of the ship the telephone crew would need to send a messenger up a deck and forward then down a deck to inform the DCHQ, as there was no direct access through the bulkhead 76 between them.

### 2.2.2 Ship to Shore

*Sydney* had three W/T offices on board to handle communication with the outside world. Although during wartime the ship would have maintained strict radio silence, the W/T offices would have been receiving signals from allied naval stations on the movements of ships and other naval related correspondence [104]. The Main W/T Office was sited on the Lower Deck at frames 144 to 151, on the centre link between Breaker Rooms [105]. The Main W/T Office was directly below the main mast and aft superstructure (see Figure 34). This compartment was not behind the armour plating that protected the engine rooms, but it was mainly located in the centre of the ship, which would have provided some level of protection from shell damage. The aerial trunk (which contained all the wiring to the aerials) was also located in the centre of the ship and went up through the aft superstructure to the main mast. The Main W/T Office was fitted out with a Type 48 transmitter. This was able to transmit over long distances, and during commissioning trials it was able to transmit from Wallsend-on-Tyne to Bermuda, a distance of over 5000 km [62]. It was only capable of Continuous Wave (CW) transmission, meaning that it could only send Morse coded messages [107].

The Secondary W/T room was at frames 81 to 84, on the centre link between Breaker Rooms (see Figure 35) [108]. The aerial trunk for this W/T office came up through the ship to an aerial trunk beside the blacksmiths shop on the port side on the Forecastle Deck. The aerial cables then went up the forward mast, which was located on the top of the Blacksmiths Shop. This office was fitted out with a Type 49 transmitter, which was again capable of CW transmission, but this transmitter was much less powerful than the Type 48 transmitter in the Main W/T Office. During commissioning trials, the Type 48 was only able to reach Malta from the Wallsend-on-Tyne dockyard, a distance of under 2300 km [62]. The drawing for the Secondary W/T Office shows a space for a small Type 6F transmitter, but this transmitter was only able to transmit under 160 km during commissioning trials [62].

The Auxiliary W/T Office was just forward of the Secondary W/T Office, also located on the Platform Deck (see Figure 35). According to the 'as fitted' plans for *Sydney*, the Auxiliary W/T office contained both Type 45 and Type 43a transmission sets. The aerial trunks for these transmission sets ran up either side of the bridge. Both of these sets were very low power, and during commissioning transmitted under 80 km. The Auxiliary transmission office was generally used for ship-to-ship communication when manoeuvring a fleet, squadron or flotilla [104]. These sets could also only be operated in a CW mode.

The aerials were fitted in place with cable stays, which had brown vitrified porcelain isolators fitted to isolate them from the ship. The forward aerial mast emerges on the Forecastle, near the centreline over the Gunners' R.U. Store, as part of the Aft DC tower, at frame 146. The aft aerial mast emerges on the Forecastle, port and aft of Smith Shop, at frame 87. The Main Aerial lines were strung between the two masts, from spars on the

DSTO-GD-0559

both masts, and also connected between the superstructure and the masts as seen in Figure 57.

In a mid-1941 Alteration and Additions list for *Sydney*, the addition of standard emergency W/T set Type 60E was requested. Although this was approved, it was not possible to fit this transmitter due to “a lack of material” [109].

Batteries for the W/T sets were approved to be fitted with shock insulating devices [109]. This shows that there was some concern over the ability of the W/T equipment to survive shock loading due to underwater explosions.

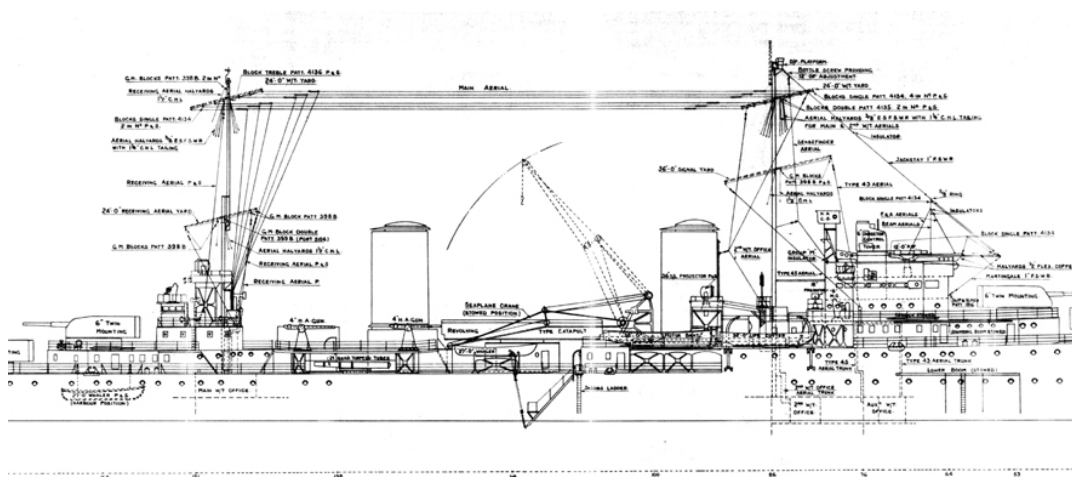

Figure 57: Diagram of W/T Office Location and Aerial Trunks [110]

### 2.2.3 Ship to Ship

The Auxiliary W/T Office was used for communication between ships. *Sydney* was also fitted with flag, semaphore and signal lamps for ship-to-ship communication.

## 2.3 Lifesaving Equipment

### 2.3.1 Carley Floats

Carley floats were carried on RAN vessels as part of the ship’s lifesaving equipment. They came in a number of sizes and were considered as providing a very important emergency or secondary role in lifesaving (after the ships boats). They were in fact oversized lifebuoys.

Carley floats were designed to float either way up and consisted of a large diameter copper tube formed into an oval ring divided by bulkheads into a number of watertight compartments. The tube was covered with a layer of cork parcelled with painted canvas. A platform of slatted wood was slung from the inner edge of the tube by rope netting and a life line was fitted around the outside of the tube [111]. They were normally lashed to the deck or to other structures with ropes or wire.

Carley floats were an American design and were originally manufactured by the Carley Life Float Company in Cambridge Massachusetts USA. The original patent for a “Life Boat” was granted to Horace S. Carley in July 1899 and improvements to increase the strength, durability and carrying capacity were patented in July 1903 (Figure 58) [112]. These became colloquially known as Carley Floats and the latter design was the basis of the Carley floats used on RN and RAN ships during WW II along with the navies of the United States, Canada, Italy and Russia [113]. In Britain the floats were officially adopted in April 1915 and fitted to the majority of its warships [114]. In the UK Carley floats were manufactured by Notts Industries (Somerset) and although they were also manufactured in Australia, records of the companies who manufactured them have been lost.

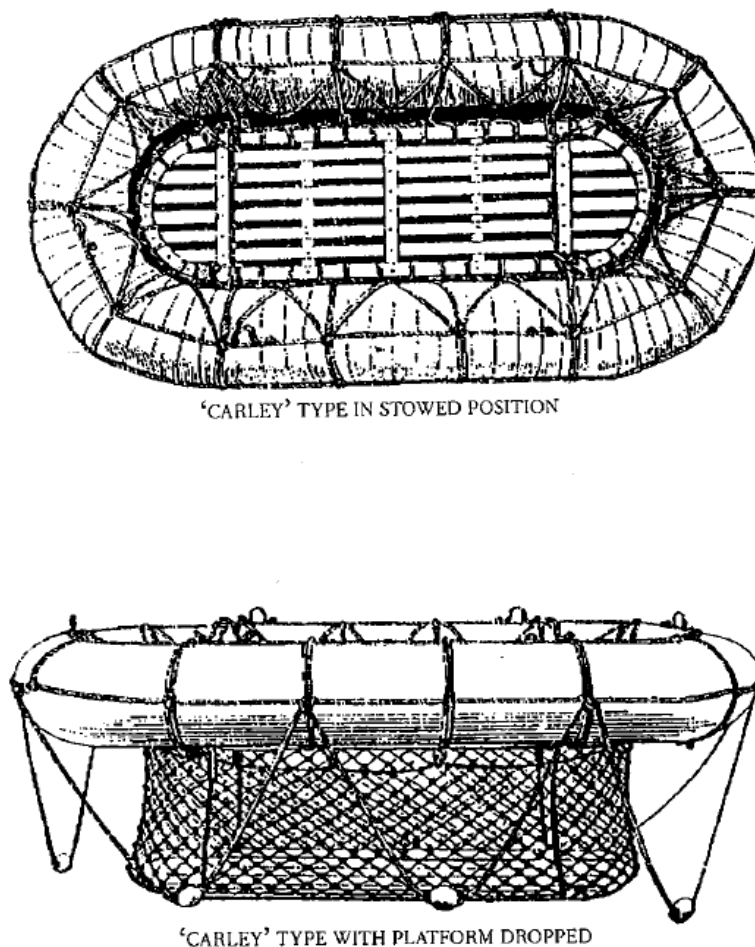

Figure 58: Typical Carley float design as per US Patent 734,118 [112]

As completed, in September 1935 *Sydney* was equipped with a “peacetime” allocation of Carley floats as shown in Table 9. Further details of these Carley floats are shown in Table 9 along with the specified “allowed persons” or lifesaving capacity and the weight of the respective floats. It should be noted that the Pattern 17 and 18 floats were by no means light, weighing 322 kg and 406 kg respectively. Despite their weight (and size), they were expected to be manhandled over the side of the ship. The lifesaving capacity

DSTO-GD-0559

in Table 10 needs to be further clarified as it comprises those people inside the Carley float and those that were clinging to the becketed ropes/lines that were wrapped around the outside of the float tube. The first number in brackets indicates the number of people inside the float and the second number is the number of people clinging to the beackets of the lifelines [115].

Table 9: Initial Allocation of Carley Floats on Sydney [66, 113, 127]

| Number | Pattern Number | Lifesaving Capacity |
|--------|----------------|---------------------|
| 2      | 17             | 2 X 45              |
| 2      | 18             | 2 X 67              |
| 2      | 20             | 2 X 20              |

Table 10: Details of Carley Floats [113]

| Pattern Number | Size         | Dimensions of Tube | Weight (kg) | Lifesaving Capacity |
|----------------|--------------|--------------------|-------------|---------------------|
| 17             | 8 ft X 12 ft | 19"                | 322         | 45                  |
| 18             | 9 ft X 14 ft | 20"                | 406         | 67                  |
| 20             | 5 ft X 10 ft | 15.5"              | 175         | 20 (12 +8)          |

The location, type and numbers of Carley floats varied significantly from the time that *Sydney* was commissioned and joined the Mediterranean fleet in November 1935 until *Sydney* was sunk in November 1941. Initially, the Carley floats also appear to have been numbered and photos exist of Carley floats on *Sydney* with a large number painted horizontally on the side (Figure 59 and Figure 60). The Carley float recovered by HMAS Heros on 28 November during the search for survivors of *Sydney* [116] had the number 5 painted on its side and is believed to have come from *Sydney* [117]. However, there are no photos of Carley floats, apart from those shown in Figure 59 and Figure 60 that show any evidence of a number painted on their side.



Figure 59: Carley float tied down on 4" gun deck between 4" guns and outboard of the ready use locker; starboard side of Sydney, November 1935. Note number 3 painted on side [118].



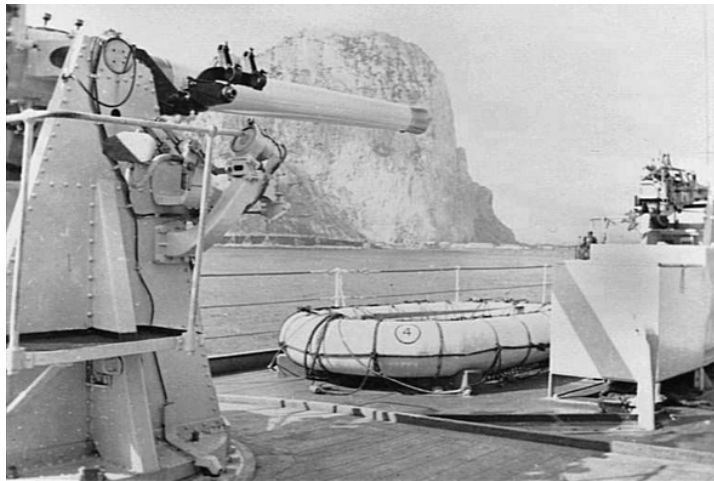

Figure 60: Carley float tied down on 4" gun deck between 4" guns and outboard of the ready use locker; port side Sydney, November 1935. Note number 4 painted on side [119].

It has been suggested that the numbering of the Carley floats started on the Forecastle and proceeded aft and the odd numbered floats were on the starboard side and the even numbers were on the port side [117]. This is supported by the numbering shown in Figure 59 and Figure 60.

The location of the floats onboard *Sydney* is uncertain but from various photographs it may be conjectured that they were distributed around the ship in various locations and in various quantities. Before the war commenced, there were two floats on the 4" gun deck between the guns and outboard of the ready use lockers as shown in Figure 59 and Figure 60. These are believed to have been Pattern No. 17 floats [2, 113]. Other photographs show that the larger Pattern No. 18 floats were stored horizontally and tied to the timber stowage rack between the starboard and the port 4" gun decks (Figure 62). The final two floats, the Pattern No. 20's, were stored on the boiler room vent forward of the forward funnel [2, 74, 114], but there are no known photographs of this storage position.

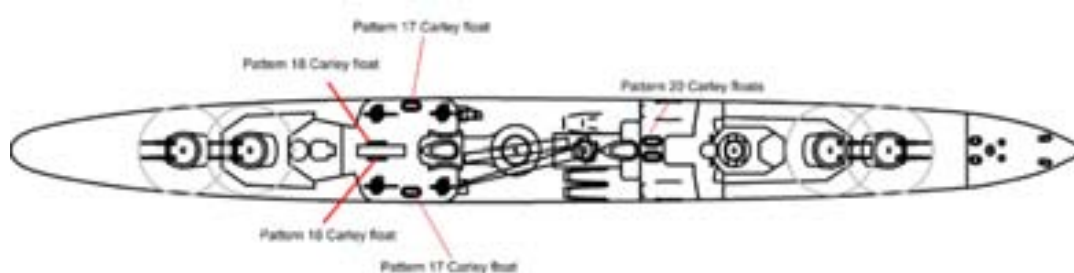

Figure 61: Initial location of Carley floats aboard Sydney

DSTO-GD-0559

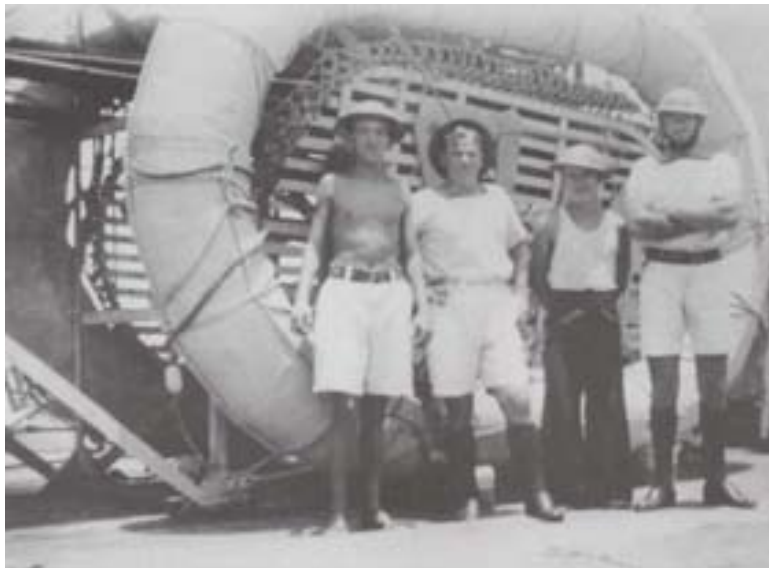

Figure 62: 1939-1940, Pattern No. 18 Carley float stowed on the timber stowage rack on the 4" gun deck between the port and starboard guns [2, 113].

It has been claimed that Carley floats were rotated around the fleet and were not issued exclusively to one ship [120]. For example, for a ship undertaking a refit, the lifesaving equipment was landed ashore and surveyed before being returned. However, since the surveying was done on a pool basis, the ship was not guaranteed to receive back the equipment that had been landed.

At the outbreak of war and during the time *Sydney* was deployed to the Mediterranean, the crew increased but there is no evidence to show that the number of Carley floats increased accordingly [74]. It was only later that the numbers increased. However the locations of the Carley floats changed as can be seen in Figure 63. Figure 63 shows two Carley floats (probably Pattern No. 18) on the stern. It also shows what appear to be objects inside both Carley floats but it is unclear exactly what these were. Other photos around this time do not appear to show any Carley floats on the stern and perhaps this was only temporary and after the time in the Mediterranean, the floats were relocated elsewhere.



Figure 63: The stern of *Sydney* in June 1940. Photograph taken in the Mediterranean during action with the Italian cruiser *Bartolomeo Colleoni* [121].

DSTO-GD-0559

Figure 64 shows that there was another change to the float locations pre-July 1940 where there were two large Pattern No. 18 Carley floats stored horizontally on the timber stowage rack on the port side (and possibly two more on the starboard side).



Figure 64: HMAS Sydney pre-July 1940 showing two Pattern No. 18 Carley floats on the timber stowage rack [122]

The 30' Gig also appears to have been replaced sometime before May 1940 with at least one large Pattern No. 18 Carley float (Figure 65). Figure 65 possibly shows another Carley float in the foreground but it is difficult to determine its size. It would appear that the Gig was not simply relocated but was removed from the ship completely.



Figure 65: Aden May 1940, Sydney looking aft showing possibly one large Pattern No. 18 Carley float on the port side in place of the 30' Gig [123]

Sydney was repainted with new camouflage colours in February/March 1941 and from early 1941 until November 1941, the locations of the Carley floats and the number of floats again varied considerably. In early 1941 the two large Pattern No. 18 floats on the timber stowage rack were replaced with four smaller Pattern No. 20 floats, two floats on each side. They were usually lashed to the rack in a vertical direction (Figure 66). The two large Pattern No. 18 floats were re-located to the stern on the quarterdeck and another smaller Pattern No. 20 float was fitted inside the starboard Pattern No. 18 float

DSTO-GD-0559

(Figure 66 and Figure 67) [114, 117, 124]. It is thought that part of the reason for the change was to relocate the larger and heavier Pattern No. 18 floats to a position where it would be easier to manhandle them off the ship — at the stern. Figure 68 provides further evidence for the Carley floats on the stern with a photograph of sailors painting a Carley float on the stern. The number of floats also increased with Pattern No. 18 floats being replaced with more of the smaller Pattern No. 20s. Along with these changes, Figure 69 shows that two Pattern No. 20 floats replaced the large Pattern No. 18 that was in the location originally occupied by the 30' Gig [74].



Figure 66: *Sydney* in August 1941 showing Carley floats on the stern and 2 vertical floats on the starboard side on the timber stowage rack [125].



Figure 67: *The stern of Sydney* in September 1941 showing the location of the two Pattern No. 18 Carley floats with a Pattern No. 20 Carley float inside the starboard No. 18 float [126].

Carley floats were not normally equipped with provisions such as water, food or paddles but later in the war it would appear that small containers or casks of water were lashed inside the floats. Some photographs show long cylindrical containers in the floats, which are believed to be salvaged 6" cordite cases, which had watertight caps

DSTO-GD-0559

[117]. None of the photographs here show such items with the possible exception of Figure 63.



Figure 68: February 1941, stern of Sydney showing sailors painting a large Carley float [113]

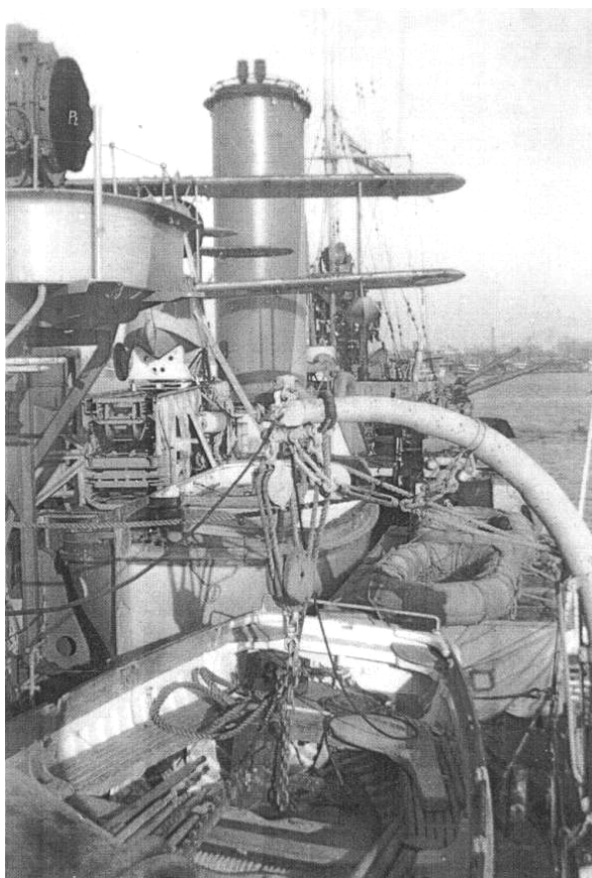

Figure 69: Late 1941, port side of Sydney looking aft showing two Pattern No. 20 Carley floats in place of the 30' Gig [122]

DSTO-GD-0559

The photographic evidence suggests that in November 1941, *Sydney* had the following Carley floats on board that provided a lifesaving capacity of 274 (Table 11).

Table 11: Allocation of Carley floats onboard *Sydney* in November 1941

| Pattern Number | Number | Location   | Lifesaving Capacity [66, 127] |
|----------------|--------|--|-------------------------------|
| 18             | 2      | Stern  | 134                           |
| 20             | 1      | Stern  | 20                            |
| 20             | 2      | Starboard, timber stowage rack                             | 40                            |
| 20             | 2      | Port, timber stowage rack                                  | 40                            |
| 20             | 2      | Port, in place of the 30' Gig outboard of the 36' Pinnacle | 40                            |

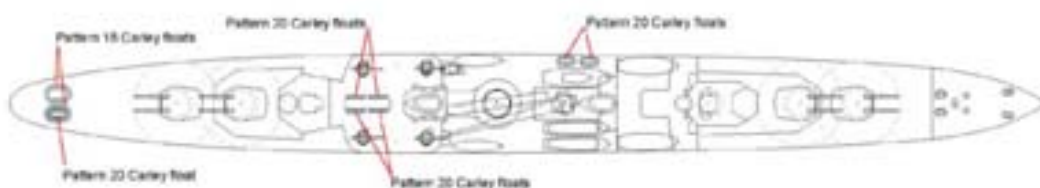

Figure 70: Position of Carley floats on *Sydney* in November 1941

### 2.3.2 Ships Boats

As fitted, *Sydney* was equipped with a range of boats as part of the life saving equipment on board. The initial allocation of boats is shown in Table 12 along with the details of the size and life saving capacity.

Table 12: Initial Allocation of Boats on *Sydney* [106, 117, 127]

| Boat Type                  | Number | Length (ft) | Total Weight |             | Lifesaving Capacity |
|----------------------------|--------|-------------|--------------|-------------|---------------------|
|                            |        |             | tons         | kg (approx) |                     |
| Motor Pinnacle             | 1      | 35          | 5.59         | 5676        | 46                  |
| Motor Boat                 | 1      | 35          | 5.57         | 5659        | 42                  |
| Motor and Sailing Pinnacle | 1      | 36          | 5.95         | 6045        | 76                  |
| Sailing Cutter             | 2      | 32          | 4.23         | 4267        | 118                 |
| Gig                        | 1      | 30          | 0.85         | 864         | 26                  |
| Whaler                     | 2      | 27          | 0.98         | 996         | 54                  |
| Skiff Dingy                | 1      | 16          | 0.47         | 478         | 7                   |
| Balsa                      | 1      | 10          | 0.26         | 264         | 6                   |

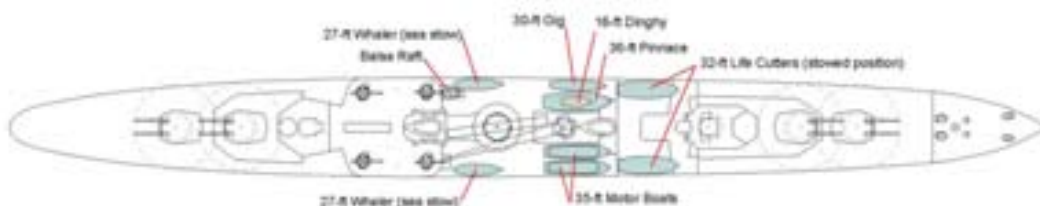

Figure 71: Position of boats on *Sydney* as completed

As has been seen with the Carley floats, the number and type of boats on *Sydney* varied from 1935 until November 1941.

The boat described as 'Balsa' would have been a Balsa Raft, Pattern No. N10505. It was a simple craft of wooden cask construction for the use of the side party when painting ship etc [111]. It was stowed on top of the Vegetable Store and Preparing Space on the port side [2].

The Skiff Dingy is drawn on several of the ship drawings [3] and Figure 69 shows a view of the port side looking aft with a small dingy inside a larger boat inboard of the two Carley floats. The larger boat is believed to be the 35' Motor and Sailing Pinnace and the small boat is possibly the 16' Skiff Dingy. However, it has been stated that the Skiff Dingy was replaced with a 16' Vosper motor boat, or a Jolly Boat after 1938 [74]. The existence of the Jolly Boat is also noted in other references [77, 114] and so the small boat in Figure 69 is likely the 16' Jolly Boat. It is also noted that during the engagement with the Italian cruiser Bartolomeo Colleoni in July 1940, there is a report of the Skiff being damaged by shellfire [128]. This suggests that there was a small boat aboard *Sydney* but its exact nature is still in question.

Figure 69 also shows the aft end of the 32' Life (Sailing) Cutter which is on davits. The Life Cutter was stowed inboard when in port and was swung outboard when at sea. Figure 72 shows the port side aspect of *Sydney* whilst alongside (possibly in Alexandria) post July 1940 [122] and the 32 Cutter can be seen stowed on its davits forward of the forward funnel. The 35' Motor and Sailing Pinnace can be seen aft of the Cutter along with two Carley floats horizontally placed outboard of the Pinnace. These Carley floats are located where the 30' Gig is shown on drawings of *Sydney* [3]. It is proposed that the Gig was removed rather than relocated sometime before May 1940 as no evidence can be found of it on any photographs. The 27' Whaler can be seen underneath the seaplane, which is sitting on its launch catapult.

Figure 73 also shows the boats on the port side although only a small part of the 35' Motor and Sailing Pinnace is visible [122].

Figure 74 shows the starboard side of *Sydney* in August 1941 [125]. The 32' Life Cutter is clearly seen swung out on its davits between the forward funnel and the High Angle Control Station. Directly aft of the Cutter are the two 35' Motor Boats along with the 27' Whaler further aft in line with the seaplane. It would appear that by this time, the 36' Motor Pinnace was replaced with another 35' Motor Boat. Figure 75 shows the starboard side of *Sydney* looking forward from the 4" gun deck which shows the two 35' Motor Boats stowed and secured with their "bottle crew stops" [122].

From these photographs, the number, location and life saving capacity of the ships boats for *Sydney* in November 1941 is believed to be as given in Table 13. The total life saving capacity of the ship's boats was 342 persons.

As noted above, all the ship's boats, with the exception of the 32' Life Cutters which were on davits, required the ships crane to lift them over the side of the ship.

DSTO-GD-0559

Table 13: Type and distribution of Ships Boats on Sydney at November 1941

| Boat Type                        | Number | Location  | Life Saving Capacity |
|----------------------------------|--------|---|----------------------|
| 36 ft. Motor and Sailing Pinnace | 1      | Port side, abreast forward funnel                                     | 76                   |
| 35 ft. Motor Boat                | 2      | Starboard side, abreast forward funnel                                | 84                   |
| 32 ft. Life (Sailing) Cutter     | 2      | One each starboard and port side, forward funnel                      | 118                  |
| 27 ft. Whaler                    | 2      | One each starboard and port side, abreast seaplane catapult turntable | 54                   |
| 16 ft. Jolly Boat or Skiff       | 1      | Port side, in Motor Pinnace   | 10                   |

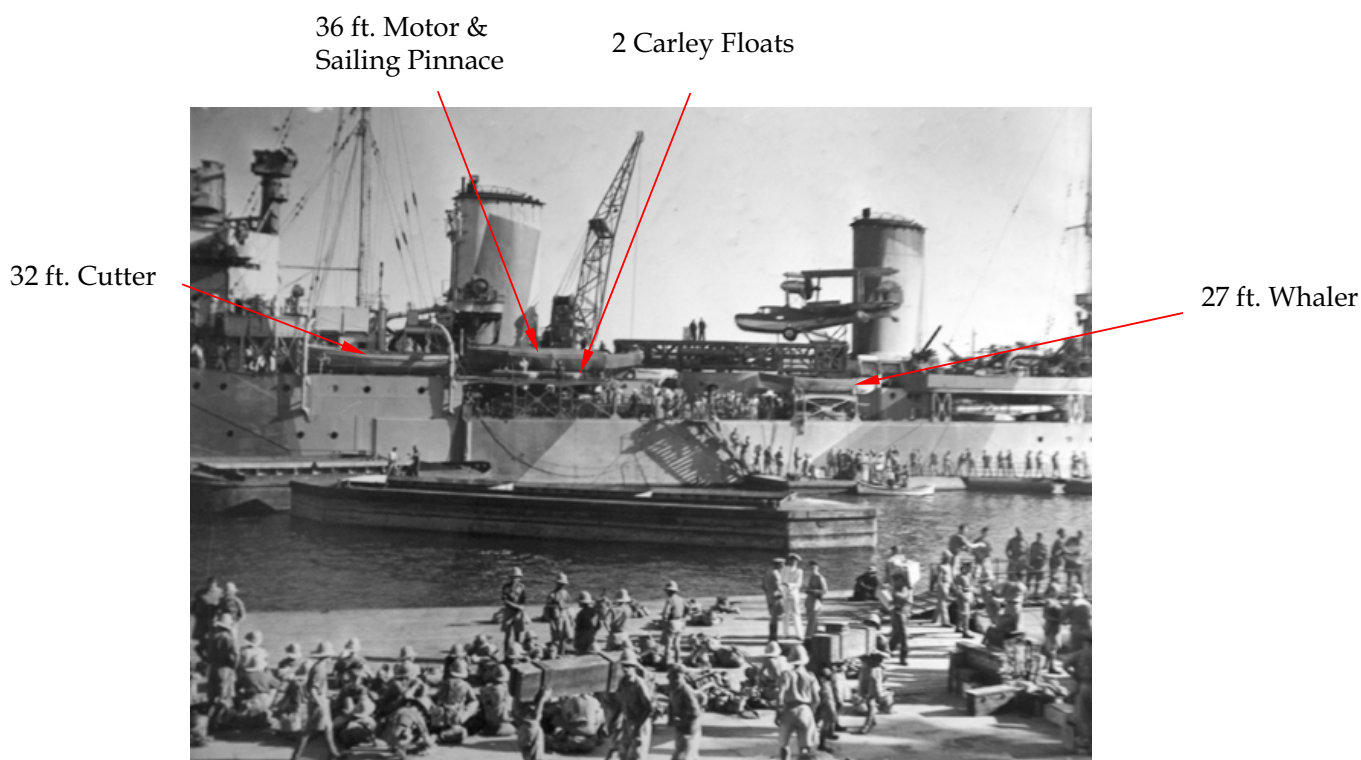

Figure 72: Port side of Sydney alongside somewhere in the Mediterranean, post July 1940 [122]



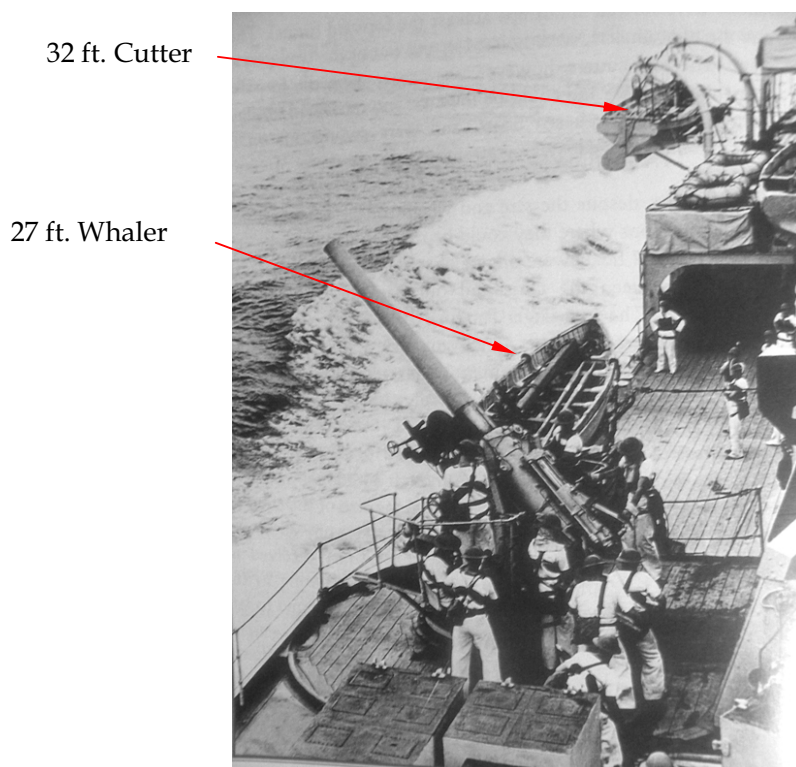

Figure 73: Port side of Sydney pre 1940 looking forward from the 4" gun deck [74, 122]

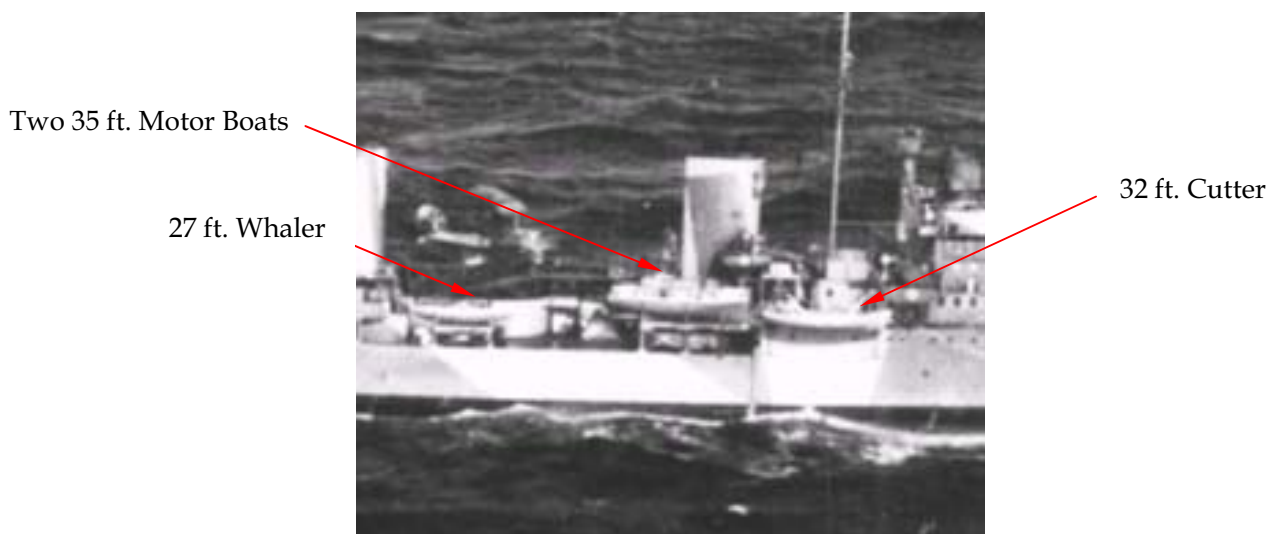

Figure 74: Starboard side of Sydney in August 1941 showing the location and number of boats [125]

DSTO-GD-0559



Two 35 ft. Motor Boats

Figure 75: Starboard side of Sydney post July 1940, looking from the 4" gun deck forward showing the two 35' Motor Boats [122]

### 2.3.3 Other lifesaving equipment

All crew on *Sydney* were issued with personal inflatable life belts. These were simply a rubber tube coated with a fabric and were supposed to be worn over the shoulder and secured with tape around the body. They were to be worn in the deflated state when at action stations and were to be inflated before entering the water (abandoning ship). However, most crew wore them around their waist, considered them of little use and the USN found that they often wore out prematurely due to the constant rubbing of the deflated belt around the waist [117]. These belts were designed to keep an individual afloat for very short periods of time – hours at the maximum. There was a significant danger that when floating the wearer would doze off and flip over and drown. The floatation aid also did not keep the wearer's mouth above water if they became unconscious [111].

Many HM ships carried Floatanets, which were large nets made buoyant with cork floats attached but RAN ships did not carry these.

It is claimed that *Sydney* also carried a number of lifebuoys. Photographs are claimed to show two abaft the torpedo space and two more on the forward superstructure [74]. Figure 76 is an enlargement of the forward superstructure of *Sydney* pre-July 1940. It shows a life buoy on the forward superstructure outside of the Recreation Space on the Forecastle deck on the port side [122]. Other photographs show a similar single lifebuoy on the starboard side but no evidence can be found for any others on other locations on *Sydney*. It is known, however, that it was Admiralty practice to issue cruisers with two Kisbie lifebuoys. They were to be placed aft, one on each side of the ship, under the charge of a lifebuoy sentry, for use in case of a man overboard. Photos of other British cruisers taken during WWII show lifebuoys on the guard rails abeam Y turret (near the accommodation ladder) or on the nearby deckhouse side [67]. Ceremonial lifebuoys, painted with the ship's name and crest, are commonly found in naval ships. If they were carried in *Sydney* they may have been stowed in the Quartermaster's Lobby in the after superstructure for safe keeping.



Figure 76: Photograph of Sydney port side showing single Kisbie lifebuoy on the forward superstructure [122].

It is also claimed that the hammocks that the crew slept in were stored in bins in such a manner that if the ship sank, they would float. Crew were directed that clinging to such a net would keep a person afloat for up to 45 hours [124].

A further device has been referred to as a “Hilken Raft”. These appear to have been a device that was constructed of two sealed up large food tins that were then sealed into a pine box. Two of these boxes were joined together by four pieces of pine wood and hoops of rope. They were secured around the upper decks in the same manner as the Carley floats [129]. Again, no evidence for these items has been found.

#### 2.3.4 Modifications after completion and Proposed Modernisation

A number of modifications were made to *Sydney* during refits after arrival in Australia (Figure 77). Most were minor, and did not significantly change the configuration of the ship. During WWII some protection was provided to the 4” gun crews by 20 lb steel plates fitted to the guardrails around the gun deck. Many of the sidelights on the Lower Deck were plated over to reduce vulnerability to damage and flooding risk and the ship was fitted with degaussing cables around the upper Deck.

HMAS Hobart and HMAS Perth (whilst in RN service) had been modernised during refits in 1938 when the single 4” guns were replaced by twin 4” Mk XIX high angle gun mountings to improve anti-aircraft capability. Similar changes were intended for *Sydney* during a modernisation refit planned for December 1939 to March 1940 in Sydney. In October 1939 her modernisation refit (and that of HMAS Canberra) was deferred indefinitely [130].

DSTO-GD-0559



*Figure 77: Sydney as she appeared on her return to Sydney from the Mediterranean on 10 February 1941 [131]*

## 3. Operational Aspects of HMAS Sydney

### 3.1 General Organisation

Documentation specifying the British Navy's Damage Control procedures for WWII has not been found. While the details of the US Navy Damage Control organisation may differ from the British Navy practices of the time, the philosophy was similar. Practice and equipment for the British Navy and RAN are similar today. From the US Handbook of Damage Control, 1945, Chapter XXII on Damage Control Organization [132]:

*A ship's organization for battle usually is divided into four primary controls: fire control, ship control, engine control, and damage control. Carriers have flight control in addition.*

At Action Stations, or First Degree of Readiness, all crew are detailed an active position, or Closed Up, as engagement with the enemy is imminent. The ships' Watertight doors and hatches are all closed, from the Hold up to the Forecastle. Guns are armed and trained on the enemy.

As the Watch and Station Bill for *Sydney* has not been found, the crew whereabouts has mostly been assumed from Rank [133] and from COI correspondence about upper Deck allocations. Assumptions have based on information from Damage Control Organisation.

#### 3.1.1 Command and Control

Command of the ship was from the Bridge and upper Bridge. This area contained the majority of senior officers for decision making on navigation and ship movement, attack or gun control. Most internal communication phones, etc. ran to the Bridge. The Bridge superstructure also housed the signal men, and the DCT crew for 6" gun sighting, in all about 20 crew members [134]. At Action Stations, the Lower Steering Position was fully manned to take over command for these decisions in the event that the Bridge Superstructure was taken out of action, although its main function was to supervise damage control proceedings.

#### 3.1.2 Crew Locations at Action Stations

The likely locations of the crew of *Sydney* at action stations are indicated in Table 14. The open decks contained about 170 crew, including the crew from the Bridge area. This included the Flag deck and Searchlight platforms, DCT, HACS, Aft Control Position, aircraft area; and the torpedoes, 6" gun turrets, 4" guns, machine guns and the Quarterdeck for the depth charges. Below decks all the magazines and loading zones for the 6" and 4" guns would have been manned, with about 36 and 30 crew members respectively. All the wireless and telephone rooms would have contained about 25 men.

DSTO-GD-0559

Table 14: List of occupations and ranks of Sydney personnel, and likely locations at Action Stations

| OCCUPATION                          | No. | Location   | OCCUPATION                          | No.            | Location   |  |
|-------------------------------------|-----|--|-------------------------------------|----------------|--|--|
| Captain                             | 1   | Bridge   | Warrant Officer Gunner T            | 1              | DCT, rear cmpt                                       |  |
| Commander                           | 3   | 3 in Bridge superstructure; 3 in DCTower, 1 at Aft Control Position; 1 in Lower Steering Position  | Gunner                              | 1              | 4" gun deck  |  |
| Commander (E)                       | 1   |  | Chief Ordnance Artificer            | 1              | 6" Magazine; 1 to DC2                                |  |
| Lieutenant Commander                | 1   |  | Ordnance Artificer                  | 5              |  |  |
| Lieutenant-Commander (E)            | 1   |  | Acting Ordnance Artificer           | 1              |  |  |
| Lieutenant-Commander (O)            | 1   |  | Medical Post                        | Master-At-Arms | 1  | 4" gun deck  |
| Chaplain The Reverend               | 1   | 4 in DCT; 5 in HAC Station; 8 on 6" guns; 4 per 6" Magazine  | Surgeon Lieutenant Dentist          | 1              | Medical Post, Sick Bay, First Aid                    |  |
| Lieutenant                          | 6   |  | Surgeon Commander                   | 1              |  |  |
| Sub-Lieutenant                      | 4   |  | Surgeon Lieutenant-Commander        | 1              |  |  |
| Chief Petty Officer                 | 4   |  | Acting Leading Sick Berth Attendant | 1              |  |  |
| Petty Officer                       | 11  |  | Sick Berth Attendant                | 5              |  |  |
| Acting Petty Officer                | 6   | 2 on Torpedoes; 4 on guns; 2 Bridge runners, 15 per 6"gun; 6 on searchlights; 2 on Aft Control position; 3 in each of 4 Cordite rooms; 5 Aft Steering Cmpt ; 28 on 4" Gun deck; 4" Mag; 10 per 6" Ammo lobby; 9 on Machine Guns; 5 as messengers- Transmission Rooms; 5 HACP; 4 on Quarterdeck; remainder at DC/Medical Post | Sick Berth Petty Officer            | 1              | Repair Parties, Lower/platform decks                 |  |
| Leading Seaman                      | 6   |  | Chief Shipwright                    | 1              |  |  |
| Acting Leading Seaman               | 11  |  | Warrant Shipwright                  | 1              |  |  |
| Able Seaman                         | 181 |  | Shipwright                          | 4              |  |  |
| Acting Able Seaman                  | 1   |  | Acting Shipwright                   | 1              |  |  |
| Ordinary Seaman                     | 58  | DC Station   | Chief Mechanician                   | 1              | DC2  |  |
| Painter                             | 1   |  | Mechanician                         | 3              |  | DC2/1 per Engine Room  |
| Plumber                             | 1   |  | Warrant Electrician                 | 1              |  | switch room  |
| Blacksmith                          | 1   |  | Chief Electrical Artificer          | 2              |  | Torpedoes  |
| Joiner                              | 1   |  | Electrical Artificer                | 3              |  |  |
| Schoolmaster                        | 1   | DC /medical post Lower Deck  | Acting Electrical Artificer         | 2              | Diesel Dynamos, Lo & Hi Power Switch Rooms, 2 to DC2 |  |
| Leading Steward                     | 4   |  | Lieutenant Engineer                 | 2              |  |  |
| Steward                             | 10  |  | Sub-Lieutenant Engineer             | 2              |  |  |
| Assistant Steward                   | 4   |  | Warrant Engineer                    | 3              |  |  |
| Petty Officer Steward               | 2   |  | Chief Engine Room Artificer         | 3              |  | Engine Rooms, DC2  |
| Flight Sergeant                     | 1   | upper deck near airplane   | Engine Room Artificer               | 13             | Engine/Boiler Rooms; 1 per Breaker Room              |  |
| Flying Officer                      | 1   |  | Acting Engine Room Artificer        | 6              |  |  |
| Leading Aircraftsman                | 4   |  | Chief Stoker                        | 4              |  | 5 on catapult; 2 per Pump room; remainder in Boiler/Engine Rooms |
| Paymaster Commander (S)             | 1   | Leading Stoker   | 8                                   |                |  |  |
| Paymaster Lieutenant (S)            | 2   | Stoker   | 91                                  |                |  |  |
| Paymaster Sub-Lieutenant (S)        | 1   | DC/medical team, Lower Deck  | Acting Stoker Petty Officer         | 6              |  |  |
| Acting Paymaster Sub-Lieutenant (S) | 1   | Stoker Pettv Officer   | 4                                   |                |  |  |
| Regulating Petty Officer            | 2   | 6" Shell Room  | Acting Leading Stoker               | 15             | Repair Parties, Lower/platform decks                 |  |
| Band Corporal                       | 1   |  | Chief Petty Officer Writer          | 1              |  |  |
| Bandmaster                          | 1   |  | Petty Officer Writer                | 1              |  |  |
| Bandsman                            | 10  |  | Writer                              | 3              |  |  |
| Chief Petty Officer Butcher         | 1   |  | Galley                              | Telegraphist   |  | 13   |
| Leading Cook                        | 1   |  |                                     |                |  |  |

DSTO-GD-0559

|                             |   |              |                                   |    |  |  |
|-----------------------------|---|--------------|-----------------------------------|----|--|--|
| Leading Cook (O)            | 1 |              | Chief Petty Officer Telegraphist  | 1  | across DC stations 1 per 6" turrets; 1 per 4" gun; 1 per torpedo; Lower steering, Main W/T, Aux W/T, 2ndry W/T, Telephone Room/Transmission Room |  |
| Leading Cook (S)            | 2 |              | Petty Officer Telegraphist        | 3  |  |  |
| Chief Petty Officer Cook    | 2 | Medical Post | Acting Petty Officer Telegraphist | 2  | Bridge Wings<br>Bridge Wings<br>Lower Steering Pos<br>Bridge Wings<br>4 on Bridge Wings  |  |
| Petty Officer Cook          | 2 |              | Acting Leading Telegraphist       | 1  |  |  |
| Petty Officer Cook (O)      | 1 |              | Ordinary Telegraphist             | 5  |  |  |
| Petty Officer Cook (S)      | 1 |              | Chief Yeoman Of Signals           | 1  |  |  |
| Cook                        | 4 |              | Yeoman Of Signals                 | 1  |  |  |
| Cook (O)                    | 1 |              | Acting Yeoman Of Signals          | 2  |  |  |
| Cook (S)                    | 4 |              | Leading Signalman                 | 1  |  |  |
| Assistant Cook              | 2 |              | Signalman                         | 9  |  |  |
| Canteen Assistant           | 2 |              | Acting Signalman                  | 1  |  |  |
| Canteen Manager             | 2 |              | Ordinary Signalman                | 2  |  |  |
| Warrant Officer Supply (S)  | 1 | DC team      | Wireman                           | 10 | W/T, 2ndry W/T, aux W/T Stations   |  |
| Leading Supply Assistant    | 2 |              | <b>total</b>                      |    | <b>645</b>   |  |
| Supply Assistant            | 8 |              |                                   |    |  |  |
| Supply Chief Petty Officer  | 2 |              |                                   |    |  |  |
| Supply Petty Officer        | 1 |              |                                   |    |  |  |
| Acting Supply Petty Officer | 4 |              |                                   |    |  |  |

### 3.2 DC Organisation

The aim of Damage Control (DC) is to ensure the survivability of the ship. DC crew concentrate on extinguishing fires, removing smoke, stopping and reducing flooding, and maintaining stability of the vessel. From the US Handbook of Damage Control, 1945, Chapter XXII on Damage Control Organization [132]

*The objective of damage control is the maintenance of the maximum offensive power of the ship. To achieve this purpose, effective damage control:*

1. Preserves watertight integrity.
2. Preserves buoyancy and stability.
3. Preserves manoeuvrability, mobility and seaworthiness.
4. Controls list and trim.
5. Effects rapid repairs.
6. Provides adequate protection from fire.
7. Provides protection from chemical attack.
8. Facilitates care of wounded personnel.

*Accomplishment of these aims will result in keeping the ship afloat in its best possible condition, minimizing, or even nullifying, the enemy's most destructive efforts, and thus maintaining the ship's maximum offensive power. Thus damage control is an offensive function, as well as a defensive provision.*

The Damage Control (DC) organisation on *Sydney* was coordinated from the DC Headquarters located in the Lower Steering Position, on the Platform deck. There were three Damage Control (Repair) Stations, shown in Figure 78 [49].

- DC No. 1: Lower Deck, No. 2 Mess/'A' Ammo Lobby
- DC No. 2 Lower Deck, Engineers Workshop
- DC No. 3 Lower Deck, around Ward Room and Warrant Officer Flat

DSTO-GD-0559

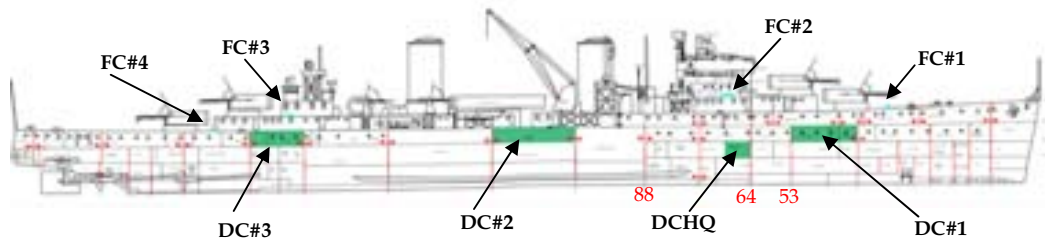

Figure 78: Profile of Sydney showing the DC Stations in green, and the WTB in red, with horizontal arrows indicating where passage is available across WTBs. The Flooding Cabinets for spray and flooding control are show in cyan. Red numbers are important WTBs.

Each team of crew members working from a DC Station are called the Repair Party, with a damage control officer in charge of each Station. The stations reported to the DCHQ, using messengers, or runners. DCHQ operated with the Executive Officer (in charge of all damage control training, equipment and operations onboard), a signalman, messenger and W/T operator.

Each DC Station was responsible primarily for a section of the ship. DC1 was responsible for all decks frame 53 forward and probably also responsible for all the internal upper deck and possibly the decks below and including the Bridge. Note that to travel aft of bulkhead 53 the crew needed to use the ladder in the No. 2 Mess (DC1) to access the upper deck first, as bulkhead 53 on the lower deck had no door. DC2 contained a concentration of engineers, mostly responsible for engines, boiler rooms and electrical systems. DC3 would have attended the Steering Gear, aft 6" guns and Magazines, and probably the Aft Control Tower equipment.

The DC Stations provided a central store area for equipment, such as shoring, leak stopping devices, pipe repair equipment, emergency electrical cables, and associated tools to deal with repairs. There was a supply of rescue breathing apparatus and spare canisters (for toxic gas resuscitation not fire fighting) and portable fire extinguishers (type not known). It was and still is common practice to disperse repair lockers around the ship with small supply of tools and equipment.

Current practice for the RAN at Action Stations is for the crew to wait at their DC Stations for impacts to occur [135]. All gear and equipment is centralised at these points, as well as the communication of type of damage by speaker/phone. It is assumed that this was also the practice for *Sydney*. At some point after initial contact the Repair Party would have begun to disperse in smaller groups, to patrol the compartments under their supervision for damage.

### 3.2.1 Repair Party Makeup

The Repair parties needed to deal with flooding, fire, smoke, casualties and damaged equipment, so were made up of crew with specialist skills. The composition would have been similar to that of the US Navy in 1945 [132]:

- Artificers from the hull department - repairs
- Electricians mates - test/locate/repair damaged circuits (power, communication, fire-control)



- Hospital corpsman – assess casualties
- Fuel-oil gang - vent lines/sounding tubes for fuel/diesel oil tanks, the sequence for emptying tanks, and how to transfer and ballasting systems
- A yeoman - shorthand/phone talker/recorder
- Storekeeper - familiar with location/contents of all storerooms
- Radioman in the topside repair party - repair/rig emergency antennas
- Other trained crew for patrols, messengers, and assistants to the artificers in handling tools and equipment
- Petty Officer in charge of each group

In particular, the DC2 Engineer's repair party would need to manage or bypass damage to the machinery spaces, operating the main propulsion plant, boilers, generators, pumps, evaporators and other engineering auxiliaries.

Small patrols of non specialists, of between 3 and 6 men, would assess and repair damage [132] where possible:

- **Fire Party** (4 - 6 men) - provided rescue breathing apparatus, tending lines, canisters, and carbon dioxide. It preceded other groups in entering damaged areas to investigate for the existence of fires, explosive and toxic gases, etc.
- **Sounding Party** (3 - 5 men) - determined the extent of flooding immediately after damage is sustained. The fuel-oil men - located contaminated fuel/diesel-oil tanks.
- **Pump detail** (2 - 3 men) - provided/rigged portable submersible pumps and discharge hoses as required.
- **Lighting detail** (2 - 3 men) - provided/rigged emergency lights or battery powered flood lamps.
- **Wreckage removal detail** (3 - 6 men) - crow bars, jacks, chain-falls, etc., cleared wreckage, especially from gun mount, director, or other movable equipment.
- **One man patrol** in each of the principal compartments.

### 3.2.2 Medical

*Sydney* had a Surgery and Sick Bay on the Forecastle deck. During Action Stations medical posts were dispersed around the ship, so that no single incident caused the loss of all medical personal and equipment, as well as being easier to treat casualties in situ.

Besides the Surgery/Sick Bay, there would have been a Forward Medical Distribution Station, an Aft Medical Distribution Station, and possibly three First Aid Posts. As stretcher and bunk space were required to treat wounded, these were likely to be within mess or cabin areas. The two Medical Distribution (MD) Stations could have been co-located with or near to the forward and aft DC Stations in the Ward Room Flat (where today's RAN still have surgical equipment), on the Lower deck. The First Aid Posts were likely to have been spread along the Platform Deck

Manning of the medical posts would possibly have required two surgical staff and a crew of three to five in each of the three main posts; and one surgical staff (or First aid attendant) with an extra one or two crew in the First Aid Posts.

DSTO-GD-0559

For treatment of toxic gas inhalation, Sydney would have had Oxygen Resuscitation Apparatus (gas masks) onboard. HMS Birmingham requested more in 1943 [48], having less than 3 Dicarbox resuscitation outfits and less than 4 refills.

### 3.2.3 Fire Fighting Capability

#### 3.2.3.1 Main Service/Firemain

Although CO<sub>2</sub> and mechanical foam extinguishment systems had been installed in engine rooms and machinery spaces during wartime [136] these were not used in *Sydney*. Sydney used salt water to flood and/or spray magazines and engine spaces. This was supplied from the Saltwater Main, or Main Service, which also supplied fire hydrants. The Main Service is also called the firemain.

The Main Service ran as a single 5" diameter pipe along the underside of the upper Deck, with connectors between each bulkhead section, in case damage to the Main required a section to be isolated. It was possible to cross connect the Main Service to the Fresh Water Service and the Main Suction in case of damage.

The Main Service was fed from the Fire and Bilge (F&B) pumps in the machinery spaces. The pumps were connected through delivery chests to a rising main and then to the Main Service. Each rising main was able to be connected, below the Lower deck, to emergency hose connections in case the Main Service was damaged. Each hose connection had a canvas hose and nozzle nearby, with hose lengths expected to have been 20ft and 40ft [48]. There were a number of corner pieces available to reduce kinking around corners or down through decks, and connectors for extending hose lengths.

The firemain could be split into sections, in case of damage. There were hydrant connections between each major bulkhead along the Lower Deck. The piping descended to the Platform deck, where hydrants were connected between each bulkhead. The piping fed the sprinkler systems in the magazines. Each hydrant had a hose and a nozzle nearby.

Fire hoses could be used to fight fires directly or to used to cool down the outside of compartments to prevent the spread of fire (known as boundary cooling).

#### 3.2.3.2 Sea Water Pumps

The fixed Sea Water Pumps on *Sydney* are listed in Table 15 [91, 137] and could be powered from emergency leads directly from dynamos.

The delivery chests of the Fire and Bilge (F&B) pumps provided the seawater to the Main Service. The F&B pumps could also connect to the Main Suction line to remove water from the bilge or main compartment. Apart from the direct connections via pipe risers as listed in Table 15 the F&B pumps could be connected via hoses to either service, to be used in emergency.

There were circulating pumps in each engine space, to cool the condensers. These could be connected into the firemain.

Portable (snorer) pumps were electrically driven, with an output of 27 tons/hour at 50psi. The snorer pumps had a lift of 20ft [48]. There was also a 70 ton/hr electric pump that could be used for fire fighting and salvage. There would also have been a 100 tons/hour submersible pump [86].

Table 15: Fixed Seawater Pumps used for Suction and Delivery on Sydney

| Pump Type    | Location                   | Direct Connection           |
|--------------|----------------------------|-----------------------------|
| Fire & Bilge | Fwd end of Fwd Engine Room | Main Service & Main Suction |
| Fire & Bilge | Aft end of Fwd Engine Room | Main Service                |
| Fire & Bilge | Fwd end of Aft Engine Room | Main Service & Main Suction |
| Fire & Bilge | Aft end of Aft Engine Room | Main Service                |
| Fire & Bilge | Fwd Boiler Room            |                             |
| Fire & Bilge | Aft Boiler Room            |                             |
| 50 ton Bilge | Fwd platform, frame 51     | Main Suction                |
| 50 ton Bilge | Aft platform, frame 177    | Main Suction                |

### 3.2.3.3 Main Suction

Main Suction could be used to pump out excess water from the ship. The 5" diameter Main Suction pipe ran the length of the ship, portside below upper deck with reduced diameter at the forward and aft extremes [138-141]. It was connected to both Bilge pumps on the Platform deck, the Boiler Room F&B pumps and one F&B pump in each engine room (see Table 15). The valves operating the Main Suction were located above the rises from the pumps, on the Lower Deck, except forward of frame 35 where they were operated from the upper Deck. The Main Suction had a lift of 24ft. It was possible to connect the Main Suction line to the Main Service in case of emergency.

### 3.2.3.4 Portable fire extinguishers and sand buckets

Portable fire fighting equipment was fitted to *Sydney*, including sand buckets and portable fire extinguishers. The location of this equipment is not generally known.

During an inspection of *Sydney* in March 1939 [142], comment was made on a two gallon Pyrine fire extinguisher in the main W/T office, and the lack of a sand bucket. It was mentioned that a Pyrine extinguisher would be used to fight an electrical fire. The Modified Leander Class specification [98] required sand buckets to be fitted to all galleys.

## 3.2.4 Flooding/Spraying Arrangements

Major compartments below the waterline were fitted with sprinklers supplied from the firemain, or fitted with seacocks for flooding the compartment directly from the sea, or both [91, 138-140]. A list of these compartments is given in Table 16. Note that many of the seacocks were also connected to bilge pumps and into the Main Suction, so that water could also be pumped out of the compartments. The flooding in engine and boiler rooms could also be controlled through the fire and bilge pumps delivery chests.

DSTO-GD-0559

These fixed systems, listed in Table 16, were primarily controlled in groups, from four flooding cabinets, located:

- Standing alone on Forecastle deck (No. 1 Flooding Cabinet, frame 27)
- Starboard of Seamen's Heads on the Forecastle deck (No. 2 Flooding Cabinet, frame 58)
- Port/Aft of Officers' Galley on the Forecastle deck (No. 3 Flooding Cabinet, frame 153) local on Lower deck
- Aft of Senior Officers' Bathrooms on the upper deck (No. 4 Flooding Cabinet, frame 173)

If the Flooding Cabinets were inaccessible or damaged, local control was possible by handwheels for each fixed system on a lower deck close to the compartment containing the system. An example of the layout of the flooding and sprinkler connection is shown in Figure 79.

Table 16: Compartments on Sydney fitted for sprinklers or flooding

| <b>Flood Only (Hold)</b>   | <b>Flood and Spray (Hold)</b>  | <b>Spray Only</b>   |
|--|--|---|
| Aviation Spirit Compartment<br>'B' Shell Room<br>Fwd Boiler Room<br>Fwd Engine Room<br>Aft Boiler Room<br>Aft Engine Room<br>Warhead Room<br>Bomb Room<br>Fireworks Magazine<br>'X' Shell Room<br>'Y' Shell Room<br>Spirit Room / Inflammables Store | 'A' Shell Room<br>6" Magazine Fwd<br>4" HA Magazine<br>6" Magazine Aft<br>2x WTC Aft<br>0.5" Magazine<br>Small Arms Magazine | Canvas Room<br>'A' Ammo Lobby<br>'B' Ammo Lobby<br>'X' Ammo Lobby<br>'Y' Ammo Lobby |

DSTO-GD-0559

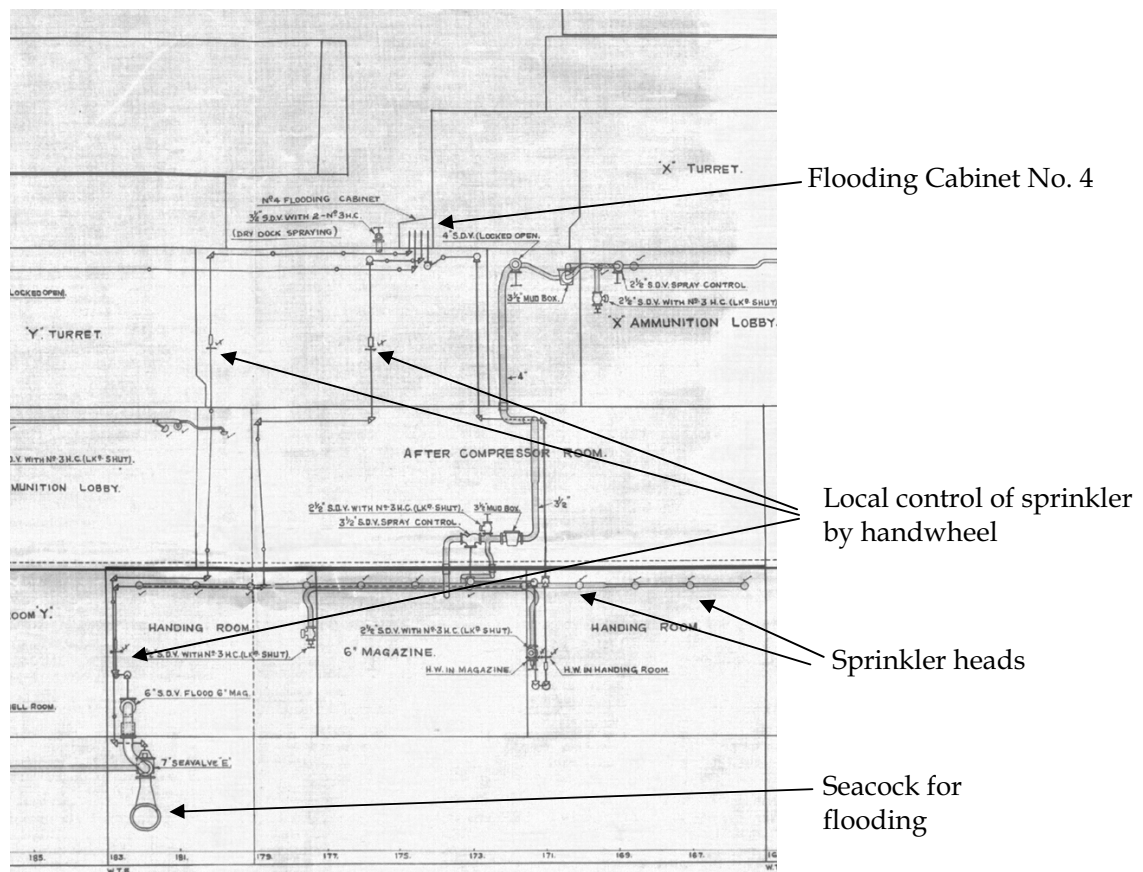

Figure 79: Example of flooding and sprinkler connections on Sydney

### 3.2.5 Furnishings and coatings

The Modified Leander Class specification [98] stated the requirements for furniture, fittings, and linings for the ship. Timber furniture was included. The specification required the use of timber to be minimised to reduce splintering and fire during action, and that timber, except that which food would come in contact with, be fireproofed. A number of other items were required to be supplied including seat cushions (filled with horse hair), linoleum, cork carpet, rugs, mats, blinds and curtains. The fire retardant properties of these materials were not specified.

The Modified Leander Class specification required the interior of the ships hull in cabins, offices and the sick bay to be fitted with light alloy sheet lining. In order to secure this lining, wooden battens were fitted.

A report from the R.A.N. Squadron Engineer Officer (S.E.O), dated 12 August 1943 [49], on the repairs to HMAS Hobart after torpedo damage also contains some notes of general interest. Included is an overview of a visit of HMS Leander to Pearl Harbour. The ship was inspected by a firefighting committee, which resulted in the supply of U.S. navy firefighting equipment to the ship, as well as the replacement of its wooden office furniture by steel furniture. A comment is also made that the S.E.O. had already documented a lack of firefighting equipment in the R.A.N.

DSTO-GD-0559

In correspondence between the Department of the Navy and a representative of a Navy contractor, between February and April 1943, it was pointed out that wooden furniture on ships was being replaced by steel furniture. This was to reduce fire risk on ships, and was required under British Admiralty instructions. It was conceded that the change would be gradual owing to facilities for its production being co-ordinated [143].

These changes would not have been made to Sydney prior to the battle in 1941.

Sydney also made extensive use of oil based paints [47].

### 3.2.6 Personal Protection

A limited number of gas masks were available for chemical weapon protection, but these were not for fighting fires. The analysis of the HMS Birmingham torpedo hit in 1943 observed that medical distribution was stopped due to the presence of toxic gas, and it was recommended that DC parties should arrange to be protected from the gas [144].

Magazine crew all wore anti-flash gear, consisting of a boiler suit, heavy gloves and head covering with the face exposed. Damage Control fire teams were outfitted as shown in Figure 80.



Figure 80: Fire Fighting outfits worn by RAN on HMAS Perth and HMAS Australia [145, 146]

### 3.2.7 Emergency Power

An understanding of the electrical systems and their operation can be gained from reports of damaged ships in WWII. Examples of the use of the electrical system in damaged ships are described in damage reports below. These examples show that there was not a standard setup, however at action stations it would be expected that the ships electrical system would be divided into four sections.

#### 3.2.7.1.1 HMS Arethusa

HMS Arethusa (cruiser, completed 1935) was hit by a torpedo below B turret in November 1942. The report of damage [44] does not describe the state of the electrical

ring main before the damage occurred, but that all power forward of the machinery spaces failed after the torpedo explosion. The switchboard room is in this area, but its state is not described. The lighting also failed in the forward most machinery space ('A' boiler room). Some electrically powered machinery failed in each of the machinery spaces, but was able to be restarted, some requiring the use of emergency leads. The electrical supply to the steering motors failed, but was restored within half an hour.

#### 3.2.7.1.2 HMAS Australia

HMAS Australia was struck by five Japanese aircraft between the 5th and 9th January 1945 [47]. For each attack, the electrical parties were described as being in the 'First degree of Readiness'. In each case the high power ring main was divided fore and aft, with four dynamos feeding the system. The low power ring main was divided fore and aft, with three motor generators feeding the system. For each attack, none of the high power system breakers opened. Some low power system breakers opened in one of the attacks, thought to be caused by shock, and the batteries took the load. However, damage to cabling and lighting occurred, requiring the use of emergency leads.

#### 3.2.7.1.3 HMS Liverpool

HMS Liverpool (Southampton class cruiser) was hit by a torpedo forward of 'A' turret in October 1940 [45]. The explosion damaged the petrol storage tank of 5700 gallons, releasing petrol and fumes, which were later ignited from an electrical fault causing an explosion and fire in the forward section of the ship. Prior to the torpedo attack, the high power ring main was divided into three sections, with a dynamo supplying each section. The two explosions damaged the electrical system in the forward section, and emergency leads were run to equipment requiring electrical supply. The forward sections of the ring main were isolated so that any problems in these sections would not affect the rest of the main. The switchboard was used to control the electrical system and find faults.

#### 3.2.7.1.4 HMS Birmingham

HMS Birmingham (Southampton class cruiser, completed 1937) was struck by a torpedo forward of A turret on 28 November 1943 [144]. Prior to the torpedo hit, the ship was in 'Electrical Organisation No. 2', and the high power ring main was connected to two dynamos, one feeding the port side, and one feeding the starboard side. After the torpedo hit, the two diesel dynamos were started and the ship moved to 'Electrical Organisation No. 1' within ten minutes, with the ring main split into four sections, a dynamo feeding each section. It was stated that the supply breakers were put into local control. Blast and flooding damage in the forward of the ship caused the loss of electrical supply to some lighting, ventilation, and two low power motor generators. Emergency lighting was available. Emergency leads were run to supply lighting, ventilation, and portable pumps. While the electrical supply to the steering system was maintained, an emergency ring main was rigged as a precaution.

After the incident, it was recommended by the ship's crew that local control of ring main breakers be available on lower deck. This would reduce the time taken moving to the location of the breakers (which on *Sydney* were a deck lower, on the Platform deck). It would also reduce the need to enter machinery spaces to control division of the ring

DSTO-GD-0559

main. British Admiralty comments indicated that a remote arrangement for the breakers was to be fitted to existing cruisers.

#### 3.2.7.1.5 HMAS Hobart

HMAS Hobart (Modified Leander class cruiser) was struck by a torpedo aft of Y turret on 20 July 1943 [147]. Prior to the incident, the ship was in 'Electrical Organisation No. 2', with the high power ring main divided into two sections, fore and aft, with a steam powered dynamo supplying each section. The breakers were in switchboard control. Emergency ring main leads were rigged and connected throughout the ship. Watchkeepers were posted to both diesel dynamo rooms, ready to start the engines if required. Automatic emergency lighting was not fitted to the ship, although emergency lanterns and torches were distributed. The explosion caused short circuits, which opened the supply breakers for both dynamos, resulting in the loss of all high power electrics. Both diesel dynamos were running within three minutes of the explosion. The engine rooms heated quickly as electrically powered ventilation stopped, and emergency leads were run from the diesel dynamos to run the ventilation systems which were operating in three minutes. The high power ring main was restored from the switchboard in four minutes, with damaged circuits isolated, including the aft section of the ship. The emergency ring main was used to provide power to the aft section. There was no failure of the low power supply.

### 3.2.8 DC equipment/procedures

#### 3.2.8.1 *Shoring/Leak Stopping*

Wood shoring, wedges, plugs, splinter boxes and cloth wadding were used on Sydney and are still used today on RAN ships. Shoring consists of lengths of wood 4"x4" (current day use Oregon, approx. 8' to fit against deck to deckhead height). They were various lengths and being wood could easily be cut to the required length.

For example, a splinter box is placed over a shell hole (ragged edges), usually with wadding around edges. This is held in place by shoring, held vertically or horizontally, or both, depending on the situation. Lengths are cut to fit the situation. Reports on other ships discuss splinter boxes, made on ship from steel [48, 49]. A watch is then kept over the repair, and over all flooding boundaries to ensure that watertight integrity is maintained. Examples are shown in Figure 81.



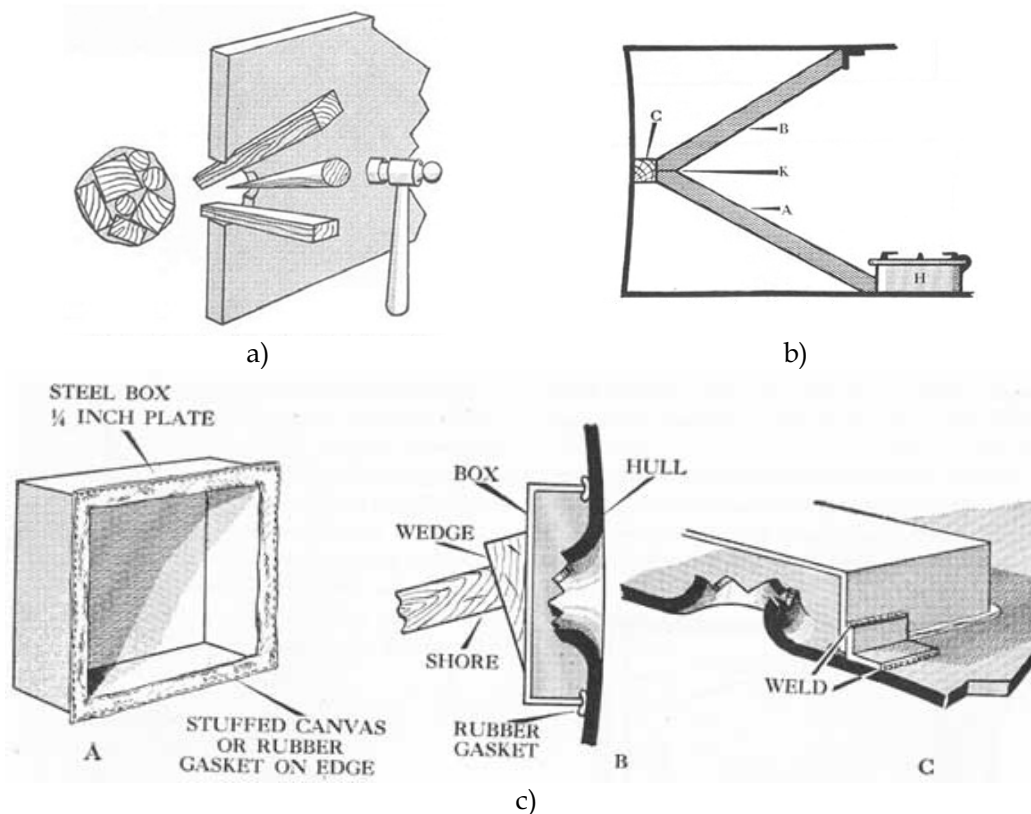

Figure 81: Examples of Damage Control repair methods for managing flooding: a) Plugging up leaks and small hole, b) shoring to brace a bulkhead, and c) use of splinter box over a larger hole.

On *Sydney*, shoring was stored in the open on the Forecastle Deck, at Station 137, between the horizontal Carley Floats, aft of the Aft Funnel (refer to Figure 32). It is assumed that more shoring was stored at other locations, probably close to Damage Control Stations.

### 3.2.8.2 Flooding Boundaries

If a bulkhead has a small hole (<300 mm) and sea water is entering a compartment, then the hole can be patched or plugged. The water can be pumped out with portable pumps and hoses, either pumping overboard through a hose or connecting to a fire and bilge pump in an engine space. Large holes causing flooding will require the compartment to be sealed, and the next bulkhead becomes a flooding boundary.

### 3.2.9 Access Routes

The only WTB with a door below the lower deck was at Frame 76, therefore crew movement around *Sydney* mainly on the Lower Deck and above. Movement up through decks was achieved via ladders, and required the hatches to be opened and closed as crew members progressed. An illustration of the routes available for movement between compartments and decks is provided in Figure 82. The vertical red lines indicate the watertight bulkheads and the red arrows indicate doorways in the watertight bulkheads.

DSTO-GD-0559

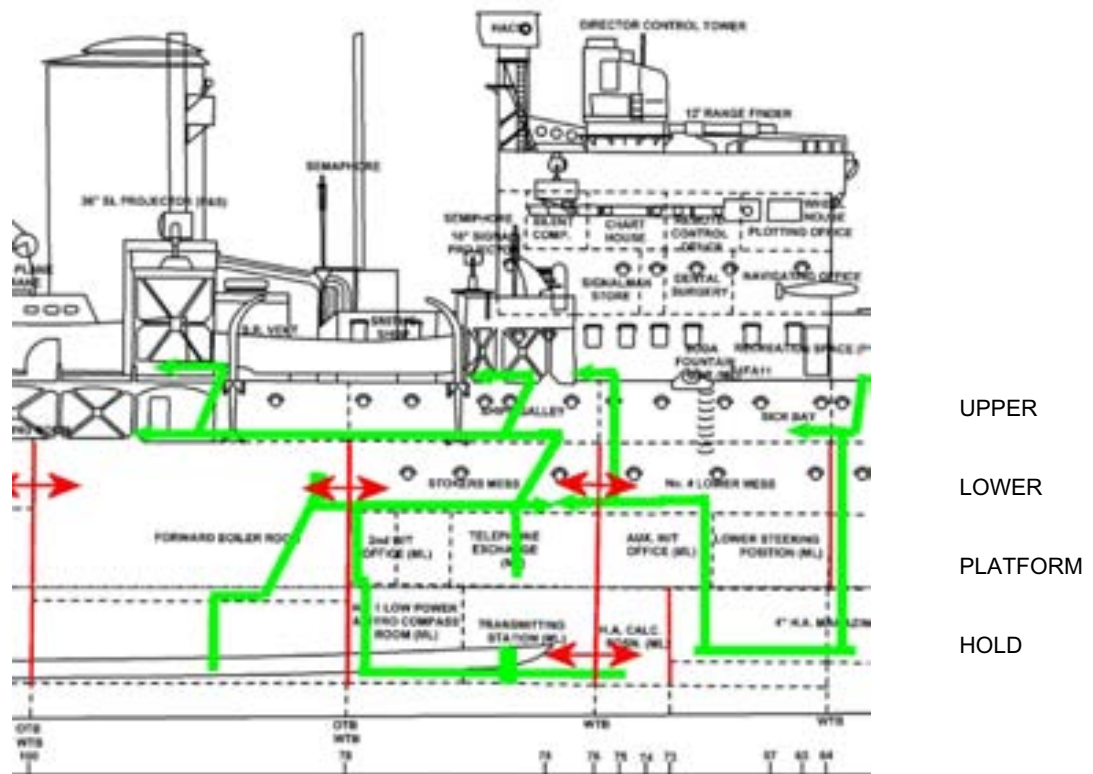

Figure 82: Examples of the routes available from ship compartments to the upper deck

### 3.2.10 Examples of damage control in damaged ships

There are several examples of British Cruisers from the same era that were hit by torpedoes or sustained other damage. Although of different classes, the WWII British cruisers all have similar layouts, including *Sydney*. All these ships successfully returned to port without sinking. However, these were single damage events, where crew could concentrate on recovering the ship's functions: repairing communications, electrical systems and engines; and responding to flooding and fire fighting.

Damage control equipment and procedures are described in reports of damage from ships during the WWII. Several examples are below:

#### 3.2.10.1 HMS *Arethusa*

HMS *Arethusa* (cruiser, completed 1935) was hit by a torpedo below B turret in November 1942 [43, 44]. Due to fire, the primary steering position could not be used, and due to flooding, the secondary steering position could not be used. Electrical power to the steering motors was lost, but restored within half an hour. However, the telephone system had been damaged, and so crew in the aft steering position could not receive orders directly, but through a 'chain of men'. The following day, the bridge was recovered, and telephone leads could be run from it to the steering position. The ships gyro compasses were damaged during the torpedo explosion and a magnetic boat compass was used for steering. Damage control included the shoring of 61 bulkheads and hatches.

### 3.2.10.2 *HMS Liverpool*

HMS Liverpool (a Southampton class cruiser) was hit by a torpedo forward of 'A' turret in October 1940 [45]. Approximately 35 minutes after the torpedo hit, petrol fumes from a damaged petrol storage tank were ignited by an electrical short, causing an explosion and further structural damage. The intact bulkhead aft of the damage was shored to maintain its structural integrity.

### 3.2.10.3 *HMAS Australia*

HMAS Australia was struck by five Japanese aircraft between the 5<sup>th</sup> and 9<sup>th</sup> January 1945 [47]. The report of the incident indicates three damage control teams, labelled DC1, DC2 and DC3. DCHQ (Damage Control Head Quarters) was also noted. In one incident, the aircraft struck the ship near the waterline, and the hull was breached causing flooding. Two damaged and leaking bulkheads were shored. Two 'snorer' pumps were used to remove floodwater from compartments. Liquid within the ship was pumped around so that the trim was changed and the ship listed to 10° starboard, so that the water pressure on a damaged bulkhead was reduced. It was commented that this list caused difficulties moving about and a greater list would render the ship unworkable.

### 3.2.10.4 *HMS Birmingham*

HMS Birmingham (a Southampton class cruiser, completed 1937) was struck by a torpedo forward of A turret on 28 November 1943 [48]. The incident killed 27 crew, 45 were injured, and 45 were rendered unconscious from toxic gases produced from the detonation of the torpedo explosive. Some telephone circuits were damaged due to flooding. Reports from two crew allocated an information gathering role assisted the damage control officer in understanding the situation. A flooding boundary was set at a watertight bulkhead, and pumping and shoring occurred forward of this boundary. Pumping was initially undertaken with a 70 ton (per hour) 'Snorer' pump, and a 70 ton (per hour) diesel pump. Shoring activities included the holding down of leaking hatch covers, and the holding in place of a pad of clothing to seal a split in a bulkhead. The main suction line was also used to remove water from the ship, with the use of a fire and bilge pump.

The ship was loaned petrol powered pumps by a tug during damage control efforts, and these were considered superior to the electric powered 'Snorer' pumps held on the ship.

### 3.2.10.5 *HMAS Hobart*

HMAS Hobart (a modified Leander class cruiser) was struck by a torpedo aft of Y turret on 20 July 1943 [147]. Prior to the incident, the damage control organisation was in 'cruising state'. This consisted of DCHQ located in the Lower Steering Position, manned by the damage control officer and a telephone operator. Three damage control sections were spread across the ship, each with three or four crew, including a telephone operator, a torpedo man, and a scout. After the explosion, it took 5 to 10 minutes for the damage to be surveyed and full reports to be provided. Communications via sound powered telephones and electrically powered telephones were effective. While some senior crew in the damage control organisation were killed, including the executive

DSTO-GD-0559

officer, senior damage control officer, and a damage control officer, the damage control efforts were effective. Flooding boundaries were established early, and these were able to be extended towards the damage as damage control was undertaken. Shoring of flooding boundaries was undertaken, and a splinter box (of welded steel) was shored in place over a leaking scuttle reducing the ingress of water. Leakage of water and oil into the aft machinery space through damaged propeller shaft glands was controlled with a fire and bilge pump in the space. The ship had two portable 50 ton (per hour) electric 'Snorer' pumps, and three portable 70 ton (per hour) electric pumps. One of the 'Snorer' pumps was used to control flooding in the damaged section.

## 4. HSK Kormoran

### 4.1 Hull design

*Kormoran* (Ship 41), Figure 83, began life as a cargo liner built for the Hamburg-Amerika Line, known as Hapag for short, and had been launched under the name of *Steiermark* from the Deutsche Werft at Kiel. *Kormoran* was a new type of passenger ship intended for the East Asia run. *Kormoran* had completed ship trials before the war, the outbreak of which had prevented her being taken into service.

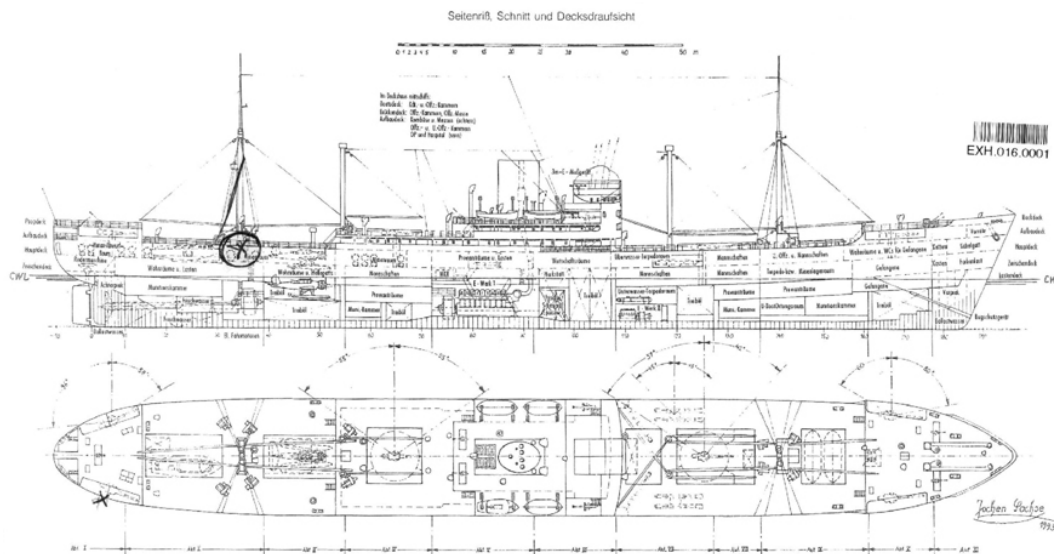

Figure 83: General Arrangement of *Kormoran* [148]

The principal particulars of *Kormoran* were:

|                     |  |
|---------------------|--|
| Displacement:       | 19,900 tons  |
| Dimensions:         | 167.5 m LOA, 157.0 m LWL x 20.2 m beam x 8.5 m draught   |
| Machinery:          | Four Krupp-Germania 9-cylinder four-stroke diesel engines delivering 3,600 BHP.<br>Two propulsion electric motors rated at 6,370 SHP each.<br>Total SHP 12,740 for 17.5 knots (full load, clean hull). |
| Bunkers and Radius: | Diesel fuel 5,200 tons; range 84,500 miles at 10 knots; 74,000 miles at 13 knots; 50,000 miles at 17 knots   |
| Protection          | Splinter protection for chart-house, the helm and engine-room telegraph posts.   |

DSTO-GD-0559

|             |   |
|-------------|---|
| Armament:   | Six 15 cm guns in single mounts, two 3.7 cm A.A. in single mounts, five 2-cm cannon in single mounts, several 7.92 mm machine guns; six 21" torpedo tubes in two twin-tube above-water mounts and two submerged tubes.; two aircraft and one light fast motor boat. |
| Complement: | 400   |

#### 4.1.1 Machinery

##### 4.1.1.1 Propulsion

*Kormoran* was fitted with diesel-electric propulsion. The power necessary for propelling the ship and providing all the various ship auxiliaries such as pumps and winches, the lighting, heating and so on was produced by four diesel generators. Two electric motors drove the twin screws.

*Kormoran's* four main diesel engines were Krupp-Germania 9-cylinder four-stroke diesel engines delivering 3,600 BHP each at 240 rounds per minute. The two propulsion electric motors were rated at 6,370 SHP each. The ship had a maximum speed of 17.5 knots in the full loaded condition with a clean hull.

##### 4.1.1.2 Electrical Power

As built, the *Steiermark's* four diesel-electric engines also provided all the electrical power for the main shipboard services, such as pumps, hoists, lights and heaters. The amount of power thus available was not sufficient for an auxiliary cruiser, so an auxiliary generator room was set up in Hold 3. Two small 6-cylinder diesel generators were installed.

##### 4.1.1.3 Fresh Water Production

*Kormoran* had two small boilers that were used exclusively for producing drinking water.

#### 4.1.2 Bunkers

*Kormoran* carried approximately 5,200 tons of diesel fuel giving the following likely endurance figures:

- 84,500 miles at 10 knots.
- 74,000 miles at 13 knots.
- 50,000 miles at 17 knots.

#### 4.1.3 Ships boats

In addition to the four ship's boats, which were carried on the bridge superstructure, two large steel lifeboats were stowed in No.1 hold. The extra boats were carried to help accommodate the raider's 400 crew. These lifeboats were supplemented by a boat taken

from one of *Kormoran's* victims, plus a boat from the supply ship *Kulmeland*. A number of large inflatable rubber dinghies were carried for transferring supplies and torpedoes to U-boats.

#### 4.1.4 Wireless telegraphy and visual signalling

No information has been located on *Kormoran's* W/T, direction finding or transmission jamming ability.

#### 4.1.5 Protection

Detmers [149] writes that there was splinter protection for chart-house, the helm and engine-room telegraph posts. No evidence has been located to confirm this.

## 4.2 Weapons Systems

### 4.2.1 Main Armament and Fire Control

*Kormoran's* main armament consisted of six 15 cm guns. The Nos. 1 and 2 guns were fitted under the Forecastle — No. 1 on the starboard side and No. 2 on the port side. The Nos. 3 and 4 guns were in Holds 2 and 4 respectively. The Nos. 5 and 6 guns were fitted under the quarterdeck — No. 5 on the starboard side and No. 6 on the port side. With this arrangement *Kormoran* was limited to a full broadside of four guns rather than six. The location and firing arcs of the six 15 cm guns are shown in Figure 83 and Figure 84.

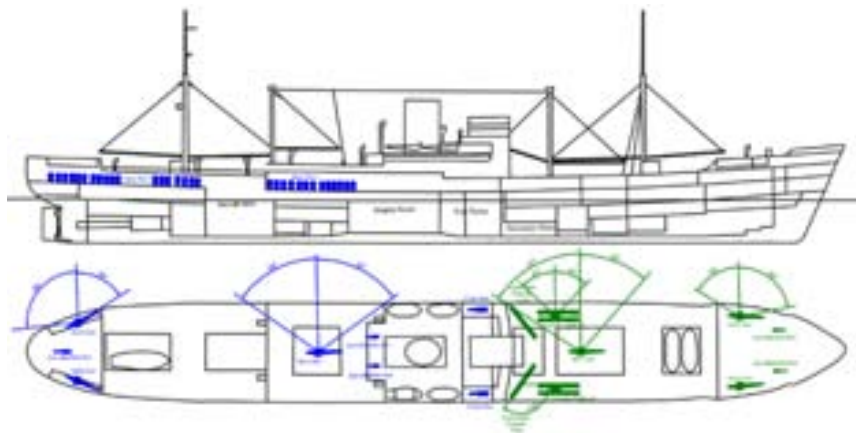

Figure 84: Weapons identified within the wreckage are marked as green and match those presented in reference material [148].

DSTO-GD-0559

The 15 cm guns were most likely 15 cm/45 SK L/45s. The principal characteristics of these guns are shown below:

|                    |   |
|--------------------|---|
| Designation        | 15 cm/45 SK L/45  |
| Ship Class Used On | Most German capital ships of World War I<br>Many cruisers were rearmed with this gun between 1915-1918, as well as <i>Emden</i> (1925) and the Merchant Raiders of WWII |
| Date of Design     | 1906  |
| Date In Service    | 1908  |
| Gun Weight         | 5,730 kg  |
| Gun Length OA      | 6.710 m   |
| Rate of Fire       | 5 - 7 rounds per minute   |

It has been stated that German capital ships were provided with an ammunition hoist for each 15 cm gun and that these could provide 7 or more complete rounds per minute [150]. For light cruisers the rate of supply was about three to five rounds per minute per gun once the ready ammunition had been used up.

The range during WWII for the 15 cm gun with a 45.3 kg explosive is reported as:

|                             |                       |
|-----------------------------|-----------------------|
| Elevation                   | With 45.3 kg HE Shell |
| Range at 30° (WWII Raiders) | 19,400 m              |

During WWII, Merchant Raiders armed with these guns were apparently supplied with the more streamlined shells as used for the 15 cm/55 SK C/28.

The mounting data for the 15 cm guns are as follows:

|                      |   |
|----------------------|---|
| Designation          | MPL C/16 Modified                       |
| Weight               | 17,116 kg                               |
| Elevation (see Note) | -10°/+27°<br>In WWII Raiders: -10°/+30° |
| Elevation Rate       | Manual operation, only                  |
| Train                | about +150°/-150°                       |
| Train Rate           | Manual operation only                   |
| Gun recoil           | 45.0 cm                                 |

The elevation shown above is "as designed". Late in the World War I, some light cruisers may have been modified to increase elevation to +30° and these are the mountings that appear to have been used on the Merchant Raiders of WWII, Figure 85.



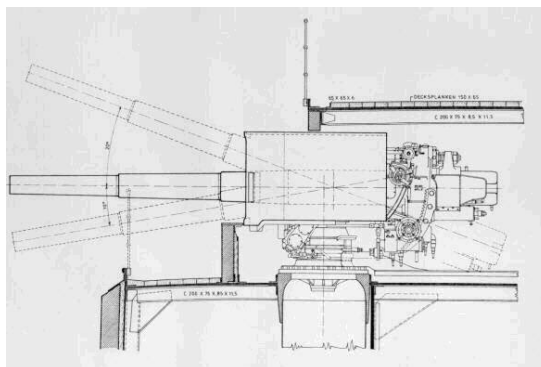

Figure 85: Sketch of one of the 15 cm/45 SK L/45 casemate guns on the KM Baden

Detmers [149] writes: “Even No. 3 gun, which according to its log had been removed from the battle-cruiser *Seydlitz* after the Battle of Jutland, and had knocked around disregarded in the yards for years until it was put into service again and given to us, stood up to every requirement and took part in every action just as well as a new gun could have done.”

#### 4.2.1.1 Fire Control

The only fire control systems fitted to *Kormoran* were a 3 m range finder for surface actions, a 0.75 m anti-aircraft range finder, which could also be used for surface targets, and telephone communications between the Gunnery Officer on the bridge and all gun positions. Directional and height indicators and other more modern equipment were not available.

*Kormoran* did not have:

- A fire control table to solve the fire control problem and automatically send the 15 cm guns the correct elevation and training.
- Cross levelling gear to compensate for the rolling of the ship.
- Any system to allow the firing of salvos.

#### 4.2.2 Anti-Aircraft and sub-calibre armament

*Kormoran's* anti-aircraft armament consisted of two 3.7 cm anti-aircraft guns and five 2 cm guns. *Kormoran* also carried a number of light machine guns (possibly five).

##### 4.2.2.1 3.7 cm Anti-aircraft Guns

Two 3.7 cm army anti-aircraft guns, Figure 86, were installed on port and starboard sides by the bridge. These guns were most likely German army 3.7 cm Flak 18 guns. The locations of the two 3.7 cm. army anti-aircraft guns are shown in Figure 83 and Figure 84.

These guns had a rate of fire of 80 rounds per minute, a maximum horizontal range of 7,100 m and could fire a high-explosive projectile of 0.7 kg or an armour piercing (AP) projectile of 0.7 kg [151].

DSTO-GD-0559



Figure 86: 3.7cm AA gun (Flak 18 and 36) [151]

#### 4.2.2.1.1 Claims that the 3.7-centimetre guns were anti-tank guns

Some authors [152-154] have claimed that the two 3.7 centimetre guns fitted to *Kormoran* were anti-tank guns.

From a technical viewpoint the 3.7 cm PAK antitank gun would have been a most unsuitable weapon to install on an auxiliary cruiser such as *Kormoran*. The effective range of the 3.7 cm PAK antitank gun was only 600 yards and its rate of fire only 8 to 10 rounds per minute.

#### 4.2.3 2 cm Cannon

Five 2 cm cannon were fitted, two forward on the Forecastle, two amidships (at the aft end of the superstructure), and one aft on the quarterdeck. These guns were most likely German Navy 2 cm FLAK C30 cannon. The locations of the five 2 cm cannons are shown in Figure 83 and Figure 84.

The 2 cm FLAK C30 Cannon fired a 120 g shell with an effective rate of fire of 100 to 120 rounds per minute and had a maximum horizontal range of 4,400 m. Ammunition was loaded in a 20 round box magazine.

There was a large range of possible ammunition for this cannon — *Kormoran* carried 10,000 rounds of 2 cm ammunition.

#### 4.2.4 Light Machine Guns

Detmers [149] writes “We also had five heavy machine-guns.” These weapons were most likely 7.92 mm MG-34 light machine guns.

#### 4.2.5 Other

There have been claims that *Kormoran* was fitted with (or intended to be fitted with) a single 6 cm or 7.5 cm gun for firing warning shots. There is no evidence to support these claims.

#### 4.2.6 Torpedoes

*Kormoran* was equipped with six torpedo tubes. Two sets of twin tubes were mounted port and starboard above the waterline and forward of the bridge structure. The other two torpedo tubes were mounted below the waterline in the No. 3 hold immediately forward of the bridge. The location and firing arcs of the six torpedo tubes are shown in Figure 83 and Figure 84.

##### 4.2.6.1 Deck-mounted Torpedo Tubes

*Kormoran* was fitted with a deck-mounted torpedo battery to port and starboard below the bridge, each with a double tube. The tubes could be trained outboard, for which purpose a cogwheel mechanism was fitted with ratchets, and the men had to manhandle the tubes into the correct notch and then pull the ratchet forward.

Detmers [149] writes: "...our torpedo tubes had been taken from old torpedo boats which had seen action in the Battle of Jutland; before we got them they had been out of commission for years." Detmers was almost certainly wrong about the origin of these tubes.

Early WWI German torpedo boats and destroyers had 17.7" torpedo tubes. Later WWI German torpedo boats and destroyers had 19.7" torpedo tubes. There were two German destroyers completed in 1918 that had 23.6" torpedo tubes, but there were no WWI German torpedo boats or destroyers that had 21" torpedo tubes.

At the end of WWI Germany had to surrender all its most modern torpedo boats and destroyers and was only allowed to keep a small number of older ships. Most of these had served at Jutland (which was probably the source of Detmers' comment). It is highly likely that some of these ships were upgraded after WWI and received new twin 21" torpedo tubes or at the very least new tubes on the old mountings – and a pair of these tubes may have ended up on *Kormoran*.

##### 4.2.6.2 Underwater Torpedo Tubes

*Kormoran* was fitted with a fixed underwater tube to port and starboard, mounted at an angle of 35° abaft the beam. These tubes were not fitted with modern extension sleeves, with the result that the vessel's speed immediately affected the torpedo as soon as it left the tube, and there was a danger that it might be forced off course. Further, they could be used at a ship speed of not more than three knots.

##### 4.2.6.3 Torpedoes

*Kormoran* carried fifteen torpedoes. These torpedoes were most likely 53.3 cm G7a T1s. It is unlikely that the torpedoes were the more modern 53.3 cm G7e T2 or T3. These electric

DSTO-GD-0559

torpedoes were reserved for U-Boats and Schnellbootes (E-boats) and, in any case, would have been unsuitable for use on board an auxiliary cruiser as:

- it was necessary to remove the torpedo from the tube every three or four days for servicing (with, amongst other things, the battery charge dropping over time); and
- the batteries needed to be preheated to 30° Celsius before firing.

The 53.3 cm G7a T1 torpedoes entered service about 1938 and had a 300 kg Hexanite explosive charge. The range was 6,000 m at 44 knots, 8,000 m at 40 knots and 14,000 m at 30 knots.

It is unlikely that *Kormoran* had any fire control system for the torpedoes (such as fitted on *Sydney's* bridge). It is probable that the Torpedo Officer had a simple sight on the bridge and telephone communication with the tubes. Detmers [149] writes "Aiming was done by turning the ship towards the target, and when the target came into the viewfinder the torpedo officer would order the torpedo to be fired."

#### 4.2.6.4 Mines

*Kormoran* carried 360 (EMC) moored type contact mines and 30 (TMB) magnetic ground mines. The former could be deployed in coastal waters up to the 200 fathom line, but the latter, which rested on the seabed, could only be laid in water with a maximum depth of 10 fathoms.

#### 4.2.6.5 Minelaying Motor Boat

To enable the magnetic mines to be safely deployed, a light motor boat was carried and stowed in No.6 hold. The Leichte Schnellboote (LS) series boats were originally designed as small torpedo boats, but technical problems with the 45-centimetre torpedoes they were to carry meant that the first two boats, LS2 and LS3, were completed as minelayers. *Kormoran* received LS3, which was capable of carrying four magnetic mines.

The LS3 had a length of 12.5 m, was propelled by diesel engines for a maximum speed of up to 40 knots and a range of 300 nautical miles at 30 knots.

### 4.3 Aircraft Arrangements

For reconnaissance purposes, two Arado 196 floatplanes were carried. No catapult for launching the aircraft was fitted.

### 4.4 Searchlights

*Kormoran* carried had a searchlight which could be raised on the mast.

### 4.5 Smoke generation

*Kormoran* was fitted with apparatus for smoke-screen lying concealed in the quarterdeck.

## 4.6 Nature of camouflaging of armament and fire control

A key element in the engagement between *Sydney* and *Kormoran* was the time taken to de-camouflage *Kormoran* and fire upon *Sydney*. This section aims to describe the mechanisms used and to provide estimates of these times.

### 4.6.1 Main Armament

#### 4.6.1.1 No.1 and No.2 Gun

The two 15 cm guns mounted beneath the Forecastle were concealed behind hinged, counterweighted steel plates that opened upwards. Figure 87 and Figure 88 show the probable design of the camouflage mechanism based on the description of *Kormoran* crew members [74], the underwater photographs of *Kormoran* and photographs of other German auxiliary cruisers.

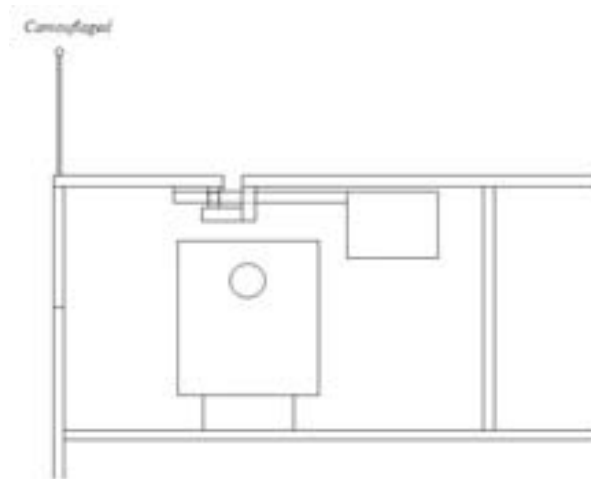

Figure 87: No 1 gun in the camouflaged condition

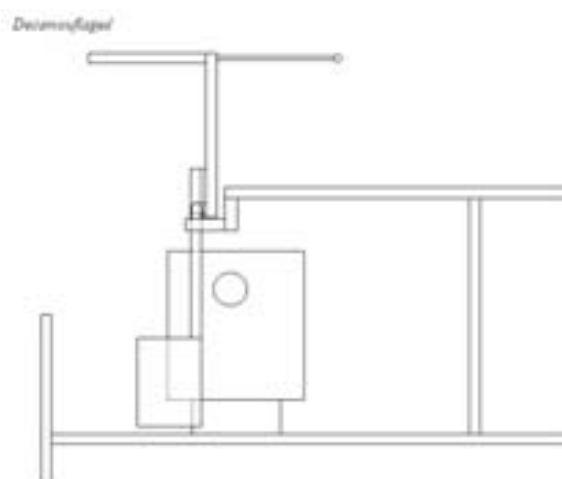

Figure 88: No 1 gun in the uncamouflaged condition

Figure 89 is a photograph of the same camouflage system on board HSK *Michel*.

DSTO-GD-0559

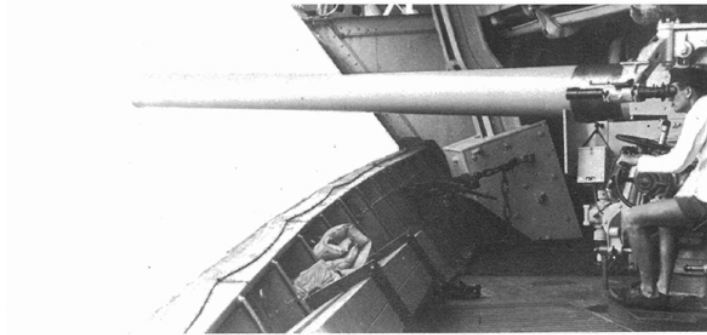

Figure 89: HSK Michel – Counter Weighted Camouflage Mechanism [155]

#### 4.6.1.2 No. 3 and No. 4 Gun

The two 15 cm guns were mounted on the centreline of the ship in Nos. 2 and 4 cargo holds, and were concealed behind collapsible hatch coamings. It can be seen from both Figure 83 and underwater photographic evidence [156-158] that these guns were fitted inside pits or tubs that were lower than the surrounding deck. This was done to ensure that the guns did not protrude above the standard height hatch coamings. It did, however, restrict how far the guns could be depressed.

Figure 90 is a photograph of *Kormoran's* swimming pool concealed inside a hatch (most probably the hatch over Hold No. 6 which also contained the Leichte Schnellboote (LS3). It can be seen that a light canvas tarpaulin was used to cover the hatch and conceal the Leichte Schnellboote and swimming pool underneath. It can be reasonably assumed that a similar a light canvas tarpaulin was used to cover the hatches over Nos. 2 and 4 cargoholds and conceal the 15 cm guns inside.

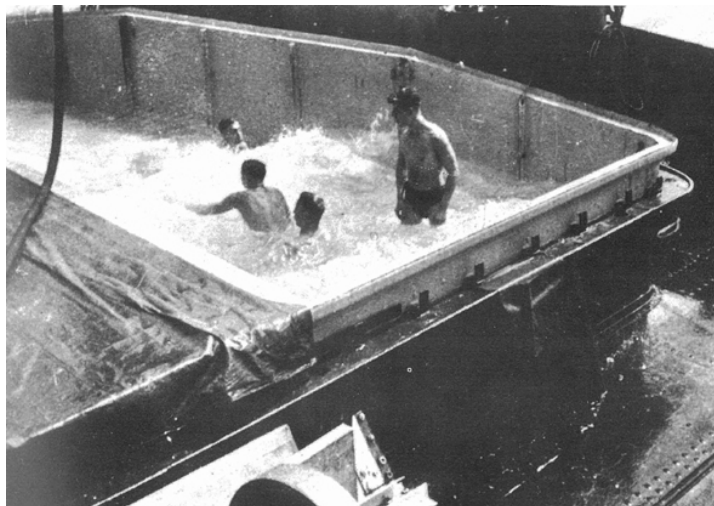

Figure 90: *Kormoran* – Swimming Pool [155]

Figure 91 shows the probable design of the camouflage system based on the description of *Kormoran* crew members [74], the underwater photographs of *Kormoran*, photographs of *Kormoran* and photographs of other German auxiliary cruisers.

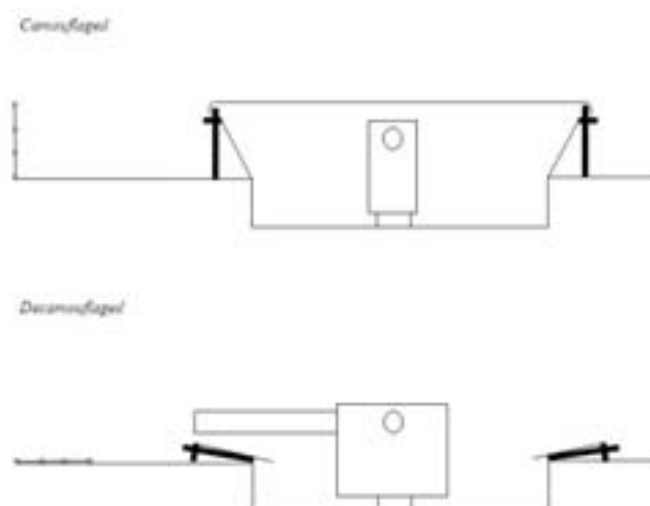

Figure 91: No 3 gun camouflage system

It has been claimed that the two 15-cm guns mounted on the centreline of the ship in Nos. 2 and 4 cargo holds were mounted on hydraulic platforms that were raised into position as required. No evidence has been found to show that any German auxiliary cruiser had 15 cm guns mounted on hydraulic platforms. The underwater photographic evidence [156-158] clearly shows that the No. 3 gun in Hold No. 2 was not mounted on a hydraulic platform. It is highly probable that the No. 5 gun in Hold No. 4 was identically mounted to the No. 3 gun.

#### 4.6.1.3 No.5 and No.6 Gun

The two 15 cm guns mounted at the stern beneath the poop deck were concealed behind hinged, counterweighted steel plates that opened upwards in the same manner as for the No. 1 and No. 2 guns.

#### 4.6.1.4 Fire Control

The 3 m surface rangefinder could be hydraulically raised to a point over the bridge and the 0.75 m anti-aircraft rangefinder could be hydraulically raised on the poop.

### 4.6.2 Anti-Aircraft Armament

#### 4.6.2.1 3.7 cm Anti-aircraft Guns

The 3.7 cm anti-aircraft guns were concealed behind sheet metal screens, outboard and slightly aft, and below, the bridge.

#### 4.6.2.2 2 cm Cannon

The five 2 cm cannon were concealed below the deck and raised hydraulically.

DSTO-GD-0559

### 4.6.3 Torpedoes

#### 4.6.3.1 Deck-mounted Torpedo Tubes

The tubes were concealed behind steel plates and had to be pushed into the firing position after the covering plates had been raised. Figure 92 and Figure 93 show the probable design of the camouflage mechanism based on the description of *Kormoran* crew members [74], the underwater photographs of *Kormoran* and photographs of other German auxiliary cruisers.

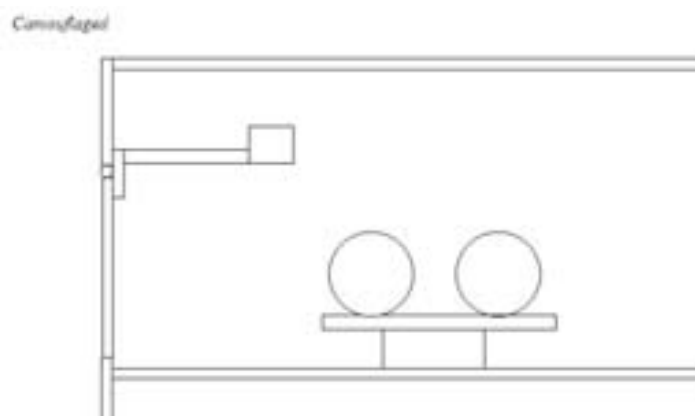

Figure 92: The torpedo tubes camouflaged

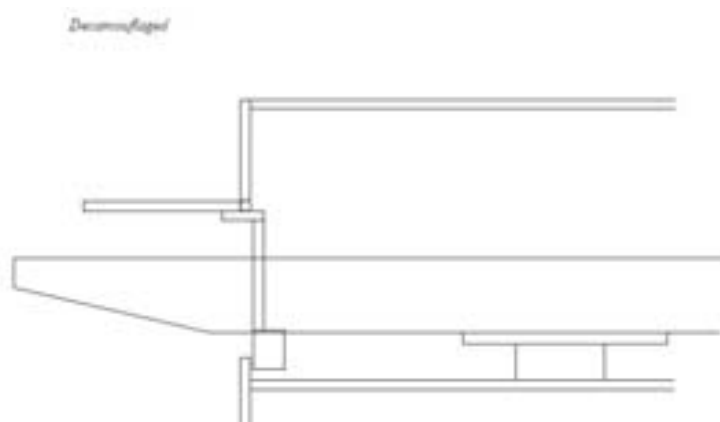

Figure 93: The torpedo tubes uncamouflaged

Figure 94 is a photograph of HSK *Widder* firing a torpedo from under a similar camouflage system to *Kormoran*.



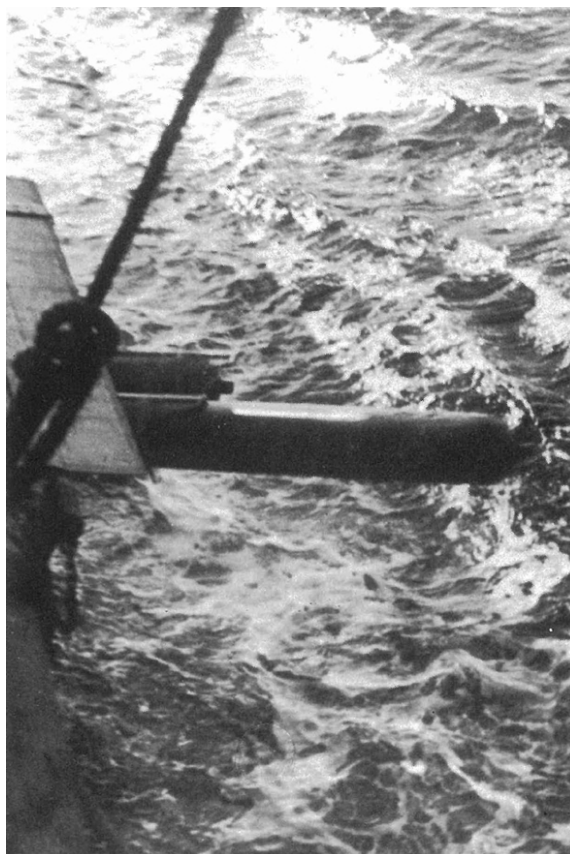

Figure 94: HSK Widder firing a torpedo [155]

#### 4.6.4 Mines

The mines were stowed on the mine deck – a specially constructed deck which ran aft from No. 4 hold to the quarterdeck. The mine deck, situated one deck below the upper deck, ran for almost a third of the ship's length. The mines were laid through two concealed doors in the stern. The mine deck and concealed stern doors are shown in Figure 83.

##### 4.6.4.1 Minelaying Motor Boat

Leichte Schnellboote was concealed inside hold No. 6. The boat was transferred from the hold to the sea by derrick, and returned by the same means. The location of the Leichte Schnellboote is shown in Figure 83.

Figure 95 shows the similar Leichte Schnellboote LS2 being lowered into the water by HSK *Komet*.

DSTO-GD-0559

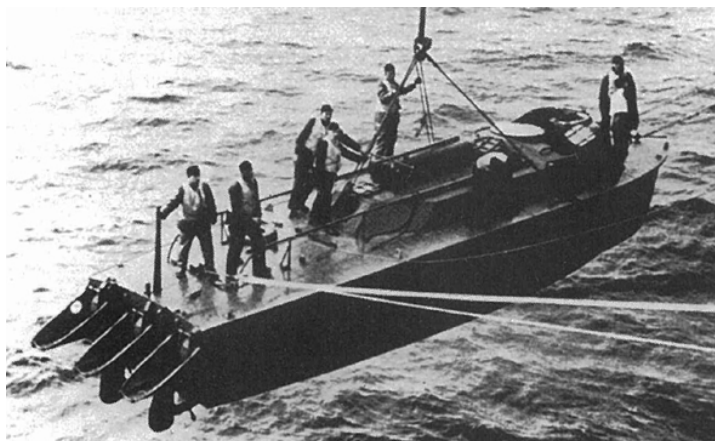

Figure 95: *Leichte Schnellboote LS2 being lowered into the water by HSK Komet*

#### 4.6.5 Aircraft arrangements

The two Arado 196 floatplanes were concealed in No. 5 hold. The aircraft were transferred from the hold to the sea by derrick, and returned by the same means. Figure 96 shows an Arado AR196A-1 stowed in the hold and being lowered into the water by HSK Orion.

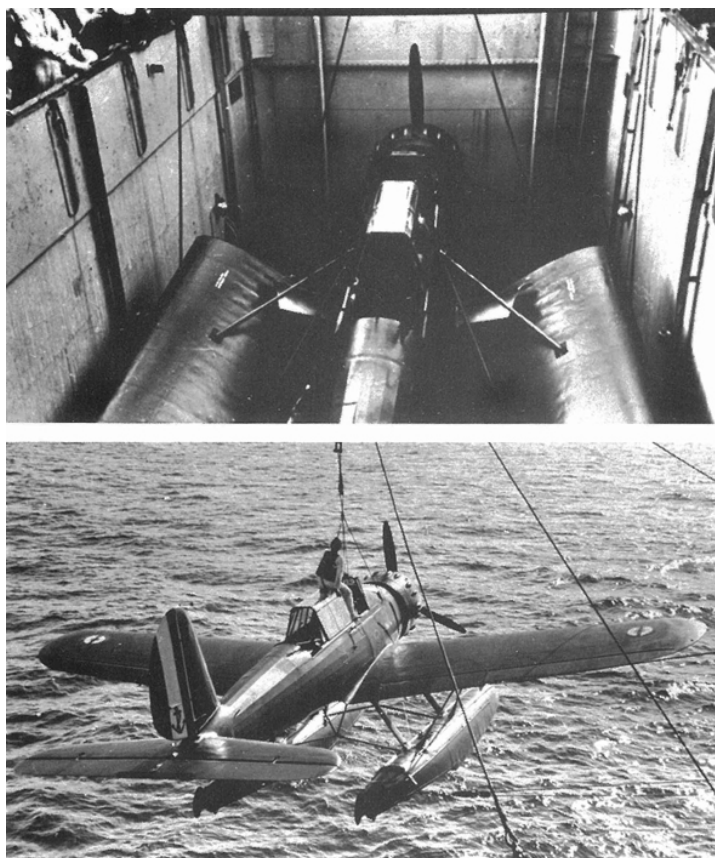

Figure 96: *An Arado AR196A-1 aboard HSK Orion*

## 4.7 Time to de-camouflage and open fire

An estimate of the time taken to de-camouflage and open fire for the various weapons systems on *Kormoran* is provided. The analysis is based upon the technical descriptions of the de-camouflaging equipment together with some assumptions made on the operational aspects.

### 4.7.1 Operational Assumptions

In providing an estimate of the time taken to de-camouflage *Kormoran* and fire the weapons some assumptions had to be made regarding the level of crew readiness. Therefore it has been assumed that all weapons systems were pre-loaded before the order to de-camouflage and open fire was given. Furthermore the crew would have been manning the weapons in their correct positions ready for the encounter. It is also assumed the bearing and range of *Sydney* was known before the order to engage was given, with the guns set to the correct elevation to engage the target. This is considered viable due to the short range between *Sydney* and *Kormoran*.

It is also assumed that the crew of *Kormoran* were highly trained so that the time taken for Detmers to pass the order to de-camouflage was approximately one second, to pass the order for firing was one second and the time taken to squeeze the firing trigger was one second. In total this allows a period of three seconds for the command structure.

### 4.7.2 15 cm Guns

As previously mentioned *Kormoran* carried six 15 cm guns. These are located under the Forecastle deck (Nos. 1 and 2 Guns), within hold No.2 (No. 3 Gun), within hold No. 4 (No. 4 Gun) and finally underneath the quarterdeck (Nos. 5 and 6 Guns), Figure 84. Each of these guns would have been stowed in different orientations prior to de-camouflaging and therefore need to be considered independently. Only those guns that can bear on the starboard side have been considered.

#### 4.7.2.1 Forward Starboard No. 1 Gun

The key feature of the camouflage equipment for the forward guns was the large counter-balanced weights. These enabled the guns to be to be exposed within two seconds.

The gun itself would have been stowed pointing in the forward direction. The critical time step is the duration for the crew to train the gun from the forward bearing to the bearing of the target. For this type of gun the training is done manually. An estimate for the training rate is difficult to obtain, however for a more modern 15 cm gun [69] rates of 8°/second have been quoted. For the current analysis a best estimate of 7.5°/second was used, with a conservative estimate of 6°/second. It was also assumed that there was sufficient room to begin training the gun at the same time the de-camouflaging process began, therefore the two seconds to de-camouflage was not considered. The estimate of the time taken from the order to de-camouflage and fire was between 15 and 18 seconds for the forward 15 cm gun.

DSTO-GD-0559

#### 4.7.2.2 Centreline guns within the cargo holds (No. 3 and 4)

The major difference between the de-camouflaging equipment for these guns is that the canvas tarpaulin over the hatch covers needs to be removed and the collapsible hatch coamings need to be dropped. This was estimated to have taken five and two seconds respectively. The guardrails also need to be dropped. However it was not essential as the guns could be fired with these in situ.

There was sufficient room within the cargo holds for the guns to be trained to 45° to starboard prior to the de-camouflage command. Therefore these guns will only have to train 45° to bear upon the target abeam. Using the same rates for training this equated to 6 seconds for the best rate and 8 seconds for the conservative rate. In total it was therefore estimated that the time taken to de-camouflage and fire the guns within the holds was between 16 and 18 seconds.

#### 4.7.2.3 Aft starboard gun No. 5 gun

The major difference between the aft starboard gun and the forward starboard gun is the gun's orientation prior to the de-camouflage order. In this case the gun would have a 65 degree bearing when stowed and would only need to be trained 25° to bear on a target abeam. Therefore the total time from the order to de-camouflage and open fire would be shortened to 12 to 14 seconds depending upon the training rate used.

#### 4.7.3 3.7 cm anti-aircraft guns

The time taken for these guns to de-camouflage and fire on a target beam on would be very small – a few seconds.

#### 4.7.4 Deck Mounted Torpedoes

As with the guns it is assumed that the torpedoes were loaded and set with the depth and speed settings prior to the order being given and that the bearing was known.

The time taken to raise the camouflage concealment flap was estimated to be about two seconds. It was assumed that the training of the torpedo tubes was completed with manual labour. As the torpedo tubes were trained forward prior to the de-camouflage order they would have needed to be trained 90° which was likely to take 30 seconds. Therefore the total time required to fire a torpedo was 32 seconds. This time would be larger if *Kormoran* was required to alter course to bring on a more favourable bearing. A change of about 10° may have taken about 10 seconds.

#### 4.7.5 Fixed Underwater Torpedoes

All activities relating to the firing of a fixed underwater torpedo could be carried out prior to the de-camouflage order. Therefore these could be fired instantly, assuming *Kormoran's* speed was low enough and the target was on the correct bearing.

#### 4.7.6 Conclusions

The key factor determining the time to de-camouflage and open fire was the time taken to train the guns or torpedoes onto the target. This time cannot be practically reduced. The best possible elapsed time taken and a conservative time taken to de-camouflage and open fire is shown in Table 17.

*Table 17: Time taken to open fire from order to de-camouflage and engage*

| <b>Weapon</b>                         | <b>Best Time (Seconds)</b> | <b>Conservative Time (Seconds)</b>   |
|---------------------------------------|----------------------------|--|
| Forward starboard (No. 1) 15 cm. gun  | 15                         | 18   |
| Forward centreline (No. 3) 15 cm. gun | 16                         | 18   |
| Aft starboard (No. 5) 15 cm. gun      | 12                         | 14   |
| Deck Mounted Torpedo                  | 32                         | +1 second for each degree of course change, assuming that the ship is out of range |

## 5. Evidence from the wreck site

### 5.1 HSK Kormoran Wreck Site

#### 5.1.1 Debris Field

The *Kormoran* wreck site consists of two main features; the first feature consists of a large section of the *Kormoran* hull which remains intact on the seabed. This section is approximately 90 m to 95 m of the *Kormoran* hull and coincides with the un-hatched section shown in Figure 97. The bow is intact up to the start of the superstructure.

The bow section shows obvious damage from the sinking process and the effects of its masts falling onto the upper decks. However, no obvious signs of weapons damage can be identified along the hull section which remains intact.

The second feature consists of the large pieces of the aft section of the hull and superstructure which are scattered in a tangled mess within the debris field. No shell weapon damage can be derived from this section of the hull and no individual weapon event can be distinguished from the wreckage except that the damage was from an extremely large detonation.

The *Kormoran* wreck does provide sufficient information to enable the confirmation of the identity of the German Merchant raider and its weapons and camouflaging arrangements.

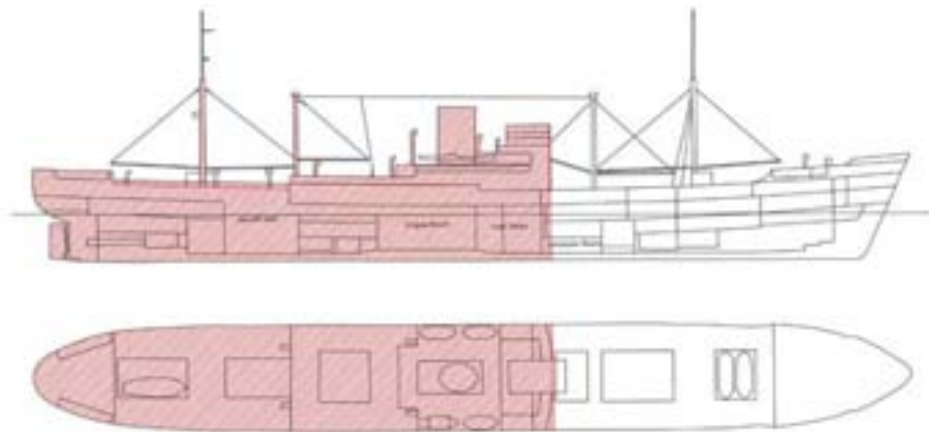

Figure 97: Extent of damage to *Kormoran* as it lies on the ocean floor [159]

#### 5.1.2 Identification of *Kormoran* guns and camouflaging

The following describes the guns and camouflaging that can be seen in the footage of *Kormoran*. Figure 98 shows *Kormoran*'s No.3 gun.



Figure 98: *Kormoran's* No. 3 15 cm gun in hold [158]

Figure 99 shows that the Forecastle deck has collapsed onto *Kormoran's* No.2 gun, most likely due to damage from the collapse of the masts and/or the sinking process, but there are no signs of weapon damage from *Sydney* shells.



Figure 99: *Kormoran's* No.2 15 cm gun forward port side [160]

DSTO-GD-0559



Figure 100: *Kormoran's* No.1 15 cm gun forward starboard side [161]

Figure 100 shows that the Forecastle deck has collapsed onto *Kormoran's* No.1 gun, most likely due to damage from the collapse of the masts and/or the sinking process, but there are no signs of weapon damage from *Sydney* shells. The hinges for the camouflaging plates can be identified on the Forecastle deck.



Figure 101: *Kormoran's* 2 cm gun forward port side [162]

Figure 101 shows the forward port side 2 cm gun, with the camouflaging cover open next to it.





*Figure 102: Kormoran's 2 cm forward starboard gun [163]*

Figure 102 shows the forward starboard 2 cm gun. The figure shows the gun platform is separate from the deck allowing for the gun to be raised from below the deck.

### 5.1.3 Above-water Torpedo



*Figure 103: Above water torpedo flap starboard side [164]*

DSTO-GD-0559



*Figure 104: Above water torpedo flap port side [165]*

Figure 103 and Figure 104 show the flaps used to camouflage the starboard and port side above water torpedo tubes. Unfortunately the ROV was unable to view into the space below the flap to observe the torpedo tubes.

#### 5.1.4 Below-water Torpedo tube



*Figure 105: Below water torpedo tube starboard side [166]*



Figure 106: Below water torpedo tube port side [167]

Figure 105 and Figure 106 have been identified as the underwater torpedo firing tubes.

The weapon mountings and locations that are identifiable on the bow section of *Kormoran*, match those provided by the drawing of *Kormoran* [159] and highlighted in green in Figure 107. The other weapons cannot be identified due to the wreckage of the aft section of *Kormoran*.

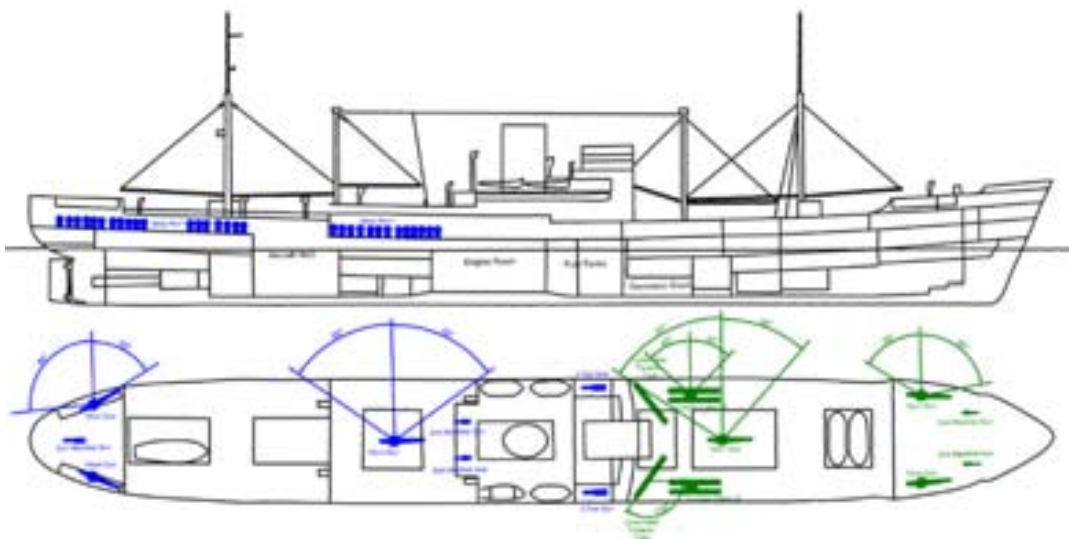

Figure 107: Weapons identified within the wreckage are marked as green and match those presented in reference material [148].

### 5.1.5 *Kormoran*'s vulnerability to shell fire

*Kormoran* was built as a merchant vessel and no information is available of any protective armoring of the structure or magazines. *Kormoran* was well armed and its distribution of weapons over the entire length of the ship meant *Kormoran*'s war fighting

DSTO-GD-0559

capability was extremely difficult to knock out with the use of 4" or 6" shells. To stop this firepower would require a minimum of four accurately placed shells extending the length of the ship to disable the four 15 cm guns able to fire broadside. *Kormoran* would then still have the torpedo tubes both above and below the waterline to use as its major offensive weapon.

The lack of armour to the engine rooms made these positions vulnerable to AP shell hits penetrating into the engine room and disabling the mobility of the ship.

*Kormoran's* greatest vulnerability to an HE shell was the large stowage of mines which the ship could carry. *Kormoran* could stow 360 EMC mines each having an explosive weight of 290 kg (as shown in Figure 108), and these were stored above the waterline in a large compartment space extending along most of the aft structure (as shown in Figure 109). The location of these mines above the waterline made *Kormoran* vulnerable.

Detonation of one of these mines would result in a mass detonation of over 100 tonnes of explosive in this area and totally destroy the rear of the ship. Figure 110 illustrates the extent of the damage as predicted using XVAM.

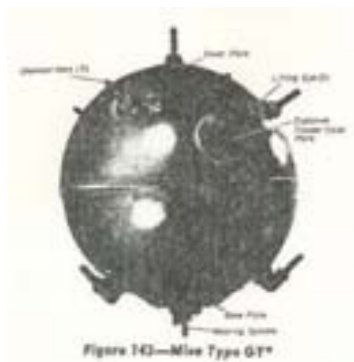

Figure 108: German EMC mine [168]

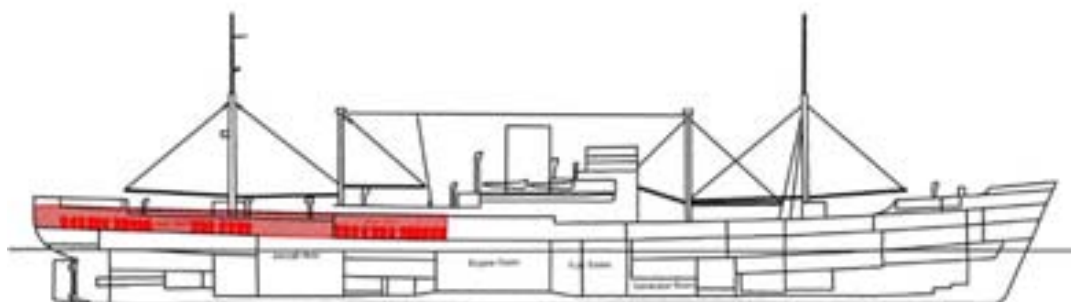
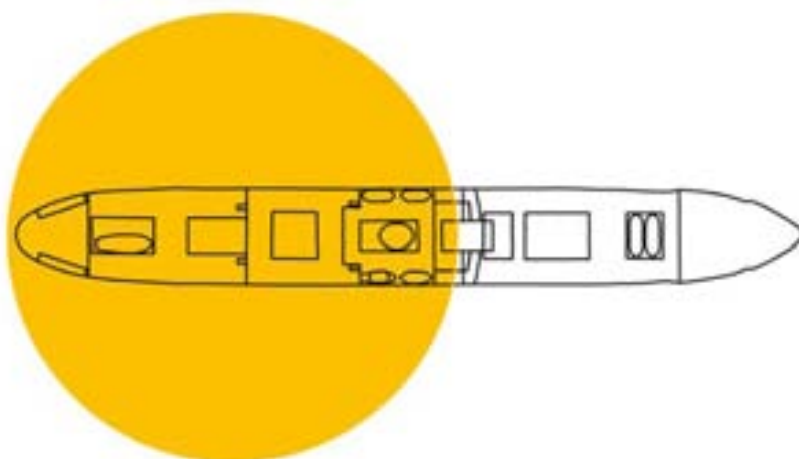

Figure 109: The stowage of mines extended for a large section of the aft end of *Kormoran*. The stowage area is exposed to any HE shells due to the section being above the waterline.



*Figure 110: Extent of damage resulting from mass detonation of mines*



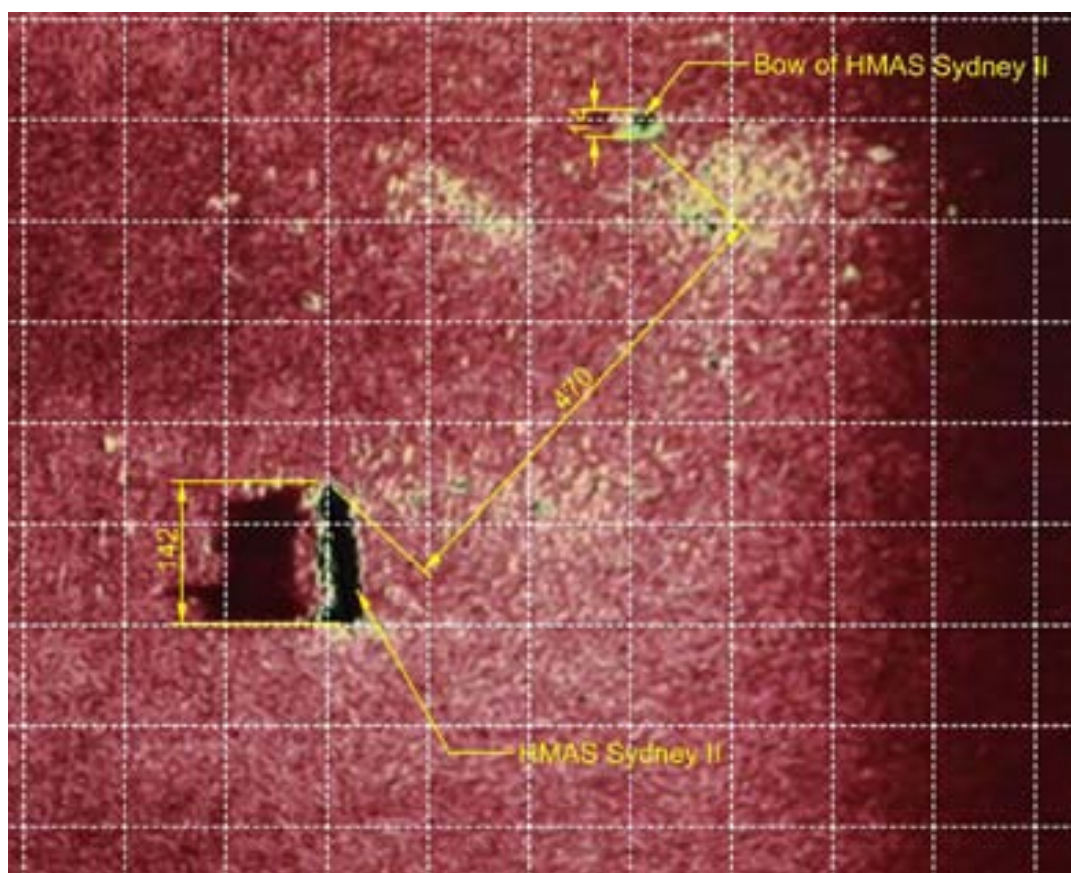

Figure 112: Sydney debris field showing main structure and bow (dimensions in m) [170]

### 5.2.2 Torpedo Damage

The bow of *Sydney* lies inverted on the ocean floor on its starboard deck edge (see Figure 113). The bow section shows significant damage due to it tearing apart from the main hull section and its final impact with the ocean floor. However the tear along the port side of the bow appears largely undamaged from these effects and from this section it is possible to show that the bow has broken off at frame 19.

DSTO-GD-0559



Figure 113: Forward section of the inverted bow resting on the ocean floor [171]

Damage close to the port side of the bow's keel shows the typical concave indentation of an explosion on this surface consistent with torpedo damage (see Figure 114). This damage indicates that *Sydney* was hit by a torpedo on the port side. As the hole edge is at frame 19, the detonation occurred aft of this frame, at a frame between frame 19 and frame 30. The probable detonation location from the evidence would be in the vicinity of Frame 25, around the Type 125 Sonar Dome (as shown in Figure 115 and Figure 116).

The flaring on the starboard side panels shown in Figure 117 indicates that the damage from the torpedo detonation on the port side has progressed and, either caused a hole or bulging on the starboard side of the hull. The fresh water tanks in the vicinity of the detonation would have been one mechanism that would have transferred the explosive energy from the port to starboard side resulting in this flaring. It is not uncommon for torpedo damage to penetrate both sides of the ship, as is demonstrated by damage to USS St. Louis in Figure 118.

Figure 119 shows significant damage to the internal structure inside the bow, with the decks and bulkheads lying at the top of the inverted bow section. The heavy anchor cable is still attached and can be seen trailing out of the break in the hull. It is likely that the collapse of the deck has occurred as a result of the sinking process and would not have been a direct result of the torpedo detonation.





Figure 114: Break in bow on Port side showing indentation due to torpedo detonation [172]

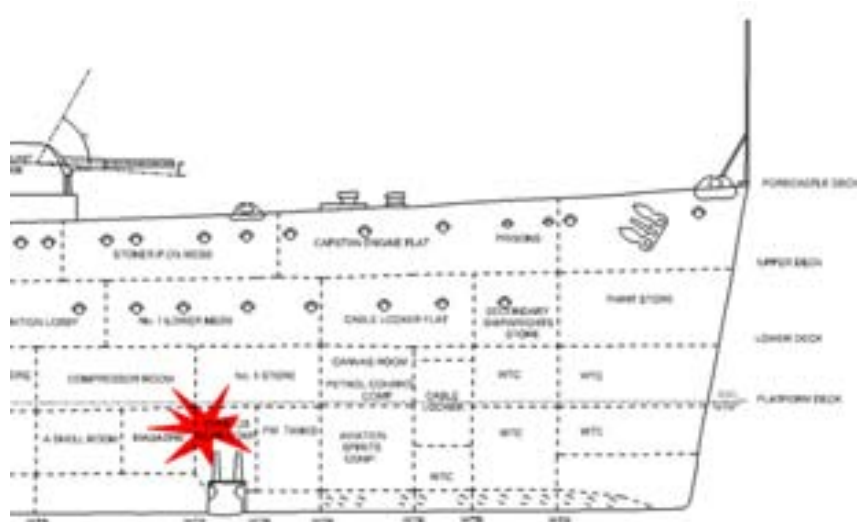

Figure 115: Probable Torpedo detonation location on the port side based on evidence from the wreckage. (Profile shown is of the starboard side)

DSTO-GD-0559

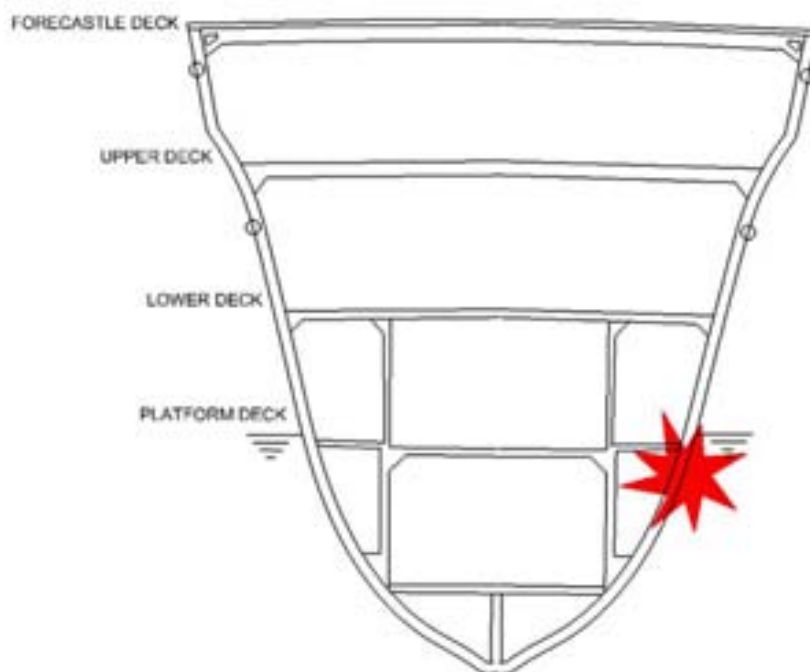

Figure 116: Probable Torpedo detonation location on the port side based on evidence from the wreckage site.



Figure 117: Flaring on the starboard side panels indicating that the torpedo either caused a hole or bulge on the starboard side [173]



Figure 118: Torpedo damage to USS St. Louis in July 1943. This damage has penetrated through the hull [174].



Figure 119: Internals of the bow show collapsed decks and connected anchor chains [175]

The main section of the wreckage of *Sydney* shows that significant secondary damage has occurred from a number of mechanisms, the torpedo explosion, the ripping of the bow from the main hull section during sinking, the force of the water flowing over the ship during sinking and the impact of the main hull section on the ocean floor.

The Forecastle deck plating on the starboard and part of the port side is bent downwards, as shown in Figure 120. The Forecastle deck plates can be identified as matching frame 19, and have separated at the end of the wooden decking. Figure 121 shows that on the port side a large section of deck plate has been wrapped around the barrels of A Turret.

DSTO-GD-0559



*Figure 120: Tear in Forecastle deck on main hull [176]*



*Figure 121: Forecastle deck wrapped around A Turret [177]*

Examination of the main hull section on the starboard side shows a large section of hull plate that has been torn and bent right past the A turret to frame 35. Figure 122 shows that a large section of the hull plate has been bent upwards on the starboard side. This damage may have been attributed to a detonation in the forward magazine, but this theory has been discounted by considering video footage of the ship which shows that the bulkheads surrounding the major magazine in this region to be intact. Due to the angle of the ship, a large amount of debris and limited footage of this region, it is difficult to differentiate between damage due to the torpedo, subsequent damage to the hull and damage due to the sinking process.



Figure 122: Starboard side of main hull bent upwards [178]

On the port side, the hull plate has been torn back at 90° to the rest of the hull (see Figure 123). It is highly likely that this bend is due to a combination of the torpedo damage weakening the hull structure and the loading on the hull during the sinking. Once again it is difficult to differentiate between torpedo and sinking related damage.



Figure 123: Port side of hull bent 90° to the rest of the hull [179]

The extent of damage to the port and starboard side of the ship due to the combination of torpedo and sinking damage makes it very difficult to definitively determine the size of the torpedo damage.

Without being able to define an accurate damage radius and detonation location it is difficult to analytically evaluate the size of the charge used in the torpedo, but the damage sustained is consistent with that expected from a single torpedo with a 280 kg warhead detonating close to the port side of the hull. An approximate shape is provided in Figure 124 showing the extent of damage sustained on the port side by the torpedo.



damage to the port, starboard and unidentified locations is provided in Table 18, Table 19 and Table 20 respectively. It is difficult to provide a definite number of hits as a single shell shot can produce multiple penetrations in the structure. Figure 125 to Figure 133 present the location of the damage identified on *Sydney* that is thought to be a result of weapons effects. The damage on these drawings is shown to scale, based on approximate measurements of the damage taken from the photographs captured by the ROV. These figures show extensive damage to the port and starboard side of the ship.

Table 18: Summary of weapon hits observed in the port side of *Sydney*

| Location     | Contact Detonation | Shell Penetrated | Not Penetrated | Unknown  | Total     |
|--------------|--------------------|------------------|----------------|----------|-----------|
| Structure    | 17                 | 14               | 2              | 1        | 34        |
| A Turret*    | 2                  | 2                | 0              | 0        | 4         |
| B Turret*    | 1                  | 0                | 0              | 0        | 1         |
| Catapult*    | 2                  | 0                | 0              | 0        | 2         |
| <b>Total</b> | <b>22</b>          | <b>16</b>        | <b>2</b>       | <b>1</b> | <b>41</b> |

Table 19: Summary of weapon hits observed in the starboard side of *Sydney*

| Location           | Contact Detonation | Shell Penetrated | Not Penetrated | Unknown  | Total     |
|--------------------|--------------------|------------------|----------------|----------|-----------|
| Structure          | 13                 | 17               | 12             | 0        | 42        |
| X Turret*          | 0                  | 1                | 0              | 0        | 1         |
| DCT*               | 0                  | 1                | 0              | 0        | 1         |
| Starboard Torpedo* | 1                  | 0                | 0              | 0        | 1         |
| 4" Gun Locker      | 1                  | 0                | 0              | 0        | 1         |
| <b>Total</b>       | <b>15</b>          | <b>19</b>        | <b>12</b>      | <b>0</b> | <b>46</b> |

\* Structure can independently rotate so direction of shot needs to be determined by *Sydney* operational status at time of hit.





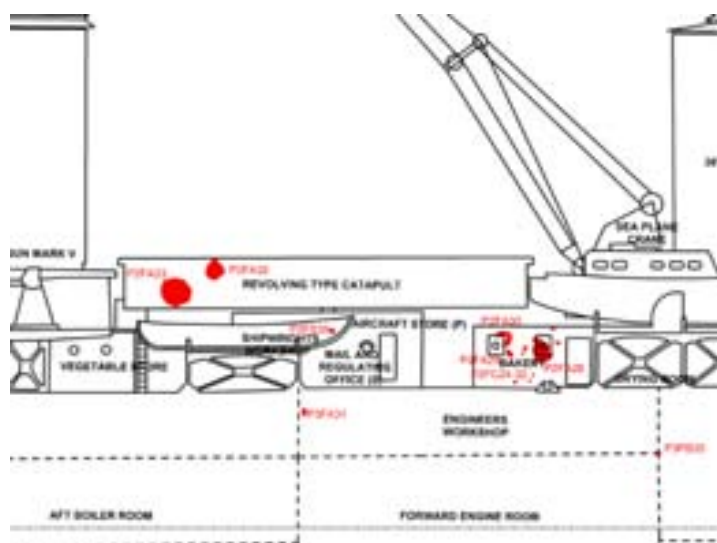

Figure 127: Location of weapon damage to port side around catapult

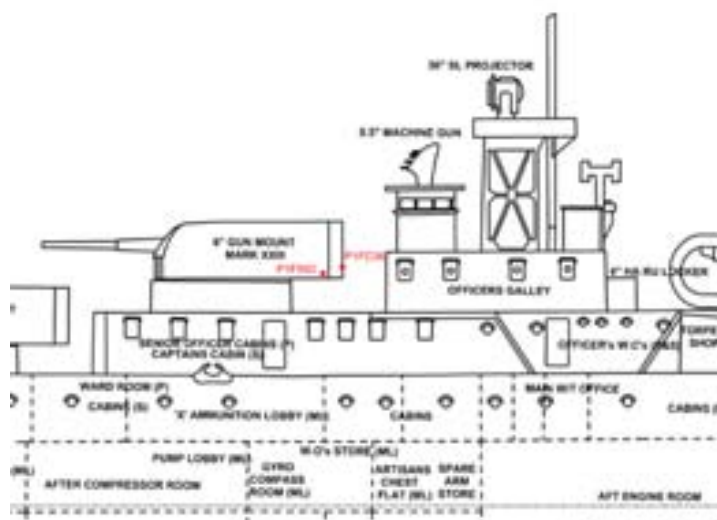

Figure 128: Location of weapon damage to port side of X Turret\*

\*Note: This damage is on the port side of the turret, but was probably due to a shell aimed at Sydney's starboard side.

DSTO-GD-0559

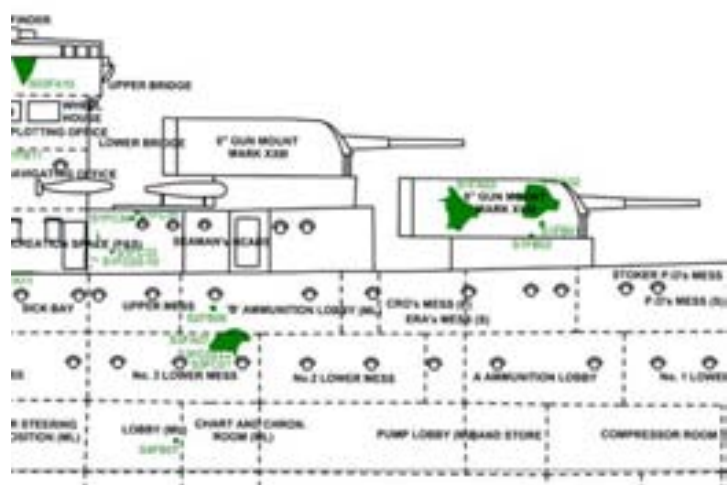

Figure 129: Location of weapon damage to starboard side around A Turret

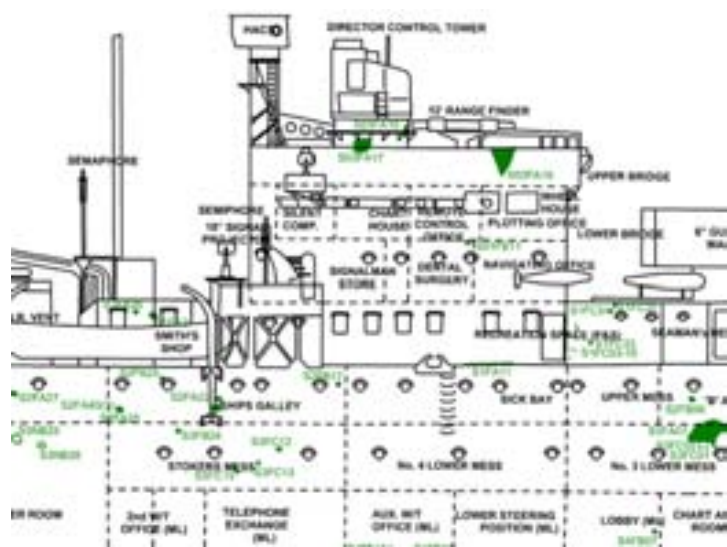

Figure 130: Location of weapon damage to starboard side around the bridge

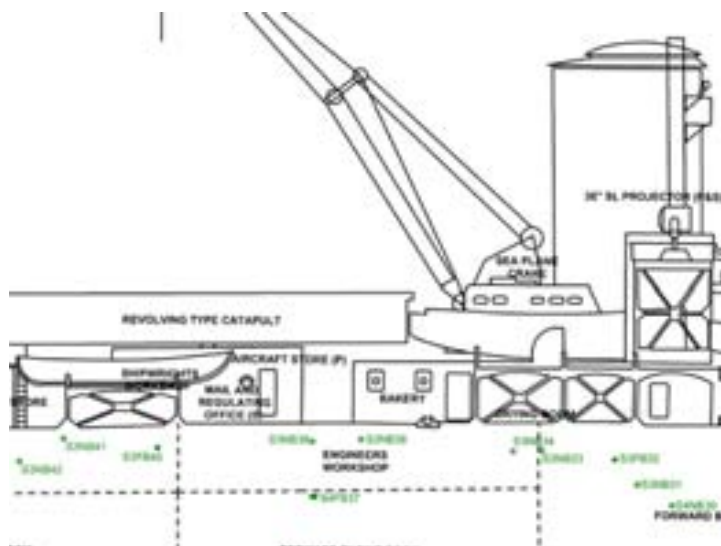

Figure 131: Location of weapon damage to starboard side around the bakery

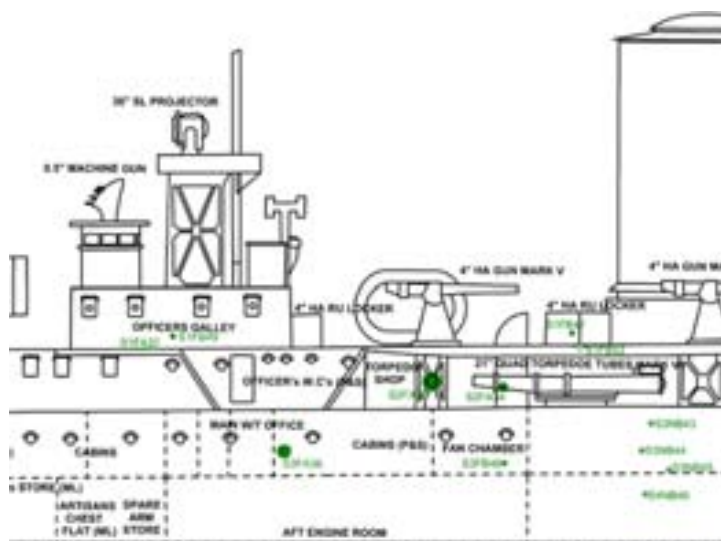

Figure 132: Location of weapon damage to starboard side around the 4" HA guns

DSTO-GD-0559

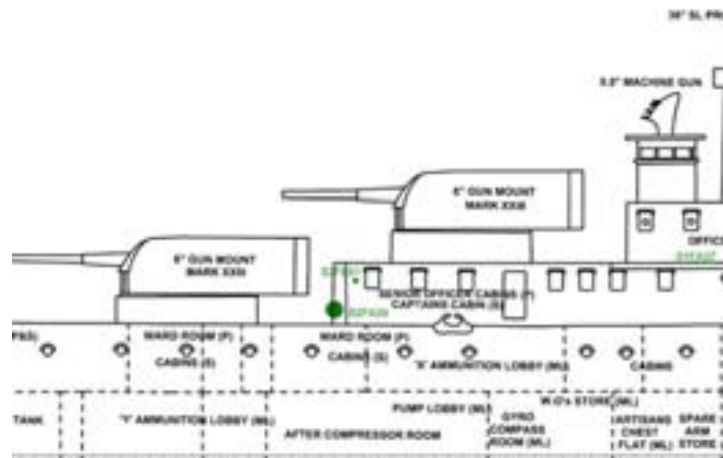
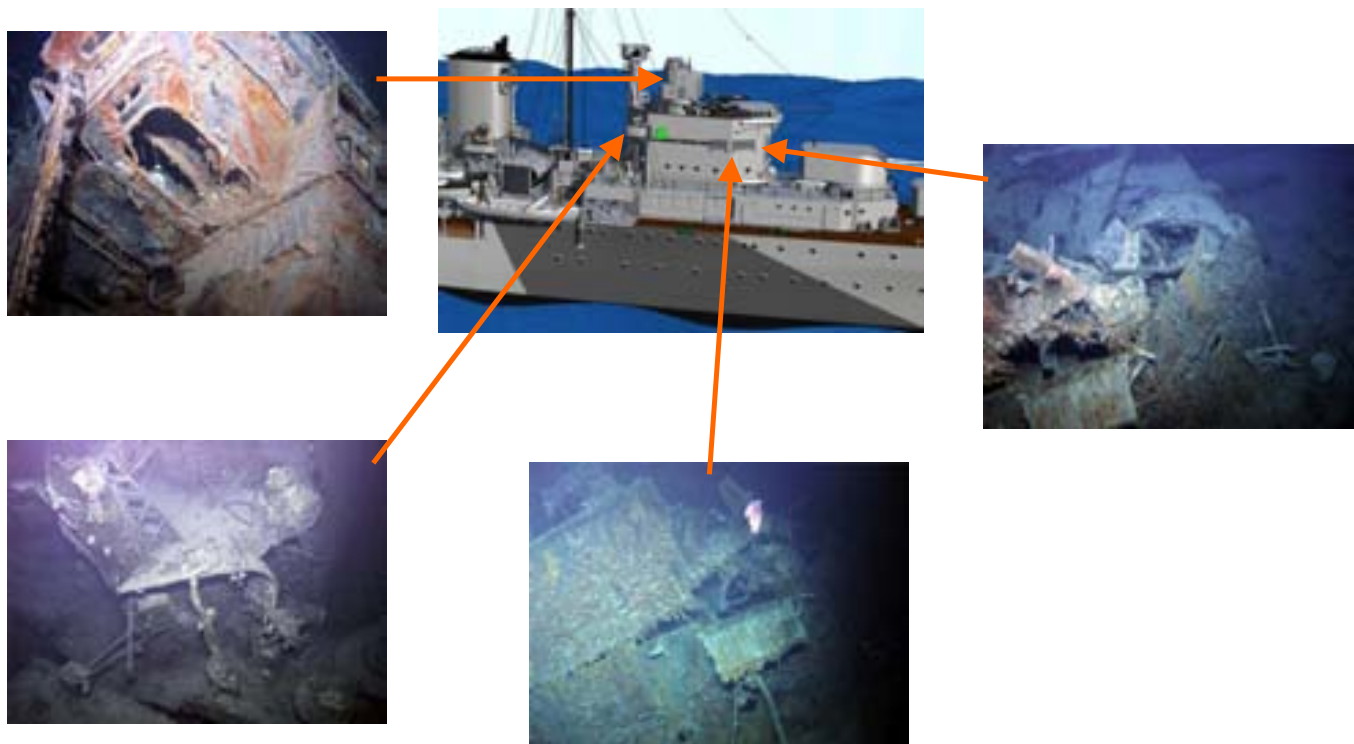

Figure 133: Location of weapon damage to starboard side around Y Turret

A more complete survey of the damage sustained by *Sydney* as a result of weapons damage, including images of the damage is provided in Appendix A.1. This section catalogues all the identified weapons hits on *Sydney*. Also in a later chapter the details of the hit locations have been used in an XVAM analysis to predict the internal damage of the ship and provide an estimate of the capabilities of *Sydney* after the battle.

Composite images of the damage caused by weapons and fire are included in Figure 134 to Figure 144.

Figure 134: Composite image of forward superstructure – starboard [180-183]



DSTO-GD-0559

Figure 135: Composite image of forward Forecastle deck – starboard [184-189]

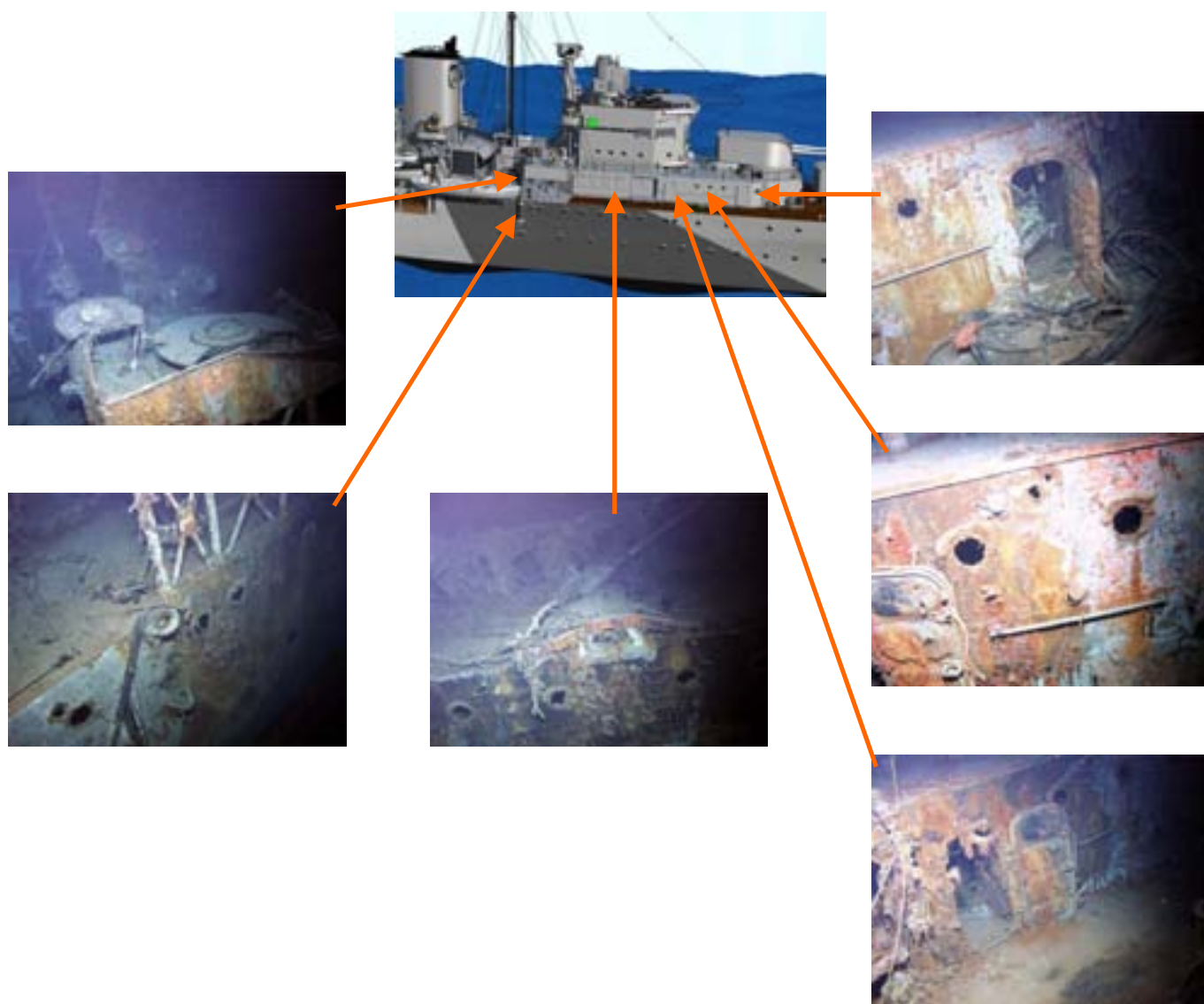
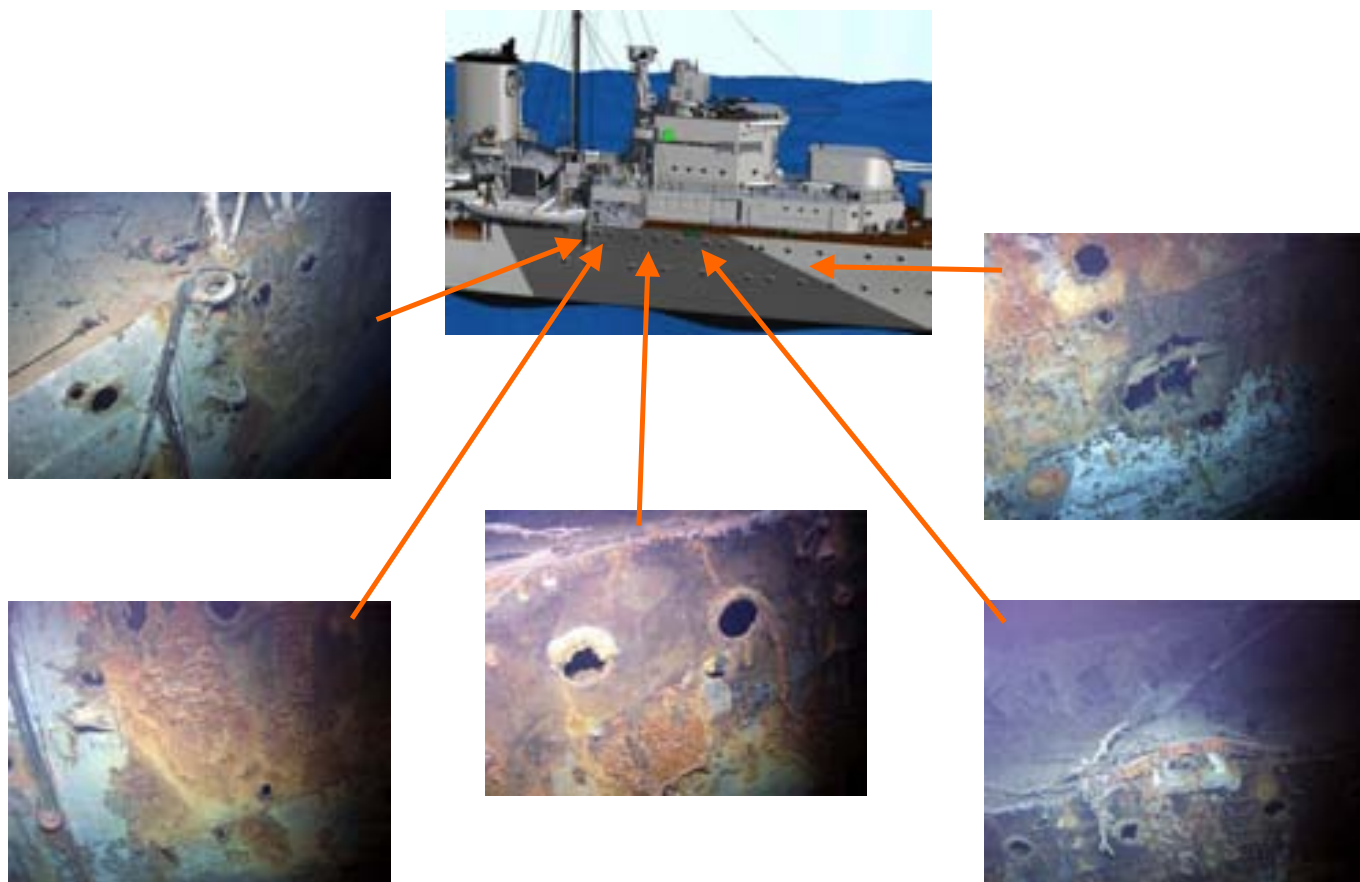

Figure 136: Forward upper/lower decks – starboard [186, 190-193]



DSTO-GD-0559

Figure 137: Forward superstructure – port [194-200]

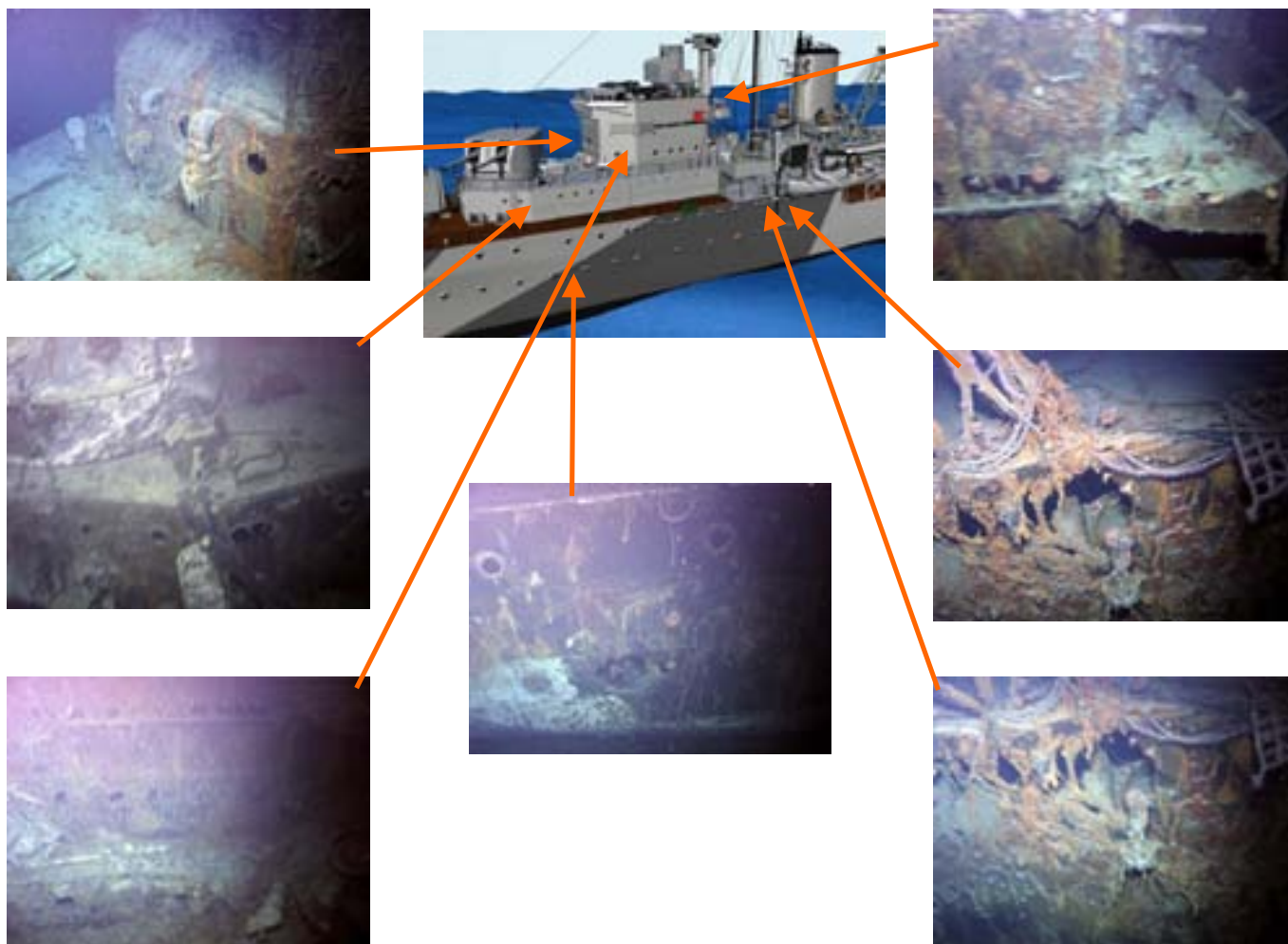



Figure 138: Smith's shop - starboard [201]



DSTO-GD-0559

Figure 139: Smith's shop – port [202, 203]



Figure 140: Midships – starboard [204, 205]



DSTO-GD-0559

Figure 141: Midships – port [206-210]

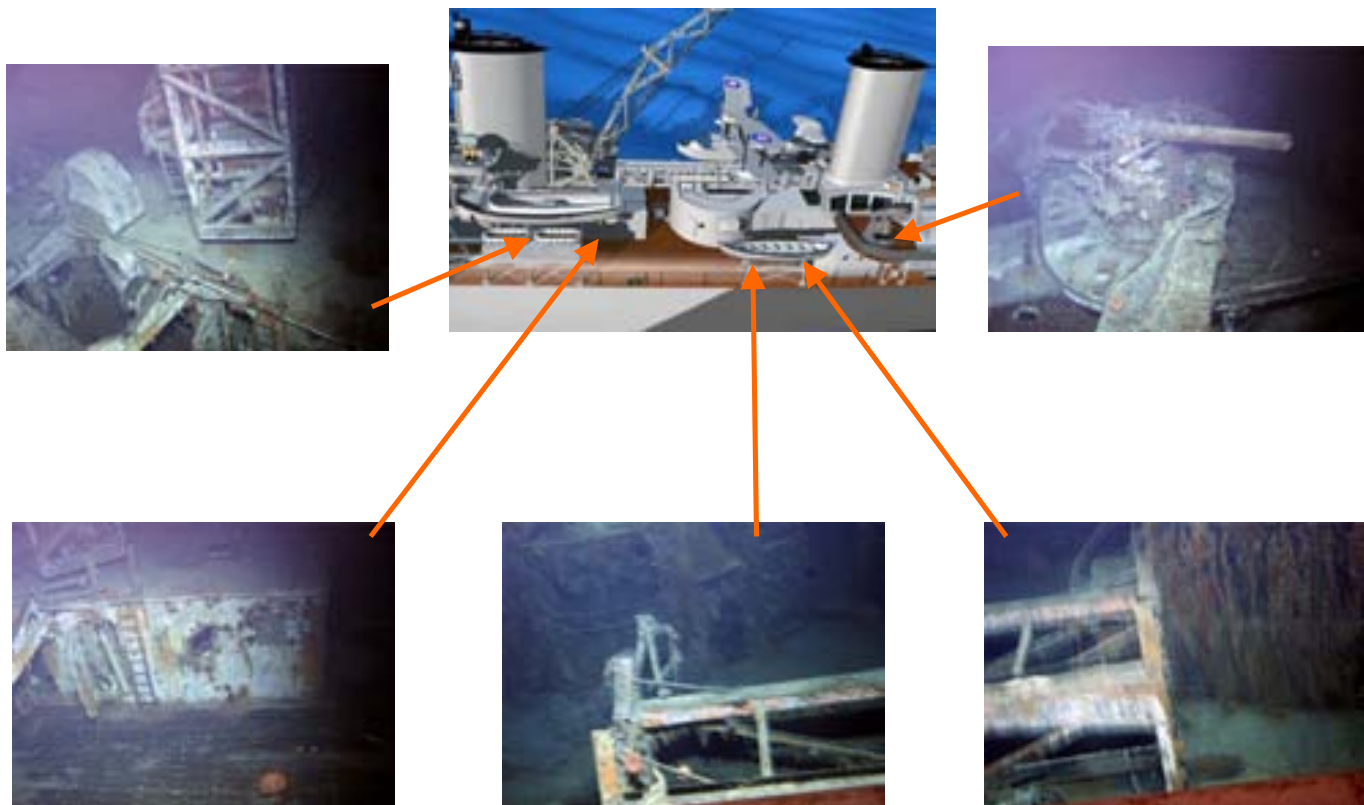
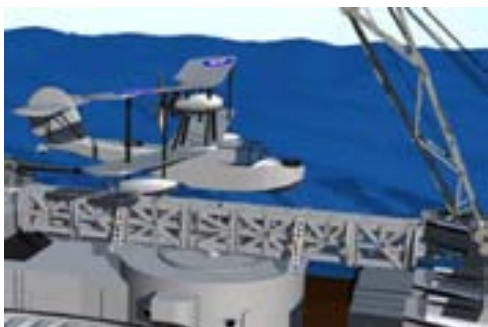

Figure 142: Midships – aircraft [211-213]



Aircraft catapult



Possibly aircraft wreckage

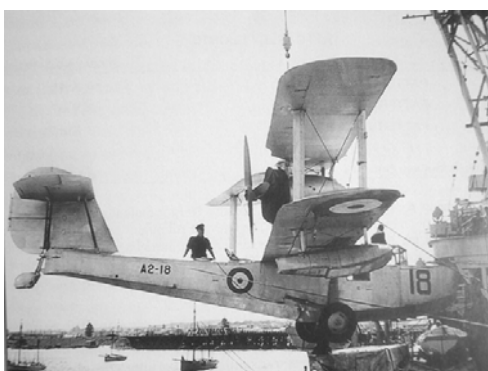

Possibly aircraft wreckage

DSTO-GD-0559

Figure 143: Aft upper decks – starboard [214-219]

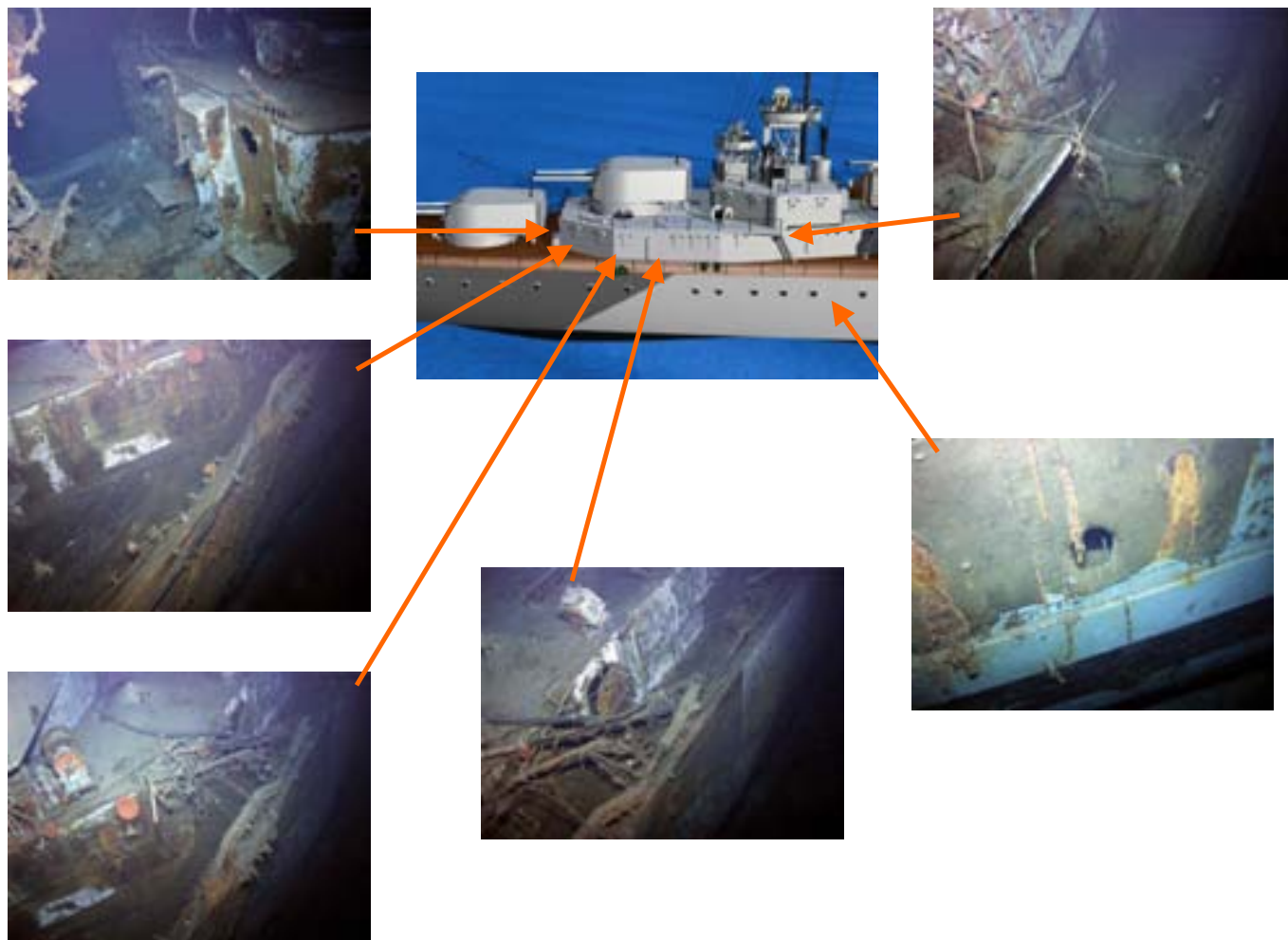

Figure 144: Aft upper decks – port [220-226]



DSTO-GD-0559

### 5.2.4 Fire Damage

Evidence of fire is based on paint damage from the ROV video and still images. Often these are accompanied by corrosion which will also occur where metal has been damaged from fragments. Corrosion can grow into rusticles due to the action of microorganisms in the sea and these are often used as evidence of fire damage (see Chapter 8). In some locations it is difficult to distinguish corrosion due to organisms from corrosion due to fire damage.

Based on observations of fire damage to ships, a survey of fire damage to *Sydney* has been undertaken. Examples of fire damage are shown in Figure 145.



Officer's galley, Forecastle deck (aft - port). Note the rusticles (see arrow).



Captain's sleeping space, upper deck (aft - starboard). Note the discoloured patches due to heat transfer from a fire (see arrow).



Recreation space/heads, Forecastle deck (forward - starboard). This photograph shows the boundary between the burnt and unburnt bulkhead (see arrow).



Canteen / dispensary, upper deck (forward - starboard). Note the blackened paint and the corrosion where the paint has been removed.

Figure 145: Examples of fire damage on *Sydney* [187, 192, 215, 227]

The ROV footage contains evidence of fire damage to three areas of the ship. The fire damage analysis is illustrated in Figure 146 and is described below.

- The entire bridge structure and across the breadth of the Forecastle deck, as well down the lower deck hull on the port, and down to the upper deck hull on the starboard side.



DSTO-GD-0559

- Midships below the aircraft platform and across the upper deck.
- The aft superstructure and upper deck on the port side and aft superstructure on the starboard side, below the aft control position. The upper deck is also burnt below X turret. The starboard hull (lower deck) is burnt around a shell impact/penetration.

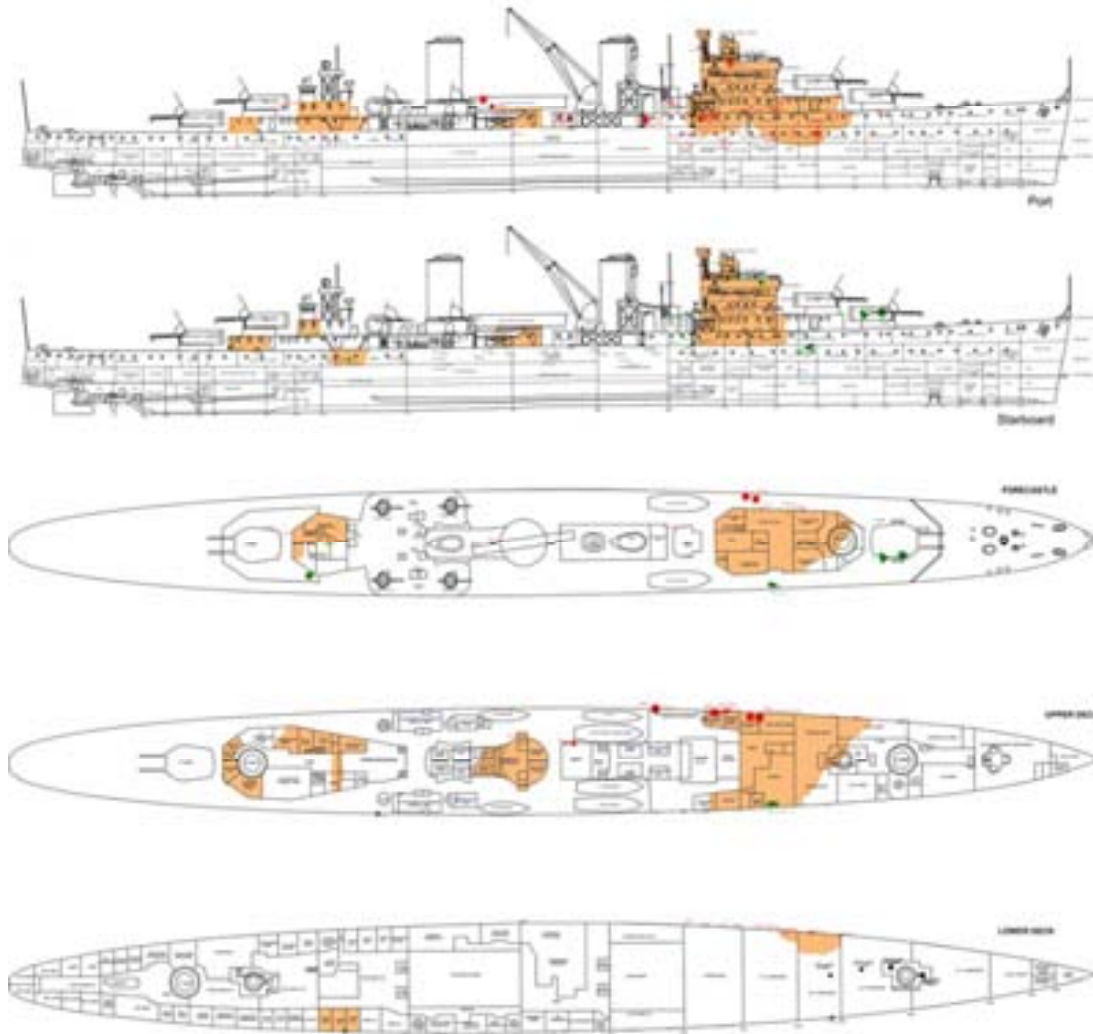

Figure 146: The areas of Sydney that were affected by fire damage are shaded in orange

### 5.2.5 Ship's boats and Carley floats

Examination of the Sydney wreck site shows that there is no evidence of any of the Carley floats in the debris field or any evidence of any still attached to the wreck.

There is also no evidence of boats still located in their original position. However, the debris field shows a number of the ship's boats lying on the seabed. Unfortunately, the time that the boats have laid on the seabed increases the difficulty in ascribing the

DSTO-GD-0559

observed physical deterioration to weapons effects or to natural degradation. It is highly likely that small holes in the boats outer planking due to weapons fragments would be the point where the physical deterioration commences. If the deterioration is significant, this makes it difficult to definitively ascribe the damage to weapons effects. The resolution of the images also inhibits the identification of small fragment impacts. However, where the planking is intact, it is possible to examine any small holes and possibly correlate them with weapons fragments.

The figures below contain photographs that were taken using the ROV. Figure 147 shows the remains of one of the carvel built 35' Motor Boats partly lying on its side and partly upside down. Some of the planking is still intact but much of it has deteriorated, exposing the ribbed frame.

Figure 147(a) shows the mid section with significant damage. It appears that the boat has almost broken in two. In the middle of the boat there are metal parts and the remains of equipment. Figure 147(b) shows the bottom of the boat and that there is little of the planking intact and the stern is missing. Figure 147(c) shows the bow of the boat with a large percentage of the planking intact and several holes, which are believed to be due to fragment impacts. Note that the paint is largely intact in several areas and that there does not appear to be evidence of fire damage.



(a)

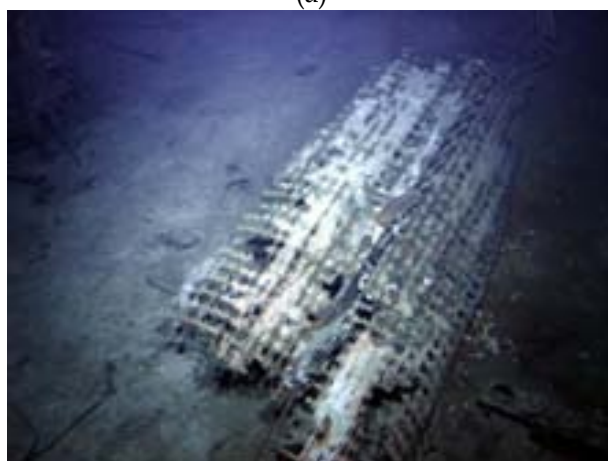

(b)

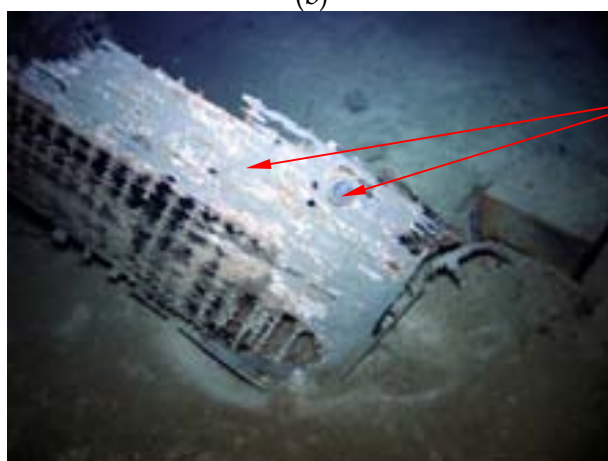

(c)

possible fragment  
impacts

Figure 147: Photographs of a 35' Motor Boat on the seabed [228-230]

Figure 148 shows the second carvel built 35' Motor Boat sitting upright on the seabed. Figure 148(a) and Figure 148(b) show the stern and the bow of the boat, which are both relatively intact and show only limited damage to the planking from fragments and/or natural deterioration. Figure 148(c) is a plan view and shows the remains of the helm

DSTO-GD-0559

and the interior equipment. Figure 148(d) shows the remnants of the motor and assorted pipe-work. It would appear that this boat is in very good condition with only limited decay of the wooden planking and the frame; the outer planking is clearly in better overall condition than the Motor Boat in Figure 147. The equipment inside (including the motor) is missing and has presumably fallen out during the sinking. The paint on the outside of the boat is in good condition and again there is little evidence of any fire damage.



(a)



(b)

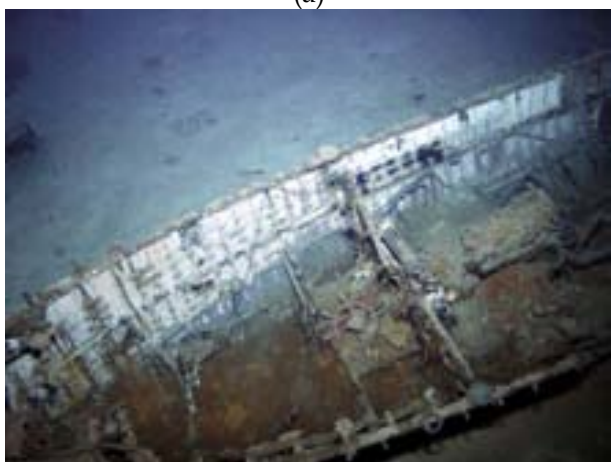

(c)



(d)

Figure 148: Photographs of a 35' Motor Boat on the seabed [231-234]

Figure 149 shows the remains of two boats, one lying on the seabed and the second one on top of the other. The boat on the seabed is the carvel built 36' Motor and Sailing Pinnace which is identified by its distinctive tiller and rudder. The boat on top is a 27' Whaler which can be identified by the curved bow and stern (the Whaler is the only boat on board *Sydney* that had this characteristic shape). Since the Pinnace was on the port side of *Sydney*, it is highly likely that the Whaler is also from the port side. Figure 149 (a) shows how the two boats are positioned on the seabed and shows that the Pinnace exhibits significantly less deterioration compared to the Whaler. The fact that the Whaler is a clinker built boat [235] may explain the extensive deterioration of the boat's planking. Figure 149 (b) shows that the planking on the Whaler has rotted away leaving

DSTO-GD-0559

only the frame behind. Figure 149 (b) also shows that a large section of the bow is missing on both the port and starboard sides. Figure 149 (c) is an enlargement of the bow section of the Whaler and shows evidence of fire damage to the frame timber which is observed in the blackening of the timber around the ship's boat badge. Figure 149 (d) is one side of the bow of the Pinnace and shows what appears to be damage to the planking caused by fragments; there are multiple penetrations to the outer timber consistent with fragments from weapons. It also shows the presence of rusticles consistent with the use of steel in the construction of this boat [236]. Figure 149(e) shows the stern of the Pinnace and that much of the interior of the boat is missing.



(a)



(b)

DSTO-GD-0559



(c)

Possible multiple  
fragment hits

(d)



(e)

Figure 149: Photographs of a 36' Motor Pinnace and a 27' Whaler on the seabed [237-241]

Figure 150 shows a 27' Whaler on the seabed. Although the images do not clearly show the characteristic shape of the bow and the stern, the frame construction is identical to the Whaler in Figure 149 (a) and Figure 149 (b). Given that Figure 149 is believed to be the port Whaler, it is probable that this is the Whaler from the starboard side. The photograph shows almost complete rotting of the boat planking but the frame is still

DSTO-GD-0559

intact (this is very similar to the other Whaler). There is some evidence of shell damage to the boat as seen by the round hole through the frame shown in Figure 150(b). There are other small sections of the boat frame that are missing but whether this is due to weapons effects, rotting or being damaged by other parts of the ship during the encounter or the sinking is difficult to determine. However, given that the boat is intact as a whole it is highly likely that the localised damage is due to weapons effects. Figure 150(c) shows the forward part of the boat with the anchor still intact.

DSTO-GD-0559



(a)



(b)



(c)

Figure 150: Photographs of a 27' Whaler on the seabed [242-244]

Examination of the ROV images of the hull of *Sydney* on the seabed show the remains of where the davits for the Cutters should be. Figure 151(a) shows an empty aft locating hole for the davit on the starboard side for the Cutter. Also clearly visible is the shell damage to the hull possibly inflicted by a 15 cm shell which would have resulted in



significant fragment damage to the 32' Cutter. Figure 151(b) shows the empty forward locating hole for the davit slightly further along the hull. This figure also shows fire damage to the hull forward of the davit holder holes. Figure 152 shows the end of the 27' Whaler cradle on the starboard side. There is fragment damage to the front of the cradle frame and also extensive shell damage to the hull below the cradle. Figure 150, which is believed to be the starboard Whaler, shows some damage to the boat that may be consistent with this weapons damage. Figure 153 shows the port side 27' Whaler cradle. Although showing signs of deterioration, there is little evidence of weapons or fragment damage. It is known that parts of the superstructure nearby were fire damaged but there does not appear to be fire damage to the cradle. Figure 154 shows the port cradle for the Gig where the two Pattern No. 20 Carley floats were located. There is clearly structural damage to the vertical support beam and also fragment damage to the horizontal top of the cradle. Figure 155 shows the forward and aft remains of the davit locating holes for the port Cutter. The figure shows significant weapons damage to this area and that the davits are missing. The fragment damage to the nearby lifeboats would have been extensive. There is also evidence of significant fire damage to this area. Composite images of the relevant locations are shown in Figure 134 to Figure 144.

DSTO-GD-0559



(a)



(b)

Figure 151: Locating holes for davits for starboard Cutter (a) aft (b) forward [185, 245]

DSTO-GD-0559

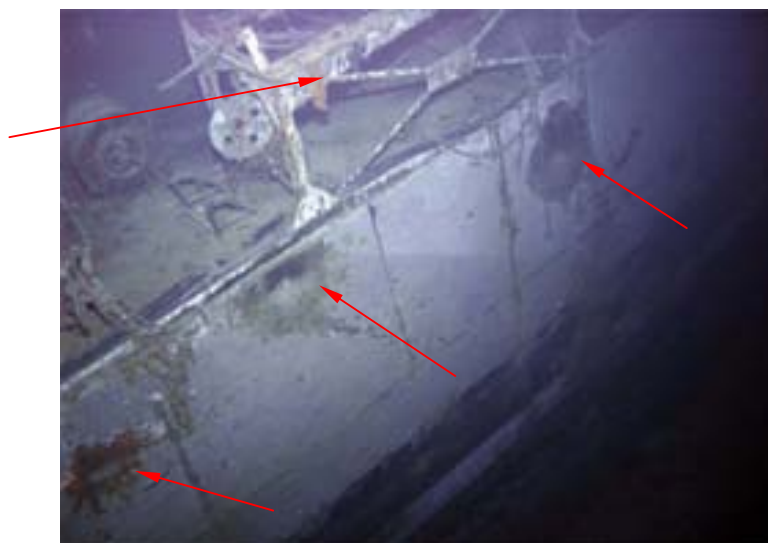

*Figure 152: Starboard side, end of 27' Whaler cradle – note fragment damage to front of cradle frame and weapons damage to the hull which would have caused major fragmentation [246]*



*Figure 153: Port side 27' Whaler cradle [247]*

DSTO-GD-0559

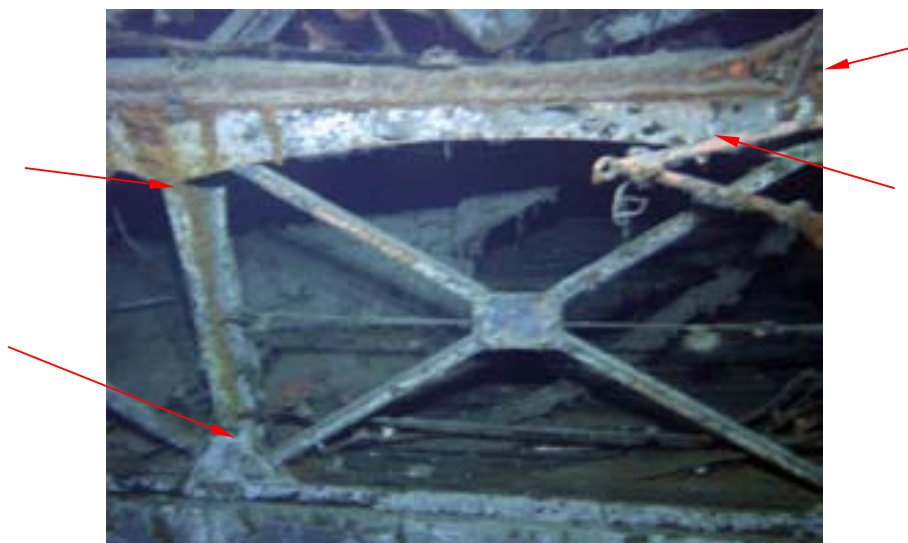

Figure 154: Port cradle for Gig (where 2 pattern No. 20 Carley floats were) [248]



(a)



(b)

Figure 155: Locating holes for davits for port Cutter (a) forward (b) aft [199, 249]

## 5.2.6 Other Structural Damage

The photographic images and video footage of *Sydney's* wreck site contains evidence of structural damage that was due to the foundering process and/or the impact of the ship with the seabed. This section identifies the locations of this type of structural damage and provides brief explanations of the likely causes. It is important to identify this damage and disassociate it from the damage sustained during the engagement.

### 5.2.6.1 Separation of the Bow

At the start of this section it was noted that the bow of *Sydney* became detached from the rest of the ship. The initiating cause was the hole associated with the torpedo damage.

DSTO-GD-0559

The extent of the torpedo hole has already been described. Upon reviewing the wreck images it is apparent that a significant part of the ship's forward structure is missing. The break in the Forecastle deck can be identified and its approximate location is shown in Figure 156. The break lies approximately where the timber deck planking ended at frame 20. The bow section lies in the debris field upside down, but there is a considerable amount of other shell and deck structure also lying in the debris field. One piece of torn and twisted side shell from the forward part of the ship is shown in Figure 157. These sections appear to have been torn away from the ship as she sank.

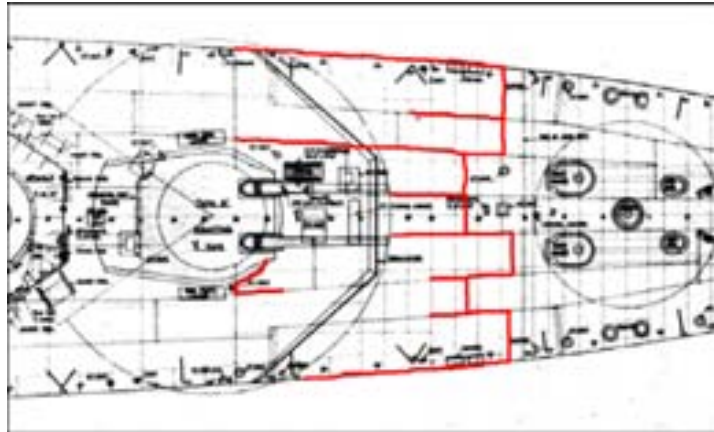

Figure 156: Approximate extent of splits in the Forecastle deck



Figure 157: A section of side shell plating torn from the ship as she sank. The section includes two side scuttles, one of which had been blanked. [250]

The break in the Forecastle deck, which can be seen in Figure 158, shows that the deck plates are torn along the seams and possibly the butt joints. The lower part of the hull structure and the aft end of the upturned bow appears to be torn rather than crushed. This indicates that the bow was torn off and pulled away from the hull rather than falling off.



Figure 158: The break in the Fore-castle Deck looking down towards the ship's keel [251]

#### 5.2.6.1.1 Implosion damage

Implosion damage is caused when an airtight container has pressure applied externally to a level at which the container collapses. The failure is associated with excessive buckling of the structure. Implosion damage occurs to many ships during sinking, particularly those which sink rapidly before all spaces within the ship have filled with water. For example, the wreck of the cruiser USS *Quincy*, lost during the battle of Savo Island, shows very similar implosion damage to that evident on the wreck of *Sydney* [252]. Figure 159 shows the forward section of the ship's upper Deck on the starboard side. The upper Deck has collapsed downwards and the side shell bent inwards over an extensive length, possibly as far forward as the watertight bulkhead at frame 154.



Figure 159: *Sydney's* upper Deck on the starboard side between frames 157 and 151, looking forward [253]

The quarterdeck bollards on the port side of the upper Deck at frame 196 aft are shown in Figure 160. The deck has been forced down several feet, exposing the capstan shaft on the ship's centreline and bending the ship's side slightly inwards.

DSTO-GD-0559



*Figure 160: Quarterdeck bollards on the port side of the upper Deck aft [254]*

Moving further aft, as shown in Figure 161, there is significant collapse around the stern section.



*Figure 161: Collapsed structure at the stern of Sydney [255]*

The extent of this buckling and collapsing damage therefore extends from the stern through to about frame 154. The damage is evident on both sides of the ship. Figure 162 shows a plan of the upper deck marked with the extent of the collapsed region. Also shown in the diagram are two thick red lines indicating where there are splits between the upper deck and the Y turret barbette.



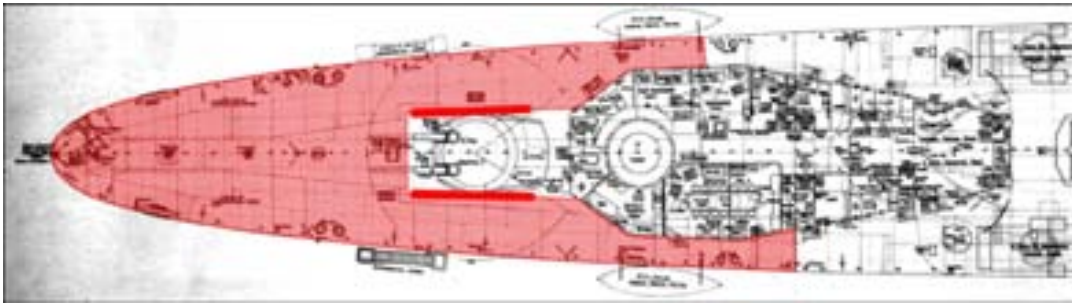

Figure 162: Upper deck plan showing the extent of the collapsed region

The split between the upper deck abreast of the Y turret is shown in Figure 163. The plate on the forward part of the barbette is also detached.



Figure 163: Split in the deck abreast of Y Turret on starboard side. [256]

#### 5.2.6.1.2 Impact with the seabed

The main hull of *Sydney* shows some evidence of damage caused when the ship impacted with the seabed. The stern section shows some signs of collapse where it has come to rest on the seabed, shown in Figure 164, although some of this damage is likely to be caused by implosion.

DSTO-GD-0559



*Figure 164: The stern of Sydney on the seabed [257]*

Moving further forward along the seabed there is evidence that the impact with the seabed caused major damage to the propellers, shafts and the associated supporting structure. One of three-bladed highly-pitched propellers is shown in Figure 165. This is the port inner propeller and the shaft has been partly withdrawn by about 8-10'. The shaft bracket has separated from the hull and the fractured top arm is also visible. The propeller is partly buried in the sand or silt on the seabed.



*Figure 165: One of the ship's port propellers on the seabed [258]*

Further forward along the ship it becomes evident that the seabed is solid rock and there is not much silt. The impact with the seabed would have caused significant damage to the lower sections of the ship. Figure 166 shows the ship's bent starboard bilge keel resting on the seabed. The bilge keel is buckled and a section of the side shell plating below the armour plating appears to be imploded. The length of the imploded section

DSTO-GD-0559

appears to begin around the forward end of the A engine room and continues aft some distance probably to end around the bulkhead at frame 135. The extent of the missing plate is shown in Figure 167 and Figure 168.



*Figure 166: Sydney's bent starboard bilge keel. The hull penetration may be the bilge ejector discharge around frame 128. [259]*

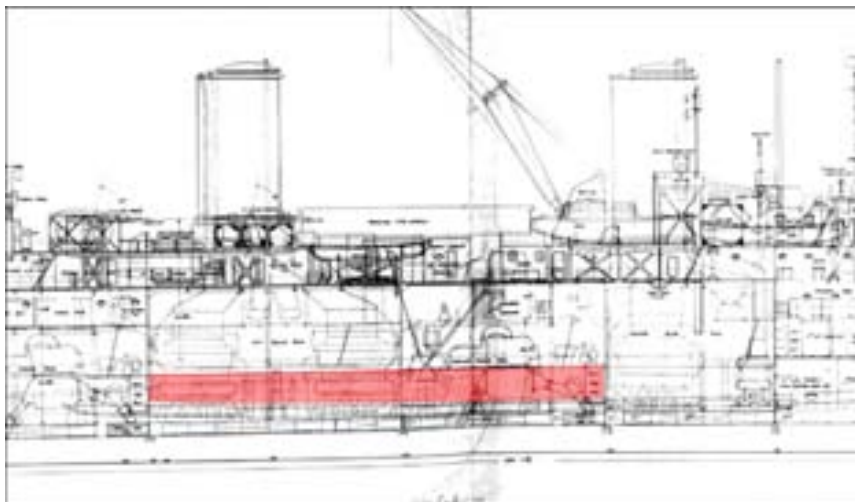

*Figure 167: Sketch showing the extent of imploded or collapsed shell plating*

DSTO-GD-0559



Figure 168: A section showing the extent of imploded or collapsed shell plating on the starboard side

Towards the forward section of the main part of the wreckage the Forecastle deck has been bent down almost 90°. This could have occurred during the sinking process, but was most likely to occur when the hull stopped on the seabed. Figure 169 shows the WT hatch forward of the A turret barbette on the Forecastle deck. The deck is clearly bent and this type of damage does not seem to be consistent with other parts of the torn bow structure identified earlier in this section.



Figure 169: WT hatch immediately forward of the A Turret barbette [260]

### 5.2.6.1.3 Collision Damage

The final type of damage that is evident from the wreck site is that associated with collision damage. As *Sydney* was sinking several large pieces of wreckage broke away from the hull including, for example the masts and funnels, and collided with other parts of the wreck. The image in Figure 170 shows the forward screen of the superstructure – near the Captain’s Sea Cabin and the Bridge.



Figure 170: The forward screen of Sydney’s bridge superstructure [261]

The front of the bridge structure is collapsed and crushed above the Captain’s Sea Cabin and the Navigating Officer’s Cabin. It is evident that the Bridge has been crushed. The starboard side of the bridge has been torn away and the port side bent in. This severe damage almost certainly occurred as the ship sank, since the bullet-proof roof over the compass platform on the upper bridge deck is lying intact in the debris field resting against the DCT. It is unlikely to have survived intact if it had not left the ship before the damage to the bridge and the upper bridge deck occurred. It is possible that some large piece of wreckage hit the bridge as the ship sank.

Collisions of this nature during the sinking would account for some of the damage to topside structure of the ship.

### 5.2.7 Damage due to deterioration

Figure 171 shows the presence of rusticles associated with the degradation of the steel of *Sydney*. Similar rusticles were found on the Titanic, which was 30 years older, as shown in Figure 27.

DSTO-GD-0559



*Figure 171: Rusticle formations on Sydney [262, 263]*

There are some cases where steel plating on the ship has deteriorated at a greater rate than adjacent plating. Examples of this deterioration are shown in Figure 172.



*Upper deck, adjacent X turret*



*Smith's Shop, port side Forecastle deck*

*Upper deck, aft of 4 inch gun deck*

*Figure 172: Deterioration of the steel plating on Sydney. [202, 221, 223, 224]*

DSTO-GD-0559

*Sydney* was fitted with a timber deck as per the ship specifications [98]. The timber on *Sydney* appears blackish in colour and is reduced in thickness. The studs securing the timber to the steel deck can be seen protruding through the remains of the timber in several areas. The caulking material appears undamaged.

Figure 173: Condition of the decking timber on *Sydney*. [214, 264-268]

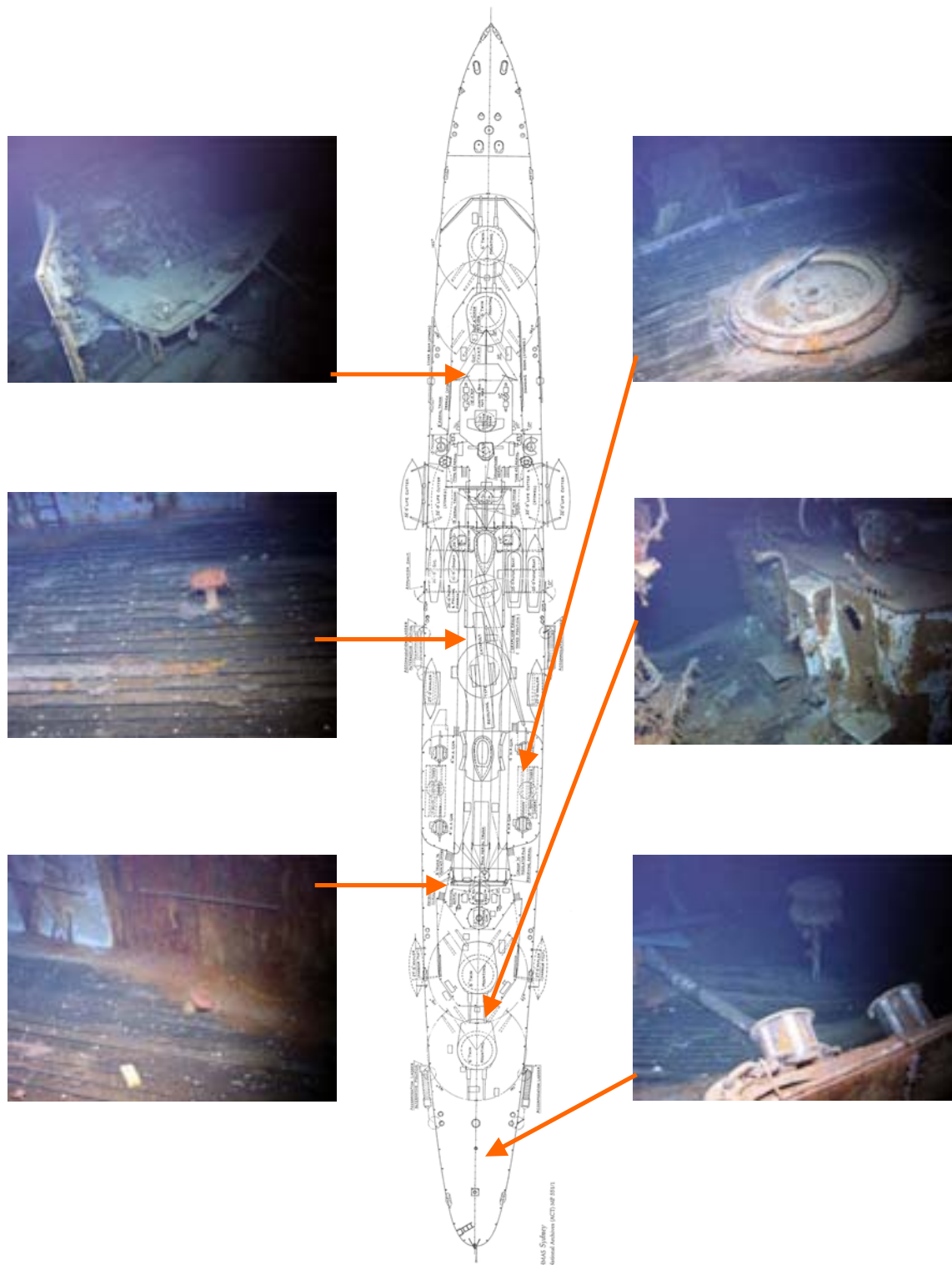

DSTO-GD-0559

It has been observed that timber decking is gone from the Titanic, and that only strips of caulking remain. It is suggested that the timber was consumed by marine animals [54].

A possibility for the condition of the timber on *Sydney* is fire. This would be consistent with the loss of thickness and colour. However, this is not supported by:

- paint on steel structure is undamaged by fire in many areas adjacent to timber decking
- the caulking materials appear relatively undamaged

The timber deck has not been considered during the assessment of fire damage.

## 5.2.8 Weapon Systems

The following are observations made of *Sydney*'s weapon systems as they now exist.

### 5.2.8.1.1 6" Guns and Fire Control

Little reliable information can be obtained because of the uncertain nature of the damage done due to the sinking. Figure 174 is a reconstruction of the approximate final locations of all guns on *Sydney*. Figure 175 shows the approximate elevation of the gun barrels on A and B Turret. Figure 176 shows a photograph of A turret. This turret has part of the deck wrapped around the guns. A photograph of B Turret is shown in Figure 177 and this turret is bearing on approximately 90° with an elevation of approximately 15°-20°. B turrets barrels also appear to be on different elevations. B Turret received a single non-penetrating shell hit to the front of the turret, and also a shell hit to the base on the port side.



Figure 174: Reconstruction of the approximate final orientation of *Sydney*'s guns





Figure 175: Reconstruction of the approximate final orientation of A and B Turrets



Figure 176: Final orientation of A Turret



Figure 177: Final orientation of B Turret

DSTO-GD-0559

Figure 178 shows the approximate final orientation of X and Y Turret. These turrets are both bearing on approximately  $45^\circ$  to port (also see Figure 174). Figure 179 shows that X Turret is elevated at approximately  $-5^\circ$ . Figure 180 shows the elevation of the Y Turret barrels, which are approximately at  $0^\circ$  and  $-5^\circ$  respectively. Y Turret appears to be essentially undamaged.



*Figure 178: Reconstruction of the approximate final orientation of X and Y Turrets*



*Figure 179: Final orientation of X Turret*



*Figure 180: Final orientation of Y Turret*

The fire control for the 6" guns was carried out by the DCT. The DCT has been located in the debris field and is shown in Figure 181. Holding up the DCT is the bridge roof. As the DCT and bridge roof are both located in close proximity to the ship, and with the rest of the equipment found in the debris field, it is suggested that the DCT fell from the ship as a result of the sinking. The forward section of the bridge is shown in Figure 182 and is extensively crushed. It is possible that the DCT has caused some of this damage as it left the ship, taking the bridge roof with it. Based on this evidence, the DCT would not have fallen from the ship as a direct result of a weapons hit prior to the sinking.



*Figure 181: DCT in debris field*

DSTO-GD-0559



Figure 182: Front of the bridge crushed

#### 5.2.8.1.2 4" HA Guns and Fire Control

The following describes the condition of the 4" Gun deck. No reliable information can be gained from the final orientation because of the secondary damage incurred during the sinking. The 4" gun deck has sustained damage on its port side, where it has been depressed downwards. The aft gun deck strut on the port side has also been damaged. On the starboard side of the gun deck, there appears to be a shell hit on the deck above the torpedo tubes. The aft gun deck strut on the starboard side has also been dislodged.

The approximate final positions of the 4" guns are shown in Figure 183. Three of *Sydney's* 4" guns (P1, P2, & S2) are still fixed to their mounts on the gun deck (as shown in Figure 184, Figure 185 and Figure 186 respectively). The forward port side 4" (P1) gun has material wrapped around its mount which is thought to be part of the aft funnel. P1 is also bearing approximately 135° port with an elevation of approximately 15°. The aft port side 4" gun (P2) is shown to be at an elevation of approximately 80° and on a bearing of around 125°. The aft starboard 4" gun (Figure 187) is bearing on approximately 135° to starboard with an elevation of approximately 15°. The fourth 4" gun (S1) can be found in the debris field.



Figure 183: Reconstruction of the approximate orientation of guns on the 4" Gun deck



Figure 184: Forward Port side 4" Gun (P1) [210]



DSTO-GD-0559

*Figure 185: Aft port side 4" Gun (P2) [269]*



*Figure 186: Forward Starboard 4" Gun mount (S1) [270]*



*Figure 187: Aft Starboard side 4" Gun (S2) [271]*

Protective plating was fitted to the guardrails around the *Sydney's* 4" gun deck. There is one piece of what appears to be side plating on the aft end of the Starboard side deck (as shown on the left hand side of Figure 187).

Four of the 'ready-use' lockers are missing from the starboard side, (see Figure 188), one of which lies in the debris field. It would appear that this locker has sustained weapons damage, or fragment damage.



Figure 188: Missing 'ready use' lockers on starboard side of 4" gun deck [272]

The fire control for the 4" guns was controlled by the HACS. The HACS can be found in the debris field (see Figure 189) and was likely lost early on in the battle due to a direct hit to the base of the HACS tower. This would have affected the accuracy of any fire from the 4" guns. There is evidence of significant damage to the starboard side superstructure below the HACS which could be attributed to the HACS falling shortly after being hit.



Figure 189: Damage to the HACS tower [273]

#### 5.2.8.1.3 Small Calibre Weapons

*Sydney's* quad machine guns are no longer on the decks (for example see Figure 190). It is likely that these guns were washed off the deck during the sinking.

DSTO-GD-0559



Figure 190: Mounting for 0.5" quad machine gun [274]

#### 5.2.8.1.4 Torpedoes

Analysis of the ROV footage of *Sydney* wreck shows that both port and starboard torpedo tubes have separated from their mountings. The remains of the torpedo tubes can be found in the debris field.

Figure 191 shows that the 4" HA gun deck above the port side tubes has been deformed downwards. This damage is possibly from secondary damage and is probably not a direct result of weapons damage. The aft strut supporting this deck has collapsed.



Figure 191: Collapsed deck over portside torpedo mount [275]

There is possibly evidence of smaller calibre weapon damage to the hull below the port side tubes, but it is difficult to tell definitively if this damage is due to smaller calibre weapons mainly because of a lack of resolution.



DSTO-GD-0559

Below the starboard torpedo tubes there are four non-penetrating 15 cm shell hits (Figure 192) and it is possible that the torpedo tubes were damaged from fragments generated by these detonations.



Figure 192: 15 cm shell hits below starboard torpedo mounting ring [276]

Both torpedo tube mounts can be found lying inverted in the debris field. One of these tubes contains two torpedoes and the other has three torpedoes.

Figure 193 shows the torpedo tubes containing three torpedoes. The torpedoes in these tubes have suffered damage, with the outermost torpedo showing the most damage.



Figure 193: Starboard torpedo quad tubes showing damage to its three remaining torpedoes [277]

Figure 194 shows a diagram of the internal details of a 21" torpedo. This shows that the damage to the torpedoes has occurred between the warhead and the air cylinder of the torpedo. If a shell had damaged the warhead of the torpedo, a sympathetic detonation

DSTO-GD-0559

would have occurred. This is obviously not the case as the torpedoes and tubes are still relatively in one piece.

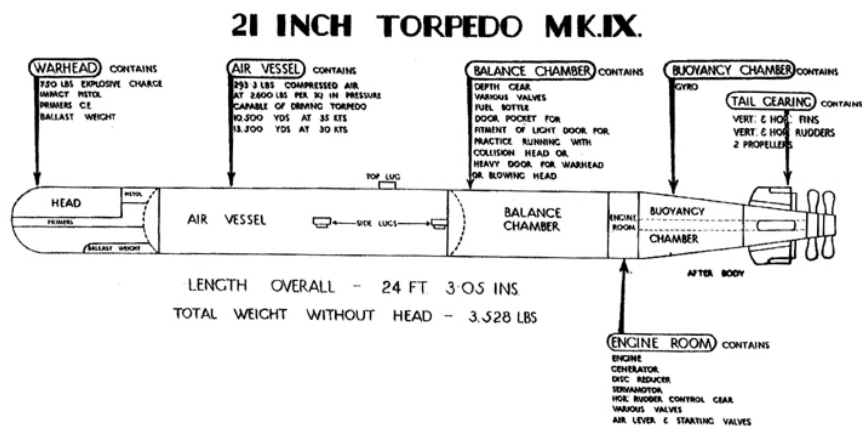

Figure 194: Diagram of the 21" torpedo [72]

The original location of the torpedo tubes has been identified by two means. The initial method was from the general arrangement drawings [3] which show the tubes arrangement. Figure 195 shows the presence of the torpedo tube platform and manoeuvring gear on the inner side of the torpedo tube. This identifies the tube as coming from the starboard side.



Figure 195: Starboard quad tube identified by the platform on the upper left hand corner of the photograph [278]

Another indicator used in identifying the original location of the tubes was the presence of letters embossed on the end caps of the tubes, which were originally used to indicate the firing sequence of the torpedoes. Figure 196 shows the presence of embossed letters labelling the tubes with the letters 'Q' and 'Z' on the two outer tubes for a more detailed view, see enlarged views in Figure 197. This identifies the quad tubes as starboard. This means that the starboard torpedo tubes still contain 3 torpedoes. It can be deduced that

DSTO-GD-0559

the 3 remaining torpedoes fill the first three positions (Q-X-Y) of the Starboard firing sequence, with the last torpedo (Z) missing.



Figure 196: End caps of starboard quad tubes showing embossed lettering [279]



Figure 197: Enlarged views of end caps from starboard torpedo tube

The torpedo tube containing two torpedoes is shown in Figure 198. The side of the left most tube in Figure 198 has been bent inwards on its forward end. This is probably a result of damage sustained as the tubes hit the seabed. The platform and the manual manoeuvring gear are missing.

DSTO-GD-0559



Figure 198: Port torpedo quad tubes containing two torpedoes [280]

Figure 199 shows the end caps of the torpedo tubes containing the two torpedoes, the outer end cap has an embossed inverted letter 'E' clearly visible along with what appears to be the letter 'R'. These are the last two tubes in the Port firing sequence (F-I-R-E) mentioned previously.



Figure 199: End cap of port quad tube has the letter E embossed on outer tube [281]

Figure 200 shows a lone torpedo that has been located in the debris field. This torpedo has been damaged towards the rear, it is possible that this torpedo could have been damaged by the sinking process. This is supported by the fact that the portion that is damaged would have been protected by the tubes. It is not possible to determine which torpedo tube this torpedo is from.



Figure 200: A torpedo in the debris field [282]

Including the torpedoes in the tubes, a total of six unfired torpedoes have been located out of *Sydney's* full complement of eight torpedoes [3]. *Sydney* did not carry any additional torpedoes to reload the tubes after firing [76].

It is not possible to tell from the ROV images whether *Sydney's* torpedo tubes were manned during the engagement, or whether the torpedo tubes indicate whether the crew at the tubes were at 'Action Stations' or not.

It is stated in some of the German survivor accounts that four torpedoes were fired by *Sydney* after turning to port. This is very unlikely as only two of *Sydney's* torpedoes are unaccounted for.

## 6. Assumptions

The analysis of the action between *Sydney* and *Kormoran* was bound by a number of assumptions concerning the battle sequence, the environmental factors and other operational aspects [71, 283]. These assumptions were provided by the Commission of Inquiry.

### 6.1 The course of the interception and encounter between *Sydney* and *KORMORAN* [283]

1. At this stage of the Commission's investigation, DSTO is requested to make the following assumptions regarding the course of the encounter between *SYDNEY* and HSK *KORMORAN*:
2. On Wednesday 19 November 1941, *SYDNEY* was sailing on a southerly course from the Sunda Strait towards Fremantle.
3. At noon on 19 November 1941, *KORMORAN* was on a course of 25° at a speed of 11 knots per hour. Her position was 111° East and 26° 34' South. There was a medium swell from the south west with a sea state 3. Visibility was very clear.
4. At 1655H, a lookout in *KORMORAN*'s crow's nest sighted a vessel on *KORMORAN*'s port bow bearing about 20° south west. After the initial sighting, amendments were continually made to the description. The initial identification changed to two sailing ships, then to several vessels, then to two smoke columns, apparently indicating the presence of an escort vessel.
5. Shortly before 1700H, an alarm sounded on *KORMORAN*. *KORMORAN* turned port to 260° and increased speed to her full speed, 14 knots per hour.
6. At 1700H, the vessel sighted by *KORMORAN* was identified as a PERTH-class cruiser. *SYDNEY* continued on a southerly course. *KORMORAN* adjusted her course to 250°, into the direction of the sun.
7. *KORMORAN* started to emit thick smoke from a breakdown from her number 4 engine.
8. At 1705H, *KORMORAN*'s engine room reported to the bridge problems with the number 4 engine.
9. At about the same time, *SYDNEY* changed course and turned in the direction of *KORMORAN*. When *SYDNEY* changed course, she was 15,000 m from *KORMORAN*. *SYDNEY* began to signal continually by light "NNJ". *KORMORAN* hoisted the signal for STRAAT MALAKKA.
10. At 1735H, *KORMORAN*'s number 4 engine was repaired and working on eight cylinders. When *SYDNEY* was 8,000 m from *KORMORAN*, *KORMORAN* ceased measurement with her 3 m range finder in order to maintain disguise. *KORMORAN* continued to find the range to *SYDNEY* using her 1.35 m range

finder. In the meantime, there was a continuous exchange of signals between the two ships.

11. SYDNEY approached KORMORAN slowly from astern on KORMORAN's starboard. SYDNEY was now visible to KORMORAN as a narrow silhouette.
12. At 1800H, KORMORAN sent a w/t signal on 600 metre wave-band "QQQ STRAAT MALAKKA 111° East 26° South". A w/t station repeated the message and requested further information if necessary.
13. At 1815H, SYDNEY was on KORMORAN's starboard beam, at a distance of 900 m. SYDNEY opened out to show her full silhouette to KORMORAN. SYDNEY's main gun turrets with their 6" guns were pointing at KORMORAN.
14. At 1825H, the propeller on SYDNEY's Walrus aeroplane stopped turning. SYDNEY sent a signal to KORMORAN "Hoist your secret call. Further delay can only make situation worse."
15. At 1830, KORMORAN's captain gave orders to strike the Dutch flag and fly the German war ensign. KORMORAN's captain gave the order "Remove disguise" and gave orders to his three weapons officers to fire. When these orders were given, KORMORAN's 15 cm, 2 cm and 37 mm guns were loaded and manned. SYDNEY dropped slightly astern of KORMORAN.
16. KORMORAN fired two torpedoes from her starboard deck-mounted torpedo battery. At the time she fired, she was running at 14 knots and the torpedoes were fired on an inclination of either 90 or 80. At the same time, KORMORAN altered her course to 260°. At the same time too, KORMORAN's guns fired at SYDNEY. The first shots fell short.
17. The range for the KORMORAN guns was raised 400 m. KORMORAN now fired a second salvo with guns nos. three, four and five. About 4 seconds later, hits from KORMORAN were noted on SYDNEY's bridge and her director control tower.
18. A full salvo was fired from SYDNEY at KORMORAN. No hits were sustained by KORMORAN.
19. At five second intervals, KORMORAN hit SYDNEY with two more salvos. The shells hit SYDNEY amidships, hitting the bridge and her aeroplane which caught fire. There was a bearing correction to the left for KORMORAN's 15 cm guns to fire at SYDNEY's forward turrets. KORMORAN's 20 mm cannon and her starboard 37 mm gun were being fired into SYDNEY's anti-aircraft guns, her torpedo battery and bridge.
20. After KORMORAN's fifth salvo, SYDNEY's "X" turret fired at KORMORAN with rapid and accurate fire. Shells from the X" turret hit KORMORAN's funnel. Shells destroyed one of KORMORAN's wireless rooms. Another shell pierced the plating forward of KORMORAN's bridge just above her main deck.

DSTO-GD-0559

21. SYDNEY's "Y" turret fired two or three salvos at KORMORAN. All shots fell wide.
22. SYDNEY's "A" and "B" turrets had been silenced.
23. At about the time KORMORAN fired her eighth and ninth salvos, her torpedo hit SYDNEY slightly ahead of her "A" turret. The second torpedo just missed SYDNEY's bow. SYDNEY's bow was almost entirely submerged after sustaining the torpedo hit.
24. While KORMORAN maintained her course at 260°, SYDNEY turned hard about. The roof of SYDNEY's "B" turret was seen to fall overboard.
25. At about 1835H, SYDNEY passed astern of KORMORAN. After she passed astern, SYDNEY's main turrets were observed to be pointing to port.
26. Dense smoke was emerging from KORMORAN's funnel from a fire in her engine room. Gunnery control was passed from KORMORAN's signal deck to the director control station at her stern. KORMORAN's No. 6 stern 15 cm gun began to fire at SYDNEY to a range of up to 4,000 m. SYDNEY's secondary guns were probably not manned.
27. At about 1845H, KORMORAN turned to port in order to destroy SYDNEY fully. Shortly afterwards, KORMORAN's engine revolutions fell rapidly. Communications were lost with the engine room.
28. KORMORAN held a course of 240°. Four torpedo tracks from SYDNEY may now have been seen passing astern of KORMORAN. There were severe vibrations through KORMORAN as her engines over-revved. A message was received at KORMORAN's bridge that her engines and all fire-fighting apparatus were out of action. An order was sent down by messenger to the engine room to try to get one engine working.
29. At about 1850H, gun control returned to KORMORAN's signal deck. All guns began firing at SYDNEY at a range of 6,000 m. SYDNEY was steering on a course taking her approximately south. She was sailing at a slow speed. SYDNEY's Forecastle was deep in the water. SYDNEY was on fire between her bridge and her after funnel. She received constant hits from KORMORAN.
30. At about 1900HRS, a single torpedo was fired at SYDNEY on inclination 110 at a speed of 5 knots while SYDNEY was 7,000 m away from KORMORAN. The torpedo missed astern.
31. At about 1925HRS, the order to cease fire was given on KORMORAN. The last range taken for SYDNEY was 9,000 m. The last shot was fired at a range of 10,400 m on a bearing of 225°. Some of KORMORAN's guns were by now inoperable, with barrels overheating. When her firing stopped, KORMORAN's 15cm guns had fired approximately 500 armour-piercing shells and fifty contact fuze shells in the direction of SYDNEY.



32. On KORMORAN an attempt was made to get into the engine room; the attempt failed. KORMORAN was on fire herself and with her fire-fighting apparatus not able to be used, orders were given to abandon ship. A watch was placed on the mine-deck. Boats and life-boat equipment which did not depend on electrical supply were lowered into the water. When the boats were lowered, the sea state was 3 to 4.
33. Viewed from KORMORAN, SYDNEY's outline was eventually lost in the twilight, at about 2000H. At roughly 16,000 m from KORMORAN, SYDNEY could no longer be seen from KORMORAN. Her course, at the time she ceased to be visible, was 150°. A large fire could be seen in her direction until about 2300H.
34. At about 2200H, all of KORMORAN's rescue equipment was in the water and had been cast-off. There were about 120 men left on KORMORAN, most of the officers, warrant officers and senior petty officers. The mine-store on KORMORAN began to fill with smoke. An order was given to launch the boats from the no. 1 hatch. Two boats were being winched out by hand, in an operation that took well over an hour, from KORMORAN's number 1 hatch. A torpedo was fired from KORMORAN's underwater torpedo tube.
35. At 0055, scuttling charges were laid in KORMORAN's port forward oil tank. Thick smoke filled the mine deck.
36. At 0100H, KORMORAN's ensign was hauled down and scuttling charges activated. KORMORAN's captain and mine-officer cast off from KORMORAN in the last boat. At 0110H, the scuttling charges blew up. There was a large explosion with debris falling around some of the KORMORAN survivors in life-rafts. At 0135H, KORMORAN sank rapidly by her stern.

## 6.2 List of Assumptions about the Disposition of the Crew at Action Stations [71]

Below is a list of assumptions you were instructed to make about the approximate distribution the crew of *Sydney* when at Action Stations (also known as First Degree of Readiness). Please note that the list does not purport to cover the entire crew nor every compartment in the ship. For instance, the location and number of engineering staff ("Stokers") is not the subject of detailed assumption. The assumptions are;

1. On the bridge, there were:
  - a. four officers (Captain, Navigator, Officer of the Watch, Assistant Officer of the watch);
  - b. four ratings (W/T ratings, runners and/or messengers);
  - c. seven signalmen (Chief Yeoman, Yeoman of the Watch, Leading Signalman and two signalmen on each bridge wing); and
  - d. three helmsmen and assistants.
2. In the Director Control Tower, there were:

DSTO-GD-0559

- a. In the front compartment (called “the Director”), four personnel: the Director Layer, the Inclinometer Setter, the Range to Elevation Unit Operator and the Director Trainer; and
  - b. In the rear compartment, four personnel: the Rate Officer, the Gunnery Officer, the Spotting Officer and “the phone number” (a person who manned the internal telephone).
3. In the High-angle Control Station there were four or five men.
4. On the flag deck, there were:
  - a. six to eight signalmen out on the deck; and
  - b. five to six signalmen.
5. At the Aft Control Position, there were three personnel.
6. Each of the three searchlight platforms were manned by two seamen.
7. In the each of the four turrets (gun houses), there were twenty men being:
  - a. The officer of the turret;
  - b. The PO of the turret;
  - c. The phone number;
  - d. Seven men operating each gun; and
  - e. Three men manning the Local Control Cabinet.
8. In respect of the supporting spaces for the 6” guns:
  - a. in each of the four 6” shell rooms, there were three to four men. These may have been members of the Supply or Miscellaneous Branch (stewards, cooks, bandsmen etc);
  - b. in both 6” magazines, there were four ratings; and
  - c. in each of the four cordite rooms, there were two to three men.
9. On the 4” gun deck, each of the four 4” guns was manned by seven men with a senior hand and an officer in charge of the gun deck.
10. Each of the two Torpedo mounts was manned by five torpedo men including two leading hands and a Petty Officer. An officer and Chief Petty Officer were in charge of the torpedo batteries.
11. Three Seamen manned each of the three 0.5 multiple machine gun mounts.
12. On the quarterdeck, three to four seamen manned the depth charges.
13. In the Aft (Emergency) Steering Compartment there were five seamen standing by the emergency steering gear.
14. In respect of the Walrus aircraft and catapult:
  - a. six RAAF personnel plus one RAN observer was formed up near the aircraft; and
  - b. five stokers were formed up ready to swing out the catapult.

DSTO-GD-0559

15. In the Lower Steering Position there were four men, being:
  - a. The Executive Officer; and
  - b. Three hands – a signaller, a W/T operator and a messenger.
16. In the wireless Rooms (Main Wireless Room, Second Wireless Room and Auxiliary Wireless Room, there were 25 members of the Communications Branch.
17. In addition to being in the supporting spaces for the 6” guns, members of the Miscellaneous Branch would be formed up as extra hands in sick bays, wireless rooms and power rooms.
18. The torpedo men (being electricians in the ship) who were not in one of the torpedo crews would be formed up at vital electrical equipment.
19. Stokers, in addition to being formed up in the engine rooms, boiler rooms, and at the aircraft catapult, would be formed up near other machinery such as pumps.
20. There were four civilian canteen staff.

## 7. Interpretation of Evidence

### 7.1 Introduction

This chapter of the report details how the evidence from the wreck site of *Sydney* has been interpreted. This interpretation uses not only the factual evidence from the wreck but also considers evidence from similar events to other ships. More importantly, advanced analysis techniques have been used to determine the effects of the weapons damage on *Sydney* and naval architectural assessments have been made to determine the probable final demise of *Sydney*. This section of the report follows the events in chronological order. The events during the battle are described initially following the torpedo damage and weapons effects on the port side, then during the second phase of the battle when *Sydney* turned. A section describing the likely situation onboard after the point of disengagement takes the reader through to the final sinking and a possible explanation of the collapse of *Sydney* is proposed. Finally an analysis of the search for *Sydney* is discussed which indicates the reasons why no survivors were found.

#### 7.1.1 Weapons Effects

##### 7.1.1.1.1 Weapon Damage Analysis Process

The damage survey of the wreck site, detailed in Appendix A, positively identified 88 15 cm shell hits striking *Sydney*. A number of these shell hits may be the result of the same weapon ricocheting between two hit points, however the number of hits identified from the wreckage has been used as the minimum baseline of the damage that the 15 cm shell hits inflicted on *Sydney*.

It is probable that numerous unidentified hits are likely to have occurred on *Sydney*. These are unable to be identified due to the state of the wreckage. This can be tempered by the fact that the shells identified as clearly penetrating the hull may have not detonated.

Hits which have failed to penetrate or breach the hull were ignored for the XVAM analysis, although fragments from these shells would certainly be a threat to crew and boats near the areas of these hits, especially to any crew members in the water at the time of the hit.

The XVAM simulation was used to predict the spread of fragment and blast damage throughout *Sydney* based on the observed 15 cm shell hits. Further damage was then estimated from the smaller calibre weapons and applied to the overall damage.

The actual detonation locations of the shells penetrating into the ship cannot be determined from the evidence obtained from the damage survey. The detonation location for shells identified as AP rounds were based on detonation occurring on the centre line of the ship, unless obvious structure in the line of fire prevented this.

The ricochet of the shells and fragments within the internal structure which is known to occur were ignored for this analysis. For the purpose of this analysis, no benefit would be gained due to the number and spread of shell hits.

#### 7.1.1.1.2 High Explosive (HE) shell damage mechanisms

The primary damage mechanisms resulting from the detonation of HE naval fragmenting rounds is due to penetration of fragments into the surrounding structure and the loading on the structure from blast overpressure. For large shells significant damage results from the shell itself as it penetrates the structure and creates a fragment field of debris along its path. Fragments which are super heated will also be a source of fire if they lodge into flammable material. The proportion of damage resulting from each mechanism will depend on the fuzing and type of shell.

Structural damage will include the blowing out of non-strengthened partition doors at low overpressures and the jamming of heavier dogged doors into their door frames. Non-strengthened compartment partition bulkheads which are generally riveted onto a frame, will be dislodged into passageways making access throughout the ship for damage control crews or evacuating extremely difficult and time consuming.

There were two types of 15 cm shells *Kormoran* possibly fired at *Sydney*. These were the nose or base fused 15 cm HE shell and the base fused AP shell. Both shells had masses of approximately 45.3 kg and a striking velocity of 670 m/s over a range of 5000 m. This large momentum of the shell had significant destructive power even if the shell failed to detonate.

The damage mechanisms involved for a functional shell are described below.

Nose fused HE shells are designed to detonate on contact with significant ship structure (the shell will pass through weaker structure without the fuze activating, On detonation a large spray of an estimated 4000 fragments will be generated at velocities of 1200 m/s. For the German shells of the WWII, the ratio of the mass of the shell casing to explosive was in the range of 10:1, which limits the damage resulting from the blast overpressure from the exploding shell. However human casualties from injuries resulting from the explosion will occur within an estimated five metre radius of the detonation.

For base fused AP shells, the shell is designed to penetrate armour material and has a base fuze with a delay. The penetrating power of the shell depends on both the striking velocity of the shell and the angle that the shell has contacted the plating. For a hit perpendicular to the target, the shell entry hole will be close to the shell diameter of 15 cm. A spray of secondary fragments will be generated in front of the weapon as it penetrates through the ship.

The distance the shell enters into the ship is dependent on the internal structure of the ship that the shell hits and the fuze delay. The AP shell is a thick walled projectile with approximately 1 kg of explosive. The blast overpressure generated from this shell will have a limited damage potential, but the explosion will produce more than two thousand lethal fragments. The fragments will have high velocities due to the velocity from the detonation plus the residual velocity of the warhead prior to detonation.

#### 7.1.1.1.3 Small arms fire damage mechanisms

*Kormoran* was armed with 20 mm and 3.7 cm guns each capable of firing a variety of projectiles and warheads, although the actual number of rounds that were fired or

DSTO-GD-0559

actually hit *Sydney* from these guns cannot be determined. The rate of fire of these guns was 80 rounds per minute (rpm) for the 3.7 cm gun and a conservative 120 rpm for the 20 mm gun which would have meant that a large number of steel penetrators and fragments from these weapons would have been scattered widely about *Sydney*.

The 3.7 cm gun was capable of firing 0.7 kg AP or 0.65 kg HE shells at velocities of 800 m/s. The mechanisms for fragment damage are similar to the 15 cm shell description above, with damage occurring from the impact of the weapon on the target and further damage due to the detonation and fragmentation of the round.

The 20 mm gun was capable of firing a range of shells, with a mass of 120 g and a velocity of 900 m/s, at a rate of at least 120 rpm. As with other HE shells the lethality of the penetrator is enhanced due to the HE charge being detonated on impact with the target. It is considered that most of these penetrators would have been AP rounds.

#### 7.1.1.1.4 Description of 15 cm shells used in analysis

The 15 cm German shells used for the XVAM analysis are shown in Figure 201 and Figure 202. It is important to note the extremely heavy steel nose of the AP round and the relatively thick walled section of the warhead; the comparatively thick walls of the shell lead to larger and heavier fragments compared to the typical thinner walled HE shell shown in Figure 202.

Note the cross sectional view of the 15 cm shell shown in Figure 202 is a representative profile of the shell possibly used by Kormoran, but is used to illustrate the relative difference in shell designs.

The nose fused shell had a casing weight of close to 41kgs, which would have generated over 4000 steel fragments.

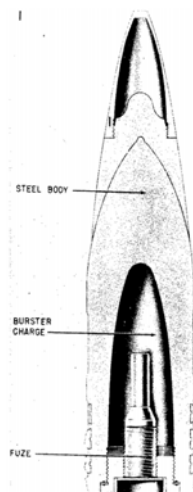

Figure 201: Cross sectional profile of a German 15cm A.P. Projectile Sprgr. L/37 [284]

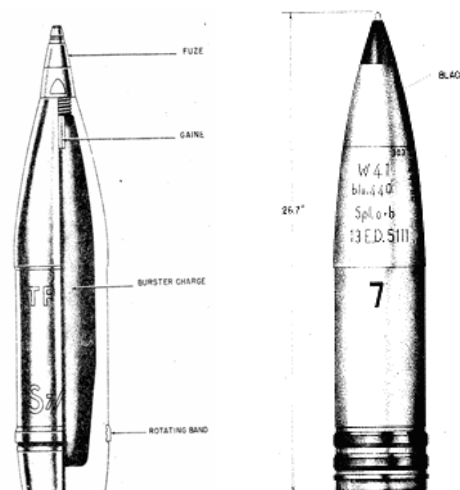

Figure 202: Cross sectional profile of 15 cm HE German projectile, nose fuze: 15 cm Spgr. L/4,4 Kz (m.Hb) [284]

#### 7.1.1.1.5 Weapon Trajectories

The 15 cm German guns fired the shells with a high muzzle velocity designed to be propelled over 25000 m. Table 21 provides range and elevation for a 15 cm naval shell. It is evident from the data that engagements at distances of 5000 m only require a gun elevation of  $1.7^\circ$  to achieve a hit that is close to flush with the target surface. Guns elevated at any significant angle close to the target would result in the shell passing over the target.

Many of the shots on *Sydney* hull appear to have a shallow impact angle; however it is impossible to measure with any accuracy the actual impact angle from the photographs of *Sydney*. The actual impact angle is also complicated by the hull shape which is not a perfectly vertical surface and any angle of attack between the two vessels adds to the challenge of measuring the fall angle. It can only be observed that the shots on the hull would unlikely to be from a fall angle of anymore than  $10^\circ$  as this would cause the shell to ricochet off the hull.

Table 21 also provides data on the striking velocities at a set range, the lethality of the warhead is high over all ranges and the shells are extremely lethal over 10000m with a striking velocity of 445m/s. This velocity would enable the shell to penetrate a large section of hull structure.

DSTO-GD-0559

Table 21: Range and elevation of 15 cm shell [69]

| Elevation | Range with 45.5 kg AP Shell | Striking Velocity | Angle of Fall |
|-----------|-----------------------------|-------------------|---------------|
| 1.7°      | 5,000 m                     | 673 m/s           | 2.2°          |
| 5.3°      | 10,000 m                    | 445 m/s           | 8.8°          |
| 11.5°     | 15,000 m                    | 318 m/s           | 23.5°         |
| 21.4°     | 20,000 m                    | 314 m/s           | 42.0°         |
| 36.3°     | 25,000 m                    | 332 m/s           | 59.5°         |

#### 7.1.1.1.6 Extent of damage

Based on the shell designs, weight of explosive charge and casing material, damage contours for these shells have been developed [285]. The estimated damage contours are shown in Figure 203 and Figure 204. As is typical for HE shells the majority of fragments are driven outwards in a main beam spray from the detonation point in a zone of 50° to 120° from the warhead nose. Fewer, larger fragments will be thrown forward and back, especially for the AP shell which will propel a very large fragment forward.

The fragments generated by the debris field as the weapon smashes its way through the ship, are not accounted for in XVAM analysis. They are, however, applied at a later step.

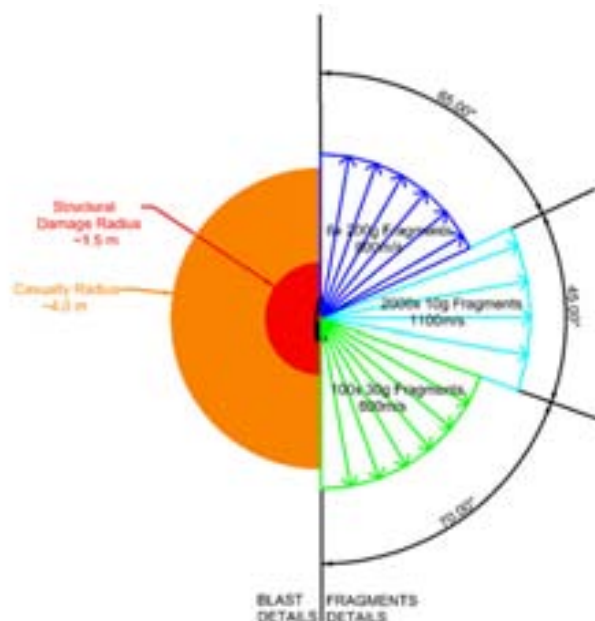

Figure 203: Estimated blast and fragment damage contours for a stationary 15 cm AP weapon detonation.



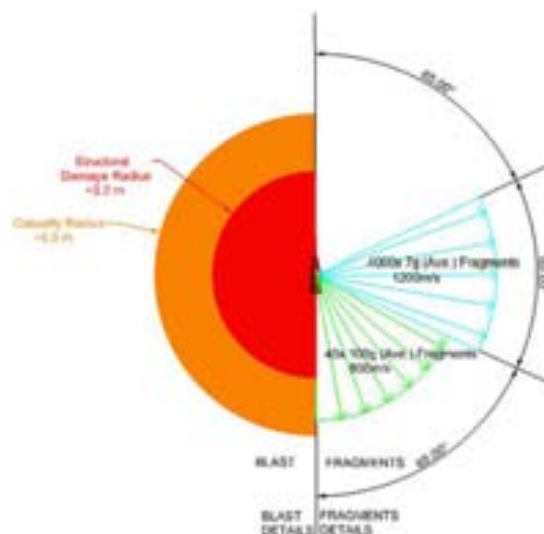

Figure 204: Estimated blast and fragment damage contours for a stationary nosed fused 15 cm HE shell detonation

## 7.2 Port side engagement

From the assumptions provided, during the first five minutes of the engagement Sydney was hit on the port side, in close proximity, by a large number of 15 cm, 3.7 cm and 20 mm shells. In this period Sydney also received a direct hit by a torpedo forward of A turret. Sydney returned fire, but no detailed analysis of the effects have been included in this report.

### 7.2.1 Torpedo Damage

Observations made from the ROV footage show extensive physical damage to the bow of Sydney. This damage is detailed in Chapter 6, which shows the location and extent of the damage to the hull Figure 115, Figure 116 and Figure 124, indicating a single contact-detonated torpedo hit.

#### 7.2.1.1.1 Torpedo Damage Mechanisms

An underwater explosion on contact with a ship's hull or in close proximity to a ship will generate a number of physical effects on the ship, which will result in various degrees of damage to the ship structure and ship systems. It is important to note that the extent of damage and the damaging mechanisms will change with weapon stand-off.

German torpedoes in 1941 were contact fused weapons. The primary weapon damage mechanism when a torpedo detonates on contact with a ship is the explosion which will tear a hole in the hull. The size of this hole will be dependent on the net explosive weight of the torpedo and the strength and design of the hull in the vicinity of the torpedo detonation. The rupture of the bulkheads in the vicinity of the detonation can

DSTO-GD-0559

result from either the direct exposure to the explosion forces, or the result of the deformation caused by the deformation of the hull or bulkheads in the vicinity of the explosion.

Further damage will result from the penetration of fragments generated as a result of the exploding weapon and also of the structure immediately adjacent to the detonation point. This fragmentation adds further to the internal damage of ship systems and structure directly in the vicinity of the explosion. Structural damage from a contact explosion is generally limited to the immediate area of the explosion.

A secondary damage mechanism is dependent on the depth of the explosion below the waterline. An underwater explosion generates a large gas bubble from the explosive reaction products. The bubble for a 280 kg explosive torpedo could have a radius approximately 9.8 m radius. This large bubble displaces a large volume of water. On the collapse of the bubble water is forced into the hole generated from the explosion. For shallow explosions a lot of the gases are lost to the atmosphere or into the hole generated by the explosion. As the bubble breaks the surface a large plume of water is thrown into the air.

The consequences are that flooding will rapidly spread to compartments adjacent the hole.

The final damage mechanism from the torpedo explosion is the initial heave the ship will receive upwards. The shock wave from the explosion will generate a shock loading throughout the ship, which can result in damage to vital components including crew throughout the whole ship. However little or no whipping of the structure will occur.

#### 7.2.1.1.2 Examples of Torpedo Damage

Examples of several British Cruisers from the same era that were hit by torpedoes are listed in Table 22. Although of different classes, the WWII British cruisers all have similar layouts, including *Sydney*. All these ships returned to port without sinking. However, these were single impact events where crew could concentrate on recovering the ship's functions, rather than a constant barrage at close quarters. This involved repairing communications, electrical systems and engines; and responding to flooding and fire fighting.

Table 22: Examples of WWII Cruisers that survived torpedo impacts

| Ship   | Dimensions  | Hit location  | Immediate Systems Damage   |
|--|---|---|--|
| HMS Arethusa<br>Cruiser, completed 1935.<br>Hit Nov. 1942                              | Length 506'<br>Beam 51'<br>Draught 17'<br>Displace 7180 tons  | Bulkhead 20 to 61 flooded to waterline (Port side, below B Turret)                          | <i>Engines</i><br>All working, Lower Steering Flooded<br><i>Comms</i><br>Main W/T undamaged, 2ndry & auxiliary W/T flood damaged   |
| HMS Birmingham<br>Southampton Class<br>Cruiser, completed 1940<br>Hit Nov. 1943 [144]  | Length 591'<br>Beam 64'<br>Draught 21'<br>Displace 12190 tons | Torpedo explosion below Bulkheads 22- 25<br>Flooding fwd Bulkhead 65                        | <i>Electrical</i><br>Out at Bow, emergency lighting rigged Breaker rooms 1&2 (fwd) fuses blown; Ringmain sectioned into 4<br><i>Engines</i> Machinery and auxiliary rooms unaffected;<br><i>Comms</i> Collapse of Main aerial legs/ jury rigged, sound equipment, warning telephones and radar flooded |
| HMS Liverpool<br>Southampton Class<br>Cruiser, completed 1938<br>Hit Dec. 1940 [286]   | Length 591'<br>Beam 64'<br>Draught 20'<br>Displace 11650 tons | Fwd of 30 severe damage, aviation fume exploded-blew top off turret, fwd of 41, fire ensued | <i>Electrical</i><br>Main Switch Room OK, fwd only<br><i>Engines</i><br>OK   |
| HMS Liverpool<br>Southampton<br>completed 1938 Class<br>Cruiser<br>Hit June 1942 [286] | Length 591'<br>Beam 64'<br>Draught 20'<br>Displace 11650 tons | Stbd of aft engine  | <i>Engines</i><br>Aft engine/boiler flooding, stbd props out, steering jammed<br><i>Comms</i> radar, HACS, W/T aerial out  |
| HMAS Hobart<br>Modified Leander<br>Class Cruiser,<br>completed 1936<br>Hit Nov. 1943   | Length 562'<br>Beam 56'<br>Draught 16'<br>Displace 7195 tons  | Aft   | <i>Comms</i> 3 aft receiving aerials   |

### 7.2.1.2 Flooding Consequence of Torpedo damage

A static (calm water) stability analysis was undertaken to determine if the damage resulting from the torpedo strike would have resulted in the loss of *Sydney*. A series of analysis was undertaken whereby the extent of flooding due to the torpedo strike was gradually increased. It was assumed that all internal compartments were damaged, resulting in flooding of the entire watertight section. This assumption is based on the



Table 23: Forward and Aft draughts resulting from torpedo damage

| Sections Damaged | Approx. Distance from FP (m) | Draught at aft perpendicular $T_{AP}$ (m) | Draught at forward perpendicular $T_{FP}$ (m) |
|------------------|------------------------------|---|---|
| Intact           | -                            | 5.56                                      | 4.05  |
| FP – Frame 14    | 12.80                        | 5.46                                      | 4.24  |
| FP – Frame 19    | 17.37                        | 5.39                                      | 4.38  |
| FP – Frame 25    | 22.86                        | 5.24                                      | 4.68  |
| FP – Frame 35    | 32.00                        | 4.98                                      | 5.26  |
| FP – Frame 53    | 48.46                        | 4.22                                      | 7.01  |

Figure 206 shows in blue the region of potential flooding when the damage is from the forward perpendicular to Frame 53. (although this region will only flood up to the flooded waterline) Frame 53 is considered to be the location of the first intact watertight bulkhead aft of where the torpedo hit.

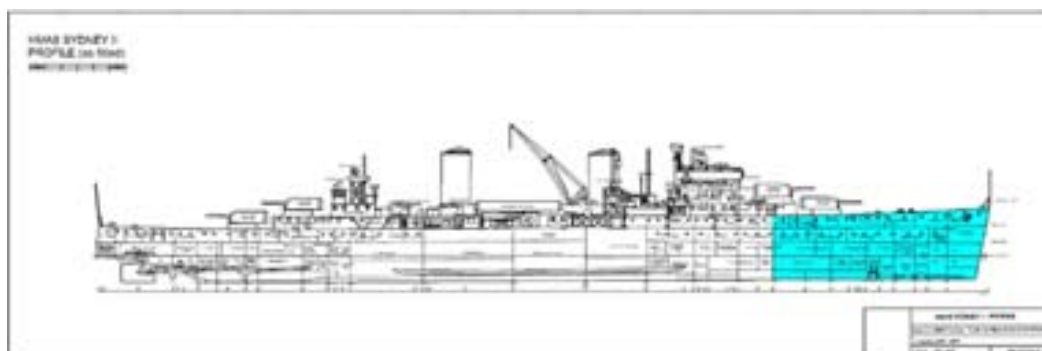

Figure 206: Potential flooding extent resulting from the torpedo strike

Figure 207 shows a visualisation of the intact *Sydney* in calm water. Figure 208 shows the changes to the trim of the vessel after flooding has occurred between the forward perpendicular and Frame 53. It is evident that although there is an increase in the sinkage and trim of the vessel there is still sufficient buoyancy and freeboard which enables her to remain afloat.

Figure 207: Intact *Sydney* in calm water

DSTO-GD-0559



Figure 208: *Sydney* in calm water after sustaining damage due to torpedo hit. Note the reduced height from the tip of the bow to the waterline

### 7.2.2 Shell Damage

The German survivors account of the battle between *Kormoran* and *Sydney* started with *Sydney*'s port side exposed to *Kormoran* [149]. Within five minutes *Sydney* turned to port which allowed *Sydney* to steam aft of *Kormoran* and exposed the starboard side of *Sydney* to *Kormoran*'s guns. The damage to the port side of the ship will therefore be considered first, but it should be highlighted that the following description of the damage is in no particular temporal order. While the German survivors give some detail of the order in which the damage was sustained, the order of the actual damage will never be known.

It should be noted that the source of the damage sustained by the contact fused shells is obvious from the observed photographs, while the damage due to shells penetrating the ship is not so obvious. Many of the shells in WWII failed to detonate and it is therefore difficult to determine if the penetrating shells are due to the AP shells that would have been used, or whether they were contact fused shells that did not detonate. In either case, the effect of a 45 kg shell penetrating the structure will still cause significant damage, even if it failed to detonate.

The location of the port side 15 cm hits to *Sydney* are shown in Figure 125 to Figure 128. These hits are primarily concentrated around the forward part of the ship, superstructures, and the upper and Lower Decks below the forward superstructure. Another concentration of hits is midships in the region of the catapult. All these shell hits are shown in Figure 209.

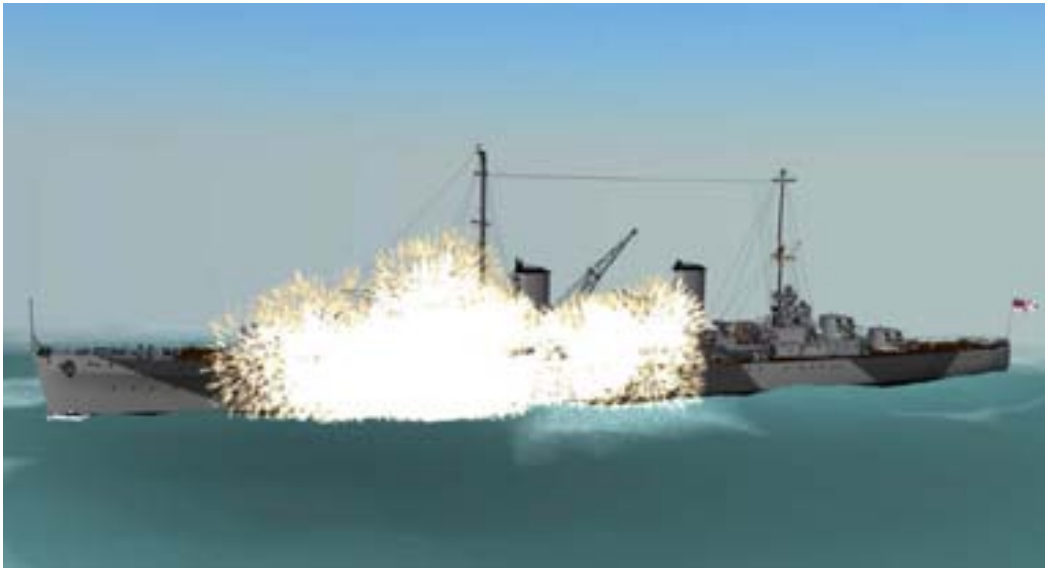

Figure 209: Shell detonations on the port side of Sydney occurring simultaneously

The bridge area of *Sydney* received multiple hits on the port side. Two of the most significant weapons hits in this area were to the Director Control Tower (DCT) and the High Angle Control Station (HACS). The damage to the base of the DCT is shown in Figure 210. This is a likely to have been caused by the detonation of a 15 cm shell fired by *Kormoran* and is likely to have put the DCT out of commission for the rest of the battle. Figure 211 shows a reconstruction of the DCT as it was attached to the bridge so that the original configuration of the ship in this area can be understood. It should be noted that the DCT is not likely to have been removed from its mountings by the damage received and that the DCT is likely to have separated from its mounting as a result of the sinking. All crew in the DCT would have sustained injuries from the weapons damage.

The HACS also received a very significant hit on the tower support, as shown in Figure 212. The original configuration of the HACS is shown in Figure 213, and shows that there was a considerable structure above where the HACS has broken off after the shell damage. Examination of the damage to the support and damage to the surrounding structure has led to the conclusion that this hit came in from the port side and led to the HACS buckling over towards the starboard side of the ship. The damage to these two structures would have left *Sydney* with seriously diminished fire control capabilities.

DSTO-GD-0559



*Figure 210: Damage to DCT support [288]*



*Figure 211: Representative diagram of DCT before damage*





Figure 212: High Angle Control Station support [289]

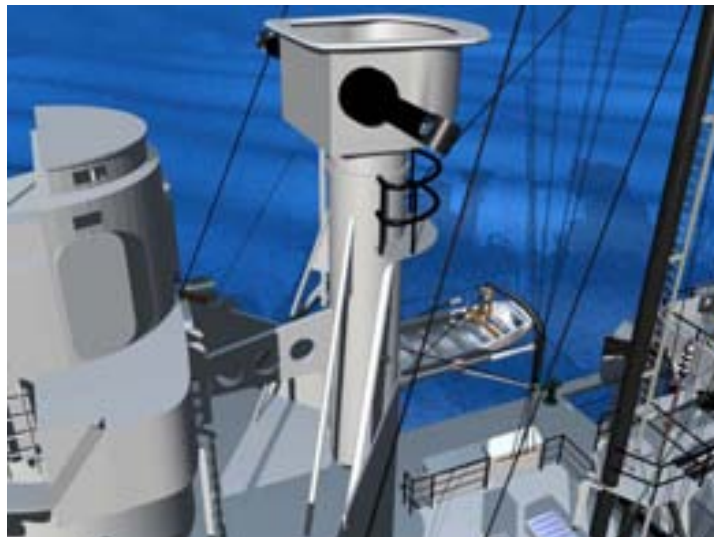

Figure 213: Representative diagram of the HACS prior to damage

Other hits have been identified into the bridge area and there is likely to be more shell hits than have been identified. However due to the severe damage to the superstructure in this area due to fire and sinking damage, and the build up of corrosion and silt it has not been possible to identify any other weapons damage with certainty. German survivors report that the 3.7 cm gun was trained on the bridge area [290]. This gun fired 0.7 kg shells and would have resulted in additional damage to this area, which may not be obvious from the ROV footage.

Moving forward of the bridge there are two significant points of damage on B Turret (Figure 214) that are evident from the port side. The hit between the barrels of B Turret indicates that the shell did not fully penetrate the armour plate as the hole is less than 15 cm in diameter. However, lack of fragment damage around this hole indicates that the shell may not have exploded at this location; it either failed to explode or the damage at the base of B Turret may be the result of the shell falling down onto the deck from this

DSTO-GD-0559

shot. Another significant observation is the missing roof section on B Turret which may have been thrown off the turret due to the shock of the shell hitting the armour plating. The hit between the barrels shows that this turret was aimed at *Kormoran* at the time of the hit. It is likely that damage to the turret base jammed the turret mechanism.



Figure 214: Hits to B Turret [291]

The hull under B Turret has also received a number of hits and there is evidence that multiple shells have penetrated the upper and Lower Mess areas on the port side. One significant region of damage has breached the water tight bulkhead between No. 3 and No. 2 Lower Mess's, as shown in Figure 221. This damage is likely to have been caused by a contact detonating shell. There are also numerous holes from shells that have penetrated the hull (for example Figure 222). These shells are likely to have been AP shells and although the damage on the hull appears non-lethal, the internal detonation of these shells would have caused significant internal damage to structures, equipment and crew and had a major effect on the function of the ship. These hits would have had a major effect on the damage control effort in controlling damage from the torpedo hit. As DC1 was based in this location heavy casualties would have occurred from these hits.

Section 6 shows the weapons damage to port and starboard sides of *Sydney* and shows that there would have been a significant number of fragments produced in the vicinity of the ship's boats and floats. The Pinnacle is relatively intact but does show fragment damage. The Whaler shows a large hole on both the port and starboard side. Interestingly, the weapons damage in Figure 217 shows damage located on the port side to the Shipwrights Workshop. This damage is highly unlikely to have occurred without the shell striking the Whaler and Figure 217 shows such damage to the Whaler in a very appropriate location. This shell hit is shown in Appendix 1 as P2FB39. Recreation of the shell hit has been attempted in Figure 218 which shows the very shallow angle of the trajectory consistent with the close range of the overall engagement.

Figure 215 also shows extensive shell damage to the bakery which would have resulted in extensive fragment damage to the surrounding area which includes the port side Pinnacle and the two Carley floats.



Figure 215: Damage to port side of Bakery [292]



Figure 216: Reconstruction of midships around the Bakery

DSTO-GD-0559

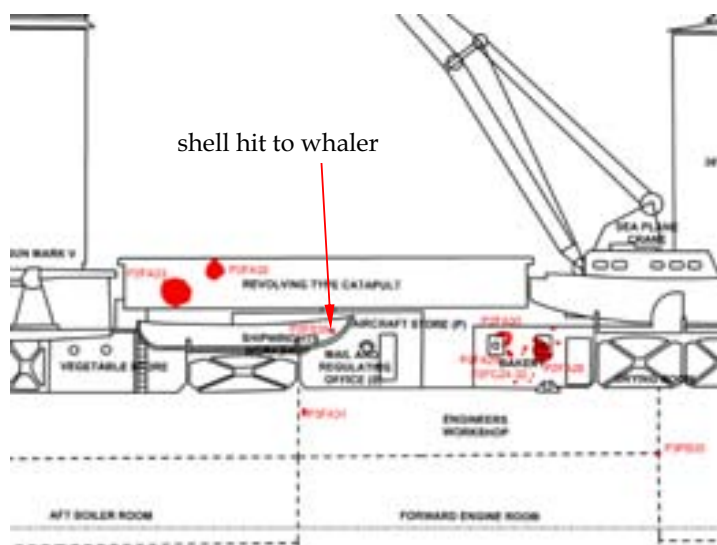

Figure 217: Diagram showing weapons impacts on the port side amidships

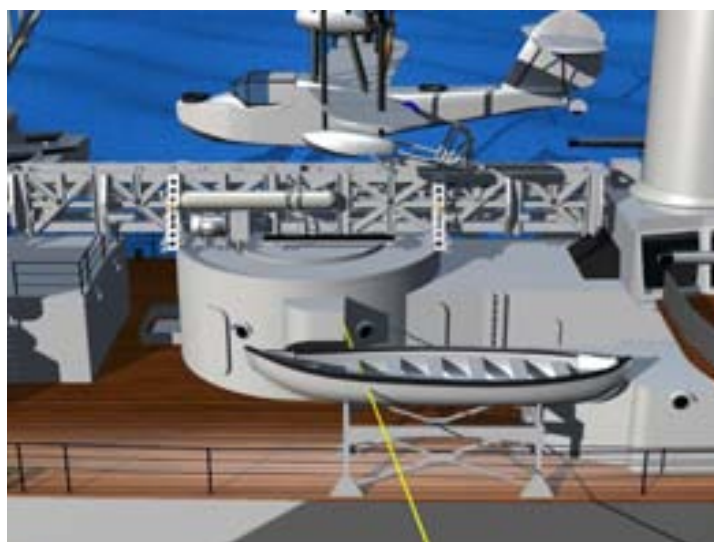

Figure 218: Visualisation of the shell trajectory to cause damage to the port side Whaler

The port side Whaler also shows evidence of fire damage possibly due to fire nearby.

The boats cradles showed varying degrees of fragment and weapon damage. The shell and fragment damage to several of the boat cradles suggests that the boats may also have been damaged to such a degree to make them un-useable for evacuation. There is evidence of fire damage to some of the surrounding superstructure close to the boats.



Figure 219: Contact detonation around the 32' Cutter davits [293]



Figure 220: Reconstruction of 32' Cutter

The shells which detonated on contact would have generated a large number of fragments. The hit to the area surrounding the davits supporting the 32' Cutter, shown in Figure 219, are likely to have caused significant damage to this boat. Although the collateral damage may not be obvious from the ROV footage, when considering a reconstruction of the ship in this region (as shown in Figure 220), the potential for fragment damage to the 32' Cutter and surrounding structure is obvious.

The davits for the Cutter are missing and were most likely damaged/ destroyed during the engagement. They are located slightly aft of the bridge and this was where extensive weapons damage is seen. It is highly likely that the Cutter was also possibly blown or fell into the water during the engagement. Whilst at sea the Cutter was swung outboard on the davits. If the davits were damaged the boat would not have fallen onto the deck but into the ocean. Thus, it is not likely that any remains of the Cutter would be found in the debris field but more likely at the location of the engagement.

DSTO-GD-0559



Figure 221: Example of contact detonating shell [294]



Figure 222: Example of AP shells [295]

The bakery also shows evidence of significant damage on the port side due to both shell hits and fragments (see Figure 215). The sea-plane catapult has also received two shells hits that would have sprayed hot fragments over the aircraft and surrounding structure. Again, the potential for collateral damage is not evident until considering a reconstruction of this area of the ship as in Figure 216.

While there are hits to the bakery and catapult, the majority of the identified hits appear to be centred on the bridge and A turret, with a large number of shells penetrating the hull under these structures.

A hit to the engineering workspace would have further affected damage control capability with damage to DC2.

### 7.2.3 Fire Damage

Multiple fires on *Sydney* were likely to have been ignited from the effects of shellfire in the first five minutes of the engagement. The explosion of incoming warheads is capable of producing hot fragments which could ignite combustible materials. This would have led to the observed fire damage shown in the forward superstructure as well as the fire around the catapult in Chapter 6 (Figure 146). The fires in the forward superstructure would have been initiated as multiple small fires, due to the flammability of material, including the paint, on the superstructure. These fires would have eventually joined to form a larger conflagration. The fire near the catapult was probably caused by the ignition of aviation fuel. It would have rapidly developed into a large fire. One of the consequences was that smoke would have been drawn into the ventilation shafts below the upper deck into the aft machinery spaces within the first five minutes.

Fire insulation was not fitted to *Sydney*, and the method of slowing fire spread through steel decks and bulkheads would be to cool them using fire hoses.

#### 7.2.3.1.1 Smoke and Toxic Gas

Fires and gases from weapon detonation on *Sydney* would have produced smoke which caused problems with visibility as well as irritation and breathing problems for the crew. A number of toxic chemicals are likely to have been produced by the fires on the ship, and be present within the smoke. The toxicity of smoke can be illustrated by carbon monoxide (CO), one of the compounds produced in fires. Incapacitation occurs when carbon monoxide is present at high concentrations. A particular dose of carbon monoxide is required for incapacitation, and take up of carbon monoxide is cumulative. An increase in breathing rate is caused by presence of carbon dioxide (CO<sub>2</sub>), another compound produced in fires, which can reduce the time to incapacitation [36].

The predicted times for incapacitation for a 70 kg man at three levels of physical activity in concentrations of carbon monoxide are shown in Figure 223. The curve marked 'A' is for a person at rest, 'B' is for a person undertaking light work such as walking at 6.4 km/h, and 'C' is for a person undertaking heavy work such as running at 8.5 km/h [296].

DSTO-GD-0559

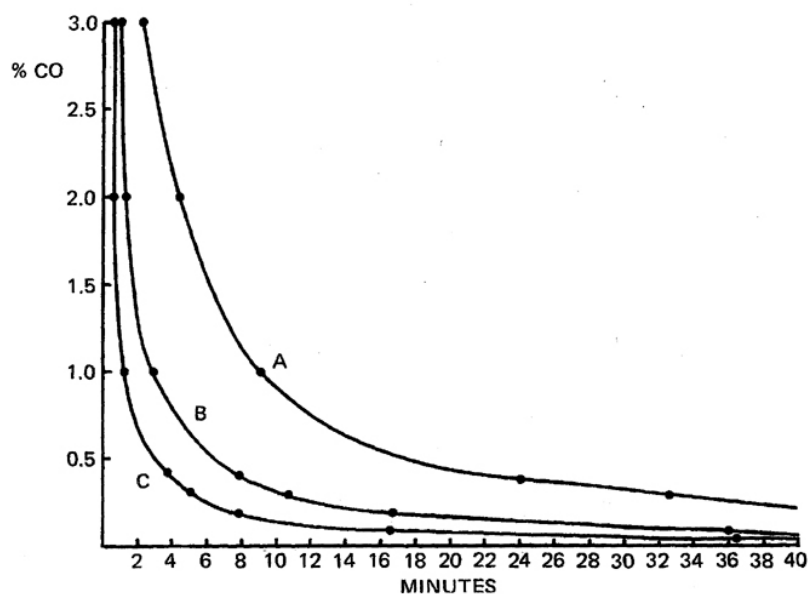

Figure 223: Time to Incapacitation by carbon monoxide for a 70 kg man at different levels of activity [296]

As an example of the levels of carbon monoxide produced in a fire, the smoke, heat, and gases produced by an armchair burning placed in a 39 m<sup>3</sup> room with an open doorway are shown in Figure 224. The measurements are taken in the doorway at a height of 2.1 m [296]. While the carbon monoxide concentration at the top of the doorway would be greater than those lower in the room, it is an indication of gases produced in fires.

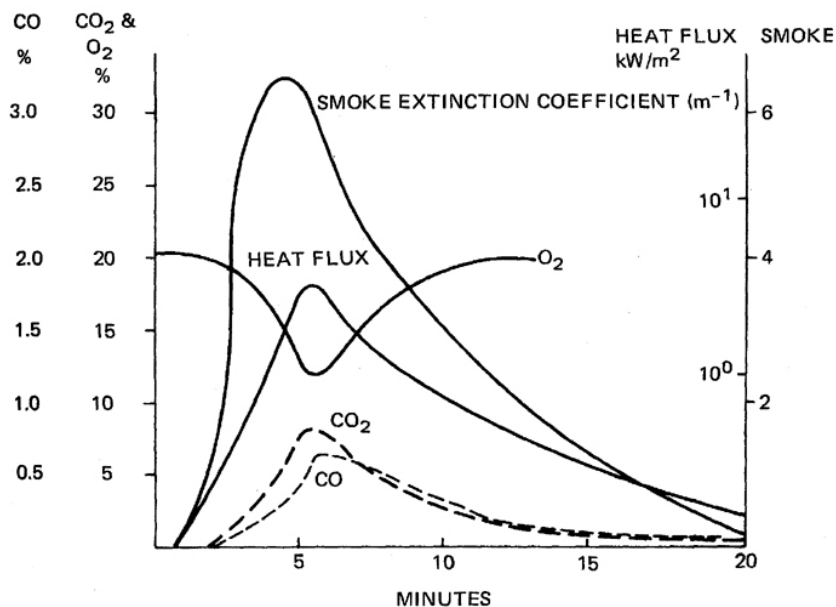

Figure 224: Smoke, heat, and gases produced by a burning armchair [296]



During a discussion of alteration and additions to *Sydney*, it was noted that under gas attack (taken as being chemical warfare attack) that a high concentration of gas was reached quickly in the forward boiler room and forward engine room, and that gas concentration rose more slowly in the aft boiler room and aft engine room [297]. Smoke from fires forward of the machinery spaces, such as the bridge superstructure, could be drawn into the forward machinery spaces in a similar manner, due to the location of the air intake vents for these spaces.

Ventilation could be closed to machinery spaces (boiler rooms or engine rooms). However, equipment in these spaces would need to be shut down. This is because air circulation provides cooling for these spaces and boilers require an air supply for the burning of fuel.

For other parts of the ship, the ventilation could be stopped by switching off electrical power to the fans. Alternatively, the ventilation ports could be closed from inside the ship, and valves within the ventilation trunking could be turned to provide air circulation within the ship [98].

Breathing apparatus were known to be used on British ships and Australian ships [47] during WWII. One type used was the Salvus apparatus [45, 298], shown in Figure 225.



Figure 225: *Salvus* breathing apparatus (HMAS Australia, 1943) [299]

#### 7.2.4 Casualties

Given the number of shells fired on *Sydney* and the consequential fires produced it is highly likely that crew members in many parts of the ship would have been enveloped by both smoke and toxic gases in the first five minutes of the encounter. The forward fire in the Bridge structure would have been initiated by *Kormoran*'s early salvos to the

DSTO-GD-0559

DCT and bridge by both the 15 cm and 3.7 cm shells. Most of the command centre personnel on the Bridge would have been incapacitated. The total number of crew affected would have been of the order of 60, including those on the Flag deck (signal area aft of HACS Tower) and Searchlight platform areas.

The damage caused by the shells penetrating the upper and Lower Deck areas would have included the incapacitation of crew as well as damage to the bulkhead at Frame 53 above the waterline. Number 2 Lower Mess was used as the Damage Control Station 1. This area contained between 30 to 50 men who would have been waiting for damage reports before disbursing on patrol. Other shells caused damage to, and casualties in, the Lower Steering Position on the Platform deck.

The continuous barrage of shells and smaller calibre weapons on the upper deck, would have incapacitated the crew on the open decks of Sydney. The port torpedo area would have been under heavy fire to prevent the discharge of a torpedo. All the life boats in this area would also have been raked with shrapnel, some of which can be seen in the earlier Figures in Chapter 6 of this Report. The A turret received a hit that would have severely impaired the 20 crew operating it and probably caused casualties down in the Ammunition lobby below on the Lower deck.

The number of crew on the open decks, Aft Control Tower and Bridge decks number about 170. Of these, only the crew on the quarterdeck at the depth charges, the Aft Control Tower and the 'X' and 'Y' turrets could be considered as unaffected by the engagement during the first five minutes.

When the torpedo impacted, the shock to the ship would have caused many more casualties in the forward section, including the crew in the 6" Magazines in the Hold, and would have flooded the 'A' shell room. The forward magazine compartments contained about 11 crew members, and survivors would have had difficulty in evacuating, as access through the deck areas above would be obstructed due to shell damage and fires. The compartments forward of the torpedo hit are unlikely to have contained crew.

The section between bulkheads located at Frames 64 and 76, (Switchboard Rooms, Lower Steering Position, HAC Calc Room, Aux. W/T and Telephone exchange) which was heavily populated, would have felt the shock of the torpedo. Although casualties here would have been low, damage to sensitive equipment would be expected (see Electrical discussion). The torpedo impact shock may have caused damage to or the collapse of the W/T aerial structure.

### 7.3 Possible movement of Executive Officer (XO)

The XO would be based at the Lower Steering Position in which Damage Control Head Quarters (D.C.H.Q.) was located at action stations [134]. This separated the XO from other senior officers on the Bridge, and in the case of weapon damage to that location; the XO was able to assume command. In this case the XO would probably move to the After Control Position to command the ship. There were several possible routes for the XO to take from D.C.H.Q. to the After Control Position. It was assumed that the XO avoided the open deck on the port side of the ship as this was under fire. Four routes were selected as possibilities, and each is detailed in the following sections.

The XO would have had a limited period of time in which to initiate his move from the Lower Steering Position to the After Control Position. This would be following damage to the Bridge and probable loss of command of the ship, and prior to further damage to the ship in the region of the Lower Steering Position.

The time taken for each route has been calculated based on measurements of crew movement times on HMAS Derwent in 1998 [300]. The measurements included; walking speeds, time to move up ladders, times to move through doors, and times to move through hatches. The following assumptions have been made:

- The XO walked (that is, he did not run)
- No obstructions were caused by other personnel or damage
- All doors and hatches were closed with dogs (clips) engaged prior to the XO arriving
- The XO secured all doors and hatches behind him
- Doors, hatches and ladders were of similar construction to those used in the measurement of crew movement times

#### 7.3.1 Route 1

Route 1 is illustrated in Figure 226. From the platform deck the XO was limited by one possible route to the Lower Deck, from the Lower Steering Position to the Lobby and up the ladder through the hatch to No. 4 Lower Mess.

The XO moved along Lower Deck through No. 4 Lower Mess, Stokers' Mess, Kit Locker Flat, Engineers' Workshop, starboard passage, to Fore Cabin Flat. The ladder was taken to the upper Deck outside the Torpedo Parting Space & Gyro Adjusting Room. The XO then moved along the deck and up the ladder outside of the Captain's Pantry. The XO moved up the ladder on the starboard side of the Forecastle deck structure to the aft superstructure deck. He then moved across the deck and into the After Control Position.

The time to complete Route 1 was 4 minutes 18 seconds.

DSTO-GD-0559

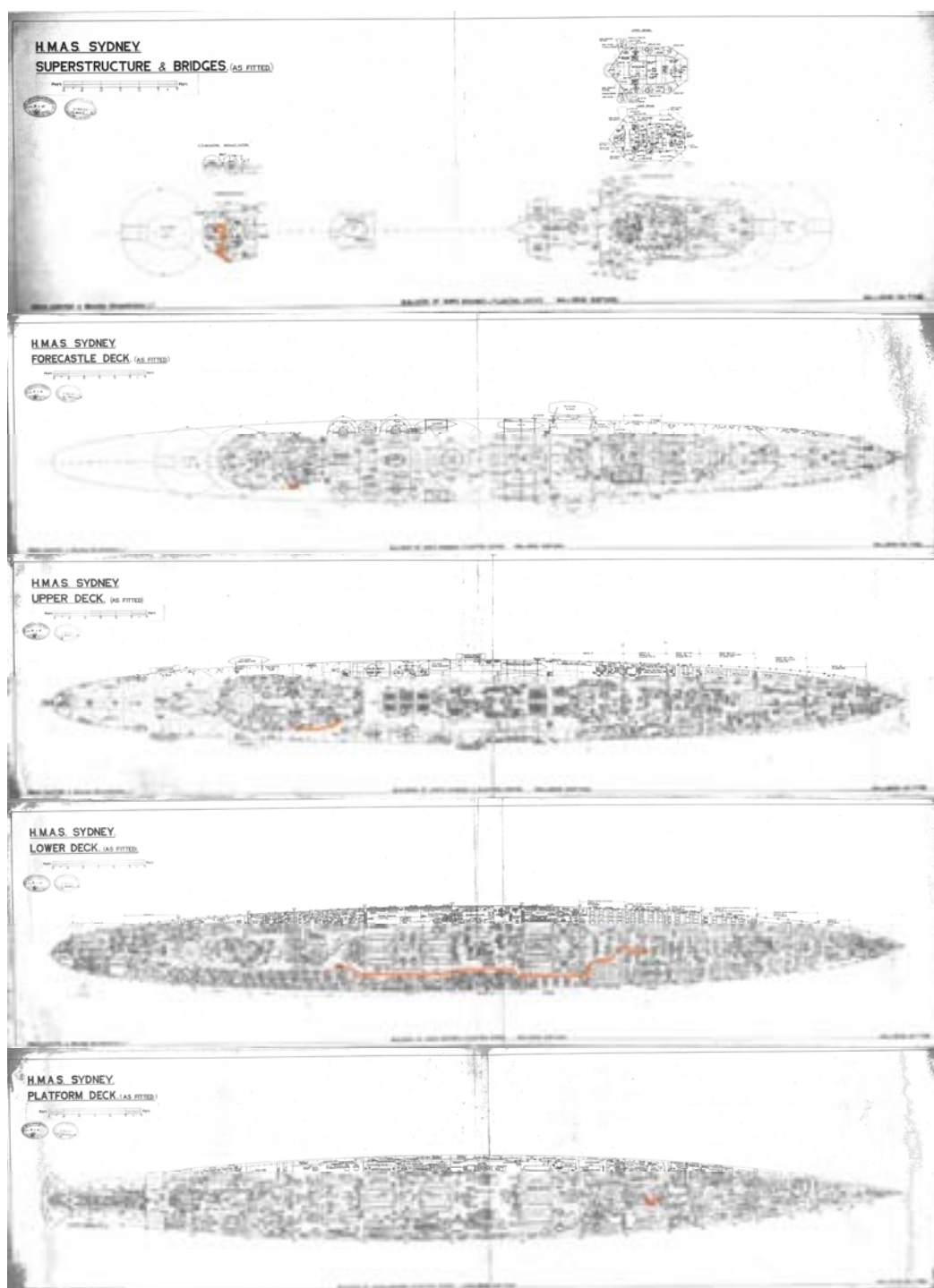

Figure 226: Route 1 from DCHQ to Aft Control Position

### 7.3.2 Route 2

Route 2 is illustrated in Figure 227. From the Platform deck, the XO was limited by one possible route to the Lower Deck, from the Lower Steering Position to the Lobby and up the ladder to No. 4 Lower Mess. From here he moved from No. 4 Lower Mess, through the Stoker's Mess and the Kit Locker Flat to the Engineer's Workshop. The ladder in the

DSTO-GD-0559

centre of the compartment was taken to the upper Deck arriving between the Bakery and the Mail & Regulating Office. The XO then moved along the starboard side of the deck and up the ladder outside the Captain's Pantry. He then moved up the ladder on the starboard side of the Forecastle deck structure to the aft Superstructure deck. The XO finally moved across the deck and into the Aft Control Position.

The time to complete Route 2 was 3 minutes 30 seconds.

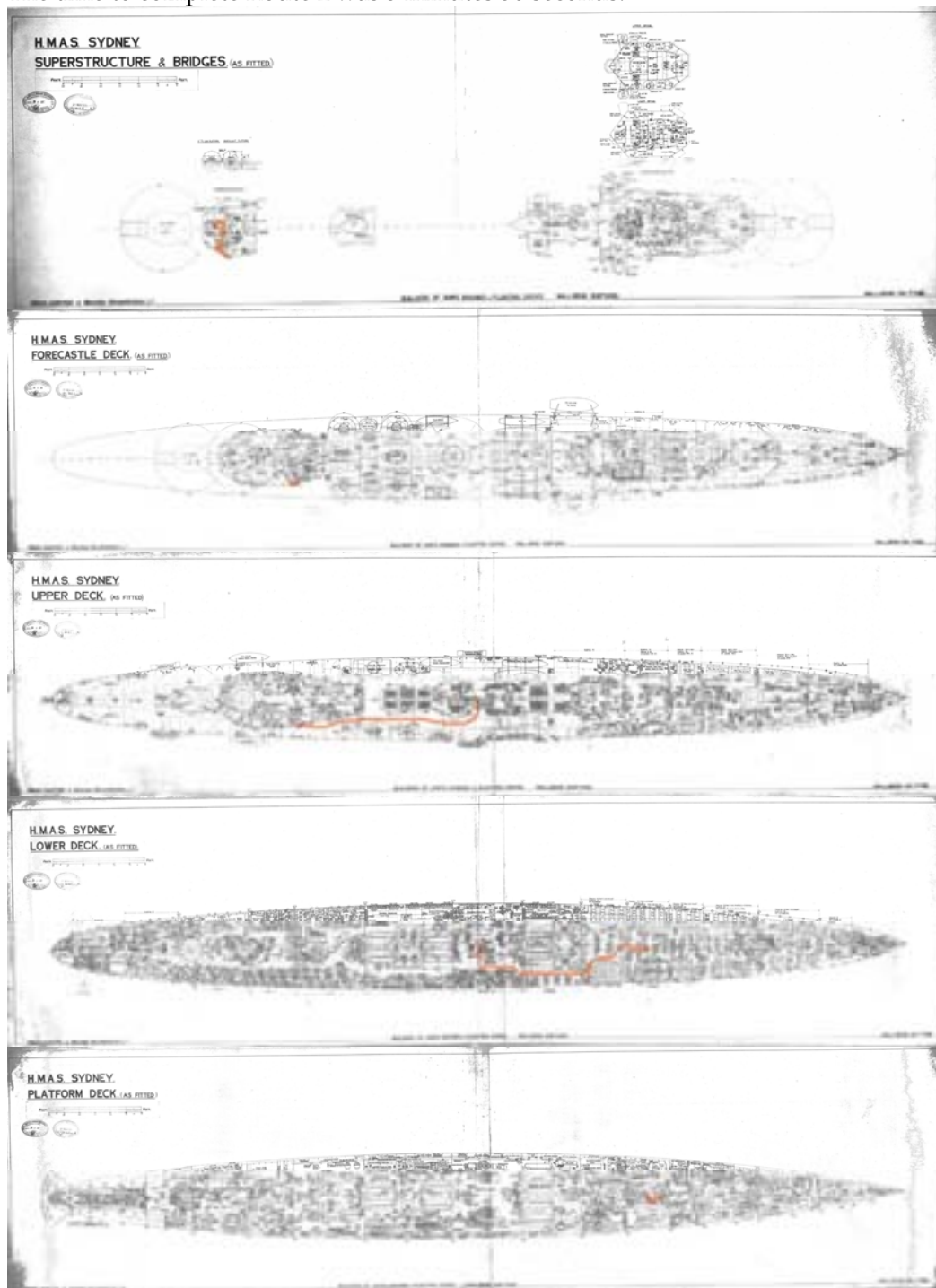

Figure 227: Route 2 from DCHQ to After Control Position

DSTO-GD-0559

### 7.3.3 Route 3

Route 3 is illustrated in Figure 228. From the Platform deck, the XO was limited by one possible route to the Lower Deck, from the Lower Steering Position to the Lobby and up the ladder to No. 4 Lower Mess. The XO moved through No. 4 Lower Mess to the ladder at the forward end of the compartment and up to the passage aft of the Cooks' Kitchen. The XO then moved along the starboard side of the deck and up the ladder outside the Captain's Pantry. He then moved up the ladder on the starboard side of the Forecastle deck structure to the aft Superstructure deck. The XO moved across the deck and into the After Control Position through the door.

The time to complete Route 3 was 2 minutes 35 seconds

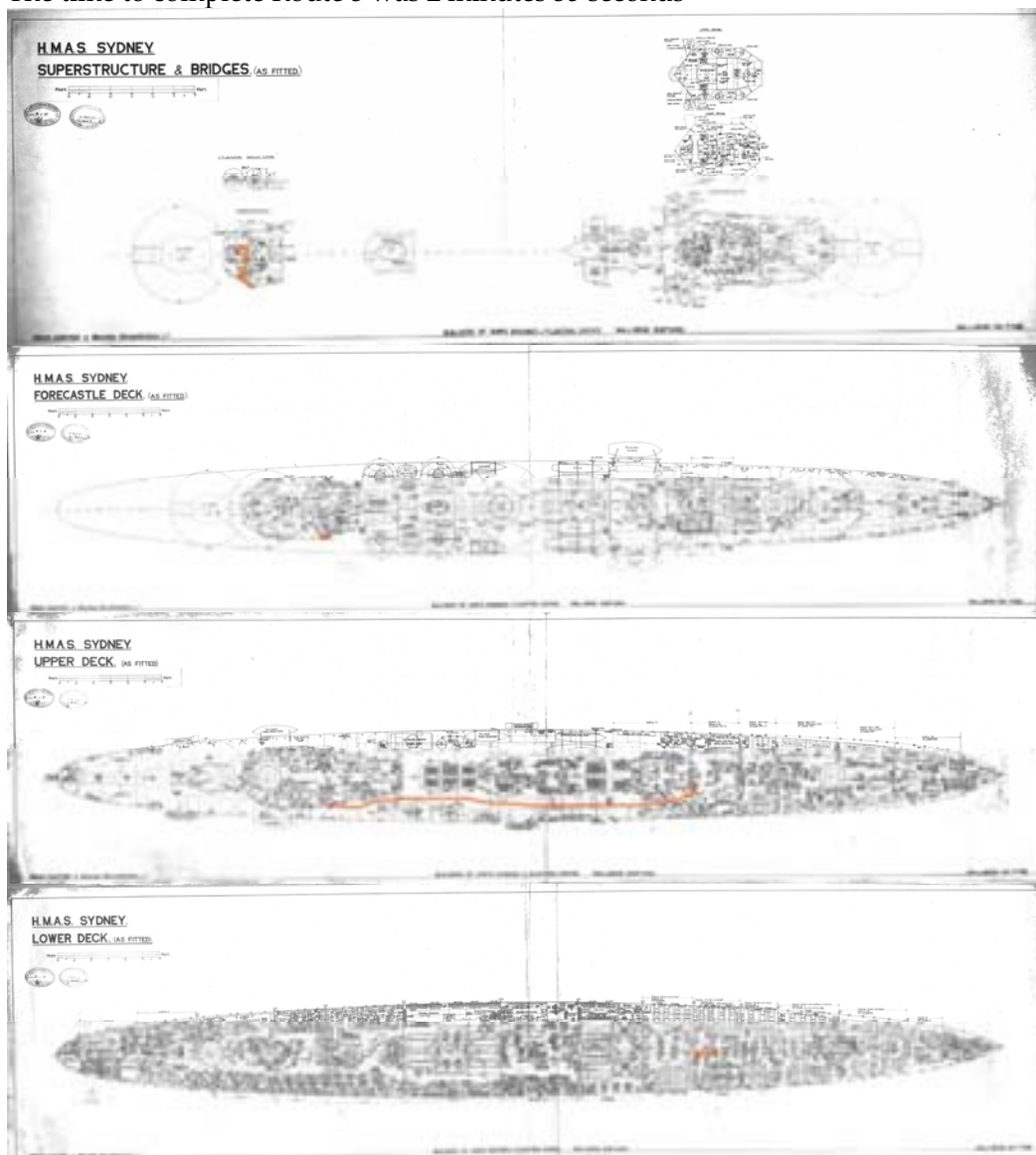

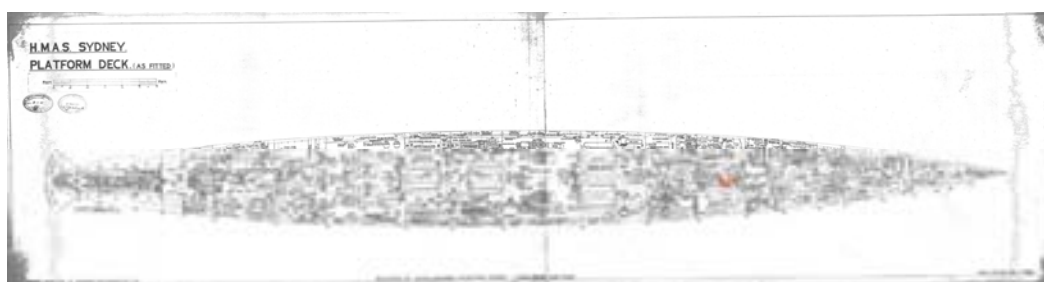
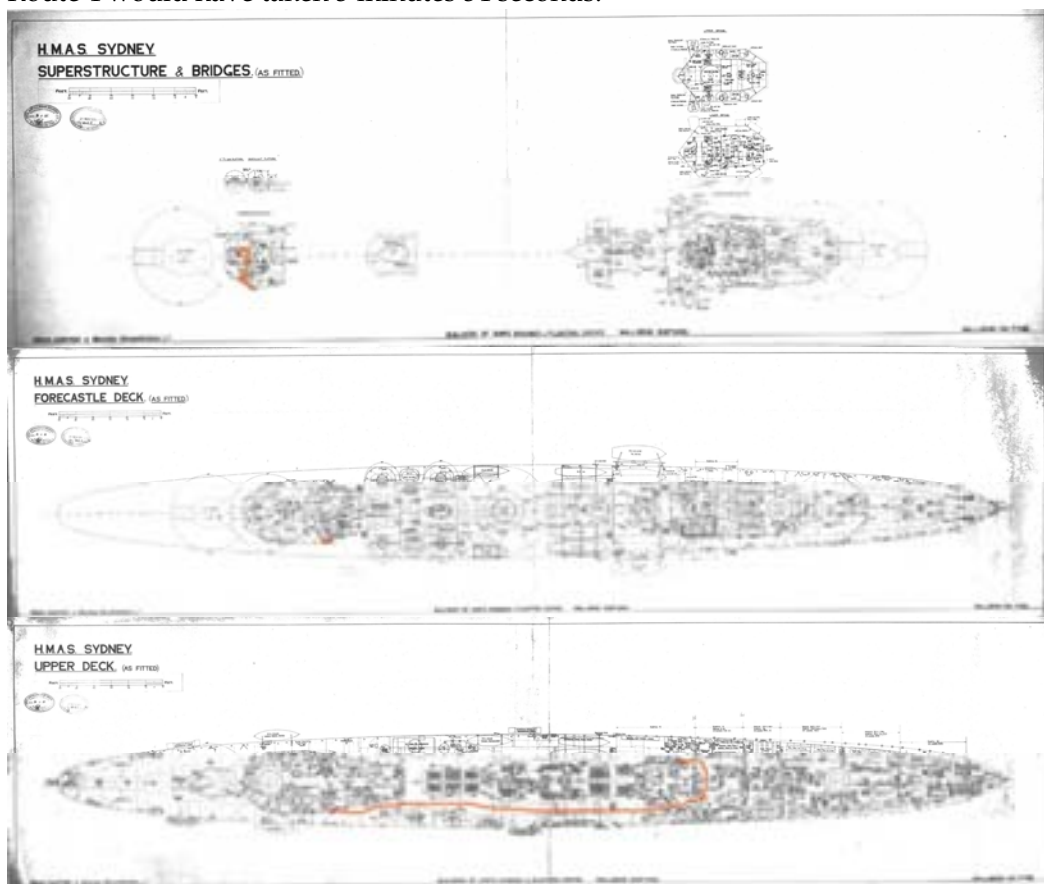

Figure 228: Route 3 from DCHQ to After Control Position

#### 7.3.4 Route 4

Route 4 is illustrated in Figure 229. From the Platform deck, the XO was limited by one possible route to the Lower Deck, from the Lower Steering Position to the Lobby and up the ladder to No. 4 Lower Mess. The XO moved along Lower Deck through No. 4 Lower Mess and into the Stokers' Mess. The ladder was taken to the passage on upper deck to the port side of the Cooks' Kitchen. The XO then moved aft and across to the starboard side through passages, along the starboard side of the deck and up the ladder outside of the Captain's Pantry. He then moved up the ladder on the starboard side of the Forecastle deck structure to the aft Superstructure deck. The XO finally moved across the deck and into the Aft Control Position.

Route 4 would have taken 3 minutes 34 seconds.



DSTO-GD-0559

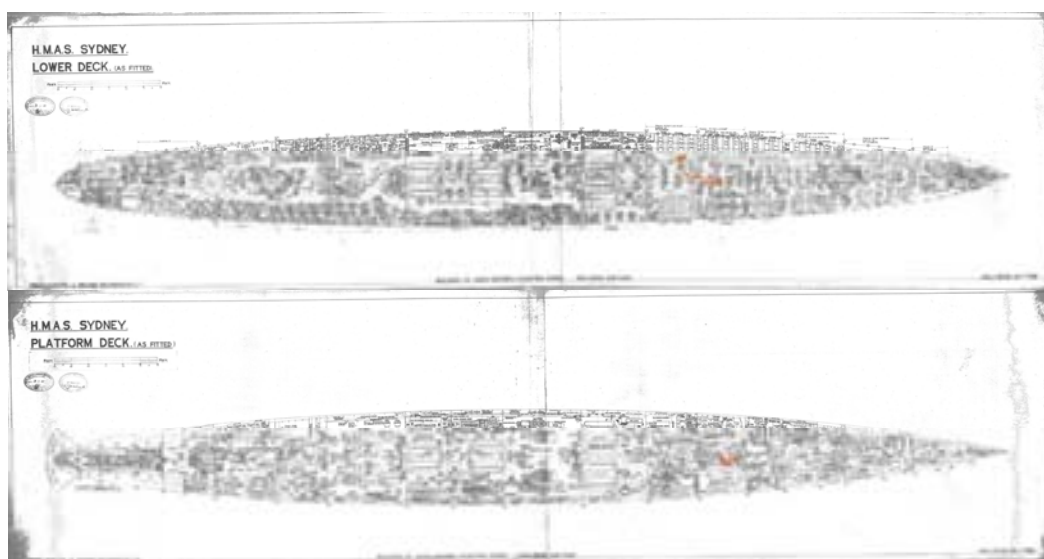

Figure 229: Route 4 from DCHQ to After Control Position

## 7.4 Turn to Port

The telemotor system was designed to provide some redundancy in the event of damage. Damage to the pipes on one side could be overcome by changing over to the pair of pipes on the other side of the ship. However, if for some reason air was introduced into the telemotor system as a result of the damage, the changeover might be ineffective, requiring transfer of steering control to the After Steering Position. *Sydney* appears to have been fitted with steering pedestals fitted with single transmitters. This arrangement increased the risk that a steering pedestal could become inoperative as a result of air in the system due to damage. It is known that Admiralty practice for steering gear telemotor transmitters in destroyers changed in the late 1930s requiring the installation of steering pedestals fitted with two transmitters to reduce the risk of loss of control as a result of the loss of fluid from one set of telemotor pipes [89]. There was some protection against this type of damage built into *Sydney's* telemotor system. For example, if the Wheelhouse transmitter was connected to one receiver by one pair of pipes, and the Lower Steering Position transmitter was connected to the other receiver by the other set of pipes then the loss of one pair of telemotor pipes would take only one steering pedestal out of action.

If the ship was maintaining a straight course when the pair of telemotor pipes in use was damaged the helmsman would find the wheel 'dead' in his hands – turning it would produce no effect. Changing over to the alternative pair of telemotor pipes would restore control, unless the system had become contaminated by air. Because air is compressible, moving the wheel would have little effect. The telemotor receiver would receive no signal from the helmsman and the rudder would remain amidships.

If helm had been applied immediately before the damage occurred, i.e. the ship was turning, then the loss of the telemotor pipes would allow the powerful spring in the telemotor receiver to return the rudder amidships, as if the helmsman had released hold of the wheel. If both forward steering positions were affected, transfer of the helm to the After Steering Position would restore control.



*Sydney* was observed by *Kormoran* to turn to port and crossed astern of *Kormoran*. It is not possible to say whether *Sydney* was being steered from forward or aft.

## 7.5 Starboard Side Engagement

*Kormoran* is thought to have continued to hit *Sydney* for another 20 minutes, hitting her with another 30 to 40 15 cm shells. This barrage would have consolidated the damage caused by the port barrage.

### 7.5.1 Shell damage

The location of the starboard side 15 cm hits to *Sydney* are shown in Figure 129 to Figure 133, which are widely distributed. Further hits to the Bridge and DCT have occurred. Yet more shells hit the mess areas in the Lower Deck. The concentration of shell hits around the midships section of the upper and Lower Decks, into the engineers workshop, upper section of the forward boiler room and the stokers mess had severe consequences. There were no shell hits apparent aft of the X turret.

A number of shell hits identified to the starboard side, have obviously been fired over the bow of *Sydney* as she turned. This is particularly evident from the four hits to the A turret's side plate.

A turret has received considerable damage from hits to the starboard side (Figure 230). The starboard side armour shows that A turret received four separate hits (Figure 233), two of which detonated on contact and the other two penetrated the armour plating. These hits would have destroyed this turret. These hits would have occurred with A turret pointed to port, possibly indicating that the hits occurred as *Sydney* swung around the aft of *Kormoran*.



Figure 230: Damage to A Turret [301]

The starboard side of the ship has also received a considerable amount of damage from weapon hits. On the DCT there is at least one, but possibly two additional hits to the support structure (see Figure 210) and another penetrating hit to the main DCT (Figure

DSTO-GD-0559

232). If any function in the DCT had remained operational after the hit to the port side, which is highly unlikely, the additional hits on the starboard side would have definitely put the DCT firing control permanently out of operation.

The bridge superstructure has also received additional hits on the starboard side, but again fire and sinking damage makes it difficult to categorically state that all the weapons hits have been identified (Figure 231).



Figure 231: Damage to bridge



Figure 232: Hit to DCT [302]

DSTO-GD-0559



*Figure 233: Starboard side armour of A Turret [303]*

Although, X Turret has received a hit on its port side armour, it is likely due to the port bearing of the gun that this hit came in from the starboard side (Figure 234). This shell has penetrated the gun turret and there is evidence that it has detonated inside removing the rear port hatch [304].



*Figure 234: Hit to X turret [305]*

There is also damage to the starboard side torpedo tubes which is either a result of a shell hit, or due to fragment damage (Figure 235). This hit would have essentially disabled these torpedo tubes preventing them from being fired.

DSTO-GD-0559



Figure 235: Damage to starboard side torpedo tube [306]

The starboard side of Sydney has also received multiple hits along the hull, particularly around the armour plating protecting the engine room. The value of the armour plating around the engine space is demonstrated by a number of these hits, where there is obvious shell impact, but it has not penetrated the hull (Figure 236). A number of hits have penetrated the armour plating and Figure 237 shows a hit that has probably penetrated the armour and possibly detonated inside *Sydney*. Figure 238 and Figure 239 show hits that have probably detonated on the outside of *Sydney*, but the fragments from the detonation have penetrated the armour. The hits in Figure 238 and Figure 239 would have caused some internal damage to *Sydney*, but this damage would be much less than if the shell had detonated on the inside of the ship. It is also interesting to note that a number of the hits on the armour plating appear to have impacted at an angle. For example the hit shown in Figure 238 is likely to have been fired from a position somewhere forward of *Sydney*. This is evident from the direction of the fragment markings on the hull. It is not possible from the evidence available to predict the angle at which this shell hit *Sydney* with any accuracy. Shell detonations in general would have been responsible to spraying fragments over the deck; this may have damaged the surrounding structure such as the boats and aircraft on the deck of *Sydney*. Figure 240 is a good example of a hit that is likely to have sprayed numerous fragments over the surrounding deck.



*Figure 236: Non-penetrating shell damage to the armour plating [307]*

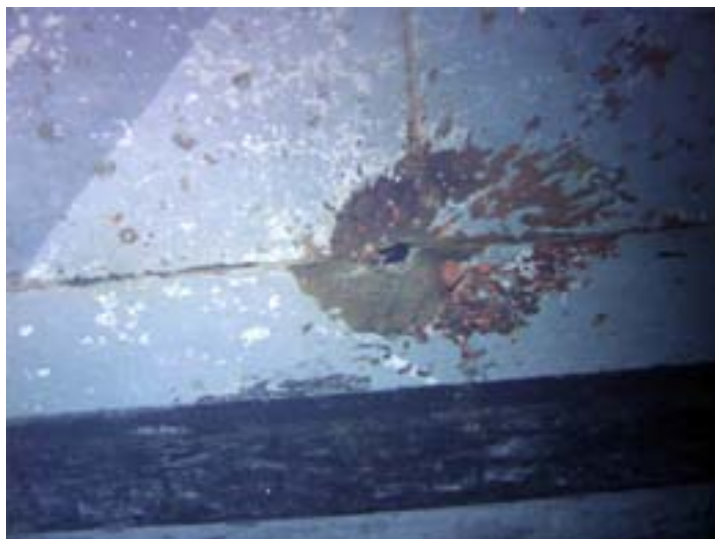

*Figure 237: Penetration to armour plating [308]*

DSTO-GD-0559



*Figure 238: Example of a shell that has probably hit Sydney on an angle [309]*



*Figure 239: Example of shell that has hit the armour with fragments causing the penetration  
(Note: Port side hit) [310]*



*Figure 240: Example of shell damage that probably sprayed hot fragments over the surrounding deck [311]*

There is some evidence of fragment damage to the boats but the extent is difficult to determine for the reasons outlined in Chapter 4. All the boats show some degree of physical deterioration but they do not tend to show any significant fire damage. One of the Motor boats also shows extensive physical damage possibly due to an impact by a large object that has crushed a large section and almost broken the boat in two. Interestingly, next to this boat in the debris field is the remains of the seaplane catapult that may have hit the boat during the action or during the sinking. Given the difference in the physical state of the two 35' Motor boats, and knowing that they were next to each other on the starboard side, they could be expected to have similar damage. The fact that one shows far greater damage could be due to factors other than the weapons effects. The Whaler does show a single large shell hole in the frame indicative of weapon damage. The reconstruction of the starboard area showing the boats that would have been damaged by fragments sprayed onto the deck is shown in Figure 241.



*Figure 241: Reconstruction of midships*

DSTO-GD-0559

All the boats cradles show varying degrees of fragment or weapons damage. This suggests that the boats would have suffered varying degrees of damage to the point that they were most likely to be un-useable for evacuation purposes.

The photographic evidence showing that the davits for the Cutter are not in place suggests that the Cutter was either blown off Sydney during the encounter or fell into the sea when their davits were destroyed due to weapons effects. Due to this, it would be most unlikely that the Cutters would have been in a physical state to be used for any life-saving capacity.

It is perhaps instructive to note that during the encounter between *Sydney* and the Italian cruiser *Bartolomeo Colleoni*, a single projectile which burst on the No. 1 funnel port side caused a number of jagged holes in the Pinnacle, the Skiff and the Whaler [128]. The damage was sufficient to request that repairs be carried out to the ship's boats – the Pinnacle required replacement of 40 planks, the Skiff was not able to be repaired by the ship's crew and 4 planks were repaired in the Whaler.

### 7.5.2 Fire Damage

The main fire in the forward section would have grown to a large conflagration during this period. Smoke from this fire would have been drawn into the forward machinery spaces due to the location of the ventilation inlets. Shell hits on the aft superstructure near the X turret would have ignited more fires during this period.

### 7.5.3 Casualties

By the time *Sydney* made its turn, *Kormoran* had been continuously firing for 5 minutes, numerous fires would have started and the casualty level on Sydney from the weapons was extremely high. The remaining damage control crews would be starting to be overwhelmed.

During the turn, *Kormoran* was only able to bear 2 guns on to *Sydney* but the firing did not let up. One major hit after the turn to starboard was to the 'X' turret. This would have caused (or expanded) the fire around the After Control Tower and the Senior Officers Cabins below.

The cumulative damage and casualties are discussed below.

## 7.6 Point of Disengagement

This section describes what action were being conducted onboard *Sydney* following the point of disengagement. It concentrates on activities that could have been carried out onboard in terms of damage control and describing the surroundings in which the crew may have been operating.



## 7.6.1 Integrity of ship

### 7.6.1.1 Overall Shell Damage

The following provides a summary of the overall shell damage received by *Sydney* and also considers the consequences on the ship's capabilities after the battle. This analysis has been carried out using XVAM, which is the vulnerability assessment code used.

#### 7.6.1.1.1 Description of damage to *Sydney* via XVAM analysis

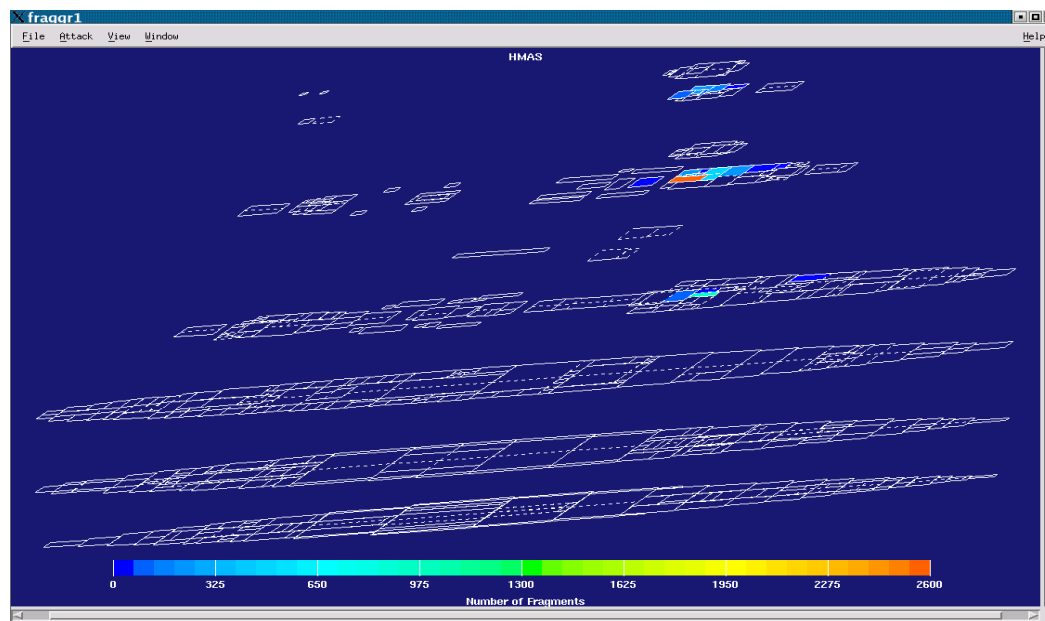

Figure 242: XVAM output prediction of the likely spread of fragments throughout the ship from a single 15 cm shot

A typical output of the model used to undertake the vulnerability analysis is provided in Figure 242. The model produces a fragment penetration analysis, the results of which are shown in Figure 242. The analysis involved the calculation of the likely spread of both blast and fragments through the adjacent structure. For the shot shown in Figure 242 the area highlighted in orange is the likely detonation point, the number of fragments penetrating into adjacent compartments is a function of the velocity and mass of the fragments and the thickness and material of the intervening bulkhead. The colour scale indicates the number of fragments and the probability that the fragments will extend past the compartment in which the detonation occurred.

The combined effect of the 87 15 cm shells which have been observed to have hit *Sydney*, are shown in Figure 243 to Figure 248. The zones hatched red have a high probability of being affected by the fragments and blast resulting from the effects of the detonating 15 cm shells, and the damage incurred due to the flight path of the AP shells into the structure. Overlaid onto this damage are the regions directly affected by the torpedo (hatched in blue) and the areas vulnerable and mentioned by *Kormoran* survivors as being hit by the smaller calibre 20 mm and 3.7 cm shells (shown hatched in grey).

DSTO-GD-0559

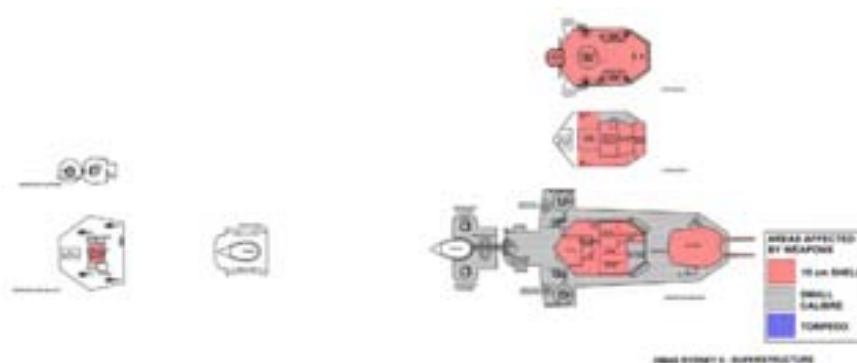

Figure 243: Predicted extent of weapon damage to superstructure and bridge compartments

Most of the superstructure and bridge compartments have been assessed as being affected by fragment damage and the exposed spaces on the Superstructure deck would have been highly likely to have sustained damage due to small calibre weapons and fragments. All equipment and personnel in these areas are deemed as incapacitated.

The Forecastle deck (Figure 244) was very exposed to small calibre weapons and the effects of thousands of fragments generated from hits to the forward superstructure region and the hits on the catapult and similar regions. The boats, Carley floats and personnel on this deck would be assumed to have been severely affected.

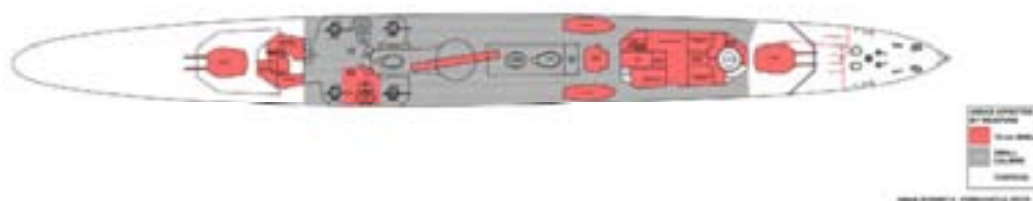

Figure 244: Predicted extent of weapon damage to Forecastle deck compartments

The extent of damage to the forward upper deck region (Figure 245) is significant. The number of hits identified would have severely limited the access and passage to the damage control crews in not only repairing the damage from the torpedo, but fighting the fires and repairing the associated damage from the shell hits in this region, the superstructure and bridge compartments.

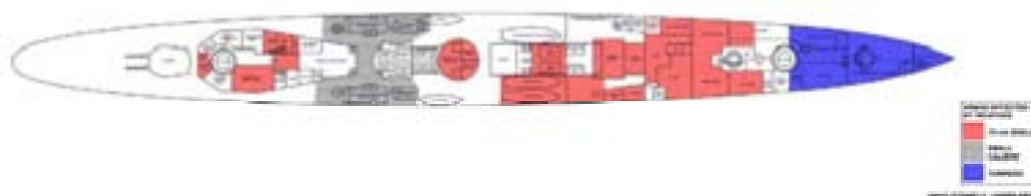

Figure 245: Predicted extent of weapon damage to upper deck compartments

DSTO-GD-0559

There is extensive damage to the lower deck mess compartment (Figure 246) from shell fragments and debris. The extremely important Damage Control Stations 1 and 2 have been showered with fragments which would have led to a large number of casualties from crew involved in repairing the ship and controlling the flooding and fires.



Figure 246: Predicted extent of weapon damage to lower deck compartments

Damage to the forward section of the platform deck (Figure 247) indicates important areas such as the forward steering room, switchboard room and breaker rooms being hit by weapon fragments. It is important to note that the aft compartments of this platform are free of any weapon damage.



Figure 247: Predicted weapon damage to platform deck compartments

Apart from the torpedo damage, the hold (Figure 248) is intact from weapons damage. However there would be limited access to these areas due to the weapon effects in the upper decks, especially in the forward part of the structure.



Figure 248: Predicted extent of weapon damage to hold

The resultant crew casualties in internal spaces of the ship are shown in the following figures. These figures need to be used in conjunction with Figure 249 to Figure 254. Furthermore they do not include the effects of the smaller calibre 20 mm and 3.7 cm guns. The red regions indicate areas in which all crew would have been incapacitated at the time of the hit and unable to continue with ship operational duties.

DSTO-GD-0559

The torpedo damage is only shown to indicate compartments not operational. Crew casualties from the torpedo would extend back to B turret, and other casualties due to the explosion shock would be distributed around the ship.

Figure 249 is purely the casualty level expected in the compartments from the identified shell hits. Exposed personnel and equipment would have had high casualty levels in all areas due to fragments and smaller calibre weapons. Kormoran survivors mention that the 3.7 cm gun was trained on the bridge region.

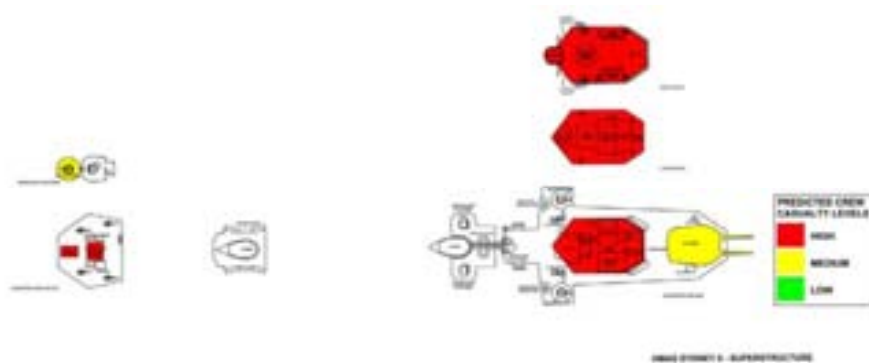

Figure 249: Probability of crew casualties in the Superstructure deck compartments resulting from 15 cm shell hits

Figure 250 show the probability of casualties in spaces defined by the analysis. Again extensive damage from the smaller calibre weapons would result in high casualty levels to both the exposed crew and equipment on this deck.

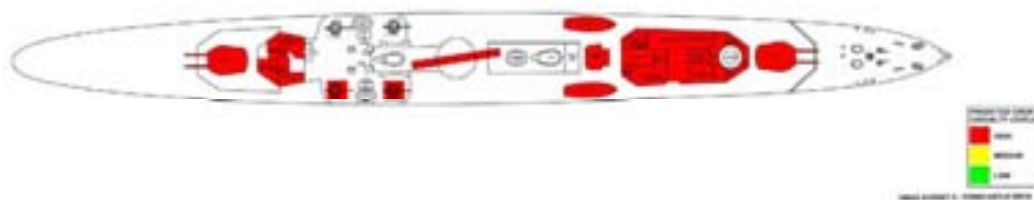

Figure 250: Probability of crew casualties on the Forecastle deck resulting from 15 cm shell hits.

Figure 251 shows casualties in spaces on the upper Deck. Extensive damage to the forward spaces is shown. The torpedo damage highlighted is purely the structural damage. Personnel and equipment in Turret A zones would have high rates of casualties due to the torpedo effects on this zone.

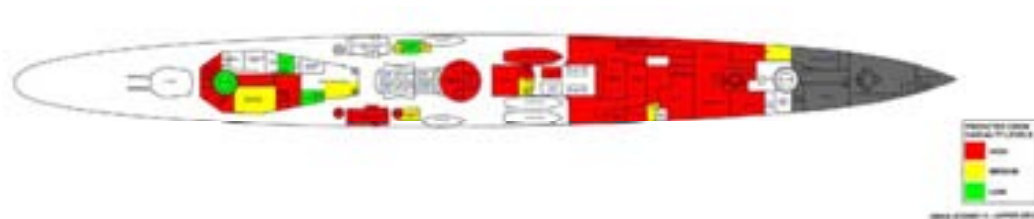

Figure 251: Probability of crew casualties resulting from a 15 cm shell into the upper deck

DSTO-GD-0559

Figure 252 illustrates that the main Damage Control Stations in the engineering workshop and lower mess 2 have high rates of casualties. The torpedo damage shown is purely structural.



Figure 252: Probability of crew casualties resulting from a 15 cm shell into the lower deck

Major compartments of interest in Figure 253 are the switchboard room, lower steering room, and breaker rooms. Each has been estimated to have received a certain amount of damage.

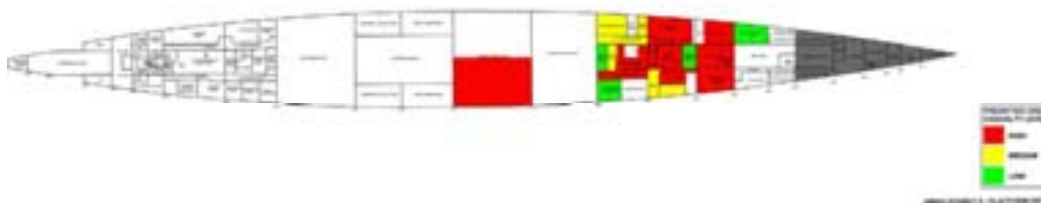

Figure 253: Probability of crew casualties resulting from a 15 cm shell into the platform deck

Figure 254 indicates that no crew casualties from direct weapons effects were expected in the hold.

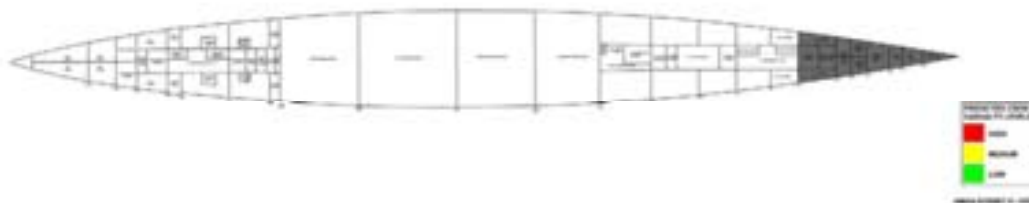

Figure 254: Probability of crew casualties resulting from a 15 cm shell into the hold

#### 7.6.1.1.2 Estimate of casualties

An accurate estimate of the number of casualties resulting from the battle damage is extremely difficult to determine. Limited information is available on the location of the crew at Action Stations. Also the dynamic nature of the battle, over a timeframe of 30 minutes meant that the exact location of the crew at any time will never be known.

The battle was unique in not only was the crew subjected to a constant barrage of 15 cm shells, they were continually being subjected to attack by 20 mm and 3.7 cm shells. Furthermore they had to control the ship which had been holed by a torpedo. Over this time frame numerous fires were burning, spreading plumes of smoke over and throughout the ship.

DSTO-GD-0559

Based on the available data a likely scenario of the casualties that can be directly related to the battle engagement is shown in Table 24. The data predicts a casualty level of 450 or 70% of the crew being incapacitated by the effects of the battle weapons and being trapped in spaces due to fires. The table has two columns for casualty numbers, the first is purely from weapons effects (torpedo, 15 cm shells, small calibre shells) the second column is with the additional crew lost due to lack of escape routes from fire, smoke and weapon damage.

It would be expected that the remaining crew would be below decks in the aft end of *Sydney*, trying to control the ship, managing the wounded and possibly trying to conduct DC operations.

*Table 24 Estimated Sydney crew casualties at the end of the battle based on possible scenario shown*

| Location              | Assumed Crew Number | Probability of casualties due to Weapons Effects | Probability of casualties due to Fire/Smoke/Evacuation Effects        |
|-----------------------|---------------------|--|---|
| Bridge                | 20                  | HIGH 15 cm and 3.7 cm Shell                      | HIGH – escape routes affected by structural damage and fire and smoke |
| DCT                   | 8                   | HIGH 15 cm Shell                                 | HIGH – escape routes affected by structural damage and fire and smoke |
| HACS                  | 5                   | HIGH 15 cm Shell                                 | HIGH – escape routes affected by structural damage and fire and smoke |
| Flag Deck             | 15                  | HIGH Small calibre Shells and fragments          | LOW – access to open deck   |
| Turret A              | 20                  | HIGH Torpedo/shell                               | LOW – access to open deck   |
| Turret B              | 20                  | HIGH 15 cm Shell                                 | LOW – access to open deck   |
| Turret X              | 20                  | HIGH 15 cm Shell                                 | LOW – access to open deck   |
| Turret Y              | 20                  |  | LOW – access to open deck   |
| Aft Control           | 3                   | HIGH 15 cm Shell                                 | LOW – access to open deck   |
| Aft Searchlight       | 2                   | HIGH fragments                                   | LOW – open deck   |
| Fwd Searchlight       | 4                   | HIGH Small calibre weapon                        | LOW – open deck   |
| Shell Rm A            | 4                   | HIGH Torpedo shock                               | HIGH – escape routes affected by structural damage and fire and smoke |
| Shell Rm B            | 4                   | LOW Torpedo shock                                | HIGH – escape routes affected by structural damage and fire and smoke |
| Shell Rm X            | 4                   |  | MEDIUM - escape routes affected by structural damage                  |
| Shell Rm Y            | 4                   |  | LOW – escape route available  |
| A B Mag               | 4                   | LOW Torpedo shock                                | HIGH – escape routes affected by structural damage and fire and smoke |
| X Y Mag               | 4                   |  | MEDIUM - escape routes affected by fire and smoke                     |
| Cordite/Handling Rm A | 3                   | LOW Torpedo shock                                | HIGH – escape routes affected by structural damage and fire and smoke |
| Cordite/Handling Rm B | 3                   | LOW Torpedo shock                                | HIGH – escape routes affected by structural damage and fire and smoke |
| Cordite/Handling Rm X | 3                   |  | MEDIUM - escape routes affected by structural damage                  |
| Cordite/Handling Rm Y | 3                   |  | MEDIUM - escape routes affected by structural damage                  |
| 4" Deck               | 30                  | HIGH small calibre weapon and shell fragments    | LOW – open deck   |
| Port Torpedoes        | 6                   | HIGH small calibre weapon and shell fragments    | LOW – open deck   |

|                           |    |   |   |
|---------------------------|----|---|---|
| Stbd Torpedoes            | 6  | HIGH small calibre weapon and shell fragments | LOW - open deck   |
| Machine Gun Mounts        | 9  | HIGH small calibre weapon and shell fragments | LOW - open deck   |
| Quarter Deck Depth Charge | 4  |   | LOW - open deck   |
| Aft Steering Comp         | 5  |   | LOW - escape route available  |
| Aircraft                  | 7  | HIGH small calibre weapon and shell fragments | LOW - open deck   |
| Catapult                  | 5  | HIGH small calibre weapon and shell fragments | LOW - open deck   |
| Lower Steering Pos        | 7  | LOW 15 cm shell                               | HIGH - escape routes affected by structural damage and fire and smoke               |
| MAIN w/t                  | 12 |   | MEDIUM - escape routes affected by fire and smoke                                   |
| 2 nd W/T                  | 5  | MEDIUM 15 cm shell                            | HIGH - escape routes affected by structural damage and fire and smoke               |
| Aux W/T                   | 5  | HIGH 15 cm shell                              | HIGH - escape routes affected by structural damage and fire and smoke               |
| Telephone Exchange        | 3  | HIGH 15 cm shell                              | HIGH - escape routes affected by structural damage and fire and smoke               |
| Ammo Lobby A              | 10 | HIGH Torpedo shock/shell damage               | HIGH - escape routes affected by structural damage and fire and smoke               |
| Ammo Lobby B              | 10 | HIGH Torpedo shock/ shell damage              | HIGH - escape routes affected by structural damage and fire and smoke               |
| Ammo Lobby X              | 10 |   | LOW - escape route available  |
| Ammo Lobby Y              | 10 |   | LOW - escape route available  |
| HACP                      | 11 |   | HIGH - structural damage to escape routes, escape routes affected by fire and smoke |
| TS                        | 20 |   | HIGH - structural damage to escape routes, escape routes affected by fire and smoke |
| Low Power 1               | 2  |   | HIGH - escape routes affected by structural damage and fire and smoke               |
| Low Power 2               | 2  |   | HIGH - escape routes affected by structural damage and fire and smoke               |
| Switchboard               | 2  | MEDIUM 15 cm Shell                            | HIGH - escape routes affected by structural damage and fire and smoke               |
| Breaker 1                 | 1  | MEDIUM Torpedo shock                          | HIGH - escape routes affected by structural damage and fire and smoke               |
| Breaker 2                 | 1  | MEDIUM Torpedo shock                          | HIGH - escape routes affected by structural damage and fire and smoke               |
| Breaker 3                 | 1  | HIGH 15 cm Shell                              | HIGH - escape routes affected by structural damage and fire and smoke               |
| Breaker 4                 | 1  | MEDIUM 15 cm Shell                            | HIGH - escape routes affected by structural damage and fire and smoke               |
| Breaker 5                 | 1  |   | MEDIUM - structural damage to escape route  |
| Breaker 6                 | 1  |   | LOW - escape route available  |
| Diesel Dynmo Port         | 2  |   | LOW - escape route available  |
| Diesel Dynmo Stbd         | 2  |   | LOW - escape route available  |
| Fwd Boiler                | 40 | MEDIUM to top half of space shell damage      | MEDIUM - large compartment affected by smoke  |
| Fwd Engine Rm             | 37 | MEDIUM to top half of space fragment damage   | MEDIUM - large compartment affected by smoke  |
| Aft Boiler                | 38 | LOW fragment damage                           | LOW - escape route available  |
| Aft Engine Rm             | 37 |   | LOW - escape route available  |

DSTO-GD-0559

|                            |            |                    |   |
|----------------------------|------------|--------------------|---|
| Fwd Pump Lobby             | 2          | HIGH Torpedo shock | HIGH – escape routes affected by structural damage and fire and smoke |
| Fwd Compressor Room        | 2          | HIGH Torpedo shock | HIGH – escape routes affected by structural damage and fire and smoke |
| Aft Pump & Compressor Room | 2          |                    | MEDIUM – structural damage to escape route                            |
| Chart & Chrono Room        | 2          | HIGH 15 cm Shell   | HIGH – escape routes affected by structural damage and fire and smoke |
| Fwd Gyro                   | 2          |                    | HIGH – escape routes affected by structural damage and fire and smoke |
| Aft Gyro                   | 2          |                    | LOW – escape route available  |
| DC 1 Lower Mess No 2       | 30         | HIGH 15 cm Shell   | HIGH – escape routes affected by structural damage and fire and smoke |
| DC 2 Engineering W/Shop    | 40         | HIGH 15 cm Shell   | MEDIUM– escape routes affected by structural damage and smoke         |
| DC 3 Half Deck Flat        | 28         | HIGH 15 cm Shell   | LOW – escape route available  |
| Ward Room Flat             | 5          | LOW 15 cm Shell    | MEDIUM – structural damage to escape route                            |
| Sick Bay                   | 5          | HIGH 15 cm Shell   | HIGH – escape routes affected by structural damage and fire and smoke |
| Galley                     | 5          | HIGH 15 cm Shell   | HIGH – escape routes affected by structural damage and fire and smoke |
| 4" HA Mag                  | 4          |                    | HIGH – escape routes affected by structural damage and fire and smoke |
| <b>Total Crew</b>          | <b>645</b> |                    |   |

#### 7.6.1.1.3 Weapon Effects Conclusions

Observations from *Sydney* wreck site confirm *Kormoran* survivor's accounts of *Sydney* being hit in the bow by a torpedo and peppered with a large number of shells to both the port and starboard sides of the ship.

Observations from footage of *Sydney* wreck site identify 87 individual 15 cm shell hits. Each of these shells had a weight of 45.3 kg, which represents a total weight of 3900 kg hitting *Sydney*. Each of these shells is designed to splinter on impact, which would have generated a minimum of 200,000 individual steel fragments from their detonation and thousands of secondary fragments would have been generated by the shells as they smashed through *Sydney*. It is reasonable to suggest a significant number of hits to the upper deck regions cannot be identified due to the condition of the ship in its present state, so these numbers could be viewed as conservative.

The internal structure of the ship gave some protection to the crew and equipment from the fragments generated by these shells penetrating through the ship. Some fragment protection was due to the inherent resistance of the structure of the warship, but also due to the armoured spaces of the engine room, magazines, and gun lobbies. Exposed personnel, boats, and other equipment on the upper decks had no protection and were extremely vulnerable to fragment hits.

Although, it was not possible to identify damage from the smaller calibre shell impacts to *Sydney* from the photographs. *Kormoran*'s survivors accounts state that both the 20 mm and 3.7 cm guns peppered the upper decks and the bridge structure of *Sydney*. The



failure to identify the damage is more a result of the state of the wreck and the inability to resolve small sized objects from the photographs.

*Kormoran* could bring to bear three 20 mm guns at a time, each with a conservative firing rate of 100 rounds per minute (its design firing rate is stated as 240 rpm). It is would be reasonable to suggest that they would have sprayed *Sydney* with between 500 to 1000 rounds per gun during the encounter. These 1500 rounds would have been directed towards the exposed personnel and equipment on the upper decks. Although the effectiveness to penetrate steel plate was limited at large stand-offs, exposed personnel were vulnerable up to 4000 m.

*Kormoran's* survivors have also stated they fired its 3.7 cm gun directed towards the bridge and superstructure regions. This gun had a more effective range than the 20 mm gun and had a rate of fire of 80 rounds per minute of the 0.7 kg AP shell. It is reasonable to suggest that *Kormoran* may have hit *Sydney* at least 400 times during the encounter, which would have added another 300 kg of steel fragments distributed around the upper decks and further added to the number of personnel critically wounded.

Further confirmation of *Kormoran's* survivors accounts are the observed 15 cm hits to both the DCT and HACS which would have effectively disabled the *Sydney* crew 's ability to accurately fire their weapons, if they were still operational. Although the weapons could fire from local control, this was a worst case scenario for *Sydney* as it was possible, but the probability of hitting a target would have been extremely unlikely.

The widespread distribution of observed hits over *Sydney* would mean the possibility of crew not wounded on the exposed upper deck to be extremely low. This would also be the case for the bridge and upper superstructure areas.

### 7.6.2 Damage Control

*Sydney* received numerous hits over an extended time frame. Where possible the crew would have assessed the damage, and commenced damage control in order to reduce the spread of damage and keep the ship afloat. Based on the equipment available on the ship and damage control efforts of other damaged ships, the following areas are those which the crew would be likely to pursue. The damage control efforts would have been dependent on the number of crew available, damage to equipment, access to parts of the ship which may be burning, filled with smoke, or damaged to an extent that access was not possible.

A summary of the damage sustained by weapons, torpedoes and fires is shown in Figure 255 and Figure 256.

DSTO-GD-0559

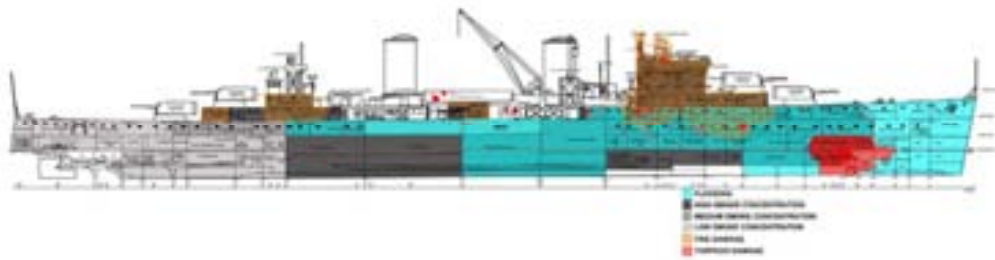

Figure 255: Port side total damage profile prior to sinking

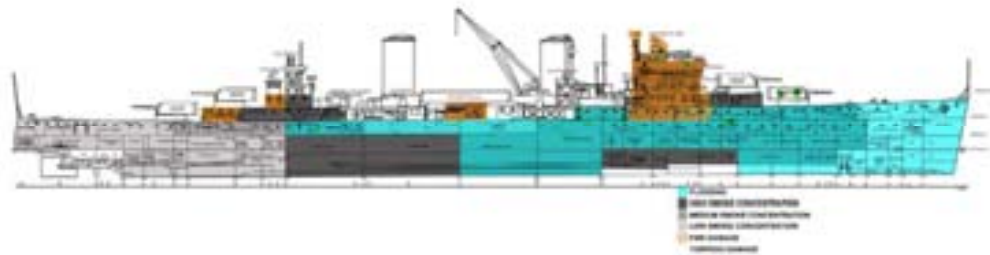

Figure 256: Starboard side total damage profile prior to sinking

#### 7.6.2.1 Access

Weapon damage would have caused considerable difficulty for the crew to move about the ship to escape from internal areas or to conduct damage control activities. As an example of damage, Figure 257 shows the damage caused to a partition bulkhead from the internal blast from a 4.75 kg cased charge during an experiment on ex - HMAS Derwent [285]. The bulkhead is joined by bolts or rivets. Such internal damage can occur to doors, hatches, ladders, and provides obstructions to movement; particularly where lighting is lost due to damage or when smoke is present.



Figure 257: Damage to a bulkhead from the internal blast from a 4.75 kg cased charge [285]

### 7.6.2.2 *Flooding*

To reduce the effects of flooding in Sydney the crew would have attempted to reduce the ingress of water and remove flood water in the ship. This would have included pumping water out of the ship using the fixed pumps and main suction line, and portable pumps. These required electrical power.

Shoring of leaking doors and hatches would have reduced the ingress of water, as would plugging holes and tears in the structure. Shoring of a forward bulkhead in order to protect it from collapse due to pressure of flood water from the torpedo damage was a likely action. However, movement of equipment of shoring timber through the ship would have been made more difficult due to the fires, smoke and internal damage from the shell hits.

### 7.6.2.3 *Fire fighting*

Fire damage is evident in three sections of the ship, shown in Chapter 6. The forward superstructure including the Bridge to Lower deck, the structure below the aircraft catapult, and the aft superstructure down to Lower deck was burnt. A great number of fires are likely to have been ignited from the large number of shell hits in the forward section, which would have coalesced to a single conflagration.

Fire fighting would have been undertaken with fire hoses from hose connection points, which required an intact section of the main service line, or firemain, and operational fire pumps to supply this line. The fire pumps in turn required electrical power. The main service line ran as a single pipe along the underside of the upper Deck, through the Platform Deck. The predicted extent of weapon damage intersects three complete sections of the main service line (between watertight bulkheads) on the Platform deck. The main service pipe is likely to have been severed in several places early in the engagement.

It may have been possible to use the main suction line to provide water for fire fighting. However, this would have been achieved by cross connecting pipes to the main service line and onto fire fighting equipment, such as fire hose connections. Given the predicted damage to the main service line, it is considered that this would not have been possible in the forward section of the ship.

The main service line was probably operational from the aft machinery spaces. Predicted weapon damage on the Lower Deck, above the aft machinery spaces, is considered to have deleteriously affected vertical rising mains from the main service, reducing the number of available fire hose connections on the upper decks midships.

### 7.6.2.4 *Smoke ingress*

Smoke from fires on the ship was likely to have been drawn into the ventilation system to other parts of the ship and through shell holes. For machinery spaces, air supply was required to feed the boilers and to cool the spaces. Some breathing apparatus was probably available for these spaces. If smoke levels were too great for personnel to operate, one or two spaces could be closed down, leaving at least one engine room and one boiler room operational. The location of the machinery space air inlets make it likely

DSTO-GD-0559

that smoke from fires in the forward superstructure and below the catapult was taken into the machinery spaces.

Given the predicted extent of weapon damage to the forward machinery spaces it was probable that these spaces were closed down, and the aft machinery spaces retained. While this would reduce the capability of the ship in terms of speed, electrical power generation, firemain supply, and flood water pumping ability, the ship could operate with one set of machinery spaces.

Smoke would have posed a problem for the crew in the aft machinery spaces. For compartments outside the machinery spaces, electric ventilation fans could be stopped. Valves within the ventilation system would need to be closed regardless of the state of fan motors, to stop the ingress of smoke. If fan motors were operational then some recirculation of air would have been possible.

#### *7.6.2.5 Electrical*

The electrical power supply was important to the ship for the following equipment; lighting, fire and bilge pumps, ventilation, and steering. The high power electrical ring main should have been divided into four sections at action stations, with a dynamo supplying each section.

The electrical ring main, switchboard, and branch breakers were primarily located on the platform deck. The predicted extent of weapon damage to the platform deck included the switchboard room, No. 3 Breaker room, Cable Passages to the port and starboard side of the Forward Boiler Room and the Cable Passage to the starboard side of the Forward Engine Room. While damage was not predicted to No. 1 Breaker Room and No. 2 Breaker Room, it is predicted that two watertight sections aft of these breaker rooms were damaged, so it is likely that supply to these forward breaker rooms was cut.

Similarly, the supply to No. 4 Breaker Room was likely to have been cut as the Cable Passages on both port and starboard sides of the Forward Boiler Room are predicted as damaged. Emergency electrical power through bulkhead connectors in the forward section of the platform deck was also likely to be damaged. The equipment which takes supply from the electrical system in this area was likely to have been damaged from the torpedo hit, shell hits, and fire.

In summary, following the action with Kormoran, it is unlikely that any electrical equipment was operating forward of the machinery spaces.

The predicted damage to three of the four cable passages surrounding the forward machinery spaces on the platform decks makes it unlikely that any vertical rising branches from the mains in these passages were operational. This is also the case for the remaining undamaged cable passage to the port side of the forward engine room. The compartments above this cable passage (the engineers fitting shop and engineers workshop on lower deck) are predicted to have been damaged, which is likely to have affected any vertical rising branches from the mains in this passage. It is therefore unlikely that any electrical equipment above the forward machinery spaces was operational.

The predicted damage does not affect the supply of electrical power from each of the four dynamos to the aft section of the ship, although some reconfiguration of the system would be required for all of these dynamos to be supplying the aft.

Predicted damage to the upper deck and lower deck may have damaged electrical equipment and cable in these areas. This would have caused branch breakers (in Breaker rooms No. 5 and No. 6) or supply breakers (at the dynamos) to open. The damaged branch lines would need to be isolated if the supply breakers opened before the breakers could be closed. Emergency cables could be run to equipment if the supply cabling was damaged.

Lighting could be supplied by floodlights powered from emergency electrical cables and torches were probably distributed around the ship. It is unlikely that the ship was generally fitted with automatic emergency lighting.

The priority after damage would be to maintain electrical power to those systems required to control the ship and undertake damage control. This includes the running of dynamos, whether they are steam driven or diesel driven, and the distribution of electrical power through the ring main or emergency leads. Operation of the electrical system would require that changes to breakers be carried out at the location of the breaker, as central control at the Switchboard Room was lost.

Some fire and bilge pumps were probably operational, possibly by using emergency leads, providing fire fighting and pumping ability. This is dependent on the state of the main service, or firemain and the main suction line.

#### 7.6.2.6 *Trim*

In order to control the trim of the ship it would have been necessary to assess which compartments were flooded, and have this flooding controlled.

It is possible that the magazine spaces were purposely flooded so as not to have overheating of the munitions. The forward Small arms, 'A' Shell Room and 6" Shell magazines were likely to be open to the sea from the torpedo hit. Shell damage to the area around the No. 2 Flooding Cabinet on Forecastle, to the Lower and Platform deck would make it likely that the handwheels to the 4" Magazine and 'B' Shell room were inoperable. These compartments do not have seacocks within, so it would not have been possible to flood them on purpose. Although the No. 3 and 4 Flooding Cabinets were within fires, it is likely they or the alternate handwheels controls on the lower deck were operational when or if the fires receded, as shell damage to these aft areas was minimal. Thus it was possible to flood the magazine spaces aft of the machinery spaces.

#### 7.6.2.7 *Damage control constraints*

The modeling indicates that there would have been a very large number of casualties, on both the open decks and within the ship. The Lower deck is the main deck for egress between WTB, and contains the Damage Control Stations. Large shell hits, both port and starboard just aft of WTB 53 would have incapacitated DC1 which is forward of this WTB. Shell hits just below the Engineers Workshop (DC2) would cause some damage and some casualties within that compartment. As this DC Station was the main location

DSTO-GD-0559

for electrical and mechanical repair equipment and personnel, damage here would have serious repercussions to the DC capability of the ship. A shell hit aft of the Senior Officers Cabins on the upper deck would have caused fragment damage into the DC3 area below (Ward Room area and cabins). If the crew on DC duty were waiting in the DC areas for orders then there would have been many more casualties than if they were roving the lower decks in DC teams looking out for damage. However, there was so much damage to the forward half of *Sydney* that there would have been a significant number of casualties sustained by the DC crew.

With damage to large sections of the Lower deck, crew would have needed to go up to the upper deck at some locations in order to access the lower decks from a different location and avoid fires.

Although no shell hits were observed below the waterline, the Platform deck suffered the effects of the shell hits that penetrated the Lower deck. Compartments that were important to DC which were damaged include the Pump Lobby, Lower Steering Position (which also hosts the DCHQ) and Switchboard Room.

It is expected that the crew numbers in the Hold would have been intact. However, with the fire and shell damage to the above decks, escape routes would have been affected. This includes the magazines, boiler and engine spaces, and Transmitting station, and low and High Power rooms in the Hold.

#### 7.6.2.8 *Medical*

The analysis suggests that the Forecastle deck would have been either on fire or extensively filled with smoke so that evacuation would have been necessary. The major damage zone quickly engulfed the Forward Medical Distribution. Damage around the Ward Room and aft Medical Distribution Station was not as extensive and supplies were quite likely to be intact after the battle. However, a fire was alight on the deck above, if not also in the adjacent compartment, so smoke would have been a problem

#### 7.6.2.9 *After Action – Lifesaving Equipment*

After the engagement with *Kormoran*, the significant weapons or fragment effects would have resulted in considerable damage to the ship's boats and floats. Carley floats were normally held to the deck or to other structures with ropes or wire and during the engagement with *Kormoran*, it is highly likely that these ropes or wires could have been severed and the floats could have been blown overboard. Since there is no evidence of any Carley floats having survived on the seabed it is likely that they were severely damaged by fire, sunk, or were blown off during the engagement and then sank.

There was fire damage to many of the areas close to the Carley floats. For example, Figure 258 shows the Officers Galley and WCs on the port side at the aft end of the 4" gun deck. The Carley floats attached to the wood storage rack would have been close to this area and could have been affected by the fire.



Figure 258- Fire damage to the port side aft upper deck in the vicinity of the 4" gun deck [254, 312]

Carley floats were not designed to survive significant weapons effects and it is highly likely that due to the extensive weapons damage on the upper decks, most of them would have been severely damaged. Since the inner tube of the Carley float was constructed of thin sheet metal (either copper or galvanized steel), if the Carley float sank, the inner tube would have corroded relatively quickly and left behind little identifiable debris.

It is interesting to note that a Carley float with the number 5 on it would have been located at the stern on the starboard side on *Sydney*. An examination of the weapons damage on the Pattern No. 20 Carley float found by *Heros* shows significant fragment damage that is believed to be "due to at least one HE shell detonating on or near the main structure of the ship and ricocheting into the float [113]. The float also shows no exterior burn marks or evidence of exposure to heat [113]. Given the limited weapons damage and fires on or around the stern of *Sydney*, it is possible that the Carley float was from *Sydney*. However, as noted earlier, there is no photographic evidence that has been found that shows that after 1935, the Carley floats of *Sydney* were numbered. It is therefore impossible to say with any certainty that the Carley float found by *Heros* was originally from *Sydney*.

The ship's boats were also subject to significant weapons damage which would have precluded their use for any lifesaving or evacuation purposes. The ship's crane was damaged and it would not have been possible to get the boats off board. The Cutters almost certainly fell off during the encounter as their davits were destroyed by shell fire. There is an extremely high probability that they sank at the site of the engagement.

#### 7.6.2.10 Communications

The aerials for Wireless Telegraphy were strung between and on the two masts and spars. With *Kormoran's* early shell hits on the Bridge superstructure, it is expected that the Forward Mast would be damaged. The aft mast and associated aerials connected to the Aft DC Tower may have survived longer, but it is likely that aerial cables could have

DSTO-GD-0559

broken during the battle. When the torpedo hit, the shock to the ship structure could have resulted in damage to the masts and aerals.

In 1942 HMS Liverpool [286] was hit by a torpedo abreast the aft engine. The main W/T aerial broke from whipping, and the radar or HACS were lost. In 1943 HMS Birmingham was hit forward by a torpedo. This broke the main aerial legs and W/T was out temporarily, until jury rigged. However, in 1940 HMS Liverpool was struck on the bow by a torpedo, with fire damage to 'A' turret. There was no mention of communications/aerial problems. Hence, although jury rigging of aerals is a standard practice, given the extensive damage and the high number of casualties on *Sydney* it is unlikely that jury rigging was carried out.

#### 7.6.2.11 After the battle

The ROV footage, modelling and analysis indicate that *Sydney* was severely damaged during the encounter with Kormoran. Shell hits to the forward Superstructure decks and decks below ignited several fires. The smoke from these fires would have spread throughout the forward section of the ship through damage holes in decks, bulkheads and damaged ventilation trunking. The smoke was probably also drawn into the forward boiler room and forward engine room due to their air intakes being close to the forward superstructure.

The forward boiler room and forward engine room were also damaged by shell fire, and were probably evacuated and the machinery shut down. The after boiler room and engine room would then have been used to supply propulsion, electrical generation and fire and bilge pump services.

Smoke would have caused difficulties in these spaces, but they could not be abandoned as they supplied services necessary for damage control and fire fighting and to control the ship.

The two diesel dynamos, external to the aft boiler room, were probably available for electrical supply. The electrical distribution system would have been damaged forward of the forward boiler room, above the forward boiler room and forward engine room. Due to the physical damage to these areas, and casualties suffered, it is unlikely that electrical power was restored in these areas by use of emergency leads.

The area of the ship shaded in light grey in Figure 259 was structurally intact. However the services in this area would have been deleteriously affected by the damage sustained in the remainder of the ship. The impacted systems in the light grey area probably included the electrical branch lines and equipment, which could have caused disruptions to the main electrical supply, requiring the isolation of some of the branch lines. It is possible that emergency leads were run to some equipment, or used as the main supply if damage to permanent cabling was too severe.

Damage to the main service was similar to that of the electrical system, which would have caused fire fighting options to be limited to the fires midships (below the aircraft catapult) and the aft superstructure. The fire in the forward superstructure is unlikely to have been fought. Consequently it would have been able to spread below decks. The openings in the hull from shell penetrations would have provided a source of oxygen.



DSTO-GD-0559

As can be seen from an examination of Figure 259 it is highly unlikely that any damage control was carried out in the forward section of *Sydney*.

A summary of the damage sustained and the impact on the firemain and ventilation systems is shown in Figure 259.

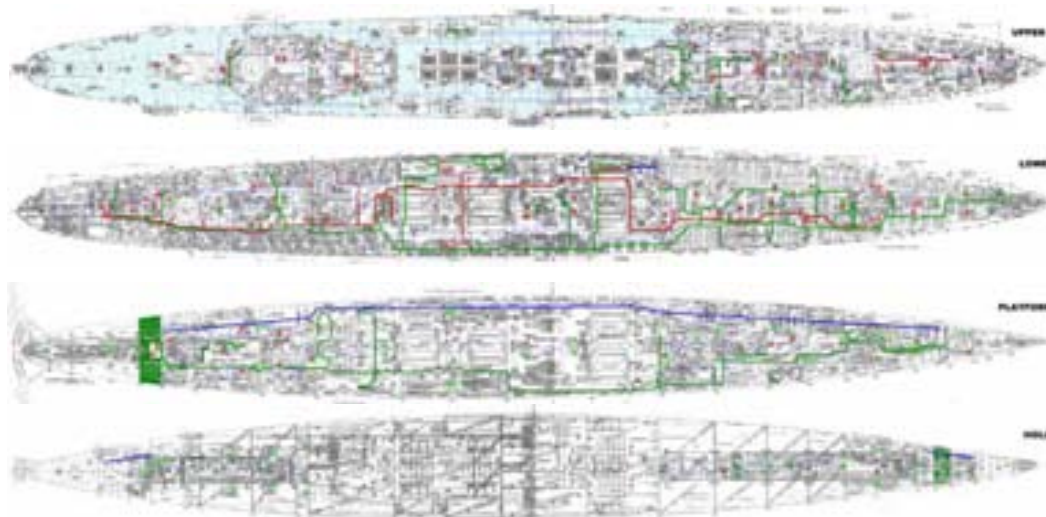

*Fresh Water Service is indicated in green (the hot water is not shown); the Fresh Water Tanks are also marked in green. The thick red line indicates the saltwater or Main Service, and the thinner red line is the small bore feed to sanitary spaces. The Main Suction is indicated with blue lines.*

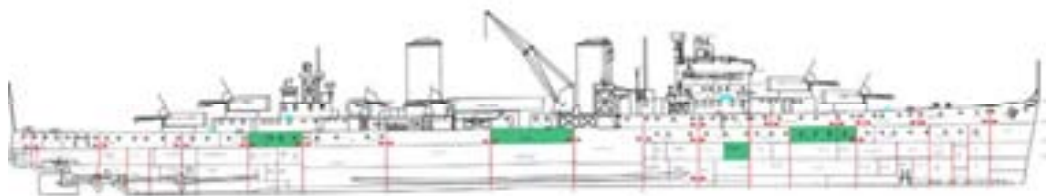

*Profile of Sydney showing the DC Stations in green, and the WTB in purple, with horizontal arrows indicating where passage is available across WTBs.*

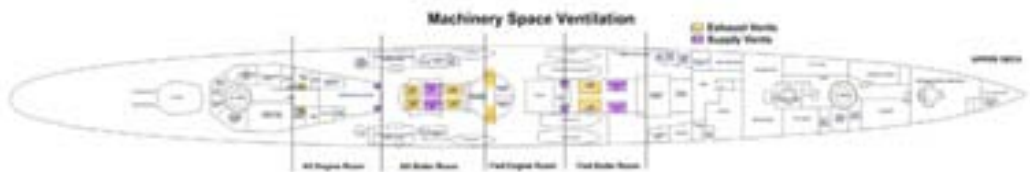

*The ventilation supply and exhausts vents on upper deck.*

DSTO-GD-0559

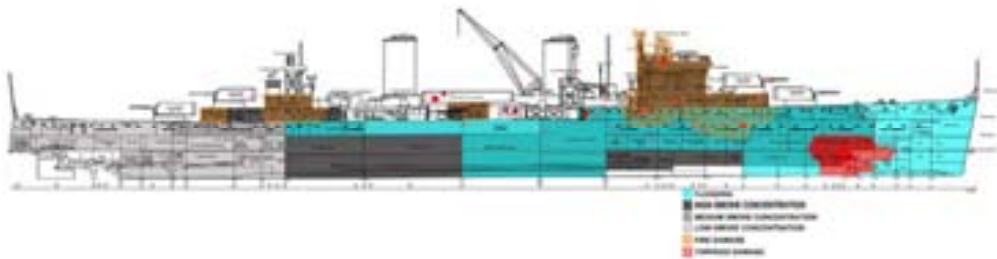

*Port side total damage profile prior to sinking.*

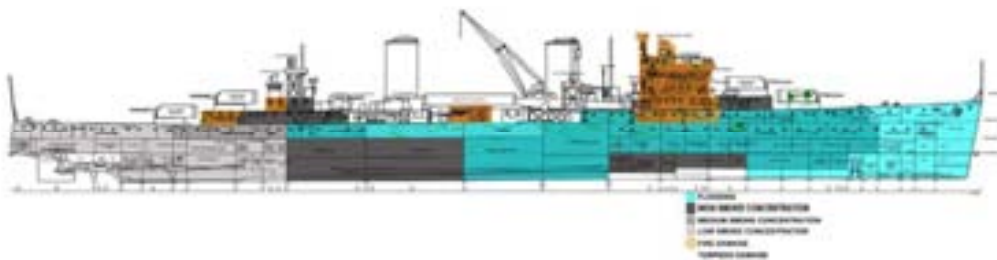

*Starboard side total damage profile prior to sinking.*

*Figure 259: Systems and composite damage extents after the battle*

The surviving able bodied crew were likely to have been attempting to control the ship from the machinery spaces and steering compartments, provide electrical and fire fighting services, as well as assisting and treating the injured. While the ship was afloat and some limited control maintained it would provide a greater chance of survival.

## **7.7 The Loss of Sydney**

This section of the report provides an analysis of why *Sydney* finally sank.

### **7.7.1 Structural Integrity**

#### *7.7.1.1 Analysis of Longitudinal Strength*

##### **7.7.1.1.1 Introduction**

The aim of the longitudinal strength structural analysis was to determine whether the ultimate strength of the ship's structure was sufficient to prevent the bow section tearing away from the main hull, after battle damage, while the ship was still floating. The approach taken to perform the analysis was to compare the forces due to the wave loads acting on *Sydney*, with the strength of the damaged hull structure. If the residual ultimate strength of the ship's structure is greater than the responses due to the sea loads, it follows that the bow section would remain attached to the main hull whilst the ship is on the sea surface. Once the ship sinks below the sea surface, the theory used in the following analyses is no longer valid and no further conclusions can be drawn using this approach.

This form of analysis is a deterministic or static approach [21] and was undertaken using state-of-the-art software codes. A deterministic analysis is currently the most common method of rapidly analysing damaged ship structures [313]. The analysis consisted of three parts:

- i. Calculation of the sea loads acting on *Sydney* after the battle with *Kormoran*.
- ii. Calculation of the ultimate strength of the section damaged by the torpedo hit
- iii. Comparison of the results from i. and ii.

#### 7.7.1.1.2 Sea Loads

To replicate the damage, a mesh was created with *Sydney* floating at a damaged displacement and trim of 2.79 metres by the bow. This mesh was used to calculate the sea loads acting on *Sydney* after the battle.

The seaway conditions after the battle were input using the JONSWAP sea spectra for coastal waters and the World Meteorological Organisation's standard parameters that represent the sea states three and four, as given in Chapter 7. Other, higher sea states were also analysed to obtain an overall picture of the structural loading of *Sydney* in the later comparison of the sea load and ultimate strength results. The model was analysed in headseas, which is the heading that will correspond to the highest longitudinal loading of the ship's structure, at a ship speed of 5 knots, which was given by Olson from German survivor accounts [74].

#### 7.7.1.1.3 Ultimate Strength

ROV footage analysis identified that there was visible damage caused by a torpedo hit on *Sydney* at approximately frame 27. In order to investigate the circumstances surrounding the separation of the bow section from the main hull at this frame, the ultimate hull girder strength of the frame, subjected to various levels of damage, was performed using the Ultimate Strength (ULTSTR) computer software.

Ultimate strength analyses of *Sydney* hull girder at frame 27 were then performed at a range of damaged conditions. These were carried out in order to investigate the level of damage at this location to cause a catastrophic failure leading to the separation of the bow section from the main hull of the vessel. The damaged conditions ranged from completely intact, to just over two thirds of the structure within frame 27 removed due to torpedo damage (asymmetric case). As there is uncertainty surrounding which damage to *Sydney* was caused by the battle and which damage was caused by sinking over two kilometers in the ocean, structure was removed from an initially assumed position below the waterline on the port side of the ship and then expanded in increasing radii. An example plot of the strength versus curvature of the intact frame 27 and a case where 47% of the structure has been removed due to damage, is shown in Figure 260. As can be seen from Figure 260 the ultimate strength of the intact section is greater overall than the ultimate strength of the damage section. A further investigation was performed where the structure was removed one deck level at a time, starting from the keel (symmetric case).

DSTO-GD-0559

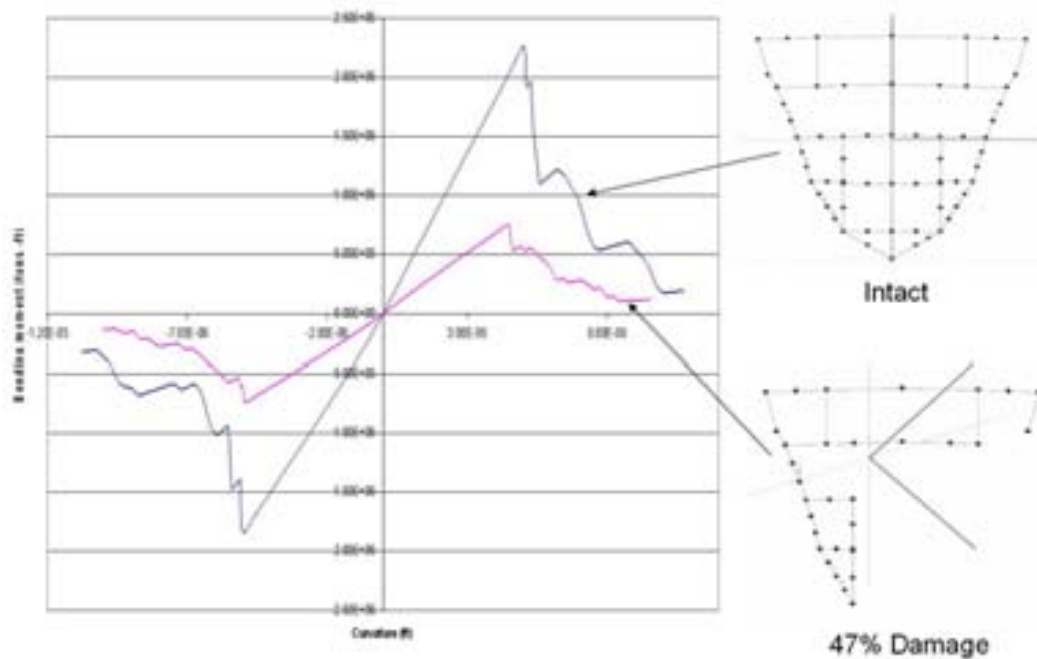

Figure 260: Comparison of Ultimate strength curves for frame 27 intact and frame 27 with 47% of structure removed due to damage

#### 7.7.1.1.4 Comparison of Sea Loads and Ultimate Strength

To account for uncertainties, such as the application of theory developed for welded plates being used in the analysis of a primarily riveted vessel, a reduced ultimate strength capacity of frame 27, created by multiplying the calculated value by 0.75, is included. After reviewing literature on the ultimate strength of riveted ships [25], the 0.75 factor of safety applied to the ultimate strength calculated using ULSTR, is considered more than satisfactory. Plots of the ultimate strength of frame 27 versus the percentage of structure removed due to damage, along with the bending moments at frame 27 due to sea loads, are shown in Figure 261, for the asymmetric damage case, and Figure 262, for the symmetric damage case.

From the plots in Figure 261 and Figure 262, it can be seen that for both the asymmetric and symmetric damage cases, the ultimate strength of the section remains greater than the sea loads in sea states three and four, for even the most extensive damage. The bending moments for sea states six and eight have been included as a guide to the level of residual ultimate strength of the section at frame 27.

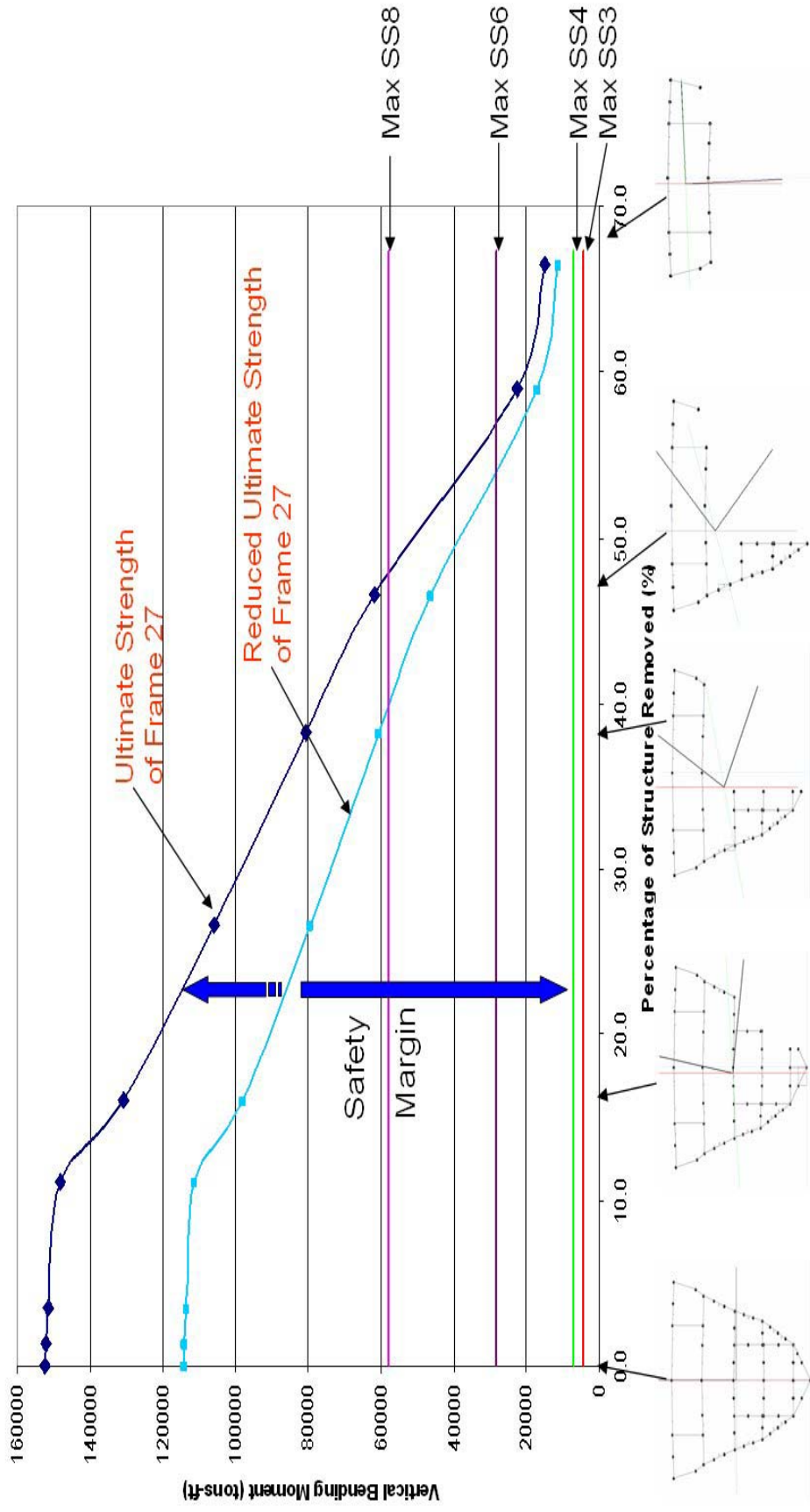

Figure 261: Comparison of Ultimate Bending Strength and Bending Moments due to Sea Loads at Frame 27 for Asymmetric Damage

*This page intentionally blank*

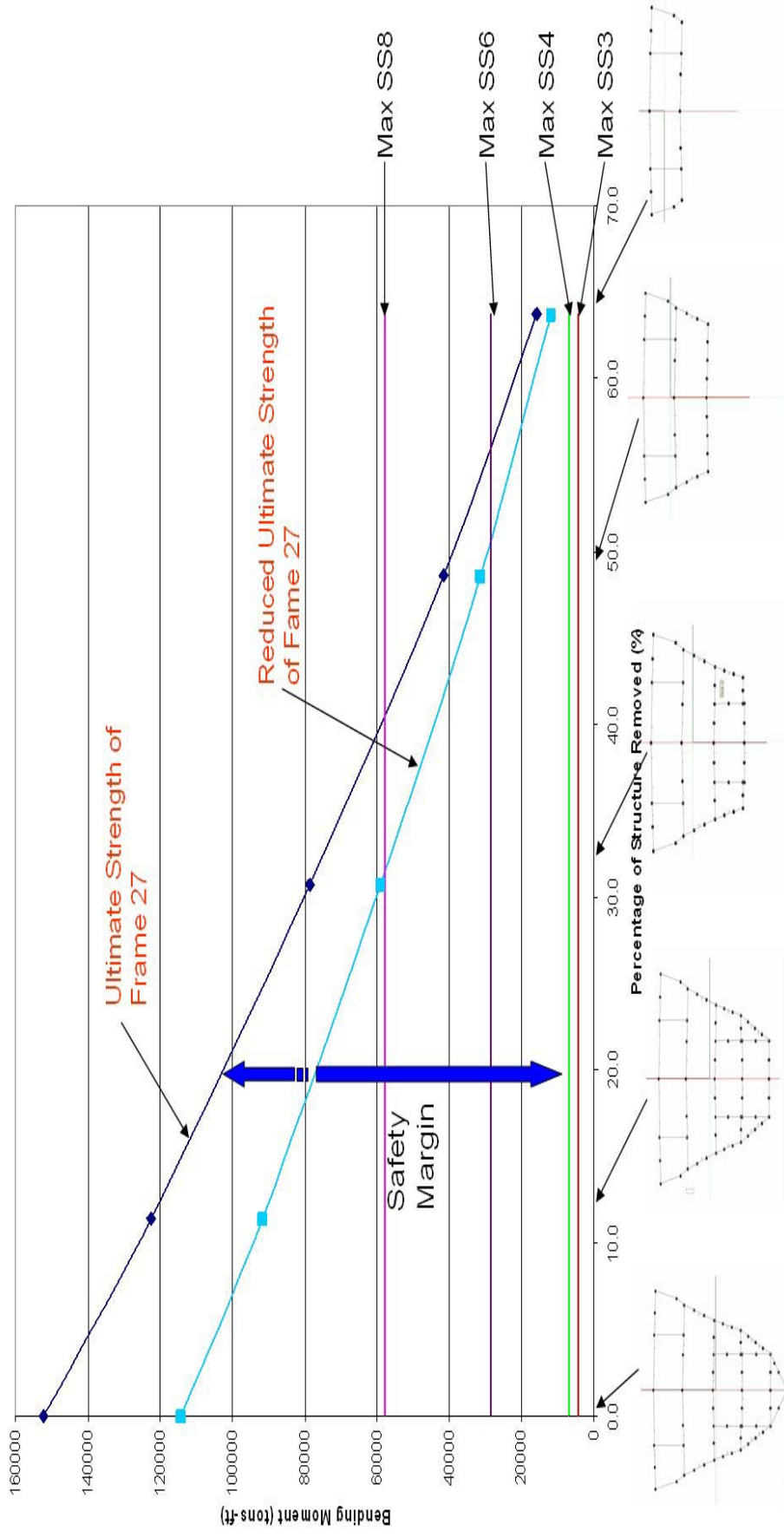

Figure 262: Comparison of Ultimate Bending Strength and Bending Moments due to Sea Loads at Frame 27 for Symmetric Damage

*This page intentionally blank*



#### 7.7.1.1.5 Conclusion

It is highly unlikely that the bow section detached while *Sydney* was still floating on the sea surface.

### 7.7.1.2 Watertight Bulkhead Strength

#### 7.7.1.2.1 Introduction

A second structural analysis was performed with the aim of investigating the possibility of structural failure of the watertight bulkheads on board *Sydney*. This failure would be due to the hydrostatic pressure caused by flooding of compartments on one side of the bulkhead, leading to loads on the bulkhead greater than the load carrying capacity of the steel bulkhead structure. The transverse watertight bulkheads in a ship are the most effective method of subdividing the vessel into watertight compartments. These compartments provide protection against overwhelming flooding of the vessel by restricting the internal volume of the ship that can be flooded. The failure of watertight bulkheads will cause unchecked flooding of the ship, which can lead to sinking by foundering [21]. The analysis of the strength of the watertight bulkheads on board *Sydney* took the form of a literature review and subsequent calculations.

#### 7.7.1.2.2 Literature Review

The literature review was conducted in order to investigate the philosophies used by Naval Architects at the time *Sydney* was being designed. Two references in particular [314] and [315] gave excellent insight to the approach taken when designing watertight bulkheads at the time. On the subject of watertight bulkhead stress analysis theory, one of the references states; "...it will be found that the general stress level is high based on the simple theory outlined. This high stress level is reasonable in view of the fact that such bulkheads are only required to carry the loads on which the calculations are based in an emergency" [314]. Further, "In some cases it will be found that on the basis of the simple theory, the stresses are beyond the elastic limit of the material..." Based on these statements, it can be seen that the approach to designing watertight bulkheads at the time, was to use the bare minimum scantlings for watertight bulkheads. This implies that in the event of flooding on one side of a watertight bulkhead, damage to the steel structure would be significant and permanent, to the extent that repairs would be required.

The paper by King [315] describes a set of experiments where a cofferdam was constructed using walls that embody the approach used by dockyards at the time to construct watertight bulkheads. This cofferdam was filled with water and observations of damage and deflections recorded. The descriptions of damage to the bulkhead due to hydrostatic pressure state; "The permanent set was considerable, and there was evidence that most of the stiffeners had begun to fall away from their work..." Also, "...the chief disturbance consisted in the pulling away of the brackets of the smaller stiffeners from the deck plating" [315]. This damage is significant and suggests that the bulkhead loading was close to its ultimate strength. The paper also describes water leakage because of the deflections caused by the hydrostatic pressure, "...the rivet

DSTO-GD-0559

connections of the heel brackets to the tank top began to leak at an early stage of filling..." [315].

While the work covered in [314] and [315] infer that significant deflections and damage will occur to watertight bulkheads when a ship compartment floods, the added effect of damage to the bulkhead structure was not considered. After the battle with *Kormoran*, it could be assumed that many of the watertight bulkheads on board *Sydney* had damage such as holes and cracks in the plating and stiffeners due to shrapnel etc. These holes and cracks can cause stress concentrations in the structure, thus further increasing local stresses. In plating for example, an elliptical hole can increase the local stress by as much as three or four times the uniform stress in an undamaged plate [316].

### 7.7.1.2.3 Analysis

Muckle [314], proposes a simplified method of analysing stresses in watertight bulkheads in a flooded compartment based on beam theory. The bending moment along the height of the bulkhead is given by ..... 1;

$$M = -wS \left[ \frac{x^3}{6} + \frac{hx^2}{2} - \left( \frac{3l^2}{20} + \frac{hl}{2} \right) x + \frac{l^2}{30} + \frac{hl^2}{2} \right] \dots\dots 1$$

Where the variables are defined in Figure 263 as;

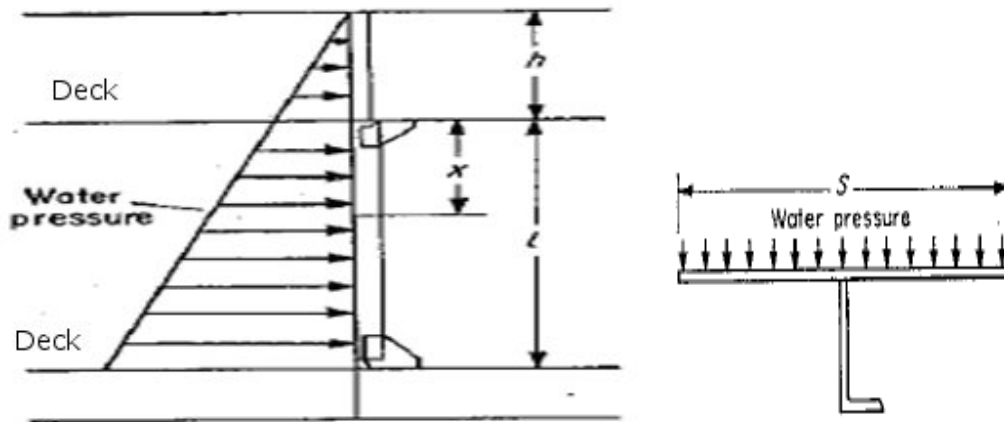

Figure 263: Definition of Variables for use in Equation 1 [314], where  $w$  is the water pressure.

An analysis was performed on the watertight bulkhead at frame 53 due to the assumption that all watertight bulkheads forward of this frame were no longer intact after the torpedo had hit. The Modified Leander Class Transverse Bulkheads 35 and 73 drawing [317] was used to identify the plating thicknesses and stiffener scantlings and arrangement of the watertight panel in the bulkhead most susceptible to failure. These scantlings were assumed to apply for the watertight bulkhead at frame 53 due to the presence of similar arrangements on the deck plans of the platform [4] and lower decks [3] at the bulkhead located at frame 35. The bulkhead panel that was analysed had seven pound plating (4.45mm thick) with 3 1/2" by 1/4" flat bar stiffeners spaced at 2'. However, in the analysis, this stiffener spacing was doubled due to the lack of bracketing on every

second stiffener. The height of the panel was the height between the platform and lower decks and the width of the panel the distance between the longitudinal bulkheads either side of the ship’s centreline. The bending stress in the bulkhead was calculated using the moment calculated from ..... 1 in the formula for beam theory given in 2, where  $\sigma$  is the stress,  $M$  is the applied bending moment,  $y$  is the distance from the neutral axis to the extreme fibre and  $I$  is the second moment of area.

$$\sigma = \frac{My}{I} \dots\dots\dots 2$$

This analysis does not consider the additional strength that may have been provided by any shoring of bulkheads performed by the crew.

The calculated bending stress along the height of the bulkhead is plotted in Figure 264 for a zero metre head of water above the lower deck, i.e. the compartment is flooded to the height of the lower deck. Also on the plot are the yield and ultimate strengths of D grade steel of 205 and 415 MPa respectively [318].

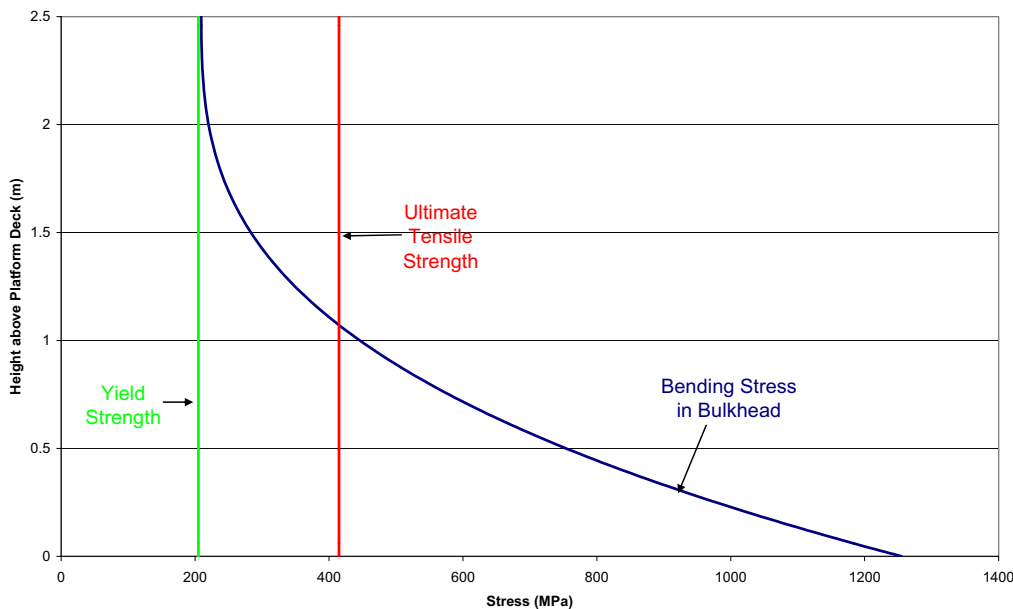

Figure 264: Bending Stress along Height of Bulkhead at Frame 53 along with Ultimate and Yield Strengths of D grade Steel

From Figure 264 it can be seen that the bending stress in the bulkhead is greater than the yield strength of the steel over the entire height of the bulkhead panel analysed. It should be noted however, that this simplified approach tends to overestimate the stress in the bulkhead at the upper and lower edges, and that it is likely that the maximum stress in the bulkhead will be at approximately mid height [314]. At the midpoint of the bulkhead panel, from Figure 264 it can be seen that the bending stress is well into the plastic region of the steel material. This is consistent with the literature that was reviewed in the previous section.

DSTO-GD-0559

#### 7.7.1.2.4 Conclusions

The literature review and subsequent analysis have identified that watertight bulkhead design philosophies in the early 20<sup>th</sup> century favoured minimal scantlings due to watertight bulkheads being a survival mechanism so that the ship could return to port for repairs after flooding.

Any significant flooding of compartments on one side of a watertight bulkhead designed using this philosophy would have undergone significant plastic deformation, although still remaining watertight.

If any damage, such as holes or cracks, was present in a watertight bulkhead structure designed using this philosophy, stress concentrations would have caused increased local loadings on the structure and caused catastrophic failure.

### 7.7.2 Time to flood

The aim of this analysis was to determine the duration that *Sydney* remained afloat after sustaining damage.

#### 7.7.2.1 Damage Extents

Damage locations and sizes are based on the damage identified in this chapter and in Appendix A.1.

#### 7.7.2.2 Assumptions

##### 7.7.2.2.1 Sea States

It has been reported [74, 283] that on the 19<sup>th</sup> November 1941 at 1200 hrs the sea state was a medium swell from the south west with a sea state 3. Between 1925 hrs and 2200 hrs *Kormoran* lowered their lifeboats and the sea state was reported to be between sea state 3 and 4 and deteriorating [74, 283].

For the analysis of the progressive flooding of *Sydney*, it has been assumed that the wave environment would have been either the top of sea state 3 or the top of sea state 4. The stability of *Sydney* operating in both these environments has been analysed. A Jonswap spectrum with a gamma of 3.3 has been used. This is typical of the spectrum that would be observed in this sea area. The significant wave height,  $H_{sig}$ , and wave periods for each of the sea states are based on those from the DEF(Aust) 5000 [319]. These values are shown in Table 25.

Table 25 Seaway Descriptions

| Sea State | $H_{sig}$ (m) | Mean Wave Period (sec) |
|-----------|---------------|------------------------|
| 3         | 1.25          | 7.40                   |
| 4         | 2.50          | 8.60                   |

##### 7.7.2.2.2 Speeds

The wreck of *Kormoran* was found at Latitude of 26° 5' 49" S and a longitude of 111° 4' 27" E and it is assumed that this is the vicinity of the location that the battle took place. The wreck of *Sydney* was discovered at Latitude of 26° 14' 37" S and a longitude of 111° 13' 3" E [133]. The distance between these two wreck sites equates to 21.7 km. It has been reported that the "glow" from the fires on *Sydney* were no longer visible after 2300 hrs [283], which is approximately 4.5 hours after the start of the battle. If *Sydney* was to travel 21.7 km in 4 hours she would have had to travel at an average speed of 2.9 knots (5.4 km/hr) assuming constant speed. It is believed that as time progressed, *Sydney* would have taken on more water due to flooding through damage openings. This increase in the flooding will affect the ship's capability to maintain speed. It is therefore assumed that throughout this 4 hour period that *Sydney* travelled at an average speed of 5 knots.

#### 7.7.2.2.3 Headings

Assuming that *Sydney* travelled in a straight line from the approximate battle location to the site where the wreck of *Sydney* was found, then *Sydney* would have been travelling in a south easterly direction. This is consistent with reports stated in the list of assumptions [283]. A review of meteorological data of this location for the period of 17-28 November 1941 [320] indicates that the direction of the swell was south to south west. It is therefore believed that after the battle *Sydney* sailed off in beam seas. In this analysis, a range of headings have been considered varying from 0 to 360° in 30° increments.

#### 7.7.2.2.4 Durations

All simulations in this analysis were undertaken for 12 hours after the damage to *Sydney* was inflicted.

#### 7.7.2.3 Analysis

Simulations were undertaken considering two damage scenarios

- (Scenario 1) Flooding only occurred through holes in hull observed from the analysis of the ROV footage. All internal compartment geometry was assumed to be intact except for the area which experienced torpedo damage. This simulates the ship at action stations. This scenario is described as 'damage to hull structure only.'
- (Scenario 2) Analysis has been undertaken as to the fragmentation and blast damage resulting from some of the munitions detonating internally. The flooding analysis in this scenario considers flooding due to the torpedo damage, through the penetrations in the hull and through the predicted internal damage. This scenario is described as 'observed and predicted internal damage.'

Figure 265 to Figure 269 show the compartments that could potentially be flooded at some stage prior to the loss of *Sydney* due to the observed and predicted damage resulting from penetrations. Some of these penetrations are initially above the waterline

DSTO-GD-0559

but as the forward section floods, the vessel trims by the bow and starts to heel over. When this occurs some of these penetrations will become submerged. Other penetrations only become submerged when waves pass over them and this will be dependent on sea state, headings and the flooded condition of the ship.

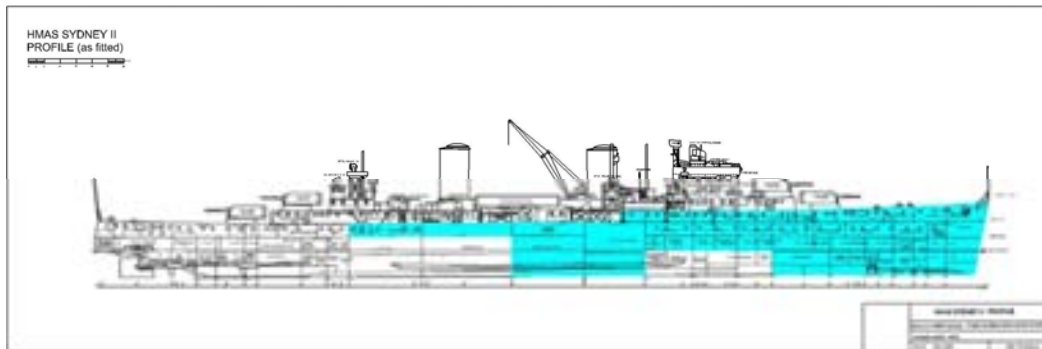

Figure 265 Profile of Sydney showing potentially flooded compartments due to weapons damage

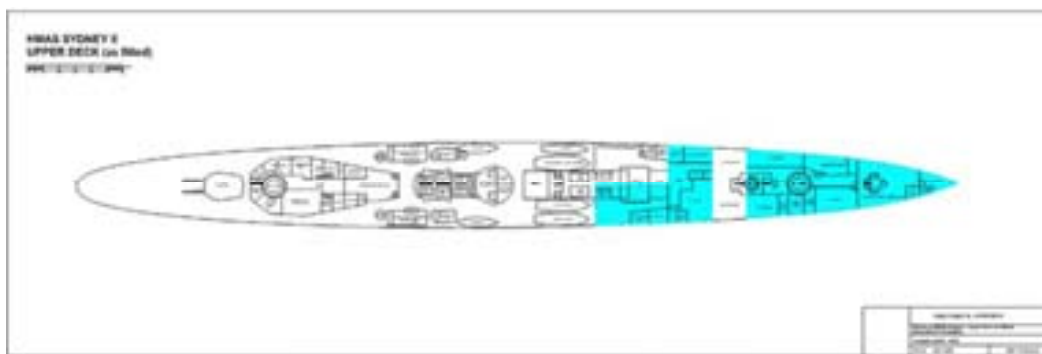

Figure 266 Upper Deck of Sydney showing potentially flooded compartments due to weapons damage

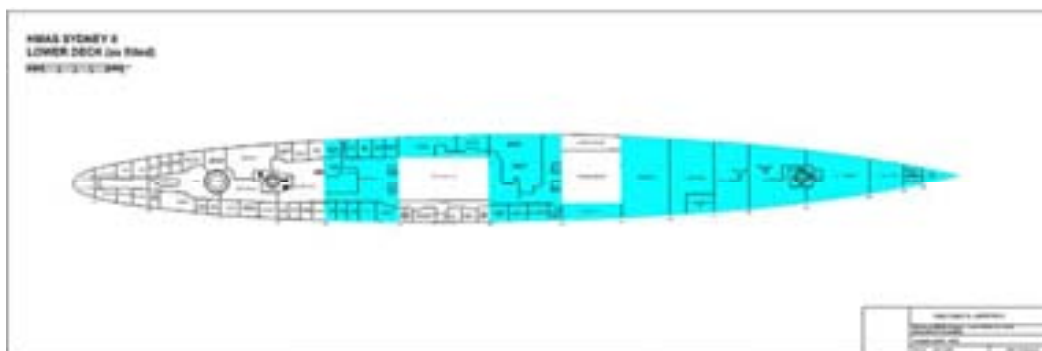

Figure 267 Lower Deck of Sydney showing potentially flooded compartments due to weapons damage

DSTO-GD-0559

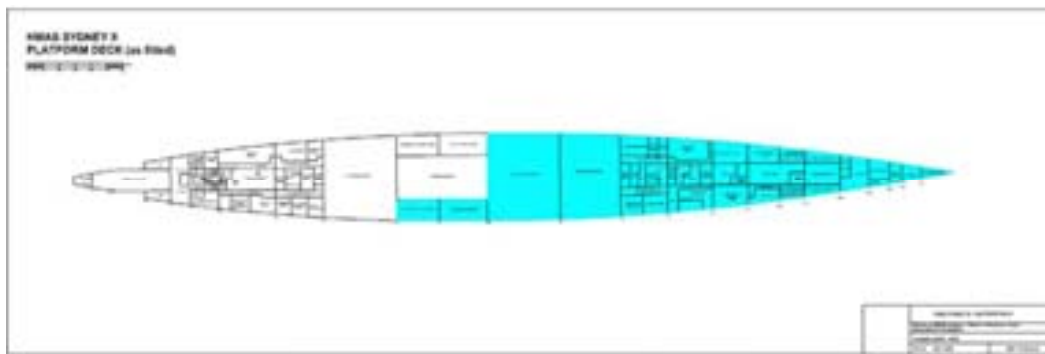

Figure 268 Platform Deck of Sydney showing potentially flooded compartments due to weapons damage

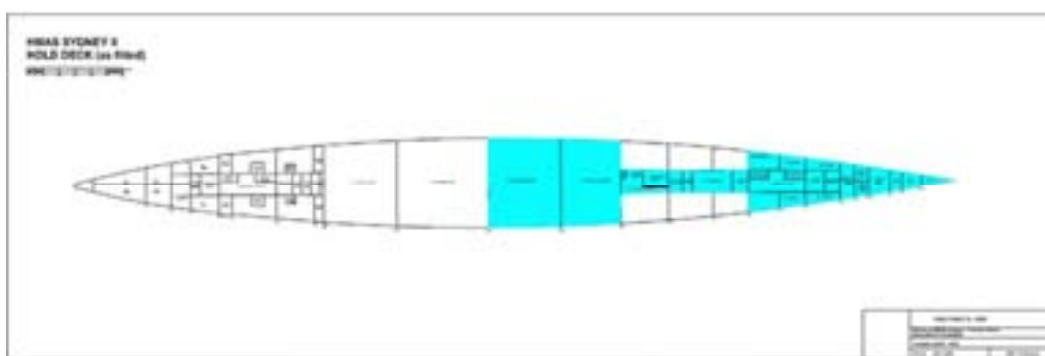

Figure 269 Hold of Sydney showing potentially flooded compartments due to weapons damage

#### 7.7.2.4 Results

##### 7.7.2.4.1 Scenario 1 - Damage to Hull Structure Only

The analysis considered the progressive flooding that may have taken place through the penetrations in the hull as observed with the ROV.

Figure 270 shows a polar plot indicating that with the damage extents described above *Sydney* potentially could have remained afloat for at least 12 hours independent of the headings she sailed. These results are based on the assumptions that the wave environment was sea state 3 and that *Sydney* was sailing at a speed of 5 knots.

DSTO-GD-0559

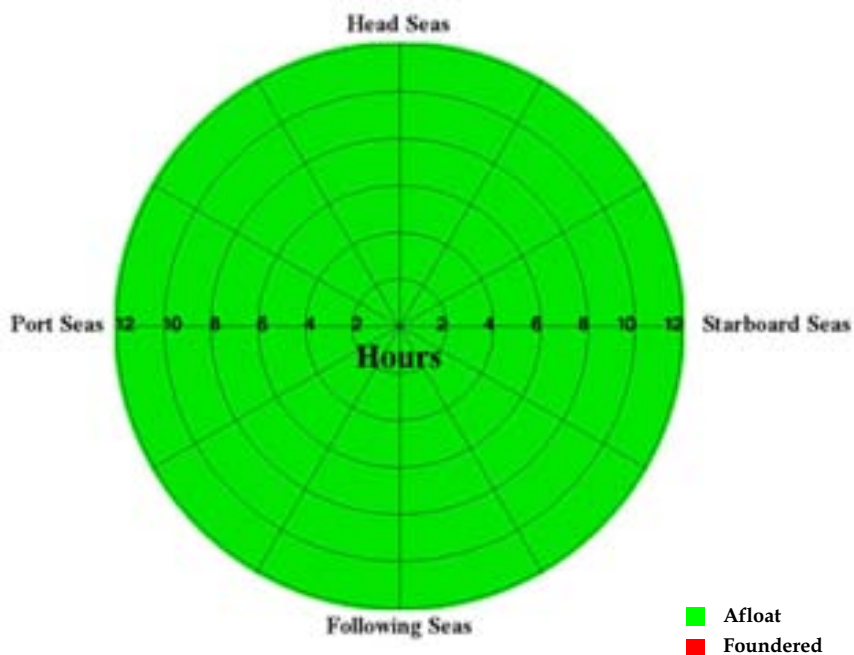

Figure 270 Polar plot indicating time Sydney remained afloat in Sea State 3 considering flooding through hull penetrations and torpedo damage only

Although remaining afloat, the time history for the roll of the vessel sailing in beam seas, as shown in Figure 271, indicates that after approximately 4 hours from the battle the vessel may have been constantly rolling between approximately 15° and 40° to port. Any attempt at damage control and/or evacuation at these large roll angles would have been virtually impossible.

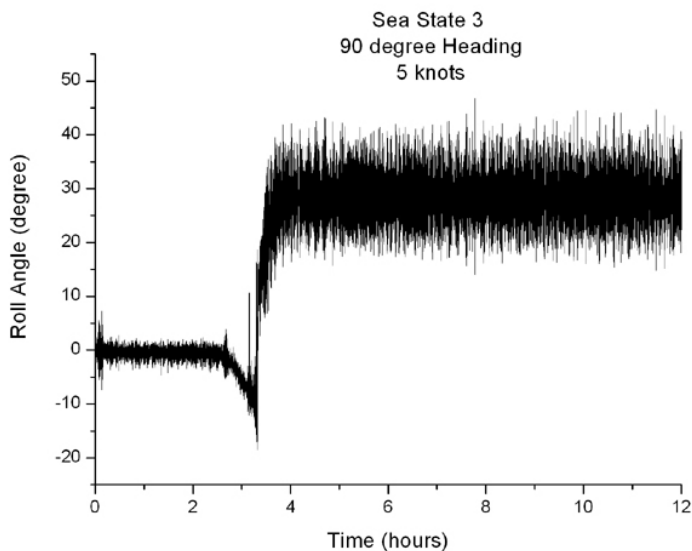

Figure 271 Time record for the roll motion of Sydney in Sea State 3 considering flooding through hull penetrations and torpedo damage only



Figure 272, shows a visualisation of *Sydney* at a roll angle of 40° to port in sea state 3.



Figure 272 Visualisation of *Sydney* at a roll angle of approximately 40° in Sea State 3

It was reported that when *Kormoran* launched their lifeboats that the sea state was increasing to sea state 4 and getting worse [283]. Figure 273 shows that even with a worse sea state, if *Sydney* was sailing in a 60° or 120° heading then potentially she may have remained afloat for at least 12 hours. It is believed that after the battle *Sydney* sailed off in approximately beam seas (90° heading). Any slight deviation in heading from 60° or 120° would have significantly changed the time the vessel remained afloat. For the damage extents considered, the analysis indicates that for all other headings considered, the time after the battle that *Sydney* could potentially remain afloat was somewhere between 2 to 4.5 hours. This is consistent with reports that the glow on the horizon from the fires onboard *Sydney* disappeared approximately 4.5 hours after the battle [283]. If Figure 270 and Figure 273 are compared it is evident that the change in sea state alone had a significant effect upon the survival time of *Sydney*.

DSTO-GD-0559

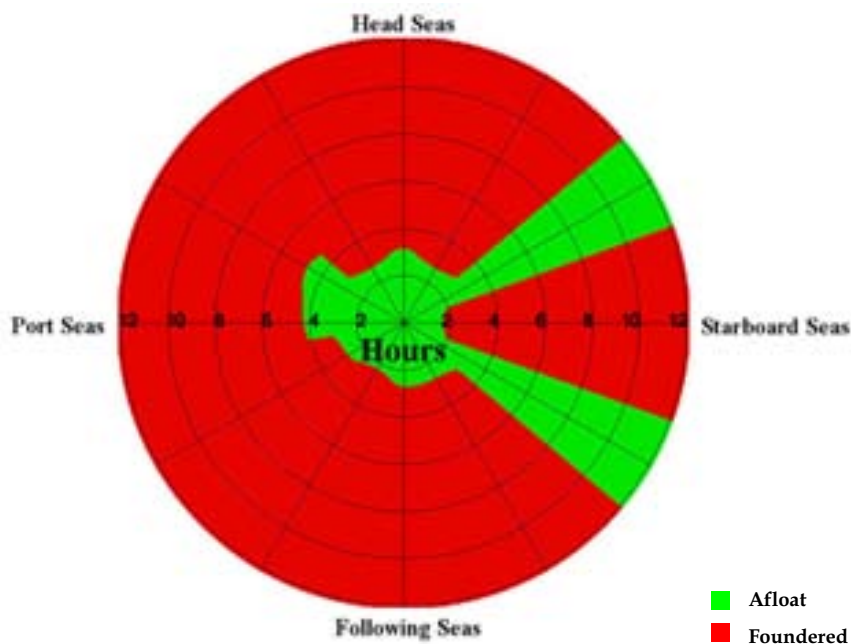

Figure 273 Polar plot indicating time Sydney remained afloat in Sea State 4 considering flooding through hull penetrations and torpedo damage only

#### 7.7.2.4.2 Scenario 2 - Observed and Predicted Damage

In this analysis additional damage due to the fragmentation and blast damage resulting from some of the munitions detonating internally has been considered. This additional internal damage will allow the progressive flooding to occur between adjacent compartments where there has been damage to the bulkheads, deck or deckheads. The damage can be either entire panels missing or holes in the bulkheads etc through which the floodwaters can move. Other damage that would have occurred internally is the damage to doors and hatches. Although this would also contribute to flooding process of *Sydney* this has not been considered at this stage.

Figure 274 shows the predicted times that *Sydney* remained afloat in sea state 3 when the internal damage was considered. It can be seen, depending upon the heading that *Sydney* was sailing, that the survival time of the vessel varies. If Figure 270 and Figure 274 are compared it is evident that this additional damage significantly effects the duration which *Sydney* remained afloat.

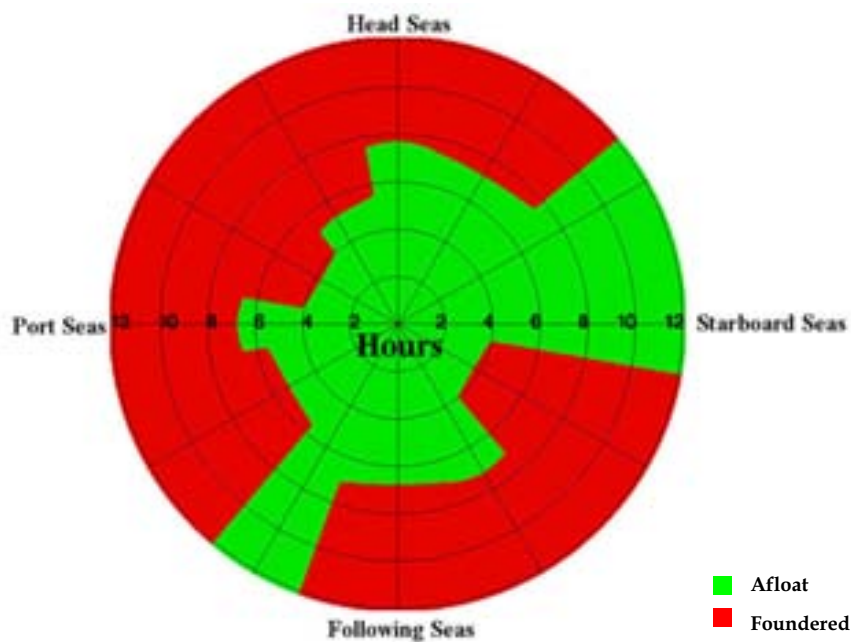

Figure 274 Polar plot indicating time Sydney remained afloat in Sea State 3 considering flooding through hull penetrations, torpedo damage and predicted internal damage.

Figure 275 shows the predicted time that Sydney remained afloat as the seas increased to sea state 4. It is evident that regardless of the heading of Sydney the vessel potentially would have sunk after 2 to 4 hours.

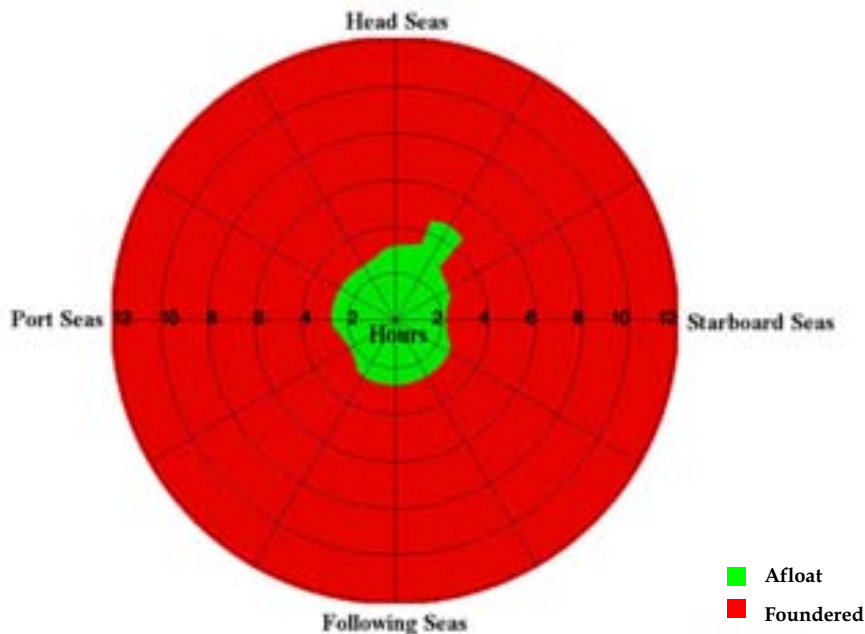

Figure 275. Polar plot indicating time Sydney remained afloat in Sea State 4 considering flooding through hull penetrations, torpedo damage and predicted internal damage.

DSTO-GD-0559

### 7.7.2.5 Conclusion

The analysis of the torpedo damage to *Sydney* has indicated that flooding to the forward sections back as far as approximately 48 m from the Forward Perpendicular would not have resulted in the loss of the vessel. The vessel would have trimmed down by the bow but still had sufficient buoyancy to remain afloat.

It is reported that at the time of the battle the wave environment was sea state 3. Apart from the torpedo strike most of the damage observed with the ROV was shown to be above the waterline. As the vessel trimmed, due to the flooding in the forward sections, some of these penetrations became immersed and subsequently allowed the water to flood into spaces. As the sea state deteriorated more of the penetrations would have become below the waterline. The analysis has shown that if the wave environment remained at sea state 3 then *Sydney* may have remained afloat for at least a period of between 4 and 12 hours. This is dependent upon the ship's heading. Although afloat, in certain circumstances the vessel would have been rolling to the extent that any damage control procedures and/or evacuation would have been virtually impossible.

As the seas deteriorated, the duration of the vessel remaining afloat reduced. In both scenarios considered, the time before the event that led to the loss of *Sydney* was approximately between 2 and 4.5 hours. There are several contributing factors that may have led to the final sinking of the vessel. It has been shown that after the battle *Sydney* would have experienced significant roll motion. Over time the amplitude of this roll would have increased due to an increase in both the flooding and sea state. As the roll increased the vessel would have started to experience deck edge immersion and additional flooding of the vessel may have occurred through other openings. Eventually the ship may have rolled to an angle beyond which she could not have recovered, losing any remaining buoyancy and eventually sinking. Another contributing factor that may have led to the loss of *Sydney* is the possibility of the collapse of water tight bulkheads. This phenomenon has previously been discussed. If this failure mechanism occurred it would have resulted in flooding to additional parts of the ship, affecting the trim and possibly the stability of the vessel. As there is no evidence to determine if this failure occurred, it has not been considered in this analysis.

### 7.7.3 Final Demise

The process of foundering (loss of) *Sydney* is difficult to determine exactly however there is a probable scenario which is highly likely. The remainder of this section describes what is believed to be the most probable. The process followed is shown in Figure 276.

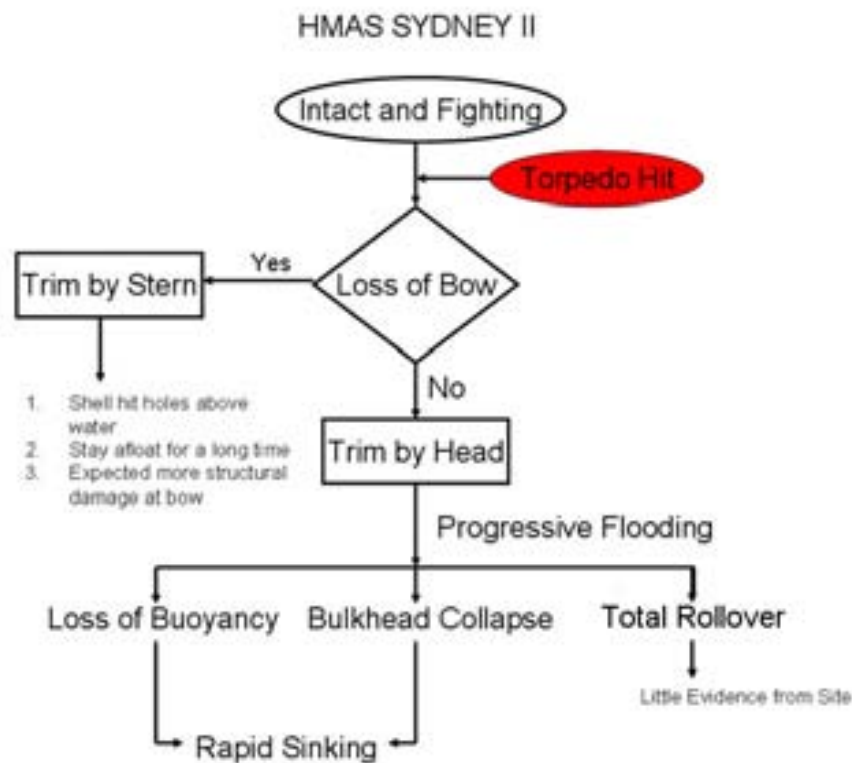

Figure 276 – Flow chart showing the probable sinking of Sydney

As described in Chapter 6, *Sydney* was subjected to a significant amount of damage from *Kormoran*. The primary trigger that initiated the start of the loss of *Sydney* was the hit from the torpedo on her bow.

The consequence of this torpedo hit would have had one of two consequences, namely:

- a) the bow was detached; or
- b) the bow remained attached, with damage due to the torpedo.

There are a number of previous incidents where the bow has detached from a ship [44]. In these incidents the ship trimmed by the stern. That is to say the ship will lie deeper in the water towards the aft end of the ship and the section towards the bow will lift out of the water. The principle reason for this is that the bow section includes a significant amount of weight, i.e. collision bulkheads, anchors and chains etc, however because of the fine hull form there is very little buoyancy holding this structure up. Therefore once these items are lost the moment trimming the ship by the bow is reduced. In these situations the remaining part of the ship will stay afloat for several hours or days and is often recovered to be repaired.

The final foundering of *Sydney* may have occurred as a result of a number of mechanisms, namely:

- a) She capsized and totally rolled over;

DSTO-GD-0559

- b) She rolled over and additional flooding occurred through openings in the Forecastle and upper deck leading to sinking; or
- c) She suffered a loss of buoyancy and plunged bow first.

If *Sydney* totally rolled over, once upside-down many heavy items would fall off the ship. The most significant of these would be the guns. The wreck of *Sydney*, as indicated in Chapter 6, clearly has all the guns in place. Added to this there are a significant amount of deck fittings that are also in place. Therefore it is suggested that if *Sydney* capsized she did not totally roll over.

Another form of capsize is where the ship rolls over to an excessive amount and does not have sufficient righting moments to return upright again. During this excessive roll many additional holes in the upper and Forecastle decks may become submerged. Additional flooding also occurs down through other flooding points (hatches, stairwells etc) as they also go underwater. This flooding process occurs very quickly and the ship ultimately sinks.

Other possible causes for the loss of buoyancy is when progressive flooding slowly works its way along to the stern of the ship until the bow section is so far underwater that *Sydney* essentially nose dived into the seaway. This may have been brought about by the increase in the sea state. Another scenario is that one of the internal bulkheads rapidly collapsed causing a sudden flooding. Once again in this scenario the ship would trim further by the bow and she would nose dive into the seaway. Whether an event of this nature occurred or not does not change the way the ship foundered. The only difference is that in the first case the event was slow flooding until it became critical from the buoyancy perspective and the second case relies on a critical load on a bulkhead collapsing to cause the flooding for sinking. Either way the final moment is relatively quick and the ship would be sinking bow down fairly fast.

In any of the scenarios leading to the loss of *Sydney* it is demonstrated above that this event could have occurred in anything ranging from 2 hours after the battle up to at least 12 hours after the battle. The actual time depends on the rate at which the sea state was deteriorating, thereby increasing the flooding rate, the amount of damage control that was being attempted and whether or not a structural overload occurred and increased the flooding rate.

#### 7.7.4 Sinking to the seabed

As stated above, it is not known exactly what happened in the last few minutes before *Sydney* sank. Some parts of the ship would still have been full of air when she left the surface. These could have included the relatively-undamaged after part of the ship, approximately from Y turret to the stern, partly filled or empty tanks, watertight compartments like those in the double-bottom spaces around the engine and boiler rooms and other intact internal spaces. Whilst all spaces would have rapidly started to flood through ventilation trunks and air escapes, the ship would have been sinking so fast that the external water pressure would have caused the intact compartments to implode. As shown in Chapter 6, there is extensive evidence of this implosion on the wreck e.g. the upper deck aft has been compressed down almost to the lower deck (Figure 277). The hull can be seen to be crushed in the vicinity of a number of tanks aft. Most of this damage would have occurred within about 30 m of the surface.

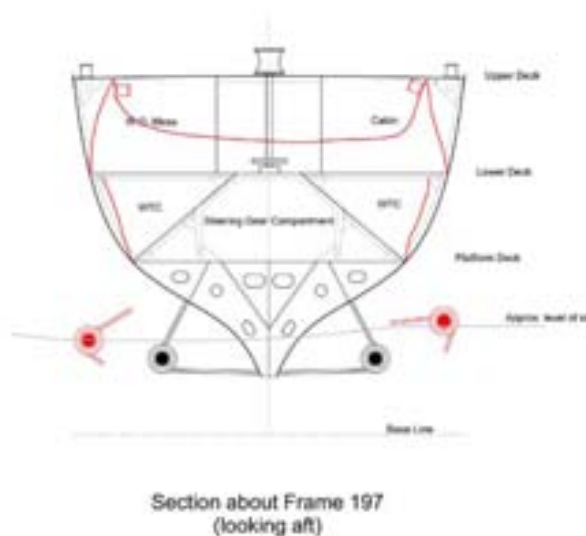

Figure 277 - A section through Sydney as she lies on the sea floor showing the implosion of her structure

The sinking of a ship is a violent process. The force of water passing the sinking *Sydney* would have torn off the masts and rigging and dislodged loose items on the deck. Heavier items would have soon followed, like the funnels, the top of the bridge and the director control tower. The boats, possibly still secured to their cradles, could have been torn off and were possibly further damaged by striking the ship or other wreckage. Very close to the surface, the force of water entering the damaged bow would have twisted and torn the bow off the ship and, in the process, aided by the water rushing past the hull, parts of the side shell, decks and bulkheads were twisted and broken off the ship. The shape of all these bits of wreckage would have caused them to sink at a different rate than the main hull, and they might have hit the ship, causing further damage, such as removal of small guns, deck fittings and small deck erections like the after conning position. In addition wreckage could have hit the front of the bridge causing some of the damage evident on the wreck. The rushing water would have lifted the torpedo tubes off the deck adding them to the mass of wreckage scattered throughout the debris field.

Most of this destruction would have probably occurred within the first two hundred metres. By then most of the ship was probably full of water. As *Sydney* continued to plunge towards the bottom, *Sydney* would have tended to level off and probably adopted a trim by the stern as the shape of the forward part of the ship offered more resistance to the passing water. Throughout the sinking, the main hull probably maintained some forward motion. This is evident from the position of the hull in relation to those parts of the ship which must have swept away first (Figure 278). Nevertheless, at the depth of 2.5 km, the debris field is quite compact [170].

DSTO-GD-0559

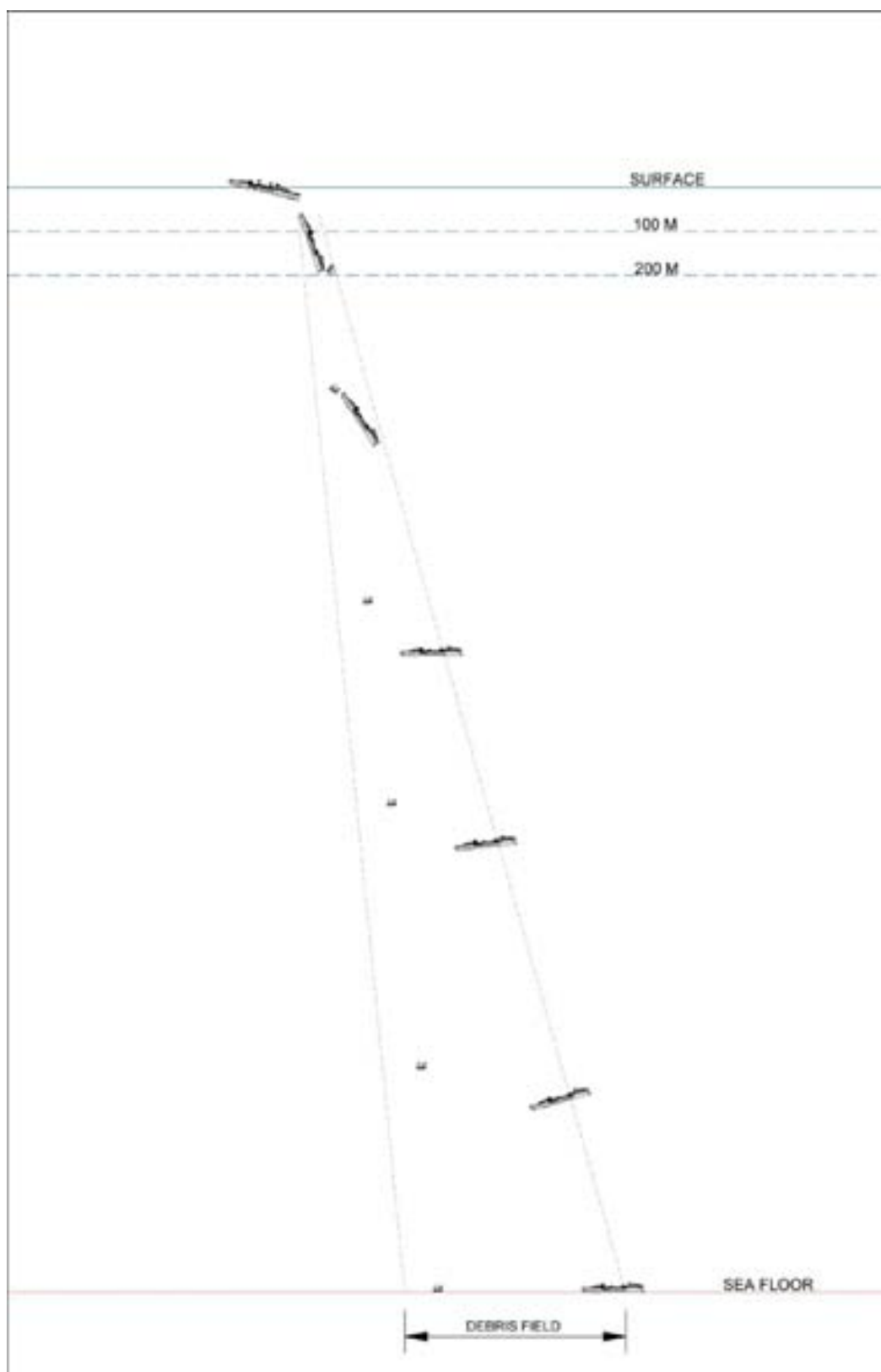

Figure 278 Schematic of the sinking process of Sydney



*Sydney* probably hit the sea floor stern first, causing further damage to the imploded stern. *Sydney* seems to have been moving forward slightly, as her shafts have been partly withdrawn from the hull during the impact. The impact with the sea floor would have caused weakened structure to collapse, like parts of the fire-damage forward superstructure and the 4" gun deck. Over the past 67 years, further collapse has probably occurred, particularly as fire-damaged structure corroded more rapidly than that which is better protected.

## 7.8 The Search for *Sydney*

The search for *Sydney* commenced on 24 November 1941 and was terminated on the 29 November after Australian and Dutch aircrews flew 118 sorties, 825 flying hours and were supported by 6 naval ships and 15 merchant ships [321]. Figure 279 shows a composite diagram of all the sorties flown in the search from 25 November until 29 November [74, 322].

The search on 24 November was a fan search from Rottnest Island on a bearing of 270 and 340°. The aircraft were instructed to search for *Sydney* or an object 555' long. Unfortunately, no record can be found of the height that the flight was carried out at but the flight would have been at such a height to offer maximum visibility for detecting an object 555' long. At this height, there would have been little possibility of finding boats or floats let alone men in the water.

Over the next 5 days many sorties were flown with the instruction to search for *Sydney* as well as ship's boats and rafts [321-323]. The sorties were flown at an appropriate height to spot ship's boats and it is believe that this was at approximately 1500' [322]. The parallel track sorties were also flown at a visibility of 10 miles and if the visibility decreased below this, then the search pattern was to be reduced to ensure complete coverage [324, 325].

The air search was successful in sighting most of the lifeboats from *Kormoran* but was not successful in finding any other objects. All of the small objects such as the life belts, the RAN type Carley float and the two foreign type Carley floats were found by the naval or merchant ships - not by any of the aircraft. It is also instructive that the Carley float discovered by *Heros* on 28 November was not sighted by any of the aircraft despite the fact that multiple searches were carried out over that and areas to the south during the period 26-28 November [74, 326]. Similarly, two of *Kormoran* lifeboats reached the Western Australian coast without being detected from the air [326].

Figure 280 shows the location of the debris found by the ships and the wreck site of *Kormoran* and *Sydney* and Figure 281 shows the approximate number of times each of the 30 mile X 30 mile square was entered by a search aircraft [326]. It does show that the air search was extensive and covered what is now known to be the wreck site. Figure 280 and Figure 281 also show that any drifting objects, life boats or floats should have been spotted a number of times by the search aircraft given that they were floating from the wreck site position at a latitude of 26 ° 14 ' 37 " S and a longitude of 111 ° 13 ' 3 " E [133].

DSTO-GD-0559

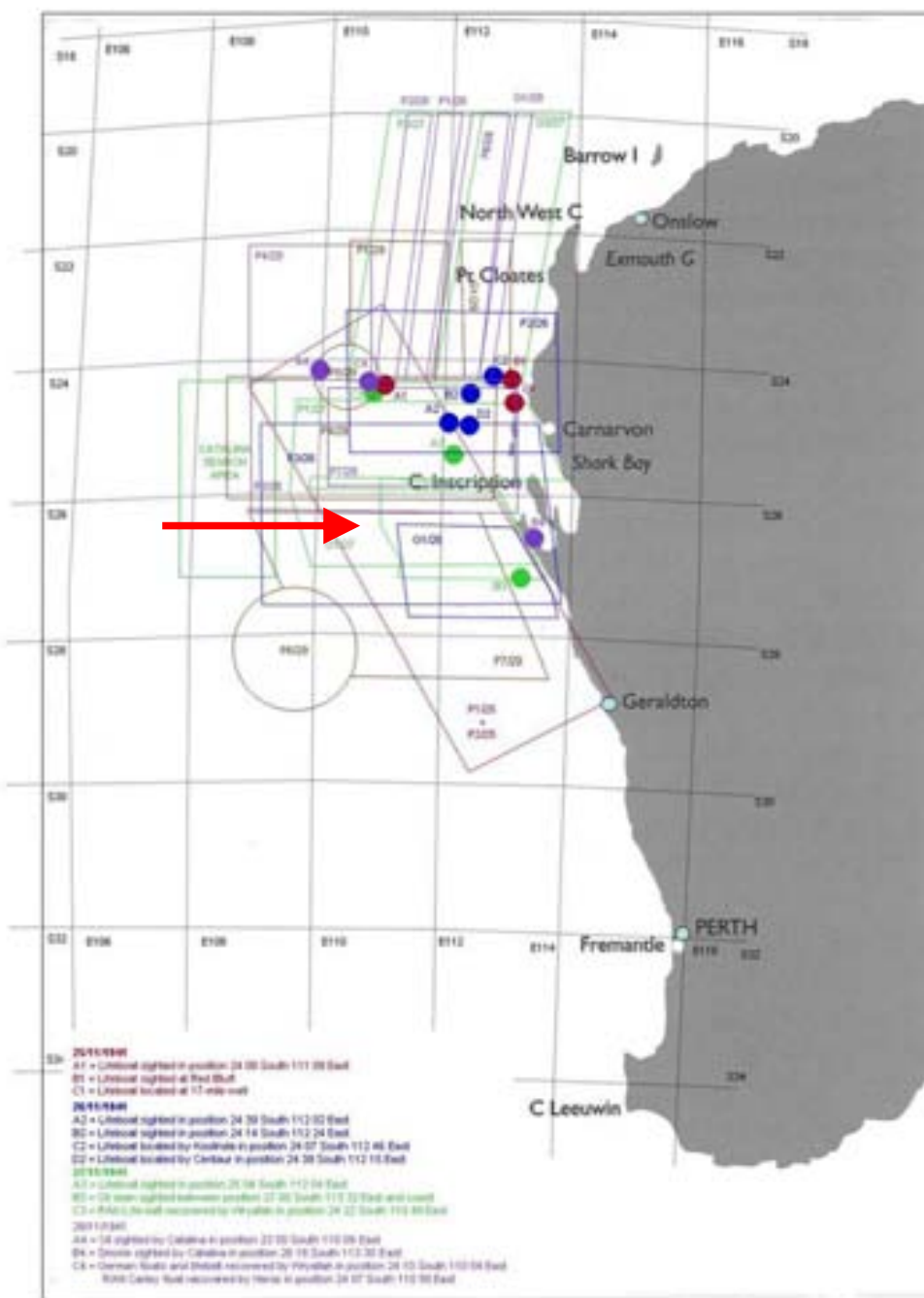

Figure 279: Composite diagram of the search sorties flown by aircraft over the period 25 -29 November 1941 [74, 322]. The red arrow marks the approximate wreck site

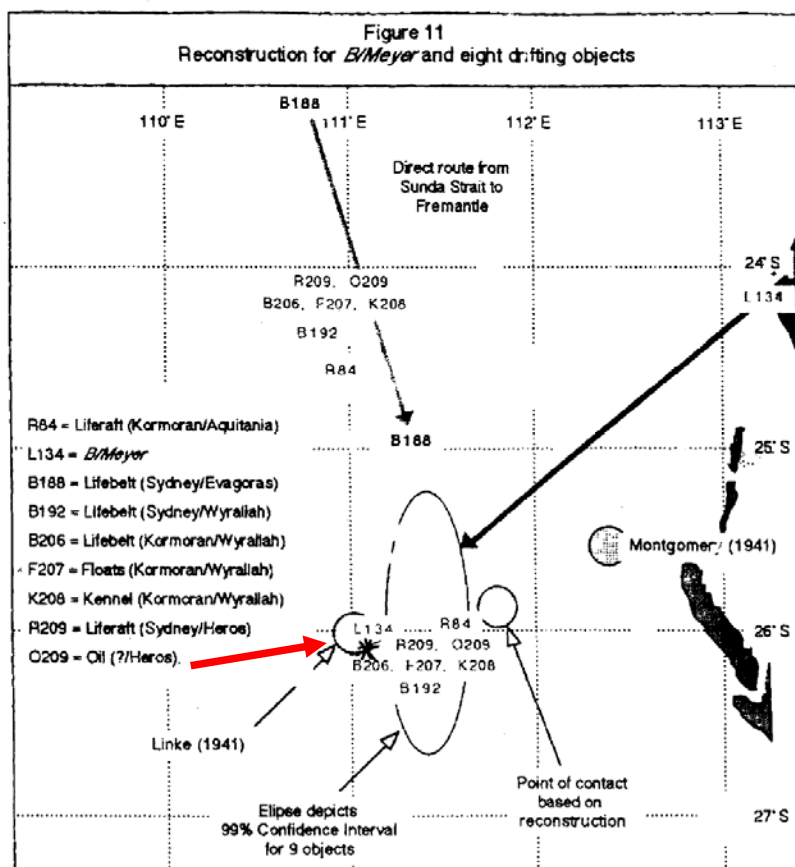

Figure 280: Location of debris found by HMAS Wyrallah, HMAS Heros and Evagoras [326]

DSTO-GD-0559

**Figure 13**  
Number of searches per 30'x30' square  
(regardless of ET)

|      | 108°E | 109°E | 110°E | 111°E | 112°E | 113°E |   |   |   |   |
|------|-------|-------|-------|-------|-------|-------|---|---|---|---|
| 23°S |       | 1     | 1     | 1     | 2     | 2     | 3 | 5 | 3 | 4 |
|      |       | 1     | 1     | 1     | 3     | 4     | 5 | 6 | 7 | 6 |
| 24°S |       | 1     | 2     | 2     | 4     | 5     | 4 | 6 | 7 | 6 |
|      | 1     | 1     | 1     | 4     | 3     | 4     | 6 | 7 | 7 | 6 |
| 25°S | 1     | 1     | 1     | 4     | 4     | 5     | 6 | 6 | 6 | 5 |
|      | 1     | 1     | 1     | 4     | 4     | 6     | 6 | 6 | 6 | 5 |
| 26°S | 1     | 1     | 1     | 3     | 2     | 5     | 4 | 5 | 5 | 4 |
|      | 1     | 1     | 1     | 3     | 2     | 4     | 4 | 5 | 6 | 5 |
| 27°S | 1     | 1     | 1     | 3     | 2     | 4     | 4 | 5 | 6 | 5 |
|      |       | 1     | 1     | 1     | 3     | 4     | 4 | 3 | 3 | 2 |

Figure 281: Number of times an aircraft entered a 30 mile by 30 mile search square [326]

Figure 279 and Figure 281 show that the search was probably concentrated too far to the North/North East of the actual wreck site. The decision to redirect aircraft to search north up to 20°S was based on the possibility that *Sydney* was limping to Singapore or Surabaya.

Given this, the question that arises is that if there were survivors in the water, could the air search have successfully found them? At the height that the sorties were flown, the assumed visibility, with a sea state of 3-4, a swell of 3-4 metres [327] and wind of 4-6 (Beaufort scale) [328], it is highly unlikely that any individuals in the water would have been sighted by the aircraft. The US Coast Guard has carried out significant studies into detection of individuals in water for Search and Rescue (SAR) applications. They have shown from extensive SAR experimentation that an individual in water has an almost zero probability of detection once the lateral range (the distance from the search aircraft to the object in the water) goes beyond 0.6 nm. This data was for a P-3 maritime patrol aircraft flying at 627 ft. altitude [329].

Kirsner has done a study and proposed that from the area covered by the search aircraft and based on the assumption of the battle being at 111°E 26°S, the probability of detection of life rafts would be 25% (for one aerial pass) to approximately 77% (for 5 aerial passes) [326]. Even given the limitations of the search process noted above, the aircraft spotted all the lifeboats in the sea but no life rafts. It is highly likely this was because there were none to find.

The USS *Indianapolis* was torpedoed by a Japanese submarine. Approximately 800 crew made it into the water, many wearing only their personal kapok life jackets or their life

belts. They were only sighted when four days later, a single aircraft spotted an oil slick and descended to 900' to check. Upon descending the pilot spotted what he thought were heads in the water and further descended to 300' to identify the men in the water. The survivors told of firing flares and shining mirrors at other aircraft that passed overhead but they were not spotted [74].

A number of questions have been raised regarding the thoroughness of the search with aircraft not completing their search due to mechanical problems, navigation errors, and the incompleteness of the search coverage [324].

It is also worth noting that 60 of the crew from *Kormoran* evacuated into a dingy, which subsequently burst and all the occupants fell into the ocean [117]. They were also not found during the search process.

## 7.9 Likelihood of survivors

### 7.9.1 Survival in the water

It is not possible to factually state that there were any survivors from *Sydney* that entered the water. However, it is possible that some crew from *Sydney* entered the water at some stage during or after the engagement. Those during the engagement were likely to have been blown off the deck as a result of blast or fallen overboard. Those after the engagement were possibly swept off the decks when *Sydney* went down or entered the water if an abandon ship order was given. Unfortunately, as stated above, there is no evidence to support any of these statements and they must be seen as supposition. It should be noted that any survivors that did make it into the water would most likely have been affected by injuries, shock, burns and possibly the effects of smoke and/or inhalation of toxic fumes.

There is little doubt that the ship's boats were either damaged or were not able to be lifted off *Sydney* due to the aircraft crane being damaged. The Carley floats would have been either blown off during the engagement or damaged with shell hits, fire or fragments. They would have been of little use. If any Carley floats did survive and floated, then it is possible that some survivors may have reached a float. Any other survivors would not have had anything other than their life belts to help them survive.

The survival time of someone wearing a life belt was hours [74]. Even if a person entered the water, the life belt did not provide adequate head support. Hence if the wearer fell unconscious, or fell asleep, there was a danger that the wearer would flip over and drown [74]. Although the Carley float provided a degree of survival capability, Royal Navy data suggests that a person in a Carley float would only survive for 3 to 5 days [330].

DSTO-GD-0559

Contemporary data and modelling on survival of people at sea show that at a water temperature of greater than 20°C, hypothermia is not a critical factor. However, the data shown in Figure 282 and Figure 283 suggests that a person can survive for greater than 12 hours at 25°C and possibly up to 40-50 hours [331, 332]. It should be noted that none of this data can be validated.

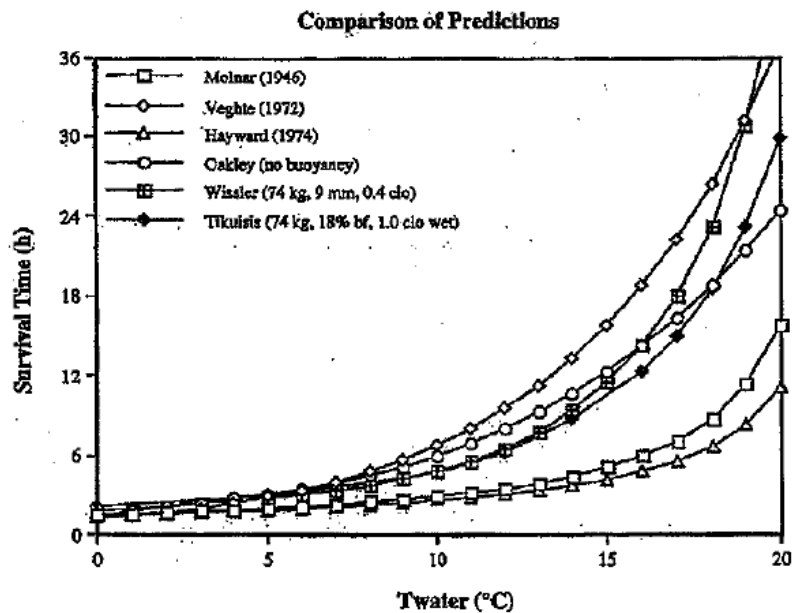

Figure 282: Summary of hypothermia models for survival at sea [332]

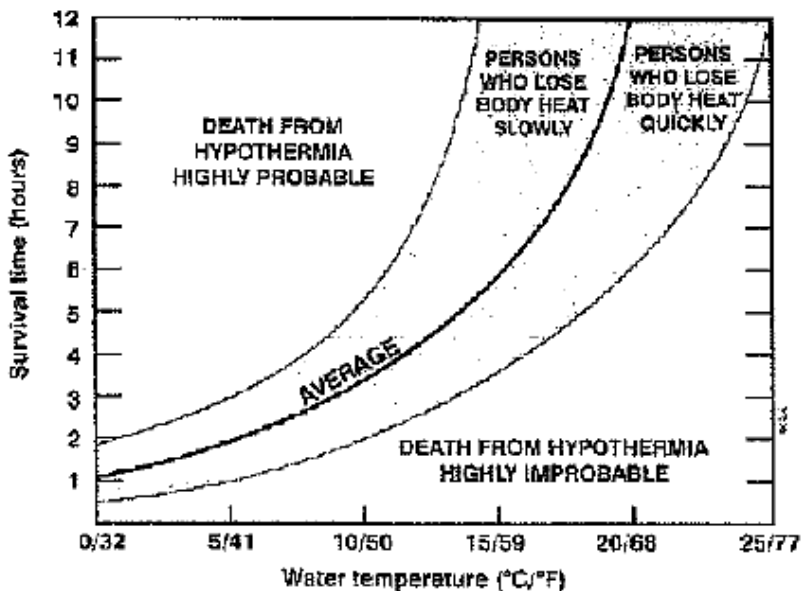

Figure 283: Survival curves from the IAMSAR manual[333]

Given that neither *Sydney* nor *Kormoran* were accompanied by any other ships nor were there any other ships in the immediate vicinity which were aware of the encounter, there was little possibility of survivors being picked up quickly.

Once in the water the major problem was drowning, dehydration and the presence of sea creatures particularly sharks. The water temperature in this area was approximately 23-24°C [334], so hypothermia was not a significant factor in survival. If the survivors were supported by only a life belt, then the constant breaking of waves over the head could result in the ingestion of salt water leading to drowning. During the battle and the sinking of *Sydney* the sea states had a maximum wave height of between 1.25 m and 2.5 m. Surprisingly, drowning can result from the ingestion of as little as 150 ml of salt water [114]. Given the limited support and buoyancy of the life belts, after “hours” in the water any survivors would most likely to have drowned and their bodies would have sunk.

As the body sinks into deep water, the pressure of the water tends to compress gases in the abdominal and chest cavities with the result that the body displaces less water as it sinks deeper and consequently becomes less buoyant [335]. Once the body sinks, it also commences to decompose due to the action and growth of anaerobic gas forming organisms in the intestines. The growth of these organisms causes the abdomen followed by the whole body to bloat and to swell with gases. This is often called putrefaction [117, 331, 336]. The critical factor in this process is the water temperature. The lower the water temperature the slower is the rate of putrefaction. Once the body swells, it then rises to the surface where it floats. Typically, the time for a body to rise is between 3 and 10 days but can take much longer in cold waters and never at all if the water is very cold and/or if the body is lying at a great depth [117, 331, 336]. In this case the survivors from the encounter would have sunk to a depth of approximately 2500 m. Given the significant water pressure on the body at this depth, it is likely that the putrefaction process would not result in enough gas generation to make the body buoyant. If however any bodies did rise to the surface, given the water temperature at 2500 m of approximately 2.5°C [337], the bodies would have taken longer than the typical 3-10 days to rise. Based on these scenarios, the search would not have found any bodies due to them either not rising to the surface or the bodies were not found as the search for survivors was called off prior to them surfacing.

Without adequate supplies of fresh water, any survivors would have had to face the issue of dehydration. Often this resulted in survivors drinking seawater, which ultimately leads to unconsciousness and drowning.

The presence of sharks and other marine creatures was a significant problem for survivors in the water. A survivor from *Kormoran*, Mr. A. Marmann stated that in his boat they had a school of sharks following them until they reached shallow waters [323]. The presence of a large number of sharks was noticed by HMAS *Heros*, which was one of the boats participating in the search for survivors.

The US Coast Guard has determined that shark attack becomes a significant risk factor for survival at sea when the water temperature is above 20°C [338].

There are examples of survivors from ships sunk during WW II who reported that sharks were significant problem. Perhaps the most significant was the sinking of the USS *Indianapolis* in July 1945 [74]. Approximately 800 crew evacuated into the water as there

DSTO-GD-0559

was insufficient time to launch the ship's boats. Ultimately only 320 survivors were rescued after three and a half days, the rest being taken by the sharks or drowning due to injuries or drinking sea water.

### 7.9.2 Why No Survivors?

As noted in Chapter 8 of this report, during the engagement with *Kormoran*, *Sydney* received over 40 15 cm shell hits on the port side, slightly more on the starboard side, a single torpedo in the bow and hundreds of small calibre hits to all areas of the ship.

The 2 cm gunners on *Kormoran* were instructed to train their weapons on the 4" guns of *Sydney* to prevent them from being brought into action [74]. The shielding on the gun decks was limited and the crews would have been incapacitated almost instantly. Many of the 6" gun crews were likely to have been incapacitated by shell fire, from fragments or from the effects of the torpedo (the forward crew). The torpedo crew would have been incapacitated by small calibre fire or blast and fragments from the larger shells. The forward bow section of the ship was extensively damaged by the torpedo hit and most crew in this part of the ship would have been incapacitated. The many large calibre shells that penetrated the hull and superstructure of *Sydney* would have caused great damage, significant loss of life or severe injuries and started many fires above and below decks. Many of the senior officers would have been incapacitated early on in the encounter as a result of the shell hits to the bridge. Most of the damage control parties on the lower deck would also have been incapacitated. The number of crew that were either incapacitated or were trapped in spaces with no means of escape would have been significant. Figures presented herein propose that at least 70% of the crew were incapacitated or trapped in spaces due to fires and escape passages being blocked. Given the torpedo hit to the forward part of the ship, the extensive weapons and fire damage to the midships region and some of the after part of the ship, it is highly likely that the only survivors were in the stern of the ship and possibly the aft engine room. The remaining crew would have been trying to save the ship by bringing it under control and possibly trying to carry out limited damage control.

If any crew were able to evacuate or managed to get off the ship earlier in the engagement, they would have been suffering from shock and injuries. Royal Navy data shows that during WW II, two thirds of all people who successfully abandoned ship eventually died in the water, or in a Carley float [111]. If there were any crew from *Sydney* who did escape into the water, they were not likely to have been able to use any of the Carley floats or the ship's boats. Their only means of survival was their inflatable life belt. If they were blown off, or fell overboard, during the battle, the many shells that were hitting the hull of *Sydney* would have produced large numbers of fragments that would have been lethal to anyone floating in the water. Similarly, any shell that fell short and detonated in the water would also have been devastating to anyone floating on the water.

After the engagement, *Sydney* was subjected to deteriorating sea conditions which resulted in an increased roll of the ship and subsequently increased the flooding. This increased the roll motion would almost certainly have made any damage control operations or evacuation virtually impossible. It is highly probable that the increased roll eventually led to deck edge immersion and additional flooding and finally caused a roll angle beyond which *Sydney* could not recover. *Sydney* then lost any remaining



DSTO-GD-0559

buoyancy and eventually sank. Any remaining crew would have been trapped below decks in the aft part of the ship, with no possibility of escape.

Given the delay in starting the search process and the fact that the search was limited in its ability to find individuals in the water, it is highly likely that any survivors were not detected and subsequently perished. Given the depth of the ocean and the limited possibility that a drowned body would later float to the surface, the likelihood of finding any trace of bodies after the first few days would be very small.

## 8. Concluding Remarks

The battle between *Sydney* and *Kormoran* was a unique sea battle in that *Sydney* was not only hit by a torpedo, but was also pounded by accurate and sustained gun fire from close range for an extended period of time. Other WWII ships had survived torpedo hits and others had survived shell hits from larger calibre shells. However, *Sydney* had to endure the sustained attack at close range from 15 cm shells smashing into the sides of the ship, raking the upper decks with 20 mm shells at a rate of fire of more than 100 rpm and sustained shelling with 3.7 cm guns. As *Sydney* sustained hit after hit, the damage to both equipment and crew multiplied along with the loss of numerous capabilities. Fires broke out in many areas of the ship and choking smoke and toxic gases engulfed the upper decks and was drawn into the lower decks. The torpedo hit to the bow resulted in extensive forward flooding and *Sydney* trimmed by the bow. The loss of the ship's electrical power and the physical blockage to passageways for egress would have made any damage control operations difficult to conduct. Fire mains and Main Suction lines would have been significantly damaged and the ability to pump water to fight the fires would have been limited if at all due to the lack of electrical power. This is particularly true for all areas forward of the machinery spaces. Although the initial action resulted in damage to the port side of *Sydney*, the turn to port after 5 minutes exposed *Sydney* to shelling on its starboard side and magnified the damage with as many shell hits on the starboard side as the port side. The boats and Carley floats on port and starboard sides were either blown overboard or were damaged directly by shells or the thousands of fragments that were spraying around the upper decks. The boats and floats were rendered useless for evacuation or lifesaving.

After the engagement ceased, *Sydney* limped away to the south east travelling at approximately 5 knots. At this time *Sydney* was severely damaged with a very large number of casualties, several major fires, many small fires, much of the upper and lower decks filled with smoke, flooding occurring in the bow area and electrical power gone for much of the ship. The weapon holes were fuelling the fires by allowing air to ingress from outside. The damage control crews would have been overwhelmed at this stage and any damage control that was being conducted was simply to try to save the ship. It is most likely that any remaining crew were below decks in the stern of *Sydney* or the aft engine room. As the sea conditions deteriorated to sea state 4 *Sydney* began to roll and more water flooded in through the weapons holes in the hull and deck openings. It is probable that the roll became significant and increased with flooding and increased sea state, rolling from 15° up to 40°. At these roll angles, immersion of the edge of *Sydney's* deck was likely and any attempt at damage control operations or movement around the ship would have been virtually impossible. Any survivors would simply have been trying to stop being thrown around and would have been trapped below decks. Eventually *Sydney* is likely to have rolled to an angle beyond which she could not have recovered, lost buoyancy and sank rapidly. It is possible that this process was also accompanied by the sudden collapse of one or more watertight bulkheads which further contributed to the sudden and catastrophic loss of buoyancy and sinking. As *Sydney* sank the weakened bow was violently torn off and plunged towards the sea floor.

It is highly unlikely that there were any of the crew of *Sydney* who were able to evacuate the ship or managed to get off earlier in the engagement.

## 9. Acknowledgements

Many individuals were involved in the analysis and the preparation of this report other than the main authors. In particular, the following people are acknowledged for their contributions to this report– Ms. J. Cocking (DSTO Chief Maritime Platforms Division) Ms. H. Pottage (DSTO Research Library), Mr. T. Travers (DSTO – Maritime Platforms Division), Dr. J. Wharrington (DSTO – Maritime Platforms Division), Mr. D. Bell (National Archives Australia - Canberra), Mr. M. Brennan (National Archives Australia - Melbourne), Mr. R. Sanderson (Australian War Memorial - Canberra), Mr. J. Perryman (RAN Sea Power Centre), Ms. J. O'Reilly (Defence Science Communications), Mr. T. Heeren (Defence Science Communications) and Mr. J. Nicholls (Boeing Australia Limited).

## 10. References

1. *HMAS Sydney - Profile (As Fitted)* (1935) MP551/1,136AF/1[1], [Drawing] Canberra, ACT, National Archives Australia
2. *HMAS Sydney - Forecastle Deck (As Fitted)* (1935) MP551/1,136AF/4, [Drawing] Canberra, ACT, National Archives Australia
3. *HMAS Sydney - Lower Deck (As Fitted)* (1935) MP551/1,136AF/6, [Drawing] Canberra, ACT, National Archives Australia
4. *HMAS Sydney - Platform Deck (As Fitted)* (1935) MP551/1,136AF/7, [Drawing] Canberra, ACT, National Archives Australia
5. *HMAS Sydney - Armour and Protective Plating (As Fitted)* (1935) MP551/1,136AF/54, [Drawing] Canberra, ACT, National Archives Australia
6. *HMAS Sydney - Superstructure and Bridge (As Fitted)* (1935) MP551/1,136AF/3, [Drawing] Canberra, ACT, National Archives Australia
7. *HMAS Sydney - Hold (As Fitted)* (1935) MP551/1,136AF/8, [Drawing] Canberra, ACT, National Archives Australia
8. "H.M.S. 'Amphion', 'Apollo' & 'Phaeton' - Longitudinal Bulkhead 25-S6 P & S", National Archives Australia
9. "Amphion, Apollo & Phaeton - Forward Superstructure Deck & Side Plating", National Archives Australia
10. *HMAS Sydney - Expansion of Inner Bottom Plating (As Fitted)* (1935) MP551/1,136AF/48, [Drawing] Canberra, ACT, National Archives Australia
11. *FREDYN Version 9.9*, (2008) [Computer software] Maritime Research Institute Netherlands
12. *Paramarine Version 6.0*, (2008) [Computer software] Gosport, Hampshire, GRC Ltd
13. *HMSs 'Amphion', 'Phaeton' & 'Apollo' - Hydrostatic Curves*, (1933) NAA.064.0002, Canberra, ACT, National Archives Australia
14. *Modified Leander - Metacentric Diagram* (1932) COI.003.0108, Sydney, NSW, HMAS Sydney II Commission of Inquiry
15. *HMAS Sydney II ships cover* (1935),
16. van't Veer, A. P. (2008) *PRECAL V6.4 Theory manual*, MARIN Report No. 17926-2-CPS, Maritime Research Institute Netherlands
17. *HMS 'Amphion' Also 'Phaeton' & 'Apollo' - Body Plan As Laid Off - Scale 1/2 Inch to One Foot*, National Archives Australia
18. NcNeel North America. *Rhinoceros : NURBS modeling for Windows : Modeling tools for designers*. Updated 2007 [Accessed 8 December 2008]; Available from: <http://www.rhino3d.com/>.
19. *Modified Leander hogging condition*, (1935) COI.53, [Drawing] Sydney, NSW, HMAS Sydney II Commission of Inquiry
20. *HMAS Sydney - Hydrostatic Curves*, (1935) NAA.064.0002, Canberra, ACT, National Archives Australia
21. Lewis, E. V., (ed.) (1988) *Principles of naval architecture : Volume 1 - stability and strength*. 2nd rev. ed., Jersey City, NJ, Society of Naval Architects and Marine Engineers.
22. Adamchak, J. C. (1997) *ULTSTR (1997) : the revised program for estimating the collapse of ship hulls or hull components under longitudinal bending or axial compression*, Report No. NSWCCD-TR-65-97/21, West Bethesda, MD, Naval Surface Warfare Center, Caderock Division

23. HMAS Sydney - Sections (As Fitted) - Scale 1/8 Inch = 1 Foot - Plan Reference, NAA.029.0001, Canberra, ACT, National Archives Australia
24. HMS 'Apollo' & 'Phaeton' - Expansion of OB Plating - Confidential - Devonport - MCD 31675 - 24/8/1933, National Archives Australia
25. Lang, D. W. and Warren, W. G. (1952) Structural strength investigations on destroyer ALBUERA. *Quarterly Transactions of the Institution of Naval Architects* 94 (4) October 1952
26. Blender Foundation (2008) *Blender Version 2.48A* [Computer software] Amsterdam, Amsterdam Blender Institute
27. FSF.003.0035 (2008) [Photograph] Perth, WA, Finding Sydney Foundation
28. Asmussen, J. *Admiral Graf Spee - Operational history*. Updated 4 June 2006 [Accessed 10 December 2008]; Available from: [http://www.deutschland-class.dk/admiral\\_graf\\_spee/admiral\\_graf\\_spee\\_operation\\_hist.html](http://www.deutschland-class.dk/admiral_graf_spee/admiral_graf_spee_operation_hist.html).
29. Department of the Navy -- Naval Historical Center (US). *Battle of the River Plate, December 1939*. Updated 8 October 2006 [Accessed 10 December 2008]; Available from: <http://www.history.navy.mil/photos/events/wwii-atl/batlt-41/r-plate.htm>.
30. *Panzerschiff Admiral Graf Spee*. [Accessed 10 December 2008]; Available from: [http://www.marine-ab-1900.de/Schiffe/graf\\_spee.html](http://www.marine-ab-1900.de/Schiffe/graf_spee.html)
31. Royal Navy. *The loss of Sheffield : Falklands conflict : battles : history : Royal Navy*. (2008) [Accessed 10 December 2008]; Available from: <http://www.royalnavy.mod.uk/server/show/nav.5877>.
32. Wikipedia. *HMS Sheffield* [Accessed 8 December 2008]; Available from: [http://upload.wikimedia.org/wikipedia/en/9/90/HMS\\_Sheffield\\_\(D80\).jpg](http://upload.wikimedia.org/wikipedia/en/9/90/HMS_Sheffield_(D80).jpg).
33. The News Centre (UK). *Terrible fate for HMS Sheffield*. [Accessed 8 December 2008]; Available from: <http://www.thenewscentre.co.uk/falklands/shiny.htm>.
34. Royal Navy. *News and events : Royal Navy - RFA Sir Galahad says farewell to Falklands Veterans*. (2008) [Accessed 8 December 2008]; Available from: <http://www.royalnavy.mod.uk/server/show/ConWebDoc.5645/changeNav/3533>.
35. Royal Navy. [Accessed 8 December 2008]; Available from: <http://www.royalnavy.mod.uk/img/navy/ConMediaFile/rnimage.php?mainimage=sir-galahad.jpg&width=1024>.
36. Kennett, S. R., Gamble, G. I. and Li, J.-d. (1998) *Modelling of the HMAS Westralia fire*, DSTO-TR-0698, Melbourne, Vic., Defence Science and Technology Organisation (DSTO)
37. Emergency & Disaster Management Inc. *Ship fire*. (2005) [Accessed 8 December 2008]; Available from: [http://www.emergency-management.net/ship\\_fire.htm](http://www.emergency-management.net/ship_fire.htm).
38. Wikipedia. *2004 SuperFerry 14 bombing*. [Accessed 8 December 2008]; Available from: [http://en.wikipedia.org/wiki/2004\\_SuperFerry\\_14\\_bombing](http://en.wikipedia.org/wiki/2004_SuperFerry_14_bombing).
39. *Loss of HMS Sheffield - Board of Inquiry* (1982), London, Royal Navy
40. US Department of Defense *Formal investigation into the circumstances surrounding the attack on the USS Stark (FFG 31) on 17 May 1987 : Volume 1 : Report of investigation*,
41. Gamble, G. I. and Kennett, S. R. (1998) *Ship Survivability and Enhancement Program (SSEP) : data*, DSTO-GD-0190, [CD-ROM] Melbourne, Vic., Defence Science and Technology Organisation (DSTO)
42. International Maritime Organisation (IMO) (2004) *The International Convention for the Safety of Life at Sea (SOLAS)*. Con. ed, London, IMO
43. *Damage control have saved H.M.S. Arethusa "...was able to reach harbour safely"* (1942) RAN.002.0002, [Poster]

DSTO-GD-0559

44. *HMS Arethusa : torpedo damage* (1943) ADM 267-6 HMS Arethusa, [Report] London, Great Britain. Admiralty
45. *HMS Liverpool : torpedo damage* (1940) ADM 267-70 HMS Liverpool, [Report] London, Great Britain. Admiralty
46. *Damage control could have saved H.M.S. Southhampton "...lost through lack of Firemain pressure"* (1941) RAN.002.0010, [Poster]
47. *HMAS Australia (action damage report)*, (1943) 2026/3/583, [Various Papers] Canberra, ACT, National Archives Australia
48. Great Britain. Admiralty. Director of Naval Construction (DNC) (1943) *HMS Birmingham : torpedo damage - 28th November 1943*, DNC 48 / R286, [Report] Bath, DNC Department
49. *HMAS Hobart, repairs to war damage*, (1943) 2026/3/511, [Various Papers] Canberra, ACT, National Archives Australia
50. Royal Navy. *Key events : Falklands conflict : battles : history : Royal Navy*. (2008) [Accessed 4 December 2008]; Available from: <http://www.royalnavy.mod.uk/server/show/nav.5872>.
51. British Broadcasting Corporation. *BBC - History - Falklands conflict gallery*. [Accessed 8 December 2008]; Available from: [http://www.bbc.co.uk/history/recent/falklands/falklands\\_gallery\\_05.shtml](http://www.bbc.co.uk/history/recent/falklands/falklands_gallery_05.shtml).
52. Royal Navy. *HMS Sheffield on fire*. (2006) [Accessed 8 December 2008]; Available from: <http://www.royalnavy.mod.uk/server?show=ConMediaFile.25062&outputFormat=print#>.
53. *HMS Sheffield after Exocet missile hits*. [Accessed 8 December 2008]; Available from: <http://www.geocities.com/CollegePark/Quad/5504/slide27.html>.
54. Bright, D. A., Williams, R. M. and McLaren, A. S. (2005) Comparative photometric analysis of structural degradation on the bow of RMS Titanic. In *OCEANS 2005 MTS/IEEE Conference and Exhibition* Washington DC:17-23 September 2005 IEEE
55. Garzke, W. H., et al. (2000) A marine forensic analysis of the RMS Titanic. In *OCEANS 2000 MTS/IEEE Conference and Exhibition* Newport, RI:11-14 September 2000 IEEE
56. Jurens, W., et al. *A marine forensic analysis of HMS Hood and DKM Bismarck*. The Marine Forensic Panel (SNAME) [Accessed 16 December 2008]; Available from: [http://www.sname.org/committees/design/mfp/website/recent/research/hood\\_bismarck\\_1.pdf](http://www.sname.org/committees/design/mfp/website/recent/research/hood_bismarck_1.pdf).
57. US Department of Commerce. National Oceanic and Atmospheric Administration. *NOAA Ocean Explorer - Cultural Heritage Gallery*. Updated 19 July 2006 [Accessed 24 September 2008]; Available from: <http://oceanexplorer.noaa.gov/gallery/cultural/cultural.html>.
58. *HMAS Sydney - Upper Deck (As Fitted) - Scale 1/8 Inch = 1 Foot - Plan Reference: 136AF/5s*, National Archives Australia
59. Brown, D. K. (1983) *A century of naval construction*, London, Conway Maritime Press
60. *HMS Ajax*, [Photograph] Plymouth, Tom Molland Ltd
61. McBride, K., (1997) Eight six-inch guns in pairs - the Leander and Sydney class cruisers. In: *Warship 1997 - 1998*: pp. 176-177. London, Conway Maritime Press,
62. *HMAS Sydney ship's cover* (1935) UKAA.015.0001, National Maritime Museum (UK)
63. *HMAS Sydney, Fighting Efficiency - Protection of Fire Control System and Alternative controls*, (1938) MP1049/5,2026/3/294, [Letter] Canberra, ACT, National Archives Australia
64. *Armament of Orion class*, (1940) MP1049/5,2026/3/397, [Letter] Canberra, ACT, National Archives Australia

65. *Cable from Secretary Department of Navy to Admiralty*, (1943) MP1049/5,2026/3/533, [Letter] Canberra, ACT, National Archives Australia
66. *HMAS Sydney ship's book* (1935) NAA.090.0001-03, National Archives Australia
67. Raven, A. and Roberts, J. (1980) *British cruisers of World War Two*, London, Arms and Armour Press
68. *Legend of Particulars of Proposed New Cruiser - 'Modified Leander' - 1932 Programme*, National Archives Australia
69. Campbell, J. (2002) *Naval weapons of World War II*, London, Conway Maritime Press
70. "6 Inch Twin Mounting XXI General Arrangement of Mounting (As Drawn for a Turret) - H.M.S. 'Amphion', 'Apollo' & 'Phaeton'", (1935) MP551/1,N1060, [Drawing] Canberra, ACT, National Archives Australia
71. Rush, J. T. (2008) *List of assumptions about the disposition of the crew at action stations*, CORR.009.0020, [Letter] Sydney, NSW, HMAS Sydney II Commission of Inquiry
72. Oakley, G. W. (2008) HMAS Sydney modified Leander cruiser : an introduction to her armament and fire control systems. In *HMAS Sydney II Commission of Inquiry* Sydney, NSW Commonwealth of Australia (PTE.005.0142-0353) (PTE.005.0142)
73. Digiulian, T. *NavWeaps - Naval Weapons of the World : From 1880 to Today*. Updated Updated 31 August 2008 [Accessed December 2008]; Available from: [http://www.navweaps.com/Weapons/index\\_weapons.htm](http://www.navweaps.com/Weapons/index_weapons.htm).
74. Olson, W. (2000) *Bitter victory - the death of HMAS Sydney*, Nedlands, WA, University of West Australia Press
75. Dollard, A. (2008) Witness statement. In *HMAS Sydney II Commission of Inquiry* Sydney, NSW:1 September 2008 Commonwealth of Australia (TRANS.014.0068\_R)
76. Pfennigwerth, I. (2007) *The Australian Cruiser Perth 1939-1942*, Dural, NSW, Rosenberg
77. Fisher, T. P. (2008) Statutory Declaration of Thomas Patrick Fisher. In *HMAS Sydney II Commission of Inquiry* Perth, WA:23 June 2008 Commonwealth of Australia (SUBM.006.0323) (WIT.001.0001)
78. Radcliffe, R. V. (2008) Statutory Declaration of Richard Vincent Radcliffe. In *HMAS Sydney II Commission of Inquiry* Melbourne, Vic Commonwealth of Australia
79. Friends of HMCS Haida. *HMCS Haida : Tour Stop 2*. [Accessed December 2008]; Available from: <http://hmcshaida.ca/torptube.html>.
80. "Amphion", "Apollo" & "Phaeton" - *Fore Part Framing (Elevation)*, (1935) MP551/1,136/76, Canberra, ACT, National Archives Australia
81. *HMS Phaeton - Body Plan as Laid Off Showing Plate Edges - Traces of Longitudinaals Etc - Scale 1/2 Inch = 1 Foot - Tracing: No 76*, National Archives Australia
82. *HMAS Sydney - Typical Examples of Damage and Control - Plan Reference: 136/AF118*, National Archives Australia
83. Brown, D. K. (2000) *Nelson to Vanguard, warship development 1923-1945*, London, Chatham
84. *HMAS Sydney - WT & OT Compartments (As Fitted)* (1935) MP551/1,136AF/41, [Drawing] Canberra, ACT, National Archives Australia
85. Great Britain. Admiralty. (1932) *Specification for building a Cruiser of the 1932 Programme "Leander" Class (Modified) : Part 1 - Hull A. Structural*, London, HMSO
86. *HMAS Sydney, Machinery Information Book* (1935), Wallsend-on-Tyne, Swan, Hunter, Wigham and Richardson Ltd
87. *HMAS Sydney - Hold (As Fitted) - Scale 1/8 Inch = 1 Foot - Plan Reference: 136/8s*, National Archives Australia
88. Great Britain. Admiralty. Ship Department (1962) *Naval marine engineering practice*. 2nd ed. B.R. 3003. Vol. 2, London, HMSO

DSTO-GD-0559

89. HMAS Hobart - Platform Deck - (As Fitted) (1945) M2885,NN5, [Drawing] Canberra, ACT, National Archives Australia
90. Newton, R. N. (1941) *Practical construction of warships*. 1st ed, London, Longmans, Green & Co.
91. HMAS Sydney - Pumping, Flooding & Draining Description (As Fitted.), (1935) MP551/1,136/13AF, [Booklet] Canberra, ACT, National Archives Australia
92. HMAS Sydney - Fresh & Salt Water Services (As Fitted) - Forecastle, Superstructure Decks & Bridges - Scale 1/8 Inch = 1 Foot (1935) National Archives Australia
93. HMAS Sydney - Fresh & Salt Water Services (As Fitted) - Upper & Lower Decks - Scale 1/8 Inch = 1 Foot - Plan Reference: 136/17AF, (1935) National Archives Australia
94. HMAS Sydney - Fresh & Salt Water Services (As Fitted) - Platform & Hold - Scale 1/8 Inch = 1 Foot - Plan Reference: 136/18AF, (1935) National Archives Australia
95. HMAS Sydney - Fresh & Salt Water Services (As Fitted) - Profile & Sections - Scale 1/8 Inch = 1 Foot - Plan Reference: 136/19AF, National Archives Australia
96. HMAS Sydney - Fresh & Salt Water Services Description - (As Fitted) - Plan Reference: 136/20AF, National Archives Australia
97. Finding Sydney Foundation. HMAS Sydney II, Finding Sydney Foundation - Photo gallery - Historical Archive. [Accessed November 2008]; Available from: <http://www.findingsydney.com/gallery.asp>.
98. Great Britain. Admiralty. (1932) *Specification for building a Cruiser of the 1932 Programme "Leander" Class (Modified) : Part 1 - Hull B. general*, London, HMSO
99. HMAS Sydney - Ventilation Arrangements (As Fitted) - Profile & Sections - Scale 1/8 Inch = 1 Foot (1935) MP551/1,136AF/24, [Drawing] Canberra, ACT, National Archives Australia
100. McLaren, H. (1961) Electrical engineering in the Royal Navy. In *Proceedings of the Institution of Electrical Engineers (UK)* London, IEE
101. Great Britain. Naval Electrical Department (1933) *Naval electrical pocket book*. B.R. 157, London, HMSO
102. HMAS Sydney - Instructions for working Sturtevant pneumatic transmission of messages system (As Fitted) (1935) MP551/1,136AF/107, Canberra, ACT, National Archives Australia
103. HMAS Sydney - Transmitting station - Scale 1/2 Inch = 1 Foot (1935) [Drawing] Canberra, ACT, National Archives Australia
104. Johnson, A. G. (2008) Submission concerning HMAS Sydney's wireless telegraphy (W/T) capability. In *HMAS Sydney II Commission of Inquiry* Sydney, NSW:20 July 2008 Commonwealth of Australia (SUBM.001.0001)
105. HMAS Sydney War head room (As fitted), (1935) NAA.099.0001, [Drawing] Canberra, ACT, National Archives Australia
106. "HMAS 'Sydney' - Wallsend Yard - An Account, Shewing the Principal Dimensions of This Ship", National Archives Australia
107. Beauchamp, K. G. (2001) *History of telegraphy*, London, Institution of Electrical Engineers
108. HMAS Sydney - No 1487 - Arrangement of 2nd W/T Office (Type 49) And Lead of Aerial Trunk - Scale 1/2 Inch = 1 Foot & As Shown - Tracing No. 638 - Plan Reference: 136/R16, National Archives Australia
109. HMAS Sydney II - Alterations and Additions, (1941) 603/263/624, Canberra, ACT, National Archive of Australia
110. HMAS Sydney - Wireless Telegraphy Rig, (1935) MP551/1,136AF/59, [Drawing] Canberra, ACT, National Archives Australia
111. Great Britain. Admiralty. (1964) *Admiralty manual of seamanship*. 2nd ed. B.R. 67, London, HMSO



112. *US Patent 734,118 - Life raft* (1903) United States Patent and Trademark Office
113. Ashton, J., Channelor, C. and Courtney, R. (1993) *The scientific investigation of a Carley Float*. Technical papers of the Australian War Memorial, Queanbeyan, NSW, Australian War Memorial
114. *Survival at sea for marines, aviators and search and rescue personnel*, (2008) AG-HFM-152, North Atlantic Treaty Organization (NATO)
115. Carley life rafts - WWII - lifesaving equipment. (2005) *Naval historical review* 26 (12) 19-20
116. Australia. Parliament. Joint Standing Committee on Foreign Affairs Defence and Trade (1999) *Report on the loss of HMAS Sydney*, Canberra, ACT, Commonwealth of Australia
117. Olson, W. J. (1996) *With all hands : a study of the circumstances surrounding the loss of 645 officers and men aboard HMAS Sydney in November 1941* Fremantle, WA, Western Australian Maritime Museum
118. ID P02308.004, [Picture] Canberra, ACT, Australian War Memorial
119. ID P02308.005, [Picture] Canberra, ACT, Australian War Memorial
120. Frame, T. R. (1998) *HMAS Sydney : loss and controversy*, Sydney, NSW, Hodder & Stoughton
121. ID 306663, [Photograph] Canberra, ACT, Australian War Memorial
122. Australia. Royal Australian Navy. Sea Power Centre *Electronic photograph collection*,
123. ID 306661D, [Photograph] Canberra, ACT, Australian War Memorial
124. Radcliffe, R. V. (2008) Interview of Richard Vincent Radcliffe. In *HMAS Sydney II Commission of Inquiry* Melbourne, Vic:25 June 2008 Commonwealth of Australia (TRAN.004.000\_C)
125. ID 301407, [Photograph] Canberra, ACT, Australian War Memorial
126. ID 128094, [Photograph] Canberra, ACT, Australian War Memorial
127. *HMAS Sydney - Boats (including spare gear)*, NAA.090.0014, Canberra, ACT, National Archives Australia
128. Hore, P., (ed.) (2001) *HMAS Sydney II : the cruiser and the controversy in the archives of the United Kingdom*. Papers in Australian maritime affairs No. 9, Canberra, ACT, RAN. Sea Power Centre.
129. Ravenscroft, J. J. (1998) Submission of J. J. Ravenscroft. In *Inquiry into the circumstances of the sinking of HMAS Sydney : transcripts of public hearings 1997-1999*. Joint Standing Committee on Foreign Affairs Defence and Trade. Defence Subcommittee, Canberra, ACT:24 March 1998 Commonwealth of Australia (PINK.SUBS.011.0045)
130. *Secretary Department of the Navy to Captain-in-Charge, HMA Naval Establishments, Sydney "Refitting and Docking Programme 1939 - 1940"*, (1939) MP138/1,603/247/1320, Canberra, ACT, National Archives Australia
131. NEG 20357-1, Sam Hood Collection, Sydney, NSW, Australian National Maritime Museum
132. Navy Department (1945) *Handbook of damage control*, NAVPERS 16191, Washington, D.C., Bureau of Ships
133. Finding Sydney Foundation. *HMAS Sydney II, finding Sydney Foundation - Roll of Honour*. (2008) [Accessed 9 December 2008]; Available from: <http://www.findingsydney.com/roll.asp>.
134. Rush, J. T. (2008) *HMAS Sydney II COI/OUT/2008 - Supplementary instructions*, CORR.009.0010, [Letter] Sydney, NSW, HMAS Sydney II Commission of Inquiry
135. Royal Australian Navy (2004) *SSSS Cerberus standard combat survivability course guide*, DPS No. M4781, [Course Handbook] Canberra, ACT, RAN

DSTO-GD-0559

136. Rushbrook, F. (1979) *Fire aboard : the problems of prevention and control in ships, port installations, and offshore structures*. 2nd ed, Glasgow, Scotland, Brown, Son & Ferguson
137. "HMAS Sydney Pumping, Flooding & Draining Description (As Fitted.) - Plan Reference: 136/13AF", National Archives Australia
138. *HMAS Sydney - Pumping, Flooding & Draining Arrangements (As Fitted) - Forecastle Superstructure Decks & Bridges - Scale 1/8 Inch = 1 Foot*, (1935) MP551/1,136AF/9, [Drawing] Canberra, ACT, National Archives Australia
139. *HMAS Sydney - Pumping, Flooding & Draining Arrangements (As Fitted) - Upper & Lower Decks - Scale 1/8 Inch = 1 Foot*, (1935) MP551/1,136AF/10, [Drawing] Canberra, ACT, National Archives Australia
140. *HMS Phaeton, Body Plan as Laid Off showing Plate Edges, Traces of Longitudinals etc.*, (1935) MP551/1,136/98, [Drawing] Canberra, ACT, National Archives Australia
141. *HMAS Sydney - Fly to Arrgt of Fire & Blge Pump Suction & Discharge Pipes in Forwd Boiler Room Shewing - Modification to Sea Suction Valve - Scale 1/2 Inch = 1 Foot - No 975*, National Archives Australia
142. Custance, W. N. (1939) *Report of Inspection of His Majesty's Ships : inspection of HMA Ship Sydney*, 508/201/505, [Report] Canberra, ACT, National Archives Australia
143. *Walkers Limited, Maryborough, Vic*, (1943) 603/201/981, [Various Papers] Canberra, ACT, National Archives Australia
144. DNC Dept, A., Bath 'HMS Birmingham Torpedo Damage 28th Nov 1943', 5098604, UKAA.001(.001-.024), ADM 267/13, [Report]
145. ID 029571, [Photograph] Canberra, ACT, Australian War Memorial
146. ID 008178, [Photograph] Canberra, ACT, Australian War Memorial
147. *Enclosure to HMAS "Hobart" Letter No. 9386/177/166 dated 25th August 1943 : Section 1 - C.A.F.O 2489/42, paragraph 12. 12. Narrative of events*, (1943) [Letter] Canberra, ACT, National Archives Australia
148. *HSK Kormoran showing armament*, EXH.016.0001, [Drawing] Sydney, NSW, HMAS Sydney II Commission of Inquiry
149. Detmers, T. (1973) *The raider Kormoran*, London, Tandem Books
150. Campbell, J. (1998) *Jutland : an analysis of the fighting*, London, Conway Maritime Press
151. A report on the WWII German 37-mm flak gun. (1943) *Tactical and Technical Trends* (39) 2 December 1943
152. Montgomery, M. (1991) *The Sydney-Kormoran Action 19/11/41 : contradiction between the evidence and the official account*. In *Papers from the HMAS Sydney Forum* Fremantle, WA:21-23 November 1991 Western Australian Maritime Museum
153. McDonald, G. (2005) *Seeking the Sydney : a quest for truth*, Perth, WA, University of Western Australia Press
154. Olson, W. (2000) *Bitter victory - the death of HMAS Sydney*, Nedlands, WA, University of West Australia Press
155. Schmalenbach, P. (1979) *German raiders: a history of auxiliary cruisers of the German Navy, 1895-1945*, Annapolis, Md, Naval Institute Press
156. FSF.006.0082 (2008) [Photograph] Perth, WA, Finding Sydney Foundation
157. FSF.006.0083 (2008) [Photograph] Perth, WA, Finding Sydney Foundation
158. FSF.006.0084 (2008) [Photograph] Perth, WA, Finding Sydney Foundation
159. *Drawing of HSK Kormoran*, [Drawing], EXH.016.0001
160. FSF.006.0100 (2008) [Photograph] Perth, WA, Finding Sydney Foundation
161. FSF.006.0136 (2008) [Photograph] Perth, WA, Finding Sydney Foundation

162. FSF.006.0104 (2008) [Photograph] Perth, WA, Finding Sydney Foundation
163. FSF.006.0115 (2008) [Photograph] Perth, WA, Finding Sydney Foundation
164. FSF.006.0011 (2008) [Photograph] Perth, WA, Finding Sydney Foundation
165. FSF.006.0074 (2008) [Photograph] Perth, WA, Finding Sydney Foundation
166. FSF.006.0030 (2008) [Photograph] Perth, WA, Finding Sydney Foundation
167. FSF.006.0076 (2008) [Photograph] Perth, WA, Finding Sydney Foundation
168. US Navy Department (1945) *Mine identification manual (Second revision)*, Ordnance pamphlet 898, US Navy Department
169. Perryman, J. (2008) *Report on the search for the wrecks of HMAS Sydney (II) & HSK Kormoran*, CORR.005.0093, Sydney, NSW, HMAS Sydney II Commission of Inquiry
170. Electric Pictures (Firm), et al. (2008) *The hunt for HMAS Sydney* [Videorecording] Sydney, NSW, Film Australia
171. FSF.004.0218 (2008) [Photograph] Perth, WA, Finding Sydney Foundation
172. FSF.004.0244 (2008) [Photograph] Perth, WA, Finding Sydney Foundation
173. FSF.004.0260 (2008) [Photograph] Perth, WA, Finding Sydney Foundation
174. Yarnall, P. R. *Cruiser photo index CL-49 USS St. LOUIS* (2008) Updated 15 December 2008 [Accessed 22 December 2008]; Available from: <http://www.navsource.org/archives/04/049/04049.htm>.
175. FSF.004.0239 (2008) [Photograph] Perth, WA, Finding Sydney Foundation
176. FSF.002.0057 (2008) [Photograph] Perth, WA, Finding Sydney Foundation
177. FSF.002.0022 (2008) [Photograph] Perth, WA, Finding Sydney Foundation
178. FSF.002.0003 (2008) [Photograph] Perth, WA, Finding Sydney Foundation
179. FSF.002.0221 (2008) [Photograph] Perth, WA, Finding Sydney Foundation
180. FSF.004.0022 (2008) [Photograph] Perth, WA, Finding Sydney Foundation
181. FSF.003.0014 (2008) [Photograph] Perth, WA, Finding Sydney Foundation
182. FSF.002.0313 (2008) [Photograph] Perth, WA, Finding Sydney Foundation
183. FSF.003.0020 (2008) [Photograph] Perth, WA, Finding Sydney Foundation
184. FSF.002.0308 (2008) [Photograph] Perth, WA, Finding Sydney Foundation
185. FSF.003.0010 (2008) [Photograph] Perth, WA, Finding Sydney Foundation
186. FSF.002.0312 (2008) [Photograph] Perth, WA, Finding Sydney Foundation
187. FSF.002.0319 (2008) [Photograph] Perth, WA, Finding Sydney Foundation
188. FSF.002.0321 (2008) [Photograph] Perth, WA, Finding Sydney Foundation
189. FSF.002.0322 (2008) [Photograph] Perth, WA, Finding Sydney Foundation
190. FSF.003.0009 (2008) [Photograph] Perth, WA, Finding Sydney Foundation
191. FSF.002.0309 (2008) [Photograph] Perth, WA, Finding Sydney Foundation
192. FSF.002.0311 (2008) [Photograph] Perth, WA, Finding Sydney Foundation
193. FSF.002.0324 (2008) [Photograph] Perth, WA, Finding Sydney Foundation
194. FSF.002.0105 (2008) [Photograph] Perth, WA, Finding Sydney Foundation
195. FSF.001.0076 (2008) [Photograph] Perth, WA, Finding Sydney Foundation
196. FSF.002.0121 (2008) [Photograph] Perth, WA, Finding Sydney Foundation
197. FSF.002.0219 (2008) [Photograph] Perth, WA, Finding Sydney Foundation
198. FSF.002.0127 (2008) [Photograph] Perth, WA, Finding Sydney Foundation
199. FSF.002.0126 (2008) [Photograph] Perth, WA, Finding Sydney Foundation
200. FSF.001.0069 (2008) [Photograph] Perth, WA, Finding Sydney Foundation
201. FSF.003.0012 (2008) [Photograph] Perth, WA, Finding Sydney Foundation
202. FSF.002.0140 (2008) [Photograph] Perth, WA, Finding Sydney Foundation
203. FSF.002.0144 (2008) [Photograph] Perth, WA, Finding Sydney Foundation
204. FSF.002.0296 (2008) [Photograph] Perth, WA, Finding Sydney Foundation
205. FSF.002.0297 (2008) [Photograph] Perth, WA, Finding Sydney Foundation
206. FSF.002.0157 (2008) [Photograph] Perth, WA, Finding Sydney Foundation

DSTO-GD-0559

207. FSF.002.0154 (2008) [Photograph] Perth, WA, Finding Sydney Foundation
208. FSF.001.0046 (2008) [Photograph] Perth, WA, Finding Sydney Foundation
209. FSF.001.0043 (2008) [Photograph] Perth, WA, Finding Sydney Foundation
210. FSF.002.0163 (2008) [Photograph] Perth, WA, Finding Sydney Foundation
211. FSF.004.0073 (2008) [Photograph] Perth, WA, Finding Sydney Foundation
212. FSF.004.0122 (2008) [Photograph] Perth, WA, Finding Sydney Foundation
213. FSF.004.0128 (2008) [Photograph] Perth, WA, Finding Sydney Foundation
214. FSF.002.0258 (2008) [Photograph] Perth, WA, Finding Sydney Foundation
215. FSF.003.0026 (2008) [Photograph] Perth, WA, Finding Sydney Foundation
216. FSF.003.0027 (2008) [Photograph] Perth, WA, Finding Sydney Foundation
217. FSF.003.0028 (2008) [Photograph] Perth, WA, Finding Sydney Foundation
218. FSF.003.0034 (2008) [Photograph] Perth, WA, Finding Sydney Foundation
219. FSF.003.0032 (2008) [Photograph] Perth, WA, Finding Sydney Foundation
220. FSF.002.0184 (2008) [Photograph] Perth, WA, Finding Sydney Foundation
221. FSF.002.0180 (2008) [Photograph] Perth, WA, Finding Sydney Foundation
222. FSF.002.0181 (2008) [Photograph] Perth, WA, Finding Sydney Foundation
223. FSF.001.0015 (2008) [Photograph] Perth, WA, Finding Sydney Foundation
224. FSF.001.0013 (2008) [Photograph] Perth, WA, Finding Sydney Foundation
225. FSF.002.0192 (2008) [Photograph] Perth, WA, Finding Sydney Foundation
226. FSF.002.0185 (2008) [Photograph] Perth, WA, Finding Sydney Foundation
227. FSF.002.0183 (2008) [Photograph] Perth, WA, Finding Sydney Foundation
228. FSF.004.0090 (2008) [Photograph] Perth, WA, Finding Sydney Foundation
229. FSF.004.0096 (2008) [Photograph] Perth, WA, Finding Sydney Foundation
230. FSF.004.0083 (2008) [Photograph] Perth, WA, Finding Sydney Foundation
231. FSF.004.0153 (2008) [Photograph] Perth, WA, Finding Sydney Foundation
232. FSF.004.0147 (2008) [Photograph] Perth, WA, Finding Sydney Foundation
233. FSF.004.0162 (2008) [Photograph] Perth, WA, Finding Sydney Foundation
234. FSF.004.0156 (2008) [Photograph] Perth, WA, Finding Sydney Foundation
235. Lavender, G. C. (2008) Interview of Gordon Clair Lavender. In *HMAS Sydney II Commission of Inquiry* Fremantle, WA:24 June 2008 Commonwealth of Australia (TRAN.003.0006\_C)
236. *Hull Specification for a 35-Foot Motor Pinnace and 35-Foot Motor Barge (Admiral's)*, (1932) NAA.090.0017, [Drawing] Canberra, ACT, National Archives Australia
237. FSF.004.0326 (2008) [Photograph] Perth, WA, Finding Sydney Foundation
238. FSF.004.0334 (2008) [Photograph] Perth, WA, Finding Sydney Foundation
239. FSF.004.0337 (2008) [Photograph] Perth, WA, Finding Sydney Foundation
240. FSF.004.0330 (2008) [Photograph] Perth, WA, Finding Sydney Foundation
241. FSF.004.0344 (2008) [Photograph] Perth, WA, Finding Sydney Foundation
242. FSF.004.0398 (2008) [Photograph] Perth, WA, Finding Sydney Foundation
243. FSF.004.0404 (2008) [Photograph] Perth, WA, Finding Sydney Foundation
244. FSF.004.0407 (2008) [Photograph] Perth, WA, Finding Sydney Foundation
245. FSF.003.0007 (2008) [Photograph] Perth, WA, Finding Sydney Foundation
246. FSF.003.0041 (2008) [Photograph] Perth, WA, Finding Sydney Foundation
247. FSF.001.0045 (2008) [Photograph] Perth, WA, Finding Sydney Foundation
248. FSF.001.0054 (2008) [Photograph] Perth, WA, Finding Sydney Foundation
249. FSF.002.0135 (2008) [Photograph] Perth, WA, Finding Sydney Foundation
250. FSF.002.0225 (2008) [Photograph] Perth, WA, Finding Sydney Foundation
251. FSF.002.0056 (2008) [Photograph] Perth, WA, Finding Sydney Foundation
252. Ballard, R. (1993) *Lost ships of Guadalcanal*, St Leonards, NSW, Allen & Unwin
253. FSF.003.0030 (2008) [Photograph] Perth, WA, Finding Sydney Foundation
254. FSF.002.0194 (2008) [Photograph] Perth, WA, Finding Sydney Foundation

255. FSF.002.0238 (2008) [Photograph] Perth, WA, Finding Sydney Foundation
256. FSF.002.0255 (2008) [Photograph] Perth, WA, Finding Sydney Foundation
257. FSF.002.0242 (2008) [Photograph] Perth, WA, Finding Sydney Foundation
258. FSF.002.0203 (2008) [Photograph] Perth, WA, Finding Sydney Foundation
259. FSF.002.0331 (2008) [Photograph] Perth, WA, Finding Sydney Foundation
260. FSF.002.0020 (2008) [Photograph] Perth, WA, Finding Sydney Foundation
261. FSF.002.0104 (2008) [Photograph] Perth, WA, Finding Sydney Foundation
262. FSF.002.0026 (2008) [Photograph] Perth, WA, Finding Sydney Foundation
263. FSF.002.0182 (2008) [Photograph] Perth, WA, Finding Sydney Foundation
264. FSF.002.0327 (2008) [Photograph] Perth, WA, Finding Sydney Foundation
265. FSF.002.0152 (2008) [Photograph] Perth, WA, Finding Sydney Foundation
266. FSF.002.0179 (2008) [Photograph] Perth, WA, Finding Sydney Foundation
267. FSF.002.0280 (2008) [Photograph] Perth, WA, Finding Sydney Foundation
268. FSF.002.0196 (2008) [Photograph] Perth, WA, Finding Sydney Foundation
269. FSF.002.0175 (2008) [Photograph] Perth, WA, Finding Sydney Foundation
270. FSF.002.0281 (2008) [Photograph] Perth, WA, Finding Sydney Foundation
271. FSF.002.0270 (2008) [Photograph] Perth, WA, Finding Sydney Foundation
272. FSF.002.0283 (2008) [Photograph] Perth, WA, Finding Sydney Foundation
273. FSF.002.0318 (2008) [Photograph] Perth, WA, Finding Sydney Foundation
274. FSF.002.0122 (2008) [Photograph] Perth, WA, Finding Sydney Foundation
275. FSF.002.0170 (2008) [Photograph] Perth, WA, Finding Sydney Foundation
276. FSF.003.0039 (2008) [Photograph] Perth, WA, Finding Sydney Foundation
277. FSF.005.0243 (2008) [Photograph] Perth, WA, Finding Sydney Foundation
278. FSF.005.0239 (2008) [Photograph] Perth, WA, Finding Sydney Foundation
279. FSF.005.0236 (2008) [Photograph] Perth, WA, Finding Sydney Foundation
280. FSF.004.0363 (2008) [Photograph] Perth, WA, Finding Sydney Foundation
281. FSF.004.0377 (2008) [Photograph] Perth, WA, Finding Sydney Foundation
282. FSF.004.0353 (2008) [Photograph] Perth, WA, Finding Sydney Foundation
283. HMAS Sydney II Commission of Inquiry (2008) *DSTO assumptions : the course of the interception and encounter between HMAS Sydney and Kormoran*, [Correspondence] Sydney, NSW, HMAS Sydney II Commission of Inquiry,
284. *German explosive ordnance (projectiles and projectile fuzes)*, (1953) TM 9-1985-2/TO 39B-1A-9, Washington, US Departments of the Army and the Air Force
285. Walsh, B. E., Burman, N. M. and Buckland, M. E. (1996) *Ship Survivability Enhancement Program (SSEP) - manual of conventional weapons data* DSTO-GD-0105, Melbourne, Vic., Defence Science and Technology Organisation (DSTO)
286. Mallinson, A. (2007) *Man of War*, London, Bantam Press
287. *Example No. 1 - Attack - 750 Lbs Warhead at 25 BKD*, National Archives Australia
288. FSF.002.0114 (2008) [Photograph] Perth, WA, Finding Sydney Foundation
289. FSF.002.0120 (2008) [Photograph] Perth, WA, Finding Sydney Foundation
290. Detmers, T. (1959) *The raider Kormoran*, London, William Kimber
291. FSF.002.0095 (2008) [Photograph] Perth, WA, Finding Sydney Foundation
292. FSF.002.0153 (2008) [Photograph] Perth, WA, Finding Sydney Foundation
293. FSF.002.0113 (2008) [Photograph] Perth, WA, Finding Sydney Foundation
294. FSF.002.0217 (2008) [Photograph] Perth, WA, Finding Sydney Foundation
295. FSF.002.0214 (2008) [Photograph] Perth, WA, Finding Sydney Foundation
296. *SFPE handbook of fire protection engineering* (1995). 2nd ed, Quincy, Mass., National Fire Protection Association / Society of Fire Protection Engineers
297. *HMAS Sydney II - Alterations and Additions* (1937) MP138/1,603/263/418, [Letter] Canberra, ACT, National Archives Australia

DSTO-GD-0559

298. Wikipedia. *Siebe Gorman Salvus*. [Accessed 4 December 2008]; Available from: [http://en.wikipedia.org/wiki/Siebe\\_Gorman\\_Salvus](http://en.wikipedia.org/wiki/Siebe_Gorman_Salvus)
299. ID 029574, [Photograph] Canberra, ACT, Australian War Memorial
300. Kennett, S. R. (1998) *Estimation of response times for fire fighting personnel on a naval vessel*, DSTO-TN-0165, Melbourne, Vic., Defence Science and Technology Organisation (DSTO)
301. FSF.002.0065 (2008) [Photograph] Perth, WA, Finding Sydney Foundation
302. FSF.005.0011 (2008) [Photograph] Perth, WA, Finding Sydney Foundation
303. FSF.002.0033 (2008) [Photograph] Perth, WA, Finding Sydney Foundation
304. FSF.002.0264 (2008) [Photograph] Perth, WA, Finding Sydney Foundation
305. FSF.002.0267 (2008) [Photograph] Perth, WA, Finding Sydney Foundation
306. FSF.005.0244 (2008) [Photograph] Perth, WA, Finding Sydney Foundation
307. FSF.002.0288 (2008) [Photograph] Perth, WA, Finding Sydney Foundation
308. FSF.002.0300 (2008) [Photograph] Perth, WA, Finding Sydney Foundation
309. FSF.002.0303 (2008) [Photograph] Perth, WA, Finding Sydney Foundation
310. FSF.002.0208 (2008) [Photograph] Perth, WA, Finding Sydney Foundation
311. FSF.002.0293 (2008) [Photograph] Perth, WA, Finding Sydney Foundation
312. FSF.002.0195 (2008) [Photograph] Perth, WA, Finding Sydney Foundation
313. Gudze, M. and Morris, B. (2008) *Rapid residual longitudinal strength assessment for ANZAC ship stability software*, To be Published, Melbourne, Vic, Defence Science and Technology Organisation (DSTO)
314. Muckle, W. (1967) *Strength of ships' structures*, London, Edward Arnold
315. Foster-King, J. (1916) Strength of watertight bulkheads. *Trans RINA*
316. Young, W. C. (1989) *Roark's formulas for stress and strain*. 6th ed, New York, McGraw-Hill
317. "Modified 'Leander' Class ('Amphion', 'Apollo' & 'Phaeton') - Transverse Bulkheads 35 & 73 - Scale 1/2 Inch to One Foot & As Shewn", National Archives Australia
318. Shigley, J. E. (1986) *Mechanical engineering design*. First metric ed, New York, McGraw-Hill
319. DEF (AUST) 5000 ADF Maritime Materiel Requirements Set : Volume 3 : Part 6 : Seakeeping, (2003) Canberra, ACT, Australia. Department of Defence. Royal Australian Navy
320. Courtney, J. (Unknown) *Report on the meteorological conditions near 26S 111E for 17-28 November 1941*, WAM.002.0049, Sydney, NSW, HMAS Sydney II Commission of Inquiry
321. National Archives Australia. *The sinking of HMAS Sydney : 3. The search and rescue*. [Accessed 28 April 2008]; Available from: [http://www.naa.gov.au/naaresources/publications/research\\_guides/guides/sydney/pages/chapter03.htm](http://www.naa.gov.au/naaresources/publications/research_guides/guides/sydney/pages/chapter03.htm).
322. de la Rue, H. F. *On air operations conducted by RAAF Western Area 24th - 29th November 1941 in the connection with the loss of HMAS Sydney*, NAA.018.0251, [Correspondence] Canberra, ACT, National Archives Australia
323. Australia. Parliament. Joint Standing Committee on Foreign Affairs Defence and Trade. Defence Sub-Committee (1999) *Inquiry into the circumstances of the sinking of HMAS Sydney : transcripts of public hearings 1997-1999*. Vol. v. 1-8. Submissions - v. 9 Canberra, ACT, Defence Sub-Committee
324. McArthur, T. (2001) *A rush to judgement (Ph. D Thesis)*, Toowoomba, Qld., University of Southern Queensland
325. *Points of recent Carnarvon operation, December 1941*, NAA.018.0207, Canberra, ACT, National Archives Australia

326. Kirsner, K. (1992) *HSK Kormoran versus HMAS Sydney : converging operations in historical analysis*, Nedlands, WA, University of Western Australia
327. Southern, B. (1991) Climatology of weather conditions W.A. West Coast in November 1941. In *Papers from the HMAS Sydney Forum* Fremantle, WA:21-23 November 1991 Western Australian Maritime Museum
328. Penrose, J. and Klaka, K. (1991) Notes on the movement of wreck material from the area of the Sydney/Kormoran engagement. In *Papers from the HMAS Sydney Forum* Fremantle, WA:21-23 November 1991 Western Australian Maritime Museum
329. NSMRL *SEE/RESCUE Project target detection probability testing, modeling and analysis - final report*, (2006) Report CG-D-02-06, Washington, DC, US Coast Guard Research and Development Centre
330. Critchley, M. (1943) *Shipwreck survivors : a medical study*, London, J & A Churchill
331. Allen, M. (2006) Survival modeling and SAROPS. *On Scene : journal of the US Coast Guard* Fall 2006
332. Tikuisis, P. (1997) Prediction of survival times at sea based on observed body cooling rates. *Aviation, Space and Environmental Medicine* **68** (5) 441-448
333. Haywood, J., (1983) The physiology of immersion hypothermia. In: Pozos, R. S. and Wittmers, L. E., eds *The nature of treatment of hypothermia*. Minneapolis, Minn., University of Minnesota Press,
334. *NODC (Levitus) World Ocean Atlas* (1998), Boulder, Colorado, NOAA-CIRES Climate Diagnostic Centre
335. Stafford, B. (2008) *The sinking and rising of drowned bodies ; personal communication* Flinstone, MD, Maryland Natural Resources Police
336. Pounder, D. *Bodies from water : lecture notes*. (1992) Updated 5 July 2006 [Accessed 12 October 2008]; Available from: , <http://www.dundee.ac.uk/forensicmedicine/notes/water.pdf>
337. *Ocean views from LEVITIUS94 : annual*. [Accessed 23 November 2008]; Available from: <http://ingrid.ldgo.columbia.edu/SOURCES/.LEVITIUS94/oceanviews2.html>.
338. Browning, W. J., et al. (1995) *Effect of mortality on search effectiveness*, Report No. CG-D-96, US Department of Transportation / US Coast Guard, Office of Engineering, Logistics and Development
339. *FSF.001.0074* (2008) [Photograph] Perth, WA, Finding Sydney Foundation
340. *Finding Sydney Foundation ROV Footage - HMAS Sydney II - Dive 1* (2008) [Video] Perth, WA, Finding Sydney Foundation
341. *FSF.002.0092* (2008) [Photograph] Perth, WA, Finding Sydney Foundation
342. *FSF.002.0218* (2008) [Photograph] Perth, WA, Finding Sydney Foundation
343. *Finding Sydney Foundation ROV Footage - HMAS Sydney II - Dive 2* (2008) [Video] Perth, WA, Finding Sydney Foundation
344. *Fire in victualising store on HMAS Goorangai*, (1939) MP150/1,674/203/78, [Report] Canberra, ACT, National Archives Australia
345. *FSF.002.0112* (2008) [Photograph] Perth, WA, Finding Sydney Foundation
346. *FSF.002.0206* (2008) [Photograph] Perth, WA, Finding Sydney Foundation
347. *FSF.002.0124* (2008) [Photograph] Perth, WA, Finding Sydney Foundation
348. *FSF.001.0044* (2008) [Photograph] Perth, WA, Finding Sydney Foundation
349. *FSF.004.0078* (2008) [Photograph] Perth, WA, Finding Sydney Foundation
350. *FSF.004.0079* (2008) [Photograph] Perth, WA, Finding Sydney Foundation
351. *FSF.001.0077* (2008) [Photograph] Perth, WA, Finding Sydney Foundation
352. *FSF.002.0103* (2008) [Photograph] Perth, WA, Finding Sydney Foundation
353. *FSF.002.0213* (2008) [Photograph] Perth, WA, Finding Sydney Foundation

DSTO-GD-0559

354. *FSF.006.0012* (2008) [Photograph] Perth, WA, Finding Sydney Foundation
355. *FSF.002.0212* (2008) [Photograph] Perth, WA, Finding Sydney Foundation
356. *FSF.002.0128* (2008) [Photograph] Perth, WA, Finding Sydney Foundation
357. *FSF.002.0131* (2008) [Photograph] Perth, WA, Finding Sydney Foundation
358. *FSF.001.0053* (2008) [Photograph] Perth, WA, Finding Sydney Foundation
359. *FSF.002.0263* (2008) [Photograph] Perth, WA, Finding Sydney Foundation
360. *FSF.002.0137* (2008) [Photograph] Perth, WA, Finding Sydney Foundation
361. *FSF.002.0034* (2008) [Photograph] Perth, WA, Finding Sydney Foundation
362. *FSF.002.0314* (2008) [Photograph] Perth, WA, Finding Sydney Foundation
363. *Finding Sydney Foundation ROV Footage - HMAS Sydney II - Dive 3* (2008) [Video] Perth, WA, Finding Sydney Foundation
364. *FSF.002.0307* (2008) [Photograph] Perth, WA, Finding Sydney Foundation
365. *FSF.003.0008* (2008) [Photograph] Perth, WA, Finding Sydney Foundation
366. *FSF.005.0234* (2008) [Photograph] Perth, WA, Finding Sydney Foundation
367. *FSF.004.0031* (2008) [Photograph] Perth, WA, Finding Sydney Foundation
368. *FSF.002.0029* (2008) [Photograph] Perth, WA, Finding Sydney Foundation
369. *FSF.002.0052* (2008) [Photograph] Perth, WA, Finding Sydney Foundation
370. *FSF.002.0325* (2008) [Photograph] Perth, WA, Finding Sydney Foundation
371. *FSF.002.0306* (2008) [Photograph] Perth, WA, Finding Sydney Foundation
372. *FSF.002.0304* (2008) [Photograph] Perth, WA, Finding Sydney Foundation
373. *FSF.002.0301* (2008) [Photograph] Perth, WA, Finding Sydney Foundation
374. *FSF.002.0298* (2008) [Photograph] Perth, WA, Finding Sydney Foundation
375. *FSF.002.0291* (2008) [Photograph] Perth, WA, Finding Sydney Foundation
376. *FSF.002.0289* (2008) [Photograph] Perth, WA, Finding Sydney Foundation
377. *FSF.002.0284* (2008) [Photograph] Perth, WA, Finding Sydney Foundation
378. *FSF.004.0194* (2008) [Photograph] Perth, WA, Finding Sydney Foundation
379. *FSF.002.0282* (2008) [Photograph] Perth, WA, Finding Sydney Foundation
380. *FSF.002.0272* (2008) [Photograph] Perth, WA, Finding Sydney Foundation
381. *FSF.002.0278* (2008) [Photograph] Perth, WA, Finding Sydney Foundation



DSTO-GD-0559

## Appendix A: HMAS *Sydney* COI 2008

### A.1. Survey of Shell and Fragment Damage to HMAS *Sydney*

#### A.1.1 Numbering Convention used in weapon damage survey

The damage on *Sydney* has been catalogued and a number has been given to each damage location thought to be caused by shell or fragment damage that is considered to be significant. The following defines the numbering scheme.

| Location      | Ship Level               | Penetration | Class            | Index      |
|---------------|--------------------------|-------------|------------------|------------|
| P - Port      | 03 - Upper Bridge        | F - Full    | A - Hole > 15 cm | xx - Index |
| S - Starboard | 02 - Lower Bridge        | P - Partial | B - Hole ~ 15 cm |            |
|               | 01 - Superstructure deck | N - None    | C - Hole < 15 cm |            |
|               | 1 - Forecastle deck      |             |                  |            |
|               | 2 - Upper deck           |             |                  |            |
|               | 3 - Lower deck           |             |                  |            |
|               | 4 - Platform deck        |             |                  |            |
|               | 5 - Hold                 |             |                  |            |

The damage number is given in the form S1FA01. This indicates a hole on the starboard side of the ship, on Forecastle deck, with full penetration, greater than 15 cm and with an index number '01'.

#### A.1.2 Shell and Fragment Damage Description

The following section provides a description of the damage to *Sydney*, including images of the holes and approximate measurements of the holes in *Sydney* based on the size of surrounding features. A detailed account of the method used to measure the holes in *Sydney* is provided in Chapter 2. The measurements presented here are approximations only and will have a tolerance of  $\pm 1$  inch ( $\pm 25$  mm). The measurements have been made to provide input into the flooding analysis model of *Sydney*, and to provide an indication of the size of the weapon that would have caused the hole. Diagrams of the location of the shell and fragment hit locations can be found in Chapter 6.

It is not possible to identify the order in which shell and fragment damage occurred from the images. The damage has been presented (approximately) in the order that the damage appears along the ship and hole size, with the port side damage first and the starboard side damage second.

*This page intentionally blank*

DSTO-CID-0559

A.1.3 Shell and Torpedo damage to HMAS Sydney

Figure 284 and Figure 285 present the damage to Sydney due to shell and torpedo damage.

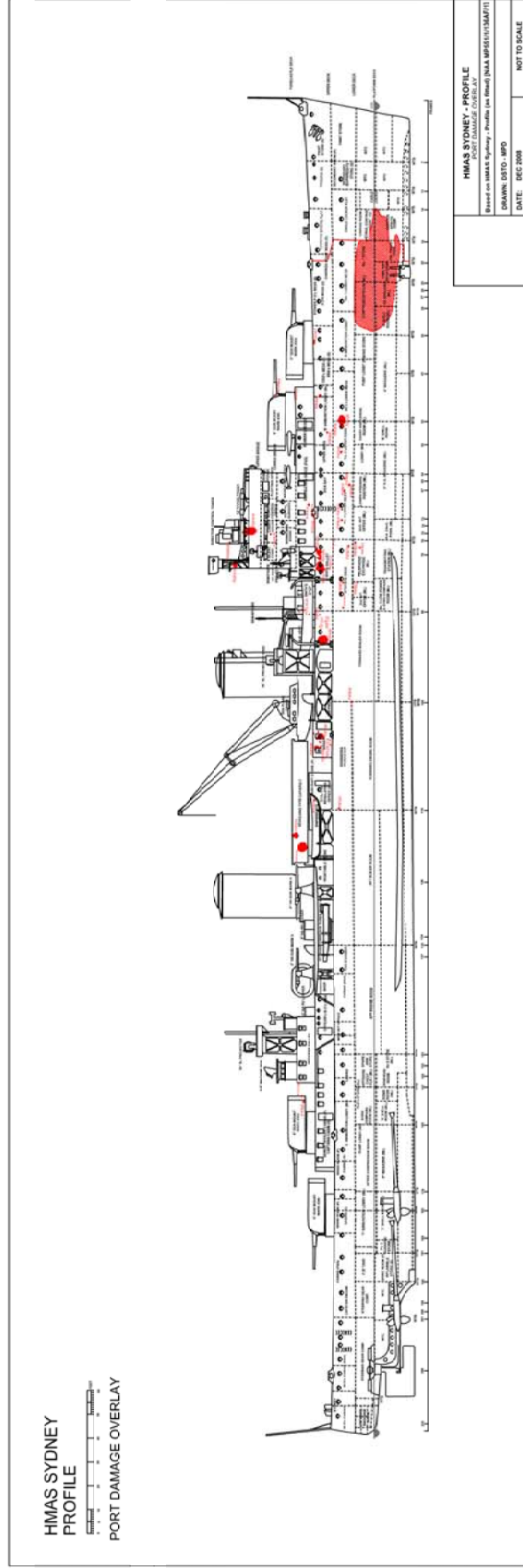

Figure 284: Damage to HMAS Sydney on port side

*This page intentionally blank*

DSTO-CID-0559

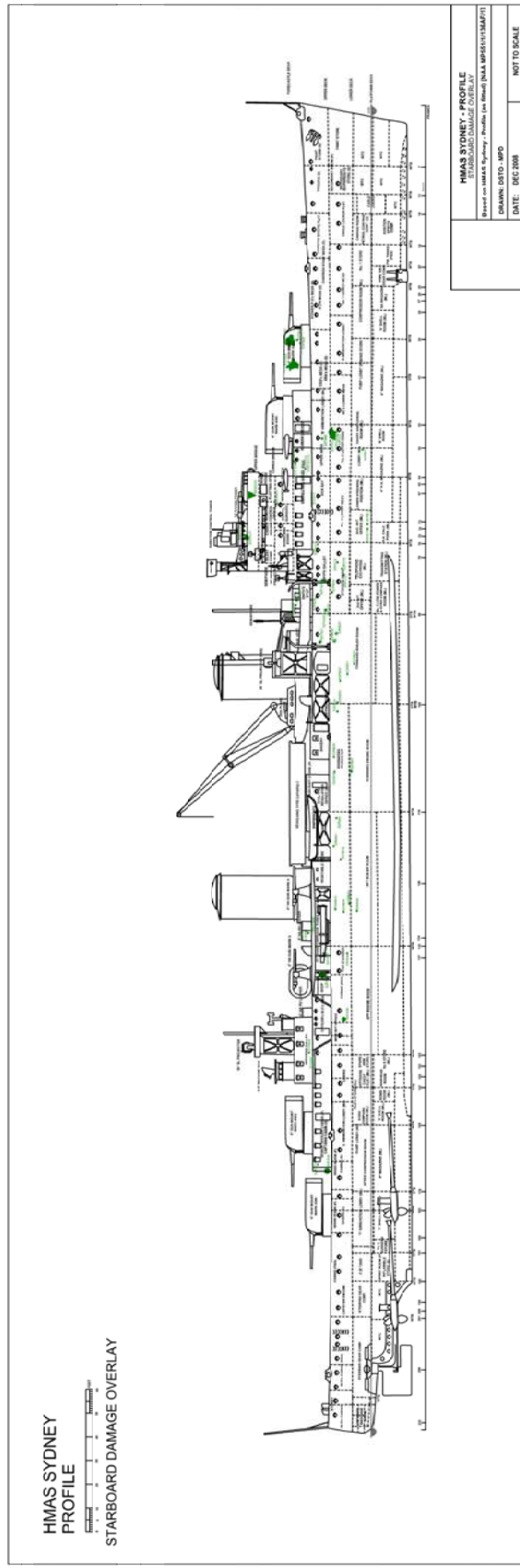

Figure 285: Damage to HMAS Sydney on starboard side

*This page intentionally blank*

DSTO-GD-0559

#### A.1.4 Port side damage – Class A Damage

##### P2FA01

Image : FSF.001.0074 (see Figure 286)  
 Location : Upper deck, CPO's Mess (see Figure 125)  
 Side : Port  
 Probable Cause : Shell Penetration  
 Probable Weapon : 15 cm HE Shell  
 Hull Thickness : 20 lbs (12.7 mm)

The shell possibly came from an angle, leading to an elongated shaped hole. There is also a hole in the deck near this penetration that is probably associated with this shell detonating inside *Sydney*. This damage to the deck can be found in the video footage. This penetration is also just aft of the section of the hull plate that has been bent back at 90° as a result of the bow breaking off. The bend in the hull plate is visible on the left hand side of Figure 286.



Figure 286: In vicinity of CPO's Mess, Upper deck on port side [339]

##### P2FA04

Image : Screen capture from FSF Dive 2 File 101 (see Figure 287)  
 Location : Upper deck, CPO's Mess (see Figure 125)  
 Side : Port  
 Probable Cause : External shell contact detonation  
 Probable Weapon : 15 cm HE Shell  
 Hull Thickness : 25 lbs (15.9 mm)

This hole has a diameter of at least 1' (300 mm) (approx.) and is possibly due to the contact detonation of a 15 cm HE Shell on the hull. This damage has opened the hull at the CPO's Mess on upper deck. Figure 287 was captured from the ROV dive video footage. This detonation would have thrown a lot of fragments into the CPO's mess.

DSTO-GD-0559

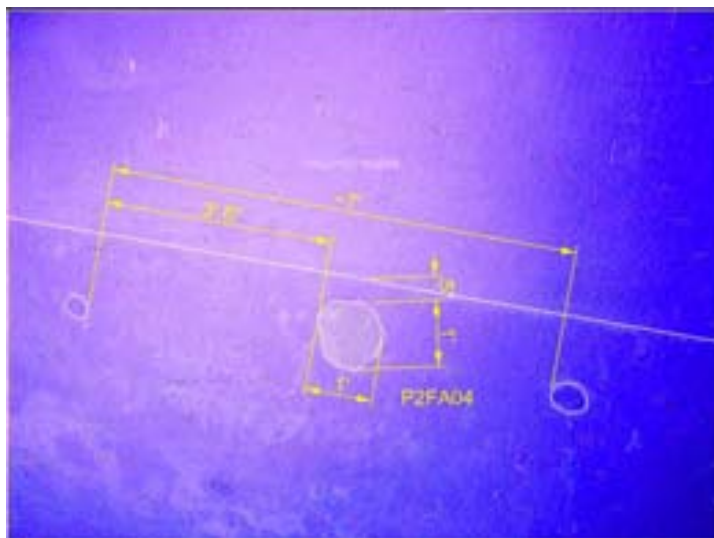

Figure 287: In vicinity of CPO's Mess, upper deck on port side. [340]

#### P1FA05

Image : FSF.002.0092 (see Figure 288)  
 Location : Forecastle deck, Seaman's Urinals (see Figure 125)  
 Side : Port  
 Probable Cause : External shell contact detonation  
 Probable Weapon : 15 cm HE Shell

This is a 6' x 2' (1800 x 600 mm) (approx.) hole into the deck below B turret. It is possible that this hole was caused by the hit at P01FB03 by a 15 cm HE Shell that did not penetrate the B turret, which subsequently fell to the deck before detonating. As this damage is in the vicinity of the roller bearing path it is possible that this damage resulted in the turret jamming. The damage associated with this hole would have been caused by fragments from the detonation of a 15 cm HE Shell. It is worth noting that the view ports on B turret are open.



Figure 288: From port side showing B Turret [341]



DSTO-GD-0559

**P3FA06**

Image : FSF.002.0218 (see Figure 289)  
 Location : Lower deck, No. 2 and No. 3 Lower Mess (see Figure 125)  
 Side : Port  
 Probable Cause : External shell contact detonation  
 Probable Weapon : 15 cm HE Shell  
 Hull Thickness : 25 lbs (15.9 mm)

This is a 6' x 3' (1800 x 900 mm) hole into the port side of the ship at Lower deck level. This is likely to be a surface contact detonation of a 15 cm HE Shell, and has opened a hole in the No. 2 and No. 3 Lower Mess areas. This damage has also resulted in the breach of WTB 53 at this level; this bulkhead is clearly visible inside the hole. The odd shape of the hole on the left hand side is due to the damage meeting up with a scuttle into the No. 3 Mess. There would have been considerable fragment damage inside the No. 2 and No. 3 Mess areas from this detonation.

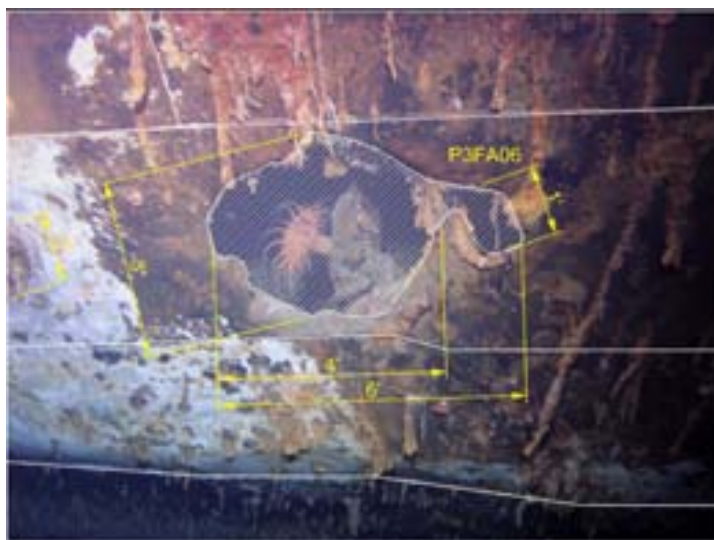

Figure 289: In vicinity of No. 2 and No. 3 Lower Mess, Lower deck [342]

**P3FA08**

Image : Screen capture from FSF Dive 2 File 100 (see Figure 290)  
 Location : Lower deck, Lower No. 3 Mess (see Figure 125)  
 Side : Port  
 Probable Cause : Shell Penetration  
 Probable Weapon : 15 cm HE Shell  
 Hull Thickness : 25 lbs (15.9 mm)

This hole is likely to be due to a shell penetrating the hull at an angle.

DSTO-GD-0559



Figure 290: In vicinity of Lower No. 3 Mess, Lower deck. [343]

**NOTE:** The index A09 has not been used.

**P1FA12**

Image : Screen capture from FSF Dive 1 File 52 (see Figure 291)  
 Location : Damage to Forecastle deck. Into upper deck, Prov. Issue Room and Victualling Office (see Figure 126)  
 Side : Port  
 Probable Cause : Weapon Damage/Fire Damage  
 Probable Weapon : At least 15 cm HE Shell

This hole in the Forecastle deck is directly above the General and Victualling stores on the upper deck. This is a 2' 6" x 1' 6" (750 x 450 mm) hole, possibly caused by a shell detonating on or below the deck. It is possible that this damage is related to similar damage on the starboard side of the ship (S1FA11). It should be noted that the Victualling Store was used to store flour and dried food and was particularly prone to fire damage due to the dry stores [344].

DSTO-GD-0559

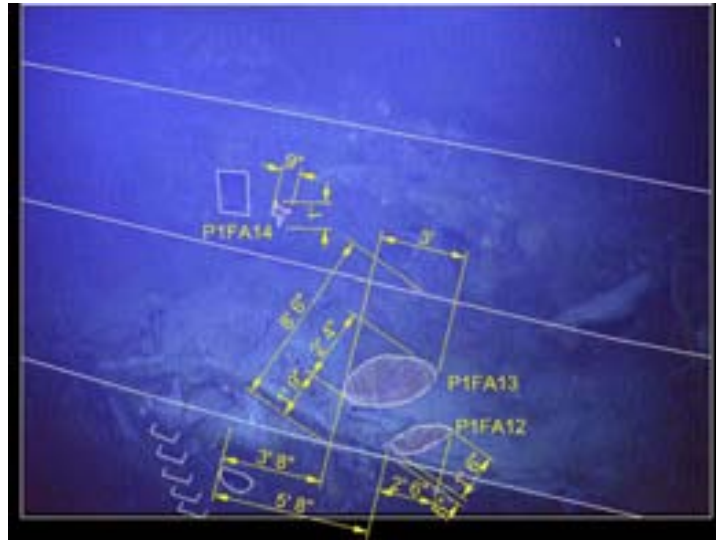

Figure 291: Damage to Forecastle deck. Into General Store and Victualling Store, upper deck [340].

#### P1FA13

Image : Screen capture from FSF Dive 1 File 52 (see Figure 291)  
 Location : Damage to Forecastle deck. Into upper deck, Prov. Issue Room and Victualling Office (see Figure 126)  
 Side : Port  
 Probable Cause : Fragment Damage/Fire Damage  
 Probable Weapon : Unknown

See P1FA12, except the hole is 3' x 2' 4" (900 x 700 mm).

#### P1FA14

Image : Screen capture from FSF Dive 1 File 52 (see Figure 291)  
 Location : Forecastle deck, Recreation Space (see Figure 126)  
 Side : Port  
 Probable Cause : Weapon Damage  
 Probable Weapon : Unknown

This is a 9" x 1' (230 x 300 mm) hole which is located on the Forecastle deck. The cause of this damage is not apparent. It is difficult to determine the extent of this damage due to the debris surrounding the hole and the lack of good video footage.

#### P03FA16

Image : FSF.002.0112 (see Figure 292)  
 Location : Upper Bridge, Director Control Tower (DCT) Support (see Figure 126)  
 Side : Port  
 Probable Cause : Contact detonation of shell  
 Probable Weapon : 15 cm HE Shell

DSTO-GD-0559

The most notable feature in Figure 292 is that the DCT is missing from the support. There is also extensive damage to the DCT support, with P03FA16 likely to be due to the contact detonation of a 15 cm HE Shell on the port side. This detonation would have generated a lot of fragments inside the DCT support, and would have also sprayed fragments around the upper bridge area. It is likely that this hit would have permanently disabled the DCT, but the detonation is unlikely to have been responsible for dislodging the DCT from the support. It is likely that the DCT was dislodged as part of the sinking process.

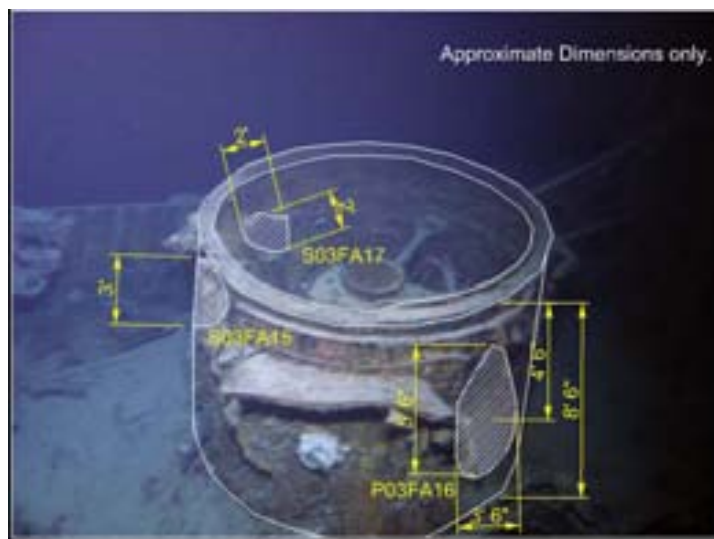

Figure 292: Director Control Tower Support, upper deck [345]

### P03FA18

Image : FSF.002.0318 (see Figure 293), FSF.002.0206 (see Figure 294)  
 Location : Upper Bridge, High Angle Calculating Station (HACS) support (see Figure 130)  
 Side : Hit from port side  
 Probable Cause : Shell penetration/detonation  
 Probable Weapon : 15 cm HE Shell

This damage is likely due to a shell hit and subsequent detonation to the HACS support. The base of this support is shown in Figure 293 and this figure shows that the metal on the back edge of the hole has buckled backwards. This suggests that the tower has fallen backwards on to the aft end of the upper superstructure. This is supported by damage to the deck in this region. It is not obvious from Figure 293 that the damage to the tower support is due to a shell hit, but the damage to the upper section of the tower support shown in Figure 294 leaves no doubt that the damage is due to a 15 cm HE Shell detonation with obvious fragment damage and metal petalling due to the detonation. This detonation would have caused the HACS tower to collapse. A reconstruction of the HACS position is provided in Figure 213 showing that a large amount of the HACS structure has been removed by this hit.

DSTO-GD-0559

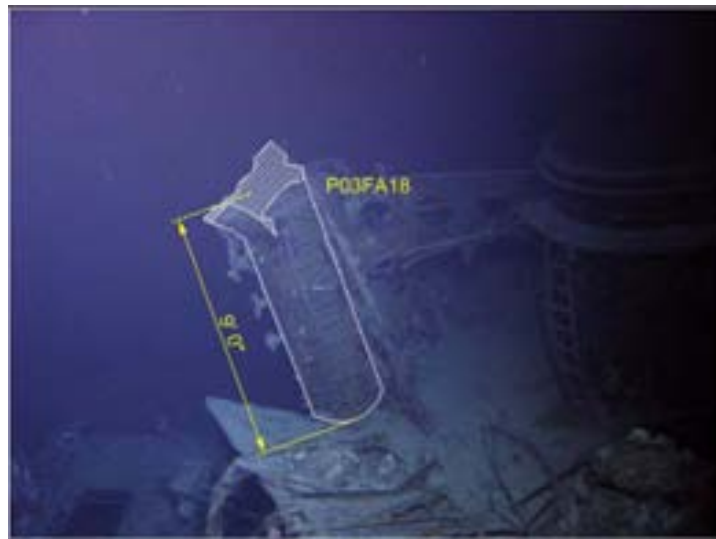

Figure 293: High Angle Control Tower support, upper deck [273]



Figure 294: Upper section of High Angle Control Tower in debris field [346]

**P2FA19**

Image : FSF.002.0124 (see Figure 295)  
 Location : Upper deck, Central Store Office (see Figure 126)  
 Side : Port  
 Probable Cause : Contact Detonation  
 Probable Weapon : 15 cm HE Shell  
 Hull Thickness : 35 lbs (22.2 mm)

This damage and that associated with P2FA20 and P2FA21 is probably due to the contact explosion of one or more shells.

DSTO-GD-0559

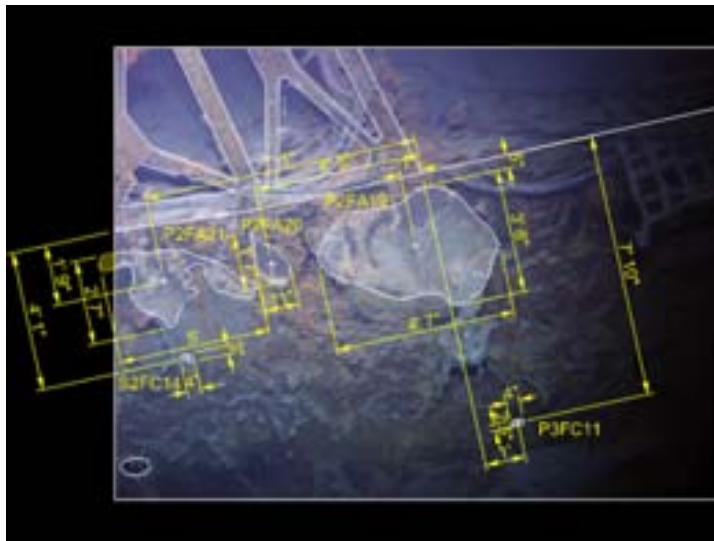

Figure 295: In vicinity of Diving Gear Store, upper deck [347]

#### P2FA20

Image : FSF.002.0124 (see Figure 295)  
 Location : Upper deck, Diving Gear Store (see Figure 126)  
 Side : Port  
 Probable Cause : Contact Detonation  
 Probable Weapon : 15 cm HE Shell  
 Hull Thickness : 35 lbs (22.2 mm)

See P2FA19.

#### P2FA21

Image : FSF.002.0124 (see Figure 295)  
 Location : Upper deck, Diving Gear Store (see Figure 126)  
 Side : Port  
 Probable Cause : Contact Detonation  
 Probable Weapon : 15 cm HE Shell  
 Hull Thickness : 35 lbs (22.2 mm)

See P2FA19.

#### P2FA26

Image : FSF.002.0135 (see Figure 296)  
 Location : Upper deck, in vicinity of Abandon Ship Store Lockers  
 (see Figure 126)  
 Side : Port  
 Probable Cause : Contact detonation  
 Probable Weapon : 15 cm HE Shell  
 Hull Thickness : 30 lbs (19.1 mm)

This damage is to the upper deck is in the vicinity of the Abandon Ship Store Lockers. The contents of the Abandon Ship Locker would have been damaged by this detonation. This detonation was also in the vicinity of the port side 36' Motor Pinnacle and Carley

DSTO-GD-0559

float, which would have also received fragment damage. This hit would also have severely damaged the 32' Cutter davit. Figure 220 is a reconstruction of the boats and davits in the vicinity of these hits.

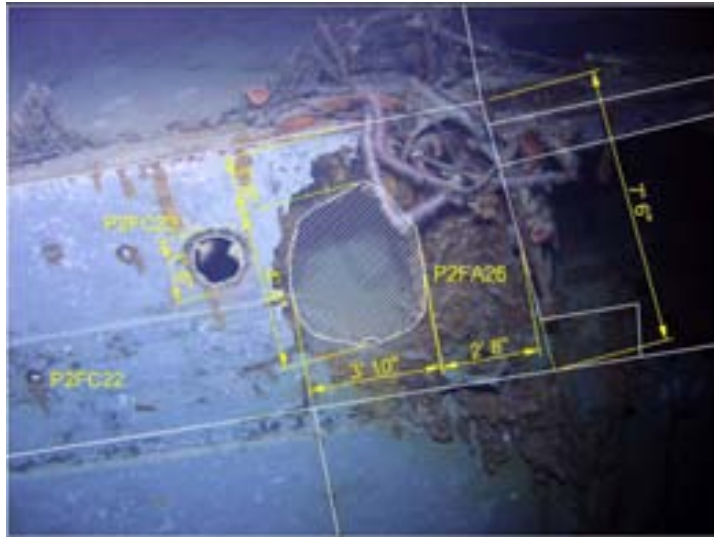

Figure 296: In vicinity of Abandon Ship Store Lockers, upper deck [249]

#### **P2FA28**

Image : FSF.002.0153 (see Figure 297)  
 Location : Upper deck, Bakery (see Figure 127)  
 Side : Port  
 Probable Cause : Contact detonation  
 Probable Weapon : 15 cm HE Shell

The bakery has received extensive damage from shells. P2FA28 is likely due to a contact detonation of a 15 cm HE Shell and has led to a 3' x 2' 6" (900 x 450 mm) hole on the port side. Note that there is extensive debris visible within the bakery, indicating extensive internal damage to this compartment. It is also likely that the aircraft and boats in this vicinity received fragment damage. The equipment originally in this area is shown in the reconstruction in Figure 216.

DSTO-GD-0559



Figure 297: Port side of Bakery, upper deck [292]

#### P2FA29

Image : FSF.002.0153 (see Figure 297)  
 Location : Upper deck, Bakery (see Figure 127)  
 Side : Port  
 Probable Cause : Contact detonation  
 Probable Weapon : 15 cm HE Shell

See P2FA28.

#### P2FA30

Image : FSF.002.0153 (see Figure 297)  
 Location : Upper deck, Bakery (see Figure 127)  
 Side : Port  
 Probable Cause : Contact detonation  
 Probable Weapon : 15 cm HE Shell

See P2FA28.

#### P3FA31

Image : FSF.001.0044 (see Figure 298)  
 Location : Lower deck, Engineers Fitting Shop (see Figure 127)  
 Side : Port  
 Probable Cause : Shell penetration or damage due to sinking  
 Probable Weapon : Uncertain

The cause of this damage is unclear, but is possibly due to a shell penetration.



DSTO-GD-0559

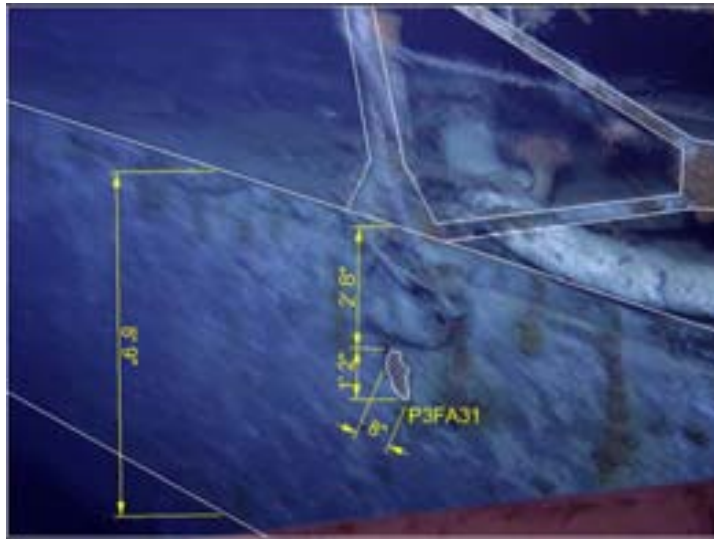

Figure 298: In vicinity of Engineers Fitting Shop, Lower deck [348]

### P2FA32

Image : FSF.004.0078 (see Figure 299)  
 Location : Upper deck, Catapult structure (see Figure 127)  
 Side : Port  
 Probable Cause : Shell detonation  
 Probable Weapon : 15 cm HE Shell

The catapult on *Sydney* was able to be rotated to launch the aircraft. It is not clear which direction the catapult was facing when it was hit, but for this analysis it will be assumed to have been in the stowed position. This hit to the catapult would have thrown a lot of fragments over the open decks around the catapult, including the boat. Hot fragments from shell hits to the catapult may have caused the Walrus aircraft to catch fire. Figure 216 shows the equipment surrounding the catapult, and it is easy to see how these hits would have sprayed hot fragments onto the aircraft.

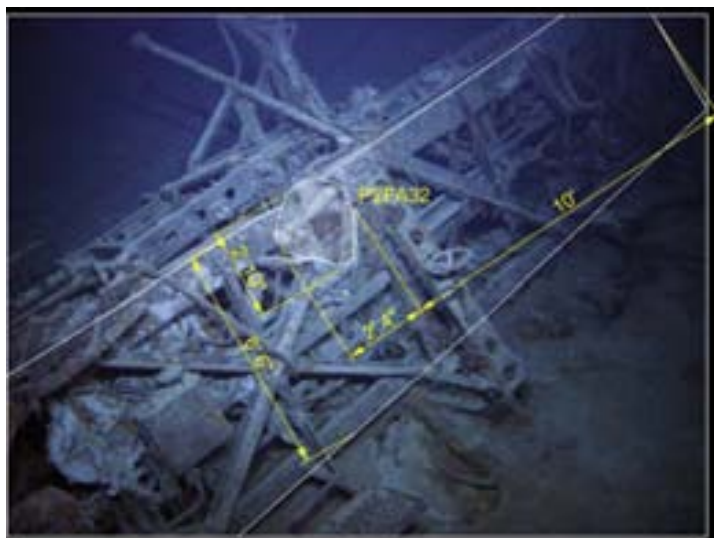

Figure 299: Damage to Catapult [349]

DSTO-GD-0559

**P2FA33**

Image : FSF.004.0079 (see Figure 300)  
 Location : Upper deck, Catapult structure (see Figure 127)  
 Side : Port  
 Probable Cause : Shell detonation  
 Probable Weapon : 15 cm HE Shell

As per P2FA32.

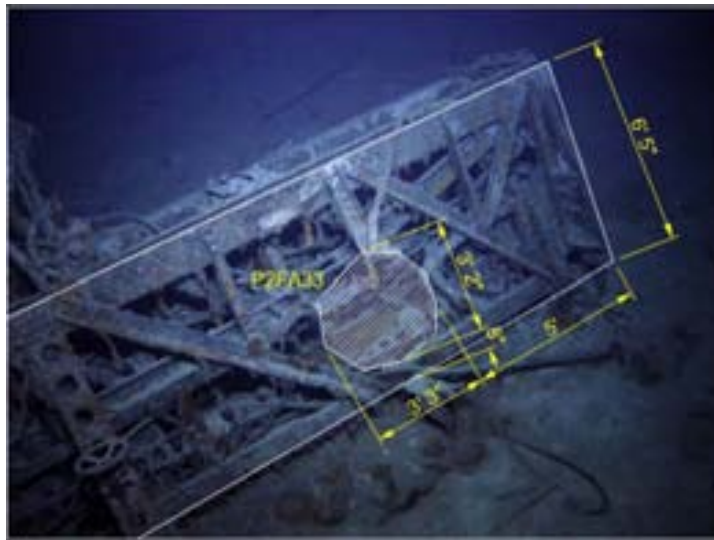

Figure 300: Damage to Catapult [350]

#### A.1.5 Port side damage – Class B Damage

**P01PB03**

Image : FSF.001.0077 (see Figure 301)  
 Location : Front of B Turret (see Figure 125)  
 Side : Port  
 Probable Cause : Partial shell penetration  
 Probable Weapon : 15 cm HE Shell  
 Armour Thickness: 1" (25 mm)

The hole size indicates that the shell failed to fully penetrate the armour plating. The shell may have possibly fallen to the deck and exploded causing the damage at P1FA05. This hit has also likely caused the roof of B Turret to be removed (see red hashing in Figure 301). Figure 302 indicates that internals of B turret are largely intact suggesting that there has not been an internal detonation inside B Turret, though the impact which created this hole would have resulted in metal fragments from the armour plating entering the turret at high speed.

DSTO-GD-0559

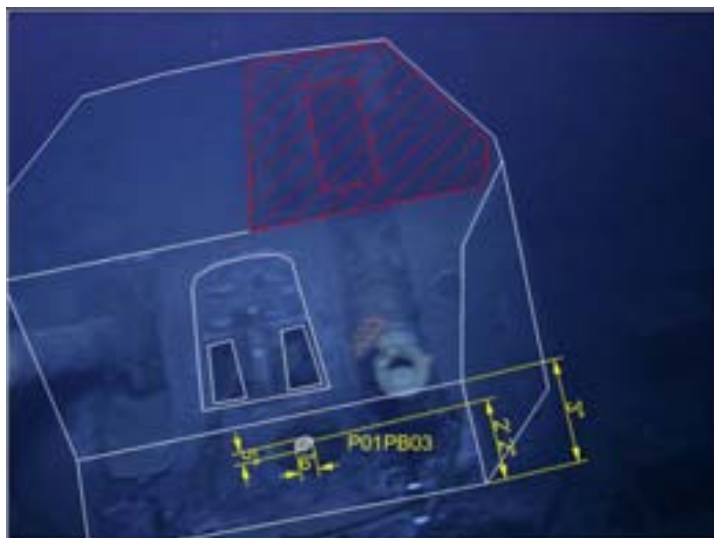

Figure 301: Front of B Turret [351]



Figure 302: Internals of B Turret are largely intact [352]

**P2FB04**

Image : Screen capture from FSF Dive 2 File 101 (see Figure 303)  
 Location : Upper deck, Musician's Mess (see Figure 125)  
 Side : Port  
 Probable Cause : Shell Penetration  
 Probable Weapon : 15 cm HE Shell  
 Hull Thickness : 25 lbs (15.9 mm)

This hole is likely due to a 15 cm HE Shell penetrating the Upper deck hull into the Musician's Mess. This shell would have detonated inside this mess area causing considerable internal damage if the shell detonated.

DSTO-GD-0559

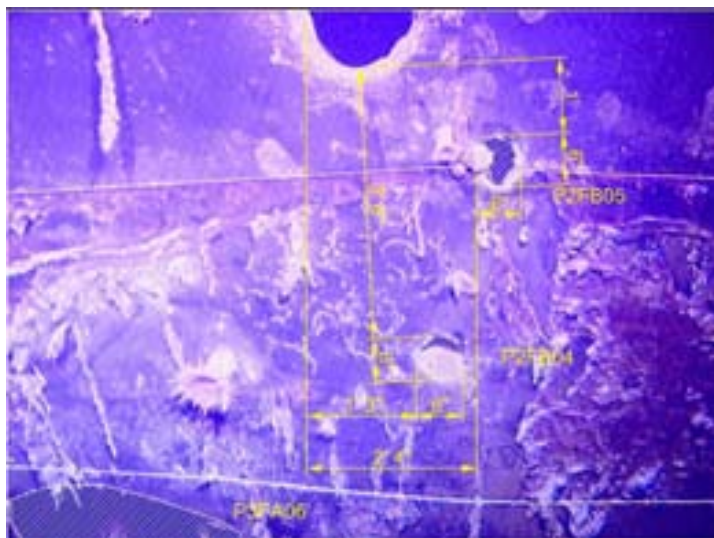

Figure 303: In vicinity of Musician's Mess, upper deck [343]

#### **P2FB05**

Image : Screen capture from FSF Dive 2 File 101 (see Figure 303)  
 Location : Upper deck, Musician's Mess (see Figure 125)  
 Side : Port  
 Probable Cause : Shell Penetration  
 Probable Weapon : 15 cm HE Shell  
 Hull Thickness : 25 lbs (15.9 mm)

This hole is likely due to a 15 cm HE Shell penetrating the upper deck hull into the Musician's Mess. Again, there would have been considerable internal damage.

#### **P3FB08**

Image : FSF.002.0214 (see Figure 304)  
 Location : Lower deck, No. 4 Lower Mess (see Figure 126)  
 Side : Port  
 Probable Cause : Shell Penetration  
 Probable Weapon : 15 cm HE Shell  
 Hull Thickness : 30 lbs (19.1 mm)

This is a clean penetration into the No. 4 Lower Mess area on Lower deck and is likely due to a 15 cm HE Shell. This shell would have detonated inside the No.4 Lower Mess. There are multiple clean penetrations in to the No. 4 Lower Mess area, and significant internal damage would be expected in this compartment.

DSTO-GD-0559

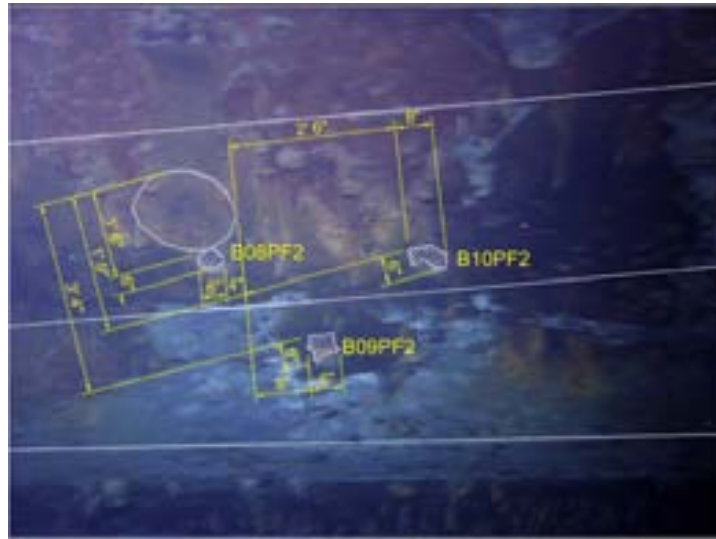

Figure 304: In vicinity of No. 4 Lower Mess, Lower deck [295]

#### P3FB09

Image : FSF.002.0214 (see Figure 304)  
 Location : Lower deck, No. 4 Lower Mess (see Figure 126)  
 Side : Port  
 Probable Cause : Fragments from internal detonation  
 Probable Weapon : 15 cm HE Shell  
 Hull Thickness : 30 lbs (19.1 mm)

See P3FB08.

#### P3FB10

Image : FSF.002.0214 (see Figure 304)  
 Location : Lower deck, No. 4 Lower Mess (see Figure 126)  
 Side : Port  
 Probable Cause : Fragments from internal detonation  
 Probable Weapon : 15 cm HE Shell  
 Hull Thickness : 30 lbs (19.1 mm)

See P3FB08.

#### P3FB12

Image : FSF.002.0213 (see Figure 305)  
 Location : Lower deck, No. 4 Lower Mess (see Figure 126)  
 Side : Port  
 Probable Cause : Shell penetration  
 Probable Weapon : 15 cm HE Shell  
 Hull Thickness : 30 lbs (19.1 mm)

See P3FB08.

DSTO-GD-0559

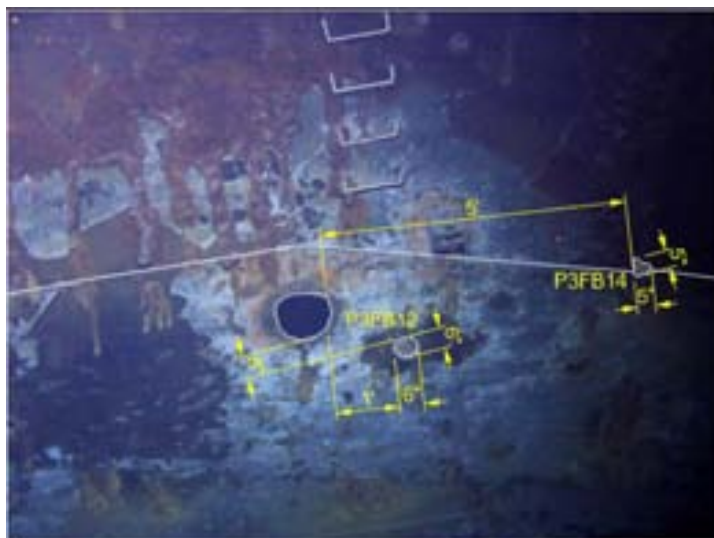

Figure 305: In vicinity of No. 4 Lower Mess, Lower deck [353]

#### **P3FB14**

Image : FSF.002.0213 (see Figure 305)  
 Location : Lower deck, No. 4 Lower Mess (see Figure 126)  
 Side : Port  
 Probable Cause : Shell Penetration  
 Probable Weapon : 15 cm HE Shell  
 Hull Thickness : 30 lbs (19.1 mm)

See P3FB08.

#### **P02FB16**

Image : Screen capture from FSF Dive 1 File 52 (see Figure 306)  
 Location : Lower Bridge, Lobby Area (see Figure 126)  
 Side : Port  
 Probable Cause : Shell penetration  
 Probable Weapon : 15 cm HE Shell

This is a clean penetration into the port side of the bridge. This hit probably detonated inside the bridge causing considerable damage.

DSTO-GD-0559

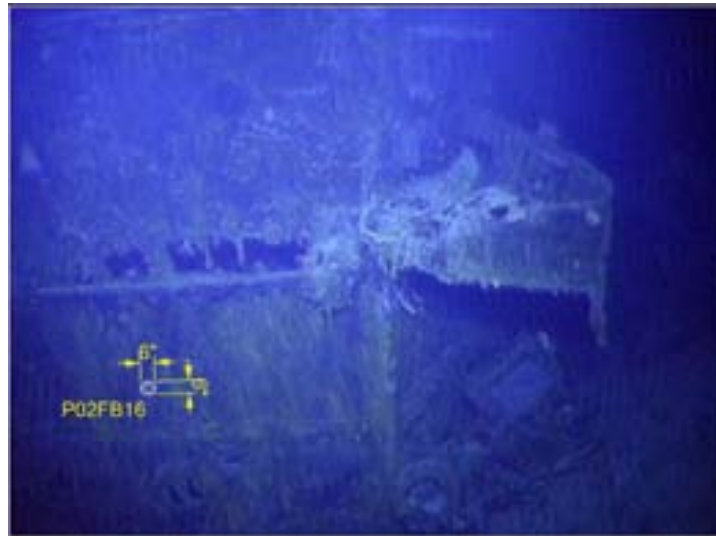

Figure 306: Port side of Bridge [340]

**P03FB18**

Image : FSF.006.0012 (see Figure 307)  
 Location : Upper Bridge, DCT (see Figure 130)  
 Side : Port  
 Probable Cause : Shell Penetration  
 Probable Weapon : 15 cm HE Shell

This hit to the DCT is on the port side of the DCT. The DCT was probably facing to port when hit, so the hit was caused by a shell fired at the starboard side of *Sydney*. This shell hit appears to have detonated internally, and would have caused considerable damage inside the DCT.

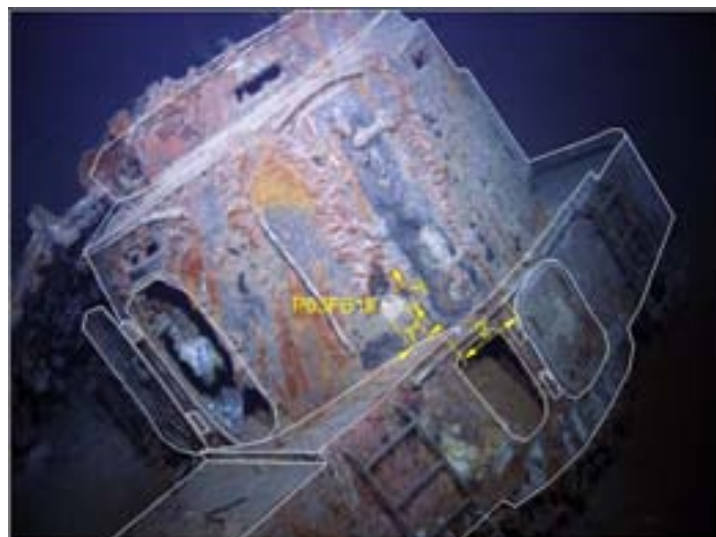

Figure 307: Director Control Tower [354]

DSTO-GD-0559

**P3FB19**

Image : FSF.002.0212 (see Figure 308)  
 Location : Lower deck, Stoker's Mess (see Figure 126)  
 Side : Port  
 Probable Cause : Shell Penetration  
 Probable Weapon : 15 cm Shell  
 Hull Thickness : 30lbs (19.1 mm)

This hole is probably due to 15 cm cleanly penetrating the hull. This shell would have entered the Stoker's Mess on Lower deck and detonated internally. There are multiple hits to the Stoker's Mess and it is likely that this compartment received extensive internal damage.

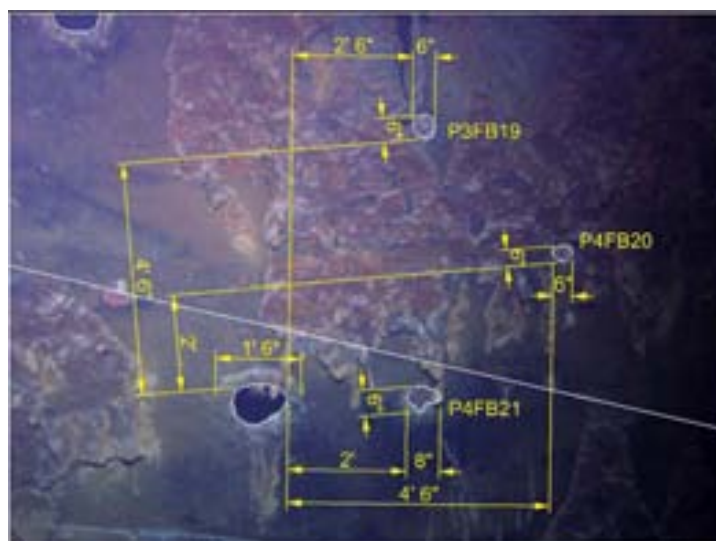

Figure 308: In vicinity of Stoker's Mess Lower deck [355]

**P4FB20**

Image : FSF.002.0212 (see Figure 308)  
 Location : Platform deck, Medical Store (see Figure 126)  
 Side : Port  
 Probable Cause : Shell Penetration  
 Probable Weapon : 15 cm HE Shell  
 Hull Thickness : 30 lbs (19.1 mm)

This hole is probably due to 15 cm cleanly penetrating the hull. This shell would have entered the Medical Store on Platform deck and detonated internally.

**P4FB21**

Image : FSF.002.0212 (see Figure 308)  
 Location : Platform deck, Medical Store (see Figure 126)  
 Side : Port  
 Probable Cause : Shell Penetration  
 Probable Weapon : 15 cm HE Shell  
 Hull Thickness : 30 lbs (19.1 mm)  
 See P4FB20.



DSTO-GD-0559

**P3FB22**

Image : FSF.002.0128 (see Figure 309)  
 Location : Lower deck, Stoker's Mess (see Figure 126)  
 Side : Port  
 Probable Cause : Shell Penetration  
 Probable Weapon : 15 cm HE Shell  
 Hull Thickness : 30 lbs (19.1 mm)

See P3FB19.

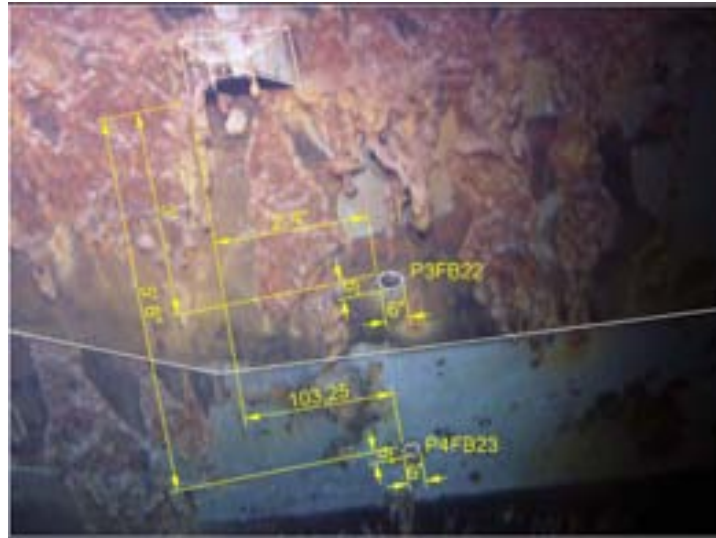

Figure 309: In vicinity of Stoker's Mess, Lower deck [356]

**P4FB23**

Image : FSF.002.0128 (see Figure 309)  
 Location : Platform deck, Switchboard Room (see Figure 126)  
 Side : Port  
 Probable Cause : Shell Penetration  
 Probable Weapon : 15 cm HE Shell  
 Hull Thickness : 30 lbs (19.1 mm)

This hole is likely to be due to a shell cleanly penetrating the hull protecting the Switchboard room. This shell would have detonated internally causing damage to the Platform deck around the Switchboard room and Breaker rooms.

**P3FB27**

Image : FSF.002.0131 (see Figure 310)  
 Location : Lower deck, Stoker's Mess (see Figure 126)  
 Side : Port  
 Probable Cause : Shell penetration  
 Probable Weapon : 15 cm HE Shell  
 Hull Thickness : 30 lbs (19.1 mm)

See P3FB19.

DSTO-GD-0559

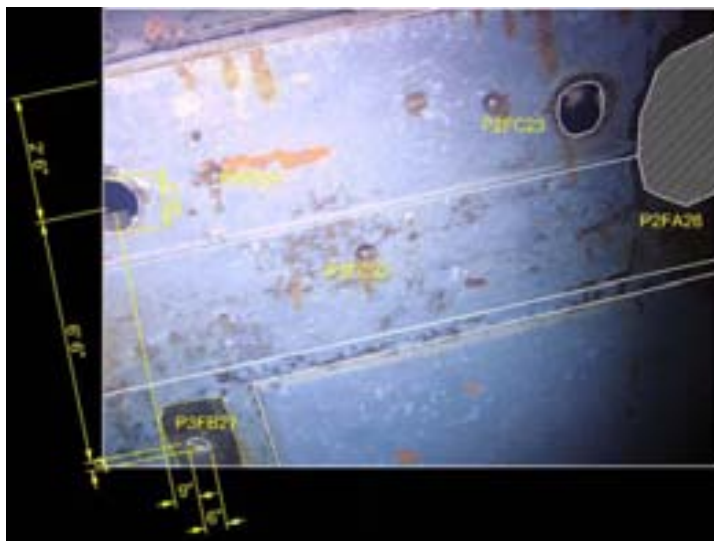

Figure 310: In vicinity of Stoker's Mess [357]

**P3PB35 (Correct number)**

Image : FSF.001.0053 (see Figure 311)  
 Location : Lower deck, Electric Light Room (see Figure 127)  
 Side : Port  
 Probable Cause : Partially penetrating contact detonation  
 Armour Thickness : 164 lbs (104.1 mm)

This hit has occurred on the seam edge of the armour plate and it appears that the detonation has occurred external. Partial penetration has occurred with limited damage to the internal compartment.

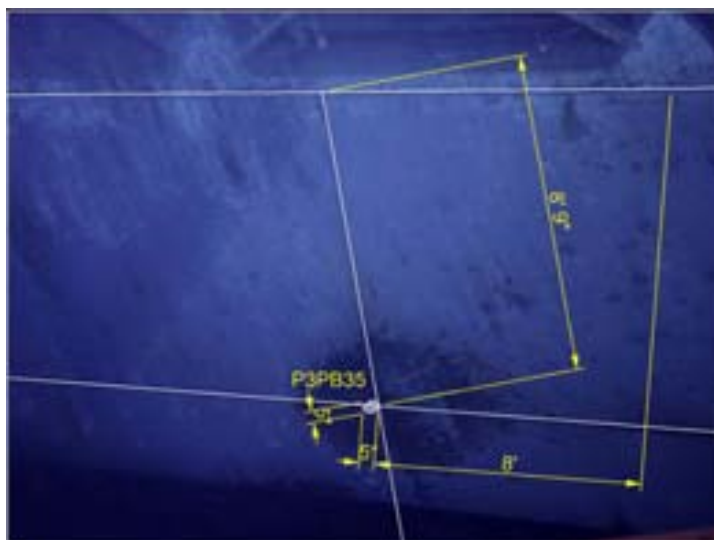

Figure 311: In vicinity of Electric Light room, Lower deck and below 31 ft whaler [358]

DSTO-GD-0559

**P2FB39**

Image : FSF.001.0046 (see Figure 312)  
 Location : Upper deck, Shipwright's Workshop, (see Figure 127)  
 Side : Port  
 Probable Cause : Shell penetration  
 Probable Weapon : 15 cm HE Shell

A shell has penetrated into the Shipwright's Workshop. Due to the location of this shell hit, it is also likely that the boat next to the Shipwright's Workshop has also been hit. Damage can be identified on this boat that aligns with this penetration.

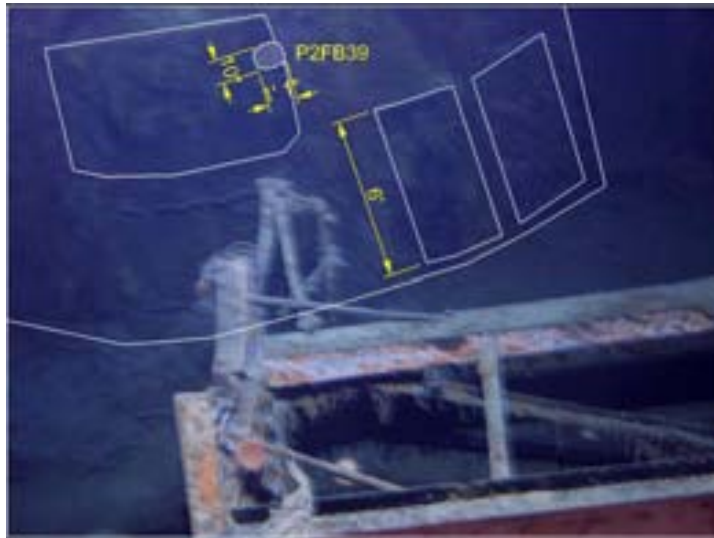

Figure 312: Shipwright's Workshop below Catapult. [208]

**P1FB50**

Image : FSF.002.0263 (see Figure 313)  
 Location : Aft of X Turret (see Figure 128)  
 Side : Port  
 Probable Cause : Shell Penetration  
 Probable Weapon : 15 cm HE Shell

This shell has cleanly penetrated X turret on the port side. It is not clear which direction X turret was facing when this damage occurred. This shell hit may have also been associated with damage at P1FA38. Assuming that the turret has not moved since being hit, it is likely that the shell that created this damage was fired at *Sydney's* starboard side.

DSTO-GD-0559



Figure 313: Hit into side of X Turret [359]

#### A.1.6 Port side damage – Class C Damage

##### **P3FC11**

Image : FSF.002.0124 (see Figure 295)  
 Location : Lower deck, Stoker's Mess (see Figure 126)  
 Side : Port  
 Probable Cause : Unknown  
 Probable Weapon : Unknown

The hole size possibly indicates a partial shell penetration or a very large fragment. It is difficult to take measurements or get a clear view of this damage from the available footage.

##### **P2FC14**

Image : FSF.002.0124 (see Figure 295)  
 Location : Upper deck, Central Store Office (see Figure 126)  
 Side : Port  
 Probable Cause : Unknown  
 Probable Weapon : Unknown

See P3FC11.

##### **P1FC16**

Image : FSF.002.0137 (see Figure 314)  
 Location : Forecastle deck, Smith's Shop (see Figure 126)  
 Side : Port  
 Probable Cause : Fragment damage due to external detonation  
 Probable Weapon : Likely to be a 15 cm HE Shell

There is significant fragment damage to the Smith's shop and the Secondary Wireless Transmission trunk. The origin of these fragments is unclear, but the hole size is

DSTO-GD-0559

consistent with a 15 cm HE Shell. What ever has generated these fragments would also have likely damaged the 32' Cutter that was stowed in the vicinity. Due to the number of penetrations in Figure 126, not all of the holes have been highlighted.

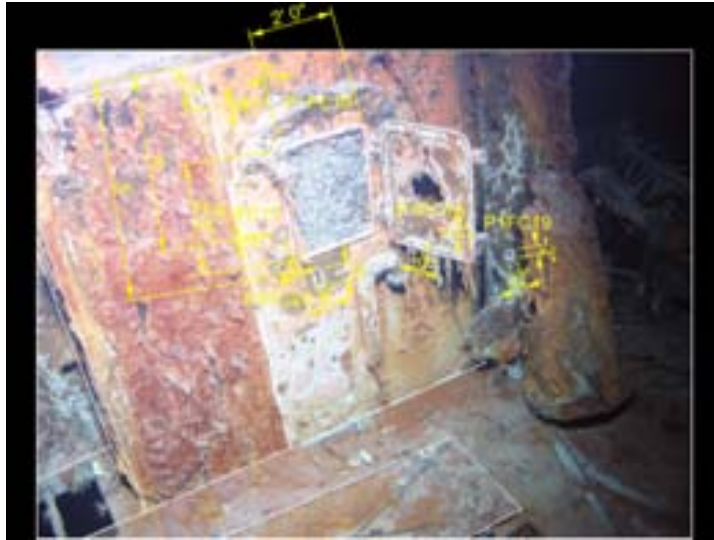

Figure 314: Port side of Smith's Shop [360]

#### **P1FC17**

Image : FSF.002.0137 (see Figure 314)  
 Location : Forecastle deck, Smith's Shop (see Figure 126)  
 Side : Port  
 Probable Cause : Fragment damage due to external detonation  
 Probable Weapon : Likely to be a 15 cm HE Shell

See P1FC16.

#### **P1FC18**

Image : FSF.002.0137 (see Figure 314)  
 Location : Forecastle deck, Smith's Shop (see Figure 126)  
 Side : Port  
 Probable Cause : Fragment damage due to external detonation  
 Probable Weapon : Likely to be a 15 cm HE Shell

See P1FC16.

#### **P1FC19**

Image : FSF.002.0137 (see Figure 314)  
 Location : Forecastle deck, Smith's Shop (see Figure 126)  
 Side : Port  
 Probable Cause : Fragment damage due to external detonation  
 Probable Weapon : 15 cm HE Shell

See P1FC16.

DSTO-GD-0559

**P1FC20**

Image : FSF.002.0137 (see Figure 314)  
 Location : Forecastle deck, Smith's Shop (see Figure 126)  
 Side : Port  
 Probable Cause : Fragment damage due to external detonation  
 Probable Weapon : 15 cm HE Shell

See P1FC16.

**P2FC21**

Image : FSF.002.0131 (see Figure 296)  
 Location : Upper deck, Abandon Ship Store Lockers (see Figure 127)  
 Side : Port  
 Probable Cause : Fragment damage due to external detonation/Shell Penetration  
 Probable Weapon : 15 cm HE Shell\3.7 cm Shell

This damage is either due to fragments from an external detonation or possibly from small arms fire.

**P2FC22**

Image : FSF.002.0131 (see Figure 310)  
 Location : Upper deck, Abandon Ship Store Lockers (see Figure 127)  
 Side : Port  
 Probable Cause : Fragment damage due to external detonation/Shell Penetration  
 Probable Weapon : 15 cm HE Shell\3.7 cm Shell

See P2FC21.

**P2FC23**

Image : FSF.002.0131 (see Figure 310)  
 Location : Upper deck, Abandon Ship Store Lockers (see Figure 127)  
 Side : Port  
 Probable Cause : Fragment damage due to external detonation/Shell Penetration  
 Probable Weapon : 15 cm HE Shell\3.7 cm Shell

See P2FC21.

**P2FC24**

Image : FSF.002.0153 (see Figure 297)  
 Location : Upper deck, Bakery (see Figure 127)  
 Side : Port  
 Probable Cause : Fragment damage due to internal detonation  
 Probable Weapon : 15 cm HE Shell

**P2FC25**

Image : FSF.002.0153 (see Figure 297)  
 Location : Upper deck, Bakery (see Figure 127)  
 Side : Port  
 Probable Cause : Fragment damage due to internal detonation  
 Probable Weapon : 15 cm HE Shell

DSTO-GD-0559

**P2FC26**

Image : FSF.002.0153 (see Figure 297)  
Location : Upper deck, Bakery (see Figure 127)  
Side : Port  
Probable Cause : Fragment damage due to internal detonation  
Probable Weapon : 15 cm HE Shell

**P2FC27**

Image : FSF.002.0153 (see Figure 297)  
Location : Upper deck, Bakery (see Figure 127)  
Side : Port  
Probable Cause : Fragment damage due to internal detonation  
Probable Weapon : 15 cm HE Shell

**P2FC28**

Image : FSF.002.0153 (see Figure 297)  
Location : Upper deck, Bakery (see Figure 127)  
Side : Port  
Probable Cause : Fragment damage due to internal detonation  
Probable Weapon : 15 cm HE Shell

**P2FC29**

Image : FSF.002.0153 (see Figure 297)  
Location : Upper deck, Bakery (see Figure 127)  
Side : Port  
Probable Cause : Fragment damage due to internal detonation  
Probable Weapon : 15 cm HE Shell

**P2FC30**

Image : FSF.002.0153 (see Figure 297)  
Location : Upper deck, Bakery (see Figure 127)  
Side : Port  
Probable Cause : Fragment damage due to internal detonation  
Probable Weapon : 15 cm HE Shell

**P2FC31**

Image : FSF.002.0153 (see Figure 297)  
Location : Upper deck, Bakery (see Figure 127)  
Side : Port  
Probable Cause : Fragment damage due to internal detonation  
Probable Weapon : 15 cm HE Shell

**P2FC32**

Image : FSF.002.0153 (see Figure 297)  
Location : Upper deck, Bakery (see Figure 127)  
Side : Port  
Probable Cause : Fragment damage due to internal detonation  
Probable Weapon : 15 cm HE Shell

DSTO-GD-0559

**P1FC36**

Image : FSF.002.0264 (see Figure 315)  
 Location : Rear of X Turret (see Figure 128)  
 Side : Port  
 Probable Cause : Fragment penetration from shell  
 Probable Weapon : 15 cm HE Shell

This damage is likely due to a shell entering X Turret at P1FB50 and detonating inside the turret. This detonation appears to have blown out the door. See P1FB50.

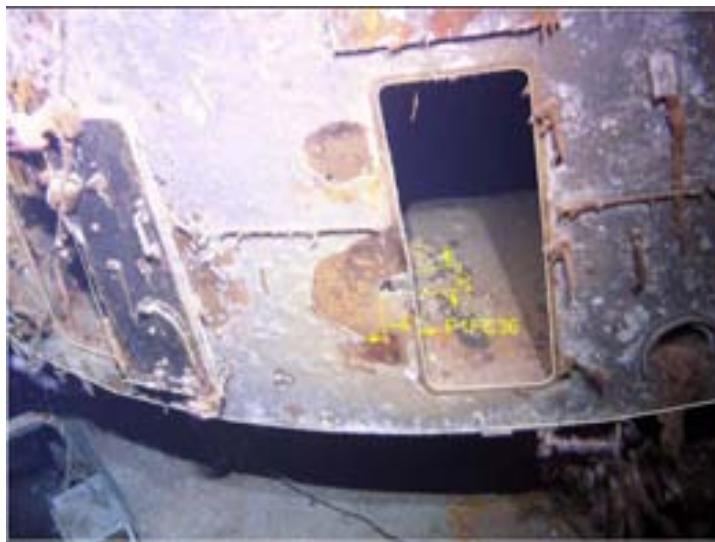

Figure 315: Aft of X Turret [304]

#### A.1.7 Starboard side damage – Class A Damage

**S1FA02**

Image : FSF.002.0033 (see Figure 316)  
 Location : Starboard armour plating of A Turret (see Figure 129)  
 Side : Starboard  
 Probable Cause : External shell contact detonation  
 Probable Weapon : 15 cm HE Shell  
 Armour Thickness: 1" (25 mm)

This is a 6' x 4' 4" (1800 x 1300 mm) size hole into the forward region of the starboard side of the A turret armour. This is likely to be caused by a 15 cm HE Shell from *Kormoran* exploding on contact with the turret armour. This section of armour has broken away from the remainder of A Turret and has fallen into the ship, this probably occurred as the ship was sinking. It is worth noting that this armour plating would weigh in the region of 3 tonnes. The number of hits to the armour indicates that it was still in place when damaged. Whilst the damage is on the starboard side of the turret, this only indicates that the starboard side of the turret was facing *Kormoran* when it was hit and that A turret was not facing *Kormoran* at the time. Given the position of the damage it is likely that the damage to this turret occurred sometime around when *Sydney* was travelling astern of *Kormoran*. It is likely that this damage alone would have



DSTO-GD-0559

destroyed the capability of this turret, let alone the three other hits that will subsequently be described.

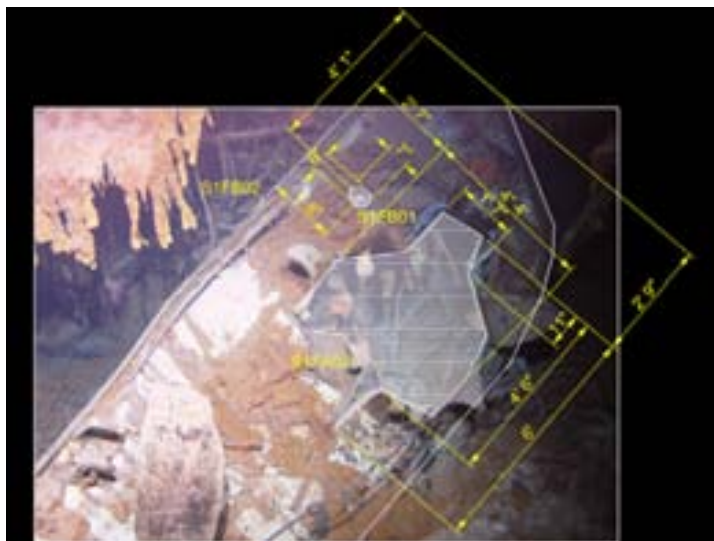

Figure 316: Forward section of starboard side of A turret [303]

#### S1FA03

Image : FSF.002.0034 (see Figure 317)  
 Location : Starboard armour plating of A Turret (see Figure 129)  
 Side : Starboard  
 Probable Cause : External shell contact detonation  
 Probable Weapon : 15 cm HE Shell  
 Armour Thickness : 1" (25 mm)

As per S1FA02, except a 5' 3" x 5' 2" (1600 x 1600 mm) hole.

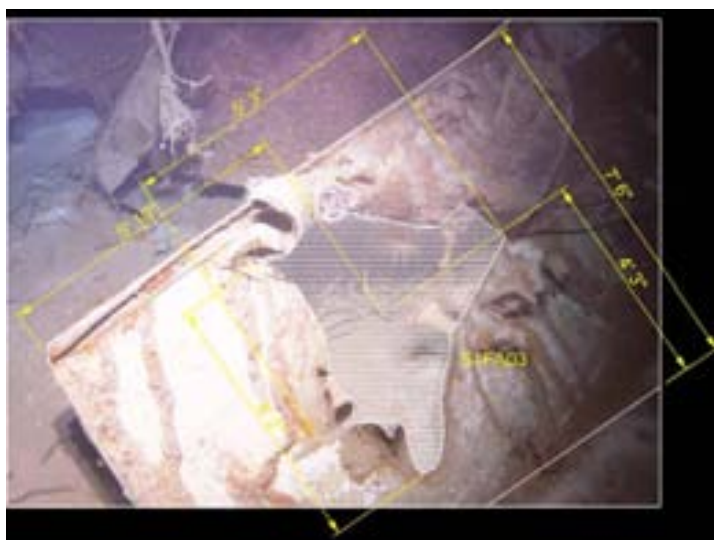

Figure 317: Aft section of starboard side of A turret [361]

DSTO-GD-0559

**S3FA07**

Image : FSF.002.0324 (see Figure 318)  
 Location : Lower deck, No. 3 Lower Mess and upper deck, Seaman's Mess  
 (see Figure 129)  
 Side : Starboard  
 Probable Cause : External shell contact detonation  
 Probable Weapon : 15 cm HE Shell  
 Hull Thickness : 25 lbs (15.9 mm)

This hole is likely caused by a contact detonation of a 15 cm HE Shell. This hole has opened up the starboard side of the ship between upper and Lower deck. The deck level is visible through this hole, and the hole has opened up the No. 3 Lower Mess and the Seaman's Mess on upper deck. A large number of fragments would have entered No. 3 Lower Mess area. This is a large hole with dimensions 4' 6" x 2' 9" (1400 x 850 mm).

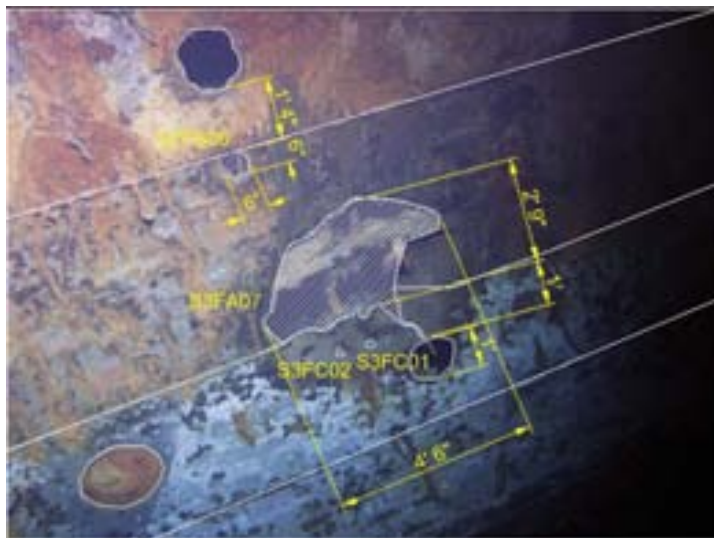

Figure 318: In vicinity of No. 3 Lower Mess, Lower deck and Seaman's Mess, upper deck [193]

**S03FA10**

Image : FSF.002.0314 (see Figure 319)  
 Location : Upper Bridge (see Figure 130)  
 Side : Starboard  
 Probable Cause : External Contact Detonation  
 Probable Weapon : 15 cm HE Shell

The shape of the missing material from the structure around the upper bridge is likely to have been caused by a contact detonation of a 15 cm HE Shell. It is difficult to tell the full extent of the damage in this region due to the extensive damage to the forward bridge superstructure, but the damage in this region is consistent with a shell hit. This shell hit would have extensively damaged the starboard rangefinder. Other damage in this region is associated with the break up of the upper superstructure on sinking. A reconstruction of the bridge is shown in Figure 320 to help understand where this damage is located.

DSTO-GD-0559

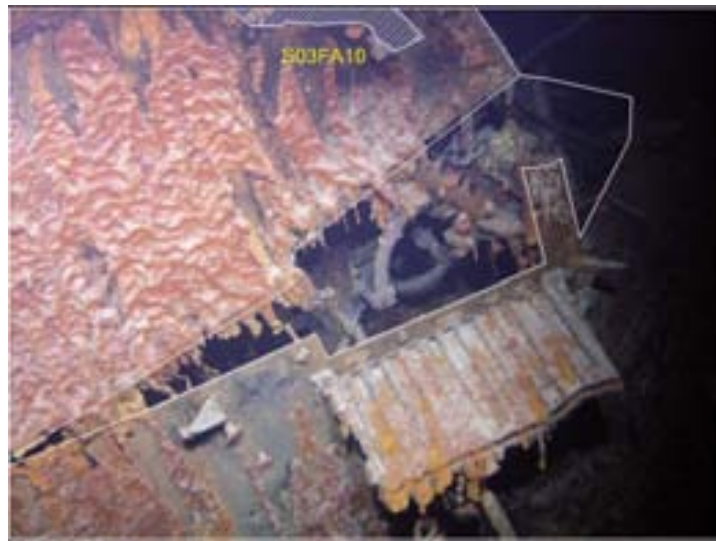

Figure 319: Starboard side of upper Bridge [362]



Figure 320: Reconstruction of Sydney Bridge

**S1FA11**

Image : Screen capture from FSF Dive 2 File 92 (see Figure 321)  
 Location : Damage to Forecastle deck. Into upper deck, Sick Bay (see Figure 130)  
 Side : Starboard  
 Probable Cause : Weapon Damage/Fire Damage  
 Probable Weapon : At least 15 cm HE Shell

There is a 5' 10" x 2' 2" (1800 x 660 mm) hole in the starboard Forecastle deck. It is difficult to tell the origins of this damage, but it is most likely to have been caused by a shell detonating on the deck. It is interesting to note that there is another hole in the port side deck (P1FA12) directly opposite this hole, and there may be some relationship

DSTO-GD-0559

between these damage locations. This hole has opened up the deck above the sick bay area on the upper deck.

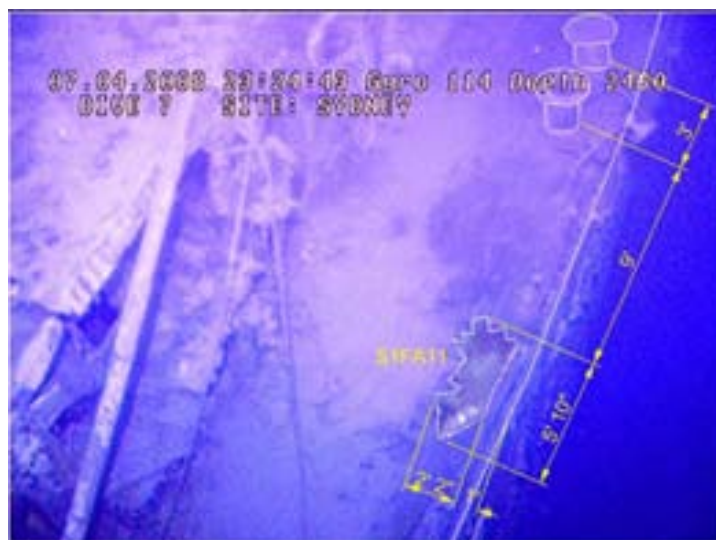

Figure 321: Damage to Forecastle deck. Into Sick Bay, upper deck [363]

#### S03FA15

Image : FSF.002.0112 (see Figure 292)  
 Location : Upper Bridge, Director Control Tower Support (see Figure 130)  
 Side : Starboard  
 Probable Cause : Internal or external detonation  
 Probable Weapon : 15 cm HE Shell

This hole is either due to an internal or external detonation. It is difficult to draw a conclusion on the direction of the weapon that has caused this damage. This damage may be associated with the damage at S03FA17. A reconstruction of the DCT is provided in Figure 211 to help visualise the configuration of the DCT prior to sinking.

#### S03FA17

Image : FSF.002.0112 (see Figure 292)  
 Location : Upper Bridge, Director Control Tower Support (see Figure 130)  
 Side : starboard  
 Probable Cause : Contact Detonation  
 Probable Weapon : 15 cm HE Shell

This hole is likely due to a 15 cm HE Shell penetrating the Director Control Tower support at an angle. It is possible that the shell responsible for this hole has also caused the hole S03FA15 through secondary damage.

#### S2FA22

Image : FSF.002.0309 (see Figure 322)  
 Location : Upper deck, Butchers Shop (see Figure 130)  
 Side : Starboard  
 Probable Cause : Shell penetration  
 Probable Weapon : 15 cm HE Shell

DSTO-GD-0559

This damage is probably due to a hit on the davit from a shell, which would have severely damaged the davit and made it impossible to launch any associated boats. This hit would have also damaged the Butcher's Shop. Figure 323 is a reconstruction of the boats and davits in the vicinity of these hits and the area shown in Figure 322 is highlighted in red.

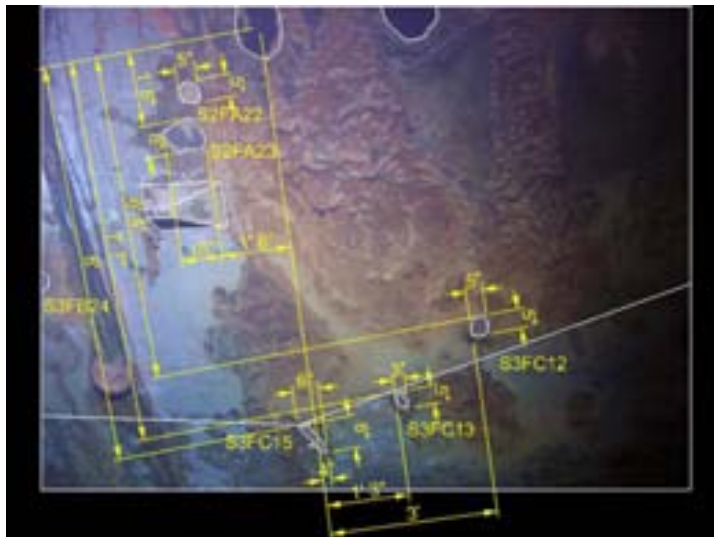

Figure 322: In vicinity of Butcher's Shop, upper deck [191]

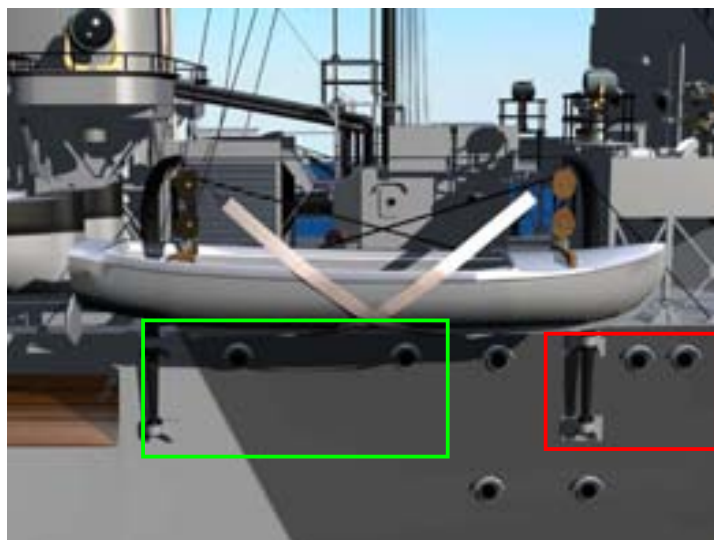

Figure 323: Reconstruction of equipment surrounding the boat launched via davits.

#### S2FA23

Image : FSF.002.0309 (see Figure 322)  
 Location : Upper deck, Butchers Shop (see Figure 130)  
 Side : Starboard  
 Probable Cause : Shell penetration

DSTO-GD-0559

Probable Weapon : 15 cm HE Shell

See S2FA22. This hole is difficult to see due to debris.

#### S1FA24

Image : FSF.003.0012 (see Figure 324)  
 Location : Forecastle deck, Smith's Shop (see Figure 130)  
 Side : Starboard  
 Probable Cause : Shell penetration  
 Probable Weapon : 15 cm HE Shell

This damage is likely to be caused by a shell penetrating the Smith's Shop at an angle. There is not enough information to determine the precise trajectory of this shell.

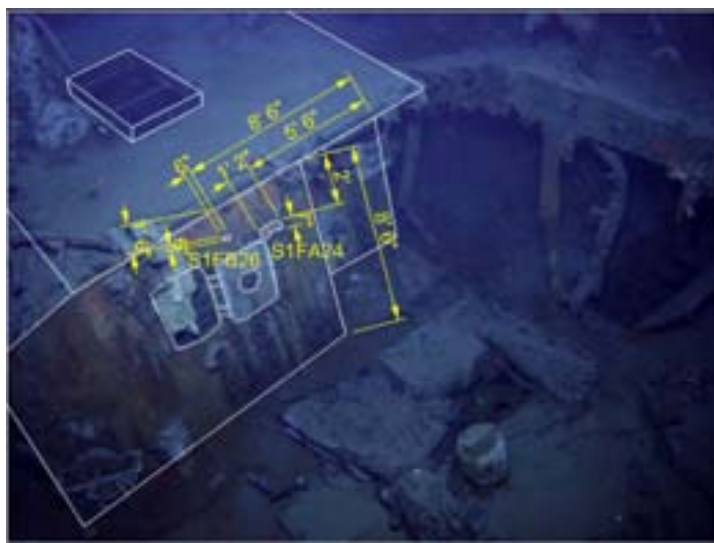

Figure 324: starboard side of Smith's Shop, Forecastle deck [201]

#### S2FA25

Image : FSF.002.0307 (see Figure 325)  
 Location : Upper deck, Covered Walkway (in vicinity of Disinfector)  
 (see Figure 130)  
 Side : Starboard  
 Probable Cause : Surface contact detonation  
 Probable Weapon : 15 cm HE Shell  
 Hull Thickness : 30 lbs (19.1 mm)

Probably a contact detonation and the hole is full of debris.

DSTO-GD-0559



Figure 325: Covered Walkway in vicinity of Disinfector, upper deck [364]

#### S2FA27

Image : FSF.003.0008 (see Figure 326)  
 Location : Upper deck, Enclosed Walkway (see Figure 130)  
 Side : Starboard  
 Probable Cause : Detonation on the davit  
 Probable Weapon : 15 cm HE Shell  
 Hull Thickness : 30 lbs (19.1 mm)

This damage is probably due to a shell hitting the davit and detonating causing this hole in the exterior bulkhead. This damage would also mean that the davits would not be able to be used to get the 32' boat off the ship. Figure 323 is a reconstruction of the boats and davits in the vicinity of these hits with the region shown in Figure 326 highlighted in green.



Figure 326: Enclosed walkway on upper deck [365]

#### S2FA34

Image : FSF.005.0234 (see Figure 327)

DSTO-GD-0559

Location : Upper deck, starboard side Torpedo Tubes (see Figure 132)  
 Side : Starboard  
 Probable Cause : Shell penetration  
 Probable Weapon : 15 cm HE Shell

This damage to the torpedoes is possibly due to a glancing shell hit. Note that this hit is on the bottom of the torpedo when stowed. The most damaged torpedo is stowed inboard of the torpedo had not been rotated ready to fire. It is possible that this torpedo was hit when the torpedo tubes were pointed outboard.

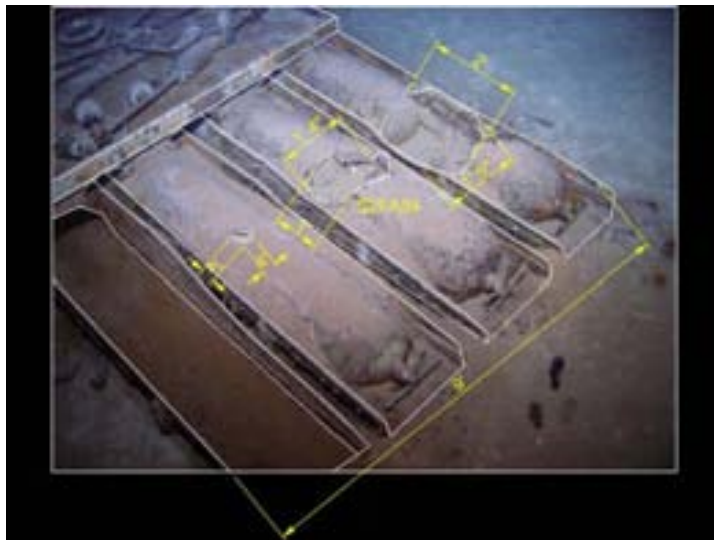

Figure 327: Starboard Torpedo Tubes [366]

### S2FA35

Image : Screen capture from FSF Dive 2 File 147 (see Figure 328)  
 Location : Upper deck, starboard Aft 4" Gun deck support (see Figure 132)  
 Side : Starboard  
 Probable Cause : Shell detonation  
 Probable Weapon : 15 cm HE Shell

This damage was likely to have been caused by a direct shell hit to this support.



DSTO-GD-0559

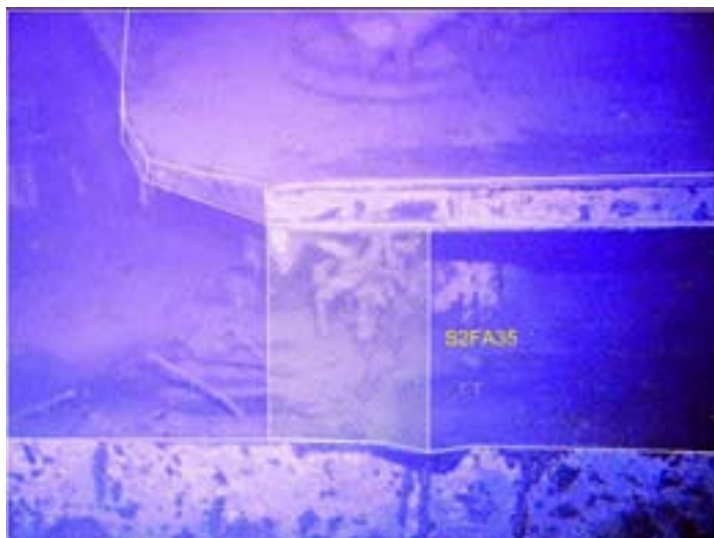

Figure 328: Starboard Side Aft 4" Gun deck Support missing [343]

### S2FA36

Image : FSF.003.0034 (see Figure 329)  
 Location : Lower deck, Cabin No. 5 or No. 7 (See Figure 132)  
 Side : Starboard  
 Probable Cause : Possibly contact detonation  
 Probable Weapon : Possibly 15 cm HE Shell  
 Hull Thickness : 35 lbs (22.2 mm)

This is a large hole in the side of the ship. It has likely been caused by the contact detonation of a 15 cm HE Shell. This hole is into Cabin No. 7 or No. 5 on the Lower deck.

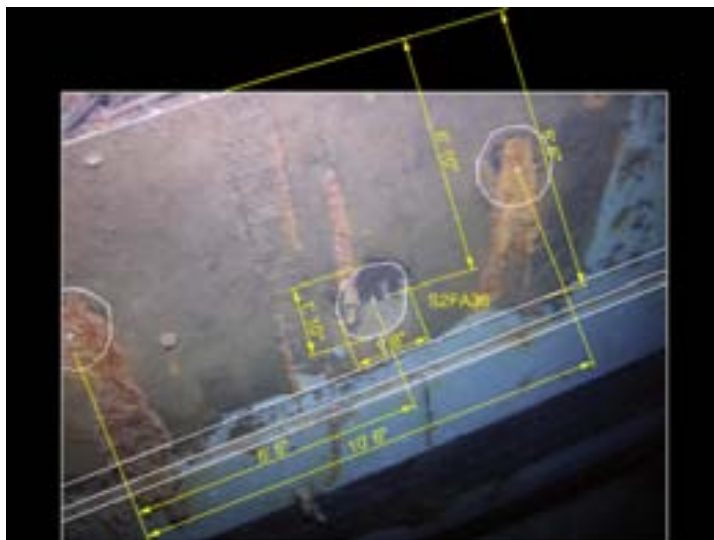

Figure 329: In vicinity of Cabins No. 5 and No. 7, Lower deck [218]

### S1FA37

Image : FSF.003.0032 (see Figure 330)

DSTO-GD-0559

Location : Into Forecastle deck, Captain's Day Dining Cabin(see Figure 132)  
 Probable Cause : Possibly contact detonation  
 Probable Weapon : Possibly 15 cm HE Shell

This is a 2' (600 mm) hole in the Forecastle deck. The surrounding debris makes it difficult to positively identify the cause of this hole.

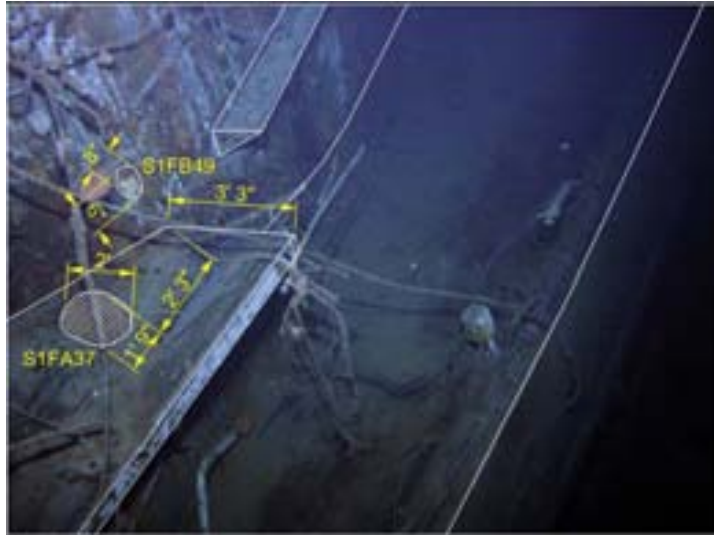

Figure 330: Starboard side of aft superstructure [219]

#### S2FA39

Image : FSF.002.0258 (see Figure 331)  
 Location : Upper deck, Captain's bath (see Figure 133)  
 Side : Starboard  
 Probable Cause : Fragments from internal detonation  
 Probable Weapon : 15 cm HE Shell

This damage is consistent with damage due to a shell detonation inside the Captains bath area. This damage is likely to be associated with the 15 cm HE Shell penetration at S2FB51.

DSTO-GD-0559

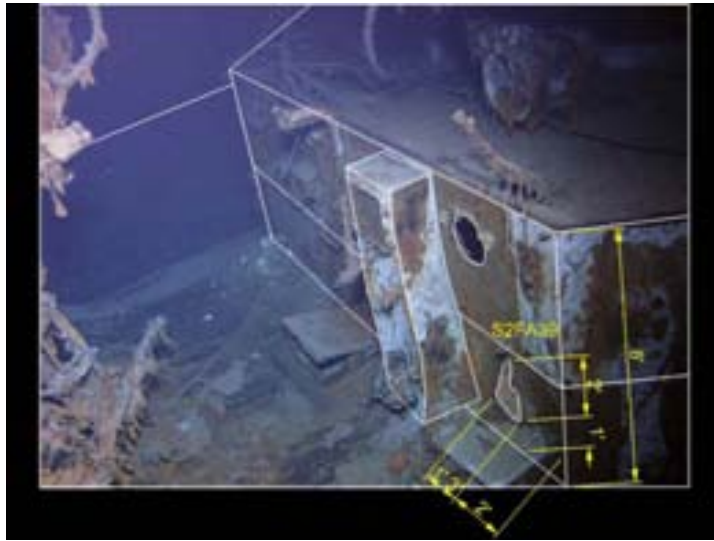

Figure 331: Superstructure forward of X turret [214]

#### S2FA40

Image : FSF.004.0031 (see Figure 332)  
 Location : Hinged container/possibly disinfectant on Lower deck  
 (see Figure 130)  
 Side : Starboard  
 Probable Cause : Shell penetration  
 Probable Weapon : 15 cm HE Shell

It has not been possible to positively identify this piece of debris, but it does have a clear penetration from a shell. This debris may be associated with the disinfectant and there are a number of shell penetrations into the hull in this region that would have allowed this damage to occur.



Figure 332: Shell penetration to what is possibly the Disinfectant [367]

A.1.8 Starboard side damage – Class B Damage

DSTO-GD-0559

**S1FB01**

Image : FSF.002.0029 (see Figure 333)  
 Location : Starboard side of A Turret (see Figure 129)  
 Side : Starboard  
 Probable Cause : Shell penetration  
 Probable Weapon : 15 cm HE Shell  
 Armour Thickness: 1" (25 mm)

This is a clean hole, suggesting that an AP shell has been used. This hole is into the starboard side of the A turret, indicating that the turret was not facing *Kormoran* when hit. The internal damage from the internal shell detonation of this shell would have put this turret out of action.

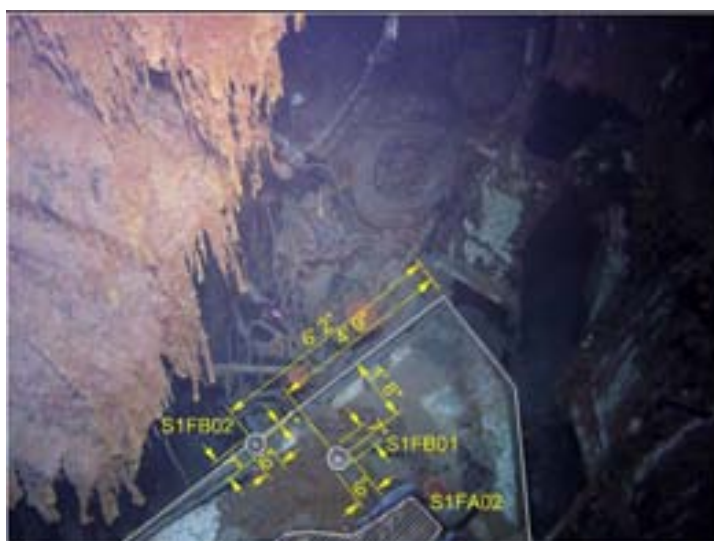

Figure 333: Starboard side of A Turret [368]

**S1FB02**

Image : FSF.002.0029 (see Figure 333)  
 Location : Starboard side of A Turret (see Figure 129)  
 Side : Starboard  
 Probable Cause : Shell penetration  
 Probable Weapon : 15 cm HE Shell  
 Armour Thickness: 1" (25 mm)

This shell has penetrated the armour plating of A turret. A marking on the floor of A Turret from this shell is visible in Figure 334. The internal damage to A Turret is extensive (when compared to the condition on B Turret) and it is certain that the damage to this turret put it completely out of action.

DSTO-GD-0559



Figure 334: Damage to side of A Turret marks from shell penetration are highlighted in red [369]

#### S2FB06

Image : FSF.002.0324 (see Figure 318)  
 Location : Upper deck, Seaman's Mess (see Figure 129)  
 Side : Starboard  
 Probable Cause : Shell penetration  
 Probable Weapon : 15 cm HE Shell  
 Hull Thickness : 25 lbs (15.9 mm)

This shell has penetrated the Upper deck hull and has entered the Seaman's Mess.

#### S4FB07

Image : FSF.002.0325 (see Figure 335)  
 Location : Platform deck, Refrigerating Machinery Compartment (see Figure 129)  
 Side : Starboard  
 Probable Cause : Shell penetration  
 Probable Weapon : 15 cm HE Shell  
 Hull Thickness : 20 lbs (12.7 mm)

This hole is close to the original waterline of the ship.

DSTO-GD-0559



Figure 335: In vicinity of Refrigerating Machinery Compartment, Platform deck [370]

#### S01FB11

Image : FSF.002.0214 (see Figure 336)  
 Location : Superstructure deck, Armament Office (see Figure 130)  
 Side : Starboard  
 Probable Cause : Shell penetration  
 Probable Weapon : 15 cm HE Shell

This appears to be a clean hole, possibly detonating inside the superstructure.



Figure 336: Starboard side of bridge superstructure [295]

DSTO-GD-0559

**S4FB13**

Image : Screen capture from FSF Dive 2 File 159 (see Figure 337)  
 Location : Platform deck, Cold Room (see Figure 130)  
 Side : Starboard  
 Probable Cause : Shell penetration  
 Probable Weapon : 15 cm HE Shell  
 Hull Thickness : 20lbs (12.7 mm)

This hit is likely to be due to a 15 cm HE Shell cleanly penetrating the hull and possibly detonating internal on the platform deck.

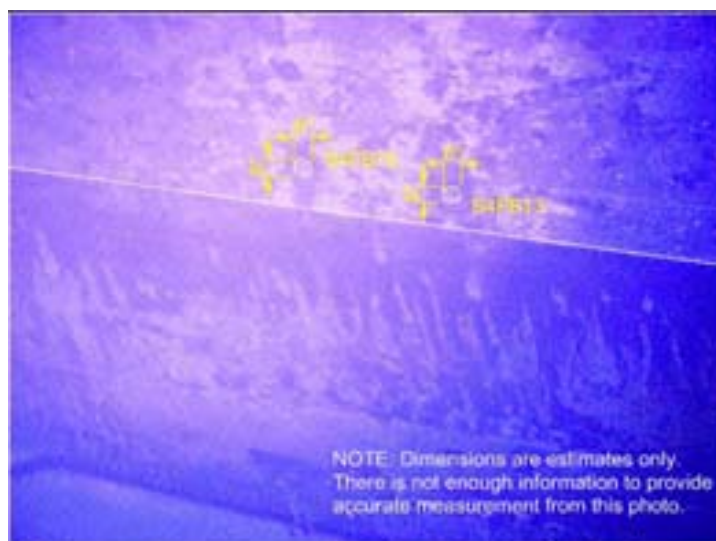

Figure 337: In vicinity of Cold Room, Platform deck [340]

**S4FB15**

Image : Screen capture from FSF Dive 2 File 159 (see Figure 337)  
 Location : Platform deck, Lobby Area (see Figure 130)  
 Side : Starboard  
 Probable Cause : Shell penetration  
 Probable Weapon : 15 cm HE Shell  
 Hull Thickness : 20lbs (12.7 mm)

See S4FB13.

**S2FB17**

Image : FSF.002.0311 (see Figure 338)  
 Location : Upper deck, Canteen (see Figure 130)  
 Side : Starboard  
 Probable Cause : Shell Penetration  
 Probable Weapon : 15 cm HE Shell  
 Hull Thickness : 35 lbs (22.2 mm)

This damage appears to be due to a 15 cm HE Shell cleanly penetrating and possibly detonating internally on the Upper deck.

DSTO-GD-0559



Figure 338: In vicinity of Canteen, Upper deck [192]

#### S3FB24

Image : FSF.002.0307 (see Figure 325)  
 Location : Lower deck, Stoker's Mess (see Figure 130)  
 Side : Starboard  
 Probable Cause : Shell penetration  
 Probable Weapon : 15 cm HE Shell

#### S2FB25

Image : FSF.002.0307 (see Figure 325)  
 Location : Upper deck, Butcher's Shop (see Figure 130)  
 Side : Starboard  
 Probable Cause : Shell penetration  
 Probable Weapon : 15 cm HE Shell  
 Hull Thickness : 35 lbs

#### S1FB26

Image : FSF.003.0012 (see Figure 324)  
 Location : Forecastle deck, Smith's Shop (see Figure 130)  
 Side : Starboard  
 Probable Cause : Shell penetration  
 Probable Weapon : 15 cm HE Shell

#### S3NB28

Image : FSF.003.0008 (see Figure 326)  
 Location : Lower deck, Kit Locker Flat (see Figure 130)  
 Side : Starboard  
 Probable Cause : Non-penetrating contact detonation  
 Probable Weapon : 15 cm HE Shell  
 Armour Thickness: 164 lbs (104.1 mm)



DSTO-GD-0559

This damage is on the armour plating and has failed to fully penetrate, but appears to have split the armour at a seam. Little or no damage would have occurred behind the armour plating.

**S3NB29**

Image : FSF.003.0008 (see Figure 326)  
 Location : Lower deck, Kit Locker Flat (see Figure 130)  
 Side : Starboard  
 Probable Cause : Non-penetrating shell contact detonation  
 Probable Weapon : 15 cm HE Shell  
 Armour Thickness: 164 lbs (104.1 mm)

This damage is on the armour plating and has failed to penetrate. Little or no damage would have occurred behind the armour plating.

**S4NB30**

Image : FSF.002.0306 (see Figure 339)  
 Location : Lower deck, Kit Locker Flat (see Figure 131)  
 Side : Starboard  
 Probable Cause : Non-penetrating contact detonation  
 Probable Weapon : 15 cm HE Shell  
 Armour Thickness: 164 lbs (104.1 mm)

This damage is on the armour plating and has failed to penetrate. No damage would have occurred behind the armour plating.

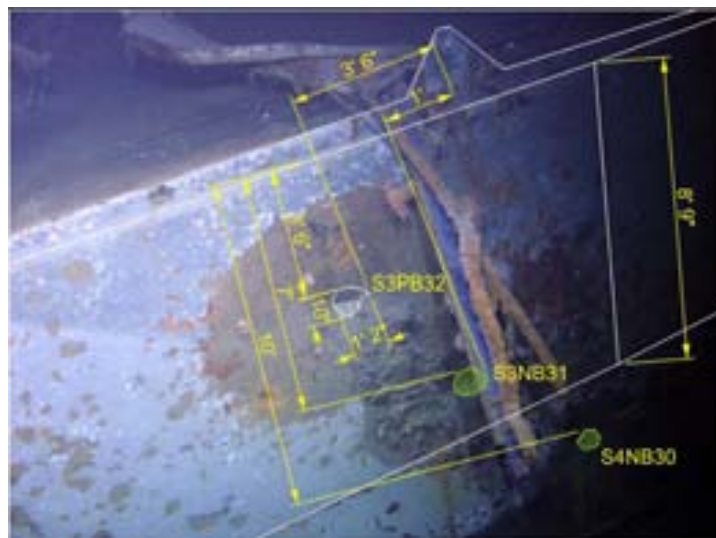

Figure 339: In vicinity of Kit Locker Flat, Lower deck [371]

**S3NB31**

Image : FSF.002.0306 (see Figure 339)  
 Location : Lower deck, Kit Locker Flat (see Figure 131)  
 Side : Starboard  
 Probable Cause : Non-penetrating contact detonation  
 Probable Weapon : 15 cm HE Shell

DSTO-GD-0559

Armour Thickness: 164 lbs (104.1 mm)

This damage is on the armour plating and has failed to penetrate. No damage would have occurred behind the armour plating.

### S3PB32

Image : FSF.002.0306 (see Figure 339)  
 Location : Lower deck, Kit Locker Flat (see Figure 131)  
 Side : Starboard  
 Probable Cause : Contact detonation  
 Probable Weapon : 15 cm HE Shell  
 Armour Thickness: 164 lbs (104.1 mm)

The shell has detonated on the surface of the armour causing a hole in the armour. This would have resulted in a number of fragments entering this compartment and a large number of fragments spraying into the water next to *Sydney*.

### S3NB33

Image : FSF.002.0304 (see Figure 340)  
 Location : Lower deck, Kit Locker Flat (see Figure 131)  
 Side : Starboard  
 Probable Cause : Non-penetrating contact detonation  
 Probable Weapon : 15 cm HE Shell  
 Armour Thickness: 164 lbs (104.1 mm)

This was a non-penetrating detonation. The fragment pattern suggests that this hit came in from an angle, but it is difficult to determine what the angle was.

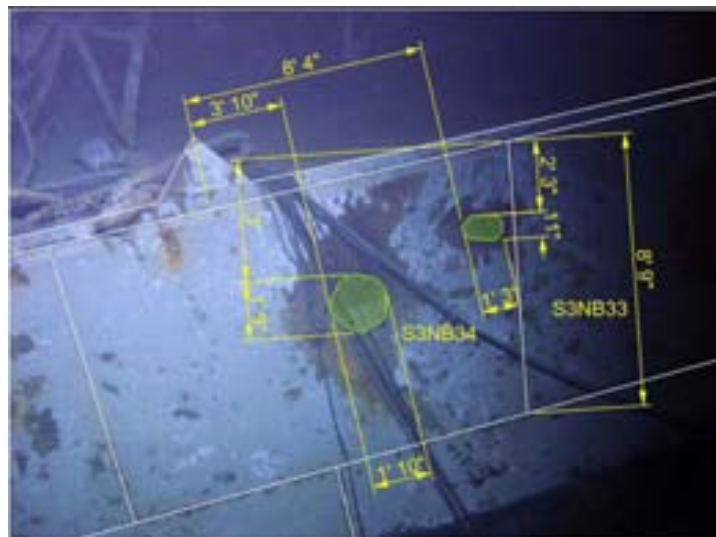

Figure 340: In vicinity of Kit Locker Flat, Lower deck [372]

### S3NB34

Image : FSF.002.0304 (see Figure 340)  
 Location : Lower deck, Kit Locker Flat (see Figure 131)  
 Side : Starboard

DSTO-GD-0559

Probable Cause : Non-penetrating contact detonation  
 Probable Weapon : 15 cm HE Shell  
 Armour Thickness: 164 lbs (104.1 mm)

This was a non-penetrating detonation. The fragment pattern suggests that this hit came in from an angle, but it is difficult to determine what the angle was. This detonation would have also sprayed a large number of fragments into the water.

**S3NB36**

Image : FSF.002.0301 (see Figure 341)  
 Location : OA's Workshop, Lower deck (see Figure 131)  
 Side : Starboard  
 Probable Cause : Non-penetrating contact detonation  
 Probable Weapon : 15 cm HE Shell  
 Armour Thickness: 164 lbs (104.1 mm)

This hit is a non-penetrating contact detonation and would not have caused damage to the compartments behind the armour plating.

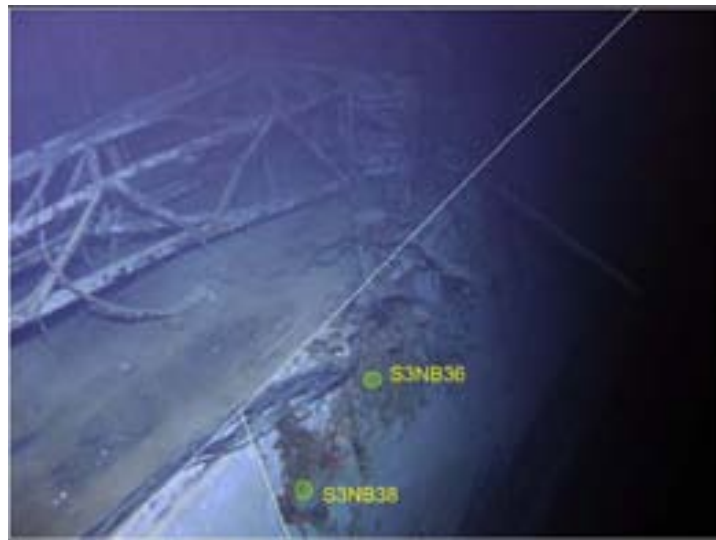

Figure 341: In vicinity of OA's Workshop, Lower deck [373]

**S4FB37**

Image : FSF.002.0303 (see Figure 342)  
 Location : Platform deck, No. 1 Cable Passage (see Figure 131)  
 Side : Starboard  
 Probable Cause : Shell penetration  
 Probable Weapon : 15 cm HE Shell  
 Armour Thickness: 164 lbs (104.1 mm)

This shell has contacted the hull at an acute angle from the forward direction and has detonated on the surface. This has resulted in a penetration to the armour plating. This hit would have resulted in many fragments being thrown into the No. 1 Cable Passage.

DSTO-GD-0559



Figure 342: In vicinity of No. 1 Cable Passage, Platform deck [309]

### S3NB38

Image : FSF.002.0301 (see Figure 341)  
 Location : Lower deck, OA's Workshop (see Figure 131)  
 Side : Starboard  
 Probable Cause : Non-penetrating contact detonation  
 Probable Weapon : 15 cm HE Shell  
 Armour Thickness: 164 lbs (104.1 mm)

### S3FB40

Image : FSF.002.0298 (see Figure 343)  
 Location : Lower deck, ERA's Dressing Room (see Figure 131)  
 Side : Starboard  
 Probable Cause : Shell penetration  
 Probable Weapon : 15 cm HE Shell  
 Armour Thickness: 164 lbs (104.1 mm)

This shell has penetrated into the ERA's Dressing Room and has possibly detonated internally.

DSTO-GD-0559

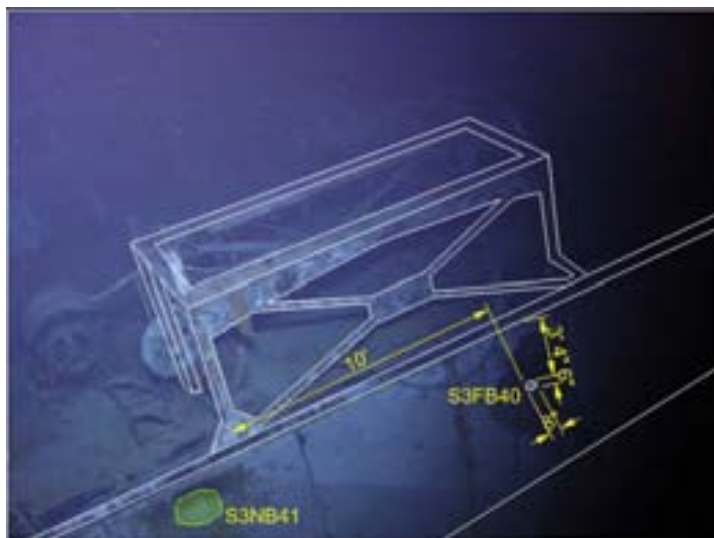

Figure 343: In vicinity of ERA's Dressing room, Lower deck and below 27 ft Whaler [374]

#### S3NB41

Image : FSF.002.0291 (see Figure 344)  
 Location : Lower deck, ERA's Wash Place (see Figure 132)  
 Side : Starboard  
 Probable Cause : Non-penetrating contact detonation  
 Probable Weapon : 15 cm HE Shell  
 Armour Thickness : 164 lbs (104.1 mm)

This shell detonation would have sprayed fragments into the 27' Whaler.

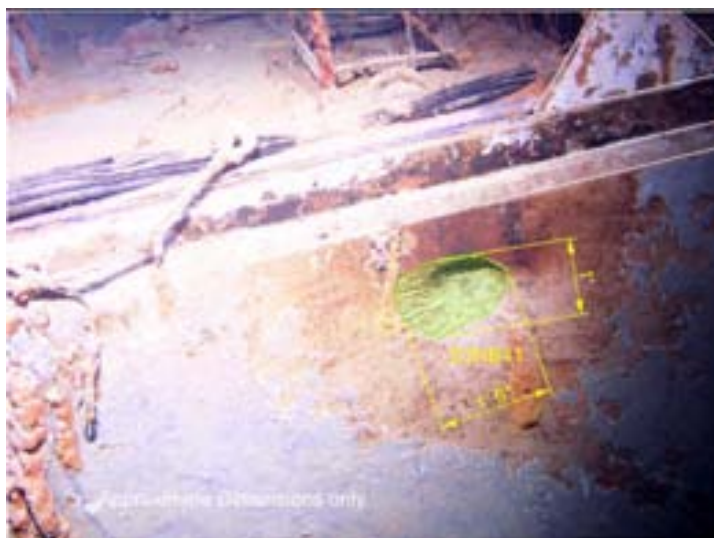

Figure 344: In vicinity of ERA's Wash Place and below starboard side 27 ft whaler [375]

#### S3NB42

Image : FSF.002.0289 (see Figure 345)  
 Location : Lower deck, Day Man's Wash Place (see Figure 132)  
 Side : Starboard

DSTO-GD-0559

Probable Cause : Non-penetrating contact detonation  
 Probable Weapon : 15 cm HE Shell  
 Armour Thickness: 164 lbs (104.1 mm)

This shell hit would not have caused any internal damage.

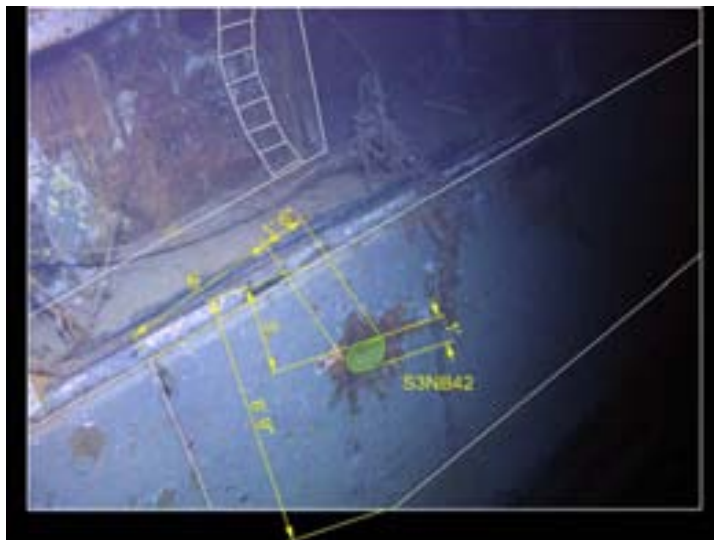
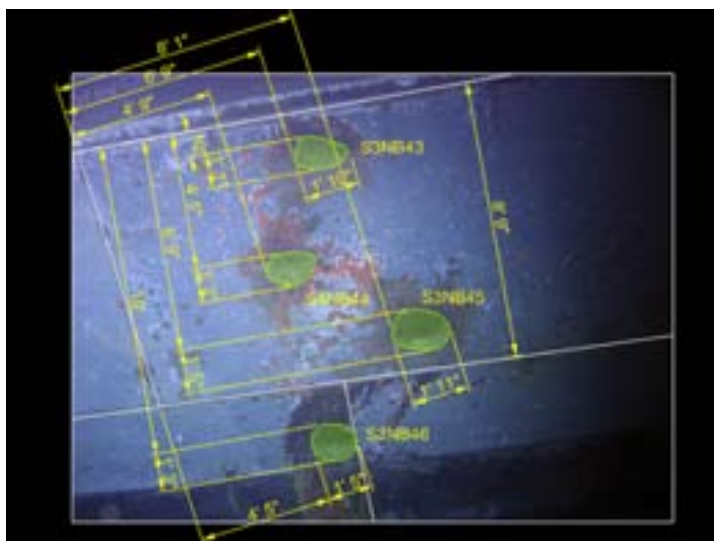

Figure 345: In vicinity of Day Man's Wash Place, Lower deck [376]

### S3NB43

Image : FSF.002.0284 (see Figure 346)  
 Location : Lower deck, Chief Stoker's Wash Place (see Figure 132)  
 Side : Starboard  
 Probable Cause : Non-penetrating contact detonation  
 Probable Weapon : 15 cm HE Shell  
 Armour Thickness: 164 lbs (104.1 mm)

This is a non-penetrating shell hit and would not have caused internal damage. Some fragments from this detonation may have damaged the superstructure above.



DSTO-GD-0559

*Figure 346: In vicinity of Chief Stoker's Wash Place, Lower deck [377]*

**S3NB44**

Image : FSF.002.0284 (see Figure 346)  
 Location : Lower deck, Chief Stoker's Wash Place (see Figure 132)  
 Side : Starboard  
 Probable Cause : Non-penetrating contact detonation  
 Probable Weapon : 15 cm HE Shell  
 Armour Thickness: 164 lbs (104.1 mm)

This is a non-penetrating shell hit and would not have caused internal damage.

**S3NB45**

Image : FSF.002.0284 (see Figure 346)  
 Location : Lower deck, Chief Stoker's Wash Place (see Figure 132)  
 Side : Starboard  
 Probable Cause : Non-penetrating contact detonation  
 Probable Weapon : 15 cm HE Shell  
 Armour Thickness: 164 lbs (104.1 mm)

This is a non-penetrating shell hit and would not have caused internal damage.

**S3NB46**

Image : FSF.002.0284 (see Figure 346)  
 Location : Platform deck, Engineer's and Lube Oil Store (see Figure 132)  
 Side : Starboard  
 Probable Cause : Non-penetrating contact detonation  
 Probable Weapon : 15 cm HE Shell  
 Armour Thickness: 164 lbs (104.1 mm)

This is a non-penetrating shell hit and would not have caused internal damage.

**S1FB47**

Image : FSF.004.0194 (see Figure 347)  
 Location : Upper deck, 4" HA Ammunition Locker (see Figure 132)  
 Side : Starboard  
 Probable Cause : Weapon damage  
 Probable Weapon : Unknown

The 4" Ammunition Locker has been either hit by a German shell, or hit by a fragment causing sympathetic detonation of a 4" shell within the locker. All of the 4" HA Ammunition Lockers in this area have become detached from the mounting brackets (see Figure 347). This is either due to the detonation or due to damage during sinking. There is potential for fragment damage to the equipment on the surrounding deck, including the Carley Floats on these decks (see Figure 349).

DSTO-GD-0559

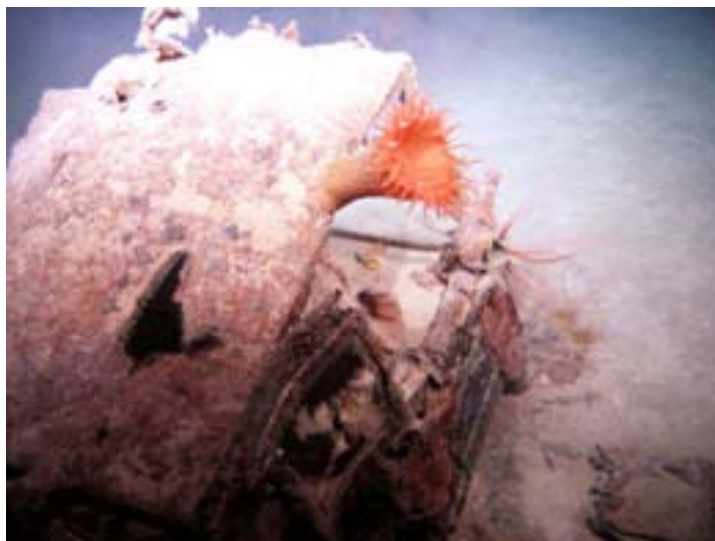

Figure 347: 4" HA Ammunition Locker in debris field [378]

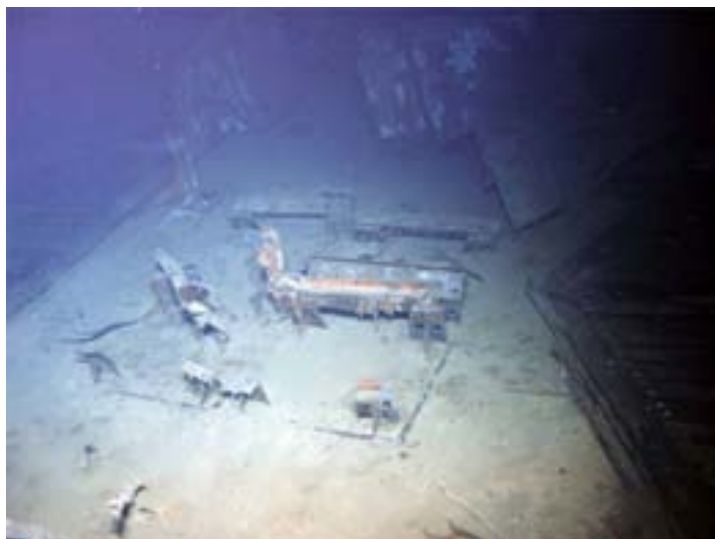

Figure 348: Starboard 4" HA Ammunition Locker mounting positions [379]



DSTO-GD-0559

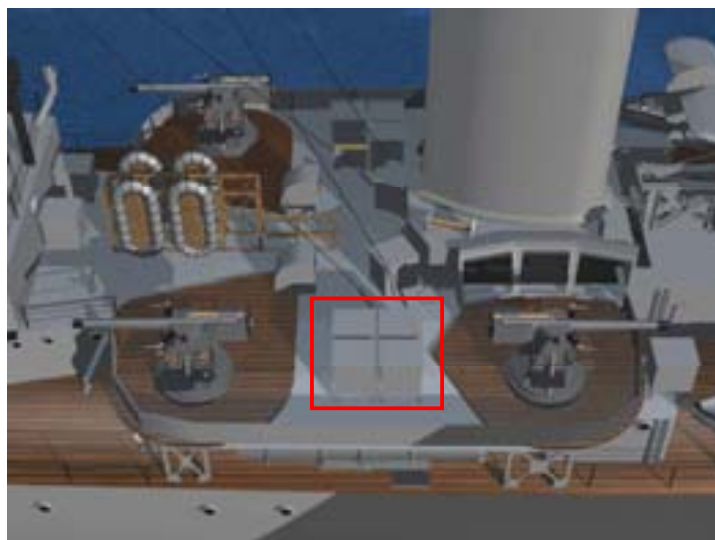

Figure 349: Structure on 4" HA Gun deck. Ammunition lockers highlighted in red.

#### S3FB48

Image : FSF.002.0272 (see Figure 350)  
 Location : Lower deck, No. 1 Cabin (see Figure 132)  
 Side : Starboard  
 Probable Cause : Shell penetration  
 Probable Weapon : 15 cm HE Shell  
 Hull Thickness : 35 lbs (22.2 mm)

This is a clean penetration in the No. 1 Cabin which would have detonated internally.



Figure 350: In vicinity of No. 1 Cabin, Lower deck [380]

#### S1FB49

Image : FSF.003.0032 (see Figure 330)  
 Location : Forecastle deck, Captain's Galley or WO's Galley (see Figure 132)

DSTO-GD-0559

Side : Starboard  
 Probable Cause : Shell Penetration  
 Probable Weapon : 15 cm HE Shell

This shell appears to have cleanly penetrated the Galley and possibly detonated internally.

**S2FB51**

Image : Screen capture from FSF Dive 2 File 145 (see Figure 351)  
 Location : Upper deck, Captain's Bath (see Figure 133)  
 Side : Starboard  
 Probable Cause : Shell penetration  
 Probable Weapon : 15 cm HE Shell

This is a shell penetration into the Captain's Bath area. This shell hit is also possibly associated with damage at S2FA39 where the shell may have detonated.

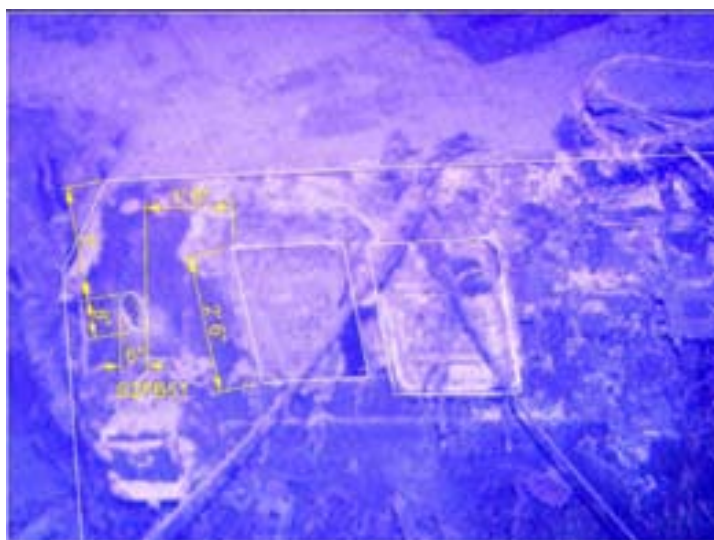

Figure 351: In vicinity of Captain's Bath, Upper deck [343]

**S1FB52**

Image : FSF.002.0278 (see Figure 352)  
 Location : Above starboard side torpedo tube mount (see Figure 132)  
 Side : Starboard  
 Probable Cause : Contact Detonation  
 Probable Weapon : 15 cm HE Shell

This damage is possibly associated with the damage to the 4" HA Ammunition Lockers on the starboard side (S1FB47).

DSTO-GD-0559



Figure 352: Starboard side torpedo tube mounting [381]

#### A.1.9 Starboard side damage – Class C Damage

##### S3FC01

Image : FSF.002.0324 (see Figure 318)  
 Location : Lower deck, No. 3 Lower Mess (see Figure 129)  
 Side : Starboard  
 Probable Cause : Fragment from contact detonation  
 Probable Weapon : 15 cm HE Shell

This damage is likely to be a result of the shell hit at S3FA07.

##### S3FC02

Image : FSF.002.0324 (see Figure 318)  
 Location : Lower deck, No. 3 Lower Mess (see Figure 129)  
 Side : Starboard  
 Probable Cause : Fragment from contact detonation  
 Probable Weapon : 15 cm HE Shell

This damage is likely to be a result of the shell hit at S3FA07.

##### S1FC03

Image : FSF.002.0319 (see Figure 353)  
 Location : Forecastle deck, Recreation Space (see Figure 129)  
 Side : starboard  
 Probable Cause : Fragment damage due to external detonation\Shell Penetration  
 Probable Weapon : 15 cm HE Shell\3.7 cm Shell

This door has a number of penetrations. Assuming that the door was closed, this damage is a result of either externally generated fragments (i.e. a 15 cm HE Shell in the vicinity) or possibly due to a series of 3.7 cm shell holes. Due to the irregular shape of the holes suggests that the damage is due to fragments from a 15 cm HE Shell, but the linear pattern suggests that it could be the result of automatic weapons fire.

DSTO-GD-0559

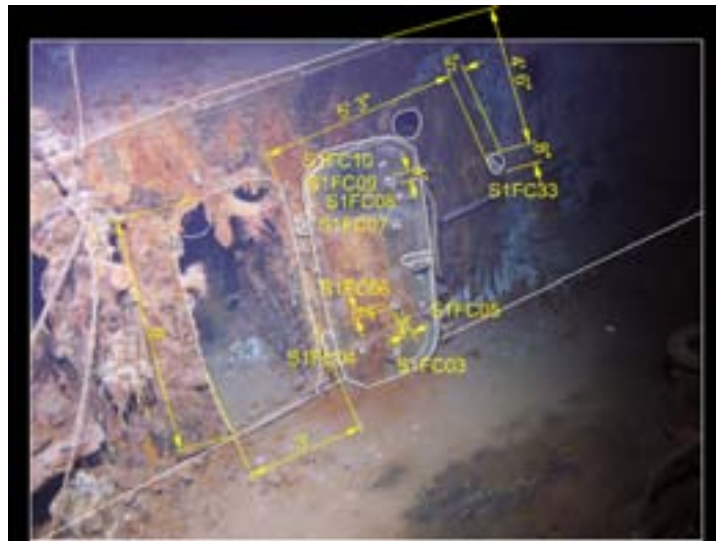

Figure 353: In vicinity of Recreation Space, Forecastle deck [187]

#### S1FC04

Image : FSF.002.0319 (see Figure 353)  
 Location : Forecastle deck, Recreation Space (see Figure 129)  
 Side : starboard  
 Probable Cause : Fragment damage due to external detonation\Shell Penetration  
 Probable Weapon : 15 cm HE Shell\3.7 cm Shell

See S1FC03.

#### S1FC05

Image : FSF.002.0319 (see Figure 353)  
 Location : Forecastle deck, Recreation Space (see Figure 129)  
 Side : starboard  
 Probable Cause : Fragment damage due to external detonation\Shell Penetration  
 Probable Weapon : 15 cm HE Shell\3.7 cm Shell

See S1FC03.

#### S1FC06

Image : FSF.002.0319 (see Figure 353)  
 Location : Forecastle deck, Recreation Space (see Figure 129)  
 Side : starboard  
 Probable Cause : Fragment damage due to external detonation\Shell Penetration  
 Probable Weapon : 15 cm HE Shell\3.7 cm Shell

See S1FC03.

#### S1FC07

Image : FSF.002.0319 (see Figure 353)  
 Location : Forecastle deck, Recreation Space (see Figure 129)  
 Side : starboard  
 Probable Cause : Fragment damage due to external detonation\Shell Penetration

DSTO-GD-0559

Probable Weapon : 15 cm HE Shell\3.7 cm Shell

See S1FC03.

#### **S1FC08**

Image : FSF.002.0319 (see Figure 353)  
 Location : Forecastle deck, Recreation Space (see Figure 129)  
 Side : starboard  
 Probable Cause : Fragment damage due to external detonation\Shell Penetration  
 Probable Weapon : 15 cm HE Shell\3.7 cm Shell

See S1FC03.

#### **S1FC09**

Image : FSF.002.0319 (see Figure 353)  
 Location : Forecastle deck, Recreation Space (see Figure 129)  
 Side : starboard  
 Probable Cause : Fragment damage due to external detonation\Shell Penetration  
 Probable Weapon : 15 cm HE Shell\3.7 cm Shell

See S1FC03.

#### **S1FC10**

Image : FSF.002.0319 (see Figure 353)  
 Location : Forecastle deck, Recreation Space (see Figure 129)  
 Side : starboard  
 Probable Cause : Fragment damage due to external detonation\Shell Penetration  
 Probable Weapon : 15 cm HE Shell\3.7 cm Shell

See S1FC03.

#### **S3FC12**

Image : FSF.002.0309 (see Figure 322)  
 Location : Lower deck, Stoker's Mess (see Figure 130)  
 Side : Starboard  
 Probable Cause : Fragment from internal detonation.  
 Probable Weapon : 15 cm HE Shell

There are a considerable number of hits to the port side of the Stoker's Mess (P3FB19, P3FB22 and P3FB27) and this fragment damage is likely associated with one of these hits.

#### **S3FC13**

Image : FSF.002.0309 (see Figure 322)  
 Location : Lower deck, Stoker's Mess (see Figure 130)  
 Side : Starboard  
 Probable Cause : Fragment from internal detonation.  
 Probable Weapon : 15 cm HE Shell

See S3FC12.

DSTO-GD-0559

### S3FC15

Image : FSF.002.0309 (see Figure 322)  
 Location : Lower deck, Stoker's Mess (see Figure 130)  
 Side : Starboard  
 Probable Cause : Fragment from internal detonation.  
 Probable Weapon : 15 cm HE Shell

See S3FC12.

### S1FC33

Image : FSF.002.0319 (see Figure 353)  
 Location : Forecastle deck, Seaman's Heads (see Figure 129)  
 Side : starboard  
 Probable Cause : Fragment damage  
 Probable Weapon : 15 cm HE Shell

This damage appears to have been caused by fragments from a shell detonating inside the ship.

### S1FC34

Image : FSF.002.0321 (see Figure 354)  
 Location : Forecastle deck, Seaman's Heads (see Figure 129)  
 Side : starboard  
 Probable Cause : Fragment damage  
 Probable Weapon : 15 cm HE Shell

See S1FC33.



Figure 354: In vicinity of Seaman's Heads [188]

### S1FC35

Image : FSF.002.0321 (see Figure 354)  
 Location : Forecastle deck, Seaman's Heads (see Figure 129)  
 Side : starboard

DSTO-GD-0559

Probable Cause : Fragment damage  
Probable Weapon : 15 cm HE Shell

See S1FC33.

*This page intentionally blank*



## Appendix B: HMAS *Sydney* – As Fitted Drawings

The construction of any warship requires many thousands of drawings to describe every part of her structure and outfit. *Sydney* was one of three ships built to the same design, and all would have been built to the same set of principal working drawings. When several ships were built to the same design by different yards, it was usual for one yard to be designated 'lead yard' and that yard would be responsible for the preparation of most of the working drawings for the class. For the Modified Leander Class cruisers most of the surviving working drawings were prepared either HM Dockyard Devonport, builders of HMS *Apollo* (later HMAS *Hobart*) or HM Dockyard Portsmouth, builders of HMS *Amphion* (later HMAS *Perth*). The latter dockyard was the lead yard for the class [67]

Despite the commonality of the basic drawings, shipbuilding practices of the time allowed individual shipbuilders considerable freedom with details of construction, provided they met Admiralty practices and standards, in accordance with the ship's specification and were to the satisfaction of the Overseer. Consequently, there would have been minor differences between all the ships of the class and not all of these differences would be recorded in the working drawings.

In order to provide a permanent record of the essential details of each ship as actually built, the specification required that the shipbuilder prepare a set of 'fitted general and other drawings' in accordance with the specification and 'usual Service practice' to record the details of each ship as actually constructed [98]. The originals were to be prepared on linen tracing cloth, often in colour, and copies were to be provided for the ship, the Admiralty and the Dockyard responsible for the refit of the ship. These drawings are usually known as 'As Fitted' drawings although, today, other terms might be used to describe drawings with the same function.

Most of the hull 'As Fitted' drawings for *Sydney* survive in series MP551/1 in the National Archives of Australia in Canberra, along with nearly a thousand working drawings. Unfortunately very few machinery or electrical drawings have been located apart from some limited machinery information found in the RAN Historical Repository in Sydney. No electrical or machinery working drawings appear to have survived.

The surviving 'As Fitted' drawings of *Sydney* are generally in excellent condition (although some have been water damaged). The General Arrangement drawings are particularly fine examples and are very informative. These drawings have been used as the basis for the tracings prepared by DSTO and used for many of the sketches and overlays in this report. The original 'As Fitted' General Arrangement drawings are reproduced on the following pages. These drawings have been updated to 1937.

*This page intentionally blank*

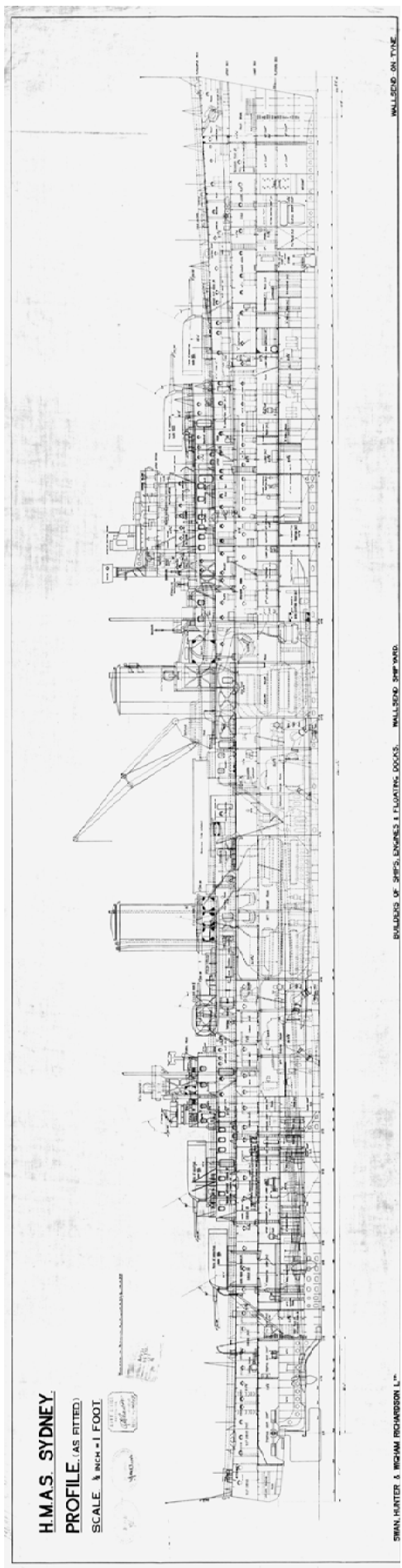

Figure 1: HMAS Sydney, Profile (As Fitted) [1]

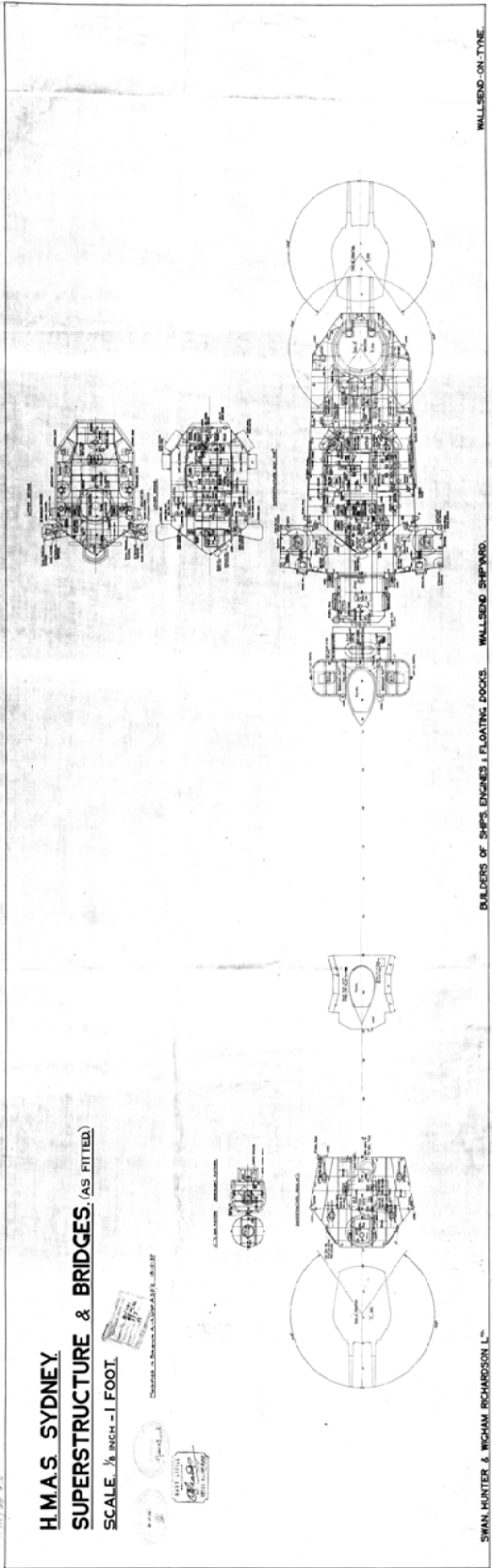

Figure 2: HMAS Sydney, Superstructure & Bridges (As Fitted) [6]

*This page intentionally blank*

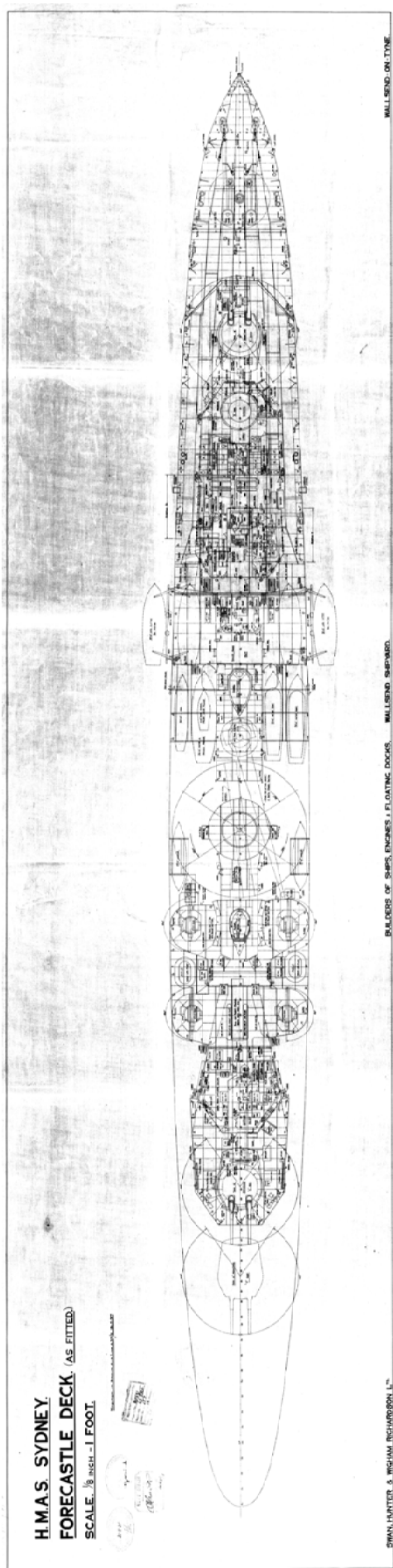

Figure 3: HMAS Sydney, Forecastle Deck (As Fitted) [2]

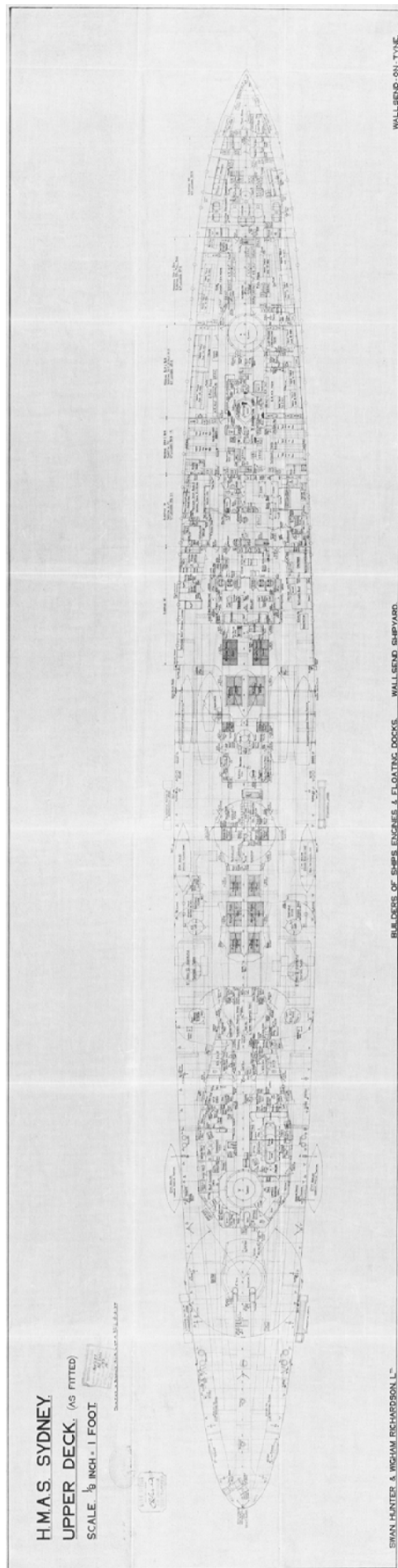

Figure 4: HMAS Sydney, Upper Deck (As Fitted) [58]

*This page intentionally blank*

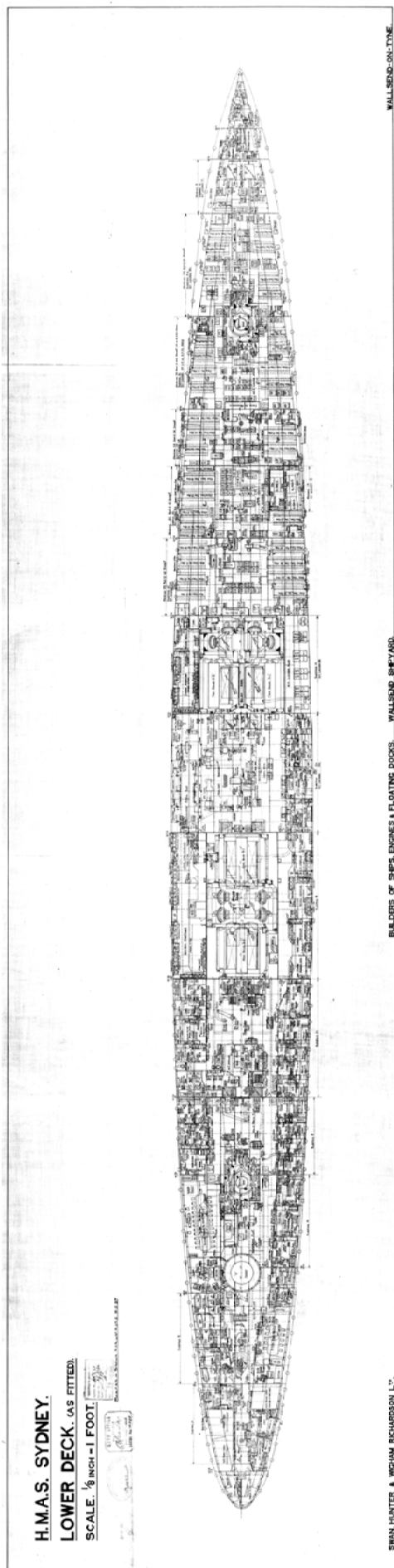

Figure 5: HMAS Sydney, Lower Deck (As Fitted) [3]

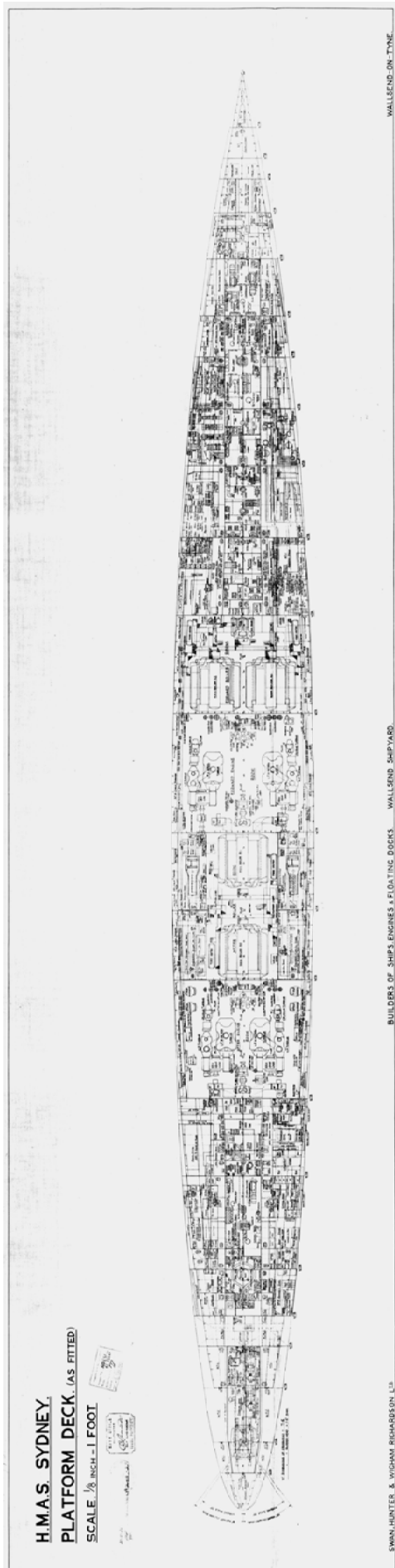

Figure 6: HMAS Sydney, Platform Deck (As Fitted) [4]

*This page intentionally blank*



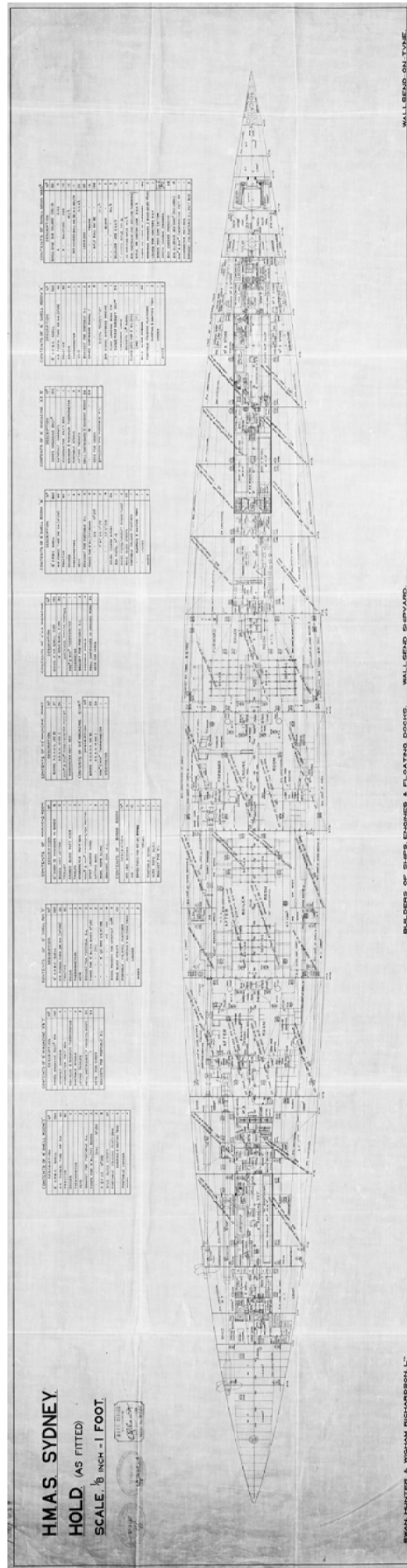

Figure 7: HMAS Sydney, Hold (As Fitted) [7]

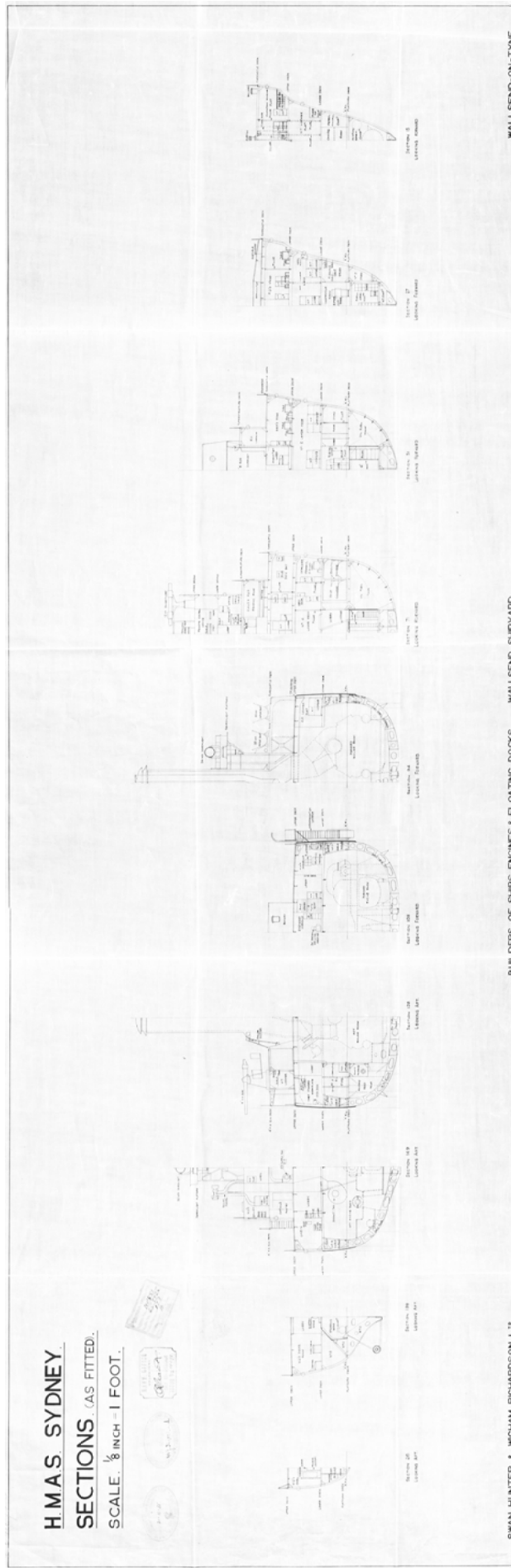

Figure 8: HMAS Sydney, Sections (As Fitted) [23]

*This page intentionally blank*

## Appendix C: Visualisations of HMAS Sydney

These visualisations are on the attached CD.

*Sequence 1: Simulated 360 degree fly-around of HMAS Sydney (40 seconds).*

This is a computer-generated fly-around of HMAS *Sydney II*. The model was developed from original builder's plans. It was then fine-tuned as additional information became available from other historical documents and photographs, and from interpretation of the video imagery derived from the vessel's wreckage and debris field.

The model was developed to assist the DSTO scientists and RINA technical experts in their interpretation of the cause and significance of the damage to various parts of the ship.

Given the flexibility of computer-based simulation and graphics, it was also possible to simulate proposed scenarios for the engagement between the two ships, and its aftermath. Hence it was possible to perform 'reality checks' on a number of proposed battle scenarios.

*Sequence 2: Real-time representation of the first part of the engagement between the two vessels (109 seconds).*

Based principally on evidence that can be derived from the wreckage of the two ships (their relative positions, the damage to each vessel, the distribution of wreckage in the debris field, etc) and accounts of the battle, it has been possible to assemble a representative approximation of the order-of-battle for the first minute or so of the engagement. It has not been possible to definitively establish the order in which various shell hits were sustained on the two vessels. Assumptions upon which this computer simulation is based include:

1. HSK *Kormoran* fired a torpedo very early in the engagement;
2. HSK *Kormoran* fired a salvo with its 15 cm guns which struck HMAS *Sydney* in the vicinity of its bridge, almost certainly incapacitating the command crew;
3. HMAS *Sydney* responded with a full salvo from its six inch guns;
4. Having started a fire in the midship region with a hit under HMAS *Sydney's* aircraft, HSK *Kormoran* shifted the focus of fire for her 15 cm guns to HMAS *Sydney's* forward turrets; while also firing 3.7 cm and 20 mm gun fire into HMAS *Sydney's* secondary armament;
5. HMAS *Sydney's* forward turrets fell silent but her aft turrets continued to fire on HSK *Kormoran*, with X turret being particularly effective;
6. At some time during this phase of the engagement, HMAS *Sydney's* port side sea cutter was lost overboard;
7. The torpedo, which travels much slower than shells, struck HMAS *Sydney* on her port side, forward of A Turret. HMAS *Sydney* very quickly settled down by the bows.
8. While the ships continued to exchange fire, HMAS *Sydney* turned hard to port, aiming to cross HSK *Kormoran's* stern;

DSTO-GD-0559

9. At around this time HMAS *Sydney*'s X and Y Turrets lost the ability to train, so her guns were no longer able to be brought to bear on HSK *Kormoran*;

This was the end of the first phase of the engagement.

*Sequence 3: HMAS Sydney, port side aggregation of damage from 15 cm shells (9 seconds).*

This video sequence aggregates all of the 15 cm shell hits on HMAS *Sydney*'s port side into a single time sequence. That is, it presents all of the hits as if they struck the HMAS *Sydney* at the same time. The purpose of doing so is to illustrate the comprehensive nature of HSK *Kormoran*'s heavy gun bombardment. It is important to appreciate HMAS *Sydney* sustained similar damage to the starboard side. There are a few points to note:

1. The size of the 'spray' of each hit is representative of the lethal radius for blast and shrapnel-damage effects;
2. No attempt has been made to differentiate between hits that detonated on impact with the ship and those which penetrated the ship and detonated inside. In either case the damage would have been devastating;
3. In addition to this 15 cm gunfire, HSK *Kormoran* was firing smaller calibre (3.7 cm and 20 mm gun) weapons into HMAS *Sydney*'s bridge, exposed decks which included the four inch armament and torpedo tubes. These were located near the aft funnel and are visible astern of the main body of the 15 cm shell hits.

*Sequence 4: HMAS Sydney, turn to port while under fire (61 seconds).*

This video sequence shows HMAS *Sydney* turning to port. The sequence is showing a compressed timeframe (61 seconds) of a sequence that could have lasted 50 minutes from the time HMAS *Sydney* started turning to port. There are a few points to note:

1. HSK *Kormoran* continued to fire but was only able to bear two 15 cm guns on HMAS *Sydney* during the turning manoeuvre;
2. The first shots from HSK *Kormoran* fired over the bow of HMAS *Sydney* and destroyed the starboard plate of HMAS *Sydney*'s A turret;
3. The order of the numerous other hits on HMAS *Sydney*'s starboard side have been shown striking HMAS *Sydney* from the bow towards the stern. This is necessarily the correct order but is simply to show the extent and locations of the 15 cm shell strikes.

4. *Sequence 5: Representation of HMAS Sydney late in the evening (34 seconds).*

The HSK *Kormoran* crew reported that, as HMAS *Sydney* limped away from the scene of the battle, they continued to see the glow of HMAS *Sydney's* fires until about 11 pm. Assessments by DSTO scientists and RINA technical experts indicate that HMAS *Sydney* would have continued to sustain uncontrollable flooding due to both torpedo and gunfire damage. As time went on HMAS *Sydney* would have sunk lower in the water, and would have taken on a significant list to port. Because of the tremendous weight of water inside the hull, HMAS *Sydney* would have taken on a wallowing motion. Additionally, the survival of HMAS *Sydney* was adversely affected by a deterioration in sea conditions and a wave height of approximately 2.5 m later in the evening. This simulation gives some appreciation of the probable state of the ship shortly before HMAS *Sydney* sank.

Page classification: UNCLASSIFIED

| <b>DEFENCE SCIENCE AND TECHNOLOGY ORGANISATION<br/>DOCUMENT CONTROL DATA</b>  |                     |                             |   |  | 1. PRIVACY MARKING/CAVEAT (OF DOCUMENT) |                                  |
|---|---------------------|-----------------------------|---|--|---|----------------------------------|
| 2. TITLE<br><br>HMAS Sydney II Commission of Inquiry<br><br>Report on Technical Aspects of the Sinking of HMAS Sydney and HSK Kormoran  |                     |                             | 3. SECURITY CLASSIFICATION (FOR UNCLASSIFIED REPORTS THAT ARE LIMITED RELEASE USE (L) NEXT TO DOCUMENT CLASSIFICATION)<br><br>Document (U)<br>Title (U)<br>Abstract (U) |  |   |                                  |
| 4. AUTHOR(S)<br><br>M. Buckland, S.M. Cannon, L. de Yong, G.I. Gamble, J.C. Jeremy, T. Lyon, P. McCarthy, B. Morris, R.A. Neill, M.B. Skeen, B. Suendermann and T. Turner   |                     |                             | 5. CORPORATE AUTHOR<br><br>DSTO Defence Science and Technology Organisation<br>506 Lorimer St<br>Fishermans Bend Victoria 3207 Australia                                |  |   |                                  |
| 6a. DSTO NUMBER<br>DSTO-GD-0559   |                     | 6b. AR NUMBER<br>AR-013-353 |   | 6c. TYPE OF REPORT<br>General Document |   | 7. DOCUMENT DATE<br>January 2009 |
| 8. FILE NUMBER<br>-   | 9. TASK NUMBER<br>- | 10. TASK SPONSOR<br>-       |   | 11. NO. OF PAGES<br>389                |   | 12. NO. OF REFERENCES<br>381     |
| 13. URL on the World Wide Web<br><br><a href="http://www.dsto.defence.gov.au/corporate/reports/DSTO-GD-0559.pdf">http://www.dsto.defence.gov.au/corporate/reports/DSTO-GD-0559.pdf</a>  |                     |                             | 14. RELEASE AUTHORITY<br><br>Chief, Maritime Platforms Division   |  |   |                                  |
| 15. SECONDARY RELEASE STATEMENT OF THIS DOCUMENT<br><br><i>Approved for public release</i>  |                     |                             |   |  |   |                                  |
| OVERSEAS ENQUIRIES OUTSIDE STATED LIMITATIONS SHOULD BE REFERRED THROUGH DOCUMENT EXCHANGE, PO BOX 1500, EDINBURGH, SA 5111   |                     |                             |   |  |   |                                  |
| 16. DELIBERATE ANNOUNCEMENT<br><br>No Limitations   |                     |                             |   |  |   |                                  |
| 17. CITATION IN OTHER DOCUMENTS Yes   |                     |                             |   |  |   |                                  |
| 18. DSTO RESEARCH LIBRARY THESAURUS <a href="http://web-vic.dsto.defence.gov.au/workareas/library/resources/dsto_thesaurus.shtml">http://web-vic.dsto.defence.gov.au/workareas/library/resources/dsto_thesaurus.shtml</a><br><br>HMAS Sydney; Naval architecture; Naval shipwrecks; Maritime archeology; Shipbuilding; HSK Kormoran   |                     |                             |   |  |   |                                  |
| 19. ABSTRACT<br><br>This report describes the technical findings of the battle and sinking of HMAS Sydney and HSK Kormoran based on historical and archeological evidence. The battle occurred on the 19 <sup>th</sup> of November, 1941 off the West Australian coast. The wrecks of the two ships were discovered in March 2008 and their subsequent underwater exploration has shed light on the events that took place during and after the battle.<br><br>This report was presented to the HMAS Sydney II Commission of Inquiry by the Defence Science and Technology Organisation (DSTO) and the Australian Division of the Royal Institution of Naval Architects (RINA) in January 2009. |                     |                             |   |  |   |                                  |

Page classification: UNCLASSIFIED