

Geometry - Basic, Teacher's  
Edition (Being Reviewed)



# Geometry - Basic, Teacher's Edition (

---

Kate Dirga, (KateD)

Lori Jordan, (LoriJ)

**Say Thanks to the Authors**

Click <http://www.ck12.org/saythanks>

*(No sign in required)*

To access a customizable version of this book, as well as other interactive content, visit [www.ck12.org](http://www.ck12.org)

CK-12 Foundation is a non-profit organization with a mission to reduce the cost of textbook materials for the K-12 market both in the U.S. and worldwide. Using an open-content, web-based collaborative model termed the **FlexBook®**, CK-12 intends to pioneer the generation and distribution of high-quality educational content that will serve both as core text as well as provide an adaptive environment for learning, powered through the **FlexBook Platform®**.

Copyright © 2012 CK-12 Foundation, [www.ck12.org](http://www.ck12.org)

The names “CK-12” and “CK12” and associated logos and the terms “**FlexBook®**” and “**FlexBook Platform®**” (collectively “CK-12 Marks”) are trademarks and service marks of CK-12 Foundation and are protected by federal, state, and international laws.

Any form of reproduction of this book in any format or medium, in whole or in sections must include the referral attribution link <http://www.ck12.org/saythanks> (placed in a visible location) in addition to the following terms.

Except as otherwise noted, all CK-12 Content (including CK-12 Curriculum Material) is made available to Users in accordance with the Creative Commons Attribution/Non-Commercial/Share Alike 3.0 Unported (CC BY-NC-SA) License (<http://creativecommons.org/licenses/by-nc-sa/3.0/>), as amended and updated by Creative Commons from time to time (the “CC License”), which is incorporated herein by this reference.

Complete terms can be found at <http://www.ck12.org/terms>.

Printed: May 14, 2012

**flexbook**  
next generation textbooks



## AUTHORS

Kate Dirga, (KateD)

Lori Jordan, (LoriJ)

<b>1</b>	<b>Basic Geometry TE - Teaching Tips</b>	<b>1</b>
1.1	Basics of Geometry . . . . .	2
1.2	Reasoning and Proof . . . . .	8
1.3	Parallel and Perpendicular Lines . . . . .	13
1.4	Triangles and Congruence . . . . .	21
1.5	Relationships with Triangles . . . . .	27
1.6	Polygons and Quadrilaterals . . . . .	33
1.7	Similarity . . . . .	39
1.8	Right Triangle Trigonometry . . . . .	46
1.9	Circles . . . . .	52
1.10	Perimeter and Area . . . . .	60
1.11	Surface Area and Volume . . . . .	65
1.12	Rigid Transformations . . . . .	72
<b>2</b>	<b>Basic Geometry TE - Common Errors</b>	<b>78</b>
2.1	Basics of Geometry . . . . .	79
2.2	Reasoning and Proof . . . . .	84
2.3	Parallel and Perpendicular Lines . . . . .	91
2.4	Triangles and Congruence . . . . .	98
2.5	Relationships with Triangles . . . . .	103
2.6	Polygons and Quadrilaterals . . . . .	109
2.7	Similarity . . . . .	115
2.8	Right Triangle Trigonometry . . . . .	121
2.9	Circles . . . . .	127
2.10	Perimeter and Area . . . . .	133
2.11	Surface Area and Volume . . . . .	137
2.12	Rigid Transformations . . . . .	145

---

**CHAPTER 1**

# Basic Geometry TE - Teaching Tips

## CHAPTER OUTLINE

---

- 1.1 BASICS OF GEOMETRY**
  - 1.2 REASONING AND PROOF**
  - 1.3 PARALLEL AND PERPENDICULAR LINES**
  - 1.4 TRIANGLES AND CONGRUENCE**
  - 1.5 RELATIONSHIPS WITH TRIANGLES**
  - 1.6 POLYGONS AND QUADRILATERALS**
  - 1.7 SIMILARITY**
  - 1.8 RIGHT TRIANGLE TRIGONOMETRY**
  - 1.9 CIRCLES**
  - 1.10 PERIMETER AND AREA**
  - 1.11 SURFACE AREA AND VOLUME**
  - 1.12 RIGID TRANSFORMATIONS**
-

# 1.1 Basics of Geometry

## Author's Note

This component of the Teacher's Edition for the Basic Geometry FlexBook is designed to help teacher's lesson plan. Suggestions for block planning, daily supplemental activities, and study skills tips are also included. It is recommended to hand out the Study Guides (at the end of each chapter and print-ready) at the beginning of each chapter and fill it out as the chapter progresses.

The Review Queue at the beginning of each section in the FlexBook is designed to be a warm-up for the beginning of each lesson and is intended to be done at the beginning of the period. Answers are at the end of each section.

The Know What? at the beginning of each section in the FlexBook is designed as a discussion point for the beginning of a lesson and then answered at the conclusion of the lesson. It can be added to homework or done as an end-of-the-lesson "quiz" to assess how students are progressing.

Throughout the text there are investigations pertaining to theorems or concepts within a lesson. These investigations may be constructions or detailed drawings that are designed to steer students towards discovering a theorem or concept on their own. This is a hands-on approach to learning the material and usually received well by low-level students. It provides them an opportunity to gain ownership of the material without being told to accept something as truth. These investigations may use: a ruler (or straightedge), compass, protractor, pencil/pen, colored pencils, construction paper, patty paper, or scissors. They can be done as a teacher-led activity, as a group, in pairs, or as an individual activity. If you decide to make an investigation teacher-led, have the students follow along, answer the questions in the text, and then draw their own conclusions. In a block period setting, these activities could be done as a group (because activities seem to take longer when students work in groups) with each group member owning a particular role. One or two students can do the investigation, one can record the group's conclusions, and one can report back to the class.

At the beginning of the Review Questions, there is a bulleted list with the examples that are similar to which review questions. Encourage students to use this list to and then reference the examples to help them with their homework.

In the Pacing sections for each chapter, consider each "Day" a traditional 50-minute period. For block scheduling, group two days together.

## Pacing

**TABLE 1.1:**

<b>Day 1</b> <i>Points, Lines, and Planes</i>	<b>Day 2</b> Continue <i>Points, Lines, and Planes</i> Investigation 1-1	<b>Day 3</b> <i>Segments and Distance</i>	<b>Day 4</b> <b>Quiz 1</b> <i>Start Angles and Measurement</i>	<b>Day 5</b> <i>Finish Angles and Measurement</i> Investigation 1-2 Investigation 1-3
<b>Day 6</b> <i>Midpoints and Bisectors</i> Investigation 1-4 Investigation 1-5	<b>Day 7</b> <b>Quiz 2</b> <i>Start Angle Pairs</i>	<b>Day 8</b> <i>Finish Angle Pairs</i> Investigation 1-6	<b>Day 9</b> <i>Classifying Polygons</i>	<b>Day 10</b> <b>Quiz 3</b> <i>Start Review of Chapter 1</i>
<b>Day 11</b> Continue Review	<b>Day 12</b> <b>Chapter 1 Test</b>	<b>Day 13</b> Continue testing (if needed) Start Chapter 2		

---

## Points, Lines, and Planes

### Goal

This lesson introduces students to the basic principles of geometry. Students will become familiar with the terms points, lines, and planes and how these terms are used to define other geometric vocabulary. Students will also be expected to correctly draw and label geometric figures.

### Study Skills Tip

Geometry is very vocabulary-intensive, unlike Algebra. Devote 5-10 minutes of each class period to thoroughly defining and describing vocabulary. Use the Study Guides at the end of each chapter to assist you with this. Also make sure that students know how to correctly label diagrams. You can use personal whiteboards to perform quick vocabulary checks. Or, visit Discovery School's puzzle maker to make word searches and crosswords (<http://puzzlemaker.discoveryeducation.com/>).

### Real World Connection

Have a class discussion to identify real-life examples of points, lines, planes in the classroom, as well as sets of collinear and coplanar. For example, points could be chairs, lines could be the intersection of the ceiling and wall, and the floor is a plane. If your chairs are four-legged, this is a fantastic example of why 3 points determine a plane, not four. Four legged chairs tend to wobble, while 3-legged stools remain stable. During this discussion, have students fill out the following table:

**TABLE 1.2:**

<i>Dimensions</i>	<i>Description</i>	<i>Geometry Representation</i>	<i>Real-Life Example(s)</i>
Zero	n/a		
One	Length		
Two	Length and width		
Three	Length, width, and height		

Students may have difficulty distinguishing the difference between a postulate and a theorem. Use real-world examples like “my eyes are blue,” for a postulate. That cannot be proven true, but we know that it is by looking (fill in your eye color). A theorem would be something like, “If the refrigerator is not working, then it is unplugged.” We can go through steps to prove (or disprove) that the fridge is unplugged. Students may conclude other reasons that would make the fridge not work (it could be broken, the fan could have gone out, it is old, etc), making this a statement that needs to be proven and cannot be accepted as true.

---

## Segments and Distance

### Goal

Students should be familiar with using rulers to measure distances. This lesson incorporates geometric postulates and properties to measurement, such as the Segment Addition Property. There is also an algebraic tie-in, finding the distance of vertical and horizontal lines on the coordinate plane.

### Notation Note

Double (and triple) check that students understand the difference between the labeling of a line segment,  $\overline{AB}$ , and its distance,  $AB$ . Even though the alternative notation,  $m\overline{AB}$ , is introduced in this section, this text primarily uses  $AB$ .

### Relevant Review

Students may need to review how to plot points and count the squares for the horizontal and vertical distances between two points. It might also be helpful add a few algebraic equations to the Review Queue. Problems involving the Segment Addition Postulate can be similar to solving an algebraic equation (Example 9).

### Real World Connection

To review the concept of measurement, use an enlarged map of your community. Label several things on your map important to students – high school, grocery store, movie theatre, etc. Have students practice finding the distances between landmarks “as the crow flies” and using different street routes to determine the shortest distance between the two.

### Teaching Strategy

The Segment Addition Postulate can seem simple to students at first. Start with basic examples, like Examples 5 and 6 and then progress to more complicated examples, like 7 and 8. Finally, introduce problems like Example 9. For more examples, see the Differentiated Instruction component. With the Segment Addition Postulate, you can start to introduce the concept of a proof. Use Example 7 and have students write out an explanation of their drawing. Tell students to use language such that the person reading their explanation knows nothing about math.

---

## Angles and Measurement

### Goal

This lesson introduces students to angles and how to use a protractor to measure them. Then, we will apply the Angle Addition Postulate in the same way as the Segment Addition Postulate.

### Notation Note

Beginning geometry students may get confused regarding the ray notation. Draw rays in different directions so students become comfortable with the concept that ray notation always has the non-arrow end over the endpoint (regardless of the direction the ray points). Reinforce that  $\overrightarrow{AB}$  and  $\overleftarrow{BA}$  represent the same ray.

### Real World Connection

Have students Think-Pair-Share their answers to the opening question, “Can you think of real-life examples of rays?” Then, open up the discussion to the whole class.

### Teaching Strategies

Using a classroom sized protractor will allow students to check to make sure their drawings are the same as yours. An overhead projector or digital imager is also a great way to demonstrate the proper way to use a protractor.

In this section, we only tell students that they can use three letters (and always three letters) to label an angle. *In Chapter 2 we introduce the shortcut.* We did not want the confusion that so commonly occurs where students will name any angle by only its vertex.

Stress the similarities between the Segment Addition Property and Angle Addition Property. Students will discover that many geometrical theorems and properties are quite similar.

Have students take a piece of paper and fold it at any angle of their choosing from the corner of the paper. Open the fold and refold the paper at a different angle, forming two “rays” and three angles. Show how the angle addition property can be used by asking students to measure their created angles and finding the sum. You can also use this opportunity to explain how angles can also be labeled as numbers,  $m\angle 1 + m\angle 2 + m\angle 3 = 90^\circ$

### 1.1. BASICS OF GEOMETRY



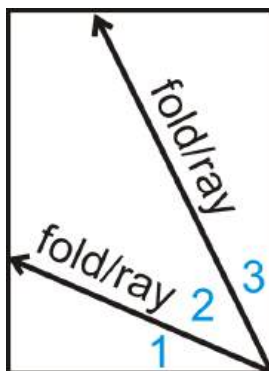

Student may need additional practice drawing and copying angles. This is the first time they have used a compass (in this course). Encourage students to play with the compass and show them how to use it to draw a circle and arcs. Once they are familiar with the compass (after 5-10 minutes), then go into Investigation 1-3. In addition to copying a  $50^\circ$  angle, it might be helpful to walk students through copying a  $90^\circ$  angle and an obtuse angle.

## Midpoints and Bisectors

### Goal

The lesson introduces students to the concept of congruency, midpoints, and bisectors. The difference between congruence and equality will also be stressed. Students will use algebra to write equivalence statements and solve for unknown variables.

### Teaching Strategies

This is a great lesson for students to create a “dictionary” of all the notations learned thus far. In addition to the Study Guide, the dictionary provides an invaluable reference before assessments.

When teaching the Midpoint Postulate, reiterate to students that this really is the arithmetic average of the endpoints, incorporating algebra and statistics into the lesson. Explain the average between two numbers, is the sum divided by 2. The midpoint of two points is the exact same idea.

Ask students to define “bisector” on their own, before discussing a perpendicular bisector (Example 4). Hopefully students will construct multiple bisectors. This will help students visualize that there are an infinite amount of bisectors, and lead them to the fact there is only one perpendicular bisector and the Perpendicular Bisector Postulate.

With Investigations 1-4 and 1-5, students may need to repeat the construction a few times. Copy a handout with several line segments and different angle measures and have them practice the construction on their own or in pairs.

In this lesson and the previous lesson, we have introduced how to make drawings. Encourage students to redraw any pictures that are in the homework so they can mark congruent segments and angles. Also, let students know that it is ok to mark on quizzes and tests (depending on your preference).

## Angle Pairs

### Goal

This lesson introduces students to common angle pairs, the Linear Angle Postulate and the Vertical Angles Theorem.

### Teaching Strategies

Students can get complementary and supplementary confused. A way to help them remember:

- C in Complementary also stands for Corner (in a right angle)

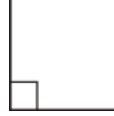

- S in Supplementary also stands for Straight (in a straight angle)



To illustrate the concept of the Linear Pair Postulate, offer several examples of linear pairs. Have students measure each angle and find the sum of the linear pair. Students should discover any linear pair is supplementary. Also explain that a linear pair must be adjacent. Discuss the difference between adjacent supplementary angles (a linear pair) and non-adjacent supplementary angles (same side interior angles, consecutive angles, or two angles in a drawing that are not next to each other).

To further illustrate the idea of vertical angles, repeat Investigation 1-6 with two different intersecting lines. Also, encourage students to draw their intersecting lines at different angles than yours. This way, they will see that no matter the angle measures the vertical angles are always equal and the linear pairs are always supplementary. Draw this investigation on a piece of white paper and have students use the whole page. Then, when they are done, have them exchange papers with the students around them to reinforce that the angle measures do not matter.

- V in Vertical angles also stands for V in Vertex. Vertical angles do not have to be “vertical” (one on top of the other). Students might get the definitions confused.

In this section there are a lot of Algebra tie-ins (Example 5, Review Questions 17-25). Students might need additional examples showing linear pairs and vertical angles with algebraic expression representations.

**Additional Example:** Find the value of  $y$ .

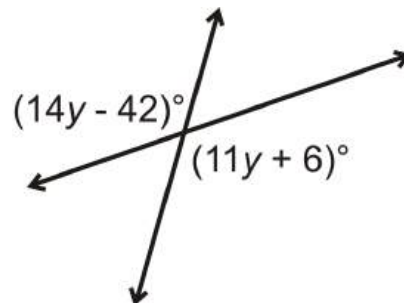

**Solution:** Because these are vertical angles, set the two expressions equal to each other.

$$\begin{aligned}(14y - 42)^\circ &= (11y + 6)^\circ \\ 3y &= 48^\circ \\ y &= 16^\circ\end{aligned}$$

---

## Classifying Polygons

### Goal

#### 1.1. BASICS OF GEOMETRY

In this lesson, we will explore the different types of triangles and polygons. Students will learn how to classify triangles by their sides and angles, as well as classify polygons by the number of sides. The definitions of convex and concave polygons will also be explored.

### Teaching Strategy

Divide students into pairs. Give each pair three raw pieces of spaghetti. Instruct one partner to break one piece of spaghetti into three pieces and attempt to construct a triangle using these segments. Students will reach the conclusion that the sum of two segments must always be larger than the third if a triangle is to be formed. *The Triangle Inequality Theorem is introduced in Chapter 4.*

Next, have students create right, obtuse, acute, scalene, isosceles, and equilateral triangles with their pieces of spaghetti. Show them that if the spaghetti pieces' endpoints are not touching, the polygon is not closed, and therefore not a polygon. You can use pieces of spaghetti on an overhead projector.

To show the difference between line segments and curves, introduce cooked spaghetti. The flexibility of the spaghetti demonstrates to students that segments must be straight in order to provide rigidity and follow the definitions of polygons.

After playing with the spaghetti, brainstorm the qualities of polygons and write them on the board (or overhead) and develop a definition. From here, you can compare and contrast convex and concave polygons. Use a Venn diagram to show the properties that overlap and those that are different.

### **Review**

At the end of this chapter there is a Symbol Toolbox with all the labels and ways to mark drawings. Have students make flash cards with the symbols and markings on one side, and what they represent on the other. Students may also want to make flash cards for the definitions for the other words in the (and future) chapters.

In addition to the Study Guide, it might be helpful to go over the constructions from this chapter. You might want to have a Construction Toolbox, where students have one example of each construction they have learned. These construction pages can supplement the Study Guide and should be added to from chapter to chapter. As an added incentive, you might want to grade students' Study Guides at the end of the chapter. Another option could be to allow students to use their Study Guide on tests and/or allow it to be extra credit. These options can change from test to test or at the teacher's discretion.

## 1.2 Reasoning and Proof

### Pacing

TABLE 1.3:

<b>Day 1</b> <i>Inductive Reasoning</i>	<b>Day 2</b> <i>Conditional Statements</i>	<b>Day 3</b> Continue <i>Conditional Statements</i> Start <i>Deductive Reasoning</i>	<b>Day 4</b> <b>Quiz 1</b> Finish <i>Deductive Reasoning</i>	<b>Day 5</b> <i>Algebraic and Congruence Properties</i>
<b>Day 6</b> <b>Quiz 2</b> Start <i>Proofs about Angle Pairs and Segments</i>	<b>Day 7</b> Finish <i>Proofs about Angle Pairs and Segments</i>	<b>Day 8</b> <b>Quiz 3</b> Review for <i>Chapter 2 Test</i>	<b>Day 9</b> More Review	<b>Day 10</b> <b>Chapter 2 Test</b> (May need to continue testing on Day 11)

### Inductive Reasoning

#### Goal

This lesson introduces students to inductive reasoning, which applies to algebraic patterns and integrates algebra with geometry.

#### Teaching Strategies

After the Review Queue do a Round Robin with difference sequences. Call on one student to say a number, call on a second student to say another number. The third student needs to distinguish the pattern and say the correct number. The fourth, fifth, sixth, etc. students need to say the correct numbers that follow the pattern. Start over whenever you feel is appropriate and repeat. To make the patterns more challenging, you can interject at the third spot (to introduce geometric sequences, Fibonacci, and squared patterns).

Now, take one of the sequences that was created by the class and ask students to try to find the rule. Ask students to recognize the pattern and write the generalization in words.

**Additional Example:** Find the next three terms of the sequence 14, 10, 15, 11, 16, 12, ...

**Solution:** Students can look at this sequence in two different ways. One is to subtract 4 and then add 5. Another way is to take the odd terms as one sequence (14, 15, 16, ...) and then the even terms as another sequence (10, 11, 12, ...). Either way, the next three terms will be 17, 13, and 18.

#### Know What? Suggestion

When going over this Know What? (the locker problem) draw lockers on the front board (as many that will fit). Have students come up to the board and mark x's to close the appropriate doors, as if they are acting out the problem. This will help students see the pattern.

#### Real Life Connection

Apply the idea of counterexample to real life situations. Begin by devising a statement, such as, "If the sun is

shining, then you can wear shorts.” While this is true for warm weather states such as Florida and California, for those living in the Midwest or Northern states, it is quite common to be sunny and  $12^{\circ}F$ . Have students create their own statements and encourage other students to find counterexamples.

## Conditional Statements

### Goal

This lesson introduces conditional statements. Students will gain an understanding of how converses, inverses, and contrapositives are formed from a conditional.

### Teaching Strategies

The first portion of this lesson may be best taught using direct instruction and visual aids. Design phrases you can laminate, such as “you are sixteen” and “you can drive.” Adhere magnets to the back of the phrases (to stick to the white board), or you can use a SMART board. Begin by writing the words “IF” and “THEN,” giving ample space to place your phrases. When discussing each type of conditional, show students how each is constructed by rearranging your phrases, yet leaving the words “IF” and “THEN” intact.

Have students create a chart listing the type of statement, its symbolic form and an example. This allows students an quick reference sheet when trying to decipher between converse, conditional, contrapositive, and inverse. The chart can be added to the Study Guide or place in class notes.

**TABLE 1.4:**

	<i>Symbolic Form</i>	<i>Example</i>	<i>True or False?</i>
<b>Conditional Statement</b>	$p \rightarrow q$		
<b>Converse</b>			
<b>Inverse</b>			
<b>Contrapositive</b>			Logically equivalent to original.

Spend time reviewing the definition of a counterexample (from the previous section). A counterexample is a quick way to disprove the converse and inverse. Explain to students that the same counterexample should work for both the converse and inverse (if they are false, see Examples 2, 3, and 7).

Use the same setup as the opening activity when discussing biconditionals. Begin with a definition, such as Example 4. Set up your magnetic phrases in if and only if form, then illustrate to students how the biconditional can be separated into its conditional and converse.

## Deductive Reasoning

### Goal

This lesson introduces deductive reasoning. Different than inductive reasoning, deductive reasoning begins with a generalized statement, and assuming the hypothesis is true, specific examples are deduced.

### Teaching Strategies

Start this lesson by writing the Know What? on the board (or copy it onto a transparency). Have the students read each door (either out loud or to themselves) and try to reason which door the peasant should pick. This discussion can lend itself to the definitions of logic and deductive reasoning.

Students may or may not realize that they do deductive reasoning every day. Explain that solving an equation is an example of deductive reasoning. Try to brainstorm, as a class, other examples of deductive reasoning and inductive reasoning.

The best way for students to understand the Laws of Detachment, Contrapositive, and Syllogism is to do lots of practice. Make sure to include problems that do not have a logical conclusion. Like in Examples 7 and 8, it might be helpful for students to put the statements in symbolic form. This will make it easier for them to find the logical conclusion.

**Additional Example:** Is the following argument logical? Why or why not?

Any student that likes math must have a logical mind.

Lily is logical.

Conclusion: Lily likes math.

**Solution:** Change this argument into symbols.

$$p \rightarrow q$$

$$q$$

$$\therefore p$$

If we were to combine the last statement of the argument and the conclusion, it would be  $q \rightarrow p$  or the inverse. We know that the inverse is not logically equivalent to the original statement, so this is not a logical (or valid) argument.

## Algebraic and Congruence Properties

### Goal

Students should have some familiarity with these properties. Here we can extend algebraic properties to geometric logic and congruence.

### Teaching Strategy

Use personal whiteboards to do a spot check. Write down examples of each property ( $4 + a = a + 4$ , for example) either on the board or overhead. Then have students “race” to see who writes the correct answer on their whiteboard the fastest. If you do not want to make it a competition, just have students show you the answer quickly, 2-3 seconds, and then put their whiteboard down to erase. This could also be done as a competition in groups.

Stress to students that the properties of congruence can only be used with a  $\cong$  symbol and properties of equality with an = sign. Remind students of the difference between congruence and equality that was discussed in Chapter 1.

Have students expand on the properties mentioned in this lesson. Students may come up with the multiplying fractions property, reciprocals, or cross-multiplication.

### Prove Move

This lesson introduces proofs. In this text, we will primarily use two-column proofs. Because of the nature of this text, all homework questions and assessment relating to proofs will be fill-in-the-blank. Feel free to explain the concept of a paragraph proof and flow-chart proof, if you feel it would help your students.

Proofs can be very difficult for students to understand. They might ask “why” they have to give a reason for every step. Explain that not everyone reading their proof understands math as well as they or you do. Also, apply proofs (and logical arguments) to the real world. Lawyers use logical arguments all the time. Tell them it might help them they are trying to rationalize something with their parents; a new video game, longer curfew, etc. If they have a logical, fluid “proof” to present to their parents, the parents may be more apt to agree and give them what they are asking for.

Example 4 in the text outlines the basic steps of how to start and complete a proof. Encourage students to draw their own diagrams and mark on them. The bullet list after this example should be gone over several times and addressed as you present Example 5.

### Diagrams

The best way to describe what you can and cannot assume is “looks are deceiving.” Reiterate to students that nothing can be assumed. The picture must be marked with notation such as tic marks, angle arcs, arrows, etc. in order for it to be used in a proof. If an angle looks like it is a right angle, it might not be. It needs to be explicitly stated in the Given or the angle must be marked.

**Additional Example:** Use the diagram to list everything that can be determined from the drawing and those things that cannot. For the latter list, what additional information is needed to clarify the drawing?

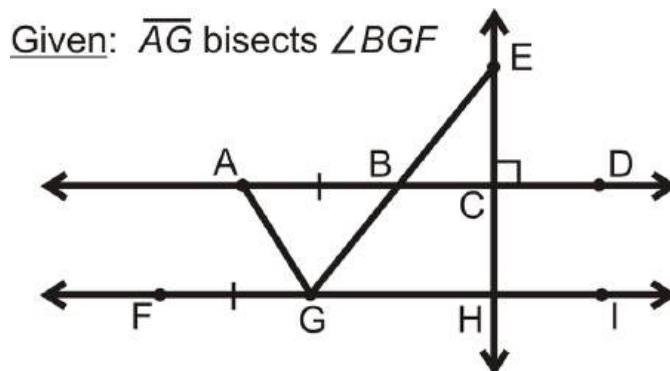

**Solution:** All vertical angles are congruent,  $AB = FG$ , and  $\overline{EH} \perp \overleftrightarrow{AD}$  are given from the markings. From the given statement, we know that  $\angle AGF \cong \angle BGA$ , which can be marked on the drawing.

Things that cannot be assumed are:  $DC = HI$ ,  $\overline{EH} \perp \overleftrightarrow{FI}$ ,  $\overleftrightarrow{AD} \parallel \overleftrightarrow{FI}$ ,  $\overline{GE}$  bisects  $\angle AGH$ ,  $GB = BE$ . To conclude that these things are true, you must be told them or it needs to be marked. (There may be more, this list will get you started)

In the above example, put the drawing on the overhead or whiteboard. After brainstorming what can and cannot be concluded from the diagram, ask students to correctly mark those things that could not be assumed true. Once they are marked by students, then the statement is validated. This example can lead into a discussion of the different ways you can interpret two perpendicular lines (lines are perpendicular, four right angles, congruent linear pairs, etc). Let students know, in this instance, they only need to be told one of these pieces of information and the others can be concluded from it.

## Proofs about Angle Pairs and Segments

### Goal

Students will become familiar with two-column proofs and be able to fill out a short proof on their own.

### Teaching Strategy

Like with the definitions of complementary and supplementary, the Same Angle Supplements Theorem and the Same Angle Complements Theorem can be confused by students. Remind them of the mnemonic in the Teaching Tips from Chapter 1 (*C* is for Complementary and Corner, *S* is for Supplementary and a Straight angle).

### Prove Move

There are several ways to approach the same proof. The order does not always matter, and sometimes different reasons can be used. For example, the Midpoint Postulate (every line segment has exactly one point that divides

it equally in half) and the Definition of a Midpoint (a point that splits a line segment equally in half) can be used interchangeably.

Students may also get stuck on the reasons. Encourage students to not worry about getting the name quite right. If they can't remember the name of a proof, tell them to write it all out. Depending on your preference, you can also let students use abbreviations for names of theorems as well. For example, the Vertical Angles Theorem can be shortened to the VA Thm. Establish these abbreviations for the entire class so there is no confusion.

In the Proof of the Vertical Angles Theorem, steps 2-4 might seem redundant to students. Explain that they need to completely explain everything they know about linear pairs.

**Additional Example:** Complete the proof by matching each statement with its corresponding reason.

Given:  $\overline{AG}$  bisects  $\angle BGF$

Prove:  $m\angle AGF = \frac{1}{2}m\angle BGF$

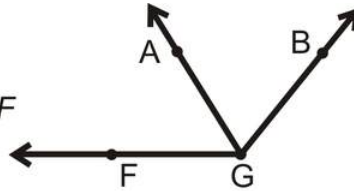

<b>Statements</b>	<b>Reasons</b>
1. $\overline{AG}$ bisects $\angle BGF$	A. <i>Distributive Property</i>
2. $\angle AGF \cong \angle AGB$	B. <i>Substitution Property of Equality</i>
3. $m\angle AGF = m\angle AGB$	C. <i>Division Property of Equality</i>
4. $m\angle BGF = m\angle AGF + m\angle AGB$	D. <i>Definition of an Angle Bisector</i>
5. $m\angle BGF = m\angle AGF + m\angle AGF$	E. <i>Given</i>
6. $m\angle BGF = 2 \cdot m\angle AGF$	F. <i>Angle Addition Postulate</i>
7. $\frac{1}{2}m\angle BGF = m\angle AGF$	G. <i>Definition of Congruent Angles</i>

**Solution:** The order of the reasons is E, D, G, F, B, A, D



## 1.3 Parallel and Perpendicular Lines

### Pacing

**TABLE 1.5:**

<b>Day 1</b> <i>Lines and Angles</i> Investigation 3-1 Investigation 3-2	<b>Day 2</b> Finish <i>Lines and Angles</i> Investigation 3-3 Start <i>Properties of Parallel Lines</i>	<b>Day 3</b> Finish <i>Properties of Parallel Lines</i> Investigation 3-4	<b>Day 4</b> <b>Quiz 1</b> Start <i>Proving Lines Parallel</i>	<b>Day 5</b> Finish <i>Proving Lines Parallel</i> Investigation 3-5
<b>Day 6</b> <i>Properties of Perpendicular Lines</i>	<b>Day 7</b> <b>Quiz 2</b> Start <i>Parallel and Perpendicular Lines in the Coordinate Plane</i>	<b>Day 8</b> Finish <i>Parallel and Perpendicular Lines in the Coordinate Plane</i>	<b>Day 9</b> <i>The Distance Formula</i>	<b>Day 10</b> <b>Quiz 3</b> Start <i>Review of Chapter 3</i>
<b>Day 11</b> <i>Review Chapter 3</i>	<b>Day 12</b> <b>Chapter 3 Test</b>	<b>Day 13</b> Finish testing (if needed) Start Chapter 4		

### Lines and Angles

#### Goal

Students will be introduced to parallel, perpendicular, and skew lines in this lesson. Transversals and the angles formed by such are also introduced.

#### Teaching Strategies

To introduce skew lines, use two pencils and hold them in the air, like skew lines. This will help students visualize that skew lines are in different planes. Use Example 1 as a jumping off point and find more parallel, skew, and perpendicular lines, other than those listed in the solution.

Investigation 3-1 is a useful tool to help students visualize the Parallel Line Postulate. You can decide whether you want to do this activity individually or teacher-led. If you decide to make it a teacher-led demonstration, consider using the overhead and folding a transparency rather than patty paper.

Explore the similarities and differences between the Parallel Line Postulate and the Perpendicular Line Postulate. You can use a Venn diagram to aid in this discussion.

Investigations 3-2 and 3-3 demonstrate the Perpendicular Line Postulate. Guide students through these constructions using a whiteboard compass. If you do not have access to a whiteboard compass, tie a piece of string around your marker and use your finger as the pointer. Make the string at least 8 inches long. If you have access to an LCD screen or computer in the classroom, the website listed in these investigations ([www.mathisfun.com](http://www.mathisfun.com)) has a great animation of these constructions.

When introducing the different angle pairs, discuss other ways that students can identify the relationships. For

example, corresponding angles are in the “same place” on lines  $l$  and  $m$ . Draw a large diagram, like the ones to the left, and find all the linear pairs, vertical angles, corresponding angles, alternate interior angles, alternate exterior angles, and same side interior angles. Use two different pictures to show the different orientations and that the lines do not have to be parallel to have these angle relationships. Explain that vertical angles and linear pairs only use two lines; however these new angle relationships require three lines to be defined. Use Examples 4 and 5. You can also expand on Example 5 and ask:

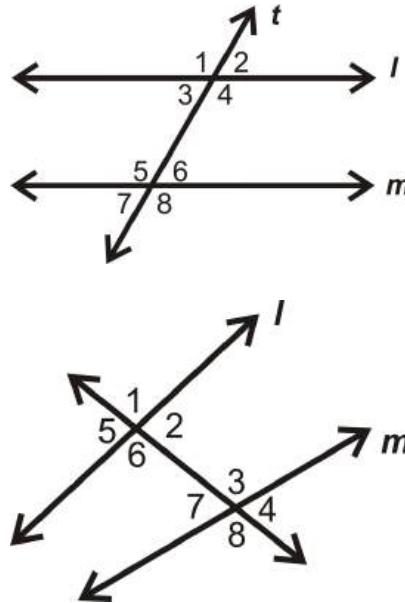

- d) What is a same side interior angle to  $\angle 6$ ? ( $\angle 7$ )
- e) What is a corresponding angle to  $\angle 8$ ? ( $\angle 6$ )
- f) What is an alternate exterior angle to  $\angle 8$ ? ( $\angle 1$ )

Students might wonder why there is no same side exterior relationship. You can explain that it does exist ( $\angle 1$  and  $\angle 4$  in the second picture), but not explicitly defined.

#### Real Life Connection

Discuss examples of parallel, skew, and perpendicular lines and planes in the real world. Examples could be: a table top and the floor (parallel planes), the legs of the table and the table top or floor (perpendicular planes), or the cables in the Brooklyn Bridge (skew lines).



### 1.3. PARALLEL AND PERPENDICULAR LINES

---

## Properties of Parallel Lines

### Goal

In this section we will extend the notion of transversals and parallel lines to illustrate the corresponding angles postulate and the alternate interior angles postulate. Additional theorems and postulates are proven in this lesson.

### Teaching Strategies

If you discuss the Know What? at the beginning of the lesson, students will only know how to find angle measures that are vertical or a linear pair with  $\angle FTS$  and  $\angle SQV$ . Revisit this at the end of the lesson and use the new-found postulates and theorems to find corresponding angles, alternate interior angles, alternate exterior angles, and same side interior angles. You could also test that the angles in  $\triangle FST$  add up to  $180^\circ$ .

Discuss Example 1 as a refresher on where the corresponding angles are and now, if the lines are parallel, which angles are congruent. Then, guide students through Investigation 3-4. If you prefer, you can do the investigation *before* introducing the Corresponding Angles Postulate and Example 1, so that students can discover this postulate on their own.

When introducing the alternate interior angles, alternate exterior angles, and same side angles use the results that the students found in Investigation 3-4. Let them draw their own conclusions about all the angles and angle measures. They already know the names of the relationships, so then ask students if any other relationships that they learned in the previous lesson are equal. This will allow you to explain the Alternate Interior Angles Theorem and Alternate Exterior Angles Theorem.

For the Same Side Interior Theorem, ask students which angles are same side interior and then ask what the relationship is. Students should notice that the two angles add up to  $180^\circ$ .

Students may notice that there are other angles that are supplementary or congruent. Encourage students to make these observations even though there are no explicit theorems.

Reinforce to students that these theorems do not apply to parallel lines. Demonstrate this by drawing two non-parallel lines and a transversal. Measure all angles. Students will see the alternate interior angles, corresponding angles, and alternate interior angles are not congruent, nor are the consecutive interior angles supplementary.

---

## Proving Lines Parallel

### Goal

The converse of the previous lesson's theorems and postulates are provided in this lesson. Students are encouraged to read through this lesson and follow along with the proofs.

### Vocabulary

Let students rewrite theorems, postulates, and properties symbolically and using pictures. The converses and the Parallel Lines Property in this section are written in this way to help students understand them better. Continue to use this strategy throughout the text.

### Teaching Strategies

Review the concept of a converse from Chapter 2. Then, introduce the converse of the Corresponding Angles Postulate and ask students if they think it is true. Investigation 3-5 is one way to show students that converse of the Corresponding Angle Postulate must be true. Remind students that Postulates do not need to be proven true. However, it is always nice to show students why.

Decide if you would like Investigation 3-5 to be student driven or teacher-led. As a teacher-led investigation, this

activity will show students that the converse of the Corresponding Angles Postulate is true. As a student driven activity, encourage students to work in pairs. Before starting, demonstrate how to copy an angle (Investigation 2-2) and then allow students to work through the investigation. Expect it to take 15 minutes.

Investigation 3-5 can also be redone such that students copy the angle and place it in the location of the alternate interior or alternate exterior angle location.

**Additional Example:** Put the reasons for the proof in the correct order.

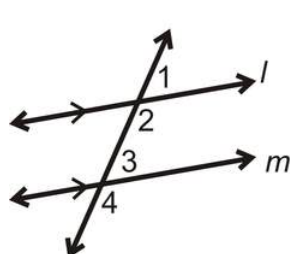

Given:  $\angle 2$  and  $\angle 3$  are supplementary.

Prove:  $l \parallel m$

Statement	Reason
1. $\angle 2$ and $\angle 3$ are supplementary.	A. Linear Pair Postulate
2. $m\angle 2 + m\angle 3 = 180^\circ$	B. Substitution Property of Equality
3. $\angle 1$ and $\angle 2$ are a linear pair.	C. Given
4. $\angle 1$ and $\angle 2$ are supplementary.	D. Definition of Congruent Angles
5. $m\angle 1 + m\angle 2 = 180^\circ$	E. Converse of the Corresponding Angles Postulate
6. $m\angle 1 = m\angle 3$	F. Definition of Supplementary Angles
7. $\angle 1 \cong \angle 3$	G. Definition of a Linear Pair
8. $l \parallel m$	H. Definition of Supplementary Angles

**Solution:** The correct order is C, F or H, G, A, F or H, B, D, E.

## Properties of Perpendicular Lines

### Goal

This section further explains the properties of perpendicular lines and how they affect transversals.

### Perpendicular Lines Investigation

On the whiteboard, draw a linear pair such that the shared side is perpendicular to the non-adjacent sides (see picture). Ask students what the angle measure of each angle is and what they add up to. Once students arrive at the correct conclusion, reiterate that a congruent linear pairs is the same as a linear pair formed by perpendicular lines and the angles will always be  $90^\circ$ .

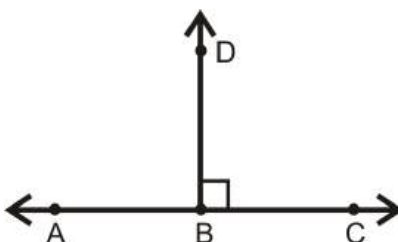

Second, extend  $\overrightarrow{BD}$  to make a line and add a parallel line to  $\overleftrightarrow{AC}$  (see picture). Now, discuss the effects of a perpendicular transversal. Steer this discussion towards Theorems 3-1 and 3-2 and see if the converses of either of these theorems are true. Again, reiterate that all eight angles in this picture will be  $90^\circ$ .

### 1.3. PARALLEL AND PERPENDICULAR LINES

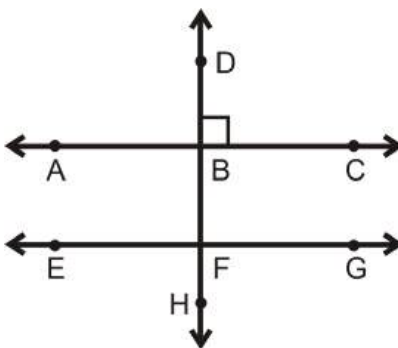

### Prove Move

In a proof involving perpendicular lines, the following three steps must be included to say that the angles are  $90^\circ$ .

- Two lines are perpendicular (usually the given)
- The angles formed are right angles (definition of perpendicular lines)
- The angles formed are  $90^\circ$  (definition of right angles)

To say that two right angles are congruent, the following steps must be included:

- Two lines are perpendicular (usually the given)
- The angles formed are right angles (definition of perpendicular lines)
- The right angles are congruent/equal (all right angles are congruent or congruent linear pairs)

This can seem repetitive to students because many of them will feel that it should be inferred that if two lines are perpendicular, then all the angles will be equal/right/ $90^\circ$ . This is not the case. Explain that they are writing a proof to someone who knows nothing about math or the definitions of perpendicular lines or right angles. They cannot assume that it is the math teacher that is reading each proof. See Example 3 in this section as an example of these steps.

**Additional Example: Algebra Connection** Solve for  $x$ .

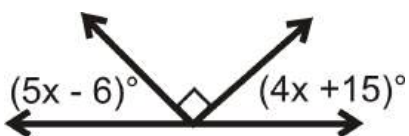

**Solution:** The three angles add up to  $180^\circ$ , or  $(5x - 6)^\circ$  and  $(4x + 15)^\circ$  add up to  $90^\circ$ .

$$\begin{aligned}(5x - 6)^\circ + (4x + 15)^\circ &= 90^\circ \\ 9x + 9^\circ &= 90^\circ \\ 9x &= 81^\circ \\ x &= 9^\circ\end{aligned}$$

---

## Parallel and Perpendicular Lines in the Coordinate Plane

### Goal

Students should feel comfortable with slopes and lines. Use this lesson as a review of key concepts needed to determine parallel and perpendicular lines in the coordinate plane. Then, we will apply the concepts learned in this chapter to the coordinate plane.

### Real Life Connection

Ask students to brainstorm the many different interpretations of the word slope. Apply these to real world situations such as the slope of a mountain, or the part of a continent draining into a particular ocean (Alaska's North Slope), the slope of a wheelchair ramp, etc. Discuss synonyms for slope: grade, slant, incline. Then, have students brainstorm further. Relate this back to the Know What? for this section. Explain how the slope and the grade are related. For example, in the Know What? the slope of the California Incline is  $\frac{3}{25}$  (see FlexBook). The grade of this incline is a percentage, so  $\frac{3}{25} \cdot 100\% = 12\%$ .

### Relevant Review

Before discussing standard form for a linear equation, make sure students can clear fractions.

**Additional Example:** Solve the following equations for  $x$ .

a)  $\frac{5}{6}x = 30$

b)  $\frac{2}{3}x + 3 = 9$

c)  $\frac{7}{6}x + \frac{1}{4} = \frac{1}{2}$

**Solution:** Multiply each number by what the lowest common denominator would be.

a)  $6 \cdot \left(\frac{5}{6}x = 30\right)$

$$5x = 180$$

$$x = 36$$

b)  $3 \cdot \left(\frac{2}{3}x + 3 = 9\right)$

$$2x + 9 = 27$$

$$2x = 18$$

$$x = 9$$

c)  $12 \cdot \left(\frac{1}{3}x + \frac{1}{4} = \frac{3}{2}\right)$

$$4x + 3 = 18$$

$$4x = 15$$

$$x = 3.75$$

Of course, there are other ways to approach these problems, but this method of clearing fractions will help students change slope-intercept form into standard form. Show students these alternate ways of solving these problems and let them decide which is easier. Then, apply both to changing a slope-intercept equation into standard form.

**Additional Example:** Change  $y = \frac{3}{4}x - \frac{1}{2}$  into standard form using two different methods.

**Solution:** Method #1: Clear fractions

$$4 \cdot \left(y = \frac{3}{4}x - \frac{1}{2}\right)$$

$$4y = 3x - 2$$

$$-3x + 4y = -2$$

$$\text{or } 3x - 4y = 2$$

Method #2: Find a common denominator

## 1.3. PARALLEL AND PERPENDICULAR LINES

$$\begin{aligned}\frac{4}{4}y &= \frac{3}{4}x - \frac{2}{4} \\ -\frac{3}{4}x + \frac{4}{4}y &= -\frac{2}{4} \\ -3x + 4y &= -2 \\ 3x - 4y &= 2\end{aligned}$$

Students generally want to avoid fractions, so Method #1 should seem for desirable to them.

### Teaching Strategies

When discussing the rise over run triangles, begin making the right triangle connection to students, demonstrating that every rise/run triangle will form a  $90^\circ$  angle. When students are asked to find the distance between two points, they can use the Pythagorean Theorem.

Have students trace the top and bottom edges of a ruler onto a coordinate plane (use graph paper). Ask students to determine the equations for each line and compare the results. Students should notice that, if done correctly, the slopes will be equal. Recall that this is an easy way to draw parallel lines (Investigation 3-4).

## The Distance Formula

### Goal

Students are introduced to the Distance Formula and its applications.

### Teaching Strategies

Students should be familiar with the Pythagorean Theorem and possibly even the Distance Formula from previous classes. A quick review of the Pythagorean Theorem might be helpful. The reason neither are derived at this time is because we have not yet introduced triangles or the properties of right triangles, which is in Chapter 9. At this point, students can accept both formulas as true and they will be proven later.

Even though the Distance Formula is written  $d = \sqrt{(x_2 - x_1)^2 + (y_2 - y_1)^2}$ , where  $(x_1, y_1)$  is the first point and  $(x_2, y_2)$  is the second point the order does not matter as long as the same point's coordinate is first. So, if students prefer, they can use  $d = \sqrt{(x_1 - x_2)^2 + (y_1 - y_2)^2}$ . Using Example 1, show students that they can use  $d = \sqrt{(x_1 - x_2)^2 + (y_1 - y_2)^2}$  and the answer will be the same.

$$d = \sqrt{(4 - (-10))^2 + (-2 - 3)^2} = \sqrt{14^2 + (-5)^2} = \sqrt{196 + 25} = \sqrt{221}$$

Finding the distance between two parallel lines can be quite complicated for some students because there are so many steps to remember. For this text, we have simplified this subsection to only use lines with a slope of 1 or -1. Reinforce the steps used to find the distance between two parallel lines from Example 5.

**Additional Example:** Find the shortest distance between  $y = x + 4$  and  $y = x - 4$ .

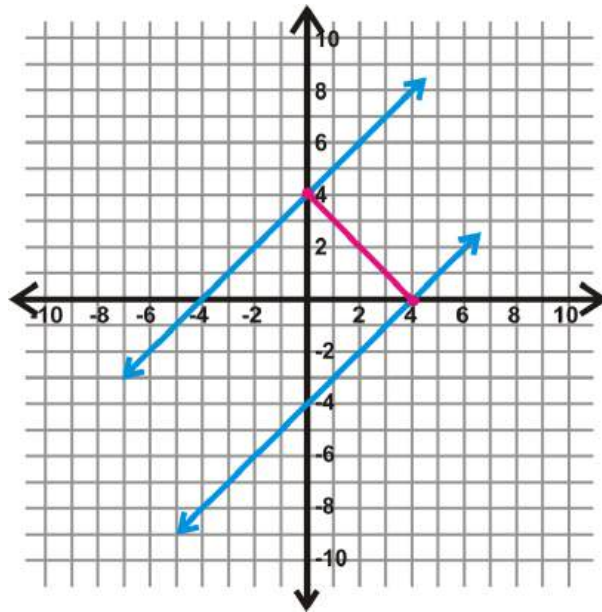

**Solution:** First, graph the two lines and find the  $y$ -intercept of the top line, which is  $(0, 4)$ .

The perpendicular slope is  $-1$ . From  $(0, 4)$  draw a straight line with a slope of  $-1$  towards  $y = x - 4$ . This perpendicular line intersects  $y = x - 4$  at  $(4, 0)$ . Use these two points to determine how far apart the lines are.

$$\begin{aligned}
 d &= \sqrt{(0 - 4)^2 + (4 - 0)^2} \\
 &= \sqrt{(-4)^2 + 4^2} = \sqrt{16 + 16} = \sqrt{32} \approx 5.66 \text{ units}
 \end{aligned}$$



## 1.4 Triangles and Congruence

### Pacing

**TABLE 1.6:**

<b>Day 1</b> <i>Triangle Sums</i> Investigation 4-1	<b>Day 2</b> <i>Congruent Figures</i>	<b>Day 3</b> <b>Quiz 1</b> Start <i>Triangle Congruence using SSS and SAS</i>	<b>Day 4</b> Finish <i>Triangle Congruence using SSS and SAS</i> Investigation 4-2 Investigation 4-3	<b>Day 5</b> <i>Triangle Congruence using ASA, AAS, and HL</i> Investigation 4-4
<b>Day 6</b> More <i>Triangle Congruence using ASA, AAS, and HL</i>	<b>Day 7</b> <b>Quiz 2</b>	<b>Day 8</b> <i>Isosceles and Equilateral Triangles</i> Investigation 4-5 Investigation 4-6	<b>Day 9</b> <b>Quiz 3</b>	<b>Day 10</b> <i>Review Chapter 4</i>
<b>Day 11</b> Finish <i>Review of Chapter 4</i>	<b>Day 12</b> <b>Chapter 4 Test</b>			

### Triangle Sums

#### Goal

First, this lesson reviews the types of triangles. The Triangle Sum Theorem will be introduced and proven followed by the Exterior Angle Theorem.

#### Notation Note

A new symbol,  $\Delta$ , is introduced to label a triangle. The order of the vertices do not matter for a triangle (unlike when labeling an angle). Usually the vertices are written in alphabetical order.

#### Teaching Strategies

To review finding angle measures, give them the six triangles at the beginning of the section and have them use their protractors to measure all the angles. Then, discuss their results. Students should notice that all the angles add up to  $180^\circ$ , all the angles in an equilateral triangle are  $60^\circ$ , and two of the angles in an isosceles triangle are equal.

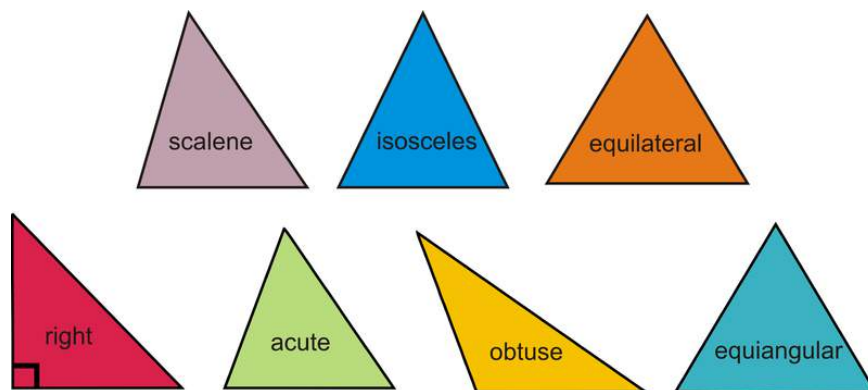

Investigation 4-1 is a version of a proof of the Triangle Sum Theorem. One approach to this investigation is to demonstrate for the students. You can do the activity on the overhead and have students discover the sum of all the angles. You may need to remind students that a straight angle is  $180^\circ$ . You could also have the students perform this investigation in pairs. After completing this investigation, go over the traditional proof in the text. Ask students how the traditional proof is similar to the investigation. This will make the traditional proof easier to understand.

Guide students through Example 5 before showing them the answer. Once all the exterior angles are found, ask students to find their sum. This will lead into the Exterior Angle Sum Theorem. Students might need a little clarification with this theorem. Explain that each *set* of exterior angles add up to  $360^\circ$ . This theorem will be addressed again in Chapter 6.

The Exterior Angle Theorem can be hard for students to remember. Present it like a shortcut. If students forget the shortcut, they can still use the Triangle Sum Theorem and the Linear Pair Postulate. See Examples 7 and 8.

## Congruent Figures

### Goal

The goal of this lesson is to prepare students for the five triangle congruency theorems and the definition of congruent triangles.

### Notation Note

Revisit congruence notation from earlier lessons. This is the first time students will apply congruence to a shape. Remind them that figures are congruent and measurements are equal. So, two triangles can be congruent and the measurements of their sides would be equal. Stress the importance of labeling each congruency statement such that the congruent vertices match.

Stress the tic mark notation in relation to the congruency statement. Simply because the letters used are in alphabetical order does not necessarily mean they will line up this way in a congruency statement. Students must follow the tic marks around the figure when writing congruency statements.

### Teaching Strategies

When writing congruence statements, have students put the first triangle's vertices in alphabetical order. Then, match up the second triangle's vertices so that the congruent angles are lined up. Remember that it is very common to use letters in alphabetical order, however they might not always line up so that the congruent triangles vertices will be in alphabetical order. For example,  $\triangle ABC$  might not be congruent to  $\triangle DEF$ , but it could be  $\triangle ABC \cong \triangle FDE$ .

Rather than needing to know all three pairs of angles and sides are congruent, the Third Angle Theorem eliminates one set of angles. Now, students need to know that two sets of angles and three sets of sides are congruent to show that two triangles are congruent. Ask students if they think there are any other shortcuts to finding out if two triangles

are congruent. Can they show that two triangles are congruent using 4 pieces of information? 3 pieces? This could be a discussion for the end of the lesson and lead into the next.

### Prove Move

In this lesson, we introduce CPCTC (corresponding parts of congruent triangles are congruent). Even though this is not a theorem, it will be used in proving that parts of triangles are congruent. CPCTC can only be used *after* two triangles are stated and proven congruent in a proof.

The Reflexive Property of Congruence is commonly used in proofs to say that a shared side or angle is congruent to itself. We will discuss this more in the next section.

## Triangle Congruence using SSS and SAS

### Goal

This lesson introduces students to the formal concept of triangle congruency through the SSS and SAS Congruence Theorems.

### Teaching Strategies

When introducing SSS Congruence Postulate let students do Investigation 4-2 individually. Walk through the classroom and assist students with the steps. Once they reach Step 5, ask if they can make another triangle with these three measurements. Every student should have a 3-4-5 right triangle and have them show each other their constructions. Have students rotate and flip their triangles, but demonstrate that they still have the same shape.

You can also use the Distance Formula to show that two triangles are congruent using SSS (Examples 5 and 6). In Example 5 the two triangles are congruent. Show students that they are in different places, flipped and rotated. Put this example on a transparency and cut out  $\triangle ABC$ . Then, place it over  $\triangle DEF$  so that they are lined up. This also shows that the two triangles are congruent.

To introduce the SAS Congruence Theorem, you can either let students do Investigation 4-3 individually or in pairs. Like with the previous investigation, as students to compare their triangles to the triangles drawn by other students in the class. Again, they will see that all the triangles have the same shape and are congruent.

The concept of an included angle can be confusing for some students. Draw triangles to show students the difference. See picture.

Reinforce that the angle must be between the two sides to be a valid congruence theorem. The way the letters are written, SAS, also should remind students that the angle is between the two sides. SSA (or ASS) implies that the angle is not between the two sides.

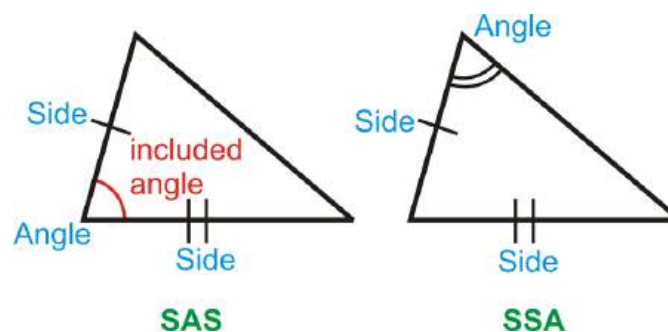

Students may ask if SSA is a valid congruence theorem; it is not. There is an explanation of this in the next section. Also, students will realize that SSA and ASS are the same thing. You can address this however you seem fit. Some teachers approach it straight on while others may choose to avoid it and refer to this combination as SSA only.

### Prove Move

When using SSS and SAS in a proof, students must present each piece as a step. For SSS, there needs to be three steps, one for each set of congruent sides. For SAS, there needs to be two steps for the two sets of congruent sides and one step for the included angles. Then, students can list the congruence statement and reason.

The Reflexive Property of Congruence can be used in triangle proofs. If two triangles share a side or an angle, the Reflexive Property is the reason this piece is congruent to itself. Students might feel as though this is an unnecessary step, but just remind them that they must right all three sets of congruent sides/angles in order to state that two triangles are congruent.

## Triangle Congruence using ASA, AAS, and HL

### Goal

Students will learn the ASA, AAS and HL Congruence Theorems and how to complete proofs using all five of the congruence theorems.

### Teaching Strategies

Investigation 4-4 should be done individually and then students can compare their triangles with the students around them. Like with Investigations 4-2 and 4-3, students should realize that no other triangle can be drawn. Rotation and reflection do not change the shape of the triangle (Chapter 12).

ASA and AAS can be hard for students to distinguish between. Draw the two theorems side by side and compare. See picture.

Here we introduce the concept of an included side. The definition of an included side is very similar to that of an included angle. Ask students to compare the differences and similarities.

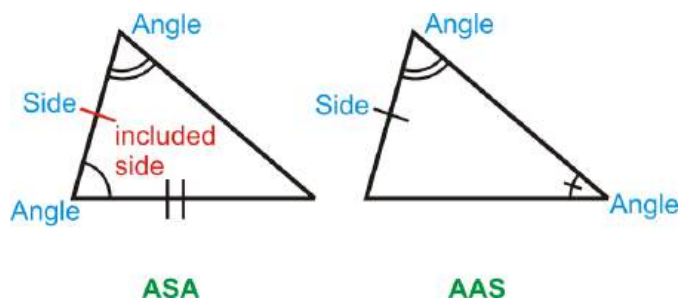

The proof of the AAS Congruence Theorem may help students better understand the difference between it and ASA. Explain that because of the Third Angle Theorem, AAS is also a congruence theorem. Example 3 shows which sides or angles are needed to show that the same two triangles are congruent using SAS, ASA, and AAS. Go over this example thoroughly with students.

Hypotenuse-Leg (HL) is the only congruence theorem that is triangle-specific. This theorem can only be used with right triangles. So, in order to use this congruence theorem in a proof, the student must know that the two triangles are right triangles (or be able to show it in the proof).

AAA and SSA are introduced at the end of the section as the other possible side-angle relationships that we have yet to explore. Neither of these relationships can prove that two triangles are congruent, but it is useful to show students why they do not work. AAA shows that two triangles are similar, as in Chapter 7 and SSA can actually create two different triangles.

Have students copy the Recap Chart into their notes. This chart will be a very helpful study guide for the chapter test.

Example 7 is the only example that touches on CPCTC, even though there are proofs that use it in the homework. Explain to students that they can only use CPCTC after they have proven two triangles are congruent.

This is a very challenging lesson for students. If you feel as though not everyone is grasping the concept of proofs or all the different triangle congruence theorems, slow down and go back over this lesson.

**Additional Example:** Put the reasons to the proof below in the correct order.

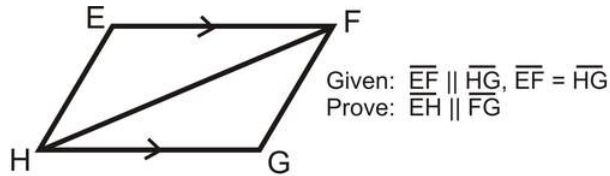

Given:  $\overline{EF} \parallel \overline{HG}$ ,  $\overline{EF} = \overline{HG}$   
 Prove:  $\overline{EH} \parallel \overline{FG}$

Statement	Reason
1. $\overline{EF} \parallel \overline{HG}$	A. CPCTC
2. $\angle FHG \cong \angle EFH$	B. Given
3. $\overline{EF} \cong \overline{HG}$	C. Given
4. $\overline{HF} \cong \overline{HF}$	D. Alternate Interior Angles Theorem
5. $\triangle EFH \cong \triangle GHF$	E. Converse of the Alternate Interior Angles Theorem
6. $\angle EHF \cong \angle FGH$	F. SAS Congruence Theorem
7. $\overline{EH} \parallel \overline{FG}$	G. Reflexive Property of Congruence

**Solution:** The correct order is B, D, C, G, F, A, E

## Isosceles and Equilateral Triangles

### Goal

This lesson illustrates the special properties that arise from isosceles and equilateral triangles.

### Teaching Strategies

Investigation 4-5 can be done individually or teacher-led. As a teacher-led activity, this investigation should be done as a group discovery. You should ask questions of the students to keep them engaged while you are performing the construction (on the overhead or whiteboard). Then use a protractor to measure the angles. Or, you could have a student come up and measure the angles. Ask them to generalize this construction into the Base Angles Theorem.

This investigation also leads into the Isosceles Triangle Theorem. Have students duplicate  $\triangle DEF$  (just before Example 1) in their notes. They should write down all markings and all corresponding congruence statements (for angles and sides) and any perpendicular statements. Stress that this theorem is only true at the vertex angle.

Investigation 4-6 can also be done individually or teacher-led. This investigation allows students to come to their own conclusion about equilateral triangles. They should discover that an equilateral triangle is also an equiangular triangle in Step 4.

**Additional Example: Algebra Connection** Solve for  $x$  and  $y$ .

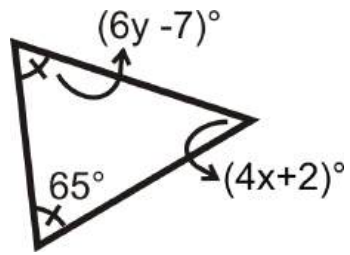

**Solution:** It does not matter which variable you solve for first.

$$(6y - 7)^\circ = 65^\circ$$

$$6y = 72^\circ$$

$$y = 12^\circ$$

$$(4x + 2)^\circ + 65^\circ + 65^\circ = 180^\circ$$

$$4x + 132^\circ = 180^\circ$$

$$4x = 48^\circ$$

$$x = 12^\circ$$

## 1.5 Relationships with Triangles

### Pacing

TABLE 1.7:

<b>Day 1</b> <i>Midsegments</i>	<b>Day 2</b> Start <i>Perpendicular Bisectors and Angle Bisectors in Triangles</i> Investigation 5-1 Investigation 5-2	<b>Day 3</b> Finish <i>Perpendicular Bisectors and Angle Bisectors in Triangles</i> Investigation 5-3 Investigation 5-4	<b>Day 4</b> <b>Quiz 1</b> Start <i>Medians and Altitudes in Triangles</i> Investigation 5-5	<b>Day 5</b> Finish <i>Medians and Altitudes in Triangles</i> Investigation 5-6
<b>Day 6</b> <i>Inequalities in Triangles</i>	<b>Day 7</b> <b>Quiz 2</b> *Start <i>Extension: Indirect Proof</i>	<b>Day 8</b> *Finish <i>Extension: Indirect Proof</i>	<b>Day 9</b> * <b>Quiz 3</b>	<b>Day 10</b> <i>Review Chapter 5</i>
<b>Day 11</b> <i>Review Chapter 5</i>	<b>Day 12</b> <b>Chapter 5 Test</b>	<b>Day 13</b> Finish <b>Chapter 5 Test</b> (if needed) Start Chapter 6		

### Midsegments

#### Goal

This lesson introduces students to midsegments and the properties they hold.

#### Vocabulary

This lesson begins a chapter that is full of vocabulary and new types of line segments. As a new line segment is learned, have students write each one with its definition and a picture in a self-made table. By the end of this chapter, students should have: midsegment, perpendicular bisector, angle bisector, median, and altitude. You can also have students draw these line segments in acute, right and obtuse triangles. Make sure to include the appropriate labeling and congruence statements for each line segment within each triangle as well.

#### Notation Note

Review with students the difference between a line segment,  $\overline{NM}$  and its distance  $NM$ . These notations will be used frequently in this chapter.

#### Teaching Strategies

Stress the properties of midsegments to students and make sure they understand the definition of a midsegment before moving on to the next section. Each segment in a triangle is very similar, so students tend to get them mixed up. A midsegment is unique because it connects two midpoints.

Examples 3-5 investigate the properties of a midsegment in the coordinate plane. Give students these examples without the solutions and have them work in pairs to arrive at the Midsegment Theorem on their own. At the completion of Example 5, ask students if they notice any similarities between the slopes of  $\overline{NM}$  and  $\overline{QO}$  and the

lengths of  $NM$  and  $QO$ . Explain that their findings are the Midpoint Theorem.

Discuss that a midsegment is both parallel and half the length of the third side. Stress to students that if a line is parallel to a side in a triangle that does not make it a midsegment. The parallel line must also connect the midpoints, pass through the midpoints, or cut the sides it passes through in half. Go over all of these different ways to state what a midpoint and midsegment are.

If you have access to an LCD display screen (in the classroom) or a computer lab, use the website <http://www.mathopenref.com/trianglemidsegment.html> (in the FlexBook) to play with midsegments within a triangle. It is a great resource to help students to better understand the Midsegment Theorem.

**Additional Example:**  $B, D, F$ , and  $H$  are midpoints of  $\triangle ACG$  and  $\triangle CGE$ .  $BH = 10$  Find  $CG$  and  $DF$ .

**Solution:**  $\overline{BH}$  is the midsegment of  $\triangle ACG$  that is parallel to  $\overline{CG}$ .  $\overline{DF}$  is the midsegment of  $\triangle CGE$  that is parallel to  $\overline{CG}$ . Therefore,  $BH = DF = 10$  and  $CG = 2 \cdot 10 = 20$ .

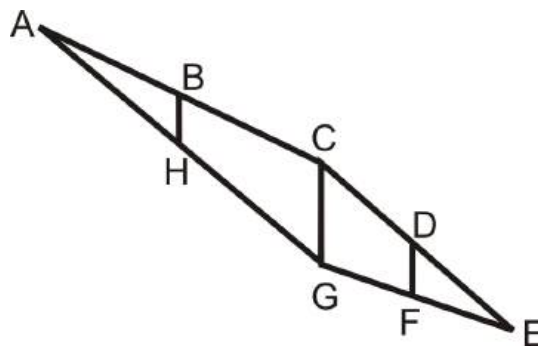

## Perpendicular Bisectors and Angle Bisectors in Triangles

### Goal

Students will apply perpendicular bisectors and angle bisectors to triangles and investigate their properties.

### Teaching Strategies

Review the constructions of a perpendicular bisector and angle bisector (Review Queue #1 and #2). When going over #3a ask students if the line that bisects the line segment is a perpendicular bisector (it is not, it is just a segment bisector). Explain that the markings must look like the ones in #4 to be a perpendicular bisector.

Investigation 5-1 guides students through the properties of a perpendicular bisector before placing it in a triangle. Show students that  $\triangle ACB$  is an isosceles triangle (in the description of the Perpendicular Bisector Theorem) which reinforces the fact that  $C$  is equidistant from the endpoints of  $\overline{AB}$ . Explain the difference between the Perpendicular Bisector Theorem and its converse. You can also have the students put the theorems into a biconditional statement.

Investigation 5-2 places the perpendicular bisectors in a triangle. This activity should be done individually, while you show students what to do. You will need to circle around the classroom to make sure students understand step 2. Then, students should be able to do step 3 on their own. Do step 4 as a class to make sure that every student understands that the circle drawn will pass through every vertex of the triangle.

Here, two new words are introduced: circumscribe and inscribe. If students have hard time remembering their definitions use their Latin roots. Circum = around and In = inside or interior. Scribe = draw or write.

The angle bisectors are also first introduced with one angle. Investigation 5-3 explores the property of one angle bisector and its relationship to the sides of the angle. This activity should be teacher-led while students are encouraged to follow along. In step 2, the folded line does not have to be a perpendicular bisector, but just a perpendicular line through  $D$ .

### 1.5. RELATIONSHIPS WITH TRIANGLES



After Investigation 5-3 compare the properties of an angle bisector and a perpendicular bisector. Draw them next to each other with markings and draw a Venn diagram with the similarities and differences. *If this lesson takes more than one day, this could be a good warm-up.*

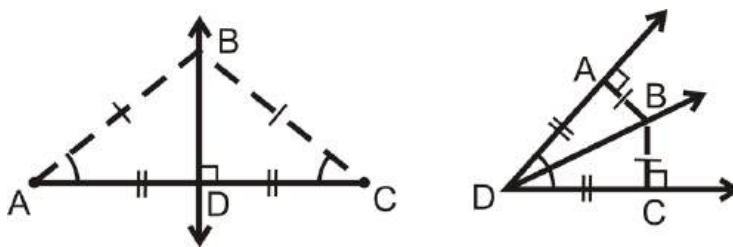

After analyzing the pictures, lead students towards the conclusion that  $B$  is *equidistant from the endpoints* of  $\overline{AC}$  (in picture 1) and  $B$  is *equidistant from the sides* of  $\angle ADC$ . Then, to translate a perpendicular bisector into a triangle, the point where they all intersect would be equidistant from the endpoints of all the line segments, which are the vertices of the triangle. The point of intersection of the angle bisectors would be equidistant from all the sides of the angles which are also the sides of the triangle.

Just like with Investigation 5-2, lead students through this activity. Make sure every student understands how to fold the patty paper to create an angle bisector (step 2). Once they make all the angle bisectors, do step 4 together to ensure that every student understands that the circle will pass through the sides of the circle.

Students can get the properties of perpendicular bisectors and angle bisectors within triangles confused. One way to help students remember which is which show them that the point of intersection of the perpendicular bisectors can be outside the triangle so the circle would go around the outside the circle (circumscribe). The point of intersection of the angle bisectors is always inside the triangle so the circle will always be inside the triangles (inscribed).

*The points of concurrency of the perpendicular bisectors, angle bisectors and altitudes were intentionally left out of the Basic Geometry FlexBook to avoid confusion and to encourage students to focus on the theorems and properties of these lines. The Enrichment Teacher's Edition FlexBook discusses the names of these points of concurrency if you would like to include them in your curriculum.*

---

## Medians and Altitudes in Triangles

### Goal

Students will be introduced to medians and their point of intersection, the centroid. They will explore the properties of a centroid as well as learn how to construct an altitude.

### Teaching Strategies

The median is now the third segment that passes through at least one midpoint. Make sure students understand the difference between a median, midsegment and a perpendicular bisector. Also, students may get the angle bisector confused with a median because sometimes it “looks like” (a fatal flaw in geometry) the angle bisector will pass through the opposite side’s midpoint. Students can never assume from a picture that the angle bisector and a median are the same. Discuss the cases when they are the same, this may alleviate some confusion. When a triangle is an isosceles triangle, the line segments are all the same when drawn from the vertex. Also when a triangle is equilateral, the line segments are all the same regardless of which vertex they are drawn from. The following picture might better illustrate this point:

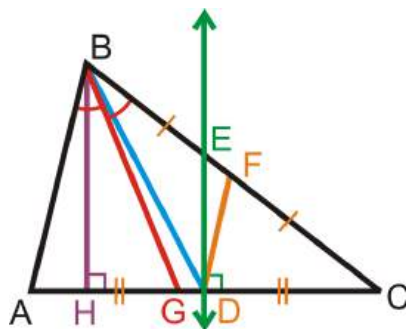

Points  $F$  and  $D$  are the midpoints of the sides they are on.

$\overline{FD}$  is a midsegment

$\overline{ED}$  is a perpendicular bisector

$\overline{BG}$  is an angle bisector

$\overline{BD}$  is a median

$\overline{BH}$  is an altitude

With Investigation 5-6, encourage students to construct more than one altitude on the given obtuse triangle. While we did not explore the point of intersection for the altitudes, there is one. Have students arrive at this conclusion on their own, while constructing the other altitudes in  $\triangle ABC$ . While students are performing the constructions, encourage them to turn their paper around so that the side they are making the altitude perpendicular to is horizontal. This will make the process easier.

At the end of this lesson, compare all of the line segments within triangles. Use the table below. The answers are filled in, but draw on the board without answers and generate the answers as a class. You can also use the picture above to help students determine the properties of the line segments.

**TABLE 1.8:**

	Pass through the midpoint(s)?	Pass through a vertex?	Perpendicular?	Properties of the point of intersection
<i>Midsegment</i>	Yes, two.	No	No	No point of intersection
<i>Angle Bisector</i>	No	Yes	No	Equidistant from the sides of a triangle; inscribed circle.
<i>Perpendicular Bisector</i>	Yes	No	Yes	Equidistant from the vertices of a triangle; circumscribed circle.
<i>Median</i>	Yes	Yes	No	The centroid; the “center of gravity” of a triangle. Also it splits the medians into $\frac{2}{3} - \frac{1}{3}$ pieces.
<i>Altitude</i>	No	Yes	Yes	None

Check and recheck that students understand these five line segments before moving on. It is very common for students to get the definitions and properties confused.

### 1.5. RELATIONSHIPS WITH TRIANGLES

---

## Inequalities in Triangles

### Goal

The purpose of this lesson is to familiarize students with the angle inequality theorems and the Triangle Inequality Theorem and the SAS and SSS Inequality Theorems.

### Teaching Strategies

Students have probably figured out the Triangle Inequality Theorem but not actually put it into words. Ask the class if they can make a triangle out of the lengths 3 in, 5 in, and 9 in. You can give each student a few pieces of dry spaghetti and have them break the pieces so that they are the lengths above and then attempt to make a physical model. They will discover that it is impossible. Then, tell the class to break off 1 in of the 9 in piece and try again. Again, this will not work. Finally, tell them to break off another  $\frac{1}{2}$ -inch and try a third time. This time it will work. Analyze each set of numbers. You could also have students do this a fourth time and make the longest piece either 6 or 7 inches. They will still be able to make a triangle.

3, 5, 9 → No triangle

3, 5, 8 → No triangle

3, 5, 7.5 → Yes!

3, 5, 6 → Yes!

Guide students towards the Triangle Inequality Theorem. Example 4 explores the possible range of the third side, given two sides. Explain to students that this third side can be the shortest side, the longest side or somewhere in-between. We have no idea, so we have to propose a range of lengths that the third side could be. Have students shout out possible lengths of the third side and place them in a table. Then, show them the way to write the lengths as a compound inequality.

Example 4 leads students into the SAS Inequality Theorem, which compares two triangles where two sides are the same length and the included angles are different measurements. We know, from Chapter 4, that if the included angles are congruent, then the triangles would be congruent, but in this case, we know that one is bigger than the other. Logically, it follows that the triangle with the bigger included angle will have the longer opposite side. This is a very wordy theorem; it might help to explain using the symbols and picture in the text. *This theorem is also called the Hinge Theorem.*

The SSS Inequality Theorem is the converse of the SAS Inequality Theorem. Now we know that two sides are congruent and the third sides are not. It follows that the angle opposite the longer side is going to be larger than the same angle in the other triangle. Example 6 is a good example of how this theorem works. You can also reverse the question and ask: If  $m\angle 1 > m\angle 2$ , what can we say about  $XY$  and  $XZ$ ?

---

## Extension: Indirect Proof

### Goal

Students should be able to understand how an indirect proof is organized and executed.

### Teaching Strategy

An indirect proof is a powerful reasoning tool that students might find useful outside of mathematics. Ask students what professions they think would use indirect proofs (also called proof by contradiction). Examples are lawyers (disproving innocence/guilt), doctors (disproving diagnosis), crime scene investigators (collecting evidence and trying to prove or disprove).

**Additional Example:** Prove  $\sqrt{15} \neq 4$ .

**Solution:** Assume  $\sqrt{15} = 4$

Squaring both sides, we get  $15 = 16$ .

But  $15 \neq 16$ , therefore,  $\sqrt{15} \neq 4$ .

## 1.6 Polygons and Quadrilaterals

### Pacing

TABLE 1.9:

<b>Day 1</b> <i>Angles in Polygons</i> Investigation 6-1 Investigation 6-2	<b>Day 2</b> <i>Properties of Parallelograms</i> Investigation 6-3	<b>Day 3</b> <b>Quiz 1</b> Start <i>Proving Quadrilaterals are Parallelograms</i>	<b>Day 4</b> Finish <i>Proving Quadrilaterals are Parallelograms</i>	<b>Day 5</b> <i>Rectangles, Rhombuses, and Squares</i> Investigation 6-4 Investigation 6-5
<b>Day 6</b> <b>Quiz 2</b> Start <i>Trapezoids and Kites</i>	<b>Day 7</b> Finish <i>Trapezoids and Kites</i> Investigation 6-6	<b>Day 8</b> <b>Quiz 3</b> Start <i>Review of Chapter 6</i>	<b>Day 9</b> Finish <i>Review of Chapter 6</i>	<b>Day 10</b> <b>Chapter 6 Test</b>

### Angles in Polygons

#### Goal

Students will use the Triangle Sum Theorem to derive the Polygonal Sum Theorem by dividing a convex polygon into triangles. Students will also be reintroduced to the Exterior Angle Sum Theorem, but now it will be applied to any polygon.

#### Teaching Strategies

Using the Know What? at the beginning of this lesson, discuss where someone might see polygons in nature and the real world. Determine if any of these polygons are regular polygons or not. Students might need a review of the definition of a regular polygon.

Investigation 6-1 is intended to be a student-driven activity while the teacher monitors and leads or answers questions. Students should know what a quadrilateral, pentagon, and hexagon are from Chapter 1; however they may need a little review. Diagonals were also addressed in Chapter 1. Make sure that students only draw the diagonals in step 2 from one vertex so that none of the triangles overlap. In step 3 it might be helpful to write out the last column as a list, including the triangle;  $180^\circ$ ,  $360^\circ$ ,  $540^\circ$ ,  $720^\circ$ . Then, ask students what the next number in the pattern should be. Continue this for a few more terms and then generalize into the Polygon Sum Formula.

Students might think that the Polygon Sum Formula and the Equiangular Polygon Formula are two different formulas for them to memorize. This is not the case. Tell students that they need to memorize the Polygon Sum Formula and then the Equiangular Polygon Formula simply divides the Polygon Sum Formula by the number of angles in the polygon. Stress to students that the Equiangular Polygon Formula can be used on equiangular polygons as well as regular polygons.

To introduce exterior angles for polygons, draw a triangle with its exterior angles. Students should remember that each set of exterior angles of a triangle add up to  $360^\circ$ . Then, show students the exterior angles for a square. Each exterior angle is  $90^\circ$ , so their sum would be  $360^\circ$  as well. Now, have students complete Investigation 6-2 in pairs.

The first question in the review questions is a table with angle sums and individual angles in a regular n-gon. Complete this table at the end of the lesson so that students see the relationship between all the angles and their sums. If you would like, add a final column labeled “Each exterior angle in a regular n-gon.” Students can either use

linear pairs with column 4 or divide  $360^\circ$  by the number of sides.

## Properties of Parallelograms

### Goal

The purpose of this lesson is to familiarize students with properties special to parallelograms.

### Notation Note

The notation for any quadrilateral is the list of vertices, usually clockwise, such as  $ABCD$  (quadrilateral) or  $LMNOP$  (pentagon). Students can start at any vertex they would like. The only requirement is that the vertices are listed such that they are next to each other in the picture. Quadrilateral  $ABCD$  could be:

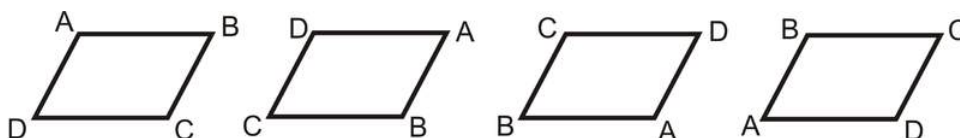

Notice that the first vertex listed and the last vertex listed are next to each other.

### Teaching Strategies

Investigation 6-3 enables students to discover the properties of parallelograms on their own. Encourage students to label the vertices of the parallelogram ( $ABCD$ , for example) and then they can write equality/congruence statements for the angles and sides. Once they have all the equality/congruence statements written (step 3), have students write down all their conclusions and see if they can generate the parallelogram theorems on their own.

Students might wonder if there is a difference between consecutive angles and same side interior angles. Discuss this with your students. One could argue they are the same. Another could argue they are different because consecutive refers to two angles that are next to each other in a polygon. Same side interior angles refer to two angles that are formed by parallel lines and one transversal.

Encourage students to make as many connections as possible. For example, students have learned parallel lines are equidistant from each other. Make this connection to a parallelogram. If students draw in the diagonals of a parallelogram; review that alternate interior angles are congruent.

In Example 3, we place the parallelogram in a coordinate plane. In this chapter we will show that certain quadrilaterals are parallelograms (and rhombuses, squares, and rectangles) when they are in the coordinate plane. In this section we introduce one method. Because the diagonals of a parallelogram bisect each other, their point of intersection should be the midpoint of each. Therefore, the midpoint of each diagonal will be the same point.

## Proving Quadrilaterals are Parallelograms

### Goal

Students will use triangle congruence postulates and theorems to prove quadrilaterals are parallelograms. Students will also determine if a quadrilateral is a parallelogram when placed in the coordinate plane.

### Teaching Strategies

There are two main ways to prove that a quadrilateral is a parallelogram: formal proof and using the coordinate plane. If students are given a formal proof, they must prove that the two halves of a parallelogram (split by one of

the diagonals) are congruent and then use of the converses used in this lesson. They will also have to use CPCTC somehow.

If students are doing a problem with a quadrilateral in the coordinate plane, then they must use the distance formula, slope formula, or midpoint formula. The distance formula would lend itself to the Opposite Sides Theorem Converse, and finding the slopes of all four sides is the definition of a parallelogram and the midpoint formula is the Parallelogram Diagonals Theorem Converse. Discuss all these options with students before allowing them to start class work or homework.

As a way to introduce the proof of the Opposite Sides Theorem Converse and the proof of Theorem 6-10 (Example 1), you can copy these theorems and then cut up the statements and reasons and put them in an envelope. Given an envelope to either pairs or groups of students and have them match up the statements with the corresponding reasons and put them in the correct order. On one side of the envelope, put the Given and Prove as well as the picture. This technique can be done for any proof.

---

## Rectangles, Rhombuses and Squares

### Goal

This lesson introduces rectangles, rhombuses, and squares. These are more specific types of parallelograms.

### Teaching Strategies

Make sure students understand that everything that falls within a rhombus possess the same characteristics and properties of a parallelogram. A rectangle also has all the properties of a parallelogram as well as its properties. A square has all the properties of a rhombus, rectangle and parallelogram. Squares do not have any of its own unique properties.

Investigation 6-4 shows us that the diagonals of a rectangle are congruent. So, if the diagonals of a parallelogram are congruent, then the parallelogram is a rectangle. Investigation 6-5 explores the properties of the diagonals of a rhombus. Here, the diagonals are perpendicular and they bisect each angle in the rhombus. Note that students do not need to show both to be a rhombus. However, if they decide to use Theorem 6-16, they do need to show that the diagonals bisect all four angles of the rhombus. Therefore, it is much easier for students to use Theorem 6-15 (showing that the diagonals are perpendicular) to show a parallelogram is a rhombus.

Because there are no theorems regarding squares, make sure you go over Example 4 thoroughly. This is the only place we discuss all the properties of squares. Stress that a square holds all the properties of a parallelogram, rectangle, and rhombus. Ask students if they think it has any of its own properties. A square is a specific version of a rhombus, so the angles are bisected. Because a square is also a rectangle, the angles are all  $90^\circ$ , so the bisected angles are all  $45^\circ$ . In addition to the properties listed in Example 4, show students other ways to write some of these properties. For example, a rectangle has four congruent angles. Students can also write this as the sides are all perpendicular to each other.

At this point, students might have the different types of parallelograms confused. There are a lot of different properties and students might have them all mixed up in their heads. One way to help is to draw a hierarchy diagram with QUADRILATERALS at the top and then two arrows. One points to PARALLELOGRAMS and the other points to OTHER TYPES. Then, ask students if they can determine how rectangles, squares, and rhombuses fit into this diagram. The final diagram should look like:

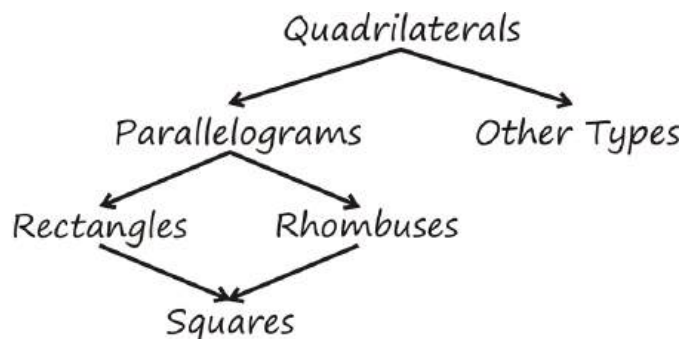

Students can add to this diagram in the next lesson.

The steps after Example 5 are very helpful for students to determine if a parallelogram is a rectangle, rhombus or square. Here is an additional example, using these steps.

**Additional Example:** The vertices of  $WXYZ$  are below. Determine the type of quadrilateral it is.

**Solution:** Let's follow the steps.

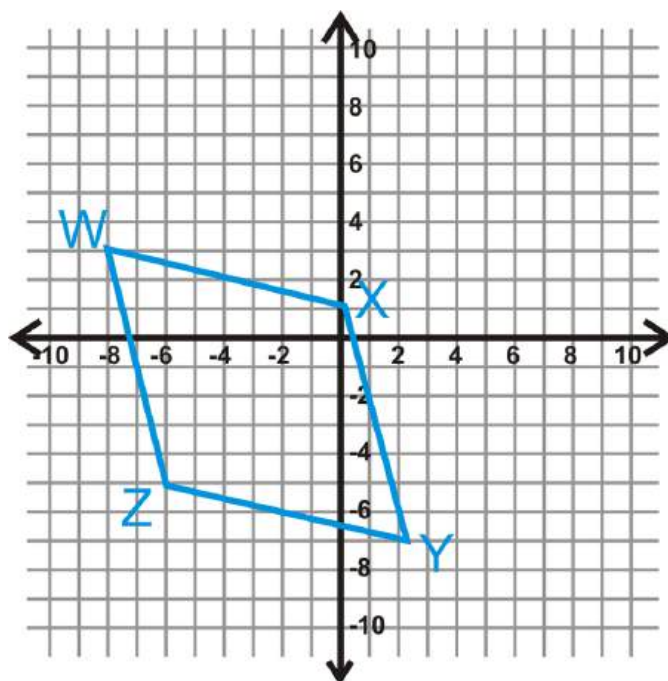

1. The quadrilateral is graphed.
2. Do the diagonals bisect each other?

$$\text{midpoint}_{WY} = \left( \frac{-8+2}{2}, \frac{3-7}{2} \right) = (-3, -2)$$

$$\text{midpoint}_{XZ} = \left( \frac{0-6}{2}, \frac{1-5}{2} \right) = (-3, -2)$$

The diagonals bisect each other. This is a parallelogram.

3. Are the diagonals equal?



$$WY = \sqrt{(-8-2)^2 + (3-(-7))^2} = \sqrt{10^2 + 10^2} = \sqrt{200}$$

$$XZ = \sqrt{(0-(-6))^2 + (1-(-5))^2} = \sqrt{6^2 + 6^2} = \sqrt{72}$$

The diagonals are not equal. This is not a rectangle.

4. At this step, we know this figure is a rhombus. It cannot be a square because the diagonals are not equal, from step 3. So, to prove that it is a rhombus, we can either show that all the sides are equal or that the diagonals are perpendicular. It is easier to find the slopes of the diagonals than do the distance formula four times.

$$m_{WY} = \frac{3-(-7)}{-8-2} = \frac{10}{-10} = -1$$

$$m_{XZ} = \frac{1-(-5)}{0-(-6)} = \frac{6}{6} = 1$$

The diagonals are perpendicular, so this reaffirms our earlier conclusion that  $WXYZ$  is a rhombus.

## Trapezoids and Kites

### Goal

This lesson introduces students to the special properties of kites, trapezoids, and isosceles trapezoids.

### Teaching Strategies

After going over the definition of a trapezoid, discuss the difference between a trapezoid and a parallelogram. Students need to realize that a trapezoid has exactly one pair of parallel sides. It is not like the definition of an isosceles triangle (at least two congruent angles). Therefore, a parallelogram is not a trapezoid.

For a trapezoid to be isosceles, the non-parallel sides must be congruent. Describe an isosceles trapezoid as cutting off the top of an isosceles triangle. Therefore, Theorem 6-17 is a form of the Base Angles Theorem for isosceles triangles. Isosceles trapezoids also have congruent diagonals, like a rectangle. Ask students if isosceles trapezoids are rectangles. This is a great example of two different quadrilaterals that have the same property. Of course, rectangles are not isosceles trapezoids because rectangles have four congruent angles and two sets of parallel sides.

Just like triangles, a trapezoid also has a midsegment. Trapezoids only have one midsegment because it connects the non-parallel sides. For this reason, the midsegment is also parallel with the parallel sides. Stress that the length of the midsegment is the average of the lengths of the parallel sides. You could also say that the midsegment is halfway between the parallel sides, so its length is halfway between the lengths of the parallel sides.

Kites are very similar to rhombuses, but a rhombus is not a kite. The definition of a kite says “a quadrilateral with two sets of adjacent congruent sides.” All sides are congruent in a rhombus. Because a kite has two sets of congruent adjacent sides, it has some properties of rhombuses. Go over the similarities and differences between kites and rhombuses. At the end of this lesson, complete the hierarchy diagram that was started in the previous lesson.

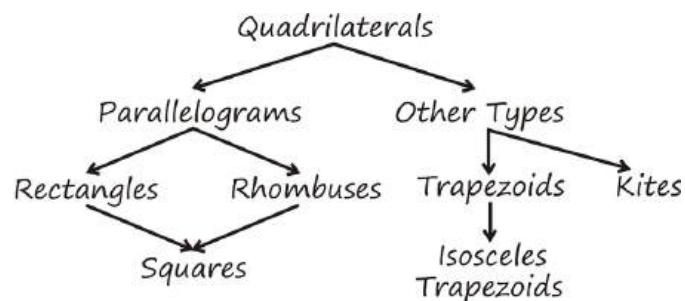

**Review Game**

Have your students create flashcards with quadrilateral names on one side and important information or properties on the reverse. Have various types of quadrilaterals, both abstract and real world, ready to show students. Once students believe they have classified the quadrilateral, they are to hold up the appropriate name. Have students do this in pairs and keep score. You can give the winners bonus points on the test, candy, or a homework pass.

## 1.7 Similarity

### Pacing

**TABLE 1.10:**

<b>Day 1</b> <i>Ratios &amp; Proportions</i>	<b>Day 2</b> <i>Similar Polygons</i>	<b>Day 3</b> <b>Quiz 1</b> Start <i>Similarity by AA</i>	<b>Day 4</b> Finish <i>Similarity by AA</i> Investigation 7-1	<b>Day 5</b> <i>Similarity by SSS and SAS</i> Investigation 7-2
<b>Day 6</b> Finish <i>Similarity by SSS and SAS</i> Investigation 7-3	<b>Day 7</b> <b>Quiz 2</b> Start <i>Proportionality Relationships</i>	<b>Day 8</b> Finish <i>Proportionality Relationships</i>	<b>Day 9</b> <i>Similarity Transformations</i>	<b>Day 10</b> <b>Quiz 3</b> <i>*Extension: Self-Similarity</i>
<b>Day 11</b> <i>*Finish Extension: Self-Similarity</i> Start <i>Review of Chapter 7</i>	<b>Day 12</b> <b>*Extension Quiz</b> <i>More Review of Chapter 7</i>	<b>Day 13</b> Finish <i>Review of Chapter 7</i>	<b>Day 14</b> <b>Chapter 7 Test</b>	<b>Day 15</b> <b>Start Chapter 8</b>

*\*Without the Extension lesson, this chapter will take 12-13 days.*

## Ratios and Proportions

### Goal

The purpose of this lesson is to reinforce the algebraic concept of ratios and proportions. Proportions are necessary when discussing similarity of geometric objects.

### Teaching Strategies

The Know What? for this lesson is a little different than the ones in previous lessons. Have students take this activity one step further and apply the concept of a scale drawing to their own room. Students can draw scale representations of their rooms (or even their whole house) and the furniture for an alternative assessment or a chapter project.

Ratios can be written three different ways. This text primarily uses fractions or the colon notation. Remind students that a ratio has no units and can be reduced just like a fraction. With rates, to contrast to with ratios, there are units. Rates are also fractions. Have students compare the similarities and differences between ratios and rates. Ask them to brainstorm types of ratios and rates.

Proportions are two ratios that are set equal to each other. The most common way to solve a proportion is cross-multiplication. Show students the proof of the Cross-Multiplication Theorem in the FlexBook. This proof makes the denominators the same, so that the numerators can be set equal to each other. Students can go through this whole process each time or they can use cross-multiplication, which can be considered a shortcut.

All of the corollaries in this lesson are considered the same as  $\frac{a}{b} = \frac{c}{d}$  because when cross-multiplied you would end up with  $ad = bc$ . Therefore, the placement of the  $a, b, c$ , and  $d$  is important. When in doubt about if two proportions are the same, always have students cross-multiply.

Corollaries 7-4 and 7-5 are a little different from the previous three. To show that these proportions are true, it might be helpful for students to see the proofs. Each corollary is proven true when the last step is  $ad = bc$  because this is the same as the cross-multiplication of  $\frac{a}{b} = \frac{c}{d}$ .

***Proof of Corollary 7-4***

$$\begin{aligned}\frac{a+b}{b} &= \frac{c+d}{d} \\ d(a+b) &= b(c+d) \\ ad+bd &= bc+bd \\ ad &= bc\end{aligned}$$

***Proof of Corollary 7-5***

$$\begin{aligned}\frac{a-b}{b} &= \frac{c-d}{d} \\ d(a-b) &= b(c-d) \\ ad-bd &= bc-bd \\ ad &= bc\end{aligned}$$

Brainstorm other possible reconfigurations of  $\frac{a}{b} = \frac{c}{d}$  with students to see if there are any other possible “corollaries.” Have students cross-multiply their “true” proportions to check to see if they are valid.

## Similar Polygons

### Goal

This lesson connects the properties of proportions to similar polygons. An introduction to scale factors is also presented within this lesson.

### Teaching Strategies

To see if students understand the definition of similar polygons, have students come up to the front board and draw pictures of two similar polygons or two non-similar polygons. You could also do this several times, before you give students the formal definition, and then students can generate one as a class.

After doing Examples 1 and 2, brainstorm with the class as to which specific types of triangles, quadrilaterals or polygons are always similar. For example, the text cites equilateral triangles and squares. This leads to the fact that all regular polygons are similar. Explore why just equilateral (rhombuses) or equiangular (rectangles) polygons are not always similar.

Students might wonder which value goes on top when finding the scale factor. Remind students that the scale factor is a ratio. In Example 4, it says “ $\triangle ABC$  to  $\triangle XYZ$ .” This is a ratio too. So, the side of  $\triangle ABC$  should go in the numerator and the sides of  $\triangle XYZ$  should go in the denominator. The triangle or figure listed first in the written-out ratio goes in the numerator and the figure listed second goes in the denominator.

In Example 5 we show that the scale factor could be  $\frac{2}{3}$  or  $\frac{3}{2}$ . It is useful for students to know that either can technically be the scale factor. The important thing is that they know when to use which fraction. Ask students which fraction is larger. Then explain that to find the sides of the *larger* rectangle we would multiply the sides of the smaller triangle by the *larger* ratio. To find the sides of the *smaller* rectangle, we would multiply the sides of the larger rectangle by the *smaller* ratio.

### 1.7. SIMILARITY

## Similarity by AA

### Goal

The purpose of this lesson is to enable students to see the relationship between triangle similarity and proportions. Here we discuss the AA Similarity Postulate and show how it can prove that two triangles are similar.

### Teaching Strategies

Investigation 7-1 is designed to be teacher-led while the student also does the activity and follows along. Students can work individually or in pairs. One option is to have half the students make the triangle with a 3 inch side, like in step 1, and the other half make a triangle with a 4 inch side, like in step 3. Then, have each pair of students compare their two different triangles and complete step 4 together.

Students can find the corresponding sides in two similar triangles by identifying the congruent angles in the two triangles. Then, the sides that are opposite the congruent angles are corresponding. Students can also place the two largest sides together as corresponding, the shortest sides are corresponding and the middle sides are corresponding. You must be careful with this option, however. Students can only use this method when they know that the triangles are similar.

Another option for indirect measurement (other than Example 5) utilizes the Law of Reflection. It states that the angle at which a ray of light (ray of incidence) approaches a mirror will be the same angle in which the light bounces off (ray of reflection). This method is the basis of reflecting points in real world applications such as billiards and miniature golf. See the additional example below.

**Additional Example:** You want to shoot the red ball into the corner pocket, as shown below. How far must the cue ball travel in order to do this?



**Solution:** The answer is the total amount traveled by the cue ball, which is  $36 + x$ . First we need to find  $x$ . Set up a proportion using similar triangles.

$$\begin{aligned}\frac{48}{x} &= \frac{32}{36} \\ 32x &= 1728 \\ x &= 54 \text{ in}\end{aligned}$$

The cue ball must travel  $54 + 36 = 100$  inches to sink the red ball.

---

## Similarity by SSS and SAS

### Goal

The purpose of this lesson is to extend the SSS and SAS Congruence Theorems to include similarity.

### Teaching Strategies

After completing the Review Queue, introduce the lesson by asking students, “How can triangles be congruent and similar simultaneously?” Have a discussion with students about the answer to this question, including how we can prove that triangles are congruent or similar. This will lead into Investigation 7-2.

Investigation 7-2 uses the construction from Chapter 4 for SSS Congruence. Here, students will construct two similar 3-4-5 triangles and then determine if they actually are similar. Have students work in pairs for this activity and circulate to answer questions. Students might need a review of Investigation 4-2 before beginning this investigation. You can show students the provided link in the FlexBook as a review of this construction.

One could say that that SSS Congruence Theorem is a more specific version of the SSS Similarity Theorem. Discuss this point with your students.

As with the previous lesson, make sure students understand which sides are corresponding. If students do not match up corresponding sides, they may get the wrong answer to a homework problem or on a test. Review the points discussed in the previous lesson about how to match up corresponding sides.

Like with Investigation 7-2, you can split the class in half and have one half draw the triangle in step 1 and the other half draw the triangle in step 2 for Investigation 7-3. Then, have students from each half, pair up with someone from the other half and they can do steps 3 and 4 together.

---

## Proportionality Relationships

### Goal

In this lesson, students will learn about proportionality relationships when two parallel lines are split by two transversals.

### Teaching Strategies

Example 1 can be done as a mini-investigation before Investigation 7-4. Discuss the properties of a midsegment and how it splits the two sides that it intersects. Find the ratio of the split sides (1:1) and the ratio of the similar triangles (1:2). Point out that these two ratios are always different.

Investigation 7-4 should be teacher-led and student can follow along, writing down any important information in their notes. They can sketch your drawings and write down your measurements from steps 3 and 6.

To make the proof of Triangle Proportionality Theorem easier to understand, you can utilize the technique presented earlier in this text where you would copy the entire proof, cut out the statements and reasons (separately) and place it in an envelope. Then, students (in pairs or groups) can put the proof in the correct order.

Before introducing Theorem 7-7, show students an example, like Example 4. See if they can figure out the answer. In actuality, Example 4 really is not any different from the examples within triangles, just that the transversals do not intersect. Rather than being sides of triangles, now these lines are the transversals passing through parallel lines. Show students several different orientations (like Example 5), so they not confused by the homework problems.

Proportions with Angle Bisectors can be a little tricky for some students. Tell them to set up the proportion like the picture below:

### 1.7. SIMILARITY

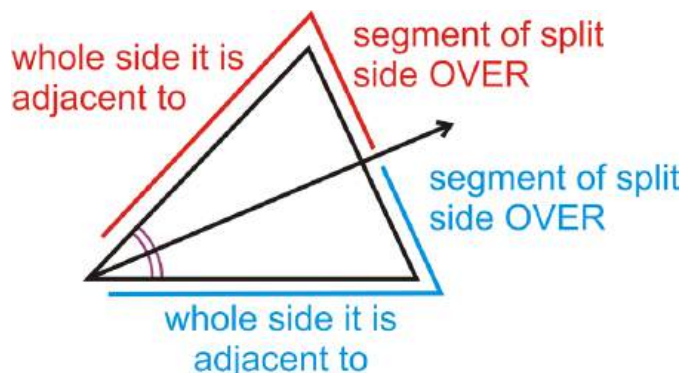

Notice that this set-up is different from the proportion given in Theorem 7-8. Using the letters from the theorem, the proportion would be  $\frac{BC}{AB} = \frac{CD}{AD}$ , which is corollary 7-1.

Encourage students to use this set-up if they are having difficulties with the proportion given in the text.

## Similarity Transformations

### Goal

Dilations produce similar figures. This lesson introduces the algorithm to produce similar figures using measurements and a scale factor.

### Teaching Strategies

To help students with this lesson's Know What? show them pictures of different types of perspective drawings. Here are three very different examples to discuss.



An easy way to remember enlargements versus reductions is a rhyme. Have your students repeat the rhyme, “A reduction is a proper fraction.” Improper fractions are mixed numbers, and greater than 1, thus creating enlargements. Other texts might use other words for enlargements and reductions. Brainstorm with students synonyms for these words. Possibilities are: stretch and shrink or expansion or contraction.

Dilations can also be clarified using a photograph. School pictures are great examples of dilations. Suppose a typical photograph is  $4 \times 6$ . An  $8 \times 10$  enlargement does not alter the appearance. This is also true for shrinking photos for a  $2 \times 3$ . Using a base picture, bring in several enlargements and reductions to further illustrate this concept.

In Examples 1 and 2, a point is dilated. Recall that a point has no dimension, so it cannot be enlarged or reduced. Therefore, the distance from the center of the dilation is stretched and shrunk. Point out to students that the original distance is 6 units and the distance from  $P$  to  $Q'$  is three times 6 units, or 18 units.

Anytime a figure is dilated, the distance from the center of the dilation is also stretched or shrunk according to the scale factor. The dilated point will always be collinear with the original point as well. Even though the terminology image and preimage (the original image) are not introduced until Chapter 12, feel free to introduce it now.

## Extension: Self-Similarity

### Goal

This lesson introduces students to popular fractals. Fractals possess self-similarity and maintain the properties of similarity.

### Teaching Strategies

This optional lesson is a great mathematical connection to art and nature. Show students examples of fractals in art and graphic design. See the examples below. The last picture is a type of broccoli called romanesco broccoli. You can sometimes find it in specialty grocery stores.

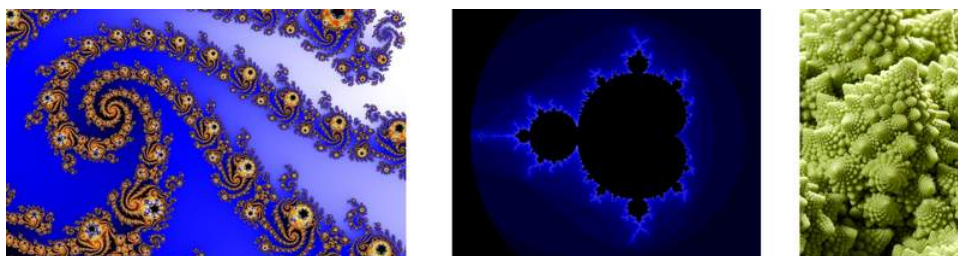

Mathematician Benoit Mandelbrot derived the term “fractal” from the Latin word *frangere*, meaning to fragment. A fractal is a geometric figure in which its branches are smaller versions of the “parent” figure. Most fractals are explained using higher level mathematics; however, students can create their own fractal patterns easily. The Mandelbrot set is illustrated in the middle picture above.

**Additional Example:** Follow these instructions to create a cauliflower fractal.

- Hold your paper in landscape format.
- Draw a horizontal segment  $\overline{AB}$ , such that  $AB = 8$  in, in the center of the paper.
- Find and mark  $C$ , the midpoint of  $\overline{AB}$ .
- Find the midpoint from  $A$  to  $C$ . This is  $\frac{1}{4}AB$ .
- Use this quarter-length to be the length of  $DC$ . Draw  $\overline{DC}$  such that it is perpendicular to  $\overline{AB}$  at  $C$ .
- Draw lines  $\overline{AD}$  and  $\overline{BD}$  forming  $\triangle ADB$ .
- Repeat steps 3-6 for  $\overline{AD}$  and  $\overline{BD}$
- Continue to repeat this process for the legs of each new smaller triangle.

Final image:

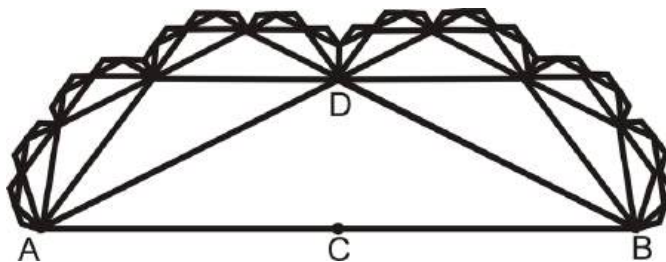

The surface of this fractal (as you continue with smaller and smaller triangles) looks like the outside of a head of cauliflower.





## 1.8 Right Triangle Trigonometry

### Pacing

TABLE 1.11:

<b>Day 1</b> <i>The Pythagorean Theorem</i> Investigation 8-1	<b>Day 2</b> <i>The Pythagorean Theorem Converse</i>	<b>Day 3</b> <b>Quiz 1</b> Start <i>Similar Right Triangles</i>	<b>Day 4</b> Finish <i>Similar Right Triangles</i>	<b>Day 5</b> <i>Special Right Triangles</i> Investigation 8-2
<b>Day 6</b> Finish <i>Special Right Triangles</i> Investigation 8-3	<b>Day 7</b> <b>Quiz 2</b> Start <i>Tangent, Sine, and Cosine Ratios</i>	<b>Day 8</b> Finish <i>Tangent, Sine, and Cosine Ratios</i>	<b>Day 9</b> <i>Solving Right Triangles</i>	<b>Day 10</b> Finish <i>Solving Right Triangles</i>
<b>Day 11</b> <b>Quiz 3</b> Start <i>Review of Chapter 8</i>	<b>Day 12</b> <i>Review Chapter 8</i>	<b>Day 13</b> <b>Chapter 8 Test</b>	<b>Start Chapter 9</b>	

Be sure to take your time with this chapter. Remember that the Pacing Guide is merely a suggestion. Students can get caught up with vocabulary and theorems in this lesson.

### The Pythagorean Theorem

#### Goal

This lesson introduces the Pythagorean Theorem. It has several applications which we will explore throughout this chapter.

#### Relevant Review

Thoroughly review the Simplifying and Reducing Radicals subsection in this lesson. In this and subsequent lessons, answers will be given in simplest radical form. Make sure students know how to add, subtract, multiply, divide, and reduce radicals before moving on. Present anything under the radical like a variable. Students know they cannot add  $2x + 5y$ . Therefore, they cannot combine  $2\sqrt{3} + 5\sqrt{2}$ . This should make it easier for students to understand.

#### Teaching Strategies

Investigation 8-1 provides one proof of the Pythagorean Theorem. First, lead students through steps 1-3, then have them finish step 4 individually while you circle around to answer questions. Once students are done with this investigation, either take students to the computer lab or if you have an LCD screen, go to the site in the FlexBook to see two additional proofs of the Pythagorean Theorem. Both of these proofs are animated and provide another viewpoint.

There are several applications of the Pythagorean Theorem. Students need to be familiar with as many as possible. Go over each example to make sure students understand the range of questions that can be asked. Each of the examples, even though worded differently, are completed the same way. The directions for a given problem can be one place where students can have confusion. Going over the different types of directions for the same type of problem can be very helpful.

Finally the Distance Formula is proven in this lesson. Students might already have an idea of how it works. Explain that it is a variation on the Pythagorean Theorem, especially the before we solve for  $d$ , when the equation looks like  $d^2 = (x_1 - x_2)^2 + (y_1 - y_2)^2$ . Notice in this section, the Distance Formula looks different than it did when it was introduced in Chapter 3. Recall that order does not matter, as long as the corresponding  $x$  or  $y$  value is first ( $x_1$  and  $y_1$  are first or  $x_2$  and  $y_2$  are first).

---

## Converse of the Pythagorean Theorem

### Goal

This lesson applies the converse of Pythagorean's Theorem to determine whether triangles are right, acute, or obtuse.

### Relevant Review

Make sure students are comfortable squaring and simplifying radical numbers.

### Teaching Strategies

The Converse of the Pythagorean Theorem basically says if the sides of a triangle do not satisfy the Pythagorean Theorem, then the triangle is not a right triangle. Theorems 8-3 and 8-4 extend this concept to determine if the non-right triangle is acute or obtuse. To help students remember which is which, tell them to think opposite. When  $a^2 + b^2 > c^2$  ( $a^2 + b^2$  is *greater than*  $c^2$ ) the triangle is acute (all angles are *less than*  $90^\circ$ ). When  $a^2 + b^2 < c^2$  ( $a^2 + b^2$  is *less than*  $c^2$ ) the triangle is obtuse (one angle is *greater than*  $90^\circ$ ). Also, when in doubt, have them draw the triangle, as best they can, to scale. Then, they can see what the triangle should be and they can do the Pythagorean Theorem to confirm or deny.

Remind students that the Triangle Inequality Theorem still holds. So, if they are given lengths like 5, 7, and 15, they need to be able to recognize that these lengths do not make a triangle at all.  $5 + 7 > 15$ , so no triangle can be formed. If students do not see this, they will be doing unnecessary work, not to mention think that the triangle is obtuse. Review the Triangle Inequality Theorem as you are going through the examples in the text. No one likes to do extra work, if they do not have to.

**Additional Example:** Do the following lengths form a triangle? If so, is it acute, right, or obtuse?

a) 10, 15, 20

b) 7, 14, 21

c)  $8\sqrt{2}$ ,  $4\sqrt{6}$ ,  $4\sqrt{14}$

**Solution:** First, check all the lengths to see if they make a triangle. b) does not,  $7 + 14 = 21$ , so those lengths cannot make a triangle. Let's see what type of triangles a) and c) are.

a)

$$10^2 + 15^2 = 20^2$$

$$100 + 225 < 400$$

obtuse triangle

c)

$$(8\sqrt{2})^2 + (4\sqrt{6})^2 = (4\sqrt{14})^2$$

$$64 \cdot 2 + 16 \cdot 6 = 16 \cdot 14$$

$$128 + 96 = 224$$

right triangle

**Additional Example:** Find an integer such that 9, 12, \_\_\_\_ represent an acute or obtuse triangle.

**Solution:** 9, 12, 15 would be a right triangle (this is a multiple of the Pythagorean triple, 3-4-5). So 8, 9, 10, 11, 12, 13, or 14 would work. If the integer is less than 8, then the triangle would be obtuse, with 12 as the longest side.

For an obtuse triangle, the third side could be less than 8, but greater than  $3(9 + 3 = 12)$ . And, it could also be greater than 15, but less than  $21(9 + 12 = 21)$ . So, the possibilities are 4, 5, 6, 7, 16, 17, 18, 19, or 20.

---

## Using Similar Right Triangles

### Goal

Students will review similar triangles, primarily right triangles. Then, the concept of the geometric mean is introduced and applied to right triangles.

### Relevant Review

Review similar triangles and their properties briefly before introducing Theorem 8-5. The two triangles formed by the altitude from the right angle in a right triangle are similar to the larger right triangle by AA (see Example 1). Show students how the three triangles fit together and which angles are congruent to each other and which sides are proportional (Examples 1 and 2).

Also, remind students that answers should be in simplest radical form. You may need to add a few simplifying and reducing radical questions in the Review Queue.

### Teaching Strategies

Example 3 introduces the geometric mean as it applies to right triangles. You can choose to use this example before discussing the geometric mean or after it, after Example 7. It might be easier for students to see the geometric in its literal, algebraic form (without being applied to triangles) and practice it that way for a few examples, and then apply it to a right triangle.

In Examples 5 and 6, it might be helpful to show students the corresponding proportions for the geometric mean,  $\frac{24}{x} = \frac{x}{36}$  and  $\frac{18}{x} = \frac{x}{54}$ . Students will like the short cut,  $x = \sqrt{ab}$ , but they should be shown the proportion first. The proportion directly relates to its application to right triangles.

Examples 3 and 7 apply the geometric mean to the right triangle. The set-up of these proportions, using similar triangles, is the same as the geometric mean. So, students can always use similar triangles, rather than memorize the geometric mean.

So often in math, there are two or even three ways to solve one problem. In Example 8, there are two ways presented to solve for  $y$ . Encourage students to try the geometric mean, but they can also use the Pythagorean Theorem. Show students both methods and then brainstorm why one method could be preferred over the other. Students should be allowed to use which ever method they feel more comfortable with.

---

## Special Right Triangles

### Goal

The purpose of this lesson is to encourage the use of ratios to find values of the sides of special right triangles. These triangles are extremely useful in trigonometry.

### Relevant Review

Special right triangle ratios are extended ratios. Here is an additional Review Queue question:

### 1.8. RIGHT TRIANGLE TRIGONOMETRY

**Additional Review Queue:** The sides of a triangle are in the extended ratio 3:7:9. If the shortest side is 21, find the length of the other two sides.

**Solution:** We will rewrite the ratio as  $3x : 7x : 9x$ . So,  $3x = 21$ , which means  $x = 7$ . Therefore, the other two sides are  $7 \cdot 7 = 49$  and  $9 \cdot 7 = 63$ .

### Teaching Strategies

Students should complete Investigation 8-2 independently. Lead students through step 1, but then allow them to complete the Pythagorean Theorem in steps 2 and 3 on their own. Ask students if they see a pattern among the hypotenuses. Then, go over how to solve an isosceles triangle given various sides and with various square roots. They should know how to solve an isosceles right triangle when the legs are not whole numbers. To find the legs, always divide the hypotenuse by  $\sqrt{2}$  and then simplify the radical. (Students might also notice there is a pattern here too. The leg will be the hypotenuse divided by 2 and multiplied by  $\sqrt{2}$ . For example, if the hypotenuse is 20, the legs will be  $20 \div 2 \cdot \sqrt{2} = 10\sqrt{2}$ . This is a little short cut.) To find the hypotenuse, multiply the leg by  $\sqrt{2}$ . Students may need to simplify the square root. Also, the diagonal of a square will always split the square into two 45-45-90 triangles. Make sure students notice this connection.

With 30-60-90 triangles, students must make the connection that it is half an equilateral triangle. In Investigation 8-3, lead students through steps 1-3, then allow the students complete steps 4 and 5 on their own. Students will have a hard time remembering this extended ratio. Some students will think that  $x\sqrt{3}$  should be the hypotenuse because 3 is bigger than 2. However, explain that  $\sqrt{3} \approx 1.73$ , which is smaller than 2, so  $2x$  will always be the longest side, which is the hypotenuse. To solve 30-60-90 triangles, students will need to find the shortest leg, if they are not given it. If they are given the hypotenuse, divide by 2, then they can multiply by  $\sqrt{3}$  to get the longer leg. If they are given the longer leg, they will need to divide by  $\sqrt{3}$  (or use the shortcut as applied to the 45-45-90 triangle above, use 3 and  $\sqrt{3}$  where appropriate) to get the shorter leg, then multiply that by 2.

Students will also get these two ratios confused. One way to help them remember is for a 45-45-90 triangle there are 2  $45^\circ$  angles, so the hypotenuse is  $x\sqrt{2}$ . For a 30-60-90 triangle all the angles are divisible by 3, so the  $\sqrt{3}$  is in the radical for this ratio.

The best way for students to become comfortable with these ratios is to have them do lots of problems. Students can also make flashcards for these ratios. If students have trouble remembering these special shortcuts, encourage them to use Pythagorean's Theorem and simplify the answer. The resulting answer will equal the shortcut.

---

## Tangent, Sine and Cosine

### Goal

This lesson introduces the trigonometric functions; sine, cosine and tangent.

### Teaching Strategies

Before introducing the trig ratios, make sure students understand what adjacent and opposite mean and which angles they are in reference to.  $c$  will always be the hypotenuse, but  $a$  and  $b$  can be either opposite or adjacent, depending on which acute angle we are using. At this point, do not overwhelm students with the fact that the trig functions can be applied to any angle; focus on acute angles in triangles.

Encourage students to make flash cards for the sine, cosine and tangent ratios and to use the pneumonic SOH-CAH-TOA (in FlexBook). Both of these things will help students internalize the ratios.

In the types of problems in this lesson, it will be very common that two of the three sides are given and students will need to use the Pythagorean Theorem to find the third side. This should always be done first, and then they can apply the ratios. Students will also need to reduce ratios and simplify any radicals. Show students several different orientations of the triangles (rotated, flipped, etc) so they are familiar with where an angle is and which sides are adjacent and opposite.

Have each student check to ensure their calculator is set to degrees (DEG), not radians (RAD). Having a calculator in radians will provide incorrect answers. When checking homework at the beginning of the class period, check the mode of students' calculators as well.

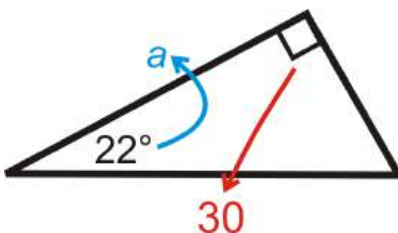

When introducing how to find the sides of a right triangle, using the trig ratios, draw the triangle from Example 5 on the board with only one variable,  $a$ . This will isolate  $a$  and students should be able to see that the cosine ratio will solve for  $a$ . Use the arrow to help illustrate that  $a$  is adjacent to  $22^\circ$  and 30 is the hypotenuse. After  $a$  is found, redraw the triangle so  $b$  is the only variable. Now,  $b$  is isolated and students will be able to recognize that the sine ratio will solve for it. Again, use arrows, if needed.

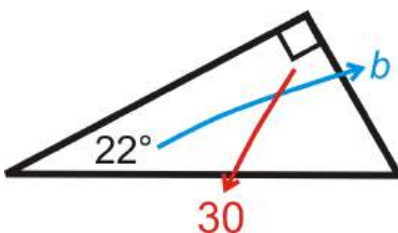

Stress to students that they should only use information that they are given in the problem. Using “solved for” information will not give them the most accurate answer or it could be completely wrong (if the “solved for” answer used is incorrect).

To help illustrate the angles of elevation and depression, see the picture below.

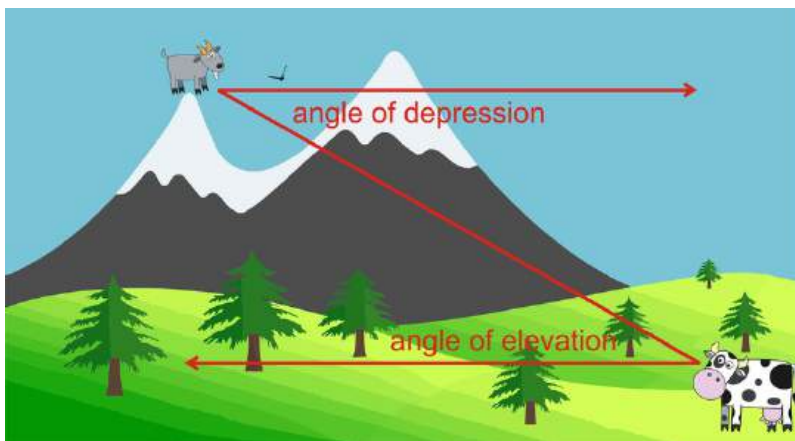

Show this to students and ask what the angle of elevation from the cow to the goat is. Then, ask what the angle of depression from the sheep down to the cow is. Students should notice it is the same measurement and alternate interior angles. Fill in the angle of depression/elevations with any measurement.

---

## Inverse Trigonometric Ratios

### Goal

#### 1.8. RIGHT TRIANGLE TRIGONOMETRY

In the previous lesson, students used the special trigonometric values to determine approximate angle measurements. This lesson enables students to “cancel” a trigonometric function by applying its inverse to accurately find an angle measurement.

### Relevant Review

Begin by listing several mathematical operations on the board in one column. In a second column, title it “Inverse.” Be sure students understand what an inverse means (an inverse cancels an operation, leaving the original value undisturbed).

**TABLE 1.12:**

<i>Operation</i>	<i>Inverse</i>	<i>Example</i>
Addition		
Multiplication		
Squaring		
Sine		
Cosine		
Tangent		

The first four are typically easy for students (Subtraction, square root, multiplication, and addition). You may have to lead students a little more on the last two (inverse tangent and inverse sine). Students may say, “Un-tangent it.” Use the correct terminology here, but also use their wording, if at all possible. Students will be able to cancel the trigonometric function using the inverse of that function, even though they may use incorrect terminology.

Go over Example 1 thoroughly. Make sure every student understands how to input inverse trig functions into their calculator. Remind students that the set-up for inverse problems is the same as those from the previous lesson. However, instead of being given an angle measure, we leave it as a variable. Students need to solve for the angle and then put everything into the calculator at the same time. Get them in this habit so they will produce the most accurate answers. For example:

$$\underline{\text{Yes}} : \sin^{-1}\left(\frac{2}{3}\right) \qquad \underline{\text{No}} : \sin^{-1}(0.666)$$

Example 5 is a special right triangle. Students will probably go through the motions and not notice that they can use the ratios learned in the Special Right Triangles lesson. Either way, students will still arrive at the correct answer, but point out to them to not go blindly into each question. Read a problem, re-read, and then decide how to answer.

Like the last lesson, real-life situations are a major application. At the end of this lesson, create a word problem as a class. Use the names of students or find the height of a local building. Make the problem personal. Then, add it to the test as an extra question or a bonus.

## 1.9 Circles

### Pacing

TABLE 1.13:

<b>Day 1</b> <i>Parts of Circles &amp; Tangent Lines</i> Investigation 9-1	<b>Day 2</b> <i>Finish Parts of Circles &amp; Tangent Lines</i> Start <i>Properties of Arcs</i>	<b>Day 3</b> <i>Finish Properties of Arcs</i>	<b>Day 4</b> <b>Quiz 1</b> Start <i>Properties of Chords</i>	<b>Day 5</b> <i>Finish Properties of Chords</i> Investigation 9-2 Investigation 9-3
<b>Day 6</b> <i>Inscribed Angles</i> Investigation 9-4	<b>Day 7</b> <i>Finish Inscribed Angles</i> Investigation 9-5	<b>Day 8</b> <b>Quiz 2</b> Start <i>Angles from Chords, Secants, and Tangents</i> Investigation 9-6	<b>Day 9</b> <i>Finish Angles from Chords, Secants and Tangents</i> Investigation 9-7 Investigation 9-8	<b>Day 10</b> <i>Segments from Secants and Tangents</i>
<b>Day 11</b> <b>Quiz 3</b> *Start <i>Extension: Equations of Circles</i>	<b>Day 12</b> *Finish <i>Extension: Equations of Circles</i>	<b>Day 13</b> <i>Review for Chapter 9 Test</i>	<b>Day 14</b> <b>Chapter 9 Test</b>	<b>Day 15</b> <b>Start Chapter 10</b>

### Parts of Circles & Tangent Lines

#### Goal

This lesson introduces circles and several parts of circles. Then, we will explore the properties of tangent lines.

#### Notation Note

$\odot$  is the symbol for a circle. A circle is labeled using this symbol and its center. Some textbooks place a dot in the center, some do not. Do not confuse this symbol with an uppercase  $O$ .

#### Teaching Strategies

There is a lot of vocabulary in this chapter. Encourage students to make flash cards for each word and the theorems. Give students index cards at the end of each class period so they can make flash cards in the last 5-10 minutes of all the terms they learned.

Discuss with students where one could find tangent circles, tangent lines, concentric circles, and intersecting circles in real life. Concentric circles can also be formed when raindrops hit a body of water, such as a lake or puddle. An example of intersecting circles can be a Venn diagram. Common external tangent lines could be the gears of a bicycle.

Investigation 9-1 can be done as a teacher-led activity or individually. For step 2, it can be difficult for students to draw a perfectly tangent line at point  $B$ . You may need to circulate to ensure they each student has the correct drawing, to ensure that they get the correct measurement of  $\angle ABC$ . After measuring  $\angle ABC$ , ask students if they think this will happen at angle drawn to the point of tangency. Feel free to repeat this investigation with a larger or smaller circle so students can see two different cases. Lead them towards the Tangent to a Circle Theorem.



In this lesson and chapter, students will need to apply the Pythagorean Theorem. Having a tangent line and a radius that meet at the same point will always produce a  $90^\circ$  angle. Therefore, students will need to recall all the information they learned in the last chapter (special right triangles, Pythagorean Theorem and its converse, and the trig ratios). Review these points, if needed, and proceed with Example 4.

Example 6 is an important example because it uses the converse of the Pythagorean Theorem to show that  $B$  is not a point of tangency. Make sure students understand this point. In Example 7, students will need to draw an additional line,  $\overline{EB}$ . Encourage students to draw in additional lines if ever needed.

If students wonder the reasoning behind Theorem 9-2, draw in radii  $\overline{AD}$  and  $\overline{AB}$  and segment  $\overline{AC}$ . You can give students this additional example.

**Additional Example:** Put the reasons for the proof of Theorem 9-2 in the correct order.

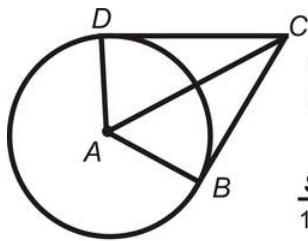

Given: Radii  $\overline{AD}$  and  $\overline{DB}$ , tangent lines  $\overline{DC}$  and  $\overline{BC}$   
 Prove:  $\overline{DC} \cong \overline{BC}$

Statement	Reason
1. Radii $\overline{AD}$ and $\overline{DB}$ , tangent lines $\overline{DC}$ and $\overline{BC}$	A. CPCTC
2. $\overline{AD} \cong \overline{DB}$	B. Given
3. $\angle CDA$ and $\angle CBA$ are right angles.	C. HL Congruence Theorem
4. $\overline{AC} \cong \overline{AC}$	D. Tangent to a Circle Theorem
5. $\triangle ADC \cong \triangle ABC$	E. All radii are congruent
6. $\overline{DC} \cong \overline{BC}$	F. Reflexive Property of Congruence

**Solution:** B, E, D, F, C, and A.

## Properties of Arcs

### Goal

This lesson introduces arcs, central angles, their properties and how to measure them.

### Notation Note

Use a curved line above the endpoints of the arc to label it. Some arcs, such as major arcs, require three letters to label it. Explain to students that they must use three letters for some arcs to distinguish between the two different arcs that have the same endpoints. If only two letters are used to label an arc, it is assumed that the arc is less than  $180^\circ$ .

### Teaching Strategies

When introducing arcs, discuss with students where they might see arcs and degrees in real life. Examples are pizza crust, pie crust, a basketball hoop (the rim), among others. An arc could be a piece of pizza crust or pie crust. Some students might be familiar with skateboarding or snowboarding. A  $360^\circ$  jump is one rotation, a  $540^\circ$  is one-and-a-half rotations, and a  $720^\circ$  is two full rotations. The link below is Shaun White from the 2010 Winter X Games. In the second and third jumps, see if students can determine how many rotations he does. <http://www.youtube.com/watch?v=phZow-WZ96A>

Make sure that students are comfortable with finding arc measures using central angles. This is the beginning of arc measures and corresponding angles in circles, so having a solid foundation is important. In Example 3, there are more

congruent arcs than the ones that are listed. See if students can find other possibilities:  $\widehat{DAE} \cong \widehat{DBE} \cong \widehat{ADB} \cong \widehat{AEB}$  (all semicircles),  $\widehat{ADE} \cong \widehat{DAB}$ , and  $\widehat{DBA} \cong \widehat{EDB}$ . This would also be a good time to discuss different ways to label the same major arc. For example,  $\widehat{ADE}$  from above could also have been labeled  $\widehat{ABE}$ .

The Arc Addition Postulate should be familiar to students; it is very similar to the Segment Addition Postulate and the Angle Addition Postulate. Rather than adding segments or angles, we are now adding arcs. This is a very useful postulate when trying to find all the arcs in a circle.

## Properties of Chords

### Goal

Students will find the lengths and learn the properties of chords in a circle.

### Notation Note

There is no explicit way to mark that two arcs are congruent in a picture. Students will have to infer from other information if two arcs are congruent or not. Ways that they can tell are: if corresponding chords are congruent or if the central angles are congruent.

### Teaching Strategies

Make sure students understand all the possible ways to interpret Theorem 9-3. First, if the chords are congruent, then the arcs are congruent. Second, the converse is also true (you may need to review “if and only if” and biconditional statements). Finally, you can also say that if the central angles are congruent, then the arcs are congruent AND the chords are congruent. The converse of this statement is also true.

In Investigation 9-2, the construction tells us that a diameter bisects a chord. From this, students should also see that the diameter is perpendicular. Therefore, the perpendicular bisector of a chord is also a diameter (Theorem 9-4). Stress to students that other chords can be perpendicular to a chord and other chords can bisect a chord, but only the diameter is both. Remind students that every line segment has exactly one perpendicular bisector. Also, students should understand that not every diameter drawn that intersects a given chord will be its perpendicular bisector. This investigation is best done as a teacher-led activity.

Like Theorem 9-3, make sure students understand all the possible ways to interpret Theorems 9-4 and 9-5. Be careful, though. Write the converse of Theorem 9-4; if a line is a diameter, then it is also the perpendicular bisector of a chord. At first glance, students might think this is a true statement. Show students a counterexample or have a student come up and draw one (see Example 3). However, the converse of Theorem 9-5 is true; if the diameter bisects a chord and its corresponding arc, then the diameter is also perpendicular to the chord. When applying these theorems to a diagram, two of the following three things must be marked: chord is bisected, diameter passes through the center (to ensure that this chord is actually a diameter), or diameter is perpendicular to the chord. If two of these are marked, then it can be inferred that the third is also true.

Investigation 9-3 and Theorem 9-6 apply Theorems 9-3, 9-4, and 9-5 to two congruent chords in the same circle (or congruent circles). If you want, you can continue Investigation 9-3 on the same circle from Investigation 9-2. Draw a second chord that is the same length as  $\overline{BC}$  (from Investigation 9-2) somewhere else in the circle. You can repeat step 2 from Investigation 9-2, rather than using step 2 from Investigation 9-3 as well. Both steps will produce the same result.

Review with students the definition of equidistant and why the shortest distance between a point and a line is the perpendicular line between them. In order for two chords to be congruent, using Theorem 9-6, the segments from the center to the chords must be marked congruent and perpendicular. Ask students if they notice any other properties of these segments. Students should notice that these segments are part of a diameter and that they also bisect each chord.

Finally, you can show students the following picture and see if they can find all the congruent chords, segments and

arcs. Tell them that  $\overline{BE} \cong \overline{IF}$ . This diagram applies all the theorems learned in this lesson.

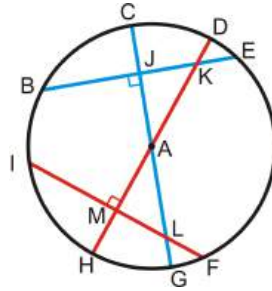

$$\overline{BJ} \cong \overline{JE} \cong \overline{IM} \cong \overline{MF}$$

$$\widehat{BC} \cong \widehat{CE} \cong \widehat{HF} \cong \widehat{HI}$$

$$\overline{CA} \cong \overline{AD} \cong \overline{AG} \cong \overline{AH}$$

$$\widehat{CD} \cong \widehat{HG}$$

$$\overline{CJ} \cong \overline{MH}$$

$$\widehat{DE} \cong \widehat{GF}$$

$$\overline{JK} \cong \overline{ML}$$

$$\widehat{CH} \cong \widehat{DG}$$

$$\overline{KE} \cong \overline{LF}$$

$$\overline{JA} \cong \overline{AM}$$

$$\overline{AL} \cong \overline{AK}$$

$$\overline{DK} \cong \overline{LG}$$

\*There are semicircles and major arcs that are also congruent.

And,  $\triangle JKA \cong \triangle MLA$  by HL, SSS, or ASA

## Inscribed Angles

### Goal

This lesson will demonstrate how to find measures of inscribed angles and intercepted arcs.

### Relevant Review

At this point, it would be very helpful to review all the theorems and vocabulary learned in this chapter. Make sure students have a firm grasp on the chapter up to this point. The chapter gets continually harder, so it is important that they have a strong foundation.

Double-check that every student has his/her flash cards of vocabulary and theorems and make sure they are using them regularly. One way to spot-test students on vocabulary is to have them lie out all their flash cards with the vocab or the name of the theorem side up. Then, you read the definition or theorem out loud. The first student to raise the correct card gets some sort of reward; either candy or an extra credit point. You can also tally the points and if any student reaches 5 (or any number of your choosing), then they will receive extra credit or a homework pass.

### Teaching Strategies

It is very important that students understand how an inscribed angle and intercepted arc are defined and relate to each other. Any angle in a circle can (and usually does) have an intercepted arc, even though it is defined in terms of an inscribed angle. The important point to note is that the intercepted arc is the interior arc with the given endpoints on the circle. The blue arcs below are considered intercepted arcs for the inscribed angles below.

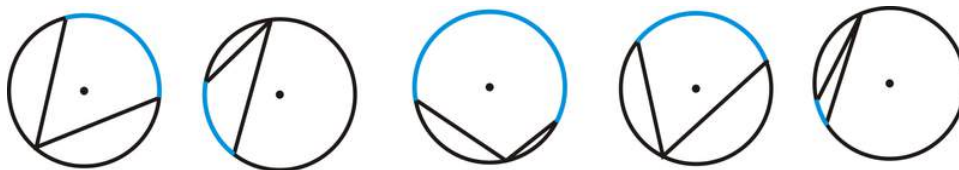

For Investigation 9-4, it might be helpful to already have three (or more) drawn inscribed angles on a handout for students. Pass these out and they still should draw in the corresponding central angle. Do not rush through this activity. Walk around to answer questions and let students arrive at the Inscribed Angle Theorem on their own. Then, proceed with lots of practice problems and examples to get students used to using this theorem.

Draw the pictures for Theorems 9-8 and 9-9 before telling the students what exactly the theorems are. For Theorem 9-8, ask students if they can conclude anything about  $\angle ADB$  and  $\angle ACB$ . For Theorem 9-9, ask students what the measure of the intercepted arc is, then they should be able to determine the measure of the inscribed angle. Here, the wording might be a little off from what is in the theorem. Make sure students can infer everything from these two theorems. First, in 9-8, the triangles created are only similar, not necessarily congruent. In 9-9, the endpoints of the inscribed angles are on a diameter and the diameter would be the hypotenuse of a right triangle.

Investigation 9-5 should be a teacher-led demonstration that can easily be done on an overhead projector (pre-cut a transparency into an inscribed quadrilateral and color the angles). Guide students towards the next theorem. The word “cyclic” is not used to describe these types of quadrilaterals. You can choose whether or not you would like to introduce this vocabulary or use what is in the text.

## Angles of Chords, Secants, and Tangents

### Goal

This lesson further explores angles in circles. Students will be able to find the measures of angles formed by chords, secants, and tangents.

### Teaching Strategies

This lesson divides angles in circles into three different categories: angles with the vertex ON the circle, angles with the vertex IN the circle, and angles with the vertex OUTSIDE the circle.

central angle = intercepted arc

angle inside = *half the sum* of the intercepted arcs

angle on circle = *half* intercept arc

angle outside = *half the difference* of the intercepted arcs

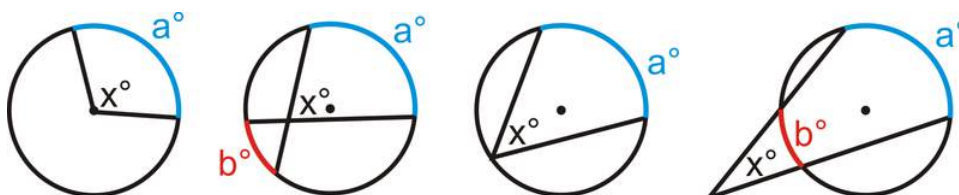

Use the pictures above to help students generate formulas for each case. Then, draw the other options for angles on circles and angles outside circles.

### 1.9. CIRCLES

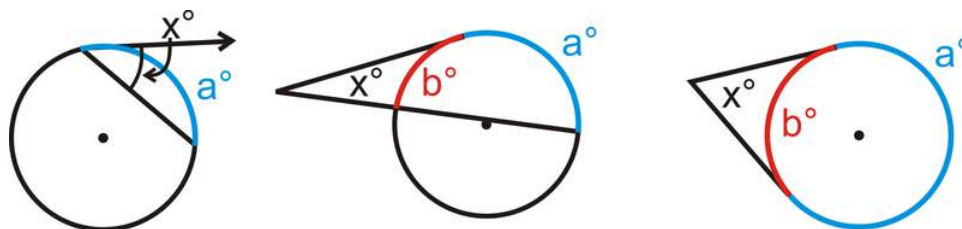

Example 2 shows students that Theorem 9-8 (from the previous lesson) works for any angle where the vertex is on the circle.

Investigations 9-6, 9-7, and 9-8 can all be teacher-led investigations where students follow along and the class discovers the formulas together. Allow students to guess the possibilities for the formulas, even if they are wrong. Developing the correct formula will give students ownership over the material and it will help them retain the information.

Make sure you do plenty of practice problems in class to ensure that students are using the correct formula in the appropriate place. Give students a handout with several problems. You can choose to put the formulas on the board, let them use notes, or use nothing at all. Include problems from the previous lesson(s) as well.

## Segments of Chords, Secants, and Tangents

### Goal

This goal of this lesson is to explain the formulas for determining segment lengths formed by intersecting secants and tangents.

### Relevant Review

Students might need a little algebraic review with solving quadratic equations. Problems involving tangents and secants can become a factoring problem or use the quadratic formula. Students might also need a review of square roots and simplifying square roots.

### Teaching Strategies

Get students organized with all the information from this lesson and the previous two lessons. Have students draw and complete the following table.

**TABLE 1.14:**

#### **Picture**

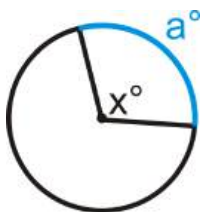

#### **Angle Formula**

$$x^\circ = a^\circ$$

#### **Segment Formula**

Sides of angle are radii. No formula

**TABLE 1.14:** (continued)

**Picture**

**Angle Formula**

**Segment Formula**

$$x^\circ = \frac{1}{2}(a^\circ + b^\circ)$$

$$pq = sr$$

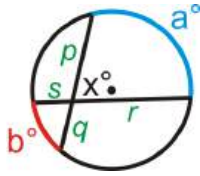

$$x^\circ = \frac{1}{2}a^\circ$$

Sides are chords. No formula.



$$x^\circ = \frac{1}{2}a^\circ$$

One side is a chord, other is a ray. No formula.

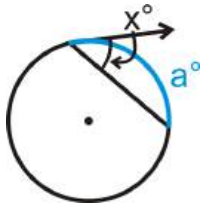

$$x^\circ = \frac{1}{2}(a^\circ - b^\circ)$$

$$s(s + p) = q(q + r)$$

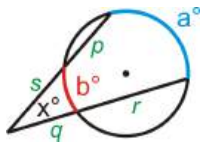

$$x^\circ = \frac{1}{2}(a^\circ - b^\circ)$$

$$s^2 = q(q + r)$$

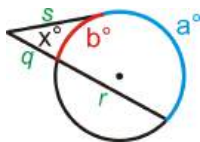

$$x^\circ = \frac{1}{2}(a^\circ - b^\circ)$$

$$s = q$$

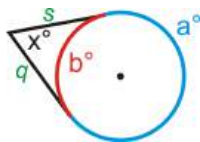

---

## Extension: Writing and Graphing the Equations of Circles

Show students how a point can be on a circle, using the Pythagorean Theorem. For example, if the equation of a circle is  $x^2 + y^2 = 25$ , is (3, -4) on the circle? Yes. If students plug in 3 for  $x$  and -4 for  $y$ , they will see that the Pythagorean Theorem holds true. Conversely, if we tested (-6, 2), we would find that it is not on the circle because  $36 + 4 \neq 25$ .

In Example 3, students might have problems finding the diameter. Remind them that the diameter is the longest chord in a circle. Students would need to count the squares vertically and horizontally to see where the longest segment would be (within the circle).

# 1.10 Perimeter and Area

## Pacing

TABLE 1.15:

Day 1	Day 2	Day 3	Day 4	Day 5
<i>Triangles and Parallelograms</i>	<i>Trapezoids, Rhombi, and Kites</i>	<i>More Trapezoids, Rhombi, and Kites</i> <i>Start Area of Similar Polygons</i>	<i>Finish Area of Similar Polygons</i>	<i>Quiz 1</i> <i>Start Circumference and Arc Length</i>
Day 6	Day 7	Day 8	Day 9	Day 10
<i>Finish Circumference and Arc Length</i> <i>Investigation 10-1</i>	<i>Area of Circles and Sectors</i>	<i>Quiz 2</i> <i>Start Review of Chapter 10</i>	<i>Review of Chapter 10</i>	<i>Chapter 10 Test</i>

## Triangles and Parallelograms

### Goal

This lesson introduces students to the area and perimeter formulas for triangles, parallelograms and rectangles.

### Relevant Review

Most of this lesson should be review for students. They have learned about area and perimeter of triangles and rectangles in a previous math class (Math 6, Pre-Algebra, or equivalent).

### Notation Note

In this chapter, students need to use square units. If no specific units are given, students can write units<sup>2</sup> or  $u^2$ .

### Teaching Strategies

If students are having a hard time with the formulas for area and perimeter of a rectangle, place Example 3 on a piece of graph paper or transparency. Then, students can count the squares for the area and perimeter and you can generate the formula together.



If you count all the squares, there are 36 squares in the area, or square centimeters (red numbers). Counting around the rectangle (blue numbers), we see there are 26 squares. Therefore, the perimeter of this square is 26 cm.



*This technique will also work for squares.*

An important note, each problem will have some sort of units. Remind students that the shapes might not always be drawn to scale.

Example 5 is a counterexample for the converse of the Congruent Areas Postulate. Therefore, the converse is false. An additional counterexample would be to have them draw all the possible rectangles with an area of  $20 \text{ in}^2$ . Use graph paper so students will see that each rectangle has 20 squares. Possible answers are:  $20 \times 1$ ,  $10 \times 2$ , and  $5 \times 4$ .

The Area Addition Postulate encourages students to separate a figure into smaller shapes. Always divide the larger shape into smaller shapes that students know how to find the area of.

To show students the area of a parallelogram, cut out the picture (or draw a similar picture to cut out) of the parallelogram and then cut the side off and move it over so that the parallelogram is transformed into a rectangle. Explain to students that the line that you cut is the height of the parallelogram, which is not a side of the parallelogram. Then, cut this parallelogram along a diagonal to create a triangle. Here, students will see that the area of a triangle is half the area of a parallelogram. You may need to rotate the halves (triangles) so that they overlap perfectly. This will show the students that the triangles are congruent and each is exactly half of the parallelogram.

Create another set of flashcards for the area formulas in this chapter. These flashcards should be double-sided. The blank side should be a sketch of the figure and its name. The flip side should have the formula for its area and the formula for its perimeter. Students should create flashcards as the chapter progresses.

---

## Trapezoids, Rhombi, and Kites

### Goal

This lesson further expands upon area formulas to include trapezoids, rhombi, and kites.

### Relevant Review

Students might need a quick review of the definitions of trapezoids, rhombi, and kites. Go over their properties (especially that the diagonals of rhombi and kites are perpendicular) and theorems. Students may know the area formula of a trapezoid from a previous math class.

Review the Pythagorean Theorem and special right triangles. There are several examples and review questions that will use these properties. If students do not remember the special right triangle ratios, they can use the Pythagorean Theorem.

### Teaching Strategies

Use the same technique discussed in the previous lesson for the area of a parallelogram and triangle. Cut out two congruent trapezoids and demonstrate the explanation at the beginning of the lesson explaining the area of a trapezoid. Going over this with students (rather than just giving them a handout or reading it) will enable them to understand the formula better. These activities are done best on an overhead projector.

Conveniently, the area formula of the rhombus and kite are the same. Again, you can cut out a rhombus and kite, then cut them on the diagonals and piece each together to form a rectangle. Generate the formula with students. Another way to write the formula of a rhombus is to say that it has 4 congruent triangles, with area  $\frac{1}{2} \left( \frac{1}{2} d_1 \right) \left( \frac{1}{2} d_2 \right) = \frac{1}{8} d_1 d_2$ . Multiplying this by 4, we get  $\frac{4}{8} d_1 d_2 = \frac{1}{2} d_1 d_2$ . This process is not as easily done with a kite because one of the diagonals is not bisected.

**Additional Example:** Find two different rhombi that have an area of 48 units<sup>2</sup>.

**Solution:** The diagonals are used to find the area, so when solving this problem, we are going to be finding the diagonals' lengths.  $\frac{1}{2} d_1 d_2 = 48$ , so  $d_1 d_2 = 96$ . This means that the product of the diagonals is double the area.

The diagonals can be: 1 and 96, 2 and 48, 3 and 32, 4 and 24, 6 and 16, 8 and 12.

As an extension, you can students draw the rhombi. The diagonals bisect each other, so have the diagonals cut each other in half and then connect the endpoints of the diagonals to form the rhombus. Three examples are below.

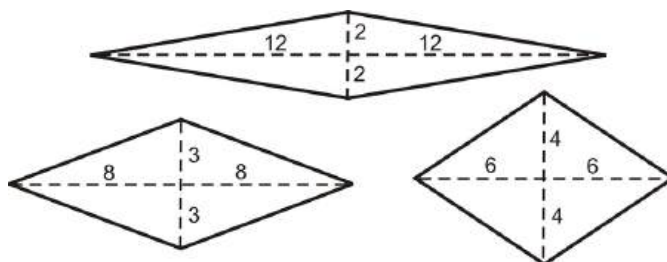

## Areas of Similar Polygons

### Goal

Students will learn about the relationship between the scale factor of similar polygons and their areas. Students should also be able to apply area ratios to solving problems.

### Relevant Review

Review the properties of similar shapes, primarily triangles and quadrilaterals, from Chapter 7. Remind students that the perimeter, sides, diagonals, etc. have the same ratio as the scale factor. The Review Queue reviews similar squares. As an additional question, ask students to find the perimeter of both squares and then reduce the ratio (smaller square = 40, larger square = 100, ratio is 2:5, the same as the ratio of the sides). Ask students why they think the ratio of the sides is the same as the ratio of the perimeters.

### Teaching Strategies

Examples 1 and 2 lead students towards the Area of Similar Polygons Theorem. As an additional example (before introducing the Area of Similar Polygons Theorem), ask students to find the area of two more similar shapes. Having students repeat problems like Example 2, they should see a pattern and arrive at the theorem on their own.

**Additional Example:** Two similar triangles are below. Find their areas and the ratio of the areas. How does the ratio of the areas relate to the scale factor?

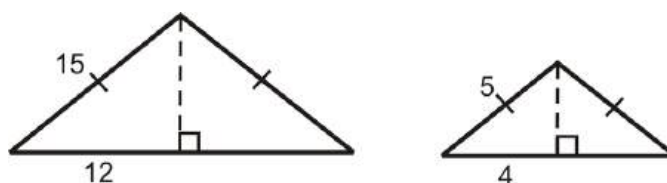

**Solution:** Each half of the isosceles triangles are 3-4-5 triangles. The smaller triangle has a height of 3 and the larger triangle has a height of 9 (because 12 is 3 times 4, so this triangle is three times larger than the smaller triangle). The areas are:  $A_{larger \Delta} = \frac{1}{2} \cdot 24 \cdot 9 = 108$  and  $A_{smaller \Delta} = \frac{1}{2} \cdot 8 \cdot 3 = 12$ . The ratio of the area is  $\frac{12}{108} = \frac{1}{9}$ . The ratios of the scale factor and areas relate by squaring the scale factor,  $\frac{1}{9} = \left(\frac{1}{3}\right)^2$ .

## Circumference and Arc Length

### Goal

#### 1.10. PERIMETER AND AREA

The purpose of this lesson is to review the circumference formula and then derive a formula for arc length.

### Relevant Review

The Review Queue is a necessary review of circles. Students need to be able to apply central angles, find intercepted arcs and inscribed angles. They also need to know that there are  $360^\circ$  in a circle.

### Teaching Strategies

Students may already know the formula for circumference, but probably do not remember where  $\pi$  comes from. Investigation 10-1 is a useful activity so that students can see how  $\pi$  was developed and why it is necessary to find the circumference and area of circles. You can decide to make this investigation teacher-led or allow students to work in pairs or groups. From this investigation, we see that the circumference is dependent upon  $\pi$ .

When introducing arc length, first have students find the circumference of a circle with radius of  $6(12\pi)$ . Then, see what the length of the arc of a semicircle ( $6\pi$ ). Students should make the connection that the arc length of the semicircle will be half of the circumference. Then ask students what the arc length of half of the semicircle is ( $3\pi$ ). Ask what the corresponding angle measure for this arc length would be ( $90^\circ$ ). See if students can reduce  $\frac{90}{360}$  and if they make the correlation that the measure of this arc is a quarter of the total circumference, just like  $90^\circ$  is a quarter of  $360^\circ$ . Using this same circle, see if students can find the arc length of a  $30^\circ$  portion of the circle ( $\frac{3\pi}{3} = \pi$ ). Then, ask students what portion of the total circumference  $\pi$  is.  $\pi$  is  $\frac{1}{12}$  of  $12\pi$ , just like  $30^\circ$  is  $\frac{1}{12}$  of  $360^\circ$ . This should lead students towards the Arc Length Formula.

Students may wonder why it is necessary to leave answer in exact value, in terms of  $\pi$ , instead of approximate (multiplying by 3.14). This is usually a teacher preference. By using the approximate value for  $\pi$ , the answer automatically has a rounding error. Rounding the decimal too short will cause a much larger error than using the decimal to the hundred-thousandths place. Whatever your preference, be sure to explain both methods to your students. The review questions request that answers be left in terms of  $\pi$ , but this can be easily changed, depending on your decision.

---

## Area of Circles and Sectors

### Goal

This lesson reviews the formula for the area of a circle and introduces the formula for the area of a sector and segment of a circle.

### Teaching Strategies

If you have access to an LCD display or a computer lab, show students the animation of the area of a circle formula (link is in the FlexBook).

The formula for the area of a sector is very similar to the formula for arc length. Ask students to compare the two formulas. Stress to students that the angle fraction in the sector formula is the same as it is for the arc length formula. Therefore, students do not need to memorize a new formula; they just need to remember the angle fraction for both.

To find the area of the shaded regions (like Example 8), students will need to add or subtract areas of circles, triangles, rectangles, or squares in order to find the correct area. Encourage students to identify the shapes in these types of problems before they begin to solve it. At the end of this lesson, quickly go over problems 23-25, so that students know how to solve the problems that evening. Remind students to use the examples in the lesson to help them with homework problems.

Finding the area of a segment can be quite challenging for students. This text keeps the angles fairly simple, using special right triangle ratios. Depending on your level of student, you may decide to omit this portion of this lesson. If so, skip Example 9 and review questions 26-31.

**Additional Example:** Find the area of the blue shaded region below.

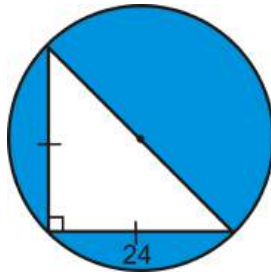

**Solution:** The triangle that is inscribed in the circle is a 45-45-90 triangle and its hypotenuse is on the diameter of the circle. Therefore, the hypotenuse is  $24\sqrt{2}$  and the radius is  $12\sqrt{2}$ . The area of the shaded region is the area of the circle minus the area of the triangle.

$$A_{\odot} = \pi(12\sqrt{2})^2 = \pi \cdot 144 \cdot 2 = 288\pi$$

$$A_{\Delta} = \frac{1}{2} \cdot 24 \cdot 24 = 288$$

The area of the shaded region is  $288\pi - 288 \approx 616.78 \text{ units}^2$

## 1.11 Surface Area and Volume

### Pacing

TABLE 1.16:

<b>Day 1</b> <i>Exploring Solids</i>	<b>Day 2</b> <i>Surface Area of Prisms &amp; Cylinders</i>	<b>Day 3</b> <i>Finish Surface Area of Prisms &amp; Cylinders</i>	<b>Day 4</b> <b>Quiz 1</b> <i>Start Surface Area of Pyramids and Cones</i>	<b>Day 5</b> <i>Finish Surface Area of Pyramids and Cones</i>
<b>Day 6</b> <i>Volume of Prisms &amp; Cylinders</i>	<b>Day 7</b> <b>Quiz 2</b> <i>Start Volume of Pyramids &amp; Cones</i>	<b>Day 8</b> <i>Finish Volume of Pyramids &amp; Cones Investigation 11-1</i>	<b>Day 9</b> <i>Surface Area and Volume of Spheres</i>	<b>Day 10</b> <b>Quiz 3</b> <i>*Start Extension: Exploring Similar Solids</i>
<b>Day 11</b> <i>*Finish Extension: Exploring Similar Solids</i>	<b>Day 12</b> <b>*Extension Quiz</b> <i>Start Review of Chapter 11</i>	<b>Day 13</b> <i>Review of Chapter 11</i>	<b>Day 14</b> <b>Chapter 11 Test</b>	<b>Day 15</b> <b>Start Chapter 12</b>

### Exploring Solids

#### Goal

The purpose of this lesson is to introduce students to three-dimensional figures. Polyhedral figures are presented in this lesson and common terms such as edge, vertex, and face are explained, as well as how to name polyhedra.

#### Relevant Review

Students should know the definition of a regular polygon and how to find the area of various triangles and quadrilaterals.

#### Teaching Strategies

Like with previous chapters, it might be helpful for students to make flash cards of the vocabulary and theorems learned.

Discuss with students where they would see polyhedra, prisms, pyramids, cylinders, and cones in real life. Tell students to visualize themselves in a grocery store; there are several examples of these solids there. Examples could be: soup can (cylinder), Toblerone chocolate bar (triangular prism), oranges (sphere), or waffle cones (cone). Write down the items students come up with and draw a representation.

After going over Example 1 and putting the faces, vertices, and edges into a table, see if students can come up with Euler's Theorem on their own. Students might wonder why they need to know Euler's Theorem, when they can just count the number of vertices, edges, and faces. One application could be when the prism has so many sides that it becomes difficult to count the edges ( $E$  is always the largest of  $F, V$ , and  $E$  in the formula). Other applications are Examples 3 and 4, when you are not given a picture in the problem.

One way to “view” a three-dimensional solid is to use cross-sections. You might need to use physical models to help students understand this concept. For example, you could mold Play-doh into a cylinder or cube and “cut” them

in different ways to show the different cross-sections. A cylinder can have a circle, oval (or portion of an oval), or rectangle as a cross-section.

Another way to “view a three-dimensional solid is to use a net. A net takes all the faces of a solid and lies them out flat and adjoining. Students need to be careful with nets. There can be several answers for one solid and depending on how the faces are laid out, the net might not even work. Be sure to show students nets that do not work. The activity in the link, <http://illuminations.nctm.org/activitydetail.aspx?ID=84>, gives students 20 possible nets of a cube and they need to find the 11 that work.

## Surface Area of Prisms and Cylinders

### Goal

Students will learn how to find the surface area of prisms and cylinders.

### Relevant Review

Students should know how to find a net of a three-dimensional solid. They will also need to be able to find the area of triangles and quadrilaterals.

### Teaching Strategies

The surface area can be difficult for students to visualize. Make sure they have a firm grasp on how to find nets of a three-dimension figure. Students need to find all the lengths and heights of the faces of a prism before finding the total surface area. For example, in Example 2, students need to find the length of the hypotenuse of the base because it is also the length of a rectangle.

**Additional Example:** Find the surface area of the trapezoidal prism. The bases are isosceles trapezoids.

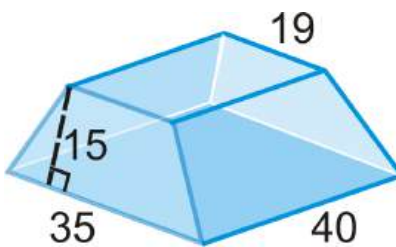

**Solution:** First find the length of the legs of the isosceles trapezoid bases.

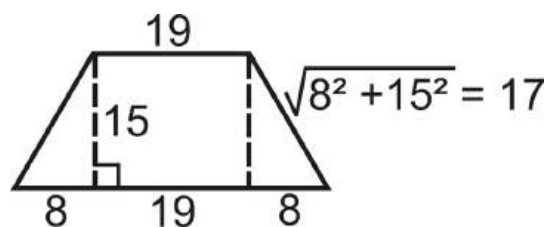

Here is the net for this prism.

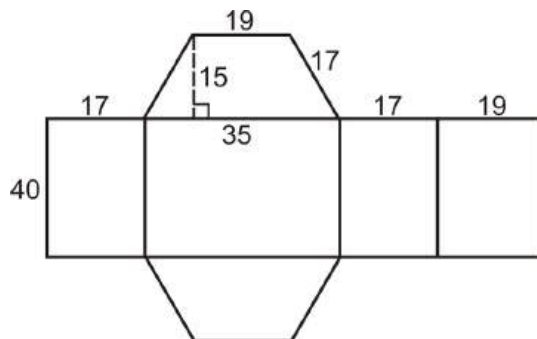

### Surface Area:

$$\text{Trapezoids } A = \frac{1}{2}(35 + 19)15 = 405$$

$$\text{Rectangles } A = 17 \cdot 40 = 680$$

$$A = 35 \cdot 40 = 1400$$

$$A = 19 \cdot 40 = 760$$

$$\begin{aligned} \text{Total} &= 405 + 405 + 680 + 680 + 1400 + 760 \\ &= 4330 \text{ units}^2 \end{aligned}$$

The surface area of a cylinder can be difficult for students to visualize. As the FlexBook suggests, take the label off of a soup can so that it opens up to a rectangle. Then, students will see that the width of the rectangle is the circumference of the circular base.

---

## Surface Area of Pyramids and Cones

### Goal

Students will learn the formulas for the surface area of a regular pyramid and cone.

### Relevant Review

Students should review nets and the formula for the area of triangles and quadrilaterals. Students should also be able to apply the Pythagorean Theorem, Pythagorean triples, and special right triangle ratios.

### Teaching Strategies

The *slant height* is a new term that applies to the lateral faces. It is only used to find the surface area of pyramids and cones. Students may need to use the actual height to find the slant height through the Pythagorean Theorem. Help students develop a formula for finding the slant height for different types of pyramids and cones. In this lesson, we will find the surface area of equilateral triangle based pyramids, square based pyramids, and right cones.

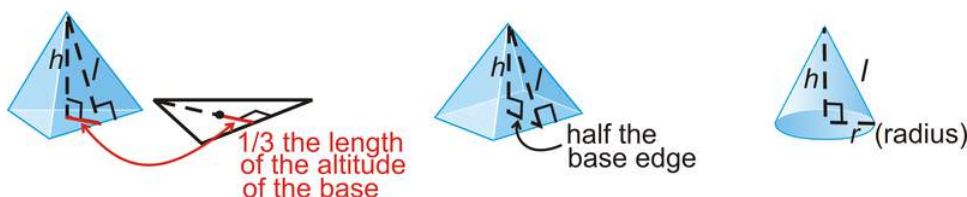

The most difficult of the three is the equilateral based pyramid. For the review questions in this section, the slant height for these pyramids is given. However, students will still need to find the altitude of the base in order to find

the area. Or, if students remember, they can use the formula,  $A = \frac{s^2\sqrt{3}}{4}$  for the area of any equilateral triangle, where  $s$  is the length of the sides.

Since students only need to worry about two types of pyramids (for surface area), then you could generate more specific surface area formulas for each one. They are:

$$\text{Equilateral triangle based pyramid : } SA = B + \frac{1}{2}nbl = \frac{s^2\sqrt{3}}{4} + \frac{1}{2}(3)sl = \frac{s^2\sqrt{3}}{4} + \frac{3}{2}sl$$

$$\text{Square based pyramid : } SA = B + \frac{1}{2}nbl = s^2 + \frac{1}{2}(4)sl = s^2 + 2sl$$

Where  $s$  is the edge length and  $l$  is the slant height. Once students know the basic surface area, derive these with the class for  $n = 3$  and  $n = 4$ .

Compared to the pyramid, the surface area of a cone is relatively simple. Students will always be given two of the three pieces of information needed;  $h$ ,  $r$ , or  $l$  (in the picture above). If the problem does not give  $l$ , the slant height, then students will have to use the Pythagorean Theorem to solve for it.

## Volume of Prisms and Cylinders

### Goal

Students will learn how to find the volume of prisms and cylinders. They will also discover that the volume of an oblique prism or cylinder is the same as a right prism or cylinder with the same height.

### Relevant Review

Students will still need to know how to find the area of triangles and quadrilaterals so they can properly apply the volume formulas in this lesson. Also, review with students how to “cube” and “cube root” a number. Lastly, review the definitions of prisms and cylinders, so students are clear about which faces are bases. This will be very helpful when using the volume formulas.

### Teaching Strategies

Begin with a discussion of volume. Students might get volume, mass, and density confused. Volume is simply the amount of physical space a three-dimension takes up. Think of two different objects that have the same shape; a 12-pound bowling ball and a plastic empty sphere of the same size. Both of these solids have the same volume, but very different masses or densities. Therefore, an empty solid has the same *volume* as a full solid of the same size.

Volume is measured in cubic units, or units<sup>3</sup>. This is because the formula for volume always comes back to  $length \times width \times height$ . Each of these have a unit associated with them. So, the answer would be  $unit \times unit \times unit = units^3$ .

Example 1 explores the concept of placing cubes (of whatever unit) into a prism to find its volume. Students can count all these cubes and find that there are 60 within the prism. Another option would be to show students what the area of each face is and then multiply that by the relative height. This will demonstrate that the order of multiplication does not matter.

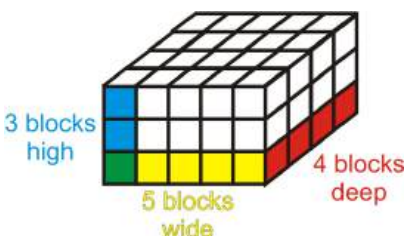



$$V = (3 \times 5) \times 4 = 15 \times 4 = 60$$

$$V = (3 \times 4) \times 5 = 12 \times 5 = 60$$

$$V = (5 \times 4) \times 3 = 20 \times 3 = 60$$

Regardless of the order, the formula for the volume of a rectangular prism will be  $length \times width \times height$ . It does not matter which face is the base for a rectangular prism.

Students will take the words “base” and “height” literally. However, in the formula for volume, the “height” might not always be the vertical length. As in Example 3, the apparent height of the solid is only the height of the base. The “height” in the formula is actually 7 ft, which looks like the length of the base. Students will think that the base of this tent is the rectangle on the bottom. However, we know that the bases are actually the triangles at the front and back of the tent. Be very careful when discussing the formula for volume and the definition of a prism. Review with students that the “bases” are the two congruent parallel faces. Before starting on a volume problem, students should examine the solid so they know which faces are the bases.

As with the case of an oblique prism, the sides are all parallelograms, however the bases will still be parallel. Students should know that the height of an oblique prism is not going to be an edge (like it is in a right prism), but a vertical length that is outside the solid. Review with students that the base of a cylinder is a circle.

## Volume of Pyramids and Cones

### Goal

In this lesson, students will discover that the volume of a pyramid is one-third the volume of a prism with the same base. This property also applies to cones. Then, they will find the volume of composite solids.

### Relevant Review

Make sure students are comfortable finding the volume of prisms and cylinders from the previous lesson.

### Teaching Strategies

Investigation 11-1 should be a teacher-led activity. You should pre-make the open nets of a cube and pyramid and then demonstrate that filling the pyramid three times will completely fill the cube.

If you decide to allow students to do the investigation, be prepared for it to take 20-30 minutes. You should make the nets with students in case they have questions. Have students complete this activity in pairs and each student in the pair can make one net.

In this lesson, students should be able to find the volume of any triangle or quadrilateral based pyramid and any type of cone. If students are ever given the slant height, they will need to solve for the overall height of the pyramid or cone. If a cone is not a right cone, it will not have a slant height and students will need to be given the height in order to find the volume.

Like with surface area of pyramids, you can generate more specific formulas for the volume of an equilateral triangle based pyramid and a square based pyramid. They would be:

$$\text{Equilateral triangle based pyramid :} \quad V = \frac{1}{3}Bh = \frac{1}{3} \left( \frac{s^2 \sqrt{3}}{4} \right) h = \frac{s^2 h \sqrt{3}}{12}$$

$$\text{Square based pyramid :} \quad V = \frac{1}{3}Bh = \frac{1}{3}s^2 h$$

$s$  and  $h$  are the base edge length and the height. You can also generate formulas for the volume of a rectangular based pyramid and a right triangle based pyramid.

Problems 3 and 6 will be quite difficult for students to complete (in the Review Questions). This is because the bases are equilateral triangles and they are given the slant height. If you desire, you can change the values given as the slant height to be the height of the pyramids. If you do this, the answers will be  $\frac{256\sqrt{3}}{3}$  and  $240\sqrt{3}$ , respectively. Students will still need to find the area of the equilateral triangle bases  $\left(\frac{s^2\sqrt{3}}{4}\right)$ . If you do not alter the problems, students will have to find the height of the pyramids, using the slant height. This will be a difficult process, because students will have to recall the properties of the centroid (the point where the vertical height hits the base). Therefore, the distance from the bottom of the slant height to the centroid will be one-third the length of the entire altitude. (See the picture in the teaching tips for Surface Area of Pyramids and Cones.)

---

## Surface Area and Volume of Spheres

### Goal

Students will learn how to find the surface area and volume of spheres and hemispheres.

### Relevant Review

Make sure students are comfortable with the formulas for circumference and area of a circle. Also, students will apply the formulas for the surface area and volume of cylinders and cones to composite solids.

### Teaching Strategies

Ask students where they have seen spheres and hemispheres in real life. Discuss the parts of a sphere that are the same as a circle and those parts that are different. Be sure to show students the animated derivations of the surface area and volume by Russell Knightley.

<http://www.rkm.com.au/ANIMATIONS/animation-Sphere-Surface-Area-Derivation.html>

<http://www.rkm.com.au/ANIMATIONS/animation-Sphere-Volume-Derivation.html>

When finding the surface area or volume of composite solids discuss with students what the parts are before starting each problem. This will make it easier for students to complete the problem. Also, make sure they understand when to not include the top or bottom of cylinders or hemispheres in the total surface area (see Example 5).

---

## Extension: Exploring Similar Solids

### Goal

Students will understand the relationship between similar solids, their surface areas, and their volumes.

### Relevant Review

The areas of similar polygons should be reviewed before starting this extension. Students should know that the square of the scale factor is the ratio of the areas of two similar shapes.

### Teaching Strategies

Help students make the connection between the ratios of the areas of two similar shapes is the same as the ratio of the surface areas of two similar solids. Both are area, so both ratios will be the square of the scale factor. Following this pattern, ask students if they have an idea as to what the ratio of the volumes of two similar solids would be.

**Additional Example:** The two square based pyramids below are similar. Find the surface area and volume of both

solids.

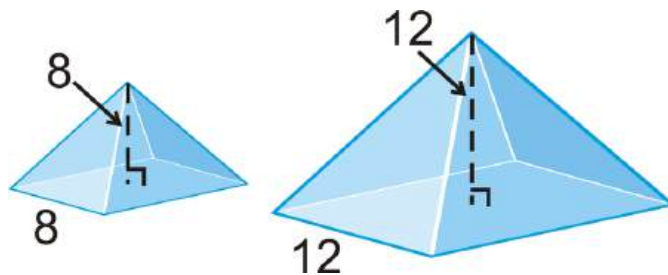

**Solution:** The scale factor is  $\frac{8}{12} = \frac{2}{3}$ . The slant height of the smaller pyramid is  $l = \sqrt{4^2 + 8^2} = \sqrt{16 + 64} = \sqrt{80} = 4\sqrt{5}$ . Using the scale factor, the slant height of the larger pyramid is  $\frac{3}{2} \cdot 4\sqrt{5} = 6\sqrt{5}$ .

$$SA_{\text{smaller}} = 8^2 + 4 \left( \frac{1}{2} \cdot 8 \cdot 4\sqrt{5} \right) = 64 + 64\sqrt{5}$$

$$V_{\text{smaller}} = \frac{1}{3}(8^2)8 = \frac{512}{3}$$

$$SA_{\text{larger}} = 12^2 + 4 \left( \frac{1}{2} \cdot 12 \cdot 6\sqrt{5} \right) = 144 + 144\sqrt{5}$$

$$V_{\text{larger}} = \frac{1}{3}(12^2)12 = 576$$

Encourage students to find the ratios of the surface areas and volumes above to reinforce what was learned in this lesson.

## 1.12 Rigid Transformations

### Pacing

TABLE 1.17:

<b>Day 1</b> <i>Exploring Symmetry</i>	<b>Day 2</b> <i>Translations</i>	<b>Day 3</b> <i>Reflections</i>	<b>Day 4</b> <b>Quiz 1</b> <i>Start Rotations</i> <i>Investigation 12-1</i>	<b>Day 5</b> <i>Finish Rotations</i>
<b>Day 6</b> <i>Compositions of Transformations</i> <i>Investigation 12-2</i>	<b>Day 7</b> <b>Quiz 2</b> <i>*Extension: Tessellating Polygons</i>	<b>Day 8</b> <b>*Extension Quiz</b> <i>Start Review of Chapter 12</i>	<b>Day 9</b> <i>Finish Review of Chapter 12</i>	<b>Day 10</b> <b>Chapter 12 Test</b>

### Exploring Symmetry

#### Goal

This lesson introduces line symmetry and rotational symmetry.

#### Teaching Strategies

The Know What? for this lesson provides a good starting point for a discussion about symmetry in nature. After defining line symmetry and rotational symmetry, discuss how both are found in nature and the real world. Then, go over the symmetry in the starfish.

Have your students write the alphabet in uppercase letters. Using one colored pencil, show which letters possess horizontal or vertical symmetry by drawing in the line. For example, *B*, *E*, and *K* have a line of horizontal symmetry. Using a second color, draw in the vertical lines of symmetry. Have a contest to determine who can write the longest word possessing one type of symmetry. For example, MAXIMUM is a word where all the letters have vertical symmetry. KICKBOXED has a horizontal line of symmetry. You could even do words like TOT. The entire word has vertical symmetry.

When discussing rotational symmetry, some textbooks may refer to the rotations as *n-fold* rotational symmetry. This simply means that the *n* is the number of times the figure can rotate onto itself. For example, a regular pentagon has 5-fold rotation symmetry, because it can be rotated 5 times of  $108^\circ$  before returning to its original position.

### Translations

#### Goal

The purpose of this lesson is to introduce the concept of translations in the coordinate plane.

#### Relevant Review

Students should be comfortable with the distance formula and finding the slope between two points.

#### Teaching Strategies

All the transformations in this chapter are rigid transformations or isometries. Students need to know that these transformations never change the size or shape of the preimage and, therefore, will always create congruent images.

A “translation rule” is not properly defined in this lesson. A translation rule is the amount an image is translated (or moved) from the preimage. A rule can only be applied when the translation is in the coordinate plane. The horizontal movement is added or subtracted from  $x$  and the vertical movement is added or subtracted from  $y$ . The horizontal and vertical change will always be the same for every point in a figure. For example, if the translation rule is  $(x,y) \rightarrow (x+1,y-2)$  for a triangle, each vertex of the triangle will be moved to the right one unit and down two units.

### Additional Example:

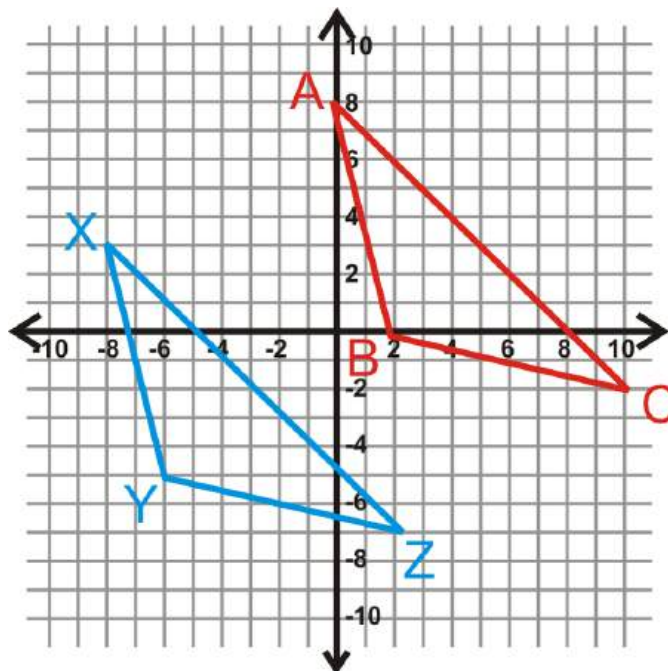

a) If  $\triangle ABC$  is the preimage, find the translation rule for image  $\triangle XYZ$ .

b) If  $\triangle XYZ$  is the preimage, find the translation rule for image  $\triangle ABC$ .

### Solution:

a) From  $A$  to  $X$ , the triangle is translated to the *left* 8 units and *down* 5 units.  $(x,y) \rightarrow (x-8,y-5)$ .

b) From  $X$  to  $A$ , the triangle is translated to the *right* 8 units and *up* 5 units.  $(x,y) \rightarrow (x+8,y+5)$ .

## Reflections

### Goal

Students will reflect a figure over a given line and find the rules for reflections over vertical and horizontal lines in the coordinate plane.

### Teaching Strategies

Using patty paper (or tracing paper), have students draw a small scalene triangle  $\triangle ABC$  on the right side of the paper. Fold the paper so that  $\triangle ABC$  is covered and then trace it. Unfold the patty paper and label the vertices as  $A'$ ,  $B'$ , and  $C'$ , the images of  $A$ ,  $B$ , and  $C$ . Darken the fold line; this is the line of reflection. Use a ruler to draw  $\overline{AA'}$ . Mark

the intersection of the reflecting line and  $\overline{AA'}$  point  $M$ . Find  $AM$  and  $A'M$ . Ask students what they notice about the distances and how the line  $\overline{AA'}$  intersects the line of reflection.

Students might have a hard time visualizing where a reflection should be placed. Tell students to use the activity described above to help them. They can fold their graph paper on the appropriate line (the  $y$ -axis, for example) and then trace the figure on the other side. Until they get used to using the rules, this can be one way for students to apply a reflection.

One way to help students remember the rules for reflections over vertical or horizontal is that the other coordinate is changed. For a reflection over the  $x$ -axis (or horizontal line), the  $x$ -value will stay the same and the  $y$ -value will change. For a reflection over the  $y$ -axis (or vertical line), the  $y$ -value will stay the same and the  $x$ -value will change. The new coordinates of an image depend on how far away the preimage points are. If a point is 5 units to the left of a line of reflection, then the image will be 5 units to the right of the line of reflection.

The only diagonal lines that we will reflect over in this chapter are  $y = x$  and  $y = -x$ . Again, encourage students to fold their graph paper when starting rotations over these lines and completing homework or class work problems.

## Rotations

### Goal

In this lesson, students will learn about general rotations and in the coordinate plane. By the end of the lesson, students should be able to apply the rules of rotation for  $90^\circ$ ,  $180^\circ$ , and  $270^\circ$ , as well as draw a rotation (using a protractor) of any degree.

### Relevant Review

Make sure students remember how to draw and measure an angle, using a protractor. Practice this before starting Investigation 12-1.

### Teaching Strategies

Investigation 12-1 should be done individually by each student. The teacher can also lead the students in the activity, on the overhead projector, if desired. Students need to be comfortable rotating a figure around a fixed point. Every student will need a protractor for this activity. After completing the investigation, have students repeat it with another figure of their choosing. Encourage students to pick a figure that has straight sides, such as a quadrilateral or the letters  $H$ ,  $T$ , or  $E$ .

Unless otherwise stated, rotations are always done in a counterclockwise direction. Tell students this is because the quadrants are numbered in a counterclockwise direction. In the coordinate plane, the origin is always the center of rotation.

After going over the rules for the rotations of  $90^\circ$ ,  $180^\circ$ , and  $270^\circ$ , compare the rules learned in the previous lesson to these (reflections over the  $x$  and  $y$  axis and  $y = x$  and  $y = -x$ ). At this point, students know seven different reflection and rotation rules that are all very similar.

Reflection over  $x$ -axis:  $(x, y) \rightarrow (x, -y)$

Reflection over  $y$ -axis:  $(x, y) \rightarrow (-x, y)$

Reflection over  $y = x$ :  $(x, y) \rightarrow (y, x)$

Reflection over  $y = -x$ :  $(x, y) \rightarrow (-y, -x)$

Rotation of  $90^\circ$ :  $(x, y) \rightarrow (-y, x)$

Rotation of  $180^\circ$ :  $(x, y) \rightarrow (-x, -y)$

Rotation of  $270^\circ$ :  $(x, y) \rightarrow (y, -x)$

### 1.12. RIGID TRANSFORMATIONS

All of these rules are different, but very similar. It is encouraged that students make flash cards for this rules to help them memorize each one. Ask students which ones have the  $x$  and  $y$  values switched and why they think that is. Also, see if they can make a correlation between the reflections over the  $x$  and  $y$  axis and the rotation of  $180^\circ$ . These three are the only rules where there is just a sign change. As it will be seen in the next chapter, a rotation of  $180^\circ$  is a composition of the double reflection over the axes. Students might be able to notice this by looking at the rules now. The reflection over the  $x$ -axis has a negative  $y$  and the reflection over the  $y$ -axis has a negative  $x$ . In the rotation of  $180^\circ$ , both  $x$  and  $y$  are negative.

## Composition of Transformations

### Goal

This lesson introduces students to the concept of composition. Composition is the process of applying two (or more) operations to an object. In this lesson, we will only apply two transformations to an object and then determine what one transformation this double-translation is the same as.

### Teaching Strategies

Students can get easily confused when applying compositions. They may attempt to perform the composition from left to right, as in reading a sentence. Point out to the students they must begin with the object and, according to the order of operations, should perform the operation occurring within the parentheses first. A glide reflection is the only composition where order does not matter.

Have students do Example 6 and see if they can come up with the Reflection over the Axes Theorem on their own. You may need to do an additional example so students see the pattern.

**Additional Example:** Reflect  $\triangle XYZ$  over the  $y$ -axis and the  $x$ -axis. Find the coordinates of  $\triangle X''Y''Z''$  and the one transformation this double reflection is the same is.

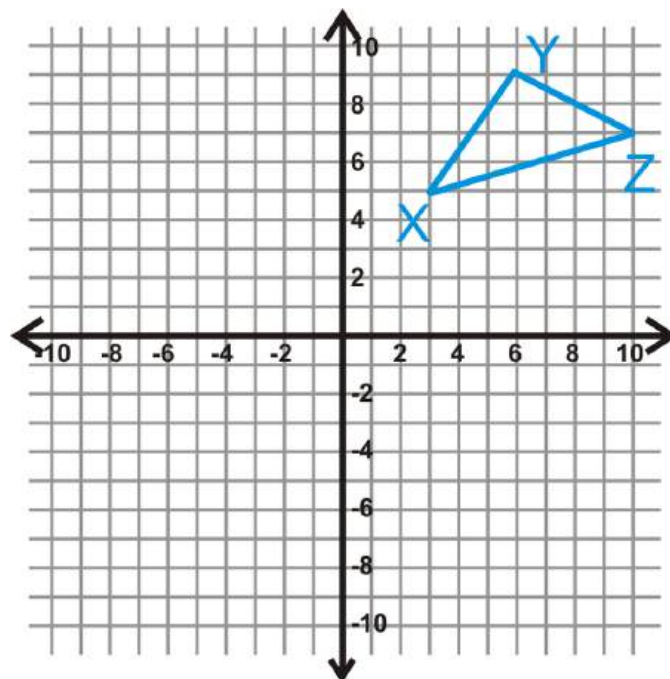

**Solution:** The coordinates of  $\triangle XYZ$  and  $\triangle X''Y''Z''$  are:

$$X(3,5) \rightarrow X''(-3,-5)$$

$$Y(6,9) \rightarrow Y''(-6,-9)$$

$$Z(10,7) \rightarrow Z''(-10,-7)$$

From these coordinates, we see that a double reflection over the  $x$  and  $y$  axes is the same as a rotation of  $180^\circ$ .

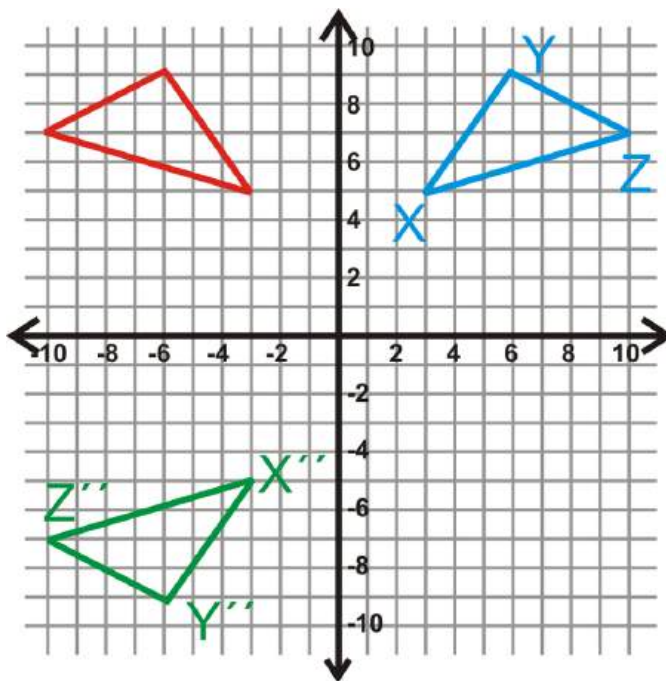

Investigation 12-2 should be a teacher-led activity. You can either have students perform the investigation along with you or you can just do the activity and have student write down the necessary information.

## Extension: Tessellating Polygons

### Goal

This lesson defines tessellations and shows students how to create a tessellation from regular polygons.

### Relevant Review

Review with students the definition of a regular polygon and how many degrees are in a quadrilateral, pentagon, hexagon, octagon, etc.

### Teaching Strategies

Take students to the computer lab and let them play with the Tessellation Artist, from the website given in the Flex-Book (<http://www.mathisfun.com/geometry/tessellation-artist.html>). This website does not create true tessellations, but it is fun for students to see if or how their drawing would tessellate.

Students may wonder if shapes other than regular polygons tessellate. You can show them the example below and then see if they can tessellate any quadrilateral. When tessellating this quadrilateral, make sure that every student has a different quadrilateral. When everyone is done, have the students hold up their tessellations or share them with each other.

**Additional Example:** Tessellate the quadrilateral below.

## 1.12. RIGID TRANSFORMATIONS



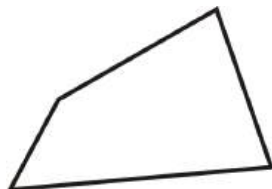

**Solution:** To tessellate any image you will need to reflect and rotate the image so that the sides all fit together. First, start by matching up the each side with itself around the quadrilateral.

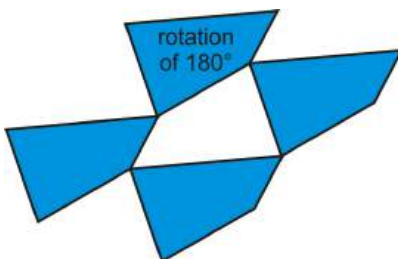

Now, continue to fill in around the figures with either the original or the rotation.

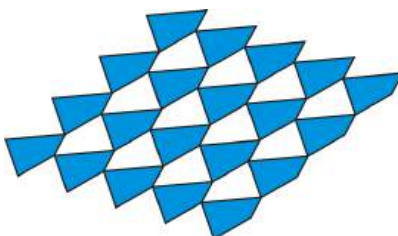

This is the final tessellation. You can continue to tessellate this shape forever.

---

**CHAPTER 2****Basic Geometry TE -  
Common Errors****CHAPTER OUTLINE**

---

- 2.1 BASICS OF GEOMETRY**
  - 2.2 REASONING AND PROOF**
  - 2.3 PARALLEL AND PERPENDICULAR LINES**
  - 2.4 TRIANGLES AND CONGRUENCE**
  - 2.5 RELATIONSHIPS WITH TRIANGLES**
  - 2.6 POLYGONS AND QUADRILATERALS**
  - 2.7 SIMILARITY**
  - 2.8 RIGHT TRIANGLE TRIGONOMETRY**
  - 2.9 CIRCLES**
  - 2.10 PERIMETER AND AREA**
  - 2.11 SURFACE AREA AND VOLUME**
  - 2.12 RIGID TRANSFORMATIONS**
-

## 2.1 Basics of Geometry

### Points, Lines and Planes

**Naming Lines** - Students often want to use all the labeled points on a line in its name, especially if there are exactly three points labeled. Tell them they get to pick two, any two, to use in the name. This means there are often many possible correct names for a single line.

Practice Exercise : How many different names can be written for a line that has four labeled points?

Answer : 12, Students can get to this answer by listing all the combinations of two letters. Recommend that they make the list in an orderly way so they do not leave out any possibilities. This exercise is good practice for counting techniques learned in probability.

**Naming Rays** - There is so much freedom in naming lines that students often struggle with the precise way in which rays must be named. It is helpful to think of the name of a ray as a starting point and direction. There is only one possible starting point, but often several points that can indicate direction. Any point on the ray other than the endpoint can be the second point in the name. The “ray” symbol drawn above the two points should be drawn such that the endpoint is over the endpoint of the ray and the arrow is over the second point which indicates the direction.

Example: The ray to the right could be named  $\overrightarrow{AB}$  or  $\overrightarrow{AC}$



**There is only one point B** - English is an ambiguous language. Two people can have the same name; one word can have two separate meanings. Math is also a language, but is different from other languages in that there can be no ambiguity. In a particular figure there can be only one point  $B$ . A point marks a location and a diagram is like a map. If you have multiple streets with the same name, it is impossible to distinguish between them and find a particular address. Students also need to be reminded that points should always be labeled with capitol letters.

**Coplanar Points** - Students are often confused by the phrase “three non-collinear points” are necessary to define a plane. They think that none of the points can be on the same line but in reality there is a line through any two points. It must be made clear that the phrase “three non-collinear points” implies that all three of the points are not on the same line but that any two of them may be collinear.

**Intersections** - Visualizing geometric figures and their intersections can be very difficult for students. Sometimes it helps to use a pencil and paper to illustrate the difference between a line intersecting a plane and a line in a plane. Objects in the room or parts of the building can be used to visualize two planes intersecting in a line (a wall and the ceiling) or three planes intersecting in a point (two walls and the floor). Many high school students still struggle with visualizing these abstract concepts, the more they can be realized in everyday objects, the better students will understand them.

---

## Segments and Distance

**Using a Ruler** - Many Geometry students need to be taught how to use a ruler. The problems stems from students not truly understanding fractions and decimals. This is a good practical application and an important life skill. Measuring in centimeters will be learned quickly. Give a brief explanation of how centimeters and millimeters are marked on the ruler. Since a millimeter is a tenth of a centimeter, both fractions and decimals of centimeters are easily written. Students need to practice using a ruler and recognizing centimeters, millimeters and inches. It is very common for students to measure incorrectly, particularly when using inches because they have difficulty interpreting the fractional divisions of inches on a ruler. Some may need to be shown how an inch is divided using the marks for  $\frac{1}{2}$ ,  $\frac{1}{4}$ ,  $\frac{1}{8}$  and  $\frac{1}{16}$ . These fractions often need to be added and reduced to get a measurement in inches.

Another difficulty students encounter is inaccurate measuring because they used the edge of the ruler rather than the mark at zero. Example 1 in the textbook illustrates the correct way to line up the ruler with a segment and the diagram which follows this example shows how to read the partial inches and centimeters on the ruler.

**Number or Object** - The measure of a segment is a number that can be added, subtracted and combined arithmetically with other numbers. The segment itself is an object to which postulates and theorems can be applied. Using the correct notation may not seem important to the students, but is a good habit that will work to their benefit as they progress in their study of mathematics. For example, in calculus whether a variable represents a scalar or a vector is critical. To be sure students can differentiate between the two concepts, emphasize the notation for the **measure of  $\overline{AB}$**  - Students really struggle with the difference in meaning of  $\overline{AB}$ ,  $m\overline{AB}$  and  $AB$ . The first one,  $\overline{AB}$ , refers to the object, the segment with endpoints  $A$  and  $B$ . The latter two expressions refer to the length of the segment and/or the distance from  $A$  to  $B$  and may be used interchangeably.

**Segment Addition** - Students should be encouraged to always make a sketch of the segment with particular endpoints and the point between them. Having this concrete diagram will help them avoid setting up an incorrect equation. The process of going from a description to a picture also helps them review their vocabulary. One common mistake with these problems is that once students have been presented with the example in which the point on the segment is the midpoint they sometimes think that the point on the segment in all subsequent examples is also a midpoint. It is important to help them read the questions carefully and note terms such as “in the middle” which indicates a midpoint and “in between” which does not indicate a midpoint.

**Review the Coordinate Plane and Horizontal and Vertical Distance** - Some students will have forgotten how to graph an ordered pair on the coordinate plane, or will get the words vertical and horizontal confused. A reminder that the  $x$ -coordinate is first, and measures horizontal distance from the origin, and that the  $y$ -coordinate is second and measures vertical distance from the origin will be helpful. The coordinates are listed in alphabetical order. When counting these distances on the coordinate plane students occasionally will count the starting point as one and thus end up with a length that is one unit more than the actual distance. Comparing this to when they are playing a board game and counting off squares as they move their token (you don't count the square you start on as one), or counting laps as they run around the track (you don't count one until you've completed the first lap) may give them a couple of real world example to which they can relate an otherwise abstract concept.

---

## Angles and Measurement

**Naming Angles with Three Points** - Naming and identifying angles named with three points is often challenging for students when they first learn it. The middle letter of the angle name, the vertex of the angle, is the most important point. Instruct the students to start by identifying this point and working from there. Remind students that an angle is made up of two rays and that the three points used to identify the angle come directly from these two rays. With practice students will become adept at seeing and naming different angles in a complex picture. Review of this concept is also important. Every few months give the students a problem that requires using this important skill. It

can be difficult for students to learn all of the different notations and labeling practices, especially in the beginning, but practicing these skills will help build a strong foundation for students in geometry. It is crucial that they can read, correctly interpret and correctly communicate in this language in order to be successful in this course.

**Using a Protractor** - Students need to be shown how to line up the vertex and side of the angle correctly with the protractors available for their use. Not all protractors are the same and students often struggle with this procedure, particularly if the protractor the teacher is using is different from theirs. It is worth taking the time to check with each student to make sure they know how to use their own protractor. The two sets of numbers on a protractor are convenient for measuring angles oriented in many different directions, but often lead to errors on the part of the students. There is a simple way for students to check their work when measuring an angle with a protractor. Visual inspection of an angle usually can be used to tell if an angle is acute or obtuse. After the measurement is taken, students should notice if their answer matches with the classification. In fact, encouraging students to always consider whether their answers are reasonable is a good practice to encourage. Students don't think to do this and often make a small error in calculation that leads to an answer that is clearly wrong. They can help themselves be more accurate in their work if they learn to embrace this habit.

**Marking Segments and Angles** - Students need to be able to interpret these markings and use them to communicate which angles and segments are congruent and which are not in their own diagrams. It is imperative to practice these skills with students to avoid confusion later in the course.

---

## Midpoints and Bisectors

**Congruent or Equal** - Frequently students interchange the words congruent and equal. Stress that equal is a word that describes two numbers, and congruent is a word that describes two geometric objects. Equality of measure is often one of the conditions for congruence. If the students have been correctly using the naming conventions for a segment and its measure and an angle and its measure in previous lessons they will be less likely to confuse the words congruent and equal now.

**The Number of Tick Marks or Arcs Does Not Give Relative Length** - A common misconception is that a pair of segments marked with one tick, are longer than a pair of segments marked with two ticks in the same figure. Clarify that the number of ticks just groups the segments; it does not give any relationship in measure between the groups. An analogous problem occurs for angles.

**Midpoint or Bisector** - Midpoint is a location, a noun, and bisect is an action, a verb. One geometric object can bisect another by passing through its midpoint. This link to English grammar often helps students differentiate between these similar terms.

**Intersects vs. Bisects** - Many students replace the word intersects with bisects. Remind the students that if a segment or angle is bisected it is intersected, and it is know that the intersection takes place at the exact middle.

**Orientation Does Not Affect Congruence** - The only stipulation for segments or angles to be congruent is that they have the same measure. How they are twisted or turned on the page does not matter. This becomes more important when considering congruent polygons later, so it is worth making a point of now.

**Labeling a Bisector or Midpoint** - Creating a well-labeled picture is an important step in solving many Geometry problems. How to label a midpoint or a bisector is not obvious to many students. It is often best to explicitly explain that in these situations, one marks the congruent segments or angles created by the bisector.

**Midpoint Formula** - Students often have a hard time remembering this formula. It helps to make the connection between a midpoint and the "averages" of the  $x$  and  $y$  coordinates. Students frequently use subtraction rather than addition in this formula and connecting the formula to finding an average helps them to remember that it should be addition. It is also important to remind students that the result is a point, a pair of coordinates and thus it should be written this way.

---

## Angle Pairs

**Complementary or Supplementary** - The quantity of vocabulary in Geometry is frequently challenging for students. It is common for students to interchange the words complementary and supplementary. There are several ways to help students remember which is which. One is to tell students that it is always *right to compliment* someone and thus complementary angles add up to 90 degrees or could form a right angle. Another way to remember that complementary angles add up to 90 degrees is to connect the first letter of the word complementary to the first letter of the term corner-typically a corner of a piece of paper is a 90 degree angle. It is also important to present students with examples of each of these pairs of these angles that are separate and adjacent. It is very easy for students to get in the habit of expecting these pairs of angles to occur one way or the other.

**Linear Pair and Supplementary** - All linear pairs have supplementary angles, but not all supplementary angles form linear pairs. Linear pairs are always adjacent pairs of supplementary angles but not all pairs of supplementary angles are adjacent. Understanding how Geometry terms are related helps students remember them. Linear pairs are a subset of pairs of supplementary angles.

**Angles formed by Two Intersecting Lines** - Students frequently have to determine the measures of the four angles formed by intersecting lines. They can check their results quickly when they realize that there will always be two sets of congruent angles, and that angles that are not congruent must be supplementary. They can also check that all four angles measures have a sum of 360 degrees.

**Write on the Picture** - In a complex picture that contains many angle measures which need to be found, students should write angle measures on the figure as they find them. Once they know an angle they can use it to find other angles. When students don't write each angle measure on the diagram they often overlook a relationship between angles that helps them find another measure. It is easy for them to think that they should only find the measures of the angles which are asked for in the problem, when in fact it may be helpful or even necessary to find other, unmarked, angles in the process. This may require them to draw or trace the picture on their paper. It is worth taking the time to do this. The act of drawing the picture will help them gain a deeper understanding of the angle relationships.

**Proofs** - The word proof strikes fear into the heart of many Geometry students. It is important to define what a mathematical proof is, and let the students know what is expected of them regarding each proof.

Definition: A mathematical proof is a mathematical argument that begins with a truth and proceeds by logical steps to a conclusion which then must be true.

The students' responsibilities regarding each proof depend on the proof, the ability level of the students, and where in the course the proof occurs. Some options are (1) The student should understand the logical progression of the steps in the proof. (2) The student should be able to reproduce the proof. (3) The student should be able to create proofs using similar arguments.

---

## Classifying Polygons

**Vocabulary Overload** - Students frequently interchange the words isosceles and scalene. This would be a good time to make flashcards. Each flashcard should have the definition in words and a marked and labeled figure. Just making the flashcards will help the students organize the material in their brains. The flashcards can also be arranged and grouped physically to help students remember the words and how they are related. For example, have the students separate out all the flashcards that describe angles. The cards could also be arranged in a tree diagram to show subsets, for instance equilateral would go under isosceles, and all the triangle words would go under the triangle card.

**Angle or Triangle** - Both angles and triangles can be named with three letters. The symbol in front of the letters determines which object is being referred to. Remind the students that the language of Geometry is extremely precise

and little changes can make a big difference.

**Acute Triangles need all Three** - A student may see one acute angle in a triangle and immediately classify it as an acute triangle. Remind the students that unlike the classifications of right and obtuse, for a triangle to be acute all three angles must be acute.

**Equilateral Subset of Isosceles** - In many instances one term is a subset of another term. A Venn diagram is a good way to illustrate this relationship. Having the students practice with this simple instance of subsets will make it easier for the students to understand the more complex situation when classifying quadrilaterals. It is also important to point out that these subsets are determined by properties exhibited in a figure. In this case, an Equilateral triangle possesses all of the characteristics or properties of an isosceles triangle plus additional properties which make it a subset of the Isosceles triangle category.

#### **Additional Exercises:**

1. Draw and mark an isosceles right and an isosceles obtuse triangle.

Answer: The congruent sides of the triangles must be the sides of the right or obtuse angle.

This exercise lays the groundwork for studying the relationship between the sides and angles of a triangle in later chapters. It is important that students take the time to use a straightedge and mark the picture. Using and reading the tick marks correctly helps the students think more clearly about the concepts.

**Vocab, Vocab, Vocab** - If the students do not know the vocabulary well, they will have no chance at learning the concepts and doing the exercises. Remind them that the first step is to memorize the vocabulary. This will take considerable effort and time. The student edition gives a good mnemonic device, “caving in” for remembering the word concave. Ask the students to create tricks to memorize other words and have them share their ideas.

**Side or Diagonal** - A side of a polygon is formed by a segment connecting consecutive vertices, and a diagonal connects nonconsecutive vertices. This distinction is important when students are working out the pattern between the number of sides and the number of vertices of a polygon. It is also worth noting that all diagonals in a convex polygon are inside the figure and at least one diagonal in a concave polygon lies outside the polygon. This is an additional method to distinguish between concave and convex polygons.

**Squaring in the Distance Formula** - After subtracting in the distance formula, students will need to square the result. This result is often a negative number. Remind them that the square of a negative number is a positive number. After the squaring step there should be no negatives or subtraction. If they have a negative in the square root, they have made a mistake.

## 2.2 Reasoning and Proof

### Inductive Reasoning

**Process of Inductive Reasoning** - Students often struggle with the concept of inductive reasoning. It is important to emphasize the three steps of the process: making observations, recognizing a pattern and forming a conjecture. Use real life examples, such as the following:

On Monday the principal decided to play classical music in the cafeteria during lunch. He measured the volume of noise in during lunch and determined it was 80 decibels. On Tuesday he played no music and the volume was 90 decibels. On Wednesday he played pop music and the volume was 85 decibels. The principal repeated this pattern of alternating classical music, no music and pop music a couple more times and noticed similar results. He concludes that classical music reduces the volume of noise in the cafeteria the most during lunch.

This example is very much like a science experiment, which are also typically examples of inductive reasoning. Finding a pattern in a sequence of numbers or figures and continuing the pattern is also inductive reasoning. Having students come up with their own examples of inductive reasoning- (either made up examples or examples based on their actually experiences) often helps them to really internalize the concept.

**The  $n$ th Term** - Students enjoy using inductive reasoning to find missing terms in a pattern. They are good at finding the next term, or the tenth term, but have trouble finding a generic term or rule for the number sequence. If the sequence is linear (the difference between terms is constant), they can use methods they learned in Algebra for writing the equation of a line.

Sample: Find a rule for the  $n$ th term in the following sequence: 13, 9, 5, 1,...

Sometimes making an input/output table helps students see that the term numbers are the  $x$  values and the terms are the  $y$  values.

$x$	1	2	3	4	...	$n$
$y$	13	9	5	1	...	

Since this sequence is arithmetic (each term is found by adding or subtracting the same value, or common difference, from the previous term), these points lie on a line. From the table, students can identify two points on the line such as (1, 13) and (2, 9). It may be helpful to do an example where students work in a group and each student in the group chooses a different pair of points. Then they can find the slope between the points and write the equation of the line. Each student should come up with the same equation regardless of which pair of points was chosen. In this case the equation of the line is  $y = -4x + 17$  and the rule is  $-4n + 17$ .

**True Means Always True** - In mathematics a statement is said to be true if it is always true, no exceptions. Sometimes students will think that a statement only has to hold once, or a few times to be considered true. Explain to them that just one counterexample makes a statement false, even if there are a thousand cases where the statement holds. Truth is a hard criterion to meet, proving a statement false is much less burdensome.

**Sequences** - A list of numbers is called a sequence. If the students are doing well with the number of vocabulary words in the class, the term sequence can be introduced.



## Conditional Statements

**The Advantages and Disadvantages of Non-Math Examples** - When first working with conditional statements, using examples outside of mathematics can be very helpful for the students. Statements about the students' daily lives can be easily broken down into parts and evaluated for veracity. This gives the students a chance to work with the logic, without having to use any mathematical knowledge. The problem is that there is almost always some crazy exception or grey area that students will love to point out. This is a good time to remind students of how much more precise math is compared to our daily language. Ask the students to look for the idea of what you are saying in the non-math examples, and use their powerful minds to critically evaluate the math examples that will follow. One way to help students avoid confusion is to use Euler (pronounced "Oiler") diagrams to show the relationship between the hypothesis and the conclusion. Here is an example based on the conditional statement, "If today is Saturday, then I will go to the park."



**Figure 1:** In this example, the hypothesis is, "today is Saturday." The hypothesis is written in the inner circle. The conclusion, "I will go to the park," is written in the outer circle. This diagram is interpreted like a Venn Diagram- if the statement in the inner circle is true, then the statement in the outer circle is also true.



**Figure 2:** It may help to make an "x" in the inner circle as shown in the figure and say, "You are here, where this statement is true. Does this indicate that you are also inside the circle where it is true that you will go to the park?"



**Figure 3:** This figure shows an  $x$  in the outer circle. Now students should understand that just because you are inside the circle of "going to the park", that doesn't not necessary require that you are in the circle of, "it is Saturday." It could be Saturday, but it doesn't have to be Saturday.



**Figure 4:** This final figure illustrates the scenario in which we do not go to the park. If the  $X$  is outside of the outer circle, then it is outside the “it is Saturday” circle.

**Converse and Contrapositive** - The most important variations of a conditional statement are the converse and the contrapositive. Unfortunately, these two sound similar, and students often confuse them. Emphasize the converse and contrapositive in this lesson. Ask the students to compare and contrast them. It is helpful to use the diagrams above to verify the validity of these statements. The Contrapositive can be shown to be true using the last diagram. The statement would be, “If I do not go to the park, then today is not Saturday.” The converse can be shown to be inconclusive using figure 3. The converse statement is, “If I go to the park, then today is Saturday”. Is this true? The correct answer is no, it is not necessarily true.

**Converse and Biconditional** - The converse of a true statement is not necessarily true! The important concept of implication is prevalent in Geometry and all of mathematics. It takes some time for students to completely understand the direction of the implication. Daily life examples where the converse is obviously not true is a good place to start and making the Euler diagrams should help as well. A good question for students would be, “What would the Euler diagram look like if the converse is true?” They should come to the conclusion that the two circles would completely overlap. In other words there would be one circle with two statements inside as in the example below of the conditional statement, “If an angle is a right angle, then its measure is  $90^\circ$ .”

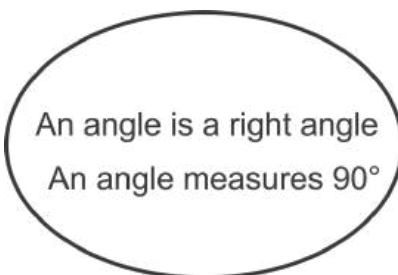

Both of these statements are equivalent because the definition of a right angle is, “an angle which measures  $90^\circ$ .” In fact, all definitions can be written as true biconditional statements. The students will spend considerable time deciding what theorems have true converses (are biconditional) in subsequent lessons.

**Practice, Practice, Practice** - Students are going to need a lot of practice working with conditional statements. It is fun to have the students write and share conditional statements that meet certain conditions. For example, have them write a statement that is true, but that has an inverse that is false. There will be some creative, funny answers that will help all the members of the class remember the material. Encourage students who are struggling to draw the Euler diagram for each conditional statement to help interpret whether or not the other statements are true.

---

## Deductive Reasoning

**Inductive or Deductive Reasoning** - Students frequently struggle with the uses of inductive and deductive reasoning. It is harder for them to see the strengths and weaknesses of each type of thinking, and understand how inductive

and deductive reasoning work together to form conclusions. Use situations that the students are familiar with where either inductive or deductive reasoning is being used to familiarize them with the different types of logic. The side by side comparison of the two types of thinking will cement the students' understanding of the concepts. It would also be beneficial to have the students write their own examples. Some examples follow.

Is inductive or deductive reasoning being used in the following paragraph? Why did you come to this conclusion?

1. The rules of Checkers state that a piece will be crowned when it reaches the last row of the opponent's side of the board. Susan jumped Tony's piece and landed in the last row, so Tony put a crown on her piece.

Answer: This is an example of detachment, a form of deductive reasoning. The conclusion follows from an agreed upon rule.

2. For the last three days a boy has walked by Ana's house at 5 pm with a cute puppy. Today Ana decides to take her little sister outside at 5 pm to show her the dog.

Answer: Ana used inductive reasoning. She is assuming that the pattern she observed will continue.

3. Paul finds the  $n^{\text{th}}$  term rule for the arithmetic sequence: 5, 9, 13, 17,... to be  $4n + 1$ . He then uses this rule to determine that the  $100^{\text{th}}$  term is 401.

Answer: This example uses both forms of reasoning. First, Paul uses inductive reasoning to determine the  $n^{\text{th}}$  term rule. He then uses deductive reasoning when he uses the rule to find the  $100^{\text{th}}$  term.

A good rule of thumb for establishing which type of reasoning is being used is to think about what part of the process is occurring. If you are coming up with a conjecture or hypothesis, then it is more likely inductive reasoning. If you are using a known rule, formula or type of argument then it is most likely deductive reasoning. As shown in the previous example, the two work together to form and then prove conjectures or "guesses" about the observed patterns.

**Valid Arguments** - Students need lots of practice recognizing the valid arguments. The Euler diagrams in the previous section can be used here as well to show that the Law of the Contrapositive and the Law of Detachment are valid. By adding a third circle, the Law of Syllogism can also be illustrated in an Euler diagram.

**Converse/Inverse Errors** - Students often make the following false conclusions in logical reasoning:

*Converse Error:* If it rains, then I will bring my umbrella. I bring my umbrella. Therefore, it is raining.

*Inverse Error:* If it rains, then I will bring my umbrella. It does not rain. Therefore, I do not bring my umbrella.

In these examples, the conclusion is made by assuming that the converse or inverse of the statement is true. We learned in the previous section that they are not necessarily true. This is a good opportunity to review these statements and revisit the Euler diagrams for them again as well.

## Algebraic and Congruence Properties

**Commutative or Associate** - Students sometimes have trouble distinguishing between the commutative and associative properties. It may help to put these properties into words. The associative property is about the order in which multiple operations are done. The commutative is about the first and second operand having different roles in the operation. In subtraction the first operand is the starting amount and the second is the amount of change. Often student will just look for parenthesis; if the statement has parenthesis they will choose associate, and they will usually be correct. Expose them to an exercise like the one below to help break them of this habit.

What property of addition is demonstrated in each of the following statements?

a.  $(x + y) + z = z + (x + y)$

b.  $(x + y) + z = x + (y + z)$

Answer: For example  $a$ , it is the commutative property that ensures these two quantities are equal. On the left-hand side of the equation the first operand is the sum of  $x$  and  $y$ , and on the right-hand side of the equation the sum of  $x$  and  $y$  is the second operand. In example  $b$ , the parentheses are grouping different variables so this is an example of the associative property.

Sometimes it helps students to come up with an expression to remember which is which. One example is: Your group of friends is the people you associate with. This indicates that the associative property refers to a change in grouping. For commutative, think of the word commute—you move from one place to another such as going from home to work. When the variables change position in the expression then it is the commutative property.

**Transitive or Substitution** - The transitive property is actually a special case of the substitution property. The transitive property has the additional requirement that the first statement ends with the same number or object with which the second statement begins. Acknowledging this to the students helps avoid confusion, and will help them see how the properties fit together. The following statement is true due to the substitution property of equality. How can the statement be changed so that the transitive property of equality would also ensure the statement's validity?

If  $ab = cd$ , and  $ab = f$ , then  $cd = f$ .

Answer: The equality  $ab = cd$  can be changed to  $cd = ab$  due to the symmetric property of equality. Then the statement would read:

If  $cd = ab$ , and  $ab = f$ , then  $cd = f$ .

This is justified by the transitive property of equality.

**Keeping It All Straight** - At this point in the class the students have been introduced to an incredible amount of material that they will need to use in proofs. Laying out a logic argument in proof form is, at first, a hard task. Searching their memories for terms at the same time makes it near impossible for many students. A notebook that serves as a "tool cabinet" full of the definitions, properties, postulates, and later theorems that they will need, will free the students' minds to concentrate on the logic of the proof. After the students have gained some experience, they will no longer need to refer to their notebook. The act of making the book itself will help the students collect and organize the material in their heads. It is their collection; every time they learn something new, they can add to it.

**All Those Symbols** - In the back of many math books there is a page that lists all of the symbols and their meanings. The use of symbols is not always consistent between texts and instructors. Students should know this in case they refer to other materials. It is a good idea for students to keep a page in their notebooks where they list symbols, and their agreed upon meanings, as they learn them in class. Some of the symbols they should know at this point in are the ones for equal, congruent, angle, triangle, perpendicular, and parallel.

**Don't Assume Congruence!** - When looking at a figure students have a hard time adjusting to the idea that even if two segments or angles look congruent they cannot be assumed to be congruent unless they are marked. A triangle is not isosceles unless at least two of the sides are marked congruent, no matter how much it looks like an isosceles triangle. Maybe one side is a millimeter longer, but the picture is too small to show the difference. Congruent means exactly the same. It is helpful to remind the students that they are learning a new, extremely precise language. In geometry congruence must be communicated with the proper marks if it is known to exist.

**Communicate with Figures** - A good way to have the students practice communicating by drawing and marking figures is with a small group activity. One person in a group of two or three draws and marks a figure, and then the other members of the group tell the artist what if anything is congruent, perpendicular, parallel, intersecting, and so on. They take turns drawing and interpreting. Have them use as much vocabulary as possible in their descriptions of the figures.

## Two-Column Proofs

**Diagram and Plan** - Students frequently want to skip over the diagramming and planning stage of writing a proof. They think it is a waste of time because it is not part of the end result. Diagramming and marking the given information enables the writer of the proof to think and plan. It is analogous to making an outline before writing an

essay. It is possible that the student will be able to muddle through without a diagram, but in the end it will probably have taken longer, and the proof will not be written as clearly or beautifully as it could have been if a diagram and some thinking time had been used. Inform students that as proofs get more complicated, mathematicians pride themselves in writing simple, clear, and elegant proofs. They want to make an argument that is undeniably true.

**Teacher Encouragement** - When talking about proofs and demonstrating the writing of proofs in class, take time to make a well-drawn, well-marked diagram. After the diagram is complete, pause, pretend like you are considering the situation, and ask students for ideas of how they would go about writing this proof.

Assign exercises where students only have to draw and mark a diagram. Use a proof that is beyond their ability at this point in the class and just make the diagram the assignment.

When grading proofs, use a rubric that assigns a certain number of points to the diagram. The diagram should be almost as important as the proof itself.

Refer students to the tips for proof writing that appear between Examples 4 and 5 of this section in the text. They should keep going back to those tips periodically until they become second nature.

**Start with “Given”, but don’t end with “Prove”** - After a student divides the statement to be proved into a given and prove statements he or she will enjoy writing the givens into the proof. It is like a free start. Sometimes they get a little carried away with this and when they get to the end of the proof write “prove” for the last reason. Remind them that the last step has to have a definition, postulate, property, or theorem to show why it follows from the previous steps. Perhaps reminding them the “prove” is a command statement, not a reason will help them remember that it is just part of the question.

**Scaffolding** - Proofs are challenging for many students. Many students have a hard time reading proofs. They are just not used to this kind of writing; it is very specialized, like a poem. One strategy for making students accustom to the form of the proof is to give them incomplete proofs and have them fill in the missing statements and reason. There should be a progression where each proof has less already written in, and before they know it, they will be writing proofs by themselves.

**Number or Geometric Object** - The difference between equality of numbers and congruence of geometric objects was addressed earlier in the class. Before starting this lesson, a short review of this distinction to remind students is worthwhile. If the difference between equality and congruence is not clear in students’ heads, the proofs in this section will seem pointless to them.

**Theorems** - The concept of a theorem and how it differs from a postulate has been briefly addressed several times in the course, but this is the first time theorems have been the focus of the section. Now would be a good time for students to start a theorem section in their notebook. As they prove, or read a proof of each theorem it can be added to the notebook to be used in other proofs.

---

## Proofs about Angle Pairs and Segments

**Mark-Up That Picture** - Angles are sometimes hard to see in a complex picture because they are not really written on the page; they are the amount of rotation between two rays that are directly written on the page. It is helpful for students to copy diagram onto their papers and mark all the angles of interest. They can use highlighters and different colored pens and pencils. Each pair of vertical angles or linear pairs can be marked in a different color. Using colors is fun, and gives the students the opportunity to really analyze the angle relationships.

**Add New Information to the Diagram** - It is common in geometry to have multiple questions about the same diagram. The questions build on each other leading the student through a difficult exercise. As new information is found it should be added to the diagram so that it is readily available to use in answering the next question.

**Try a Numerical Example** - Sometimes students have trouble understanding a theorem because they get lost in all the symbols and abstraction. When this happens, advise the students to assign a plausible number to the measures of

the angles in question and work from there to understand the relationships. Make sure the student understands that this does not prove anything. When numbers are assigned, they are looking at an example, using inductive reasoning to get a better understanding of the situation. The abstract reasoning of deductive reasoning must be used to write a proof.

**Inductive vs. Deductive Again** - The last six sections have given the students a good amount of practice drawing diagrams, using deductive reasoning, and writing proofs, skills which are closely related. Before moving on to chapter three, take some time to review the first two sections of this chapter. It is quite possible that students have forgotten all about inductive reasoning. Now that they have had practice with deductive reasoning they can compare it to inductive reasoning and gain a deeper understanding of both. They should understand that inductive reasoning often helps a mathematician decide what should be attempted to be proved, and deductive reasoning proves it.

**Review** - The second section of chapter two contains information about conditional statements that will be used in the more complex proofs in later chapters. Continue to review these variations of the conditional statement in verbal and symbolic form so that students do not forget them.

## 2.3 Parallel and Perpendicular Lines

### Lines and Angles

**Marking the Diagram** - Sometimes students confuse the marks for parallel and congruent. When introducing them to the arrows that represent parallel lines, review the ticks that represent congruent segments. Seeing the two at the same time helps avoid confusion. Also, explaining that the arrows show that the lines or segments are going in the same direction or have the same slope may help them understand why arrows are used and thus help them remember.

When given the information that two lines or segments are perpendicular, students don't always immediately see how to mark the diagram accordingly. They need to use the definition of perpendicular and mark one of the right angles created by the lines with a box.

Students also struggle with marking angle bisectors and midpoints (or segments bisectors). Just like the perpendicular lines, they aren't marking the object directly. They need to mark the *results*, which are congruent angles or congruent segments in these cases.

**Symbol Update** - Students should be keeping a list of symbols and how they will be used in this class in their notebooks. Remind them to update this page with the symbols for parallel,  $\parallel$ , and perpendicular,  $\perp$ .

**Construction** - The parallel and perpendicular line postulates are used in construction. Constructing parallel and perpendicular lines with a compass and straightedge is a good way to give students kinesthetic experience with these concepts. Construction can also be done with computer software. To construct a parallel or perpendicular line the student will select the line they want the new line to be parallel or perpendicular to, and the point they want the new line to pass through, and chose construct. The way the programs have the students select the line and then the point reinforces the postulates.

**Parallel vs Skew Lines** - Students often struggle with the difference between these two scenarios. It is difficult for them to picture the skew lines in three dimensions and even harder for them to draw them. Use concrete examples of skew and perpendicular lines (objects in the classroom) to help them visualize the difference. Also, reinforce the requirement for the lines to be coplanar in the definition of parallel lines. If it is not specifically stated that the lines are coplanar, then the lines may be skew.

**Naming the Angle Pairs Formed when a Transversal Intersects Two Lines** - Students often struggle with memorizing the names of the angle pairs. It helps to go through the names and explain how the names truly describe the angle pairs. Using colored pencils or highlighters to indicate the space in the *interior* of the parallel lines and the space in the *exterior* of the parallel lines helps distinguish between alternate exterior and alternate interior. Discussing what *alternate* vs *same side* means will help distinguish between these pair of interior angles. Corresponding angles are in the same location with respect to the transversal and the line. Using words like above or below and to the right or left helps students locate the pairs of corresponding angles, particularly in situations where the lines are not parallel and the angles don't "match".

### Properties of Parallel Lines

**The Parallel Hypothesis** - So far seven different pairs of angles that may be supplementary or congruent have been introduced. All seven of these pairs are used in the situation where two lines are being crossed by a transversal

forming eight angles. Some of these pairs require the two lines to be parallel and some do not. Students sometimes get confused about when they need parallel lines to apply a postulate or theorem, and if a specific pair is congruent or supplementary. A chart like the one below will help them sort it out.

**TABLE 2.1:**

	<b>Type of Angle Pair</b>	<b>Relationship</b>
<b>Do Not Require Parallel Lines</b>	Linear Pairs	Supplementary
	Vertical Angles	Congruent
<b>Parallel Lines Required</b>	Corresponding Angles	Congruent
	Alternate Interior Angles	Congruent
	Alternate Exterior Angles	Congruent
	Consecutive Interior Angles	Supplementary
	Consecutive Exterior Angles	Supplementary

Encourage students who are really struggling to use common sense when deciding whether a pair of angles is supplementary or congruent. When parallel lines are intersected by a transversal, any pair of two angles will be either congruent or supplementary. For students at this level, it is advisable to make these drawings accurate (i.e. make the lines look parallel if they are parallel) so that students can practice using common sense. If the angles *look congruent*, they are congruent and if one is clearly *obtuse* and the other is clearly *acute*, then they are supplementary. This goes against the idea that it is not advisable to encourage students to rely on the appearance of a diagram but for very low level students, this can really help them. In addition, practicing common sense will help them in the real world and in application problems.

**Patty Paper Activity** - When two lines are intersected by a transversal eight angles are formed in two sets of four. When the lines are parallel, the two sets of four angles are exactly the same. To help students see this relationship, have them darken a set of parallel lines on their binder paper a few inches apart (or they can use the two sides of a ruler to make the parallel lines) and draw a transversal through the parallel lines. Next, they should trace one set of four angles on some thin paper (tracing paper or patty paper). When they slide the set of four angles along the transversal they will coincide with the other set of four angles. Have them try the same thing with a set of lines that are not parallel. This will help students find missing angle measures quickly and remember when they can transfer numbers down the transversal. It does not help them learn the names of the different pairs of angles which is important for communicating with others about mathematical concepts and for writing proofs.

## Proving Lines Parallel

**When to Use the Converse** - It takes some experience before most students truly understand the difference between a statement and its converse. They will be able to write and recognize the converse of a statement, but then will have a hard time deciding which one applies in a specific situation. Tell them when you know the lines are parallel and are looking for angles, you are using the original statements; when you are trying to decide if the lines are parallel or not, you are using the converse.

**Proofs of Converse Theorems** - The textbook includes a proof of the Converse of the Alternate Interior Angles Theorem. It would be helpful to prove each of the other theorems to help students see when the converse theorems are used.

Example Proof of the Converse of the Alternate Exterior Angle Theorem:

### 2.3. PARALLEL AND PERPENDICULAR LINES



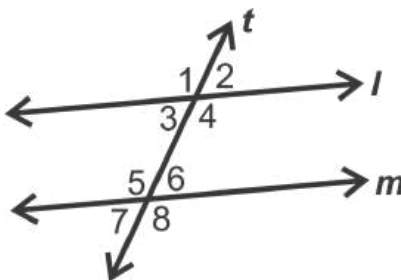

**Given:**  $\angle 1 \cong \angle 8$

**Prove:**  $l \parallel m$

**TABLE 2.2:**

Statements	Reasons
1. $\angle 1 \cong \angle 8$	1. Given
2. $\angle 1 \cong \angle 4$	2. Vertical Angles Theorem
3. $\angle 4 \cong \angle 8$	3. Transitive Property of Angle Congruence
4. $l \parallel m$	4. Converse of the Corresponding Angles Postulate

The Converse of the Alternate Interior Angle Theorem could also be proved using the Converse of the Alternate Exterior Angle Theorem. This would demonstrate to the students that once a theorem has been proved, it can be used in the proof of other theorems. This demonstrates the building block nature of math. Here is one way to do this using the same diagram from above.

**Given:**  $\angle 1 \cong \angle 8$

**Prove:**  $l \parallel m$

**TABLE 2.3:**

Statements	Reasons
1. $\angle 1 \cong \angle 8$	1. Given
2. $\angle 1 \cong \angle 4$	2. Vertical Angles Theorem
3. $\angle 5 \cong \angle 8$	3. Vertical Angles Theorem
4. $\angle 4 \cong \angle 5$	4. Substitution Property of Angle Congruence
5. $l \parallel m$	5. Converse of the Alternate Interior Angles Theorem

Proving the theorem in several ways gives students a chance to practice with the concepts and their proof writing skills. Similar proofs can be assigned for the other theorems in this section.

## Properties of Perpendicular Lines

**Complementary, Supplementary, or Congruent** - When finding angle measures, students generally need to decide between three possible relationships: complementary, supplementary, and congruent. A good way for them to practice with these and review their equation solving skills, is to assign variable expressions to angle measures, state the relationship of the angles, and have the students use this information to write an equation that when solved will lead to a numerical measurement for the angle. Encourage students to take the time to write out and solve the equation neatly. This process helps them avoid errors. Many times students will find the value of  $x$ , and then stop without plugging in the value to the expression for the angle measures. Have the students find the actual angles

measures by plugging their  $x$  value in to verify that their final answers are angle measures that have the desired relationship.

**Interpreting “Word” Questions** – Students often have difficulty translating the words in a statement into an algebraic equation. Here are a couple examples that might help students interpret verbal questions that are not accompanied by a diagram.

Example 1: Two vertical angles have measures  $(2x - 30)^\circ$  and  $(x + 60)^\circ$ . Find the measures of the two angles.

Students may wish to make a diagram of vertical angles, then label them with these measures before setting up the equation:  $2x - 30 = x + 60$ . Once they solve for  $x$ , students need to plug this value into both expressions to get the measures of the two angles.

Remind students that these angles should have equal measures. Model for students the process of checking your answers for reasonableness by asking them if the values make sense and how they know. At first they may have trouble answering these questions but if you consistently model this process, it may become second nature to them as well and help them to identify and correct mistakes as they solve problems throughout the course.

Example 2: The outer rays of two adjacent angle with measures  $(4x + 10)^\circ$  and  $(5x - 10)^\circ$  are perpendicular. Find the measures of each angle.

This example contains a lot of information that students will need to sort out. In this case a diagram is especially useful. Break down the information with students and help them diagram the angles to discover that the sum of the two angles must be  $90^\circ$ . Here is the equation and value of  $x$ :

$$\begin{aligned}4x + 10 + 5x - 10 &= 90 \\x &= 10\end{aligned}$$

Using this value of  $x$ , the two angles are  $50^\circ$  and  $40^\circ$ , respectively. Do these measures make sense? How do you know? Practice asking and answering these questions yourself so you can help students answer them correctly.

Example 3: The angles of a linear pair have measures  $(3x + 45)^\circ$  and  $(2x + 35)^\circ$ . Find the measure of each angle.

Example 4: Perpendicular lines form an angle with measure  $(8x + 10)^\circ$ . What is the value of  $x$ ?

Again, help students interpret the given information to make a diagram and set up an equation to solve. Then remind students to plug in their  $x$  value to find the actual angle measures. Finally, prompt students to check their work for reasonableness and accuracy.

Answers:

Example 3:  $x = 20^\circ$  and the angles are  $105^\circ$  and  $75^\circ$ .

Example 4:  $x = 10^\circ$

**Proof Tip** - In a proof, students must first state which lines are perpendicular and why, then they can say that all four angles formed by those perpendicular lines are right angles, then right angles are congruent, etc. Students are apt to just jump to the final conclusion because the lines are perpendicular. In a complete proof, these middle steps are important to show understanding of the thought process. Refer to the proof in question 26 of the review problems for an example.

## Parallel and Perpendicular Lines in the Coordinate Plane

**Order of Subtraction** - When calculating the slope of a line using two points it is important to keep straight which point was made point one and which one was point two. It does not matter how these labels are assigned, but the order of subtraction has to stay the same in the numerator and the denominator of the slope ratio. If students switch

### 2.3. PARALLEL AND PERPENDICULAR LINES

the order they will get the opposite of the correct answer. If they have a graph of the line, ask them to compare the sign of the slope to the direction of the line. Is the line increasing or decreasing? Does that match the slope? This will give them another opportunity to practice checking their results for reasonableness.

Another strategy to help students with this is to have them write the points vertically and subtract as shown in the diagram below:

$$\begin{array}{r} (4, -3) \\ \downarrow \\ (-2, 5) \\ \downarrow \end{array}$$

$$\frac{-3-5}{4-(-2)} = \frac{-8}{6} = \frac{-4}{3}$$

**Graphing Lines with Integer Slopes** - The slope of a line is the ratio of two numbers. When students are asked to graph a line with an integer slope they often fail to realize what and where the second number is. Frequently they will make the “run” of the line zero and graph a vertical line. It is helpful to have them write the slope as a ratio over one before they do any graphing. They may only need to do this a few times on paper before they are able to graph the lines correctly.

**Zero or Undefined** - Students need to make these associations:

Zero in numerator – slope is zero – line is horizontal

Zero in denominator – slope is undefined – line is vertical

Students frequently switch these around. Try to connect these concepts to their experiences. For example explain that when they are walking on a flat surface, they are not going up or down so the slope is zero. Ask them if they can walk up a vertical wall, hopefully they will say, “No.” Then you can explain that the slope of this wall is undefined. After the relationships are explained in class, remind them frequently, maybe have a poster up in the room that shows lines with a positive slope, negative slope, zero slope (horizontal) and undefined slope (vertical). You could also write the relationship on a corner of the board that does not get erased.

Students also struggle with realizing that a line perpendicular to a horizontal line is vertical and vice versa. When they look at these equations, the slope is not evident and so they don’t know what to do. Practice lots of examples with horizontal and vertical lines.

**Use Graph Paper** - Making a connection between the numbers that describe a line and the line itself is an important skill. Requiring that the students use graph paper encourages them to make nice, thoughtful graphs, and helps them make this connection.

**The y-axis is Vertical** - When using the slope-intercept form to graph a line or write an equation, it is common for students to use the x-intercept instead of the y-intercept. Remind them that they want to use the vertical axis, y-intercept, to begin the graph. Requiring that the y-intercept be written as a point, say (0, 3) instead of just 3, helps to alleviate this problem.

**Where’s the Slope** - Students are quickly able to identify the slope as the coefficient of the x-variable when a line is in slope-intercept form. Unfortunately they sometimes extend this to standard form. Remind the students that if the equation of a line is in standard form, or any other form, they must first algebraically convert it to slope-intercept form before they can easily read off the slope. It is wise to do several examples which require changing the equation from standard form into slope-intercept form.

**Why Use Standard Form** - The slope-intercept form of the line holds so much valuable information about the graph of a line that students probably won’t understand why any other form would ever be used. Mention to them that standard form is convenient when solving systems and putting equations into matrices, things they will be doing in their second year of algebra, to motivate them to learn and remember the standard form.

**Organizing Work in Multi-Step Problems** - Part of the struggle with these problems is that students get lost in the process. They get wrapped up in a particular step and forget where they are going. It may be helpful to have students write out the steps they will need to follow in the beginning so that they will have a road map to follow. They can

even leave some space between each step to go back and fill in with their work. Here is an example of this:

Find the equation of the line that is perpendicular to the line passing through the points (5, 7) and (12, 3) and passes through the second point.

1) Find the slope between the given two points.

$$m = \frac{3 - 7}{12 - 5} = \frac{-4}{7}$$

2) Find the opposite reciprocal (perpendicular) slope.

$$\perp m = \frac{7}{4}$$

3) Use the perpendicular slope and the given point (12, 3) to find the y-intercept.

$$\begin{aligned} 3 &= \frac{7}{4}(12) + b \\ 3 &= 21 + b \\ -18 &= b \end{aligned}$$

4) Write the new equation.

$$y = \frac{7}{4}x - 18$$

Many students forget that at the end they need to write an equation with variables  $x$  and  $y$ . They don't quite understand that this is an equation that relates all possible pairs of  $x$  and  $y$  coordinates. Explain to them that they need to use the given pair to determine what the  $y$ -intercept is, but not in the final equation.

## The Distance Formula

**The Perpendicular Distance** - In theory, measuring along a perpendicular line makes sense to the students, but in practice, when lining up the ruler or deciding which points to put in the distance formula, there are many distractions. Students can evaluate their decision by taking a second look to see if the path they chose was the shortest one possible. This is another opportunity to practice checking their work for reasonableness.

**Where to Measure?** - Now that the students know to measure along a line that is perpendicular to both parallel lines, they might wonder where along the lines to measure. When working on a coordinate plane it is best to start with a point that has integer coordinates, just to keep the problem simple and accurate. They will get the same distance no matter where they measure though. You may wish to share the alternate definition of parallel lines: Two lines that are a constant distance apart.

**Order of Operations** - Students might want to cancel the squares with the square root in the distance formula, even though they cannot. See example below:

$$\sqrt{(x_1 - x_2)^2 + (y_1 - y_2)^2} \neq (x_1 - x_2) + (y_1 - y_2)$$

Remind students that the square root is like parenthesis. The operations contained inside the square root must be performed before the square root can be taken. Give students lots of opportunity to practice finding the distance between two points to practice this formula.

## 2.4 Triangles and Congruence

### Triangle Sums

**Interior vs. Exterior Angles** - Students frequently have trouble keeping interior and exterior angles straight. They may fail to identify to which category a specific angle belongs and include an exterior angle in a sum with two interior. They also sometimes use the wrong total,  $360^\circ$ , versus  $180^\circ$ . Encourage the students to draw the figure on their papers and color code it. They can highlight or use a specific color of pencil to label all the exterior angle measures and another color for the interior angle measures. Then it is easy to do some checks on their work. Each interior/exterior adjacent (linear) pair should have a sum of  $180^\circ$ , all of the interior angles should add to  $180^\circ$ , and the measures of the exterior angles total  $360^\circ$ .

**Find All the Angles You Can** - When a student is asked to find a specific angle in a complex figure and they do not immediately see how they can do it, they can become stuck, and not see how to proceed. A good strategy is to find any angle they can and write the measures in the diagram, even if it is not the one they are after. Finding other angles keeps their brains active and working, they practice using angle relationships, and the new information will often help they find the target angle. Students often miss possible connections when they don't write down all of the angles as they find them. It is important that students know that many exercises are not designed to do in one step.

**Congruent Angles in a Triangle** - In later sections students will study different ways of determining if two or more angles in a triangle are congruent, and will then have to use this information to find missing angles in a triangle. To start them on this process it is good to have them work with triangles in which two angles are stated to be congruent. A few example problems follow:

Example 1: An acute triangle has two congruent angles each measuring  $70^\circ$ . What is the measure of the third angle?

Encourage students to make a triangle diagram and label two angles  $70^\circ$ . This helps review making and marking diagrams and gives them a concrete visual to work with. Next, students should set up an equation showing that the two given angles plus the third, unknown angle, will add up to  $180^\circ$ . Finally, students should solve and find that the third angle is  $40^\circ$ .

Example 2: An obtuse triangle has two congruent angles. One angle of the triangle measures  $130^\circ$ . What are the measures of the other two angles?

Again, drawing a diagram will help students organize their thoughts. They will recognize that the obtuse angle cannot be one of the congruent angles. They should arrive at the conclusion that each of the congruent angles should be  $25^\circ$ .

### Congruent Figures

**Rotation Difficulties** - When congruent triangles are shown with different orientations, many students find it difficult to rotate the figures in their head to align corresponding sides and angles. Remind them that the angles and sides marked congruent are the corresponding pairs of angles and sides. Have students practice listing the corresponding pairs of congruent sides and angles. Another recommendation is to redraw the figures on paper so that they have the same orientation. It may be necessary for students to physically rotate the paper at first. After students have had some time to practice this skill, most will be able to skip this step.

**Stress the Definition** - The definition of congruent triangles requires six congruencies, three pairs of angles and three pairs of sides. If students understand what a large requirement this is, they will be more motivated to develop the congruence shortcuts in subsequent lessons.

**The Language of Math** - Many students fail to see that math is a language, a form of communication, which is extremely dense. Just a few symbols hold great amounts of information. The congruence statements for example, not only tell the reader which triangles are congruent, but which parts of the triangle correspond. When put in terms of communication students have an easier time understanding why they must put the corresponding vertices in the same order when writing the congruence statement.

**Third Angle Theorem by Proof** - In the text an example is given to demonstrate the Third Angle Theorem, this is inductive reasoning. A deeper understanding of the theorem, and different types of reasoning, can be gained by using deductive reasoning to write a proof. It will also reinforce the idea that theorems must be proved, and shows how inductive and deductive reasoning work together. Use review question 23 as a template for a proof of the Third Angle Theorem.

## Triangle Congruence Using SSS and SAS

**One Triangle or Two** - In previous chapters, students learned to classify a single triangle by its sides. Now students are comparing two triangles by looking for corresponding pairs of congruent sides. Evaluating the same triangle in both of these ways helps the students remember the difference, and is a good way to review previous material. For instance, students could be asked to draw a pair of isosceles triangles that are not congruent, and a pair of scalene triangles that can be shown to be congruent with the SSS postulate.

**Congruent Segments** - This is a good time to remind students that overlapping (shared) segments will be congruent. Also, remind students that when they are given a midpoint, they can mark the two halves of the segment congruent. Practice this with them and illustrate marking the diagram appropriately.

**Correct Congruence Statements** - Determining which vertices of congruent triangles correspond is more difficult when no congruent angles are marked. Once the students have determined that the triangles are in fact congruent using the SSS Congruence postulate, it is advisable for them to mark congruent angles before writing the congruence statement. Corresponding congruent angles are found by matching up side markings. The angle made by the sides marked with one and two tick marks corresponds to the angle made by the corresponding sides in the other triangle, and so on.

**The Included Angle** - Students often have a hard time differentiating between SAS and SSA. It helps to have students practice identifying the angle included between two particular sides in a triangle. This should be practiced using a diagram and using the name of the triangle. This will help students identify which triangle congruence theorem is being used are help them identify correct pairs of corresponding triangle parts.

Example: What is the included angle between sides  $\overline{AB}$  and  $\overline{BC}$  in  $\triangle ABC$ ?

Answer: The included angle is  $\angle B$ . Note that it is the point that is an endpoint in both segments.

**Tricky Problems** - When looking to see which triangle congruence theorem is being used, students are liable to only look at one of the triangles and make a mistake as shown in the example below. This is problem #3 from the review questions for this section in the textbook.

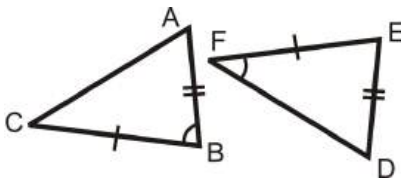

If a student were to only look at  $\triangle ABC$ , he or she might say that these triangles are congruent by SAS. The second triangle, though it does have a pair of sides and an angle congruent to a pair of sides and an angle in the first triangle, does not have the angle *included* between the sides.

**SSA** - Students are apt to try to use this as a triangle congruence theorem. It is helpful to have them attempt to construct two different triangles with the same two side lengths and non-included angle. This will only be possible in certain cases (think back to the ambiguous case for the Law of Sines- this is the connection). Here are two side lengths and a non-included angle for which two distinct triangles can be formed.  $\triangle ABC$  with  $\overline{AB} = 12\text{ cm}$ ,  $\overline{BC} = 5\text{ cm}$  and  $m\angle A = 35^\circ$ .

Student diagrams should look something like this:

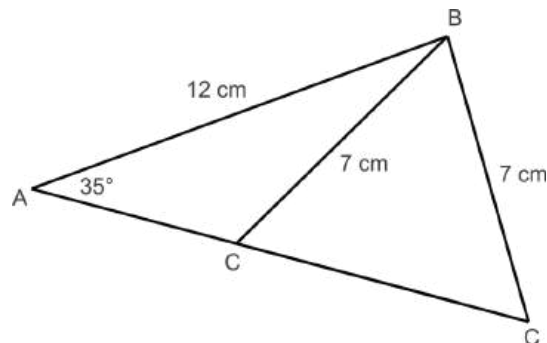

This diagram is scaled down but should reflect the general “shape” of student work.

**Using the Distance Formula to Prove Triangles Congruent** - It may be necessary to review the distance formula with students again and remind them that they cannot “distribute” the square root. In other words, remind them that:

$$\sqrt{(x_1 - x_2)^2 + (y_1 - y_2)^2} \neq (x_1 - x_2) + (y_1 - y_2)$$

## Triangle Congruence Using ASA, AAS and HL

**AAA** - Students sometimes have to think for a bit to realize that AAA does not prove triangle congruence. Ask them to think back to the definition of triangle. Congruent triangles have the same size and shape. Most students intuitively see that AAA guarantees that the triangles will have the same shape. To see that triangles can have AAA and be different sizes ask them to consider a triangle they are familiar with, the equiangular triangle. They can draw an equiangular triangle on their paper, and you can draw an equiangular triangle on the board. The triangles have AAA, but are definitely different in size. This is a counterexample to AAA congruence. Have the students note that the triangles are the same shape; this relationship is called similar and will be studied in later chapters.

**Why Not LL?** - Some students may wonder why there is not a LL shortcut for the congruence of right triangles. It also leads to SSS when the Pythagorean theorem is applied. Have the students explore the situation with a drawing. They can draw out two congruent right triangles and mark sides so that the triangles have LL. There is already a congruence guarantee for this, SAS. What would the non-right triangle congruence be for HL? Is this a guarantee? (It would be SSA, and no, this does not work in triangles that are not right.)

**Importance of Right Triangles** - When using math to model situations that occur in the world around us the right triangle is used frequently. Have the students think of right angles that they see every day: walls with the ceilings and the floors, windows, desks, and many more constructed objects. Right triangles are also important in trigonometry which they will be studying soon. Stressing the usefulness of right triangles will motivate them to think about why HL guarantees triangle congruence but SSA, in general, does not.



**Congruent Angle/Segment Pairs** - It is important to review what pairs of angles will be congruent in diagrams. Students may forget that they can mark vertical angles and shared (overlapping) angles congruent. They may also need a reminder that if segments are parallel, then alternate interior angles will be congruent. Remind them as well that shared sides can be marked congruent.

**Marking the Diagram** - Once again, students should be encouraged to mark all given information and all deduced congruencies in their diagrams. Seeing the markings will help them determine which triangle congruence theorem is being utilized.

**An Important Distinction** - At first students may not see why it is important to identify whether ASA or AAS is the correct tool to use for a specific set of triangles. They both lead to congruent triangles, right? Sometimes either can be used to prove triangles are congruent, but this will not always be the case, as they will see in the next lesson. Sometimes the configuration of the corresponding congruent sides and angles in the triangles determines if the triangles can be proved to be congruent or not. Knowing this will motivate students to study the difference between ASA and AAS. This is a good time to practice identifying the “included” side between two angles. This will help students see when a side is included and when it is not.

**AAS or SAA** - Sometimes students try to list the congruent sides and angles in a circle as they move around the triangle. This could result in AAS or SAA when there are two pairs of congruent angles and one pair of congruent sides that is not between the angles. They know AAS proves congruence and want to know if SAA does as well. When this occurs it is best to redirect their thinking process. With two sets of angles and one set of sides there are only two possibilities, the side is between the angles or it is another side. When it is between the angles we have ASA, if it is either of the other two sides we use SAA. This same situation occurs with SSA, but is even more important since SSA is not a test for congruence. A good way for the students to remember this is that when the order of SSA is reversed it makes an inappropriate word. This word should not be used in class or in proofs, even if it is spelled backwards.

**Patterns and Structure** - All of the shortcuts to triangle congruence require three pieces of information. Reinforce this concept with students as you complete proofs. Students often wonder why we need to include statements such as  $\overline{BC} \cong \overline{BC}$  when it is so obvious to them that it is the same segment and that it has to be congruent to itself. It is important to the structure of the proof that we include exactly which segment and/or angle pairs we are using in order to conclude the triangles are congruent by a particular triangle congruence theorem.

---

## Isosceles and Equilateral Triangles

**The Useful Definition of Congruent Triangles** - The arguments used in the proof of the Base Angle Theorem apply what the students have learned about triangles and congruent figures in this chapter, and what they learned about reasoning and implication in the second chapter. It is a lot of information to bring together and students may need to review before they can fully understand the proof.

This is a good point to summarize what the students have learned in this chapter about congruent triangles and demonstrate how it can be put to use. To understand this proof, students need to remember that the definition of congruent triangles requires three pairs of congruent sides and three pairs of congruent angles, but realize that not all six pieces of information need to be verified before it is certain that the triangles are congruent. There are shortcuts. The proof of the Base Angle Theorem uses one of these shortcuts and jumps to congruence which implies that the base angles, a pair of corresponding angles of congruent triangles, are congruent.

To a student new to geometry this argument is not as straightforward as it may seem to an instructor experienced in mathematical proofs. Plan to take some time explaining this important proof.

**A Proved Theorem Can Be Used** - Now that the students have the proof of the Base Angle Theorem they can use it as opportunities present themselves. They should be on the lookout for isosceles triangles in the proofs of other theorems, in complex figures, and in all other situations. When they spot them, they need to immediately apply the

Base Angle Theorem and mark those base angles congruent. This is true for the converse as well. When they spot a triangle with congruent angles, they should mark the appropriate sides congruent. Students sometimes do not realize what a powerful tool this theorem is and that they will be using it extensively throughout this class, and in math classes they will take in the future.

**The Process of Writing a Proof** - When students first start examining pairs of triangles to determine congruence it is difficult for them to sort out all the sides and angles.

The first step is for them to copy the figure onto their paper. It is helpful to color code the sides and angles, congruent sides marked in one color and the congruent angles in another. Some congruent parts will not be marked in the original figure that is given to the students in the text. For example, there could be an overlapping side that is congruent to itself, due to the reflexive property; mark it as well. Then they should do a final check to ensure that the congruent parts do correspond.

The next step is for them to count how many pairs of congruent corresponding sides and how many pairs of congruent corresponding angles there are. With this information they can eliminate some possibilities from the list of way to prove triangles congruent. If there is no right angle they can eliminate HL, or if they only have one set of corresponding congruent angles, they can eliminate both ASA and AAS.

If at this point there is still more than one possibility, they are going to need to decide if an angle is between two sides or if a side is between two angles. Remind them that both ASA and AAS can be used to guarantee triangle congruence, and that SAS works, but that SSA cannot be used to prove two triangles are congruent.

If all postulates and theorems have been eliminated, then it is not possible to determine if the triangles are congruent.

## 2.5 Relationships with Triangles

### Midsegments

**Don't Forget the  $\frac{1}{2}$**  – In this section there are two types of relationships that the students need to keep in mind when writing equations with variable expressions. The first involves the midpoint. When the expressions represent the two parts of a segment separated by the midpoint they just have to set the expressions equal to each other. The second is when comparing the length of a side of the triangle with the midsegment parallel to it. In this case they need to multiply the expression representing the side of the triangle by  $\frac{1}{2}$ , and then set it equal to the expression representing the midsegment. They may forget the  $\frac{1}{2}$  or forget to use parenthesis and distribute. Remind them that they need to multiply the entire expression by  $\frac{1}{2}$ , not just the first term. Similarly, they may mess up the distribution going the other way. When given the midsegment, they must multiply the whole expression by 2 to get the third side of the triangle.

**Midpoint Formula, Distance Formula and Slope Formula** - You may need to review these formulas again. Remind students that the Midpoint Formula produces a point. Also, remind students that the slopes of parallel lines are the same.

**Parallel** - Students may forget that a midsegment is also parallel to the third side of a triangle. They are apt to focus most on the length relationship since it is used most in the problem sets.

### Perpendicular Bisectors and Angle Bisectors in Triangles

**Construction Frustrations** - Using a compass and straightedge to make clean, accurate constructions takes a bit of practice. Some students will pick up the skill quickly and others will struggle. Practice, practice, practice. Help the students individually to make nice arcs. A few minutes of practicing just making circles will help them to get more comfortable and accurate with the compass. They will know right away if they are changing the size of the arc mid circle because the “ends” will not meet up. What is nice about doing construction in the classroom is that it is often the students that typically struggle with mathematics, the more artistically minded students, that excel and learn from constructing figures.

Here are some other tips for good construction: (1) Hold the compass at an angle to the paper rather than perpendicularly. Suggest that students try not to press down very hard- a light arc is sufficient and will be easier to make. (2) Try rotating the paper while holding the compass steady. (3) Work on a stack of a few papers so that the needle of the compass can really dig into the paper and will not slip. (4) Suggest that students hold the compass by the “circle” or vertex where the two radii meet- often students will try to hold the compass by the needle and pencil and they grip it so tightly that they change the angle in mid arc.

**Perpendicular Bisector Quirks** - There are two key ways in which the perpendicular bisector of a triangle is different from the other segments in the triangle that the students will learn about in subsequent sections. Since they are learning about the perpendicular bisector first these differences do not become apparent until the end of the chapter.

The perpendicular bisector of the side of a triangle does not have to pass through a vertex. Have the students explore in what situations the perpendicular bisector does pass through the vertex. They should discover that this is true for

equilateral triangles and for the vertex angle of isosceles triangles.

The point of concurrency of the three perpendiculars of a triangle, the circumcenter, can be located outside the triangle. This is true for obtuse triangles. The circumcenter will be on the hypotenuse of a right triangle. This is also true for the orthocenter, the point of concurrency of the altitudes.

**Circumcenter and Perpendicular Bisector Relationship** - Stress the relationship between the points on a perpendicular bisector and the center of a circle. Remind students that the definition of the center of a circle is the point equidistant from every point on the circle. Remind students that every point on a perpendicular bisector is equidistant from the endpoints of a segment. Make the connection that this means that the point of concurrency of the perpendicular bisectors is equidistant from all three vertices of the triangle. This means that the vertices all lay on a circle with the center at this point of concurrency- the circumcenter.

**Same Construction for Midpoint and Perpendicular Bisector** - The Perpendicular Bisector Theorem is used to construct the perpendicular bisector of a segment and to find the midpoint of a segment. When finding the midpoint, the students should make the arcs, one from each endpoint with the same compass setting, to find two equidistant points, but instead of drawing in the perpendicular bisector, they can just line up their ruler and mark the midpoint. This will keep the drawing from getting overcrowded and confusing.

**Incenter and Angle Bisector Relationship** - Stress the relationship between the incenter and the angle bisectors of a triangle. Again, discuss the definition of the center of a circle. Also, remind students that all the points on an angle bisector are equidistant from the sides of the angles. In this case, the point of concurrency of the angle bisectors will be equidistant from the three sides of the triangle. Remind students that the distance measured from a point to a line (or segment in this case) is measured along a perpendicular segment. You may wish to demonstrate constructing the perpendiculars from the incenter to each of the sides. This segment is the radius of the inscribed circle. Students may not be able to do this accurately themselves but doing this in a demonstration for them may help make the concept stick.

**Adaptation** - For practical purposes, you may wish to skip having students construct the perpendiculars to determine the correct compass setting for the inscribed circle. In this case, have students to place the center of the compass at the incenter, choose one side, and adjust the compass setting until the compass brushes by that side of the triangle, without passing through it. The word tangent does not have to be introduced at this point if the students already have enough vocabulary to learn. When the incenter is correctly placed, the compass should also hit the other two sides of the triangle once, creating the inscribed circle.

**Check with a Third** - When constructing the point of concurrency of the perpendicular bisectors or angle bisectors of a triangle, it is strictly necessary to construct only two of the three segments. The theorems proved in the texts ensure that all three segments meet in one point. It is advisable to construct the third segment as a check of accuracy. Sometimes the compass will slip a bit while the student is doing the construction. If the three segments form a little triangle, instead of meeting at a single point, the student will know that their drawing is not accurate and can go back and check their marks.

**Special Triangles** - In some special triangles, these segments overlap. The following examples may be used to have students explore these cases.

Example 1: Construct an equilateral triangle. Now construct the perpendicular bisector of one of the sides. Construct the angle bisector from the angle opposite of the side with the perpendicular bisector. What do you notice about these two segments? Will this be true of a scalene triangle? Consider what would happen if you found the circumcenter and the incenter. Where would they be located?

Answer: The segments should coincide on the equilateral triangle, but not on the scalene triangle. The incenter and the circumcenter will be located in the same place. You could extend this to an isosceles triangle to show that the angle bisector of the vertex angle overlaps with the perpendicular bisector of the base.

Example 2: Construct an equilateral triangle. Now construct one of the angle bisectors. This will create two right triangles. Label the measures of the angles of the right triangles. With your compass compare the lengths of the shorter leg to the hypotenuse of either right triangle. What do you notice?

## 2.5. RELATIONSHIPS WITH TRIANGLES

Answer: The hypotenuse should be twice the length of the shorter leg. You may wish to refer back to this example in the next lesson to show that the angle bisector is the same segment as the median in an equilateral triangle.

---

## Medians and Altitudes in Triangles

**Vocabulary Overload** - So far this chapter has introduced to a large number of vocabulary words, and there will be more to come. This is a good time to stop and review the new words before the students become overwhelmed. Have them make flashcards, or play a vocabulary game in class.

**Label the Picture** - When using the Concurrency of Medians Theorem to find the measure of segments, it is helpful for the students to copy the figure onto their paper and write the given measures by the appropriate segments. When they see the number in place, it allows them to concentrate on the relationships between the lengths since they no longer have to work on remembering the specific numbers.

**Median or Perpendicular Bisector** - Students sometimes confuse the median and the perpendicular bisector since they both involve the midpoint of a side of the triangle. The difference is that the perpendicular bisector must be perpendicular to the side of the triangle, and the median must end at the opposite vertex. Show lots of examples of the two of these on the same triangle so students have a visual memory of the difference. Discuss with students (or have them explore and then discuss) that these segments will be the same for each vertex and opposite side in equilateral triangles and for the median drawn from the vertex angle of an isosceles triangle and the perpendicular bisector of the base.

**Applications** - Students are much more willing to spend time and effort learning about topics when they know of their applications. Questions like the ones below improve student motivation.

In the following situations would it be best to find the circumcenter, incenter, or centroid?

Example 1: The drama club is building a triangular stage. They have supports on all three corners and want to put one in the middle of the triangle.

Answer: Centroid, because it is the center of mass or the balancing point of the triangle

Example 2: A designer wants to fit the largest circular sink possible into a triangular countertop.

Answer: Incenter, because it is equidistant from the sides of the triangle.

**Extending the Side** - Many students have trouble knowing when and how to extend the sides of a triangle when drawing in an altitude. First, this only needs to be done with obtuse triangles when drawing the altitude that intersects the vertex of one of the acute angles. It is the sides of the triangle that form the obtuse angle that need to be extended. The students should rotate their paper so that the vertex of the acute angle they want to start an altitude from is above the other two, and the segment opposite of this vertex is horizontal. Now they just need to extend the horizontal side until it passes underneath the raised vertex.

**The Altitude and Distance** - The distance between a point and a line is defined to be the shortest segment with one endpoint on the point and the other on the line. It has been shown that the shortest segment is the one that is perpendicular to the line. So, the altitude is the segment along which the distance between a vertex and the opposite side is measured. Seeing this connection will help students remember and understand why the length of the altitude is the height of a triangle when calculating the triangle's area using the formula  $A = \frac{1}{2} bh$ .

**Orthocenter** - Students need to connect this term to something to help them remember that it is the point of concurrency of the altitudes in a triangle. They are likely unfamiliar with the term orthogonal - which means perpendicular. Telling them this may help them connect the term orthocenter to the altitudes (or perpendicular segments from vertices to the opposite side in triangles).

**Explorations** - When students discover a property or relationship themselves it will be much more meaningful. They will have an easier time remembering the fact because they remember the process that resulted in it. They will

also have a better understanding of why it is true now that they have experience with the situation. Unfortunately, students sometimes become frustrated with explorations. They may not understand the instruction, or they may not be carefully enough and the results are unclear. Some of the difficulties can be alleviated by having the students work in groups. They can work together to understand the directions and interpret the results. Students strong in one area, like construction, can take on that part of the task and help the others with their technique.

Some guidelines for successful group work.

- Groups of three work best.
- The instructor should choose the groups before class.
- Students should work with new groups as often as possible.
- Desks or tables should be arranged so that the members of the group are physically facing each other.
- The first task of the group is to assign jobs: person one reads the directions, person two performs the construction, person three records the results. Students should regularly trade tasks.
- Teachers need to circulate and provide additional assistance so that groups do not get frustrated or go off task.

---

## Inequalities in Triangles

**The Opposite Side/Angle** - At first it may be difficult for students to recognize what side is opposite a given angle or what angle is opposite a given side. If it is not obvious to them from the picture, obtuse, scalene triangles can be confusing, they should use the names. For  $\triangle ABC$ , the letters are divided up by the opposite relationship, the angle with vertex  $A$  is opposite the side with endpoints  $B$  and  $C$ . Being able to determine these relationships without a figure is important when studying trigonometry.

**Small, Medium, and Large** - When working with the relationship between the sides and angles of a triangle, students will summarize the theorem to “largest side is opposite largest angle”. They sometimes forget that this comparison only works within one triangle. There can be a small obtuse triangle in the same figure as a large acute triangle. Just because the obtuse angle is the largest in the figure, does not mean the side opposite of it is the longest among all the segments in the figure, just that it is the longest in that obtuse triangle. If the triangles are connected or information is given about the sides of both triangles, a comparison between triangles could be made. See exercise #29 in the text.

**Add the Two Smallest** - The triangle inequality says that the sum of the lengths of any two sides of a triangle is greater than the length of the third side. In practice it is enough to check that the sum of the lengths of the smaller two sides is larger than the length of the longest side. When given the three sides lengths for a triangle, students who do not fully understand the theorem will add the first two numbers instead of the smallest two. When writing exercises it is easy to always put the numbers in ascending order without thinking much about it. Have the students try to draw a picture of the triangle. After making a few sketches they will understand what they are doing, instead of just blindly following a pattern.

**Range of Possible Lengths** - Students are so used to finding a single “answer” to a problem that they often struggle with the idea that the third side of a triangle could take on multiple possible lengths and how to figure out this range of values. A shortcut is that the length of the third side is always between the difference and sum of the two known lengths. Students also do not immediately understand why the inequality shows values that the third side cannot assume. For example in a triangle with known sides, 5 and 8, the range of possible values for the third side is  $3 < x < 13$ . They may question why it isn't  $4 < x < 12$  since the third side cannot be 3 or 13. Remind them that the sides don't have to have whole number lengths.

**SSS and SAS Use Color** - When the figures have two triangles instead of just one, they become more complex. The students may need some help sorting out the shapes. A good way for them to begin this process is to draw the figure on their paper and use highlighters to color code the information.

Both of the theorems presented in this section require two pairs of congruent sides. The first step is for student to

### 2.5. RELATIONSHIPS WITH TRIANGLES

highlight these four sides in a common color, let's say yellow. Once they have identified the two pairs of congruent sides, they know the hypothesis of the theorem has been filled and they can apply the conclusion.

The conclusions of these theorems involve the third side and the angle between the two congruent sides. These parts of the triangles can be highlighted in a different color, let's say pink.

Now the students need to determine if they need to use the SAS Inequality theorem or the SSS inequality theorem. If they know one of the pink angles is bigger than the other, then they will use the SAS Inequality theorem and write an inequality involving the pink sides. If they know that one of the pink sides is bigger than the other, they will apply the SSS Inequality theorem, and write an inequality involving the two pink angles.

Having a step-by-step process is good scaffolding for students as they begin working with new types of problems. After the students have gained some experience, they will no longer need to go through all the steps.

**Solving Inequalities** - Students learned to solve inequalities in algebra, but a short review may be in order. Solving inequalities involves the same process as solving equations except the equal sign is replaced with an inequality, and there is the added rule that if both sides of the inequality are multiplied or divided by a negative number the direction of the inequality changes. Students frequently want to change the direction of the inequality when it is not required. They might mistakenly change the inequality if they subtract from both sides, or if result of multiplication or division is a negative even if the number used to change the inequality was not negative. In geometry it is most common to be working with all positive numbers, but depending on how the students apply the Properties of Inequalities, they may create some negative values.

---

## Extension: Indirect Proof

**Why Learn Indirect Proof** - For a statement to be mathematically true it must always be true, no exceptions. This frequently makes it easier to prove that a statement is false than to prove it is true. Indirect proof gives mathematician the choice between proving a statement true or proving a statement false and can therefore greatly simplify some proofs. Letting the students know that indirect proof can be a potential shortcut will motivate them to learn to use this type of logic.

**Indirect Proof** - Students will not really understand the method of indirect proof the first time they see it. Let them know that this is just the first introduction, and that in subsequent lessons they will be given more examples and opportunities to learn this new method of proof. If students think they are supposed to understand something perfectly the first time they see it, and they don't, they will become frustrated with themselves and mathematics. Let them know that the brain needs time and multiple exposures to master these challenging concepts.

**Review the Contrapositive** - Proving a statement using indirect proof is equivalent to proving the contrapositive of the statement. If students are having trouble setting up indirect proofs, or even if they are not, it is a good idea to have them review conditional statements and the contrapositive. The first step to writing an indirect proof, can be to have them write out the contrapositive of the statement they want to prove. This will reduce confusion about what statement to start with, and what statement concludes the proof.

**Does This Really Prove Anything?** - Even after students have become adept with the mechanics of indirect proof, they may not be convinced that what they are doing really proves the original statement. This is the same as asking if the contrapositive is equivalent to the original statement. Using examples outside the field of mathematics can help students concentrate on the logic.

Start with the equivalence of the contrapositive. Does statement (1) have the same meaning as statement (2)?

- a. If you attend St. Peter Academy, you must wear a blue uniform.
- b. If you don't wear a blue uniform, you don't attend St. Peter Academy.

Let the students discuss the logic, and have them create and share their own examples.

If a good class discussion ensues, and the students provide many statements on a single topic, it may be possible to write some indirect proofs of statements not concerned with mathematics. This could be a good bonus assignment or project that when presented to the class will make the logic of indirect proof clearer for other students.



## 2.6 Polygons and Quadrilaterals

### Angles in Polygons

**All Those Polygons** - Although they have probably been taught it before, not all students will remember the names of the different polygons. There are not very many opportunities in life to use the word heptagon. Add these words to their vocabulary list.

This is most likely the first time they have been introduced to a polygon with a variable number of sides, an  $n$ -gon. This notation can be used when referring to a polygon that does not have a special name in common use, like a 19-gon. It can also be used when the number of sides of the polygon is unknown.

**Clockwise or Counterclockwise But Not Both** - At this point in the class, students are usually good at recognizing vertical angles. They will understand that the exterior angles made by extending the sides of the polygon in a clockwise rotation are congruent, at each vertex, to the exterior angle formed by extending the sides counterclockwise. What they will sometimes do is include both of these angles when using the Exterior Angle Sum theorem. Reinforce that the number of exterior angles is the same as the number of interior angles and sides, one at each vertex.

**Interior or Exterior** - Interior and exterior angles come in linear pairs. If one of these angles is known at a particular vertex, it is simple to find the other. When finding missing angles in a polygon, students need to decide from the beginning if they are going to use the interior or exterior sum. Most likely, if the majority of the known angle measures are from interior angles they will use the interior sum. They need to convert the exterior angle measures to interior angle measures before including them in the sum. If there are more exterior angle measures given, they can convert the interior angle measures and use the sum of  $360^\circ$ . It is important that they make a clear choice. They may mix the two types of angles in one summation if they are not careful.

**Do a Double Check** - Students often do not take the time to think about their answers. Going over the arithmetic and logic is one way to check work, but it is common to not recognize the error the second time either. A better strategy is to use other relationships to do the checking. In this lesson if the exterior sum was used, the work can be checked with the interior sum.

**What's the Interior Sum of a Nonagon Again?** - If students do not remember the interior sum for a specific polygon, and do not remember the formula, they can always convert to the exterior angle measures using the linear pair relationship. The sum of the exterior angles is always  $360^\circ$ . This strategy will work just as well as using the interior sum. Remind the students to be creative. When taking a test, they may not know an answer directly, but many times they can figure out the answer in an alternative way.

It is important to practice lots of problems like the following examples and to help students devise strategies to solve them.

Example 1: What is the measure of each interior angle of a regular  $n$ -gon if the sum of the interior angles is  $1080^\circ$ ?

Answer:  $135^\circ$  First the number of sides needs to be found, so set the sum equal to  $(n - 2)180^\circ$  and solve to find  $n = 8$ . Now the total of  $1080^\circ$  needs to be divided into 8 congruent angles:  $\frac{1080^\circ}{8} = 135^\circ$ .

Example 2: If three angles in a pentagon have measures  $115^\circ$ ,  $100^\circ$  and  $125^\circ$  what are the measures of the two remaining angles if they are congruent to each other?

Answer:  $100^\circ$  First we must determine the sum of the 5 angles in a pentagon:  $(5 - 2)180^\circ = 540^\circ$ . Next, subtract the three known angles from the sum:  $540^\circ - 115^\circ - 100^\circ - 125^\circ = 200^\circ$ . Finally, divide the remaining measure by

2 to get  $100^\circ$ .

Example 3: If the measure of one interior angle in a regular polygon is  $168^\circ$ , how many sides does it have?

Answer: 30 The easiest way to solve this problem is to use the exterior angle sum. If the interior angle measure is  $168^\circ$ , then the measure of each exterior angle is the supplement of this, or  $12^\circ$ . Now simply divide the exterior sum,  $360^\circ$  by  $12^\circ$  to get 30, the number of sides.

**Sketchpad Alternatives** - Many students become particularly engaged in a topic when they are able to investigate it while playing around with the computer. Here are a couple of ways to use Geometers' Sketchpad in the classroom as an alternative or supplement to direct instruction.

Angle Sum Conjecture – Have student make different convex polygons and measure the sum of their interior angles.

- The students should observe that for each type of polygon, no matter how many were drawn, they all have the same interior angle sum. They also like to see that if they change the shape of the convex polygon (by dragging a vertex- making sure it stays convex) that the sum remains the same.
- The students should drag a vertex of each polygon toward the center to create a concave polygon, and notice if the sum stays the same. (It won't.)
- Put the sums in order on the board:  $180^\circ, 360^\circ, 540^\circ, \dots$ . Ask the students to find the pattern in this sequence of numbers. Lead them to discovering the Angle Sum formula,  $(n - 2)180^\circ$  from the pattern.

Exterior Angle Sum Conjecture – Have student make different convex polygons and measure the sum of their exterior angles. Using Sketchpad to extend the sides of the polygon helps students gain an understanding of where the exterior angle is in relation to the polygon.

- Students should observe that the sum is always  $360^\circ$ , regardless of the number of sides. Doing this for polygons with different numbers of sides will help them see why the exterior angle sum remains the same.
- Students can again drag the vertex of a polygon and see that although the angles may change, the sum does not.

---

## Properties of Parallelograms

**Tree Diagram** - Most students will need practice working with the classification of quadrilaterals before they completely understand and remember all of the relationships. The Venn diagram is an important mathematical tool and should definitely be used to display the relationships among the different types of quadrilaterals. A tree diagram will also make an informative visual. Using both methods will reinforce the students' understanding of quadrilaterals, and their ability to make good diagrams.

**Parallel Line Properties** - In Chapter Three: Parallel and Perpendicular Lines, the students learn about the relationships between the measures of the angles formed by parallel lines and a transversal. Many of the quadrilaterals studied in this section have parallel sides. The students can apply what they learned in chapter three to the quadrilaterals in this chapter. They may have trouble seeing the relationships because instead of lines the quadrilaterals are made of segments. Recommend that the students draw the figures on their papers and extend the sides of the quadrilaterals so they can see all four angles made by the intersection of the lines. These angles will be useful when looking for specific information about the quadrilateral.

**Show Clear, Organized Work** - When using the distance or slope formula to verify information about a quadrilateral on the coordinate plane, students will often do messy scratch work as if they are the only ones that will need to read it. In this situation, the work is a major part of the answer. They need to communicate their thoughts on the situation. They should write as if they are trying to convince the reader that they are correct. As students progress in their study of mathematics, this is more often the case than the need for a single numerical answer. They should start developing good habits now.

**Symmetry** - Most students have already studied symmetry at some point in their education. A review here may be in order. When studying quadrilaterals, symmetry is a good property to consider. Symmetry is also important when discussing the graphs of key functions that the students will be studying in the next few years. It will serve the students well to be adept in recognizing different types of symmetry.

---

## Proving Quadrilaterals are Parallelograms

**Proofs Using Congruent Triangles** - The majority of the proofs in this section use congruent triangles. The quadrilateral of interest is somehow divided into triangles that can be proved congruent with the theorems and postulates of the previous chapters. Once the triangles are known to be congruent, the definition of congruent triangles ensures that certain parts of the quadrilateral are also congruent. Students should be made aware of this pattern if they are having difficulty writing or understanding the proofs of the properties of various quadrilaterals. If they are still struggling they should spend some time reviewing Chapter Four: Triangles and Congruence.

**The Diagonals of Parallelograms** - The properties concerning the sides and angles of parallelograms are fairly intuitive, and students pick them up quickly. More emphasis should be placed on what is known, and not known about the diagonals. Students frequently try to use the incorrect fact that the diagonals of a parallelogram are congruent. Rectangles are the focus of an upcoming lesson, but demonstrating to students that the diagonals of a quadrilateral are only congruent in the special case where all the angles of the parallelogram are congruent. For a general parallelogram, the diagonals bisect each other. This can be shown nicely using a sketch in Geometer's Sketchpad.

**Proof Practice** - The proofs in this section may seem a bit repetitive, but students will benefit from practicing these proofs since they review important concepts learned earlier in the course. To avoid losing the students' attention, find different ways of presenting the proofs. One idea is to divide the students into groups, and have each group demonstrate a different proof to the class.

**Parallel or Congruent** - When looking at a marked figure students will sometimes see the arrows that designate parallel segments and take that the segments to be congruent. This could be due to the misreading of the marks, or mistakenly thinking parallel always implies congruence. Warn students not to make this error. The last method of proof in this section which utilizes that one pair of sides are both congruent and parallel, along with an example of a trapezoid where the parallel sides are not congruent, will help students remember the difference.

Below are some additional examples to be shown in class.

Example 1: Quadrilateral  $ABCD$  is a parallelogram.  $AB = 2x + 5$ ,  $BC = x - 3$  and  $DC = 3x - 10$ . Find the measures of all four sides of the quadrilateral.

Answer:  $AB = CD = 35$  and  $BC = AD = 12$ .

Encourage students to draw and label a diagram for problems such as these. Remind them that the name of a polygon lists the vertices in a circular order. This will help ensure that they match up correct pairs of congruent sides. Set the congruent sides equal to each other and solve for  $x$ .

$$\begin{aligned}2x + 5 &= 3x - 10 \\ x &= 15\end{aligned}$$

Example 2:  $JACK$  is a parallelogram.  $m\angle A = (10x - 60)^\circ$  and  $m\angle C = (2x + 45)^\circ$ . Find the measures of all four angles.

Answer:  $m\angle C = m\angle J = 77.5^\circ$  and  $m\angle A = m\angle K = 102.5^\circ$

Again, encourage students to sketch and label a diagram so they can see that  $\angle A$  and  $\angle C$  are consecutive angles in

the parallelogram and therefore supplementary. Now, they can set the sum of the expressions for the measures of these two angles equal to  $180^\circ$  and solve for  $x$ .

$$10x - 60 + 2x + 45 = 180^\circ$$

$$x = 16\frac{1}{4}$$

Example 3: *KATE* is a parallelogram with a perimeter of 40 cm.  $KA = 3x + 8$  and  $AT = x + 4$ . Find the length of each side.

Answer:  $KA = ET = 14$  cm and  $AT = KE = 6$  cm

After sketching a diagram, students should recognize that  $KA$  and  $AT$  are adjacent sides and therefore not necessarily congruent. Remind them that they were given the perimeter and help them figure out that they need to add two times each of the given side length expressions and set this sum equal to the perimeter of the parallelogram as shown below.

$$2(3x + 8) + 2(x + 4) = 40$$

$$x = 2$$

Example 4: *SAMY* is a parallelogram with diagonals intersecting at point  $X$ .  $SX = x + 5$ ,  $XM = 2x - 7$  and  $AX = 12x$ . Find the length of each diagonal.

Answer:  $SM = 34$  cm and  $AY = 288$  cm

Students should use the fact that diagonals bisect each other in a parallelogram to solve this one. By setting the two parts of diagonal  $SM$  each to each other they can find  $x$  and then solve for the lengths of the diagonals.

$$x + 5 = 2x - 7$$

$$x = 12$$

Example 5: *JEDI* is a parallelogram.  $m\angle J = 2x + 60$  and  $m\angle D = 3x + 45$ . Find the measures of the four angles of the parallelogram. Does this parallelogram have a more specific categorization?

Answer: All four angles measure  $90^\circ$ . *JEDI* is a rectangle.

The angles given here are opposite angles. By setting them equal we can solve for  $x$  and find the angle measures.

$$2x + 60 = 3x + 45$$

$$x = 15$$

## Rectangles, Rhombuses and Squares

**The Power of the Square** - Students should know by the classification of quadrilaterals that all the theorems for parallelograms, rectangles, and rhombuses, also apply to squares. It is a good idea to talk about this in class though in case they have not put it together on their own. These theorems and the definition of a square can be combined to from some interesting exercises.

### 2.6. POLYGONS AND QUADRILATERALS

A Venn diagram can be used to show the relationships between the figures and their properties. This is also an excellent opportunity to review some logic and practice making conditional statements and checking their validity based on the Venn diagram. For example: If the quadrilateral is a square, then it is a parallelogram. This statement is true, but its converse is false.

**Information Overload** - Quite a few theorems are presented in this chapter. Remembering them all and which quadrilaterals they apply to can be a challenge for students. If they are unsure, and cannot check reference material, a test case can be drawn. For example: Do the diagonals of a parallelogram bisect the interior angles of that parallelogram? First they need to draw a parallelogram that clearly does not fit into any subcategory. It should be long and skinny, so no rhombi properties are mistakenly attributed to it. It should also be well slanted over, so as not to be mistaken for a rectangle. Now they can draw in the diagonals. It will be obvious that the diagonals are not bisecting the interior angles. They could also try to recreate the proof, but that will probably be more time consuming and it requires a bit of skill.

Also, students need to be reminded that they must show that the quadrilateral is a parallelogram before it can be determined that it is one of the special parallelograms. For example, just because the diagonals of the quadrilateral are congruent, it is not sufficient information to conclude the quadrilateral is a rectangle- it could be an isosceles trapezoid. If students can also show that one of the properties of parallelograms is true for the quadrilateral as well, such as opposite sides are parallel, then they can correctly conclude that the quadrilateral is a rectangle.

Example 1:  $SQUR$  is a square and  $X$  is the point where the diagonals meet.  $QX = 3x - 9$  and  $SX = 2x$ . Find the length of both diagonals.

Answer:  $SU = QR = 36$ .

Since the diagonals in a square are equal and bisect each other, we can set  $3x - 9 = 2x$  and solve to get  $x = 9$ . Then  $QX = 18$  and both diagonals are 36.

Example 2:  $DAVE$  is a rhombus with diagonals that intersect at point  $X$ .  $DX = 3$  cm and  $AX = 4$  cm. How long is each side of the rhombus?

Answer:  $DA = AV = VE = ED = 5$  cm

The diagonals of a rhombus are perpendicular bisectors of each other so  $DX$  and  $AX$  are the legs of a right triangle. The hypotenuse of this right triangle is a side of the rhombus and is 5 cm by Pythagorean Theorem.

---

## Trapezoids and Kites

**Average for the Median** - Students who have trouble memorizing formulas may be intimidated by the formula for the length of the median of a trapezoid. Inform them that they already know this formula; it is just the average. The application of the formula makes sense, the location of the median is directly between the two bases, and the length of the median is exactly between the lengths of the bases. They will have no problem finding values involving the median.

**Where Are We?** - It is easy for students to forget how what they are learning today relates to the chapter and to the class. Use the Venn diagram of the classification of quadrilaterals to orient them in the chapter. They are no longer learning about parallelograms, but have moved over to the separate trapezoid area. When students are able to organize their new knowledge, they are better able to retain and apply it.

**Does it have to be Isosceles?** - Students may have trouble remembering which theorems in this section apply only to isosceles trapezoids. Note that base angle, and diagonal congruence apply only to isosceles trapezoids, but the relationship of the length of the median to the bases is the same for all trapezoids.

Example 1:  $TRAP$  is a trapezoid. The median has length 4 cm, and one of the bases has length 7 cm. What is the length of the other base?

Answer: 1 cm

There are two ways to approach this problem. One is to compare differences – seven is three more than four, so the other base must be three less than four. The second way is to set up and solve an equation as shown below.

$$4 = \frac{7+x}{2}$$

$$x = 1$$

Example 2:  $WXYZ$  is a trapezoid. The length of one base is twice the length of the other base, and the median is 9 cm. How long is each base?

Answer: The bases are 6 cm and 12 cm.

This problem can be solved by allowing one base to be  $x$  and the other base to be  $2x$ . Then solve the following equation:

$$\frac{x+2x}{2} = 9$$

$$x = 6$$

**Only One Congruent Set** - It is important to note that in a kite, only one set of interior angles are congruent, and only one of the diagonals is bisected. Sometimes students struggle with identifying where these properties hold. It is the nonvertex angles that are congruent, and the diagonal connecting the nonvertex angles that is bisected. The single line of symmetry of a kite shows both these relationships. Remind students to think of this line of symmetry and what it tells them about congruent pairs of angles and segments.

**Break it Up** - When working with a kite, it is sometimes easier to think of it as two isosceles triangles, or four right triangles, instead of one quadrilateral.

At this point in the class, students have had extensive experience working with isosceles triangles, and can easily apply the Base Angle theorem to see that the nonvertex angles of the kite are congruent. They have also seen that the diagonal segment between the vertex angles creates many symmetries in the triangle. If students think of the symmetries in the triangle, it will make sense to them that the vertex angles are bisected and that the diagonal connecting the nonvertex angles is bisected.

They can also think of a kite as four right triangles. This will help them remember that the diagonals are perpendicular, and remind them that the Pythagorean Theorem can be used to find missing segment measures. Noticing that the right triangles are in two congruent sets will help them identify congruent segments and angles.

Example 1:  $KITE$  is a kite with  $\overline{KE} \cong \overline{KI}$ . Prove that  $\triangle KSE \cong \triangle KSI$ .

Answer:

**TABLE 2.4:**

Statement	Reason
$\overline{KE} \cong \overline{KI}$	Given
$\overline{ES} \cong \overline{SI}$	Kite Diagonal Theorem
$\angle KSE$ and $\angle KSI$ are right angles	Definition of Perpendicular
$\angle KSE \cong \angle KSI$	Right Angle Theorem
$\triangle KSE \cong \triangle KSI$	HL

## 2.7 Similarity

### Ratios and Proportions

**Keep it in Order** - When writing a ratio, the order of the numbers is important. When the ratio is written in fraction form the amount mentioned first goes in the numerator, and the second number goes in the denominator. Remind the students it is important to keep the values straight to avoid confusion or misunderstandings. For example, if they are looking at a college and see that the male to female ratio is 11 to 12, it is important to know which one comes first to interpret the ratio correctly.

**To Reduce or Not to Reduce** - When a ratio is written in fraction form it can be reduced like any other fraction. This will often make the arithmetic simpler and is frequently required by instructors for fractions in general. But when reducing a ratio, useful information can be lost. If the ratio of girls to boys in a classroom is 16 to 14, it may be best to use the fraction  $\frac{16}{14}$  because it gives the total number of students in the class where the reduced ratio  $\frac{8}{7}$  does not.

**Consistent Proportions** - A proportion can be correctly written in many ways. As long as the student sets up the ratios in a consistent, orderly fashion, they will most likely have written a correct proportion. There should be a common tie between the two numerators, the two denominators, the numbers in the first ratio, and the numbers in the second ratio. They should think about what the numbers represent, and not just use them in the order given in the exercise, although the numbers are often given in the correct order.

Example: Victor got a new hybrid. He went 525 gallons on the first five gallons that came with the car. He just put 12 gallons in the tank. How far can he expect to go on that amount of gas?

Answer:  $\frac{25}{5} = \frac{x}{12}$ , so  $x = \frac{12 \cdot 25}{5}$  and Victor can expect to go 1,260 miles.

Note: Students may be tempted to put the 12 in the numerator of the second ratio because it was the third number given in the exercise, but it should go in the denominator with the other amount of gas.

**The Fraction Bar is a Grouping Symbol** - Students know that parenthesis are a grouping symbol and that they need to distribute when multiplying a number with a sum or difference. A fraction bar is a more subtle grouping symbol that students frequently overlook, causing them to forget to distribute. To help them remember have them put parenthesis around sums and differences in proportions before they cross-multiply.

Example:  $\frac{x+3}{5} = \frac{x-8}{7}$  becomes  $\frac{(x+3)}{5} = \frac{(x-8)}{7}$

**Everybody Loves to Cross-Multiply** - There is something satisfying about cross-multiplying and students are prone to overusing this method. Remind them that cross-multiplication can only be used in proportions, when two ratios are equal to each other. It is not appropriate to cross-multiply when two fractions are being added, subtracted, multiplied or divided. It might be helpful to do some example of these to illustrate the difference and discuss the difference between “cross multiplication” and “multiplying across.”

Examples: Cross multiply here:  $\frac{3}{4} = \frac{10}{x}$  or  $\frac{x+1}{7} = \frac{8}{x}$

Don't cross multiply here:  $\frac{3}{4} + \frac{10}{x}$  or  $\frac{x+1}{7} \div \frac{8}{x}$

**Only Cancel Common Factors** - When reducing a fraction or putting a ratio in simplest terms, students often try to cancel over an addition or subtraction sign. This problem occurs most frequently when students work with fractions that contain variable expressions. To combat this error, go back to numerical examples. Students will see that what they are doing does not make sense when the variables are removed. Then go back to example with variables.

Hopefully the students will be able to carry over the concept.

Examples: Can be reduced:  $\frac{3 \cdot 2}{5 \cdot 2} = \frac{3}{5}$  and  $\frac{3(x-4)}{3 \cdot 2} = \frac{(x-4)}{2}$

Can't be reduced:  $\frac{3+2}{5+2} \neq \frac{3}{5}$  and  $\frac{(x-4)}{4} \neq x - 1$

---

## Similar Polygons

**A Common Vocabulary Error** - Students frequently interchange the words proportional and similar. Remind them that proportional describes a relationship between numbers, and similar describes a relationship between figures. You can relate this difference in definition back to the difference between the terms equal and congruent.

**Compare and Contrast Similar with Congruent** - If your students have already learned about congruent figures, now would be a good time to review. The definitions of congruent and similar are very close. Ask the students if they can identify the difference; it's only one word. You can also point out that congruent is a subset of similar like square is a subset of rectangle, or mother is a subset of women. Understanding the differences between congruent and similar will be important in upcoming lessons when proving triangles similar.

**Use that Similarity Statement** - In some figures, which sides of similar polygons correspond is obvious, but when the polygons are almost congruent, or oriented differently, the figure can be misleading. Students usually begin by using the figure and then forget to use the similarity statement when necessary. Remind them about this information as they start working on more complicated problems. The similarity statement is particularly useful for students that have a hard time with visual-spatial processing. It is a good idea to do several examples in which students are "forced" to use the similarity statement to align the correct sides and angles to get them in the habit of using the similarity statement rather than their "eyes."

**Who's in the Numerator** - When writing a proportion students sometimes carelessly switch which polygon's measurements are in the numerator. To help students avoid this pitfall, I tell the students to choose right from the beginning and BE CONSISTENT throughout the problem. When it comes to writing proportions if the students focus on being orderly and consistent, they will usually come up with a correct setup.

**Bigger or Smaller** - After completing a problem it is always a good idea to take a minute to decide if the answer makes sense. This is hard to get students to do. When using a scale factor, a good way to check that the correct ratio was used is to notice if the number got bigger or smaller. Is that what we expected to happen?

**Update the List of Symbols** - In previous lessons it has been recommended that students create a reference page in their note books that contains a list of all the symbols and how they are being used in this class. Students should add the symbol for similar to the list, and take few minutes to compare it to the symbols they already know. Sometimes students will read the similarity symbol as "approximately equal". It is standard to use two wavy lines for approximately equal and one wavy line for similar, but this is not always the case.

---

## Similarity by AA

**Definition of Similar Triangles vs. AA Shortcut** - Let the students know what a deal they are getting with the AA Triangle Similarity Postulate. The definition of similar polygons requires that all three corresponding pairs of angles be congruent, and that all three pairs of corresponding sides are proportional. This is a significant amount of information to verify, especially when writing a proof. The AA postulate is a significant shortcut; only two piece of information need to be verified and all the rest comes for free. When students see how much this reduces the work, they will be motivated to understand the proof and will enjoy using the postulate. Everybody likes to use a tricky shortcut. A fun activity to explore this concept would be to have students create a triangle with three given angle measures. Then, in pairs, compare the lengths of corresponding sides to discover that they are indeed similar. Then



ask students if they really needed to be told the third angle measure? This process should help them remember AA Similarity and help reinforce the idea that AA does not ensure congruent triangles.

**Get Some Sun** - It is always a good idea to create some variety in the class. It will keep students' minds active. Although it is time consuming, get some yard sticks and take the students outside to measure a tree or a flagpole using their shadows and similar triangles. Have them evaluate their accuracy. They will have to measure carefully if they are to get a reasonable numbers. This will give them some practice using a ruler and converting units. The experience will also help them put what they are learning about similar triangles into their long term memory.

**Trigonometry** - Let the students know that the next chapter is all about trigonometry, and that the AA Triangle Similarity Postulate is what make trigonometry possible. Mentioning what is to come will start to prepare their minds and make learning the material in the next chapter that much easier. Here are some problems that involve similar right triangles to accustom the students to this new branch of mathematics.

Example 1:  $\triangle ABC$  is a right triangle with right angle  $C$  and  $\triangle ABC \sim \triangle XYZ$ . Which angle in  $\triangle XYZ$  is the right angle?

Answer:  $\angle Z$

Example 2:  $\triangle CAT \sim \triangle DOG$  with right angle at  $A$ . If  $CA = 5$  cm,  $CT = 13$  cm and  $DO = 15$  cm, what is the length of  $\overline{OG}$ ?

Answer: 36 cm

There is more than one step required to solve this problem. Students must use the Pythagorean theorem and the definition of similar polygons. First, the ratio between the figures is determined by  $\frac{CA}{DO} = \frac{5}{15} = \frac{1}{3}$ . Next, we need the length of  $\overline{AT}$  since it corresponds to  $\overline{OG}$ . Using the Pythagorean Theorem gives us  $AT = 12$  cm. Now we can set up the proportion  $\frac{1}{3} = \frac{12}{x}$  and solve it to get  $x = 36$ .

## Similarity by SSS and SAS

**The S of a Triangle Similarity Postulate** - At this point in the class, students have shown that a significant number of triangles are congruent. They have learned the process well. When teaching them to show that triangles are similar, it is helpful to build on what they have learned. The similarity postulates have S's and A's just like the congruence postulates and theorems. The A's are treated exactly the same in similarity postulates as they were in congruence theorems. Each A in a similarity shortcut stands for one pair of congruent corresponding angles in the triangles.

The S's represent a different requirement in similarity postulates than they did in congruence postulates and theorems. Congruent triangles have congruent sides, but similar triangles have proportional sides. Each S in a similarity postulate represents a ratio of corresponding sides. Once the ratios (two for SAS and three for SSS) are written, equality of the ratios must be verified. If the ratios are equal, the sides in question are proportional, and the postulate can be applied.

It is sometimes hard for student to adjust to this new side requirement. They have done so much work with congruent triangles that it is easy for them to slip back into congruent mode. Warn them not to fall into the old way of thinking.

### Triangle Congruence Postulates and Theorems Triangle Similarity Postulates

S → congruent sides    S → proportional sides

SSS                      AA

SAS                      SSS

ASA                      SAS

AAS

HL

**Only Three Similarity Postulates** - Students will sometimes try to use ASA, or other congruence theorems to show that two triangles are similar. Bring it to their attention that there are only three postulates for similarity, and that they do not all have the same side and angle combinations as congruence postulates or theorems. It may help them to show them that the Congruence Postulates ASA and AAS are both “represented” by the Similarity Postulate AA.

## Proportionality Relationships

**Similar Triangles Formed by an Interior Parallel Segment** - Students frequently are presented with a triangle that contains a segment that is parallel to one side of the triangle and intersects the other two sides. This segment creates a smaller triangle in the tip of the original triangle. There are two ways to consider this situation. The two triangles can be considered separately, or the Triangle Proportionality Theorem can be applied.

(1) Consider the two triangles separately.

The original triangle and the smaller triangle created by the parallel segment are similar as seen in the proof of the Triangle Proportionality theorem. One way students can tackle this situation is to draw the triangles separately and use proportions to solve for missing sides. The strength of this method is that it can be used for all three sides of the triangles. Students need to be careful when labeling the sides of the larger triangle; often the lengths will be labeled as two separate segments and the students will have to add to get the total length.

(2) Use the Triangle Proportionality theorem.

When using this theorem it is much easier to setup the proportions, but there is the limitation that the theorem cannot be used to find the lengths of the parallel segments.

Ideally, students will be able to identify the situations where each method is the most efficient, and apply it. This may not happen until the students have had some experience with these types of problems. It is best to have students use method (1) at first, then after they have worked a few exercises on their own, they can use (2) as a shortcut in the appropriate situations.

Make sure to do many examples where students need to use the similar triangles to solve for one of the parallel segments. Combining this requirement in the same problem where the shortcut can be utilized is especially helpful for them to begin recognizing the difference.

Example:  $\triangle ABC$  has point  $E$  on  $\overline{AB}$  and  $F$  on  $\overline{BC}$  such that  $\overline{EF} \parallel \overline{AC}$ . Given  $AE = 5\text{ cm}$ ,  $EB = 3\text{ cm}$ ,  $BF = 4\text{ cm}$  and  $AC = 10\text{ cm}$ , find  $EF$  and  $FC$ .

$$\text{Answer: } \frac{3}{8} = \frac{EF}{10}, EF = 3\frac{3}{4}\text{ cm}$$

$$\frac{3}{5} = \frac{4}{FC} \text{ or } \frac{3}{8} = \frac{4}{FC+4}, FC = 6\frac{2}{3}\text{ cm}$$

Encourage students to draw a diagram and label it with the given lengths. Next, they may wish to draw the two similar triangles separately to better visualize which parts correspond.

**Proportions with Angle Bisectors** - Students have a hard time with this one because the two triangles formed by the angle bisector are not similar. Students need to see lots of examples to get this one straight. Remind them that this proportion is true only when the segment is an angle bisector- it is not necessarily true for altitudes or medians in the triangle.

## Similarity Transformations

**Apostrophe vs Prime** - When a geometric figure is transformed (by translation, rotation, dilation, etc.) the image is denoted using the “prime” marking. For example, if  $\triangle ABC$  is transformed, the image is denoted by  $\triangle A'B'C'$ .

**Scale Factor Compared to Segment and Area Ratios** - When a polygon is dilated using scale factor,  $k$ , the ratio of the image of the segment to the original segment is  $k$ . This is true for the sides of the polygon, all the special segments of triangles studied in chapter five, and the perimeter of the polygon. The relationship holds for any linear measurement. Area is not a linear measurement and has a different scale factor. The ratio of the area of the image to the area of the original polygons is  $k^2$ . Students frequently forget to square the scale factor when working with the ratios of a figure and its image. This concept will be explored further in Chapter 10: Perimeter and Area, but the idea can be introduced here.

Example:  $\triangle ABC$  has coordinates  $A(1, 13)$ ,  $B(6, 1)$  and  $C(1, 1)$ . Complete the following:

- Graph  $\triangle ABC$ .
- Use the distance formula to find the length of each side of  $\triangle ABC$ .
- Calculate the perimeter of  $\triangle ABC$ .
- Calculate the area of  $\triangle ABC$ .
- $\triangle A'B'C'$  is the image of  $\triangle ABC$  under a dilation centered at the origin with scale factor 3. Graph  $\triangle A'B'C'$ .
- Calculate the perimeter of  $\triangle ABC$ .
- Calculate the area of  $\triangle A'B'C'$ .
- Compare  $\triangle A'B'C'$  to  $\triangle ABC$ . What is the ratio of each set of corresponding side lengths, the perimeters and the areas? What do you notice when these ratios are compared to the scale factor?

Answers:

- Graph
- $AC = 12, BC = 5, AB = 13$
- 30
- 30
- Graph
- $AC = 36, BC = 15, AB = 39$
- 90
- 270
- The ratios of the side lengths and the perimeter are 3:1, the same ratio as the scale factor. The ratio of the areas is 9:1, the square of the scale factor.

---

## Extension: Self-Similarity

**More Complex Fractals** – Students need to begin learning about fractals with the simple examples given in the text. Once they have taken some time to work with, and understand the self-similar relationship, it is amazing to see how complex and beautiful fractals can become. Numerous examples of exquisite fractals can be found on-line. If you are lucky enough to have access to computers and a projector, have the students search for fractals and choose their favorite to share with the class. Student will begin to realize the importance of what there are learning when they see what a huge ocean they are dipping their toe into.

**Applications** - Many students need to know how a subject is useful before they are motivated to spend time and energy learning about it. Throughout the text there have been references to modeling and how mathematical concepts often need to be adjusted to fit the world around us. Fractals are used to model many aspects of nature including tree branches, shells, and the coast line. Knowing of the applications of fractals motivates students. If time permits give a more in-depth explanation, or use this topic to assign research projects.

**Video Time** - Self-similarity and fractals make up an extremely complex visual topic. There are many videos in common use that can give a much more exciting and attention grabbing explanation than most teachers can deliver while standing in front of the classroom. These videos are not hard to come by, and they give an excellent explanation

of the material. It is a nice change of pace for the students, and make help them develop some genuine interest in the subject of mathematics.

**Create Your Own Fractal** - Having the students create their own fractal outside of class is a fun, creative project. This gives the more artistically minded students an opportunity to shine in the class, and the products make beautiful wall decorations. Here are some guidelines for the assignment.

- a. The fractal should fill the top half of a piece of  $8\frac{1}{2} \times 11$  inch plain white paper turned vertically. To give them more space, provide them with legal size paper. Be aware that each student will probably require more than one piece before they create their final product.
- b. The fractal should be boldly colored to accentuate the self-similarity.
- c. The students should be encouraged to be creative and original in their design.
- d. The bottom half of the paper will have a paragraph explaining the self-similarity in the fractal. They should explain why their design is a fractal.
- e. Create a rubric to give to the students at the time the project is assigned so that they will feel like they are being graded fairly. It is hard to evaluate artwork in a way that everyone feels is objective.

## 2.8 Right Triangle Trigonometry

### The Pythagorean Theorem

**Reducing Radicals** - Students may or may not have spent much time reducing radicals in previous math courses. You may need to review how to do this and how to perform operations with radicals. Students may need to see more than one way to reduce radicals. The most common is to take out the greatest factor which is a perfect square, but this can be difficult for many students with weak mental math skills. Another method is to make a factor tree and find the prime factorization of the number and identify doubles that can be taken out. There is not necessarily a “best” way, it is more important to figure out which way your students can best reduce radicals correctly.

Method 1:  $\sqrt{72} = \sqrt{36 \times 2} = 6\sqrt{2}$

Method 2:  $\sqrt{72} = \sqrt{9 \times 8} = \sqrt{3 \times 3 \times 2 \times 2 \times 2} = 3 \times 2\sqrt{2} = 6\sqrt{2}$

The following are some examples that will help students review the basic properties of radicals and practice reducing radicals.

Example 1:  $\sqrt{112}$

Answer:  $\sqrt{16 \times 7} = 4\sqrt{7}$

Students may not recognize right away that 16 is a factor of 112. This problem can also be solved by completely factoring 112 (method 2).

Example 2:  $4\sqrt{192}$

Answer:  $4\sqrt{64 \times 3} = 4 \times 8\sqrt{3} = 32\sqrt{3}$

Example 3:  $2\sqrt{5} + \sqrt{45}$

Answer:  $2\sqrt{5} + 3\sqrt{5} = 5\sqrt{5}$

Review with students that in order to add or subtract radicals, the radical must be identical. Sometimes they can meet this condition by simplifying one or both terms and sometimes they just won't be able to add them together.

Example 4:  $\sqrt{6} \times \sqrt{18}$

Answer:  $\sqrt{108} = \sqrt{36 \times 3} = 6\sqrt{3}$

Students may have forgotten that radicals can be multiplied or divided to form a new radical which they may then be able to reduce.

Example 5:  $(\sqrt{11})^2$

Answer: 11

Review the definition of a square root with students to help them understand this one. The square root and the square cancel each other out - they are inverse operations.

**Skipping Around** - Not all texts present material in the same order, and many instructors have a preferred way to develop concepts that is not always the same as the one used in the text. The Pythagorean theorem is frequently moved from place to place. You should follow the link given in the text to see additional proofs of the Pythagorean Theorem. Proofs are hard for most students to understand. It is important to choose one that the students can feel good about. Don't limit the possibilities to these two, research other methods, and pick the one that is most

appropriate for your class. Or better yet, pick the best two or three. Different proofs will appeal to different students.

**The Height Must be Measured Along a Segment That is Perpendicular to the Base** - When given an isosceles triangle where the altitude is not explicitly shown, student will frequently try to use the length of one of the sides of the triangle for the height. Tell them that they must find the length of the altitude that is perpendicular to the segment that's length is being used for the base in the formula  $A = \frac{1}{2}bh$ . Sometimes they do not know what to do, and are just trying something, which is, in a way, admirable. The more common explanation though is that they forget. The students have been using this formula for years, they think they know this material, so they just plug and chug, not realizing that the given information has changed. Remind the students that now that they are in Geometry class, there is an extra step. The new challenge is to find the height, and then they can do the easy part and plug it into the formula.

**Derive the Distance Formula** - After doing an example with numbers to show how the distance formula is basically just the Pythagorean theorem, use variables to derive the distance formula. Most students will understand the proof if they have seen a number example first. Point out to the students that the number example was inductive reasoning, and that the proof was deductive reasoning. Taking the time to do this is a good review of logic and algebra as well as great proof practice.

**Squaring a Negative** - One of the most common errors students make when using the distance formula is that they use their calculator incorrectly when squaring negative numbers. Remind students that when they square a negative number, the result is positive. Describe the difference between  $-8^2$  and  $(-8)^2$  and review the correct order of operations. You may also want to stress the connection between the distance formula and the Pythagorean theorem and encourage them to think of the difference between the  $x$ 's and  $y$ 's as lengths and therefore they can just use the absolute value of the difference (i.e. ignore the negative).

---

## Converse of the Pythagorean Theorem

**Acute and Obtuse Triangles** - Many students have trouble remembering that the inequality with the greater than is true when the triangle is acute, and that the equation with the less than is true for obtuse triangles. It seems backwards to them. One way to present this relationship is to compare the longest side and the angle opposite of it. In a right triangle, the equation has an equal sign; the hypotenuse is the perfect size. When the longest side of the triangle is shorter than what it would be in a right triangle, the angle opposite that side is also smaller, and the triangle is acute. When the longest side of the triangle is longer than what it would be in a right triangle, the angle opposite that side is also larger, and the triangle is obtuse.

**Is It Really a Triangle?** - I have found that once students start using the Pythagorean theorem to determine whether lengths form a right, acute or obtuse triangle that they forget completely that the sum of two sides must be greater than the remaining side in order for a triangle to exist at all. The following example illustrates this misunderstanding. You may want to put it on the board and ask your students what kind of triangle is formed.

Example: What kind of triangle is formed by lengths 3, 4, 7?

Answer: None! There is no triangle at all.  $3 + 4 = 7$ .

If students used the Pythagorean theorem and didn't check to make sure there was a triangle at all then they would have said that the triangle is obtuse. This is incorrect.

---

## Using Similar Right Triangles

**Separate the Three Triangles** - The altitude from the right angle of a triangle divides the triangle into two smaller right triangles that are similar to each other, and to the original triangle. All the relationships among the segments

in this figure are based on the similarity of the three triangles. Many students have trouble rotating shapes in their minds, or seeing individual polygons when they are overlapping. It is helpful for these students to draw the triangles separately and oriented in the same direction. After going through the process of turning and redrawing the triangles a few times, they will remember how the triangles fit together, and this step will no longer be necessary.

**Color-Coded Flashcards** - It is difficult to describe in words which segments to use in the geometric mean to find the desired segment. Labeling the figure with variables and using a formula is the standard method. The relationship is easier to remember if the labeling of the triangles is kept the same every time the figure is drawn. The students need to remember the location of the segments relative to each other. Making color-coded pictures or flashcards will be helpful. For each relationship the figure should be drawn on both sides of the card. The segment whose measure is to be found should be highlighted in one color on the front, and on the back, the two segments that need to be used in the geometric mean should be highlighted with two different colors. Using two colors on the back is important because the segments often overlap. Making these cards will be helpful even if the students never use them. Those that have trouble remembering the relationship will use these cards frequently as a reference.

**Add a Step and Find the Areas** - The exercises in this section have the students find the base or height of triangles. They have all the information that they need to also calculate the areas of these triangles. Students need practice with multi-step problems. Having them find the area will help them think through a more complex problem, and give them practice laying out organized work for calculations that are more complex. Chose to extend the assignment or not based on how well the students are doing with the material, and how much time there is to work on this section.

---

## Special Right Triangles

**Memorize These Ratios** - There are some prevalent relationships and formulas in mathematics that need to be committed to long term memory, and the ratios made by the sides of these two special right triangles are definitely among them. Students will use these relationships not only in the rest of this class, but also in trigonometry, and in other future math classes. Students are expected to know these relationships, so the sooner they learn to use them and commit them to memory, the better off they will be.

**Two is Greater Than the Square Root of Three** - One way that students can remember the ratios of the sides of these special right triangles, is to use the fact that in a triangle, the longest side is opposite the largest angle, and the shortest side is opposite the smallest angle. At this point in the class, students know that the hypotenuse is the longest side in a right triangle. What sometimes confuses them is that in the 30-60-90 triangle, the ratio of the sides is  $1 : 2 : \sqrt{3}$ , and if they do not really think about it, they sometimes put the  $\sqrt{3}$  as the hypotenuse because it might seem bigger than 2. Using the opposite relationship is a good method to use when working with these triangles. Just bring to the students' attention that  $2 > \sqrt{3}$ .

**How Do I Find the Short Leg Again?** - While students may quickly memorize the two special right triangle ratios, they may have trouble applying the ratios to find the unknown sides. One way to help students with this process is to have them write the ratios with a variable. For example the 30-60-90 triangle ratio would be  $x : 2x : x\sqrt{3}$ . Next, have them identify which side they are given and use the appropriate part of the ratio to determine  $x$  and the other side.

Example 1: Find the other two sides in a 30-60-90 triangle given that the hypotenuse is 8.

Answer: First set  $2x = 8$  and solve to get  $x = 4$  which is the short leg. The long leg is then  $4\sqrt{3}$ .

Example 2: Find the length of a leg in an isosceles right triangle with hypotenuse 3.

Answer: The ratio for an isosceles right triangle or 45-45-90 triangle is  $x : x : x\sqrt{2}$ . Since we are given the hypotenuse here,  $x\sqrt{2} = 3$ . Now we must solve for  $x$  as shown below.

$$\frac{x\sqrt{2}}{\sqrt{2}} = \frac{3}{\sqrt{2}}$$

$$x = \frac{3}{\sqrt{2}} \times \frac{\sqrt{2}}{\sqrt{2}} = \frac{3\sqrt{2}}{2}$$

**Rationalizing the Denominator** - Sometimes student will not recognize that  $\frac{1}{\sqrt{2}}$  and  $\frac{\sqrt{2}}{2}$  are equivalent. Most likely, they learned how to rationalize denominators in algebra, but it is nice to do a short review before using these types of ratios in special right triangles.

**Derive with Variables** - The beginning of the last chapter offers students a good amount of experience with ratios. If they did well on those sections, it would benefit them to see the derivation of the ratios done with variable expressions. It would give them practice with a rigorous derivation, review and apply the algebra they have learned, and help them see how the triangles can change in size.

**Exact vs. Decimal Approximation** - Many students do not realize that when they enter  $\sqrt{2}$  into a calculator and get 1.414213562, that this decimal is only an approximation of  $\sqrt{2}$ . They also do not realize that when arithmetic is done with an approximation, that the error usually grows. If 3.2 is rounded to 3, the error is only 0.2, but if the three is now multiplied by five, the result is 15, instead of the 16 it would have been if original the original number had not been rounded. The error has grown to 1.0. Most students find it more difficult to do operations with radical expressions than to put the numbers into their calculator. Making them aware of error magnification will motivate them to learn how to do operations with radicals. In the last step, it may be nice to have a decimal approximation so that the number can be easily compared with other numbers. It is always good to have an exact form for the answer so that the person using your work can round the number to the desired degree of accuracy.

## Tangent, Sine and Cosine

**Trig Thinking** - Students sometimes have a difficult time understanding trigonometry when they are first introduced to this new branch of mathematics. It is quite a different way of thinking when compared to algebra or even geometry. Let them know that as they begin their study of trigonometry in the next few sections the calculations won't be difficult, the challenge will be to understand what is being asked. Sometimes students have trouble because they think it must be more difficult than it appears to be. Most students find they like trigonometry once they get the feel of it.

**Ratios for a Right Angle** - Students will sometimes try to take the sine, cosine or tangent of the right angle in a right triangle. They should soon see that something is amiss since the opposite leg is the hypotenuse. Let them know that there are other methods of finding the tangent of angles  $90^\circ$  or more. The triangle based definitions of the trigonometric functions that the students are learning in this chapter only apply to angles in the interval  $0^\circ < m < 90^\circ$ .

**The Ratios of an Angle** - The sine, cosine, and tangent are ratios that are associated with a specific angle. Emphasize that there is a pairing between an acute angle measure, and a ratio of side lengths. Sine, cosine, and tangent is best described as functions. If the students' grasp of functions is such that introducing the concept will only confuse matters, the one-to-one correspondence between acute angle and ratio can be taught without getting into the full function definition. When students understand this, they will have an easier time using the notation and understanding that the sine, cosine, and tangent for a specific angle are the same, no matter what right triangle it is being used because all right triangles with that angle will be similar.

**Use Similar Triangles** - Many students have trouble understanding that the sine, cosine, and tangent of a specific angle measure do not depend on the size of the right triangle used to take the ratio. Take some time to go back and explain why this is true using what the students know about similar triangle. It will be a great review and application.

### 2.8. RIGHT TRIANGLE TRIGONOMETRY



Remind the students that if the right triangles have one set of congruent acute angles, then they are similar by the AA Triangle Similarity Postulate. Once the triangles are known to be similar it follows that their sides are proportional. It may be a good activity to have students make right triangles with a particular acute angle measure and compare the ratios of the sides. They should see that no matter how big or small they made their triangle, they get the same ratios as their classmates. You could also refer to the special right triangles to make this connection. Explaining that the names sine, cosine and tangent were given to these ratios and the values were recorded in tables by angle measure may help them understand the idea a little better. You may even want to show them a trig table of values and explain that their calculator is simply looking up a value in a table when they type in the trig function and a particular angle measure.

Here is a Sketchpad activity that may further enhance student understanding:

- Students can construct similar right triangles using dilation from the transformation menu.
- After choosing a specific angle they should measure the corresponding angle in all the triangles. Each of these measurements should be equal.
- The legs of all the right triangles can be measured.
- Then the tangents can be calculated.
- Student should observe that all of ratios are the same.

**Trig Errors are Hard to Catch** - The math of trigonometry is, at this point, not difficult. Not much computation is necessary to choose two numbers and put them in a ratio. What students need to be aware of is how easy it is to make a little mistake and not realize that there is an error. When solving an equation the answer can be substituted back into the original equation to be checked. The sine and cosine for acute angles do not have a wide range. It is extremely easy to mistakenly use the sine instead of the cosine in an application and the difference often is small enough to seem reasonable, but still definitely wrong. Ask the student to focus on accuracy as they work with these new concepts. Remind them to be slow and careful.

**SOHCAHTOA** - This mnemonic device has been around for a while because it helps students keep the ratios straight. Another way to write it that makes it even more clear is:  $S\frac{O}{H} C\frac{A}{H} T\frac{O}{A}$ .

**Something to Consider** - Ask the students to combine their knowledge of side-angle relationships in a triangle with the definition of sine. How does the length of the hypotenuse compare to the lengths of the legs of a right triangle? What does that mean about the types of numbers that can be sine ratios? With leading questions like these students should be able to see that the sine and cosine ratios for an acute angle will always be less than one. This type of analysis will prepare them for future math classes and increase their analytical thinking skills. It will also be a good review of previous material and help them check their work when they first start writing sine and cosine ratios.

**Two-Step Problems** - Having the students write sine, cosine, and tangent ratios as part of two-step problems will help them connect the new material that they have learned to other geometry they know. They will remember it longer, and be better able to see where it can be applied.

Example:  $\triangle ABC$  is a right triangle with the right angle at vertex  $C$ .  $AC = 3$  cm,  $BC = 4$  cm. What is the sine of  $\angle A$ ?

Answer:  $AB = 5$  cm by the Pythagorean theorem, therefore  $\sin A = \frac{4}{5}$ .

Note: The sine of an angle does not have units. The units will cancel out in the ratio.

## Inverse Trigonometric Ratios

**Regular or Arc** - Students will sometimes be confused about when to use the regular trigonometric function and when to use the inverse. They understand the concepts, but do not want to go through the entire thought process each time they must make the decision. I give them this short rule of thumb to help them remember: When looking for a ratio or side length, use regular and when looking for an angle use arc. They can associate “angle” and “arc” in their minds. Use the alliteration.

It may also help to explain that the inverse or “arc” trigonometric function does the reverse of the original. Each of the original three trig functions essentially go to a table, look up an angle measure and find the corresponding ratio. The “arc” functions will look up the ratio in the table and give back the corresponding angle measure. Understanding what it is that the calculator does when they use these functions may help reinforce student understanding.

**Which Trig Ratio** - A common mistake students make when using the inverse trigonometric functions to find angles in right triangles is to use the wrong function. They may use arcsine instead of arccosine for example. There is a process that students can use to reduce the number of these kinds of errors.

- a. First, the students should mark the angle whose measure is to be found. With the angle in question highlighted, it is easier for the students to see the relationship the sides have to that angle. It is fun for the students to use colored pencils, pens, or highlighters.
- b. Next, the students should look at the sides with known side measures and determine their relationship to the angle. They can make notes on the triangle, labeling the hypotenuse, the adjacent leg and the opposite leg. If they are having trouble with this I have them look for the hypotenuse first and always highlight it green, then they can decide between opposite and adjacent for the remaining two sides.
- c. Now, they need to look at the two sides they have chosen, and decide if they need to use sine, cosine, or tangent.

## 2.9 Circles

### Parts of Circles & Tangent Lines

**Circle Vocabulary** - This section has quite a few vocabulary words. Some the students will already know, like radius, and some, like secant, will be new. Encourage the students to make flashcards or a vocabulary list. They should know the word definition and have pictures drawn and labeled. It is also important for students to know the relationships between the words. The radius is half the length of the diameter and the diameter is the longest chord in a circle. Make knowing the vocabulary a specific assignment, otherwise many students will forget to take the time to learn the vocabulary well.

**Circle or Disk** - The phrase “a point on the circle” is commonly used. This will confuse the students that do not realize that the circle is the set of points *exactly* some set distance from the center, and not the points less than that distance. What is happening is that they are confusing the definition of a disk and a circle. Emphasize to the students that a circle is one dimensional; it only contains the points on the edge. Another option is to give them the definition of a disc along with that of a circle, so that they can compare and contrast the two definitions.

**Inscribed or Circumscribed** - An inscribed circle can also be described as a circumscribed polygon. The different ways that these vocabulary words can be used can make learning the relationships complicated. As a guide, tell the students that the object inscribed is on the inside. Starting with that, they can work out the rest. For practice, ask the students to draw different figures that are described in words, like a circumscribed hexagon, or a circle inscribed in an octagon.

**All the Radii of a Circle Are Congruent** - It may seem obvious, but frequently students forget to use the fact that all the radii of a circle are congruent. This follows directly from the definition of a circle. Remind students to use this fact when setting up equations and assigning variables to different radii in the same circle.

**Tangency** - Initially students get very confused by the different tangencies. There is a lot here that they need to digest. Keep reviewing the differences between internally and externally tangent circles and tangent lines that are internal and external so that students have a chance to practice identifying the differences.

**Congruent Tangents** - In this section the Tangent Segment Theorems is proved and applied. Remind student that this is only true for tangents and does not extend to secants. Sometimes student will see a secant enter a circle and think the distance from the exterior point to where the secant intersects the circle is the same as a tangent or another secant from that same point.

**Hidden Tangent Segments** - Sometimes it is difficult for students to recognize tangent segments because they are imbedded in a more complex figure, or the tangent segment is extended in some way. A common situation where this occurs is when there is an inscribed circle. Tell the students to be on the lookout for tangent segments. They should look at segments individually and as part of the whole.

**Using the Pythagorean Theorem to Find Side Measures in Right Triangles** - Using the Pythagorean Theorem to find the measures of sides in a right triangle is a common practice in this section. Students should be on the lookout for right triangles formed by a radius and tangent segment. Later in this chapter they will also find right triangles formed by radii (and diameters) and chords that they bisect. Recognizing these perpendicular segments and the right triangles they form will help students solve problems.

---

## Properties of Arcs

**Naming Major Arcs and Semicircles** - When naming and reading the names of major arcs and semicircles, the three letter system is sometimes confusing for students. When naming an angle with three letters, the first place to look is to the middle letter, the vertex. It is just the opposite for a three letter arc name. First, the students should locate the endpoints of the arc at the ends of the name. For a major arc they have two arcs to choose from. The major arc uses three letters and is the long way around. Any of the other points on the major arc can be used to designate that the long path is being taken. A semicircle divides the circle into two congruent arcs. A third letter is needed to designate which half of the circle is being named.

**Look For Diameters** - When working exercises that call for students to find the measures of arcs by adding and subtracting arc and angle measures in a circle, students often forget that a diameter divides the circle in half, or into two 180 degree arcs. Remind the students to be on the lookout for diameters when finding arc measures.

**Sum is  $360^\circ$**  - Remind students that the entire arc (all the way around the circle) is  $360^\circ$ . This may seem obvious to some students, but others don't pick up on this right away and need reminding.

**Central Angles** - Students may grasp the idea immediately that central angles are equal in measure to the arc they intercept, but they often forget this property as they add additional angle theorems for circles. There are so many different angles that can be formed in circles and this is just the first to be explored. It is imperative that students focus on the fact that central angles have a vertex at the center of the circle (not on the circle or in the circle). Keep saying this every time you talk about a central angle so that students really internalize this definition. If they continually go back to where the vertex is located they will be better able to distinguish between the different types of angles formed by segments in, on and around a circle.

---

## Properties of Chords

**Update the Theorem List** - Students should be keeping a notebook full of all the theorems they have learned in geometry class. The outlines of keywords, definitions and theorems provided at the beginning of each chapter is an excellent basis for this. These theorems are like tools that can be used to work exercises and write proofs. This section has quite a few different theorems about the relationships of chords and angles that need to be included in their notebook. Each entry should have the name of the theorem, the written statement of the theorem, and a picture to illustrate the relationship. Not only will this be good reference material, making the notebook will help the students to remember the material.

**Tips and Suggestions** - There are a few strategies that students should keep in mind when working on the exercises in this section.

- Draw in segments to create right triangles, central angles, and any other useful geometric objects.
- Remember to split the length of the chord in half if only half of it is used in a right triangle. Don't just use the numbers that are given. The theorems must be applied to get the correct number, and multiple steps will usually be necessary.
- Use trigonometry of right triangles to find the angles and segment lengths needed to complete the exercise.
- Don't forget that all radii are congruent. If you have the length of one radius, you have them all, including the ones you add to the figure.
- Employ the Pythagorean theorem and any other tool you have from previous lessons that might be useful.

---

## Inscribed Angles

**Inscribed Angle or Central Angle** - When students spot an arc/angle pair to use in solving a complex circle exercise, the first step is to identify the angle as a central angle, an inscribed angle, or possibly neither. If necessary, they can trace the sides of the angle back from the arc to see where the vertex is located. If the vertex is at the center of the circle, it is a central angle, and the measure of the arc and the angle are equal. If the vertex is on the circle, it is an inscribed angle, and the students must remember to double the angle measure to get the arc measure (or divide the arc measure by 2 to get the angle measure). A good mnemonic device is to think of the arc of an inscribed angle being farther away from the vertex than the arc of a central angle. Therefore the measure of the arc will be larger. If the vertex is at neither the exact center or on the circle, no arc/angle relationship can be determined with only one arc.

**What to Look For** - Students can be overwhelmed by the number of different relationships that need to be used to solve circle exercises. Sometimes they can just get paralyzed and not know where to start. In small groups, or as a class, have them create a list of possible tools that are commonly used in these types of situations.

Does the figure contain?

- A triangle with a sum of  $180^\circ$ .
- A convex quadrilateral with a sum of  $360^\circ$ .
- A right triangle formed with a tangent and radius
- An isosceles triangle formed with two radii
- A diameter creating a semicircle
- Arcs covering the entire circle
- Central or Inscribed angles
- Congruent tangents
- A right angle inscribed in a semicircle
- Perpendicular segments (radius and tangent, radius and chord that is bisected)
- Similar triangle with proportional sides
- Congruent triangles with congruent corresponding parts

**Any New Information is Good** - If students can not immediately see how to find the measure they are after, advise them to find any measure they can. This keeps their mind active and working. Frequently, they will be able to use the new information to find other measures, and will eventually work their way around to the desired answer. This might not be the most efficient method, but the students' technique will improve with practice.

---

## Angles of Chords, Secants, and Tangents

**Where's the Vertex?** - When determining the relationships between angles and arcs in a circle the location of the vertex of the angle is the determining factor. There are four possibilities.

- The vertex of the angle is at the center of the circle, it is a central angle, and the arc and angle have the same measure.
- The vertex of the angle is on the circle. The angle could be made by two chords, an inscribed angle, or by a chord and a tangent. In either situation, the measure of the arc is twice that of the angle.
- The vertex of the angle is inside the circle, but not at the center. In this case two arcs are necessary, and the angle measure is the average of the measures of the arcs cut off by the chords that form the vertical angles.
- The vertex of the angle is outside the circle. Then the two intersected arcs have to be subtracted and the difference divided by two. Note the similarity to an average.

Students often need help organizing information in this way. It is best to do this with them, as a class activity so that in the future they will be able to do it for themselves. After that, lots of practice is advised. This unit is often very difficult for even the strongest math students simply because of the amount of information they must absorb and apply.

**Use the Arcs** - It is typical to have more than one angle intercepting a specific arc. In this case a measure can be moved to an arc and then back out to another angle. Another situation students should look for is when a circle is divided into two arcs. One arc can be represented as  $360^\circ$ -(an expression for the other arc). Students sometimes miss these kinds of moves. It may be beneficial to have students share with the class the different strategies and patterns they see when working on these exercises.

Example 1: Two tangent segments with a common endpoint intercept a circle dividing it into two arcs, one of which is twice as big as the other. What is the measure of the angle formed by the by the two tangents?

Answer:  $60^\circ$ .

Make a sketch to illustrate the problem as shown here.

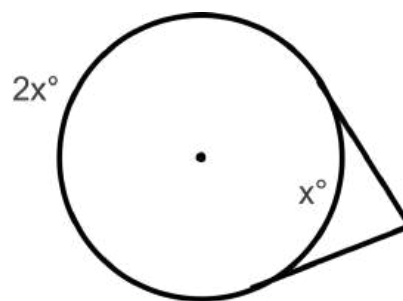

$$x + 2x = 360$$

$$x = 120$$

$$\text{angle measure} = (360 - 120) \div 2 = 120^\circ$$

Example 2: Two intersecting chords intercept congruent arcs. What kind of angles do the chords form?

Answer: Central angles. The chords must intersect at the center of the circle in order to intercept congruent arcs, which makes the angles formed central angles.

## Segments of Chords, Secants, and Tangents

**Chapter Study Sheet** - This chapter contains many relationships for students to remember. It would be helpful for them to summarize all of these relationships on a single sheet of paper to use when studying. Some instructors allow students to use these sheets on the exam in order to encourage students to make the sheets. The value of a study sheet is in its making. Students should know this and make them regardless of whether they can be used on the exams. Sometimes if students know that they will be able to use the study sheet, they will not work to remember all of the relationships, and their ability to learn the material is compromised. It is a hard issue to work around and each instructor needs to deal with it as he or she feels best with their particular classes.

**When to Add** - When writing proportions involving secants, students will have a difficult time remembering to add the two segments together to form the second factor. A careful study of the proof will help them remember this detail. When they see secants, have them picture the similar triangles that could be drawn. Remind them, and give them ample opportunity to practice.

**Go Through the Proportions** - Take the time, if you can, to go through the process of proving these relationships between the lengths of secants, chords and tangents using similar triangles. It is not necessary for students to memorize these proofs, but sometimes they have an easier time remembering the properties if they understand their origins.

**Have Them Subtract** - One way to give students more practice with the lengths of secants in circles is to give them exercises where the entire length of the secant is given, and they have to setup an expression using subtraction to use in the proportion.

Example 1: A secant and a tangent segment have a common exterior endpoint. The secant has a total length of 12 cm and the tangent has length 7 cm. What is the measure of both segments of the secant?

Answer: The secant is composed of two segments with approximate lengths 4.1 cm and 7.9 cm.

Let one segment of the secant be  $x$ , so the other can be represented by  $20 - x$ .

$$7^2 = (12 - x) \times 12$$

$$x \approx 7.9$$

Example 2: Two secant segments have a common endpoint outside of a circle. One has interior and exterior segments of lengths 10 ft and 12 ft respectively and the other has a total measure of 18 ft. What is the measure of the two segments composing the other secant?

Answer: The secant is composed of two segments with lengths  $3\frac{1}{3}$  ft and  $14\frac{2}{3}$  ft.

$$12(10 + 12) = (18 - x) \times 18$$

$$x = 3\frac{1}{3}$$

**Practice, Practice, Practice** - Perhaps the most effective method to get students to internalize the concepts in this chapter is to provide extensive practice. There is just so much information that students are going to have a hard time remembering it all unless they practice it repeatedly. Mixed up the different concepts in a practice assignment so that they get in the habit of switching gears repeatedly and seeing different types of problems on the same page. Too often, students will just assume that all the problems in a particular assignment should be solve the same way and they don't stop to think about how each problem might be different from the previous one. Mixing problems up will help them practice this important skill.

## Extension: Writing and Graphing the Equations of Circles

**Square the Radius** - When working with the equation of a circle, students frequently forget that the radius is squared in the equation, especially when the radius is an irrational number. Explaining the equation of the circle in terms of the Pythagorean theorem will help the students remember and understand how to graph this conic section.

**Remembering the Equation** - Refer back to the definition of a circle- set of all point in the plane equidistant from a given point. This implies that the equation requires this “given” point, or center, and the distance, or radius, of the circle. Show students that the formula is derived by taking a point on the circle,  $(x, y)$ , the center,  $(h, k)$ , and setting the distance between them equal to the radius as shown below.

$$\sqrt{(x - h)^2 + (y - k)^2} = r$$

Now, square both sides to get the equation:  $(x - h)^2 + (y - k)^2 = r^2$

The more students know and understand about the origins of particular equations and properties, the more likely they are to remember them in the future. Going through this process also helps students realize that all these equations are not just “made up”, they have roots in concepts they may already know and understand.

**Completing the Square** - Completing the square to put the equation of a conic section in standard form is a nice little math trick. It exemplifies the kinds of moves mathematicians use to manipulate expressions and equations. Students find it difficult to do especially when fractions are involved and they have trouble retaining the process for more than a few days. Give them many opportunities to practice.



---

## 2.10 Perimeter and Area

---

### Triangles and Parallelograms

**The Importance of Units** - Students will give answers that do not include the proper units, unless it is required by the instructor. When stating an area, square units should be included, and when referring to a length, linear units should be used. Using proper units helps reinforce the basic concepts. With these first simple area problems including the units seems like a small detail, but as the students move to more complex situations combining length, area, and volume, units can be a helpful guide. In physics and chemistry dimensional analysis is an important tool.

**The Power of Labeling** - When doing an exercise where a figure needs to be broken into polynomials with known area formulas, it is important for the student to draw on and label the figure well. Each polygon, so far only parallelograms and triangles, should have their base and height labeled and the individual area should be in the center of each. By solving these exercises in a neat, orderly way student will avoid errors like using the wrong values in the formulas, overlapping polygons, or leaving out some of the total area.

**Subtracting Areas** - Another way of finding the area of a figure that is not a standard polygon is to calculate a larger known area and then subtracting off the areas of polygons that are not included in the target area. This can often result in fewer calculations than adding areas. Different minds work in different ways, and this method might appeal to some students. It is nice to give them as many options as possible so they feel they have the freedom to be creative.

**The Height Must Be Perpendicular to the Base** - Students will frequently take the numbers from a polygon and plug them into the area formula without really thinking about what the numbers represent. In geometry there will frequently be more steps. The students will have to use what they have learned to find the correct base and height and then use those numbers in an area formula. Remind students that they already know how to use a formula; many exercises in this class will require more conceptual work.

**Write Out the Formula** - When using an area formula, it is a good idea to have students first write out the formula they are using, substitute numbers in the next step, and then solve the resulting equation. Writing the formula helps them memorize it and also reduces error when substituting and solving. It is especially important when the area is given and the student is solving for a length measurement in the polygon. Students will be able to do these calculations in their heads for parallelograms, and maybe triangles as well, but it is important to start good habits for the more complex polygons to come.

---

### Trapezoids, Rhombi, and Kites

**It's Arts and Crafts Time** - Student have trouble remembering how to derive the area formulas. At this level it is required that they understand the nature of the formulas and why the formulas work so they can modify and apply them in less straightforward situations. An activity where student follow the explanation by illustrating it with shapes that they cut out and manipulate is much more powerful than just listening and taking notes. It will engage the students, keep their attention, and make them remember the lesson longer. Here are examples of how students can do this for each figure in this section.

**Trapezoid** - This procedure models the description in the text. Actually have students physically cut out the figures and do this will deepen understanding. Afterwards, the pictures in the lesson in the text will have much more

meaning to them as they will have a more concrete understanding of what is going on.

- Have student use the parallel lines on binder paper to draw a trapezoid. They should draw in the height and label it  $h$ . They should also label the two bases  $b_1$  and  $b_2$ .
- Now they can trace and cut out a second congruent trapezoid and label it as they did the first.
- The two trapezoids can be arranged into a parallelogram and glued down to another piece of paper.
- Identify the base and height of the parallelogram in terms of the trapezoid variables. Then substitute these expressions into the area formula of a parallelogram to derive the area formula for a trapezoid.
- Remember that two congruent trapezoids were used in the parallelogram, and the formula should only find the area of one trapezoid.

**Kite** - This particular method is different than the description in the text. You can choose to do this either way, but it helps to improve understanding sometimes to show different methods to achieve the same results. Some students may have an easier time grasping the concept one way or the other.

- Have the students draw a kite. They should start by making perpendicular diagonals, one of which is bisecting the other. Then they can connect the vertices to form a kite.
- Now they can draw in the rectangle around the kite.
- Identify the base and height of the parallelogram in terms of  $d_1$  and  $d_2$ , and then substitute into the parallelogram area formula to derive the kite area formula.
- Now have the students cut off the four triangles that are not part of the kite and arrange them over the congruent triangle in the kite to demonstrate that the area of the kite is half the area of the rectangle.

**Rhombus** - You could allow students to decide which way they would rather do this one or just let them come up with their own method. The more they can do this on their own, the more they have gleaned from this activity.

Also, the area of a rhombus can be found using either the kite or parallelogram area formulas. Use this as an opportunity to review subsets and what they mean in terms of applying formulas and theorems.

---

## Area of Similar Polygons

**Reducing Fractions** - It is helpful in this section to have ratios in reduced form. Once students start square-rooting ratios (in fraction form), however, they may start messing up their reductions. For example, they may start thinking that  $\frac{4}{9}$  reduces to  $\frac{2}{3}$ . Just be aware of this common error and point out the difference to students as needed.

**Adjust the Scale Factor** - It is difficult for students to remember to square and cube the scale factor when writing proportions involving area and volume. Writing and solving a proportion is a skill they know well and have used frequently. Once the process is started, it is hard to remember to add that extra step of checking and adjusting the scale factor in the middle of the process. Here are some ways to reinforce this step in the students' minds.

- Inform students that this material is frequently used on the SAT and other standardized tests in some of the more difficult problems.
- Play with graph paper. Have students draw similar shape on graph paper. They can estimate the area by counting squares, and then compare the ratio of the areas to the ratio of the side lengths. Creating the shapes on graph paper will give the students a good visual impression of the areas.
- Write out steps, or have the students write out the process they will use to tackle these problems. (1) Write a ratio comparing the two polygons. (2) Identify the type of ratio: linear, area, or volume. (3) Adjust the ratio using powers or roots to get the desired ratio. (4) Write and solve a proportion.
- Mix-up the exercises so that students will have to square the ratio in one problem and not in the next. Keep them on the lookout. Make them analyze the situation instead of falling into a habit.

Example 1: The ratio of the lengths of the sides of two squares is 2:3. What is the ratio of their areas?

Answer: 4:9, The ratio of areas is the ratio of the lengths squared.

Example 2: The area of a small triangle is  $15 \text{ cm}^2$ , and it has a height of 5 cm. A larger similar triangle has an area of  $60 \text{ cm}^2$ . What is the corresponding height of the larger triangle?

Answer: 10 cm

The area ratio is 15:60 or 1:4. The length ratio is then the square root of this, or 1:2. Now set up a proportion to solve for the height of the smaller triangle.

$$\frac{1}{2} = \frac{5}{x}$$

Example 3: The ratio of the lengths of two similar rectangles is 4:5. The larger rectangle has a width of 45 cm. What is the width of the smaller rectangle?

Answer: 36 cm.

In this problem, we did not have to adjust the ratio since we are given a ratio of lengths and a length is what we are trying to find. Just set up the proportion and solve.

$$\frac{4}{5} = \frac{x}{45}$$

Example 4: The ratio of the areas of two regular pentagons is 25:64. What is the ratio of their corresponding sides?

Answer: 5:8

This time students have to square root the area ratio to find the ratio of the lengths of the sides.

## Circumference and Arc Length

**Pi is an Irrational Number** - Many students can give the definition of an irrational number. They know that an irrational number has an infinite decimal that has no pattern, but they have not really internalized what this means. Infinity is a difficult concept. A fun way to help the students develop this concept is to have a pi contest. The students can choose to compete by memorizing digits of pi. They can be given points, possible extra credit, for every ten digits or so, and the winner gets a pie of their choice. The students can also research records for memorizing digits of pi. The competition can be done on March 14<sup>th</sup>, pi day. When the contest is introduced, there is always a student who asks "How many points do I get if I memorize it all?" It is a fun way to reinforce the concept of irrational numbers and generate a little excitement in math class.

**There Are Two Values That Describe an Arc** - The measure of an arc describes how curved the arc is, and the length describes the size of the arc. Whenever possible, have the students give both values with units so that they will remember that there are two different numerical descriptions of an arc. Often student will give the measure of an arc when asked to calculate its length.

**Arc Length Fractions** - Fractions are a difficult concept for many students even when they have come as far as geometry. For many of them putting the arc measure over 360 does not obviously give the part of the circumference included in the arc. It is best to start with easy fractions. Use a semi-circle and show how  $\frac{180}{360}$  reduces to  $\frac{1}{2}$ , then a ninety degree arc, and then a 120° arc. After some practice with fractions they can easily visualize, the students will be able to work with any arc measure as a fraction of 360 degrees.

**Exact or Approximate** - When dealing with the circumference of a circle there are often two ways to express the answer. The students can give exact answers, such as  $2\pi$  cm or the decimal approximation 6.28 cm. Explain the strengths and weaknesses of both types of answers. It is hard to visualize  $13\pi$  ft, but that is the only way to accurately express the circumference of a circle with diameter 13 ft. The decimal approximations 41, 40.8, 40.84, etc, can be calculated to any degree of accuracy, are easy to understand in terms of length, but are always slightly wrong. Let the students know if they should give one, the other, or both forms of the answer.

## Areas of Circles and Sectors

**Reinforce** - This section on area of a circle and the area of a sector is analogous to the previous section about circumference of a circle and arc length. This gives students another chance to go back over the arguments and logic to better understand, remember, and apply them. Focus on the same key points and methods in this section, and compare it to the previous section. Mix-up exercises so students will see the similarities and learn each more thoroughly.

**Don't Forget the Units** - Remind students that when they calculate an area the units are squared. When an answer contains the pi symbol, students are more likely to leave off the units. In the answer  $7\pi \text{ cm}^2$ , the  $\pi$  is part of the number and the  $\text{cm}^2$  are units of area.

**Draw a Picture** - When applying geometry to the world around us, it is helpful to draw, label, and work with a picture. Visually organized information is a powerful tool. Remind students to take the time for this step when calculating the areas of the irregular shapes that surround us.

Example 1: What is the area between two concentric circles with radii 5 cm and 12 cm?

(Hint: Don't subtract the radii.)

Answer:  $144\pi - 25\pi = 119\pi \text{ cm}^2$

Example 2: The area of a sector of a circle with radius 6 cm, is  $12\pi \text{ cm}^2$ . What is the measure of the central angle that defines the sector?

Answer:  $12\pi = \frac{x}{360} * \pi * 6^2, x = 120^\circ$ . The central angle measures  $120^\circ$ .

Example 3: A square with side length  $5\sqrt{2} \text{ cm}$  is inscribed in a circle. What is the area of the region between the square and the circle?

Answer: approx.  $28.5 \text{ cm}^2$

First find the diagonal of the square using special right triangles:  $5\sqrt{2} * \sqrt{2} = 5 * 2 = 10$ .

This makes the radius of the circle 5 cm. Now we can find the area of the circle and subtract the area of the square as shown below.

$$5^2 * \pi - (5\sqrt{2})^2$$

$$25\pi - 50 \approx 28.5 \text{ cm}^2$$

## 2.11 Surface Area and Volume

### Exploring Solids

**Polygon or Polyhedron** - A polyhedron is defined using polygons, so in the beginning students will understand the difference. After some time has passed though, students tend to get these similar sounding words confused. Remind them that polygons are two-dimensional and polyhedrons are three-dimensional. The extra letters in polyhedron represents it spreading out into three-dimensions.

**The Limitations of Two Dimensions** - It is difficult for students to see the two-dimensional representations of three-dimensional figures provided in books and on computer screens. A set of geometric solids is easily obtained through teacher supply companies, and are extremely helpful for students as they familiarize themselves with three-dimensional figures. When first counting faces, edges, and vertices most students need to hold the solid in their hands, turn it around, and see how it is put together. After they have some experience with these objects, students will be better able to read the figures drawn in the text to represent three-dimensional objects.

**Assemble Solids** - A valuable exercise for students as they learn about polyhedrons is to make their own. Students can cut out polygons from light cardboard and assemble them into polyhedrons. Patterns are readily available. This hands-on experience with how three-dimensional shapes are put together will help them develop the visualization skills required to count faces, edges, and vertices of polyhedrons described to them.

**Computer Representations** - When shopping on-line it is possible to “grab” and turn merchandise so that they can be seen from different perspectives. The same can be done with polyhedrons. With a little poking around students can find sites that will let them virtually manipulate a three-dimensional shape. This is another possible option to develop the students’ ability to visualize the solids they will be working with for the remainder of this chapter.

**Using the Contrapositive** - If students have already learned about conditional statements, point out to them that Example 4 in this section makes use of the contrapositive. Euler’s formula states that if a solid is a polyhedron, then  $V + F = E + 2$ . The contrapositive is that if  $V + F \neq E + 2$ , then the solid is not a polyhedron. Students need periodic review of important concepts in order to transfer them to their long-term memory. For more review of conditional statements, see the second chapter of this text.

**Each Representation Has Its Use** - Each of the methods for making two-dimensional representations of three-dimensional figures was developed for a specific reason and different representations are most appropriate depending on what aspect of the geometric solid is of interest.

Perspective – used in art, and when one wants to make the representation look realistic

Isometric View – used when finding volume

Orthographic View – used when finding surface area

Cross Section – used when finding volume and the study of conic sections (circles, ellipses, parabolas, and hyperbolas) is based on the cross sections of a cone

Nets – used when finding surface area or assembling solids

Ask the students to think of other uses for these representations.

When students know and fully understand the options, they will be able to choose the best tool for each task they undertake.

**Isometric Dot Paper** - If students are having trouble making isometric drawings, they might benefit from the use

of isometric dot paper. The spacing of the dots allows students to make consistent lengths and angles on their polyhedrons. After some practice with the dot paper, they should be able to make decent drawings on any paper. A good drawing will be helpful when calculating volumes and surface areas.

**Practice** - Most students will need to make quite a few drawings before the result is good enough to be helpful when making calculations. The process of making these representations provides the student with an opportunity to contemplate three-dimensional polyhedrons. The better their concept of these solids, the easier it will be for them to calculate surface areas and volumes in the sections to come.

### **Additional Exercises:**

1. In the next week look around you for polyhedrons. Some example may be a cereal box or a door stop. Make a two-dimensional representation of the object. Choose four objects and use a different method of representation for each.

These can make nice decorations for classroom walls and the assignment makes students look for way to apply what they will learn in this chapter about surface area and volume.

---

## **Surface Area of Prisms and Cylinders**

**The Proper Units** - Students will frequently use volume units when reporting a surface area. Because the number describes a three-dimensional figure, the use of cubic units seems appropriate. This shows a lack of understanding of what exactly it is that they are calculating. Provide students with some familiar applications of surface area like wrapping a present or painting a room, to improve their understanding of the concept. Insist on the use of correct units so the student will have to consider what exactly is being calculated in each exercise.

**Review Area Formulas** - Calculating the surface area and volume of polyhedrons requires the students to find the areas of different polygons. Before starting the new material, take some time to review the area formulas for the polygons that will be used in the lesson. When students are comfortable with the basic area calculations, they can focus their attention on the new skill of working with three-dimensional solids.

**A Prism Does Will Not Always Be Sitting On Its Base** - When identifying prisms, calculating volumes, or using the perimeter method for calculating surface area, it is necessary to locate the bases. Students sometimes have trouble with this when the polyhedron in question is not sitting on its base. Remind students that the mathematical definition of the bases of a prism is two parallel congruent polygons, not the common language definition of a base, which is something an object sits on. Once students think they have identified the bases, they can check that any cross-section taken parallel to the bases is congruent to the bases. Thinking about the cross-sections will also help them understand why the volume formula works later in this chapter.

**Understand the Formula** - Many times students think it is enough to remember and know how to apply a formula. They do not see why it is necessary to understand how and why it works. The benefit of fully understanding what the formula is doing is versatility. Substituting and simplifying works wonderfully for standard cylinders, but what if the surface area of a composite solid needs to be found?

Example 1: Find the surface area of the composite solid shown below.

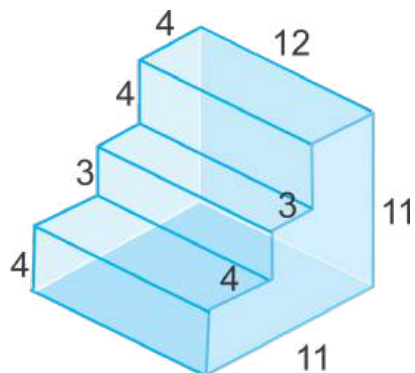

Answer:  $426 u^2$

There are a number of ways to “divide” up this figure into numerous rectangular pieces to find the surface area. One way is to find the areas of the rectangular “steps” and add those to the rectangles formed on the sides of the figure by drawing vertical lines.

$$2(4 \times 12) + 2(3 \times 12) + 2(4 \times 12) + 2\{(4 \times 11) + (3 \times 7) + (4 \times 4)\} = 426 u^2$$

**Make and Take Apart a Cylinder** - Students have a difficult time understanding that the length of the rectangle that composes the lateral area of a cylinder has length equal to the circumference of the circular base. First, review the definition of circumference with the students. A good way to help students visualize this is a soup can label. When the label is removed and placed flat on a table, it is a rectangle. Another way to describe the circumference is to talk about an ant walking around the circle. Next, let them play with some paper cylinders. Have them cut out circular bases, and then fit a rectangle to the circles to make the lateral surface. After some time spent trying to tape the rectangle to the circle, they will understand that the length of the rectangle matches up with the outside of the circle, and therefore, must be the same as the circumference of the circle.

## Surface Area of Pyramids and Cones

**Prism or Pyramid** - Some students have trouble deciding if a solid is a prism or a pyramid. Most try to make the determination by looking for the bases. This is especially tricky if the figure is not sitting on its base. Another method for differentiating between these solids is to look at the lateral faces. If there are a large number of parallelograms, the figure is probably a prism. If there are more triangles, the figure is most likely a pyramid. Once the student has located the lateral faces, then they can make a more detailed inspection of the base or bases.

**Height, Slant Height, or Edge** - A pyramid contains a number of segments with endpoints at the vertex of the pyramid. There is the altitude which is located inside right pyramids, the slant height of the pyramid is the height of the triangular lateral faces, and there are lateral edges, where two lateral faces intersect. Students frequently get these segments confused. To improve their understanding, give them the opportunity to explore with three-dimensional pyramids. Have the students build pyramids out of paper or light cardboard. The slant height of the pyramid should be highlighted along each lateral face in one color, and the edges where the lateral faces come together in another color. A string can be hung from the vertex to represent the altitude of the pyramid. The lengths of all of these segments should be carefully measured and compared. They should make detailed observations before and after the pyramid is assembled. Once the students have gained some familiarity with pyramids and these different segments, it will make intuitive sense to them to use the height when calculating volume, and the slant height for surface area.

Example 1: A square pyramid is placed on top of a cube. The cube has side length 3 cm. The slant height of the triangular lateral faces of the pyramid is 2 cm. What is the surface area of this composite solid?

Answer:  $57 \text{ cm}^2$

Five faces of the cubic base are visible and therefore part of the surface area. Their total area is:  $5 \times 3 \times 3 = 45 \text{ cm}^2$ . The surface area of the pyramid is just the lateral surface area because the base is not visible. This lateral surface area is calculated by multiplying the perimeter of the base by the slant height of the pyramid and then multiplying by one half as shown:  $\frac{1}{2} \times 4 \times 3 \times 2 = 12 \text{ cm}^2$ . Adding these two areas together yields the answer shown above.

Example 2: Calculate the surface area of the composite figure shown below.

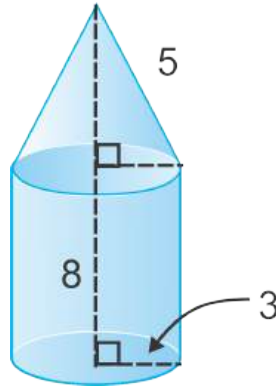

Answer:  $226.19 \text{ u}^2$

The surface area of this figure is the surface area of the cylinder minus the area of the “top” base plus the lateral surface area of the cone. The area of the “top” of the base and the “base” of the cone are not visible and therefore not part of the total surface area of the composite solid. Students are prone to just find the surface areas of the two figures and add them together. This will result in an answer that includes the areas of these two circular bases.

$$\pi 3^2 + 2(3)\pi(8) + \pi(3)(5) \approx 226.19 \text{ u}^2$$

## Volume of Prisms and Cylinders

**The Volume Base** - In the past, when students used formulas, they just needed to identify the correct number to substitute in for each variable. Calculating a volume requires more steps. To find the correct value to substitute into the  $B$  in the formula  $V = Bh$ , usually requires an additional calculation with an area formula. Students will often forget this step, and use the length of the base of the polygon that is the base of the prism for the  $B$ . Emphasize the difference between  $b$ , the linear measurement of the length of a side of a polygon, and  $B$ , the area of the two-dimensional polygon that is the base of the prism. Students can use dimensional analysis to check their work. Volume is measured in cubic units, so three linear measurements, or a linear unit and a squared unit must be fed into the formula.

Example 1: The volume of a 4 in tall coffee cup is approximately  $50 \text{ in}^3$ . What is the radius of the base of the cup?

Answer: The cup has a radius of approximately 2 inches.

Since we know the volume we can use the volume formula with the given height and solve for the radius as shown below:

$$\begin{aligned} 50 &= \pi r^2(4) \\ 3.97887\dots &\approx r^2 \\ r &\approx 2 \end{aligned}$$



Example 2: A prism has a base with area  $15 \text{ cm}^2$  and a height of 10 cm. What is the volume of the prism?

Answer:  $V = 15 \times 10 = 150 \text{ cm}^3$

Example 3: A triangular prism has a height of 7 cm. Its base is an equilateral triangle with side length 4 cm. What is the volume of the prism?

Answer:  $V = Bh = \frac{1}{2}(4)(2\sqrt{3})(7) = 28\sqrt{3} \approx 48.5 \text{ cm}^3$

Given that the sides of the equilateral triangle are 4, then the altitude (height) of the triangle is  $2\sqrt{3}$ . So, the area of the base is  $\frac{1}{2}(4)(2\sqrt{3})$ . Then we can multiply this by the height, 7.

Example 4: The volume of a cube is  $27 \text{ cm}^3$ . What is the cube's surface area?

Answer:  $36 \text{ cm}^2$

This is a two step problem. First, students should find the length of one edge of the cube by finding the cubed root of 27. This is 3. Next, find the area of one square face ( $3^2 = 9$ ) and multiply it by 6 because there are 6 faces.

---

## Volume of Pyramids and Cones

**Don't Forget the  $\frac{1}{3}$**  – The most common mistake students make when calculating the volume of a pyramid is to forget to divide by three. They also might mistakenly divide by three when trying to find the volume of a prism. The first step students should take when beginning a volume calculation, is to make the decision if the solid is a prism or a pyramid. Once they have chosen, they should immediately write down the correct volume formula.

**Prism or Pyramid** - Some students have trouble deciding if a solid is a prism or a pyramid. Most try to make the determination by looking for the bases. This is especially tricky if the figure is not sitting on its base. Another method for differentiating between these solids is to look at the lateral faces. If there are a large number of parallelograms, the figure is probably a prism. If there are more triangles, the figure is most likely a pyramid. Once the student has located the lateral faces, then they can make a more detailed inspection of the base or bases.

**Mix'em Up** - Students have just learned to calculate the surface area and volume of prisms, cylinders, and cones. Most students do quite well when focused on one type of solid. They remember the formulas and how to apply them. It is a bit more difficult when students have to choose between the formulas for all four solids. Take a review day here. Have the students work in small groups during class on a worksheet or group quiz that has a mixture of volume and surface area exercises for these four solids. The extra day will greatly help to solidify the material learned in the last few lessons.

Example 1: A square pyramid is placed on top of a cube. The cube has side length 4 cm. The height of the pyramid is 6 cm. What is the volume of this composite solid?

Answer:  $96 \text{ cm}^3$

The volumes of the cube and square pyramid should be calculated separately and then added together to get the total volume of the composite solid.

Example 2: Calculate the volume of the composite figure shown below.

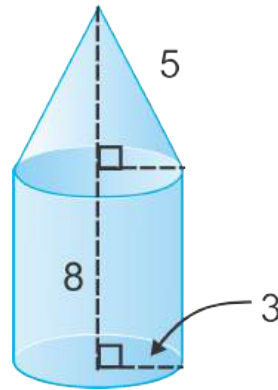

Answer:  $263.89 u^2$

The volume of this composite solid can be calculated by finding the volumes of the cylinder and the cone and adding them together. The Pythagorean theorem (or recognition of a Pythagorean Triple) will be used to determine the height (4) of the cone.

$$\pi 3^2(8) + \frac{1}{3}\pi(3^2)(4) \approx 263.89 u^2$$

## Surface Area and Volume of Spheres

**Expand on Circles** - Students learned about circles earlier in the course. Review and expand on this knowledge as they learn about spheres. Ask the students what they know about circles. Being able to demonstrate their knowledge will build their confidence and activate their minds. Now, modify the definitions that the students have provided to fit the three-dimensional sphere. Students will learn the new material quickly and will remember it because it is now integrated with their knowledge of circles.

**Explore Cross-Sections** - One of the goals of this chapter is to develop the students' ability to think about three-dimensional objects. Most students will need a significant amount of practice before becoming competent at this skill. Take some time and ask the students to think about what the cross-sections of a sphere and a plane will look like. Explore trends. What happens to the cross-section as the plane moves farther away from the center of the circle? A cross-section that passes through the center of the sphere makes the largest possible circle, or the great circle of the sphere.

**Cylinder to Sphere** - It would be a good exercise for students to take the formula for the surface area of a cylinder and derive the formula for the surface area of a sphere. It is just a matter of switching a few variables, but it would be a good exercise for them. During the lesson, ask them to do it in their notes, wait a few minutes and then do it on the board or ask one of them to put their work on the board. It should look something like this:

$$A_{cylinder} = \text{bases} + \text{lateral area}$$

$$A_{cylinder} = 2\pi r^2 + 2\pi rh$$

Now, replace  $h$  with  $r$  to get:

### 2.11. SURFACE AREA AND VOLUME

$$A_{sphere} = 2\pi r^2 + 2\pi r(r)$$

$$A_{sphere} = 2\pi r^2 + 2\pi r^2$$

$$A_{sphere} = 4\pi r^2$$

Point out to students that in the last line the terms could be combined because they both had  $\pi r^2$  and are therefore like terms. The coefficients could have been different, but to combine terms using the distributive property they must have the exact same variable combination. Here the  $\pi$  is being treated as a variable even though it represents a number. This is a more complex application of like terms than students are used to seeing.

**Limits** - Another way to derive the volume of the sphere is to consider a limit. Essentially, the idea is to sum the volume of an infinite number of pyramids. The base of each pyramid is a regular polygon on the surface of the sphere and its height is the sphere's radius.

$$V_{pyramid} = \frac{1}{3}Bh = \frac{1}{3}Br$$

If we let the areas of each of the infinite number of bases be  $B_1, B_2, B_3, \dots$  we get a volume formula for the sphere of:

$$V_{sphere} = \frac{1}{3}B_1r + \frac{1}{3}B_2r + \frac{1}{3}B_3r + \dots$$

Now factor out the  $\frac{1}{3}$  and the  $r$  to get:

$$V_{sphere} = \frac{1}{3}r(B_1 + B_2 + B_3, \dots)$$

Now, we can replace the sum of the infinite base areas with the surface area of the sphere to get:

$$V_{sphere} = \frac{1}{3}r(4\pi r^2)$$

$$V_{sphere} = \frac{4}{3}\pi r^3$$

You can do this in reverse to go from the formula for the volume of a sphere to the surface area of the sphere:

$$V_{sphere} = \frac{4}{3}\pi r^3 = \frac{1}{3}r(4\pi r^2)$$

$$\frac{4}{3}\pi r^3 = \frac{1}{3}r(B_1 + B_2 + B_3, \dots)$$

Now, dividing both sides by  $\frac{1}{3}r$  we get:

$$4\pi r^2 = (B_1 + B_2 + B_3, \dots)$$

Initially, the logic might seem fuzzy to them. The limit is a fundamental concept to all of calculus. It is worthwhile to give it some attention here and some students are more interested in a formula and mathematics in general when they understand where it comes from.

---

## Extension: Exploring Similar Solids

**Surface Area is Squared** - Surface area is a two-dimensional measurement taken of a three-dimensional object. Students are often distracted by the solid and use cubed units when calculating surface area or mistakenly cube the ratio of linear measurements of similar solids when trying to find the ratio of the surface areas. Remind them, and give them many opportunities to practice with exercises where surface area and volume are both used.

**Don't Forget to Adjust the Ratio** - There are three distinct ratios that describe the relationship between similar solids. When the different ratios and their uses are the subject of the lesson, students usually remember to use the correct ratio for the given situation. In a few weeks when it comes to the chapter test or on the final at the end of the year, students will frequently forget that the area ratio is different from the volume ratio and the linear ratio. They enjoy writing proportions and when they recognize that a proportion will be used, they get right to it without analyzing the ratios. One way to remind them is to have them use units when writing proportions. The units on both sides of the equal sign have to match before they can cross-multiply. Give them opportunities to consider the relationship between the different ratios with questions like the one below.

Example 1: If a fully reduced ratio is raised to a power, will the resulting ratio be fully reduced? Explain your reasoning.

Answer: Yes, two numbers make a fully reduced ratio if they have no common factors. Raising a number to a power increases the exponent of each factor already present, but does not introduce new factors. Therefore, the resulting two numbers will still not have any common factors.

These concepts frequently appear on the SAT. It will serve the students well to practice them from time to time to keep the knowledge fresh.

Example 2: The ratio of the surface areas of two cubes is 25:49. What is the ratio of their volumes?

Answer: In order to find the ratio of the volumes, we need to square root the ratio of the areas and then cube the resulting ratio:

$$\begin{aligned}(\sqrt{25})^3 &: (\sqrt{49})^3 \\5^3 &: 7^3 \\125 &: 343\end{aligned}$$

## 2.12 Rigid Transformations

### Exploring Symmetry

**360° Doesn't Count** - When looking for rotational symmetries students will often list 360° rotational symmetry. When a figure is rotated 360° the result is not congruent to the original figure, it is the original figure itself. This does not fit the definition of rotational symmetry. This misconception can cause error when counting the numbers of symmetries a figure has or deciding if a figure has symmetry or not. Another important note here is that sometimes rotational symmetry is referred to as point symmetry. The center “point” of the figure is the center of rotation in a figure with rotational symmetry. Students might be thrown by this new term which might appear on a standardized test if it isn't introduced here.

**Review Quadrilateral Classifications** - Earlier in the course students learned to classify quadrilaterals. Now would be a good time to break out that Venn diagram. Students will have trouble understanding that some parallelograms have line symmetry if they do not remember that squares and rectangles are types of parallelograms. As the course draws to an end, reviewing helps students retain what they have learned past the final. It is possible to redefine the classes of quadrilaterals based on symmetry. This pursuit will make the student use and combine knowledge in different ways making what they have learned more flexible and useful. You may also want to look at the symmetry of regular polygons.

**Applications** - Symmetry has numerous applications both in and outside of mathematics. Knowing some of the uses for symmetry will motivate student, especially those who are not inspired by pure mathematics, to spend their time and energy learning this material.

**Biology** – Most higher level animals have bilateral symmetry, starfish and flowers often have 72° rotational symmetry. Naturally formed nonliving structures like honeycomb and crystals have 60° rotational symmetry. These patterns are fascinating and can be used for classification and study.

**Trigonometry** – Many identities of trigonometry are based on the symmetry of a circle. In the next few years of mathematics the students will see how to simplify extremely complex expressions using these identities.

**Advertising** – Many company logos make use of symmetry. Ask the students to bring in examples of logos with particular types of symmetry and create a class collection. Analyze the trends. Are certain products more appropriately represented by logos that contain a specific type of symmetry? Does the symmetry make the logo more pleasing to the eye or more easily remembered?

**Functions** – A function can be classified as even or odd based on the symmetry of its graph. Even functions have symmetry around the  $y$ -axis, and odd functions have 180° rotational symmetry about the origin. Once a function is classified as even or odd, properties and theorems can be applied to it.

**Draw** - Have students be creative and create their own logos or designs with specific types of symmetry. Using these concepts in many ways will build a deeper understanding and the ability to apply the new knowledge in different situations.

---

## Translations

**Translation or Transformation** - The words translation and transformation look and sound quite similar to students at first. Emphasize their relationship: A translation is just one of the many transformations the students will be learning about in this chapter.

**Image vs Pre-image** - Students often get these two terms mixed up. Help students focus on the prefix, “pre” which means “before”. The pre-image is the image before a transformation is performed.

**Mapping Notation** - An ordered pair is used to represent a location on the coordinate plane, and mapping notation indicates how a point is “moved” to create an image of a point. Give students ample opportunity to practice reading and writing with this notation.

**The Power of Good Notation** - There is a lot going on in these exercises. There are the points that make the preimage, the corresponding points of the image, and the mapping notation used to describe the translation. Good notation is the key to keeping all of this straight. The points of the image should be labeled with capital letters, and the prime marks should be used on the points of the image. In this way it is easy to see where each point has gone. This will be even more important when working with more complex transformations in later sections. Start good habits now.

**Use Graph Paper and a Ruler** - When making graphs of these translations by hand, insist that the students use graph paper and a ruler. If students try to graph on lined paper, the result is frequently messy and inaccurate. It is beneficial for students to see that the pre-image and image are congruent to reinforce the knowledge that a translation is an isometry. It is also important that students take pride in producing quality work. They will learn so much more when they take the time to do an assignment well, instead of just rushing through the work.

**Translations of Sketchpad** - Geometers’ Sketchpad uses vectors to translate figures. The program will display the pre-image, vector, and image at the same time. Students can type in the vector and can also drag points on the screen to see how the image moves when the vector is changed. It is a quick and engaging way to explore the relationships. If the students have access to Sketchpad and there is a little class time available, it is a worthwhile activity. You will need to explain how students can write vector from mapping notation in the program.

---

## Reflections

**Rules for Reflections in the Coordinate Plane** - Students are likely to have a hard time memorizing these rules. Encourage students to just reflect one point at a time until they notice a pattern. When reflecting over the  $y$ -axis, the  $x$  changes sign and when reflecting over the  $x$ -axis, the  $y$  changes sign. Reviewing the quadrants and where  $x$  and  $y$  are positive/negative may also help. They will then see how the signs change as they cross the particular axes.

**Will the Pre-Image and Image Match Up?** - Encourage students to visualize whether or not the image and pre-image will “match up” if they fold over the line of reflection. This check at the end of the process may help students avoid making careless errors.

**Reflections over  $y = x$**  - This particular reflection is very important for students to be able to recognize for future math courses. The inverse of a function is a reflection of the original function over this line. Understanding the connection between the process of creating this reflection (switching  $x$  and  $y$  values) and finding an inverse function later in more advanced algebra courses (students will switch the variables in the equation) will help students gain a deeper understanding of both concepts.

---

## Rotations

**Clockwise vs Counterclockwise Rotations** - Students sometimes have difficulty keeping these two straight. It is also counter-intuitive to them that a counterclockwise angle is considered positive and a clockwise angle is negative. This text uses all positive angles and indicates clockwise vs counterclockwise but if you decide to use Geometer's Sketchpad (or other computer programs) to do some additional activities, you will need to explain this concept to students.

**Rotating in the Coordinate Plane** - There are mapping rules given in the text for the different rotations in the coordinate plane. Sometimes, however, it is helpful to have students attempt to "visualize" these on the coordinate plane. Often students forget the "rules" and cannot complete the assignment or problem on a quiz or test. It may be helpful to do some examples using patty paper. Students can draw a triangle or quadrilateral on the coordinate plane, then trace the figure and the axes onto the patty paper. Now they can rotate the patty paper 90, 180 and 270 degrees using the axes as a reference to see how the figure (and the coordinates of its vertices) change. This technique is particularly beneficial for visual and kinesthetic learners.

---

## Composition of Transformations

**Glide Reflections** - Students sometimes struggle with the concept that order doesn't matter here. It is helpful to have students do a problem such as the example below to experience this.

Example:  $\triangle ABC$  has vertices  $(2, -3)$ ,  $(5, 3)$  and  $(6, 0)$ . Translate this figure 5 units left and reflect it over the line  $y = -2$ . What are the coordinates of the final image? Now try doing the reflection before the translation. What are the coordinates of the final image?

Answer: The coordinates of the resulting images for both orders is  $(-3, -1)$ ,  $(0, -7)$ ,  $(1, -4)$ .

**Reflections over Parallel Lines** - Students may initially struggle with the relationship between this double reflection and the resulting equivalent translation. Have students practice this on the coordinate plane where distances between the vertices of the pre-image and image can be easily calculated to verify the relationship.

**Reflections over both Axes** - Patty paper can be used again here to help students see that this double reflection is actually a rotation of  $180^\circ$  about the origin. Students can also compare the rules for reflections to the rules for rotations to see that the combination of the two reflections results in the rule for the rotation.

---

## Extension: Tessellating Polygons

**Review Interior Angles Measures for Polygons** - Earlier in the course students learned how to calculate the sum of the measures of interior angles of a convex polygon, and how to divide by the number of angles to find the measures of the interior angle of regular polygons. Now would be a good time to review this lesson. The students will need this knowledge to see which regular polygons will tessellate and the final is fast approaching.

**Move Them Around** - When learning about regular and semi-regular tessellation it is helpful for students to have a set of regular triangles, squares, pentagons, hexagons, and octagons that they can slide around and fit together. These shapes can be bought from a mathematics education supply company or made with paper. Exploring the relationships in this way gives the students a fuller understanding of the concepts.

**Use On-Line Resources** - A quick search on tessellations will produce many beautiful, artistic examples like the work of M. C. Escher and cultural examples like Moorish tiling. This bit of research will inspire students and show them how applicable this knowledge is to many areas.

**Tessellation Project** - A good long-term project is to have the students create their own tessellations. This is an artistic endeavor that will appeal to students that typically struggle with mathematics, and the tessellations make nice decorations for the classroom.



