

## Unit 8 :

# ROBOTICS

## INTRODUCTION

Robots are devices that are programmed to move parts, or to do work with a tool. Robotics is a multidisciplinary engineering field dedicated to the development of autonomous devices, including manipulators and mobile vehicles.

### The Origins of Robots

Year 1250

Bishop Albertus Magnus holds banquet at which guests were served by metal attendants. Upon seeing this, Saint Thomas Aquinas smashed the attendants to bits and called the bishop a sorcerer.

Year 1640

Descartes builds a female automaton which he calls “Ma fille Francine.” She accompanied Descartes on a voyage and was thrown overboard by the captain, who thought she was the work of Satan.

Year 1738

Jacques de Vaucanson builds a mechanical duck quack, bathe, drink water, eat grain, digest it and void it. Whereabouts of the duck are unknown today.

Year 1805

Doll, made by Maillardet, that wrote in either French or English and could draw landscapes

Year 1923

Karel Capek coins the term *robot* in his play *Rossum's Universal Robots (R.U.R)*. *Robot* comes from the Czech word *robota*, which means “servitude, forced labor.”

Year 1940

Sparko, the Westinghouse dog, was developed which used both mechanical and electrical components.

Year 1950's to 1960's

Computer technology advances and control machinery is developed. Questions Arise: Is the computer an immobile robot? Industrial Robots created. Robotic Industries Association states that an "industrial robot is a re-programmable, multifunctional manipulator designed to move materials, parts, tools, or specialized devices through variable programmed motions to perform a variety of tasks"

Year 1956

Researchers aim to combine "perceptual and problem-solving capabilities," using computers, cameras, and touch sensors. The idea is to study the types of intelligent actions these robots are capable of. A new discipline is born: A.I.

Year 1960

Shakey is made at Stanford Research Institute International. It contained a television camera, range finder, on-board logic, bump sensors, camera control unit, and an antenna for a radio link. Shakey was controlled by a computer in a different room.

The first industrial robot: UNIMATE Year 1954

The first programmable robot is designed by George Devol, who coins the term Universal Automation. He later shortens this to Unimation, which becomes the name of the first robot company (1962).

Year 1978

The Puma (Programmable Universal Machine for Assembly) robot is developed by Unimation with a General Motors design support

Year 1980s

The robot industry enters a phase of rapid growth. Many institutions introduce programs and courses in robotics. Robotics courses are spread across mechanical engineering, electrical engineering, and computer science departments.

Year 1995-present

Emerging applications in small robotics and mobile robots drive a second growth of start-up companies and research

2003

NASA's Mars Exploration Rovers will launch toward Mars in search of answers about the history of water on Mars

## Categories in Robot Studies

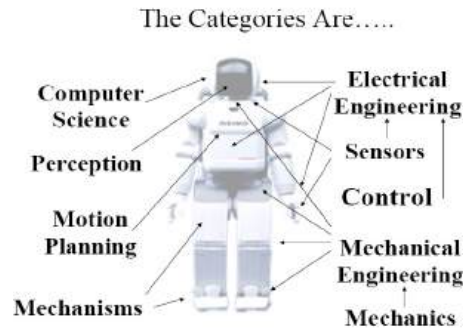

## Definition

An industrial robot is a general purpose, programmable machine possessing certain anthropomorphic characteristics. The most typical anthropomorphic or human like, characteristics of a robot is its arm. This arm, together with the robots capacity to be programmed, make it ideally suited to a variety of production tasks, including machine loading, spot welding, spray painting and assembly. The robot can be programmed to perform sequence of mechanical motions, and it can repeat that motion sequence over the over until programmed to perform some other job.

An industrial robot is a general purpose programmable machine that possesses certain anthropomorphic features

- The most apparent anthropomorphic feature of an industrial robot is its mechanical arm, or manipulator
- Robots can perform a variety of tasks such as loading and unloading machine tools, spot welding automobile bodies, and spray painting
- Robots are typically used as substitutes for human workers in these tasks

**An industrial robot is a programmable, multi-functional manipulator designed to move materials, parts, tools, or special devices through variable programmed motions for the performance of a variety of tasks.**

An industrial robot consists of a mechanical manipulator and a controller to move it and perform other related functions

- The mechanical manipulator consists of joints and links to position and orient the end of the manipulator relative to its base
- The controller operates the joints in a coordinated fashion to execute a programmed work cycle
- A robot joint is similar to a human body joint It provides relative movement between two parts of the body
- Typical industrial robots have five or six joints, Manipulator joints: classified as linear or rotating

### How are robots used?

- Industrial robots do tasks that are hazardous or menial.
- Exploratory robots explore environments that are inhospitable to humans such as space, military targets or areas of search and rescue operations.
- Assistive robots help handicapped individuals by assisting with daily tasks including wheelchair navigation and feeding.

### ROBOT ANATOMY

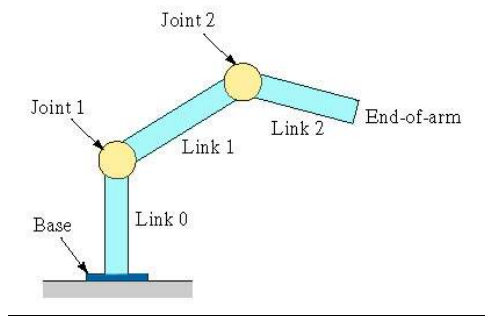

Translational motion

Linear joint (type L)

Orthogonal joint (type O)

Rotary motion

Rotational joint (type R)

Twisting joint (type T)

Revolving joint (type V)

### Types of joints

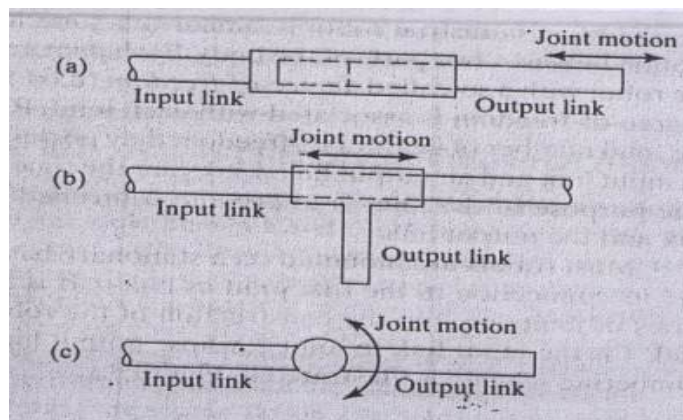

(a) Linear joint (type L joint) , (b) orthogonal joint (type O joint ) (c) Rotational joint (type R joint )

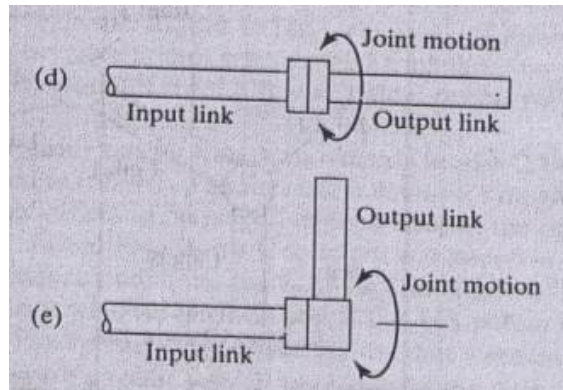

(d) Twisting joint ( type T joint) (e) revolving joint (type V joint)

### Robot Physical Configuration

Industrial robots come in a variety of shapes and sizes. They are capable of various arm manipulations and they possess different motion systems.

Classification based on Physical configurations

Four basic configurations are identified with most of the commercially available industrial robots

**1. Cartesian configuration:** A robot which is constructed around this configuration consists of three orthogonal slides, as shown in fig. the three slides are parallel to the x, y, and z axes of the Cartesian coordinate system. By appropriate movements of these slides, the robot is capable of moving its arm at any point within its three dimensional rectangularly spaced work space.

**2. Cylindrical configuration:** in this configuration, the robot body is a vertical column that swivels about a vertical axis. The arm consists of several orthogonal slides which allow the arm to be moved up or down and in and out with respect to the body. This is illustrated schematically in figure.

**3. Polar configuration:** this configuration also goes by the name “spherical coordinate” because the workspace within which it can move its arm is a partial sphere as shown in figure. The robot has a rotary base and a pivot that can be used to raise and lower a telescoping arm.

**4. Jointed-arm configuration:** is combination of cylindrical and articulated configurations. This is similar in appearance to the human arm, as shown in fig. the arm consists of several

straight members connected by joints which are analogous to the human shoulder, elbow, and wrist. The robot arm is mounted to a base which can be rotated to provide the robot with the capacity to work within a quasi-spherical space.

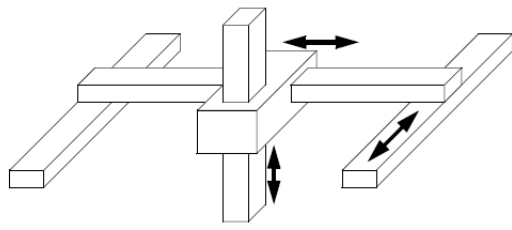

CARTESIAN/RECTILINEAR/GANTRY

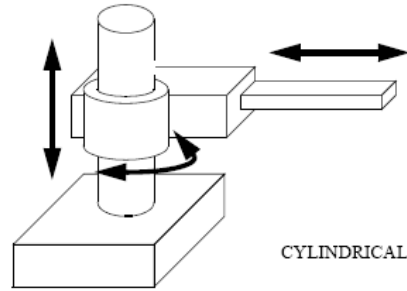

CYLINDRICAL

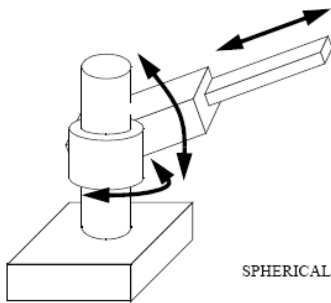

SPHERICAL

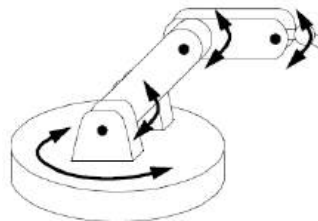

ARTICULATED/REVOLUTE/  
JOINTED SPHERICAL

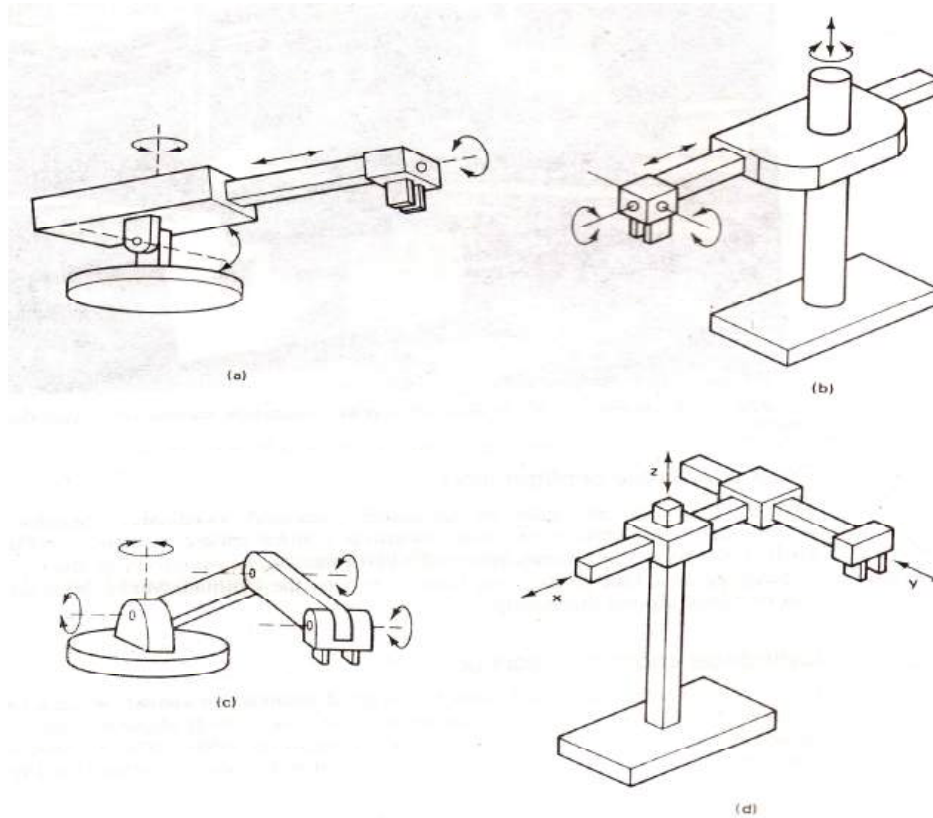

## **Basic Robot Motions**

Whatever the configuration, the purpose of the robot is to perform a useful task. To accomplish the task, an end effector, or hand, is attached to the end of the robot's arm. It is the end effector which adapts the general purpose robot to a particular task. To do the task, the robot arm must be capable of moving the end effectors through a sequence of motions and positions.

There are six basic motions or degrees of freedom, which provide the robot with the capability to move the end effectors through the required sequences of motions. These six degrees of freedom are intended to emulate the versatility of movement possessed by the human arm. Not all robots are equipped with the ability to move in all six degrees. The six basic motions consist of three arm and body motions and three wrist motions.

### **Arm and body motions**

1. Vertical traverse: Up and down motion of the arm, caused by pivoting the entire arm about a horizontal axis or moving the arm along a vertical slide.
2. Radial traverse: extension and retraction of the arm (in and out movement)
3. Rotational traverse: rotation about the vertical axis (right or left swivel of the robot arm)

Wrist Motion

- Wrist swivel: Rotation of the wrist
- Wrist bend: Up or down movement of the wrist, this also involves rotation movement.
- Wrist yaw: Right or left swivel of the wrist.

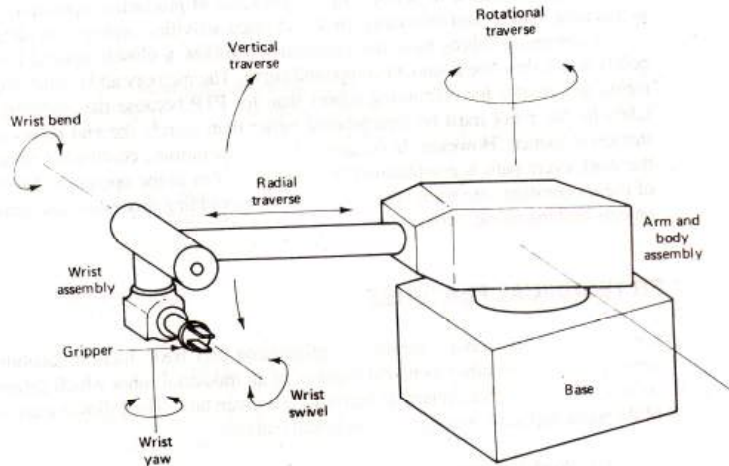

**Advantages and disadvantages of 5 types of robots**

Configurations	Advantages	Disadvantages
Cartesian coordinates	3 linear axes, easy to visualize, rigid structure, easy programming	Can only reach front of itself, require long room space.
Cylindrical coordinates	2 linear axes + 1 rotating can reach all around itself, reach and height axes rigid, rotational axis easy to seal	Can't reach above itself, base rotation axis as less rigid, linear axis is hard to seal.
SCARA coordinates	1 linear + 2 rotational axes is rigid, large work space area for floor space	2 ways to reach point, difficult to program offline, highly complex arm
Spherical coordinates	1 linear + 2 rotational axes, long horizontal reach	Can't reach around obstacles, short vertical length
Revolve coordinates	3 rotational axes can reach above or below obstacles.	Difficult to program off-line, most complex manipulator



### Motion system

1. **Point-to-point (PTP) control robot:** is capable of moving from one point to another point. The locations are recorded in the control memory. PTP robots do not control the path to get from one point to the next point. Common applications include component insertion, spot welding, hole drilling, machine loading and unloading, and crude assembly operations.
2. **Continuous-path (CP) control robot:** with CP control, the robot can stop at any specified point along the controlled path. All the points along the path must be stored explicitly in the robot's control memory. Typical applications include spray painting, finishing, gluing, and arc welding operations.
3. **Controlled-path robot:** the control equipment can generate paths of different geometry such as straight lines, circles, and interpolated curves with a high degree of accuracy. All controlled-path robots have a servo capability to correct their path.

### Technical Features Of An Industrial Robot

The technical features of an industrial robot determine its efficiency and effectiveness at performing a given task. The following are some of the most important among these technical features.

**Degree of Freedom (D.O.F)** - Each joint on the robot introduces a degree of freedom. Each dof can be a slider, rotary, or other type of actuator. Robots typically have 5 or 6 degrees of freedom. 3 of the degrees of freedom allow positioning in 3D space, while the other 2 or 3 are used for orientation of the end effector. 6 degrees of freedom are enough to allow the robot to reach all positions and orientations in 3D space. 5 D.O.F requires a restriction to 2D space, or else it limits orientations. 5 D.O.F robots are commonly used for handling tools such as arc welders.

**Work Volume/Workspace** - The robot tends to have a fixed and limited geometry. The work envelope is the boundary of positions in space that the robot can reach. For a Cartesian robot (like an overhead crane) the workspace might be a square, for more sophisticated robots the workspace might be a shape that looks like a 'clump of intersecting bubbles'.

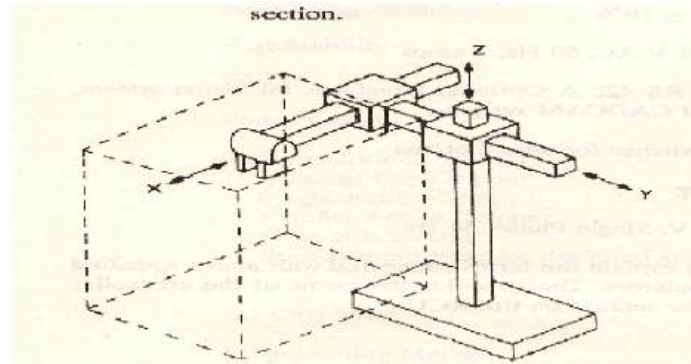

Fig. 10.3 Cartesian Workspace configuration

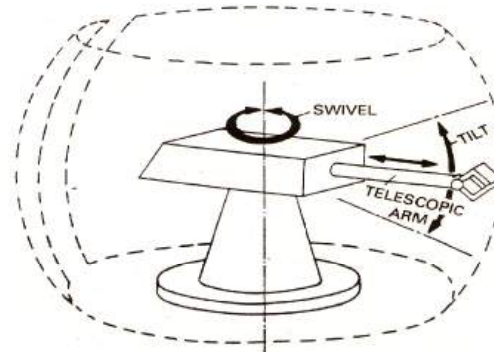
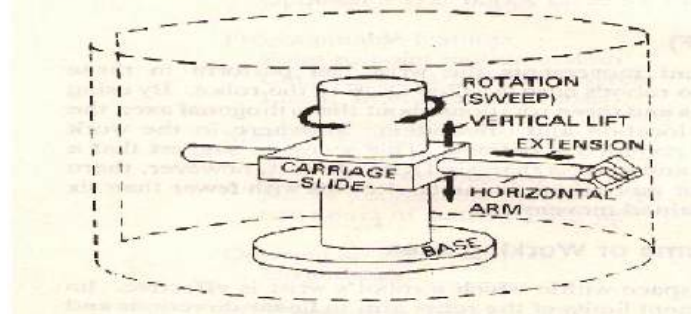
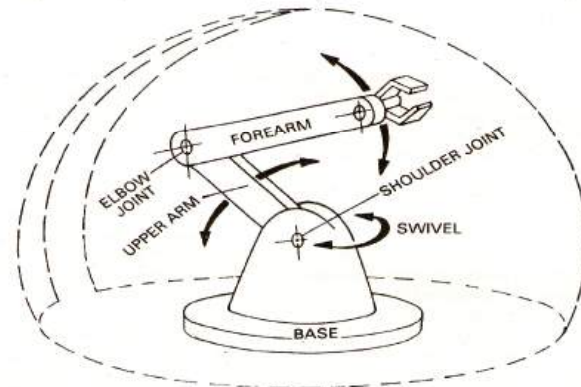

Fig. 10.5 Spherical Workspace Configuration



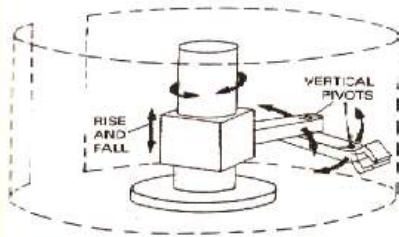

Fig. 10.7 Articulated or Jointed arm Configuration with Vertical pivots

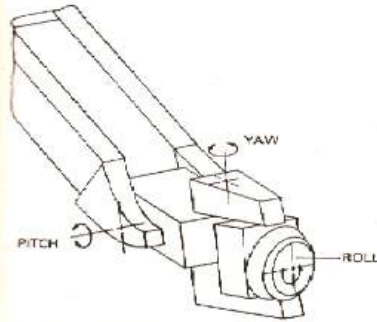

Fig. 10.8 Wrist Axes

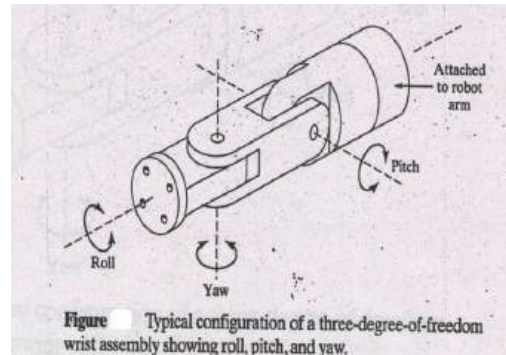

Figure Typical configuration of a three-degree-of-freedom wrist assembly showing roll, pitch, and yaw.

### Precision Movement

The precision with which the robot can move the end of its wrist is a critical consideration in most applications. In robotics, precision of movement is a complex issue, and we will describe it as consisting of three attributes:

1. Control resolution
2. Accuracy
3. Repeatability

**Control Resolution** - This is the smallest change that can be measured by the feedback sensors, or caused by the actuators, whichever is larger. If a rotary joint has an encoder that measures every 0.01 degree of rotation, and a direct drive servo motor is used to drive the joint, with a resolution of 0.5 degrees, then the control resolution is about 0.5 degrees (the worst case can be  $0.5+0.01$ ).

**Accuracy** - This is determined by the resolution of the workspace. If the robot is commanded to travel to a point in space, it will often be off by some amount, the maximum distance should be considered the accuracy.

**Repeatability** - The robot mechanism will have some natural variance in it. This means that when the robot is repeatedly instructed to return to the same point, it will not always stop at the same position.

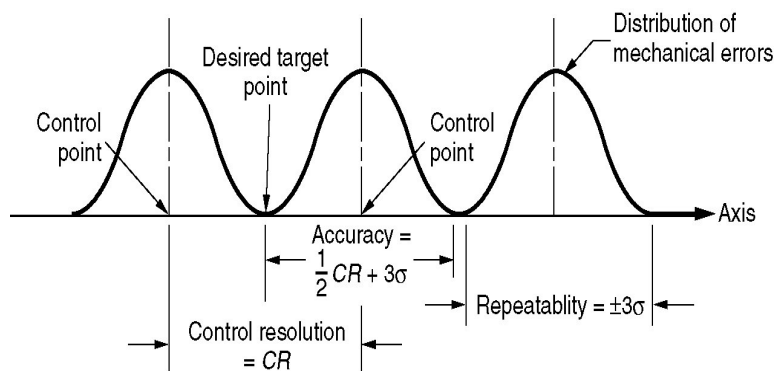
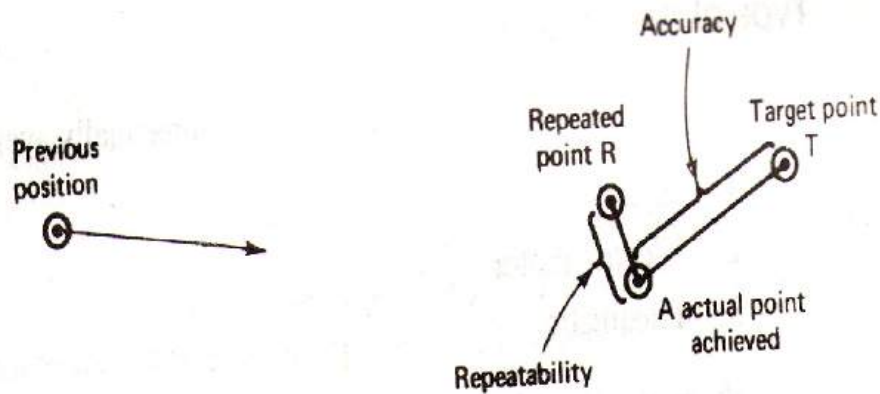
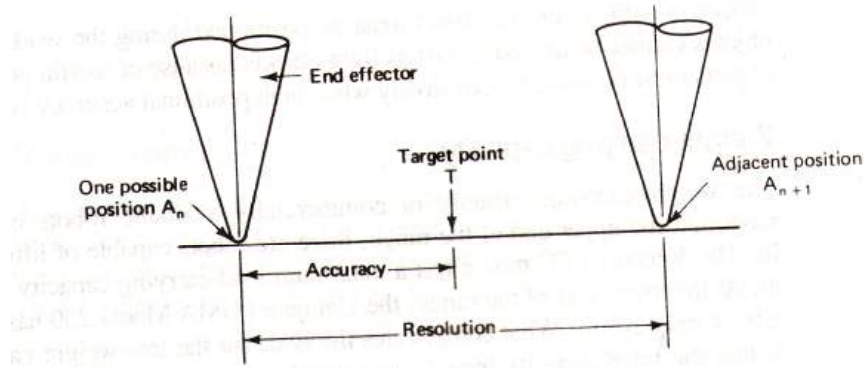

A portion of a linear positioning system axis, with showing control resolution, accuracy, and repeatability

**Speed** - refers either to the maximum velocity that is achievable by the TCP, or by individual joints. This number is not accurate in most robots, and will vary over the workspace as the geometry of the robot changes.

**Weight Carrying Capacity (Payload)** - The payload indicates the maximum mass the robot can lift before either failure of the robots, or dramatic loss of accuracy. It is possible to exceed the maximum payload, and still have the robot operate, but this is not advised. When

the robot is accelerating fast, the payload should be less than the maximum mass. This is affected by the ability to firmly grip the part, as well as the robot structure, and the actuators. The end of arm tooling should be considered part of the payload.

### Types Of Drive Systems

There are three basic drive system used in commercially available robots:

**1. Hydraulic drive:** gives a robot great speed and strength. These systems can be designed to actuate linear or rotational joints. The main disadvantage of a hydraulic system is that it occupies floor space in addition to that required by the robot.

**2. Electric drive:** compared with a hydraulic system, an electric system provides a robot with less speed and strength. Accordingly, electric drive systems are adopted for smaller robots. However, robots supported by electric drive systems are more accurate, exhibit better repeatability, and are cleaner to use.

**3. Pneumatic drive:** are generally used for smaller robots. These robots, with fewer degrees of freedom, carry out simple pick-and-place material handling operations.

## PROGRAMMING THE ROBOT

There are various methods which robots can be programmed to perform a given work cycle. We divide this programming method into four categories.

1. Manual method
2. Walkthrough method
3. Lead through method
4. Off-line programming

### **Manual method:**

This method is not really programming in the conventional sense of the world. It is more like setting up a machine rather than programming. It is the procedure used for the simpler robots and involves setting mechanical stops, cams, switches or relays in the robots control unit. For these low technology robots used for short work cycles (e.g., pick and place operations), the manual programming method is adequate.

### **Walkthrough method:**

In this method the programmer manually moves the robots arm and hand through the motion sequence of the work cycle. Each movement is recorded into memory for subsequent playback during production. The speed with which the movements are performed can usually be controlled independently so that the programmer does not have to worry about the cycle time during the walk through. The main concern is getting the position sequence correct. The walk through method would be appropriate for spray painting and arc welding.

### **Lead through method:**

The lead through method makes use of a teach pendant to power drive the robot through its motion sequence. The teach pendant is usually a small hand held device with switches and dials to control the robots physical movements. Each motion is recorded into memory for future playback during work cycle. The lead through method is very popular among robot programming methods because of its ease and convenience.

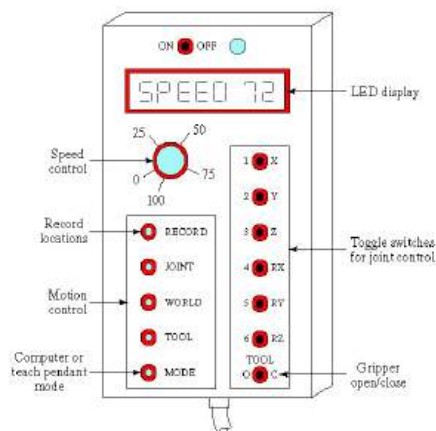

### **On-Line/Lead -Through programming**

Advantage:

- Easy
- No special programming skills or training

Disadvantages:

- not practical for large or heavy robots
- High accuracy and straight-line movements are difficult to achieve, as are any other kind of geometrically defined trajectory, such as circular arcs, etc.
- difficult to *edit out* unwanted operator moves
- difficult to incorporate external sensor data
- Synchronization with other machines or equipment in the work cell is difficult
- A large amount of memory is required

### **Off- line programming:**

This method involves the preparation of the robot program off-line, in a manner similar to NC part programming. Off-line robot programming is typically accomplished on a computer terminal. After the program has been prepared, it is entered in to the robot memory for use during the work cycle. The advantage of off-line robot programming is that the production time of the robot is not lost to delay in teaching the robot a new task. Programming off-line can be done while the robot is still in production on the preceding job. This means higher utilization of the robot and the equipment with which it operates.

Another benefit associated with off-line programming is the prospect of integrating the robot into the factory CAD/CAM data base and information system.

### **Robot Programming Languages**

Non computer controlled robots do not require programming language. They are programmed by the walkthrough or lead through methods while the simpler robots are programmed by manual methods. With the introduction of computer control for robots came the opportunity and the need to develop a computer oriented robot programming language.

### **The VAL™ Language**

- The VAL language was developed for PUMA robot
- VAL stands for Victors Assembly Language



- It is basically off-line language in which program defining the motion sequence is can be developed off-line but various point location used in the work cycle are defined by lead through.
- VAL statements are divided into two categories a) Monitoring command b) Programming instructions.
- Monitor command are set of administrative instructions that direct the operation of the robot system. Some of the functions of Monitor commands are
  - Preparing the system for the user to write programs for PUMA
  - Defining points in space
  - Commanding the PUMA to execute a program
  - Listing program on the CRT
- Examples for monitor commands are: EDIT, EXECUTE, SPEED, HERE etc.
- Program instructions are a set of statements used to write robot programs. One statement usually corresponds to one movement of the robots arm or wrist.
- Example for program instructions are Move to point, move to a point in a straight line motion, open gripper, close gripper. (MOVE, MOVES, APPRO, APPROX, DEPART, OPENI, CLOSEI, AND EXIT)

### **The MCL Language**

- MCL stands for Machine Control Language developed by Douglas.
- The language is based on the APT and NC language. Designed control complete manufacturing cell.
- MCL is enhancement of APT which possesses additional options and features needed to do off-line programming of robotic work cell.
- Additional vocabulary words were developed to provide the supplementary capabilities intended to be covered by the MCL. These capability include Vision, Inspection and Control of signals
- MCL also permits the user to define MACROS like statement that would be convenient to use for specialized applications.
- MCL program is needed to compile to produce CLFILE.
- Some commands of MCL programming languages are DEVICE, SEND, RECEIV, WORKPT, ABORT, TASK, REGION, LOCATE etc.

### **Textual Statements**

Language statements taken from commercially available robot languages

1 The basic motion statement is:

#### **MOVE P1**

Commands the robot to move from its current position to a position and orientation defined by the variable name P1. The point p1 must be defined.



The most convenient method way to define P1 is to use either powered lead through or manual leads through to place the robot at the desired point and record that point into the memory.

**HERE P1**

**OR**

**LEARN P1**

Are used in the lead through procedure to indicate the variable name for the point

What is recorded into the robot's control memory is the set of joint positions or coordinates used by the controller to define the point.

For ex, (236,157,63,0,0,0)

The first values give joint positions of the body and arm and the last three values(0,0,0) define the wrist joint positions.

**MOVES P1**

Denotes a move that is to be made using straight line interpolation. The suffix 's' designates a straight line motion.

**DMOVE (4,125)**

Suppose the robot is presently at a point defined by joint coordinates(236,157,63,0,0,0) and it is desired to move joint 4 from 0 to 125. The above statement can be used to accomplish this move. DMOVE represents a delta move.

Approach and depart statements are useful in material handling operations.

**APPROACH P1, 40 MM**

**MOVE P1**

(Command to actuate the gripper)

**DEPART 40 MM**

The destination is point p1 but the approach command moves the gripper to a safe distance(40mm) above the point.

Move statement permits the gripper to be moved directly to the part for grasping.

A path in a robot program is a series of points connected together in a single move. A path is given a variable name

DEFINE PATH123=PATH(P1,P2,P3)

A move statement is used to drive the robot through the path.

**MOVE PATH123**

**SPEED 75** the manipulator should operate at 75% of the initially commanded velocity. The initial speed is given in a command that precedes the execution of the robot program.

For example,

SPEED 0.5 MPS

## EXECUTE PROGRAM1

Indicates that the program named PROGRAM1 is to be executed by the robot at a speed of 0.5m/sec.

### Interlock And Sensor Statements

The two basic interlock commands used for industrial robots are WAIT and SIGNAL. The wait command is used to implement an input interlock.

For example,

#### **WAIT 20,ON**

Would cause program execution to stop at this statement until the input signal coming into the robot controller at port 20 was in “ON” condition.this might be used in a situation where the robot needed to wait for the completion of an automatic machine cycle in a loading and unloading application.

The SIGNAL statement is used to implement an output interlock. This is used to communicate to some external piece of equipment.

For example,

#### **SIGNAL 20, ON**

Would switch on the signal at output port 20, perhaps to actuate the start of of an automatic machine cycle.

The above interlock commands represent situations where the execution of the statement appears.

There are other situations where it is desirable for an external device to be continuously monitored for any change that might occur in the device.

For example,in safety monitoring where a sensor is setup

to detect the presence of humans who might wander into the robot’s work volume.the sensor reacts to the presence of humans by signaling the robot controller.

#### **REACT 25, SAFESTOP**

This command would be written to continuously monitor input port 25 for any changes in the incoming signal. If and when a change in the signal occurs, regular program execution is interrupted and the control is transferred to a subroutine called SAFESTOP.This subroutine would stop the robot from further motion and/or cause some other safety action to be taken.

Commands for controlling the end-effectors

Although end effectors are attached to to the wrist of the manipulator,they are very much like external devices. Special command are written for controlling the end effector. Basic commands are

**OPEN** (fully open)

and

**CLOSE** (fully close)

For grippers with force sensors that can be regulated through the robot controller, a command such as ,

**CLOSE 2.0 N**

Controls the closing of the gripper until a 20.N force is encountered by the grippers.

A similar command would be used to close the gripper to a given opening width is, **CLOSE 25 MM**

A special set of statements is often required to control the operation of tool type end effectors .(such as spot welding guns, arc welding tools, spray painting guns and powered spindles ).

### End Effectors

In the terminology of robotics, end effectors can be defined as a device which is attached to the robots wrist to perform a specific task. The task might be work part handling, spot welding, spray painting, or any of a great variety of other functions. The possibilities are limited only by the imagination and ingenuity of the application engineers who design robot systems. The end effectors are the special purpose tooling which enables the robot to perform a particular job. It is usually custom engineered for that job, either by the company that owns the robot or company that sold the robots. Most robot manufacturer has engineered groups which design and fabricate end effectors or provide advice to their customers on end effectors design.

For purpose organization, we will divide the various types of end effectors into two categories: grippers and tools.

1. **Grippers:** are generally used to grasp and hold an object and place it at a desired location. Grippers can be classified as

Mechanical grippers

Vacuum or suction cups

Magnetic grippers

Adhesive grippers

Hooks,

Scoops, and so forth.

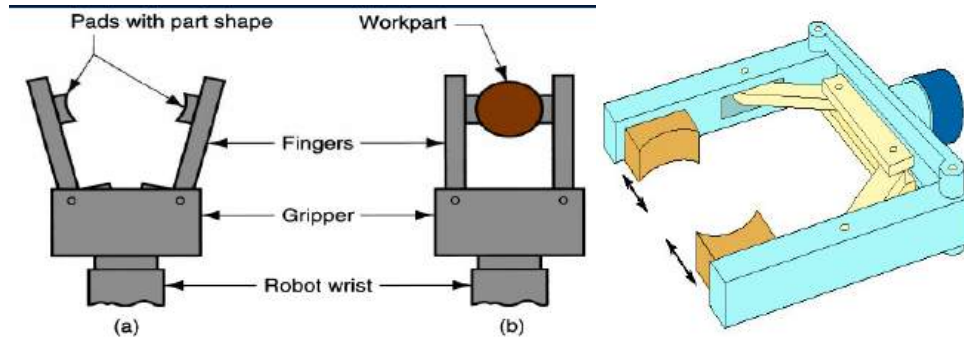

2. **Tools:** a robot is required to manipulate a tool to perform an operation on a work part. Here the tool acts as end-effectors. Spot-welding tools, arc-welding tools, spray-painting nozzles, and rotating spindles for drilling and grinding are typical examples of tools used as end-effectors.

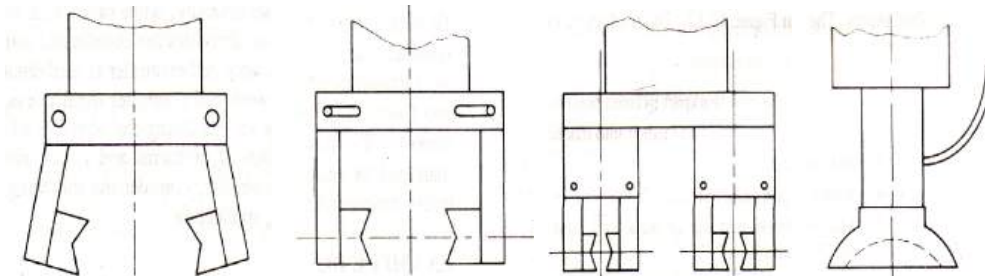

### Work Cell Control And Interlocks

Work cell control: industrial robots usually work with other things: processing equipment, work parts, conveyors, tools and perhaps human operators. A means must be provided for coordinating all of the activities which are going on within the robot workstations. Some of the activities occur sequentially, while others take place simultaneously to make certain that the various activities are coordinated and occur in the proper sequence, a device called the work cell controller is used. The work cell controller usually resides within the robots and has overall responsibility for regulating the activities of the work cell components.

Functions of work cell controller

1. Controlling the sequence of activities in the work cycles
2. Controlling simultaneous activities
3. Making decisions to proceed based on incoming signals
4. Making logical decisions
5. Performing computations
6. Dealing with exceptional events
7. Performing irregular cycles, such as periodically changing tools

### Interlocks

An interlock is the feature of work cell control which prevents the work cycle sequence from continuing until a certain conditions or set of conditions has been satisfied. In a robotic work cell, there are two types: outgoing and incoming. The outer going interlock is a signal sent from the workstation controller to some external machine or device that will cause it to operate or not to operate for example this would be used to prevent a machine from initiating its process until it was commanded to process by the work cell controller, an incoming interlock is a signal from some external machine or device to the work controller which determines whether or not the programmed work cycle sequence will proceed. For example, this would be used to prevent the work cycle program from continuing until the machine signaled that it had completed its processing of the work piece.

The use of interlocks provides an important benefit in the control of the work cycle because it prevents actions from happening when they should not, and it causes actions occur when they should. Interlocks are needed to help coordinate the activities of the various independent components in the work cell and to help avert damage of one component by another. In the planning of interlocks in the robotic work cell, the application engineer must consider both the normal sequences of the activities that will occur during the work cycle, and the potential malfunction that might occur. Then these normal activities are linked together by means of limit switches, pressure switches, photo electric devices, and other system components. Malfunction that can be anticipated are prevented by means of similar devices.

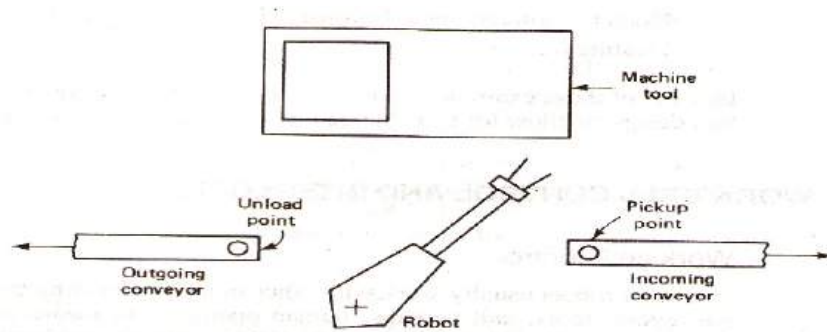

## **ROBOTIC SENSORS**

For certain robot application, the type of workstation control using interlocks is not adequate the robot must take on more human like senses and capabilities in order to perform the task in a satisfactory way these senses and capability includes vision and hand eye coordination, touch, hearing accordingly we will divided the types of sensors used in robotics into the following three categories.

1. Vision sensors
2. Tactile and proximity sensors
3. Voice sensors

### **Vision sensors**

This is one of the areas that is receiving a lot of attention in robotics research computerized visions systems will be an important technology in future automated factories. Robot vision is made possible by means of video camera a sufficient light source and a computer programmed to process image data. The camera is mounted either on the robot or in a fixed position above the robot so that its field of vision includes the robots work volume. The computer software enables the vision system to sense the presence of an object and its position and orientation. Vision capability would enable the robot to carry out the following kinds of operations.

Retrieve parts which are randomly oriented on a conveyor

Recognize particular parts which are intermixed with other objects

Perform assembly operations which require alignment

### **Tactile and proximity sensor**

Tactile sensors provide the robot with the capability to respond to contact forces between itself and other objects within its work volume. Tactile sensors can be divided into two types:

1. Touch sensors
2. Stress sensors

Touch sensors are used simply to indicate whether contact has been made with an object. A simple micro switch can serve the purpose of a touch sensor. Stress sensors are used to measure the magnitude of the contact force. Strain gauge devices are typically employed in force measuring sensors.

Potential use of robots with tactile sensing capabilities would be in assembly and inspection operations. In assembly, the robot could perform delicate part alignment and joining operations. In inspection, touch sensing would be used in gauging operations and dimensional measuring activities. Proximity sensors are used to sense when one object is close to another

object. On a robot, the proximity sensors would be located on or near the end effectors. This sensing capability can be engineered by means of optical proximity devices, eddy-current proximity detectors, magnetic field sensors, or other devices.

In robotics, proximity sensors might be used to indicate the presence or absence of a work part or other object. They could also be helpful in preventing injury to the robots human coworkers in the factory.

### **Voice sensors**

Another area of robotics research is voice sensing or voice programming. Voice programming can be defined as the oral communication of commands to the robot or other machine. The robot controller is equipped with a speech recognition system which analyzes the voice input and compares it with a set of stored word patterns when a match is found between the input and the stored vocabulary word the robot performs some actions which corresponds to the word. Voice sensors could be useful in robot programming to speed up the programming procedure just as it does in NC programming. It would also be beneficial in especially in hazardous working environments for performing unique operations such as maintenance and repair work. The robot could be placed in hazardous environment and remotely commanded to perform the repair chores by means of step by step instructions.

### **Sensors – summary**

- Sensors provide a way of simulating “aliveness”
- Sensors give robots environmental awareness
- Sensors provide of means of human protection
- Sensors help robot preserve itself
- Sensors enable goal seeking
- Sensors enable closed-loop interaction
- Sensors make robots interesting
- Sensors can make programming “challenging”

## **ROBOT APPLICATIONS**

Need to replace human labor by robots:

- Work environment hazardous for human beings
- Repetitive tasks
- Boring and unpleasant tasks
- Multi shift operations
- Infrequent changeovers
- Performing at a steady pace
- Operating for long hours without rest
- Responding in automated operations
- Minimizing variation

Industrial Robot Applications can be divided into:

Material-handling applications:

- Involve the movement of material or parts from one location to another.
- It includes part placement, palletizing and/or depalletizing, machine loading and unloading.

Processing Operations:

- Requires the robot to manipulate a special process tool as the end effectors.
- The application include spot welding, arc welding, riveting, spray painting, machining, metal cutting, deburring, polishing.

Assembly Applications:

- Involve part-handling manipulations of a special tools and other automatic tasks and operations.

Inspection Operations:

- Require the robot to position a work part to an inspection device.
- Involve the robot to manipulate a device or sensor to perform the inspection.

### **Material Handling Applications**

This category includes the following:

- Part Placement
- Palletizing and/or depalletizing



- Machine loading and/or unloading
- Stacking and insertion operations

#### Part Placement:

- The basic operation in this category is the relatively simple pick-and-place operation.
- This application needs a low-technology robot of the cylindrical coordinate type.
- Only two, three, or four joints are required for most of the applications.
- Pneumatically powered robots are often utilized.

#### Palletizing and/or Depalletizing

- The applications require robot to stack parts one on top of the other, that is to palletize them, or to unstack parts by removing from the top one by one, that is depalletize them.
- Example: process of taking parts from the assembly line and stacking them on a pallet or vice versa.

#### Machine loading and/or unloading:

- Robot transfers parts into and/or from a production machine.
- There are three possible cases:
  - Machine loading in which the robot loads parts into a production machine, but the parts are unloaded by some other means.

Example: a press working operation, where the robot feeds sheet blanks into the press, but the finished parts drop out of the press by gravity.
  - Machine loading in which the raw materials are fed into the machine without robot assistance. The robot unloads the part from the machine assisted by vision or no vision.

Example: bin picking, die casting, and plastic moulding.
  - Machine loading and unloading that involves both loading and unloading of the work parts by the robot. The robot loads a raw work part into the process and unloads a finished part.

Example: Machine operation difficulties

- Difference in cycle time between the robot and the production machine. The cycle time of the machine may be relatively long compared to the robot's cycle time.

Stacking and insertion operation:

- In the stacking process the robot places flat parts on top of each other, where the vertical location of the drop-off position is continuously changing with cycle time.
- In the insertion process robot inserts parts into the compartments of a divided carton.

The robot must have following features to facilitate material handling:

- The manipulator must be able to lift the parts safely.
- The robot must have the reach needed.
- The robot must have cylindrical coordinate type.
- The robot's controller must have a large enough memory to store all the programmed points so that the robot can move from one location to another.
- The robot must have the speed necessary for meeting the transfer cycle of the operation.

### **Processing operations:**

- Robot performs a processing procedure on the part.
- The robot is equipped with some type of process tooling as its end effector.
- Manipulates the tooling relative to the working part during the cycle.
- Industrial robot applications in the processing operations include:
  - Spot welding
  - Continuous arc welding
  - Spray painting
  - Metal cutting and deburring operations
  - Various machining operations like drilling, grinding, laser and water jet cutting, and riveting.
  - Rotating and spindle operations
  - Adhesives and sealant dispensing

**Assembly operations:**

- The applications involve both material-handling and the manipulation of a tool.
- They typically include components to build the product and to perform material handling operations.
- Are traditionally labor-intensive activities in industry and are highly repetitive and boring. Hence are logical candidates for robotic applications.
- These are classified as:
  - Batch assembly: As many as one million products might be assembled.
  - The assembly operation has long production runs.
  - Low-volume: In this a sample run of ten thousand or less products might be made.
  - The assembly robot cell should be a modular cell.
  - One of the well suited areas for robotics assembly is the insertion of odd electronic components.

**Inspection operation:**

- Some inspection operation requires parts to be manipulated, and other applications require that an inspection tool be manipulated.
- Inspection work requires high precision and patience, and human judgment is often needed to determine whether a product is within quality specifications or not.
- Inspection tasks that are performed by industrial robots can usually be divided into the following three techniques:
  - By using a feeler gauge or a linear displacement transducer known as a linear variable differential transformer (LVDT), the part being measured will come in physical contact with the instrument or by means of air pressure, which will cause it to ride above the surface being measured.
  - By utilizing robotic vision, matrix video cameras are used to obtain an image of the area of interest, which is digitized and compared to a similar image with specified tolerance.
  - By involving the use of optics and light, usually a laser or infrared source is used to illustrate the area of interest.
- The robot may be in active or passive role.
  - In active role robot is responsible for determining whether the part is good or bad.
  - In the passive role the robot feeds a gauging station with the part. While the gauging station is determining whether the part meets the specification, the robot waits for the process to finish.

### **Advantages of Robots**

- Robotics and automation can, in many situation, increase productivity, safety, efficiency, quality, and consistency of Products
- Robots can work in hazardous environments
- Robots need no environmental comfort
- Robots work continuously without any humanity needs and illnesses
- Robots have repeatable precision at all times
- Robots can be much more accurate than humans, they may have milli or micro inch accuracy.
- Robots and their sensors can have capabilities beyond that of humans.
- Robots can process multiple stimuli or tasks simultaneously, humans can only one.
- Robots replace human workers who can create economic problems.

### **Disadvantages of Robots**

- Robots lack capability to respond in emergencies, this can cause:
  - Inappropriate and wrong responses
  - A lack of decision-making power
  - A loss of power
  - Damage to the robot and other devices
  - Human injuries
- Robots may have limited capabilities in
  - Degrees of Freedom
  - Dexterity
  - Sensors
  - Vision systems
  - Real-time Response
- Robots are costly, due to
  - Initial cost of equipment
  - Installation Costs
  - Need for peripherals
  - Need for training
  - Need for Programming

### **Summary of Robot Applications**

General characteristics of industrial work situations that promote the use of industrial robots

1. Hazardous work environment for humans
2. Repetitive work cycle
3. Difficult handling task for humans
4. Multi shift operations
5. Infrequent changeovers
6. Part position and orientation are established in the work cell