

SYNTHESIS 06/40 GAS CONVEYOR OVEN 1SV4407B



SPECIFICATIONS

Voltage	Single Phase, 230 VAC, 50/60 Hz
	Current at 220-240 V~, 2A
Max Power	450 Watts
Flame Control	Electronic without pilot
Gas Absorption	32.4 MJ/h NAT Gas, 30 MJ/h ULPG Gas
Injector Diameter (NAT)	(G20 - 20 mbar) - 3 x 1.55 mm
Injector Diameter (ULPG)	(G30 - 28...30 mbar) - 3 x 0.90 mm
Min pressure (NAT)	(G20 - 20 mbar) - 0.3Kpa
Max pressure (NAT)	(G20 - 20 mbar) - 1 kPa
Min pressure (ULPG)	(G30 - 28...30 mbar) - 0.8kpa
Max pressure (ULPG)	(G30 - 28...30 mbar) - 2.,75 kPa
Consumption (NAT)	(G20 - 20 mbar) - 0,952 m3/h
Consumption (ULPG)	(G30 - 28...30 mbar) - 0.071 Kg/h
Gas Pipe	1/2"
Weight	115 kg
Conveyor Width	16" (400mm)
Conveyor Length	1070mm
Chamber Length	580mm
Chamber Height	95mm
Cable Length	2m
Plug Supplied	Yes, 10 amps
Noise level	< 70 decibels
Max Humidity	95% without condensation
Ambient Temperature	0 - 40°C
Thermostat	320°C
Time Range	1:45 minutes - 30 minutes (or complete halt)
Warranty	4 Year Warranty (2 yr Labour 4 yr Parts)



Main Features

- Made entirely from stainless steel
- Easy access for thorough cleaning
- Cooling system for contact parts
- Omnidirectional wheels with breaks (With stand Option)
- Conveyor belt with variable speed down to a complete halt
- 90 mm high cooking chamber
- Fine tuning of the ventilation flow
- Jets of hot air completely wrap the product as it moves along the wire mesh conveyer giving an evenly cooked result time after time
- All Synthesis ovens are stackable so you can step up your productivity to meet peak demand
- Management of 6 cooking programs: for each program you can set the cooking time, and temperature
- Economy function keeps the oven at a lower temperature if it doesn't need to be operated at full working temperature
- Timer for programmed start, digital clock and self diagnostics

DIMENSIONS

External Width	1300mm	Internal Width	580mm
External Depth	1030mm	Internal Depth	400mm
External Height	440mm	Internal Height	95mm



Phone: 1800 183 818 Email: support@thegoodlady.com.au
Website: www.thegoodlady.com.au

SYNTHESIS 06/40 SINGLE STACK CONVEYOR



FRONT

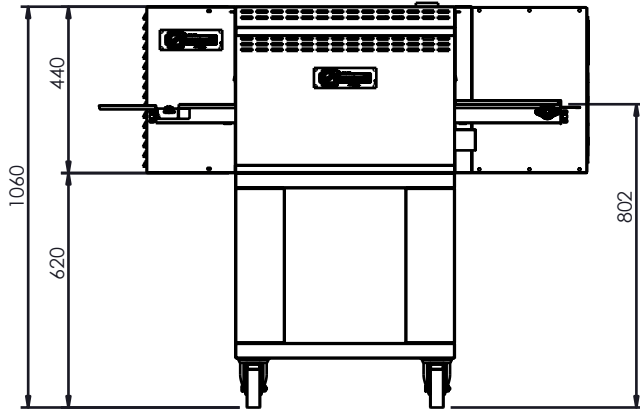

SIDE

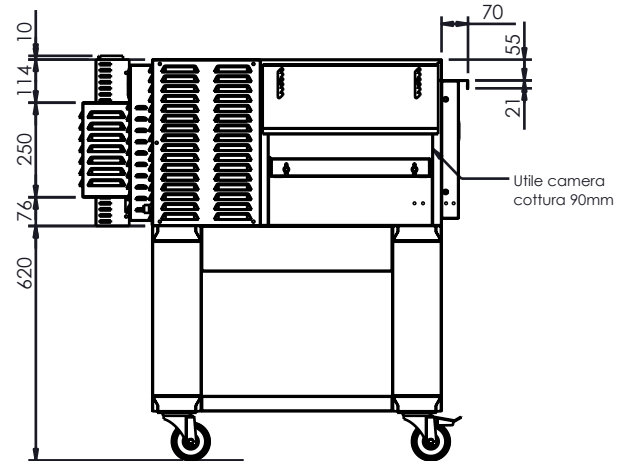

Num. articolo	Quantità	Descrizione	Potenza gas	Potenza el
11		0SV2A14		
21		1SV4407	9Kw(7770Kcal/h)	0.44Kw

TOP

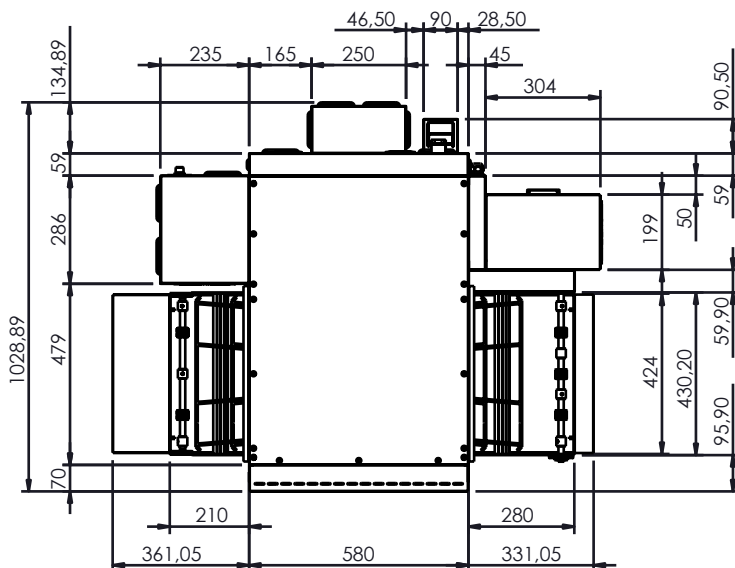

REAR

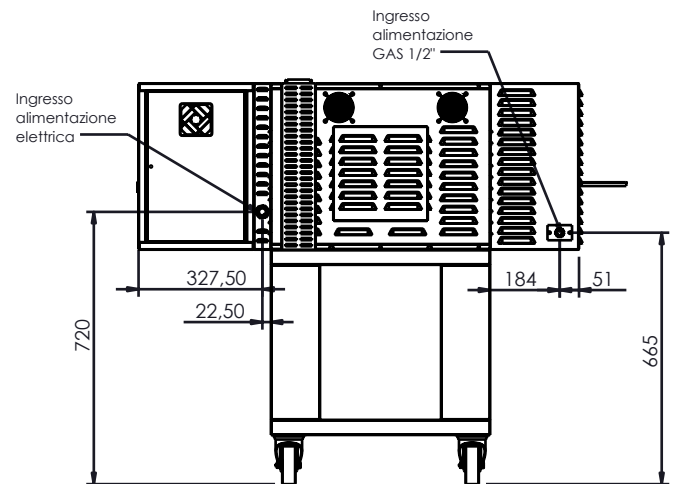

We reserve the right to alter specifications without notice.



THE GOOD LADY

Phone: 1800 183 818 Email: support@thegoodlady.com.au
Website: www.thegoodlady.com.au

SYNTHESIS 06/40 DOUBLE STACK CONVEYOR



FRONT

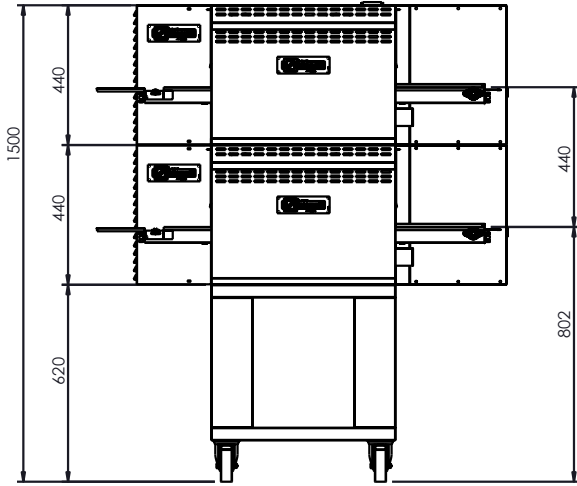

Num. articolo	Quantità	Descrizione	Potenza gas	Potenza el
11		0SV2A14		
22		1SV4407	18Kw (15540 Kcal/h)	0.88Kw

SIDE

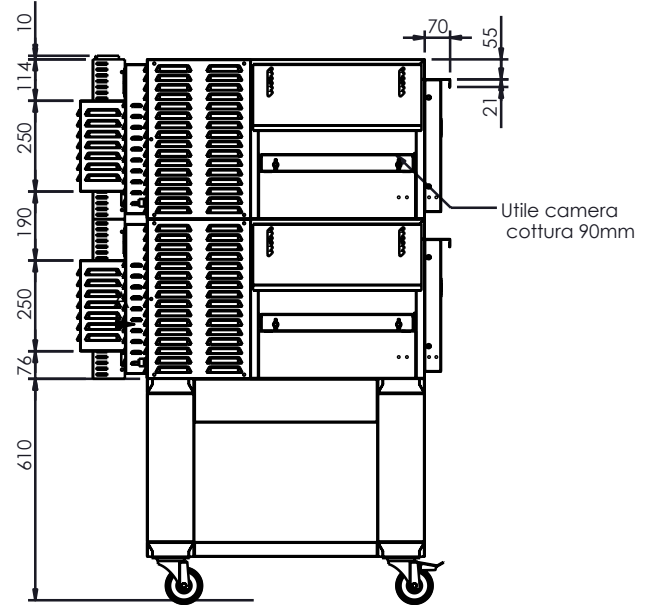

TOP

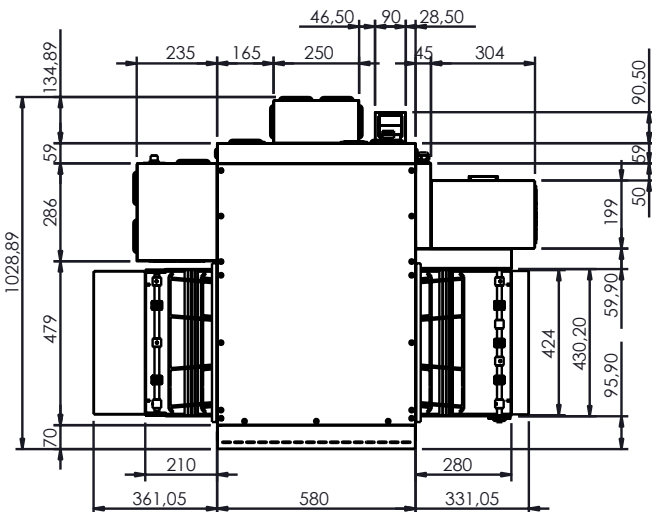

REAR

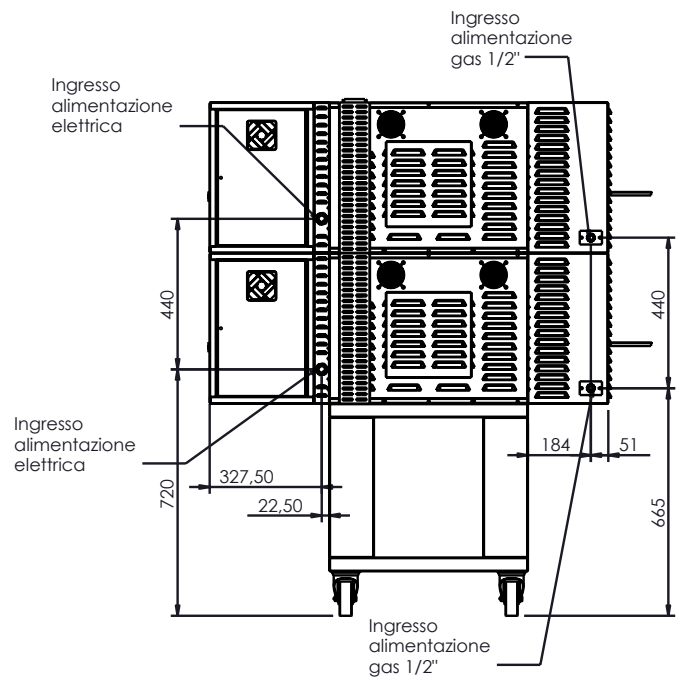

We reserve the right to alter specifications without notice.



THE
GOOD
LADY

Phone: 1800 183 818 Email: support@thegoodlady.com.au
Website: www.thegoodlady.com.au

SYNTHESIS 06/40 TRIPLE STACK CONVEYOR



FRONT

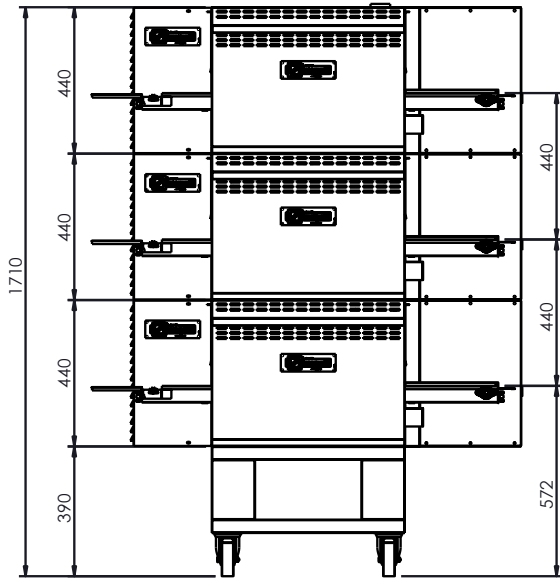

Num. articolo	Quantità	Descrizione	Potenza gas	Potenza el
11		0SV2A15		23947.90
23		1SV4407	27Kw (23310Kcal/h)	1.32Kw

SIDE

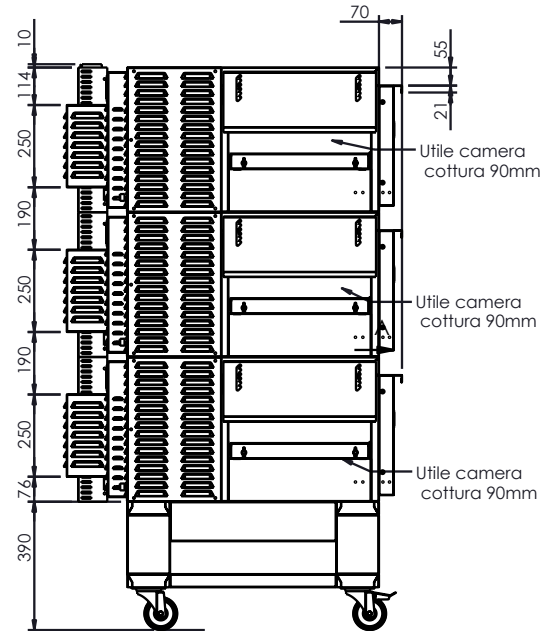

TOP

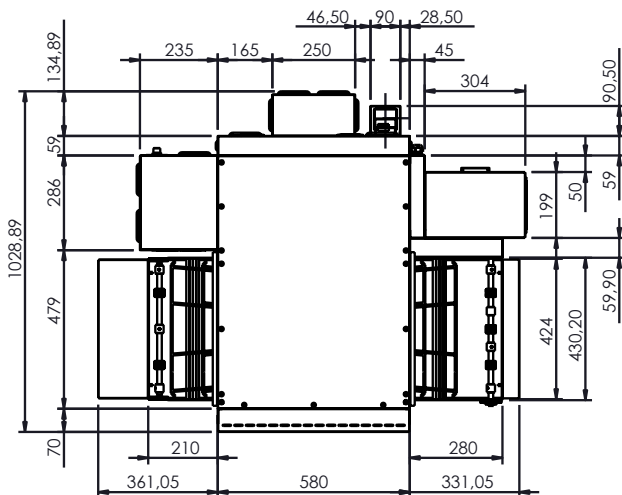

REAR

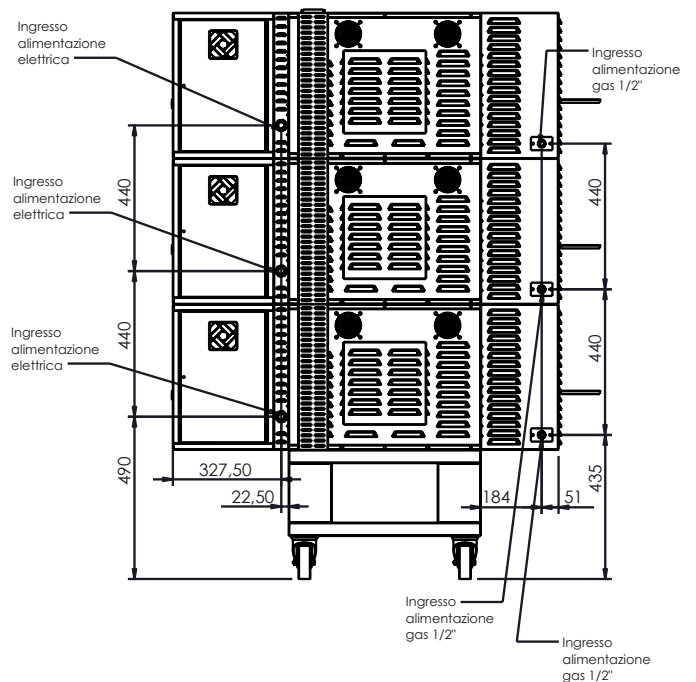

We reserve the right to alter specifications without notice.



THE
GOOD
LADY

Phone: 1800 183 818 Email: support@thegoodlady.com.au
Website: www.thegoodlady.com.au