

# ROTOR WIND 5EF

36 TRAY ELECTRIC ROTATING BAKING OVEN (WIDE VERSION)

5RW0700



## Main Features

The Air Flow crosses a Group of armor plated Heating Elements laid out in order to ensure an Optimal Performance of the Oven.

- 36 Tray Capacity (400 x 600)
- High Production
- Steam Exhaust Fan
- Front surface and Baking Chamber Completely in Stainless steel.
- Extractable trolley for which makes it easier to use
- Electromechanical Control Panel which enables the control of:
  - (a) Temperature
  - (b) Ventilation
  - (c) Rack Rotation
  - (d) Supply of Steam
  - (e) Baking Timers
  - (f) shut down/start ups
  - (f) Lighting control
- New steam generator embraced in the ventilation area ensures steam is spread inside the chamber in a very homogenous way through the ventilation system.



## SPECIFICATIONS

|               |   |
|---------------|---|
| Voltage       | 400 V 3 Phase                                       |
| Power         | 47 kw   |
| Weight        | 1380 kg   |
| Plug Supplied | No  |
| Capacity      | 15/18 Trays x (800 x 600) or<br>30/36 x (400 x 600) |
| Thermostat    | 300°C   |
| Baking Volume | 8.6 m <sup>2</sup>                                  |
| Warranty      | 4 Year Warranty (2 yr Labour 4 yr Parts)            |

## ACCESORIES

|                               |                                     |
|-------------------------------|-------------------------------------|
| Trolleys 15 Tray (600 x 800)  | Computerized Panel                  |
| Trolleys 30 Trays (400 x 600) | Variable Speed System for Exhaust   |
| Trolleys 18 Tray (600 x 800)  | Turn Table Rotation Option as       |
| Trolleys 36 Trays (400 x 600) | opposed to Standard Hooking system. |

## DIMENTIONS

|                 |        |
|-----------------|--------|
| External Width  | 1840mm |
| External Depth  | 1850mm |
| External Height | 2700mm |



Phone: 1800 183 818 Email: support@thegoodlady.com.au  
Website: www.thegoodlady.com.au

# FRONT

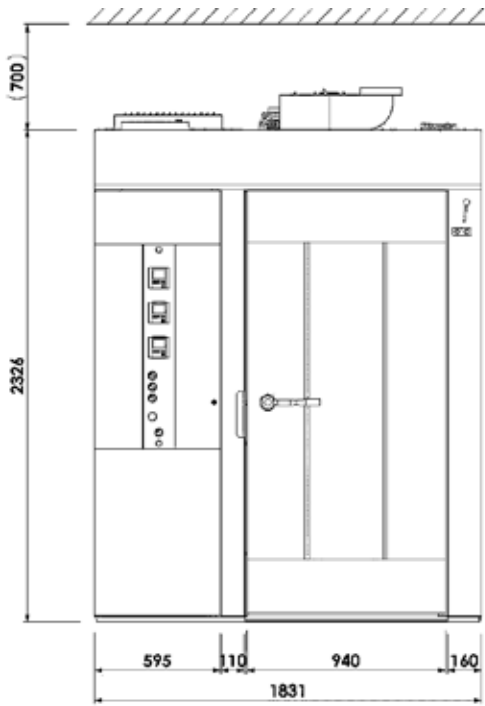

# SIDE

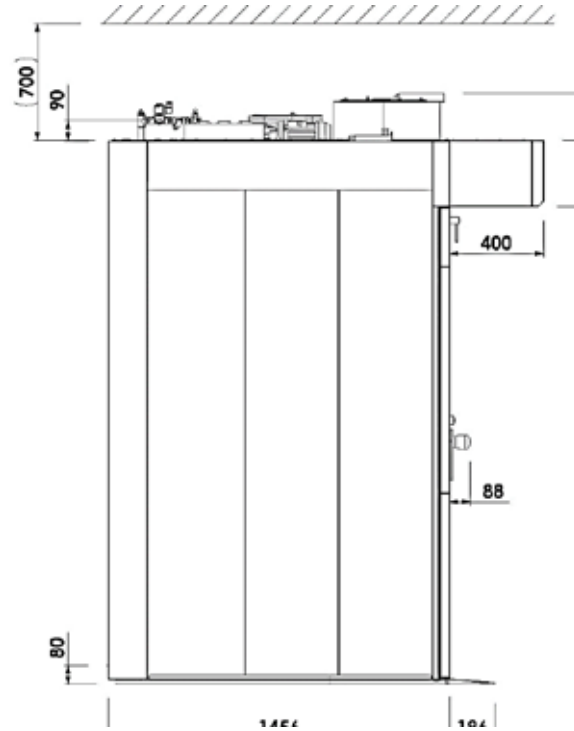

# TOP

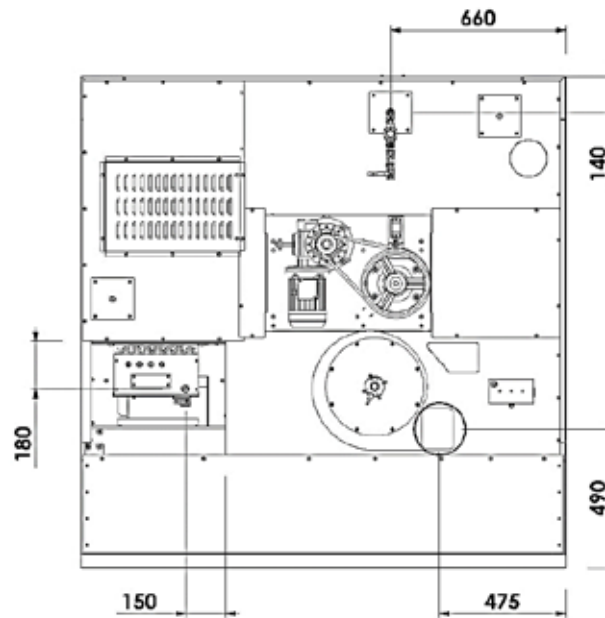

We reserve the right to alter specifications without notice.



**THE  
GOOD  
LADY**

Phone: 1800 183 818 Email: [support@thegoodlady.com.au](mailto:support@thegoodlady.com.au)  
Website: [www.thegoodlady.com.au](http://www.thegoodlady.com.au)