

CS401-Assembly Language

(Solved Subjective)

LECTURE FROM
(23 to 45)

Junaidfzal08@gmail.com
Bc190202640@vu.edu.pk

FOR MORE VISIT
VULMSHELP.COME

JUNAID MALIK
0304-1659294

Question No.1

Define Stack Data Structure? 2 marks

Answer:- (Page 67)

Stack is a data structure that behaves in a first in last out manner. It can contain many elements and there is only one way in and out of the container. When an element is inserted it sits on top of all other elements and when an element is removed the one sitting at top of all others is removed first

Question No.2

How many broad categories video services are classified? 2 marks

Answer:- (Page 149)

Video services are classified into two broad categories; graphics mode services and text mode services.

Question No.3

What is programmer view of processor? 2 marks

Answer:- (Page 32)

The processor will blindly go there, where we mention even if it contains data and not code

Question No.4

INT-14-Serial-READ CHARACTER FORM PORT uses which two 8-bit registers to return to result? 2 marks

Answer:- (Page 172)

Return:

AH = line status

AL = received character if AH bit 7 clear

Question No.5

Difference between two instructions? 3 marks

mov byte [num1],5

mov word [num1],5

Answer:-

In first instruction, The variable num1 is treated as a byte and similarly 5 is also treated as byte.

In 2nd instruction, The variable num1 is treated as a word and similarly 5 is also treated as word.

Question No.6

Write two different modes of video services of BIOS? Differentiate between both modes? 3 Marks

Answer:- (Page 149)

Video services are classified into two broad categories; graphics mode services and text mode services. In graphics mode a location in video memory corresponds to a dot on the screen. In text mode this relation is not straightforward. The video memory holds the ASCII of the character to be shown and the actual shape is read from a font definition stored elsewhere in memory

Question No.7

Define Triple Fault? 3 Marks

Question No.8

Difference between roles of segment-selector and segment-descriptor? 3 Marks

Answer:- (Page 175)

Role of selector is to select on descriptor from the table of descriptors and the role of descriptor is to define the actual base address.

Question No.9

How value of Stack pointer (SP) changes after every PUSH or POP instructions? 5 Marks

Answer:- (Page 68)

Whenever an element is pushed on the stack SP is decremented by two and when we pop from it, it increments by 2 as in case of decrementing stack. A decrementing stack moves from higher addresses to lower addresses as elements are added in it

Question No.10 5 Marks

How to write disk sector using INT 13 service?

Answer:- (Page 156)

INT 13 - DISK - WRITE DISK SECTOR(S)

AH = 03h

AL = number of sectors to write (must be nonzero)

CH = low eight bits of cylinder number

CL = sector number 1-63 (bits 0-5)

high two bits of cylinder (bits 6-7, hard disk only)

DH = head number

DL = drive number (bit 7 set for hard disk)

ES:BX -> data buffer

Return:

CF = error flag

AH = error code

AL = number of sectors transferred

Question No.11

Write down instructions for data movement and arithmetic operations in Motorola 68K Processor? 5 Marks

Answer:- (Page 191)

Data Movement

EXG D0, D2

MOVE.B (A1), (A2)

MOVEA (2222).L, A4

MOVEQ #12, D7

Arithmetic

ADD D7, (A4)

CLR (A3) (set to zero)

CMP (A2), D1

ASL, ASR, LSL, LSR, ROR, ROL, ROXL, ROXR (shift operations)

Question No.12 **5 Marks**

How to load program using INT21 service?

Answer:- (Page 165)

INT 21 - LOAD AND/OR EXECUTE PROGRAM

AH = 4Bh

AL = type of load (0 = load and execute)

DS:DX -> ASCIZ program name (must include extension)

ES:BX -> parameter block

Return:

CF = error flag

AX = error code

Question No.13

Difference between serial and parallel communication.

Answer:- (Page 171)

Serial port is a way of communication among two devices just like the parallel port. The basic difference is that whole bytes are sent from one place to another in case of parallel port while the bits are sent one by one on the serial port in a specially formatted fashion.

Question No.14

Write brief about INT 13 – Extended READ SERVICES

Answer:- (Page 157)

INT 13 - INT 13 Extensions - EXTENDED READ

AH = 42h

DL = drive number

DS:SI -> disk address packet

Return:

CF = error flag

AH = error code

Question No.15

Describe briefly INT 3 functionality.

Answer:- (Page 133)

INT 3 is a Debug Interrupt. INT 3 has a single byte opcode so it can replace any instruction. This allows it to replace any instruction whatsoever. This is also called break point interrupt.

Question No.16

How to create or Truncate File using INT 21 Service?

Answer:- (Page 161)

INT 21 - CREATE OR TRUNCATE FILE

AH = 3Ch

CX = file attributes

DS:DX -> ASCIZ filename

Return:

CF = error flag

AX = file handle or error code

Question No.17

Define condition when ZF is set or clear? 2 marks

Answer:- (Page 41)

When the source is subtracted from the destination and both are equal the result is zero and therefore the zero flag is set.

Question No.18

Types of User descriptor?

Question No.19

System descriptor?

Answer:- (Page 182)

The S bit tells that this is a system descriptor

Question No.20

Define interrupt INT 0*80

Answer:- (Page 145)

int 0x80 ; multitasking kernel interrupt

Question No.21

Draw serial port connector? 5marks

Answer:- (Page 171)

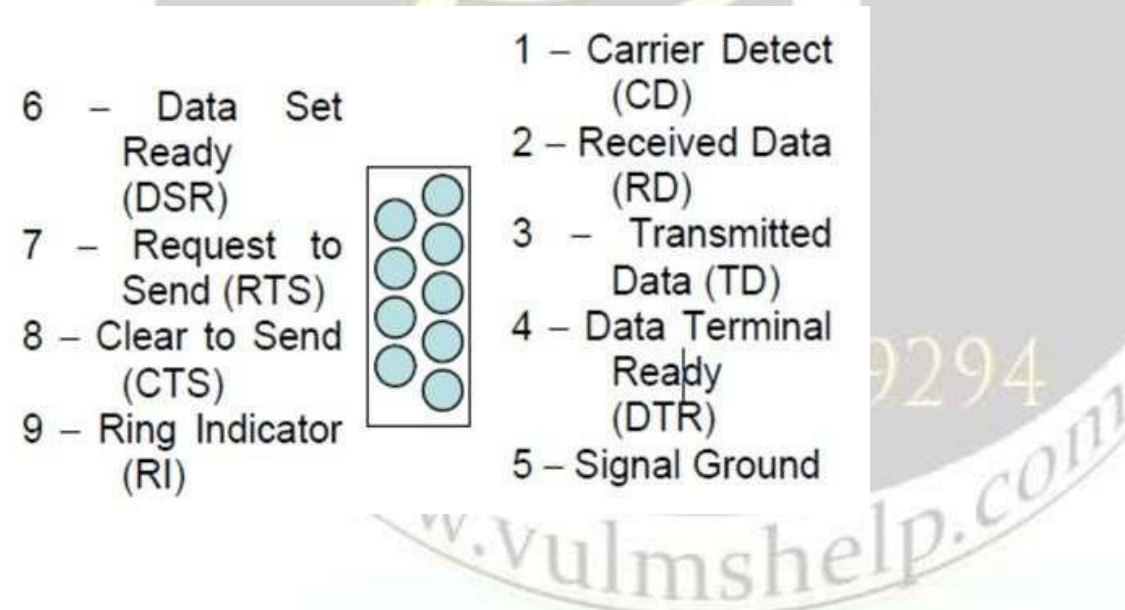

Question No.22

Define extended ADD with carry? 5 marks

Answer:- (Page 57)

The instruction is ADC or “add with carry.” Normal addition has two operands and the second operand is added to the first operand. However ADC has three operands. The third implied operand is the carry flag. The ADC instruction is specifically placed for extending the capability of ADD. Numbers of any size can be added using a proper combination of ADD and ADC. ADC first adds the carry flag to AX and then adds BX to AX. Therefore the last carry is also included in the result.

Question No.23**Data movement? 5 marks****Answer:- (Page 13)**

These instructions are used to move data from one place to another. These places can be registers, memory, or

even inside peripheral devices. Some examples are:

```
mov ax, bx
```

```
lad 1234
```

Question No.24**What is speed of multitasking?****Answer:- (Page 143)**

When new threads are added, there is an obvious slowdown in the speed of multitasking. To improve that, We can change the timer interrupt frequency. The following can be used to set to an approximately 1ms interval.

```
mov ax, 1100
```

```
out 0x40, al
```

```
mov al, ah
```

```
out 0x40, al
```

This makes the threads look faster. However the only real change is that the timer interrupt is now coming more frequently

Question No.25**What is the function of ES and DS in video mode?****Answer:- (Page 81)**

Both DS and ES can be used to access the video memory. However we commonly keep DS for accessing our data, and load ES with the segment of video memory.

Question No.26**Device drivers and its routine****Answer:- (Page 166)**

Device drivers are operating system extensions that become part of the operating system and extend its services to new devices.

Question No.27**INT 13 Read sector into memory****Answer:- (Page 156)****INT 13 - DISK - READ SECTOR(S) INTO MEMORY****AH = 02h****AL = number of sectors to read (must be nonzero)****CH = low eight bits of cylinder number****CL = sector number 1-63 (bits 0-5)****high two bits of cylinder (bits 6-7, hard disk only)****DH = head number****DL = drive number (bit 7 set for hard disk)**

ES:BX -> data buffer

Return:

CF = error flag

AH = error code

AL = number of sectors transferred

Question No.28

SCAS instruction? How it checks null string?

Answer:- (Page 92,95)

SCAS compares a source byte or word in register AL or AX with the destination string element addressed by ES:DI and updates the flag. We use SCASB with REPNE and a zero in AL to find a zero byte in the string. In CX we load the maximum possible size, which are 64K bytes.

Question No.29

Function of 9 pin DB 9 Connectors?

Answer:- (Page 171)

- 1 – Carrier Detect
- 2 – Received Data
- 3 – Transmitted
- 4 – Data Terminal Ready
- 5 – Signal Ground
- 6 – Data Set Ready
- 7 – Request to Send
- 8 – Clear to Send
- 9 – Ring Indicator

Question No.30

What flags are used in AND operation

Answer:-

Affected Flag of AND are:
CF, OF, PF, SF, ZF and AC.

Question No.31

What do you mean by calling conventions?

Answer:- (Page 187)

To interface an assembly routine with a high level language program means to be able to call functions back and forth. And to be able to do so requires knowledge of certain behavior of the HLL when calling functions. This behavior of calling functions is called the calling conventions of the language. Two prevalent calling conventions are the C calling convention and the Pascal calling convention.

Question No.32

Why we say that stack behaves like LIFO? (Marks 2)

Answer:-

Because the structure of stack is based on first in last out. The value which we push last on the stack should be pop first.

Question No.33

What are the services provided by INT 0x18? (Marks 2)

Question No.34

Which register's used by "INT 21-CREATE OR TRUNCATE FILE" to read service number and file attributes? (Marks 2)

Answer:-

AH = 3Ch

CX = file attributes

DS:DX -> ASCIZ filename

Question No.35

What do you mean by faulty instruction? (Marks 2)

Question No.36

Which instructions are to call a subroutine and to get back to the same point where the function was called? Explain these instruction with help of an Examples.(Marks 3)

Answer:- (Page 64)

CALL is used to call a subroutine and to get back RET is used. CALL takes a label as argument and execution

starts from that label, until the RET instruction is encountered and it takes execution back to the instruction following the CALL.

FOR EXAMPLE:

```
[org 0x0100]
```

```
jmp start
```

```
num: dw 1,2,3,4,5,6,7,8,9,10,11,12,13,14,15,16,17,18,19,20
```

```
sum: add dx, [num+bx]
```

```
add bx,2
```

```
cmp bx,40
```

```
jne sum
```

```
ret
```

```
start: mov dx,0
```

```
mov bx,0
```

```
call sum
```

```
mov ax,0x4c00
```

```
int 0x21
```

Question No.37

With reference to the multitasking program" TSR Caller" writes against each instruction what they do. (Marks 3)

MOVE al, [chars+bx]

Move [es: 40], al

INC bx

Answer:- (Page 146)

MOVE al, [chars+bx]

It will read next character from the declared variable char.

Move [es: 40], al

Answer: It will print the data at the specified place

INC bx

Answer: It will increment the register bx by 1

Question No.38

Consider the function “int divide (int divided, int divisor)” declared in C, write the code to call this function from assembly language? (Marks 3)

Answer:- (Page 187)

To call this function from assembly we have to write.

```
push dword [mydivisor]
push dword [mydividend]
call _divide
add esp, 8
; EAX holds the answer
```

Question No.39

How many type of Granularity are there? (Marks 3)

Answer:-

In particular two types of granularity have been delineated aggregation and abstraction.

Question No.40

Write an assembly language program that clears the computer screen? (marks 5)

Answer:- (Page 82)

```
; clear the
screen [org
0x0100]
mov ax, 0xb800; load video base in ax
mov es, ax      ; point es to video base
mov di, 0       ; point di to top left column
nextchar: mov word [es:di], 0x0720 ; clear next char on screen
add di, 2       ; move to next screen location
cmp di, 4000    ; has the whole screen cleared
jne nextchar    ; if no clear next position
mov ax, 0x4c00  ; terminate program
int 0x21
```

Question No.41

Write an assembly language program for drawing a line in graphic mode of video service? (Marks 5)

Answer:- (Page 152)

```
; draw line in graphics
mode [org 0x0100]
mov ax, 0x000D ; set 320x200 graphics
mode int 0x10 ; bios video services
```

```
mov ax, 0x0C07 ; put pixel in white
color xor bx, bx ; page number 0
mov cx, 200 ; x position 200
mov dx, 200 ; y position 200
l1: int 0x10 ; bios video
services dec dx ; decrease y
position
loop l1 ; decrease x position and
repeat mov ah, 0 ; service 0 – get
keystroke int 0x16 ; bios keyboard
services mov ax, 0x0003 ; 80x25 text
mode int 0x10 ; bios video services
mov ax, 0x4c00 ; terminate
program int 0x21
```

Question No.42

Write down the movement instruction for SUN SPARK processor? Provide at least two examples? (Marks 5)

Answer:- (Page 193)

Data Movement

LDSB [rn], rn (load signed byte)

LDUW [rn], rn (load unsigned word)

STH [rn], rn (store half word)

Question No.43

How many calling conversion also tell the names? (2)

Answer:- (Page 187)

Two prevalent calling conventions are the C calling convention and the Pascal calling convention.

Question No.44

Sun Spark Properties? 5

Answer:- (Page 192)

SPARC stands for Scalable Processor Architecture. SPARC is a 64bit processor. Its byte order is user settable and even on a per program basis. There are 8 global registers and 8 alternate global registers. One of them is active at a time and accessible as g0-g7. SPARC introduces a concept of register window. One window is 24 registers and the active window is pointed to by a special register called Current Window Pointer (CWP).

Question No.45

How many bytes floppy root directory entry has? (2)

Answer:

224 bytes for a 3 1/2 inch floppy

Question No.46

Base Register Function?5

Answer:- (Page 35)

A base register is used in brackets and the actual address accessed depends on the value contained in that register. For example "mov [bx], ax" moves the two byte contents of the AX register to the address contained in the BX register in the current data segment. The instruction "mov [bp], al" moves the one byte content of the AL register to the address contained in the BP register in the current stack segment.

Question No.47

Chargen Services Attributes? 5

Answer:- (Page 150)

INT 10 - VIDEO - GET FONT INFORMATION

AX = 1130h

BH = pointer specifier

Return:

ES:BP = specified pointer

CX = bytes/character of on-screen font

DL = highest character row on screen

Question No.48

Difference SHR&SAR? 2

Answer:- (Page 150)

The sign bit is NOT retained in SHR operation while in SAR The sign bit is retained.

Question No.49

Imported and exported symbols in NASM? 2

Answer:- (Page 189)

In NASM an imported symbol is declared with the extern directive while and exported symbol is declared with the global directive.

Question No: 50 (Marks: 5)

In the context of " INT 13 - DISK - WRITE DISK SECTOR(S)" fill the blanks by choosing the correct answer against each blank space from the list given at the bottom.

Answer:- (Page 156)

AH = 03h

AL = number of sectors to write (must be nonzero)

CH = bits of low eight cylinder number

CL = sector number 1-63 (bits 0-5)

high two bits of cylinder (bits 6-7, hard disk only)

DH = head number

DL = drive number (bit 7 set for hard disk)

ES:BX -> data buffer

(Number of sectors to write, head number , 03h, data buffer , low eight bits of cylinder number)

Question No.51

What is CALL instruction work?

Answer:- (Page 64)

CALL takes a label as argument and execution starts from that label, until the RET instruction is encountered and it takes execution back to the instruction following the CALL. The RET works regardless of the CALL and the CALL works regardless of the RET.

Question No: 52 (Marks: 2)

Write instructions to do the following. Copy contents of memory location with offset 0025 in the current data segment into AX.

Answer:-

Mov ax , [0025]

Question No.53

Define the multitasking (2)

Answer:-

Multitasking is processing multiple tasks at one time

Question No.54

Define the protected mode (3)

Answer:- (Page 175)

Switching processor in the newer 32bit mode is a very easy task. Just turn on the least significant bit of a new register called CR0 (Control Register 0) and the processor switches into 32bit mode called protected mode.

Question No.55

What is disk driver and why disk driver are necessary in BIOS (5)

Answer:- (Page 156)

BIOS disk services used to directly see the data stored in the directory entries by DOS. For this purpose we will be using the BIOS disk services.

Question No.56

Writ the code of break point interrupt routine (5)

Answer: Page 136 (Example 10.2)

Question No.57

Define the trap flag (3)

Answer:- (Page 133)

If the trap flag is set, the after every instruction a type 1 interrupt will be automatically generated. This is like the divide by zero interrupt which was never explicitly invoked but it came itself.

Question No.58

From what purpose INT 1 is reserved (2)

Answer:- (Page 105)

This interrupt is used in debugging with the trap flag. If the trap flag is set the Single Step Interrupt is generated after every instruction. By hooking this interrupt a debugger can get control after every instruction and display the registers etc.

Question No: 59 (Marks: 5)

Write assembly language instructions to set the timer interrupt frequency at 1 ms.

Answer: (Page 143)

```
mov ax, 1100
out 0x40, al
mov al, ah
out 0x40, al
```

Question No.60

When we multiply two 8 bit numbers, in how many bits there answer will be? (2 Marks)

Answer:-

16 bit

Question No: 61 (Marks: 5

Write down the operations of CMP instruction? (2)

Answer:- (Page 39)

The operation of CMP is to subtract the source operand from the destination operand, updating the flags without changing either the source or the destination.

Question No.62

Define serial port? (2 Marks)

Question No.63

Difference between serial and parallel communication.

Answer:- (Page 171)

Serial port is a way of communication among two devices just like the parallel port

Question No.64

How to reset disk file system using INT 13 Disk Rest services? (3 Marks)

Answer:- (Page 156)

INT 13 - DISK - RESET DISK SYSTEM

AH = 00h

DL = drive

Return:

CF = error flag

AH = error code

Question No.65

Why IF & TF are cleared? (3 Marks)

Answer:- (Page 133)

The interrupt mechanism automatically clears IF and TF otherwise there would an infinite recursion of the single step interrupt. The TF is set in the flags on the stack so another interrupt will comes after one more instruction is executed after the return of the interrupt.

Question No.66

Describe “Indexed Register Indirect + offset” addressing mode with example? (3 Marks)

Answer:- (Page 136)

An index register is used with a constant offset in this addressing mode. The value contained in the index register is added with the constant offset to get the effective address. For example “mov [si+300], ax” moves the word contained in AX to the offset attained by adding 300 to SI in the current data segment and the instruction “mov [di+300], al” moves the byte contained in AL to the offset attained by adding 300 to DI in the current data segment.

Question No.67

Write the algorithm of bubble sort in your words? (5 Marks)

Answer:- (Page 46)

In this algorithm we compare consecutive numbers. If they are in required order e.g. if it is a descending sort and the first is larger than the second, then we leave them as it is and if they are not in order, we swap them. Then we do the same process for the next two numbers and so on till the last two are compared and possibly swapped.

Question No.68

List only five BIOS video services used in text mode? (5 Marks)

Answer:- (Page 149)

INT 10 - VIDEO - SET TEXT-MODE CURSOR
SHAPE INT 10 - VIDEO - SET CURSOR
POSITION INT 10 - VIDEO - SCROLL UP
WINDOW INT 10 - VIDEO - SCROLL DOWN
WINDOW INT 10 - VIDEO - WRITE STRING

Question No: 69 (Marks: 3)

Write the name three flags which are not used for mathematical operations.

Answer:- (Page 133)

The three flags not used for mathematical operations are the direction flag, the interrupt flag and the trap flag.

Question No: 70 (Marks: 3)

“INT 13 - DISK - GET DRIVE PARAMETERS” uses which registers to return *error flag* and *error number*.

Answer:- (Page 156)

CF = error flag
AH = error code

Question No: 71 (Marks: 3)

Who is responsible for removing the parameter from the stack when we call a function in C and Pascal?

Answer:- (Page 187)

In C the caller removes the parameter while in Pascal the callee removes them. The C scheme has reasons pertaining to its provision for variable number of arguments.

Question No.72

Which register is used as thread local variable? (2)

Answer:- (Page 141)

SP (stack pointer) register used as thread local variable

Question No.73

what is the difference in Motorola 64 k and x86 processors? 5 marks

Answer:- (Page 191)

The instructions are very similar however the difference in architecture evident. 68K processors have 16 23bit general purpose registers named from A0-A7 and D0-D7. A0-A7 can hold addresses in indirect memory accesses. These can also be used as software stack pointers. Stack in 68K is not as rigid a structure as it is in x86.

Question No.74

Which register is called a scratch register? 2 marks

Answer:- (Page 187)

EAX, ECX, EDX, FS, GS, EFLAGS, and any other registers.

Question No.75

What is scheduler

Answer:- (Page 141)

INT 08 that is saving and restoring the registers is called the scheduler.

Question No.76

VESA INT 10 service

Answer:- (Page 180)

INT 10 – VESA – Get SuperVGA Information

INT 10 – VESA – Get SuperVGA Mode Information

INT 10 – VESA – Set VESA Video Mode

Question No: 77 (Marks: 3)

VESA service "INT 10 – VESA – Get SuperVGA Information" uses which registers to return the result?

Answer:- (Page 180)

To return the result, "INT 10 – VESA – Get SuperVGA Information" uses:

Return:

AL = 4Fh if function supported

AH = status

Question No.78

What is Stack overflow

Answer:- (Page 187)

The strong argument in favour of callee cleared stacks is that the arguments were placed on the stack for the subroutine, the caller did not need them for itself, so the subroutine is responsible for removing them. Removing the arguments is important as if the stack is not cleared or is partially cleared the stack will eventually become full, SP will reach 0, and thereafter wraparound producing unexpected results. This is called stack overflow.

Question No.79

Difference between naming convention of C language & Pascal (5).

Answer:- (Page 187)

C pretends an underscore to every function or variable name while Pascal translates the name to all uppercase. C++ has a weird name mangling scheme that is compiler dependent. To avoid it C++ can be forced to use C style naming with extern "C" directive.

Question No.80**Difference between Data Bus & Control bus (5).****Answer:- (Page 9)**

Data bus is used to move the data from the memory to the processor in a read operation and from the processor to the memory in a write operation. While one line of the bus is used to inform the memory about whether to do the read operation or the write operation. These lines are collectively known as the control bus

Question No: 81 (Marks: 2)

Define short jump

Answer:- (Page 46)

If the offset is stored in a single byte as in 75F2 with the opcode 75 and operand F2, the jump is called a short jump.

Question No.82**In what order C & Pascal instruction are passed to routines. (3).****Answer:- (Page 187)**

In C parameters are pushed in reverse order with the rightmost being pushed first. While in Pascal they are pushed in proper order with the leftmost being pushed first.

Question No.83**Describe Debugger in the term of Trap Flag (5).****Answer:- (Page 133)**

If the trap flag is set, the after every instruction a type 1 interrupt will be automatically generated. The debugger is made using this interrupt. It allows one instruction to be executed and then return control to us. It has its display code and its code to wait for the key in the INT 1 handler. Therefore after every instruction the values of all registers are shown and the debugger waits for a key.

Question No: 84 (Marks: 2)**Write instruction to allocate space for 32 PCBs.****Answer:- (Page 141)**

pcb: times 32*16 dw 0 ; space for 32 PCBs

Question No.85**What the processor vision about video devices. (3).****Answer:- (Page 80)**

The video device is seen by the computer as a memory area containing the ASCII codes that are currently displayed on the screen and a set of I/O ports controlling things like the resolution, the cursor height, and the cursor position.

Question No.86**lds si, [bp+4] from DS and SI will load? (2)****Answer:- (Page 97)**

lds si, [bp+4] will load SI from BP+4 and DS from BP+6.

Question No.87

What is processor control block answer in one line (2).

Answer:- (Page 140)

The space where all registers of a task are stored is called the process control block or PCB.

Question No.88

Define the debugger. How to run the debugger tell the command, and all its parts? (5)

Answer:-

A debugger is a computer program that lets you run your program, line by line and examine the values of variables or look at values passed into functions and let you figure out why it isn't running the way you expected it to.

We can run debugger by pressing F1 and F2. The debugger shows the values of registers, flags, stack, our code, and one or two areas of the system memory as data. Debugger allows us to step our program one instruction at a time and observe its effect on the registers and program data.

Question No.89

Define context switching 2 marks

Answer:- (Page 141)

INT 08 that is saving and restoring the registers is called the scheduler and the whole event is called a context switch.

Question No.90

Write the algorithm of multiplication of two 4 bits number? (3)

Answer:- (Page 51)

We take the first digit of the multiplier and multiply it with the multiplicand. As the digit is one the answer is the multiplicand itself. So we place the multiplicand below the bar. Before multiplying with the next digit a cross is placed at the right most place on the next line and the result is placed shifted one digit left.

Question No.91

How threads are register in the scheduler? (3)

Question No.92

Format of the interrupt descriptor

Answer:- (Page 182)

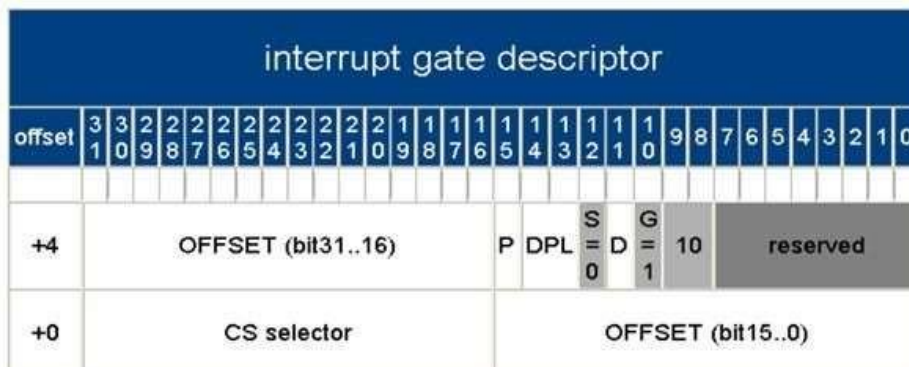

Question No.93

Define Faulty Instructions [3marks]

Question No.94

Write down purpose of JNZ instruction? (2)

Answer:- (Page 32)

The JNZ instruction is from the program control group and is a conditional jump, meaning that if the condition NZ is true (ZF=0) it will jump to the address mentioned and otherwise it will progress to the next instruction.

Question No.95

What are the ranges of addressable memory in protected mode?

Question No.96

Define Device drivers. Why device drivers are used when BIOS already have all available codes. write its need[5marks]

Answer:- (Page 166)

Device drivers are operating system extensions that become part of the operating system and extend its services to new devices. Device drivers in DOS are very simple. They just have their services exposed through the file system interface.

Question No.97

There was fill in blanks question with 10 marks. The choice was given at bottom.

Serial Port is also accessible via _____ ports , _____ is accessible via ports 3F8-3FF while _____ is accessible via 2F8 -2FF.

The first register at 3F8 is the _____ holding register if written to and the receiver _____ register if read from.

Other register of our interest include 3F9 whose _____ must be set to enable received data available interrupt and _____ must be set to enable transmitter holding register empty interrupt.

(Transmitter , COM 1 , I/O ports , COM2. bit 0 , Buffer , 3FA)

Answer:- (Page 172)

Serial port is also accessible via I/O ports. **COM1** is accessible via ports 3F8-3FF while **COM2** is accessible via 2F8-2FF. The first register at 3F8 (or 2F8 for the other port) is the **transmitter** holding register if written to and the receiver **buffer** register if read from. Other registers of our interest include 3F9 whose **bit 0** must be set to enable received data available interrupt and **bit 1** must be set to enable transmitter holding register empty interrupt.

Question No.98

Fill in the blanks with proper words[solved] [5 marks]

Answer:- (Page 150)

AH = -09h --

AL = -- character to display –

BH = - page number ---

BL = --- attribute ---

CX =--- number of times to write character –

(09h, page number, number of times to write character, attribute ,character to display,)

Question No.99

Define Hardware Interrupt & I/O ports (5 marks)

Answer:- (Page 113-114)

Hardware interrupts

Hardware interrupts are the real interrupts generated by the external world. there are many devices generating interrupts and there is only one pin going inside the processor and one pin cannot be technically derived by more than one source a controller is used in between called the Programmable Interrupt Controller (PIC).

I/O ports

For communicating with peripheral devices the processor uses I/O ports. There are only two operations with the external world possible, read or write. Similarly with I/O ports the processor can read or write an I/O port. When an I/O port is read or written to, the operation is not as simple as it happens in memory.

Question No.100

DOS allocate memory for program execution and then de-allocate , explain memory management in DOS (10 marks)

Answer:- (Page 121)

At physical address zero is the interrupt vector table. Then are the BIOS data area, DOS data area, IO.SYS, MSDOS.SYS and other device drivers. In the end there is COMMAND.COM command interpreter. The remaining space is called the transient program area as programs are loaded and executed in this area and the space reclaimed on their exit. A freemem pointer in DOS points where the free memory begins. When DOS loads a program the freemem pointer is moved to the end of memory, all the available space is allocated to it, and when it exits the freemem pointer comes back to its original place thereby reclaiming all space. This action is initiated by the DOS service 4C. The second method to legally terminate a program and give control back to DOS is using the service 31. Control is still taken back but the memory releasing part is modified. A portion of the allocated memory can be retained. So the difference in the two methods is that the freemem pointer goes back to the original place or a designated number of bytes ahead of that old position.

Question No.101

What do you mean by data label and code label? (2)

Answer:- (Page 32)

Labels can be used on code as well. Just like data labels they remember the address at which they are used. The assembler does not differentiate between code labels and data labels. The programmer is responsible for using a data label as data and a code label as code.

Question No.102

List some architecture? (3)

Answer:-

iAPX88 architecture

Motorolla 68K
x86 series architecture
SPARC stands for Scalable Processor ARChitecture

Question No.103

What information is required to be provided for the service “INT14-SERIAL WRITE CHARACTER TO PORT” in the following registers? (5 marks)

AH= _____

AL= _____

DX= _____

Answer:- (Page 172)

AH = 01h

AL = character to write

DX = port number (00h-03h)

Question No.104

Which instruction makes trap flag zero? If there is not any then how we make it zero? (5 marks)

Answer:- (Page 133)

There is no instruction to set or clear the trap flag like there are instructions for the interrupt and direction flags. We use two special instructions PUSHF and POPF to push and pop the flag from the stack. We use PUSHF to place flags on the stack, change TF in this image on the stack and then reload into the flags register with POPF.

Question No.105

Division by zero is done by which interrupt.

Answer:- (Page 105)

Division by zero is done by INT 0 interrupt.

Question No.106

Difference between wraparound and physical wraparound and physical wraparounds

Question No.107

How to load AND/ OR execute program using INT 21 services (5)

Answer:- (Page 165)

INT 21 - LOAD AND/OR EXECUTE PROGRAM

AH = 4Bh

AL = type of load (0 = load and execute)

DS:DX -> ASCIZ program name (must include extension)

ES:BX -> parameter block

Return:

CF = error flag

AX = error code

Question No.108

Differentiate synchronous transmission and asynchronous transmission? (3)

Answer:- (Page 103)

Asynchronous means that the interrupts occur, independent of the working of the processor, i.e. independent of the instruction currently executing. Synchronous events are those that occur side by side with another activity.

Question No.109

Following piece of code is taken from the program of scrolling up the screen write against each instruction what it does (5)

```
Mov ax 80
Mu byte [bp+4]
Mov si, ax
Push si
Shl si 1
```

Answer:- (Page 150)

```
mov ax, 80 ; load chars per row in ax
mul byte [bp+4] ; calculate source position
mov si, ax ; load source position in si
push si ; save position for later use
shl si, 1 ; convert to byte offset
```

Question No: 110 (Marks: 2)

Which bit of acknowledge is used to generate IRQ7

Answer:- (Page 125)

Bit "4" of acknowledge is used to generate IRQ7

Question No.111 (Marks: 2) -

INT 14 - SERIAL - READ CHARACTER 8 bit register return result in?

Answer:- (Page 172)

Return:

AH = line status

AL = received character if AH bit 7 clear

Question No: 112 (Marks: 2)

Write types of Devices?

Answer:-

The four types of computer devices are:-

1. input devices
2. output devices
3. storage devices and
4. The central processing unit i.e. C.P.U.

Question No: 113 (Marks: 2)

Explain Divide overflow

Answer:- (Page 85)

If a large number is divided by a very small number it is possible that the quotient is larger than the space provided for it in the implied destination. In this case an interrupt is automatically generated and the program is usually terminated as a result. This is called a divide overflow error;

Question No: 114 (Marks: 5)

The program given below is written in assembly language. Write a program in C to call this assembly routine.

```
[section .text]
global swap
swap:  mov ecx,[esp+4]    ; copy parameter p1 to ecx
       mov edx,[esp+8]  ; copy parameter p2 to edx
       mov eax,[ecx]    ; copy *p1 into eax
       xchg eax,[edx]   ; exchange eax with *p2
       mov [ecx],eax    ; copy eax into *p1
       ret              ; return from this function
```

Answer:- (Page 189)

```
#include <stdio.h>
void swap( int* p1, int* p2 );
int main()
{
int a = 10, b = 20;
printf( "a=%d b=%d\n", a, b );
swap(&a, &b );
printf( "a=%d b=%d\n", a, b );
system( "PAUSE" );
return 0;
}
```

Question No: 115 (Marks: 2)

How interrupts are handled in protected mode.

Answer:- (Page 182)

Handling interrupts in protected mode is also different. Instead of the IVT at physical address 0 there is the IDT (interrupt descriptor table) located at physical address stored in IDTR, a special purpose register. The IDTR is also a 48bit register similar in structure to the GDTR and loaded with another special instruction LGDT.

Question No: 116 (Marks:3)

Three basic steps B/w memory and processor to communicate.

Answer:- (Page 9)

The group of bits that the processor uses to inform the memory about which element to read or write is collectively known as the address bus. Another important bus called the data bus is used to move the data from the memory to the processor in a read operation and from the processor to the memory in a write operation. The third group consists of miscellaneous independent lines used for control purposes.

Question No: 117 (Marks:3)

What is baud rate, tell the parity bit function.

Answer:- (Page 171)

The data starts with a 1 bit called the start bit, then five to eight data bits, an optional parity bit, and one to two 0 bits called stop bits.

The number of data bits, parity bits, and the number of stop bits have to be configured at both ends. Also the duration of a bit must be precisely known at both ends called the baud rate of the communication.

Question No: 118 (Marks:5)

Write the instruction of following

Copy BL into CL

Answer: mov cl, bl

Question No.119

Copy DX into AX

Answer: mov ax, dx

Question No.120

Store 0x12 into AL

Answer: mov al, 0x12

Question No.121

Store 0x1234 into AX

Answer: mov ax, 0x1234

Question No.122

Store 0xFFFF into AX

Answer: mov ax, 0xFFFF

Question No: 123 (Marks: 2)

What dose descriptor 1st 16 bit tell?

Question No: 124 (Marks: 3)

How many Types of granularity also name them?

Answer:-

There are three types of granularity :

1. Data Granularity
2. Business Value Granularity
3. Functionality Granularity

Question No: 125 (Marks:5)

Fill in the blanks with proper words

The GDT itself is an array of **descriptors** where each descriptor is an **8byte** entry.

The base and limit of GDT is stored in a **48bit** register called the **GDTR**.

This register is loaded with a special instruction **LGDT** and is given a memory address from where the **48bits** are fetched.

Read the passage carefully and choose proper word for each blank space from the list given

below . In descriptors the 32bit base is scattered into different places because of compatibility reasons.

The limit is

stored in 20 bits but the ...**G** defines that the limit is in terms of bytes of 4K pages therefore a maximum of 4GB size is possible. The**P**..... must be set to signal that this segment is present in memory. DPL is the descriptor privilege level again related to the protection levels in 386.**D**..... defines that this segment is to execute code is 16bit mode or 32bit mode.**C**is conforming bit that we will not be using.**R**.....signals that the segment is readable. A bit is automatically set whenever the segment is accessed.

(A bit, C bit, G bit, D bit, P bit , R bit, B bit)

Answer: (Page 176)

The 32bit base in both descriptors is scattered into different places because of compatibility reasons. The limit is stored in 20 bits but the G bit defines that the limit is in terms of bytes of 4K pages therefore a maximum of 4GB size is possible. The P bit must be set to signal that this segment is present in memory. DPL is the descriptor privilege level again related to the protection levels in 386. D bit defines that this segment is to execute code is 16bit mode or 32bit mode. C is conforming bit that we will not be using. R signals that the segment is readable. A bit is automatically set whenever the segment is accessed.

AL-JUNAID TECH INSTITUTE



 0304-1659294

www.vulmshelp.com