

ROTOR WIND 2E

8 TRAY ELECTRIC ROTATING BAKING OVEN WITH PROVER
5RW0200



Main Features

The Air Flow crosses a Group of armor plated Heating Elements laid out in order to ensure an Optimal Performance of the Oven.

- 8 Tray Capacity (450 x 650) or (500 x 700)
- High Production
- Steam Exhaust Fan
- Front surface and Baking Chamber Completely in Stainless steel.
- Electromechanical Control Panel which enables the control of:
 - (a) Temperature
 - (b) Ventilation
 - (c) Rack Rotation
 - (d) Supply of Steam
 - (e) Baking Timers
 - (f) shut down/start ups
 - (f) Lighting control

New steam generator embraced in the ventilation area ensures steam is spread inside the chamber in a very homogenous way through the ventilation system.

Prover

5 Tray Prover with Humification (450 x 650) or (500 x 700)



SPECIFICATIONS

Voltage	400 V 3 Phase
Power	13 kw
Weight	410 kg
Plug Supplied	No
Capacity	Rotor Oven 8 x (450 x 650) or (500 x 700) Rotor Prover 5 x (450 x 650) or (500 x 700)
Thermostat	300°C
Baking Volume	2.3 m ²
Warranty	4 Year Warranty (2 yr Labour 4 yr Parts)

ACCESORIES

Computerized Panel

Variable Speed System for Exhaust

DIMENTIONS

External Width	1070mm
External Depth	1440mm
External Height	2260mm



Phone: 1800 183 818 Email: support@thegoodlady.com.au
Website: www.thegoodlady.com.au

FRONT

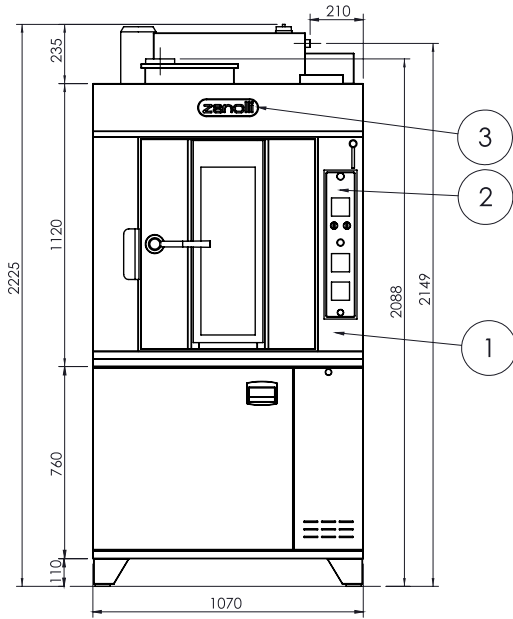

Num. articolo	Quantità	Descrizione
1	1	ROTOR WIND 2E (MODULO)
2	1	SERIGRAFIA RÓTOR WIND 2E
3	1	PANN0370

SIDE

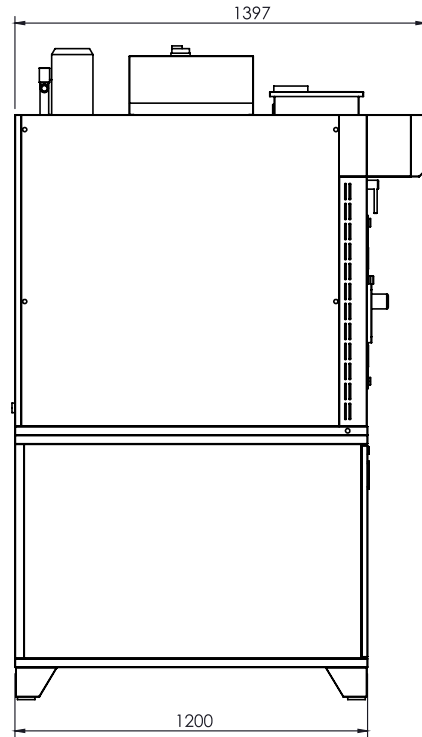

TOP

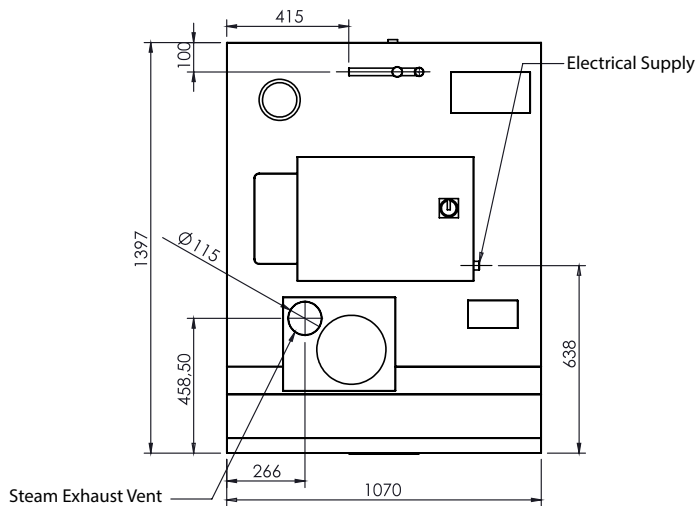

REAR

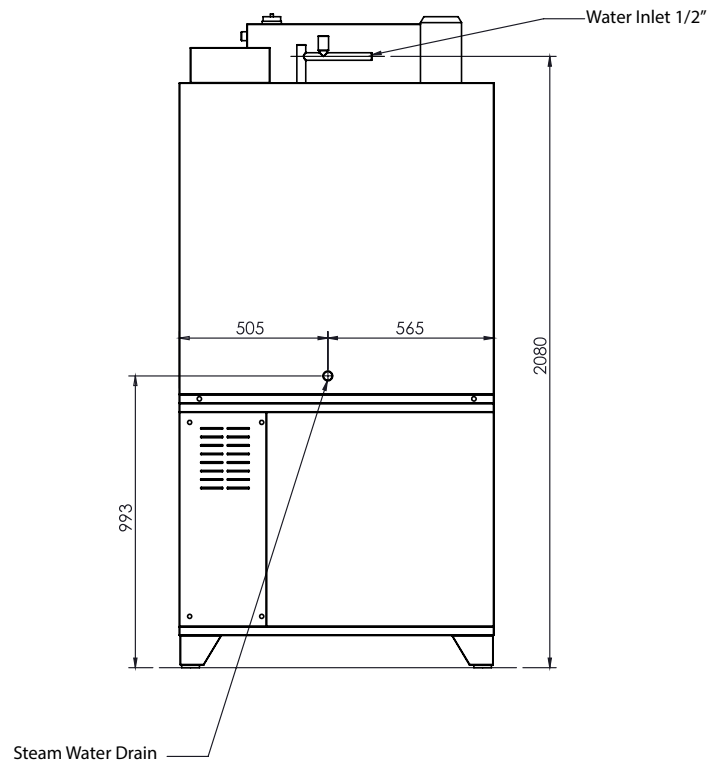

We reserve the right to alter specifications without notice.



**THE
GOOD
LADY**

Phone: 1800 183 818 Email: support@thegoodlady.com.au
Website: www.thegoodlady.com.au