

BERNARDI RS-24

FREESTANDING 24KG DOUBLE ARM MIXER

RS2423029



BERNARDI RS-24

The RS series are a compact freestanding double arm kneading mixer for professional use.

The RS-24 is especially suitable for pizza dough, bread and focaccia. It perfectly kneads and oxygenates 3kg - 24kg of dough to a standard that prides the highest tradition.

The patented compact system enables the double arms to adapt to minimal space requirements and offer exceptional performance.

The RS Series can perfectly combine medium hydration doughs, even up to 75%.

MAIN CHARACTERISTICS

- 2 speed controlled arm moving system (38 and 52 strokes per minute)
- Small-sized double-arm compact system
- Completely extractable arms to ensure emptying and cleaning operations are easier.
- Double-channel emergency stop system ("Safety Torque Off")
- Touch-system control board
- High torque efficiency induction engine

DIMENSIONS

Kneading machine dimensions LxWxH (mm)	450 x 710 x 910
Dimensions with packaging LxWxH (mm)	550 X 810 X 1100

TRY IT
AND FALL IN LOVE 



SPECIFICATIONS

Flour capacity	2kg - 15kg
Kneading capacity	3kg - 24 kg
Bowl capacity	35 litres
Dimensions of bowl	Ø 43 - h 30
Voltage	230 V single-phase, supplied with a 10 amp plug
Power	1500 W
Speed of the arms	2 speed from 38 & 52 strokes/min
Extractable arms	Yes
Extractable bowl	No
Net weight/packing	124 kg / 159 kg
Color	White
Warranty	2 years parts and labour



Phone: 1800 183 818 Email: support@thegoodlady.com.au
Website: www.thegoodlady.com.au

BERNARDI RS-24

FREESTANDING 24KG DOUBLE ARM MIXER

RS2423029

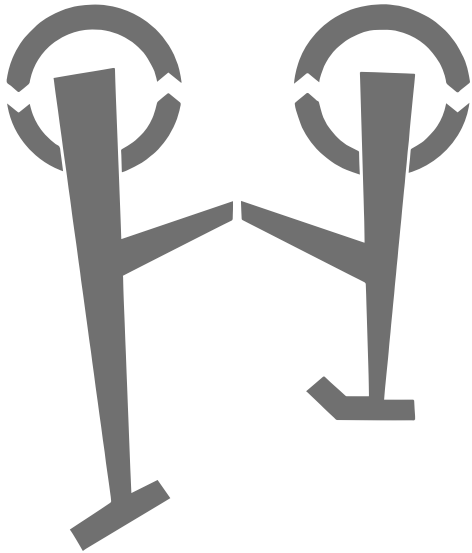

Bernardi patent

- The exclusive compact kneading arm system is a patent of Bernardi.
- This compact system can even make the most difficult recipes such as large leavened kneading and high-hydration dough.

DOUGH	BERNARDI RS-24
BREAD	
PIZZA	
EGG PASTA	
PIZZA NAPOLETANA	
FROLLA PASTA	
BRIOCHEs/VIENNOISERIES	
SHORT PASTA	
CROISSANTS	
PANETTONE	
HIGH HYDRATION DOUGH	

- The maximum kneading capacity refers to a flour/liquid ratio of 1:0.6 and may vary according to the recipe
- The minimum kneading capacity is approximately the 20% of the maximum capacity
- For tough dough - less than 55% hydration - like egg pasta and mother yeast, reduce the maximum capacity of flour by 50%

FRONT

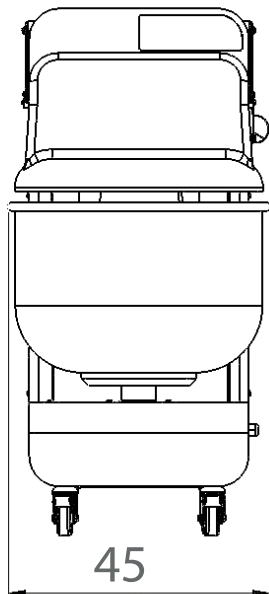

SIDE

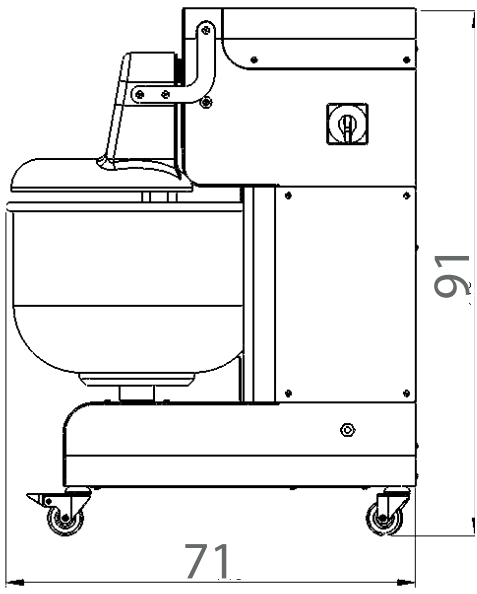

Phone: 1800 183 818 Email: support@thegoodlady.com.au
 Website: www.thegoodlady.com.au