

**BOEING** **747**  
**OPERATIONS MANUAL**

**AIRPLANE GENERAL  
PRINCIPAL DIMENSIONS**

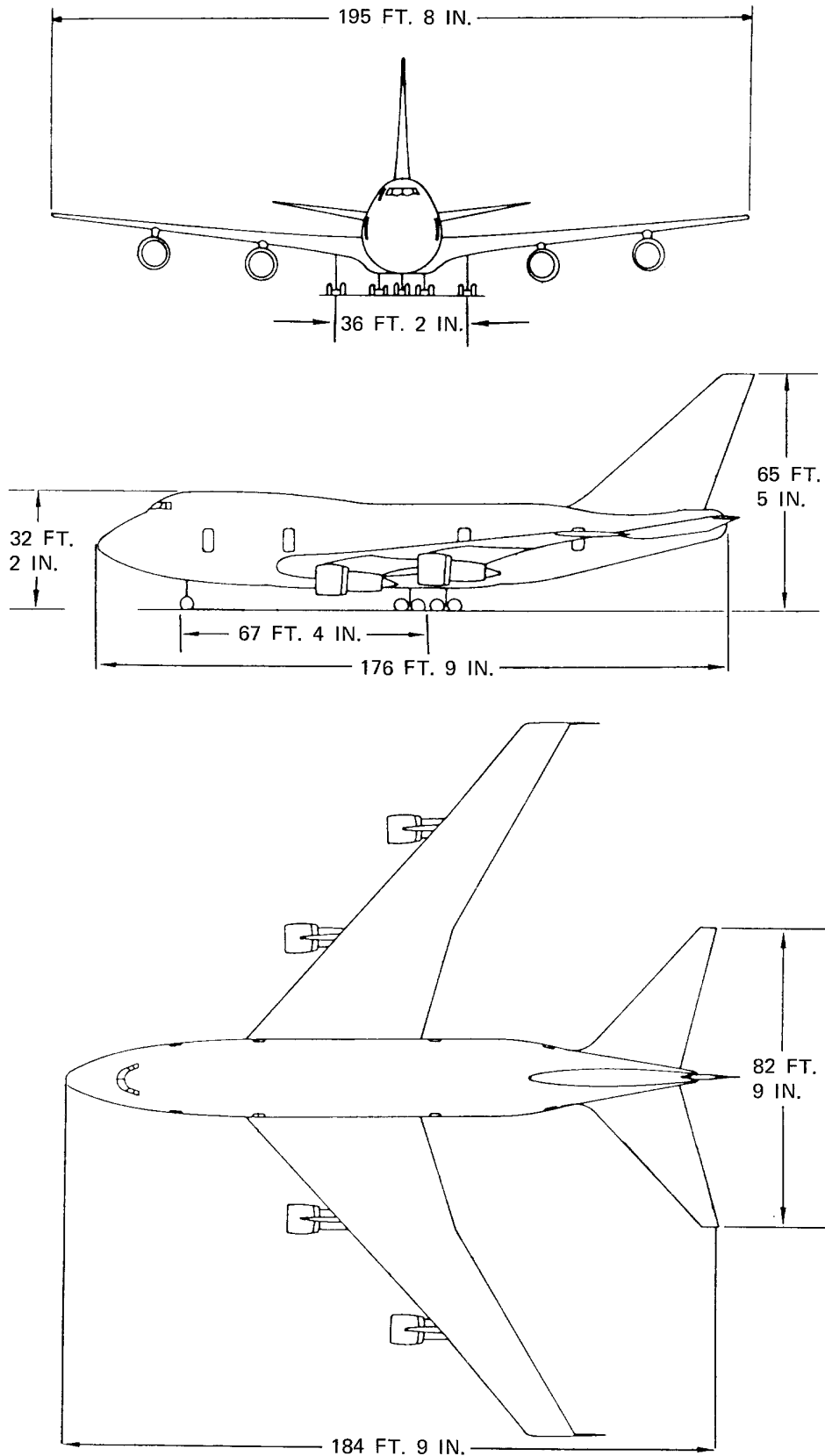

**PRINCIPAL DIMENSIONS**

B89983

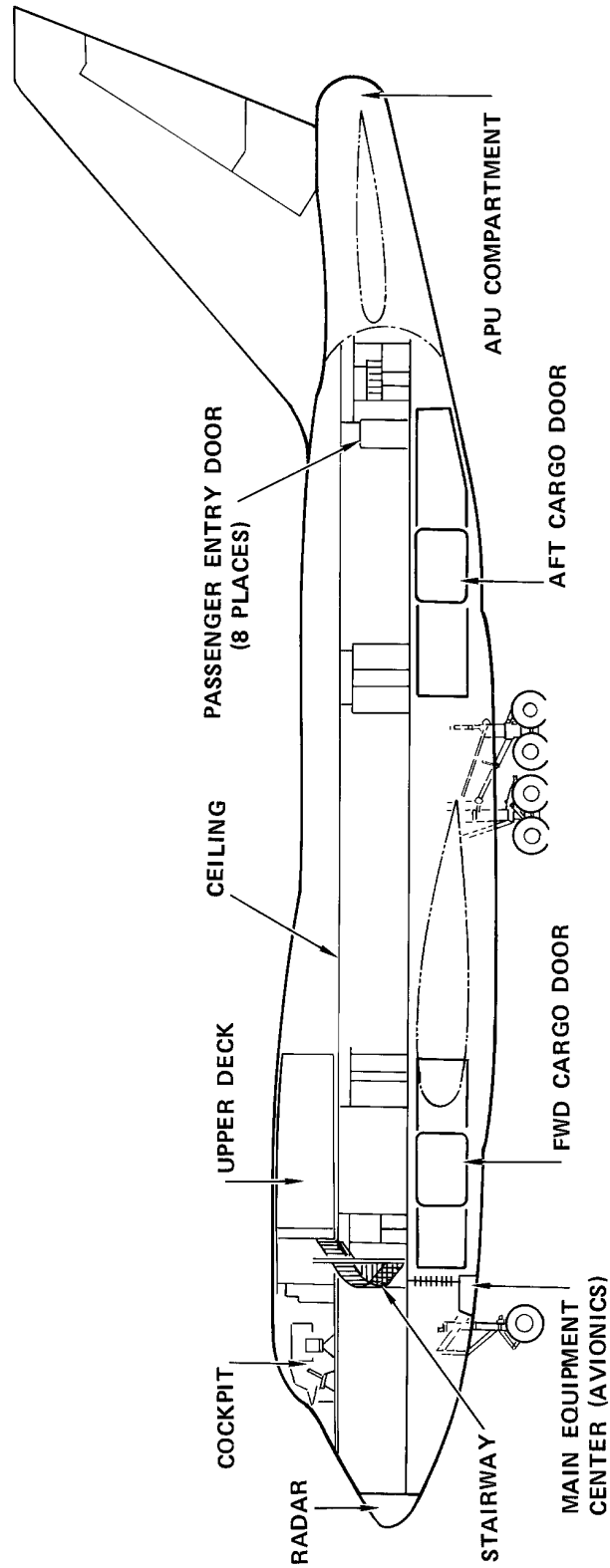

**GENERAL ARRANGEMENT**

Use maximum width available.  
 Use of minimum width will cause  
 excessive tire slippage and  
 scrubbing.

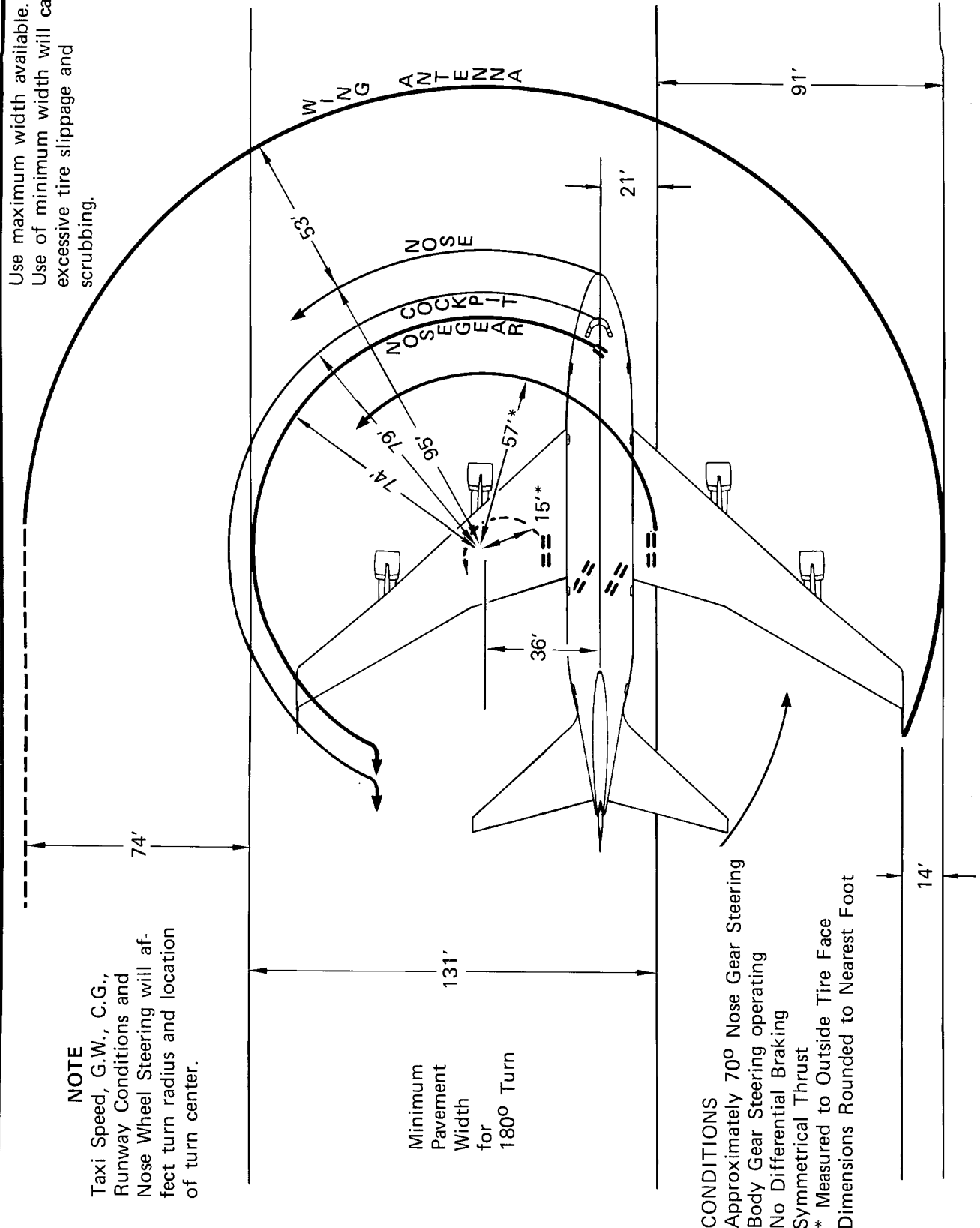

**NOTE**  
 Taxi Speed, G.W., C.G.,  
 Runway Conditions and  
 Nose Wheel Steering will af-  
 fect turn radius and location  
 of turn center.

Minimum  
 Pavement  
 Width  
 for  
 180° Turn

**CONDITIONS**  
 Approximately 70° Nose Gear Steering  
 Body Gear Steering operating  
 No Differential Braking  
 Symmetrical Thrust  
 \* Measured to Outside Tire Face  
 Dimensions Rounded to Nearest Foot

**747 SP  
 TURNING RADIUS**



AIRPLANE GENERAL  
COCKPIT PANELS

THE FOLLOWING PAGES SHOW COCKPIT PANELS  
FOR AIRPLANE SERIAL NUMBER:

21648

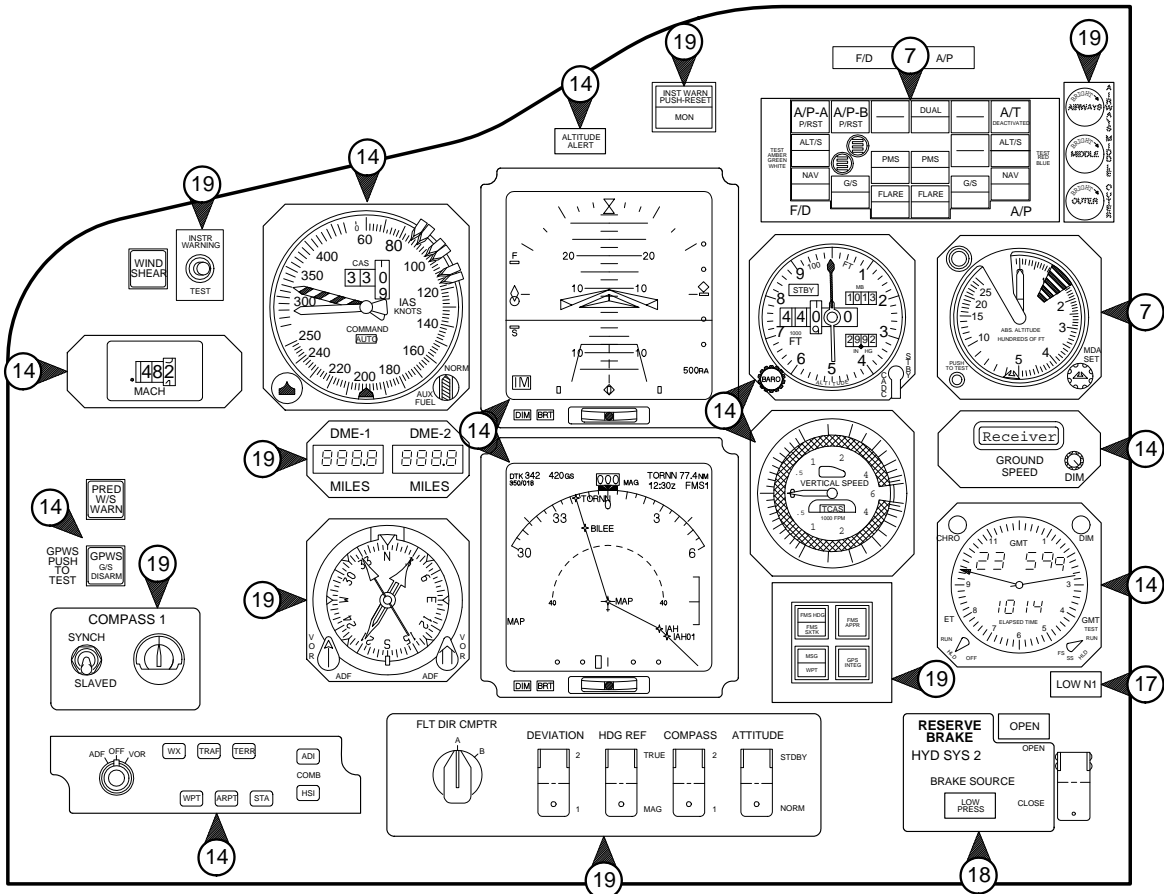

**CAPTAIN'S INSTRUMENT PANEL**

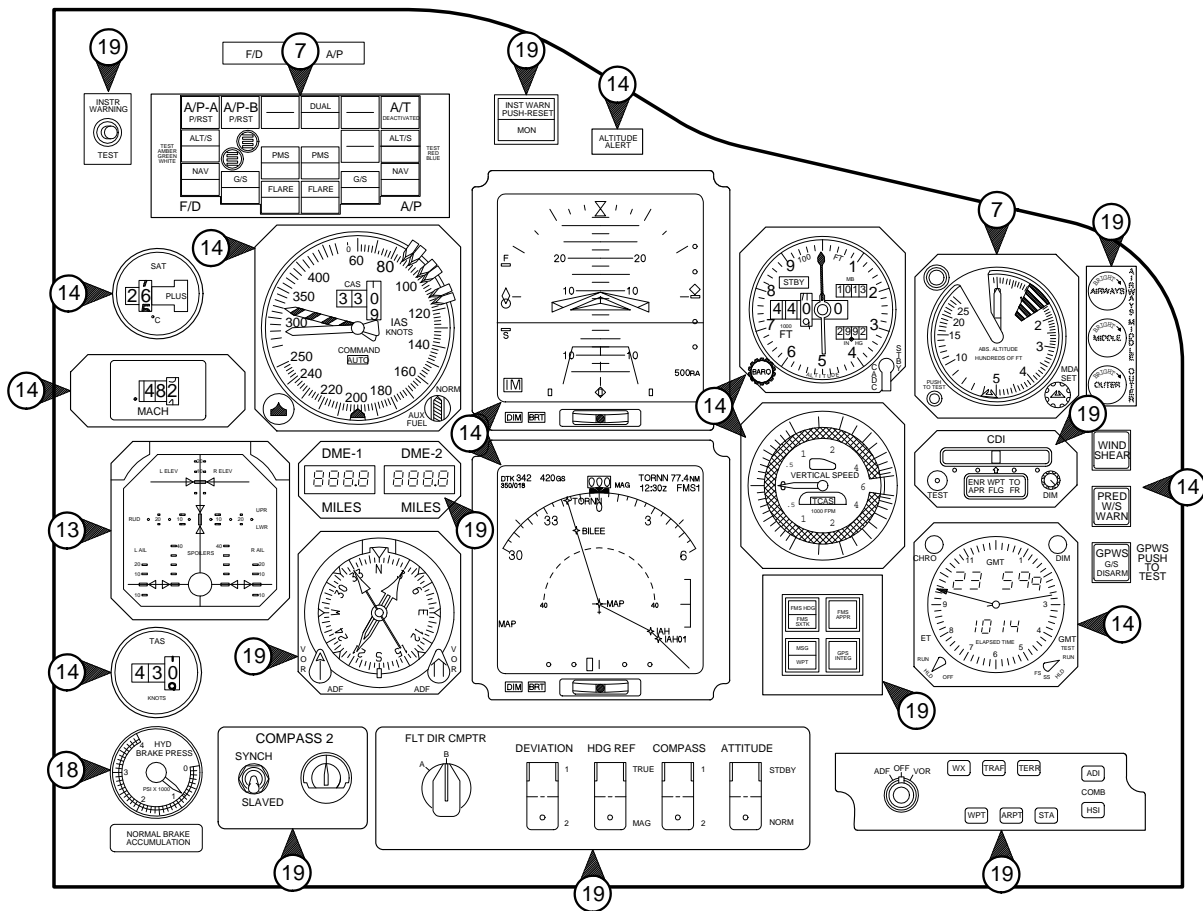

**FIRST OFFICER'S INSTRUMENT PANEL**

1875613

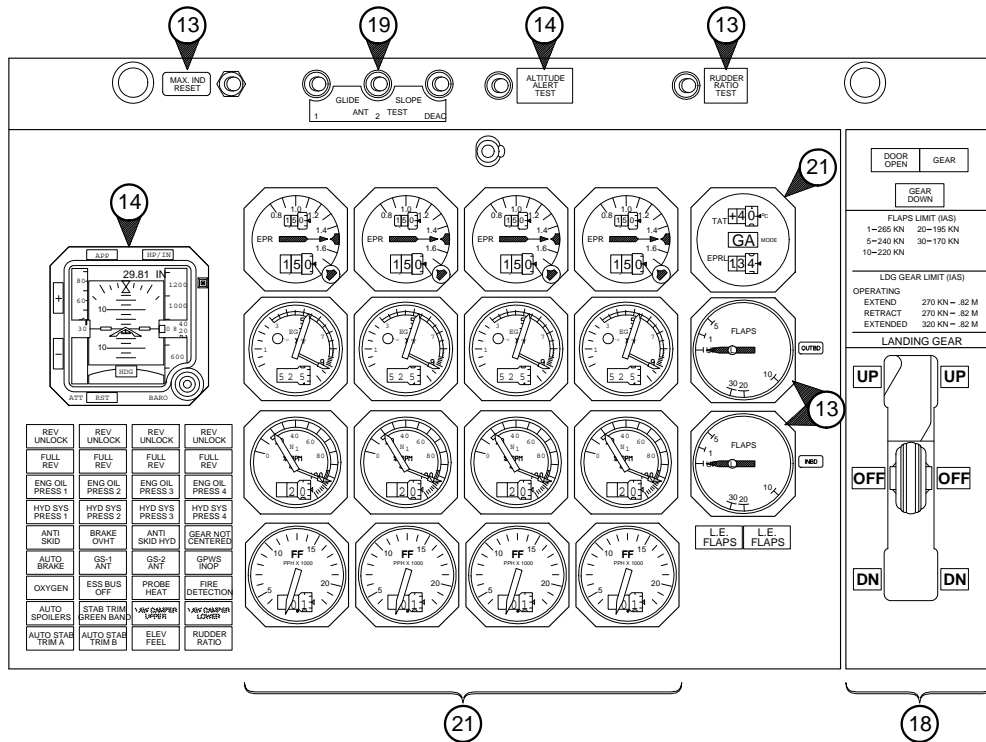

**PILOTS' CENTER INSTRUMENT PANEL**

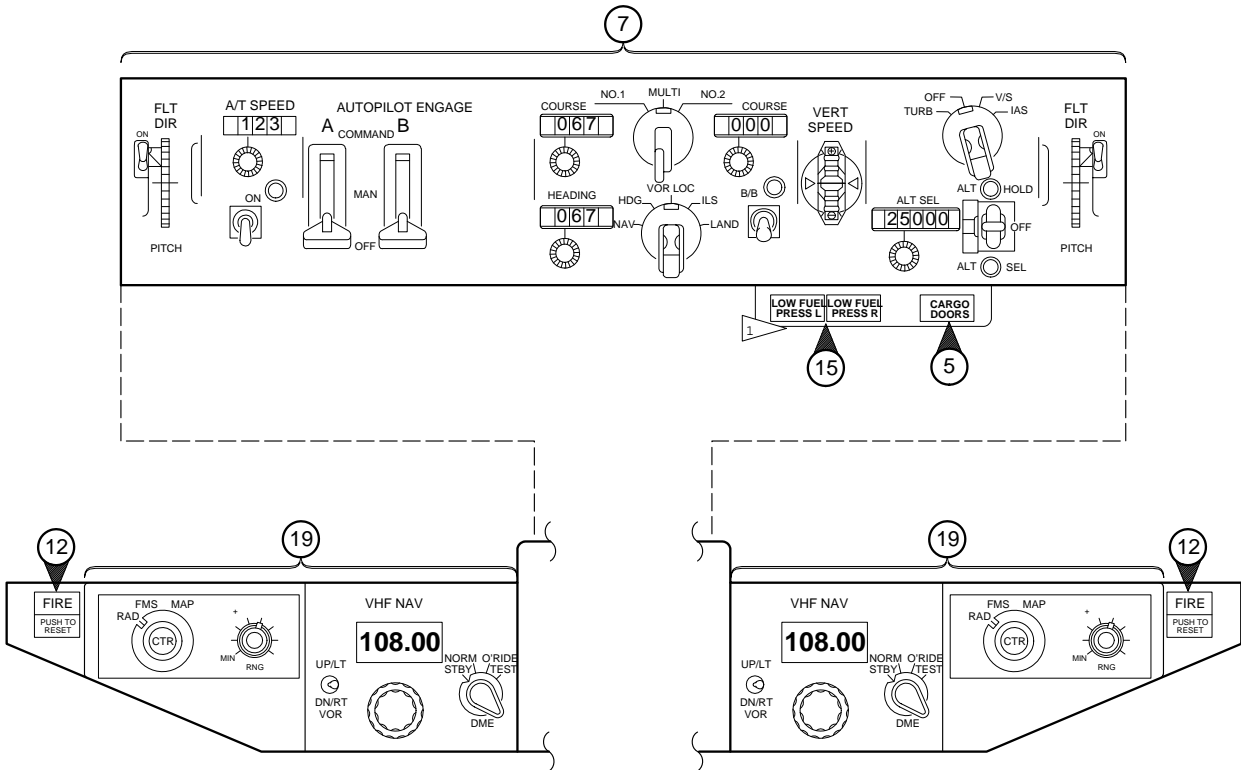

1 Low Fuel Pressure Lights - As installed by Boeing Service Bulletin 747-28A2288.

**PILOT'S LIGHTSHIELD**



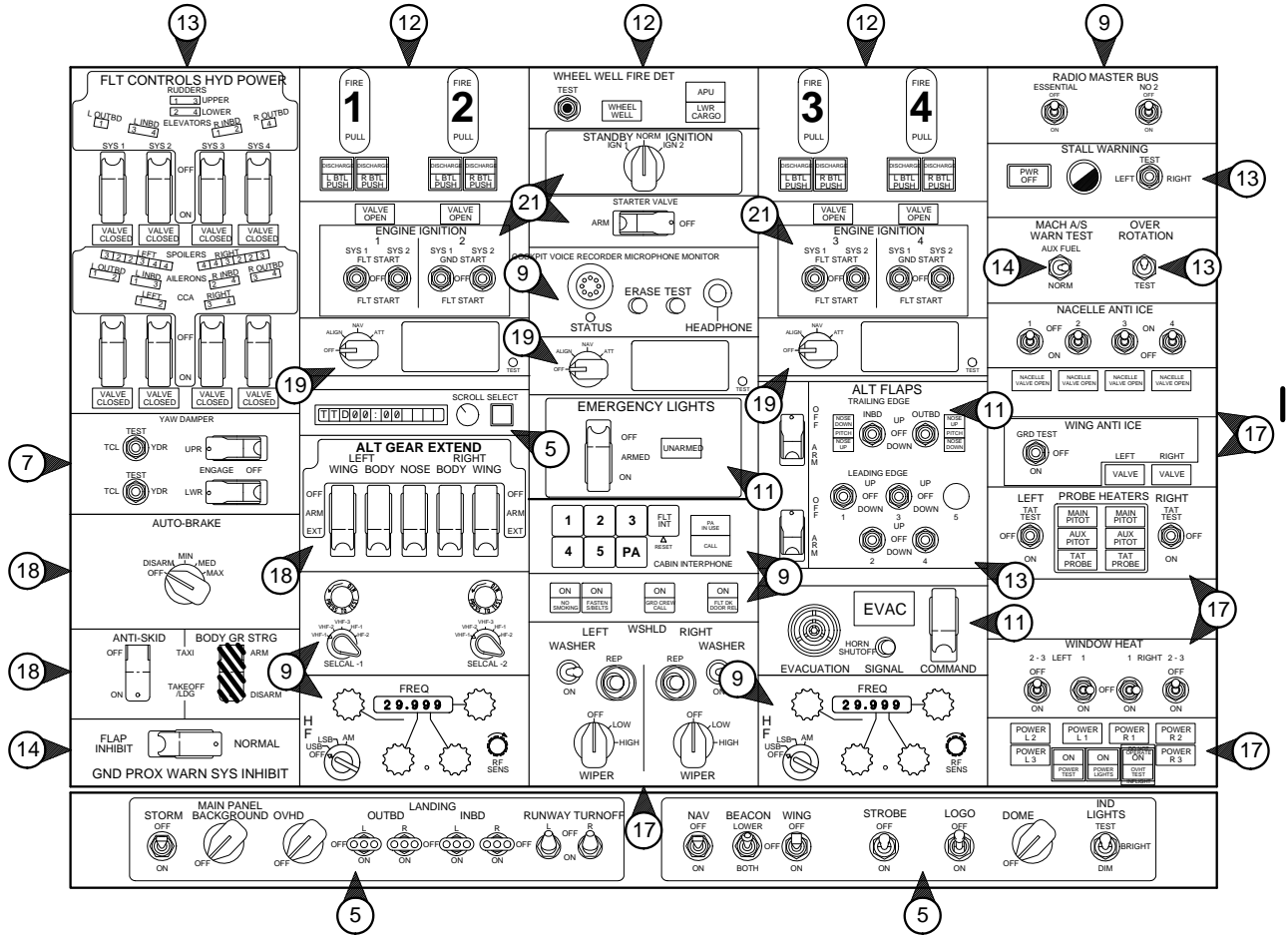

**PILOT'S OVERHEAD PANEL**

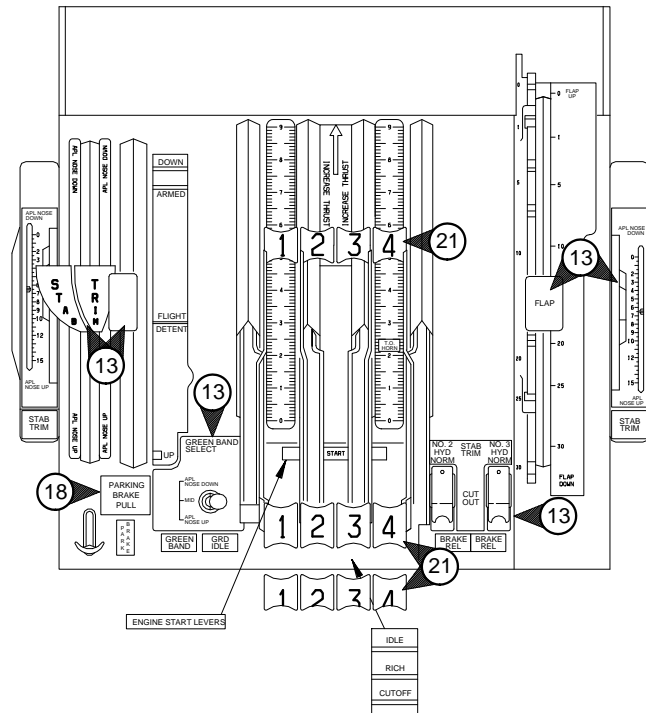
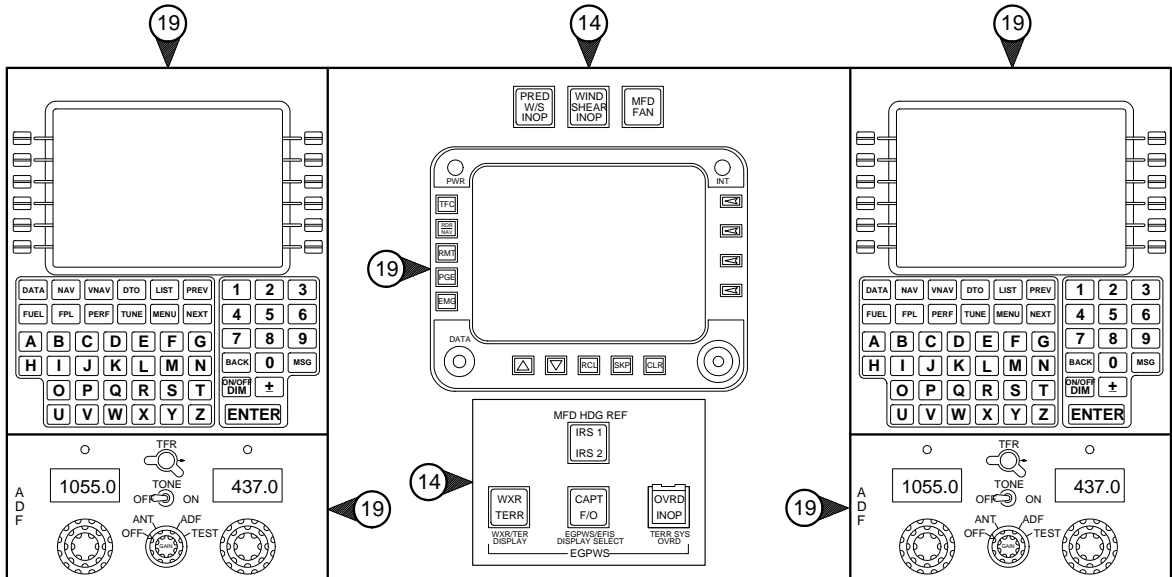

**PILOTS' CONTROL STAND (FWD)**

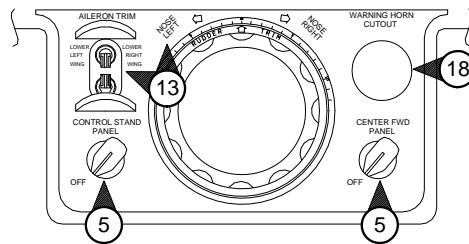
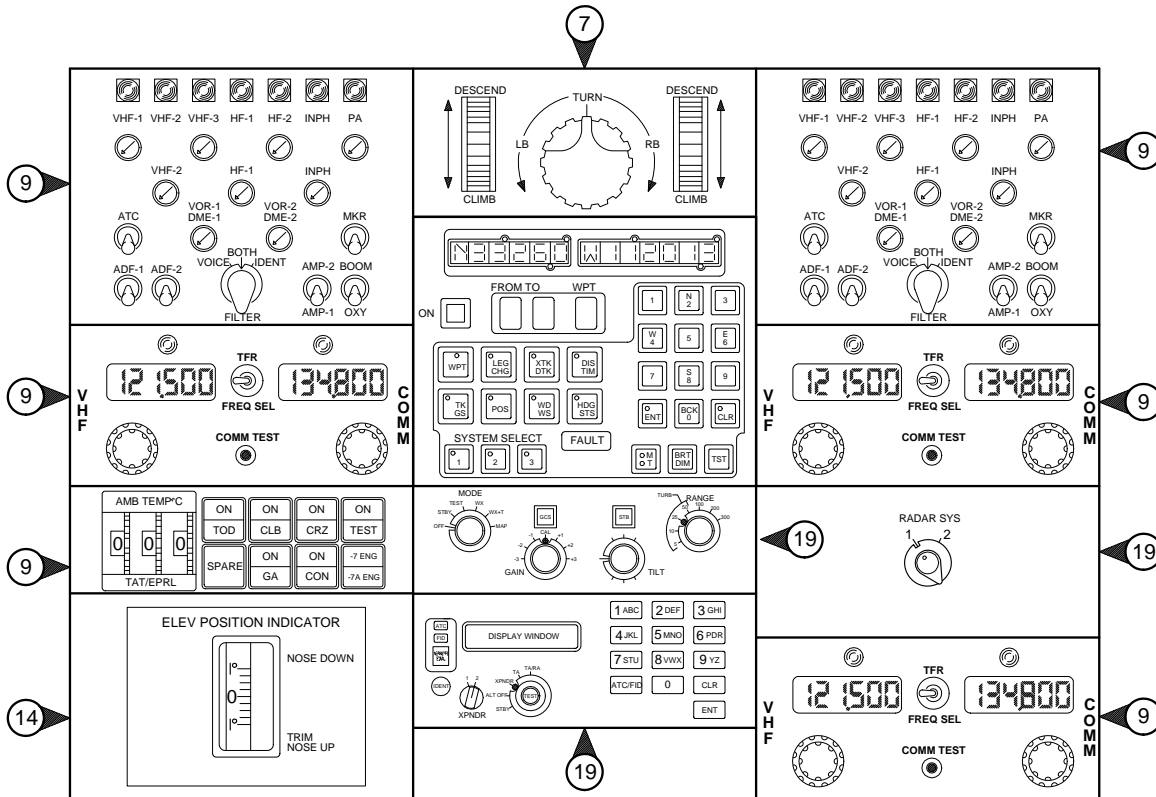

**PILOTS' CONTROL STAND (AFT)**

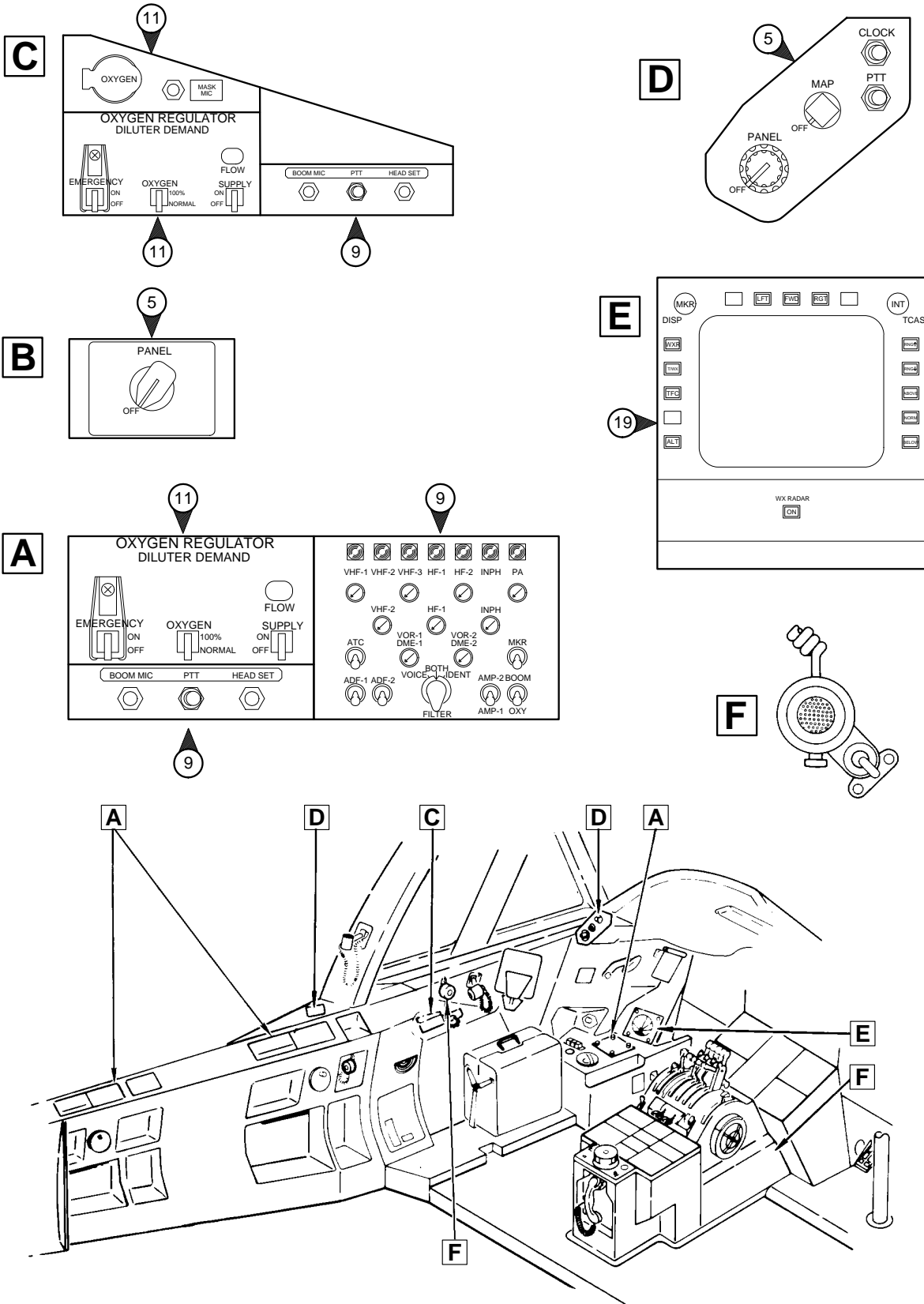

**CAPTAIN'S & FIRST OFFICER'S AUXILIARY PANELS**

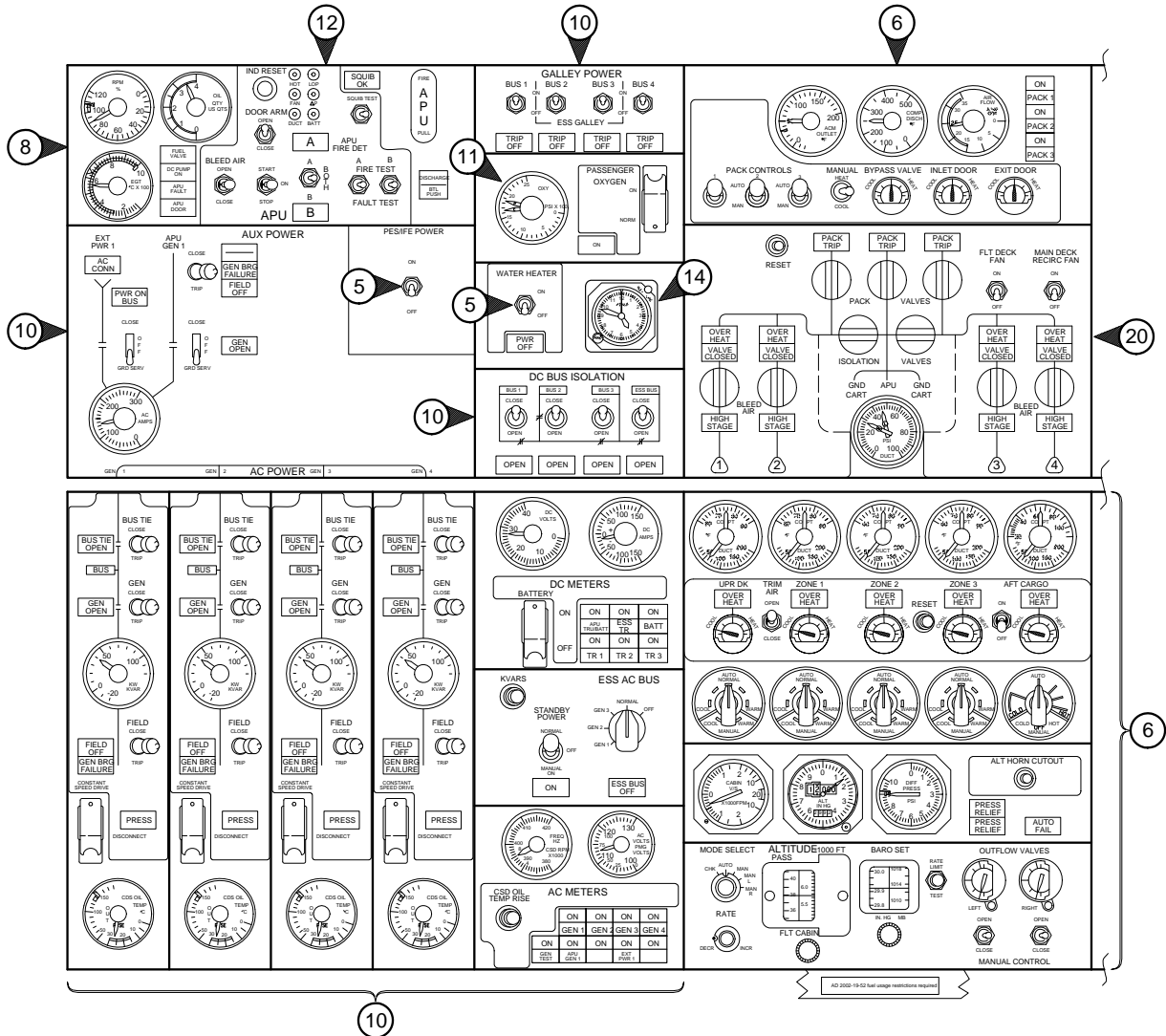

**FLIGHT ENGINEER'S INSTRUMENT PANEL - UPPER PANELS - LEFT**

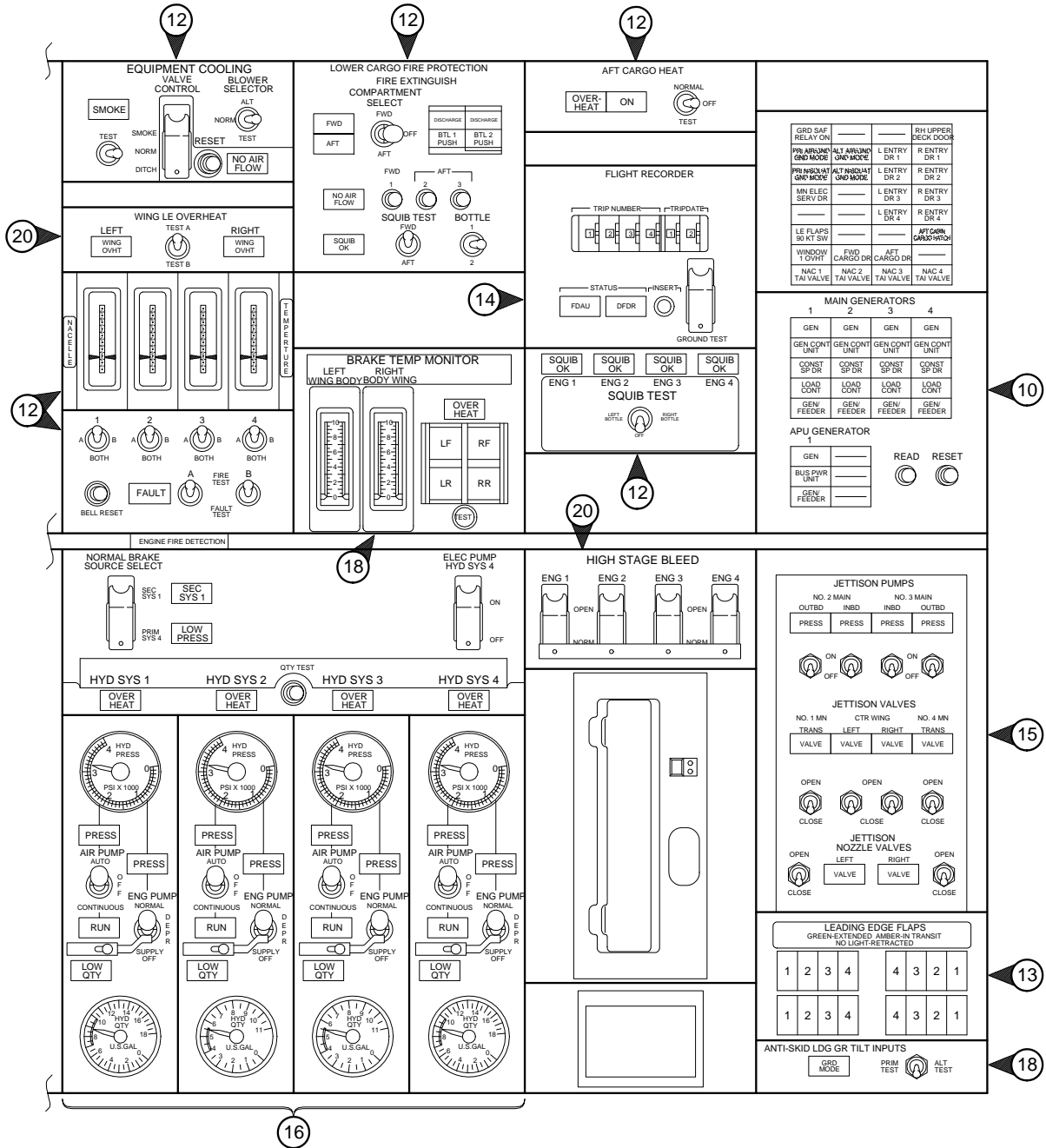

**FLIGHT ENGINEER'S INSTRUMENT PANEL - UPPER PANELS - RIGHT**

21

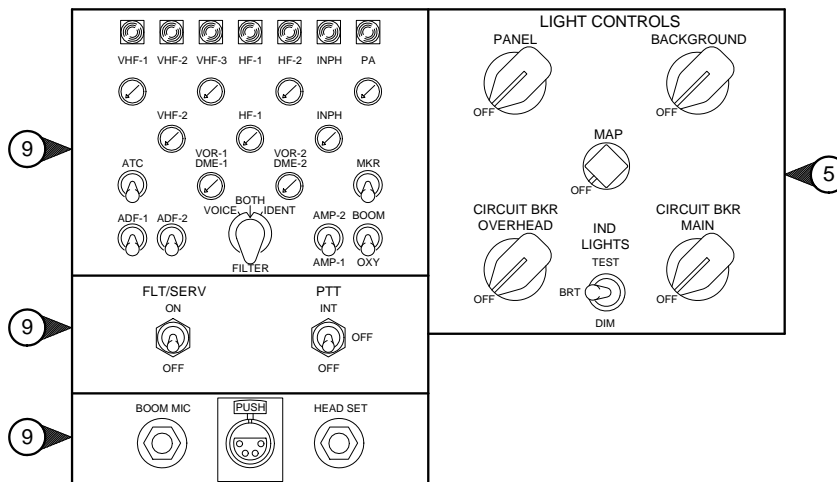
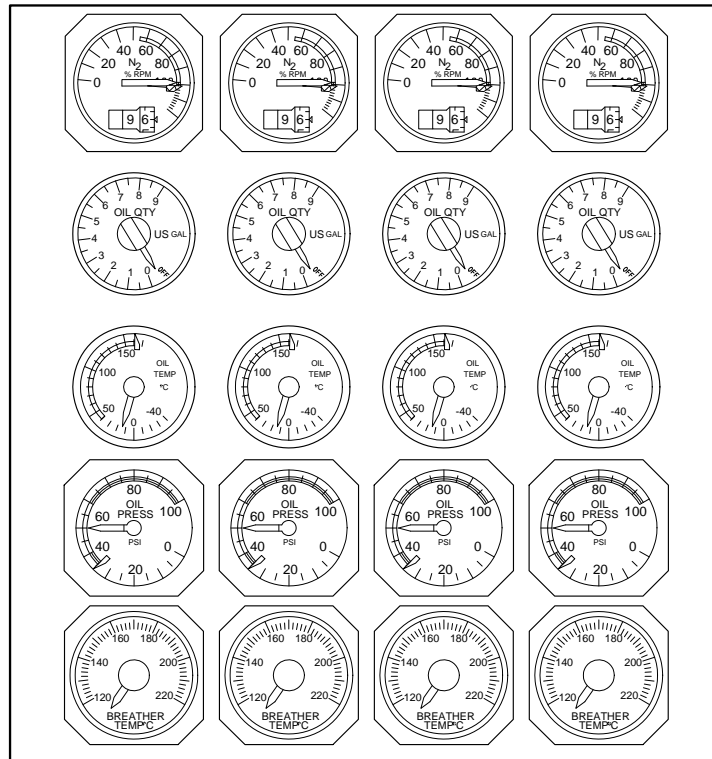

**FLIGHT ENGINEER'S INSTRUMENT PANEL  
(LOWER LEFT)**

Copyright © Boeing. Boeing Proprietary. May be subject to export restrictions under EAR. See title page for details.

15

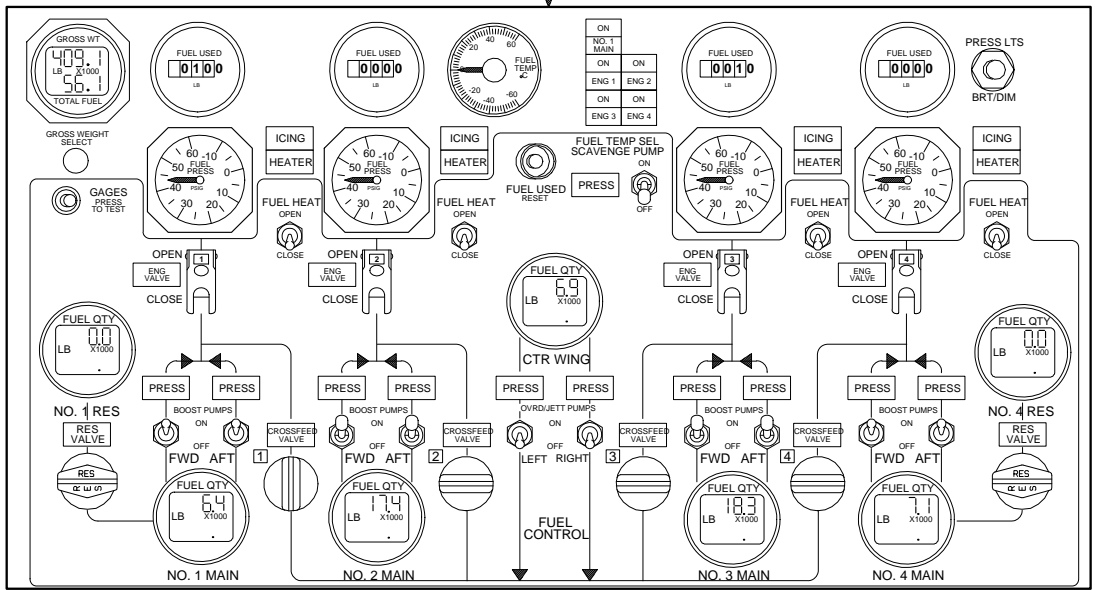

**FLIGHT ENGINEER'S FUEL PANEL**



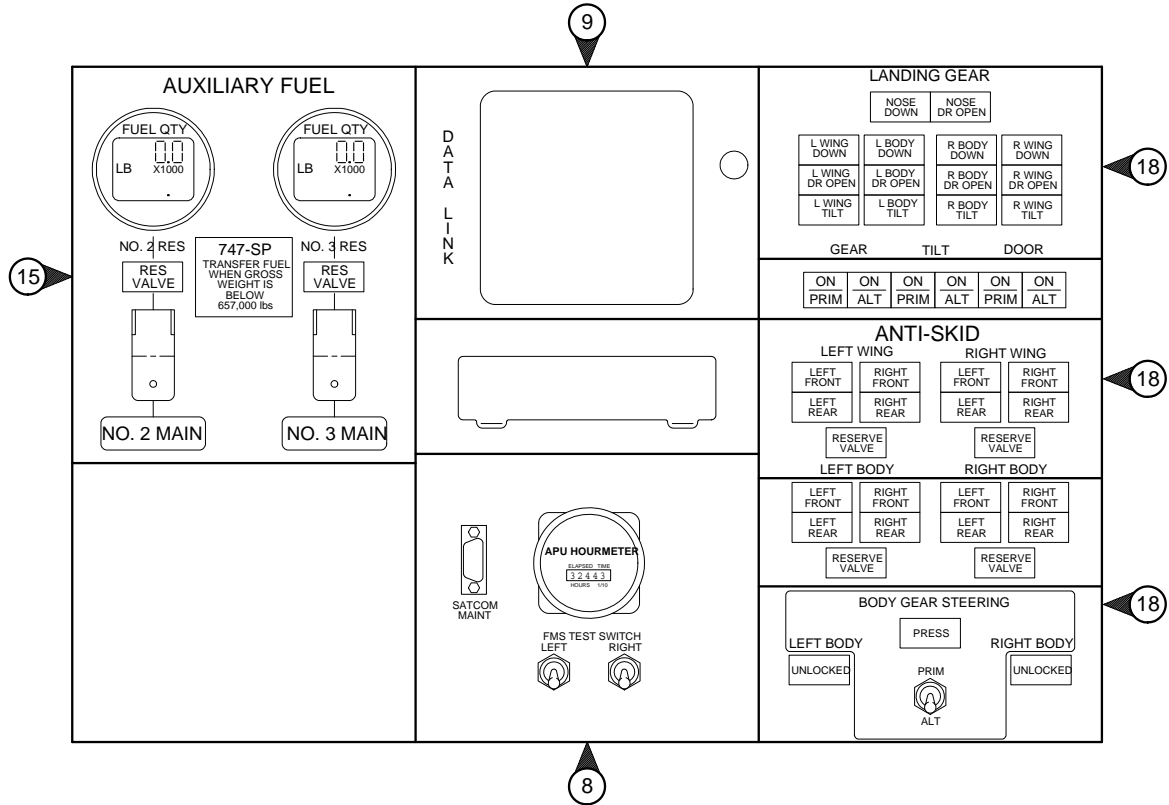

**FLIGHT ENGINEER'S INSTRUMENT PANEL - LOWER PANELS - RIGHT**