

## 1.1 INTRODUCTION

Fluid mechanics is that branch of science which deals with the behaviour of the fluids (liquids or gases) at rest as well as in motion. Thus this branch of science deals with the static, kinematics and dynamic aspects of fluids. The study of fluids at rest is called fluid statics. The study of fluids in motion, where pressure forces are not considered, is called fluid kinematics and if the pressure forces are also considered for the fluids in motion, that branch of science is called fluid dynamics.

## 1.2 PROPERTIES OF FLUIDS

1.2.1 Density or Mass Density. Density or mass density of a fluid is defined as the ratio of the mass of a fluid to its volume. Thus mass per unit volume of a fluid is called density. It is denoted by the symbol  $\rho$  (rho). The unit of mass density in SI unit is kg per cubic metre, i.e.  $\text{kg/m}^3$ . The density of liquids may be considered as constant while that of gases changes with the variation of pressure and temperature.

Mathematically, mass density is written as

$$\rho = \frac{\text{Mass of fluid}}{\text{Volume of fluid}}$$

The value of density of water is  $1 \text{ gm/cm}^3$  or  $1000 \text{ kg/m}^3$ .

1.2.2 Specific Weight or Weight Density. Specific weight or weight density of a fluid is the ratio between the weight of a fluid to its volume. Thus weight per unit volume of a fluid is called weight density and it is denoted by the symbol  $w$ .

Thus mathematically,  $w = \frac{\text{Weight of fluid}}{\text{Volume of fluid}} = \frac{(\text{Mass of fluid}) \times \text{Acceleration due to gravity}}{\text{Volume of fluid}}$

$$= \frac{\text{Mass of fluid} \times g}{\text{Volume of fluid}}$$

$$= \rho \times g$$

$$w = \rho g$$

$$\left\{ \frac{\text{Mass of fluid}}{\text{Volume of fluid}} = \rho \right\}$$



The value of specific weight or weight density ( $w$ ) for water is  $9.81 \times 1000$  Newton/m<sup>3</sup> in SI units.

**1.2.3 Specific Volume.** Specific volume of a fluid is defined as the volume of a fluid occupied by a unit mass or volume per unit mass of a fluid is called specific volume. Mathematically, it is expressed as

$$\text{Specific volume} = \frac{\text{Volume of fluid}}{\text{Mass of fluid}} = \frac{1}{\frac{\text{Mass of fluid}}{\text{Volume of fluid}}} = \frac{1}{\rho}$$

Thus specific volume is the reciprocal of mass density. It is expressed as m<sup>3</sup>/kg. It is commonly applied to gases.

**1.2.4 Specific Gravity.** Specific gravity is defined as the ratio of the weight density (or density) of a fluid to the weight density (or density) of a standard fluid. For liquids, the standard fluid is taken water and for gases, the standard fluid is taken air. Specific gravity is also called relative density. It is dimensionless quantity and is denoted by the symbol  $S$ .

$$\text{Mathematically, } S(\text{for liquids}) = \frac{\text{Weight density (density) of liquid}}{\text{Weight density (density) of water}}$$

$$S(\text{for gases}) = \frac{\text{Weight density (density) of gas}}{\text{Weight density (density) of air}}$$

$$\begin{aligned} \text{Thus weight density of a liquid} &= S \times \text{Weight density of water} \\ &= S \times 1000 \times 9.81 \text{ N/m}^3 \end{aligned}$$

$$\begin{aligned} \text{The density of a liquid} &= S \times \text{Density of water} \\ &= S \times 1000 \text{ kg/m}^3. \end{aligned} \quad \dots(1.1A)$$

If the specific gravity of a fluid is known, then the density of the fluid will be equal to specific gravity of fluid multiplied by the density of water. For example, the specific gravity of mercury is 13.6, hence density of mercury =  $13.6 \times 1000 = 13600$  kg/m<sup>3</sup>.

**Problem 1.1** Calculate the specific weight, density and specific gravity of one litre of a liquid which weighs 7 N.

**Solution.** Given :

$$\text{Volume} = 1 \text{ litre} = \frac{1}{1000} \text{ m}^3 \quad \left( \because 1 \text{ litre} = \frac{1}{1000} \text{ m}^3 \text{ or } 1 \text{ litre} = 1000 \text{ cm}^3 \right)$$

$$\text{Weight} = 7 \text{ N}$$

$$(i) \text{ Specific weight } (w) = \frac{\text{Weight}}{\text{Volume}} = \frac{7 \text{ N}}{\left(\frac{1}{1000}\right) \text{ m}^3} = 7000 \text{ N/m}^3. \text{ Ans.}$$

$$(ii) \text{ Density } (\rho) = \frac{w}{g} = \frac{7000}{9.81} \text{ kg/m}^3 = 713.5 \text{ kg/m}^3. \text{ Ans.}$$

$$\begin{aligned} (iii) \text{ Specific gravity} &= \frac{\text{Density of liquid}}{\text{Density of water}} = \frac{713.5}{1000} \quad \left\{ \because \text{Density of water} = 1000 \text{ kg/m}^3 \right\} \\ &= 0.7135. \text{ Ans.} \end{aligned}$$



**Problem 1.2** Calculate the density, specific weight and weight of one litre of petrol of specific gravity = 0.7

**Solution.** Given : Volume = 1 litre =  $1 \times 1000 \text{ cm}^3 = \frac{1000}{10^6} \text{ m}^3 = 0.001 \text{ m}^3$

Sp. gravity  $S = 0.7$

(i) Density ( $\rho$ )

Using equation (1.1A),

Density ( $\rho$ )

$$= S \times 1000 \text{ kg/m}^3 = 0.7 \times 1000 = 700 \text{ kg/m}^3. \text{ Ans.}$$

(ii) Specific weight ( $w$ )

Using equation (1.1),

$$w = \rho \times g = 700 \times 9.81 \text{ N/m}^3 = 6867 \text{ N/m}^3. \text{ Ans.}$$

(iii) Weight ( $W$ )

We know that specific weight =  $\frac{\text{Weight}}{\text{Volume}}$

$$\text{or } w = \frac{W}{0.001} \text{ or } 6867 = \frac{W}{0.001}$$

$$\therefore W = 6867 \times 0.001 = 6.867 \text{ N. Ans.}$$

### ► 1.3 VISCOSITY

Viscosity is defined as the property of a fluid which offers resistance to the movement of one layer of fluid over another adjacent layer of the fluid. When two layers of a fluid, a distance 'dy' apart, move one over the other at different velocities, say u and u + du as shown in Fig. 1.1, the viscosity together with relative velocity causes a shear stress acting between the fluid layers.

The top layer causes a shear stress on the adjacent lower layer while the lower layer causes a shear stress on the adjacent top layer. This shear stress is proportional to the rate of change of velocity with respect to y. It is denoted by symbol  $\tau$  (Tau).

Mathematically,

$$\tau \propto \frac{du}{dy}$$

or

$$\tau = \mu \frac{du}{dy} \quad \dots(1.2)$$

where  $\mu$  (called mu) is the constant of proportionality and is known as the co-efficient of dynamic viscosity or only viscosity.  $\frac{du}{dy}$  represents the rate of shear strain or rate of shear deformation or velocity gradient.

$$\text{From equation (1.2), we have } \mu = \frac{\tau}{\left(\frac{du}{dy}\right)} \quad \dots(1.3)$$

Thus viscosity is also defined as the shear stress required to produce unit rate of shear strain.

**1.3.1 Units of Viscosity.** The units of viscosity is obtained by putting the dimensions of the quantities in equation (1.3)

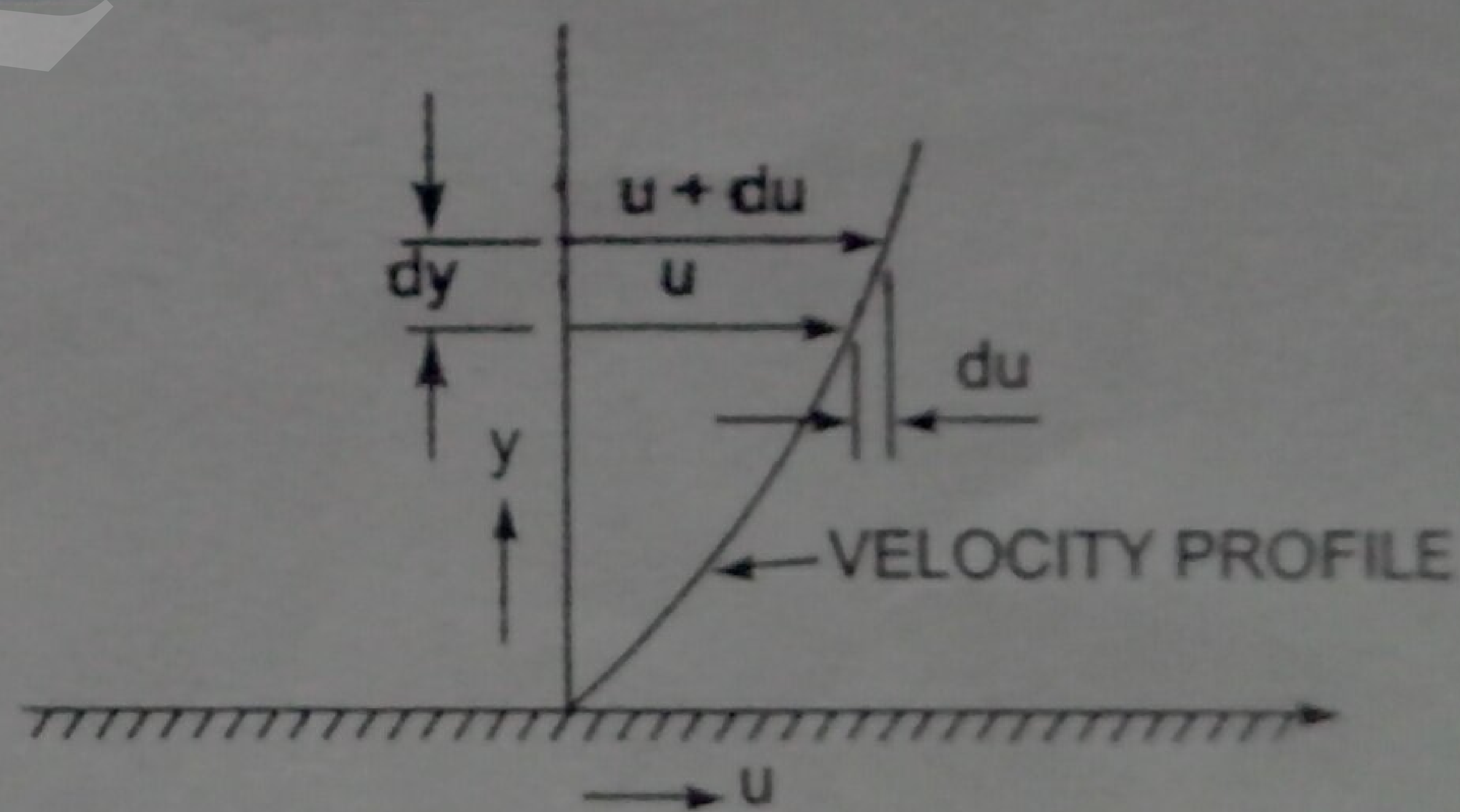

Fig. 1.1 Velocity variation near a solid boundary.



$$\mu = \frac{\text{Shear stress}}{\text{Change of velocity}} = \frac{\text{Force/Area}}{\left(\frac{\text{Length}}{\text{Time}}\right) \times \frac{1}{\text{Length}}}$$

$$= \frac{\text{Force}/(\text{Length})^2}{\frac{1}{\text{Time}}} = \frac{\text{Force} \times \text{Time}}{(\text{Length})^2}$$

In MKS system, force is represented by kgf and length by metre (m), in CGS system, force is represented by dyne and length by cm and in SI system force is represented by Newton (N) and length by metre (m).

$$\therefore \text{MKS unit of viscosity} = \frac{\text{kgf-sec}}{\text{m}^2}$$

$$\text{CGS unit of viscosity} = \frac{\text{dyne-sec}}{\text{cm}^2}$$

In the above expression  $\text{N/m}^2$  is also known as Pascal which is represented by Pa. Hence  $\text{N/m}^2 = \text{Pa} = \text{Pascal}$

$$\therefore \text{SI unit of viscosity} = \text{Ns/m}^2 = \text{Pa s.}$$

$$\text{SI unit of viscosity} = \frac{\text{Newton-sec}}{\text{m}^2} = \frac{\text{Ns}}{\text{m}^2}$$

The unit of viscosity in CGS is also called Poise which is equal to  $\frac{\text{dyne-sec}}{\text{cm}^2}$ .

The numerical conversion of the unit of viscosity from MKS unit to CGS unit is given below :

$$\frac{\text{one kgf-sec}}{\text{m}^2} = \frac{9.81 \text{ N-sec}}{\text{m}^2} \quad \{ \because 1 \text{ kgf} = 9.81 \text{ Newton} \}$$

But one Newton = one kg (mass)  $\times$  one  $\left(\frac{\text{m}}{\text{sec}^2}\right)$  (acceleration)

$$= \frac{(1000 \text{ gm}) \times (100 \text{ cm})}{\text{sec}^2} = 1000 \times 100 \frac{\text{gm-cm}}{\text{sec}^2}$$

$$= 1000 \times 100 \text{ dyne} \quad \left\{ \because \text{dyne} = \text{gm} \times \frac{\text{cm}}{\text{sec}^2} \right\}$$

$$\therefore \frac{\text{one kgf-sec}}{\text{m}^2} = 9.81 \times 100000 \frac{\text{dyne-sec}}{\text{cm}^2} = 9.81 \times 100000 \frac{\text{dyne-sec}}{100 \times 100 \times \text{cm}^2}$$

$$= 98.1 \frac{\text{dyne-sec}}{\text{cm}^2} = 98.1 \text{ poise} \quad \left\{ \because \frac{\text{dyne-sec}}{\text{cm}^2} = \text{Poise} \right\}$$

Thus for solving numerical problems, if viscosity is given in poise, it must be divided by 98.1 to get its equivalent numerical value in MKS.

$$\text{But } \frac{\text{one kgf-sec}}{\text{m}^2} = \frac{9.81 \text{ Ns}}{\text{m}^2} = 98.1 \text{ poise}$$

$$\therefore \frac{\text{one Ns}}{\text{m}^2} = \frac{98.1}{9.81} \text{ poise} = 10 \text{ poise} \quad \text{or} \quad \boxed{\text{One poise} = \frac{1}{10} \frac{\text{Ns}}{\text{m}^2}}$$



Alternate Method, One poise =  $\frac{\text{dyne} \times \text{s}}{\text{cm}^2} = \left( \frac{1 \text{ gm} \times 1 \text{ cm}}{\text{s}^2} \right) \times \frac{\text{s}}{\text{cm}^2}$

But dyne =  $1 \text{ gm} \times \frac{1 \text{ cm}}{\text{s}^2}$

∴ One poise =  $\frac{1 \text{ gm}}{\text{s cm}} = \frac{1000 \text{ kg}}{\text{s} \frac{1}{100} \text{ m}}$

=  $\frac{1}{1000} \times 100 \frac{\text{kg}}{\text{sm}} = \frac{1}{10} \frac{\text{kg}}{\text{sm}}$  or  $1 \frac{\text{kg}}{\text{sm}} = 10 \text{ poise.}$

Note. (i) In SI units second is represented by 's' and not by 'sec'.

(ii) If viscosity is given in poise, it must be divided by 10 to get its equivalent numerical value in SI units.

Sometimes a unit of viscosity as centipoise is used where

$$1 \text{ centipoise} = \frac{1}{100} \text{ poise} \quad \text{or} \quad 1 \text{ cP} = \frac{1}{100} \text{ P} \quad [\text{cP} = \text{Centipoise, P} = \text{Poise}]$$

The viscosity of water at 20°C is 0.01 poise or 1.0 centipoise.

**1.3.2 Kinematic Viscosity.** It is defined as the ratio between the dynamic viscosity and density of fluid. It is denoted by the Greek symbol ( $\nu$ ) called 'nu'. Thus, mathematically,

$$\nu = \frac{\text{Viscosity}}{\text{Density}} = \frac{\mu}{\rho} \quad \dots(1.4)$$

The units of kinematic viscosity is obtained as

$$\nu = \frac{\text{Units of } \mu}{\text{Units of } \rho} = \frac{\text{Force} \times \text{Time}}{(\text{Length})^2 \times \frac{\text{Mass}}{(\text{Length})^3}} = \frac{\text{Force} \times \text{Time}}{\text{Mass} \times \text{Length}}$$

$$= \frac{\text{Mass} \times \frac{\text{Length}}{(\text{Time})^2} \times \text{Time}}{\left( \frac{\text{Mass}}{\text{Length}} \right) \times \text{Length}}$$

$$\left\{ \begin{aligned} \because \text{Force} &= \text{Mass} \times \text{Acc.} \\ &= \text{Mass} \times \frac{\text{Length}}{\text{Time}^2} \end{aligned} \right\}$$

$$= \frac{(\text{Length})^2}{\text{Time}}$$

In MKS and SI, the unit of kinematic viscosity is metre<sup>2</sup>/sec or m<sup>2</sup>/sec while in CGS units it is written as cm<sup>2</sup>/s. In CGS units, kinematic viscosity is also known as stoke.

Thus, one stoke = cm<sup>2</sup>/s =  $\left( \frac{1}{100} \right)^2 \text{ m}^2/\text{s} = 10^{-4} \text{ m}^2/\text{s}$

Centistoke means =  $\frac{1}{100}$  stoke.

**1.3.3 Newton's Law of Viscosity.** It states that the shear stress ( $\tau$ ) on a fluid element layer is directly proportional to the rate of shear strain. The constant of proportionality is called the coefficient of viscosity. Mathematically, it is expressed as given by equation (1.2) or as

$$\tau = \mu \frac{du}{dy}$$



Fluids which obey the above relation are known as Newtonian fluids and the fluids which do not obey the above relation are called Non-Newtonian fluids.

**1.3.4 Variation of Viscosity with Temperature.** Temperature affects the viscosity. The viscosity of liquids decreases with the increase of temperature while the viscosity of gases increases with the increase of temperature. This is due to reason that the viscous forces in a fluid are due to cohesive forces and molecular momentum transfer. In liquids, the cohesive forces predominates the molecular momentum transfer, due to closely packed molecules and with the increase in temperature, the cohesive forces decreases with the result of decreasing viscosity. But in case of gases the cohesive forces are small and molecular momentum transfer predominates. With the increase in temperature, molecular momentum transfer increases and hence viscosity increases. The relation between viscosity and temperature for liquids and gases are:

$$(i) \text{ For liquids, } \mu = \mu_0 \left( \frac{1}{1 + \alpha t + \beta t^2} \right) \quad \dots(1.4A)$$

where  $\mu$  = Viscosity of liquid at  $t^\circ\text{C}$ , in poise  
 $\mu_0$  = Viscosity of liquid at  $0^\circ\text{C}$ , in poise  
 $\alpha, \beta$  = Constants for the liquid

For water,  $\mu_0 = 1.79 \times 10^{-3}$  poise,  $\alpha = 0.03368$  and  $\beta = 0.000221$ .

Equation (1.4A) shows that with the increase of temperature, the viscosity decreases.

$$(ii) \text{ For a gas, } \mu = \mu_0 + \alpha t - \beta t^2 \quad \dots(1.4B)$$

where for air  $\mu_0 = 0.000017$ ,  $\alpha = 0.000000056$ ,  $\beta = 0.1189 \times 10^{-9}$ .

Equation (1.4B) shows that with the increase of temperature, the viscosity increases.

**1.3.5 Types of Fluids.** The fluids may be classified into the following five types :

1. Ideal fluid,
2. Real fluid,
3. Newtonian fluid,
4. Non-Newtonian fluid, and
5. Ideal plastic fluid.

1. **Ideal Fluid.** A fluid, which is incompressible and is having no viscosity, is known as an ideal fluid. Ideal fluid is only an imaginary fluid as all the fluids, which exist, have some viscosity.

2. **Real Fluid.** A fluid, which possesses viscosity, is known as real fluid. All the fluids, in actual practice, are real fluids.

3. **Newtonian Fluid.** A real fluid, in which the shear stress is directly proportional to the rate of shear strain (or velocity gradient), is known as a Newtonian fluid.

4. **Non-Newtonian Fluid.** A real fluid, in which the shear stress is not proportional to the rate of shear strain (or velocity gradient), known as a Non-Newtonian fluid.

5. **Ideal Plastic Fluid.** A fluid, in which shear stress is more than the yield value and shear stress is proportional to the rate of shear strain (or velocity gradient), is known as ideal plastic fluid.

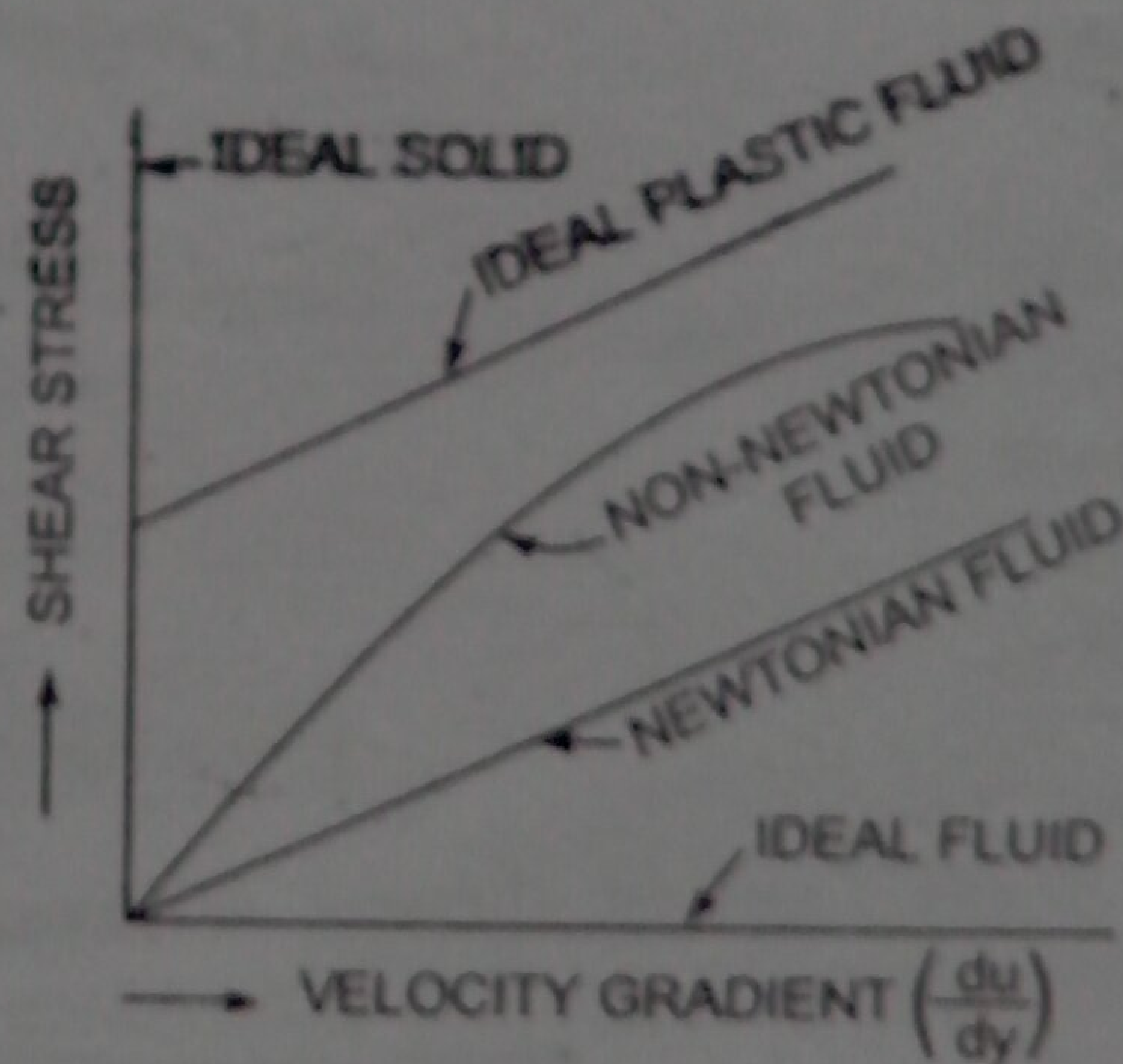

Fig. 1.2 Types of fluids.

**Problem 1.3** If the velocity distribution over a plate is given by  $u = \frac{2}{3} y - y^2$  in which  $u$  is the velocity in metre per second at a distance  $y$  metre above the plate, determine the shear stress at  $y = 0$  and  $y = 0.15$  m. Take dynamic viscosity of fluid as 8.63 poises.



Solution. Given :

$$u = \frac{2}{3}y - y^2 \quad \therefore \frac{du}{dy} = \frac{2}{3} - 2y$$

$$\left(\frac{du}{dy}\right)_{\text{at } y=0} \quad \text{or} \quad \left(\frac{du}{dy}\right)_{y=0} = \frac{2}{3} - 2(0) = \frac{2}{3} = 0.667$$

Also  $\left(\frac{du}{dy}\right)_{\text{at } y=0.15} \quad \text{or} \quad \left(\frac{du}{dy}\right)_{y=0.15} = \frac{2}{3} - 2 \times .15 = .667 - .30 = 0.367$

Value of  $\mu = 8.63 \text{ poise} = \frac{8.63}{10} \text{ SI units} = 0.863 \text{ N s/m}^2$

Now shear stress is given by equation (1.2) as  $\tau = \mu \frac{du}{dy}$ .

(i) Shear stress at  $y = 0$  is given by

$$\tau_0 = \mu \left(\frac{du}{dy}\right)_{y=0} = 0.863 \times 0.667 = 0.5756 \text{ N/m}^2. \text{ Ans.}$$

(ii) Shear stress at  $y = 0.15 \text{ m}$  is given by

$$(\tau)_{y=0.15} = \mu \left(\frac{du}{dy}\right)_{y=0.15} = 0.863 \times 0.367 = 0.3167 \text{ N/m}^2. \text{ Ans.}$$

**Problem 1.4** A plate 0.025 mm distant from a fixed plate, moves at 60 cm/s and requires a force of 2 N per unit area i.e., 2 N/m<sup>2</sup> to maintain this speed. Determine the fluid viscosity between the plates.

Solution. Given :

Distance between plates,  $dy = .025 \text{ mm}$   
 $= .025 \times 10^{-3} \text{ m}$

Velocity of upper plate,  $u = 60 \text{ cm/s} = 0.6 \text{ m/s}$

Force on upper plate,  $F = 2.0 \frac{\text{N}}{\text{m}^2}$

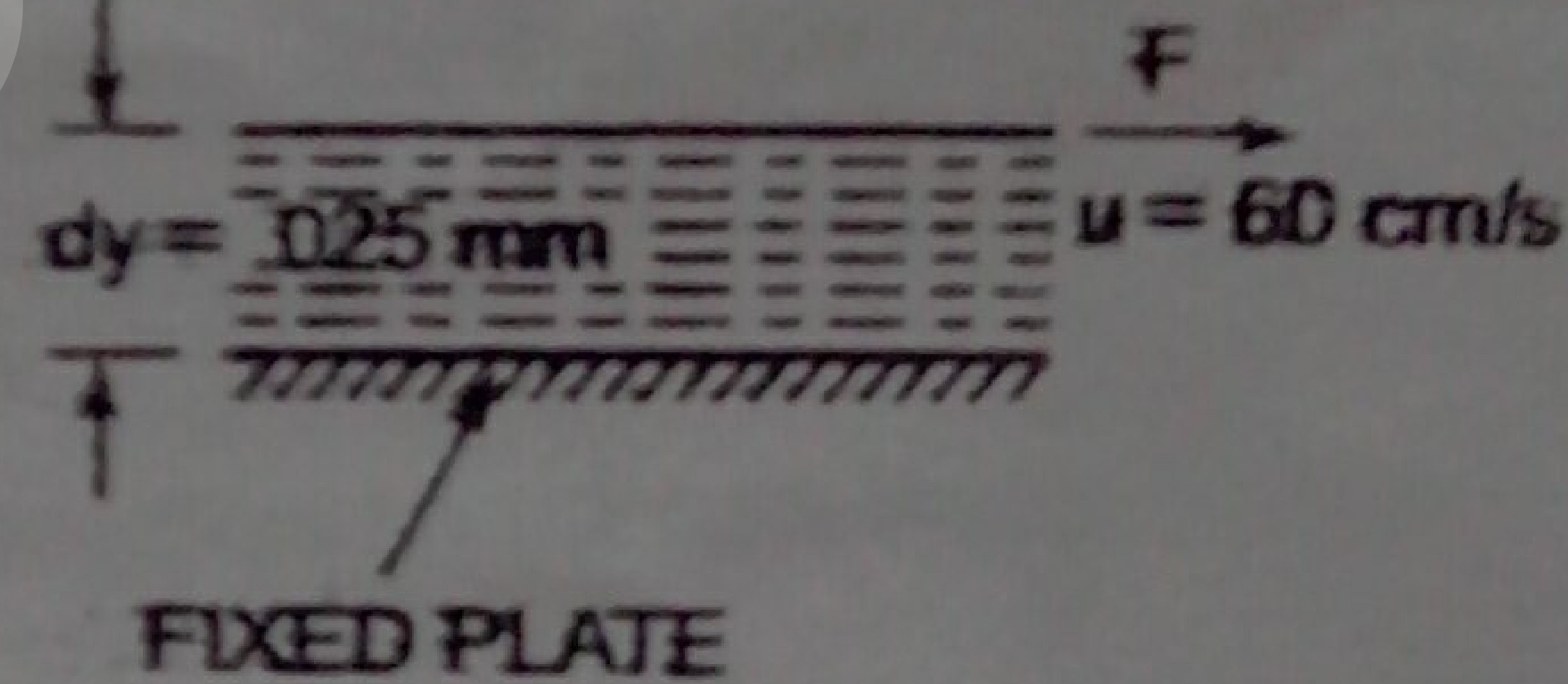

Fig. 1.3

This is the value of shear stress i.e.,  $\tau$

Let the fluid viscosity between the plates is  $\mu$ .

Using the equation (1.2), we have  $\tau = \mu \frac{du}{dy}$ .

where  $du = \text{Change of velocity} = u - 0 = u = 0.60 \text{ m/s}$

$dy = \text{Change of distance} = .025 \times 10^{-3} \text{ m}$

$$\tau = \text{Force per unit area} = 2.0 \frac{\text{N}}{\text{m}^2}$$

$$\therefore 2.0 = \mu \frac{0.60}{.025 \times 10^{-3}} \quad \therefore \mu = \frac{2.0 \times .025 \times 10^{-3}}{0.60} = 8.33 \times 10^{-5} \frac{\text{Ns}}{\text{m}^2}$$

$$= 8.33 \times 10^{-5} \times 10 \text{ poise} = 8.33 \times 10^{-4} \text{ poise. Ans.}$$

**Problem 1.5** A flat plate of area  $1.5 \times 10^6 \text{ mm}^2$  is pulled with a speed of 0.4 m/s relative to another plate located at a distance of 0.15 mm from it. Find the force and power required to maintain this speed, if the fluid separating them is having viscosity as 1 poise.



**Solution.** Given :

Area of the plate,  $A = 1.5 \times 10^6 \text{ mm}^2 = 1.5 \text{ m}^2$

Speed of plate relative to another plate,  $du = 0.4 \text{ m/s}$

Distance between the plates,  $dy = 0.15 \text{ mm} = 0.15 \times 10^{-3} \text{ m}$

Viscosity  $\mu = 1 \text{ poise} = \frac{1}{10} \frac{\text{Ns}}{\text{m}^2}$

Using equation (1.2) we have  $\tau = \mu \frac{du}{dy} = \frac{1}{10} \times \frac{0.4}{.15 \times 10^{-3}} = 266.66 \frac{\text{N}}{\text{m}^2}$

(i)  $\therefore$  Shear force,  $F = \tau \times \text{area} = 266.66 \times 1.5 = 400 \text{ N. Ans.}$

(ii) Power\* required to move the plate at the speed 0.4 m/sec

$= F \times u = 400 \times 0.4 = 160 \text{ W. Ans.}$

**Problem 1.6** Determine the intensity of shear of an oil having viscosity = 1 poise. The oil is used for lubricating the clearance between a shaft of diameter 10 cm and its journal bearing. The clearance is 1.5 mm and the shaft rotates at 150 r.p.m.

**Solution.** Given :  $\mu = 1 \text{ poise} = \frac{1}{10} \frac{\text{Ns}}{\text{m}^2}$

Dia. of shaft,  $D = 10 \text{ cm} = 0.1 \text{ m}$

Distance between shaft and journal bearing,  
 $dy = 1.5 \text{ mm} = 1.5 \times 10^{-3} \text{ m}$

Speed of shaft,  $N = 150 \text{ r.p.m.}$

Tangential speed of shaft is given by

$$u = \frac{\pi DN}{60} = \frac{\pi \times 0.1 \times 150}{60} = 0.785 \text{ m/s}$$

Using equation (1.2),  $\tau = \mu \frac{du}{dy}$

where  $du =$  change of velocity between shaft and bearing  $= u - 0 = u$

$$= \frac{1}{10} \times \frac{0.785}{1.5 \times 10^{-3}} = 52.33 \text{ N/m}^2. \text{ Ans.}$$

**Problem 1.7** Calculate the dynamic viscosity of an oil, which is used for lubrication between a square plate of size 0.8 m  $\times$  0.8 m and an inclined plane with angle of inclination  $30^\circ$  as shown in Fig. 1.4. The weight of the square plate is 300 N and it slides down the inclined plane with a uniform velocity of 0.3 m/s. The thickness of oil film is 1.5 mm.

**Solution.** Given :

Area of plate,  $A = 0.8 \times 0.8 = 0.64 \text{ m}^2$

Angle of plane,  $\theta = 30^\circ$

Weight of plate,  $W = 300 \text{ N}$

Velocity of plate,  $u = 0.3 \text{ m/s}$

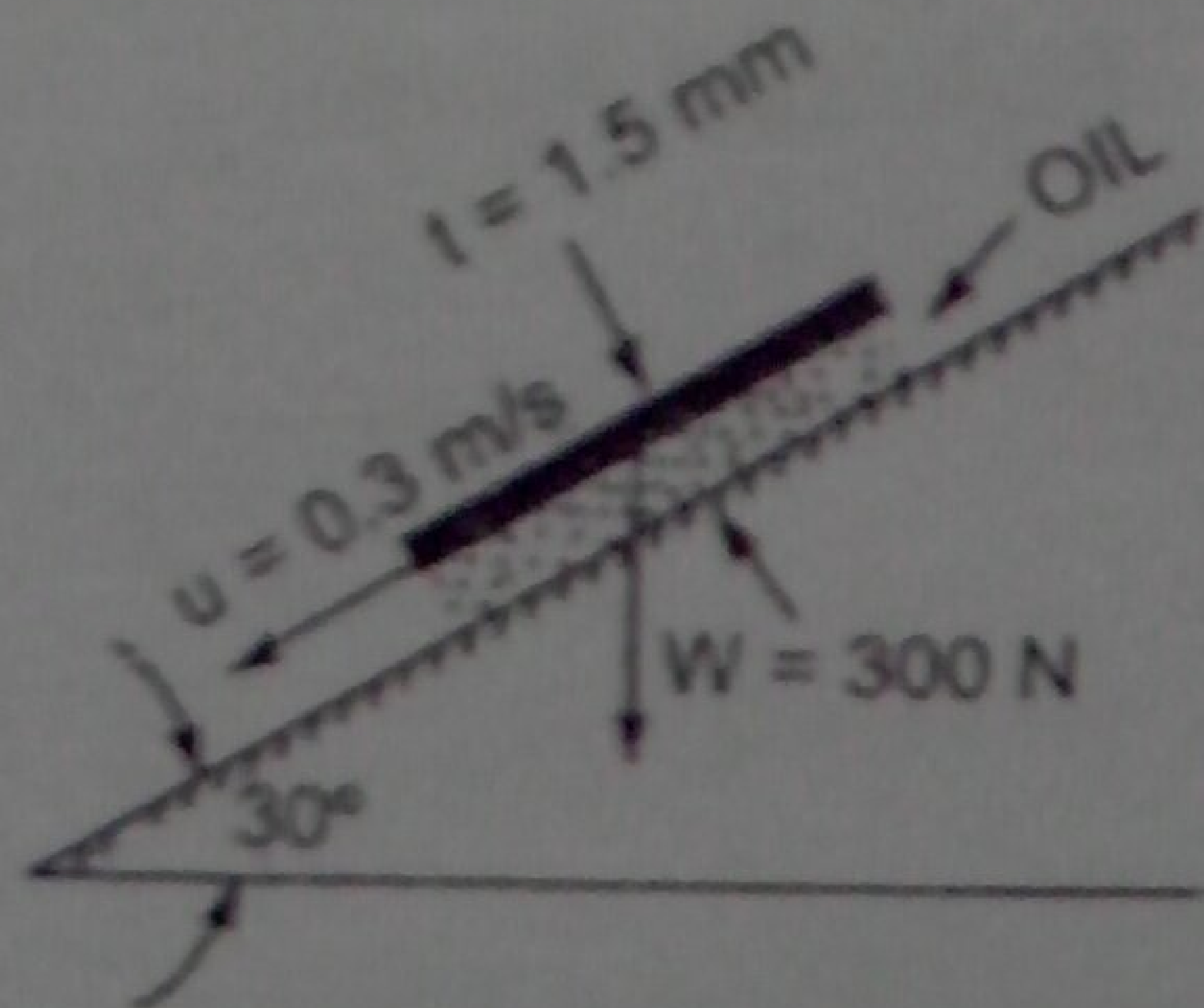

Fig. 1.4

\*  $\text{Power} = F \times u \text{ N m/s} = F \times u \text{ W} (\because \text{Nm/s} = \text{Watt})$

*Handwritten notes:*  
0.3 x 300 = 90  
90 / 0.3 = 300  
300 / 0.64 = 468.75  
468.75 / 0.3 = 1562.5



Thickness of oil film,  $t = dy = 1.5 \text{ mm} = 1.5 \times 10^{-3} \text{ m}$

Let the viscosity of fluid between plate and inclined plane is  $\mu$ .

Component of weight  $W$ , along the plane  $= W \cos 60^\circ = 300 \cos 60^\circ = 150 \text{ N}$

Thus the shear force,  $F$ , on the bottom surface of the plate  $= 150 \text{ N}$

and shear stress, 
$$\tau = \frac{F}{\text{Area}} = \frac{150}{0.64} \text{ N/m}^2$$

Now using equation (1.2), we have

$$\tau = \mu \frac{du}{dy}$$

where  $du = \text{change of velocity} = u - 0 = u = 0.3 \text{ m/s}$

$$dy = t = 1.5 \times 10^{-3} \text{ m}$$

$$\therefore \frac{150}{0.64} = \mu \frac{0.3}{1.5 \times 10^{-3}}$$

$$\therefore \mu = \frac{150 \times 1.5 \times 10^{-3}}{0.64 \times 0.3} = 1.17 \text{ N s/m}^2 = 1.17 \times 10 = 11.7 \text{ poise. Ans.}$$

**Problem 1.8** Two horizontal plates are placed 1.25 cm apart, the space between them being filled with oil of viscosity 14 poises. Calculate the shear stress in oil if upper plate is moved with a velocity of 2.5 m/s.

**Solution.** Given :

Distance between plates,  $dy = 1.25 \text{ cm} = 0.0125 \text{ m}$

Viscosity,  $\mu = 14 \text{ poise} = \frac{14}{10} \text{ N s/m}^2$

Velocity of upper plate,  $u = 2.5 \text{ m/sec.}$

Shear stress is given by equation (1.2) as,  $\tau = \mu \frac{du}{dy}$

where  $du = \text{Change of velocity between plates} = u - 0 = u = 2.5 \text{ m/sec.}$

$$dy = 0.0125 \text{ m.}$$

$$\therefore \tau = \frac{14}{10} \times \frac{2.5}{.0125} = 280 \text{ N/m}^2. \text{ Ans.}$$

**Problem 1.9** The space between two square flat parallel plates is filled with oil. Each side of the plate is 60 cm. The thickness of the oil film is 12.5 mm. The upper plate, which moves at 2.5 metre per sec requires a force of 98.1 N to maintain the speed. Determine :

(i) the dynamic viscosity of the oil in poise, and

(ii) the kinematic viscosity of the oil in stokes if the specific gravity of the oil is 0.95.

**Solution.** Given :

Each side of a square plate  $= 60 \text{ cm} = 0.60 \text{ m}$

$\therefore$  Area,  $A = 0.6 \times 0.6 = 0.36 \text{ m}^2$

Thickness of oil film,  $dy = 12.5 \text{ mm} = 12.5 \times 10^{-3} \text{ m}$

Velocity of upper plate,  $u = 2.5 \text{ m/sec}$



∴ Change of velocity between plates,  $du = 2.5 \text{ m/sec}$

Force required on upper plate,  $F = 98.1 \text{ N}$

∴ Shear stress, 
$$\tau = \frac{\text{Force}}{\text{Area}} = \frac{F}{A} = \frac{98.1 \text{ N}}{0.36 \text{ m}^2}$$

(i) Let  $\mu$  = Dynamic viscosity of oil

Using equation (1.2), 
$$\tau = \mu \frac{du}{dy} \text{ or } \frac{98.1}{0.36} = \mu \times \frac{2.5}{12.5 \times 10^{-3}}$$

∴ 
$$\mu = \frac{98.1}{0.36} \times \frac{12.5 \times 10^{-3}}{2.5} = 1.3635 \frac{\text{Ns}}{\text{m}^2} \quad \left( \because \frac{1 \text{ Ns}}{\text{m}^2} = 10 \text{ poise} \right)$$
  
$$= 1.3635 \times 10 = 13.635 \text{ poise. Ans.}$$

(ii) Sp. gr. of oil,  $S = 0.95$

Let  $\nu$  = kinematic viscosity of oil

Using equation (1.14),

Mass density of oil, 
$$\rho = S \times 1000 = 0.95 \times 1000 = 950 \text{ kg/m}^3$$

Using the relation,  $\nu = \frac{\mu}{\rho}$ , we get 
$$\nu = \frac{1.3635 \left( \frac{\text{Ns}}{\text{m}^2} \right)}{950} = .001435 \text{ m}^2/\text{sec} = .001435 \times 10^4 \text{ cm}^2/\text{s}$$
  
$$= 14.35 \text{ stokes. Ans.} \quad (\because \text{cm}^2/\text{s} = \text{stoke})$$

**Problem 1.10** Find the kinematic viscosity of an oil having density  $981 \text{ kg/m}^3$ . The shear stress at a point in oil is  $0.2452 \text{ N/m}^2$  and velocity gradient at that point is 0.2 per second.

**Solution.** Given :

Mass density, 
$$\rho = 981 \text{ kg/m}^3$$

Shear stress, 
$$\tau = 0.2452 \text{ N/m}^2$$

Velocity gradient, 
$$\frac{du}{dy} = 0.2 \text{ s}$$

Using the equation (1.2), 
$$\tau = \mu \frac{du}{dy} \text{ or } 0.2452 = \mu \times 0.2$$

∴ 
$$\mu = \frac{0.2452}{0.200} = 1.226 \text{ Ns/m}^2$$

Kinematic viscosity  $\nu$  is given by

∴ 
$$\nu = \frac{\mu}{\rho} = \frac{1.226}{981} = .125 \times 10^{-2} \text{ m}^2/\text{sec}$$

$$= 0.125 \times 10^{-2} \times 10^4 \text{ cm}^2/\text{s} = 0.125 \times 10^2 \text{ cm}^2/\text{s}$$

$$= 12.5 \text{ cm}^2/\text{s} = 12.5 \text{ stoke. Ans.}$$

(∵  $\text{cm}^2/\text{s} = \text{stoke}$ )

**Problem 1.11** Determine the specific gravity of a fluid having viscosity 0.05 poise and kinematic viscosity 0.035 stokes.

**Solution.** Given :

Viscosity, 
$$\mu = 0.05 \text{ poise} = \frac{0.05}{10} \text{ N s/m}^2$$



Kinematic viscosity,

$$\begin{aligned} \nu &= 0.035 \text{ stokes} \\ &= 0.035 \text{ cm}^2/\text{s} \\ &= 0.035 \times 10^{-4} \text{ m}^2/\text{s} \end{aligned}$$

$\therefore$  Stoke = cm

Using eqn  
Problem  
6 poise  
for

Using the relation  $\nu = \frac{\mu}{\rho}$ , we get  $0.035 \times 10^{-4} = \frac{0.05}{10} \times \frac{1}{\rho}$

$$\therefore \rho = \frac{0.05}{10} \times \frac{1}{0.035 \times 10^{-4}} = 1428.5 \text{ kg/m}^3$$

$$\therefore \text{Sp. gr. of liquid} = \frac{\text{Density of liquid}}{\text{Density of water}} = \frac{1428.5}{1000} = 1.4285 \approx 1.43. \text{ Ans.}$$

**Problem 1.12** Determine the viscosity of a liquid having kinematic viscosity 6 stokes and specific gravity 1.9.

**Solution.** Given :

Kinematic viscosity

$$\nu = 6 \text{ stokes} = 6 \text{ cm}^2/\text{s} = 6 \times 10^{-4} \text{ m}^2/\text{s}$$

Sp. gr. of liquid

$$= 1.9$$

Let the viscosity of liquid

$$= \mu$$

Now sp. gr. of a liquid

$$= \frac{\text{Density of the liquid}}{\text{Density of water}}$$

or

$$1.9 = \frac{\text{Density of liquid}}{1000}$$

$\therefore$  Density of liquid

$$= 1000 \times 1.9 = 1900 \frac{\text{kg}}{\text{m}^3}$$

$\therefore$  Using the relation

$$\nu = \frac{\mu}{\rho}, \text{ we get}$$

$$6 \times 10^{-4} = \frac{\mu}{1900}$$

or

$$\begin{aligned} \mu &= 6 \times 10^{-4} \times 1900 = 1.14 \text{ Ns/m}^2 \\ &= 1.14 \times 10 = 11.40 \text{ poise. Ans.} \end{aligned}$$

**Problem 1.13** The velocity distribution for flow over a flat plate is given by  $u = \frac{3}{4}y - y^2$  in which  $u$  is the velocity in metre per second at a distance  $y$  metre above the plate. Determine the shear stress at  $y = 0.15$  m. Take dynamic viscosity of fluid as 8.6 poise.

**Solution.** Given

$$u = \frac{3}{4}y - y^2$$

$\therefore$

$$\frac{du}{dy} = \frac{3}{4} - 2y$$

At  $y = 0.15$ ,

$$\frac{du}{dy} = \frac{3}{4} - 2 \times 0.15 = 0.75 - 0.30 = 0.45$$

Viscosity,

$$\mu = 8.6 \text{ poise} = \frac{8.6 \text{ Ns}}{10 \text{ m}^2}$$

$$\left( \because 10 \text{ poise} = 1 \frac{\text{Ns}}{\text{m}^2} \right)$$



Using equation (1.2),  $\tau = \mu \frac{du}{dy} = \frac{8.5}{10} \times 0.45 \frac{N}{m^2} = 0.3825 \frac{N}{m^2}$ . Ans.

**Problem 1.14** The dynamic viscosity of an oil, used for lubrication between a shaft and sleeve is 6 poise. The shaft is of diameter 0.4 m and rotates at 190 r.p.m. Calculate the power lost in the bearing for a sleeve length of 90 mm. The thickness of the oil film is 1.5 mm.

**Solution.** Given :

- Viscosity  $\mu = 6 \text{ poise} = \frac{6}{10} \frac{Ns}{m^2} = 0.6 \frac{Ns}{m^2}$
- Dia. of shaft,  $D = 0.4 \text{ m}$
- Speed of shaft,  $N = 190 \text{ r.p.m}$
- Sleeve length,  $L = 90 \text{ mm} = 90 \times 10^{-3} \text{ m}$
- Thickness of oil film,  $t = 1.5 \text{ mm} = 1.5 \times 10^{-3} \text{ m}$

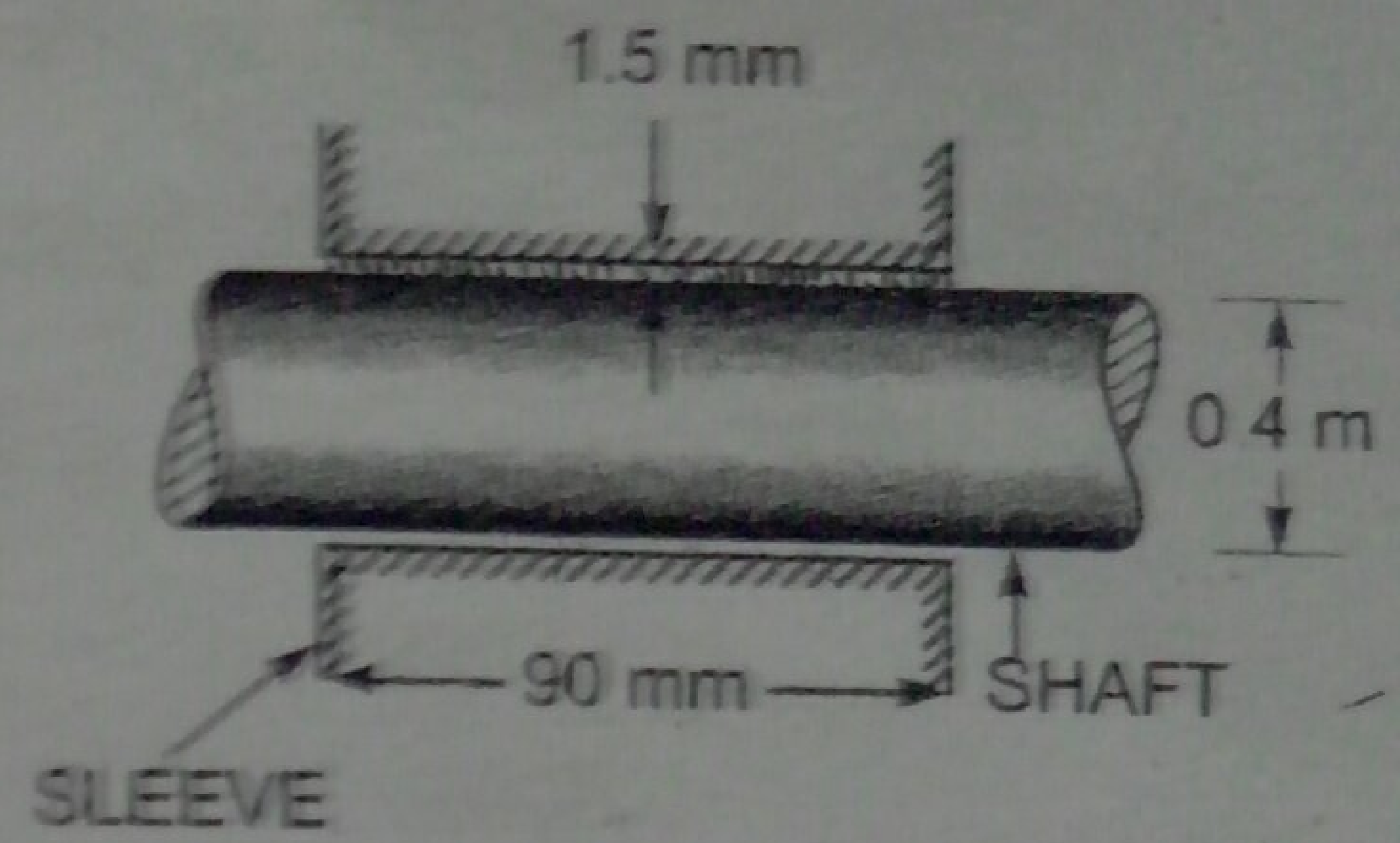

Fig. 1.5

Tangential velocity of shaft,  $u = \frac{\pi DN}{60} = \frac{\pi \times 0.4 \times 190}{60} = 3.98 \text{ m/s}$

Using the relation  $\tau = \mu \frac{du}{dy}$

where  $du = \text{Change of velocity} = u - 0 = u = 3.98 \text{ m/s}$   
 $dy = \text{Change of distance} = t = 1.5 \times 10^{-3} \text{ m}$

$\tau = 10 \times \frac{3.98}{1.5 \times 10^{-3}} = 1592 \text{ N/m}^2$

This is shear stress on shaft

$\therefore$  Shear force on the shaft,  $F = \text{Shear stress} \times \text{Area}$   
 $= 1592 \times \pi D \times L = 1592 \times \pi \times 0.4 \times 90 \times 10^{-3} = 180.05 \text{ N}$

Torque on the shaft,  $T = \text{Force} \times \frac{D}{2} = 180.05 \times \frac{0.4}{2} = 36.01 \text{ Nm}$

$\therefore$  \*Power lost  $= \frac{2\pi NT}{60} = \frac{2\pi \times 190 \times 36.01}{60} = 716.48 \text{ W. Ans.}$

**Problem 1.15** If the velocity profile of a fluid over a plate is parabolic with the vertex 20 cm from the plate, where the velocity is 120 cm/sec. Calculate the velocity gradients and shear stresses at a distance of 0, 10 and 20 cm from the plate, if the viscosity of the fluid is 8.5 poise.

**Solution.** Given :

Distance of vertex from plate = 20 cm

Velocity at vertex,  $u = 120 \text{ cm/sec}$

Viscosity,  $\mu = 8.5 \text{ poise} = \frac{8.5}{10} \frac{Ns}{m^2} = 0.85$

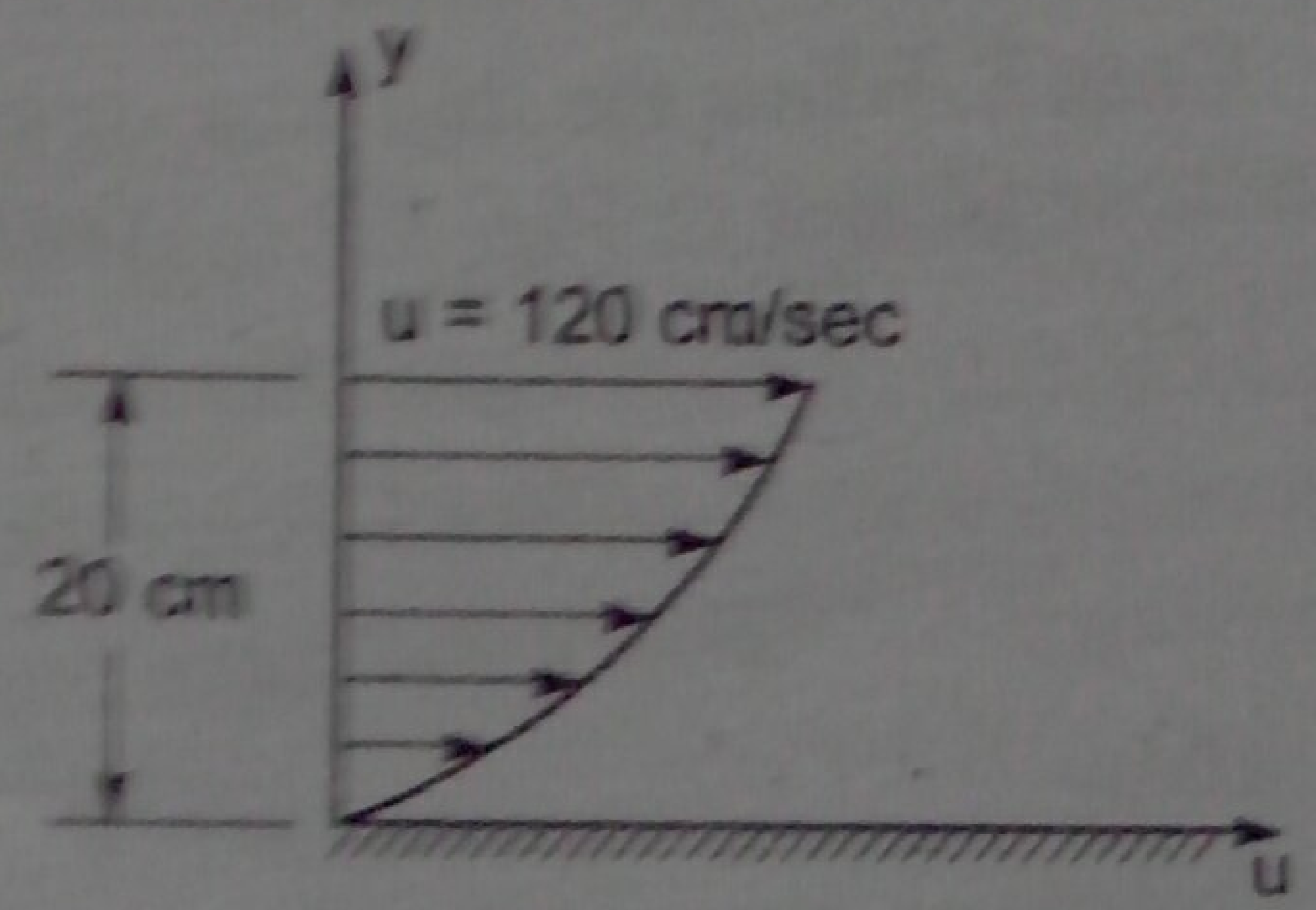

Fig. 1.6

\* Power in S.I. unit =  $T \cdot \omega = T \times \frac{2\pi N}{60} \text{ Watt} = \frac{2\pi NT}{60} \text{ Watt}$



The velocity profile is given parabolic and equation of velocity profile is

$$u = ay^2 + by + c \quad \dots(i)$$

where  $a$ ,  $b$  and  $c$  are constants. Their values are determined from boundary conditions as :

(a) at  $y = 0$ ,  $u = 0$

(b) at  $y = 20$  cm,  $u = 120$  cm/sec

(c) at  $y = 20$  cm,  $\frac{du}{dy} = 0$ .

Substituting boundary condition (a) in equation (i), we get

$$c = 0.$$

Boundary condition (b) on substitution in (i) gives

$$120 = a(20)^2 + b(20) = 400a + 20b \quad \dots(ii)$$

Boundary condition (c) on substitution in equation (i) gives

$$\frac{du}{dy} = 2ay + b \quad \dots(iii)$$

or

$$0 = 2 \times a \times 20 + b = 40a + b$$

Solving equations (ii) and (iii) for  $a$  and  $b$

From equation (iii),  $b = -40a$

Substituting this value in equation (ii), we get

$$120 = 400a + 20 \times (-40a) = 400a - 800a = -400a$$

$$\therefore a = \frac{120}{-400} = -\frac{3}{10} = -0.3$$

$$\therefore b = -40 \times (-0.3) = 12.0$$

Substituting the values of  $a$ ,  $b$  and  $c$  in equation (i),

$$u = -0.3y^2 + 12y.$$

### Velocity Gradient

$$\frac{du}{dy} = -0.3 \times 2y + 12 = -0.6y + 12$$

at  $y = 0$ , Velocity gradient,  $\left(\frac{du}{dy}\right)_{y=0} = -0.6 \times 0 + 12 = 12/s$ . Ans.

at  $y = 10$  cm,  $\left(\frac{du}{dy}\right)_{y=10} = -0.6 \times 10 + 12 = -6 + 12 = 6/s$ . Ans.

at  $y = 20$  cm,  $\left(\frac{du}{dy}\right)_{y=20} = -0.6 \times 20 + 12 = -12 + 12 = 0$ . Ans.

### Shear Stresses

Shear stress is given by,  $\tau = \mu \frac{du}{dy}$



(i) Shear stress at  $y=0$ ,  $\tau = \mu \left( \frac{du}{dy} \right)_{y=0} = 0.85 \times 12.0 = 10.2 \text{ N/m}^2$ .

(ii) Shear stress at  $y=10$ ,  $\tau = \mu \left( \frac{du}{dy} \right)_{y=10} = 0.85 \times 6.0 = 5.1 \text{ N/m}^2$ .

(iii) Shear stress at  $y=20$ ,  $\tau = \mu \left( \frac{du}{dy} \right)_{y=20} = 0.85 \times 0 = 0$ . Ans.

**Problem 1.16** A Newtonian fluid is filled in the clearance between a shaft and a concentric sleeve. The sleeve attains a speed of 50 cm/s when a force of 40 N is applied to the sleeve parallel to the shaft. Determine the speed if a force of 200 N is applied.

**Solution.** Given: Speed of sleeve,  $u_1 = 50 \text{ cm/s}$   
when force,  $F_1 = 40 \text{ N}$ .

Let speed of sleeve is  $u_2$  when force,  $F_2 = 200 \text{ N}$ .

Using relation  $\tau = \mu \frac{du}{dy}$

where  $\tau = \text{Shear stress} = \frac{\text{Force}}{\text{Area}} = \frac{F}{A}$

$du = \text{Change of velocity} = u - 0 = u$

$dy = \text{Clearance} = y$

$\therefore \frac{F}{A} = \mu \frac{u}{y}$

$\therefore F = \frac{\mu u A}{y}$

[ $\because A, \mu$  and  $y$  are constant]

$\therefore \frac{F_1}{F_2} = \frac{u_1}{u_2}$

Substituting values, we get  $\frac{40}{200} = \frac{50}{u_2}$

$\therefore u_2 = \frac{50 \times 200}{40} = 50 \times 5 = 250 \text{ cm/s}$ . Ans.

**Problem 1.17** A 15 cm diameter vertical cylinder rotates concentrically inside another cylinder of diameter 15.10 cm. Both cylinders are 25 cm high. The space between the cylinders is filled with a liquid whose viscosity is unknown. If a torque of 12.0 Nm is required to rotate the inner cylinder at 100 r.p.m., determine the viscosity of the fluid.

**Solution.** Given:

Diameter of cylinder = 15 cm = 0.15 m

Dia. of outer cylinder = 15.10 cm = 0.151 m

Length of cylinders,  $L = 25 \text{ cm} = 0.25 \text{ m}$

Torque,  $T = 12.0 \text{ Nm}$



Speed,

$$N = 100 \text{ r.p.m}$$

Let the viscosity

$$= \mu$$

$$\text{Tangential velocity of cylinder, } u = \frac{\pi DN}{60} = \frac{\pi \times 0.15 \times 100}{60} = 0.7854 \text{ m/s}$$

$$\text{Surface area of cylinder, } A = \pi D \times L = \pi \times 0.15 \times 0.25 = .1178 \text{ m}^2$$

$$\text{Now using relation } \tau = \mu \frac{du}{dy}$$

where  $du = u - 0 = u = .7854 \text{ m/s}$

$$dy = \frac{0.151 - 0.150}{2} \text{ m} = .0005 \text{ m}$$

$$\tau = \frac{\mu \times .7854}{.0005}$$

$$\therefore \text{ Shear force, } F = \text{Shear stress} \times \text{Area} = \frac{\mu \times .7854}{.0005} \times .1178$$

$$\therefore \text{ Torque, } T = F \times \frac{D}{2}$$

$$12.0 = \frac{\mu \times .7854}{.0005} \times .1178 \times \frac{.15}{2}$$

$$\therefore \mu = \frac{12.0 \times .0005 \times 2}{.7854 \times .1178 \times .15} = 0.864 \text{ N s/m}^2$$

$$= 0.864 \times 10 = 8.64 \text{ poise. Ans.}$$

**Problem 1.18** Two large plane surfaces are 2.4 cm apart. The space between the surfaces is filled with glycerine. What force is required to drag a very thin plate of surface area 0.5 square metre between the two large plane surfaces at a speed of 0.6 m/s, if:

- the thin plate is in the middle of the two plane surfaces, and
- the thin plate is at a distance of 0.8 cm from one of the plane surfaces? Take the dynamic viscosity of glycerine  $= 8.10 \times 10^{-1} \text{ N s/m}^2$ .

**Solution.** Given :

Distance between two large surfaces = 2.4 cm

Area of thin plate,  $A = 0.5 \text{ m}^2$

Velocity of thin plate,  $u = 0.6 \text{ m/s}$

Viscosity of glycerine,  $\mu = 8.10 \times 10^{-1} \text{ N s/m}^2$

Case I. When the thin plate is in the middle of the two plane surfaces [Refer to Fig. 1.7 (a)]

Let  $F_1$  = Shear force on the upper side of the thin plate

$F_2$  = Shear force on the lower side of the thin plate

$F$  = Total force required to drag the plate

Then  $F = F_1 + F_2$

The shear stress ( $\tau$ ) on the upper side of the thin plate is given by equation,

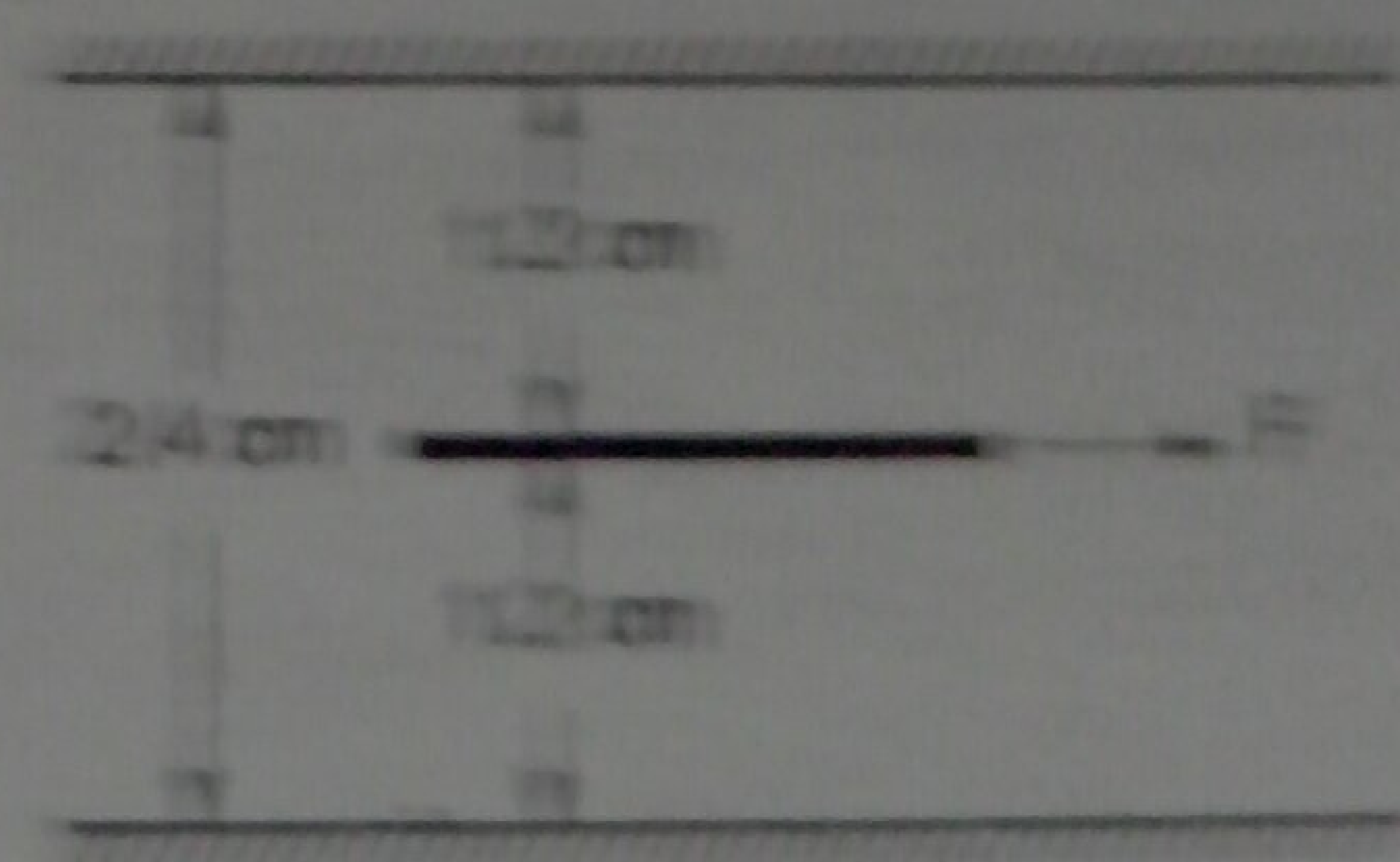

Fig. 1.7 (a)



$$\tau_1 = \mu \left( \frac{du}{dy} \right)_1$$

where  $du$  = Relative velocity between thin plate and upper large plane surface  
 = 0.6 m/sec

$dy$  = Distance between thin plate and upper large plane surface  
 = 1.2 cm = 0.012 m (plate is a thin one and hence thickness of plate is neglected)

$$\therefore \tau_1 = 8.10 \times 10^{-1} \times \left( \frac{0.6}{0.012} \right) = 40.5 \text{ N/m}^2$$

Now shear force,  $F_1 = \text{Shear stress} \times \text{Area}$   
 $= \tau_1 \times A = 40.5 \times 0.5 = 20.25 \text{ N}$

Similarly shear stress ( $\tau_2$ ) on the lower side of the thin plate is given by

$$\tau_2 = \mu \left( \frac{du}{dy} \right)_2 = 8.10 \times 10^{-1} \times \left( \frac{0.6}{0.012} \right) = 40.5 \text{ N/m}^2$$

$\therefore$  Shear force,  $F_2 = \tau_2 \times A = 40.5 \times 0.5 = 20.25 \text{ N}$

$\therefore$  Total force,  $F = F_1 + F_2 = 20.25 + 20.25 = 40.5 \text{ N. Ans.}$

**Case II.** When the thin plate is at a distance of 0.8 cm from one of the plane surfaces [Refer to Fig. 1.7 (b)].

Let the thin plate is at a distance 0.8 cm from the lower plane surface.

Then distance of the plate from the upper plane surface  
 = 2.4 - 0.8 = 1.6 cm = 0.016 m

(Neglecting thickness of the plate)

The shear force on the upper side of the thin plate,

$$F_1 = \text{Shear stress} \times \text{Area} = \tau_1 \times A$$

$$= \mu \left( \frac{du}{dy} \right)_1 \times A = 8.10 \times 10^{-1} \times \left( \frac{0.6}{0.016} \right) \times 0.5 = 15.18 \text{ N}$$

The shear force on the lower side of the thin plate,

$$F_2 = \tau_2 \times A = \mu \left( \frac{du}{dy} \right)_2 \times A$$

$$= 8.10 \times 10^{-1} \times \left( \frac{0.6}{0.8/100} \right) \times 0.5 = 30.36 \text{ N}$$

$\therefore$  Total force required =  $F_1 + F_2 = 15.18 + 30.36 = 45.54 \text{ N. Ans.}$

**Problem 1.19** A vertical gap 2.2 cm wide of infinite extent contains a fluid of viscosity 2.0 N s/m<sup>2</sup> and specific gravity 0.9. A metallic plate 1.2 m × 1.2 m × 0.2 cm is to be lifted up with a constant velocity of 0.15 m/sec, through the gap. If the plate is in the middle of the gap, find the force required. The weight of the plate is 40 N.

**Solution.** Given :

Width of gap = 2.2 cm, viscosity,  $\mu = 2.0 \text{ N s/m}^2$

Sq. gr. of fluid = 0.9

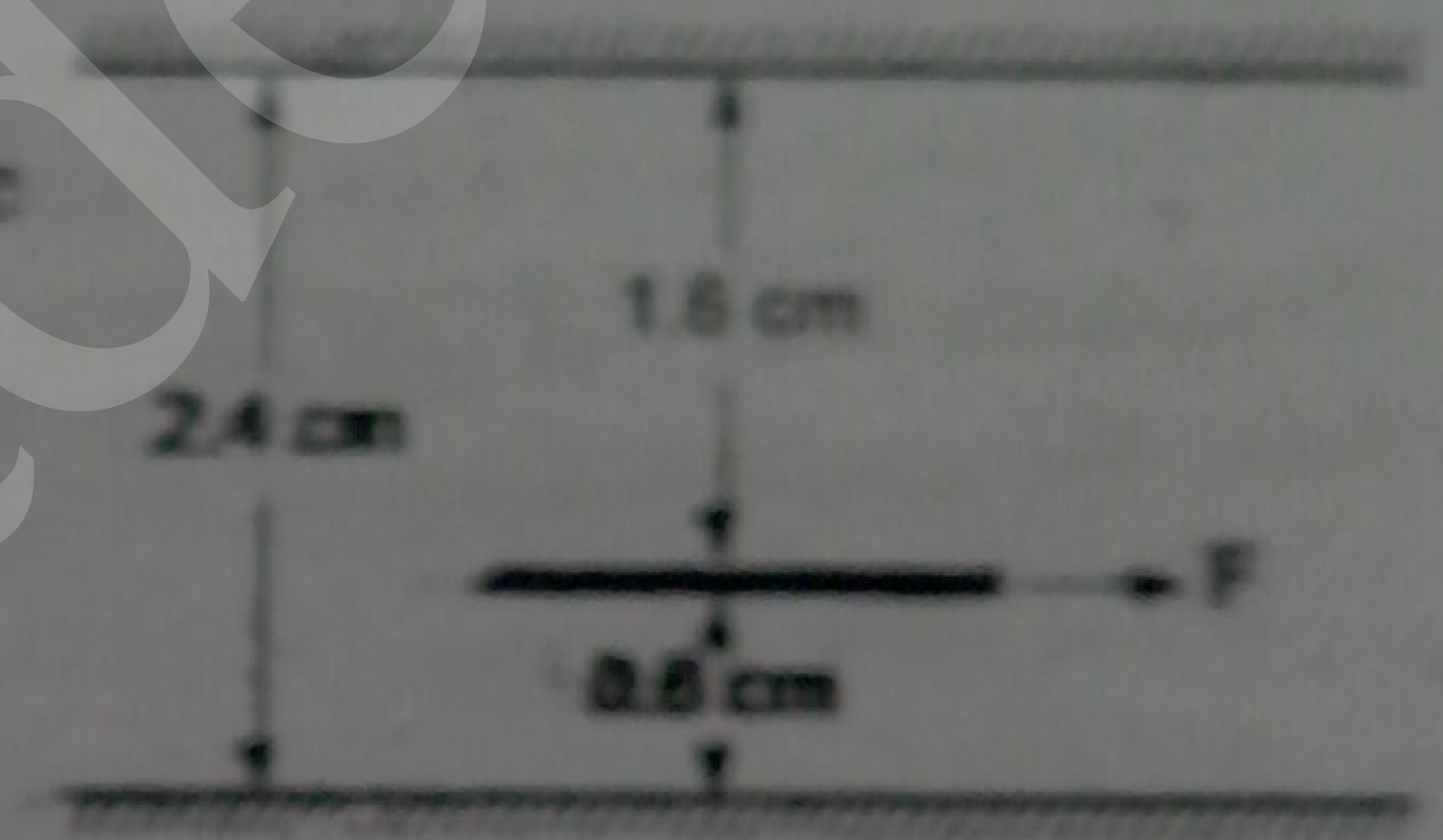

Fig. 1.7 (b)



∴ Weight density of fluid

$$= 0.9 \times 1000 = 900 \text{ kg/m}^3 = 900 \times 9.81 \text{ N/m}^3$$

$$(\because 1 \text{ kgf} = 9.81 \text{ N})$$

Volume of plate

$$= 1.2 \text{ m} \times 1.2 \text{ m} \times 0.2 \text{ cm}$$

$$= 1.2 \times 1.2 \times .002 \text{ m}^3 = .00288 \text{ m}^3$$

Thickness of plate

$$= 0.2 \text{ cm}$$

Velocity of plate

$$= 0.15 \text{ m/sec}$$

Weight of plate

$$= 40 \text{ N.}$$

When plate is in the middle of the gap, the distance of the plate from vertical surface of the gap

$$= \left( \frac{\text{Width of gap} - \text{Thickness of plate}}{2} \right)$$

$$= \frac{(2.2 - 0.2)}{2} = 1 \text{ cm} = .01 \text{ m.}$$

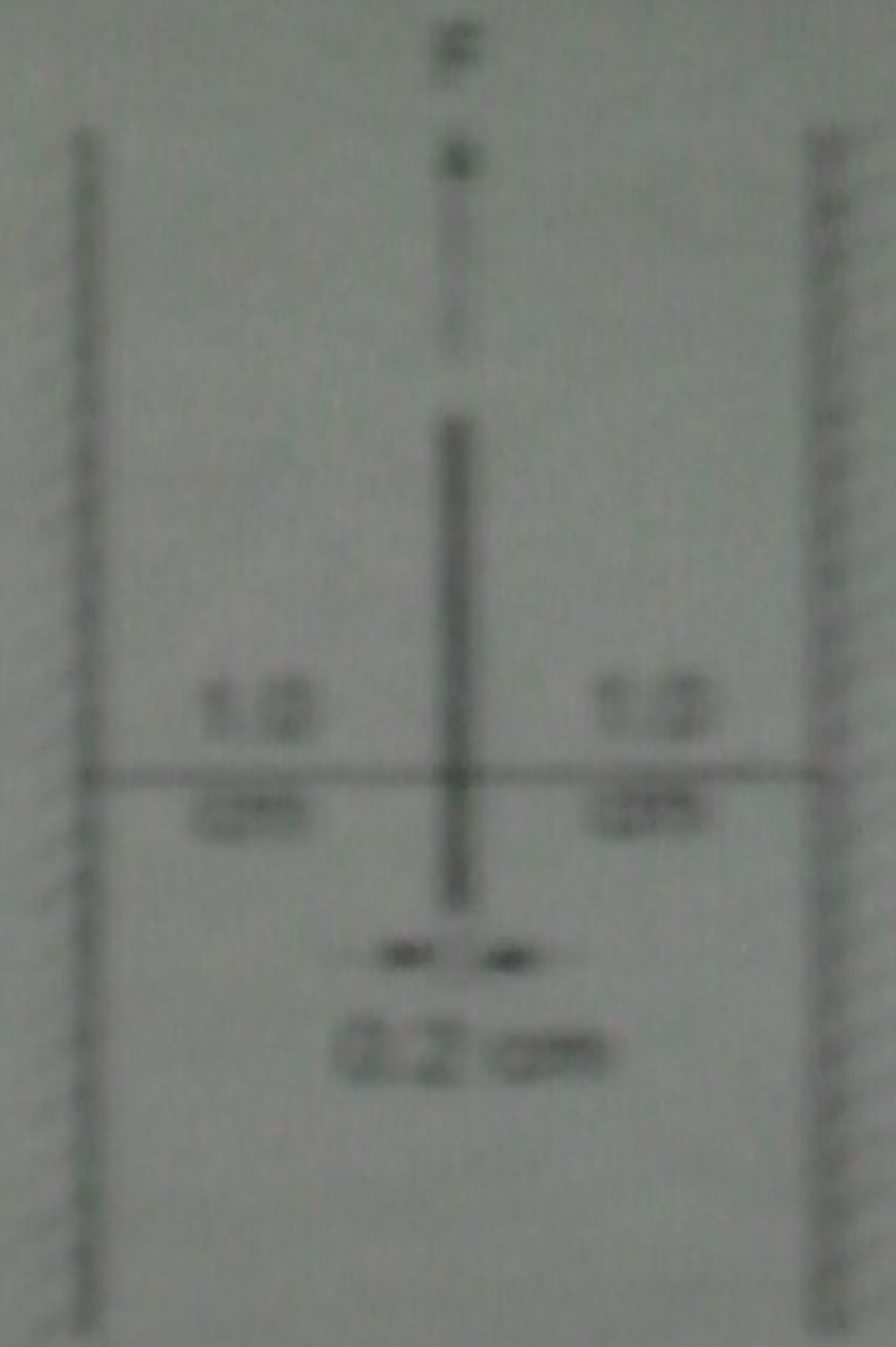

Fig. 1.8

Now the shear force on the left side of the metallic plate,

$$F_1 = \text{Shear stress} \times \text{Area}$$

$$= \mu \left( \frac{du}{dy} \right)_1 \times \text{Area} = 2.0 \times \left( \frac{0.15}{.01} \right) \times 1.2 \times 1.2 \text{ N}$$

$$(\because \text{Area} = 1.2 \times 1.2 \text{ m}^2)$$

$$= 43.2 \text{ N.}$$

Similarly, the shear force on the right side of the metallic plate,

$$F_2 = \text{Shear stress} \times \text{Area} = 2.0 \times \left( \frac{0.15}{.01} \right) \times 1.2 \times 1.2 = 43.2 \text{ N}$$

∴ Total shear force

$$= F_1 + F_2 = 43.2 + 43.2 = 86.4 \text{ N.}$$

In this case the weight of plate (which is acting vertically downward) and upward thrust is also to be taken into account.

The upward thrust = Weight of fluid displaced

$$= (\text{Weight density of fluid}) \times \text{Volume of fluid displaced}$$

$$= 9.81 \times 900 \times .00288 \text{ N}$$

$$(\because \text{Volume of fluid displaced} = \text{Volume of plate} = .00288)$$

$$= 25.43 \text{ N.}$$

The net force acting in the downward direction due to weight of the plate and upward thrust

$$= \text{Weight of plate} - \text{Upward thrust} = 40 - 25.43 = 14.57 \text{ N}$$

∴ Total force required to lift the plate up

$$= \text{Total shear force} + 14.57 = 86.4 + 14.57 = 100.97 \text{ N. Ans.}$$

### ► 1.4 THERMODYNAMIC PROPERTIES

Fluids consist of liquids or gases. But gases are compressible fluids and hence thermodynamic properties play an important role. With the change of pressure and temperature, the gases undergo



large variation in density. The relationship between pressure (absolute), specific volume and temperature (absolute) of a gas is given by the equation of state as

$$p \forall = RT \text{ or } \frac{p}{\rho} = RT \quad \dots(1.5)$$

where  $p$  = Absolute pressure of a gas in  $\text{N/m}^2$

$\forall$  = Specific volume =  $\frac{1}{\rho}$

$R$  = Gas constant

$T$  = Absolute temperature in  $^{\circ}\text{K}$

$\rho$  = Density of a gas.

**1.4.1 Dimension of R.** The gas constant,  $R$ , depends upon the particular gas. The dimension of  $R$  is obtained from equation (1.5) as

$$R = \frac{p}{\rho T}$$

(i) In MKS units

$$R = \frac{\text{kgf}/\text{m}^2}{\left(\frac{\text{kg}}{\text{m}^3}\right)^{\circ}\text{K}} = \frac{\text{kgf}\cdot\text{m}}{\text{kg}\cdot^{\circ}\text{K}}$$

(ii) In SI units,  $p$  is expressed in Newton/ $\text{m}^2$  or  $\text{N/m}^2$ .

$\therefore$

$$R = \frac{\text{N}/\text{m}^2}{\frac{\text{kg}}{\text{m}^3}\cdot^{\circ}\text{K}} = \frac{\text{Nm}}{\text{kg}\cdot^{\circ}\text{K}} = \frac{\text{Joule}}{\text{kg}\cdot^{\circ}\text{K}} \quad [\text{Joule} = \text{Nm}]$$

$$= \frac{\text{J}}{\text{kg}\cdot^{\circ}\text{K}}$$

For air,

$$R \text{ in MKS} = 29.3 \frac{\text{kgf}\cdot\text{m}}{\text{kg}\cdot^{\circ}\text{K}}$$

$$R \text{ in SI} = 29.3 \times 9.81 \frac{\text{Nm}}{\text{kg}\cdot^{\circ}\text{K}} = 287 \frac{\text{J}}{\text{kg}\cdot^{\circ}\text{K}}$$

**1.4.2 Isothermal Process.** If the change in density occurs at constant temperature, then the process is called isothermal and relationship between pressure ( $p$ ) and density ( $\rho$ ) is given by

$$\frac{p}{\rho} = \text{Constant} \quad \dots(1.6)$$

**1.4.3 Adiabatic Process.** If the change in density occurs with no heat exchange to and from the gas, the process is called adiabatic. And if no heat is generated within the gas due to friction, the relationship between pressure and density is given by

$$\frac{p}{\rho^k} = \text{Constant} \quad \dots(1.7)$$

where  $k$  = Ratio of specific heat of a gas at constant pressure and constant volume.  
= 1.4 for air.



## 1.4.4 Universal Gas Constant

Let

$m$  = Mass of a gas in kg

$V$  = Volume of gas of mass  $m$

$p$  = Absolute pressure

$T$  = Absolute temperature

$$pV = mRT \quad \dots(1.8)$$

Then, we have where  $R$  = Gas constant.

Equation (1.8) can be made universal, i.e., applicable to all gases if it is expressed in mole-basis.

Let

$n$  = Number of moles in volume of a gas

$V$  = Volume of the gas

$M$  =  $\frac{\text{Mass of the gas molecules}}{\text{Mass of a hydrogen atom}}$

$m$  = Mass of a gas in kg

Then, we have  $n \times M = m$ .

Substituting the value of  $m$  in equation (1.8), we get

$$pV = n \times M \times RT \quad \dots(1.9)$$

The product  $M \times R$  is called universal gas constant and is equal to  $848 \frac{\text{kgf} \cdot \text{m}}{\text{kg} \cdot \text{mole} \cdot ^\circ\text{K}}$  in MKS units

and  $8314 \text{ J/kg-mole} \cdot \text{K}$  in SI units.

One kilogram mole is defined as the product of one kilogram mass of the gas and its molecular weight.

**Problem 1.20** A gas weighs  $16 \text{ N/m}^3$  at  $25^\circ\text{C}$  and at an absolute pressure of  $0.25 \text{ N/mm}^2$ . Determine the gas constant and density of the gas.

**Solution.** Given :

Weight density,

$$w = 16 \text{ N/m}^3$$

Temperature,

$$t = 25^\circ\text{C}$$

$\therefore$

$$T = 273 + t = 273 + 25 = 298^\circ\text{K}$$

$$p = 0.25 \text{ N/mm}^2 \text{ (abs.)} = 0.25 \times 10^6 \text{ N/m}^2 = 25 \times 10^4 \text{ N/m}^2$$

(i) Using relation  $w = \rho g$ , density is obtained as

$$\rho = \frac{w}{g} = \frac{16}{9.81} = 1.63 \text{ kg/m}^3 \text{ Ans.}$$

(ii) Using equation (1.5),  $\frac{p}{\rho} = RT$

$$R = \frac{p}{\rho T} = \frac{25 \times 10^4}{1.63 \times 298} = 532.55 \frac{\text{Nm}}{\text{kg} \cdot \text{K}} \text{ Ans.}$$

**Problem 1.21** A cylinder of  $0.6 \text{ m}^3$  in volume contains air at  $50^\circ\text{C}$  and  $0.3 \text{ N/mm}^2$  absolute pressure. The air is compressed to  $0.3 \text{ m}^3$ . Find (i) pressure inside the cylinder assuming isothermal process and (ii) pressure and temperature assuming adiabatic process. Take  $k = 1.4$ .

**Solution.** Given :

Initial volume,

$$V_1 = 0.6 \text{ m}^3$$



Temperature  $t_1 = 50^\circ\text{C}$   
 $\therefore T_1 = 273 + 50 = 323^\circ\text{K}$   
 Pressure  $p_1 = 0.3 \text{ N/mm}^2 = 0.3 \times 10^6 \text{ N/m}^2 = 30 \times 10^4 \text{ N/m}^2$   
 Final volume  $V_2 = 0.3 \text{ m}^3$   
 $k = 1.4$

(i) Isothermal process :

Using equation (1.6),  $\frac{P}{\rho} = \text{Constant}$  or  $pV = \text{Constant}$ .  
 $\therefore p_1 V_1 = p_2 V_2$   
 $\therefore p_2 = \frac{p_1 V_1}{V_2} = \frac{30 \times 10^4 \times 0.6}{0.3} = 0.6 \times 10^6 \text{ N/m}^2 = 0.6 \text{ N/mm}^2. \text{ Ans.}$

(ii) Adiabatic process :

Using equation (1.7),  $\frac{P}{\rho^k} = \text{Constant}$  or  $p V^k = \text{Constant}$   
 $\therefore p_1 V_1^k = p_2 V_2^k$   
 $\therefore p_2 = p_1 \frac{V_1^k}{V_2^k} = 30 \times 10^4 \times \left(\frac{0.6}{0.3}\right)^{1.4} = 30 \times 10^4 \times 2^{1.4}$   
 $= 0.791 \times 10^6 \text{ N/m}^2 = 0.791 \text{ N/mm}^2. \text{ Ans.}$

For temperature, using equation (1.5), we get

$pV = RT$  and also  $p V^k = \text{Constant}$

$\therefore p = \frac{RT}{V}$  and  $\frac{RT}{V} \times V^k = \text{Constant}$

or  $RTV^{k-1} = \text{Constant}$   
 or  $T V^{k-1} = \text{Constant}$  ( $\because R$  is also constant)

$\therefore T_1 V_1^{k-1} = T_2 V_2^{k-1}$

$\therefore T_2 = T_1 \left(\frac{V_1}{V_2}\right)^{k-1} = 323 \left(\frac{0.6}{0.3}\right)^{1.4-1.0} = 323 \times 2^{0.4} = 426.2^\circ\text{K}$

$\therefore t_2 = 426.2 - 273 = 153.2^\circ\text{C. Ans.}$

**Problem 1.22** Calculate the pressure exerted by 5 kg of nitrogen gas at a temperature of  $10^\circ\text{C}$  if the volume is  $0.4 \text{ m}^3$ . Molecular weight of nitrogen is 28. Assume, ideal gas laws are applicable.

**Solution.** Given :

Mass of nitrogen = 5 kg  
 Temperature,  $t = 10^\circ\text{C}$   
 $\therefore T = 273 + 10 = 283^\circ\text{K}$   
 Volume of nitrogen,  $V = 0.4 \text{ m}^3$   
 Molecular weight = 28

Using equation (1.9), we have  $pV = n \times M \times RT$



where  $M \times R = \text{Universal gas constant} = 8314 \frac{\text{Nm}}{\text{kg-mole}^\circ\text{K}}$

and one kg-mole = (kg-mass)  $\times$  Molecular weight = (kg-mass)  $\times$  28

$$\therefore R \text{ for nitrogen} = \frac{8314}{28} = 296.9 \frac{\text{Nm}}{\text{kg}^\circ\text{K}}$$

The gas laws for nitrogen is  $pV = mRT$ , where  $R = \text{Characteristic gas constant}$   
or  $p \times 0.4 = 5 \times 296.9 \times 283$

$$\therefore p = \frac{5 \times 296.9 \times 283}{0.4} = 1050283.7 \text{ N/m}^2 = 1.05 \text{ N/mm}^2, \text{ Ans.}$$

## ► 1.5 COMPRESSIBILITY AND BULK MODULUS

Compressibility is the reciprocal of the bulk modulus of elasticity,  $K$  which is defined as the ratio of compressive stress to volumetric strain.

Consider a cylinder fitted with a piston as shown in Fig. 1.9.

Let  $V = \text{Volume of a gas enclosed in the cylinder}$

$p = \text{Pressure of gas when volume is } V$

Let the pressure is increased to  $p + dp$ , the volume of gas decreases from  $V$  to  $V - dV$ .

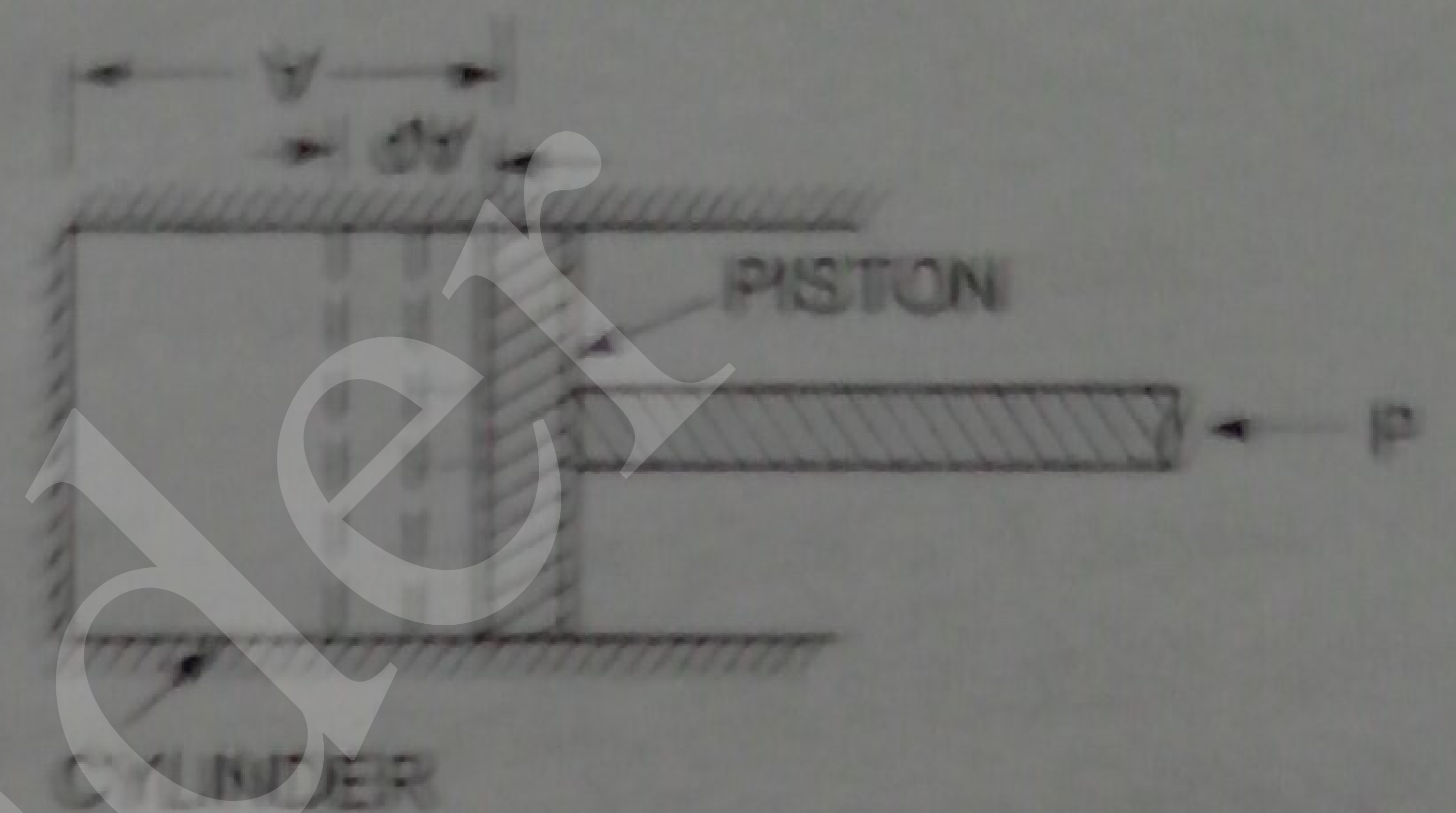

Fig. 1.9

Then increase in pressure =  $dp \text{ kgf/m}^2$

Decrease in volume =  $dV$

$$\therefore \text{Volumetric strain} = -\frac{dV}{V}$$

—ve sign means the volume decreases with increase of pressure.

$$\therefore \text{Bulk modulus } K = \frac{\text{Increase of pressure}}{\text{Volumetric strain}}$$

$$= \frac{dp}{-\frac{dV}{V}} = -\frac{dp}{\frac{dV}{V}} \quad \dots(1.10)$$

$$\text{Compressibility} = \frac{1}{K} \quad \dots(1.11)$$

## Relationship between Bulk Modulus ( $K$ ) and Pressure ( $p$ ) for a Gas

The relationship between bulk modulus of elasticity ( $K$ ) and pressure for a gas for two different processes of compression are as :

(i) For Isothermal Process. Equation (1.6) gives the relationship between pressure ( $p$ ) and density ( $\rho$ ) of a gas as

$$\frac{p}{\rho} = \text{Constant}$$



or

$$p\forall = \text{Constant}$$

$$\left\{ \forall = \frac{1}{\rho} \right\}$$

Differentiating this equation, we get ( $p$  and  $\forall$  both are variables)

$$pd\forall + \forall dp = 0 \quad \text{or} \quad pd\forall = -\forall dp \quad \text{or} \quad p = \frac{-\forall dp}{d\forall}$$

Substituting this value in equation (1.10), we get

$$K = p$$

...(1.12)

(ii) For Adiabatic Process. Using equation (1.7) for adiabatic process

$$\frac{p}{\rho^k} = \text{Constant} \quad \text{or} \quad p \forall^k = \text{Constant}$$

Differentiating, we get  $pd(\forall^k) + \forall^k(dp) = 0$

or  $p \times k \times \forall^{k-1} d\forall + \forall^k dp = 0$

or  $pkd\forall + \forall dp = 0$

[Cancelling  $\forall^{k-1}$  to both sides]

or  $pkd\forall = -\forall dp \quad \text{or} \quad pk = -\frac{\forall dp}{d\forall}$

Hence from equation (1.10), we have

$$K = pk$$

...(1.13)

where  $K$  = Bulk modulus and  $k$  = Ratio of specific heats.

**Problem 1.23** Determine the bulk modulus of elasticity of a liquid, if the pressure of the liquid is increased from  $70 \text{ N/cm}^2$  to  $130 \text{ N/cm}^2$ . The volume of the liquid decreases by 0.15 per cent.

**Solution.** Given :

Initial pressure =  $70 \text{ N/cm}^2$

Final pressure =  $130 \text{ N/cm}^2$

$\therefore dp = \text{Increase in pressure} = 130 - 70 = 60 \text{ N/cm}^2$

Decrease in volume =  $0.15\%$

$\therefore -\frac{d\forall}{\forall} = +\frac{0.15}{100}$

Bulk modulus,  $K$  is given by equation (1.10) as

$$K = \frac{dp}{-\frac{d\forall}{\forall}} = \frac{60 \text{ N/cm}^2}{\frac{.15}{100}} = \frac{60 \times 100}{.15} = 4 \times 10^4 \text{ N/cm}^2. \text{ Ans.}$$

**Problem 1.24** What is the bulk modulus of elasticity of a liquid which is compressed in a cylinder from a volume of  $0.0125 \text{ m}^3$  at  $80 \text{ N/cm}^2$  pressure to a volume of  $0.0124 \text{ m}^3$  at  $150 \text{ N/cm}^2$  pressure ?

**Solution.** Given :

Initial volume,  $\forall = 0.0125 \text{ m}^3$

Final volume =  $0.0124 \text{ m}^3$

$\therefore$  Decrease in volume,  $d\forall = .0125 - .0124 = .0001 \text{ m}^3$



$$\frac{dV}{V} = \frac{.0001}{.0125}$$

Initial pressure

$$= 80 \text{ N/cm}^2$$

Final pressure

$$= 150 \text{ N/cm}^2$$

∴ Increase in pressure,  $dp = (150 - 80) = 70 \text{ N/cm}^2$

Bulk modulus is given by equation (1.10) as

$$K = \frac{dp}{\frac{dV}{V}} = \frac{70}{\frac{.0001}{.0125}} = 70 \times 125 \text{ N/cm}^2$$

$$= 8.75 \times 10^3 \text{ N/cm}^2. \text{ Ans.}$$

## ► 1.6 SURFACE TENSION AND CAPILLARITY

Surface tension is defined as the tensile force acting on the surface of a liquid in contact with a gas or on the surface between two immiscible liquids such that the contact surface behaves like a membrane under tension. The magnitude of this force per unit length of the free surface will have the same value as the surface energy per unit area. It is denoted by Greek letter  $\sigma$  (called sigma). In MKS units, it is expressed as kgf/m while in SI units as N/m.

The phenomenon of surface tension is explained by Fig. 1.10. Consider three molecules A, B, C of a liquid in a mass of liquid. The molecule A is attracted in all directions equally by the surrounding molecules of the liquid. Thus the resultant force acting on the molecule A is zero. But the molecule B, which is situated near the free surface, is acted upon by upward and downward forces which are unbalanced. Thus a net resultant force on molecule B is acting in the downward direction. The molecule C, situated on the free surface of liquid, does experience a resultant downward force. All the molecules on the free surface experience a downward force. Thus the free surface of the liquid acts like a very thin film under tension of the surface of the liquid act as though it is an elastic membrane under tension.

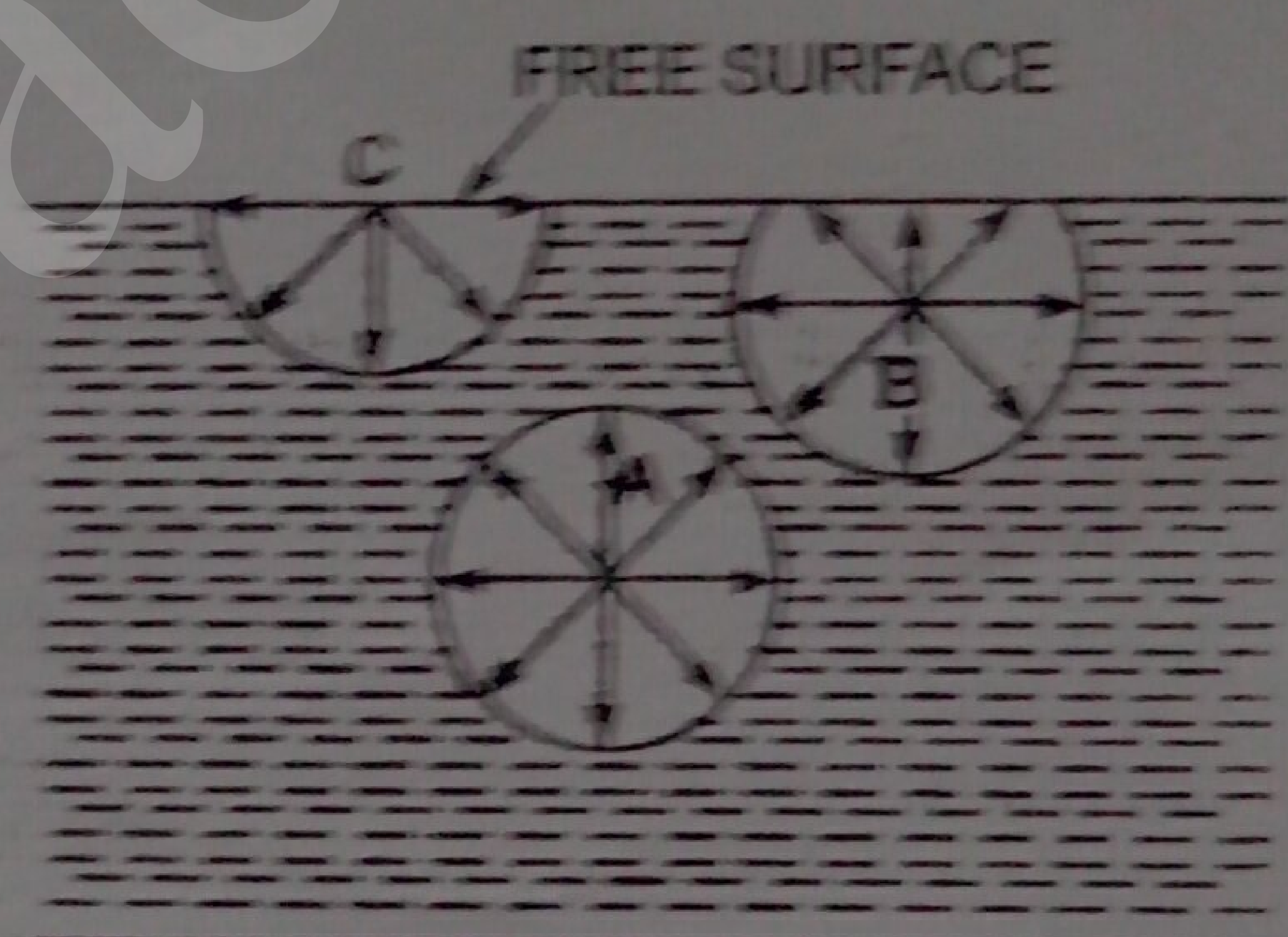

Fig. 1.10 Surface tension.

**1.6.1 Surface Tension on Liquid Droplet.** Consider a small spherical droplet of a liquid of radius ' $r$ '. On the entire surface of the droplet, the tensile force due to surface tension will be acting.

Let  $\sigma$  = Surface tension of the liquid

$p$  = Pressure intensity inside the droplet (in excess of the outside pressure intensity)

$d$  = Dia. of droplet.

Let the droplet is cut into two halves. The forces acting on one half (say left half) will be

(i) tensile force due to surface tension acting around the circumference of the cut portion as shown in Fig. 1.11 (b) and this is equal to

$$= \sigma \times \text{Circumference}$$

$$= \sigma \times \pi d$$



(ii) pressure force on the area  $\frac{\pi}{4} d^2 = p \times \frac{\pi}{4} d^2$  as shown in

Fig. 1.11 (c). These two forces will be equal and opposite under equilibrium conditions, i.e.,

$$p \times \frac{\pi}{4} d^2 = \sigma \times \pi d$$

or 
$$p = \frac{\sigma \times \pi d}{\frac{\pi}{4} \times d^2} = \frac{4\sigma}{d} \dots(1.14)$$

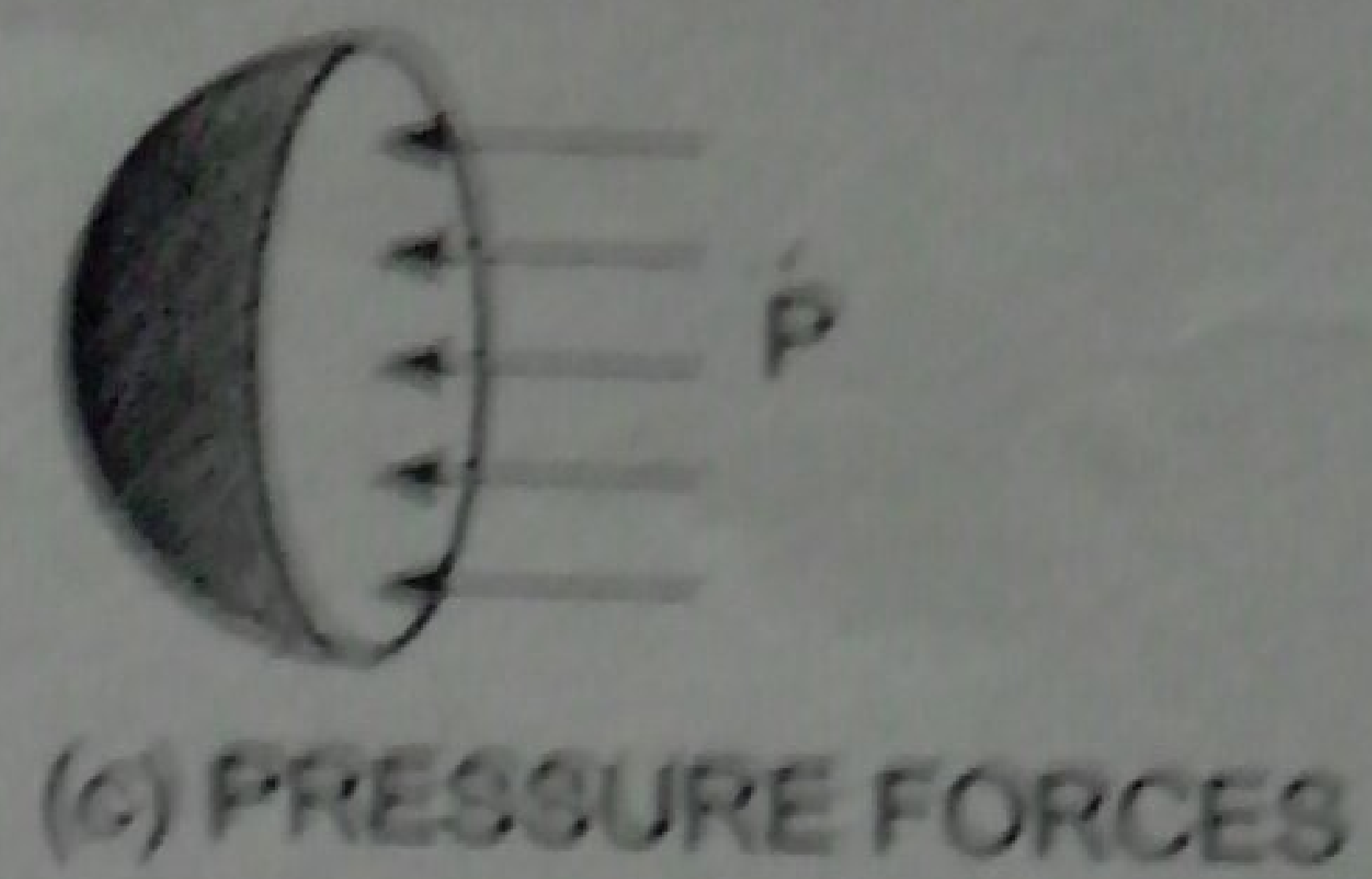
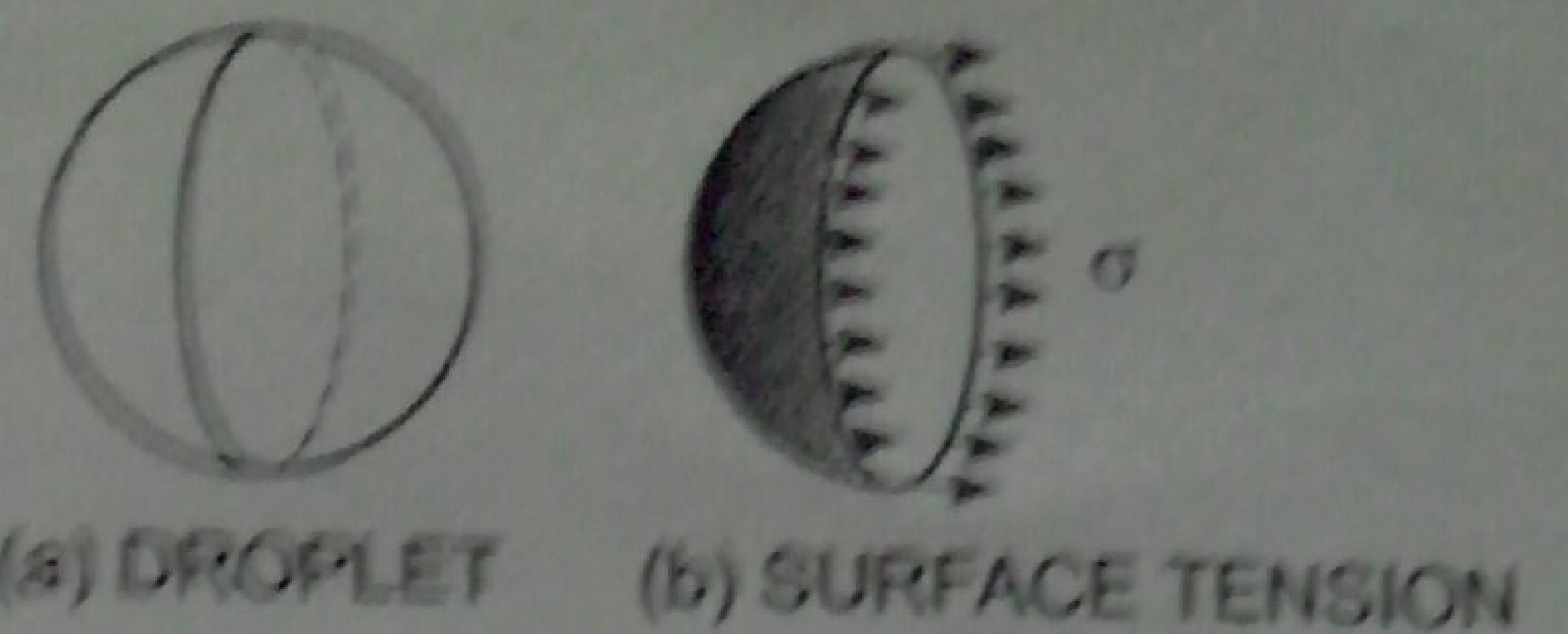

Equation (1.14) shows that with the decrease of diameter, of the droplet, pressure intensity inside the droplet increases.

Fig. 1.11 Forces on droplet.

**1.6.2 Surface Tension on a Hollow Bubble.** A hollow bubble like a soap bubble in air has two surfaces in contact with air, one inside and other outside. Thus two surfaces are subjected to surface tension. In such case, we have

$$p \times \frac{\pi}{4} d^2 = 2 \times (\sigma \times \pi d)$$

∴ 
$$p = \frac{2\sigma \pi d}{\frac{\pi}{4} d^2} = \frac{8\sigma}{d} \dots(1.15)$$

**1.6.3 Surface Tension on a Liquid Jet.** Consider a liquid jet of diameter 'd' and length 'L' as shown in Fig. 1.12.

Let  $p$  = Pressure intensity inside the liquid jet above the outside pressure  
 $\sigma$  = Surface tension of the liquid.

Consider the equilibrium of the semi jet, we have

Force due to pressure =  $p \times \text{area of semi jet}$   
 =  $p \times L \times d$

Force due to surface tension =  $\sigma \times 2L$

Equating the forces, we have

$$p \times L \times d = \sigma \times 2L$$

∴ 
$$p = \frac{\sigma \times 2L}{L \times d} \dots(1.16)$$

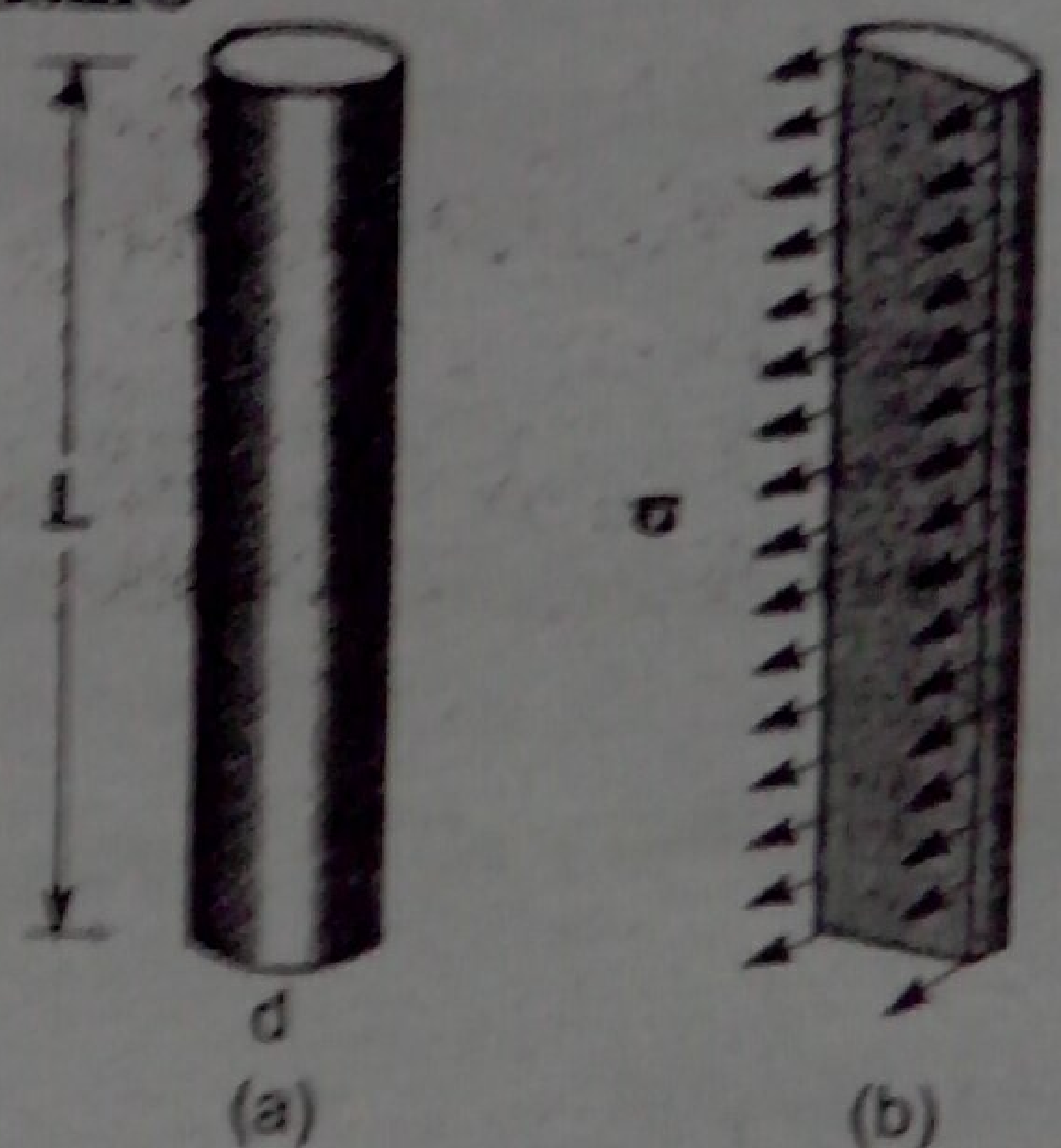

Fig. 1.12 Forces on liquid jet.

**Problem 1.25** The surface tension of water in contact with air at 20°C is 0.0725 N/m. The pressure inside a droplet of water is to be 0.02 N/cm<sup>2</sup> greater than the outside pressure. Calculate the diameter of the droplet of water.

**Solution.** Given :

Surface tension,  $\sigma = 0.0725 \text{ N/m}$

Pressure intensity,  $p$  in excess of outside pressure is

$$p = 0.02 \text{ N/cm}^2 = 0.02 \times 10^4 \frac{\text{N}}{\text{m}^2}$$

Let  $d = \text{dia. of the droplet}$



Using equation (1.14), we get  $p = \frac{4\sigma}{d}$  or  $0.02 \times 10^4 = \frac{4 \times 0.0725}{d}$

$$\therefore d = \frac{4 \times 0.0725}{0.02 \times (10)^4} = .00145 \text{ m} = .00145 \times 1000 = 1.45 \text{ mm. Ans.}$$

**Problem 1.26** Find the surface tension in a soap bubble of 40 mm diameter when the inside pressure is  $2.5 \text{ N/m}^2$  above atmospheric pressure.

**Solution.** Given:

Dia. of bubble,  $d = 40 \text{ mm} = 40 \times 10^{-3} \text{ m}$

Pressure in excess of outside,  $p = 2.5 \text{ N/m}^2$

For a soap bubble, using equation (1.15), we get

$$p = \frac{8\sigma}{d} \quad \text{or} \quad 2.5 = \frac{8 \times \sigma}{40 \times 10^{-3}}$$

$$\sigma = \frac{2.5 \times 40 \times 10^{-3}}{8} \text{ N/m} = 0.0125 \text{ N/m. Ans.}$$

**Problem 1.27** The pressure outside the droplet of water of diameter 0.04 mm is  $10.32 \text{ N/cm}^2$  (atmospheric pressure). Calculate the pressure within the droplet if surface tension is given as  $0.0725 \text{ N/m}$  of water.

**Solution.** Given:

Dia. of droplet,  $d = 0.04 \text{ mm} = .04 \times 10^{-3} \text{ m}$

Pressure outside the droplet  $= 10.32 \text{ N/cm}^2 = 10.32 \times 10^4 \text{ N/m}^2$

Surface tension,  $\sigma = 0.0725 \text{ N/m}$

The pressure inside the droplet, in excess of outside pressure is given by equation (1.14)

$$p = \frac{4\sigma}{d} = \frac{4 \times 0.0725}{.04 \times 10^{-3}} = 7250 \text{ N/m}^2 = \frac{7250 \text{ N}}{10^4 \text{ cm}^2} = 0.725 \text{ N/cm}^2$$

$\therefore$  Pressure inside the droplet  $= p +$  Pressure outside the droplet  
 $= 0.725 + 10.32 = 11.045 \text{ N/cm}^2. \text{ Ans.}$

**1.16.4 Capillarity.** Capillarity is defined as a phenomenon of rise or fall of a liquid surface, in a small tube relative to the adjacent general level of liquid when the tube is held vertically in the liquid. The rise of liquid surface is known as capillary rise while the fall of the liquid surface is known as capillary depression. It is expressed in terms of cm or mm of liquid. Its value depends upon the specific weight of the liquid, diameter of the tube and surface tension of the liquid.

**Expression for Capillary Rise.** Consider a glass tube of small diameter  $d$  opened at both ends and is inserted in a liquid, say water. The liquid will rise in the tube above the level of the liquid.

Let  $h$  = height of the liquid in the tube. Under a state of equilibrium, the weight of liquid of height  $h$  is balanced by the force at the surface of the liquid in the tube. But the force at the surface of the liquid in the tube is due to surface tension.

Let  $\sigma$  = Surface tension of liquid

$\theta$  = Angle of contact between liquid and glass tube.

The weight of liquid of height  $h$  in the tube  $= (\text{Area of tube} \times h) \times \rho \times g$

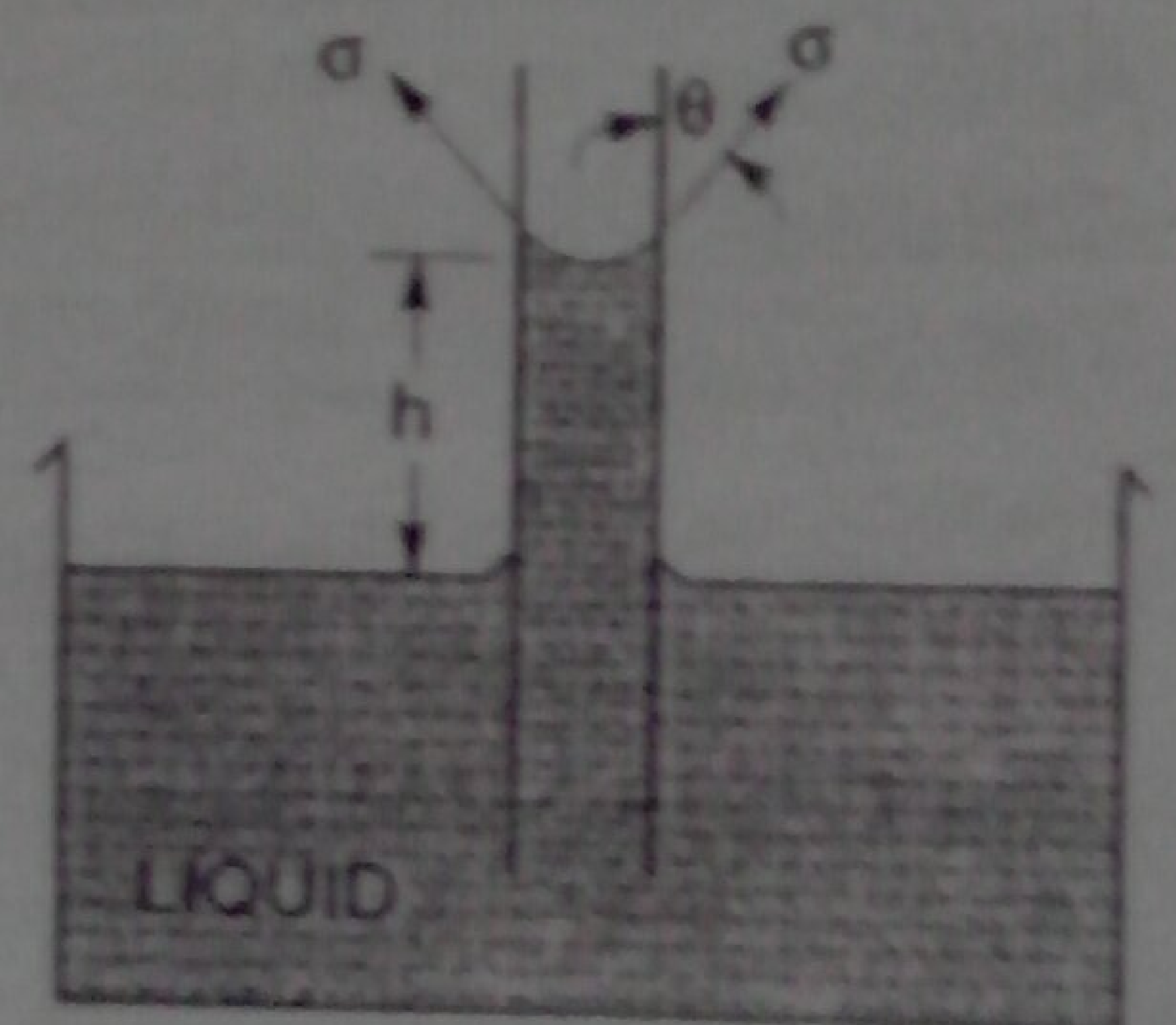

Fig. 1.13 Capillary rise.



$$= \frac{\pi}{4} d^2 \times h \times \rho \times g \quad \dots(1.17)$$

where  $\rho$  = Density of liquid

Vertical component of the surface tensile force

$$= (\sigma \times \text{Circumference}) \times \cos \theta$$

$$= \sigma \times \pi d \times \cos \theta \quad \dots(1.18)$$

For equilibrium, equating (1.17) and (1.18), we get

$$\frac{\pi}{4} d^2 \times h \times \rho \times g = \sigma \times \pi d \times \cos \theta$$

or

$$h = \frac{\sigma \times \pi d \times \cos \theta}{\frac{\pi}{4} d^2 \times \rho \times g} = \frac{4 \sigma \cos \theta}{\rho \times g \times d} \quad \dots(1.19)$$

The value of  $\theta$  between water and clean glass tube is approximately equal to zero and hence  $\cos \theta$  is equal to unity. Then rise of water is given by

$$h = \frac{4 \sigma}{\rho \times g \times d} \quad \dots(1.20)$$

**Expression for Capillary Fall.** If the glass tube is dipped in mercury, the level of mercury in the tube will be lower than the general level of the outside liquid as shown in Fig. 1.14.

Let  $h$  = Height of depression in tube.

Then in equilibrium, two forces are acting on the mercury inside the tube. First one is due to surface tension acting in the downward direction and is equal to  $\sigma \times \pi d \times \cos \theta$ .

Second force is due to hydrostatic force acting upward and is equal to intensity of pressure at a depth ' $h$ '  $\times$  Area

$$= p \times \frac{\pi}{4} d^2 = \rho g \times h \times \frac{\pi}{4} d^2 \quad (\because p = \rho g h)$$

Equating the two, we get

$$\sigma \times \pi d \times \cos \theta = \rho g h \times \frac{\pi}{4} d^2$$

$$\therefore h = \frac{4 \sigma \cos \theta}{\rho g d} \quad \dots(1.21)$$

Value of  $\theta$  for mercury and glass tube is  $128^\circ$ .

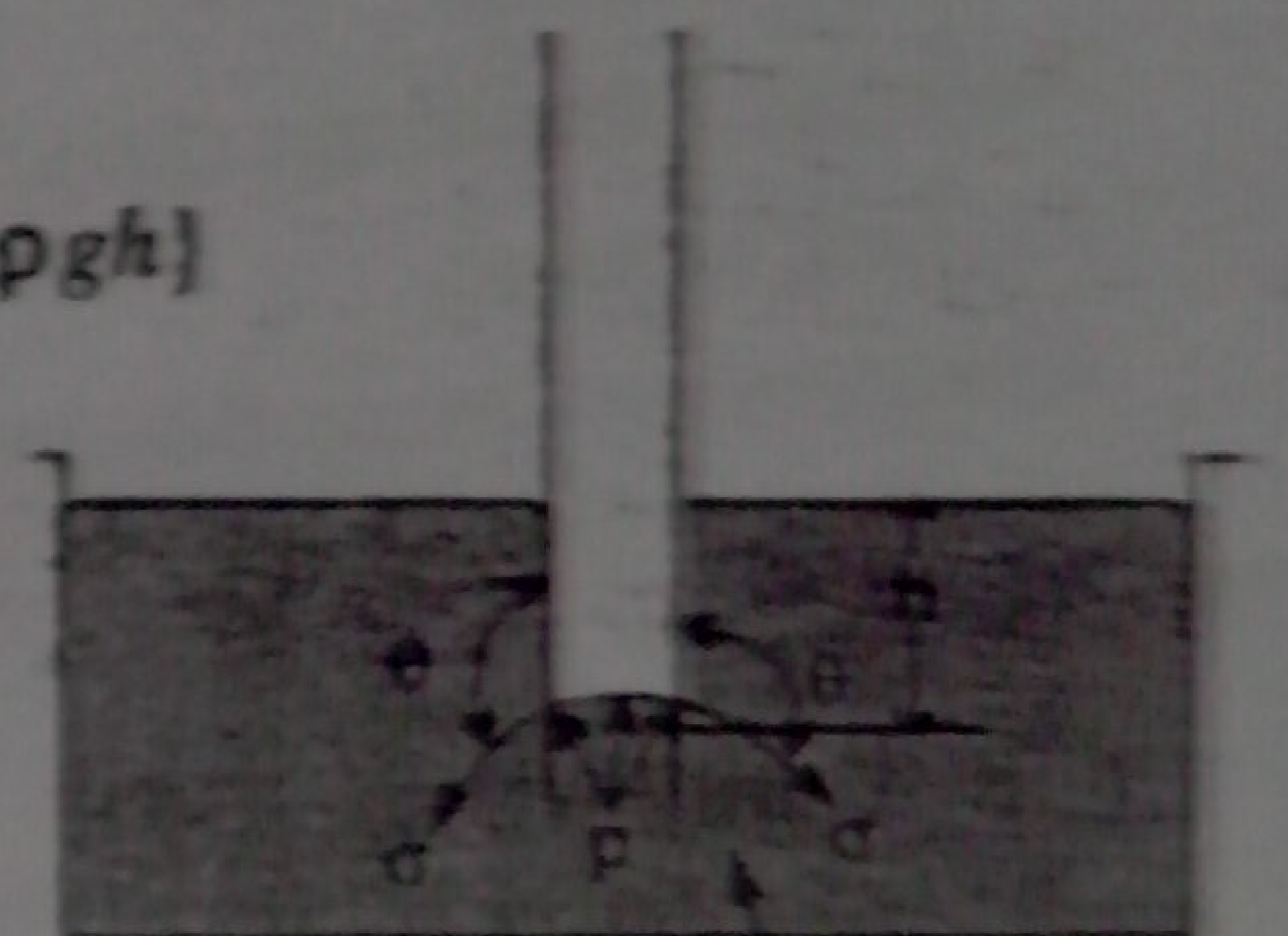

Fig. 1.14

**Problem 1.28** Calculate the capillary rise in a glass tube of 2.5 mm diameter when immersed vertically in (a) water and (b) mercury. Take surface tensions  $\sigma = 0.0725 \text{ N/m}$  for water and  $\sigma = 0.52 \text{ N/m}$  for mercury in contact with air. The specific gravity for mercury is given as 13.6 and angle of contact =  $130^\circ$ .

**Solution.** Given :

Dia. of tube,	$d = 2.5 \text{ mm} = 2.5 \times 10^{-3} \text{ m}$
Surface tension, $\sigma$ for water	$= 0.0725 \text{ N/m}$
$\sigma$ for mercury	$= 0.52 \text{ N/m}$
Sp. gr. of mercury	$= 13.6$



$$\therefore \text{Density} = 13.6 \times 1000 \text{ kg/m}^3.$$

(a) Capillary rise for water ( $\theta = 0^\circ$ )

$$\text{Using equation (1.20), we get } h = \frac{4\sigma}{\rho \times g \times d} = \frac{4 \times 0.0725}{1000 \times 9.81 \times 2.5 \times 10^{-3}}$$

$$= .0118 \text{ m} = 1.18 \text{ cm. Ans.}$$

(b) For mercury

Angle of contact between mercury and glass tube,  $\theta = 130^\circ$

$$\text{Using equation (1.21), we get } h = \frac{4\sigma \cos \theta}{\rho \times g \times d} = \frac{4 \times 0.52 \times \cos 130^\circ}{13.6 \times 1000 \times 9.81 \times 2.5 \times 10^{-3}}$$

$$= -.004 \text{ m} = -0.4 \text{ cm. Ans.}$$

The negative sign indicates the capillary depression.

**Problem 1.29** Calculate the capillary effect in millimetres in a glass tube of 4 mm diameter, when immersed in (i) water, and (ii) mercury. The temperature of the liquid is  $20^\circ\text{C}$  and the values of the surface tension of water and mercury at  $20^\circ\text{C}$  in contact with air are  $0.073575 \text{ N/m}$  and  $0.51 \text{ N/m}$  respectively. The angle of contact for water is zero and that for mercury is  $130^\circ$ . Take density of water at  $20^\circ\text{C}$  as equal to  $998 \text{ kg/m}^3$ .

**Solution.** Given:

$$\text{Dia. of tube, } d = 4 \text{ mm} = 4 \times 10^{-3} \text{ m}$$

The capillary effect (i.e., capillary rise or depression) is given by equation (1.20) as

$$h = \frac{4\sigma \cos \theta}{\rho \times g \times d}$$

where  $\sigma$  = surface tension in N/m

$\theta$  = angle of contact, and  $\rho$  = density

(i) Capillary effect for water

$$\sigma = 0.073575 \text{ N/m, } \theta = 0^\circ$$

$$\rho = 998 \text{ kg/m}^3 \text{ at } 20^\circ\text{C}$$

$$\therefore h = \frac{4 \times 0.073575 \times \cos 0^\circ}{998 \times 9.81 \times 4 \times 10^{-3}} = 7.51 \times 10^{-3} \text{ m} = 7.51 \text{ mm. Ans.}$$

(ii) Capillary effect for mercury

$$\sigma = 0.51 \text{ N/m, } \theta = 130^\circ \text{ and}$$

$$\rho = \text{sp. gr.} \times 1000 = 13.6 \times 1000 = 13600 \text{ kg/m}^3$$

$$\therefore h = \frac{4 \times 0.51 \times \cos 130^\circ}{13600 \times 9.81 \times 4 \times 10^{-3}} = -2.46 \times 10^{-3} \text{ m} = -2.46 \text{ mm. Ans.}$$

The negative sign indicates the capillary depression.

**Problem 1.30** The capillary rise in the glass tube is not to exceed 0.2 mm of water. Determine its minimum size, given that surface tension for water in contact with air =  $0.0725 \text{ N/m}$ .

**Solution.** Given:

$$\text{Capillary rise, } h = 0.2 \text{ mm} = 0.2 \times 10^{-3} \text{ m}$$

$$\text{Surface tension, } \sigma = 0.0725 \text{ N/m}$$



Let dia. of tube  $= d$   
 The angle  $\theta$  for water  $= 0^\circ$   
 Density ( $\rho$ ) for water  $= 1000 \text{ kg/m}^3$

Using equation (1.20), we get

$$h = \frac{4\sigma}{\rho \times g \times d} \text{ or } 0.2 \times 10^{-3} = \frac{4 \times 0.0725}{1000 \times 9.81 \times d}$$

$$\therefore d = \frac{4 \times 0.0725}{1000 \times 9.81 \times 2 \times 10^{-3}} = 0.148 \text{ m} = 14.8 \text{ cm. Ans.}$$

Thus minimum diameter of the tube should be 14.8 cm.

**Problem 1.31** Find out the minimum size of glass tube that can be used to measure water level if the capillary rise in the tube is to be restricted to 2 mm. Consider surface tension of water in contact with air as 0.073575 N/m.

**Solution.** Given :

Capillary rise,  $h = 2.0 \text{ mm} = 2.0 \times 10^{-3} \text{ m}$

Surface tension,  $\sigma = 0.073575 \text{ N/m}$

Let dia. of tube  $= d$

The angle  $\theta$  for water  $= 0^\circ$

The density for water,  $\rho = 1000 \text{ kg/m}^3$

Using equation (1.20), we get

$$h = \frac{4\sigma}{\rho \times g \times d} \text{ or } 2.0 \times 10^{-3} = \frac{4 \times 0.073575}{1000 \times 9.81 \times d}$$

$$\therefore d = \frac{4 \times 0.073575}{1000 \times 9.81 \times 2 \times 10^{-3}} = 0.015 \text{ m} = 1.5 \text{ cm. Ans.}$$

Thus minimum diameter of the tube should be 1.5 cm.

**Problem 1.32** An oil of viscosity 5 poise is used for lubrication between a shaft and sleeve. The diameter of the shaft is 0.5 m and it rotates at 200 r.p.m. Calculate the power lost in oil for a sleeve length of 100 mm. The thickness of oil film is 1.0 mm.

**Solution.** Given :

Viscosity,  $\mu = 5 \text{ poise}$

$$= \frac{5}{10} = 0.5 \text{ N s/m}^2$$

Dia. of shaft,  $D = 0.5 \text{ m}$

Speed of shaft,  $N = 200 \text{ r.p.m.}$

Sleeve length,  $L = 100 \text{ mm} = 100 \times 10^{-3} \text{ m} = 0.1 \text{ m}$

Thickness of oil film,  $t = 1.0 \text{ mm} = 1 \times 10^{-3} \text{ m}$

$$\text{Tangential velocity of shaft, } u = \frac{\pi DN}{60} = \frac{\pi \times 0.5 \times 200}{60} = 5.235 \text{ m/s}$$

$$\text{Using the relation, } \tau = \mu \frac{du}{dy}$$



where,  $du = \text{Change of velocity} = u - 0 = u = 5.235 \text{ m/s}$

$dy = \text{Change of distance} = r = 1 \times 10^{-3} \text{ m}$

$$\tau = \frac{0.5 \times 5.235}{1 \times 10^{-3}} = 2617.5 \text{ N/m}^2$$

This is the shear stress on the shaft

$$\begin{aligned} \therefore \text{Shear force on the shaft, } F &= \text{Shear stress} \times \text{Area} = 2617.5 \times \pi D \times L \quad (\because \text{Area} = \pi D \times L) \\ &= 2617.5 \times \pi \times 0.5 \times 0.1 = 410.95 \text{ N} \end{aligned}$$

$$\text{Torque on the shaft, } T = \text{Force} \times \frac{D}{2} = 410.95 \times \frac{0.5}{2} = 102.74 \text{ Nm}$$

$$\begin{aligned} \therefore \text{Power* lost} &= T \times \omega \text{ Watts} = T \times \frac{2\pi N}{60} \text{ W} \\ &= 102.74 \times \frac{2\pi \times 200}{60} = 2150 \text{ W} = 2.15 \text{ kW, Ans.} \end{aligned}$$

## ► 1.7 VAPOUR PRESSURE AND CAVITATION

A change from the liquid state to the gaseous state is known as vaporization. The vaporization (which depends upon the prevailing pressure and temperature condition) occurs because of continuous escaping of the molecules through the free liquid surface.

Consider a liquid (say water) which is confined in a closed vessel. Let the temperature of liquid is  $20^\circ\text{C}$  and pressure is atmospheric. This liquid will vaporise at  $100^\circ\text{C}$ . When vaporization takes place, the molecules escapes from the free surface of the liquid. These vapour molecules get accumulated in the space between the free liquid surface and top of the vessel. These accumulated vapours exert a pressure on the liquid surface. This pressure is known as vapour pressure of the liquid or this is the pressure at which the liquid is converted into vapours.

Again consider the same liquid at  $20^\circ\text{C}$  at atmospheric pressure in the closed vessel. If the pressure above the liquid surface is reduced by some means, the boiling temperature will also reduce. If the pressure is reduced to such an extent that it becomes equal to or less than the vapour pressure, the boiling of the liquid will start, though the temperature of the liquid is  $20^\circ\text{C}$ . Thus a liquid may boil even at ordinary temperature, if the pressure above the liquid surface is reduced so as to be equal or less than the vapour pressure of the liquid at that temperature.

Now consider a flowing liquid in a system. If the pressure at any point in this flowing liquid becomes equal to or less than the vapour pressure, the vaporization of the liquid starts. The bubbles of these vapours are carried by the flowing liquid into the region of high pressure where they collapse, giving rise to high impact pressure. The pressure developed by the collapsing bubbles is so high that the material from the adjoining boundaries gets eroded and cavities are formed on them. This phenomenon is known as cavitation.

Hence the cavitation is the phenomenon of formation of vapour bubbles of a flowing liquid in a region where the pressure of the liquid falls below the vapour pressure and sudden collapsing of these vapour bubbles in a region of higher pressure. When the vapour bubbles collapse, a very high pressure is created. The metallic surfaces, above which the liquid is flowing, is subjected to these high pressures, which cause pitting action on the surface. Thus cavities are formed on the metallic surface and hence the name is cavitation.

\* Power in case of S.I. Unit =  $T \times \omega$  or  $\frac{2\pi NT}{60}$  Watts or  $\frac{2\pi NT}{60,000}$  kW. The angular velocity  $\omega = \frac{2\pi N}{60}$



## HIGHLIGHTS

1. The weight density or specific weight of a fluid is equal to weight per unit volume. It is also equal to,
 
$$w = \rho \times g.$$
2. Specific volume is the reciprocal of mass density.
3. The shear stress is proportional to the velocity gradient  $\frac{du}{dy}$ . Mathematically,  $\tau = \mu \frac{du}{dy}$ .
4. Kinematic viscosity  $\nu$  is given by  $\nu = \frac{\mu}{\rho}$ .
5. Poise and stokes are the units of viscosity and kinematic viscosity respectively.
6. To convert the unit of viscosity from poise to MKS units, poise should be divided by 98 J and to convert poise into SI units, the poise should be divided by 10. SI unit of viscosity is  $\text{Ns/m}^2$  or Pa s, where  $\text{Ns/m}^2 = \text{Pa} = \text{Pascal}$ .
7. For a perfect gas, the equation of state is  $\frac{p}{\rho} = RT$ 

where  $R = \text{gas constant and for air} = 29.3 \frac{\text{kgf-m}}{\text{kg}^\circ\text{K}} = 287 \text{ J/kg}^\circ\text{K}$ .
8. For isothermal process,  $\frac{p}{\rho} = \text{Constant}$  whereas for adiabatic process,  $\frac{p}{\rho^\gamma} = \text{constant}$ .
9. Bulk modulus of elasticity is given as  $K = \frac{-dp}{\left(\frac{dV}{V}\right)}$ .
10. Compressibility is the reciprocal of bulk modulus of elasticity  $\alpha = \frac{1}{K}$ .
11. Surface tension is expressed in  $\text{Nm}$  or  $\text{dyn/cm}$ . The relation between surface tension ( $\sigma$ ) and difference of pressure ( $p$ ) between the inside and outside of a liquid drop is given as  $p = \frac{4\sigma}{r}$ .
 

For a soap bubble,  $p = \frac{8\sigma}{r}$

For a liquid jet,  $p = \frac{2\sigma}{r}$
12. Capillary rise or fall of a liquid is given by  $h = \frac{4\sigma \cos \theta}{wd}$ .
 

The value of  $\theta$  for water is taken equal to zero and for mercury equal to  $128^\circ$ .

## EXERCISE

### (A) THEORETICAL PROBLEMS

1. Define the following fluid properties :  
Density, weight density, specific volume and specific gravity of a fluid.
2. Differentiate between : (i) Liquids and gases, (ii) Real fluids and ideal fluids, (iii) Specific weight and specific volume of a fluid.
3. What is the difference between dynamic viscosity and kinematic viscosity ? State their units of measurements.



4. Explain the terms : (i) Dynamic viscosity, and (ii) Kinematic viscosity. Give their dimensions.
5. State the Newton's law of viscosity and give examples of its application.
6. Enunciate Newton's law of viscosity. Explain the importance of viscosity in fluid motion. What is the effect of temperature on viscosity of water and that of air?
7. Define Newtonian and Non-Newtonian fluids.
8. What do you understand by terms : (i) Isothermal process, (ii) Adiabatic process, and (iii) Universal gas constant.
9. Define compressibility. Prove that compressibility for a perfect gas undergoing isothermal compression is  $\frac{1}{p}$  while for a perfect gas undergoing isentropic compression is  $\frac{1}{\gamma p}$ .
10. Define surface tension. Prove that the relationship between surface tension and pressure inside a droplet of liquid in excess of outside pressure is given by  $p = \frac{4\sigma}{d}$ .
11. Explain the phenomenon of capillarity. Obtain an expression for capillary rise of a liquid.
12. (a) Distinguish between ideal fluids and real fluids. Explain the importance of compressibility in fluid flow.  
(b) Define the terms : density, specific volume, specific gravity, vacuum pressure, compressible and incompressible fluids. (R.G.P. Vishwavidyalaya, Bhopal S 2002)
13. Define and explain Newton's law of viscosity.
14. Convert 1 kg/s-m dynamic viscosity in poise.
15. Why does the viscosity of a gas increases with the increase in temperature while that of a liquid decreases with increase in temperature ?
16. (a) How does viscosity of a fluid vary with temperature ?  
(b) Cite examples where surface tension effects play a prominent role. (J.N.T.U., Hyderabad S 2002)
17. (i) Develop the expression for the relation between gauge pressure  $P$  inside a droplet of liquid and the surface tension.  
(ii) Explain the following :  
- Newtonian and Non-Newtonian fluids, vapour pressure, and compressibility. (R.G.P.V., Bhopal S 2001)

### (B) NUMERICAL PROBLEMS

1. One litre of crude oil weighs 9.6 N. Calculate its specific weight, density and specific gravity. [Ans. 9600 N/m<sup>3</sup>, 978.6 kg/m<sup>3</sup>, 0.978]
2. The velocity distribution for flow over a flat plate is given by  $u = \frac{3}{2} y - y^{3/2}$ , where  $u$  is the point velocity in metre per second at a distance  $y$  metre above the plate. Determine the shear stress at  $y = 9$  cm. Assume dynamic viscosity as 8 poise. (Nagpur University) [Ans. 0.839 N/m<sup>2</sup>]
3. A plate 0.025 mm distant from a fixed plate, moves at 50 cm/s and requires a force of 1.471 N/m<sup>2</sup> to maintain this speed. Determine the fluid viscosity between the plates in the poise. [Ans. 7.357 × 10<sup>-4</sup>]
4. Determine the intensity of shear of an oil having viscosity = 1.2 poise and is used for lubrication in the clearance between a 10 cm diameter shaft and its journal bearing. The clearance is 1.0 mm and shaft rotates at 200 r.p.m. [Ans. 125.56 N/m<sup>2</sup>]
5. Two plates are placed at a distance of 0.15 mm apart. The lower plate is fixed while the upper plate having surface area 1.0 m<sup>2</sup> is pulled at 0.3 m/s. Find the force and power required to maintain this speed, if the fluid separating them is having viscosity 1.5 poise. [Ans. 300 N, 89.8 W]
6. An oil film of thickness 1.5 mm is used for lubrication between a square plate of size 0.9 m × 0.9 m and an inclined plane having an angle of inclination 20°. The weight of the square is 392.4 N and it slides down the plane with a uniform velocity of 0.2 m/s. Find the dynamic viscosity of the oil. [Ans. 12.42 poise]



7. In a stream of glycerine in motion, at a certain point the velocity gradient is 0.25 metre per sec per metre. The mass density of fluid is 1268.4 kg per cubic metre and kinematic viscosity is  $6.30 \times 10^{-4}$  square metre per second. Calculate the shear stress at the point. [Ans. 0.2 N/m<sup>2</sup>]
8. Find the kinematic viscosity of an oil having density 980 kg/m<sup>3</sup> when at a certain point in the oil, the shear stress is 0.25 N/m<sup>2</sup> and velocity gradient is 0.3/s. [Ans.  $0.000849 \frac{\text{m}^2}{\text{sec}}$  or 8.49 stokes]
9. Determine the specific gravity of a fluid having viscosity 0.07 poise and kinematic viscosity 0.042 stokes. [Ans. 1.667]
10. Determine the viscosity of a liquid having kinematic viscosity 6 stokes and specific gravity 2.0. [Ans. 11.99 poise]
11. If the velocity distribution of a fluid over a plate is given by  $u = (3/4)y - y^2$ , where  $u$  is the velocity in metre per second at a distance of  $y$  metres above the plate, determine the shear stress at  $y = 0.15$  metre. Take dynamic viscosity of the fluid as  $8.5 \times 10^{-5}$  kg-sec/m<sup>2</sup>. [Ans.  $3.825 \times 10^{-5}$  kg/cm<sup>2</sup>]
12. An oil of viscosity 5 poise is used for lubrication between a shaft and sleeve. The diameter of shaft is 0.5 m and it rotates at 200 r.p.m. Calculate the power lost in the oil for a sleeve length of 100 mm. The thickness of the oil film is 1.0 mm. [Ans. 2.15 kW]
13. The velocity distribution over a plate is given by  $u = \frac{2}{3}y - y^2$  in which  $u$  is the velocity in m/sec at a distance of  $y$  m above the plate. Determine the shear stress at  $y = 0, 0.1$  and  $0.2$  m. Take  $\mu = 6$  poise. [Ans. 0.4, 0.028 and 0.159 N/m<sup>2</sup>]
14. In question 13, find the distance in metres above the plate, at which the shear stress is zero. [Ans. 0.333 m]
15. The velocity profile of a viscous fluid over a plate is parabolic with vertex 20 cm from the plate, where the velocity is 120 cm/s. Calculate the velocity gradient and shear stress at distances of 0, 5 and 15 cm from the plate, given the viscosity of the fluid = 6 poise. [Ans. 12/s, 7.18 N/m<sup>2</sup>; 9/s, 5.385 N/m<sup>2</sup>; 3/s, 1.795 N/m<sup>2</sup>]
16. The weight of a gas is given as 17.658 N/m<sup>3</sup> at 30°C and at an absolute pressure of 29.43 N/cm<sup>2</sup>. Determine the gas constant and also the density of the gas. [Ans.  $\frac{1.8 \text{ kg}}{\text{m}^3}, \frac{539.55 \text{ N m}}{\text{kg}^2 \text{K}}$ ]
17. A cylinder of 0.9 m<sup>3</sup> in volume contains air at 0°C and 39.24 N/cm<sup>2</sup> absolute pressure. The air is compressed to 0.45 m<sup>3</sup>. Find (i) the pressure inside the cylinder assuming isothermal process, (ii) pressure and temperature assuming adiabatic process. Take  $k = 1.4$  for air. [Ans. (i) 78.48 N/cm<sup>2</sup>, (ii) 103.5 N/m<sup>2</sup>, 140°C]
18. Calculate the pressure exerted by 4 kg mass of nitrogen gas at a temperature of 15°C if the volume is 0.35 m<sup>3</sup>. Molecular weight of nitrogen is 28. [Ans. 97.8 N/cm<sup>2</sup>]
19. The pressure of a liquid is increased from 60 N/cm<sup>2</sup> to 100 N/cm<sup>2</sup> and volume decreases by 0.2 per cent. Determine the bulk modulus of elasticity. [Ans.  $2 \times 10^4$  N/cm<sup>2</sup>]
20. Determine the bulk modulus of elasticity of a fluid which is compressed in a cylinder from a volume of 0.009 m<sup>3</sup> at 70 N/cm<sup>2</sup> pressure to a volume of 0.0085 m<sup>3</sup> at 270 N/cm<sup>2</sup> pressure. [Ans.  $3.6 \times 10^3$  N/cm<sup>2</sup>]
21. The surface tension of water in contact with air at 20°C is given as 0.0716 N/m. The pressure inside a droplet of water is to be 0.0147 N/cm<sup>2</sup> greater than the outside pressure, calculate the diameter of the droplet of water. [Ans. 1.94 mm]
22. Find the surface tension in a soap bubble of 30 mm diameter when the inside pressure is 1.962 N/m<sup>2</sup> above atmosphere. [Ans. 0.00735 N/m]
23. The surface tension of water in contact with air is given as 0.0725 N/m. The pressure outside the droplet of water of diameter 0.02 mm is atmospheric ( $10.32 \frac{\text{N}}{\text{cm}^2}$ ). Calculate the pressure within the droplet of water. [Ans. 11.77 N/cm<sup>2</sup>]



24. Calculate the capillary rise in a glass tube of 3.0 mm diameter when immersed vertically in (a) water, and (b) mercury. Take surface tensions for mercury and water as 0.0725 N/m and 0.52 N/m respectively in contact with air. Specific gravity for mercury is given as 13.6. [Ans. 0.966 cm, 0.3275 cm]
25. The capillary rise in the glass tube used for measuring water level is not to exceed 0.5 mm. Determine its minimum size, given that surface tension for water in contact with air = 0.07112 N/m. [Ans. 5.8 cm]
26. (SI Units). One litre of crude oil weighs 9.6 N. Calculate its specific weight, density and specific gravity. [Ans. 9600 N/m<sup>3</sup>; 979.6 kg/m<sup>3</sup>; 0.9786]
27. (SI Units). A piston 796 mm diameter and 200 mm long works in a cylinder of 800 mm diameter. If the annular space is filled with a lubricating oil of viscosity 5 cp (centi-poise), calculate the speed of descent of the piston in vertical position. The weight of the piston and axial load are 9.81 N. [Ans. 7.84 m/s]
28. (SI Units). Find the capillary rise of water in a tube 0.03 cm diameter. The surface tension of water is 0.0735 N/m. [Ans. 9.99 cm]
29. Calculate the specific weight, density and specific gravity of two litres of a liquid which weight 15 N. [Ans. 7500 N/m<sup>3</sup>, 764.5 kg/m<sup>3</sup>, 0.764]
30. A 150 mm diameter vertical cylinder rotates concentrically inside another cylinder of diameter 151 mm. Both the cylinders are of 250 mm height. The space between the cylinders is filled with a liquid of viscosity 10 poise. Determine the torque required to rotate the inner cylinder at 100 r.p.m. [Ans. 13.87 Nm]
31. A shaft of diameter 120 mm is rotating inside a journal bearing of diameter 122 mm at a speed of 360 r.p.m. The space between the shaft and the bearing is filled with a lubricating oil of viscosity 6 poise. Find the power absorbed in oil if the length of bearing is 100 mm. [Ans. 115.73 W]
32. A shaft of diameter 100 mm is rotating inside a journal bearing of diameter 102 mm at a space of 360 r.p.m. The space between the shaft and bearing is filled with a lubricating oil of viscosity 5 poise. The length of the bearing is 200 mm. Find the power absorbed in the lubricating oil. [Ans. 111.58 W]
33. Assuming that the bulk modulus of elasticity of water is  $2.07 \times 10^6$  kN/m<sup>2</sup> at standard atmospheric conditions, determine the increase of pressure necessary to produce 1% reduction in volume at the same temperature.

$$\text{Hint. } K = 2.07 \times 10^6 \text{ kN/m}^2; \frac{-dV}{V} = \frac{1}{100} = 0.01$$

$$\text{Increase in pressure } (dp) = K \times \left( \frac{-dV}{V} \right) = 2.07 \times 10^6 \times 0.01 = 2.07 \times 10^4 \text{ kN/m}^2$$

34. A square plate of size 1 m × 1 m and weighing 350 N slides down an inclined plane with a uniform velocity of 1.5 m/s. The inclined plane is laid on a slope of 5 vertical to 12 horizontal and has an oil film of 1 mm thickness. Calculate the dynamic viscosity of oil. [J.N.T.U., Hyderabad, S 2002]

$$\text{[Hint. } A = 1 \times 1 = 1 \text{ m}^2, W = 350 \text{ N, } u = 1.5 \text{ m/s, } \tan \theta = \frac{5}{12} = \frac{BC}{AB}$$

$$\text{Component of weight along the plane} = W \times \sin \theta$$

$$\text{where } \sin \theta = \frac{BC}{AC} = \frac{5}{13} \quad \left( \begin{array}{l} \because AC = \sqrt{AB^2 + BC^2} \\ = \sqrt{12^2 + 5^2} = 13 \end{array} \right)$$

$$\therefore F = W \sin \theta = 350 \times \frac{5}{13} = 134.615$$

$$\text{Now } \tau = \mu \frac{du}{dy}, \text{ where } du = u - 0 = u = 1.5 \text{ m/s and } dy = 1 \text{ mm} = 1 \times 10^{-3} \text{ m}$$

$$\text{or } \frac{F}{A} = \mu \frac{du}{dy}, \therefore \mu = \frac{F}{A} \times \frac{dy}{du} = \frac{134.615}{1} \times \frac{1 \times 10^{-3}}{1.5} = 0.0897 \frac{\text{Ns}}{\text{m}^2} = 0.897 \text{ poise}]$$

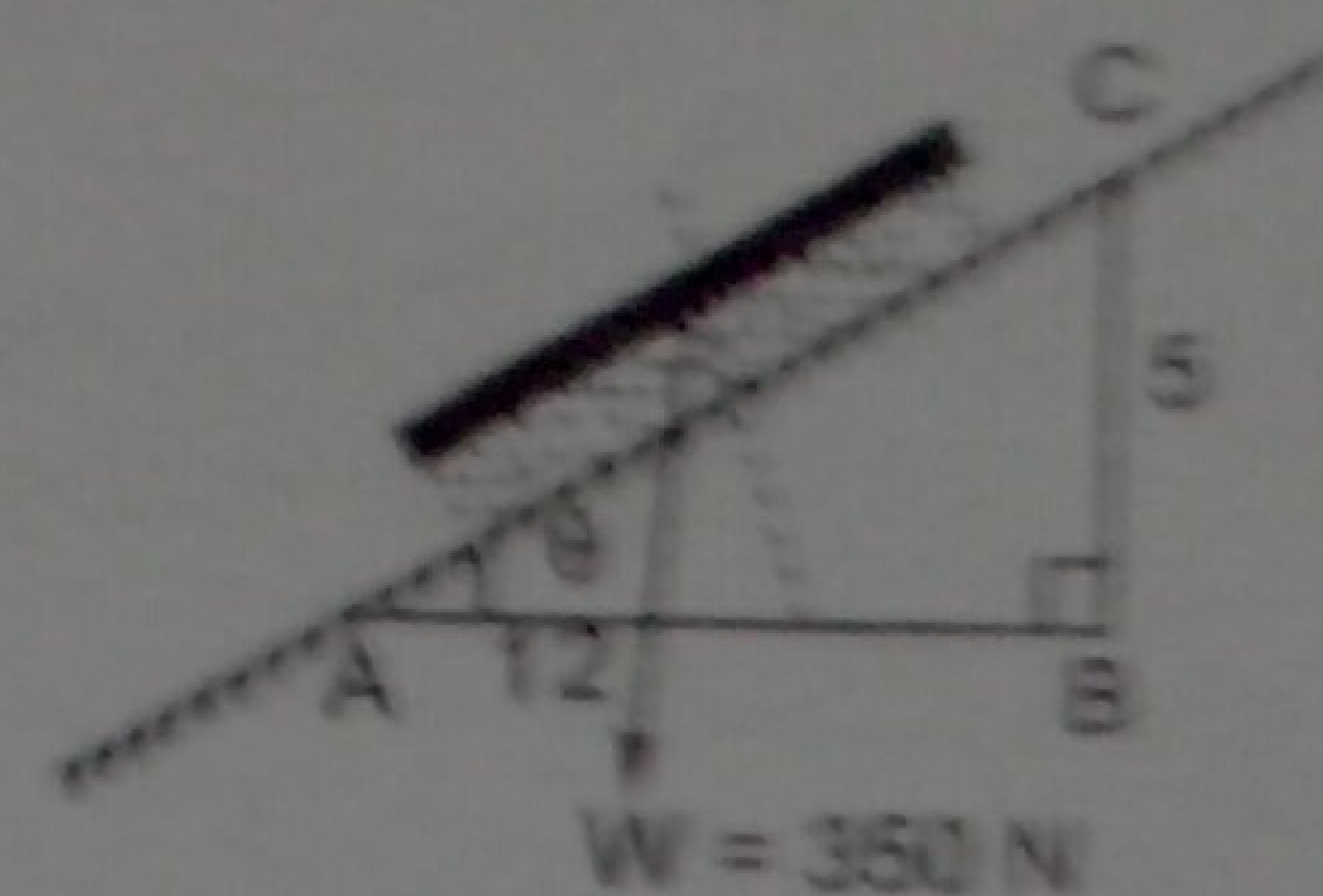

Fig. 1.15