

# Heliosa 9.3 Waterproof Heater

## 9/3S20BTW - Bluetooth control & white glass



WHITE SCREEN GLASS  
<100 LUX



#### With the APP, you can:

- Turn the heater on and off
- Gradually adjust the power from 0 to 100% on each heater or simultaneously all heaters connected to the transmitter operating area
- Manage up to 15 heaters
- Customise the heater profiles and set a password
- Set sleep timer

## SPECIFICATIONS

Power	2000 Watts
Heated area	20-25 m <sup>2</sup>
Net weight	3.45 kg
Gross weight	4.50 kg
Warranty	2 year Parts 1 year Labour (Asset must be registered to activate full warranty)

## DIMENSIONS

External Width	540
External Height	195
External Depth	120

## Main Features

- Heats up to 20-25 square metres
- IPX5 waterproof
- Silver colour
- Thermoresistant front glass
- Reflective aluminum reflector
- Power cable length 5 metres
- Suitable for both inside and outside areas
- Bluetooth control via smartphone app
- Remote control



THE GOOD LADY

Phone: 1800 183 818 | Email: support@thegoodlady.com.au  
Website: www.thegoodlady.com.au

## FRONT

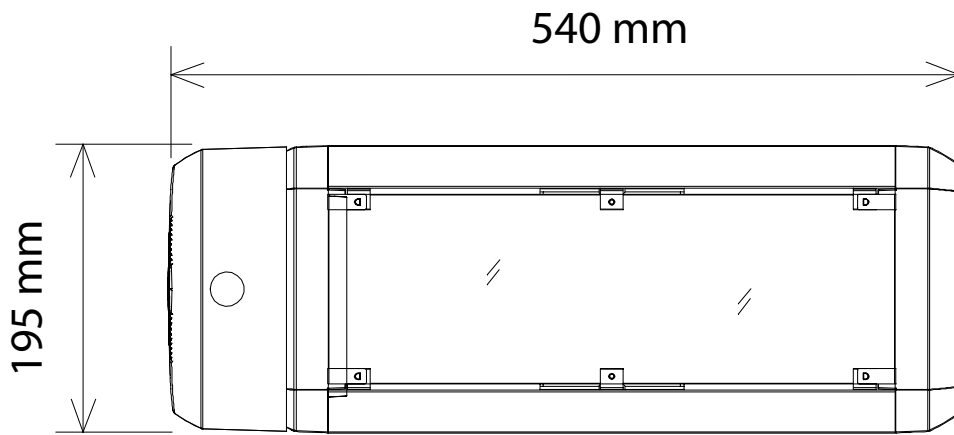

## SIDE

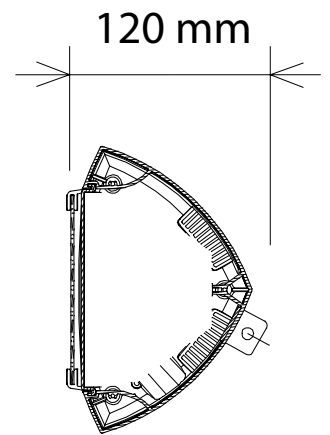

## TOP

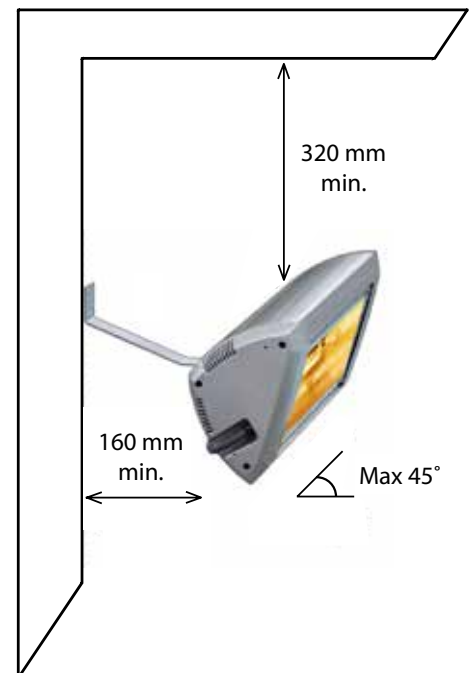
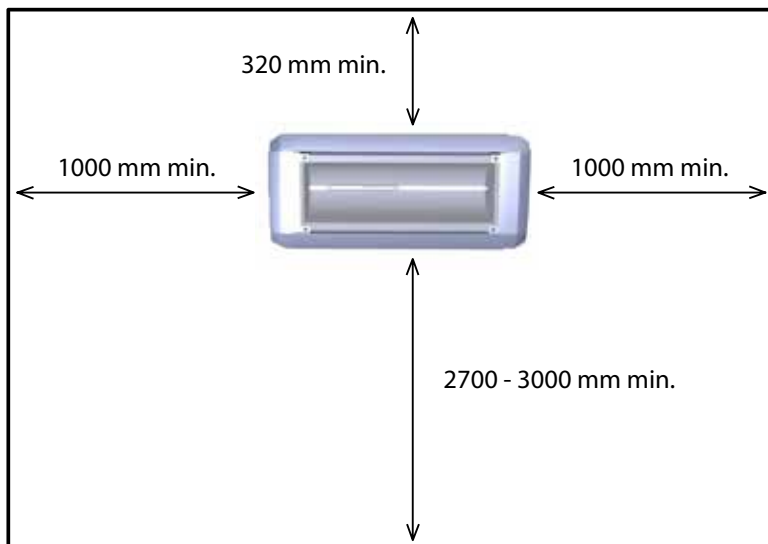
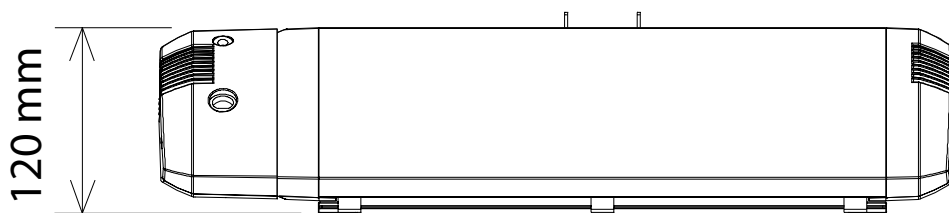

### WALL INSTALLATION

Heliosa must be placed perfectly horizontal and outside distances as above.

We reserve the right to alter specifications without notice.