

## **1 Chemical products** P. 3

- Personal hygiene
- Unblocking and lubricants
- Bonding and repair
- Silicones and sealants
- Protective paints and polishing
- Engine maintenance
- Cleaning and maintenance vehicles
- Motorcycle line
- Anaerobic products Meccanocar
- Loctite and Molykote products
- Accessories for chemical products

## **3 Electrical parts** P. 277

- Wirings
- Fuses and fuse holders
- Connectors
- Terminals and lugs
- Clamps
- Insulating sheaths and electrical cables
- Lamps for motor vehicles and work lights
- Lamps for civil and industrial use
- Battery

## **5 Generic and specific fixing** P. 557

- Nylon fixing
- Fixing in steel and stainless steel
- Chemical anchors and accessories
- Nail guns and nailers
- Fixings for pipes and thermohydraulics
- Air conditioning brackets
- Accessories for frames
- Accessories for doors and gates

## **7 Car, cargo and civil air conditioning** P. 721

- Seals and connections
- Tools climate
- Chemical products

## **2 Metallic hardware and screw** P. 169

- Bolts and nuts
- Grub screws, threaded rods, studs
- Washers
- Self-drilling and self-tapping screws
- Hooks, eye bolts, generic fasteners, seals and O'ring
- Rivets, threaded inserts, tools for rivet
- Plastic and metal hose clamp
- Oil sump plugs
- Traction springs
- Threads filmecc, self tapping bushings

## **4 Taglio, foratura e abrasivi** P. 425

- Lame per macchine fisse e portatili
- Lame per seghetti a mano
- Punte pantografo e frese in HSS
- Punte per trapani e martelli elettropneumatici
- Frese a tazza in HSS e bimetalliche
- Maschi, filiere, svasatori, punte coniche e a gradino
- Taglio e foratura al diamante
- Cutter, coltelli raschietti
- Dischi da taglio e smeriglio
- Dischi lamellari, tele e carte abrasive
- Spazzole in acciaio a macchina e a mano
- Dischi velcrati e tamponi per lucidatura
- Dischi per decapaggio
- Lime

## **6 Consumables** P. 651

- Brushes and brushes
- Insulating and packaging tapes
- Masking systems
- Cloths, sponges and general cleaning
- Filters and fuel pipes
- Lifting and anchoring systems

## **8 Manual gear** P. 729

- Wrenches
- Compasses and accessories
- Screwdrivers
- Inserts hexagonal
- Pliers
- Pipe cutters
- Hammers and chisels
- Thermoformed
- Terminals and extractors
- Tools for building
- Phasing kit
- Specific tooling for bodywork and workshop
- Filter wrenches
- Oilers, lubricators, air operated pumps and oil extractors
- Control and measurement instruments
- Cans, funnels and gatherers

## **9 Electric and pneumatic tools** P. 1059

---

Piping and hose reels  
Compressed air fittings  
Compressors  
Pneumatic tools  
Battery-powered electric tools  
Tools wire electric  
Accessories for electric tools  
Workshop lamps and electric winders  
Starters and battery chargers

## **11 Antinfortunistica** P. 1333

---

Guanti  
Protezioni da cantiere e officina  
Pronto soccorso  
Segnaletica di sicurezza

## **10 Furniture workshop and equipping vans** P. 1245

---

Carts e toolholders  
Workshop furniture  
Van equipment  
Easel and motorcycle lift  
Lifting and transport systems  
Ladders and scaffolding

## **12 Molletteria auto, tergicristallo e tappeti auto** P. 1395

---

Fixings for plate holder  
Plastic nuts  
Special plastic cable ties  
Fixings to lock rod and door  
Fixings wires and cables  
Fixings finishes and internal profiles  
Generic fixings  
Generic fixings external body  
Fixings guides of the side windows  
Fixings exterior moldings  
Fixing for Bumper and Fenders  
Fixing for windscreen  
Fixing for wheel arches  
Fixing for upholstery  
Fissaggi per targhette modello  
Fixing for radiators  
Fixing for carpets  
Fixing for car doors  
Screws fixing plate  
Plastic rivets  
Capping caps  
Special screws and rivets  
Assortments  
Windscreen wiper  
Car carpets

## **13 Truck** P. 1505

---

Tachograph systems  
Signage  
Accident prevention and ADR  
Outdoor accessories  
Interior accessories  
Spirals, joints and pipes  
Fittings for braking and diesel systems  
Fissaggio per teloni  
Electrical equipment for vehicles

## **14 Tire service** P. 1625

---

Balancing weights  
Tubeless valves  
Tools for tire specialists  
TPMS System

## **15 Welding** P. 1661

---

Ossigas welding  
Electrode welding and TIG  
Wire welding  
Plasma cutting  
Tin welding  
Consumables for Spotter  
Personal protection





## Chemical products

Personal hygiene .....	pag. 4	Cleaning and maintenance vehicles .....	pag. 117
Unblocking and lubricants .....	pag. 9	Motorcycle line .....	pag. 144
Bonding and repair .....	pag. 27	Anaerobic products Meccanocar.....	pag. 147
Silicones and sealants .....	pag. 47	Loctite and Molykote products.....	pag. 150
Protective paints and polishing.....	pag. 69	Accessories for chemical products .....	pag. 160
Engine maintenance.....	pag. 97		

## Hand-wash white pulp



- Solid hand-wash pulp, very delicate, containing no mineral abrasives, made up with natural soaps and synthetic micrograins.
- Ideal for the removal of all industrial dirt from hands, like greases - also hardened ones, oils, products for car bodies, paints and inks.
- The particular formula, biodegradable over 90%, doesn't block pipings, not even if used in high quantities.
- **TECHNICAL DATA:**
- Colour: white.
- Perfume: lemon.
- PH: 7+/-0,1.
- Chemical-physical appearance: semisolid pulp.

Code	Desc.	Content
4110015430	3025	4 L.
4110019870	6290	20 kg

## Hand-wash fluid pulp



- Hand-wash cream with innovating formula, neutral also on the most delicate skins, lightly abrasive, based only on natural essences.
- Very good to eliminate any kind of industrial and persistent dirt like greases, dirt, oils, etc.
- Thanks to the absence of solvents and mineral abrasives, the results got are those of a very good washing, absolute respect of the skin and minimum ecological impact.
- Basically supplied with a supplying pump per can.
- **TECHNICAL DATA:**
- Colour: white.
- Perfume: characteristic.
- PH: 6,5/7,5.
- Chemical-physical appearance: creamy.

Code	Desc.	Content lt
4110015440	3030	3

## Fluid paste washstand Eco-recharge two-liter



- The eco-recharge handwashing paste fluid retains the excellent characteristics of the product in the tank, reduces the waste of useless plastic and saves product with an improved controlled the special dispenser wall professional.
- Each spray is precise and dosed for the cleaning of the hands of an operator.

Code	Desc.	Cont. Lt
4110019710	6215	2

## Hand-wash gel



- Delicate hand-wash, gel formula based on citrus fruits with synthetic micrograins.
- Produced only with natural solvents, neutral on any kind of skin.
- High degreasing power. suitable for all kinds of industrial dirt like greases - also hardened ones, oils, mechanical dirt, car shop dirt, etc.
- Basically supplied with a supplying pump per can.
- **TECHNICAL DATA:**
- Colour: orange.
- Perfume: orange.
- PH: 7+/-0,1.
- Chemical-physical appearance: gel.

Code	Desc.	Content It
4110015450	3035	3

## Hand cleaning gel Ecoricarica two liters



- The ecoricarica handwashing gel retains the excellent characteristics of the product in the tank, reduces the waste of useless plastic and saves product with an improved controlled the special dispenser wall professional.
- Each spray is precise and dosed for the cleaning of the hands of an operator.

Code	Desc.	Cont. Lt
4110019720	6220	2

## Hand-wash gel for paints



- Hand-wash gel based on citrus fruits with synthetic micrograins.
- Specific formula studied for the elimination of very difficult dirt. Suitable for the cleaning from paints, inks, adhesive, even dry.
- Absolutely devoid of solvents, neutral on any kind of skin.
- It contains natural active substances extracted from citrus fruits.
- Basically supplied with a supplying pump per can.
- **TECHNICAL DATA:**
- Colour: whitish.
- Perfume: orange.
- PH: 7/8.
- Chemical-physical appearance: gel.

Code	Desc.	Content It
4110015460	3040	3



## Hand cleaning gel for paints Ecoricarica two liters



- The ecoricarica gel hand washing paint maintains the excellent characteristics of the product in the tank, allows considerable savings on the packaging, decreases waste of useless plastic and saves product with an improved controlled the special dispenser wall professional.
- Each spray is precise and dosed for the cleaning of the hands of an operator.

Code	Desc.	Cont. Lt
4110019730	6225	2

## Professional pump for washstand



- Professional pump for use with hand-washing pastes and fluid gel hand washing of all types.
- Shockproof plastic housing, internal mechanism entirely of steel, aluminum spout. Very long service life even with use with highly abrasive and dense. Possibility 'of easy disassembly for cleaning eventuale residue dry cleaners.
- Diameter of the threaded fastener: 22.5 mm. Depth 'of draft: minimum 14 cm, maximum 28 cm.

Code	Desc.
4110019415	6050

## Dispenser wall ecoricariche



- Dispenser wall professional ecoricariche Meccanocar of handwashing paste fluid gel hand creams and gels for hand washing paint.
- Exterior construction impact plastic pump professional internal steel mechanism, easily removable and cleanable, EPDM seals for long life.
- The dispenser delivers the right amount of hand washing, ensuring maximum hygiene for users and minimizing product giveaway.

Code	Desc.
4110019750	6235

## Liquid hand-wash soap



- Liquid detergent with high washing power, suitable for any kind of cleaning, light cleansing and frequent washings.
- Suitable for the use in offices, communities, restaurants, etc.
- It respects the skin balance and prevents infections.
- **TECHNICAL DATA:**
- Colour: transparent yellow.
- Perfume: characteristic.
- PH: 7+/-0,5.
- Chemical-physical appearance: transparent liquid.

Code	Desc.	Content It
4110015470	3045	5

## Wall distributor lt. 1 for liquid soaps



Code	Desc.
4460005400	3986

## Oil barrier cream



- D.P.I. protective cream (ALL. IV D.L. VO. 626/94).
- It protects the hand skin against contact damage caused from potentially aggressive substances, oil-melted and oil-carried.
- It avoids chapping and the forming of rhagades. It doesn't prevent skin perspiration.
- **USE**
- Smear with the cream on the clean and dry skin before starting the work. Pay much attention on the application among the fingers and under the nails.
- Repeat the application also during the work shift if aggressions are of considerable entity.
- Remove it easily with a cloth or washing.

Code	Desc.	Cont. ml
4110008300	2668	100

## MAPS 2 Serviettes



- Cleansing serviettes of nonwoven fabric (cellulose -polypropylene), abrasive on one side and soft on the other.
- Soaked with special tangerine cleansing solution.
- Use them without water nor soap.
- Efficacious to eliminate oils, tars, glues, fresh painting, printing inks, pen and pen marker inks, photocopier toner, grass traces.
- They remove gasoline and diesel oil smell from the hands.

Code	Desc.	N. wipes
4110015092	2847	70

## Magic hands - Solid hand-wash pulp



- Doughy abrasive product without sand, strong and efficacious. It is a detergent with strong cleaning power, suitable for many kinds of dirt. Pulp colour: clean brown.
- Product made up of anionic and non ionic surfactans, derived only from biodegradable greases and oils.
- Ideal to remove from hands the persistent and intense industrial dirt, like the one produced in the iron and steel, mechanical, chemical, electronic, thermotechnic, building and agricultural industry.
- **HOW TO USE IT**
- Put the magic hands pulp on the wet hands rub till the complete removal of the whole dirt, then rinse and dry.

Code	Desc.	Cont. Lt	Color
4110001060	1904	1	BEIGE
4110008400	2669	5	BEIGE

## Overalls detergent



- Liquid detergent specific to wash overalls both by hand and by washing-machine.
- Suitable to eliminate the most persistent car shop dirt like: oils, greases, dirt, etc.
- Biodegradable product over 90%.
- **USE:**
- Washing-machine: advised temperature 90°. put 250 gr of product every 6/7 overalls.
- Hand wash: pour the detergent out directly on the stains, rub possibly with a rigid brush so as to emulsify the dirt, then rinse in tepid water.

Code	Desc.	Content lt	Color
4110015500	3060	5	PINK

## Multistoff liquid unscrewing fluid



- Very high penetrant power fluid allowing to deblock in a short time any kind of coupling of screws, nuts, studs and any other part threaded by the oxide scaling.
- It melts oxide layers while preventing them from developing again, it lubricates, deblocks, eliminates creaking and frictions, it eliminates humidity.
- Applicable with our pressure supply valves.

Code	Desc.	Content It	Color
4110000870	1805	5	TRANSPARENT

## Multistoff deblocking multipurpose spray



- **CHARACTERISTICS**
- It quickly deblocks and lubricates mechanical parts, assembled or subject to movement, coupling of screws, nuts, studs or any threaded part.
- It also penetrates efficaciously in very close couplings eliminating rust and preventing it from developing again, it lubricates, eliminates humidity and any kind of creaking and frictions.
- **HOW TO USE IT:**
- Spray the product from a distance of about 20cm. on screws, bolts, nuts, gears, locks and on any mechanical coupling blocked by scaling. Let it work for some minutes to let the product penetrate deeply.

Code	Desc.	Content ml	Color
4110000900	1808	400	TRANSPARENT

## Rust 4 remover "Premium"



LINEA MANUTENZIONE **PREMIUM**

- High fluid unlocking power, degrippante and penetrating, indicated for the fast release of screws, bolts, assembled parts, threads, prisoners, etc..
- The base of the product is a very penetrating liquid, which is able to enter deeply into rusty and blocked parts, releasing the tension that does not allow dismantling of the parts, dissolving the oxidation and taking with them the content within the spray MOS2, a natural lubricate that allows the parties to loose more easily after the first movement.
- The new formulation with molybdenum disulphide even more micronized and unlocking the power of the liquid boosted it even easier the disassembly work, covers the parts treated with a lubricant and protective coating, it helps to expel moisture and dissolves all deposits of organic origin.
- The 4 Rust remover Premium is excellent especially for use in the boating and marine areas, where the action of the salt is very aggressive.
- **How to use**
- Shake the can well before use, spray the product on the parts to be treated, taking care to wet them thoroughly.
- Wait a few minutes to allow the product to penetrate into the inlay, and then proceed to the release. If necessary, repeat the operation several times.

Code	Desc.	Content ml	Color
4110020180	6340	400	Grey

## Rust 4 remover



- High deblocking power fluid . usable for the immediate deblocking of screws, bolts, assembled parts, etc.
- Strong migratry power of the product that allows a quick penetration between blocked parts, it forms a dividing bearing between the two parts and allows the disassembly in a very short time.
- It lubricates and avoids any kind of contact ,eliminating any kind of creaking.
- It eliminates stains of tar, lubricants, resins,etc.
- **HOW TO USE IT**
- Spray the product from a distance of about 20 cm, on screws, bolts, nuts, gears, locks and on any mechanical coupling blocked by scaling.
- Let it act for some minutes to allow the product to penetrate and work also in the deep. If necessary repeat the operation.

Code	Desc.	Content ml	Color
4110015340	2950	400	DARK GRAY



## Multistoff Freeze -40



- Un-blocker un-gripper with a cooling effect. It allows for immediately unblocking any joints or threading blocked and encrusted by rust, or gripped in by heat.
  - Spraying of the product allows for cooling the treated part up to a temperature of -40°C, causing a thermal reduction that immediately unblocks the gripped parts, and at the same time allows for the un-blocker to penetrate inside blocked joints.
  - Ideal for quickly unblocking screws, nuts, bolts exhaust manifold clamps, boiler flanges, drainpipes.
  - A very effective product for use on parts corroded by salt.
- HOW TO USE**
- Spray onto the parts to be unblocked from a distance of 5/10 centimetres for a few seconds, so as to cool the part treated. Unblock the part with appropriate tools. If the operation fails, repeat the procedure.

Code	Desc.	Content ml	Color
4110016150	3885	400	TRANSPARENT

## White mineral oil of enological degree



- Very pure white mineral oil, of enological degree, colourless and odourless. It doesn't decay even in presence of water.
- Usable successfully on rollers, guides, grids, gears, it protects all chromium-plated parts from the aggression of saltness and atmospheric agents. Very good regenerator of plastic and rubber parts.
- It softens and protects gaskets, it protects the battery poles, it prevents seizing, it resists till temperatures higher than +130°C.
- Ideal for the mechanical, food, medical, shipping, air-conditioners, aerotechnics, etc.
- Absolutely not toxic.
- Applicable with our pressure supply valves.

Code	Desc.	Content lt
4110000008	8	5

## Very pure white mineral oil spray



### • CHARACTERISTICS

- Pure white mineral oil with high lubricating power.
- Usable successfully on rollers, guides, grids, gears, it protects all chromium-plated parts from the aggression of saltiness and atmospheric agents. Very good regenerant of plastic and rubber parts.
- It softens and protects gaskets, it protects the battery poles, it prevents seizings, it resists till temperatures higher than +130°C.
- Ideal for the mechanical, food, medical, shipping, air-conditioners, aerotechnics, etc. industry.

### • HOW TO USE IT:

- Spray the product from a distance of about 20 cm. on the part to be treated.

Code	Desc.	Content ml
4110001052	1890	400

## Pure vaseline grease



- Pure vaseline grease, of enological degree, odourless and colourless.
- Suitable on battery charging clips as antioxidant, on electric aerials as protection and to help their sliding, on the wires of the mileometers, on any kind of wire to help the sliding. On the spindles of the battery coil ignitions and on the gears of the windscreen wipers, on all those parts where you want to prevent the forming of rust, oxides and attacks from the atmospheric agents.
- Widely used in the mechanical, food, sanitary, shipping, aerotechnics industry and of driving.
- The vaseline grease becomes liquid at 50° C.
- It not toxic and it it does not dirty.

Code	Desc.	Cont. KG	Color
4110000011	11	1	TRANSPARENT
4110008900	2674	0,2	TRANSPARENT

## X 2002 - Silicone spray



- **CHARACTERISTICS**
- Protective insulating lubricant based on pure silicone.
- It offers detaching, antiadhesive, water repellent and antistatic properties.
- It can be used for the lubrication of industrial machineries, as polish and protective agent for all plastic, rubber, aluminium, etc. parts; it increases the length of gaskets preventing their cracking and increasing their seal.
- Very good to regive water resistance on lorry tarpaulins, car hoods and camping tents.
- It protects from humidity all electric contacts.
- **HOW TO USE IT:**
- Spray the product from a distance of about 30 cm. on the interested areas. It can be spread with a cloth to repel the dust from surfaces.
- **ATTENTION:** do not put the product on glasses or car glasses.

Code	Desc.	Content ml
4110001100	X2002	400

## Spray silicone grease



### CHARACTERISTICS

- Spray grease with no metallic soaps.
- It protects from corrosion and oxidation of any kind of electric terminal.
- Suitable for the lubrication of O-Ring, gaskets of any kind, car aerals, it protects battery charging clips.
- It can be used as detaching product in the pressing of plastic materials. It has a water repellent action and it disperses heat. Absolutely not toxic.
- Resistance to temperature from -50°C to +280°C.

### HOW TO USE IT

- Spray the product from a distance of about 20 cm. on the parts to treat.

Code	Desc.	Content ml	Color
4110009900	2684	400	WHITE

## Silicone grease



- Silicone grease for high and low temperatures, in the range of from -30 ° C to + 200 ° C.
- Excellent gliding on average per pair loaded. Protection against corrosion, oxidation, moisture on cables, battery terminals, connectors and electrical and mechanical parts in general.
- Suitable for lubrication of O-rings, gaskets, car antennas, plastic parts and rubber.
- High dielectric strength of 12KV / mm, can also be used as an insulating layer.

Code	Desc.	Content gr.	Color
4110014825	2777	900	WHITE

## Liquid Silicone



- Protective insulator based on pure silicone. It offers detaching, antiadhesive, water repellent and antistatic properties.
- Very good as regenerant and renovating product for plastics, ABS, rubber sky and artificial leather.
- It can be used as detaching an antiadhesive product, as waterproofing agent for car hoods, regenerant for car and motorcycle tyres, tarpaulins and spoilers, it prolongs the life of gaskets and increases their seal.
- Applicable with our pressure supply valves.
- **ATTENTION:** do not put the product on glasses or car glasses.

Code	Desc.	Content lt	Color
4110009250	2677/1	5	TRANSPARENT

## Universal Lithium grease



- High quality multipurpose complex lithium soaps grease. Product suitable for the lubrication of bearings, rollers, joints, supports, guides, hinges, etc.
- It stands up to temperatures between -30°C and +120°C.
- Very good resistance to intense use, bad weather and the washing-away action of water. Yellow translucent.
- Available in cartridges of 600 and 400 g, apply through our grease hand or tires.

Code	Desc.	Cont. KG	Color	Ingrassatore
4110003700	2622 - Ø56	0,6	YELLOW	443 00 33800-384-Pneumatic 443 00 44430-494-Manual
4110003710	2662/1 - Ø52	0,6	YELLOW	-
4110017410	4345 Ø52	0,4	YELLOW	443 00 53930-1083-Manual
4110014835	2779	0,9	YELLOW	-
4110014840	2780	24	YELLOW	-

## Universal Lithium soaps spray



- **FEATURES:** Spray grease to lithium soap white.
- Product suitable for the lubrication and protection of all the moving parts and subjected to water washout (auto, marine engines and all the parts exposed to the elements).
- Perfect adhesion to surfaces without leaving burrs, indicated impegno for operating temperatures up to + 120 ° C.
- It can be used in the automotive light and heavy construction and maintenance of windows, gates, machinery and any moving parts.
- **HOW TO USE:** Shake the can well before use, then spray the product from a distance of about 20 cm. on the part to be treated.
- **IMPORTANT:** The surface must be perfectly clean, dry and degreased. Not suitable for food use.

Code	Desc.	Content ml	Color
4110000710	1037	400	WHITE



## General graphite treated grease



- Special lithium grease with addition of graphite and molybdenum bisulphide, suitable for lubrications particularly hard on land moving machines, building machines, industrial and heavy transport vehicles.
- Very good for the treatment of big bearings, gear changes, pin joints, pins, ferrules, sliding planes, guides, fifth wheels, etc.
- Very good tack powers, waterproofness, anticorrosion and anti-wear.
- Resistance to temperature from -15°C to +120°C.
- Available in cartridges of 600 and 400 g, apply through our grease hand or tires.

Code	Desc.	Cont. g	Color	Ingrassatore
4110014625	2737 - Ø56	600	BLACK	443 00 33800-384-Pneumatic 443 00 44430-494-Manual
4110014627	2737/1 - Ø52	600	BLACK	-
4110017420	4350 - Ø52	400	BLACK	443 00 53930-1083-Manual

## CM54 blue stringy grease in cartridges



- Special synthetic-based grease for lubricating parts subjected to elevated stress in the agricultural, quarrying, mining, earth moving and vehicle transport fields.
- Particularly indicated where a strong adhesion of the lubricant against movements is required and where a high resistance to water, even brackish water is required.
- Does not contain solid particles such as graphite, molybdenum disulphide, P.T.F.E., etc. suitable for lubricating all types of ball or roller bearings, cables, chains and dragging movements. Elevated stringy properties.
- Resistance to variations in temperature: from -20°C to +130°C.
- Available in cartridges of 600 grams and 400 grams. Can be applied using our pneumatic or hand grease guns.

Code	Desc.	Cont. KG	Color	Ingrassatore
4110016590	4110 - Ø56	0,6 (650 ml)	BLUE	443 00 33800-384-Pneumatic 443 00 44430-494-Manual
4110016593	4110/1 - Ø52	0,6 (600 ml)	BLUE	-
4110017430	4355 - Ø52	0,4	BLUE	443 00 53930-1083-Manual
4110016595	4111	24	BLUE	-

## P.T.F.E. oily lubricant



### CHARACTERISTICS

- Product thought and made for the use where it is not proper to use greases of conventional kind.
- Suitable for the lubrication of creeping details like seat guides, sunroofs, hinges, etc.
- Suitable for lubrications in precision mechanics, military equipments, optical equipments, nautical equipments, etc.
- Perfectly waterproof, even salt. It doesn't interfere with processes like printing, painting, metallizing, gluing.

### HOW TO USE IT

- Spray the product from a distance of about 20 cm. on the part to treat. A very thin film will form, that allows its use also in those cases where tolerances are minima.
- Thanks to the special supply valve, you can also reach the most difficult points.

Code	Desc.	Content ml	Color
4110015280	2884	400	WHITE

## P.T.F.E. trasparente lake



### CHARACTERISTICS

- It is a P.T.F.E. trasparente lake ideal for metals, rubber, plastic, leather, wood, glass and paper.
- Ideal to solve any problem of friction, slip or friction.
- It doesn't stain nor grease.
- It resists the atmospheric agents, gasolines, oils and acids maintaining its action also for a long time.
- Drying time 5-10 minutes at 20° C.
- Hardening time 30 minutes at 20° C.
- Resistance to temperature: -180° +240°.

Code	Desc.	Content ml
4110002300	2609	400

## MEC-VFC730 stringy grease



- **FEATURES:** Lubricating grease synthetic very high tackiness, transparent color.
- Suitable for the lubrication of chains, ropes, transmissions, submerged parts, etc.
- High property streamers.
- The solvent enables it to penetrate deeply into all the gaps, then, once evaporated, the product clings tenaciously to the treated parts.
- Excellent resistance to atmospheric agents, water repellent, prevents corrosion by the salt and acid solutions is both bases.
- **HOW TO USE:** Shake the can well before use.
- Spray the product from a distance of about 20 cm. on the part to be treated.

Code	Desc.	Content ml
4110013900	2725	400

## Cut Oil Tap Spray cutting oil



- Specific lubricating and cooling fluid, suitable to tap, thread, mill, turn and drill.
- Perfectly suitable for working on any kind of metal and alloys, like special steels, inox, nickel, titanium, bronze, aluminium, brass, etc.
- Very good cooling and sliding powers, that allow it to eliminate the scraps from working, reduce the risk of breaking of the tools, avoiding the forming and the fusion of surfacing elements.
- Very good protection from rust and corrosive agents.

Code	Desc.	Content ml	Color
4110001900	2605	400	TRANSPARENT



## Cutting oil spray for production machinery



- Huile minérale raffinée dans laquelle on a ajouté un additif spécifique en vue de l'utilisation sur les filières électriques et mécaniques, indiquée tout particulièrement pour le filetage de tuyaux en acier dans le secteur thermo hydraulique.
- Elle lubrifie et refroidit les outils en augmentant leur durée et leur bon fonctionnement, elle empêche que les copeaux se soudent.
- À utiliser pur directement sur les parties à traiter. On peut éliminer le produit facilement avec de l'eau.
- Résistance thermique de -30 à +200°C.

Code	Desc.	Content ml
4110015590	3105	600

## Integral cutting oil for light metals



- Fluid integral nature of paraffin, white, odorless, pure to be used for all machining operations of shearing, pressing, milling, etc. of mechanical pieces in aluminum and its alloys.
- Excellent corrosion protection, excellent metal removal, lubrication and cooling.
- It increases tool life and not form foams.
- Excellent atomization.
- For general use on all machines both manual and automatic.

Code	Desc.	Content lt
4110015225	2873	5

## Emulsifiable cutting oil



- Emulsifiable fluid, cooling and lubricating for any kind of working, usable with any kind of metals, both ferrous and on yellow alloys and aluminium.
- Of universal use for operations of turning, milling, broaching, cut, etc.
- The emulsion produced has a good seal to bacterial decomposition and a very good stability.

Code	Desc.	Content It
4110014860	2784	5
4110019315	5950	20

## Air Oil



- Special paraffin oil for air-compressed systems, to protect them from the corrosive action of condensate.
- Very good resistance to oxidation.
- High anti-rust power.
- High demulsification power, easy nebulization.
- Viscosity at 50°e: 13,5 - 15,55 Cst.
- Sliding: -27°C.
- Indispensable air-compressed lines to protect electric valves and pneumatic tools.

Code	Desc.	Content It
4110014865	2785	1

## Hydraulic oil ISO68



- High-quality special oil for hydrodynamic transmission systems, in hydraulic devices and in hydrostatic systems.
- High viscosity value even varying the temperature according to the specific ISO68.
- Very good antioxidant and antirust properties. High anti-foam power.
- Very good antiwear (it passes the tests on vickers pumps 250 hours - 1200 rev/min. - 250 atm).
- Used in heavy drive and land moving, precision machineries and equipments.

Code	Desc.	Content It
4110014880	2788	5

## Ralle grease

- A specific grease for lubricating fifth wheel couplings of articulated vehicles.
- Dark brown colour, high adhesion ability, excellent resistance to water.
- Operating temperature: up to +100°C.



Code	Desc.	Content Kg
4110014855	2783	5

## Spray anti-seizing copper grease

### CHARACTERISTICS

- Lubricating and anti-seizing pulp based on copper, resistant to low and hightemperatures from -30°C to +1100°C, and to high pressures.
- Unaffected by corrosive agents, like salt water, petroleum, oils, acids and alkali, with extraordinary anti-seizing, anticorrosive, anti-ruste, antiadhesive, and lubricating qualities for the most various use conditions.
- Good tack on all supports, it prevents wear in contacts metalmetal, seizing, friction, overheating and corrosion.
- Suitable for the use on the nuts of the exhaust manifolds, for the nuts of tyres, pins of the leaf springs, joints, internal surface of the wheel rims, on wires and chains, pins and bolts in general.

### HOW TO USE IT

- Spray the product from a distance of about 20 cm. on the part to treat. Thanks to the special supply valve you can also reach the most difficult points. Anti-seizing for very high temperatures.



Code	Desc.	Content ml
4110015490	3055	200

## Spray grease to aluminum



- Special grease based on aluminum **with excellent lubricating properties and anti-seize, with a strong resistance to very high temperatures, up to + 1200 ° C**. Form coverage on objects handled by the typical gray brilliant effectively lubricates and protects against corrosion in atmospheric and chemical agents.
- Indicated in the workshops and to work in the plumbing and heating industry. Typical indications: nuts and bolts, wheels, dice exhaust manifolds of cars, the threads of candles motor, the back of the brake pads, boilers and pipes of hot water and steam, drain pipes, to any of the threaded part or wherever there is a movement in sliding
- It can be applied to every element subjected to high temperature fluctuations, or exposed to corrosive moisture, salt, acids and bases. Facilitates easy removal of the treated even after a long time, it does not drip and does not soil the treated surfaces.
- **HOW TO USE**
- Shake the can well before use. Spray from a distance of about 15 cm on the part to protect and lubricate. To installation.

Code	Description	Cont. ml
4110019960	6318	400

## Copper pulp



- Anti-seizing pulp made up of ultra thin particles of lamellar copper, anticorrosive, anti-rust, antiadhesive and lubricating.
- Suitable for the use on exhaust manifold pins, joints, screws, nuts, studs, hinges, nipples, etc.
- High resistance to very high temperatures, high tack and moldability allow its use for all those cases in which heat or highly corrosive substances can create irreversible blockings.
- Resistance to temperatures from -30°C to +1100°C.

Code	Desc.	Cont. g	Color
4110014805	2773	900	GREEN

## Spray grease for food industries



- Spray grease of high quality 'used for the lubrication of machinery used in the food industry. Approved and certified nsf
- In class H1.
- Allows the lubrication of any moving part such as: metal to metal, metal to plastic, springs, gears and worms, bearings, hinges, conveyor belts, tires stabilization, etc.
- Certification nsf h1 endorse the accidental contact with food, not 'harmful it' toxic for the human body, can maintain the efficiency of any machinery and gear.
- Withstands temperatures from -30 to + 160 ° c, and 'water-repellent, resistant to bases and weak acids, it prevents wear and reduces friction thanks to the ptfе
- Content, high viscosity 'and adhesiveness'.
- NSF-H1 No. 145844.

Code	Desc.	Content ml	Color
4110019340	5965	500	Beige

## White grease



- It is a special lubricating grease, white colour, that causes no kind of harmful pollution with food machines.
- Used mostly as lubricating grease on members and machines in the pharmaceuticals and food industry.
- Resistent to low and high temperatures: -30°C +120°C.
- Comparable to the product Molykote Longterm W2.

Code	Desc.	Cont. g	Color
4110014820	2776	900	WHITE



## Calcium grease



- E' un grasso al calcio particolarmente indicato su applicazioni soggette al contatto con acqua e acqua salina.
- Utilizzato in nautica, industrie cartiere, tessili, impianti di depurazione acque, centrali idroelettriche.
- Preserva dall'umidità e dall'ossidazione.
- Di colore ambrato, aspetto pomatoso-fibroso.
- Alta adesività.
- Resiste a temperature comprese fra -15°C a +90°C.

Code	Desc.	Cont. g	Color
4110014830	2778	900	GREEN

## MLT grease



- It is a universal lithium soaps grease with the addition of molybdenum bisulphide.
- Great mechanical stability, very good resistance to oxidation, humidity and corrosion.
- It reduces wear, noisiness and friction.
- Suitable for the lubrication of bearings, carter gears and constantvelocity joints.
- Resistant to low and high temperatures: -20°C +140°C.
- Black Colour

Code	Desc.	Cont. g
4110014815	2775	900

## MR Grease



- It is a multipurpose grease, specific for wheel-hub bearings of commercial and heavy vehicles.
- Very good mechanical stability. High anticorrosive power. considerable chemical stability.
- High degree of oiliness and tack. Good resistance to the action of water.
- Ointment-stringy aspect. Colour dark brown.
- Resistance to temperatures: -20°C +120°C.

Code	Desc.	Cont. g
4110014845	2781	900

## Spray lubricant for locks



- **CHARACTERISTICS:**
- Mineral oil-based lubricant, specifically designed to unlock, cleanse, restore all small mechanical movements such as locks, spindles, tools, etc.
- Eliminates and prevents the formation of rust, protects against corrosion and rusting, it removes humidity.
- **HOW TO USE:**
- Spray the product from a distance of about 20 cm., Or directly inside the mechanism through the appropriate cannula, leave for a few minutes, reactivate the mechanism itself.
- If necessary, repeat the operation.

Code	Desc.	Cont. ml	Color
4110015265	2881	200	YELLOW

## Cable-feeding liquid



- **CHARACTERISTICS:**
- Creamy fluid based on surfactants, suitable for facilitating the sliding of the electrical cables in the presence of narrow passages and curves very accentuated.
- The particular formulation does not damage the insulation of the cables, but prevents deterioration over time even easier processing.
- Absolutely not harmful for the skin.
- **HOW TO USE:**
- Apply the product directly on the cable or inside the hose by means of the hands, a brush, or other dispenser.

Code	Desc.	Content ml	Color
4110015240	2876	1000	WHITE

## Lubrificante scorricavo spray siliconico



- Speciale lubrificante scorricavo a base siliconica, indicato per eliminare l'attrito e migliorare lo scorrimento di cavi elettrici in tubature, canaline e guaine.
- Particolarmente adatto per il passaggio di cavi in condutture con molte curve, strozzature, dislivelli, ecc.
- Ha azione protettiva nei confronti dei cavi, ne evita l'invecchiamento, l'ingiallimento e facilita l'eventuale sfilamento in seguito.
- La base siliconica evita falsi contatti e protegge i cavi dall'umidità.
- **MODO D'USO:** Spruzzare abbondantemente sui cavi ed all'interno delle tubazioni prima e durante il passaggio.

Code	Desc.	Content ml	Color
4110002100	2607	400	TRASPARENTE

## Scivolante in gel per tubazioni e cavi elettrici



- Scivolante siliconico di forma gelatinosa e di colore bianco.
- Indicato per impieghi quali: accoppiamenti di giunti ad anello elastico per tubi tipo UNI 303 e UNI 313, e lo scorrimento di cavi elettrici, telefonici e coassiali in tubazioni di ferro plastica e cemento.
- Permanentemente plastico, mantiene nel tempo inalterate le proprie doti lubrificanti.
- Grazie alla particolare forma del contenitore, lo scivolante può essere facilmente immagazzinato e trasportato in cassette portautensili. Tappo con chiusura a scatto, impossibile da perdere.
- Non sporca, non è tossico.
- Ininfiammabile.

Code	Desc.	Content gr.
4110017960	4600	250



## MS glass adhesive sealant for glasses



- The MS Glass is a fast-setting adhesive designed for bonding and quick replacement of the windscreen and fixed the auto industry. Perfectly compatible with the products used as original equipment by automotive manufacturers.
- Intended Use: bodywork, replacement centers faster windshield bonding of crystals in the body of transformation vehicles.
- The formulation based on polymer ms and drying speed allow the return of the car after only one hour, even if equipped with single or double airbag. He grips the old mastic perfectly without the use of primer, and allows to maintain the rigidity of the vehicle after the replacement of the glass.
- Unlike a polyurethane sealants, the MS Glass not dirty, easy to clean after application, suffers much less of changes in temperature and no emissions harmful to humans.
- Does not drip even when applied vertically, perfectly compatible with the antennas included in electronic crystals, also applies on painted surfaces or bare metal using our MS Primer cod. 411 00 19110.

### HOW TO USE:

- Cut away the old caulk and remove the broken glass. Do not remove all of the old putty from the body, but leave one minimum thickness of 1 mm. Do not allow the surface of the old sealant is dirty. In this case clean it thoroughly before processing.
- Thoroughly clean the surface of the crystal to be bonded and make sure it is perfectly dry.
- Use sealant on the edge of the glass and apply it on the car within 5 minutes.
- In the case of painted or bare metal surfaces, apply a thin layer of primer MS, wait until the drying from 5 to 60 minutes and bonding.

Code	Desc.	Content ml	Color
4110014000	2726	290	Black

Technical Features	
Resistenza a rottura per trazione	4 MPa
Resistività elettrica	>10 <sup>10</sup> ohm x cm
Lengthening at breaking	>250%
Tempo di formazione della pelle	5 min.
Resistenza all'allungamento	2,5 MPa
Durezza Shore A	65
Modulo elastico al 10%	>2 MPa
Solids content	>98%
Aspect	Thixotropic paste
Density	1,5 g/cm <sup>3</sup>
Temperatura di accensione	>60°C

## MS Primer - Special primer for MS Polymer products.



- It improves the adhesion of our sealant MS Glass of crystals with silk screen and painted body of the vehicle.
- Dries quickly, in about 10 minutes at 20°C, easy to use as "wash primer", effective use.
- It is recommended to keep the container tightly closed and do not use the primer directly from the original packaging to avoid contamination of the contents.

Code	Desc.	Content ml	Color
4110019110	5745	30	Transparent

## Brushes for Primer



- Brushes for the application of primer and cleaning of screen printed parts of the glasses.

Code	Desc.
4110014200	2728

## Meccanoglass polyurethane adhesive sealant



- Meccanoglass is a quick-setting polyurethane adhesive designed for bonding and quick replacement of the windscreen and fixed the auto industry. Perfectly identical and compatible with those that are used as original equipment by automotive manufacturers.
- Intended Use: bodywork, replacement centers faster windshield bonding of crystals in the body of transformation vehicles.
- The polyurethane formulation and the drying speed allow the return of the car after only one hour, even if equipped with single or double airbag. He grips the old mastic perfectly without the use of primer, and allows to maintain the rigidity of the vehicle after the replacement of the glass.
- Does not drip even when applied vertically, perfectly compatible with the antennas included in electronic crystals, also applies on painted surfaces or bare metal using our glass primer cod. 411 00 12800-12900.

### HOW TO USE:

- Cut away the old caulk and remove the broken glass. Do not remove all of the old putty from the body, but leave one minimum thickness of 1 mm. Do not allow the surface of the old sealant is dirty. In this case clean it thoroughly before processing.
- Thoroughly clean the surface of the crystal to be bonded and make sure it is perfectly dry.
- Extrude the sealant on the edge of the glass and apply it on the car within 5 minutes.
- In the case of painted or bare metal surfaces, apply a thin layer of primer glass, wait until the drying from 5 to 60 minutes and bonding.

Code	Desc.	Content	Color
4110012700	2713	Aluminum cartridge 310 ml	Black
4110017810	4527	Bag 400 ml	Black

Tecnical Features	
Velocità di essiccazione a 23°C-50% H.R.	Skin formation: 5 minutes After 5 hours: 1.6 mm
Tempo di posa dopo applicazione	5 minutes
Resistenza all'allungamento	5 MPa
Resistenza a rottura per trazione	10 MPa
Lengthening at breaking	400%
Durezza Shore A	58
Temperatura di accensione	>70°C
Solids content	Approx. 98%
Aspect	Thixotropic paste
Density	1,2 g/ml

## Cristal kit

It is a kit studied purposely for the structural gluing of car glasses and fixed windows made up of the following items:

- N° 1 cleaning buffer
- N° 1 15 ml primer glass bottle our code 411 00 12800 - 2714
- N° 1 solvent bottle
- N° 1 310 ml adhesive polyurethane cartridge our code. 411 00 12700 - 2713
- N° 1 nozzle to extrude the adhesive
- N° 2 spacer inserts for the correct laying of glasses
- N° 1 piano wire roll to cut the old adhesive



Code	Desc.
4110012600	2712

## Primer glass



- To put on the edge of the windscreen to clean the surface.
- Its action prepares with efficacy and stability the application of the meccanoglass single-component polyurethane adhesive sealant code 411 00 12700 - 2713.
- Color black.

Code	Desc.	Content ml
4110012800	2714	30
4110012900	2715	250

## Screen Car polyurethane adhesive for crystals large stationary



- Screen Car is a polyurethane adhesive designed for bonding and replacement of windscreen and fixed in each transport sector. Perfectly identical and compatible with those that are used as original equipment by manufacturers.
- Intended Use: bodywork, body heavy vehicles, windshield replacement in public transport, bonding of crystals in the body of transformation vehicles, construction of railway carriages, cabins of cable cars, etc.
- The polyurethane formulation and the right drying speed allow the manufacture of large crystals without problems of formation of the skin and consequent lack of bonding. He grips the old mastic perfectly without the use of primer, and allows to maintain the rigidity of the vehicle after the replacement of the glass.
- Does not drip even when applied vertically, perfectly compatible with the antennas included in electronic crystals, also applies on painted surfaces or bare metal using our glass primer cod. 411 00 12800-12900.

### HOW TO USE:

- Cut away the old caulk and remove the broken glass. Do not remove all of the old putty from the body, but leave one minimum thickness of 1 mm. Do not allow the surface of the old sealant is dirty. In this case clean it thoroughly before processing.
- Thoroughly clean the surface of the crystal to be bonded and make sure it is perfectly dry.
- Extrude the sealant on the edge of the crystal and apply it on the medium within 10 minutes.
- In the case of painted or bare metal surfaces, apply a thin layer of primer glass, wait until the drying from 5 to 60 minutes and bonding.

Code	Desc.	Content	Color
4110017790	4525	310 ml	Black

Technical Features	
Lengthening at breaking	650%
Durezza Shore A	62
Velocità di essiccazione a 23°C-50% H.R.	Skin formation: 10 minutes After 24 hours: 4 mm
Temperatura di accensione	>70°C
Solids content	Approx. 97%
Tempo di posa dopo applicazione	10 minutes
Resistenza a rottura per trazione	>9 MPa
Aspect	Thixotropic paste
Density	1,22 g/ml

## Black IB butyl sealant 21



- It is a sealant based on butyl rubber.
- Particularly used to seal rubber gaskets with fixed glasses, or of tinned materials and sheet metals.
- Used in the building industry to seal aluminium and glass door and window frames.
- Optimum adhesion, it doesn't drip.
- Permanently flexible.
- Very good resistance to air and water passage.
- Excellent resistance to thermal expansion.
- Resistance to temperature: -20°C +130°C.
- Complete drying: within 24h.
- It doesn't eat into chrome plating, paints and rubber.

Code	Desc.	Content ml	Color
4110014680	2748	300	Black



## Glass repair kit



- The kit allows Meccanocar to repair 90% of fractures of the crystals damaged by strokes or stone chippings.
- Quick and easy to use.
- Suitable for windshield repair cars and trucks.
- The repair allows the glass to preserve all its characteristics and properties.
- It is not necessary to remove the windshield.
- Supplied in a practical case.
- The package of syringes resin includes: N°6 syringes and needles N°3 spare.

### PRINCIPALI TIPOLOGIE DI FRATTURA DEL VETRO



Code	Desc.
4110016610	4120

### PARTI DI RICAMBIO



### MODALITA' DI IMPIEGO



- 1) Individuare la frattura nel vetro
- 2) Pulire la superficie da trattare con la punta per pulizia in dotazione
- 3) Dopo aver applicato il beccuccio inserire la resina



- 4) Tramite la pompa creare inizialmente il vuoto d'aria in modo da far defluire completamente la resina all'interno della frattura. Esercitare con la stessa una elevata pressione facendo sì che la resina vada a riempire ogni spazio disponibile
- 5) Completata l'operazione di riempimento, applicare una goccia di resina nel foro di entrata della frattura, coprirla con foglio MYLAR
- 6) Essiccare la resina con la lampada UVA, togliere la pellicola, asportare la resina residua con l'apposito raschietto per vetro e applicare una goccia di Polish lucidando la superficie trattata

Spare Parts			
Article	Code	Description	Photo
Liquid resin 8 ml.	4110016620	4125	1
Resin filler 8 ml.	4110016630	4130	2
Resin polish 15 ml.	4110016640	4135	3
Mylar sheets 20 pcs.	4110016650	4140	4
Bi-adhesive rings 25 pcs.	4110016660	4145	5
Scraper	4430045285	559	6
Scraper blade 10 pcs.	4430045295	561	7
Nozzles for resin 25 pcs.	4110016670	4150	8
Plastic injector	4110016680	4155	9
Flexible pressure tube	4110016690	4160	10
Neon for U.V. lamp	4110017000	4165	11
Complete U.V. lamp	4110017010	4170	12
Carbide pen	4110016700	4161	13
Connection spout	4110016710	4162	14
Dimmer	4110019010	5645	15
Syringes for resin (not included in the kit)	4770006370	728	16

## Kit bonding glass metal



- Meccanocar kit to glue the metal plates of the mirrors on the glass.
- Article suitable for auto body shops, v.i. and repair centers crystals.
- The kit consists of a practical sealant bellows and a bottle of primer with a brush and spray dispenser for application.
- The kit allows you to attach the plates of the mirrors in a simple, effective and definitive.
- Before treatment is necessary to clean and degrease the metal part is that the glass on which the adhesive is applied. Subsequently pass the primer on both sides by brush or spray nozzle supplied. Wait a few seconds and then assayed only two drops of adhesive on the board.
- Place the plate glass and to adhere well. After a minute the plate is perfectly bonded and after 5 minutes you can replace the mirror.
- The gluing system is very practical and the kit allows many applications. The adhesive is a single component anaerobic with high mechanical strength and temperature. Not dirty, not runny.
- The kit consists of a glue in the bellows 30 g and a bottle of primer 30 ml equipped with a brush and spray dispenser for application.
- The product is usable for all types of bonding between glass and metal and painted metals between them.

Code	Desc.
4110019170	5800

## Electro-conductive silver paint for repairs of electronic circuits and heated rear windows

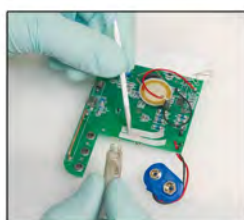

- Special paint silver-based, electrically conductive. It allows easy repair of printed circuit boards, electrical, and the restoration of the slopes of the broken car heated rear windows.
- Suitable for repair work in the auto industry and electric. It is easily applied by defining the edges of the runway to be reconstructed with tape, and applying the paint with a brush.
- It adheres well to glass, epoxy glass, bakelite, plastics, metals, ceramics, etc..

Code	Desc.	Content gr.
4110019405	6040	3

## Bicomponent gel for rain sensors



- Gel-component specific to reposition rain sensors on the windshield of the vehicle after the replacement.
- Suitable for all car body shops and vehicles, repair centers and window replacement, mechanical, elettrauto.
- The product is contained in a two-component syringe 4 ml, by the use semplicissimo and immediate.
- The two components are mixed with the nozzle as supplied and recreate the adhesive pad on the sensor to hang up.
- Crosslinking of the gel is influenced by ambient temperature. We should use the briefcase heating to speed the reaction of the two components, our item code 477 00 05835-707. it can halve the time and speed up the work.

Code	Description	Content ml
4110019360	5975	4

## Mixers Replacement cartridges 4-6 ml



- Mixers Replacement cartridges 4-6 ml

Code	Description
4110019370	5980

## Heating case rain sensor



- Carrying case with a heater to raise the temperature of the gel-component sensors rain and speed drying.
- The use of the briefcase enables the correct use of the gel even at very low temperatures down to -15 ° c, and speeds up the work of application.
- Also it has a bubble for leveling, and facilitates the application of the product avoiding debordamenti.
- Supplied with cigarette lighter connection for cars, operating at 12 volts, an adapter is available separately for use with voltage 220 volts.
- Dimensions: 20 x 16 x 4 cm. weight: 300 g. power consumption: 4 w.

Code	Description
4770005835	707

## Power supply to the heating suitcase

- Power supply to the heating suitcase.



Code	Description
4770005840	707/A



## Aderfix instantaneous adhesive



ΚΟΛΛΗΤΙΚΗ ΟΥΣΙΑ ΕΝΟΣ ΣΥΣΤΑΤΙΚΟΥ ΒΑΣΗ ΚΥΑΝΟΑΚΡΥΛΙΚΟΥ, ΧΩΡΙΣ ΔΙΑΛΥΤΙΚΑ. ΣΚΛΗΡΑΙΝΕΙ ΠΟΛΥ ΓΡΗΓΟΡΑ ΚΑΙ ΣΤΕΓΝΩΝΕΙ ΣΕ ΚΡΥΑ ΚΑΤΑΣΤΑΣΗ. ΠΟΛΥΧΡΗΣΤΙΚΟ ΚΑΙ ΚΑΤΑΛΛΗΛΟ ΓΙΑ ΚΟΛΛΗΣΗ ΣΕ ΣΧΕΔΟΝ ΚΑΘΕ ΥΛΙΚΟ. ΚΑΤΑΛΛΗΛΟ ΓΙΑ ΚΟΛΛΗΣΗ ΤΣΙΜΟΥΧΩΝ ΣΕ ΠΟΡΤΕΣ ΚΑΙ ΠΑΡΑΘΥΡΑ ΚΑΙ ΣΕ ΑΥΤΟΚΙΝΗΤΑ, ΓΙΑ ΕΦΑΡΜΟΓΕΣ ΣΕ ΕΡΔΜ/DUTRAL. ΠΟΛΥΜΕΡΙΖΕΤΑΙ ΓΡΗΓΟΡΑ ΣΤΙΣ ΕΠΙΦΑΝΕΙΕΣ ΠΟΥ ΕΦΑΡΜΟΖΕΤΑΙ. ΝΕΑ ΣΥΣΚΕΑΥΣΙΑ ΜΕ ΚΑΠΑΚΙ ΒΕΛΟΝΑΣ. ΑΠΟΤΡΕΠΕΙ ΤΗΝ ΑΠΟΦΡΑΞΗ ΤΗΣ ΑΚΡΗΣ.

Code	Desc.	Cont. g
4110003900	2624	10

## Aderfix gaskets



ΚΟΛΛΗΤΙΚΗ ΟΥΣΙΑ ΕΝΟΣ ΣΥΣΤΑΤΙΚΟΥ ΒΑΣΗ ΚΥΑΝΟΑΚΡΥΛΙΚΟΥ, ΧΩΡΙΣ ΔΙΑΛΥΤΙΚΑ. ΣΚΛΗΡΑΙΝΕΙ ΠΟΛΥ ΓΡΗΓΟΡΑ ΚΑΙ ΣΤΕΓΝΩΝΕΙ ΣΕ ΚΡΥΑ ΚΑΤΑΣΤΑΣΗ. ΠΟΛΥΧΡΗΣΤΙΚΟ ΚΑΙ ΚΑΤΑΛΛΗΛΟ ΓΙΑ ΚΟΛΛΗΣΗ ΣΕ ΣΧΕΔΟΝ ΚΑΘΕ ΥΛΙΚΟ. ΚΑΤΑΛΛΗΛΟ ΓΙΑ ΚΟΛΛΗΣΗ ΤΣΙΜΟΥΧΩΝ ΣΕ ΠΟΡΤΕΣ ΚΑΙ ΠΑΡΑΘΥΡΑ ΚΑΙ ΣΕ ΑΥΤΟΚΙΝΗΤΑ, ΓΙΑ ΕΦΑΡΜΟΓΕΣ ΣΕ ΕΡΔΜ/DUTRAL. ΠΟΛΥΜΕΡΙΖΕΤΑΙ ΓΡΗΓΟΡΑ ΣΤΙΣ ΕΠΙΦΑΝΕΙΕΣ ΠΟΥ ΕΦΑΡΜΟΖΕΤΑΙ. ΝΕΑ ΣΥΣΚΕΑΥΣΙΑ ΜΕ ΚΑΠΑΚΙ ΒΕΛΟΝΑΣ. ΑΠΟΤΡΕΠΕΙ ΤΗΝ ΑΠΟΦΡΑΞΗ ΤΗΣ ΑΚΡΗΣ.

Code	Desc.	Cont. g
4110015125	2854	20

## ΕΠΟΞΙΚΗ ΚΟΛΛΑ 2 ΣΥΣΤΑΤΙΚΩΝ



Code	Desc.	Cont. g
4110008800	2854	25ML

## ADER-MIX 2K. Two-component cyanoacrylate adhesive



- Cyanoacrylate adhesive in the bicomponent formulation, paste within seconds almost every type of material and functions as a filler managing to fill voids up to 6 mm thick. Gelatinous consistency which does not drip when applied vertically or under the head.
- Used successfully for repairs and reconstructions in every field of work. Once dried can be worked mechanically, resists the passage of time, weathering, chemicals, does not create marks on the treated parts, transparent color.
- It is used as a standard ultra-fast glue. The packaging in the syringe makes it very practical, not dry leaving its mounted mixer between a use and another. Upon re just change the mixer and is ready for use again.
- Ideal for bonding metals, rubber, wood, paper, cardboard, leather, fabrics and most plastic materials. On difficult plastics, metals and polyolefins must treat the surfaces with our primer for cyanoacrylates code 411 00 17860-4532.
- Supplied with 5 mixers parts per pack. Our mixers parts are compatible with syringes similar to other manufacturers.

Code	Desc.	Content gr.	Confection
4110020010	6323	10	1 syringe + 5 component mixers

Spare Parts	
Article	Code
6324 Mixers	4110020020

### Mixers for ADER-MIX 2K



- Mixers parts for the use of our syringes of cyanoacrylate adhesive bicomponent Ader-Mix 2K. Compatible with similar syringes 10 g of other manufacturers.
- Package of 10 mixers.

Code	Desc.	Pieces per package
4110020020	6324	10

## Activator for cyanoacrylates



Code	Desc.	Content ml	Color
4110017850	4531	200	Transparent

## ΕΠΙΤΑΧΥΝΤΗΣ ΚΥΑΝ/ΚΗΣ ΚΟΛΛΑΣ

- Spray product designed to accelerate the accession process of the hill fast; applicable to all types of cyanoacrylate adhesives (see our cod from 4,110,003,900 to 4,110,015,125).
- Suitable for auto body shops, VI, retail used vehicle, car repair shops, motorcycle, VI, repairs of motor homes and caravans, elettrauto, electricians, termoidraulici, installers, fabricators.
- Allows the use of glues and easy grip even in adverse conditions, such as applications of porous materials, low rates of moisture 'atmospheric or low temperatures. It also prevents the absorption of adhesives low viscosity.
- It does not stain or corrode any type of surface.

### DIRECTIONS FOR USE:

- For best performance bond surfaces should be clean and free of grease.
- Spraying on a surface from a distance of about 20 cm.
- Apply glue on the opposite side to that on which and present the activator and join the pieces for at least 5 seconds by applying a slight pressure, so that the glue outlet.

### CAUTION:

- The performance of the activator dependent viscosity of the adhesive.
- Dries quickly if the viscosity and low (3 sec), if the viscosity and high drying time and less than 10 sec, with gel and' less than 30 sec.

## Epoxy adhesive for metals



## ΕΠΟΞΙΚΗ ΚΟΛΛΑ ΜΕΤΑΛΛΟΥ

- Epoxy adhesive with 2 components charged with metal powders.
- Double 25ml-syringe packaging.
- Suitable to repair, fill and glue: iron, steel, brass, bronze, aluminium, copper, pottery, felt, porcelain, wood, cement and cast iron.
- It allows to restore and recover worn-out parts.
- It polymerises at ambient temperatures.
- Very quick setting, already after 15 minutes it can be handled, the complete drying is reached after ab. 16 hours.
- It can be put on both on horizontal and on vertical surfaces.
- After drying, it can be pierced, threaded, filed, worked with tools and painted.
- It resists temperatures as far as 120°C. the product has a shear resistance higher than 17n/mm after 16 hours.
- It reconstructs damaged or worn-out parts.

Code	Desc.	Content ml	Color
4110015135	2856	25	STEEL

## Superfix - bicomponent epoxy adhesive



- It is a bicomponent adhesive of quick drying.
- Excellent even if the parts don't fit together perfectly.
- Used to weld difficult materials like: glass, porcelain, crystal, pottery, plastic (except for polythene, polypropilene, teflon), marble, alabaster, wood and metal.
- Devoid of solvent and when drying it doesn't shrink.

### HOW TO USE IT

- Melt well in equal quantities the two components of the bonding agent, spread a stratum on one of the surfaces to glue, join the two parts and press till the definitive setting.

Code	Desc.	Content ml
4110008800	2673	25

## Neoprene adhesive



- Polychloroprene adhesive paste for universal use.
- Ideal for bonding plastic laminates, cork, linoleum, rubber foam, synthetic leather telate of wood, plywood, particle board, fiberglass, masonry.
- Strong initial tack, ease and speed of application. It enables movement immediately after the contact between the two glued parts.
- To be applied with a trowel.

Code	Desc.	Cont. KG
4110015400	3010	1
4110015410	3015	5

## Neoprene adhesive



- It is a neoprene adhesive with rapid universal setting.
- For the gluing of foam rubber draw pieces, leather, artificial leathers, sky, fabrics, formica, multilayers, rubber, leather, paperboard, on themselves or on bare painted sheet metal, on glass, wood, ABS, etc.
- Colour: straw-yellow.
- Heat resistance:  $-40^{\circ}\text{C}$   $+90^{\circ}\text{C}$ .
- Already after 15 minutes it guarantees adhesion to coupling, the maximum optimum setting is reached after 48 hours.
- It doesn't drip from vertical surfaces. it doesn't go stringy.
- It can be used with a brush or sprayed with an undercoating gun.

Code	Desc.	Content Kg	Color
4110014790	2770	0,380	YELLOW



## Adhesives Hot Melt



- Hot Melt change stick in several colours.
- Very useful to reduce working times, waste material and pollution.
- They form a very tight gluing allowing to distribute the maximum weight that can be supported along the whole joint.
- Suitable to substitute nails, screws and other fixing forms.
- White and black hot melt are suitable for repairs and gluing of materials like: shoes, luggage, bags, mortise items, furniture, paper, paperoid, wood, imitation leather, fabrics, leather, synthetic leather, transparent rubber, rubber sponge, pu and PVC details.
- Transparent and honey hot melt are suitable for the gluing of plastic materials, wood, pottery, glass, metal, cloth, etc..

Code	Desc.	Color	Conf.	ØxL mm
3930000200	825	TRANSPARENT	10PZ	12x185
3930000300	830	MILK WHITE	10PZ	12x185
3930000400	835	BLACK	10PZ	12x185
3930000500	840	HONEY	1kg (52PZ.)	12x185

## Thermal gun for Hot Melt



- Gun for the hot gluing with hot melt adhesive sticks.
- Light, practical and handy, indispensable for a quick, clean and sure work.
- Melting point of the bonding agent: 206°C.
- Handle with trigger for the automatic feed of the bonding agent.

Code	Desc.	For stick Ø mm
3930000100	203	12

## Professional gun for Hot Melt



- Professional gun for hot melt hot gluing of 12 mm diameter, with electronic regulation of the temperature with PTC technics.
- Mechanical feeding of the bonding agent for a simple and continuous use.
- Basically supplied with a loading station.
- Reduced heating time and possibility of cordless use thanks to the inside thermal accumulator.
- Its use allows quick and resisting gluing in time.

### TECHNICAL CHARACTERISTICS

Feed time: 220V 50Hz  
 Thermal value: Start 500W; rest 16W; work 120W.  
 Bonding agent bars: diam. 12mm x 40/90/120/185.  
 Reached temperature: 210° C.  
 Flow rate: about 12 g/min.

Code	Desc.	For stick Ø mm
3930000600	850	12

## “Fiberkit” Kit for repairs in fibreglass reinforced plastic



- Professional kit made up of bicomponent polyester resin and antiallergic glass fibre.
- Suitable to carry out cloggings of holes, slits, for doublers, moulding on any surface of metal, wood, cement, marble, fibre-glass reinforced plastic, and reinforced plastic panels.
- Particularly useful to repair car sheet metals corroded by rust, roof gutters, boats, surfs, roofs and repairs in general. It can also be used as building material to make storage tanks.
- The kit contains all that is necessary for the working: polyester resin, antiallergic glass fibre (it doesn't irritate hands), catalyst, brush, case for the mixing, 4 disposable gloves.

Code	Desc.	Content
4110011300	2699	Complete kit

## Polyester resin for repairs/makings in fibre-glass reinforced plastic



- Very reactive and highly stabilized polyester resin. characteristics allowing its drying even at temperatures near 0°C.
- To use together with the glass-fibre sheets our code cod. 411 00 11500- 2701.once dried, the resin becomes a medium hard polymer.
- Particularly suitable for the reconstruction and the repair of parts in iron, wood, fibre-glass reinforced plastic, concrete, etc.
- Natural spare product for our fiberkit code cod. 411 00 11300-2699.
- Supplied complete with catalyst for the drying.

Code	Desc.	Cont. ml
4110011400	2700	750

## Glass fibre. Antiallergic



- Rolls of glass fibre, natural spare product for our fiberkit cod. 411 00 11300-2699, or for the use with our polyester resin cod. 411 00 11400-2700 for the making of the desired workings.
- Absolutely antiallergic, it doesn't irritate hand skin, not even the most delicate one.
- 0,5 m<sup>2</sup> packaging.

Code	Desc.	Qty. m <sup>2</sup>
4110011500	2701	0,5

## Poly Mix Fast. Fast polyurethane adhesive for plastic repairs



ΠΟΛΥΟΥΡΕΘΑΝΙΚΗ ΚΟΛΛΑ ΤΑΧΕΙΑΣ ΠΗΞΗΣ. ΚΑΤΑΛΛΗΛΗ ΓΙΑ ΤΗΝ ΚΟΛΛΗΣΗ, ΕΠΙΔΙΟΡΘΩΣΗ ΚΑΙ ΕΝΙΣΧΥΣΗ ΟΛΩΝ ΤΩΝ ΤΥΠΩΝ ΠΛΑΣΤΙΚΩΝ ΥΛΙΚΩΝ, ΟΠΩΣ ΠΡΟΦΥΛΑΚΤΗΡΕΣ, ΑΕΡΟΤΟΜΕΣ, ΠΑΝΕΛ, ΔΕΞΑΜΕΝΕΣ, ΤΑΜΠΛΟ, ΠΟΡΤΕΣ, ΦΩΤΑ, ΚΑΘΙΣΜΑΤΑ, ΤΑΣΙΑ ΤΡΟΧΩΝ ΚΤΛ. ΚΑΤΑΛΛΗΛΗ ΕΠΙΣΗΣ ΓΙΑ ΤΗΝ ΚΟΛΛΗΣΗ ΥΛΙΚΩΝ ΟΠΩΣ ΞΥΛΟΥ, ΠΛΑΣΤΙΚΟΥ ΚΑΙ ΜΕΤΑΛΛΟΥ ΚΑΙ ΣΥΝΔΥΑΣΜΩΝ ΤΟΥΣ. ΤΟ POLY MIX FAST ΕΙΝΑΙ ΜΙΑ ΚΟΛΛΑ ΠΟΥ ΧΡΗΣΙΜΟΠΟΙΕΙΤΑΙ ΜΕ ΤΟ ΠΙΣΤΟΛΙ ΜΕ ΚΩΔ. 345 00 10770 ΚΑΙ ΕΠΙΤΡΕΠΕΙ ΤΗΝ ΑΜΕΣΗ ΚΟΛΛΗΣΗ, ΕΠΙΔΙΟΡΘΩΣΗ ΚΑΙ ΕΝΙΣΧΥΣΗ. ΣΤΕΓΝΩΝΕΙ ΣΤΟΥΣ 20°C ΣΕ 2 ΛΕΠΤΑ ΠΕΡΙΠΟΥ. ΎΤΑΝ ΣΤΕΓΝΩΣΕΙ ΤΟ POLY MIX FAST, ΜΠΟΡΕΙΤΕ ΝΑ ΤΟ ΞΑΝΑΒΑΨΕΤΕ, ΝΑ ΤΟ ΚΑΤΕΡΓΑΣΤΕΙΤΕ, ΝΑ ΤΟ ΤΡΙΨΕΤΕ ΚΑΙ ΝΑ ΤΟ ΣΤΟΚΑΡΕΤΕ. ΣΥΝΟΔΕΥΕΤΑΙ ΑΠΟ ΑΝΑΜΕΙΚΤΗ ΜΕ ΚΩΔ. 4110014717.

Code	Desc.	Qty. ml.	Color
4110014970	2806	50	BLACK

Spare Parts	
Article	Code
2755 Long mixer	4110014715
2755P Short mixer	4110014717

## Poly Mix B. Two-component polyurethane adhesive for repairs slow drying plastic



ΠΟΛΥΟΥΡΕΘΑΝΙΚΗ ΚΟΛΛΑ ΑΡΓΗΣ ΠΗΞΗΣ. ΚΑΤΑΛΛΗΛΗ ΓΙΑ ΤΗΝ ΚΟΛΛΗΣΗ, ΕΠΙΔΙΟΡΘΩΣΗ ΚΑΙ ΕΝΙΣΧΥΣΗ ΟΛΩΝ ΤΩΝ ΤΥΠΩΝ ΠΛΑΣΤΙΚΩΝ ΥΛΙΚΩΝ, ΟΠΩΣ ΠΡΟΦΥΛΑΚΤΗΡΕΣ, ΑΕΡΟΤΟΜΕΣ, ΠΑΝΕΛ, ΔΕΞΑΜΕΝΕΣ, ΤΑΜΠΛΟ, ΠΟΡΤΕΣ, ΦΩΤΑ, ΚΑΘΙΣΜΑΤΑ, ΤΑΣΙΑ ΤΡΟΧΩΝ ΚΤΛ. ΚΑΤΑΛΛΗΛΗ ΕΠΙΣΗΣ ΓΙΑ ΤΗΝ ΚΟΛΛΗΣΗ ΥΛΙΚΩΝ ΟΠΩΣ ΞΥΛΟΥ, ΠΛΑΣΤΙΚΟΥ ΚΑΙ ΜΕΤΑΛΛΟΥ ΚΑΙ ΣΥΝΔΥΑΣΜΩΝ ΤΟΥΣ. ΤΟ POLY MIX B ΕΙΝΑΙ ΜΙΑ ΚΟΛΛΑ ΠΟΥ ΧΡΗΣΙΜΟΠΟΙΕΙΤΑΙ ΜΕ ΤΟ ΠΙΣΤΟΛΙ ΜΕ ΚΩΔ. 345 00 10770 ΚΑΙ ΕΠΙΤΡΕΠΕΙ ΤΗΝ ΑΜΕΣΗ ΚΟΛΛΗΣΗ, ΕΠΙΔΙΟΡΘΩΣΗ ΚΑΙ ΕΝΙΣΧΥΣΗ. ΣΤΕΓΝΩΝΕΙ ΣΤΟΥΣ 20°C ΣΕ 10 ΛΕΠΤΑ ΠΕΡΙΠΟΥ. ΎΤΑΝ ΣΤΕΓΝΩΣΕΙ ΤΟ POLY MIX B, ΜΠΟΡΕΙΤΕ ΝΑ ΤΟ ΞΑΝΑΒΑΨΕΤΕ, ΝΑ ΤΟ ΚΑΤΕΡΓΑΣΤΕΙΤΕ, ΝΑ ΤΟ ΤΡΙΨΕΤΕ ΚΑΙ ΝΑ ΤΟ ΣΤΟΚΑΡΕΤΕ. ΣΥΝΟΔΕΥΕΤΑΙ ΑΠΟ ΑΝΑΜΕΙΚΤΗ ΜΕ ΚΩΔ. 4110014717.

Code	Desc.	Qty. ml.	Color
4110019150	5785	50	BLACK

Spare Parts	
Article	Code
2755 Long mixer	4110014715
2755P Short mixer	4110014717

## Spare mixers



- Spouts universal parts for two-component cartridges 50 ml.
- Indicated as replacement for our codes 411 00 14 970 E 41 00 19150 1.
- Available in short version (85 mm) for products Fluidity 'medium and long (135 mm) to very dense products.
- The short spout, a square section and a particular inner conformation, greatly improves the mixing and the quality of the extruded resin. In addition, the lower capacity 'internal, allows less waste of material than traditional spouts.

Code	Desc.	Type
4110014715	2755	Great
4110014717	2755P	Small

## Strengthening net with film

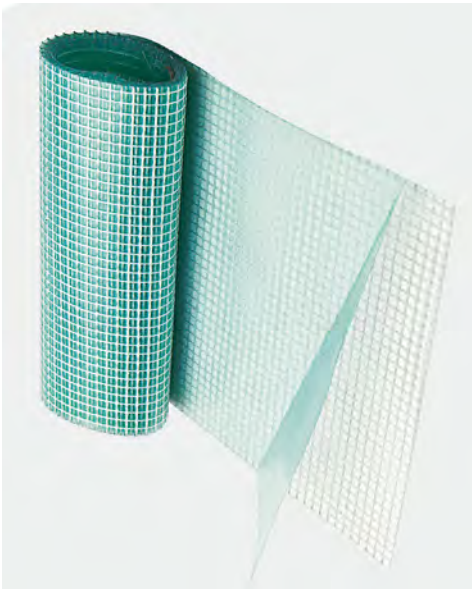

- Strengthening net for plastic repairs, natural spare product of plastik code 411 00 14735-2759 and of all kits for plastic repairs in commerce.
- To put on inside the plastic materials as strengthening before carrying out the repair.
- 1,2 m packaging x h.50 mm.

Code	Desc.	Cont. m	h. cm
4110014980	2808	1,2	5

## Plastic Primer - Spray Primer for plastic repairs



- Primer studied to increase adhesion on plastics of our adhesives for repairs and of all polyurethane and epoxy adhesives present in commerce.
- Indispensable for tpo plastics and all kinds of thermoplastics, it is not necessary for applications on fibreglass reinforced plastic and SMC.
- Put on the perfectly clean and degreased supports.

Code	Desc.	Cont. ml
4110014985	2809	200



## Vinyl glue for wood



- Polyvinylacetate bonding agent in water dispersion, allowing the gluing of hard and soft wood parts, plywood, fibre panels, laminboards and wood by products.
- It doesn't harden the parts and keeps their natural flexibility.
- Semi-quick setting, for any kind of working.
- White-coloured at the time of application, it becomes transparent after the hardening.
- Available in 500 gr packaging with supplying small beak.

Code	Desc.	Cont.
4110015375	2985	5 Kg
4110015390	3000	500 ml

## Vinyl glue for outsides



- Polyvinylacetate bonding agent in water dispersion, allowing the gluing of hard and soft wood parts, plywood, fibre panels, laminboards and wood by-products.
- Of kind D3, for the working on products that must resist bad weather and the damaging action of outside agents.
- It doesn't harden the parts and keeps their natural flexibility.
- Semi-quick setting, for any kind of working.
- White-coloured at the time of application, it becomes transparent after the hardening.
- Available in 500 gr packaging with supplying small beak.

Code	Desc.	Cont.
4110015385	2995	5 kg
4110015380	2990	500 ml

## Polyester putty with glass fibre



- Two component putty, reinforced with glass fibre, for repairing large damages on car bodies even without support, sheet metal, keels on boats, fibreglass, plastic, etc.
- The work must later be finished with polyester putty suited for finishings.
- Small holes of up to one centimetre can be directly filled with the putty. For larger size holes it is necessary to apply a glass fibre reinforcement, our article 411 00 11500-2701, and apply the putty from both sides.
- Easy to apply with plastic or steel spatula, easy to spread, absence of bubbles, quick drying in 20-30 minutes at 20°C.
- Easy workability with coarse sand paper or eccentric lapping machine. We suggest you deeply sand paper the joints and slightly the surfaces.
- Mix with the hardener 1-3%. Time of workability: from 4 to 8 minutes.

Code	Desc.	Cont. KG	Color
4110016220	3920	1	YELLOW

## Fine polyester putty can be sandpapered very easily



- Two component polyester putty, for working on all types of sheet metal, including those galvanized.
- The fine-type granulometry allows for the best levelling of small and large imperfections.
- It hardens quickly during cold weather, and does not create problems of quick hardening on the spatula during hot weather.
- Easy to apply with a plastic or steel spatula, easy to spread, absence of bubbles, quick drying in 20-30 minutes at 20°C.
- Easy workability with fine sand paper after minimum drying hardening time and after 24/18 hours.
- Mix with the hardener 1-3%. Time of workability: from 4 to 8 minutes.

Code	Desc.	Cont. KG	Color
4110016230	3925	1	YELLOW

## Extra fine super soft polyester putty



- Two component polyester putty including all the best qualities that a putty for bodywork should have.
- Compactness and uniformity, excellent anchoring even on galvanized sheet metal, it's softness makes it easy to spread with a spatula, fast drying in little time, easy sand papering even long after it has been applied, no air bubbles, great elasticity.
- Easy to spread with plastic or steel spatula, spreads excellently, fast drying in 20-30 minutes at 20°C. It is possible to apply over any type of base or enamels.
- Easy to sand paper with p120/p320 grains.
- Mix with the hardener 1-3%. Time of workability: from 4 to 8 minutes.

Code	Desc.	Cont. KG	Color
4110016240	3930	1,5	WHITE

## Polyester filler for aluminium panels



- Bi-component polyester filler that brings together the best qualities required for a bodywork filler; compactness and uniformity.
- Excellent anchorage on aluminium panels and also on galvanized panels. Easy and soft spreading, fast quickdrying times, good sandpapering ability even a short while after application, no air bubbles and high elasticity.
- Easy application using a plastic or metal spatula, excellent spreading, quick drying in 25/30 minutes at 20°C. Possibility of applying any type of base coat or enamel.
- Can be sandpapered easily using P120/P320 grain sandpaper.
- Mix with 1% - 3% hardener. Workability time: from 4 to 8 minutes.

Code	Desc.	Cont. KG	Color
4110017360	4325	2,0	ALUMINIUM

## Catalyser for polyester filler



- Exchange catalyser for all types of polyester bodywork fillers.

Code	Desc.	Color	Application
4110017390	4335P	Pink	Polyester bodywork filler

## Spatula for stuccos

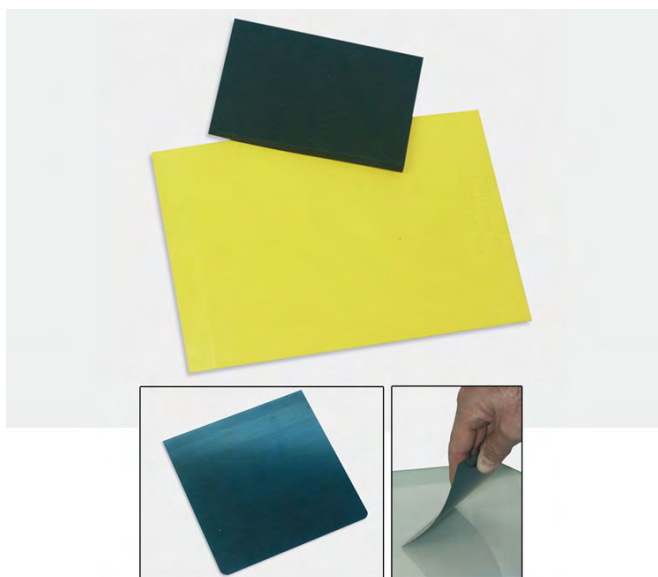

Code	Desc.	Dimensione mm	Material	Type
4430050910	1029/60	120 X 60	-	STEEL SPATULA.
4430050920	1029/80	120 X 80	-	STEEL SPATULA.
4430050930	1029/100	120 X 100	-	STEEL SPATULA.
4430050940	1029/120	120 X 120	-	STEEL SPATULA.
4430050950	1030/80x50	80 X 50	RUBBER	SPATULA IN FLEXIBLE PLASTIC AND RUBBER
4430050960	1031/115x90	130 X 90	PLASTIC	SPATULA IN FLEXIBLE PLASTIC AND RUBBER
4430050970	1031/105x70	105 X 70	PLASTIC	SPATULA IN FLEXIBLE PLASTIC AND RUBBER

## Permanent adhesive spray



- It is a permanent adhesive with rapid effect.
- It allows with just one application the lasting sticking of surfaces like panels, mouldings, coverings and carpets.
- Widely used by carriers (item mark), preparation vehicles (coaches), body shops, garaging caravans and roulottes.
- To avoid the block of the supply valve at the end of the use, turn the canister upside down and spray till the emission of gas only.
- It doesn't stain nor produce wrinkles.

Code	Desc.	Cont. ml	Color
4110014655	2743	400	Transparent

## Spray adhesive that can be traversed



- It is an adhesive allowing an immediate adhesion that can be traversed.
- It is transparent and doesn't stain.
- It produces no wrinkles.
- It is used on synthetic materials, clothes, rolled sections, paper, polystyrene, rubber and felt.
- It resists humidity.
- To avoid the block of the supply valve at the end of the use, turn the canister upside down and spray till the emission of gas only.

Code	Desc.	Cont. ml	Color
4110009600	2681	400	Transparent



## Superflex - Polyurethane sealant for sheet metals



### ΑΡΜΟΚΟΛΛΑ ΠΟΛΥΟΥΡΕΘΑΝΗΣ 290ML

ΕΛΑΣΤΙΚΟ ΚΑΙ ΑΝΘΕΚΤΙΚΟ ΠΡΟΪΟΝ ΣΦΡΑΓΙΣΗΣ ΑΠΟ ΠΟΛΥΟΥΡΕΘΑΝΗ, ΚΑΤΑΛΛΗΛΟ ΓΙΑ ΤΗΝ ΚΟΛΛΗΣΗ ΚΑΙ ΤΗ ΣΥΝΑΡΜΟΛΟΓΗΣΗ ΥΛΙΚΩΝ ΑΠΟ ΜΕΤΑΛΛΟ, ΠΛΑΣΤΙΚΟ, ΞΥΛΟ, ΓΥΑΛΙ Κ.Τ.Λ. ΑΝΘΕΚΤΙΚΟ ΣΤΙΣ ΥΨΗΛΕΣ ΘΕΡΜΟΚΡΑΣΙΕΣ ΤΩΝ ΦΟΥΡΝΩΝ ΞΗΡΑΝΣΗΣ, ΣΕ ΛΑΔΙΑ, ΝΕΡΟ, ΥΔΡΟΓΟΝΑΝΘΡΑΚΕΣ, ΟΞΕΑ, ΒΑΣΕΙΣ, ΔΙΑΛΥΤΕΣ. ΧΡΗΣΙΜΟΠΟΙΕΙΤΕ ΣΕ ΑΜΑΞΩΜΑΤΑ ΑΥΤΟΚΙΝΗΤΩΝ, ΒΙΟΜΗΧΑΝΙΑ, ΦΑΝΟΠΟΙΕΙΑ, ΜΕΤΑΛΛΙΚΕΣ ΚΑΤΑΣΚΕΥΕΣ. ΑΦΟΥ ΣΤΕΓΝΩΣΕΙ, ΣΧΗΜΑΤΙΖΕΙ ΜΙΑ ΕΥΚΑΜΠΤΗ ΚΑΙ ΑΝΘΕΚΤΙΚΗ ΜΑΣΤΙΧΗ ΠΟΥ ΑΠΟΡΡΟΦΑ ΤΟΥΣ ΚΡΑΔΑΣΜΟΥΣ ΚΑΙ ΤΙΣ ΚΙΝΗΣΕΙΣ, ΙΔΙΑΙΤΕΡΑ ΑΝΘΕΚΤΙΚΟ ΣΕ ΣΧΙΣΙΜΑΤΑ ΚΑΙ ΚΑΤΑΠΟΝΗΣΕΙΣ, ΔΕΝ ΕΠΗΡΕΑΖΕΙ ΑΠΟ ΤΙΣ ΚΛΙΜΑΤΙΚΕΣ ΜΕΤΑΒΟΛΕΣ ΚΑΙ ΚΛΙΜΑΤΙΚΟΥΣ ΠΑΡΑΓΟΝΤΕΣ, ΑΝΤΟΧΗ ΣΕ ΘΕΡΜΟΚΡΑΣΙΑ: -400C ΕΩΣ +1200C. ΔΕΝ ΣΥΡΡΙΚΝΩΝΕΤΑΙ, ΔΕΝ ΣΤΑΖΕΙ, ΚΡΕΜΩΔΗ ΣΥΣΤΑΣΗ. ΧΡΩΜΑΤΑ: ΜΑΥΡΟ - ΛΕΥΚΟ - ΓΚΡΙ.

Code	Desc.	Color	Content
4110013000	2716	Grey	Cartridge 310 ml
4110014645	2741	White	Cartridge 310 ml
4110014650	2742	Black	Cartridge 310 ml
4110017820	4528	Grey	Sachet 600 ml
4110017830	4529	Black	Sachet 600 ml
4110017840	4530	White	Sachet 600 ml

Tecnical Features	
Volume change (retirement)	>7%
Maximum load	0,7 Mps
Breaking strength	1,8 N/mm2
Resistenza al taglio	1,5 MPa
Lengthening at breaking	500%
Durezza Shore A	45
Density	1,2 g/ml about
Tempo di formazione pelle a 23°C -50% H.R.	60 min
Velocità di polimerizzazione	About 3 mm after 24 h
Operating temperature	From -30 ° C to + 90 ° C
Aspect	Thixotropic paste
Residuo secco	>93%

## Sealant MS Polymer for sheet plate



### ΠΟΛΥΜΕΡΙΚΗ ΑΡΜΟΚΟΛΛΑ 290ML

Ειδικό σφραγιστικό για το αμάξωμα και όλους τους τύπους πλάκας φύλλου, βάση πολυμερούς ms.

- Ιδανικό για τη στεγανοποίηση όλων των τύπων αρθρώσεων και συνδέσμων σε σώματα αυτοκινήτων, βαρέα οχήματα, σκάφη, κασσίτερο, μεταλλικά σκεύη κλπ.
- Εξαιρετική αντοχή σε νερό, έλαια, οξέα, βάσεις, γλυκόλη, κλπ.
- Μπορεί να εφαρμοστεί με μια βούρτσα, χωρίς να συρρικνώνεται πλήρως, μπορεί να βερνικωθεί αμέσως (υγρό σε υγρή μορφή), η ζύμη είναι ανυπόφορη στις διαφορές θερμοκρασίας.
- Ουδέτερο προϊόν χωρίς διαλύτες και άλλα ουσίες που διαφορετικά θα μπορούσαν να είναι επικίνδυνες την υγεία των χειριστών.

Code	Desc.	Cont. ml	Color
4110014635	2739	290	WHITE
4110014640	2740	290	BLACK
4110016140	3880	290310	GREY

Tecnical Features	
Resistenza alla temperatura	-40 / +90°C
Tempo di formazione pelle (20°C -65% U.R.)	7 - 12 min.
Durezza finale	40 +/- 5 Shore A
Velocità di polimerizzazione (20°C -65% U.R.)	2 mm. / 24 hours
Base	MS Polymer
Aspect	thixotropic paste

## MS Polymer spray sealant



- Spray sealant of ms polymer type.
- Better quality and advantages in terms of applicability, spreading with a brush, creation of embossing, insensitive to temperature changes, can be immediately varnished over wet-on wet (you do not have to wait for it to dry) and up to 48 hours after applying, no shrinking and completely free of isocyanates, low emission of hazardous substances.
- Excellent adherence on all supports as, unrefined sheet metal, varnished or treated with base, etc
- It recreates the original seals on all autos and cargoes in the joints between sheet metals, hoods, motor compartment, trunk, fenders and it can be varnished with any type of varnish on the market.
- Applicable with our pistol cod. 345 00 03919-6006.

### TECHNICAL CHARACTERISTICS

- Base: MS Polymer.
- Consistency: thixotropic paste.
- Colour: beige.
- Polymerization system: with air humidity.
- Speed of polymerization (20°C./65% U.R.): 2-3 mm. in 24 h.
- Resistance to temperature: -40/+90°C.
- Applicability temperature: from +5 to +25°C.

Code	Desc.	Content ml	Color
4110015000	2812	310	BEIGE

## Butyl tape in rolls



- It is a butyl sealing adhesive roll, preformed, dimension mm 1 x mm 10 x mt 6.
- Used to solve the problem of vibrations and of the positioning of plastic details.
- It is waterproof, humidityproof and dustproof.
- It resists ageing.
- Optimum resistance to high and low temperatures -30°C +140°C.
- Perfect adhesion on painted sheet metal.

Code	Desc.	Content
4110014780	2768	5 rolls

## Waterproof filler - plastic sealant in blocks



Code	Desc.	Qty. kg.
4110008700	2672	1

- Single-component mastic in cylindrical blocks, easy to measure and mould, black colour, to seal all air and water seepages, holes, cables and pipes passages, even of big dimensions.
- It sticks to any kind of support, keeping permanently plastic, it doesn't dry.
- For the use, take the desired quantity of product, mould it shortly with the hands, then press it on the hole so that it penetrates and sticks perfectly.

## Butyl sealant in rolls round section



Code	Desc.	Ø mm	Length mt
4110011700	2703	8	4,50

- Preformed sealing tape with round section, in rolls, suitable for the sealing during the assembly of parts of motor vehicles.
- Suitable to carry out seals resistant to air, water, gluing between passivated, painted, zinched sheet metals and glass, wood, plastic materials like EPDM, PE, PP, TPO.

## Acetic silicone 310 ml



TABELLA INDICATIVA DEI CONSUMI		
Giunto spessore X profund. mm.	Consumo al metro lineare	Metri lineari X cartuccia 310 ml.
6x6	36ml.	8,7
8x8	64ml.	4,9
10x10	100ml.	3,1
15x10	150ml.	2,1
20x10	200ml.	1,5

- Acetic acid curing silicone sealant. Fast curing reaction with moisture 'weather.
- Excellent resistance to UV rays and to all atmospheric agents.
- The formulation prevents the formation of microcracks and surface chalking even joints with over 20 years of operation. Permanent elasticity and perfect air and water.
- Size 310 ml. It has a formulation specifically designed for the building and the construction of door and window frames, which ensures a more 'high elastic modulus and a greater fluidity' for better application, while maintaining the excellent characteristics of the base of the product.
- No primer needed for membership.
- USES: In the automotive and naval repair of seals, sealing parts also permanently submerged, the portholes' and hatches.
- In the window frames and plant engineering for the sealing and the 'bonding glass elements, windows, windows, glass blocks, aquariums, art objects, bathroom accessories.

Code	Desc.	Color	Cont. ml
4110005150	2636/310	Black	310
4110005250	2637/310	White	310
4110005350	2638/310	Transparent	310

Tecnical Features	
Odore dopo reticolazione	NONE
Resistenza alle basi	OPTIMUM
Resistenza agli acidi	OPTIMUM
Ritiro	NONE
Maximum operating lengthening	25%
Modulo elastico al 100%	CA. 3.5 KG/CMO
Resistenza a rottura per trazione	12 KG/CMO
Breaking lengthening percent	500%
Durezza Shore A	20
Temperatura di esercizio fino a	-50°C+200°C
Tempo di filmazione a 20°C	5 MIN
Velocità di indurimento dall'esterno verso l'interno CA	4 MIN IN 24 H
Tempo di filmazione a 0°C	45 MIN
Peso specifico	1.045G/CM3
Temperatura di applicazione da/a	-15°C+60°C

## Transparent neutral silicone



- Silicone sealant with neutral oxime curing.
- Incomparable resistance to ageing and atmospheric agents.
- It sticks very good to the most various supports, especially not porous, but also to concrete and wood.
- Permanent elasticity and perfect seal also without primer.
- During polymerisation no substances develop that can damage metals.
- Ideal for seals on aluminium, wood and PVC windows, it can also be used on seals subjected to differentiated movements between the glasses and the draw pieces and the front.
- During the application and the hardening it develops an irritating volatile substance; if inhaled continuously at a high concentration, there can be serious damage to health.

Code	Desc.	Color	Cont.
4110015040	2820	TRANS.	310 ml

Tecnical Features	
Odore dopo reticolazione	NONE
Resistenza agli acidi	OPTIMUM
Resistenza alle basi	OPTIMUM
Resistenza a rottura per trazione (DIN53504)	ca. 1,10 MPa
Maximum operating lengthening	25%
Modulo elastico al 100% (DIN53504)	ca. 0,41 MPa
Breaking lengthening perc. (DIN53504)	ca. 350%
Durezza shore A (DIN53505)	ca. 20
Temperatura d'esercizio	-50°C/+150°C
Tempo di filmazione a 0°C	ca. 40 min.
Tempo di filmazione 23°C	ca. 10 min.
Velocità di indurimento a 23°C	ca. 2 mm in 24 h
Massa volumica (UNI8490)	1,022 g/ml
Temperatura di applicazione da/a	-15°C/+60°C

## Sigillante per infissi MS Polimero trasparente



- Σφραγιστικό με βάση υβριδικό πολυμερές (SiMP) απαλλαγμένο από σιλίκονη, διαλύτες και ισοκυανικά, σχεδιασμένο για σφράγιση και συγκόλληση σε όλους τους τομείς, ιδιαίτερα κατάλληλο για την τοποθέτηση θυρών και παραθύρων με πιστοποίηση CE.
- Αυτός ο τύπος κόλλας μπορεί να χρησιμοποιηθεί σε οποιοδήποτε υλικό για τη στεγανοποίηση κρυστάλλων και αρμών μεταξύ του τοίχου και του πλαισίου του παραθύρου τόσο εξωτερικά όσο και εσωτερικά. Παραμένει μόνιμα ελαστική με την πάροδο του χρόνου, έχει κρυσταλλική διαφάνεια ακόμη και σε πάχος και μπορεί να βαφτεί ακόμη και όταν είναι βρεγμένη σε βρεγμένα με βαφές με βάση το νερό ή διαλύτες.
- Δεν στάζει ακόμα και αν εφαρμόζεται σε κατακόρυφο επίπεδο, έχει εξαιρετική αρχική ρύθμιση ακόμη και σε υγρές επιφάνειες, κολλάει και στεγνώνει ακόμα και κατά τη διάρκεια της βύθισης. Δεν διαβρώνει και δεν είναι επιβλαβές για οποιοδήποτε τύπο υλικού και βαφής ή επικάλυψης.
- Πλεονεκτήματα: παραμένει εύκαμπτο από -40 ° C έως + 90 ° C, προσκολλάται χωρίς τη χρήση αστάρι στα περισσότερα υλικά, προσκολλάται ακόμα και σε υγρές επιφάνειες χωρίς προβλήματα, απορροφά τον ήχο και τους κραδασμούς, εξαιρετική αντίσταση στους ατμοσφαιρικούς παράγοντες, μεταβάλλει το χρώμα και την αντοχή με τις ακτίνες UV, λειτουργεί εύκολα με εξαιρετική αισθητική επίδραση, δεν επιτίθεται στις επιφάνειες, δεν συρρικνώνεται, δεν σχηματίζει φυσαλίδες.
- Τέλεια ανθεκτικό στο νερό, αραιωμένα αλκύλια, καθαριστικά, ασβέστη και μούχλα. Έχει σήμανση CE: F INT, και CE UNI EN 15651/1 πιστοποίηση σήμανσης.

Code	Desc.	Content ml	Color
4110020130	6335	290	Trasparente cristallino

Tecnical Features	
Aspect	Pasta tixotropica
Resistenza termica °C	Da -40°C a +80°C
Allungamento % (ISO 37 DIN 53504)	>400
Temperatura di applicazione	Da +5°C a +40°C
Modulo elastico al 100% N/mm2 (ISO 37 DIN 53504)	>0,6
Resistenza a trazione N/mm2 (ISO 37 DIN 53504)	>2,0
Polimerizzazione	Igroindurente
Indurimento a spessore [mm] Dopo 1 giorno a 23°C e 50% u.r.)	>2,0
Share A (23°C e 50% u.r.)	40-44
Peso specifico (g/cc)	1,06 +/- 0,02
Tempo aperto minuti (23°C e 50% u.r.)	20-30
Natura chimica	SiMP Polimero Silyl Modificato



## Silicone neutro per serramenti



**RETICOLAZIONE  
NEUTRA**

- Sigillante siliconico ideale per l'isolamento dei giunti tra vetro e serramento e tra serramento e parete.
- Basso modulo elastico ed alta adesione su supporti porosi e non es: muratura, metallo, legno o vetro.
- Reticolazione neutra che non genera sostanze acide o basiche che possono aggredire i metalli.
- Collega elasticamente il serramento all'opera muraria assorbendo i movimenti generati da dilatazioni termiche ed igrometriche, scosse ed assestamenti senza distacchi o rotture.
- Caratteristiche invariabili nel tempo.
- Altissima compatibilità con substrati verniciati.
- Indicato per la sigillatura di vetri di serramenti, serramenti su pareti.
- Perfetta tenuta nel tempo all'acqua ed all'aria con conseguente riduzione delle dispersioni di calore.

Code	Desc.	Color	Content ml
4110015041	2821	NERO	310
4110015042	2822	BIANCO RAL9010	310
4110015043	2823	AVORIO RAL1013	310
4110015044	2824	GRIGIO	310
4110015045	2825	NOCE	310
4110015046	2826	VERDE RAL6005	310

Tecnical Features	
Odore dopo reticolazione	NULLO
Modulo elastico al 100% (DIN53504)	ca. 0,32 mpa
Maximum operating lengthening	25%
Resistenza agli acidi	OTTIMA
Resistenza alle basi	OTTIMA
Durezza shore A (DIN53505)	ca. 27
Breaking lengthening perc. (DIN53504)	ca. 500%
Resistenza a rottura per trazione (DIN53504)	ca. 1,00 mpa
Velocità di indurimento a 23°C	ca. 2,5 mm in 24 h
Temperatura d'esercizio	-50°C/+150°C
Tempo di filmazione 23°C	ca. 5 min.
Tempo di filmazione a 0°C	ca. 40 min.
Temperatura di applicazione	-15°C/+60°C
Massa volumica	1,305 g/ml

## Silicone neutro per serramenti metallizzato (colori Raffaello)



**RETICOLAZIONE  
NEUTRA**

- Sigillante siliconico a reticolazione neutra alcolica per l'isolamento e la sigillatura fra vetro e profilo dei serramenti, e fra serramenti e muratura.
- Basso modulo elastico ed alta adesione su supporti porosi e non quali muratura, metallo, legno, PVC e vetro.
- Reticolazione neutra che non genera sostanze acide o basiche che possono aggredire i metalli. Completamente inodore.
- Collega elasticamente il serramento all'opera muraria assorbendo i movimenti generati da dilatazioni termiche ed igrometriche, scosse ed assestamenti senza distacchi o rotture.
- Caratteristiche invariabili nel tempo.
- Altissima compatibilità con tutte le superfici verniciate.
- Perfetta tenuta nel tempo all'acqua ed all'aria con conseguente riduzione delle dispersioni di calore.

Code	Desc.	Color	Content ml
4110016440	4035	Verde metallizzato	310
4110016450	4040	Grigio metallizzato	310
4110016460	4045	Marrone metallizzato	310

Tecnical Features	
Resistenza alle basi	OTTIMA
Odore dopo reticolazione	NULLO
Modulo elastico al 100% (DIN53504)	0,36 N/mm <sup>2</sup>
Maximum operating lengthening	25%
Resistenza agli acidi	OTTIMA
Operating temperature	-40°C/+150°C
Massa volumica	1,305 g/ml
Resistenza a rottura per trazione (DIN53504)	4,0 N/mm
Breaking lengthening perc. (DIN53504)	300%
Durezza shore A (DIN53505)	18
Velocità di indurimento a 23°C	ca. 2,5 mm. in 24 h
Tempo di filmazione 23°C	ca. 15 min.
Tempo di filmazione a 0°C	ca. 45 min.
Temperatura di applicazione	+5°C/+40°C



## Silicone neutro per serramenti metallizzato



- Sigillante siliconico ideale per l'isolamento dei giunti tra vetro e serramento e tra serramento e parete.
- Basso modulo elastico ed alta adesione su supporti porosi e non, come: muratura, metallo, legno o vetro.
- Reticolazione neutra che non genera sostanze acide o basiche che possono aggredire i metalli.
- Collega elasticamente il serramento all'opera muraria assorbendo i movimenti generati da dilatazioni termiche ed igrometriche, scosse ed assestamenti senza distacchi o rotture.
- Caratteristiche invariabili nel tempo.
- Altissima compatibilità con substrati verniciati.
- Indicato per la sigillatura di vetri di serramenti, serramenti su pareti.
- Perfetta tenuta nel tempo all'acqua ed all'aria con conseguente riduzione delle dispersioni di calore.

Code	Desc.	Color	Content ml
4110015055	2835	Alluminio	310

Tecnical Features	
Odore dopo reticolazione	Nulla
Maximum operating lengthening	25%
Resistenza agli acidi	Eccellente
Modulo elastico al 100% (DIN53504)	0,36N/mm <sup>2</sup>
Resistenza a rottura per trazione (DIN53504)	4,0 N/mm
Breaking lengthening perc. (DIN53504)	300%
Durezza shore A (DIN53505)	18
Velocità di indurimento a 23°C	ca. 2,5 mm in 24 ore
Operating temperature	Da -40°C a +150°C
Tempo di filmazione 23°C	ca. 15 min.
Massa volumica	1,305g/ml
Tempo di filmazione a 0°C	ca. 45 min.
Resistenza alle basi	Eccellente
Temperatura di applicazione	+5°C/+40°C

## Neutral silicone for sheet metal



- Silicone sealant with neutral curing particularly suitable on coupling joints in the sheet metal working field.
- Without undercoater it perfectly sticks to aluminium, steel and glass, painted and zinched sheet metal.
- Very good adhesion on painted substrates.
- Not corrosive, single-component, low-modulus, neutral, odourless, with a perfect adhesion on a wide series of substrates and porous surfaces like: cement, asbestos cement, masonry and bricks.
- Extraordinary resistance to atmospheric agents, UV rays and ageing.
- Indispensable in working of gluing and sealing of metal elements in sheet metal working.
- Optimum also in the elastic and impermeable sealing between tubes and plaster, between risers and pottery coverings, between sheet metal coverings and walls, between rakes and chimneys.

Code	Desc.	Color	Cont. ml
4110015050	2830	GREY	310
4110015051	2831	VERY DARK BROWN	310
4110015052	2832	COPPER	310
4110015053	2833	GREY	310

Tecnical Features	
Resistenza alle basi	OPTIMUM
Odore dopo reticolazione	NONE
Resistenza agli acidi	OPTIMUM
Maximum operating lengthening	25%
Breaking lengthening perc. (DIN53504)	ca. 650%
Resistenza a rottura per trazione (DIN53504)	ca. 0,65 MPa
Modulo elastico al 100% (DIN53504)	ca. 0,30 MPa
Durezza shore A (DIN53505)	Cca. 31
Temperatura d'esercizio	-50°C/+150°
Massa volumica (UNI8490)	1,478 g/ml
Temperatura di applicazione da/a	-15°C/+60°C
Tempo di filmazione a 0°C	ca. 45 min.
Velocità di indurimento a 23°C	ca. 2 mm in 24 h
Tempo di filmazione 23°C	ca. 10 min.

## Thermoresistant silicone



- Acetic-curing silicone sealant characterised by a very high resistance to heat.
- High elastic modulus and optimum adhesion to the various kinds of materials.
- Suitable for heads, caps, flanges and piston engine pipings.
- Optimum also for applications in boilers, couplings and thermal system pipes, in heat exchangers, etc..
- Extraordinary resistance to UV rays and atmospheric agents.

Code	Desc.	Color	Cont. ml
4110015063	2841	RED	310

Tecnical Features	
Maximum operating lengthening	25%
Resistenza agli acidi	OPTIMUM
Resistenza alle basi	OPTIMUM
Odore dopo reticolazione	NONE
Temperatura d'esercizio	-50°C/+300°C
Durezza shore A (DIN53505)	ca. 42
Breaking lengthening perc. (DIN53504)	ca. 200%
Resistenza a rottura per trazione (DIN53504)	ca. 2,00 MPa
Modulo elastico al 100% (DIN53504)	ca. 0,85 MPa
Tempo di filmazione a 0°C	ca. 45 min.
Tempo di filmazione 23°C	ca. 5 min.
Velocità di indurimento a 23°C	ca. 3,5 mm in 24 h
Massa volumica (UNI8490)	1,33 g/ml
Temperatura di applicazione da/a	-15°C/+60°C

## Sigillante refrattario T 1000°C



- Mastice monocomponente refrattario, resistente a temperature fino a +1000°C, di consistenza tixotropica che non cola nemmeno se applicato su superfici verticali. Indicato per la sigillatura di giunti su materiali refrattari che sono esposti a fiamme libere.
- Ottimo per la sigillatura di giunti, crepe e fessure all'interno di caldaie, camini, forni, marmitte ed ovunque ci sia la necessita' di una sigillatura in presenza di fiamme.
- Per l'applicazione i sottofondi porosi come calcestruzzo o mattoni devono essere inumiditi, le superfici lisce devono invece essere pulite e ben sgrassate. L'esposizione alla fiamma deve avvenire gradualmente e non prima di 24 ore dall'applicazione, per evitare la formazione di bolle.

Code	Desc.	Color	Content ml
4110017530	4395	Grigio	310

Tecnical Features	
Resistenza a flessione dopo 28 GG (EN 196)	>3 N/mm <sup>2</sup>
Consistency-tendency to slipping (ISO 7390)	0,0 mm (tixotropica)
Velocità di estrusione (MIT 30)	>300 g
Resistenza a compressione dopo 28 GG (EN 196)	>15 N/mm <sup>2</sup>
Indurimento completo	Dopo 1-2 giorni ca.
Massa volumica (UNI 8490/2)	2,2 g/ml
Temperatura di applicazione	Non al di sotto di 0°C
Tempo di reticolazione superficiale (MIT 45)	ca. 30 minuti
Operating temperature	Resiste fino a 1000°C

## Silicone acetico antimuffa



- Sigillante silicónico particolarmente indicato per l'uso su tutti gli impianti igienici e le apparecchiature da cucina - es: bagni, lavabi, docce, acquai, ecc.
- Ottima adesione alla ceramica, al vetro ed alla maggior parte dei supporti non porosi.
- Reticolazione acetica, alto modulo elastico, monocomponente con proprietà fungicide.
- Questo silicone possiede un'altissima resistenza all'acqua bollente e ai detersivi, anche aggressivi, contribuendo così all'igiene ambientale.

Code	Desc.	Color	Content ml
4110015056	2836	TRASPARENTE	310

Tecnical Features	
Odore dopo reticolazione	NULLO
Resistenza alle basi	OTTIMA
Resistenza agli acidi	OTTIMA
Maximum operating lengthening	25%
Modulo elastico al 100% (DIN53504)	ca. 0,28 MPa
Resistenza a rottura per trazione (DIN53504)	ca. 0,75 MPa
Breaking lengthening perc. (DIN53504)	ca. 400%
Durezza shore A (DIN53505)	ca. 18
Temperatura d'esercizio	-50°C/+150°C
Velocità di indurimento a 23°C	ca. 3 mm in 24 h
Massa volumica (UNI8490)	1,262 g/ml
Tempo di filmazione 23°C	ca. 5 min.
Tempo di filmazione a 0°C	ca. 40 min.
Temperatura di applicazione	-15°C/+60°C

## Silicone neutro sanitario



**RETICOLAZIONE  
NEUTRA**

- Sigillante silicónico a reticolazione neutra ad azione fungistatica che previene la crescita delle muffe.
- Ottima resistenza all'acqua, anche bollente, ed al lavaggio con detersivi chimicamente aggressivi, contribuendo, così, all'igiene ambientale.
- Grazie alla reticolazione neutra non sviluppa odori fastidiosi durante l'applicazione, permettendo l'utilizzo in locali chiusi.
- Ideale per la sigillatura impermeabile nei giunti di raccordo nei locali bagno, nelle vasche da bagno, nei box doccia, nei lavelli, tra infissi e rivestimento ceramico, tra pavimento e parete, negli angoli di rivestimenti ceramici murali, nelle sigillature fungo e batteroresistenti delle piscine.
- Non é indicato per incollaggi statici.

Code	Desc.	Color	Content ml
4110015057	2837	BIANCO	310

Tecnical Features	
Odore dopo reticolazione	NULLO
Resistenza agli acidi	OTTIMA
Resistenza alle basi	OTTIMA
Modulo elastico al 100% (DIN53504)	ca. 0,28 MPa
Operating elastic lengthening	25%
Resistenza a rottura per trazione (DIN53504)	ca. 0,75 MPa
Breaking lengthening perc. (DIN53504)	ca. 400%
Durezza shore A (DIN53505)	ca. 18
Temperatura d'esercizio	-50°C/+150°C
Tempo di filmazione a 0°C	ca. 40 min.
Tempo di filmazione 23°C	ca. 5 min.
Velocità di indurimento a 23°C	ca. 3 mm in 24 h
Massa volumica (UNI8490)	1,262 g/ml
Temperatura di applicazione	-15°C/+60°C

## Sigillante acrilico



**SOPRAVERNICIABILE  
PER MURATURA**

- Sigillante usabile nelle giunzioni di telai di porte e finestre con i muri quando il movimento non supera il 10% della grandezza iniziale.
- Perfettamente sopraverniciabile.
- Ideale anche per l'otturazione di fessure e piccole crepe nelle murature, nelle finiture a gesso delle pareti e nella sigillatura del cartongesso.
- Mastice monocomponente a base di resine acriliche in dispersione acquosa.
- Non contiene solventi, praticamente inodore e perfettamente pitturabile.
- Aderisce ai più diffusi substrati del settore edile senza bisogno di primer.

Code	Desc.	Color	Content ml
4110015059	2839	BIANCO	310
4110015175	2863	GRIGIO	310

Tecnical Features	
Resistenza al contatto continuo con l'acqua	SCARSA
Massa volumica (UNI8490)	1,659 g/ml
Temperatura di applicazione	+5°C/+40°C
Tempo di filmazione 23°C	ca. 15 min.
Indurimento completo	ca. 10 gg.
Resistenza alla pioggia battente	dopo ca. 4 h
Temperatura d'esercizio	-25°C/+85°
Durezza shore A (DIN53505)	ca. 30
Breaking lengthening perc. (DIN53504)	ca. 150%
Resistenza a rottura per trazione (DIN53504)	ca. 1,75 MPa
Modulo elastico al 100% (DIN53504)	ca. 1,70 MPa
Maximum operating lengthening	10%
Ritiro	ca. 15%
Resistenza alla colatura	BUONA
Resistenza agli acidi diluiti	BUONA
Resistenza alle basi	BUONA
Verniciabilità	CON PITTURE ALL'ACQUA
Resistenza agli oli e ai carburanti	SCARSA
Resistenza ai solventi	SCARSA

## Sigillante acrilico effetto intonaco



- Sigillante acrilico a base acqua, idoneo per la sigillatura e ripresa di giunzioni, crepe e fori nelle murature. Aderisce su tutte le superfici porose, resiste agli agenti atmosferici dopo la polimerizzazione, perfettamente sopraverniciabile con ogni tipo di pittura.
- Struttura granulata che ricrea ottimamente la superficie dell'intonaco, mimetizzando perfettamente la riparazione.
- Applicazioni su: giunti di movimento fino a max. +/-10%, sigillature di superfici granulose, riparazioni di superfici irregolari, sigillature fra muratura ed infissi.

### MODO D'USO:

- Applicazione: su tutte le superfici porose. Stato della superficie: la superficie deve essere pulita, asciutta libera dall'unto e dalla polvere. Preparazione: pulire il bordo del giunto, rimuovere le parti libere, inumidire il giunto appena prima dell'applicazione del prodotto. Si consiglia un test preliminare di compatibilità. Temperatura di Applicazione: +5°C a +30°C. Non applicare in presenza di gelo o pioggia. Pulire: con acqua subito dopo l'applicazione. Rifinire con: una soluzione saponata prima della formazione della pelle.

### STOCCAGGIO:

- 12 mesi nei propri imballi originali in luogo fresco e asciutto a temperatura compresa tra +5°C e +25°C. Proteggere dal gelo.

Code	Desc.	Color	Content ml
4110016560	4095	BIANCO	310

Distorzione massima consentita	±10%
Resistenza alla temperatura	-20°C/+80°C
Temperatura di applicazione	+5°C/+30°C
Ritiro	Ca. 15%
Tempo di formazione della pelle	Ca. 20 min.
Vulcanizzazione	Essiccamento fisico
Base	Emulsione Acrilica
Consistency	Pasta tixotropica

## Sigillante trasparente cristallino



**SOPRAVERNICIABILE**

- Nuova concezione di sigillante di colore perfettamente trasparente, "cristallino", a base di polimero MS. Qualita' superiori ad un normale sigillante silconico.
- Nuovo modo di sigillare qualsiasi tipo di supporto in maniera perfettamente trasparente, resistente nel tempo all'acqua, l'umidita', gli agenti atmosferici. Assenza totale di ritiro, di sfarinamento e perdite di trasparenza.
- Tixotropico, non cola se applicato su superfici verticali.
- Ideale per sigillature di giunzioni di vetri, per incollaggi di vetri e specchi su vari supporti quali legno, cemento, metalli di ogni tipo.
- Incollaggi legno-legno, legno-metallo, metallo-metallo, muratura, materie plastiche, vetroresina, polistirolo, ecc.
- Assenza totale di odore ed emissioni dannose per l'organismo. Totalmente atossico durante l' applicazione e dopo polimerizzazione.

Code	Desc.	Color	Content ml
4110015960	3290	Cristallino	290

Technical Features	
Durezza	45+/-5 shore A
Polimerizzazione	Con l'umidita' atmosferica
Tempo di indurimento	2mm./24 ore
Fuori polvere	Circa 10 minuti
Base	Polimero MS ibrido
Consistency	Pasta tixotropica

## Adesivo poliuretano D4



**RESISTENTE ALL'ACQUA**

- Indicato per l'incollaggio e la sigillatura di legno e suoi derivati, schiume e pannelli isolanti, telai, mobili, costruzioni in legno e legno-alluminio. ottimo per cianfrinature di infissi.
- Il collante, di colore trasparente, si espande leggermente durante la polimerizzazione.
- Ottima presa su supporti murari quali cemento e mattoni, e su supporti porosi.
- Resistenza alla temperatura da -30°C a +100°C.
- Polimerizza tramite l'umidita' presente nell'aria e sui supporti trattati.

Code	Desc.	Content ml	Color
4110015370	2980	310	trasparente



## MS Polymer assembly adhesive



- Special ms polymer extra-tacky adhesive suitable for any type of surface such as metal, wood, masonry, plastic, marble, natural stone, etc. totally neutral and harmless to the health.
- Thixotropic density that does not drip. the extra-tacky adhesiveness maintains materials in position during the drying period of the adhesive.
- Indicated for gluing skirting boards, wood, chipboard, mdf, cork, insulation panels, profiles, electrical mini-trunking, tiles, mirrors, etc.
- Polymerises by atmospheric humidity. Does not corrode any type of support. Resistant to U.V. rays, atmospheric agents, high and low temperatures and even brackish water. Suitable for outside applications.
- Can be over-painted, even immediately after application.

### USAGE METHOD

- Carefully clean the surface to be glued.
- Cut the nozzle to the required size, apply the product with the appropriate gun and proceed with gluing.

Code	Desc.	Cont. ml	Color
4110016030	3325	290	WHITE

Technical Features	
Velocità di taglio	10 mm./min.
Resistenza al taglio	>1,5 N/mm <sup>2</sup>
Supporto	AlMgSi1
Thickness	2 mm
Resistenza alla rottura	1,9 N/mm <sup>2</sup> . (DIN 53504)
Ritorno elastico	> 75%
Lengthening at breaking	> 600% (DIN 53504)
Maximum deformation	+/- 20%
Resistenza alla temperatura (completamente reticolato)	-40°C. - +90°C.
Modulo elastico al 100%	0,75 N/mm <sup>2</sup> . (DIN 53504)
Peso specifico	1,62 g/ml.
Durezza	50 +/- 5 Shore A
Tempo di formazione pelle	Approx. 10 minuti (20°C./65% U.R.)
Velocità di indurimento	2-3 mm./24 h. (20°C./65% U.R.)
Consistency	Thixotropic paste
Sistema di reticolazione	By atmospheric humidity
Base	MS Polymer

## Primer for sealants



- A specific product for cleaning and preparation of sealing for all difficult surfaces to glue, nonporous, useful for use with silicon type sealants polyurethane, MS Polymer, etc.
- Base formula of pure solvents, which at the same time cleans surfaces perfectly, eliminates traces of grease, old glues, dirt. It greases and prepares the surface, greatly increasing adherence of all sealants.
- It absolutely does not corrode plastic, rubber nor varnishes.
- A great outcome used on all non-porous surfaces as: plastic, raw and varnished metal, aluminium profiles, vehicle bodies.
- It is easy to use: just pour some of the product on a clean rag and wipe it over the surface to be cleaned and sealed.

Code	Desc.	Color	Cont. ml
4110016470	4050	TRANSPARENT	500

## Universal sealant solvent



- Ready to use product for easily cleaning all hardened sealants way from all types of surfaces.
- Efficient on all types of sealants: silicone, acrylic, polyurethanes, and ms polymer, etc.
- Applicable on almost any kind of surface without corroding it: raw and varnished metal ceramic, rolled sections, glass, aluminium. Do not use on nylon surfaces.

### HOW TO USE

- Mechanically remove (with spatula) most of the hardened sealant.
- Spray the product on the remaining material and wait about 10-15 minutes for it to soften.
- Remove the softened sealant with a clean, dry, rough rag.
- If necessary, repeat the procedure until all of the sealant has been removed.

Code	Desc.	Color	Cont. ml
4110016480	4055	TRANSPARENT	400

## Cordoni di tamponamento in polietilene

### CARATTERISTICHE



- Cordoni di tamponamento in polietilene, non assorbente e non degradabile.
- A norma DIN 18540.
- Il campo d'impiego ideale e' l'introduzione del cordone all'interno dei giunti prima dell'applicazione del sigillante.
- Il cordone di tamponamento deve essere utilizzato sempre in combinazione con i sigillanti.

### SETTORI DI UTILIZZO

- Lavori di idraulica, serramentistica, carpenteria, edilizia, falegnameria, manutenzioni in genere.

Code	Descr. <i>Diam. x length</i>	Diam. <i>mm</i>	Length <i>m</i>	Color
4840001210	10x100	10	100	grigio
4840001220	15x100	15	100	grigio
4840001230	20x50	20	50	grigio
4840001240	30x25	30	25	grigio

Lunghezza giunto	Profondità giunto
fino a 10 mm	> 6 mm
da 10 a 20 mm	> 10 mm
oltre 20 mm	metà della larghezza

Materiale	polietilene espanso
Densità (DIN 53420)	ca. 40 Kg/cm <sup>3</sup>
Resistenza alla trazione (DIN 53571)	200-300 KPa (a seconda del Ø)
Allungamento a rottura (DIN 53571)	15%
Temperatura d'esercizio	da -40° C a +60° C
Classe d'infiammabilità	B3

## Schiuma poliuretana elastica per fissaggio infissi

PER  
MONTAGGIO  
SERRAMENTI



**B2**

Secondo  
DIN 4102-1  
EN 13501-1

- Schiuma poliuretana a bassa espansione, termicamente ed acusticamente isolante, studiata specificamente per il fissaggio e l'isolamento dei supporti degli infissi, indicata soprattutto nelle installazioni certificate.
- Aderisce perfettamente alla maggior parte dei supporti: legno, cemento, tutti i metalli, PVC, mattoni, cartongesso, EPS, tegole. Colore verde chiaro.
- La bassa espansione della schiuma permette di non deformare o mettere in tensione i telai e gli infissi, mentre la struttura micro cellulare assicura un'isolamento termico ed acustico elevatissimo.
- Il prodotto essicca a velocità elevata, e dopo solamente 30 minuti raggiunge la sua densità. Può essere in seguito tagliata, lavorata e verniciata normalmente. La schiuma fresca si può togliere con il nostro Solvente per Igroschiuma codice 411 00 15140-2857. La schiuma essiccata può essere tolta solamente in modo meccanico.

Code	Desc.	Content ml	Attachment
4110020150	6337	750	Per pistola

Tecnical Features	
Post espansione (TM 1010)	50 %
Resistenza continua alla temperatura dopo essiccazione	-50/+90 °C
Resistenza alla compressione per brevi periodi dopo essiccazione	-65/+130 °C
Cedimento massimo del giunto sopportabile (TM 1006)	80 mm
Pressione durante la polimerizzazione (TM 1009)	3,2 KPa
Stabilità dimensionale (TM 1004)	+/- 2%
Isolamento acustico (EN ISO 717-1)	60 dB
Resistenza alla compressione al 10% di deformazione (DIN 53421)	3 N/m2
Conduttività termica @ +20°C	0,034 W/(m.k)
Essiccazione completa @ +23°C (ore)	Max 18
Essiccazione completa @ +5°C (ore)	Max 24
Density	15-20 Kg/m3
Resistenza al fuoco DIN 4102-1 / EN 13501-1	B2/E
Diminuzione di volume %	Nessuna
Punto di infiammabilità schiuma essiccata	+400°C
Resistenza a trazione (BS 5241)	10 N/m2
Asciutto per il taglio (minuti)	30-40
Asciutto al tatto (minuti)	10-14

## Schiuma poliuretantica isolante termoacustica

**ALTO  
ISOLAMENTO  
TERMICO E  
ACUSTICO**



**B2**

Secondo  
DIN 4102-1  
EN 13501-1

- Schiuma poliuretantica autoespandente, termicamente ed acusticamente isolante, studiata specificamente l'isolamento sia acustico sia termico in lavori edili e nelle costruzioni in cartongesso.
- Aderisce perfettamente alla maggior parte dei supporti: legno, cemento, tutti i metalli, PVC, mattoni, cartongesso, EPS, tegole. Colore giallo paglierino.
- L'espansione durante l'essiccazione permette di riempire e sigillare ogni tipo di crepa, foro, passaggio presente nelle pareti. Può essere usata per riempire e formare uno strato isolante nelle intercapedini di pareti e solai.
- Il prodotto essicca a velocità elevata, e dopo solamente 40 minuti raggiunge la sua densità. Può essere in seguito tagliata, lavorata e verniciata normalmente. La schiuma fresca si può togliere con il nostro Solvente per Igroschiuma codice 411 00 15140-2857. La schiuma essiccata può essere tolta solamente in modo meccanico.

Code	Desc.	Content ml	Attachment
4110020170	6339	750	Per pistola

Technical Features	
Resistenza alla temperatura per brevi periodi dopo essiccazione	-65/+130 °C
Isolamento acustico (EN ISO 717-1)	60 db
Resistenza continua alla temperatura dopo essiccazione	-50/+90 °C
Conduttività termica @ +20°C	0,035 W/(m.k)
Stabilità dimensionale (TM 1004)	+/-2%
Resistenza al fuoco DIN 4102-1 / EN 13501-1	B2/E
Diminuzione di volume %	Nessuna
Punto di infiammabilità schiuma essiccata	+400°C
Resistenza a trazione (BS 5241)	10 N/m2
Resistenza alla compressione al 10% di deformazione (DIN 53421)	3 N/m2
Asciutto al tatto @ +23°C - 50% H.R. (minuti)	12-16
Asciutto per il taglio @ +23°C - 50% H.R. (minuti)	30-40
Essiccazione completa @ +23°C (ore)	Max 18
Essiccazione completa @+5°C (ore)	Max 24

## Schiuma poliuretantica



**ANTINCENDIO  
EI 120**

- Schiuma poliuretantica monocomponente autoespandente, per sigillature e riempimenti in zone sottoposte alla regolamentazione antincendio fino al livello EI120.
- Ideale per l'isolamento e la messa in sicurezza di attraversamenti di pareti con fasci di tubazioni, per la sigillatura di porte tagliafuoco, per il riempimento di zone destinate a spartifuoco.
- Aderisce senza problemi a tantissimi supporti, quali: pietra, laterizi, metallo, legno, vetro e plastica. Non aderisce su: P.T.F.E., polietilene, polipropilene e sui supporti eccessivamente umidi o bagnati.
- Classificazioni: certificata fino a EI 120 secondo EN 13501-2, classificata B-s2,d0 secondo EN 13501-1, classificata B1 secondo DIN 4102.

Code	Desc.	Content ml	Tipo di erogazione
4110019250	5885P	750	Con pistola

Technical Features	
Tempo di reticolazione superficiale	7 - 10 minuti
Temperatura di applicazione	da +5°C a +40°C
Velocità di indurimento	ca. 60 minuti
Operating temperature	da -40°C a +120°C
Dimensioni delle sigillature	10 - 50 mm
CONSUMPTION	1 bombola da 750 ml per 30 metri lineari di giunto da 1 cm x 10 cm di profondità
Stoccaggio	12 mesi



## Schiuma poliuretana per coppi T



- Schiuma poliuretana monocomponente in bombole aerosol, specifica per fissaggio di tegole e coppi.
- Indicata per l'utilizzo in edilizia, termoidraulica, costruzioni in cartongesso, ecc.
- La schiuma per coppi presenta un'elevata adesività e resistenza agli agenti atmosferici ed allo strappo. Una volta essiccata è impermeabile e compatta, può essere tagliata, carteggiata e modellata a piacimento, verniciata ed intonacata. Si espande pochissimo ed evita lo spostamento ed il sollevamento delle tegole e lo spreco di prodotto per le fuoriuscite laterali.
- Aderisce tenacemente a legno, metallo, calcestruzzo, laterizio, vetro e molti tipi di plastica. può essere usata per: incollare coppi e tegole, fissare installazioni elettriche, isolare tubazioni e tamponare interstizi tra tubi passanti e pareti.
- Classe di reazione al fuoco B2 secondo la norma DIN 4102-1.
- Disponibile con attacco filettato universale per pistola.

Code	Desc.	Content ml	Versione
4110014787	2769P	750	Per pistola

Technical Features	
Resistenza al fuoco	B2
Resistenza ai raggi UV	Scarsa, tende ad ingiallire
Variazione dimensionale lineare a 23°C e 50% UR	<5%
Resistenza a trazione	12 N/cm <sup>2</sup>
Tracciabilità (cordolo del diametro di 20 mm a 23 °C -50% U.R.)	180 minuti circa
Massa volumica (dopo espansione contrastata)	30 - 40 kg/m <sup>3</sup>
Filmazione superficiale a 23°C e 50% UR	15 - 30 minuti
Operating temperature	Da -40°C a +120°C
Color	Marroncino
Temperatura esterna durante l'applicazione	Da +5°C a +40°C

## Hygrofoam



- Polyurethane foam drying with air humidity.
- Optimum adhesion on any surface like: wood, concrete, brick, asbestos cement, metal, glass and plastic.
- Suitable to fix door frames, to seal between window and wall, to soundproof vehicles, to fix electric systems, to isolate pipings, to stop up interstices between passing pipings and walls, to stop up at ceiling cellular cement walls.
- The foam, once dry, can be cut, drilled, sanded, painted, plastered.
- Perfectly impermeable, it resists oils, gasolines, detergents, corrosive agents and atmospheric agents.
- It dries after 15-30 minutes, final drying after 3-8 hours according to the thickness.
- It resists temperatures from -40°C to +100°C.

Code	Desc.	Cont. ml	Tipo di erogazione
4110014720	2756	750	SPRAY +
4110014723	2756P	750	EXTENSION FOR GUN

## Hygro-foam gun



- Professional gun for polyurethane foam.
- Suitable for the use with all screwconnection canisters.
- Easy to disassemble for cleaning and repairing.
- Inside mirror finish.

Code	Desc.
4110015150	2858

## Solvent for Hygro-foam



- Solvent studied purposely for the cleaning of spray guns and of surfaces from the fresh polyurethane foam wastes.
- It doesn't eat into dried foam, not even after a prolonged contact.
- To clean the gun, screw the canister on it and push the trigger lightly to let the foam waste get out, let the solvent work for one or two minutes and spray again till pure solvent comes out again. If necessary, repeat the operation several times. At this point the gun is clean and ready for a new use.
- To clean surfaces, insert the spray on the canister and spray on the area or on the tools to clean.
- Attention: the solvent can melt or discolour treated films (paint, colour, synthetic materials, fabrics, etc.), therefore make a test in a hidden place before the use.

Code	Desc.	Content ml
4110015140	2857	500

## Teflon in roll



- Tape of teflon for sealing threads.
- It resists the temperature sof-190°C + 250°C.
- It allows to form seal gaskets for all piping joints.
- It can be put on metal, plastic, rubber pipings.
- It resists all kinds of aggressive agents like solvents, lubricants, gas, butane, fuels, etc.
- It allows an easy disassembly of pipings because it has the property to keep elastic in time.

Code	Desc.	Width tape mm	Length mt	Thickness mm
4110002200	2608	12	12	0,076
4110002250	2608/19	19	12	0,076

## PTFE sealing tape Professional



- PTFE tape for sigillatura fillets and hydraulic fittings.
- Used in the field of plumbing and heating to seal any type of threaded connection of pipes: hot and cold water, compressed air, and any type of chemical product (even aggressive). resistant to hydrocarbons, solvents, lubricants, fuels, etc.
- Operating temperature  $-60^{\circ}\text{C} + 260^{\circ}\text{C}$ . thickness of the strip constant of 0.2 mm.
- Use on fillets pipes in metal, plastic and rubber.
- Apply on clean threads, exerting slight tension of the belt until constant thickness.
- Given its properties' elastic, allowing easy disassembly of the pipes.

Code	Desc.	Width tape mm	Length mt	Thickness mm
4110017920	4560/12	12	12	0,2
4110017930	4560/19	19	15	0,2

## Sealing tape PTFE use gas



- PTFE tape suitable for sealing threads of the gas pipelines, as well as of threads and hydraulic fittings in general.
- Used in the field of plumbing and heating to seal any type of threaded connection of pipes: hot and cold water, compressed air, and any type of chemical product (even aggressive). Resistant to hydrocarbons, solvents, lubricants, fuels, etc.
- Operating temperature  $-60^{\circ}\text{C} + 260^{\circ}\text{C}$ . Tape constant thickness of 0.1 mm.
- Complies with the UNI EN 751/3 for sealing pipe threads convoglianti gas. Use on fillets pipes in metal, plastic and rubber. Apply on clean threads, exerting slight tension of the belt until constant thickness.
- Given its properties' elastic, allowing easy disassembly of the pipes.

Code	Desc.	Width tape mm	Length mt	Thickness mm
4110017940	4570/12	12	12	0,1
4110017950	4570/19	19	12	0,1

## Universal sealing tape



- Universal sealing tape for plumbing fittings. The only product that can 'replace: pastes, hemp, sealants, tapes PTFE and all anaerobic thread sealants.
- Certificate for use on many types of conduits for: drinking water, heating, steam, methane, propane, alkalis and diluted acids.
- Quick and easy to use, just apply the green side on the thread exerting some pressure, make it adhere to the thread with your fingers and tighten. If necessary to cut before the fillet with a hacksaw.
- It allows the easy disassembly of the fitting even at a distance of years, preventing corrosion.
- It fits on any type of thread and and 'repositionable more' times on the same. Not dirty.
- Compliant ones en751 / 2 (class / arp). 30660 din.

### CARATTERISTICHE TECNICHE E CAMPI D'IMPIEGO (RIFERITI ALLA NORMA UNI EN 751/2 CLASSE A/ARp)

CON GAS	PER PRESSIONI FINO A 5 BAR DA -20° A 70°C.
CON ACQUA	FINO A PRESSIONE 16 BAR A 95°C - FINO A 7 BAR A 130°C.
MATERIALI	TUTTI I MATERIALI, COMPRESO: INOX, MATERIALI PLASTICI, PVC RIGIDO.
FLUIDI	ACQUA POTABILE E DI RISCALDAMENTO, VAPORE, METANO, GPL, ALCOLI ED ACIDI DILUITI.

Code	Desc.	Width tape	Length mt
4110017910	4550	14 mm	15

## Pasta verde per giunti e raccordi filettati



- Mastice per la tenuta dei giunti e raccordi filettati di tutti gli impianti civili ed industriali.
- Ottima aderenza su filettature bagnate e unte, giunzioni svitabili in ogni momento.
- Non tossico, non secca, durevolmente morbido.
- Applicazione a mano o con pennello, insieme a sfilecciature di canapa.
- Temperatura di esercizio: -20°C a +90°C.

Code	Desc.	Weight gr.
4110017620	4440	460



## Canapa extra fine



- Canapa pettinata a trecce.
- La lavorazione extra fine la rende idonea per guarnire tutti i tipi di filettature.
- In confezione in matassine da 250 gr e da 1 kg.

Code	Desc.	Weight gr.
4110017640	4450	250
4110017650	4455	1000

## Sponge rubber with closed cells



- Sponge rubber with closed cellular structure, adhesive, waterproof and unalterable. It allows to get perfect watertight even with low compressibility indexes.
- The optima characteristics do not determine the permanent deformation of the gasket itself.
- The product by itself is tight to liquids and gases even if its surface has no protection films.
- Suitable as thermal, acoustic insulator and light anti-vibration.
- For sections, see the price list.

Code	Descr. Width mm X h mm	Lung. mt
4840000100	10x3	10
4840000200	15x3	10
4840000300	20x3	10
4840000350	50x3	10
4840000400	10x5	10
4840000500	15x5	10
4840000600	20x5	10
4840000700	25x5	10
4840000710	30x5	10
4840000800	15x8	10
4840000900	20x8	10
4840001000	10x10	10
4840001100	20x10	10
4840001110	30x10	10

## Self-expanding, open cell sealing tape



- Open cell, expanding polyurethane foam tape.
- For use in the following sectors: window installations, building, car bodies, transformation and preparation of vehicles.
- For sealing, soundproofing and thermally insulating joints between walls/windows and walls/panels.
- Excellent for sound-proofing and anti-vibration between metal panels. Can be overpainted by any type of paint, even.
- **EASY TO APPLY:** unroll to the length required and apply it to the joint. The tape starts to expand to its maximum expansion after a few minutes.

Code	Desc.	Stato iniziale largh/spess. Mm	Expansion max mm	Length Roll m
4840001350	15/10	15/2	10	12,50
4840001360	15/15	15/3	15	10,00
4840001370	15/20	15/4	20	8,00
4840001380	15/30	15/6	30	5,60
4840001390	15/40	15/8	40	4,30
4840001400	20/20	20/4	20	8,00
4840001410	20/50	15/10	50	3,30

Technical Features	
Storage temperature	From +1C° to +20C°. Does not like freezing temperatures
Durata del materiale	1 year in a dry environment and in the original packing
Flammability class	B2
Thermal conductivity	^10, tr <0,042 W/m X K
Operating temperature	From -40°C to +90°C
Color	Black
Material	Impregnated polyurethane foam
Base	Acrylate with flame retardant additives

## Spray leak detector - Gas leak detector



- Gas and compressed air leak detector in plants.
- Spray the product on the parts to control: if you have a production of foam, you have found the leak.
- The Meccanocar leak detector has also a degreasing action allowing to control even those bigger points like threads and weld beads.
- Used for compressed air system alike: braking systems, flexible and rigid pipings, various pipings, air-conditioning systems, tyres, etc.
- Ideal also on inflammable gas systems like methane, argon, helium, methylne oxide, ethylene oxide.

Code	Desc.	Cont. ml
4110001600	2602	400

## White pulp for silencers



### ΠΑΣΤΑ ΜΟΝΤΑΡΙΣΜΑΤΟΣ ΕΞΑΤΜΙΣΕΩΝ 80 ML

- It is a special pulp for the assembly of the lushing systems, both with tubing joint connection, direct joint connection and flange connection.
  - The product hardens with the heat of the silencer getting the hardness of metal (hardness shore a DIN 53505=42).
  - It is odourless.
  - It resists and eliminates vibrations.
  - Resistance to temperatures higher than 1100°C.
- 
- Degrease and remove the possible rust present.
  - Put on plenty of the product with the special small key to squeeze the tube.
  - To speed up the hardening of the product, let the engine run for some minutes.

Code	Desc.	Cont. ml
4110014500	2731	80

## RTV silicone pastes

### ΦΛΑΝΤΖΟΚΟΛΛΕΣ RTV 200ML

ΚΟΛΛΑ RTV ΤΕΛΕΥΤΑΙΑΣ ΓΕΝΙΑΣ ΜΕ ΒΑΣΗ ΤΗ ΣΙΛΙΚΟΝΗ, ΕΙΔΙΚΗ ΓΙΑ ΚΙΝΗΤΗΡΕΣ ΕΛΑΦΡΟΥ ΚΡΑΜΑΤΟΣ. ΣΤΕΓΑΝΟΠΟΙΕΙ ΣΥΝΔΕΣΜΟΥΣ ΟΠΩΣ ΠΟΛΛΑΠΛΕΣ ΕΙΣΑΓΩΓΗΣ, ΑΝΤΛΙΕΣ ΝΕΡΟΥ ΚΑΙ ΛΑΔΙΟΥ, ΚΑΠΑΚΙΑ ΚΥΛΙΝΔΡΟΚΕΦΑΛΩΝ, ΦΛΑΝΤΖΕΣ ΘΕΡΜΟΣΤΑΤΩΝ, ΚΑΡΤΕΡ ΛΑΔΙΟΥ. ΑΝΘΕΚΤΙΚΗ ΣΕ ΥΨΗΛΕΣ ΘΕΡΜΟΚΡΑΣΙΕΣ ΜΕΧΡΙ +260c, ΣΕ ΛΑΔΙΑ, ΨΥΚΤΙΚΑ, ΓΛΥΚΟΛΗ, ΟΞΕΑ, ΚΑΥΣΙΜΑ Κ.Τ.Λ. ΤΟ ΑΠΟΛΥΤΑ ΟΥΔΕΤΕΡΟ ΠΡΟΪΟΝ ΔΕΝ ΠΡΟΣΒΑΛΛΕΙ, ΔΕΝ ΔΙΑΒΡΩΝΕΙ ΤΑ ΜΕΤΑΛΛΑ ΟΥΤΕ ΤΑ ΚΡΑΜΑΤΑ ΠΟΥ ΧΡΗΣΙΜΟΠΟΙΟΥΝΤΑΙ ΣΤΗΝ ΚΑΤΑΣΚΕΥΗ ΤΩΝ ΣΥΓΧΡΟΝΩΝ ΚΙΝΗΤΗΡΩΝ. ΣΥΜΒΑΤΗ ΜΕ ΟΛΟΥΣ ΤΟΥΣ ΗΛΕΚΤΡΟΝΙΚΟΥΣ ΑΙΣΘΗΤΗΡΕΣ ΚΑΙ ΑΙΣΘΗΤΗΡΕΣ ΛΑΜΔΑ. ΕΙΔΙΚΗ ΣΥΣΚΕΥΑΣΙΑ ΓΙΑ ΕΦΑΡΜΟΓΗ ΑΚΟΜΑ ΚΑΙ ΑΝΑΠΟΔΑ.

Code	Desc.	Color	Content ml
4110016170	3895	Black	200
4110016190	3905	Red	200
4110016580	4097	Grey	200



### ΦΛΑΝΤΖΟΚΟΛΛΑ ΜΑΥΡΗ 80ML



code:

4110013100

## Chemical spray washer - RTV silicone pastes



- Gasket chemical silicone-based, high temperature resistant, of modern generation, for the sealing of pairs in substitution of each type of conventional gasket.
- Available in three versions depending on the type of application, distinguished by color: black, red, or gray.
- All three versions have thixotropic consistency, they do not leak, and do not recline even if applied in vertical positions.
- The special packaging allows the application of the sealant in any position, even in Underhead (for example sealing of the oil sump with the car raised on the deck), and enables the total emptying of the cylinder without waste of product.
- Excellent resistance to all chemicals like oils, fluids and refrigerants, glycol, acids, bases, etc. absolutely not corrosive to each type of metal and alloys used in modern engines.
- Any type of interference on electronic sensors, oxygen sensors, thermostats, etc.

Code	Desc.	Color	Content ml
4110016170	3895	Black	200
4110016190	3905	Red	200
4110016580	4097	Grey	200



## Self-adhesive/anti-vibration PK panels



- It is a self-adhesive panel made up of a special mastic joined with an aluminium sheet.
- Dimensions mm 100x250.
- The main characteristic is that of eliminating noises and vibrations from the car body, reaching a soundproofing 10-15 times higher than the one of traditional antiroars.
- Applicable on interiors doors, bonnets and rear windows.
- Used to stiffen station wagon car roofs.
- For car driving tunnel with rearwheel drive that tend to be noisy.
- To give consistency to the closing of car doors.
- It can be painted on.
- Very used also on caravans, lorry dump-boxes, air-conditioned ducts, etc.
- It resists temperatures between -30°C and + 90°C.
- It is not inflammable, it is not 411 00 14775 corrosive, it is not toxic.

Code	Desc.	Content
4110014775	2767	12 PZ

## Adhesive soundproofing panels

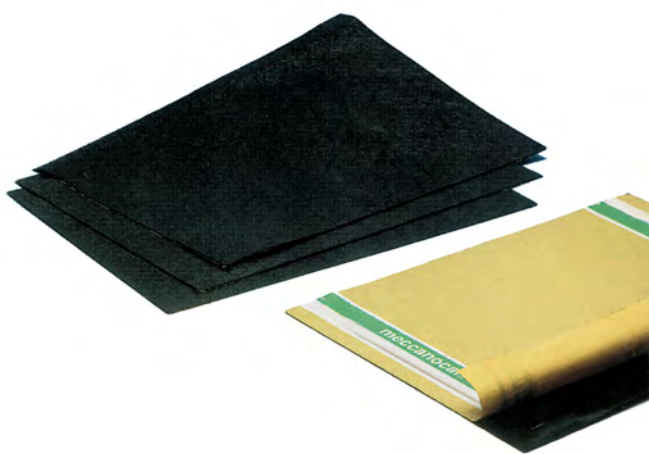

- Panels stickers bituminous material compressed, mm500x400x2 measures.
- Used also in the first plant to soundproof sheet metal and car body parts such as doors, hoods, side panels, floor, Boot floor, spare wheel, wheel, etc ..
- High flexibility and pliability at low temperatures.
- Appearance of the top surface: embossed black. Perfectly painted over.
- Resistance to temperatures from -30 ° C to + 90 ° C.

Code	Desc.	Content
4110014795	2771	10 sheets mm500x400x2



## Wax Protective for tinned materials Transparent and dark



- It is a wax antirust treatment for tinned parts.
- Use on backstays, door insides, bonnets and boots insides, stanchions and empty parts in general.
- It acts widespread thanks to its penetrating power, assuring a valid protection also in the areas of coupling sheet metals.
- Very good resistance to salt mist and corrosion.
- Very good adhesion and plasticity.
- The spray packaging is used for works of finishing touch or of small entity or in the places of difficult access.
- It is also used to substitute graphite for the treatment of end washing of the under bodywork.

Code	Description	Color	Cont.
4110014745	2761	TRANSPARENT	1 lt
4110014750	2762 spray	TRANSPARENT	600 ml
4110014760	2764 spray	DARK	600 ml

## Protective product for under bodywork soundproofing



- It is a synthetic soundproofing anti-metalling protective for under bodywork, side bands, luggage, mudguards, boots, side gaskets, spoiler.
- It dries quickly.
- Very good adhesion, elasticity and resistance to abrasion. It can be painted on after about 1 h.
- It resists heat, atmospheric agents, water and salt.
- It prevents corrosion.
- It doesn't drop nor drip.
- With the tin packaging, using the special pistol and setting its pressure and distance, you get the desired grain.
- Applicable with our pistols cod. 345 00 03905-6001, 345 00 03910-6002, 345 00 03917- 6004.

Code	Desc.	Content Kg	Color
4110014765	2765	1	BLACK

## Anti-stone protective spray



- Anti-metalling protective product based on pure acrylic resins.
- Ideale for the finish of underdoors, spoyler, side coverings, etc.
- It forms a thin, elastic and lightly embossed film, to give finishes similar to the original ones.
- It can be painted on.
- With adjustable valve to control supply.

Code	Desc.	Color	Content ml
4110008500	2670	white	400
4110008600	2671	black	400

## Acrylic anti-stone protector



- It is a single component sound deadener product, permanent against corrosion and impacts due to pebble gravel and rocks.
- Used on side panels, trunk, bottom, under bumpers, inside of doors, wheelhouse, spoiler, engine compartment.
- It creates the original finish of auto parts just as they were originally: Fiat, Alfa, Lancia, Mercedes, Volkswagen, Nissan.
- Excellent elasticity, it adheres on all metal surfaces as well as on some plastics.
- Good resistance to abrasion, to U.V., to saline fog and humidity.
- It does not blanch, does not trickle nor drip.
- It dries quickly, after about an hour.
- It can be varnished over after about 45 minutes.
- It has a high covering power.
- By regulating the pressure on the appropriate pistols and the distance, you can obtain the desired skin.

Code	Desc.	Cont. lt	Color
4110014725	2757	1	BLACK
4110014730	2758	1	WHITE

## Clay polish



Code	Description	Weight
4110018000	4640 - clay polishing	200 gr

- Clay polish for painted surfaces.
- Suitable for car bodies and industrial vehicles.
- It allows to remove easily, fast and secure all types of dirt from the surface to be polished.
- Able to remove resistant dirt such as industrial soot, acid rain remains, overspray, rail dust, residues of braking systems, the sap of plants, insect remains, asphalt, hard water stains and all contaminants Environmental adhering to paint the vehicles.
- Can be used on any surface including painted transparent, glass, chrome, plastic and aluminum.
- Thoroughly cleans the paint finish, the smooth and ready for polishing and final protection. Ideal for use before waxing.
- It allows to obtain high savings in time and cost in the subsequent polishing operations, making latter 'easier and lasting.
- It removes all contaminants that even a washing well executed is able to accomplish.

### • HOW TO USE:

- The surfaces should be clean and dry.
- Give a flattened shape and large clay around the palm of your hand, then apply to the surface to be cleaned and on a clay layer of polish polish NT (4110016600-4115).
- Switch the clay with a little pressure on the areas subject to contamination.
- Rinse or wipe microfibre (code 4460004720 to 4730) the excess polish and repeat pulling and tucking the clay so always use a part spotless.
- Switch to the operations of polishing or protection in the normal manner.
- **WARNING:** If the clay becomes too dirty to be cleaned should be discarded and replaced.
- Always store the clay in cellophane inside his pack when not in use to prevent it from sticking to the container

## N-T water-based rough abrasive gel



- Gel abrasive function mordant, silicone-free, for the elimination of defects in large entities' on all kinds of paint, fresh or dried completely.
- Easy to apply, high property 'abrasion and final gloss, diluted with water. Complete absence of halos. Reduced consumption of product.
- It is easily applied by hand or machine with yellow pad, our Code 342 01 00830-41W5, or wool cap, like our codes 3420102180-73/F, 3420102190-73/L, for greater removal.
- Product very versatile and high performance thanks to the development in nanotechnology.
- Speed 'processing, exceptional results and less waste of product for maximum savings.

Code	Desc.	Cont. Lt
4110017030	4180	1

## N-T water-based medium abrasive gel



- Silicone free medium abrasive gel for eliminating small and medium defects on all types of freshly-painted or completely dry paint.
- Easy to apply, high abrasion and final brilliance properties and dilutable with water. Complete absence of halos. Reduced product consumption.
- Easily applied by hand or by machine using the yellow buffer, our code 342 01 00830-41W5 to remove deep defects or the white buffer, our code 342 01 00840 for light defects, or the wool pad, codes 3420102180-73/F, 3420102190-73/L, for an even better removal.
- Very versatile product with a great performance, thanks to nanotechnology.
- Reduction in work times, excellent results and less product waste for maximum saving.

Code	Desc.	Cont. Lt
4110017040	4185	1



## N-T water-based fine abrasive gel



- Fine abrasive gel, silicone free and silicates, for the elimination of defects of small entities' on all types of paint, fresh or completely dried can be removed with one pass the signs of abrasive P1200 - P2000, type signs of nibs .
- Not dirty seals and plastic parts rough, making it unnecessary to masking.
- It ensures a surface finish of high gloss with a single step, allowing to speed up the processing time.
- Easy to apply, high property 'abrasion and final gloss, diluted with water. Complete absence of halos. Reduced consumption of product.
- It is easily applied by hand or machine with white pad, our Code 342 01 00840-41W2, or wool cap, like our codes 3420102180-73/F, 3420102190-73/L, for better removal.
- Product very versatile and high performance thanks to the development in nanotechnology.
- Speed 'processing, exceptional results and less waste of product for maximum savings.

Code	Desc.	Cont. Lt
4110017050	4190	1

## Gel polish ceramic N-T



- Gel abrasive polishing ceramic nanotechnology.
- Article suitable for body shops and car showrooms.
- Especially product quality, we recommend the use of cars with anti-scratch and transparent high solid on which the normal polish does not perform well, with great savings in time and result performance.
- The gel polish ceramic NT allows you to remove residues of polishing, sanding marks and scratches without leaving marks even on dark colors as fresh or dried.
- Does not heat the body, does not crumble, it is easily removed: one product for all finishes. Easy to apply, high property 'abrasion and final gloss, diluted with water, the complete absence of halos, reduced consumption of product.
- It is easily applied by hand or machine with white pad, our Code 342 01 00840-41W2, or, wool cap type our codes 3420102180-73/F, 3420102190-73/L, for greater removal.
- After polishing, perfecting work and optimal protection of the body, and 'can use our polish PTFE (4110015025 - 2817), or the polish polish NT (Art. 411 00 16600).

Code	Desc.	Content
4110017690	4475	1 Lt.



## Polish based on P.T.F.E.



- Polish based on P.T.F.E of high quality and long last.
- It allows to get a polishing with superior qualities than those of normal polish in commerce.
- It protects from uv rays, oxidation, salt mist, acid rains, industrial wastes and insects.
- High regenerant power.
- Very good brightness effect.
- Usable on car bodies, caravans, lorries, air and shipping sectors.
- Put on by hand with circular movements, then use a clean and dry sponge cloth , or polishing clothn/s art. 446 00 09800-4316.
- Very good results also with a revolving polishing machine.

Code	Desc.	Content It
4110015025	2817	1
4110015035	2819	5

## Polish lucidante per infissi



- Polish rosa di finizione, dalla spiccata morbidezza e facilità di applicazione ed asportazione.
- Toglie in modo rapido ogni graffio, traccia di sporco, macchie ed opacità dalla superficie dei profili in alluminio, PVC ed ogni altro materiale verniciato, lasciando un aspetto lucido e brillante.
- Non rovina nemmeno le vernici più delicate, non sbianca le materie plastiche e non lascia aloni.
- Si applica con un panno morbido e pulito e si toglie con i panni appositi per lucidatura, tipo il nostro articolo cod. 446 00 09800-4316.

Code	Desc.	Content It	Color
4110015305	2905	1	ROSA

## Opacifying pulp



- Water product with high performances.
- Ideal to remove the polish and open the paint pores without sandpapering.
- It leaves no scratches and has no granular components.
- It can be used with steel wool or scotch brite.
- It eliminates greases and silicones.
- It is used as quick and easy preparation to the painting of car bodies and of any painted surface.

Code	Desc.	Cont. Lt
4110015010	2814	1

## Universal spray polish



- Polish universal for polishing metal parts and painted car bodies of motor vehicles.
- Ideal for use on all types of paint: solvent based, water based, epoxy, etc.
- Removes scratches, opacity, dirt more obstinate and long-lasting protection of paint and metals thanks to fine waxes contained in the formulation.

- **HOW TO USE:**
- Shake well before using.
- Spray the product from a distance of about 20 cm.
- Wipe with a soft, clean cloth until the total removal of the product.

Code	Desc.	Cont. ml
4110010600	2691	400

## N-T polish



Code	Desc.	Cont. ml
4110016600	4115	500

- New, P.T.F.E. based sprayable liquid polish, non-abrasive, does not contain silicone, silicates or solvents.
- Ideal for polishing and dry cleaning all painted, rubber and chromed surfaces, etc., of commercial vehicles, cars and motorcycles.
- Easily applicable by hand or machine. Just a light spray of the product, even on dusty parts and a wipe over with a soft cloth or polisher to obtain surfaces perfectly clean with a mirror-like finish and protected over a period of time from atmospheric agents.
- Excellent for removing traces of polishing pastes, halos, traces of dirt, dust.
- Indicated for use in bodywork shops, car and motorcycle shops, concessionaires, car washes and anywhere where a quick and perfect polish is required.

### NANOTECHNOLOGY CHARACTERISTICS

Nanotechnology operates within dimensions defined nanometre = 1 millionth of a millimetre. Through nanotechnology, it is possible to work on materials of greatly reduced dimensions, arriving at the dimensions of a molecule.

**BETTER POLISHING:** The Meccanocar N-T polish obtained by nanotechnology is composed of particles finer than its own and thanks to their reduced dimensions, they work in a much deeper way, penetrating homogeneously inside the paint.

**NO HALOS:** Thanks to the greatly reduced dimensions of the particles, perfect polishing is obtained without halos.

**SAVING:** The very small dimensions of the particles leave much less air spaces between each other thereby making the product much more concentrated. This means that 1 litre of Meccanocar N-T polish in effect is a greater quantity of product.

## Headlight restoration kit 1



### FASI DELLA LAVORAZIONE



- Kit of abrasives and polishing with special gel accessories for the restoration of perfect transparency of the headlights of vehicles polycarbonate, windshields of motorcycles, windshield plastic material, and each surface transparent polycarbonate yellowed and opacified by weather and atmospheric agents.
- Quick and easy to use, easy to apply, suitable for all body shops, machine shops, testing centers, elettrauto, etc. It allows in a short time to restore the original transparency and brightness' of the headlights aged without replacement.
- The kit includes: a range of abrasive discs velcro of assorted grits which allow to remove all the opacity', two gels grinding and polishing to remove the signs of sanding and all the accessories for installation and use by our machines Pneumatic codes from 08120 to 5715 00 418 418 00 random orbital sander and polisher 08130- 5720. And 'available parts for each replenishment kit.
- Contents: 25 discs velcro 400 grit, 800 grit velcro discs 25, 25 diskettes velcro grain in 1500, 25 diskettes velcro grit 2500, two interfaces soft velcro, 1 buffer hard ashlar orange, 1 soft pad ashlar blue, 1 bottle of gel abrasive extra bite for polycarbonate 250 ml, 1 vial of gel polish for polycarbonate 250 ml, 1 roll of thermoplastic tape for masking, 1 cylinder autocristal spray, 1 microfibre cloth for cleaning.
- Supplied in plastic case for easy storage.
- Instructions in the kit.

Code	Desc.
4110018010	4645

Spare Parts		
Article	Code	Description
Dischetto velcrato grana 400	3340500130	75X400
Dischetto velcrato grana 800	3340500160	75X800
Dischetto velcrato grana 1500	3340500190	75X1500
Dischetto velcrato grana 2500	3340500250	75X2500
Interfaccia morbida velcrata 75 mm	3420102200	74
Tampone duro arancio 75 mm	3420102210	75/D
Tampone morbido azzurro 75 mm	3420102220	75/M
Gel abrasivo extra mordente per polycarbonato	4110018020	4650
Gel lucidante per polycarbonato	4110018030	4655
Autocristal spray	4110020510	6368
Panno in microfibra	4460004710	3982/1
Nastro termoplastico	4060300400	38C

## Gel abrasive extra bite for polycarbonate



- Extra abrasive gel mordant specially designed for polishing parts polycarbonate and plastics in general.
- It allows the removal of surface scratches eripristina the original gloss.
- Used to restore our kit headlights code 411 00 18010-4645, it allows removal of grit sanding marks 2500 and prepares the surface for final polishing with gel polish.
- It contains no petroleum products, silicones or mineral abrasives. Does not heat the machined surface, it leaves no streaks, and 'can be diluted with water if necessary. It is easily applied, does not dry, it does not chalk, takes off in a flash without dirtying plastics and seals.
- We recommend the application buffer with hard resin, type our code 02210- 342 01 75 / D.

Code	Desc.	Content ml
4110018020	4650	250

## Gel polish polycarbonate



- Abrasive polishing gel specifically designed for the final polishing of polycarbonate parts and plastics in general.
- It shows the perfect transparency and original shine to the treated parts.
- used for our repair kit headlights code 411 00 18010-4645, it allows final polishing Clueless or halos, removes the signs of treatment with gel extra bite.
- It contains no petroleum products, silicones or mineral abrasives. Does not heat the machined surface, it leaves no streaks, and 'can be diluted with water arises. It is easily applied, does not dry, it does not chalk, takes off in a flash without dirtying plastics and seals.
- We recommend the application with pad in soft resin, type our code 342 01 02220 to 75 / m.

Code	Desc.	Content ml
4110018030	4655	250



## Headlight restoration kit 3



FASI DELLA LAVORAZIONE



Preparazione bicomponente

Prima

Dopo

- Kit of abrasives and special transparent spray with accessories for the restoration of perfect transparency of the headlights of vehicles polycarbonate, motorcycle fairings, windshields a plastic material, and each surface transparent polycarbonate yellowed and opacified by weather and atmospheric agents.
- Quick and easy to use, easy to apply, suitable for all body shops, machine shops, testing centers, elettrauto, etc. It allows in a short time to restore the original transparency and brightness 'of the headlights aged, allowing overcoming dele periodic reviews and a visibility' optimal.
- The kit consists of a range of abrasive discs Velcro of assorted grits which allow to remove all the opacity ', of a specific two-component clear paint spray for restoring the protective layer, and all the accessories for the assembly and operation by the Our pneumatic machine code 418 00 08120- 5715 random orbital sander. and 'available parts for each replenishment kit.
- Contents: 25 discs velcro 400 grit, 800 grit velcro discs 25, 25 diskettes velcro grain in 1500, 25 diskettes velcro grit 2500, two interfaces soft velcro, 1 roll of masking tape thermoplastic, 1 bottle of autocristal spray, 1 microfibre cloth for cleaning, 2 dust cloths for water-based coatings, two cans of transparent two-component spray 200ml. Supplied in plastic case for easy storage.

Code	Desc.
4110019560	6140

Spare Parts		
Article	Code	Description
Dischetto velcrato grana 400	3340500130	75X400
Dischetto velcrato grana 800	3340500160	75X800
Dischetto velcrato grana 1500	3340500190	75X1500
Dischetto velcrato grana 2500	3340500250	75X2500
Interfaccia morbida velcrata 75 mm	3420102200	74
Nastro termoplastico per mascheratura	4060300400	38C
Panno antipolvere blu	4460008525	4130
Trasparente spray bicomponente per policarbonato	4110019510	6115
Autocristal spray	4110020510	6368
Panno in microfibra	4460004710	3982/1

## Transparent polycarbonate headlights



- Protective transparent two-component polyurethane spray, recreates the layer removed by polishing following the elimination of yellowing, scratches and dulling. Used on headlights of motor vehicles, motorcycles and scooters, windshield and skylight transparent, flashlights etc.
- Recommended for use by: body shops, machine shops, testing centers, elettrauto, etc.
- It is easily applied, it dries quickly in the air, in an oven or with UV lamps. The layer obtained can be polished with any type of abrasive paste or polish, it endures in the years to weather and harsh chemicals.
- Cylinder equipped with a valve with adjustable spray fan for better application in every position.
- **HOW TO USE:**
- Remove the cap on the bottom of the tank and remove the metal ring. Insert the metal pin on the hole on the bottom. pull the spool until it stops, then rotate it 360 ° to allow the release of all of the catalyst from the inner vial.
- Shake the bottle for at least three minutes, apply a first coat of transparent lightweight, wait a few minutes to promote adhesion and spray two coats of clear to criss-cross. Allow to dry freely or favor the 'drying with UV lamps or oven.
- Once activated, the transparent has a useful life of about 24 hours. If stored in a refrigerator, the mixed product may also be used after about two days.

Code	Desc.	Content ml
4110019510	6115	200

Tecnical Features	
Tempo di fuori polvere	2 MINUTI
Tempo di essiccazione	TEMPERATURA 20°C, 7 ORE - TEMPERATURA 60°C, 40 MINUTI - CON LAMPADE UV, 25 MINUTI
Lucidatura possibile dopo	TEMPERATURA 20°C, 7 ORE - TEMPERATURA 60°C, 45 MINUTI - CON LAMPADE UV, 30 MINUTI

## Abrasive paste for roughing white metals



- Special paste to effect trimming of metals, usable with the appropriate buffers in cloth, felt or cotton.
- Ideal for working with stationary machines or with manual polishing.
- Fatty compound abrasive first step and rough use with discs: sisal, cotton, tampico or steel brushes.
- Suitable for working on: iron, stainless steel, aluminum, brass, silver, zinc alloy, bronze and copper.

Code	Desc.	Weight Kg.
4110017490	4385/B	1 approximately

## Abrasive paste for polishing metal blue



- Special paste to effect polishing of metals, usable with the appropriate buffers in the cloth, felt or cotton.
- Ideal for working with stationary machines or with manual polishing.
- Average compound grease cutting end, as the first or second step of bases little rough for polishing operations.
- Use with canvas or cloth.
- Suitable for working on: iron, stainless steel, brass, zinc alloy, silver, bronze

Code	Desc.	Weight Kg.
4110017500	4385/A	1 about

## Pink abrasive paste for mirror polishing of metals



- Special paste to effect polishing of metals, usable with the appropriate buffers in the cloth, felt or cotton.
- Ideal for working with stationary machines or with manual polishing.
- Medium compound dry for polishing and final polishing of the surfaces. Use with canvases.
- Suitable for machining of: brass, silver, aluminum, chromium, zinc alloy, bronze and copper.

Code	Desc.	Weight Kg.
4110017510	4385/R	1 approximately

## Galvanizer liquid 99.5%



- Protective coating of pure zinc to 99.5%, for brush or spray finishing and protection of artefacts in iron and steel placed indoors or outdoors.
- The galvanizer Liquid is suitable as a finish, applied on bare metal clean and free from rust, and as anti-rust primer for subsequent applications of synthetic paints. Do not coat the bottom obtained with other types of enamels (nitro, DS, etc.).
- If the coating of the fund obtained with the galvanizer Liquid happens after a long time of its application, it is necessary to thoroughly clean surfaces. Do not sand.
- How to use: the fund to be treated must be perfectly clean, free of rust and degreased. Stir well before application. Apply with a brush, roller or spray. Lay one or two coats of a few minutes, depending on the required strength and environmental conditions.
- The product is ready for use. In case of need it can be diluted to 5% max diluent with a basis of synthetic resin. Dust dry after about 30 minutes. Dry to the touch after about 15 hours.

Code	Desc.	Content ml
4110019930	6315	750

## Cold galvanizer



### ΣΠΡΕΥ ΖΙΝΚ

ΠΡΟΣΤΑΣΙΑ ΠΟΥ ΕΞΑΣΦΑΛΙΖΕΙ Η ΥΨΗΛΗ ΠΕΡΙΕΚΤΙΚΟΤΗΤΑ ΦΥΛΛΙΔΩΤΟΥ ΨΕΥΔΑΡΓΥΡΟΥ. ΑΝΤΟΧΗ ΜΕΧΡΙ ΤΟΥΣ +500°C. Η ΕΝΩΣΗ ΦΥΛΛΙΔΩΤΟΥ ΨΕΥΔΑΡΓΥΡΟΥ ΔΗΜΙΟΥΡΓΕΙ ΕΝΑ ΣΤΡΩΜΑ ΜΕ ΤΟ ΙΔΙΟ ΠΑΧΟΣ, ΠΟΥ ΕΙΝΑΙ ΣΤΑΘΕΡΟ ΚΑΙ ΠΡΟΣΤΑΤΕΥΕΙ, ΤΟ ΟΠΟΙΟ ΜΠΟΡΕΙΤΕ ΝΑ ΒΑΨΕΤΕ ΧΩΡΙΣ ΝΑ ΧΡΕΙΑΖΕΤΑΙ ΚΑΤΩ ΣΤΡΩΜΑ ΒΑΦΗΣ. ΠΟΛΥ ΚΑΛΗ ΚΑΘΟΔΙΚΗ ΠΡΟΣΤΑΣΙΑ ΑΠΟ ΑΤΜΟΣΦΑΙΡΙΚΟΥΣ ΠΑΡΑΓΟΝΤΕΣ. ΚΑΤΑΛΛΗΛΟ ΓΙΑ ΣΗΜΕΙΑΚΗ ΣΥΓΚΟΛΗΣΗ, ΜΕ ΚΑΛΗ ΗΛΕΚΤΡΙΚΗ ΑΓΩΓΙΜΟΤΗΤΑ. ΚΑΤΑΛΛΗΛΟ ΓΙΑ ΤΟ ΡΕΤΟΥΣΑΡΙΣΜΑ Η ΤΗΝ ΚΑΛΥΨΗ ΑΜΑΞΩΜΑΤΩΝ ΑΥΤΟΚΙΝΗΤΩΝ ΚΑΙ ΟΧΗΜΑΤΩΝ, ΣΤΗΝ ΙΣΤΙΟΠΛΟΪΑ ΓΙΑ ΤΗΝ ΚΑΛΥΨΗ ΕΣΩΤΕΡΙΚΩΝ ΚΑΡΙΝΩΝ, ΓΙΑ ΤΗΝ ΠΡΟΣΤΑΣΙΑ ΑΠΟ ΤΟ ΝΕΡΟ ΚΑΙ ΤΟ ΑΛΑΤΙ ΣΕ ΣΩΛΗΝΕΣ, ΔΕΞΑΜΕΝΕΣ, ΠΕΡΙΦΡΑΞΕΙΣ ΚΤΛ..

Code	Desc.	Cont. ml
4110001800	2604	400

## Rust changer



### ΜΕΤΑΤΡΟΠΕΑΣ ΣΚΟΥΡΙΑΣ

ΠΡΟΪΟΝ ΜΕΤΑΤΡΟΠΗΣ ΤΗΣ ΣΚΟΥΡΙΑΣ ΣΕ ΣΙΔΗΡΟΥΧΑ ΥΛΙΚΑ, ΔΗΜΙΟΥΡΓΕΙ ΕΝΑ ΠΡΟΣΤΑΤΕΥΤΙΚΟ, ΣΚΟΥΡΟ, ΣΚΛΗΡΟ ΣΤΡΩΜΑ ΠΟΥ ΠΡΟΣΚΟΛΛΑΤΑΙ ΑΡΙΣΤΑ ΣΤΟ ΥΠΟΚΕΙΜΕΝΟ ΜΕΤΑΛΛΟ ΚΑΙ ΜΠΟΡΕΙ ΝΑ ΒΑΦΕΙ ΜΕ ΚΑΘΕ ΕΙΔΟΣ ΜΠΟΓΙΑΣ. ΕΦΑΡΜΟΖΕΤΑΙ ΜΕ ΒΟΥΡΤΣΙΣΜΑ Η ΨΕΚΑΣΜΟ. ΙΔΑΝΙΚΟ ΓΙΑ ΤΗΝ ΕΠΕΞΕΡΓΑΣΙΑ ΑΜΑΞΩΜΑΤΩΝ ΑΥΤΟΚΙΝΗΤΩΝ, ΚΙΓΚΛΙΔΩΜΑΤΩΝ, ΠΕΡΙΦΡΑΞΕΩΝ, ΚΑΤΕΡΓΑΣΜΕΝΩΝ ΛΑΜΑΡΙΝΩΝ, ΨΥΓΕΙΩΝ ΚΤΛ. ΚΑΘΑΡΙΣΤΕ ΚΑΙ ΑΦΑΙΡΕΣΤΕ ΤΟ ΓΡΑΣΟ ΤΗΣ ΕΠΙΦΑΝΕΙΑΣ, ΕΞΑΛΕΙΨΤΕ ΜΗΧΑΝΙΚΑ ΤΙΣ ΠΙΟ ΕΠΙΜΟΝΕΣ, ΜΗ ΚΟΛΛΗΤΙΚΕΣ ΑΠΟΘΕΣΕΙΣ ΣΚΟΥΡΙΑΣ. ΕΦΑΡΜΟΣΤΕ ΤΟ ΠΡΟΪΟΝ ΚΑΙ ΑΦΗΣΤΕ ΤΟ ΝΑ ΔΡΑΣΕΙ ΓΙΑ 24 ΩΡΕΣ ΠΕΡΙΠΟΥ. ΜΕΤΑ ΒΑΨΤΕ ΤΟ, ΑΝ ΕΙΝΑΙ ΑΠΑΡΑΙΤΗΤΟ. ΓΙΑ ΝΑ ΚΑΘΑΡΙΣΕΤΕ ΤΑ ΕΡΓΑΛΕΙΑ ΜΕΤΑ ΤΗ ΧΡΗΣΗ, ΑΡΚΕΙ ΝΑ ΧΡΗΣΙΜΟΠΟΙΗΣΕΤΕ ΠΙΔΑΚΑ ΝΕΡΟΥ.

Code	Desc.	Cont. ml
4110015275	2883	400

## Zinc chrome protective extra bright



- Protective cold-zinc based, ideal for the protection of the uncovered areas on manufactured hot dip galvanized after fabrication, or for the protection of iron and steel crude from the atmospheric agents.
- **Advantages:** Color very bright and long-lasting.
- Extreme resistance to rain water and brackish water.
- Rapid drying.
- One coat is sufficient to provide protection to the treated structures, and an aesthetically appealing.
- It can be recoated with any type of paint.

Code	Desc.	Cont. ml
4110017520	4390	400

## INOX PRIMER Protective antirust for welding

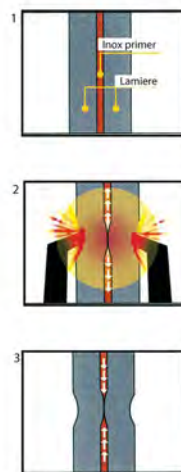

- Rust inhibitor based steel ideal for the protection of steel sheets before welding. Creates a protective layer on the edges of the sheets which will be superposed, and protects against rust and from all types of corrosion, even after the flaps have been welded.
- Suitable for use with any type of electro-dots, a continuous wire, tig.
- It adheres well to metal, withstands high temperatures, it remains elastic over time and will not crack when bent. The product creates a ring around the welding protection that protects the area of marriage.
- Ideal for use in vehicle body before the union of sheet metal, the sheet metal, the metal structures.
- The product, thanks to the appearance of stainless steel type and its properties, can be used as a protective exterior for any artifact or body. Perfectly over with any type of paint.

Code	Desc.	Color	Content ml
4110016160	3890	BRONZED STEEL	400





**CHARACTERISTICS**

- Product forming a protection film similar, also in the appearance, to stainless steel.
- It resists perfectly oxidation, chemical atmospheric agents, water, scratches, etc.
- It can be perfectly painted on, elettroconductive, it can be put on before carrying on spot welding.

**HOW TO USE IT**

- Shake well before using. spray the product from a distance of about 20 cm. in a thin and uniform way.
- At the end of the use, turn the canister upside down and spray till the emission on only gas to clean the valve.

Code	Desc.	Content ml
4110011200	2698	400

**Rust changer**



- Product transforming rust on ferrous materials in a protective dark, hardlayer, perfectly fixed to the underlying metal and that can be painted on with any kind of paint.
- Application through brush or by spray.
- Ideal for the treatment of car bodies, railings, fences, treated sheet metals, radiators, etc.

**HOW TO USE IT**

- Clean and degrease the surface to treat, eliminate the worst and not sticking rust scalings mechanically.
- Put the product on and let it react for about 24 hours. Later, if necessary, paint on it directly.
- To clean the tools after the use it is sufficient to put them under a water jet.

Code	Desc.	Cont. ml	Color
4110011000	2696	250	BROWN

**Pickling gel for stainless**



- Pickling gel for stainless steel surfaces.
- For light metal structural work and heavy.
- Particularly suitable to remove the oxides, the opacity, and the carbon residues formed during the welding.
- **METHOD 'GUIDE:**
- Mix the contents with a stick or a brush made of plastic.
- Then spread a layer of product on the area to be cleaned, where they were previously deleted carbon deposits solder.
- Allow the pickling few minutes on thin sheets, about an hour of molybdenum steels. Rinse thoroughly with water.
- Supplied in a jar of 1 kg. Carefully handle and transfer.

Code	Desc.	Quantity
4110018530	5080	1 Kg

## Splashproof Soldering



- For carpentry, blacksmiths.
- Anti-adhesive liquid that prevents melting of welding sprays on surface around the area to be welded.
- If sprayed on the welding nozzle, it prevents sewing.
- Does not contain silicone or products that prevent adhesion of paints, galvanic treatments, etc.
- Create a corrosion-resistant film until the product comes out removed.
- Usually to be used with our pressure regulator Meccanocar - code: 4110001205

Code	Desc.	Cont. Lt
4110017060	4195	5

## Anti-waste paste



- **CHARACTERISTICS**
- Anti-waste paste based soldering of pure fat in aqueous solution, completely free of silicones and chlorinated.
- It prevents the adhesion of weld spatter in spouts of electric welders.
- Product absolutely nonflammable, vapor almost nonexistent, odorless.
- **HOW TO USE**
- Directly immerse the tip of the welding gun, hot, in the product, which will settle forming a protective film on the outside and the inside of the spout.
- **Suitable for all types of torches jumpers in wire and process tig.**

Code	Desc.	Content gr.
4110015230	2874	450

## Splashproof for welding, water based



- **CHARACTERISTICS**
- Inflammable product water-based protection from weld spatter of welding nozzles and weldments.
- Forms a very thin film and transparent that prevents seizure of the droplets of solder on any media or corrosion by chemical agents.
- Thixotropic product, sprayed from a suitable distance, not drip even when applied to vertical surfaces.
- The product is free of silicones, which allows any subsequent processing such as painting, galvanizing, etc.. without any problem.
- **HOW TO USE**
- Spray the product from a distance of about 20 cm. on the part to be treated, metal, nozzles, spouts, etc.
- **WARNING:** Spray only on areas that will not be welded. Free up the tract that affects the weld.

Code	Desc.	Cont. ml
4110015235	2875	400

## Splashproof solder non-silicone



- It protects surfaces from weld spatter.
- It prevents weld spatter (splinters) to pause on the nozzles of welding.
- It forms a thin film that protects the treated parts by the formation of oxide.
- It decreases the effect of blooming that is created when you operate welding stainless steel.
- Does not contain silicone, it allows for the immediate treatment of the surface welded during painting or galvanizing.
- Allow to dry before processing.

Code	Desc.	Cont. ml
4110014660	2744	400

## Markers for marking



- Permanent markers for marking.
- Suitable for workshops car, motorcycle, marine and VI, auto body shops and VI, elettrauto, carpenters, fabricators, installers.
- Used the following surfaces: Metal, plastic, cardboard, wood, aluminum, stone, glass, protective film, polystyrene, etc.
- Particularly suitable to mark parts of the engine (eg: timing belt and pulleys) during the operation of timing, for the verification of tightening, and for retouches on the bodywork.
- Water resistant.
- Available colors: White, black, yellow, red.
- **INSTRUCTIONS FOR USE:**
- Shake the marker while leaving the cap.
- Remove the cap and press more times the retractable tip to the leakage.
- Repeat depending on usage.

Code	Desc.	Color
4110017900	4536/A	WHITE
4110017901	4536/B	BLACK
4110017902	4536/C	YELLOW
4110017903	4536/D	RED

## High temperatures paint



- Paint based on silicone resins resistant to high temperatures.
- Suitable to paint engines, silencers, exhaust pipes, radiators and heaters.
- It resists till 800°C.
- Particularly suitable on surfaces where heat regularly causes bubbles or cracks in the paint.
- There is no need of films or primer.

Code	Desc.	Color	Content ml
4110004300	2628	dull black	400
4110004400	2629	aluminium	400

## Acrylic body filler spray



- Acrylic body filler spray for correcting imperfections before painting.
- Excellent as a base for all types of paint, such as cling paint on plastic materials, anti-rust paint on untreated iron.
- Can be sandpapered, does not form bubbles, does not flake, even at high temperatures.
- Ensure that the surfaces to be treated are cleaned, degreased and dry before using.

Code	Desc.	Color	Content ml
4110005000	2635	GREY	400

## Spray epoxy putty



- Stucco background filler and leveling imperfections epoxy-based, fast drying, possibility of application wet on wet on any type of sealant, clings perfectly on all types of metal surface such as steel, galvanized sheets, anodized aluminum. Excellent insulation from humidity, excellent protection from rust and oxides.
- Indicated for use in autocarrozzeria, in protective coatings for all manufactured in metal, as pre clinging primer coating by any method.
- Form a compact layer and consisting able to fill small imperfections and sanding scratches. It can be smoothed and sanded already 'after a short time after application. Resists the passage of solvents and antisilicone.
- The special spray head allows you to adjust the intensity and direction of the spray fan. E 'perfectly compatible with all types of paints including water based paints and two-component.
- **HOW TO USE**
- Completely remove the rust from the area to be treated, clean and sand with the grain demand.
- Shake the can well before use, test spray to adjust the spray head and spread some hands from a distance of about 20-25 cm. If necessary cover immediately wet on wet with our acrylic spray filler cod. 411 00 05000-2635.

Code	Desc.	Cont. ml	Color
4110019860	6290	400	Light gray



## Primer for plastics



- Adhesive primer transparent essential for proper adhesion of paint on stucco spray or even hard plastic interior and exterior of vehicles. It is used on bumpers, masks, spoilers, tuning, fiberglass, mirrors, parts of dashboards, finish coatings, etc.
- Suitable for all areas where it is necessary to paint plastic parts up to "hard" or recycled with little gripping power.
- Application simple and fast, fast drying, after ten minutes you can overcoat applying fillers or directly paints of any kind. It does not alter the color of paint to be applied.
- **HOW TO USE:**
- The surface must be clean, degreased and free of dust. Shake the can well before use, spray some coats from a distance of about 20-25 cm.
- Wait for ten minutes drying the product and then proceed to the normal painting.

Code	Desc.	Cont. ml	Color
4110019840	6280	400	Transparent

## Structuring spray plastic



- Clear coat spray structuring effect reconstructing the preparation for painting plastics repaired. Easily recreates the surface roughness of the sheltered areas, making it homogeneous in the surrounding area. It is used on bumpers, masks, spoilers, tuning, fiberglass, mirrors, parts of dashboards, finish coatings, etc.
- Designed for use in body shops and wherever they want to give an effect "rough" to paint anywhere. For use on plastics, metals, wood, etc.
- Operation is simple and fast. The intensity of the rough that you want is easily obtained by varying the spray distance and the amount of product dispensed.
- **HOW TO USE**
- The surface must be clean, degreased and free of dust. Shake the can well before use, spray some coats from a distance of approximately 20-25 centimeters until it reaches the desired orange peel effect.
- Allow time for drying before overcoat. After use invert the can and spray briefly to clear the valve from debris.

Code	Desc.	Cont. ml	Color
4110019850	6285	400	Transparent

## Plastipaint Special paint for plastic parts



- Special acrylic paint suitable for the retouching of plastic parts after the repair.
- Quick drying, it can also be put on directly without using primer, very easy use.
- Make sure before the use that surfaces are clean, degreased and dry.

Code	Desc.	Color	Content ml
4110004900	2634	Black	400

## Touch-up spray paint



- Rapid drying, professional acrylic spray paints, excellent covering, does not drip with an excellent distension on the surfaces treated. Dry to the touch in approximately 10 minutes, completely dry after 1 hour.
- Used for touching-up and painting jobs on cars, motorcycles, heavy vehicles, metal frameworks, window frames, general construction, all types of maintenance.
- Excellent adhesion on any type of metal support: treated and uncovered metal, plastic, wood, glass, general metals.
- As a preliminary to anti-rust and cling treatment, the use of the acrylic filler spray, our code 411 00 05000-2635 is recommended. As a final protection for a long durability of the colour, the use of our transparent shiny or satin paint, code 411 00 17220- 4275.

Code	Desc.	Cont. ml	Color	RAL
4110017070	4200	400	Shiny black	9005
4110017080	4205	400	Opaque black	9005
4110017090	4210	400	Satin black	9005
4110017100	4215	400	Shiny white	9010
4110017110	4220	400	Opaque white	9010
4110017120	4225	400	Yellow	1021
4110017140	4235	400	Fire red	3000
4110017160	4245	400	Iveco chassis red	3009
4110017170	4250	400	Light blue	5015
4110017190	4260	400	Clear electric grey	7035
4110017200	4265	400	Grey	7032
4110017210	4270	400	Iveco chassis grey	7021
4110017220	4275	400	Shiny transparent	-

## Spray spy sanding



- Control acrylic paint with fast drying. Particularly suitable in auto body shops and VI, body transformation, boating.
- The indicator is a system that quickly and easily allows you to highlight the parts not perfectly sanded: imperfections, pores, irregularities and sanding marks.
- It prevents dings once painted.
- Avoid repeat the operations of sanding and filling with lower losses of time for the operator. Perfectly applicable filler and funds.
- A omizzazione Product extra end to ensure a uniform and an ideal result.
- Equipped with Spray Head adjustable fan for a quick convenient application.
- **HOW TO USE:**
- 1. Shake the can well for at least 2 minutes after they well understand the inner spheres.
- 2. Spray a thin coat from a distance of about 20-25 cm from the surface monitored.
- 3. The surface can be sanded after 2/3 minutes.

Code	Desc.	Content ml
4110019200	5835	400

## Vernici per marcatura (tracce)



- Vernici speciali per marcature su tutte le superfici, ad essiccazione rapida, getto fine per segni precisi e senza eccessiva vaporizzazione.
- Ideali per marcature di tracce su tutte le superfici in muratura di impianti elettrici, idraulici, aria condizionata, ecc.
- Non influisce sulla qualità della verniciatura finale delle pareti. dotata di valvola autopulente.

### MODO D'USO

- Agitare bene la bombola tenendola in posizione rovesciata, fino a sentire bene le sfere interne che si agitano, quindi spruzzare sulle superfici da marcare.

Code	Description	Content ml
4110015980	3300 - NERO	400
4110015990	3305 - BLU	400
4110016000	3310 - GIALLO	400
4110016010	3315 - ROSSO	400

## Worksite tracker paints



- High-luminosity, fluorescent and non-fluorescent worksite tracker paints.
- Can be used on outside worksites, resistant to weather, quick drying, even on humid supports.
- They make thin tracks without wasting material, thanks to the special funnel-shaped distributor. safety cap against accidental use.
- Possibility of mounting the can on the extended tracker paint gun holder code 411 00 15660-3140, for a more practical method of painting on the ground.

Code	Desc.	Content ml	Color
4110015600	3110	500	FLUO RED
4110015610	3115	500	FLUO ORANGE
4110015620	3120	500	FLUO YELLOW
4110015630	3125	500	FLUO BLUE
4110015640	3130	500	FUCHSIA
4110015650	3135	500	BLACK
4110015652	3135V	500	FLUO GEEN
4110015654	3135B	500	WHITE

## Extended tracker paint spray holder



- Extended paint spray holder with a small wheel for tracking on the ground.
- Permits tracking on all types of terrain without effort or bending.

Code	Desc.
4110015660	3140

## Internal/external tracker paints



- Special paints for painting tracks on industrial floors, asphalt, etc. Ideal for zones with heavy pedestrian or mechanical traffic.
- Satin finish colour for greater resistance to encrustation, rapid drying, precise functioning without wasting any paint.
- Can be used with the appropriate trolley to effectuate straight lines or with the gun and a stencil for marking walls.

Code	Desc.	Cont. ml	Color
4110015670	3145	500	WITHE
4110015680	3150	500	YELLOW



## Tracker paint trolley



- The four-wheel trolley permits effectuating perfectly straight tracks and to vary the width of the line from a minimum of 40 mm to a maximum of 110 mm.

Code	Desc.
4110015690	3155

## Spray remove graffiti



- Specific product for the removal of graffiti and graffiti on upholstery, interior trim and exterior of vehicles, car bodies, walls, natural stone.
- It penetrates deeply into the body of graffiti dissolving and allowing easy removal.
- Easily removes written made with paint, paint of any kind, permanent markers on porous surfaces, fabrics, carpets, velvet.
- It does not contain silicone or halogenated solvents.
- **CAUTION**
- The use of plastic materials can damage the surfaces, as well as the paints of vehicles.
- It is suitable for use in the bus, buses, trains for removing graffiti from the body, seats, floors, stamping machines, panels, etc.
- **HOW TO USE**
- Shake well before using. spray on the graffiti from a distance of about 10 cm, the product is gelatinous and does not drip even when applied vertically.
- Leave for a few minutes and remove the residue with a damp sponge or a clean cloth. If the stain remains, repeat the operation until the complete removal.
- The time of action of the product depends on the type of stain to remove. On the use of fabric, first try the product on an inconspicuous area to check for any discoloration of the fabric.

Code	Desc.	Content ml	Color
4110017800	4526	400	Transparent



## Stick da ritocco per serramenti



8011 6005 7035 9006 oro 8017 8014 9010 1013 9005

- Stick di vernice acrilica con pennellino incorporato nel tappo.
- Indicato per effettuare ritocchi di graffi e difetti negli infissi in alluminio, legno e PVC.
- Prima dell'utilizzo agitare lo stick col tappo inserito.
- Di rapida essiccazione. resistente alla luce e agli agenti atmosferici.
- Disponibile in varie colorazioni.
- Contenuto 12ml.

Code	Desc.	Color	RAL
4110019460	6065	Bianco perla	1013
4110019465	6070	Bianco	9010
4110019470	6075	Grigio chiaro	7035
4110019475	6080	Marrone noce	8011
4110019480	6085	Marrone seppia	8014
4110019485	6090	Marrone cioccolato	8017
4110019490	6095	Verde	6005
4110019495	6100	Nero	9005
4110019500	6105	Argento	9006
4110019505	6110	Oro	-

## Bottle marker for metals

- Ballpoint markers to write on all metals and any kind of surface, of new conception, differently from metal tubes, like toothpaste, they neither squash nor break and allow to use the product till the end.
- Indestructible packaging, it can be thrown to ground, trampled on and misused in any way without breaking or ruining.
- Self-cleaning cap allowing to have the point clean at each use and to use the product till the last drop.
- Very good to mark also wet surfaces, particularly rough and oily.



Code	Desc.	Cont. ml	Color
4110015215	2871	59	YELLOW
4110015220	2872	59	WHITE

## Antisilicone



- Solvent to remove silicone.
- Very good cleansing power of surfaces before the painting.
- Antistatic effect with reduction of the dust on sheet metals.
- It leaves no waste, it doesn't eat into the paints.
- Ideal for the cleaning of sealants, glues, mastics for windscreens and tar.
- It doesn't bleach black plastics.
- Applicable with cloth tnt ns. art 446 00 09820-4318.

Code	Desc.	Cont. ml
4110015115	2852	5000

## Graduated cases for paints preparation



- Polypropylene cases transparent flexible with special scale to catalyze paints quickly and without any possibility of mistake.
- Very flexible product also at the lowest temperatures, resistant to solvents, reusable.
- Outer scale for catalysis paints in ratio of 2:1, 3:1, 4:1, 5:1. capacity 1 l. and 500 ml.
- Attention: caps supplied separately.

Code	Description	Content ml	For article
4110002600	2612	500	-
4110002700	2613	1.000	-
4110002800	2614 Caps for cases	-	4110002600-2612
4110002900	2615 Caps for cases	-	4110002700-2613

## Filtering funnels of paper with net for paints



- Disposable funnels of paper with net to filter paints.
- Available with net at 850 (medium) or 1.000 meshes (thin).

Code	Desc.	N. mesh	Micron
4110003000	2616	850	226
4110003100	2617	1.000	190

## Emery for valves



- Very pure product with high abrasive power.
- Used for the grinding of the valves of internal combustion engines, bearings and injectors in piston engines.
- There are two kinds of formula of it: coarse-grained and fine-grained for the finishing touch.
- Wastes from grinding can be easily removed with water.
- It can be put on both by hand and by machine.

Code	Description	Content gr.
4110020520	6369 - coarse-fin	200
4110020530	6370 - coarse-grained	200

## Anti-slipping for belts



- Spray product made up by special resins sticking perfectly on the surface of any kind of belt, both flat and trapezoidal, in rubber or various fibres.
- It eliminates completely creakings and prevents slipping due to cold, humidity and the state of wear of the belts themselves.
- It better till 50% more the pulling force of the belts.

### HOW TO USE IT

- Shake well before using, then spray the product uniformly on the whole inside surface of the belt from a distance of about 20 cm., or on a point of the belt moving.

Code	Desc.	Cont. ml
4110001700	2603	400

## Antiwhistle brake



- Special Protective dampener for friction linings, for eliminating the annoying squeaks and whistles of the disc brakes of vehicles.
- The product sets the pads on the clamps avoiding vibration during braking, it prevents bonding over time making it easy disassembly even after many years, protects the treated surfaces from corrosion dirt and weathering.
- **HOW TO USE:**
- Shake the bottle before use. Spray the back of the brake pads before assembly to cover them evenly product, let it dry a few seconds to installation normally.
- Do not spray on discs and friction material.

Code	Desc.	Content ml	Color
4110019540	6130	400	White

## OK START spray



- It assures rapid starting even at very low temperatures both on gasoline and diesel engines.
- In gasoline engines it must be sprayed in the filter or in the air intake of the carburattor; then you start the engine starter lightly accelerating.
- In diesel engines it must be sprayed in the end hub of the injector, without running the preheating of the glow plugs.
- Particularly suitable for agricultural machinery, outboard engines, caterpillar and 2- 4 stroke engines.

Code	Desc.	Cont. ml
4110001000	1859	200



## Pure antifreeze



- Suitable for cooling circuits of car gasoline or diesel engines, motorcycles, industrial vehicles, land movement and marine engines.
- It is a multipurpose antifreeze, it avoids freezing, boiling and protects from corrosion and limestone.
- Absence of toxic components like amines, nitrites, phosphates.
- It doesn't eat into, but it also protects sensitive minerals like copper, brass, soft solders, aluminium and its alloys.
- It causes no fragility neither swelling of rubber sleeves, avoiding leakages or drawing.
- Compatible with hard waters. mixed with water at high saline contents, it avoids scaling and deposits, optimizing the heat exchange.
- High lubricating power on the water pump and on gaskets.
- It reduces leakages by evaporation.

Tabella diluizioni		
% in volume antigelo in acqua	Temperatura di congelamento °C	Temperatura di ebollizione °C
20	-8	102
25	-12	102
30	-18	104
40	-25	106
50	-40	110

Code	Desc.	Content	Color
411000007	7	Canister 5 liters	Blue
411000012	12	200 liter barrel	Blue
4110014890	2790	25 liter canister	Blue
4110015300	2900	50 liter canister	Blue

## Antifreeze ready for use



- Permanent antifreeze for cooling systems of motor vehicles, all-season, prevents freezing and raises the boiling point.
- Used by all machine shops for top-up and drain fluids original on motorcycles, cars, trucks, marine, machines in general.
- Formulation free from nitrites and amines, ecological, reduces the formation of scale even if used with particularly hard water, increases the heat transfer promoting the cooling of the engine, increases the boiling point of the coolant, protects against corrosion and rust all rubber parts and any metal, compatible with aluminum engine blocks.
- Compatible with all types of antifreeze currently used.
- The product 'already' mixed and ready to use in different shades and colors used in the original equipment manufacturers of vehicles. It allows top-ups without changes in the original color
- Antifreeze Meccanocar meets or exceeds the following specifications:
  - CUNA NC 956.16
  - ASTM D 3306
  - SAE J 1034

Code	Desc.	Content	Type
4110008200	2667	1 liter bottle	Antifreeze ready -40 ° C - 50% blue
4110014895	2791	25 liter canister	Antifreeze ready -40 ° C - 50% blue
4110018040	4660	Canister 5 liters	Antifreeze ready -40 ° C - 50% green
4110018050	4665	Canister 5 liters	Antifreeze ready -18 ° C - 30% blue
4110018060	4670	25 liter canister	Antifreeze ready -18 ° C - 30% blue
4110018070	4675	Canister 5 liters	Antifreeze ready -18 ° C - 30% green
4110000050	50	Canister 5 liters	Antifreeze ready -10 ° C - 20% blue



## Antifreeze long life

### Antifreeze long life -40°C G12 4kg



4110017750

4110016400

Code	Desc.	Content	Color
4110017750	4000	Canister 4 liters	BLUE
4110016400	4680	Canister 4 liters	RED

ΥΨΗΛΗΣ ΠΟΙΟΤΗΤΑΣ ΣΥΜΠΥΚΝΩΜΕΝΟ ΑΝΤΙΨΥΚΤΙΚΟ ΚΑΙ ΑΝΤΙΘΕΡΜΙΚΟ ΥΓΡΟ ΑΙΘΥΛΕΝΟΓΛΥΚΟΛΗΣ. ΠΑΡΑΣΚΕΥΑΖΕΤΑΙ ΣΥΜΦΩΝΑ ΜΕ ΤΙΣ ΑΠΑΙΤΗΣΕΙΣ ΤΩΝ ΣΗΜΑΝΤΙΚΟΤΕΡΩΝ ΑΥΤΟΚΙΝΗΤΟΒΙΟΜΗΧΑΝΙΩΝ. ΔΕΝ ΠΕΡΙΕΧΕΙ ΝΙΤΡΩΔΗ ΟΥΤΕ ΑΜΙΝΕΣ, ΕΙΝΑΙ ΟΙΚΟΛΟΓΙΚΟ, ΜΕΙΩΝΕΙ ΤΟ ΣΧΗΜΑΤΙΣΜΟ ΑΛΑΤΩΝ, ΑΚΟΜΑ ΚΑΙ ΑΝ ΧΡΗΣΙΜΟΠΟΙΕΙΤΑΙ ΣΕ ΣΥΝΔΥΑΣΜΟ ΜΕ ΙΔΙΑΙΤΕΡΑ ΣΚΛΗΡΟ ΝΕΡΟ, ΕΝΙΣΧΥΕΙ ΤΗ ΜΕΤΑΦΟΡΑ ΘΕΡΜΟΤΗΤΑΣ, ΒΕΛΤΙΩΝΕΙ ΤΗΝ ΨΥΞΗ ΤΟΥ ΚΙΝΗΤΗΡΑ, ΑΥΞΑΝΕΙ ΤΟ ΣΗΜΕΙΟ ΒΡΑΣΜΟΥ ΤΟΥ ΨΥΚΤΙΚΟΥ, ΠΡΟΣΤΑΤΕΥΕΙ ΑΠΟ ΤΗ ΔΙΑΒΡΩΣΗ ΚΑΙ ΤΗ ΣΚΟΥΡΙΑ ΤΑ ΛΑΣΤΙΧΕΝΙΑ ΤΜΗΜΑΤΑ ΚΑΘΕ ΜΕΤΑΛΛΙΚΟΥ ΕΞΑΡΤΗΜΑΤΟΣ, ΕΙΝΑΙ ΣΥΜΒΑΤΟ ΜΕ ΤΑ ΜΠΛΟΚ ΚΙΝΗΤΗΡΑ ΑΠΟ ΑΛΟΥΜΙΝΙΟ ΚΑΙ ΑΛΛΑ ΕΛΑΦΡΑ ΚΡΑΜΑΤΑ ΠΟΥ ΠΡΟΤΕΙΝΕΤΑΙ Η ΠΡΟΔΙΑΓΡΑΦΗ ΤΥΠΟΥ G12. ΤΑ ΕΙΔΙΚΑ ΟΡΓΑΝΙΚΑ ΠΡΟΣΘΕΤΑ ΠΟΥ ΥΠΑΡΧΟΥΝ ΣΤΗΝ ΠΡΩΤΗ ΥΛΗ ΚΑΘΙΣΤΟΥΝ ΤΟ ΠΡΟΪΟΝ ΑΠΟΛΥΤΩΣ ΑΒΛΑΒΕΣ ΓΙΑ ΤΑ ΥΛΙΚΑ ΑΠΟ ΤΑ ΟΠΟΙΑ ΕΙΝΑΙ ΚΑΤΑΣΚΕΥΑΣΜΕΝΟΙ ΟΙ ΣΥΓΧΡΟΝΟΙ ΚΙΝΗΤΗΡΕΣ. ΜΠΟΡΕΙ ΝΑ ΣΥΜΠΛΗΡΩΘΕΙ ΣΕ ΗΔΗ ΥΠΑΡΧΩΝ ΑΝΤΙΨΥΚΤΙΚΟ ΧΩΡΙΣ ΝΑ ΜΕΤΑΒΑΛΕΙ ΤΟ ΑΡΧΙΚΟ ΧΡΩΜΑ. ΕΙΝΑΙ ΣΥΜΒΑΤΟ ΜΕ ΟΛΟΥΣ ΤΟΥΣ ΤΥΠΟΥΣ ΑΝΤΙΨΥΚΤΙΚΟΥ ΠΟΥ ΧΡΗΣΙΜΟΠΟΙΟΥΝΤΑΙ ΣΗΜΕΡΑ

#### ΚΑΘΑΡΙΣΤΙΚΟ ΨΥΓΕΙΟΥ

### Descaling liquid for radiators



Code	Desc.	Content ml
4110013400	2720	250

#### ΣΤΕΓΑΝΟΠΟΙΗΤΙΚΟ ΨΥΓΕΙΟΥ

### It seals radiator fluid



Code	Desc.	Content ml
4110013300	2719	250

## Antifreeze for braking systems



- Specific liquid for the protection from freezing conditions and lubrication of the pneumatic system on all heavy trucks; like: braking systems, door opening systems, etc.
- The product can be used during all seasons. If used regularly it protects the pneumatic system from rust and lubricates all moving parts.
- It protects without causing damage to rubber parts or synthetic materials.

Code	Desc.	Content ml
4110016270	3945	1000

## Remover for gaskets



- It removes gaskets and paints with maximum easiness.
- It removes by dissolution chemical gaskets from engine heads, oil pumps and silencers.
- It removes anaerobic and cyanoacrylate products.
- It removes paper gaskets, fibres and paints, resins, fillers, tar, grease, and dry oil as well.
- It doesn't drip from vertical surfaces.
- Used on metal, alloys, wood, glass, pottery, polythene and polypropylene, it doesn't damage surfaces.

Code	Desc.	Cont. ml
4110004100	2626	400

## Hermetic for gaskets



- Adhesive with high adhesive strength suitable for securing and sealing any kind of traditional gasket.
- Great even on irregular surfaces.
- Used on engine headings and monoblocks, in the assembly of machined surfaces, threaded connections, hydraulic pumps, flanges, threaded pipes of cooling and heating systems.
- Resists water, antifreeze, petrol, oil and hydrocarbons.
- It applies to brush on previously clean surfaces.

Code	Desc.	Cont. ml
4110000200	1000	100

## Protective poly battery blue



- Special grease antioxidation and antisolfatazione for electrical contacts, clamps and the battery poles, prevents the formation of the oxide and corrosion even in the presence of atmospheric agents and saline environments. Especially indicated in the marine industry.
- Long life, its color allows immediately evaluating its presence or absence. It withstands high temperature and the action of corrosive agents. It improves the transmission of electricity, extends battery life and prevents overheating of the electrical contacts.

### • HOW TO USE:

- First clean the terminals or contacts from any oxidation already formed. Shake well and spray it on the contacts by a distance of about 20 cm so as to form a homogeneous layer.
- On the terminals on the battery and electrical contacts spray the product before and after the mechanical coupling, so that the product is also present within the joint.

Code	Desc.	Content ml
4110019520	6120	200

## Protection for battery poles red



- Antiacide grease for battery charging clips. Colour red.
- It prevents sulfation and corrosion.
- Very good also on copper or bronze lugs.
- It doesn't lose its natural consistency and keeps unchanged its lubricating power.
- It avoids resistences due to contact and prevents voltage drops.

Code	Desc.	Cont. ml
4110015520	3070	200

## IDROREP dielectric waterproofer



- Product with high waterproof qualities. it eliminates humidity from all electric contacts, it prevents it from forming again and restore connections.
- It waterproofs and prevents any oxide forming on caps, plug electric wires, battery poles and any other electric part.
- It resists high voltages.

### HOW TO USE IT

- Shake the canister well before using. spray from a distance of about 20 cm. on the parts to treat.

Code	Desc.	Content ml
411000910	1851	400

## Laser spray - degreaser for contacts



- It is a dry cleaner for electric contacts.
- Suitable for the cleaning of electric and electronic equipments like: breadboards, switches, bearings, lenses and medical equipments, relais, branch exchanges, cables.
- It quickly and easily penetrates in small holes and interstices evaporating in a few seconds.
- It works under any condition of humidity and temperature.
- It doesn't eat into paints, resins, plastics and elastomers.
- It is colourless and odourless.
- It cleans by eliminating oxide layers, oils, resins and adhesives.
- It protects from corrosion.
- It resists till 25.000 volts.
- Not to be used on systems under tension.

Code	Desc.	Cont. ml
4110010900	2695	400

## Liquid for brakes - DOT 4



- Fluid for hydraulic brakes.
- It doesn't eat into rubber parts.
- It gets through the specific SAE J 1703/80, FMVSS116 DOT4 and DOT3 ISO. 4925
- Boiling point 265°C.
- It eliminates the phenomenon of "vapor lock" following the overheating of mechanical parts and therefore of the fluid, avoiding the idle stroke of the foot-brake pedal.
- It can be mixed with all kinds of similar products.

Code	Desc.	Cont.
4110013500	2721	250 ml
4110013800	2724	5 lt
4110014665	2745	1 lt



## Liquid for brakes - DOT5



- Special fluid on synthetic base, it doesn't eat into rubber parts.
- Prepared to satisfy the requirements of the "department of transportation DOT5", providing for a better resistance to humidity compared to the traditional kinds.
- Used in competitions and wherever you desire better performances as for quickness of response of the brake pedal and resistance to stresses, even violent.
- Boiling point 305°C.
- It can be mixed with all similar fluids.

Code	Desc.	Content
4110015295	2895	250 ml
4110014675	2747	1 Lt

## ADDITIVES FOR AUTOMOTIVE MECCANOCAR

**For the professional, the enthusiast, for those who keep to their vehicle**

- Meccanocar in this catalog brings together the best of additives for the maintenance, repair and care of the means of transport of any kind. A selection of products created with cutting-edge technologies to keep their young middle, so you always get maximum performance with minimum consumption, to cure the infirmities of age and any problems that may arise in normal use, to restore the original operating conditions, to repair the breaks without expensive disassembly and replacement of parts.
- This catalog is intended as a valuable guide for the seller, the professional, the enthusiast looking for the right solution to their demands, their questions. A guide containing tips and helps everyone to understand that the right product, the right additive, not an unnecessary expense, but an investment to avoid faults, breakdowns, malfunctions, pollution, to avoid future expenses and costs of repairs that may be replaced by the right treatment. Taking care of your vehicle helps themselves, helps the environment, it helps to prolong the life of the media and to make their use more pleasant.
- Each item is accompanied by a thorough explanation, simple and affordable for everyone. On demand professionals can receive technical data sheets and safety for the correct use.

## Treatment for petrol engines



- Complete treatment for petrol systems, of any type, carburettors and injection systems, for cleaning the whole system from the tank to the combustion chamber, lubricating all of moving parts, and preserving performance and reliability of vehicles over time.
- It prevents and eliminates the condensation, dissolves impurities, rust, paraffin alcohol deposits, lacquers and sludge. It keeps clean and lubricates the carburettor pumps, the injector nozzles and all inner parts of carburettors. It avoids fuel ageing during long periods of storage.
- The dual function of cleaner and lubricant acts up to the inside of the combustion chamber by keeping the valves clean, removing the deposits that have been forming over time, frees the piston rings, restores functioning of the supply systems and the compression resistance.
- It does not damage seals, pipes, moving parts, catalytic converters, oxygen sensors, any electronic sensors in any way. It contains no kerosene and is compliant with standards UNI EN 228.
- It is used by mixing 300 ml of product with minimum 15 litres of fuel up to max. 60 litres. It restores, during operation, the engine power, reduces consumption and noxious emissions, makes ignition easier, eliminates irregular idle speed, engine knocking, malfunctioning, serrations. It makes driving more enjoyable and brilliant.
- The use is advisable when servicing the car or when necessary owing to malfunctioning.

Code	Desc.	Content ml
4110020450	6362	300 ml



## Cleaner LPG



Code	Desc.	Content ml
4110019820	6270	120

- **WHAT IT IS**
- It 'a descaling detergent for maintenance and deep cleaning, if necessary, of the entire system of gas injection LPG plants is of an old design in both new models gaseous injection. It allows to maintain efficient and perfectly clean the tank, the piping, the solenoid valves, the pressure reducer and injectors. The descaling joined a lubricant Unlocking and lubricates mechanisms, removes all dirt and impurities present in the gas, protects the intake valves from wear may occur since it from LPG.
- **ON WHAT MEANS**
- Cleaner for LPG is used on all vehicles equipped with gas system is injection liquid is injected gaseous distinction. It is recommended for use with our Engine Cleaner Petrol, cod. 411 00 20450-6362 for perfect cleaning of the whole plant of suction and injection of the engines.
- **HOW TO USE**
- Wait for the LPG tank is near empty. Screw the filling valve adapter with the correct thread, attach the other end of the cylinder additive and keeping it upside down press strongly for 35-40 seconds, so that the product enters into the tank.
- Proceed to the normal supply of LPG and resume normal use of the car.
- Treatment is recommended for each service, or whenever the opportunity presents with irregular operation or power loss.

## Treatment for diesel engines



Code	Desc.	Content ml
4110020460	6363	300 ml

- Complete treatment for diesel systems, of any type, both injection systems with pre-chamber and direct injection ones (common rail - Injectors-pump) for cleaning the whole system, from the tank to the combustion chamber, lubricating all of moving parts, and preserving performance and reliability of vehicles over time.
- It prevents and eliminates the condensation, dissolves impurities, rust, deposits of seaweeds and paraffin, lacquers and sludge. It keeps clean and lubricates the high/low-pressure carburettor pumps, pipes, and injector nozzles. It avoids ageing of fuel during long periods of storage.
- The dual function of cleaner and lubricant acts up to the inside of the combustion chamber by keeping the valves clean, removing the deposits that have been forming over time, frees the piston rings, restores functioning of the supply systems and the compression resistance.
- It does not damage seals, pipes, moving parts, catalytic converters, diesel particulate filters (DPF), oxygen sensors, any electronic sensors in any way. It contains no kerosene and is compliant with standards UNI EN 590.
- It is used by mixing 300 ml of product with minimum 15 litres of fuel up to max. 60 litres. It can be used to fill new filters for circuits triggering. It restores, during operation, the engine power, reduces consumption, noxious emissions, and black smoke, makes ignition easier, eliminates irregular idle speed, engine knocking, malfunctioning, excessive vibrations. It makes driving more enjoyable and brilliant.
- The use is advisable when servicing the car or when necessary owing to malfunctioning.

## Treatment for diesel engines “Truck”



- Complete treatment for diesel systems, of any type, both injection systems with pre-chamber and direct injection ones (common rail - Injectors-pump), for cleaning the whole system, from the tank to the combustion chamber, lubricating all of moving parts, and preserving performance and reliability of vehicles over time.
- The special formulation allows to remove large amount of water in the tanks, by preventing the dangerous formation of seaweeds and deposits at the same time, thus avoiding any damage and clogging.
- It prevents and eliminates the condensation, dissolves impurities, rust, deposits of seaweeds and paraffin, lacquers and sludge. It keeps clean and lubricates the high/low-pressure carburettor pumps, pipes, and injector nozzles. It avoids ageing of fuel during long periods of storage.
- The dual function of cleaner and lubricant acts up to the inside of the combustion chamber by keeping the valves clean, removing the deposits that have been forming over time, frees the piston rings, restores functioning of the supply systems and the compression resistance.
- It does not damage seals, pipes, moving parts, catalytic converters, diesel particulate filters (DPF), oxygen sensors, any electronic sensors in any way. It contains no kerosene and is compliant with standards UNI EN 590.
- It restores, during operation, the engine power, reduces consumption, noxious emissions, and black smoke, makes ignition easier, eliminates irregular idle speed, engine knocking, malfunctioning, excessive vibrations. It makes driving more enjoyable and brilliant.
- The use is advisable when servicing the car or when necessary owing to malfunctioning.
- **RECOMMENDED DILUTIONS:**
- **Energetic action and first treatment:** 1 litre of product per 400 litres of fuel.
- **At every scheduled service:** 1 litre of product per 650 litres of fuel.
- **Continuous use and for maintaining:** 1 litre of product per 2000 litres of fuel.

Code	Desc.	Content
4110020470	6364	1 L.
4110020480	6365	20 L.

## Injector cleaning machine



- Special equipment designed for direct and intensive cleaning of the petrol or diesel injection systems of any type. It allows descaling, unlocking, and restoring of the optimal operation of the supply systems without removal from engines.
- It allows engine operation without the vehicle supply (tank and pumps) thus providing pure product for a deep cleaning of the injection systems. It is used with the apposite cleaners for petrol or diesel and does not damage the anti-pollution systems, as catalytic converters and DPF filters.
- The 12 Volts operation allows its use everywhere, the application is easy and quick, the optimal values of engine operation are restored immediately. The inner fuel pump allows use also for decanting fuels or emptying tanks.
- The intensive treatment with the apposite products restores the engine power, reduces consumption, noxious emissions, and black smoke, makes ignition easier, eliminates irregular idle speed, engine knocking, malfunctioning, excessive vibrations. It makes driving more enjoyable and brilliant.

Code	Desc.
4770007180	782

## Treatment for petrol injectors



- Intensive treatment intended for our Injection cleaning machine, to be used pure for intensive cleaning and descaling of the petrol injection systems.
- By following the instructions supplied with the machinery, the pure product reaches the inside of the engine combustion chamber and cleans, lubricates and restores the perfect operation of: injectors, intake and exhaust valves, piston rings, inlet and exhaust valves.
- It restores the correct fuel jets, eliminates dripping of injectors, adjusts the correct amounts of air/fuel, reset the right compression levels. The treatment is performed with the engine at temperature and changing the revolutions, so as to simulate driving on the road as much as possible.
- It restores the engine power, reduces consumption and noxious emissions, makes ignition easier, eliminates irregular idle speed, engine knocking, malfunctioning, serrations. It makes driving more enjoyable and brilliant.
- It does not damage seals, pipes, moving parts, catalytic converters, oxygen sensors, any electronic sensors in any way. It contains no kerosene and is compliant with standards UNI EN 228.
- The treatment is recommended every 50,000-60,000 Km or when problems due to supply occur.

Code	Desc.	Content
4110020490	6366	5 L.

## Treatment for diesel injectors



- Intensive treatment intended for our Injection cleaning machine, to be used pure for intensive cleaning and descaling of the diesel injection systems.
- By following the instructions supplied with the machinery, the pure product reaches the inside of the engine combustion chamber and cleans, lubricates and restores the perfect operation of: high-pressure pump, injectors, intake and exhaust valves, piston rings, inlet and exhaust valves, EGR valves.
- It restores the correct fuel jets, eliminates dripping of injectors, adjusts the correct amounts of air/fuel, reset the right compression levels. The treatment is performed with the engine at temperature and changing the revolutions, so as to simulate driving on the road as much as possible.
- It restores the engine power, reduces consumption and noxious emissions, excessive smoke at the exhaust, makes ignition easier, eliminates irregular idle speed, engine knocking, malfunctioning, serrations, and too many vibrations. It makes driving more enjoyable and brilliant.
- It does not damage seals, pipes, moving parts, catalytic converters, oxygen sensors, any electronic sensors in any way. It contains no kerosene and is compliant with standards UNI EN 590.
- The treatment is recommended every 50,000-60,000 Km or when problems due to supply occur.

Code	Desc.	Content
4110020540	6370	10 L.



## Liquid for washing for FAP/DPF



- Specific liquid for cleaning the clogged filters FAP/DPF without disassembly of the vehicle. It can be used with the apposite pneumatic dispensers, as our code 4110001210-2005.
- It removes any kind of clogging due to soot and particulate inside filters in an easy and quick manner and does not damage the supports and the internal side of the exhaust system. Furthermore, it is not necessary to disassemble any part of the exhaust system of the engine.
- Very easy to use, it is enough to load the apposite dispenser with 750 ml of pure product ad spray it into the FAP/DPF through the holes of the pressure sensors situated on the rear side, towards the filter body, making sure it is completely wet.
- After 30-40 minutes, rinse with the same modality, using the apposite liquid code 4110020420-6360. By switching the vehicle engine on, some foam will come out from the exhaust system, thus removing all broken up dirt and cleaning the filter.
- After the procedure, reset all lights on the dashboard.

Code	Desc.	Content	Color
4110020410	6359	5 L	RED

## Rinsing liquid for FAP/DPF



- Specific liquid for rinsing the filters FAP/PDF after washing with out code 411002041-6359. It permits the removal of the washing liquid and all broken up dirt in the filters without disassembling the vehicle.
- It is used following the instructions and spaying 750 ml of pure product into the FAP/DPF with the apposite dispenser code 4110001210-2005.
- It removes any kind of clogging due to soot and particulate inside filters in an easy and quick manner and does not damage the supports and the internal side of the exhaust system. Furthermore, it is not necessary to disassemble any part of the exhaust system of the engine.

Code	Desc.	Content	Color
4110020420	6360	5 L	LIGHT BLUE

## Pneumatic dispenser for washing liquid FAP/DPF



- Special dispenser equipped with double probe, rigid and flexible, for applying the washing/rinsing liquids into the filter FAP/DPF.
- Pneumatic operation, easy to charge and to use. Max. capacity of 750 ml.
- Completely made in metal with strong, extremely long-lasting seals. Dual taps for opening of compressed air passage and for spraying the products inside.

Code	Desc.	Content
4110001210	2005	750 ml



## Gasoline additive



Code	Desc.	Content ml
4110014905	2793	250

- **WHAT IT IS**
- The additive for gasoline Meccanocar is used at regular intervals before pouring it into the tank to fill. It is a cleaner and lubricant that keeps clean the tank, the fuel pump, the pipes, intake manifolds and systems to carburetor or injection, avoiding the formation of dirt, condensation, carbon deposits also on the valves and in the combustion chambers .
- **ON WHAT MEANS**
- It can be used in every vehicle with a petrol engine: cars, bikes, scooters, boats two times. Particularly suitable for old cars or vintage for the use of unleaded petrol, to compensate for the lack of lubricity of the lead. Great for keeping the efficiency of cars with LPG or CNG. On modern cars it allows keeping clean the whole power supply system, the valves and the combustion chambers, avoids the gluing of the piston rings, lubricates the modern high pressure pumps and prevents the breakage and noise. It reduces exhaust emissions. It is compatible with catalytic converters and oxygen sensors.
- **HOW TO USE**
- Add a bottle of 250 ml per tank of fuel at intervals of 2,000 km. One vial of product is sufficient for the treatment of 70-80 liters of gasoline.

## Cleaner fuel injectors



Code	Desc.	Content ml
4110016250	3935	250

- **WHAT IT IS**
- The additive cleaner for petrol injectors Meccanocar is a descaling able to perform a cleaning of all types of dirt of the whole power supply system, when introduced in the tank along with the fuel. Can also be used for intensive cleaning of the injectors and the intake valves by using it diluted with gasoline in proportions 1: 1 with the appropriate machines type "drip" or similar.
- The product dissolves and allows the removal of incrustations, sediment, dirt accumulated in the tanks, the piping, in fuel pumps, fuel injectors, the intake valves, in the combustion chambers and on the exhaust valves. Restore condition, unlocks the piston rings, improves the tightness of the valves, gives the power to the original values and reducing consumption.
- **ON WHAT MEANS**
- It can be used in every vehicle with a petrol engine: cars, bikes, scooters, boats two times. Great for keeping the efficiency of cars with LPG gas in union with the additive gas for our item cod. 411 00 19820-6270. On all means it allows to keep clean the whole power supply system, the tank, the valves and the combustion chambers, unlock the piston rings, cleans the modern high pressure pumps and prevents the breakage and noise. It reduces exhaust emissions. It is compatible with catalytic converters and oxygen sensors.
- **HOW TO USE**
- Add a bottle of 250 ml per tank of fuel at intervals of 2,000 km. One vial of product is sufficient for the treatment of 40-60 liters of gasoline, a higher concentration does not damage the treated parts. When used with machines like "drip" or similar dilute the product 1: 1 in petrol and enter it into the machine.

## G / R-Plus Cleaner throttle bodies



- **WHAT IT IS**
- The G / R Plus Meccanocar is a descaling spray cleaner for deep cleaning of the butterfly valves present on petrol engines. Normal use of the car leads to a contamination of these valves controlled from the accelerator, resulting in erratic, unstable idle, sluggishness of the engine, starting problems. Spraying this product on the valve, with the engine off or running, you get the perfect cleaning, the dirt is dissolved, it sucked up and burned by the engine trouble, the throttle will resume normal operation, minimal regular returns, the engine resumes liveliness. No need to remove the valve from operation for perfect cleaning.
- **ON WHAT MEANS**
- It can be used in every vehicle with a petrol engine: cars, bikes, scooters, boats two times. The product is also effective for the cleaning of bodies and shutters of the carburetors. Restore the smooth operation due to incrustations that form in normal use.
- **HOW TO USE**
- With hot engine and at the temperature of use, off, disconnect the tube that carries the air from the filter to the throttle valve.
- Shake can well, engage the extension on the button and dispense the product on the encrusted parts until clean. The bottle dispenses the product in each position. Replace the hose, start the engine and travel for a few minutes to burn the extracted product.
- With the engine running spraying at short intervals so that the engine stops, or keep the high idle spraying the product until clean. Replace the air sleeve and take a short drive to burn the extracted product.

Code	Desc.	Content ml
4110016120	3870	400

## Diesel fuel additive



- **WHAT IT IS**
- The additive for diesel Meccanocar is used at regular intervals before pouring it into the tank to fill. It is a cleaner and lubricant that keeps clean the reservoir, the pumps of diesel oil, the pipes, intake manifolds and injection system, thus avoiding the formation of dirt, condensation, carbon deposits also on the valves and in the combustion chambers .
- **ON WHAT MEANS**
- Safe to use on all vehicles with a diesel engine: cars, commercial vehicles, trucks, boats, agricultural vehicles, etc., Both engines of old design is of modern engines with direct injection. Absolutely it does not damage the catalysts mounted exhaust systems and filters FAP / DPF. It keeps clean the entire fuel system, valves and combustion chambers, avoids piston ring sticking, lubricates modern high pressure pumps and prevents breakage and noise. It reduces exhaust emissions.
- **HOW TO USE**
- Add product to fuel at intervals of 2,000 km. 250 ml of the product are sufficient for the treatment of 30- 50 liters of diesel. For larger quantities of fuel to add multiples of 250 ml accordingly.

Code	Desc.	Content
4110014900	2792	250 ml
4110017730	4495	5 L.

## Cleaner diesel injectors



- **WHAT IT IS**
- The additive for diesel injectors cleaner Meccanocar is a descaling able to perform a cleaning of all types of dirt of the whole power supply system, when introduced in the tank along with the fuel. It can also be used for intensive cleaning of the injectors and the intake valves by using it diluted with diesel oil in proportions 1: 1 with the appropriate machines type "drip" or similar.
- The product dissolves and allows the removal of incrustations, sediment, dirt accumulated in the tanks, the piping, in fuel pumps, fuel injectors, the intake valves, in the combustion chambers and on the exhaust valves. Restore condition, unlocks the piston rings, improves the tightness of the valves, gives the power to the original values and reducing consumption.
- **ON WHAT MEANS**
- It can be used on any vehicle with a diesel engine: cars, commercial vehicles, trucks, boats, agricultural vehicles, etc., Both engines of old design is of modern engines with direct injection. On all means it allows to keep clean the whole power supply system, the tank valves and combustion chambers, unlock the piston rings, cleans the modern high pressure pumps and prevents the breakage and noise. It reduces exhaust emissions. Absolutely not harm the catalysts and filters FAP / DPF mounted exhaust systems.
- **HOW TO USE**
- Add product to fuel at intervals of 2,000 km. 250 ml of the product are sufficient for the treatment of 40- 60 liters of diesel. For larger quantities of fuel to add multiples of 250 ml accordingly. A higher concentration does not damage the treated parts. When used with machines like "drip" or similar dilute the product 1: 1 in diesel fuel and enter it into the machine.

Code	Desc.	Content
4110016260	3940	250 ml
4110019760	6240	5 L.

## Diesel Lube - Multifunction for diesel engines



- **WHAT IT IS**
- Diesel Lube Meccanocar is a multifunctional additive designed for the proper maintenance of modern diesel engines with direct injection common rail or pump injector. Added to the fuel helps to disperse moisture and dirt from fuel, oil all components of the fuel from the pump to the injectors, prevents the accumulation of dirt in the pipes, increases the cetane number of diesel and therefore increases the performance of vehicles, driving becomes more fluid and enjoyable. Engine life and his health lengthen considerably avoiding breakdown.
- **ON WHAT MEANS**
- Particularly suitable for all modern direct injection engines, it can also be used on engines of older conception maintaining the protective properties and detergents also for these. It can be used on all the equipment powered by diesel: cars, commercial vehicles, trucks, boats, agricultural vehicles, etc..
- **HOW TO USE**
- Add product to fuel at intervals of 2,000 km. 250 ml of the product are sufficient for the treatment of 60- 80 liters of diesel. For larger quantities of fuel to add multiples of 250 ml accordingly. A higher concentration does not damage the treated parts.

Code	Desc.	Content ml
4110015355	2965	250



## Additive for diesel antismoking



- **WHAT IT IS**
- The additive for diesel antismoking Meccanocar is recommended to remove the exhaust smoke and particulate emissions and soot in diesel powered engines of all kinds, direct injection or indirect, manning or not with particulate filters and catalysts. It also eliminates much of the bad smell of exhaust, lubricates the fuel system and keeps clean injectors and pumps.
- **ON WHAT MEANS**
- It can be used on any vehicle with a diesel engine: cars, commercial vehicles, trucks, boats, agricultural vehicles, etc., Both engines of old design is of modern engines with direct injection.
- **HOW TO USE**
- Add product to fuel at intervals of approximately 2000 km or as necessary. 250 ml of the product are sufficient for the treatment of 50-70 liters of diesel. For larger quantities of fuel to add multiples of 250 ml accordingly. A higher concentration does not damage the treated parts.

Code	Desc.	Content
4110019770	6245	250 ml
4110019780	6250	5 L.

## Antifreeze additive for diesel



- **WHAT IT IS**
- The antifreeze additive for diesel Meccanocar is necessary to avoid that in the cold season, and at low temperatures, the paraffin contained within the fuel will solidify, clogging the filters and causing machine downtime and costs for restoring the plant. Used in the right amounts lowers the freezing temperature of about 13 ° C, increasing this percentage of additive you will get an increase in quality antifreeze.
- **ON WHAT MEANS**
- It can be used on any vehicle with a diesel engine: cars, commercial vehicles, trucks, boats, agricultural vehicles, etc., Both engines of old design is of modern engines with direct injection. Not damaging catalysts and filters FAP / DPF.
- **HOW TO USE**
- Pour into the tank the right amount of additive before entering the diesel. A quantity of 250 ml is sufficient to treat 50 liters fuel by lowering the freezing temperature of 13 ° C. For extremely cold enter larger amounts of additive.

Code	Desc.	Content
4110019790	6255	250 ml
4110019800	6260	5 L.



## G / R Diesel-suction cleaner diesel and EGR valves



- **WHAT IT IS**
- The G / R Diesel Meccanocar is a descaling detergent spray for the cleaning and removal of dirt and incrustations by the suction system of the diesel engines, including the EGR valve. It cleans and lubricates all of the components of the intake system including the intake valves and exhaust, the combustion chamber, the valves on the discharge. Restore the correct air / fuel decreasing consumption, fuel venting and eliminating irregularities.
- **ON WHAT MEANS**
- It can be used on any vehicle with a diesel engine: cars, commercial vehicles, trucks, boats, agricultural vehicles, etc., Both engines of old design is of modern engines with direct injection. Not damaging catalysts and filters FAP / DPF.
- **HOW TO USE**
- With hot engine and at the temperature of use, remove the tube that carries the air from the filter housing to the intake manifold or the turbocharger. Taking accelerated the engine, spray with spray short and pausing every 5-6 sprays half the bottle directly in the aspiration. Turn off the engine and let it sit for about 15 minutes.
- Turn the engine in the same way the rest of the contents of the spray tank, then hang up the hose and walk a few kilometers before checking the smoke and vehicle emissions.
- For intensive cleaning of the EGR valve remove it from its housing and spray the product directly into the mechanism until clean.

Code	Desc.	Content ml
4110019810	6265	400

## Biocide anti-algae for fuel



- **WHAT IT IS**
- Biocide Anti-algae for Oil is a product designed to prevent the formation of organic dirt and algae in diesel fuel or heating that has been stored and immobile for a long time. Has a preventive and curative in any case in which the diesel oil remains stationary and is not consumed for a long time, eliminates the fermentation phenomena and the emergence and growth of algae inside, resulting in clogging of filters, pipes, pumps, injectors and damage to the motors.
- **ON WHAT MEANS**
- Biocide Anti-algae for Oil is used inside the storage tanks of all sizes, in drums and tanks of the means that are at a standstill for longer stops. It is not necessary to use in cases where the diesel fuel is consumed in a short time or is subjected to continuous movement.
- **HOW TO USE**
- Biocide Anti-algae for Oil should be added to the fuel each time you refuel, 1 liter of additive can treat up to 1000 liters of diesel. For vigorous action in the event of contamination of the tanks already in place to add 1.5 liters of additive per 1000 liters of fuel.
- Do not add a minor amount of additive in the storage tanks or in tanks, the disinfecting effect against microorganisms would not take place, and they would strengthen generating a resistance to the following treatments.

Code	Desc.	Content lt
4110019390	5990	1
4110019395	5995	5

## Cleaner for lubrication systems



Code	Desc.	Content ml
4110015900	3260	500 (2x250)

- **WHAT IT IS**
- It 'a descaler for all the circuits of lubrication of petrol and diesel engines of any size. It allows to remove all dirt, sludge, solid deposits that accumulate during normal operation of the engine or in the case of contamination of the lubricating oil by other fluids such as antifreeze, fluids for servomechanisms, etc.
- The treatment is carried out to change the oil with cleaner frees all oil passages, even the tiny, unlocks the piston rings, perfectly cleans the whole upper part of the engine and collects debris in the sump 'Oil for download together with the oil exhausted.
- **ON WHAT MEANS**
- It can be used on any vehicle with diesel or gasoline engine: cars, motorcycles, commercial vehicles, trucks, boats, agricultural vehicles, etc., On the means of any age. All the media keeps clean all the lubrication system, unlock the piston rings, the free oil passages clogged, reports the original engine efficiency. Using when changing oil and filter, for every service.
- **HOW TO USE**
- At the time of oil change, with the engine hot, and at operating temperature, enter the cleaner inside the motor, directly in the oil to be changed. Restart and let it idle for about 15 minutes. 250 ml treats up to 6 liters of oil. For larger amounts add multiple quantities of the cleaner.
- After the indicated time drain the oil and proceed with the normal oil change and filter.

## Engine oil additive with MOS2



Code	Desc.	Content ml
4110014910	2794	250

- **WHAT IT IS**
- The additive for engine oil Meccanocar allows, thanks to molybdenum disulphide content, to give back to old engines and large performance lost. The raw materials that make up work from friction, improving the flow of moving parts, fill the gaps of worn parts now bringing the values of compression and the games to the original values. It decreases oil consumption and fuel together with the noise and operating temperatures.
- **ON WHAT MEANS**
- It is used in all gasoline and diesel of any means, especially heavy goods vehicles, buses, quarrying, construction equipment, tractors, agricultural machinery, etc..
- **HOW TO USE**
- Shake the box and enter in the engine oil in the amount of 250 ml every 6 liters of oil. For higher volumes enter multiples of the pack. The effect of the additive is felt after traveling a few hundred kilometers, so that the substance is stable on mechanical parts.
- Treatment is recommended at every oil change to keep over time the properties of the product.

## Stop leak for engine



- **WHAT IT IS**
- The Leak Stop for engines Meccanocar eliminates small leaks and leaks that arise due to aging of the gaskets, o-rings, of each type of seal present on the engines of motor vehicles and on hydraulic circuits, also under pressure. Its action restores the rubber seals the elasticity and sealing originating, avoiding disassembly of the motors, servos, exchange rates, differentials, etc..
- And 'suitable and good to remove the oil consumption due to aging of the rubber seal of the valves. Restore perfect seal and prevents the replacement also in engines with many kilometers behind.
- **ON WHAT MEANS**
- The use is indicated on any type of medium such as cars, motorcycles, commercial vehicles, trucks, boats, agricultural vehicles, etc., But also in hydraulic circuits of any type and operating at any pressure. The use of engine stop leak does not affect in any way the functionality of processed fluids, if used in the right amounts.
- **HOW TO USE**
- Enter in the circuit concerned by the loss 60 ml of product per liter of fluid contained. Start the engine and use the means normally for a few hundred kilometers, then check that the leak has stopped.
- The engine stop leak Meccanocar can stay forever in the particular treaty without any contraindications, continuing to perform its function over time.

Code	Desc.	Content ml
4110017580	4420	250

## Descaling liquid for radiators



- **WHAT IT IS**
- Liquid product which, if necessary descaling and cleaning the inside of the liquid cooling circuits of all the motor vehicles. Removes limescale, sludge, algae and oil residues that may be inside the circuit, radiators, inside the pipes, engine blocks, pumps. If contamination by engine oil helps to eliminate it before refilling with new antifreeze.
- Usable on any type of refrigerant circuit, sealed or not. It does not affect the seals, hoses, metal or rubber, the pump impeller, the metal of the engine. Restore the original qualities of the old circuits.
- **ON WHAT MEANS**
- Operation is indicated on any type of medium such as cars, motorcycles, commercial vehicles, trucks, boats, agricultural vehicles, etc..
- **HOW TO USE**
- A hot engine operating temperature and pour the descaling in the coolant. 250 ml of product can treat circuits containing not more than 3 liters of liquid. For larger amounts add multiple packs.
- Let the engine idle for about 10 minutes, then drain the circuit and rinse thoroughly under running water before filling with new antifreeze.

Code	Desc.	Content ml
4110013400	2720	250

## It seals radiator fluid



- **WHAT IT IS**
- Product designed to close small leaks, oil leaks and close small cracks in the cooling circuits of all vehicles. It seals the radiator liquid in the presence of a loss dries creating a real cap on the break, repairing indefinitely leakage and avoiding costly replacement and dismantling of the details cracked.
- Its use does not affect the quality of antifreeze, the functionality of the circuit and of the moving parts. It can stay forever inside the motor without any adverse effects.
- **ON WHAT MEANS**
- Operation is indicated on any type of medium such as cars, motorcycles, commercial vehicles, trucks, boats, agricultural vehicles, etc..
- **HOW TO USE**
- Pour the product directly into the liquid of the cooling circuit. 250 ml of product can treat circuits containing not more than 3 liters of liquid. For larger amounts add multiple packs.
- Normally use the means allowing the product to reach every corner of the cooling circuit and act. After a few hundred kilometers check that the leak is repaired, if not, replace the defective part.

Code	Desc.	Content ml
4110013300	2719	250



## Emulsifiable engine wash liquid



- Detergent for the outer washing of all engines and engine spaces.
- It eliminates any hard dirt like grease, oil, fuel, glues, etc.
- It acts in a few minutes without need of rinsing.
- If used on painted or chromium-plated rubber details it is better to rinse with care to prevent the product from marking the material.
- To be used diluted in water in ratio 1 to 1, in solvents (diesel oil or kerosine) in ratio from 1 to 1 - to 1 to 5 keeping the characteristics of emulsible power.
- For washing dirtier than usual, use the concentrated product.

### WARNINGS

- Some motorcycle manufactures in the instructions book advice the client not to wash the motorcycle with strong solvents and detergents.
- The product cannot be discharged in sewers, but it must be collected in the special tanks.
- The product must be kept in closed containers.

Code	Desc.	Content It
4110005600	2641	5
4110005800	2643	20

## Engine wash spray



- It is a detergent for the outer washing of all engines and engine spaces.
- It eliminates any hard dirt like grease, oil, fuel, glues, etc.
- It acts in a few minutes without need of rinsing.
- Suitable also for the immediate cleaning of small mechanical pieces.

Code	Desc.	Content ml
4110003600	2623	400

## Liquid for washing mechanical pieces in fountain or bath type washing tanks



- Low-flammability point, solvent-based liquid; ideal for cleaning and degreasing mechanical pieces in electrical or pneumatic fountain or bath type washing tanks.
- Ideal for car, motorcycle and industrial vehicle workshops during the disassembly and repair of mechanical parts.
- Quickly and effectively removes all types of dirt, grease, oily deposits from mechanical parts. Does not corrode plastic and rubber; parts treated become like new. has a low odour, is not irritating for the user and is safe thanks to the low flammability. It is used neat, pouring it into the tank of the washing tank and carrying out the tank manufacturer's instructions. Can be utilised in our pneumatic parts washing tank code 470 00 04800-2587.

Code	Desc.	Cont. Lt
4110018520	5075	5
4110018490	5060	25

## Scale-remover for carburetors



- It is a cleaner with a scaleremoving effect. Particularly used to clean carburetors and housing valves, rings, choke valves and elastic segments.
- Its action reduces carbonaceous deposits allowing fuel saving, getting also a better ratio air-fuel, helping for a better setup of the engine.
- If you don't want to dismantle the carburettor, you can spray the product in the air duct (suction muff) dismantling the filter.
- Also very good dissolver of lakes, sludges and paints.

Code	Desc.	Content ml
4110010300	2688	400

## Pulicarb detergent for carburettors



- It is an emulsifiable detergent based on solvents suitable for the washing and cleaning of carburettors, car chassis, engines, machine tools.
- It can also be used as cleaner of surfaces particularly dirty with oils, mineral and vegetal fats like: garages, shops, fuel tanks, tanks, etc.
- It must be used pure, if dirty traces persists, repeat the operation, then wash with water.

Code	Desc.	Content It
4110006100	2646	5

## Descaling for ultrasonic tanks



- Liquido disincrostante alcalino per vasche ad ultrasuoni, indicato per l'eliminazione di sporco generico, incrostazioni, calamina. Utilizzabile anche per la pulizia profonda di pezzi meccanici di qualsiasi genere.
- Il prodotto, utilizzato nelle vasche ad ultrasuoni, permette di eliminare lo sporco anche dagli interstizi più nascosti, disgrega lo sporco più vecchio ed incrostato, riporta a nuovo i pezzi trattati.
- Utilizzabile più volte fino al suo completo esaurimento. Si usa diluito in acqua seguendo le indicazioni riportate sull'etichetta, e può essere usato a basse temperature (20-30°C) o alte (80-90°C). La sua alta diluizione lo rende molto efficace ed economico.

Code	Desc.	Content It
4110019900	6305	1

## Disruptive for calamine



- Made specifically for the disintegration and dissolution of deposits dry and resistant such as calamine, rust, dust lining, etc. **Designed specifically for unlocking the injectors of engine cylinder heads before dismantling.**
- Suitable for all machine shops cars and trucks.
- It penetrates nell'incrostazione wetting everywhere, evaporates very slowly allowing sustained action and effective also on deposits older and compact.
- The disintegrant for calamine does not damage the metal parts and the parts of rubber or plastic, can also be used to loosen stubborn incrustation on the brake calipers, nuts and bolts blocked.
- **HOW TO USE**
- Spray generously sull'incrostazione the product to melt, making sure it is completely wet. If you can completely submerge the part encrusted.
- Leave for 15 minutes and remove the product mechanically fouling with a metal tip. Blow compressed air. If necessary, repeat the operation.

Code	Description	Content ml
4110019940	6316	400

## Descaling cleaner for FAP filters



- Alkaline disinfectant specially designed for the cleaning and disinfection of FAP filters clogged and no longer working. By disassembling the filter from the exhaust system and using the descaler with a hot water heater, the filter can be completely cleaned and repaired even if the interior is completely plugged in by the exhaust residues. Suitable for general or official mechanical workshops, car park maintenance.
- Proper use requires filling of the disassembled and sealed filter with the diluted product in 75% to 90% water (3 parts of the product in 1 part of water, up to 9 parts of the product in 1 part of water). Allow for a time varying from 45 minutes to a few hours depending on the intensity of the encrustations in the filter, and then rinse with hot water under pressure until complete cleaning of the inside of the FAP.
- The disinfectant avoids costly filter replacement and completely restores performance as if they were new.

Code	Desc.	Content Kg
4110019420	6051	5



## Internal washing liquid of automatic transmission



- Specific liquid for deep, safe washing of the automatic transmission groups to be used with the apposite machines for cleaning and the regular oil change.
- The product, used pure, allows to remove all used oil and any kind of sludge, metallic dirt and residues due to normal use in the transmission.
- It allows to solve problems due to dirt accumulation: tears, jamming, gear change at wrong speeds, sliding, loud noise.
- Totally harmless for all of seals and metallic parts used in each kind of automatic transmission.

Code	Desc.	Content
4110020430	6361	1 L

## Detergent for brakes



- The Meccanocar detergent for brakes is purposely conceived to clean brake disks and their calipers, equipped with friction materials devoid of asbestos.
- It is at controlled evaporation, allowing to wash away the interested surfaces, without leaving special marks at completed drying.
- It eliminates traces of friction material, rubber waste and what accumulates in the brake group.
- It has a low index of toxicity.

Code	Desc.	Content lt
4110015910	3265	10
4110020040	6326	60

## Brake cleaner



- For the cleaning of disk brakes, and our clutches.
- It penetrates through any dirt oil residual products, greases it dries quickly.
- No need to dismantle the parts.
- It doesn't eat into the treated parts.
- It leaves no waste.
- New valve with increased jet.

Code	Desc.	Content ml
4110015285	2885	500

## Degreasing-Primer universale



- Degreasing solvent of universal type for the elimination of all types of greasy dirt from metal surfaces. It loosens sludge, tar and grease easily, evaporates quickly and leaves surfaces sparkling clean and free from grease, ready for any subsequent processing.
- Usable in any type of mechanical cleaning and degreasing faster than any metal surface rough or painted. It also meets most of plastics and rubbers used on machinery.
- Usable before all types of painting, galvanic treatment, for deep cleaning after the laying of the stainless steel. In the case of subsequent greasing or lubrication it has gripping action, and allows to lubricants used to adhere more tenaciously increasing the durability.
- Also suitable for cleaning of machine parts, tools, brake parts, clutch, motorcycle chain, workbenches.
- **HOW TO USE**
- Spraying the product directly on the parts to remove grease from a distance of about 20 centimeters, the fan shape of the jet allows to cover a large area. Dry naturally the product or, if necessary, wipe with a cloth or paper for cleaning.

Code	Description	Content ml
4110019950	6317	400

## Autocristal spray



- It is an active foam deterging deeply all the surfaces of glass, chromium-plated, of aluminium and painted surfaces(car and lorry glasse,small mirrors, radiator grids, etc...).
- It leaves no marks, it needs no rinsing and doesn't drip from vertical surfaces.
- It doesn't eat into paints, rubbers and plastics.
- After the supply, wait 20-30 seconds to let the product work,then remove with paper.

Code	Desc.	Content ml
4110020510	6368	400

## Liquid glass cleaner



- Liquid detergent studied to clean and make brilliant any surface in glass, crystal, mirrors, chromium plated parts, plastic, etc.
- It leaves no marks and degreases perfectly, leaving a pleasant clean perfume.

### HOW TO USE IT

- Spray the product on the surface to clean, let it work for some moments, then use a soft cloth till complete drying.

Code	Desc.	Content
4110015560	3090	Vapo500 ml
4110017450	4365	5000 ml

## Disposable Hidro Split wet wipes for car windows



- Practical, disposable wet wipes for hydrophobic treatment of car windows.
- Using an innovative formula, Hidro Split wet wipes create a special protection for car windows, vans and industrial vehicles that permit driving in the rain with limited use of the windscreen wipers. In fact, the hydrophobic treatment permits the drops of rain to easily slide away by utilizing the speed of the vehicle.
- The treatment is very simple and quick; clean the surface of the windscreen and rearview mirrors utilizing degreasing products (alcohol or specific products, such as our Autocristal Spray 41100 01500). Wait for the surface to dry and pass a wet wipe over the surface carefully. Wait 15 minutes and remove any haloes. The treatment is immediately active and reaches maximum effect after about 24 hours. Avoid carrying out this treatment in direct sunlight.
- The product has a considerable effectiveness for approximately six months, ensuring greater road safety when raining; it increases the visibility, reduces consumption of the wipers, facilitates the removal of ice in winter. The disposable packet ensures there is no waste.
- Professional product suitable for retail sales and speed of application. It is easily matched to any promotion, service or product. Supplied in special display packaging suitable for counter display.

Code	Description
4110020240	Meccanocar Hidro Split wet wipes



## Personalised disposable Hidro Split wet wipes



- Hidro Split wet wipes can be purchased in a special personalised packaging with your logo. In fact, each wet wipe is repacked in an elegant sachet with enough space for personalization. Personalized wet wipes can be commercialized, matching the sales to a promotional activity.
- Personalized wet wipes can be commercialized, matching the sales to a promotional activity. They can be associated to a promotional campaign or given away free to the customer after a service, thereby facilitating business and giving added value to the services offered. They also increase the company's profit margin simply and quickly.
- Possibility of personalization even on the counter display packaging. It is not possible to utilize gold or silver colours.
- Use SPV0010003

Code	Description
4110020250	Personalised Hidro Split wet wipes



## Clear View disposable wet wipes for car windows



- Practical disposable wet wipes for the treatment and cleansing of car windows inside the car, vans, industrial vehicles.
- Because of their particular nanotechnology formula, Clear View disposable wet wipes efficiently degrease and cleanse the windows inside the vehicle, e.g., windscreen, side windows, rear window and dashboard.
- Clear View wet wipes carry out deep cleansing that removes opaqueness from glass due to humidity, marks, grease and smoke, thereby considerably increasing the visibility without fastidious light reflections.
- The treatment is very simple and quick; dust the surfaces to be treated and pass over with a wet wipe. The treatment immediately works. Avoid carrying out this treatment in direct sunlight.
- The product is very efficient and can be utilized also to cleanse PC monitor screens, video systems and touch screens.
- Professional product suitable for retail sales and speed of application. It is easily matched to any promotion, service or product. Supplied in special display packaging suitable for counter display.

Code	Description
4110020260	Meccanocar Clear View Wet Wipes



## Personalised disposable Clear View wet wipes



- Clear View wet wipes can be purchased in a special personalised packaging with your logo. In fact, each wet wipe is repacked in an elegant sachet with enough space for personalization.
- Personalized wet wipes can be commercialized, matching the sales to a promotional activity. They can be associated to a promotional campaign or given away free to the customer after a service, thereby facilitating business and giving added value to the services offered. They also increase the company's profit margin simply and quickly.
- Possibility of personalization even on the counter display packaging. It is not possible to utilize gold or silver colours.
- Use SPV0010003

Code	Description
4110020270	Personalised Clear View wet wipes



## Autocrystal winter -50 ° C "anti-rain effect"



- Concentrated antifreeze washer fluid for use in wiper bins of all vehicles.
- Item specified for car and V.I. workshops, car bodies and V. I., autosaloni, concessionarie, autolavaggi, autotrasportatori.
- It provides the chemical wiper effect without resorting to particular treatment operations.
- Used as a normal washer allows, in case of rain, better visibility and better workmanship and more silently the windscreen wiper.
- It allows the water drops to slide off at a speed of about 60 km / h, allowing you to travel under the rain without the use of the windscreen wiper.
- It improves the visibility and safety of driving thanks to the breaking of the water veil even with strong showers.
- It keeps the wiper blades soft and allows an anti-slip and anti-misting effect of the wipers.
- It maintains the dispensing system clean, avoiding the formation of the incrustations.
- Designed to achieve the combined antifreeze / antifreeze effect, it resists without freezing until -50 ° C.
- It diffuses a pleasing fragrance that can be perceived even inside the passenger compartment.
- **ADVANTAGES**
- Improves the visibility of day and night in case of rain.
- Minor use of windscreen wiper brushes.
- Significantly contributes to road safety.
- **MODE OF USE**
- Pour into the pan of the pure glass cleaner or dilute to 50% with water.
- The optimum effect is obtained by using the pure product.

Code	Desc.	Content It
4110019400	6035	1

## Winter Autocrystal liquid



**TABELLA RELATIVA**  
AI COD. 411.1050, 1061, 2890 e 6295

% di prodotto in acqua	Temperatura minima
25	-10°C
33	-16°C
50	-25°C
200	-34°C
Puro	-70°C

ΣΥΜΠΥΚΝΩΜΕΝΟ ΑΝΤΙΨΥΚΤΙΚΟ ΥΓΡΟ ΚΑΘΑΡΙΣΜΟΥ ΤΟΥ ΠΑΡΜΠΡΙΖ ΑΝΤΙΠΑΓΩΤΙΚΗΣ ΠΡΟΣΤΑΣΙΑΣ -200C. ΠΡΟΛΑΜΒΑΝΕΙ ΤΟΝ ΣΧΗΜΑΤΙΣΜΟ ΠΑΓΟΥ ΣΕ ΠΟΛΥ ΧΑΜΗΛΕΣ ΘΕΡΜΟΚΡΑΣΙΕΣ ΔΙΑΤΗΡΩΝΤΑΣ ΤΟ ΣΥΣΤΗΜΑ ΨΕΚΑΣΜΟΥ ΤΩΝ ΥΑΛΟΚΑΘΑΡΙΣΤΗΡΩΝ ΑΠΟΤΕΛΕΣΜΑΤΙΚΟ ΑΚΟΜΑ ΚΑΙ ΣΤΟΝ ΠΑΓΕΤΟ. ΔΙΕΥΚΟΛΥΝΕΙ ΤΗ ΡΟΗ ΤΟΥ ΝΕΡΟΥ. ΔΙΑΤΗΡΕΙ ΕΛΑΣΤΙΚΑ ΤΑ ΜΑΚΤΡΑ ΤΩΝ ΥΑΛΟΚΑΘΑΡΙΣΤΗΡΩΝ. ΣΥΝΤΗΡΕΙ ΤΟ ΣΥΣΤΗΜΑ ΤΩΝ ΨΕΚΑΣΤΗΡΩΝ ΚΑΙ ΑΠΟΤΡΕΠΕΙ ΤΗ ΔΗΜΙΟΥΡΓΙΑ ΚΡΟΥΣΤΑΣ. ΣΥΜΠΛΗΡΩΣΤΕ ΤΟ ΣΤΟ ΔΟΧΕΙΟ ΤΗΣ ΠΛΥΣΤΙΚΗΣ ΣΥΜΦΩΝΑ ΜΕ ΤΟΝ ΠΙΝΑΚΑ ΓΙΑ ΝΑ ΕΧΕΤΕ ΤΗΝ ΕΠΙΘΥΜΗΤΗ ΑΝΤΙΠΑΓΩΤΙΚΗ ΠΡΟΣΤΑΣΙΑ.

Code	Desc.	Protection max	Content	Color
4110000800	1059	-70°C	250 ml	Blue
4110000806	1061	-70°C	1 liter	Blue
4110000815	1065	-20°C	250 ml	Green
4110000013	13	-20°C	200 Lt.	Green
4110015290	2890	-70°C	5 liter	Blue
4110019880	6295	-70°C	20 liter	Blue

## Summer Autocrystal liquid



ΣΥΜΠΥΚΝΩΜΕΝΟ ΑΠΟΡΡΥΠΑΝΤΙΚΟ ΥΓΡΟ ΓΙΑ ΚΑΘΑΡΙΣΜΟ ΤΟΥ ΠΑΡΜΠΡΙΖ ΤΟΥ ΑΥΤΟΚΙΝΗΤΟΥ. ΙΔΙΑΙΤΕΡΑ ΚΑΤΑΛΛΗΛΟ ΓΙΑ ΤΗΝ ΑΝΟΙΞΗ ΚΑΙ ΤΟ ΚΑΛΟΚΑΙΡΙ, ΒΟΗΘΑΕΙ ΣΤΗΝ ΕΥΚΟΛΗ Η ΑΦΑΙΡΕΣΗ ΤΩΝ ΕΝΤΟΜΩΝ ΑΠΟ ΤΟ ΠΑΡΜΠΡΙΖ. ΣΕΒΕΤΑΙ ΤΟ ΧΡΩΜΑ, ΤΑ ΕΠΙΧΡΩΜΙΩΜΕΝΑ ΕΞΑΡΤΗΜΑΤΑ ΤΑ ΛΑΣΤΙΧΑ ΣΤΕΓΑΝΟΠΟΙΗΣΗΣ ΚΑΙ ΤΟΥΣ ΥΑΛΟΚΑΘΑΡΙΣΤΗΡΕΣ. ΔΙΕΥΚΟΛΥΝΕΙ ΤΗ ΡΟΗ ΤΟΥ ΝΕΡΟΥ.

Code	Desc.	Content
4110000805	1060	Flacone 250 ml
4110000807	1062	Flacone 1 L
4110020030	6325	Fusto in plastica 200 L

## -50°C anti-rain effect

CODE:4110019400



ΣΥΜΠΥΚΝΩΜΕΝΟ ΑΝΤΙΨΥΚΤΙΚΟ ΥΓΡΟ ΚΑΘΑΡΙΣΜΟΥ ΤΟΥ ΠΑΡΜΠΡΙΖ ΜΕ ΕΦΕ ΑΠΩΘΗΣΗΣ ΤΗΣ ΒΡΟΧΗΣ ΓΙΑ ΤΑ ΠΑΡΜΠΡΙΖ ΟΛΩΝ ΤΩΝ ΑΥΤΟΚΙΝΗΤΩΝ. ΠΡΟΪΟΝ ΕΙΔΙΚΑ ΓΙΑ ΤΑ ΣΥΝΕΡΓΕΙΑ ΑΥΤΟΚΙΝΗΤΩΝ, ΦΑΝΟΠΟΙΕΙΑ ΑΥΤΟΚΙΝΗΤΩΝ, ΑΝΤΙΠΡΟΣΩΠΕΙΕΣ, ΠΛΥΝΤΗΡΙΑ ΑΥΤΟΚΙΝΗΤΩΝ, ΜΕΤΑΦΟΡΕΙΣ. ΧΑΡΙΖΕΙ ΤΟ ΧΗΜΙΚΟ ΑΠΟΤΕΛΕΣΜΑ ΠΟΥ ΕΠΙΤΥΓΧΑΝΕΤΑΙ ΜΕ ΤΟΥΣ ΥΑΛΟΚΑΘΑΡΙΣΤΗΡΕΣ ΧΩΡΙΣ ΝΑ ΕΦΑΡΜΟΖΟΝΤΑΙ ΕΙΔΙΚΕΣ ΜΕΘΟΔΟΙ ΕΠΕΞΕΡΓΑΣΙΑΣ. ΧΡΗΣΙΜΟΠΟΙΕΙΤΑΙ ΟΠΩΣ ΕΝΑ ΚΟΙΝΟ ΥΓΡΟ ΠΛΥΣΤΙΚΗΣ. ΣΕ ΠΕΡΙΠΤΩΣΗ ΒΡΟΧΗΣ ΟΜΩΣ ΠΑΡΕΧΕΙ ΚΑΛΥΤΕΡΗ ΟΡΑΤΟΤΗΤΑ. ΟΙ ΥΑΛΟΚΑΘΑΡΙΣΤΗΡΕΣ ΛΕΙΤΟΥΡΓΟΥΝ ΠΙΟ ΑΘΟΥΡΒΑ. ΟΙ ΣΤΑΓΟΝΕΣ ΤΗΣ ΒΡΟΧΗΣ ΓΛΙΣΤΡΟΥΝ ΜΕ ΤΑΧΥΤΗΤΑ 60 ΧΛΜ./ΩΡΑ, ΑΚΟΜΑ ΚΑΙ ΟΤΑΝ ΤΑΞΙΔΕΥΕΤΕ ΜΕ ΚΑΤΑΡΡΑΚΤΩΔΗ ΒΡΟΧΗ, ΧΩΡΙΣ ΝΑ ΧΡΗΣΙΜΟΠΟΙΗΣΕΤΕ ΤΟΥΣ ΥΑΛΟΚΑΘΑΡΙΣΤΗΡΕΣ. ΒΕΛΤΙΩΝΕΙ ΤΗΝ ΟΡΑΤΟΤΗΤΑ ΚΑΤΑ ΤΗ ΔΙΑΡΚΕΙΑ ΤΗΣ ΟΔΗΓΗΣΗΣ ΔΙΑΣΠΩΝΤΑΣ ΤΟ ΣΤΡΩΜΑ ΝΕΡΟΥ ΑΚΟΜΑ ΚΑΙ ΜΕ ΔΥΝΑΤΗ ΒΡΟΧΗ. ΔΙΑΤΗΡΕΙ ΕΛΑΣΤΙΚΑ ΤΑ ΜΑΚΤΡΑ ΤΩΝ ΥΑΛΟΚΑΘΑΡΙΣΤΗΡΩΝ. ΣΥΝΤΗΡΕΙ ΤΟ ΣΥΣΤΗΜΑ ΤΩΝ ΨΕΚΑΣΤΗΡΩΝ ΚΑΙ ΑΠΟΤΡΕΠΕΙ ΤΗ ΔΗΜΙΟΥΡΓΙΑ ΚΡΟΥΣΤΑΣ. ΣΧΕΔΙΑΣΤΗΚΕ ΓΙΑ ΝΑ ΣΥΝΔΥΑΖΕΙ ΑΝΤΙΨΥΚΤΙΚΑ / ΑΔΙΑΒΡΟΧΟΠΟΙΗΤΙΚΑ ΑΠΟΤΕΛΕΣΜΑΤΑ, ΚΑΙ ΝΑ ΑΝΤΕΧΕΙ ΣΤΟΝ ΠΑΓΕΤΟ, ΣΕ ΘΕΡΜΟΚΡΑΣΙΕΣ ΜΕΧΡΙ -500C. ΜΕ ΕΥΧΑΡΙΣΤΗ ΟΣΜΗ ΠΟΥ ΓΙΝΕΤΑΙ ΑΝΤΙΛΗΠΤΗ ΚΑΙ ΣΤΟ ΕΣΩΤΕΡΙΚΟ ΤΟΥ ΑΥΤΟΚΙΝΗΤΟΥ. ΠΛΕΟΝΕΚΤΗΜΑΤΑ: ΒΕΛΤΙΩΝΕΙ ΤΗΝ ΟΡΑΤΟΤΗΤΑ ΤΟΣΟ ΤΗΝ ΗΜΕΡΑ ΟΣΟ ΚΑΙ ΤΗ ΝΥΧΤΑ, ΟΤΑΝ ΒΡΕΧΕΙ. ΕΛΑΧΙΣΤΟΠΟΙΕΙΤΑΙ Η ΧΡΗΣΗ ΤΩΝ ΥΑΛΟΚΑΘΑΡΙΣΤΗΡΩΝ. ΣΥΜΒΑΛΛΕΙ ΣΗΜΑΝΤΙΚΑ ΣΤΗΝ ΟΔΙΚΗ ΑΣΦΑΛΕΙΑ. ΣΥΜΠΛΗΡΩΝΕΤΑΙ ΣΤΟ ΔΟΧΕΙΟ ΤΗΣ ΠΛΥΣΤΙΚΗΣ ΣΥΣΚΕΥΗΣ, ΩΣ ΕΧΕΙ Η ΑΡΑΙΩΜΕΝΟ ΣΕ ΑΝΑΛΟΓΙΑ 50% ΜΕ ΝΕΡΟ.

## Autocristal ready for summer



- Special liquid ready for use in the windscreen washer tanks of vehicles. Perfectly cleans the windscreen of all dirt, such as grease, mud and insects without leaving halos.
- The "ready" version of autocristal permits a practical and quick use.
- The low-foam formulation makes for perfect cleaning, a brilliantness of the glass without equal and quick drying without leaving traces.

### USAGE METHOD:

- Pour neat into the windscreen washer tank or dilute in water as required.

Code	Desc.	Cont. Lt
4110017480	4380	5
4110019910	6310	20

## SMACCHIO - stain remover for fabrics



- It is a powerful and concentrated stain remover with degreasing characteristics.
- It easily removes dirt and grease stains, from fabrics of cloth, sky artificial leather and vinyl from padding, side coverings, doors, ceilings and other coverings of any nature.
- It leaves no marks and gives the treated part the original aspect and colours back.

### USE AND APPLICATION:

- Shake well before using, put the product on, let the foam work for about 10-20 seconds, then remove with a cloth.
- Not suitable to clean leather.

Code	Desc.	Content ml
4110001051	1889	400

## 1x8 universal detergent



- It is a deterging emulsion based on organic diluents and mineral distillates.
- It removes any kind of dirt: grease, oil, tar, silicone resins, adhesive, waste of synthetic paints and fresh paints.
- It isn't toxic or corrosive.
- High deterging and hygiene power.
- Pleasantly perfumed.
- It absolutely doesn't damage treated surfaces. It can be used on car bodies, on glass surfaces, on any kind of aluminium and PVC door and window frame sections, to clean tools and working places, etc.

### HOW TO USE IT

- Spray the product from a distance of about 20 cm. On the surface to treat. Wait some minutes to produce its effect, then clean energetically with a soft cloth.

Code	Desc.	Cont. ml
4110008100	2666	400



## Active foam - detergent for car interiors



### ΑΦΡΟΣ ΚΑΘΑΡΙΣΜΟΥ ΕΣΩΤΕΡΙΚΩΝ ΧΩΡΩΝ 500ML

ΚΑΘΑΡΙΣΤΙΚΟ - ΑΠΟΛΥΜΑΝΤΙΚΟ ΙΟΝΙΣΜΕΝΟΥ ΕΝΕΡΓΟΥ ΑΦΡΟΥ ΧΩΡΙΣ ΣΙΛΙΚΟΝΗ ΓΙΑ ΟΛΕΣ ΤΙΣ ΕΠΙΦΑΝΕΙΕΣ ΤΗΣ ΚΑΜΠΙΝΑΣ ΤΩΝ ΑΥΤΟΚΙΝΗΤΩΝ. ΙΔΑΝΙΚΟ ΓΙΑ ΤΟΝ ΚΑΘΑΡΙΣΜΟ ΚΑΙ ΤΟ ΓΥΑΛΙΣΜΑ ΤΟΥ ΤΑΜΠΛΟ - ΤΩΝ ΚΡΥΣΤΑΛΛΩΝ - ΤΩΝ ΚΑΘΡΕΦΤΩΝ - ΤΟΥ ΕΣΩΤΕΡΙΚΟΥ ΤΜΗΜΑΤΟΣ ΤΩΝ ΟΡΟΦΩΝ - ΣΥΝΘΕΤΙΚΟΥ ΔΕΡΜΑΤΟΣ - ΓΕΝΙΚΑ ΤΩΝ ΠΛΑΣΤΙΚΩΝ ΤΜΗΜΑΤΩΝ. ΑΦΑΙΡΕΙ ΚΑΙ ΑΠΟΛΥΜΑΙΝΕΙ ΓΡΗΓΟΡΑ ΚΑΙ ΕΥΚΟΛΑ ΚΑΘΕ ΤΥΠΟ ΒΡΟΜΙΑΣ - ΣΚΟΝΗΣ - ΙΧΝΟΥΣ ΝΙΚΟΤΙΝΗΣ - ΛΙΠΑΡΗΣ ΑΚΑΘΑΡΣΙΑΣ ΚΤΛ.

Code	Desc.	Content ml
4110015310	2910	500



### ΓΕΝΙΚΟ ΚΑΘΑΡΙΣΤΙΚΟ 1X8

- It is a deterging emulsion based on organic diluents and mineral distillates.
- It removes any kind of dirt: grease, oil, tar, silicone resins, adhesive, waste of synthetic paints and fresh paints.
- It isn't toxic or corrosive.
- High deterging and hygiene power.
- Pleasantly perfumed.
- It absolutely doesn't damage treated surfaces. It can be used on car bodies, on glass surfaces, on any kind of aluminium and PVC door and window frame sections, to clean tools and working places, etc.

Code	Desc.	Content ml
4110020190	6341	500

## ΑΝΑΖΩΟΓΟΝΗΤΙΚΟ ΠΛΑΣΤΙΚΩΝ 500ML



ΓΥΑΛΙΣΤΙΚΟ, ΠΡΟΣΤΑΤΕΥΤΙΚΟ ΚΑΙ ΑΝΑΖΩΟΓΟΝΗΤΙΚΟ ΠΡΟΪΟΝ, ΓΙΑ ΟΛΑ ΤΑ ΕΞΩΤΕΡΙΚΑ ΠΛΑΣΤΙΚΑ ΜΕΡΗ ΤΩΝ ΟΧΗΜΑΤΩΝ. ΤΟ ΠΡΟΪΟΝ ΑΥΤΟ ΧΑΡΙΖΕΙ ΞΑΝΑ ΤΗΝ ΟΨΗ ΚΑΙΝΟΥΡΓΙΟΥ ΣΤΑ ΕΛΑΣΤΙΚΑ, ΤΟΥΣ ΠΡΟΦΥΛΑΚΤΗΡΕΣ, ΤΙΣ ΑΕΡΟΤΟΜΕΣ ΚΑΙ ΟΛΕΣ ΤΙΣ ΑΒΑΦΕΣ ΕΠΙΦΑΝΕΙΕΣ ΑΠΟ ΠΛΑΣΤΙΚΟ ΠΟΥ ΕΧΟΥΝ ΑΠΟΧΡΩΜΑΤΙΣΤΕΙ ΛΟΓΩ ΤΩΝ ΚΑΙΡΙΚΩΝ ΣΥΝΘΗΚΩΝ ΚΑΙ ΤΩΝ ΑΤΜΟΣΦΑΙΡΙΚΩΝ ΕΠΙΔΡΑΣΕΩΝ. Η ΑΝΑΖΩΟΓΟΝΗΤΙΚΗ ΤΟΥ ΣΥΝΘΕΣΗ ΕΙΣΧΩΡΕΙ ΣΕ ΒΑΘΟΣ ΣΤΟΥΣ ΠΟΡΟΥΣ ΤΟΥ ΥΛΙΚΟΥ ΚΑΙ ΤΟΥΣ ΓΕΜΙΖΕΙ ΓΙΑ ΜΕΓΑΛΟ ΧΡΟΝΙΚΟ ΔΙΑΣΤΗΜΑ, ΕΠΙΤΡΕΠΟΝΤΑΣ ΣΤΟ ΥΛΙΚΟ ΝΑ ΑΝΤΙΣΤΕΚΕΤΑΙ ΣΤΟ ΧΡΟΝΟ, ΚΑΙ ΤΟ ΠΡΟΣΤΑΤΕΥΕΙ ΑΠΟ ΤΗ ΒΡΟΧΗ, ΤΟΝ ΗΛΙΟ ΚΑΙ ΤΗ ΒΡΟΜΙΑ. ΠΡΟΣΚΟΛΛΑΤΑΙ ΣΤΙΣ ΕΠΙΦΑΝΕΙΕΣ ΣΧΗΜΑΤΙΖΟΝΤΑΣ ΕΝΑ ΠΡΟΣΤΑΤΕΥΤΙΚΟ ΦΙΛΜ. ΕΝΔΕΙΚΝΥΤΑΙ ΚΑΙ ΓΙΑ ΤΙΣ ΑΝΩΜΑΛΕΣ ΕΠΙΦΑΝΕΙΕΣ ΜΟΤΟΣΙΚΛΕΤΩΝ, ΣΚΟΥΤΕΡ ΚΑΙ ΣΚΑΦΩΝ.

Code	Desc.	Content ml
4110015540	3080	500

## Universal polishing renovator



ΣΙΛΙΚΟΝΟΥΧΟ ΓΥΑΛΙΣΤΙΚΟ ΣΠΡΕΙ ΓΙΑ ΑΜΑΞΩΜΑΤΑ. ΚΑΘΑΡΙΖΕΙ, ΛΙΠΑΙΝΕΙ ΚΑΙ ΠΡΟΣΤΑΤΕΥΕΙ ΟΛΕΣ ΤΙΣ ΜΕΤΑΛΛΙΚΕΣ ΕΠΙΦΑΝΕΙΕΣ, ΠΛΑΣΤΙΚΟ, ΕΛΑΣΤΙΚΟ, ΒΑΜΜΕΝΟ ΞΥΛΟ, ΔΕΡΜΑ ΚΑΙ ΣΥΝΘΕΤΙΚΟ ΔΕΡΜΑ, ΚΑΛΥΠΤΟΝΤΑΣ ΓΡΑΤΣΟΥΝΙΕΣ ΚΑΙ ΣΗΜΑΔΙΑ. ΜΠΟΡΕΙ ΝΑ ΧΡΗΣΙΜΟΠΟΙΗΘΕΙ ΣΕ ΕΞΩΤΕΡΙΚΑ ΚΑΙ ΕΣΩΤΕΡΙΚΑ ΜΕΡΗ. ΚΑΤΑΛΛΗΛΟ ΚΑΙ ΓΙΑ ΝΑ ΠΡΟΣΔΙΔΕΙ ΕΛΑΣΤΙΚΟΤΗΤΑ ΣΤΙΣ ΤΣΙΜΟΥΧΕΣ. ΑΔΙΑΒΡΟΧΟ ΚΑΙ ΗΛΕΚΤΡΙΚΑ ΜΟΝΩΤΙΚΟ. Η ΣΥΣΤΑΣΗ ΜΕ ΣΙΛΙΚΟΝΗ ΕΠΙΤΡΕΠΕΙ ΑΡΙΣΤΗ ΠΡΟΣΚΟΛΛΗΣΗ ΣΕ ΕΠΙΦΑΝΕΙΕΣ ΚΑΙ Η ΛΕΠΤΗ ΜΥΡΩΔΙΑ ΕΣΠΕΡΙΔΟΕΙΔΩΝ ΕΙΝΑΙ ΕΥΧΑΡΙΣΤΗ ΓΙΑ ΧΡΗΣΗ ΣΕ ΕΣΩΤΕΡΙΚΟΥΣ ΧΩΡΟΥΣ. ΚΑΤΑΛΛΗΛΟ ΓΙΑ ΣΥΝΕΡΓΕΙΑ ΑΜΑΞΩΜΑΤΩΝ ΑΥΤΟΚΙΝΗΤΩΝ ΚΑΙ ΜΟΤΟΣΙΚΛΕΤΩΝ, ΕΚΘΕΣΕΙΣ ΑΥΤΟΚΙΝΗΤΩΝ, ΑΝΤΙΠΡΟΣΩΠΕΙΕΣ, ΠΛΥΝΤΗΡΙΑ ΑΥΤΟΚΙΝΗΤΩΝ, ΦΟΡΤΗΓΑ, ΣΚΑΦΗ ΑΝΑΨΥΧΗΣ. ΨΕΚΑΣΤΕ ΤΟ ΠΡΟΪΟΝ ΣΕ ΑΠΟΣΤΑΣΗ 20 CM ΑΠΟ ΤΗΝ ΕΠΙΦΑΝΕΙΑ ΚΑΙ ΑΠΛΩΣΤΕ ΜΕ ΚΑΘΑΡΟ ΠΑΝΙ. ΜΗΝ ΤΟ ΧΡΗΣΙΜΟΠΟΙΕΙΤΕ ΣΕ ΤΙΜΟΝΙ, ΠΕΝΤΑΛ Η ΠΑΤΑΚΙΑ ΔΑΠΕΔΟΥ.

Code	Desc.	Content ml
4110017610	4435	500

## ΓΥΑΛΙΣΤΙΚΟ ΕΛΑΣΤΙΚΩΝ 500ML



~ ΠΡΟΣΤΑΤΕΥΕΙ ΚΑΙ ΓΥΑΛΙΖΕΙ ΤΑ ΕΛΑΣΤΙΚΑ ΜΕΡΗ ΧΑΡΙΖΟΝΤΑΣ ΚΑΙΝΟΥΡΓΙΑ ΟΨΗ ΣΕ ΟΛΑ ΤΑ ΕΛΑΣΤΙΚΑ ΜΕΡΗ ΤΟΥ ΑΥΤΟΚΙΝΗΤΟΥ. ΣΧΗΜΑΤΙΖΕΙ ΜΙΑ ΔΙΑΦΑΝΗ ΜΕΜΒΡΑΝΗ ΠΟΥ ΠΡΟΣΚΟΛΛΑΤΑΙ ΣΤΟ ΕΛΑΣΤΙΚΟ ΠΡΟΣΤΑΤΕΥΟΝΤΑΣ ΤΟ ΑΠΟ ΤΟ ΚΡΥΟ ΚΑΙ ΑΠΟ ΤΙΣ ΚΑΙΡΙΚΕΣ ΣΥΝΘΗΚΕΣ ΠΑΡΕΧΟΝΤΑΣ ΕΠΙΠΛΕΟΝ ΜΙΑ ΛΑΜΠΕΡΗ ΟΨΗ ΕΞΑΛΕΙΦΟΝΤΑΣ ΤΟΥΣ ΛΕΚΕΔΕΣ ΚΑΙ ΤΟΝ ΑΠΟΧΡΩΜΑΤΙΣΜΟ. ΔΕΝ ΛΕΚΙΑΖΕΙ ΤΙΣ ΖΑΝΤΕΣ ΚΑΙ ΤΑ ΚΑΛΥΜΜΑΤΑ ΤΡΟΧΩΝ.

Code	Desc.	Cont. ml
4110015260	4425	500

## Dashboard cleaner with silicone



- Protective spray polish with silicone for use in the clean, saloni, preparatory drive, drivers, private bus companies, dealerships.
- Product for cleaning car interiors, industrial vehicles, coaches, especially on surfaces of plastic, rubber, leather and artificial leather, wood and composite fibers.
- It gives the treated parts a shiny satin penetrating into gaps and eliminating squeaks due to dust deposits.
- The presence of silicon allows widespread protection of rubber seals and plastic parts from wear, heat and frost.
- Cleans and polishes without leaving parts brilliant effect viscosity and without dirtying crystals and transparent plastics.
- Pleasant citrus scent.
- Spray at about 15 cm away from the treated area and spread with a clean cloth.
- We recommend our cloth Magic Clean (art: 4460004710 - 3982/1).

Code	Desc.	Cont. ml
4110017600	4430	400

## Air spray



- It is a portable clean gas generator. It has two functions:
- **1. BLOW USE**
- It has a small tube allowing access and so the blow also in the most difficult points.
- It eliminates dust and the impurities from holes, on electric components, injectors, breadboards, etc.
- The gas inside causes neither oxidation or corrosion process.
- **2. COOLING USE**
- Turn the canister upside down.
- To cool the electric components like transistors, resistors, injectors, carburetors (system checks at cold working).
- It allows the assembling of metal parts like bearings, ferrules, brasses and shafts also in narrow housings.
- It cools till -53°C.
- **ATTENTION:** the gas jet is inflammable.

Code	Desc.	Cont. ml
4110002400	2610	400

## NO FROST spray defroster



- Aerosol product immediately melting the scaling of hoarfrost and ice from glasses, gaskets, locks, electric aerials, etc.
- It can be used to prevent the forming of scaling.
- Used inside on glasses it prevents their clouding.

### HOW TO USE IT

- Shake the canister well before using. Spray from a distance of about 20 cm. on the surfaces to treat. After a few seconds you can let the windscreen wipers slide for the cleaning of the glass.

Code	Desc.	Cont. ml
4110001040	1872	400

## Washing shampoo



- Product suitable to wash the bodies of vehicles manually or automatically.
- Tested on all kinds of car bodies and paints.
- Suitable also for chromium-plated or plastic parts.
- Good production of foam, it resists and cancel the calcareous-water effect.
- It leaves neither marks nor stains.
- It gives car bodies a very good shining effect.
- Removable with simple rinsing.
- Biodegradable over 90%.
- Use in concentrations from 2% to 3%.

Code	Desc.	Cont. Lt
4110006500	2650	5
4110006700	2652	20

## Pre-washing shampoo



- Product suitable to wash vehicles, before they enter the brush tunnel car-wash.
- Highly concentrated product, specific for high or low pressure washing.
- It eliminates by degreasing action traces of lubricants, greases, sludges, insects.
- It doesn't damage chromium-plated parts, gaskets, paints.
- Biodegradable over 90%.

Code	Desc.	Cont. Lt
4110014920	2796	5
4110014930	2798	20

## Universal liquid detergent



- It is a detergent of general use.
- It degreases and cleans any kind of washable surface.
- It easily removes grease, oil, ink, soot, industrial sludges.
- To be used with manual, mechanical, electrical spray, scrubbing brush, sponge.
- It removes the melt dirt with a clean cloth or a water jet.
- It leaves no stains and doesn't eat into glass, paint, plastic, rubber, metals, pottery, etc.
- Biodegradable at 90%.
- Concentration: from 20 gr to 100 gr per litre depending on the dirt to remove and the hardness of water.

Code	Desc.	Cont. Lt
4110014935	2799	5
4110014945	2801	20



## Industrial floor washing liquid



- Highly-concentrated, degreasing alkaline liquid for cleaning all types of hard surfaces. Ideal for profound degreasing and removing oily marks from industrial floors, covered walls, extraction hoods, tarpaulins, etc.
- Indicated for use in all types of mechanical workshops, car repairers, blacksmiths, metal workers, frame manufacturers, etc.
- Particularly effective on dirt deriving from oils and mineral/synthetic greases, emulsified cutting oils, products for cleaning mechanical parts.

### USAGE METHOD:

- Use the product cold, diluting it in water in a ratio of 1% to 5% (from 10 to 50 grams of product in 1 litre of water). Do not use on surfaces that have a temperature of more than 40°C.
- Vapourise or pass the diluted product over the surfaces to be treated with a brush. wait a few seconds and abundantly rinse with water. To speed up the cleaning operation, rinse using water jet pressure equipment.

Code	Desc.	Cont. Lt
4110017440	4360	5

## Cleaner for rims



- It is a concentrated detergent for light alloy and steel wheel rims. Able to remove any kind of dirt like mud, tar, oil, etc.
- Particularly efficacious against dirt due to the wear of brake pads.
- It leaves no traces either of rubber residual products or of other deposited material.
- After the treatment it gives wheel rims their natural brightness back.
- Biodegradable over 90%.
- Available also in 5000ml can and 500ml supplying valve.

Code	Desc.	Content
4110014950	2802	5000 ml
4110015580	3100	500 ml
4110018510	5070	1000 ml

## Insect removing



- Product formulated especially to remove insects and stains caused by them on windscreens, lights, front bonnets, bumpers, etc...
- You just need a single spray to soften and later remove by washing the insects stuck on the vehicle while driving.

### HOW TO USE IT

- Spray on the part to clean, let it work for some minutes, then wash or remove with a soft and clean cloth.
- If necessary repeat the operation.

Code	Desc.	Cont. ml
4110015570	3095	500
4110016130	3875	5000

## Cargo bi-component detergent



- Bi-component detergent, very concentrated, formula presenting in two separate layers that, shaking before use, melt forming an incredibly efficacious cleaner.
- Suitable to deeply clean lorries, tarpaulins, cars, tanks and to eliminate any kind of persistent stain.
- It doesn't absolutely damage paints, plastic materials, rubber, chromium-plating, etc.
- Biodegradable product over 90%.

### USE:

- Shake strongly before use, dilute in water in proportion 1:40, 1:50 (1:70 in summer time), nebulize on the dry surfaces, then rinse with pressure jet.
- It is not necessary to brush.
- In case of overheated surfaces, it is a good rule to cool them before the use.

Code	Desc.	Cont. KG
4110015510	3065	20
4110016410	4015	5

## Monocomponent detergent cargo



- High concentration alkali cleanser for the elimination of particularly difficult fatty dirt such as smog, traffic film and generally dirty travel.
- Suitable for deep and fast cleaning of truck lorries, heavy truck bodies, chassis and motors, earth moving tools, quarrying tools, etc. The product is also effective for cleaning industrial floors and where dirty greases are present. It can also be used in the food industry for HACCP sanitation plans.
- The product is very effective even in the presence of hard water, does not damage the tires and the plastic. It rinses quickly, leaves no residue.
- Avoid contact with aluminum surfaces and its alloys. Use detergent with cold surfaces and shelter from the sun.
- METHOD OF USE:
- Dilution recommended.
- Heavy dirt: 1:30 - 1:40 in water.
- Medium Dirty: 1:40 - 1:50 in water.
- Light dirty: 1:50 - 1: 100 in water.
- Manual use: dilute the product as directed, spray on the surfaces to be cleaned and rinse with a high pressure cleaner.

Code	Desc.	Content Kg
4110019550	6135	25

## Bicomponent nautical cleaner



- Alkaline, two component, highly concentrated and highly degreasing detergent. formulation that is presented in two separate layers, which are agitated before use, combine to form a cleaner of exceptional effectiveness.
- Ideal for cleaning of plastic surfaces such as fiberglass, nylon, silicone and epoxy resins, ABS, EPDM.
- Its particular composition allows it to be very effective also for eliminating fats, gum marks, sludge, soot, smog and algae residues.
- It is designed for general cleaning of boats.
- It is suitable for cleaning both inside and outside plastic and metal materials. biodegradable at 90%.
- METHOD OF USE:
- Shake the can well before use and then dilute with water.
- To clean the keel, the bilge or the engine room: in the case of dirty tires dilute in water 1:20; in the case of normal dirt, dilute in water 1:40.
- To clean the outer parts of the motors: in the case of stubborn dirt, dilute the product in water in 1: 5 ratio; in case of normal dirt, dilute in 1:10 proportion.
- After dilution it is recommended to apply the product on the part to be treated using sponges or nebulizers.
- After application, it is recommended to leave the product for 1 to 3 minutes and then rinse with water jet or with high pressure cleaner.
- If the surfaces are overheated, cool with water before proceeding. Do not use pure.

Code	Desc.	Cont. KG
4110017780	4520	5

## Self-shining cargo detergent



Code	Desc.	Cont. Lt
4110016200	3910	5
4110016420	4020	25

- Shampoo and pre-wash, two in one for manual and automatic washing of all vehicle bodies with selfshining effect.
- It does not create filterings and it does not opacify varnishes, leaving the surface perfectly sparkling clean, without rings, shiny and with long lasting protection from bad weather conditions.
- It does not create filterings and it does not opacify varnishes.
- It melts away and eliminates the deepest dirt, from all washable surfaces of the motor vehicles it does not contain aggressive substances such as soda and acids.
- Excellent for the cabs on heavy motor vehicles, and for deep cleaning of caravans and trailers.
- Easy to dry, not shape filterings on the glasses, sides or plastic surfaces. It is advisable to use the product on cool vehicle bodies, or to cool them off with a jet of water.

### USE:

- Dilute the product in water in a variable percentage from 2 to 20%, according to the degree of dirt to be removed.
- Hand wash: apply with a nebulizer, spread with a sponge or scrubbing brush and rinse.
- Automatic wash: pour the diluted product in the detergent tank and continue with washing cycle.

## Liquid detergent for leather and artificial leather



- Multi-purpose liquid product to dilute for a deep cleaning of tapestry of leather, artificial leather, sky, plastic, carpet and lacquered surfaces.
- Suitable also for inside car coverings, chairs and sofas of leather and artificial leather, plastic interiors.
- It cleans, renews colours and eliminates bad smells from motor vehicle interiors.

### HOW TO USE IT:

- Dilute the product in 1/10 in water (1 litre of product in 5 - 10 litres of water).
- Vaporise on the parts to clean or use a sponge immersed in the product, rinse and let it dry naturally.

Code	Desc.	Cont. Lt
4110015940	3280	5



## Liquid detergent odour destroyer



- Deep cleaning detergent, sanitizing, odour destroyer, for deep cleaning, sanitizing and complete elimination of odours due to the transportation and storage of foodstuff.
- Indicated for the manual washing of closed atmosphere, like freezers, containers, warehouse with washable walls, etc.
- The product diluted according to the instructions, allows a perfect cleaning of the environment and the elimination of strong and persistent odours that could contaminate later stored products.
- The product is not dangerous or harmful for the human health.

### HOW TO USE:

- Dilute the product in water in a percentage of 20% (one part of product in 4 part of water). Spray the product on the surfaces to be cleaned, wait 10 min. And rinse well.

Code	Desc.	Cont. Lt
4110016210	3915	5
4110016430	4025	25

## Deodorant sanitizing for interiors



- A cleansing smell of odors with deodorant for the elimination of molds, mushrooms and bad odors inside the car interior and air conditioning systems.
- Suitable for use by car washers, car dealerships, mechanics, electrodes, etc.
- The use of the properly diluted product eliminates any cause of bad odors inside the interior, refreshes the air, allows to sanitize antipollen filters, air conditioning ducts and dashboard vents. Sprayed on mats and upholstery leaves a light and persistent scent for several days.
- It does not stain the upholstery, does not mark the plastics, metals and wood that may be present, can be used on the carpet, on the mats, on the seats. Spraying on the anti-sponge filter helps to block the dust and spreads a good smell at every ignition of the air conditioner. Sprayed in the nozzles eliminates dust, mites and molds.
- METHOD OF USE:
- Dilute from a minimum of 1: 1 for a high efficiency up to a maximum of 1: 3 in water. Spray the product with a vaporizer on the surfaces to be sanitized. The product can also be placed in self-service automatic systems.

Code	Desc.	Content Kg	Fragrance
4110019570	6145	5	Lavender
4110019580	6150	5	Orange
4110019590	6155	5	Pine

## Hygiene disinfectant



- Product prepared for disinfection, detergence and neutralization of any kind of unpleasant smell and in closed rooms.
- It can be used in any room with mould, bacteria, bad smells due to the most various causes.
- Ideal for close rooms, like car and caravan interiors, garages, cellars, wc, goods loading and unloading rooms, sewage, etc.
- Very good to hygienically clean the vehicle interiors after having washed them with our products like: 411 00 15940 - 3280- detergent for leather and sky; or 411 00 15930 - 3275 detergent for tapestry-washers.
- It can also be used for the neutralisation of bad smells after the washing of rubbish skips.
- It forms no foam, it doesn't stain any kind of surface, it doesn't deodorize but neutralizes at once bad and persistent smells, like the ones left inside the vehicles by smoke and transported animals.
- Product to dilute 1/20-30 in water.

### HOW TO USE IT

- Dilute the product in the indicated proportions, then vaporize on the surfaces to deterge: chairs, plastic surfaces, pavements, vehicle tops, panels in general.
- Let it dry naturally.

Code	Desc.	Cont. Lt
4110015950	3285	5

## Nanocleaner detergent system for quick cleaning



- Nanotechnological detergent for use with turbo cleaner gun.
- The product uses nanotechnology particles to obtain deep cleansing within low-foam fabric.
- Nanocleaner achieves great results on all fabric surfaces such as padded seats, carpets, convertible canopy, sun awnings, etc.
- In addition to remarkable cleansing of fabric surfaces, nanocleaner revives the colors by releasing a pleasing fragrance.
- Nanocleaner can be used pure in cases of particularly dirty or diluted water in the ratio of 1 to 2 (1 liter of product in 2 l of water). Use according to the instructions contained within the turbo cleaner gun cod. 418 00 07800-5702.

Code	Desc.	Content It
4110017660	4460	5

## Liquid detergent for fabrics



- Low foam cleaning product for cleaning fabrics of seats, backs, carpets of cars, vans, buses, V.I.
- This article is for car dealers, car dealerships and car drivers, coaches, private coaches.
- The product is diluted as per instructions. can be used with extruded or spraying machines on the surface to be treated with normal pressure dispensers (eg 411 00 01201 - 2003 or 411 00 01205-2004) after application leave to act for a few minutes and dry with clean skin or rag. Do not rinse.
- Dilution in water can vary from 1: 7 to 1:20 depending on the intensity and nature of the dirt to be removed.
- The tissue cleaner revitalizes the interior colors of the car, smells gently, contains no ammonia. Can be used on carpets, fabrics, velvet, vinyl and sky. Do not use on leather surfaces.

Code	Desc.	Qty. kg.
4110018470	5050	5
4110018460	5045	25

## Rinnovatore liquido per plastiche esterne - without silicones



- Produced to polish crumbled plastic bands faded and deteriorated by weathering agents, aggressive washing and stubborn dirt.
- Particularly suitable for trucks, car dealers, car washers, washer trucks, haulers, nautical sector.
- Suitable item for refreshing and returning to external plastic parts such as bumpers, moldings, underrun of all types of cars or trucks. Can also be successfully used as a renewal and protective for engine compartments after washing.
- Solvent-free, silicone free product, quickly evaporates without leaving oily residues.
- Apply clean with our or with soaked sponge and wrap with a dry, clean cloth. The product does not stain and leaves any residue.

Code	Desc.	Cont. Lt
4110018480	5055	5

## Hydrobrilliant wax



- It is a product used on automatic washing plants before drying.
- It gives a bright and polished effect to any kind of car body and painting.
- It forms a thin protection on the car body preserving it for a long time from corrosion and the attack of the atmospheric agents.
- It is water-repellent, it lets water drops run away from the car body.

Code	Desc.	Cont. Lt
4110000009	9	5



## Black spray tyres



- Spray product protecting and polishing rubber parts, giving back a new aspect to all car details.
- It forms a transparent film sticking to the rubber, protecting it from cold and atmospheric agents, giving it also a brilliant aspect and eliminating stains and fades.
- It doesn't absolutely stain rims and coverrims.
- **HOW TO USE IT**
- Spray the product uniformly from a distance of about 20 cm on the parts to treat.
- Do not spray on the braking system.

Code	Desc.	Content ml
4110015260	2880	500

## PNEUS BLACK polish for tyres



- Product purposely studied to revive vehicle tyres, carmats and all rubber parts.
- It avoids the hardening and the chapping of the treated part.
- It gives back the original natural aspect.
- Biodegradable over 90%.
- Available also in 5 and 20 Lt cans, or with 500 ml. vaporiser. ready for use.
- **HOW TO USE IT**
- Dilute the product from 1:1 to 1:5 in water.
- Put the product on with a brush our code 443 00 33920-385/60, sponge our code 446 00 03100 3966, or pressure supplying valves cod 411 00 01201-2003 or 411 00 01205-2004.
- Do not use under the sun.

Code	Desc.	Cont. ml
4110000856	1383	5.000
4110000858	1385	20.000
4110015550	3085	500

## Wax remover for vehicles with polymeric cover



- It is a product made up of special solvents studied to eliminate protective wax, dirt and impurities from the bodies of new cars of European origin.
- It doesn't eat into paints, chromium-plated parts and rubber parts.
- Suitable also to degrease machine tools, engine block frames, garage pavements.
- For wax removal it is advised to spray the product diluted by 3% - 4% in hot water 80-90°C and rinse with a hydrocleaner.

Code	Desc.	Cont. Lt
4110002500	2611	5



## Wax remover for vehicles with paraffin cover



- It is a product made up of special solvents studied to eliminate protective wax, dirt and impurities from the bodies of new cars or extra-europe built cars or cars transported by SEA.
- It doesn't eat into paints, chromiumplated parts and rubber parts.
- For wax removal it is advised to spray the product diluted by 3% - 4% in hot water 80-90°C and rinse with an hydrocleaner.

Code	Desc.	Cont. Lt
4110014610	2734	5

## Complete formula industrial descaling liquid



- Acid descaling liquid for removing mortar, cement, plaster, encrustations and rust from equipment, such as cement-mixing machinery, shovels, pickaxes, trowels, tanks, etc.
- For use by builders, transport companies, cement manufacturers and transporters.
- Particularlly indicated for cleaning cement mixers without having to manually clean it.
- The product can be used neat or diluted in cold or hot water, depending on the consistency or the age of the encrustation to remove.
- Suitable for any type of unpainted metal surfaces; iron, steel, aluminium, copper and structural wood. do not use on galvanised panels, chromed parts and untreated wood.
- After descaling, the material treated must be carefully rinsed to eliminate any corrosive action of the product.

Code	Desc.	Cont. KG
4110017370	4330	20

## Springing for drains fast acting



- Gushing fast acting. Free pipes, without causing damage, from any kind of obstruction or clogging of an organic nature.
- It is recommended for maintenance of drains and drains because it eliminates: rags, cardboard, gauze, fats, detergents, calcination, etc.
- Respect without damaging pipes, metal parts, porcelain, etc.
- **METHOD OF USE:** remove excess water from the drain, pour the product slowly using a funnel and gloves. leave for 5 minutes. Slowly add a little cold water and then slide water thoroughly. Do not dilute the gushing with other products.
- Recommended intake for unclogging sinks 1/4 of the bottle, toilets 1/3 to 1/2 bottle.
- We recommend the use of gushing as prevention periodic meta 'of the doses indicated above.
- It contains sulfuric acid to handle and transfer carefully.

Code	Desc.	Cont. Lt
4110017970	4610	1

## Absorbing powder



- It is a powerful mineral absorbing agent (calcined sepiolite at 800°).
- It has a high capacity of absorption, very quickly it absorbs: oils, greases, liquids of any kind, hydrocarbons, aromatic products, alkaloids and chlorinated.
- It has very good anti-slipping properties, it is unflammable, it is chemically inert and it is not abrasive.
- Easily removable.
- odourless.
- Not harmful for flora and fauna, it is not toxic, you can handle it without any problem.
- Used successfully in all industries, car shops, foundries, factories, shipyards, etc.

Code	Desc.	Content
4110014915	2795	10 Kg tub
4110017460	4370	20 Kg bag

Technical Features	
Superficie specifica mq/g	350
Punto di fusione	1550°C
Absorption of xylene	45-50.60
Oil absorption	75-85%
Water absorption (FORD)	110.130%
Indice shell kg/cmq	3,5
Real specific density	1000
Apparent density g/lit.	500-600
Peso specifico	2100 g/lit
Size of the main cells	1500x9x3
Particle size means	800mu x 25mu x 4mu
Solubilità in acqua	INSOLUBILE
Color	CLEAR

## Absorbent inert mineral



- Universal, non - slip, completely inert, non - damaging, non - toxic, non - flammable absorbent granules for the absorption of any type of liquid spillage: oils, refrigerant liquids, hydraulic fluids, emulsified and whole oils, fuels, solvents, etc.
- Suitable for use in all types of workshop and workshop, for any type of workmanship, yards and roads for the absorption of spills due to accidents. It absorbs liquids and, once swept, leaves the surface perfectly clean and dry.
- The product does not melt in contact with liquids, remains compact and solid, has excellent anti-slip properties and is in compliance with EU CEN TS 15366: 2010 standard for use on cleaning roads following product accidents and leaks inflammable liquids. It allows for perfect surface cleaning, reduced use of absorbent product due to its high absorbent capacity and safe use in the food industry due to the absolute absence of harmful or toxic substances such as asbestos, silica free or similar.

Code	Desc.	Dimension granules mm	Color	Content Kg
4110019380	5985	0,80 - 2,00	White milk	10



## Assorbente neutralizzante per acido batterie

- Absorbent and neutralizing product for cleaning spills of acid solutions for batteries (sulfuric acid), approved and certified according to Ministerial Decree No. 20 of January 24, 2011.
- Required practically in all workplaces, stores, workshops, storage places where there are lead acid batteries, commonly used on trucks, lorries and conveyors, electric vehicles, etc. Depending on the number and capacity of the batteries present, there must be sufficient presence of absorbent and neutralizing agent to be used in the event of accidents and accidents.
- Various packages are available to make the necessary supplies to any need. The material has a deadline imprinted on each pack, and must be replaced upon its arrival. To calculate the quantity of absorbent to be purchased, it must be taken into account that it absorbs and neutralizes 1 liter of acid every 650 grams of product.
- **METHOD OF USE:**
- Use as a normal absorbent, sprinkle it around the acid and cover it. The product will absorb the soured acid and then, within a few minutes, neutralize it by resetting the acidity itself.
- The compound thus obtained can be disposed of as a special non-hazardous waste, and in accordance with A.D.R.

### Sacchi da 7 Kg



- Sacchi di assorbente e neutralizzante da 7 kg, in grado di trattare una quantita' massima di acido sversato pari a 12,9 litri (sufficiente per il contenuto di una batteria da avviamento da 100 ah).
- Prodotto certificato dal politecnico di Torino.

Code	Description	Content Kg
4110019670	6195	7

### Valigetta da 14 kg uso elettrauto (25 litri)



- Valigetta pronta all'uso con tutto l'occorrente per l'utilizzo da parte di elettrauto, meccanici, autocarrozzerie, ecc.
- Valigetta in materiale plastico antiurto dimensioni 450 x 390 x 129 mm.
- Contenuto: 2 sacchi di assorbente neutralizzante per acido batterie da 7 kg, 2 fogli assorbenti gialli da 400 x 500 mm, 1 sacco nero per lo smaltimento, 1 scopino con paletta per il raccoglimento del prodotto usato.
- Prodotto certificato dal politecnico di torino.
- Contenuto:
- 2 Sacchi di assorbente e neutralizzante da 7 Kg
- 2 Panni assorbenti 500 X 400 mm
- 1 Sacco per smaltimento rifiuto
- 1 Scopino con paletta

Code	Description
4110019680	6200



## Hygiene product for helmets



ΑΦΡΟΣ ΚΑΘΑΡΙΣΜΟΥ ΓΙΑ ΚΡΑΝΗ 200 ML

ΠΡΟΪΟΝ ΕΝΕΡΓΟΥ ΙΟΝΙΣΜΕΝΟΥ ΑΦΡΟΥ ΓΙΑ ΤΟΝ ΚΑΘΑΡΙΣΜΟ ΚΑΙ ΤΗΝ ΑΠΟΛΥΜΑΝΣΗ ΤΟΥ ΕΣΩΤΕΡΙΚΟΥ ΤΟΥ ΚΡΑΝΟΥΣ. ΔΡΑ ΓΡΗΓΟΡΑ ΚΑΙ ΕΓΓΥΑΤΑ ΒΑΘΥ ΚΑΘΑΡΙΣΜΟ. ΑΠΟΜΑΚΡΥΝΕΙ ΤΑ ΒΑΚΤΗΡΙΑ, ΤΟΥΣ ΛΕΚΕΔΕΣ, ΤΗΣ ΔΥΣΑΡΕΣΤΕΣ ΟΣΜΕΣ ΚΑΙ ΤΑ ΥΠΟΛΕΙΜΜΑΤΑ ΣΚΟΝΗΣ. ΜΙΚΡΗ ΚΑΙ ΠΡΑΚΤΙΚΗ ΣΥΣΚΕΥΑΣΙΑ ΓΙΑ ΕΥΚΟΛΗ ΑΠΟΘΗΚΕΥΣΗ ΚΑΙ ΜΕΤΑΦΟΡΑ. ΚΡΑΤΑΤΕ ΑΝΑΠΟΔΑ ΤΗΝ ΦΙΑΛΗ ΚΑΤΑ ΤΗΝ ΔΙΑΡΚΕΙΑ ΤΗΣ ΧΡΗΣΗΣ.

Code	Desc.	Cont. ml
4110015330	2940	200

## Motorcycle chains wash



ΚΑΘΑΡΙΣΤΙΚΟ ΑΛΥΣΙΔΑΣ 400ML

ΕΠΑΓΓΕΛΜΑΤΙΚΟ ΠΡΟΪΟΝ ΓΙΑ ΤΟ ΠΛΥΣΙΜΟ ΑΛΥΣΙΔΑΣ. ΚΑΘΑΡΙΖΕΙ ΤΟΥΣ ΕΝΤΟΝΟΥΣ ΚΑΙ ΔΥΣΚΟΛΟΥΣ ΛΕΚΕΔΕΣ ΑΠΟ ΓΡΑΣΟ ΛΑΔΙ ΚΑΥΣΙΜΟ ΚΤΛ. ΔΕΝ ΠΡΟΣΒΑΛΕΙ ΤΙΣ ΕΠΙΧΡΩΜΙΩΜΕΝΕΣ ΕΠΙΦΑΝΕΙΕΣ ΤΟ ΚΑΟΥΤΣΟΥΚ ΤΑ Ο-RING ΤΑ ΠΛΑΣΤΙΚΑ ΜΕΡΗ Η ΤΗΝ ΒΑΦΗ. ΚΑΤΑΛΛΗΛΟ ΓΙΑ ΤΗΝ ΑΠΟΛΙΠΑΝΣΗ ΚΑΙ ΤΟΝ ΚΑΘΑΡΙΣΜΟ ΜΗΧΑΝΙΚΩΝ ΜΕΡΩΝ.

Code	Desc.	Cont. ml
4110015320	2930	400



ΣΠΡΕΥ ΓΡΑΣΣΟ ΑΛΥΣΙΔΑΣ 400ML

ΣΠΡΕΙ ΛΕΥΚΟΥ ΓΡΑΣΟΥ ΕΙΔΙΚΟ ΓΙΑ ΤΗΝ ΜΕΙΩΣΗ ΤΩΝ ΤΡΙΒΩΝ ΣΤΙΣ ΑΛΥΣΙΔΕΣ ΜΟΤΟΣΥΚΛΕΤΩΝ ΑΚΟΜΗ ΚΑΙ ΑΝ Η ΑΛΥΣΙΔΑ ΕΙΝΑΙ ΤΥΠΟΥ Ο-RING (ΑΥΤΟΛΙΠΑΙΝΟΜΕΝΗ). ΔΙΕΙΣΔΥΕΙ ΣΕ ΒΑΘΟΣ ΠΡΙΝ ΣΤΕΓΝΩΣΕΙ. ΔΕΝ ΠΙΤΣΙΛΑ ΑΚΟΜΑ ΚΑΙ ΣΕ ΠΟΛΥ ΥΨΗΛΕΣ ΤΑΧΥΤΗΤΕΣ. ΚΑΤΑΛΛΗΛΟ ΚΑΙ ΓΙΑ ΑΓΩΝΙΣΤΙΚΑ ΜΟΝΤΕΛΑ. ΜΙΚΡΗ ΚΑΙ ΠΡΑΚΤΙΚΗ ΣΥΣΚΕΥΑΣΙΑ ΓΙΑ ΕΥΚΟΛΗ ΑΠΟΘΗΚΕΥΣΗ ΚΑΙ ΜΕΤΑΦΟΡΑ.

Code	Desc.	Content	Color
4110015325	2935	200 ml	WHITE
4110301700	59 kit	12 pcs. + Display box	-



## Spray grease for motorcycle chains



- Spray grease specific for the reduction of frictions on motorcycle chains, also the selflubricating kind with or links.
- High migratory power, allowing the product to penetrate deeply before drying up.
- The high toughness avoids sprays and purts even at the highest speeds.
- Suitable for sports and racing.

### HOW TO USE IT

- Spray from a distance of about 20 cm on the part to treat.
- Wait for the solvent to have evaporated before starting again.

Code	Desc.	Content	Color
4110015325	2935	200 ml	WHITE
4110301700	59 kit	12 pcs. + Display box	-

## Motorcycle chains wash



- Technical professional product to wash chains. It eliminates easily intense and difficult dirt like: grease, oil, fuels, etc.
- It doesn't eat into chromium-plated surfaces, in rubber, or, plastic and painted surfaces.
- Suitable also for the degreasing and cleaning of mechanical parts.
- **HOW TO USE IT**
- Spray the product on the parts to treat and let it act for some minutes.
- If necessary repeat the operation.

Code	Desc.	Cont. ml
4110015320	2930	400

## Cleansing foam for motorcycles



- Foaming liquid detergent specifically for washing motorcycles and their parts, even the most 'delicate'. usable for washing by hand and runs for self-service.
- Suitable for dealerships and retail motorcycle and scooter, car washes, motorcycle workshop.
- The product is applied in dilutions recommended by spraying it on the totality 'motorcycle.
- Will be formed 'an active foam persistent dissolve' the dirt, grease, insects, dirt from the wheels. After rinsing with water under high pressure the whole vehicle will be 'clean and shining.
- Not 'aggressive surfaces more' delicate as alloy wheels, aluminum alloys, paints, stainless steel and composite fibers. even more effective with the waters' harsh. It prevents the formation of limestone.
- Leaves no leakage or halos.
- How to use
- Dilute the product according to the application table or do aspirate pure from the dosing pump of the system.
- Spray on the entire surface of the vehicle so that it forms a persistent foam.
- Leave for a few minutes and rinse with water under high pressure.

TIPO DI SPORCO	USO MANUALE		USO AUTOMATICO/PISTE	
	Prodotto: Acqua	%	ml per veicolo	%
Pesante	1:20 - 1:25	5-4	60	3
Medio	1:25 - 1:30	4-3,5	50	2,5
Leggero	1:30 - 1:40	3,5-2,5	40	2

Code	Description	Content Kg
4110019610	6165	5

## Medium threading lock



ΑΣΦΑΛΙΣΤΙΚΟ ΣΠΕΙΡΩΜΑΤΟΣ ΜΕΤΡΙΑΣ ΜΗΧΑΝΙΚΗΣ ΑΝΤΙΣΤΑΣΗΣ ΧΡΩΜΑΤΟΣ ΓΑΛΑΖΙΟ. ΜΠΟΡΕΙ ΝΑ ΧΡΗΣΙΜΟΠΟΙΗΘΕΙ ΣΕ ΟΛΑ ΤΑ ΜΕΤΑΛΛΑ, ΣΕ ΣΥΝΑΡΜΟΓΕΣ ΚΙΝΗΣΗΣ ΚΑΙ ΤΡΙΒΗΣ. ΕΙΝΑΙ ΚΑΤΑΛΛΗΛΟ ΓΙΑ ΤΗΝ ΑΣΦΑΛΙΣΗ ΒΙΔΩΝ, ΠΑΞΙΜΑΔΙΩΝ Η ΑΛΛΩΝ ΕΞΑΡΤΗΜΑΤΩΝ ΜΕ ΣΠΕΙΡΩΜΑ, ΠΑΡΕΧΟΝΤΑΣ ΤΗ ΔΥΝΑΤΟΤΗΤΑ ΑΠΟΣΥΝΑΡΜΟΛΟΓΗΣΗΣ ΜΕ ΚΟΙΝΑ ΕΡΓΑΛΕΙΑ. ΑΝΘΕΚΤΙΚΟ ΣΕ ΘΕΡΜΟΚΡΑΣΙΕΣ ΑΠΟ -55°C ΕΩΣ +150°C. ΑΝΘΕΚΤΙΚΟ ΣΕ ΚΡΑΔΑΣΜΟΥΣ. ΑΝΘΕΚΤΙΚΟ ΣΕ ΛΑΔΙΑ, ΚΑΥΣΙΜΑ, ΨΥΚΤΙΚΑ ΚΑΙ ΧΗΜΙΚΑ.

Code	Desc.	Content ml	Color
4090000500	AN 302-42	50	BLUE

PROPRIETÀ FISICHE	
VISCOSITÀ (25°C - MPA.S)	1000
PESO SPECIFICO (GR./ML.)	1,05
DIAM. MAX. FILETTO/TOLLERANZA MAX. GIUNTO	M 36/0,25 mm
PUNTO DI INFIAMMABILITÀ	>100°C
CONTENUTO DI SOLVENTI	nessuno

CARATTERISTICHE DI POLIMERIZZAZIONE	
TEMPO DI MANIPOLAZIONE	10/20 minuti
TEMPO DI INDURIMENTO FUNZIONALE	3 ore
TEMPO DI INDURIMENTO FINALE	5-10 ore
RESISTENZA A SVITAMENTO INIZIALE	4,0-8,5 N/mm <sup>2</sup>
RESISTENZA A SVITAMENTO RESIDUA	2,0-4,0 N/mm <sup>2</sup>
RESISTENZA A SCORRIMENTO/TAGLIO	8,0-12,0 N/mm <sup>2</sup>

## Strong threading lock



ΑΣΦΑΛΙΣΤΙΚΟ ΣΠΕΙΡΩΜΑΤΟΣ ΥΨΗΛΗΣ ΜΗΧΑΝΙΚΗΣ ΑΝΤΙΣΤΑΣΗΣ ΧΡΩΜΑΤΟΣ ΠΡΑΣΙΝΟ. ΜΠΟΡΕΙ ΝΑ ΧΡΗΣΙΜΟΠΟΙΗΘΕΙ ΣΕ ΟΛΑ ΤΑ ΜΕΤΑΛΛΑ, ΣΕ ΣΥΝΑΡΜΟΓΕΣ ΚΙΝΗΣΗΣ ΚΑΙ ΤΡΙΒΗΣ. ΕΙΝΑΙ ΚΑΤΑΛΛΗΛΟ ΓΙΑ ΤΗΝ ΜΟΝΙΜΗ ΑΣΦΑΛΙΣΗ ΒΙΔΩΝ, ΠΑΞΙΜΑΔΙΩΝ Η ΑΛΛΩΝ ΕΞΑΡΤΗΜΑΤΩΝ ΜΕ ΣΠΕΙΡΩΜΑ. ΑΝΘΕΚΤΙΚΟ ΣΕ ΘΕΡΜΟΚΡΑΣΙΕΣ ΑΠΟ -55°C ΕΩΣ +150°C. ΑΝΘΕΚΤΙΚΟ ΣΕ ΚΡΑΔΑΣΜΟΥΣ. ΑΝΘΕΚΤΙΚΟ ΣΕ ΛΑΔΙΑ, ΚΑΥΣΙΜΑ, ΨΥΚΤΙΚΑ ΚΑΙ ΧΗΜΙΚΑ.

Code	Desc.	Content ml	Color
4090000800	AN 302-70	50	GREEN

PROPRIETÀ FISICHE	
VISCOSITÀ (25°C - MPA.S)	500-600
PESO SPECIFICO (GR./ML.)	1,1
DIAM. MAX. FILETTO/TOLLERANZA MAX. GIUNTO	M 20/0,15 mm
PUNTO DI INFIAMMABILITÀ	>100°C
CONTENUTO DI SOLVENTI	nessuno

CARATTERISTICHE DI POLIMERIZZAZIONE	
TEMPO DI MANIPOLAZIONE	10/20 minuti
TEMPO DI INDURIMENTO FUNZIONALE	1-3 ore
TEMPO DI INDURIMENTO FINALE	5-10 ore
RESISTENZA A SVITAMENTO INIZIALE	9,0-13,0 N/mm <sup>2</sup>
RESISTENZA A SVITAMENTO RESIDUA	13,0-17,0 N/mm <sup>2</sup>
RESISTENZA A SCORRIMENTO/TAGLIO	12,0-15,0 N/mm <sup>2</sup>

## Red gasket maker

TIPO ELASTICO PER SMONTAGGI FACILI



ΓΙΑ ΤΗ ΣΤΕΓΑΝΟΠΟΙΗΣΗ ΚΙΒΩΤΙΩΝ ΤΑΧΥΤΗΤΩΝ, ΓΡΑΝΑΖΙΩΝ, ΔΙΑΦΟΡΙΚΩΝ, ΑΝΤΛΙΩΝ ΚΑΙ ΦΛΑΝΤΖΩΝ ΚΙΝΗΤΗΡΩΝ. ΑΝΘΕΚΤΙΚΟ ΣΕ ΚΡΑΔΑΣΜΟΥΣ. ΑΝΘΕΚΤΙΚΟ ΣΕ ΑΠΟΤΟΜΕΣ ΑΛΛΑΓΕΣ ΘΕΡΜΟΚΡΑΣΙΑΣ, ΠΕΠΙΣΜΕΝΟ ΑΕΡΑ, ΝΕΡΟ, ΑΕΡΙΟ, LPG, ΛΑΔΙΑ ΚΑΙ ΚΑΥΣΙΜΑ, ΧΗΜΙΚΑ. ΑΝΘΕΚΤΙΚΟ ΣΕ ΘΕΡΜΟΚΡΑΣΙΑΣ ΑΠΟ -55°C ΕΩΣ +150°C. ΟΙ ΣΤΕΓΑΝΟΠΟΙΗΜΕΝΕΣ ΕΝΩΣΕΙΣ ΜΠΟΡΟΥΝ ΝΑ ΑΠΟΣΥΝΑΡΜΟΛΟΓΗΘΟΥΝ ΜΕ ΚΟΙΝΑ ΕΡΓΑΛΕΙΑ.

Code	Desc.	Content
4090001050	AN 305-10	50 ml - TUBE
4090001060	AN 305-10 S	75 gr - BELLOWS

PROPRIETÀ FISICHE	
VISCOSITÀ (25°C - MPA.S)	80.000 - 120.000
PESO SPECIFICO (GR./ML.)	1,05
DIAM. MAX. FILETTO/TOLLERANZA MAX. GIUNTO	0,5a0 mm
PUNTO DI INFIAMMABILITÀ	>100°C
CONTENUTO DI SOLVENTI	nessuno

CARATTERISTICHE DI POLIMERIZZAZIONE	
TEMPO DI MANIPOLAZIONE	10-20 minuti
TEMPO DI INDURIMENTO FUNZIONALE	3-6 ore
TEMPO DI INDURIMENTO FINALE	6-12 ore
RESISTENZA A SVITAMENTO INIZIALE	5-7 N/mm <sup>2</sup>
RESISTENZA A SVITAMENTO RESIDUA	6-8 N/mm <sup>2</sup>
RESISTENZA A SCORRIMENTO/TAGLIO	5-10 N/mm <sup>2</sup>



## Green gasket maker

TIPO ELASTICO PER  
SMONTAGGI FACILI



ΑΝΤΙΚΑΘΙΣΤΑ ΠΡΟΔΙΑΜΟΡΦΩΜΕΝΕΣ ΤΣΙΜΟΥΧΕΣ. ΓΙΑ ΤΗ ΣΤΕΓΑΝΟΠΟΙΗΣΗ ΚΙΒΩΤΙΩΝ ΤΑΧΥΤΗΤΩΝ, ΓΡΑΝΑΖΙΩΝ, ΔΙΑΦΟΡΙΚΩΝ, ΑΝΤΛΙΩΝ ΚΑΙ ΦΛΑΝΤΖΩΝ ΚΙΝΗΤΗΡΩΝ. ΑΝΘΕΚΤΙΚΟ ΣΕ ΚΡΑΔΑΣΜΟΥΣ. ΑΝΘΕΚΤΙΚΟ ΣΕ ΑΠΟΤΟΜΕΣ ΑΛΛΑΓΕΣ ΘΕΡΜΟΚΡΑΣΙΑΣ, ΠΕΠΙΕΣΜΕΝΟ ΑΕΡΑ, ΝΕΡΟ, ΑΕΡΙΟ, LPG, ΛΑΔΙΑ ΚΑΙ ΚΑΥΣΙΜΑ, ΧΗΜΙΚΑ. ΑΝΘΕΚΤΙΚΟ ΣΕ ΘΕΡΜΟΚΡΑΣΙΑΣ ΑΠΟ -55°C ΕΩΣ +150°C. ΟΙ ΣΤΕΓΑΝΟΠΟΙΗΜΕΝΕΣ ΕΝΩΣΕΙΣ ΜΠΟΡΟΥΝ ΝΑ ΑΠΟΣΥΝΑΡΜΟΛΟΓΗΘΟΥΝ ΜΕ ΚΟΙΝΑ ΕΡΓΑΛΕΙΑ.

Code	Desc.	Content
4090001300	AN 305-73	50 ml - TUBE
4090001310	AN 305-73 S	75 gr - BELLOWS

PROPRIETÀ FISICHE	
VISCOSITÀ (25°C - MPA S)	17.000 - 30.000
PESO SPECIFICO (GR./ML.)	1,05
DIAM. MAX. FILETTO/TOLLERANZA MAX. GIUNTO	0,30 mm
PUNTO DI INFIAMMABILITÀ	>100°C
CONTENUTO DI SOLVENTI	nessuno

CARATTERISTICHE DI POLIMERIZZAZIONE	
TEMPO DI MANIPOLAZIONE	15-30 minuti
TEMPO DI INDURIMENTO FUNZIONALE	3-6 ore
TEMPO DI INDURIMENTO FINALE	6-24 ore
RESISTENZA A SVITAMENTO INIZIALE	4-6 N/mm <sup>2</sup>
RESISTENZA A SVITAMENTO RESIDUA	2-4 N/mm <sup>2</sup>
RESISTENZA A SCORRIMENTO/TAGLIO	2-4 N/mm <sup>2</sup>
ALLUNGAMENTO A ROTTURA	oltre 100%

## Bearing-lock

SMONTABILE



### ΚΟΛΛΑ ΡΟΥΛΕΜΑΝ 50ML

ΑΣΦΑΛΙΣΤΙΚΟ ΕΔΡΑΝΩΝ. ΑΝΑΕΡΟΒΙΟΣ ΠΑΡΑΓΟΝΤΑΣ ΑΣΦΑΛΙΣΗΣ ΠΟΥ ΕΠΙΤΡΕΠΕΙ ΤΗΝ ΑΠΟΣΥΝΑΡΜΟΛΟΓΗΣΗ ΕΔΡΑΝΩΝ, ΔΑΚΤΥΛΙΩΝ ΚΑΙ ΠΑΡΑΛΛΗΛΟΥΣ ΣΥΝΔΕΣΜΟΥΣ ΜΕ ΚΟΙΝΑ ΕΡΓΑΛΕΙΑ. ΜΠΟΡΕΙ ΝΑ ΧΡΗΣΙΜΟΠΟΙΗΘΕΙ ΣΕ ΟΛΑ ΤΑ ΜΕΤΑΛΛΑ, ΣΕ ΣΥΝΑΡΜΟΓΕΣ ΚΙΝΗΣΗΣ ΚΑΙ ΤΡΙΒΗΣ. ΑΝΘΕΚΤΙΚΟ ΣΕ ΚΡΑΔΑΣΜΟΥΣ, ΛΑΔΙΑ, ΚΑΥΣΙΜΑ, ΨΥΚΤΙΚΑ ΚΑΙ ΧΗΜΙΚΑ. ΑΝΘΕΚΤΙΚΟ ΣΕ ΘΕΡΜΟΚΡΑΣΙΑΣ ΑΠΟ -55°C ΕΩΣ +150°C.

Code	Desc.	Content ml	Color
4090001900	AN 306-41	50	RED

PROPRIETÀ FISICHE	
VISCOSITÀ (25°C - MPA S)	550
PESO SPECIFICO (GR./ML.)	1,05
DIAM. MAX. FILETTO/TOLLERANZA MAX. GIUNTO	0,12 mm.
PUNTO DI INFIAMMABILITÀ	>100°C
CONTENUTO DI SOLVENTI	nessuno

CARATTERISTICHE DI POLIMERIZZAZIONE	
TEMPO DI MANIPOLAZIONE	10-20 minuti
TEMPO DI INDURIMENTO FUNZIONALE	1-3 ore
TEMPO DI INDURIMENTO FINALE	3-6 ore
RESISTENZA A SVITAMENTO INIZIALE	4-6 N/mm <sup>2</sup>
RESISTENZA A SVITAMENTO RESIDUA	4-8 N/mm <sup>2</sup>
RESISTENZA A SCORRIMENTO/TAGLIO	8-12 N/mm <sup>2</sup>
RESISTENZA ALL'URTO	1-5 N/mm <sup>2</sup>



## Bearing-lock

SMONTABILE



- It is an anaerobic locking compound allowing a possible disassembly of bearings, ferrules and parallel couplings with common tools.
- It can be used on all metals, both in running and friction fits.
- It resists vibrations, oils and fuels, freezing fluids and chemical agents.
- It resists temperatures between -55°C and +150°C.

Code	Desc.	Content ml	Color
4090001900	AN 306-41	50	RED

PROPRIETÀ FISICHE	
VISCOSITÀ (25°C - MPA.S)	550
PESO SPECIFICO (GR./ML.)	1,05
DIAM. MAX. FILETTO/TOLLERANZA MAX. GIUNTO	0,12 mm.
PUNTO DI INFIAMMABILITÀ	>100°C
CONTENUTO DI SOLVENTI	nessuno

CARATTERISTICHE DI POLIMERIZZAZIONE	
TEMPO DI MANIPOLAZIONE	10-20 minuti
TEMPO DI INDURIMENTO FUNZIONALE	1-3 ore
TEMPO DI INDURIMENTO FINALE	3-6 ore
RESISTENZA A SVITAMENTO INIZIALE	4-6 N/mm <sup>2</sup>
RESISTENZA A SVITAMENTO RESIDUA	4-8 N/mm <sup>2</sup>
RESISTENZA A SCORRIMENTO/TAGLIO	8-12 N/mm <sup>2</sup>
RESISTENZA ALL'URTO	1-5 N/mm <sup>2</sup>

## Quick locking compound

PER ACCOPPIAMENTI DI PRECISIONE DEFINITIVI



- Anaerobic locking compound to fix bearings, ferrules, pulleys, gears, small keys, plugs and parallel couplings in general.
- It allows to fix definitively both in free float and under press assembly.
- It resists vibrations, thermal sudden changes, oils and fuels, freezing fluids and chemical agents.
- It resists temperatures between -55°C and +150°C.

Code	Desc.	Content ml	Color
4090001600	AN 306-01	50	GREEN

PROPRIETÀ FISICHE	
VISCOSITÀ (25°C - MPA.S)	125
PESO SPECIFICO (GR./ML.)	1,1
DIAM. MAX. FILETTO/TOLLERANZA MAX. GIUNTO	M 12/0,1 mm
PUNTO DI INFIAMMABILITÀ	>100°C
CONTENUTO DI SOLVENTI	nessuno

CARATTERISTICHE DI POLIMERIZZAZIONE	
TEMPO DI MANIPOLAZIONE	5-10 minuti
TEMPO DI INDURIMENTO FUNZIONALE	1-3 ore
TEMPO DI INDURIMENTO FINALE	3-6 ore
RESISTENZA A SVITAMENTO INIZIALE	8-12 N/mm <sup>2</sup>
RESISTENZA A SVITAMENTO RESIDUA	12-16 N/mm <sup>2</sup>
RESISTENZA A SCORRIMENTO/TAGLIO	17,5-22,5 N/mm <sup>2</sup>
RESISTENZA ALL'URTO	11-15 N/mm <sup>2</sup>

## Loctite 270 strong threading lock



- It is a strong threading lock with high mechanical resistance, suitable to lock or seal permanently.
- Used on screws, bolts, studs and as anti-tampering protection.
- It resists temperatures between -55°C and +150°C.
- Specific weight: AB. 1,1.
- Inflammability point: > 100°C.
- Complete hardening: 24h at 22°C.
- Colour: fluorescent green.

Code	Desc.	Content ml
403000400	270	50

CARATTERISTICHE TECNICHE	
Dimensioni max filetto	Oltre M25
Resistenza	Alta
Resistenza funzionale	6 ore
Coppia di primo distacco bulloni M10	26Nm
Resistenza alla temperatura a lungo termine	+150°C
Peso specifico @ 25°C.	1,10

## Loctite 495 Adigomma



- It is a rapid adhesive with ethylic base.
- It quickly glues rubber, plastic materials, pottery, metals, ferrites, cork and other substrates.
- It is recommended to glue pottery and magnets, O.R., PVC.
- There is no need for a particular preparation of surfaces.
- Resistance to temperature: -50°C + 80°C.
- Colour: transparent.

Code	Desc.	Content gr.
4030001000	495	20

TEMPI DI FISSAGGIO (in sec.)	
MATERIE PLASTICHE	
PVC	3-10
Phenols	5-20
ABS	10-30
METALLI	
Acciaio dolce sgrassato	10-30
Alluminio sgrassato	5-15
Zinco bicromato	30-90
SUBSTRATI VARI	
Gomma nitrilica o neoprenica	meno di 5

## Cyanoacrylate adhesive Loctite 406



- It is an instant adhesive for rubbers and plastics.
- It has the property to wet surfaces very well.
- Colour: transparent.
- Hardening at 22°C: 12h.
- Resistance to temperature: -50°C + 80°C.

Code	Desc.	Content gr.
4030003500	406	20

TEMPI DI FISSAGGIO (in sec.)	
MATERIE PLASTICHE	
PVC	2-10
Phenols	5-15
ABS	2-10
METALLI	
Acciaio dolce sgrassato	10-20
Alluminio sgrassato	2-10
Zinco bicromato	30-90
SUBSTRATI VARI	
Gomma nitrilica o neoprenica	meno di 5

## Loctite 510 sealant 51037 (Pianermetic red)



- It is an anaerobic product, tixotropic (it doesn't drip), at high mechanical and chemical resistance.
- It seals metal planes on pressure die-cast components like gears, carter, pumps, reducers, etc.
- It assures the complete level surface of the surfaces by filling the microrooms due to the imperfect contacts of the parts.
- Very good resistance to solvents.
- It fills gaps as far as 0,40 mm.
- It seals pressures as far as 350 atm.
- The gasket produced has no movements after the application, therefore there is no need for the restoration of the tightening pair of bolts.
- Resistance to temperature: -55°C + 200°C.
- Colour: red.
- Inflammability point: > 100°C specific weight: AB. 1,16.
- It is used in mass-produced articles by the major industrial vehicle makers.

Code	Desc.	Content ml
4030001200	510	50

## Loctite 573 - 57335 (Pianermetic green)



- It is an anaerobic product, tixotropic (it doesn't drip), at low mechanical resistance for the sealing of exact planes, also with complex sections, but where there is need for easy disassembly.
- It assures the complete contact of the surfaces by filling the microrooms due to the imperfect contacts of the parts and can fill gaps as far as 0,10 mm.
- It doesn't have movements after the application, in time, therefore there is no need for the restoration of the tightening pair of bolts.
- Resistance to temperature: -55°C + 150°C.
- Complete hardening: 72 hours at 22°C.
- Colour: green.

Code	Desc.	Content ml
4030001500	573	50

## Loctite 542 seal coupling (Idraulermetic) 54237



- It is a liquid gasket to seal threaded couplings.
- It assures the complete contact of the parts by filling the gaps existing among the screw threads.
- It has a very good resistance to solvents and contains no particles that could clog the hydraulic and pneumatic filters.
- Used to seal hydraulic and pneumatic couplings, to seal industrial fluids or little pipings.
- Specific weight: 1,06 at 25°C.
- Resistance to temperature: -55°C + 150°C.
- Inflammability point: >100°C.
- Color: brown.
- Complete hardening: 24 hours at 22°C.

Code	Desc.	Content ml
4030001300	542	50

## Loctite 572 (Tubermetic) 57236



- It is a liquid gasket to seal threaded couplings, pipings for water, gas, switching-off systems, hydraulic and pneumatic systems, hose fitting in general as far as a diameter of 2".
- It assure the complete contact of the parts by filling the gaps existing among the screw threads.
- Very good resistance to solvents.
- Specific weight: ab. 1,25.
- Resistance to temperature: -55°C + 150°C.
- Inflammability point: > 100°C.
- Complete hardening: 72 hours at 22°C.
- Colour: white.

Code	Desc.	Content ml
4030001400	572	50

## Loctite Kit O-Ring



### CONTENUTO

Corda O-Ring ø 1,6 mm	circa 1,2 mt
Corda O-Ring ø 2,4 mm	circa 1,2 mt
Corda O-Ring ø 3,0 mm	circa 1,2 mt
Corda O-Ring ø 5,7 mm	circa 1,2 mt
Corda O-Ring ø 8,4 mm	circa 1,2 mt
n° 1 adesivo universale da 10 gr.	
n° 1 cutter	
n° 1 accessorio misuratore per taglio e incollaggio O-Ring	

- The O-Ring kit contains some nitrile rubber ropes of different diameter, a special tool to make the right cut and a rapid adhesive.
- The kit allows to make at once O-Ring of any dimension: you can cut the nitrile rubber rope perfectly and join it directly in a few seconds.
- Exploiting this opportunity, you will never again have to delay a reparation or leave a vehicle because of the lack of o-ring in the desired measure.

Code	Desc.
4030002000	12542

## Locking and sealing Loctite 243 to 32,178 (ex 803)



- And " a product anaerobic medium strength. Prevents loosening of nuts, bolts and screws, caused by vibration and shock.
- It seals threaded parts that need to guarantee a perfect seal.
- It replaces all traditional systems blocking such as nuts, washers, spring washers, pins, etc.
- Brakes the flywheel screws, carburetor and the differential housing, oil drain plugs, screws of the doors and various mechanisms.
- The parties may, however, be removed with normal tools.
- Temperature resistance: -55 ° C + 150 ° C.
- Blue color.
- Specific Gravity: 1.08 @ 25 ° c.
- Curing time: 72 hours.

Code	Desc.	Content ml
4030002850	243/10	10



## Loctite lock screws and bearings from 270 to 32,177 (ex 805)



- It is a strong anaerobic resin that hardens quickly. Designed for the mounting of bearings free instead at the press.
- A slight rotation during assembly ensures even distribution of the product, making it possible to replace bearings even when slots are worn.
- Restrain prisoners head and collectors.
- Lock the screws of the oil sump and gearbox.
- Fixed the camshaft sprocket and all the details that are to be blocked.
- The pieces can still be disassembled with normal tools.
- Temperature resistance: -55 ° C + 150 ° C.
- Color: green.
- Specific Gravity: 1.08 @ 25 ° c.
- Curing time: 72 hours

Code	Desc.	Content ml
4030000410	270/10	10

## Ferrule- and brass-lock Loctite 648-13807 (ex 807)



- It is an anaerobic resin with high mechanical resistance studied for the assembly and the fixing of cylindrical fits like: ferrules, brasses, valve-guides, cylinder liners, water pump impellers, pulleys and gears.
- The resin hardness in absence of air and by catalytic effect of metals, it spreads uniformly on the surfaces to join, assuring an even more persistent gluing than that of common assemblies fixed one into the other.
- The parts can be disassembled with common tools.
- Resistance to temperature: -55°C +150°C.
- Color: green.
- Specific weight: 1,13@ 25°C.
- Time of polymerisation : 72 hours.

Code	Desc.	Content ml
4030001750	648	50

## Wire sealing fittings Loctite®



- sealant multi-fiber nylon thread in plastic and metal.
- field of use: plant engineer hydraulic manutenzione, machine shop car.
- used in the sealing of threaded components, such as joints and pipe fittings. sealing fluids and not up to the temperature of 150 ° c.
- applicable on drinking water pipes, hot, cold, heating gas (including LPG) and oxygen gas.
- realizes a seal instantly to the assembly and allows the repositioning of the fillet.
- Certified: dvgw for gas and water: dv-5142au0166; imq gas for 1st, 2nd and 3rd family and hot water, according to en751-2 class arp and din30660; ktw for drinking water; wrc for drinking water up to 85 ° c; nsf / ansi; bam for gaseous oxygen at 20 bar and 60 ° c.
- packaging spool from 150 mt, with integrated cutter.

Code	Desc.	Characteristics
4110019450	6055	150 MT

## Loctite glass/metal adhesive kit 319-16914



- This kit is a system composed of an adhesive and a special nylon material treated with an activator for gluing rear-view mirrors to the windscreen.
- Ideal also for gluing other metal parts to glass. The gluing together of various materials is also possible: metal, glass, ceramic, plastic. Specific weight: 1.10 @ 25°C. Polymerisation time: 24 hours.

Code	Desc.
4030003450	319

## Loctite 5920-29965 ( ex Ultra Copper 19242)



- It is a silicone gasket maker with low smell, brass colour, studied for high performance engines like overfed, sports, nautical or twostroke engines.
- Medium flexibility and quick fixing.
- It fills thickness gaps as far as 6 mm.
- Very good resistance to freezing fluids and oils and to constant temperatures of +312°C and to intermittent temperatures of +350°C.
- Suitable to be used in presence of electronic sensors.
- Applicable on exhaust manifolds, oil pumps, distribution copes, head gaskets in addition to traditional gasket and intake manifolds.
- In compliance with the specific GM/Ford.

Code	Desc.	Cont. g
4030003700	5920	85

## Loctite 5699-29973 (ex Ultra Grey 19250)



- It is a silicone gasket maker with low smell.
- It fills thickness gaps as far as 6 mm.
- It resists freezing fluids and oils and constant temperatures of +205°C and intermittent temperatures of +325°C.
- Suitable to be used in presence of electronic sensors.
- Specific for worked and non worked parts in fusion in general, for water pumps, oil pumps, gear boxes, gear box cover, semistructral joints, rigid parts.

Code	Desc.	Content gr.
4030003800	5699	99

## Adhesive spray Loctite for gaskets 3020-31460 (ex 990)



- It is a spray liquid forming a very sticky film of red colour.
- Useful to keep gaskets in the right position during the assembly.
- Very good as anti-whistle for disk brakes.
- It eliminates the problem of the gap of the pads in their housing without compromising the regular working.
- Used on pulley belts, it carries out an anti-slipping action.
- Resistance to temperature: -50°C +260°C.

Code	Desc.	Cont. ml
4040000100	3020	400

## Loctite gasket remover spray 7200-31037 (ex 8971)



- Innovating product, indispensable to remove in a few minutes traditional and chemical gaskets.
- It melts and eliminates carbonaceous deposits, burnt oil, grease and paint from metal surfaces.
- It doesn't scrape threaded parts.
- It doesn't drip, therefore it can also be used on vertical surfaces.
- Its action develops after AB. 5-10 minutes, avoiding this way the rubbing operation of the pieces, that always causes scratching.

Code	Desc.	Cont. ml
4040000200	7200	400

## Gasket-maker Loctite 5923-18906 (ex 8974)



- It is a slow-drying liquid for strongly close assemblages.
- Used for head and cylinder bloc gaskets, for the assemblage of worked surfaces, of threaded fits, on hydraulic pumps and for the sealing of cooling and heating systems.
- It forms a very flexible brown film.
- Resistance to temperature: -55°C +200°C.
- Complete drying in 24 hours. Operating after 4 hours.

Code	Desc.	Content ml
4040000400	5923	117

## Loctite 5972 18921 high temperature gasket-maker (ex 8979)



- It is a black and viscous pulp, ideal for semipermanent or not rigid assemblages like: flanges, threaded fits and fixing elements.
- Particularly suitable to seal exhaust manifolds and the joints for mufflers for piston or diesel engines or in addition to traditional gaskets.
- The film forming resists oils, hydrocarbons, gasoline, kerosene, ethyl glycol, water, etc.
- Resistance to temperature: -45°C +315°C.
- Resistance to pressure: as far as 340 kg/cm<sup>2</sup>.
- Operating after 3-5 hours.

Code	Desc.	Content gr.
4040000900	5972	200

## Molykote BR2 plus



- Organic-based grease with lithium soaps and mineral based oil.
- Colour: black.
- Of general use, at high characteristics of resistance under heavy charges.
- It reduces friction and wear.
- Particularly used on rolling-contact ball, roller, needle bearings, on joints and driving shafts, on simple supports and guides, mandrels.
- Resistance to temperature: -30°C +130°C.
- Ideal for constant-velocity joints.

Code	Desc.	Content Kg
4080001000	2010	1

## Molykote longterm W2



- It is a white grease of optimum quality, with the additives of solid lubricants.
- Colour: white.
- Resistance to temperature: -30°C +110°C.
- It is put on where a dark grease is not desired, like in the food, textile, paper, household appliances, optical, clothing, pharmaceuticals and hydraulic industry.
- It prevents contact metal/metal and reduces friction and wear.
- To norms mil.G-3278A.

Code	Desc.	Content Kg
4080002900	2033	1



## G-N Plus MoS2 assembly paste



- MoS2 assembly paste for the assembly of mechanical parts that lubricates the parts that are in contact during the first movements in which there is no lubrication.
- Indicated for use during the reassembly of all engines; on the pistons, shells, pins, piston rings, valves and tappets, etc.
- Excellent resistance to strong loads, prevents damage during the running-in period, avoids the risk of engine seizure and jerky movements.
- Operating temperature range: from -25 to +450°C.

Code	Desc.	Content gr.
4080000700	2007	100

## Dow corning 752 (ex Silastic 732 RTV)



- They are sealing single-component adhesives under doughy form, curing by effect of atmospheric humidity in a persistent and solid rubber.
- They resist any outside influence.
- They always keep elastic without shrinking, cracking, crumbling or hardening.
- They resist oils, lubricants and solvents.
- Very good dielectric properties.
- Optimum adhesion on all kinds of materials like: glass, wood, rubber, metal, pottery, technopolymers, natural and synthetical fibres, painted surfaces.
- Used for the sealing of doors, windows, portholes, outside covers of equipments, thread fixing, sealing of cable joints, plugs, switches, winding, substitution of gaskets in engines, carter, gears, hydraulic devices, fixing of plates, mouldings, etc.
- Resistance to temperature: -50°C +220°C.
- Applicable with our guns cod.:

345 00 1540-1160  
 443 00 39800-443P  
 443 00 39810-443professional  
 443 00 39850-443tube.

Code	Description	Content ml
4080002200	2024 black	300
4080002300	2025 white	300
4080002600	2029 transparent	300
4080001400	2014 black	90
4080001500	2015 white	90

## Molykote HSC Plus



- It is a copper pulp containing solid lubricants.
- Color: copper.
- Resistance to temperature: -30°C +1100°C.
- It prevents the contact metal/metal, friction, seizing and overheating.
- Used as lubricant of threaded connections, especially if they are subjected to high temperatures, strong pressures and corrosive atmospheres, on turbines, piston engines, valves, gas generators.
- Optimum also as grease for contacts, having a high electric conductivity.
- Without lead.

Code	Desc.	Content gr.
4080004200	2045	100

## Molykote Separator Spray



- Silicone release agent and lubricant for high performance. lubricates, protects, prevents sticking and helps in molding plastics.
- Used by industries, mechanical, elettrauto and for all maintenance operations.
- Can be used as a release agent in the processing of rubber and plastic in the manufacture of cartons and in woodworking. Ideal for facilitating sliding on conveyor belts in the food industry, it meets the requirements of FDA 21 CFR 178.3570, and and 'registered with nsf category h1 for the contact "accidental" with food.
- It protects over time the plastic and rubber deterioration, prevents sticking, lubricates and protects the seals of all kinds.
- Working temperature: -40 to + 200 ° c.

Code	Desc.	Content ml	Color
4080008200	2084	400	TRANSPARENT

## Molykote 33 light Silicone grease



- Silicone grease, rosecoloured, used in the lubrication of parts in contact on several materials, especially in the combinations metal metal and metal-plastic.
- Particularly suitable in the drive sector, it has a high resistance to oxidation, resistance to water, it has a field of working temperatures going from -73°C to +180°C.
- Before the application on plastic materials, it is important to carry out some tests of swelling and shrinkage to verify the compatibility of the two substances.
- **ATTENTION:** do not mix with other kinds of grease.

Code	Desc.	Formato
4080005500	2058-33L	Tube100g

## Molykote 7 CPD



- It is a special silicone pulp used by honda to remove the problem of the gluing of gaskets of the sunroof with the glass. You put it on the whole rubber gasket and in the back part of the sunroof.
- Particularly used in order to avoid friction among rubbers, plastics, plywood and metals.
- It avoids gluing and wear.

Code	Desc.	Content gr.
4080006500	2068	100

## Meccanocar pressurized sprays



- Pressurized sprays for liquid products, available in two versions:
  - 1 small with capacity 1.000 ml and gun distribution
  - 2 big with capacity 1.800 ml with pressurization and continuous distribution.
- Produced with first-rate materials, resisting to the products of widest consumption. Semitransparent body to see the exact quantity of liquid present inside the viton or gaskets allow the use of these sprays with the most part of technical products sold in drums. In particular, these gaskets have a very good resistance to: mineral oils and greases, hydraulic liquids hardly inflammable of the HFD group, silicone oils and greases, animal and vegetal fats, aliphatic hydrocarbons (for ex. gasoline, butane, propane, methane, etc.), aromatic hydrocarbons (for ex. benzole, toluol),

Code	Desc.	Content ml
4110001201	2003	1.000
4110001205	2004	1.800

Spare Parts		
Code	Content. Parts for dispensing 1.8 liter 411 00 01205-2004	Description
4110001206	Kit with NBR seals, nozzle, filter and non return valve	2004G



## Pressure regulator Heavy Duty



- Pressure regulator professional rugged construction and modern, ideal for the application and use with aggressive technical products such as cleaners, brake, penetrating, solvents, petroleum products.
- Suitable for all applications in every field of work, where they require strength and reliability 'absolute.
- Capacity 'of the product within maximum 1 liter. Container and head reinforced nylon, high pressure seal, inner seals and valves in FPM, regulator adjustable fan jet or needle valve, pressure relief after work.
- Supplied with neutral labels for identification of the product inside.

Code	Desc.	Content ml
4110000310	1002	1.000

Spare Parts		
Code	Content	Description
4110000315	Kit complete with FPM seals nozzle, filter and check valve	1002G
4110000320	Canula of rigid extension	1002C

## Cargo bi-component detergent



ΑΠΟΡΡΥΠΑΝΤΙΚΟ ΔΥΟ ΣΥΣΤΑΤΙΚΩΝ, ΠΟΛΥ ΥΨΗΛΗΣ ΣΥΓΚΕΝΤΡΩΣΗΣ, ΜΕ ΣΥΝΘΕΣΗ ΠΟΥ ΕΧΕΙ ΤΗΝ ΟΨΗ ΔΥΟ ΔΙΑΦΟΡΕΤΙΚΩΝ ΣΤΡΩΜΑΤΩΝ, ΤΟ ΟΠΟΙΟ ΑΝΑΚΙΝΕΙΤΑΙ ΠΡΙΝ ΑΠΟ ΤΗ ΧΡΗΣΗ, ΚΑΙ ΤΟ ΜΙΓΜΑ ΠΟΥ ΑΝΑΚΥΠΤΕΙ ΕΧΕΙ ΑΠΙΣΤΕΥΤΑ ΑΠΟΤΕΛΕΣΜΑΤΙΚΗ ΚΑΘΑΡΙΣΤΙΚΗ ΔΡΑΣΗ. ΚΑΤΑΛΛΗΛΟ ΓΙΑ ΤΟ ΒΑΘΥ ΚΑΘΑΡΙΣΜΟ ΣΚΑΦΩΝ - ΦΟΡΤΗΓΩΝ - ΜΟΥΣΑΜΑΔΩΝ - ΑΥΤΟΚΙΝΗΤΩΝ - ΜΗΧΑΝΩΝ - ΕΞΑΡΤΗΜΑΤΩΝ - ΔΕΞΑΜΕΝΩΝ ΚΑΘΩΣ ΚΑΙ ΓΙΑ ΤΗΝ ΕΞΑΛΕΙΨΗ ΚΑΘΕ ΕΙΔΟΥΣ ΕΠΙΜΟΝΟΥ ΛΕΚΕ. ΔΕΝ ΚΑΤΑΣΤΡΕΦΕΙ ΤΑ ΧΡΩΜΑΤΑ, ΤΑ ΠΛΑΣΤΙΚΑ ΥΛΙΚΑ, ΤΑ ΕΛΑΣΤΙΚΑ, ΤΗΝ ΕΠΙΣΤΡΩΣΗ ΧΡΩΜΙΟΥ Κ.Τ.Λ. ΒΙΟΔΙΑΣΠΩΜΕΝΟ ΠΡΟΪΟΝ ΣΕ ΠΟΣΟΣΤΟ ΑΝΩ ΤΟΥ 90%. ΑΝΑΚΙΝΗΣΤΕ ΚΑΛΑ ΠΡΙΝ ΑΠΟ ΤΗ ΧΡΗΣΗ, ΑΡΑΙΩΣΤΕ ΤΟ ΜΕ ΝΕΡΟ ΣΕ ΑΝΑΛΟΓΙΑ 1:40, 1:50, ΨΕΚΑΣΤΕ ΣΕ ΣΤΕΓΝΕΣ ΕΠΙΦΑΝΕΙΕΣ ΚΑΙ ΜΕΤΑ ΞΕΠΛΥΝΕΤΕ ΜΕ ΠΙΕΣΤΙΚΟ. ΔΕΝ ΧΡΕΙΑΖΕΤΑΙ ΒΟΥΡΤΣΙΣΜΑ. ΑΝ Η ΕΠΙΦΑΝΕΙΑ ΕΧΕΙ ΥΠΕΡΘΕΡΜΑΝΘΕΙ, ΚΑΛΟ ΕΙΝΑΙ ΝΑ ΤΗΝ ΑΦΗΣΕΤΕ ΝΑ ΚΡΥΩΣΕΙ ΠΡΙΝ ΧΡΗΣΙΜΟΠΟΙΗΣΕΤΕ ΤΟ ΠΡΟΪΟΝ. 5LT

Code	Description	Content KG
4110016410		5
4110016510		20

## Spray cans rechargeable metal-pressurizable



Code	Desc.	Cont. max	Corpo bombola	Dimensions h x Ø mm	Weight gr.
4110000350	1004	650 ml	Aluminum	280 x 65	190
4110000360	1005	650 ml	Stainless steel	270 x 70	435

Spare Parts		
Article	Code	Desc.
Dispensing button fold extension	4110000370	1006
Compressed air charging valve	4110000380	1007

- Cylinders spray refillable, pressurizable through common compressed air, suitable for the environmentally friendly use of liquid chemical products of all kinds, lubricants, penetrating oils, detergents, solvents, or just to blow, with button with metallic extension.
- Suitable for use in all workshops of any kind. Avoid the expense of classical spray, being able to use the active substance at 100% and avoiding solvents, also avoid the cost of disposal of exhausted aerosols, allowing a huge money saver. Facilitate the storage of the material avoiding the need to keep a large number of spray bottles in warehouses.
- Completely made in metal of two types: aluminum lined or stainless steel. The aluminum cylinders are recommended for use with solvent-based products such as unlocking, degrippanti, lavamotori, parts washer, brake cleaners, etc. The stainless steel tanks are particularly suitable for aggressive cleaning products such as two-component, lavateloni, lavacerchi, remove insects, usually water-based detergents.
- Extremely safe and reliable, have special seals impervious to all chemicals even aggressive, they load Max with 650 ml of liquid product (About 2/3 of the bottle) and put under pressure by a common inflator to the maximum pressure of 6.3 bar. In the event of excess pressure a safety valve discharges the excess air to ensure the safety.
- They work in all positions, even upside down. Straight Key has a fan jet, while raising the extension of steel you get a very precise needle jet and the long-range.
- Supplied with labels to write on the product contained within.

## Nebuliser



- Container with trolley.
- With spiral and head with adjustable nozzle.
- Permits nebulisation of detergents poured into tank.
- With funnel for ease of filling.
- Capacity 24 lt.

Code	Desc.	Characteristics
4430045610	599	NEBULISER

Spare Parts		
Code	Desc.	Features
4430045611	599/1	sprayer replacement
4430045612	599/2	nozzle for sprayer
4430045613	599/3	spiral with fittings
4700004813	2588RF	fixed wheel
345RC03770	377	monometer replacement Ø 63 CEE
1760028070	6630 10-1/4	junction at "L" 1/4 for tubes 8X10

## Nebulizer stainless steel



- Nebulizer trolley with filling funnel and gauge constructed entirely of stainless steel. Shown to contain corrosive liquids and corrosive, impossible to use with classic nebulizers iron.
- Use by anyone for spray cleaning liquids also basic or acidic, absence of formation of rust even if they are left inside the liquids used for a long time.
- Tank capacity of 24 liters, equipped with pressure gauge domestic steel lance with shockproof handle, quick series Italy to commission pressure, support the launch with the collection cup drips.
- size; A: 310 mm. B: 370 mm. C: 805 mm. Weight 13 kg.

Code	Desc.
4430056955	1804

Spare Parts		
Article	Code	Desc.
Spear parts (complete with nozzle)	4430045611	599/1
Spare nozzle for lance	4430045612	599/2
Spiral with fittings	4430045613	599/3
Spare wheel	4700004813	2588RF

## Cartridge gun type silicon



- Technical features section Equipment Manual - Specific equipment for bodywork and workshop

Code
4430039810-443

## Cartridge gun type silicone bags and 400 ml



- Technical features section Equipment Manual - Specific equipment for bodywork and workshop

Code
4430039850-443

## Cartridge gun type silicon



- Technical features section Equipment Manual - Specific equipment for bodywork and workshop

Code
4430039800-443P

## Caulking gun cartridges



- Technical features section Tools electric and pneumatic - Pneumatic tools

Code
3450001540-1160

## Mastic gun spraying and tang



- Technical features section Tools electric and pneumatic - Pneumatic tools

Code
3450003919-6006

## Cartridge gun-component 50ml



- Gun universal for any type of two-component cartridge 50 ml.
- The thrust mechanism completely in steel and the construction in reinforced nylon fiber glass give the product a particular impact resistance, wear and a considerable capacity 'thrust making the operator's work easier.



Particolare del  
meccanismo  
di spinta

Code	Desc.
3450010770	310

## Pistola manuale per sigillanti in sacchetto 600 ml



- Pistola manuale professionale per l'applicazione di sigillanti in sacchetto con capacità fino a 600 ml. Costruita appositamente per l'estrusione anche di prodotti ad alta viscosità.
- Indicata per tutti i settori lavorativi: autocarrozzerie, trasformazione di veicoli, costruzione e posa infissi, carpenterie industriali, ecc.
- Impugnatura rivestita antiscivolo, frizione ed asta di spinta in acciaio temprato, tubo e ghiera di chiusura in alluminio. Rapporto di spinta 18:1.
- Peso: 1,17 Kg.

Code	Desc.
4430039880	443/600



## Pneumatic gun for sealants in bag 600ml



- Pneumatic gun with large thrust force for the application of each type of silicone sealant in 600 ml bags, with adjustment of the pressure and of the sealant output speed..
- Robust and reliable tool suitable for use in all machining areas that provides the application of sealants of all types: body shops, transformation means, construction and installation of fixtures, plumbing, carpentry, construction in general, etc..
- Built entirely of aluminum, including closure ring nuts, operation with internal piston thrust, comfortable and balanced central grip, microcontroller pressure for the speed adjustment.
- The machine has a discharge valve to prevent the leakage of sealant, at the end of the use. It can work with any type of bag of diameter 50-51 mm in length and up to a maximum of 335 mm. Uses standard extrusion nozzles supplied with bags.

Code	Desc.
3450010830	312

Tecnical Features	
Lunghezza tubo corpo macchina	400 mm
Db (A)	<80 dBA
Weight	1,3 Kg
Air inlet thread	1/4" gas male
Pressione di lavoro	4 - 8 bar
Massima forza di spinta (@ 8 bar)	160 Kgf - 1569 N

## Gun battery sealant 310-400 ml 3.6V-1.5Ah



- Technical features section Tools electric and pneumatic - Electric Tools

Code
4170020070-EY3610-LA1J

## Gun battery sealant 310-600 ml 14,4V-4,2Ah



- Technical features section Tools electric and pneumatic - Electric Tools

Code
4170020080-EY3641-LS1S

## Gun battery sealant 290-310 ml 14,4V-4,2Ah



- Technical features section Tools electric and pneumatic - Electric Tools

Code
4170020090-EY3640-LS1S

## Straight nozzle for sealants



- Straight exchange nozzle for plastic cartridges.
- Can be easily cut to conform to any diameter and shape.

Code	Desc.
4110017270	4300D

## Nozzle for sealants V-shaped for glass



- V-shaped nozzle and support bar for the application of glues on glass.
- Suitable for plastic cartridges.

Code	Desc.
4110017280	4300V

## Spray sealant nozzle



- Wide-base nozzle for the application of ms polymer polyurethane spray sealants, such as our art. 411 00 15000-2812.
- Can be used as a replacement for our pneumatic gun code 345 00 03919-6006.

Code	Desc.
4110017290	4300S

## Flat beading nozzle for sealants



- Universal nozzle with wings; can be cut easily and suitable for plastic cartridges.
- The support that is created using the wings help the operator to recreate a beading that is the same as the original.
- Cut the nozzle on the basis of the piece to be sealed. Bend the wing to create the support for the support.
- Extrude the sealant.

Code	Desc.
4110017300	4300A

## Adapter for sealants in bag



- Adapter applicable on guns for extruding sealants in bags (see our codes 4430039850, 3450003919, 4170008600).
- There it can 'screw on the nozzle can be rotated 360 ° cod 411 00 19260, the tube extension cod 411 00 19265, the spout right code 4110017270 and the nozzle plate to curb 4,110,017,300.
- Used worldwide in all sectors of employment and where 'necessary to apply silicones and sealants: bodywork, construction, window fitters, heating and plumbing.
- Reclosable cap cod. 4110019275 to prevent air, dust and dirt from damaging the material inside the cartridge. Hood sold separately.

Code	Desc.	Article	Length mm
4110019270	5905AD	Adapter for sealants in bag	109

## Dust cap



- Screw-on the adapter for sealants in bag cod 4110019270, and all cartridges in plastic.
- Ideal for storage of all types of sealants and silicones after use. Prevents air, dust and dirt from damaging the cartridge and will deteriorate the product.

Code	Desc.	Article
4110019275	5910C	Dust cap







## Metallic hardware and screw

Bolts and nuts . . . . .	pag. 170	Rivets, threaded inserts, tools for rivet . . . . .	pag. 235
Grub screws, threaded rods, studs . . . . .	pag. 189	Plastic and metal hose clamp . . . . .	pag. 249
Washers . . . . .	pag. 193	Oil sump plugs . . . . .	pag. 266
Self-drilling and self-tapping screws . . . . .	pag. 203	Traction springs. . . . .	pag. 269
Hooks, eye bolts, generic fasteners, seals and . . . . .	pag. 222	Threads filemecc, self tapping bushings . . . . .	pag. 272

## Hex head screws Din 931 Uni 5737



- Class 8.8 steel.
- ISO metric.
- Coarse - MA.
- Partially threaded.

Code	Material type
12300****-5737	STEEL BRUNISHED 8.8
12600****-5737	GALVANIZED WHITE 8.8

\*\*\*\* sizes: see price list

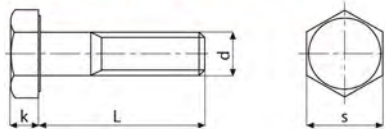

d	4x0,7	5x0,8	6x1	7x1	8x1,25	10x1,5	12x1,75	14x2	16x2	18x2,5	20x2,5	22x2,5	24x3	27x3	30x3,5
s=key	7	8	10	11	13	17	19	22	24	27	30	32	36	41	46
k	2,8	3,5	4	4,8	5,3	6,4	7,5	8,8	10	11,5	12,5	14	15	17	18,7

## Viti testa esagonale Uni 5739 Din 933



- Classe di resistenza 8.8 acciaio
- Filettatura metrica iso
- Passo grosso - MA
- Filetto totale

Code	Material type
12300****-5739	ACCIAIO BRUNITO 8.8
12600****-5739	ACCIAIO ZINCATO BIANCO 8.8

\*\*\*\* sizes: see price list

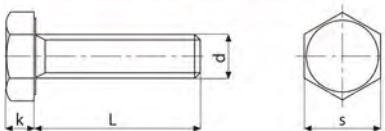

d	4x0,7	5x0,8	6x1	7x1	8x1,25	10x1,5	12x1,75	14x2	16x2	18x2,5	20x2,5	22x2,5	24x3	27x3	30x3,5
s=key	7	8	10	11	13	17	19	22	24	27	30	32	36	41	46
k	2,8	3,5	4	4,8	5,3	6,4	7,5	8,8	10	11,5	12,5	14	15	17	18,7

## Hex head screws Din 960 Uni 5738



- Class 8.8 steel.
- ISO metric.
- Fine pitch - MB.
- Partially threaded.

Code	Material type
12300****-5738	STEEL BRUNISHED 8.8
12600****-5738	GALVANISED STEEL WHITE 8.8

\*\*\*\* sizes: see price list

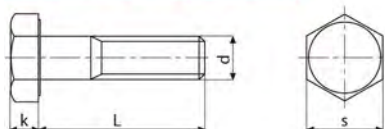

d	8x1	10x1,25	12x1,25	12x1,5	14x1,5	16x1,5	18x1,5	20x1,5	22x1,5	24x2
s=key	13	17	19	19	22	24	27	30	32	36
k	5,3	6,4	7,5	7,5	8,8	10	11,5	12,5	14	15

## Hex head screws Din 961 Uni 5740



- Class 8.8 Steel
- ISO metric thread
- Fine pitch - MB
- total thread

Code	Material type
12300****-5740	STEEL BRUNISHED 8.8
12600****-5740	GALVANISED STEEL WHITE 8.8

\*\*\*\* sizes: see price list

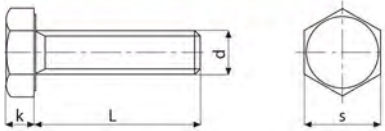

d	8x1	10x1,25	12x1,25	12x1,5	14x1,5	16x1,5	18x1,5	20x1,5	22x1,5	24x2
s=key	13	17	19	19	22	24	27	30	32	36
k	5,3	6,4	7,5	7,5	8,8	10	11,5	12,5	14	15

## Hexagon head screws High Strength



- Class 10.9 steel.
- ISO metric.
- Coarse - MA.
- Fillet partial and total.

Code	Material type
12400****	STEEL BRUNISHED 10.9

\*\*\*\* sizes: see price list

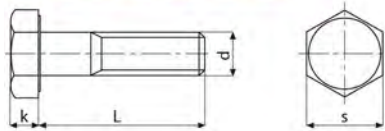

d	4x0,7	5x0,8	6x1	7x1	8x1,25	10x1,5	12x1,75	14x2	16x2	18x2,5	20x2,5	22x2,5	24x3	27x3	30x3,5
s=key	7	8	10	11	13	17	19	22	24	27	30	32	36	41	46
k	2,8	3,5	4	4,8	5,3	6,4	7,5	8,8	10	11,5	12,5	14	15	17	18,7

## Hex head screws UNF (fine pitch)



- Class 8.8.
- ANSI B 18.2.1.
- UNF thread (fine pitch).

Code	Material type
13100****	STEEL BRUNISHED 8.8

\*\*\*\* sizes: see price list

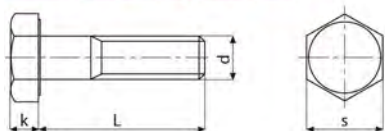

d x fil. x inch	1/4-28	5/16-24	3/8-24	7/16-20	1/2-20	9/16-18	5/8-18	3/4-16
s=key	7/16 11,11	1/2 12,7	9/16 14,28	5/8 15,87	3/4 19,5	13/16 20,63	15/16 23,81	1-1/8 28,57
k	5/32 3,97	13/64 5,16	15/64 5,95	9/32 7,14	5/16 7,94	23/64 9,13	25/64 9,92	15,32 11,91



## Hex head screws in inches UNC (coarse pitch)



- Class 8.8.
- ANSI B 18.2.1.
- UNC thread (coarse pitch).

Code	Material type
13200*****	STEEL BRUNISHED 8.8

\*\*\*\*\* sizes: see price list

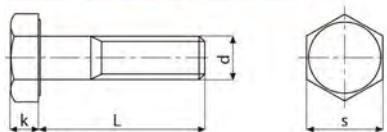

d x fl. x inch	1/4-20	5/16-18	3/8-16	7/16-14	1/2-13	9/16-12	5/8-11	3/4-10	7/8-9	1-8
s=key	7/16 11,11	1/2 12,7	9/16 14,28	5/8 15,87	3/4 19,5	13/16 20,63	15/16 23,81	1-1/8 28,57	1-5/16 33,33	1-1/2 38,1
k	5/32 3,97	13/64 5,16	15/64 5,95	9/32 7,14	5/16 7,94	23/64 9,13	25/64 9,92	15,32 11,91	35/64 13,89	39/64 15,48

## Hex head screws Din 931 Uni 5737 Steel A2



- Strength class stainless steel.
- Coarse - MA.
- Partially threaded.

Code	Material type
14400*****-5737	STAINLESS STEEL A2 - AISI 304

\*\*\*\*\* sizes: see price list

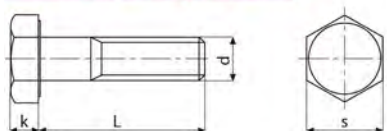

d	4x0,7	5x0,8	6x1	8x1,25	10x1,5	12x1,75	14x2	16x2	18x2,5	20x2,5	22x2,5	24x3	27x3	30x3,5
s=key	7	8	10	13	17	19	22	24	27	30	32	36	41	46
k	2,8	3,5	4	5,3	6,4	7,5	8,8	10	11,5	12,5	14	15	17	18,7

## Hex head screws Din 933 Uni 5739 Steel A2



- Strength class stainless steel.
- Coarse - MA.
- Total thread.

Code	Material type
14400*****-5739	STAINLESS STEEL A2 - AISI 304

\*\*\*\*\* sizes: see price list

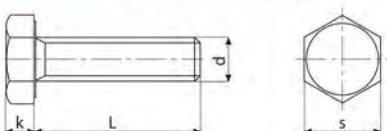

d	4x0,7	5x0,8	6x1	8x1,25	10x1,5	12x1,75	14x2	16x2	18x2,5	20x2,5	22x2,5	24x3	27x3	30x3,5
s=key	7	8	10	13	17	19	22	24	27	30	32	36	41	46
k	2,8	3,5	4	5,3	6,4	7,5	8,8	10	11,5	12,5	14	15	17	18,7



## Hexagon head screws steel A4



- Strength class: A4 stainless steel AISI 316.
- Coarse - MA.
- UNI 5739 DIN 933. Fillet total.
- UNI 5737 DIN 931. Thread partial.

Code	Material type
144A4****	STAINLESS STEEL A4 - AISI 316

\*\*\*\* sizes: see price list

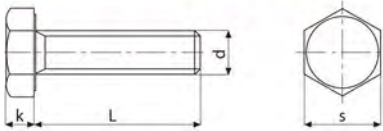

d	5x0,8	6x1	8x1,25	10x1,5	12x1,75	14x2	16x2	18x2,5	20x2,5
s=key	8	10	13	17	19	22	24	27	30
k	3,5	4	5,3	6,4	7,5	8,8	10	11,5	12,5

## Assortment bolts burnished 36 boxes



- Content: Bolts 6x16 to 6x60; bolts from 8x16 to 8x50 step 1.25; bolts from 10x16 to 10x60 step 1.25; bolts from 12x20 to 12x60 step 1.25; nuts from dia. 6 in diam. 12; flat washers diam. 6 in diam. 12; spring washers diam. 6 in diam. 12.
- Total 1560 pieces
- Supplied in metal shelf n / s cod. 433 00 39 200 435
- Size mm. 600 x 600 x 12

### Content kit

CODE	DESCRIPTION	PCS
1230002800	6X16	100
1230002900	6X20	100
1230003200	6X30	50
1230003400	6X40	50
1230003800	6X50	10
1230003800	6X60	10
1230005500	8X16X1,25	50
1230005700	8X25X1,25	50
1230005900	8X30X1,25	50
1230005900	8X35X1,25	50
1230006000	8X40X1,25	20
1230006200	8X50X1,25	10
1230006400	10X16X1,25	20
1230006800	10X25X1,25	20
1230006700	10X30X1,25	20
1230006900	10X40X1,25	10
1230009100	10X50X1,25	5
1230009300	10X60X1,25	5

CODE	DESCRIPTION	PCS
1230012200	12X20X1,25	10
1230012400	12X30X1,25	10
1230012500	12X35X1,25	10
1230012550	12X40X1,25	5
1230012800	12X50X1,25	5
1230013100	12X65X1,25	5
2070000400	6	100
2070000700	8X1,25	100
2070001000	10X1,25	50
2070001200	12X1,25	50
2440000400	6	60
2440000600	8	100
2440000700	10	50
2440000800	12	50
2660000300	6	100
2660000500	8	100
2660000700	10	50
2660000800	12	50
4430009200	435	1

Code	Desc.
1230100100	13790

## Assortment galvanized bolts 36 boxes

2



- Content: Bolts galvanized 6x16 to 6x60; galvanized bolts from 8x16 to 8x50 step 1.25; galvanized bolts from 10x16 to 10x60 step 1.5; galvanized bolts from 12x20 to 12x60 step 1,75; galvanized nuts from dia. 6 in diam. 12; galvanized flat washers diam. 6 in diam. 12; spring washers galvanized diam. 6 in diam. 12.
- Total 1585 pieces
- Supplied in metal shelf n / s cod. 443 00 39200 435.
- Size mm. 600 x 600 x 12

**Content kit**

CODE	DESCRIPTION	PCS	CODE	DESCRIPTION	PCS
1260001200	6X16	100	1260005500	12X20X1,75	10
1260001300	6X20	100	1260005600	12X30X1,75	10
1260001500	6X30	50	1260005700	12X35X1,75	5
1260001600	6X35	20	1260005800	12X40X1,75	10
1260001900	6X50	20	1260005900	12X50X1,75	5
1260001920	6X60	10	1260005910	12X60X1,75	5
1260002800	8X16X1,25	50	2080000300	6	100
1260002800	8X25X1,25	50	2080000500	8X1,25	100
1260002900	8X30X1,25	50	2080000700	10X1,5	50
1260003000	8X35X1,25	50	2080001000	12X1,75	50
1260003100	8X40X1,25	25	2450000300	6	150
1260003300	8X50X1,25	20	2450000600	8	100
1260004418	10X16X1,5	20	2450000800	10	50
1260004425	10X25X1,5	20	2450000700	12	50
1260004430	10X30X1,5	20	2670000250	6	150
1260004437	10X40X1,5	10	2670000300	8	100
1260004443	10X50X1,5	5	2670000350	10	50
1260004550	10X60X1,5	5	2670000400	12	50
			4430039200	435	1

Code	Desc.
1260100100	36

## Kit minuteria A4



- Assortment of A4 size stainless steel parts
- Suitable for all types of customers
- Supplied in a practical plastic case our code 3980001900
- Total: 725 pieces with briefcase

**Content kit**

CODE	DESCRIPTION	PCS
144 A4 00800	5X20	50
144 A4 01000	5X30	50
144 A4 01600	6X20	50
144 A4 01700	6X25	50
144 A4 01800	6X30	50
144 A4 02000	6X40	25
144 A4 02400	8X20X1,25	25
144 A4 02500	8X25X1,25	25
144 A4 02800	8X40X1,25	20
144 A4 04300	10X60X1,5	5
209 A4 00300	5	50
209 A4 00400	6	50
209 A4 00500	8X1,25	50
209 A4 00600	10X1,5	25
247 A4 00300	5	50
247 A4 00400	6	50
247 A4 00500	8	50
247 A4 00600	10	50

Code	Description
144A413000	1-kit minuteria A4

## Screws T.P.S. with internal hexagon



- UNI 5933.
- DIN 7991-A.
- ISO metric.
- Class 10.9.

Code	Material type
13700*****	BRUNISHED STEEL
137A2*****	STAINLESS STEEL A2
137ZN*****	GALVANIZED WHITE

\*\*\*\*\* sizes: see price list

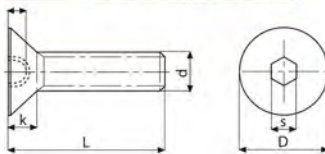

d	3x0,5	4x0,7	5x0,9	6x1	8x1,25	10x1,5	12x1,75	14x2	16x2	18x2,5	20x2,5
D	6	8	10	12	16	20	24	27	30	33	36
k	1,7	2,3	2,8	3,3	4,4	5,5	6,5	7	7,5	8	8,5
s=key	2	2,5	3	4	5	6	8	10	10	12	12

## Button head bolts screws with hexagon socket DIN flange 267



- Class 10.9.
- ISO metric.

Code	Material type
12200*****	STEEL BRUNISHED
122A2*****	STAINLESS STEEL A2

\*\*\*\*\* MISURE: VEDI LISTINO

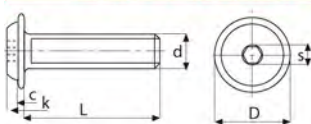

d	M 4x0,7	M 5x0,8	M 6x1	M 8x1,25	M 10x1,5
D max	9,4	11,8	13,6	17,8	21,9
k max	2,2	2,75	3,3	4,4	5,5
c min	0,9	1	1,1	1,2	1,5
s=key	2,5	3	4	5	6

## Button head bolts screws with internal hexagon DIN 7380



- Class 10.9.
- Metric thread DIN 7380.
- In white galvanized steel.

Code	Material type
134ZN*****	GALVANIZED WHITE

\*\*\*\*\* sizes: see price list

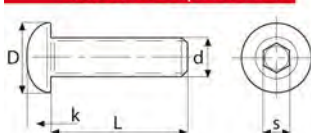

d	M 4x0,7	M 5x0,8	M 6x1	M 8x1,25	M 10x1,5	M 12x1,75
D max	7,6	9,5	10,5	14	17,5	21
k max	2,2	2,75	3,3	4,4	5,5	6,6
s=key	2,5	3	4	5	6	8

## Hex head screws Flanged and serrated under head DIN 6921



- Metric screws with hexagonal head class 8.8 galvanized white with knurled flange under head. Coarse MA.
- These screws are suitable for clamping of parts with dynamic loads they incorporate the system lock to prevent loosening.
- They are generally used in combination with flanged nuts and knurled our family 293 00 items.

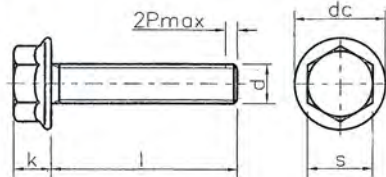

Code	Desc. dxL	K mm	s mm	dc mm
126TF00010	5x10	5,0	8	11,0
126TF00020	5x12	5,0	8	11,0
126TF00030	5x16	5,0	8	11,0
126TF00060	6x10	6,5	10	13,5
126TF00070	6x12	6,5	10	13,5
126TF00080	6x16	6,5	10	13,5
126TF00090	6x20	6,5	10	13,5
126TF00140	8x16	7,5	13	17,0
126TF00150	8x20	7,5	13	17,00
123TF00160	8x25	7,5	13	17,0
126TF00220	10x20	9,0	17	21,0
126TF00230	10x25	9,0	17	21,0
126TF00240	10x30	9,0	17	21,0
126TF00270	12x25	10,5	19	24,5
126TF00280	12x30	10,5	19	24,5
126TF00290	12x35	10,5	19	24,5

## Head screws with hexagon socket UNI 5931 DIN 912



- Class 8.8 steel.
- ISO metric.
- Coarse - MA.

Code	Material type
13800*****	STEEL BRUNISHED 8.8
13900*****	GALVANIZED WHITE 8.8
14300*****	STAINLESS STEEL A2

\*\*\*\* MISURE: VEDI LISTINO

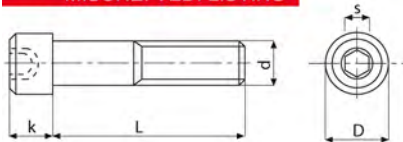

d	4x0,7	5x0,8	6x1	8x1,25	10x1,5	12x1,75	14x2	16x2	16x2,5	20x2,5	24x3
D	7	8,5	10	13	16	18	21	24	27	30	36
k	4	5	6	8	10	12	14	16	18	20	24
s=chiave	3	4	5	6	8	10	12	14	14	17	19



## Screws Round head square neck galvanized - steel A2



- Strength class: 4.6.
- Coarse - MA.
- UNI 5732.
- Partially threaded.
- A2 stainless steel supplied without nut.

Code	Material type
18200*****	GALVANISED STEEL WHITE
182A2*****	STAINLESS STEEL A2

\*\*\*\*\* sizes: see price list

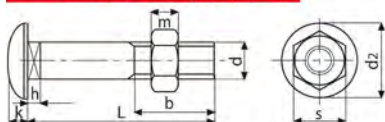

d	M 5	M 6	M 8	M 10	M 12
d <sub>2</sub>	13	15,5	20	25	30
k	2,5	3	4	5	6
h	3,5	4	5	6	8
s=key	8	10	13	17	19
m	4	5	6,5	8	10
b/mm	16-20	18/23	22-28	26-33	30-38

## Metric screws



- The round-head screws low - thanks to the smaller dimensions of the head - are also used in securing the holder to the body.

\*\*\*\*\* MISURE: VEDI LISTINO

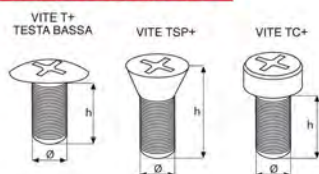

Code	Material type
11200*****	VITE T+ FERRO ZINCATA
11800*****	VITE TC+ FERRO ZINCATA
12000*****	VITE TSP+ FERRO ZINCATA
118A2*****	VITE TC+ ACCIAIO INOX A2
120A2*****	VITE TPS+ ACCIAIO INOX A2

## Assortment metric screws cylindrical head galvanized



- Contents: 16 screw sizes tc + galvanized from 4x16 to 4x40, from 5x10 to 5x50, from 6x10 to 6x50 + 8x25 + 8x30
- Total 900 pieces
- Supplied in a plastic carrying case n / s cod. 398 00 01900 abh4

Code	Desc.
1180100100	16

### Content kit

CODE	DESCRIPTION	PCS
118 00 00100	4X16	100
118 00 00200	4X20	100
118 00 00500	4X35	100
118 00 00600	4X40	50
118 00 00700	5X10	100
118 00 00900	5X20	50
118 00 01300	5X40	50
118 00 01500	5X50	25
118 00 01600	6X10	50
118 00 01700	6X16	50
118 00 01800	6X20	50
118 00 02000	6X30	50
118 00 02400	6X50	25
118 00 02500	8X25	25
118 00 02600	8X30	25
118 00 01100	5X30	50

## Assortment metric screws flat head galvanized



- Contents: 16 measures galvanized screws tps + from 4x16 to 4x40, 5x10 to 5x50, 6x10 to 6x50 to 8x20 + 8x30 +
- Total 900 pieces
- Supplied in a plastic carrying case n / s cod. 398 00 01900 abh4

Code	Desc.
1200100100	16

### Content kit

CODE	DESCRIPTION	PCS
120 00 00100	4X16	100
120 00 00200	4X20	100
120 00 00400	4X30	100
120 00 00600	4X40	50
120 00 00700	5X10	100
120 00 00900	5X20	50
120 00 01100	5X30	50
120 00 01300	5X40	50
120 00 01500	5X50	25
120 00 01700	6X10	50
120 00 01750	6X16	50
120 00 01800	6X20	50
120 00 02000	6X30	50
120 00 02450	8X20	25
120 00 02600	8X30	25

## Nuts stainless A2 threaded hole in the head detachable



- Nuts steel fasteners to thread through.
- Ideal for applications with screws ttdc our code. 182 00 \* 182 \* a2 for the realization of fastenings inviolable.

Code	Desc.	Thread	L mm	Wrench mm
1550002650	19/1-M8	8x1,25	8x1,25	17
1550002660	19/2 - M10	10x1,5	10x1,5	19

## Nuts stainless A2 M8 head detachable



- Blind nut steel fasteners.
- Ideal for applications with screws ttdc our code. 182 00 \* 182 \* a2 for the realization of fastenings inviolable.



Code	Description	Step	Ø 1 mm	Ø 2 mm	L mm	Wrench mm
1550002680	19/5 - flared	8x1,25	10	14,5	4	15
1550002690	19/6	8x1,25	12	14,5	6	15
1550002700	19/7	8x1,25	10	14,5	6	15

## Hex nuts raw

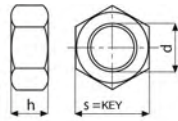

Code	Desc. d x pace	UNI	h mm	s key
2070G00060	5	5587	5	8
2070G00100	6	5587	6	10
2070G00200	8x1,25	5587	8	13
2070G00400	10x1,5	5588	8	17
2070G00500	10x1,5	5587	10	17
2070G00505	12x1,25*	5587	12	19
2070G00520	12x1,75	5587	12	19
2070G00525	12x1,75	5588	10	19
2070G00545	14x1,5*	5587	14	22
2070G00550	14x2	5587	14	22
2070G00560	14x2	5588	11	22
2070G00600	16x2	5587	16	24
2070G00620	16x2	5588	13	24
2070G00800	18x1,5*	5587	18	27
2070G00900	18x2,5	5587	18	27
2070G01000	20x1,5*	5587	20	30

- Strength class: 6s (Class 8)
- Type of material: Raw steel

## Hex nuts burnished

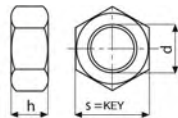

Code	Desc. d x pace	h mm	s key
2070000100	3	3	5,5
2070000200	4	4	7
2070000300	5	5	8
2070000400	6	6	10
2070000500	7	7	11
2070000600	8x1*	8	13
2070000700	8x1,25	8	13
2070001000	10x1,25*	10	17
2070001100	10x1,5	10	17
2070001200	12x1,25*	12	19
2070001300	12x1,5*	12	19
2070001400	12x1,75	12	19
2070001600	14x1,5*	14	22
2070001700	14x2	14	22
2070001800	16x1,5*	16	24
2070001900	16x2	16	24
2070002000	18x1,5*	18	27
2070002100	18x2,5	18	27
2070002200	20x1,5*	20	30
2070002300	20x2,5	20	30
2070002400	22x1,5*	22	32
2070002600	22x2,5	22	32
2070002700	24x2*	24	36
2070002720	24x3	24	36
2070002740	27x2*	27	41
2070002800	30x3,5	30	46

- Strength class: 6s (Class 8)
- UNI 5587



## Hex nuts burnished high resistance

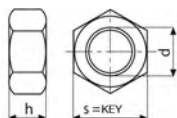

- Strength class: 8 g (Class 10)

Code	Desc. d x pace	h mm	s key
2070000705	8x1,25	8	13
2070001105	10x1,5	10	17
2070001405	12x1,75	12	19
2070001750	14x2	14	22

2

## Hex nuts Brass

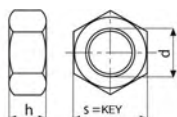

Code	Desc. d x pace	h mm	s key
2060000200	5	4	8
2060000300	6	6	10
2060000500	8x1*	6,5	13
2060000600	8x1,25	6,5	13
2060000700	8x1,25	8	13
2060000800	8x1,25	10	13
2060001100	10x1,25*	10	17
2060001400	10x1,5	10	17
2060001600	12x1,5*	10	19

- Type of material: Brass OT 58
- Resist. Heat: Up to 250 ° C

## Hex nut galvanized white bass

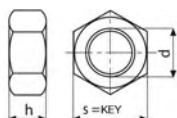

- Steel material class 6S
- UNI 5589

Code	Desc. d x pace	H mm	s key
2080000325	6x1	4	10
2080000610	8x1,25	5	13
2080000845	10x1,5	6	17
2080001610	12x1,75	7	19
2080001620	14x2	8	22
2080001232	16x1,5*	8	24
2080001241	16x2	8	24

## Medium hex nuts galvanized

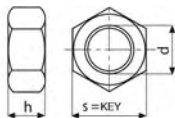

Code	Desc. d x pace	Measures h	Measures s
2080000050	3	2,4	5,5
2080000100	4	3,2	7
2080000200	5	4	8
2080000300	6	5	10
2080000350	7	5,5	11
2080000400	8x1*	6,5	13
2080000500	8x1,25	6,5	13
2080000700	10x1,5	8	17
2080000800	10x1,25*	8	17
2080000860	12x1,5	10	19
2080000900	12x1,25*	10	19
2080001000	12x1,75	10	19
2080001100	14x1,5*	11	22
2080001200	14x2	11	22
2080001230	16x1,5*	13	24
2080001240	16x2	13	24
2080001260	18x2,5	15	27
2080001280	20x1,5*	16	30
2080001285	20x2,5	16	30
2080001290	22x2,5	18	32
2080001300	24x3	19	36
2080001400	27x3	22	41

- Class resist. : 6S.
- UNI 5588.

## High galvanized white hexagonal nuts

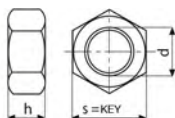

- Steel material class 6s
- Galvanized finish white
- UNI 5587

Code	Desc.	s key	FIL. XL.	h
2080000320	M6X1	10	6X6	6
2080000600	M8X1.25	13	8X8	8
2080000840	M10X1.5	17	10X10	10
2080001050	M12X1.75	19	12X12	12

## Assortment galvanized nuts



- Contents: 8 measures of galvanized nuts UNI 5588 coarse-but from diam. 4 to diam. 14
- Total 1225 pieces
- Supplied in a plastic carrying case n / s cod. 398 00 01900 abh4

Code	Desc.
2080100100	8

### Content kit

CODE	DESCRIPTION	PCS
208 00 00100	4	400
208 00 00200	5	200
120 00 01700	6	200
120 00 01750	8X1.25	100
120 00 01800	10X1.5	50
120 00 02000	14X2	50
120 00 02450	16X2	25
120 00 02600	12X1.75	25

## Hex nuts stainless

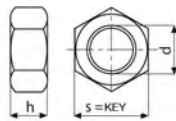

- UNI 5588

DESCR.	MEASURES		STAINLESS STEEL	STAINLESS STEEL
	h	s	A2 - AISI 304	A4 - AISI 316
dxstep			<b>CODE</b>	<b>CODE</b>
<b>3</b>	2,4	5,5	<b>209 00 00100</b>	
<b>4</b>	3,2	7	<b>209 00 00200</b>	
<b>5</b>	4	8	<b>209 00 00300</b>	<b>209 A4 00300</b>
<b>6</b>	5	10	<b>209 00 00400</b>	<b>209 A4 00400</b>
<b>8x1,25</b>	6,5	13	<b>209 00 00500</b>	<b>209 A4 00500</b>
<b>10x1,5</b>	8	17	<b>209 00 00600</b>	<b>209 A4 00600</b>
<b>12x1,75</b>	10	19	<b>209 00 00700</b>	<b>209 A4 00700</b>
<b>14x2</b>	11	22	<b>209 00 00800</b>	
<b>16x2</b>	13	24	<b>209 00 00900</b>	
<b>20x2,5</b>	16	30	<b>209 00 01100</b>	

## Low self locking hexagon nuts

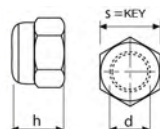

- Strength class 6s
- With nylon ring inserted
- DIN 985

Code	Desc.	h	s
2270000250	5	5	8
2270000350	6	6	10
2270000650	8	8	13
2270000950	10	10	17
2270001250	12	12	19

## High self locking hexagon nuts

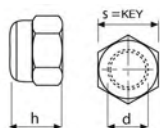

- Class resist.: 6S
- With nylon ring inserted
- UNI 7473
- DIN 982

DESCR.	MEASURES		GALVANIZED STEEL	STAINLESS STEEL A2 - AISI 304
	d x step	h	CODE	CODE
<b>3</b>	4	5,5		<b>227 A2 00050</b>
<b>4</b>	5,8	7	<b>227 00 00100</b>	<b>227 A2 00100</b>
<b>5</b>	6,7	8	<b>227 00 00200</b>	<b>227 A2 00200</b>
<b>6</b>	7,6	10	<b>227 00 00300</b>	<b>227 A2 00300</b>
<b>7</b>	8,5	11	<b>227 00 00400</b>	
<b>8x1</b>	10,4	13	<b>227 00 00500</b>	
<b>8x1,25</b>	10,4	13	<b>227 00 00600</b>	<b>227 A2 00400</b>
<b>10x1</b>	12,1	17	<b>227 00 00750</b>	
<b>10x1,5</b>	12,1	17	<b>227 00 00800</b>	<b>227 A2 00500</b>
<b>10x1,25</b>	12,1	17	<b>227 00 00900</b>	
<b>12x1,25</b>	14,6	19	<b>227 00 01000</b>	
<b>12x1,5</b>	14,6	19	<b>227 00 01100</b>	
<b>12x1,75</b>	14,6	19	<b>227 00 01200</b>	<b>227 A2 00600</b>
<b>14x1,5</b>	16,4	22	<b>227 00 01300</b>	
<b>14x2</b>	16,4	22	<b>227 00 01400</b>	
<b>16x1,5</b>	17,8	24	<b>227 00 01500</b>	
<b>16x2</b>	17,8	24	<b>227 00 01520</b>	
<b>18x1,5</b>	21,5	27	<b>227 00 01600</b>	
<b>18x2,5</b>	21,5	27	<b>227 00 01630</b>	
<b>20x1,5</b>	23,3	30	<b>227 00 01700</b>	
<b>20x2,5</b>	23,3	30	<b>227 00 01800</b>	
<b>22x1,5</b>	25,6	32	<b>227 00 01900</b>	
<b>22x2,5</b>	25,6	32	<b>227 00 01950</b>	
<b>24x3</b>	28,8	36	<b>227 00 02000</b>	
<b>27x3</b>	31,2	41	<b>227 00 02060</b>	
<b>30x3,5</b>	33	46	<b>227 00 02100</b>	

## Assorted self locking nuts



- Contents: 9 measures of self-locking nuts DIN 982 diam. 5 in diameter. 14 coarse and fine pitch.
- Total 600 pieces.
- Supplied in a plastic carrying case n / s cod. 398 00 01900 abh4.

Code	Desc.
2270100100	9

### Content kit

CODE	DESCRIPTION	PCS
227 00 00200	5	200
227 00 00300	6	100
227 00 00800	10X1,5	50
227 00 01100	12X1,5	25
227 00 01200	12X1,75	25
227 00 01300	14X1,5	25
227 00 01400	14X2	25
227 00 00600	8X1,25	100
227 00 00900	10X1,25	50



## Self locking hexagon nuts in inches

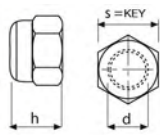

DESCR.	UNC	UNF
d	CODE	CODE
1/4"	228 00 00100	229 00 00100
5/16"	228 00 00200	229 00 00200
3/8"	228 00 00300	229 00 00300
7/16"	228 00 00400	229 00 00400
1/2"	228 00 00500	229 00 00500
9/16"	228 00 00600	229 00 00600
5/8"	228 00 00750	229 00 00750
3/4"	228 00 00800	229 00 00800
7/8"	228 00 00900	229 00 00900

- Class resist .: 6S.
- With nylon ring inserted.
- Galvanized steel.

## Hex nuts in inches

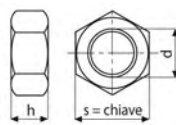

DESCR.	MEASURES	UNC	UNF
d	h	CODE	CODE
1/4"	5,5	211 00 00100	212 00 00100
5/16"	6,7	211 00 00200	212 00 00200
3/8"	8,3	211 00 00300	212 00 00300
7/16"	9,5	211 00 00400	212 00 00400
1/2"	11,1	211 00 00500	212 00 00500
9/16"	13,8	211 00 00600	212 00 00600
5/8"	13,8	211 00 00750	212 00 00750
3/4"	16,2	211 00 00800	212 00 00800
7/8"	19	211 00 00900	212 00 00900
1"	21,8	211 00 01000	212 00 01000

- Class resist .: 6S (class 8).
- ANSI B 18-2-2.
- Raw steel.

## Metal self locking hexagon nuts

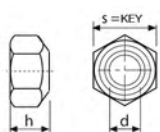

- Strength class: 6s (Class 8)
- white galvanized
- DIN 980

Code	Desc. d x pace	s	h
2140000100	6	10	6
2140000200	8x1,25	13	8
2140000400	10x1,5	17	10
2140000500	12x1,75	19	12
2140000600	14x2	22	14
2140000700	16x2	24	16

2

## Self locking hexagon nuts hexagon auburn normal

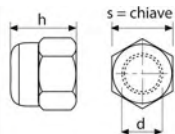

- Heat resistance: + 400 ° C

Code	Desc. d x pace	s key	h
2240000100	6x1	10	9
2240000150	8x1,25	13	11

## Self locking hexagon nuts hexagon auburn reduced

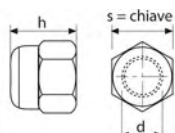

- Heat resistance: + 400 ° C

Code	Desc. d x pace	s key	h
2230000150	8x1	12	11
2230000200	8x1,25	12	11
2230000300	10x1,5	14	11
2230000350	10x1,25	14	11
2230000400	12x1,75	17	11

## Hex nuts for exhaust manifolds

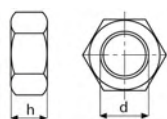

- Class resist. : 6S (Class 8)
- treated steel

Code	Desc. d x pace
2100000050	8x1,25 - h16
2100000090	10x1,25 - h10
2100000100	10x1,25 - h20

## Blind nut galvanized



- White galvanized steel.
- UNI 5721.
- DIN 1587.

Code	Desc. d x pace	Wrench S
216ZB01000	3X0,5	5.5
216ZB01010	4X0,7	7
216ZB01020	5X0,8	8
216ZB01030	6X1	10
216ZB01040	8X1,25	13
216ZB01050	10X1,50	17
216ZB01060	12X1,75	19
216ZB01070	14X2	22
216ZB01080	16X2	24

## Blind nut Inox

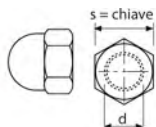

- Inox A2 AISI 304.
- UNI 5721.
- DIN 1587.

Code	Desc. d x pace	s key
216A200100	4	7
216A200200	5	8
216A200300	6	10
216A200400	8x1,25	13
216A200500	10x1,5	17
216A200600	12x1,75	19

## Butterfly nuts white galvanized



- Class di resist. : 6s
- UNI 5448
- DIN 315

Code	Desc.
2130000500	M 3X0.5
2130000510	M 4X0.7
2130000520	M 5X0.8
2130000095	M 6X1
2130000100	M 8X1.25
2130000200	M 10X1.5
2130000300	M 12X1.75

## Flanged nuts

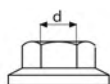

- Strength class: 6s
- Galvanized steel. DIN 6923
- Smooth under-head

Code	Desc.	d	Wrench S
2930000094	94	M4x0,7	7
2930000095	95	M5x0,8	8
2930000096	96	M6x1,0	10
2930000097	97	M8x1,25	13
2930003092	3092	M10x1,5	17
2930003093	3093	M12x1,75	19
2930005700	5700	M14x2,0	22
2930005710	5710	M16x2,0	24
2930005720	5720	M18x2,5	27
2930005730	5730	M20x2,5	30

## Caps glass steel

2



- Application of engine block

Code	Desc. Ø mm
384000200	10
384000300	12
384000400	14
384000500	16
384000600	18
384000700	20
384000800	22
3840001000	25
3840001100	28
3840001200	30
3840001300	32
3840001400	36
3840001600	40
3840001700	42
3840001800	45
3840001820	50
3840001900	56
3840002000	60



## Screw steel head burnished hexagon socket

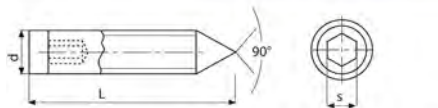

d=diameter	4	5	6	8	10	12
s= key	2	2,5	3	4	5	6

- Strength class: 12.9.
- UNI 5927.
- With tip.

Code	Desc. D x L
1950000010	3x8
1950000020	3x10
1950000040	3x14
1950000050	4x6
1950000060	4x8
1950000100	4x10
1950000300	4x16
1950000400	4x20
1950000440	5x6
1950000450	5x8
1950000500	5x10
1950000550	5x12
1950000620	5x16
1950000700	5x20
1950000740	6x6
1950000750	6x8
1950000800	6x10
1950000850	6x14
1950000900	6x16
1950001000	6x20
1950001050	8x8
1950001060	8x10
1950001070	8x12
1950001140	8x16
1950001200	8x20
1950001250	8x30
1950001255	10x10
1950001260	10x14
1950001300	10x16
1950001400	10x20
1950001500	10x25
1950001600	10x30
1950002500	14x16

## Screw A2 stainless steel head hexagon socket

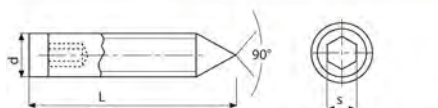

d=diameter	4	5	6	8	10	12
s= key	2	2,5	3	4	5	6

- A2 stainless steel AISI 304.
- UNI 5927.
- With tip.

Code	Desc. D x L
195A200050	4x10
195A200100	5x6
195A200200	6x6
195A200250	6x10
195A200300	6x16
195A200400	6x20
195A200500	8x8
195A200600	8x10
195A200700	8x12
195A200800	8x16
195A200900	8x20
195A201000	10x10
195A201100	10x16
195A201300	10x30

## Sets grub screw 6 Allen burnished steel

2



- Contents: 12 measures of grain Hexagon socket UNI 5927 da 3x8 has 10x10.
- Total 462 pieces.
- Supplied in plastic case n / t cod. 398 00 01700 200.

Code	Desc.
1950100100	12

**Contenuto kit**

CODICE	DESCRIZIONE	Q.tà
195 00 00010	3X8 GRANO C.ESAG.ACC.	50
195 00 00100	4X10 GRANO C.ESAG.ACC.	50
195 00 00300	4X16 GRANO C.ESAG.ACC.	50
195 00 00400	4X20 GRANO C.ESAG.ACC.	50
195 00 00450	5X8 GRANO C.ESAG.ACC.	50
195 00 00550	5X12 GRANO C.ESAG.ACC.	50
195 00 00620	5X16 GRANO C.ESAG.ACC.	50
195 00 00800	6X10 GRANO C.ESAG.ACC.	25
195 00 00900	6X16 GRANO C.ESAG.ACC.	25
195 00 01070	8X12 GRANO C.ESAG.ACC.	25
195 00 01250	8X30 GRANO C.ESAG.ACC.	12
195 00 01255	10X10 GRANO C.ESAG.ACC.	25

## threaded rods

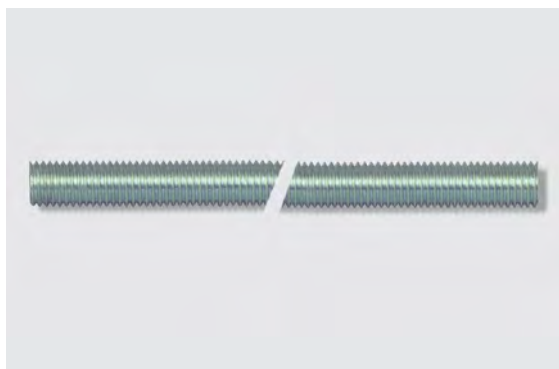

DESCR.	RAW IRON	STEEL INOX A2	GALVANIZED IRON
Ø x step	CODE	CODE	CODE
4x0,7	<b>396 OG 00004</b>		<b>396 ZN 00100</b>
5x0,8	<b>396 OG 00005</b>	<b>396 A2 00100</b>	<b>396 ZN 00200</b>
6x1	<b>396 OG 00010</b>	<b>396 A2 00200</b>	<b>396 ZN 00300</b>
8x1,25	<b>396 OG 00012</b>	<b>396 A2 00300</b>	<b>396 ZN 00400</b>
10x1,5	<b>396 OG 00016</b>	<b>396 A2 00350</b>	<b>396 ZN 00500</b>
12x1,75	<b>396 OG 00025</b>	<b>396 A2 00360</b>	<b>396 ZN 00600</b>
14x2	<b>396 OG 00030</b>	<b>396 A2 00370</b>	<b>396 ZN 00700</b>
16x2	<b>396 OG 00040</b>	<b>396 A2 00400</b>	<b>396 ZN 00800</b>
18x2,5	<b>396 OG 00050</b>	<b>396 A2 00450</b>	<b>396 ZN 00900</b>
20x2,5	<b>396 OG 00060</b>	<b>396 A2 00500</b>	<b>396 ZN 01000</b>
22x2,5	<b>396 OG 00100</b>		<b>396 ZN 01100</b>
24x3	<b>396 OG 00200</b>		<b>396 ZN 01200</b>
27x3	<b>396 OG 00300</b>		<b>396 ZN 01300</b>
30x3,5	<b>396 OG 00400</b>		<b>396 ZN 01400</b>

- Strength class: 4.6.
- 1 meter length.

## Galvanized steel bars 8.8

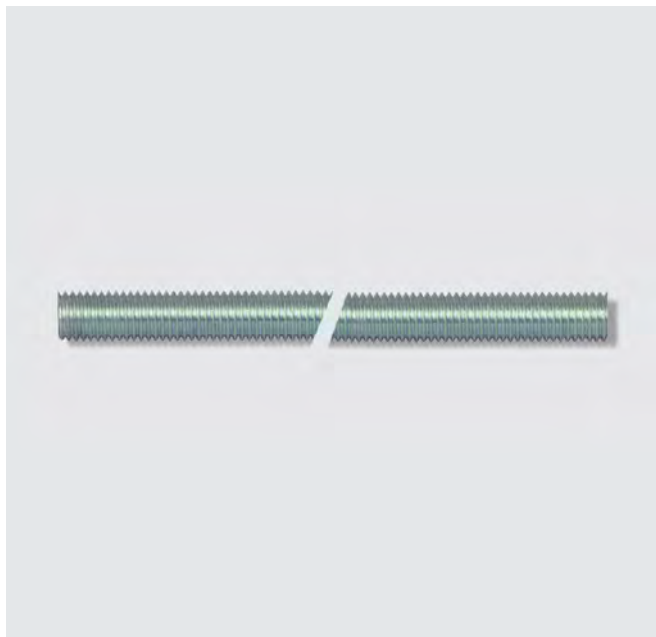

- Threaded rods Rolled steel with resistenza 8.8 class, electrolytic galvanizing surface with a thickness of 5  $\mu$ .
- Available in lengths from 1 meter, metric coarse thread MA. Specifications UNI 6547 - DIN 975.

2

Code	Desc. <i>Measure</i>	Nominal stress area <i>(As nom) [mm<sup>2</sup>]</i>	Test load <i>(As x Rm) [N]</i>	Minimum breaking load <i>(As x Rm) [N]</i>
396ZN02000	M6X1	20,1	11600	16100
396ZN02010	M8X1,25	36,6	21200	29200
396ZN02020	M10X1,5	58,0	33700	46400
396ZN02030	M12X1,75	84,3	48900	67400
396ZN02040	M14X2	115,0	66700	92000
396ZN02050	M16X2	157,0	91000	125000
396ZN02060	M18X2,5	192,0	115000	159000
396ZN02070	M20X2,5	245,0	147000	203000
396ZN02080	M22X2,5	303,0	182000	252000
396ZN02090	M24X3	353,0	212000	293000
396ZN02100	M27X3	459,0	275000	381000
396ZN02110	M30X3,5	561,0	337000	466000

## Coupling sleeve white galvanized



- Material steel class 4.8.
- White galvanized finish.
- Female thread on both sides.

Code	Desc.	Wrench	FIL. XL.
208MA00100	M6x30	10	6x30
208MA00200	M8x40	13	8x40
208MA00300	M10x45	17	10x45
208MA00400	M12x50	19	12x50

## Studs

2



- Strength class: 6S (class 8).

Code	Material type
19300****	IRON TREATY

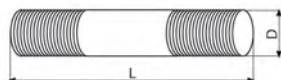

## Studs assortment



- Contents: 12 measures of a stud 6x21 6x56, 8x28 to 8x70 is not 1.25, 10x45 to 10x95 has not 1.25, from 12x53 to 12x108 not 1.25.
- Total 140 pieces.
- Supplied in plastic case n / t cod. 398 00 01900 ABH4.

Code	Desc.
1930100100	12

### Content kit

CODE	DESCRIPTION	PCS
193 00 07400	12X108X1,25	10
193 00 00100	6X21	20
193 00 00600	6X32	20
193 00 01300	6X56	10
193 00 02000	8X28X1,25	10
193 00 02300	8X34X1,25	10
193 00 03800	8X70X1,25	10
193 00 04900	10X45X1,25	10
193 00 05400	10X65X1,25	10
193 00 06000	10X95X1,25	10
193 00 07000	12X78X1,25	10
193 00 06600	12X53X1,25	10



## Washers for countersunk screws



- Yellow galvanized steel.
- Specifications for our screws 219 TX.
- They turn the screws in the anchor bolts with mechanical characteristics definitely higher and a greater resting surface.

2

Code	Description	Diameters	D1	D2
246TR00010	6-WASHERS FOR SCREWS COUNTERSUNK HEAD	M6	7,8	19,5
246TR00015	8-WASHERS FOR SCREWS COUNTERSUNK HEAD	M8	9	25
246TR00020	10-WASHERS FOR SCREWS COUNTERSUNK HEAD	M10	12	32

## Washers Uni 6592

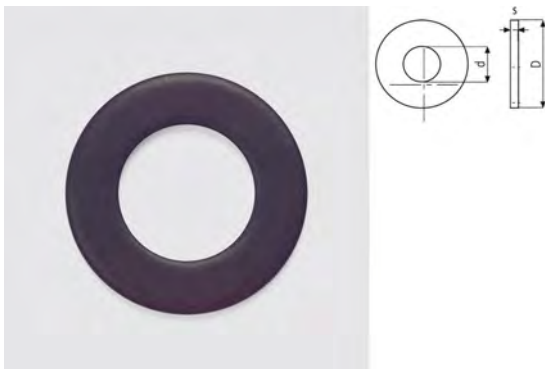

- For T.E. screws

DESCR.	MEASURES			BURNISHED STEEL	WHITE GALVANIZED STEEL	STEEL INOX A2 AISI 304	STEEL INOX A4 AISI 316
	X SCREWS	d	D	s	CODE	CODE	CODE
<b>3</b>	3,2	7	0,5	<b>244 00 00100</b>	<b>245 00 00050</b>	<b>247 00 00050</b>	
<b>4</b>	4,3	9	0,8	<b>244 00 00200</b>	<b>245 00 00100</b>	<b>247 00 00100</b>	<b>247 A4 00200</b>
<b>5</b>	5,3	10	1	<b>244 00 00300</b>	<b>245 00 00200</b>	<b>247 00 00200</b>	<b>247 A4 00300</b>
<b>6</b>	6,4	12,5	1,6	<b>244 00 00400</b>	<b>245 00 00300</b>	<b>247 00 00300</b>	<b>247 A4 00400</b>
<b>7</b>	7,4	14	1,6	<b>244 00 00500</b>	<b>245 00 00400</b>		
<b>8</b>	8,4	17	1,6	<b>244 00 00600</b>	<b>245 00 00500</b>	<b>247 00 00500</b>	<b>247 A4 00500</b>
<b>10</b>	10,5	21	2	<b>244 00 00700</b>	<b>245 00 00600</b>	<b>247 00 00600</b>	<b>247 A4 00600</b>
<b>12</b>	13	24	2,5	<b>244 00 00800</b>	<b>245 00 00700</b>	<b>247 00 00700</b>	<b>247 A4 00700</b>
<b>14</b>	15	28	2,5	<b>244 00 00900</b>	<b>245 00 00800</b>	<b>247 00 00800</b>	<b>247 A4 00800</b>
<b>16</b>	17	30	3	<b>244 00 01000</b>	<b>245 00 00900</b>	<b>247 00 00900</b>	<b>247 A4 00900</b>
<b>18</b>	19	34	3	<b>244 00 01100</b>	<b>245 00 01000</b>	<b>247 00 01000</b>	<b>247 A4 01000</b>
<b>20</b>	21	37	3	<b>244 00 01200</b>	<b>245 00 01100</b>		
<b>22</b>	23	39	3	<b>244 00 01300</b>	<b>245 00 01120</b>		
<b>24</b>	25	44	4	<b>244 00 01400</b>	<b>245 00 01130</b>		
<b>27</b>	28	50	4	<b>244 00 01500</b>	<b>245 00 01135</b>		
<b>30</b>	31	56	4	<b>244 00 01700</b>	<b>245 00 01140</b>		
<b>33</b>	34	60	5	<b>244 00 01800</b>			
<b>36</b>	37	65	5	<b>244 00 01900</b>			

## Washers in inches galvanized

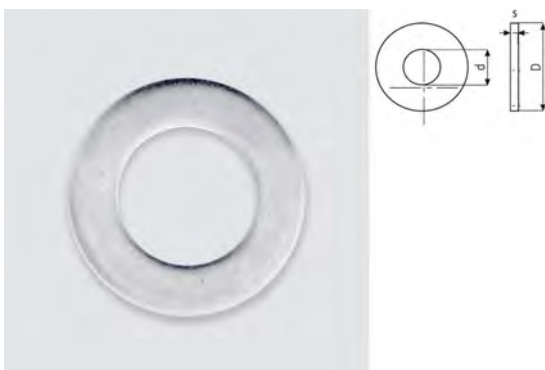

- For T.E. screws

Code	Descr. inches for screws	Measures d	Measures D	Measures s	
2450C00050	1/4	6,4	12,5	1,6	GA
2450C00100	5/16	8,4	17	1,6	GA
2450C00150	3/8	9,5	18	1,5	GA
2450C00175	7/16	11,6	23	2	GA
2450C00200	1/2	13,5	24	2,5	GA
2450C00250	9/16	15	28	2,5	GA
2450C00300	5/8	17	30	3	GA
2450C00400	3/4	20	38	3	GA
2450C00500	7/8	23	39	3	GA

## Sheet metal washers

2

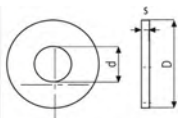

- For T.E. screws
- UNI 6593.

DESCR.	MEASURES			YELLOW GALVANIZED STEEL	WHITE GALVANIZED STEEL	STEEL INOX A2 AISI 304
	X SCREWS	d	D	s	CODE	CODE
<b>4x12</b>	4,3	12	1	<b>248 00 00050</b>	<b>248 ZN 00100</b>	
<b>4x16</b>	4,3	16	1,6	<b>248 00 00060</b>	<b>248 ZN 00200</b>	<b>248 A2 00060</b>
<b>5x15</b>	5,5	15	1,6	<b>248 00 00100</b>	<b>248 ZN 00300</b>	<b>248 A2 00100</b>
<b>5x20</b>	5,3	20	1,6	<b>248 00 00200</b>	<b>248 ZN 00400</b>	<b>248 A2 00150</b>
<b>6x18</b>	6,6	18	2	<b>248 00 00300</b>	<b>248 ZN 00500</b>	<b>248 A2 00200</b>
<b>6x24</b>	6,6	24	2	<b>248 00 00400</b>	<b>248 ZN 00600</b>	<b>248 A2 00250</b>
<b>8x24</b>	9	24	2	<b>248 00 00500</b>	<b>248 ZN 00700</b>	<b>248 A2 00300</b>
<b>8x32</b>	9	32	2,5	<b>248 00 00600</b>	<b>248 ZN 00800</b>	<b>248 A2 00350</b>
<b>10x30</b>	11	30	2,5	<b>248 00 00700</b>	<b>248 ZN 00900</b>	<b>248 A2 00400</b>
<b>10x40</b>	11	40	3	<b>248 00 00800</b>	<b>248 ZN 01000</b>	<b>248 A2 00450</b>
<b>12x36</b>	14	36	3	<b>248 00 00900</b>	<b>248 ZN 01100</b>	<b>248 A2 00500</b>
<b>12x48</b>	14	48	3	<b>248 00 01000</b>	<b>248 ZN 01200</b>	<b>248 A2 00600</b>
<b>14x42</b>	16	42	3	<b>248 00 01100</b>	<b>248 ZN 01300</b>	<b>248 A2 00700</b>
<b>16x48</b>	16	48	3		<b>248 ZN 01130</b>	
<b>20x54</b>	20	54	3		<b>248 ZN 01800</b>	
<b>20x60</b>	20	60	3		<b>248 ZN 01810</b>	

## Spring washers

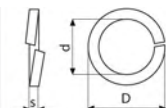

- Ruggedized.
- Rectangular section.
- Sharp edges.
- UNI 1751B.
- DIN 127B.

DESCR.	MEASURES			BURNISHED STEEL	YELLOW GALVANIZED STEEL	WHITE GALVANIZED STEEL	STEEL INOX A2 - AISI 304
	X SCREWS	d	D	s	CODE	CODE	CODE
<b>4</b>	4,3	7,3	1	<b>266 00 00100</b>			<b>270 00 00040</b>
<b>5</b>	5,3	9,3	1,5	<b>266 00 00200</b>	<b>266 0C 00080</b>		<b>270 00 00050</b>
<b>6</b>	6,45	11,4	1,8	<b>266 00 00300</b>	<b>266 0C 00090</b>	<b>267 00 00250</b>	<b>270 00 00100</b>
<b>8</b>	8,4	14,4	2,5	<b>266 00 00500</b>	<b>266 0C 00200</b>	<b>267 00 00300</b>	<b>270 00 00200</b>
<b>10</b>	10,5	17,5	2,7	<b>266 00 00700</b>	<b>266 0C 00250</b>	<b>267 00 00350</b>	<b>270 00 00300</b>
<b>12</b>	13	21	3,2	<b>266 00 00800</b>	<b>266 0C 00300</b>	<b>267 00 00400</b>	<b>270 00 00400</b>
<b>14</b>	15	24	3,5	<b>266 00 00900</b>	<b>266 0C 00400</b>	<b>267 00 00450</b>	<b>270 00 00450</b>
<b>16</b>	17	27,4	3,8	<b>266 00 01000</b>	<b>266 0C 00450</b>	<b>267 00 00480</b>	<b>270 00 00500</b>
<b>18</b>	19	30	4	<b>266 00 01100</b>	<b>266 0C 00500</b>	<b>267 00 00500</b>	
<b>20</b>	21	33	4,5	<b>266 00 01200</b>	<b>266 0C 00600</b>	<b>267 00 00600</b>	
<b>22</b>	23	36	5	<b>266 00 01300</b>			
<b>24</b>	25	39	5,5	<b>266 00 01400</b>			

## Washers outdoor-indoor range white galvanized - stainless A2



DESCR.	MEASURES		EXTERNAL DENTURES STEEL C 70	INTERNAL DENTURES STEEL C 70	EXTERNAL DENTURES STEEL INOX A2 - AISI 304
	X SCREWS mm	d	D	CODE	CODE
4	4,3	8	<b>252 ZN 00050</b>		
5	5,1	9	<b>252 ZN 00100</b>		
6	6,4	11	<b>252 ZN 00200</b>	<b>251 ZN 00200</b>	<b>252 A2 00050</b>
8	8,4	14	<b>252 ZN 00400</b>	<b>251 ZN 00400</b>	<b>252 A2 00060</b>
10	10,5	18	<b>252 ZN 00600</b>	<b>251 ZN 00600</b>	<b>252 A2 00100</b>
12	12,5	20,5	<b>252 ZN 00700</b>	<b>251 ZN 00700</b>	<b>252 A2 00200</b>

- Spring steel C 70
- DIN 6798
- Galvanized finish white
- stainless A2

## Elastic conical washer table Fiat 10187

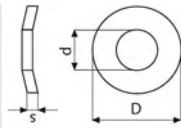

- Steel C 70

Code	Descr. for screws	d	D	s
2460000100	6	6,4	12	1,2
2460000150	7	7,4	13	1,2
2460000200	8	8,4	15	1,5
2460000300	10	10,5	20	2,3
2460000400	12	12,5	24	2,5
2460000500	14	14,5	32	3,5
2460000600	16	16,5	34	3,5
2460000700	18	18,7	36	4

## Schnorr washers

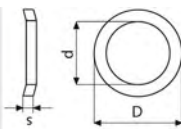

Code	Desc. Measure	d	D	s
2920000100	4	4,3	7	0,5
2920000200	5	5,3	8,5	0,6
2920000300	6	6,4	10	0,7
2920000500	8	8,4	13	0,8
2920000600	10	10,5	16	1
2920000700	12	13	18	1
2920000800	14	15	21	1,2
2920000900	16	17	24	1,2
2920001000	18	19	27	1,5

## Wave washers type "B" galvanized white

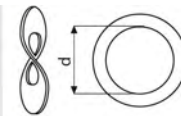

- DIN 137.
- Steel C70.
- White galvanized finish.

Code	Desc. d
255ZN00100	4
255ZN00200	5
255ZN00300	6
255ZN00500	8
255ZN00600	10
255ZN00700	12

## Copper washers toric section

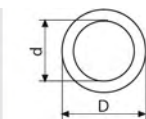

- Heat resistance: + 900 ° C
- With padding, asbestos-free (hovoseal)

Code	Desc. d x D
2770000100	6x10
2770000300	8x13
2770000600	10x15
2770000700	12x17
2770000800	14x20
2770000900	16x22
2770001100	18x24
2770001200	20x26
2770001300	22x27

2

## Aluminum washers

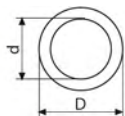

- Heat resistance: + 300 ° C
- Thickness mm 1,5

Code	Desc. d x D
2780000100	6x10
2780000200	6x12
2780000300	7x14
2780000400	8x12
2780000500	8x14
2780000600	9x15
2780000700	10x14
2780000800	10x16
2780000900	12x16
2780001000	12x18
2780001100	14x18
2780001200	14x20
2780001300	16x20
2780001400	16x22
2780001500	18x22
2780001600	18x24
2780001700	20x26
2780001800	20x28
2780001900	22x28
2780002000	24x30
2780002100	26x32
2780002200	28x34
2780002300	30x36
2780002400	30x38
2780002500	32x38
2780002600	40x48

## Fiber washers

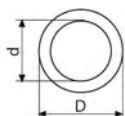

- Heat resistance: + 90 ° C
- 1.5mm

Code	Desc. d x D
2800000100	6x10
2800000200	6x12
2800000300	7x14
2800000400	8x12
2800000500	8x14
2800000600	8x16
2800000800	10x14
2800000900	10x16
2800001000	12x16
2800001100	12x18
2800001200	14x18
2800001300	14x20
2800001400	16x22
2800001500	16x24
2800001600	18x24
2800001800	20x26
2800002000	20x28
2800002100	22x28
2800002300	26x32
2800002600	30x38



## Washers sealing fluids

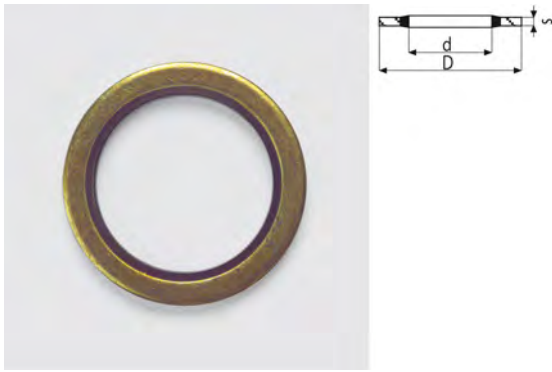

- Components: Outer ring of carbon steel, inner ring trapezoidal rubber NBR 90 Shore A.

Code	Descr. for screws	d mm	D mm	s mm	For screws inch	For screws pitch gas
2530000100	5	5,21	8,38	1,22	-	-
2530000200	6	6,86	13,21	1,22	1/4	-
2530000300	8	8,64	14,22	1,22	5/16	-
2530000400	10	11,26	18,36	2,03	-	-
2530000500	11	11,69	13,05	2,03	7/16	-
2530000600	12	13,74	20,57	2,03	1/2	1/4
2530000700	14	14,86	22,23	2,03	9/16	-
2530000800	16	16,51	25,40	2,03	5/8	-
2530000850	17	17,28	23,80	2,03	-	3/8
2530000900	18	19,69	26,92	2,34	3/4	-
2530001000	20	21,54	28,58	2,34	13/16	1/2
2530001100	22	23,49	31,75	2,34	7/8	5/8
2530001200	24	24,26	33,27	2,34	15/16	-
2530001300	26	27,05	34,93	2,34	1"	3/4
2530001400	27	27,82	38,61	2,34	1" - 1/16	-
2530001500	28	29,33	36,58	2,34	1" - 1/8	-
2530001600	30	30,81	38,10	2,34	1" - 3/16	7/8
2530001700	33	33,89	42,80	3,25	1" - 5/16	1"
2530001800	42	42,93	52,38	3,25	1" - 5/8	1" - 1/4
2530001900	48	48,44	58,60	3,25	1" - 7/8	1" - 1/2



## Washers sealing fluids



- Pattern Nylon specific for Ford.
- For Renault.

Code	Description	Dim. D x d x s	Photo
2530000860	17/1 -Washers sealing fluids Renault	24x17x13	2
2530003000	22x15x2 - Nylon Washers sealing fluids Ford	22x15x2	1
2530003100	12.8x20x2 - Nylon Washers sealing fluids Ford	12.8x20x2	1

## Copper washers gas dimensions

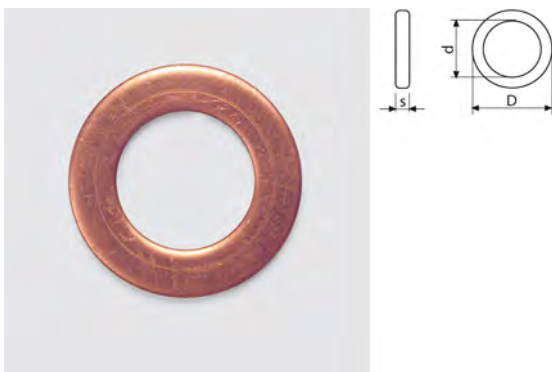

- Heat resistance: + 900 ° C

Code	Desc. d	s	Corresp in mm.
2760004200	1/8GAS	1,5	10X14
2760004300	1/4GAS	1,5	13X20
2760004400	5/16GAS	1,5	15X22
2760004500	3/8GAS	1,5	17X23
2760004600	1/2GAS	1,5	21X27
2760004800	3/4GAS	1,5	27X33
2760004900	7/8GAS	1,5	30X36
2760005100	1-1/4GAS	1,5	42X50
2760005200	1-1/2GAS	1,5	48X58

2

## Copper washers toric section

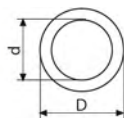

- Heat resistance: + 900 ° C
- With padding, asbestos-free (hovoseal)

Code	Desc. d x D
2770000100	6x10
2770000300	8x13
2770000600	10x15
2770000700	12x17
2770000800	14x20
2770000900	16x22
2770001100	18x24
2770001200	20x26
2770001300	22x27

## Copper washers millimeters dimensions

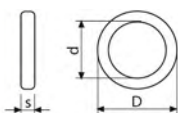

- Heat resistance: + 900 ° C.

Code	Desc. d x D	s
2760000100	6x10	1,5
2760000150	6x10	0,80
2760000200	6x12	1,5
2760000400	8x12	1,5
2760000450	8x12	0,80
2760000500	8x14	1,5
2760000600	9x15	1,5
2760000700	10x14	1,5
2760000800	10x16	1,5
2760001000	12x16	1,5
2760001100	12x18	1,5
2760001200	14x18	0,2
2760001300	14x18	1,5
2760001400	14x20	1,5
2760001500	14x22	1,5
2760001600	14x24	1,5
2760001700	16x20	1,5
2760001800	16x22	1,5
2760001900	18x22	1,5
2760002000	18x24	1,5
2760002100	20x26	1,5
2760002200	20x28	1,5
2760002300	22x26	1,5
2760002400	22x28	1,5
2760002500	24x30	1,5
2760002700	26x32	1,5
2760002800	26x34	1,5
2760002900	28x36	1,5
2760003000	30x38	1,5
2760003100	32x38	1,5
2760003150	35x43	1,5
2760003170	36x44	1,5
2760003200	38x46	1,5
2760003300	40x48	1,5

## Assortment flat washers galvanized



- Contents: 12 measures galvanized washers UNI 6592 diam. 4 to diam. 22.
- Total 430 pieces.
- Supplied in a plastic carrying case our cod. 398 00 01700 200.

2

Code	Desc.
2450100100	12

### Contenuto kit

CODICE	DESCRIZIONE	Q.tà
245 00 00400	7 -RONDELLA PIANA ZINCATA	60
245 00 00500	8 -RONDELLA PIANA ZINCATA	40
245 00 00600	10-RONDELLA PIANA ZINCATA	20
245 00 00700	12-RONDELLA PIANA ZINCATA	20
245 00 00800	14-RONDELLA PIANA ZINCATA	10
245 00 00900	16-RONDELLA PIANA ZINCATA	8
245 00 01000	18-RONDELLA PIANA ZINCATA	8
245 00 01100	20-RONDELLA PIANA ZINCATA	2
245 00 01120	22-RONDELLA PIANA ZINCATA	2
245 00 00100	4 -RONDELLA PIANA ZINCATA	100
245 00 00200	5 -RONDELLA PIANA ZINCATA	100
245 00 00300	6 -RONDELLA PIANA ZINCATA	60

## Banners washers assortment ZJ



- Contents: 9 measures yellow headbands galvanized washers UNI 6593 4x12 to 10x30.
- Total 850 parts.
- Supplied in plastic case n / t cod. 398 00 01900 ABH4.

Code	Desc.
2480100100	12

### Content kit

CODE	DESCRIPTION	PCS
248 00 00060	4X16	100
248 00 00100	5X15	100
248 00 00200	5X20	100
248 00 00300	6X18	100
248 00 00400	6X24	100
248 00 00500	8X24	100
245 00 00100	8X32	100
245 00 00200	10X30	50
245 00 00300	4X12	150

## Assortment spring washers reinforced burnished



- Contents: 12 sizes of spring washers reinforced by dim. 4 to diam. 20
- Total 486 pieces
- Supplied in a plastic carrying case n / s cod. 398 00 01 700 200

Code	Desc.
2660100100	12

### Content kit

CODE	DESCRIPTION	PCS
266 00 00100	4	150
266 00 00200	5	150
266 00 00300	6	50
266 00 00400	7	50
266 00 00500	8	25
266 00 00700	10	25
266 00 00800	12	12
266 00 00900	14	6
266 00 01000	16	6
266 00 01100	18	6
266 00 01200	20	6

## Assorted copper washers



- Content: 18 measures copper washers from 6x10 to 26X32.
- Total 623 pieces.
- Supplied in a plastic carrying case our cod. 398 00 01800 201.

Code	Desc.
2760100200	18

### Content kit

CODE	DESCRIPTION	PCS
276 00 00100	6X10	50
276 00 00200	6X12	50
276 00 00600	9X15	50
276 00 00400	8X12	50
276 00 00500	8X14	50
276 00 00700	10X14	50
276 00 00800	10X16	50
276 00 01000	12X16	50
276 00 01100	12X18	50
276 00 01300	14X18	25
276 00 01400	14X20	25
276 00 01800	16X22	25
276 00 01900	18X22	25
276 00 02000	18X24	25
276 00 02200	20X28	12
276 00 02300	22X26	12
276 00 02500	24X30	12
276 00 02700	26X32	12



## Assorted copper washers toric section



- Contents: 12 sizes of copper washers toric section from 6x10 to 22x27.
- Total 190 pieces.
- Supplied in a plastic carrying case our cod. 398 00 01700 200.

Code	Desc.
2770100200	12

### Content kit

CODE	DESCRIPTION	PCS
277 00 00100	6X10	30
277 00 00300	8X13	25
277 00 00600	10X15	25
277 00 00700	12X17	25
277 00 00800	14X20	10
277 00 00900	16X22	20
277 00 01100	18X24	10
277 00 01200	20X26	10
277 00 01300	22X27	10

## Assortment aluminum washers



- Content: 18 measures aluminum washers from 6x10 to 26X32.
- Total 762 pieces.
- Supplied in a plastic carrying case n / s cod. 398 00 01800 201.

Code	Desc.
2780100200	18

### Content kit

CODE	DESCRIPTION	PCS
278 00 00100	6X10	100
278 00 00200	6X12	100
278 00 00300	7X14	50
278 00 00400	8X12	50
278 00 00500	8X14	50
278 00 00600	9X15	50
278 00 00700	10X14	50
278 00 00800	10X16	50
278 00 00900	12X16	50
278 00 01000	12X18	50
278 00 01200	14X20	20
278 00 01300	16X20	20
278 00 01400	16X22	20
278 00 01600	18X24	20
278 00 01800	20X28	25
278 00 01900	22X28	25
278 00 02000	24X30	5
278 00 02100	26X32	5

## Assortment fiber washers

2



- Contents: 18 measures of fiber washers from 6x10 to 22x28.
- Total 448 pieces.
- Supplied in a plastic carrying case n / s cod. 398 00 01700 200.

Code	Desc.
2800100100	12

### Content kit

CODE	DESCRIPTION	PCS
280 00 00100	6X10	100
280 00 00200	6X12	50
280 00 00400	8X12	50
280 00 00500	8X14	50
280 00 00800	10X14	50
280 00 00900	10X16	50
280 00 01100	12X18	25
280 00 01300	14X20	25
280 00 01400	16X22	25
414 00 01200	18X24	12
414 00 01300	20X28	12
278 00 02100	22X28	12

## Tapping screws with cylindrical head cross

DIAMETRO	2,2	2,9	3,5-3,9-4,2-4,8	5,5-6,3	**** MISURE: VEDI LISTINO
IMPRONTA PH	1	1	2	3	

- UNI 6954.
- DIN 7981.

Code	Material
15800*****	GALVANIZED STEEL WHITE
16900*****	GALVANIZED STEEL BLACK
15700*****	STAINLESS STEEL A2-AISI 304
157A4*****	STAINLESS STEEL A4-AISI 316

## Tapping screws countersunk head cross

DIAMETER	2,2	2,9	3,5-3,9-4,2-4,8	5,5-6,3	**** sizes: see price list
IMPRONTA PH	1	1	2	3	

- UNI 6955.
- DIN 7982.

Code	Material
16100*****	STAINLESS STEEL A2-AISI 304
161A4*****	STAINLESS STEEL A4-AISI 316
16400*****	GALVANIZED STEEL WHITE
164ZN*****	GALVANIZED STEEL BLACK

## Tapping screws head half round

DIAMETER	4,8	5,5	**** sizes: see price list
HEAD DIAMETER	11	13	
IMPRONTA PH	2	3	

- UNI 6947.
- DIN 7981/C.

Code	Material
16700*****	GALVANIZED STEEL WHITE
167A2*****	STAINLESS STEEL A2 + 304
167TR*****	GALVANIZED STEEL YELLOW
167ZN*****	GALVANIZED STEEL BLACK

## Chipboard screws, self-tapping countersunk flat head



- UNI 3740 / 6A.
- Reinforced head for the transmission of high torques.
- The high depth of the thread increases the resistance of the fastener by approximately 30% compared to conventional screws.
- For measurements refer to the price list.
- Partial thread even in small sizes in the family ..... 219 00 and 219 BR .....

Code	Material
21900*****	C15 galvanized steel white
219A2*****	Stainless steel A2
219BR*****	Bronzed steel C15
219TR*****	Yellow galvanized steel C15 (tropicalized)

\*\*\*\*\* sizes: see price list

Diameter mm	2,5	3	3,5	4	4,5	5	6
Head diameter	5	6	7	8	9	10	12
Imprint	PZ 1	PZ 1	PZ 2	PZ 2	PZ 2	PZ 2	PZ 3

## Chipboard screws, self-tapping cylinder head



- Din 7505-b
- Hardened steel C1022
- Surface hardness 470-700 hv
- Core hardness 300-420 hv
- The high depth of the thread increases the resistance of the fastener by approximately 30% compared to conventional screws.
- For measurements refer to the price list.

Code	Material
22600*****	Galvanized steel tempered C1022 White
226TR*****	Hardened steel C1022 Tropicalised
226BR*****	Hardened steel C1022 Bronzed
226ZN*****	Galvanized steel tempered C1022 Black

Diameter mm	3	3,5	4	4,5	5	6
Head diameter mm	6	7	8	9	10	11
Head height mm	2,5	2,5	3	3	4	4
imprint	PZ 1	PZ 2	PZ 2	PZ 2	PZ 2	PZ 3



## Chipboard screws self-tapping Torx head half round



- Half round head screw with collar under head.
- Available galvanized yellow or black.
- Mainly used in the fixing of wooden strips, hinges, balconies, balconies, and supports.
- Field of use; wooden doors and windows, carpentry.
- Total thread and Torx head footprint.

Code	Desc. D x L	Imprint Torx	Type
219TN00100	5,5x20	T 30	galvanized black
219TN00110	5,5x25	T 30	galvanized black
219TN00120	5,5x30	T 30	galvanized black
219TN00130	5,5x35	T 30	galvanized black
219TN00140	5,5x40	T 30	galvanized black
219TN00150	5,5x45	T 30	galvanized black
219TN00160	6,0x25	T 30	galvanized black
219TN00170	6,0x30	T 30	galvanized black
219TN00180	6,0x35	T 30	galvanized black
219TN00190	6,0x40	T 30	galvanized black
219TN00200	6,0x45	T 30	galvanized black
219TN00210	6,0x50	T 30	galvanized black
219TG00100	5,5x20	T 30	galvanized yellow
219TG00110	5,5x25	T 30	galvanized yellow
219TG00120	5,5x30	T 30	galvanized yellow
219TG00130	5,5x35	T 30	galvanized yellow
219TG00140	5,5x40	T 30	galvanized yellow
219TG00150	5,5x45	T 30	galvanized yellow
219TG00160	6,0x25	T 30	galvanized yellow
219TG00170	6,0x30	T 30	galvanized yellow
219TG00180	6,0x35	T 30	galvanized yellow
219TG00190	6,0x40	T 30	galvanized yellow
219TG00200	6,0x45	T 30	galvanized yellow
219TG00210	6,0x50	T 30	galvanized yellow

## Self-tapping screws for chipboard TSP Torx

2

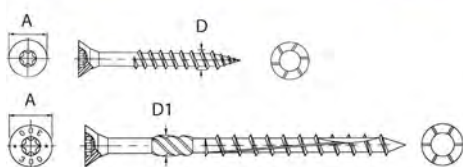
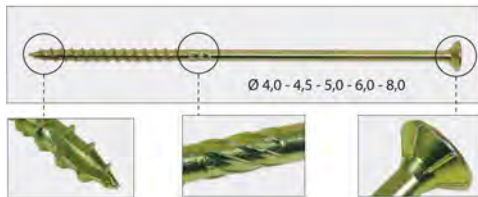

- Self-tapping screws for wood countersunk head with underhead autosavante, and Torx for better transmission of torque.
- Piercing tip milled from a diameter 4.0 mm, the chip breaker at the end of the thread for the removal of residues of drilling and decreasing the effort of the tool.
- Suitable for application on all types of wood, even hard, for wood structural works, construction of structures and roofs, gazebos, furniture, setting up caravans and caravans, and assembly of wooden buildings in general.
- Construction carbon steel tempered.
- Tip angle optimum for better penetration in the materials. Fillet with pronounced angle for to save time and energy tool.
- Self-lubricating coating to avoid any risk of seizing. Yellow zinc.

**TECHNICAL FEATURES:**

- Hardened steel C1022
- Surface hardness HV450-750
- Core hardness HV280-450

CODE	DESCRIPTION DxL mm.	Thread length mm	Diam. head A mm.	D1 mm.	Torx imprint
219 TX 03000	3,0X12	Totale	5,7	/	T10
219 TX 03010	3,0X16	Totale	5,7	/	T10
219 TX 03020	3,0X20	Totale	5,7	/	T10
219 TX 03030	3,0X25	Totale	5,7	/	T10
219 TX 03040	3,0X30	18	5,7	/	T10
219 TX 03050	3,0X35	21	5,7	/	T10
219 TX 03060	3,0X40	25	5,7	/	T10
219 TX 03070	3,5X16	Totale	6,6	/	T15
219 TX 03080	3,5X20	Totale	6,6	/	T15
219 TX 03090	3,5X25	Totale	6,6	/	T15
219 TX 03100	3,5X30	18	6,6	/	T15
219 TX 03110	3,5X35	21	6,6	/	T15
219 TX 03120	3,5X40	25	6,6	/	T15
219 TX 03130	3,5X45	28	6,6	/	T15
219 TX 03140	3,5X50	30	6,6	/	T15
219 TX 03146	4,0X16	11	7,4	3,8	T20
219 TX 03148	4,0X20	15	7,4	3,8	T20
219 TX 03148	4,0X25	25	7,4	3,8	T20
219 TX 03150	4,0X30	18	7,8	3,7	T20
219 TX 03160	4,0X35	20	7,8	3,7	T20
219 TX 03170	4,0X40	24	7,8	3,7	T20
219 TX 03180	4,0X45	27	7,8	3,7	T20
219 TX 03190	4,0X50	30	7,8	3,7	T20
219 TX 03200	4,0X60	35	7,8	3,7	T20
219 TX 03210	4,0X70	42	7,8	3,7	T20
219 TX 03220	4,5X40	24	8,8	3,8	T25
219 TX 03230	4,5X45	27	8,8	3,8	T25
219 TX 03240	4,5X50	30	8,8	3,8	T25
219 TX 03250	4,5X60	36	8,8	3,8	T25
219 TX 03260	4,5X70	42	8,8	3,8	T25
219 TX 03270	4,5X80	50	8,8	3,8	T25
219 TX 03280	5,0X40	24	9,8	4,2	T25
219 TX 03290	5,0X45	27	9,8	4,2	T25
219 TX 03300	5,0X50	30	9,8	4,2	T25
219 TX 03310	5,0X60	35	9,8	4,2	T25
219 TX 03320	5,0X70	42	9,8	4,2	T25
219 TX 03330	5,0X80	50	9,8	4,2	T25
219 TX 03340	5,0X90	50	9,8	4,2	T25
219 TX 03350	5,0X100	50	9,8	4,2	T25
219 TX 03360	5,0X120	70	9,8	4,2	T25
219 TX 03370	6,0X70	42	11,8	5,2	T30
219 TX 03380	6,0X80	50	11,8	5,2	T30
219 TX 03390	6,0X100	50	11,8	5,2	T30
219 TX 03400	6,0X120	70	11,8	5,2	T30
219 TX 03410	6,0X140	70	11,8	5,2	T30
219 TX 03420	6,0X160	70	11,8	5,2	T30
219 TX 03430	6,0X180	70	11,8	5,2	T30
219 TX 03440	6,0X200	70	11,8	5,2	T30
219 TX 03450	6,0X220	70	11,8	5,2	T30
219 TX 03460	6,0X240	70	11,8	5,2	T30
219 TX 03470	6,0X260	70	11,8	5,2	T30
219 TX 03480	6,0X280	70	11,8	5,2	T30
219 TX 03490	6,0X300	70	11,8	5,2	T30
219 TX 03500	8,0X80	50	14,8	7,2	T40
219 TX 03510	8,0X100	50	14,8	7,2	T40
219 TX 03520	8,0X120	80	14,8	7,2	T40
219 TX 03530	8,0X140	80	14,8	7,2	T40
219 TX 03540	8,0X160	80	14,8	7,2	T40
219 TX 03550	8,0X180	80	14,8	7,2	T40
219 TX 03560	8,0X200	80	14,8	7,2	T40
219 TX 03570	8,0X220	80	14,8	7,2	T40
219 TX 03580	8,0X240	80	14,8	7,2	T40
219 TX 03590	8,0X260	80	14,8	7,2	T40
219 TX 03600	8,0X280	80	14,8	7,2	T40
219 TX 03610	8,0X300	80	14,8	7,2	T40
219 TX 03620	8,0X320	80	14,8	7,2	T40
219 TX 03630	8,0X340	80	14,8	7,2	T40
219 TX 03640	8,0X360	80	14,8	7,2	T40
219 TX 03650	8,0X380	80	14,8	7,2	T40
219 TX 03660	8,0X400	80	14,8	7,2	T40
219 TX 03670	10X120	80	18	8,2	T40
219 TX 03680	10X140	80	18	8,2	T40
219 TX 03690	10X160	80	18	8,2	T40
219 TX 03700	10X180	80	18	8,2	T40
219 TX 03710	10X200	80	18	8,2	T40
219 TX 03720	10X220	80	18	8,2	T40
219 TX 03730	10X240	80	18	8,2	T40
219 TX 03740	10X260	80	18	8,2	T40
219 TX 03750	10X280	80	18	8,2	T40
219 TX 03760	10X300	80	18	8,2	T40
219 TX 03770	10X320	80	18	8,2	T40
219 TX 03780	10X340	80	18	8,2	T40
219 TX 03790	10X360	80	18	8,2	T40
219 TX 03800	10X380	80	18	8,2	T40
219 TX 03810	10X400	80	18	8,2	T40

## Tapping screws Torx galvanized black

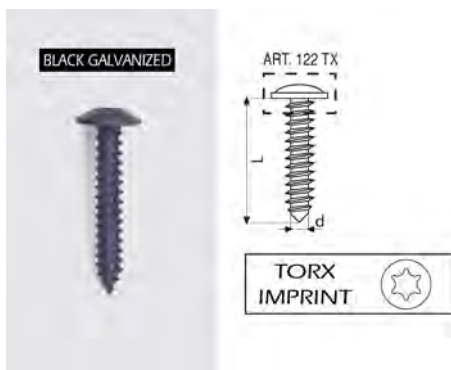

Code	Desc. dxL	Imprint Torx	Type
122TX00040	3,5x16	T 10	DOME HEAD WITH FLANGE
122TX00080	3,5x19	T 10	DOME HEAD WITH FLANGE
122TX00120	3,9x16	T 15	DOME HEAD WITH FLANGE
122TX00160	3,9x19	T 15	DOME HEAD WITH FLANGE
122TX00200	4,2x16	T 20	DOME HEAD WITH FLANGE
122TX00240	4,2x19	T 20	DOME HEAD WITH FLANGE
122TX00280	4,2x25	T 20	DOME HEAD WITH FLANGE
122TX00320	4,8x16	T 20	DOME HEAD WITH FLANGE
122TX00360	4,8x22	T 20	DOME HEAD WITH FLANGE

- Art. 122 TX: self-tapping screw, pan head with flange Torx, galvanized black.

## Tapping screws head mushroom more flange galvanized

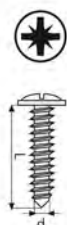

Code	Desc. dxL	Phillips imprint	Type
198ZG00200	3,5x12	PZ 1	GALVANIZED STEEL YELLOW
198ZG00300	3,5x16	PZ 1	GALVANIZED STEEL YELLOW
198ZG00400	4x12	PZ 2	GALVANIZED STEEL YELLOW
198ZG00500	4x14	PZ 2	GALVANIZED STEEL YELLOW
198ZN00540	5x25	PZ 2	GALVANIZED STEEL BLACK

- UNI 9708.
- Double thread for plastic materials.

## Tapping screws hexagon socket head cap

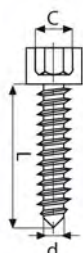

Code	Desc. dxL	Wrench C
1780001400	4,8x13	5
1780001500	4,8x16	5
1780001600	4,8x19	5
1780001700	4,8x22	5
1780001800	4,8x25	5
1780001900	4,8x32	5
1780002000	4,8x38	5
1780002100	4,8x45	5
1780002200	4,8x50	5
1780002250	4,8x60	5
1780002300	5,5x25	5
1780002350	5,5x32	5
1780002360	5,5x38	5
1780002370	5,5x45	5
1780002380	5,5x50	5
1780002400	6,3x32	5
1780002500	6,3x38	5
1780002700	6,3x50	5

- UNI 6947.
- Galvanized white.

## Tapping screws for metal mushroom head with flange galvanized black



Code	Desc. dxL	Phillips imprint
1730000100	3,5x13	PH 2
1730000200	3,5x16	PH 2
1730000300	3,5x19	PH 2
1730000400	3,5x22	PH 2
1730000600	3,9x13	PH 2
1730000700	3,9x16	PH 2
1730000800	3,9x19	PH 2
1730000900	3,9x22	PH 2
1730001000	3,9x25	PH 2
1730001100	4,2x13	PH 2
1730001200	4,2x16	PH 2
1730001300	4,2x19	PH 2
1730001400	4,2x22	PH 2
1730001500	4,2x25	PH 2
1730001800	4,8x19	PH 2
1730002000	4,8x25	PH 2

- Mushroom head with flange Phillips.

2

## Coach screws stainless A2

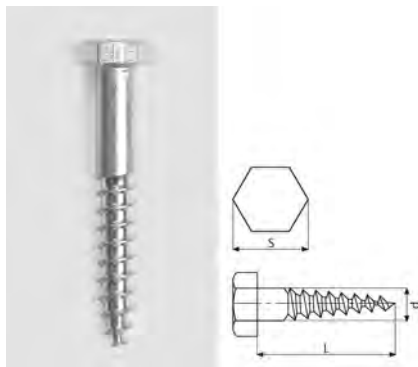

Code	Desc. dxL
197A200030	6x30
197A200040	6x50
197A200050	6x60
197A200055	6x70
197A200085	8x50
197A200086	8x60
197A200088	8x80
197A200090	8x90
197A200096	10x50
197A200098	10x70
197A200100	10x80
197A200200	10x120

- AISI 304
- UNI 704 - DIN 571

## Coach screws galvanized

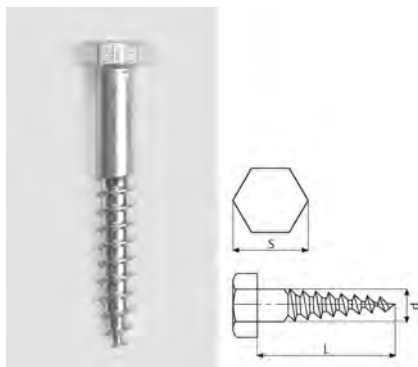

Code	Desc. dxL	Mis. Key S
1970000100	6x30	10
1970000150	6x35	10
1970000200	6x40	10
1970000250	6x45	10
1970000300	6x50	10
1970000350	6x60	10
1970000400	6x70	10
1970000450	6x80	10
1970000670	6x170	10
1970000700	8x40	13
1970000750	8x45	13
1970000800	8x50	13
1970000850	8x60	13
1970000900	8x70	13
1970000950	8x80	13
1970001000	8x130	13
1970001200	10x50	17
1970001250	10x60	17
1970001300	10x70	17
1970001350	10x80	17
1970001400	10x90	17
1970001450	10x100	17
1970001500	10x140	17
1970001600	12x50	19
1970001610	12x60	19
1970001620	12x70	19
1970001630	12x80	19
1970001640	12x90	19
1970001650	12x100	19
1970001660	12x120	19
1970001670	12x140	19
1970001730	14x100	22
1970001740	14x120	22
1970001750	14x140	22

- Strength class 4.8.
- UNI 704 - DIN 571



## Assorted screws stainless A2 TC +



- Contents: 18 sizes of screws TC + steel DIN 7981-A2 by 2,9x9,5 to 2,9x25, 3,5x13 from a 3,5x22, 3,9x16 from a 3,9x22, 4,2x16 from a 4,2x22 + 4,8x25 + 5,5x32 + 6.3 x32.
- Total 837 pieces.
- Supplied in a plastic carrying case n / s cod. 398 00 01800 201.

2

Code	Desc.
1570200100	18

Content kit

CODE	DESCRIPTION	PCS
157 00 01100	4.2X19	50
157 00 01200	4.2X22	25
157 00 01705	4.8X25	25
157 00 01760	5.5X32	25
157 00 02000	6.3X32	12
157 00 00050	2.9X9.5	100
157 00 00070	2.9X13	50
157 00 00100	2.9X16	50
157 00 00140	2.9X19	50
157 00 00200	2.9X25	50
157 00 00400	3.5X13	50
157 00 00500	3.5X16	50
157 00 00600	3.5X19	50
157 00 00620	3.5X22	50
157 00 00700	3.9X16	50
157 00 00800	3.9X19	50
157 00 00900	3.9X22	50
157 00 01000	4.2X16	50

## Assorted screws TC + galvanized



- Contents: 18 sizes of screws TC + galvanized DIN 7981 from 2,2x6,5 to 2,2x13, 2,9x16 from a 2,9x25, 3,5x13 from a 3,5x22, 3,9x13 from a 3,9x22, 4 , 2x6,5 to 4,2 x22, 4,8x13 by 4, 8x22 + 5,5x19 + 6,3x16.
- Total 1025 pieces.
- Supplied in a plastic carrying case n / s cod. 398 00 01800 201.

Code	Desc.
1580100200	18

Content kit

CODE	DESCRIPTION	PCS
158 00 00200	2.2X6.5	100
158 00 00400	2.2X13	100
158 00 00900	2.9X16	100
158 00 01200	2.9X25	100
158 00 01800	3.5X19	50
158 00 01600	3.5X13	50
158 00 01900	3.5X22	50
158 00 02600	3.9X16	50
158 00 02800	3.9X22	50
158 00 03200	4.2X6.5	50
158 00 03400	4.2X13	50
158 00 03500	4.2X16	50
158 00 04300	4.8X13	50
158 00 04600	4.8X22	20
158 00 05400	5.5X19	20
158 00 06200	6.3X16	25
158 00 02500	3.9X13	50
158 00 03700	4.2X22	50

2

## Assorted screws TPS + galvanized



- Contents: 12 screw sizes TPS + galvanized DIN 7982 from a 2,9x22 2,9x16, 3,5x13 from a 3,5x25, 3,9x16 from a 3,9x19, 4,2x13 from a 4,2x25 + 4,8x19.
- Total 650 pieces.
- Supplied in a plastic carrying case n / s cod. 398 00 01700 200.

Code	Desc.
1640100200	12

### Contenuto kit

CODICE	DESCRIZIONE	Q.tà
164 00 00100	2.9X16 VIT.AUT.TPS+ZINC.7982	100
164 00 00150	2.9X19 VIT.AUT.TPS+ZINC.7982	100
164 00 00200	2.9X22 VIT.AUT.TPS+ZINC.7982	50
164 00 00300	3.5X13 VIT.AUT.TPS+ZINC.7982	50
164 00 00510	3.5X25 VIT.AUT.TPS+ZINC.7982	50
164 00 00600	3.9X19 VIT.AUT.TPS+ZINC.7982	50
164 00 00700	4.2X13 VIT.AUT.TPS+ZINC.7982	50
159 00 03700	4.8X13 VIT.AUT.TGS+ZINC.7983	50
159 00 03900	4.8X19 VIT.AUT.TGS+ZINC.7983	25
159 00 05000	5.5X25 VIT.AUT.TGS+ZINC.7983	25
159 00 05600	6.3X22 VIT.AUT.TGS+ZINC.7983	50
159 00 05050	5.5X32 VIT.AUT.TGS+ZINC.7983	50

## Assorted screws TC + galvanized black



- Contents: 18 measures galvanized screws TC + black to DIN 7981 from 2,9x13 2,9x19, 3,5x13 from a 3,5x25, 3,9x16 from a 3,9x32, 4,2x13 from a 4,2x25, from 4,8x13 in 4,8x32.
- Total 740 pieces.
- Supplied in a plastic carrying case n / s cod. 398 00 01800 201.

Code	Desc.
1690100200	18

### Contenuto kit

CODICE	DESCRIZIONE	Q.tà
169 00 00200	2.9X13 -VITE AUT.TC+ZINC.NERA	100
169 00 00300	2.9X16 -VITE AUT.TC+ZINC.NERA	100
169 00 00400	2.9X19 -VITE AUT.TC+ZINC.NERA	40
169 00 00500	3.5X13 -VITE AUT.TC+ZINC.NERA	40
169 00 00700	3.5X16 -VITE AUT.TC+ZINC.NERA	40
169 00 01000	3.5X25 -VITE AUT.TC+ZINC.NERA	30
169 00 01300	3.9X16 -VITE AUT.TC+ZINC.NERA	30
169 00 01400	3.9X19 -VITE AUT.TC+ZINC.NERA	30
169 00 01570	3.9X32 -VITE AUT.TC+ZINC.NERA	30
169 00 01600	4.2X13 -VITE AUT.TC+ZINC.NERA	30
169 00 01800	4.2X19 -VITE AUT.TC+ZINC.NERA	30
169 00 01900	4.2X22 -VITE AUT.TC+ZINC.NERA	30
169 00 02000	4.2X25 -VITE AUT.TC+ZINC.NERA	30
169 00 02030	4.8X16 -VITE AUT.TC+ZINC.NERA	30
169 00 02035	4.8X19 -VITE AUT.TC+ZINC.NERA	30
169 00 02040	4.8X22 -VITE AUT.TC+ZINC.NERA	30
169 00 02070	4.8X32 -VITE AUT.TC+ZINC.NERA	20
169 00 02025	4.8X13 -VITE AUT.TC+ZINC.NERA	30

## Drilling screws cylindrical head cross

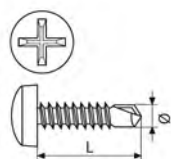

- UNI 8118.
- PH imprint

Code	Description	Measures (mm)
23300*****	GALVANIZED WHITE	SEE PRICE LIST
2332N*****	GALVANIZED BLACK	SEE PRICE LIST

## Self-tapping screws countersunk head cross

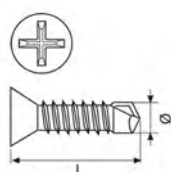

- UNI 8119
- PH imprint

Code	Description	Measures (mm)
23400*****	GALVANIZED WHITE	SEE PRICE LIST
2342N*****	GALVANIZED BLACK	SEE PRICE LIST

## Screws for wooden platforms



- Self-drilling screws countersunk head footprint PH
- With printed wings specific for fixing wood on sheet
- White galvanized finish
- **INDICATED FOR THE FIXING OF FLOORS IN MULTI-LAYER ON STEEL OR ALUMINUM FOR TRAILERS AND SEMI-TRAILERS**

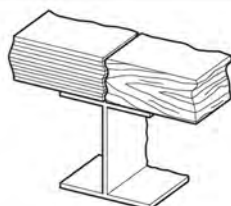

Code	Desc.	Imprint <i>PH</i>	Tigh. thickness. mm
2340001920	4,2X38	2	6-22
2340002720	4,8X55	2	13-35
2340003200	5,5X38	3	6-22
2340003400	5,5X50	3	13-30
2340003420	5,5X60	3	13-40
2340004200	6,3X70	3	13-50

2

## Screws for wooden platforms

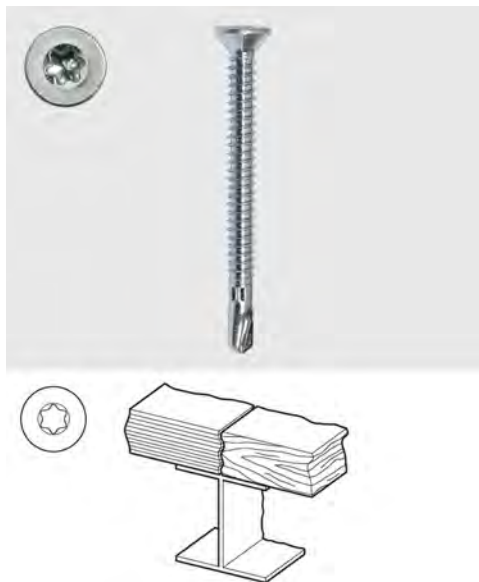

- Torx countersunk self-drilling screws
- With printed wings specific for fixing wood on sheet
- White galvanized finish
- **INDICATED FOR THE FIXING OF FLOORS IN MULTI-LAYER ON STEEL OR ALUMINUM FOR TRAILERS AND SEMI-TRAILERS**

Code	Desc.	Imprint <i>Torx</i>	Tigh. thickness. mm
2340004205	6,3x50	T30	13-30
2340004206	6,3x60	T30	13-40
2340004210	6,3x70	T30	13-50

## Screws for wooden platforms

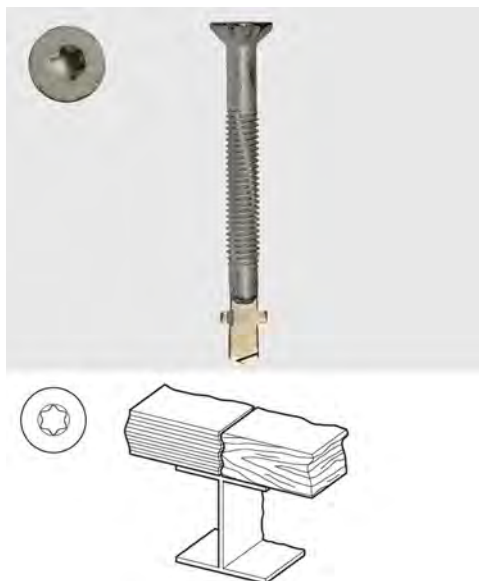

- Self-drilling screws and self-tapping screws with countersunk head - Torx imprint
- With flap indicated for the fixing of wood on sheet metal
- Galvanized-passivated white finish
- **INDICATED FOR THE FIXING OF FLOORS IN MULTI-LAYER ON STEEL OR ALUMINUM FOR TRAILERS AND SEMI-TRAILERS**

Code	Desc.	Imprint <i>PH</i>	Tigh. thickness. mm
2340004220	8x70	T40	35
2340004230	8x85	T40	50

## Drilling screws Round head flange screwdriver galvanized



- Ideal for fixing the holder to the bodywork.
- Flanged low head screws.

Code	Desc. dxL	Phillips imprint	Type
2390000150	4,2x13	PH 2	GALVANIZED WHITE
2390000160	4,2x16	PH 2	GALVANIZED WHITE
2390000170	4,2x19	PH 2	GALVANIZED WHITE
2390000190	4,2x25	PH 2	GALVANIZED WHITE
2390000200	4,2x32	PH 2	GALVANIZED WHITE
2390000210	4,2x38	PH 2	GALVANIZED WHITE
2390000230	4,8x16	PH 2	GALVANIZED WHITE
2390000240	4,8x19	PH 2	GALVANIZED WHITE
2390000260	4,8x25	PH 2	GALVANIZED WHITE
2390000280	4,8x38	PH 2	GALVANIZED WHITE
2390000310	4,8x50	PH 2	GALVANIZED WHITE
2390000340	4,8x80	PH 2	GALVANIZED WHITE



## Drilling screws Hex Head

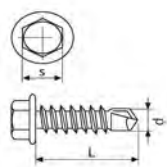

- Galvanized white.
- UNI 8117.

Code	Description
24000*****	see price list

Ø SCREW	3,5	3,9	4,2	4,8	5,5	6,3
KEY mm	5,5	5,5	7	8	8	10

## Drilling screws cylindrical head Torx Plus



- Galvanized steel screws white.
- Ideal for all kinds of hardware with maximum grip.
- Torx imprint.
- To be used with our 443 00-bit 46753 (t15) - 443 00 46 755 (t20) - 443 00 46 757 (t25).

Code	Ø screw mm	Length mm	Imprint Torx
233TX02000	3,5	13	T15
233TX02010	3,5	16	T15
233TX02020	3,5	19	T15
233TX02030	3,5	22	T15
233TX02040	3,5	25	T15
233TX02050	3,9	13	T15
233TX02000	3,9	16	T15
233TX02070	3,9	19	T15
233TX02080	3,9	22	T15
233TX02090	3,9	25	T15
233TX02100	3,9	32	T15
233TX02110	4,2	13	T20
233TX02120	4,2	16	T20
233TX02130	4,2	19	T20
233TX02140	4,2	22	T20
233TX02160	4,2	32	T20
233TX02170	4,2	38	T20
233TX02180	4,2	45	T20
233TX02190	4,2	50	T20
233TX02200	4,8	16	T25
233TX02210	4,8	19	T25
233TX02220	4,8	22	T25
233TX02230	4,8	25	T25
233TX02240	4,8	32	T25
233TX02250	4,8	38	T25
233TX02260	4,8	45	T25
233TX02270	4,8	50	T25
233TX02280	4,8	60	T25
233TX02290	5,5	25	T25
233TX02300	5,5	32	T25
233TX02310	5,5	38	T25
233TX02320	5,5	45	T25
233TX02330	5,5	50	T25
233TX02340	5,5	60	T25
233TX02350	5,5	70	T25
233TX02360	5,5	80	T25

## Drilling screws countersunk flat head Torx Plus

2



- Galvanized steel screws white.
- Ideal for fixing of every kind with maximum grip.
- Torx imprint.
- To be used with our 443 00-bit 46753 (t15) - 443 00 46 755 (t20) - 443 00 46 757 (t25).

Code	Ø screw mm	Length mm	Imprint Torx
234TX01000	3,5	13	T15
234TX01010	3,5	16	T15
234TX01020	3,5	19	T15
234TX01030	3,5	22	T15
234TX01040	3,5	25	T15
234TX01050	3,9	16	T15
234TX01060	3,9	19	T15
234TX01070	3,9	22	T15
234TX01080	3,9	25	T15
234TX01090	3,9	32	T15
234TX01100	4,2	16	T20
234TX01120	4,2	22	T20
234TX01130	4,2	25	T20
234TX01140	4,2	32	T20
234TX01160	4,8	16	T25
234TX01170	4,8	19	T25
234TX01180	4,8	22	T25
234TX01190	4,8	25	T25
234TX01200	4,8	32	T25
234TX01210	4,8	38	T25
234TX01220	4,8	45	T25
234TX01230	4,8	50	T25
234TX01240	5,5	25	T25
234TX01250	5,5	32	T25
234TX01270	5,5	45	T25
234TX01280	5,5	50	T25
234TX01290	5,5	60	T25
234TX01300	5,5	70	T25
234TX01310	5,5	80	T25

## Drilling screws autosvasanti TPG for PVC - For fitting of hinges

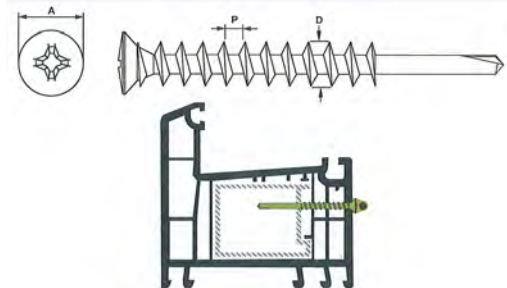

- Special self-tapping screws with countersunk head and tip extra long, designed for direct application on PVC profiles with internal steel reinforcement. Permettono drilling the internal reinforcement before the thread engages the outer PVC.
- Used primarily for the application of supposrti support of the hinges.
- Built with hardened steel C1022, countersunk head slightly radial, PH footprint with increased depth for greater transmission torque, white zinc 8 microns thick, corrosion resistance up to 96 hours in salt spray.

Code	Desc.	P mm	Ø testa mm	Imprint PH
2340005050	4,3X36,5P	2,25	7	2
2340005060	4,3x42,5P	2,25	7	2
2340005070	4,3X47,5P	2,25	7	2

## TSPG tapping screws for PVC - Mounting hardware and meetings

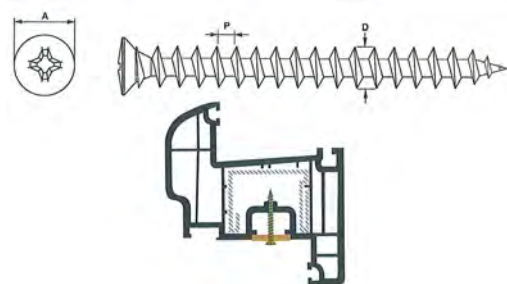

- Tapping screws thread total with special countersunk head slightly radial, specially designed for securing the perimeter hardware and meetings on the profiles of PVC frames.
- Are used directly in the PVC-U, in the sections not internally reinforced, the hollow cross PH is deeper than normal screws and special angle under head allows perfect alignment even if the screw is not perfectly perpendicular.
- Made of tempered steel, galvanized surface 8 microns, tip needle and thread off for easy penetration and a good seal. Corrosion resistance up to 96 hours in salt spray.

Code	Desc.	Useful length mm	Ø testa mm	P mm	Imprint PH
164PV00100	4,3X20	14	7	2,25	2
164PV00110	4,3X22	16	7	2,25	2
164PV00120	4,3X25	19	7	2,25	2
164PV00130	4,3X30	24	7	2,25	2
164PV00140	4,3X35	29	7	2,25	2
164PV00150	4,3X40	34	7	2,25	2
164PV00160	4,3X45	39	7	2,25	2

## TSPG tapping screws for PVC - To restore hardware hardware and meetings

2

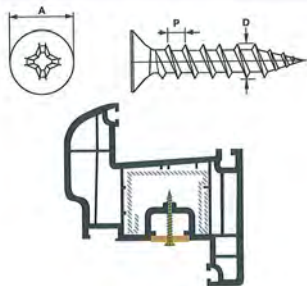

- Screws specific welt total with special countersunk head slightly radial, specially designed for the restoration of the hardware perimeter hardware and meetings on the profiles of PVC window frames, for use on existing holes.
- It is to replace all the screws of diameter 4.3-4.5, type our 164PV, when they are no longer grip on PVC, solving the problem of the torn hole in a simple and fast. The screw has the same characteristics but with a larger diameter that allows the fixing.
- Made of tempered steel, galvanized surface 8 microns, tip needle and thread off for easy penetration and a good seal. Corrosion resistance up to 96 hours in salt spray.
- The screw length of 38 mm has a dual start thread for sealing even greater draw.

Code	Desc.	Useful length mm	Ø testa mm	P mm	Imprint PH
164PV01000	4,8X25	20	7	2,35	2
164PV01010	4,8X38	33	7	3,60 (2P)	2

## Drilling screws autosvasanti TSPG for PVC - For securing reinforcements

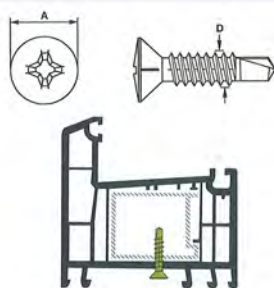
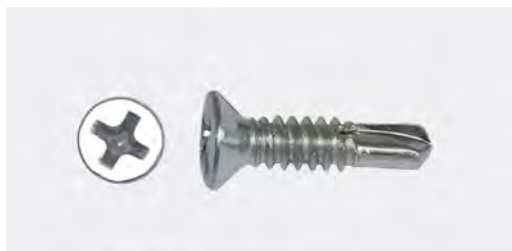

- Special self-tapping screws with countersunk head radiated under head, with autosvasante function and self-locking. Designed for direct application on PVC profiles with internal steel reinforcement.
- Mainly used for the application of hardware, reinforcements, hinges and meetings directly on the profile. The tip in carbon steel allows fast applications without the need for pre-drilling hole, the thread specification allows a perfect hold over time.
- Built with hardened steel C1022, countersunk head slightly radial, PH footprint with increased depth for greater transmission torque, white zinc 8 microns thick, corrosion resistance up to 96 hours in salt spray.

Code	Desc.	Ø testa mm	Imprint PH
2340005000	3,9X14P	7	2
2340005010	3,9X16P	7	2
2340005020	3,9X19P	7	2
2340005110	3,9X25P	7	2
2340005120	3,9X32P	7	2



## Tapping screws A2 stainless steel coppery with sealing washer

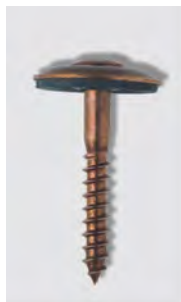

- Tapping screws AUBURN ideal for the installation of copper gutters and flashings.
- Body in stainless steel A2.
- Large washer with vulcanized rubber seal that allows the seal to avoid the infiltration of water into the holders.
- \* Washer with vulcanized seal  $\varnothing$  20 mm.

Code	Desc. <i>Measures</i>	Pozdriv imprint
155CU00300	4,5x35	PZ 2
155CU00400	4,5x45	PZ 2

## Drywall screws



- Special screws for plasterboard.
- Nail tip, double thread.
- Flat countersunk head, phillips cross mark.
- Black phosphates.

Code	Desc. <i>Measures</i>	Phillips imprint
2180000025	3,5x25	PH 1
2180000035	3,5x35	PH 1
2180000045	3,5x45	PH 1
2180000075	4,2x80	PH 2

## Flat head self tapping screws countersunk hole for insertion cap imprint PZ



- Material galvanized steel white.
- Bits PZ2 use.
- Hole in the head of the screw inserting plastic cap 219TP....
- Particular thread polyvalent for various applications.
- Use for chipboard, with nylon plugs and aluminum.

Code	Desc.	Imprint <i>PZ</i>
219ZB00050	4,5X30	2
219ZB00100	4,5X40	2
219ZB00150	4,5X50	2
219ZB00200	4,5X60	2
219ZB00250	4,5X70	2
219ZB00300	5X40	2
219ZB00350	5X50	2
219ZB00400	5X60	2
219ZB00450	5X70	2
219ZB00500	5X90	2

## Colored plastic caps

- Colored plastic material.
- plugs screws 219ZB ...
- Possibility of 5 different colors.
- Maximum grip in the screw head as the hole.
- Universal for measuring 4.5 and 5 mm.



Code	Description
219TP00050	WHITE
219TP00100	BLACK
219TP00150	GREY
219TP00200	LIGHT BROWN
219TP00250	DARK BROWN

## Self-tapping screws for building

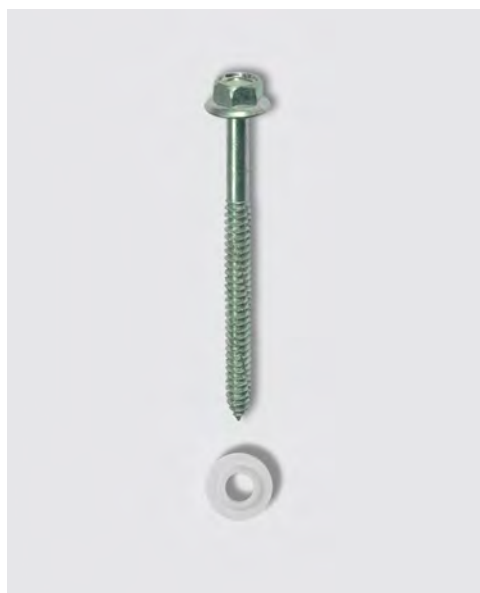

- K10 hexagonal collar cable  $\varnothing$  14.5 mm for optional housing sealing washers n / s art. 242 00 00150 / RON.
- BS thread tapping and self-tapping for the use of thick layers without prior tapping.
- Points to 45 ° for assembly with pre-hole.

Code	Desc. <i>Measures</i>	Wrench mm
2380000100	6,3x20	10
2380000200	6,3x35	10
2380000300	6,3x50	10
2380000400	6,3x60	10
2380000500	6,3x80	10
2380000600	6,3x100	10
2380000700	6,3x120	10
2420000150	RON*	-

## Screws shallow head drilling and tapping



- Material galvanized steel and white steel A2.
- Ideal for attaching accessories in aluminum frames.
- Also ideal for plastic gutters, since the advantage of the ultra head lowered.
- Indicated in all applications where the head needs to have the minimum protrusion.
- Footprint Philips PH2.

Code	Desc.	Insert	Finishing	Type
164TB00100	4.2X13	PH2	WHITE	TAPPING GALVANIZED
164TB00300	4.2X22	PH2	WHITE	TAPPING GALVANIZED
164TB00500	4.2X32	PH2	WHITE	TAPPING GALVANIZED
234TB00200	4.2X14	PH2	WHITE	SELF DRILLING GALVANIZED
234TB00400	4.2X23	PH2	WHITE	SELF DRILLING GALVANIZED
164A200100	4.2X13	PH2	WHITE	TAPPING. A2
164A200300	4.2X22	PH2	WHITE	TAPPING. A2
164A200500	4.2X32	PH2	WHITE	TAPPING. A2

## Tapping screws countersunk flat head Torx conical

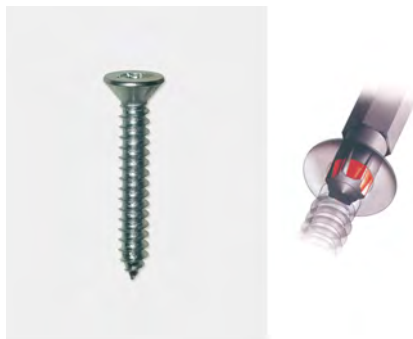

Code	Leng. mm	Spess. testa mm	Ø testa	Ø screw mm	Cod. bits
164TX00050	9,5	3,1	7	3,5	4430050990
164TX00100	13	3,1	7	3,5	4430050990
164TX00150	16	3,1	7	3,5	4430050990
164TX00200	19	3,1	7	3,5	4430050990
164TX00250	13	3,6	8	4,2	4430051000
164TX00300	16	3,6	8	4,2	4430051000
164TX00350	19	3,6	8	4,2	4430051000
164TX00400	25	3,6	8	4,2	4430051000
164TX00450	32	3,6	8	4,2	4430051000
164TX00500	19	3,7	9,5	4,8	4430051000
164TX00550	25	3,7	9,5	4,8	4430051000
164TX00600	32	3,7	9,5	4,8	4430051000
164TX00650	38	3,7	9,5	4,8	4430051000

- Material galvanized steel white.
- Ideal for all kinds of hardware with maximum grip.
- Imprint Torx conical.
- Screws to be used exclusively with the bits indicated.

## Appropriate bits to hex screw 1/4 (6.35) Torx More

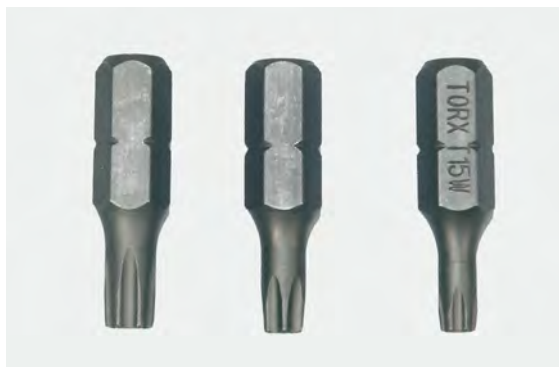

- Imprint Torx male.

Code	Desc.	Length mm
4430046753	749 P-TX15	25
4430046755	749 P-TX20	25
4430046757	749 P-TX25	25
4430058090	749 P-TX30	25
4430000220	P-TX15L	50
4430000230	P-TX20L	50
4430000240	P-TX25L	50

## Drilling screws for building



\* RONDELLA DI TENUTA DA ORDINARE A PARTE

- K10 hexagonal collar cable ø 14.5 mm for housing washer.
- Bs tapping and self-tapping thread for use on thick layers without prior tapping.
- Drill point right to drill thicknesses up to 5 mm, and screw thread consecutively.

Code	Desc. Measures	Wrench mm
2420000020	6,3x20	10
2420000025	6,3x25	10
2420000035	6,3x35	10
2420000040	6,3x40	10
2420000050	6,3x50	10
2420000070	6,3x70	10
2420000080	6,3x80	10
2420000100	6,3x100	10
2420000120	6,3x120	10
2420000150	RON*	

2

## Drilling screws with mock washer



- Self-tapping screws with cylindrical head extra low and pretend washer.
- Ideal for fixing of thin sheet metal and of plastic material on metal constructions.
- The pretend washer distributes the effort on a wider surface avoiding any surface damage fixed.
- Head Cross recessed Phillips.

Code	Desc. <i>Measures</i>	D <i>mm</i>	K <i>mm</i>	Phillips imprint
1140000020	4,2x13	11	1,9x2,5	PH 2
1140000030	4,2x16	11	1,9x2,5	PH 2
1140000040	4,2x19	11	1,9x2,5	PH 2
1140000070	4,8x32	12,5	1,9x2,5	PH 2
1140000080	4,8x32	12,5	1,9x2,5	PH 2
1140000100	4,8x40	12,5	1,9x2,5	PH 2
1140000200	4,8x45	12,5	1,9x2,5	PH 2
1140000300	4,8x50	12,5	12,5	PH 2
1140000400	4,8x60	12,5	1,9x2,5	PH 2
1140000500	4,8x70	12,5	1,9x2,5	PH 3
1140000600	4,8x80	12,5	1,9x2,5	PH 2

## Drilling screws Round head flange, conical Torx



- Material galvanized steel white.
- Ideal for mounting on overhead sheets, covers, etc.
- Imprint Torx conical.
- Screws to be used exclusively with the bits indicated.

Code	Leng. <i>mm</i>	Spess. testa mm	Ø testa	Ø screw <i>mm</i>	Cod. <i>bits</i>
239TX00050	13	2,6	11	4,2	4430051000
239TX00100	16	2,6	11	4,2	4430051000
239TX00150	19	2,6	11	4,2	4430051000
239TX00200	25	2,6	11	4,2	4430051000



## Drilling screws with hexagonal rubber washer, roofing



- Material galvanized steel white.
- Self drilling.
- Complete sealing washers with rubber and not.
- Ideal for roofing.
- Threaded part 60 mm for all sizes.

2

Code	Desc. dxL	Description	Wrench	FIL. XL.	Type
114CR00100	6,3x60	-	10	60x60	WITH WASHER
114CR00300	6,3x110	-	10	60x110	WITH WASHER
114ZB00200	-	6,3x80 TEK SCREW ZB	10	6.3X80	WITHOUT WASHER
114ZB00300	-	6,3x110 TEK SCREW ZB	10	6.3X110	WITHOUT WASHER
114ZB00400	-	6,3x120 TEK SCREW ZB	10	6.3X120	WITHOUT WASHER

## Colored plastic caps for all screws Round head diameter 4.8 mm



- Colored plastic material.
- Caps for cylindrical head screws d. 4.8 mm.
- Available colors black and white.

Code	Description
219TP00300	TC-WHITE
219TP00350	TC-BLACK

## Washers with rubber

- Steel and rubber.



Code	Description
245CG00100	6,3 - SEALED WASHERS

2

## Seals O-Ring NBR 70 Black color



- Available in a wide range of metric and English.
- Special rubber resistant to oils.

Code	Desc.	Di mm	DE mm	SPE mm
41400****	****	****	****	****

## O-Rings assortment



- Content: 16 measures of O-ring 010 to 150
- Total 1050 pieces
- Supplied in a plastic carrying case our cod. 398 00 01900 abh4

Code	Desc.
4140300100	16

### Content kit

CODE	DESCRIPTION	PCS
414 00 00100	010 -2.9X6.46X1.78	100
414 00 00200	020 -3.69X7.25X1.78	100
414 00 00250	030 -4.48X8.04X1.78	100
414 00 00300	040 -5.28X8.84X1.78	100
414 00 00400	050 -6.07X9.63X1.78	100
414 00 00500	060 -6.75X10.31X1.78	50
414 00 00600	070 -7.66X11.22X1.78	50
414 00 00700	080 -8.73X12.29X1.78	50
414 00 00800	090 -9.13X14.37X2.62	50
414 00 00900	100 -9.25X12.81X1.78	50
414 00 00950	110 -9.19X14.43X2.62	50
414 00 01000	120 -9.92X15.16X2.62	50
414 00 01100	130 -10.78X16.02X2.62	50
414 00 01200	135 -10.82X14.38X1.78	50
414 00 01300	140 -11.11X14.67X1.78	50
414 00 01400	150 -11.91X17.15X2.62	50

## Kit o-ring case



- Carrying case with slots N° 32 positions of O-rings Assorted
- N° 407 pieces.

2

Code	Desc.
4140300700	41900

### Content kit

CODE	DESCR.	Dimens.	PCS	CODE	DESCR.	Dimens.	PCS
414 00 00100	10	2,9x1,78	20	414 00 02900	260	20,22x3,53	10
414 00 00250	30	4,47x1,78	20	414 00 03300	290	21,82x3,53	10
414 00 00400	50	6,07x1,78	20	414 00 03600	310	23,39x3,53	10
414 00 00600	70	7,66x1,78	20	414 00 03900	330	24,99x3,53	10
414 00 00900	100	9,25x1,78	20	414 00 04100	350	26,57x3,53	10
414 00 01600	165	12,42x1,78	20	414 00 04300	360	28,17x3,53	10
414 00 00950	110	9,49x2,62	13	414 00 04500	370	29,74x3,53	10
414 00 01100	130	10,77x2,62	13	414 00 04550	380	31,34x3,53	10
414 00 01500	160	12,37x2,62	13	414 00 04700	390	32,92x3,53	10
414 00 01800	180	13,94x2,62	13	414 00 04800	400	34,52x3,53	10
414 00 02100	200	15,54x2,62	13	414 00 05000	410	36,09x3,53	10
414 00 02300	220	17,13x2,62	13	414 00 05100	420	37,69x3,53	10
414 00 02600	240	17,72x2,62	13	414 00 05600	460	41,28x3,53	10
414 00 03000	270	20,24x2,62	13	414 00 06000	490	44,45x3,53	10
414 00 03500	300	22,22x2,62	13	414 00 06300	512	47,22x3,53	10
414 00 02700	250	18,64x3,53	10	414 00 06600	530	50,39x3,53	10

## Rope NBR 70 O-Ring



- Rope compound NBR70 black color.
- "Rubber-oil" for the realization of sealing rings to measure.
- For the union to use our art. Aderfix **gasket** cod. 411 00 15125 to 2854

Code	Desc. Ø mm
4150000100	1,78
4150000200	2,00
4150000300	2,62
4150000400	3,00
4150000500	3,53
4150000600	4,00
4150000800	5,00
4150000900	5,34

2

## Radial retaining ring

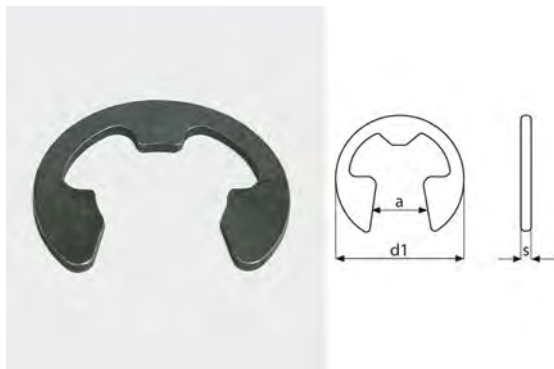

Code	Desc. Ø nominal	d1 mm.	a mm	s mm
2890000200	1.5	3,9	1,28	0,4
2890000300	1.9	4,4	1,61	0,5
2890000500	2.3	5,9	1,94	0,6
2890000700	3.2	6,85	2,7	0,6
2890000800	4	8,85	3,34	0,7
2890000900	5	10,85	4,11	0,7
2890001000	6	11,85	5,26	0,7
2890001100	7	13,8	5,84	0,9
2890001200	8	15,8	6,52	1
2890001300	9	18,3	7,63	1,1
2890001400	10	19,8	8,32	1,2
2890001500	12	22,7	10,45	1,3
2890001600	15	28,7	12,61	1,5
2890001700	19	36,6	15,92	1,75
2890001800	24	43,6	21,88	2

- Stop rings radial of spring steel, hardened and tempered.
- Treated with antioxidant burnishing.
- DIN 6799 UNI 7434.

## Assortment stop rings radial



- Content: 12 measures the stop rings din 6799 from 2.3 to 19.
- Total 572 pieces.
- supplied in plastic carrying case n / s cod. 398 00 01700 200.

Code	Desc.
2890100200	12

### Content kit

CODE	DESCRIPTION	PCS
289 00 00500	2.3	100
289 00 00700	3.2	100
289 00 00800	4	25
289 00 00900	5	25
289 00 01000	6	25
289 00 01100	7	50
289 00 01200	8	50
289 00 01300	9	50
289 00 01400	10	25
289 00 01500	12	25
289 00 01600	15	10
289 00 01700	19	10
398 00 01700	200	1
ETI 00 0024A	EXTERNAL LABEL	1
ETI 00 0024B	INTERNAL LABEL	1



## Washers for shafts without groove



Code	Desc. Ø shaft
2640000100	2
2640000200	2,5
2640000300	3
2640000400	4
2640000500	5
2640000600	6
2640000700	7
2640000800	8
2640000900	9
2640001000	10

- Washers manufactured with spring steel c60 burnished.

## External stop rings

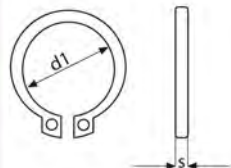

Code	Desc. Ø nominal	d1 mm.	s mm
2620000100	5	4,7	0,6
2620000200	6	5,6	0,7
2620000300	7	6,5	0,8
2620000400	8	7,4	0,8
2620000500	9	8,4	1
2620000600	10	9,3	1
2620000700	11	10,2	1
2620000800	12	11	1
2620000900	13	11,9	1
2620001000	14	12,9	1
2620001100	15	13,8	1
2620001200	16	14,7	1
2620001300	17	15,7	1
2620001400	18	16,5	1,2
2620001500	19	17,5	1,2
2620001600	20	18,5	1,2
2620001700	21	19,5	1,2
2620001800	22	20,5	1,2
2620001900	23	21,5	1,2
2620002000	24	22,2	1,2
2620002100	25	23,2	1,2
2620002200	26	24,2	1,2
2620002300	27	24,9	1,2
2620002400	28	25,9	1,5
2620002500	29	26,9	1,5
2620002600	30	27,9	1,5
2620002700	31	28,6	1,5
2620002800	32	29,6	1,5
2620002900	33	30,5	1,5
2620003000	34	31,5	1,5
2620003100	35	32,2	1,5
2620003110	37	34,2	1,75
2620003140	40	36,5	1,75
2620003200	45	41,5	1,75
2620003300	48	44,5	1,75
2620003400	50	45,8	2
2620003500	55	50,8	2
2620003600	58	53,8	2
2620003700	60	55,8	2

- Stop rings radial spring steel, hardened and tempered.
- Treated with antioxidant burnishing.
- DIN 471 UNI 7435.

## Inside stop rings

2



- Stop rings made of spring steel, hardened and tempered.
- Treated with antioxidant burnishing.
- DIN 472 UNI 7437.

Code	Desc. Ø nominal	d1 mm.	s mm
2630000100	8	8,7	0,8
2630000200	9	9,8	0,8
2630000300	10	10,8	1
2630000400	11	11,8	1
2630000500	12	13	1
2630000600	13	14,1	1
2630000700	14	15,1	1
2630000800	15	16,2	1
2630000900	16	17,3	1
2630001000	17	18,3	1
2630001100	18	19,5	1
2630001200	19	20,5	1
2630001300	20	21,5	1
2630001400	21	22,5	1
2630001500	22	23,5	1
2630001600	23	24,6	1,2
2630001700	24	25,9	1,2
2630001800	25	26,9	1,2
2630001900	26	27,9	1,2
2630002000	27	29,1	1,2
2630002100	28	30,1	1,2
2630002200	29	31,1	1,2
2630002300	30	32,1	1,2
2630002470	34	36,5	1,5
2630002480	36	38,8	1,5
2630002500	37	39,8	1,5
2630002590	45	48,5	1,75
2630002600	46	49,5	1,75
2630002620	50	54,2	2
2630002800	65	69,2	2,5
2630003000	75	79,5	2,5

## Assortment external seeger rings



- Content: 18 measures external seeger rings DIN 471 from 5 to 25.
- Total 660 pieces.
- Supplied in a plastic carrying case our cod. 398 00 01800 201.

Code	Desc.
2620100200	18

### Content kit

CODE	DESCRIPTION	PCS
262 00 00100	5	50
262 00 00200	6	50
262 00 00300	7	50
262 00 00400	8	50
262 00 00600	10	50
262 00 00700	11	50
262 00 00800	12	50
262 00 00900	13	50
262 00 01000	14	50
262 00 01100	15	25
262 00 01200	16	25
262 00 01300	17	25
262 00 01400	18	25
262 00 01500	19	25
262 00 01700	21	25
262 00 01800	22	25
262 00 01900	23	25
262 00 02100	25	15

## Assortment seeger rings interior



- Contents: 18 measures of internal seeger rings DIN 472 for 8 to 25.
- Total 655 pieces.
- Supplied in a plastic carrying case our cod. 398 00 01800 201.

2

Code	Desc.
2630100200	18

### Content kit

CODE	DESCRIPTION	PCS
263 00 00100	8	50
263 00 00200	9	50
263 00 00300	10	50
263 00 00400	11	50
263 00 00500	12	50
263 00 00600	13	50
263 00 00700	14	50
263 00 00800	15	50
263 00 00900	16	50
263 00 01000	17	50
263 00 01100	18	25
263 00 01200	19	25
263 00 01300	20	25
263 00 01400	21	25
263 00 01500	22	25
263 00 01600	23	10
263 00 01700	24	10
263 00 01800	25	10

## Uni 1336 pins - Din 94 - Iron annealed



- Pins iron annealed.
- The nominal diameter of the pins, to the Convention on the diameter of the hole.

Code	Dimension d x L
2820000200	1x40
2820000400	1,5x40
2820000500	2x40
2820000550	2x50
2820000600	2,5x40
2820000650	2,5x50
2820000700	2,5x60
2820000800	3x50
2820000900	3x60
2820001100	3,5x50
2820001200	3,5x60
2820001400	4x40
2820001500	4x50
2820001550	4x60
2820001600	4x70
2820001700	4,5x50
2820001800	5x40
2820002000	5x50
2820002100	5x70
2820002400	6x50
2820002500	6x60
2820002600	6x90
2820002900	7x80
2820003200	8x60
2820003300	8x80
2820003400	8x100
2820003600	10x100

## Uni 1336 pins - Din 94 - A2 stainless steel

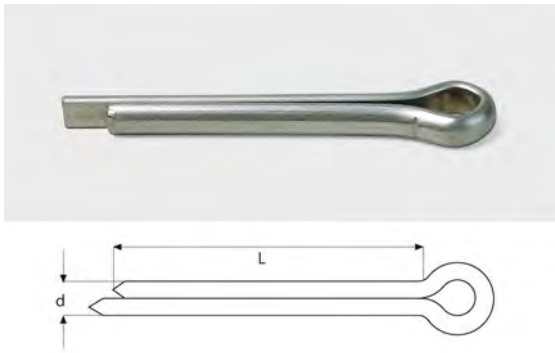

Code	Dimension d x L
286A200100	1x15
286A200150	1,5x15
286A200200	1,5x25
286A200300	1,5x30
286A200400	2x40
286A200500	2,5x40
286A200600	3x40
286A200900	4x60
286A201100	5x60
286A201200	6x40
286A201300	6x60

- Cotter pins steel A2
- The nominal diameter of the pins is, by convention, the relative diameter of the through hole

## Assortment cotter pins



- Contents: 12 measures annealed pins 1x40 to 6x90.
- Total 750 pieces.
- Supplied in plastic case our cod. 398 00 01900 ABH4.

Code	Desc.
2820100100	12

### Content kit

CODE	DESCRIPTION	PCS
282 00 00200	1X40	100
282 00 00550	2X50	100
282 00 01200	3.5X60	50
282 00 01500	4X50	50
282 00 01700	4.5X50	50
282 00 02000	5X50	50
282 00 02100	5X70	25
282 00 02400	6X50	25
282 00 02600	6X90	12
282 00 00650	2.5X50	12
282 00 00400	1.5X40	90
282 00 00900	3X60	50



## Shaped pins



Code	Desc. <i>d</i>
2310000100	2
2310000200	3
2310000250	3,5
2310000300	4
2310000400	5
2310000500	6

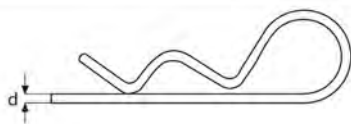

- Galvanized.
- Application of agricultural machinery.
- Type of material: galvanized steel.

## Cotter pins shaped double row



Code	Desc. <i>d</i>
231DG00100	3
231DG00300	4
231DG00500	5
231DG00700	6



- Fully galvanized steel.
- Applications of agricultural machinery.

2

## Assorted shaped pins



- Contents: 6 sizes of pins shaped diam. 2 in diameter. 6.
- Total 130 pieces.
- Supplied in a plastic carrying case our cod. 398 00 01900 ABH4.

Code	Desc.
2310100100	8

Content kit

CODE	DESCRIPTION	PCS
231 00 00100	2	40
231 00 00200	3	20
231 00 00250	3,5	20
231 00 00300	4	10
231 00 00400	5	20
231 00 00500	6	20

## Springs stop hooks

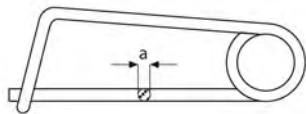

- Galvanized steel flat springs.

Code	Desc. Ø in mm
4350000100	3
4350000200	4
4350000300	5
4350000400	6

## Snap plugs

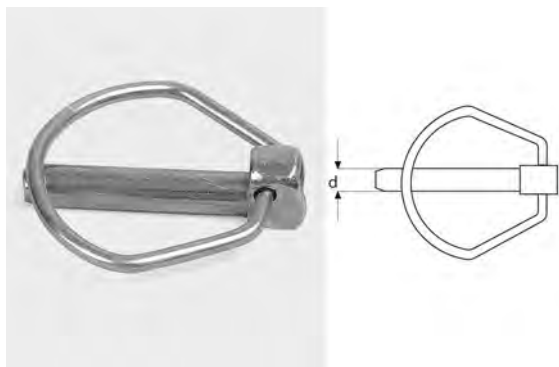

- Galvanized
- Application of agricultural machinery.
- Type of material: galvanized steel.

Code	Desc. d mm
2320000100	5
2320000200	6
2320000350	8
2320000370	9
2320000400	10
2320000500	11

## Safety springs

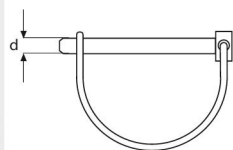

- Plugs Tiller galvanized steel.

Code	Desc. d mm	Length mm
4410000080	8	70
4410000100	10	70

## Pins with head

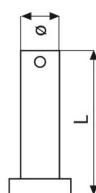

Code	Desc. Ø x L
2880000060	4x15
2880000100	5x10
2880000300	5x15
2880000400	5x18
2880000500	6x15
2880000600	6x18
2880000700	6x20
2880000720	6x25
2880000760	6x32
2880000900	8x18
2880001000	8x20
2880001100	8x22
2880001200	8x25
2880001250	8x30
2880001270	8x37
2880001450	10x27
2880001600	10x30
2880001700	12x30
2880001900	12x35
2880001915	12x43
2880002000	14x40

- Galvanized steel.
- Fork.

## Elastic pins DIN 1481



- Elastic pins in Carbon Steel burnished.
- Rockwell hardness: 43 ÷ 49 Rc.

Code	Desc. Ø nomin. x L
287*****	***

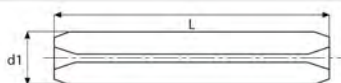

\*\*\*SIZES SEE PRICE LIST

## Assortment spring pins



- Contents: 18 measures of spring pins DIN1481da 2x20 to 10x55.
- Total 346 pieces.
- Supplied in a plastic carrying case our cod. 398 00 01800 201.

Code	Desc.
2870100200	18

Content kit

CODE	DESCRIPTION	PCS
287 00 00200	2X20	50
287 00 00500	3X20	50
287 00 00700	3X30	50
287 00 01000	4X14	25
287 00 01300	4X26	25
287 00 01500	4X36	25
287 00 02000	5X10	12
287 00 02300	5X20	12
287 00 02400	5X30	12
287 00 02700	5X45	12
287 00 03700	6X26	12
287 00 03800	6X30	12
287 00 04200	6X50	12
287 00 04900	8X16	12
287 00 05200	8X30	12
287 00 05400	8X50	5
287 00 06200	10X36	5
287 00 06600	10X55	3

## Turnbuckles at 2 eyes galvanized

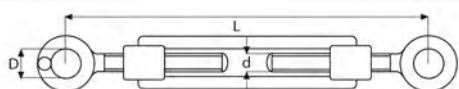

Code	Desc. <i>d</i>	D <i>mm</i>	L min	L max	Workload <i>Kg</i>
5010000100	M6	10	120	180	140
5010000200	M8	11	145	220	240
5010000400	M12	16	195	285	620
5010000500	M16	25	270	415	1100
5010000600	M20	26	290	455	1600
5010000700	M24	35	365	560	2650

## Turnbuckles at eye and hook galvanized

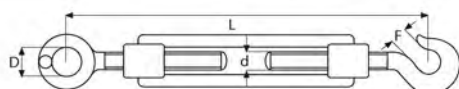

Code	Desc. <i>d</i>	D <i>mm</i>	F <i>mm</i>	L min	L max	Workload <i>Kg</i>
5020000100	M8	11	10	155	235	130
5020000200	M10	14	12,5	185	270	200
5020000300	M12	16	16	210	300	300
5020000400	M16	25	16	285	425	540
5020000500	M20	26	20	310	465	1200



## Galvanized shackles

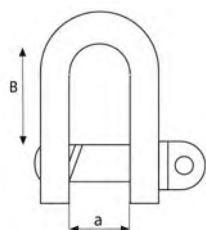

- Dee shackles forged steel galvanized.

Code	Desc.	Workload Kg	a mm	B mm
4370000100	123 - 3/8"	500	20	42
4370000200	124 - 1/2"	630	24	50
4370000300	127 - 9/16"	800	28	57
4370000400	129 - 3/4"	1600	40	70
4370000500	251 - 1"	2500	48	80
4370000600	320 - 1.1/4"	4000	45	100

## Saddle-clamps galvanized wire rope

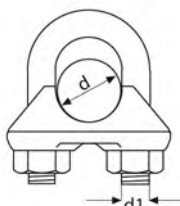

Code	Desc. d	Ø fune	d1 mm
4380000100	3/16"	4 - 5	M 5
4380000200	1/4"	6	M 5
4380000300	5/16"	7 - 8	M 6
4380000400	3/8"	9 - 10	M 8
4380000500	1/2"	12	M 10
4380000600	9/16"	13 - 14	M 10
4380000700	5/8"	15 - 16	M 10
4380000800	3/4"	19 - 20	M 12

## Male eyebolts DIN 580 galvanized

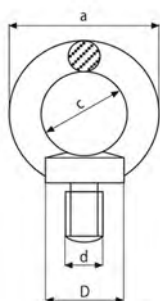

Code	Desc. d	Step MA	a mm	C mm	D mm	Breaking load Kg STRAIGHT	Breaking load Kg 45°
4990000100	M8	1,25	36	20	20	140	90
4990000200	M10	1,5	45	25	25	230	120
4990000300	M12	1,75	54	30	30	340	240
4990000350	M14	2	54	30	30	500	350
4990000400	M16	2	63	35	35	700	500
4990000450	M18	2,5	63	35	40	830	650
4990000500	M20	2,5	72	40	40	1200	830
4990000550	M22	2,5	72	40	40	1500	1050

## Eyebolts female DIN 582 galvanized

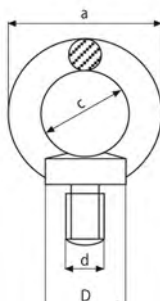

Code	Desc. d	Step MA	a mm	C mm	D mm	Breaking load Kg STRAIGHT	Breaking load Kg 45°
5000000100	M8	1,25	36	20	20	140	95
5000000200	M10	1,5	45	25	25	230	120
5000000300	M12	1,75	54	30	30	340	240
5000000350	M14	2	54	30	30	500	350
5000000400	M16	2	63	35	35	700	500
5000000450	M18	2,5	63	35	40	830	650
5000000500	M20	2,5	72	40	40	1200	830

## Carabiners galvanized

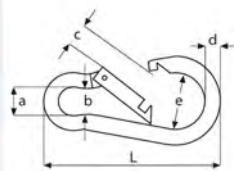

Code	Desc. <i>d</i>	L <i>mm</i>	a <i>mm</i>	B <i>mm</i>	C <i>mm</i>	e <i>mm</i>
5040000100	5	50	8	4	7	16
5040000200	6	60	8,5	5	8	18
5040000300	8	80	12	8	9	22,5
5040000400	10	100	15	10	12	30

## Connecting links quickly galvanized

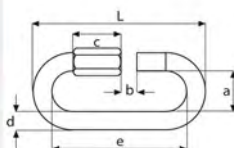

Code	Desc. <i>d</i>	L <i>mm</i>	a <i>mm</i>	B <i>mm</i>	C <i>mm</i>	e <i>mm</i>
5030000100	6	57	14,5	7,5	19	45
5030000150	7	66	16	8,5	21,5	52
5030000200	8	74	17,5	10	23,5	58
5030000300	10	89	20,5	12	29	69

## Dee shackles in stainless steel A4

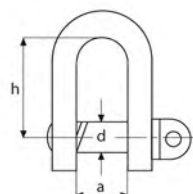

Code	Desc. <i>d</i>	a <i>mm</i>	h <i>mm</i>	Workload <i>Kg</i>
437A400100	8	16	32	3500
437A400200	10	20	40	5400
437A400300	12	24	48	7200

## Saddle-clamps steel A4 for ropes

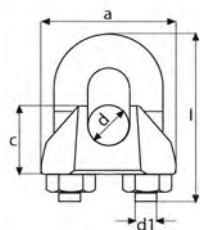

Code	Desc. <i>d</i>	a <i>mm</i>	C <i>mm</i>	d1 <i>mm</i>	I <i>mm</i>	Workload <i>Kg</i>
438A400100	5	12	15	M5	25	1250
438A400200	6	13,8	17	M6	32	2200
438A400300	8	16	20	M6	35	3800
438A400400	10	20	23	M8	44	6750
438A400500	12	25	25,5	M10	55	8000

**INDICATIVE MEASUREMENTS OF ROPE RIVETS STANDARD SERIES**

<b>Ø RIVETS MM</b>	2,4	2,9	3,2	3,4	3,9	4,9	5,9	6,4	7,8
<b>RIVET HEAD MM</b>	5	6	6,5	7	8	10	12	12	14

**Blind rivets in aluminum**



- Rivets in aluminum alloy with galvanized steel nail.
- Dimensions d x L: see description of the price list.

Code	Description dxL
38500*****	See price list

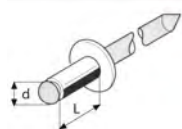

\*\*\*\*\* sizes: see price list

**Aluminum rivets with large head**



- Blind rivets in aluminum alloy head with large 16 mm galvanized steel nail.

Code	Desc. dxL-T	Tigh. thickness. mm
385TL00050	4,8x12-T16	6÷8
385TL00100	4,8x16-T16	10÷12
385TL00200	4,8x20-T16	14÷16
385TL00250	4,8x26-T16	20÷22
385TL00600	5,8x14-T16	8÷10

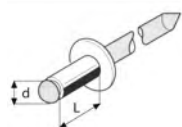

**Blind rivets aluminum colored RAL**

2



- Aluminum rivets painted with nail galvanized steel.
- Available in RAL colors most used in fixtures.

Code	Desc. dxL	Color	Spess. serr. mm
3850B03000	2,9x8/B mm	White RAL 9010	3÷5
3850B03100	2,9x10/B mm	White RAL 9010	5÷7
3850B03200	2,9x12/B mm	White RAL 9010	7÷9
3850B03300	3,9x10/B mm	White RAL 9010	5÷6,5
3850B03400	3,9x12/B mm	White RAL 9010	7÷8,5
3850B03500	3,9x16/B mm	White RAL 9010	10÷12,5
3850B03600	4,8x10/B mm	White RAL 9010	4,5÷6
3850B03700	4,8x12/B mm	White RAL 9010	6,5÷8
3850B03800	4,8x16/B mm	White RAL 9010	9,5÷12
3850B04000	2,9x8/N mm	Black RAL 9005	3÷5
3850B04100	2,9x10/N mm	Black RAL 9005	5÷7
3850B04200	2,9x12/N mm	Black RAL 9005	7÷9
3850B04300	3,9x10/N mm	Black RAL 9005	5÷6,5
3850B04400	3,9x12/N mm	Black RAL 9005	7÷8,5
3850B04500	3,9x16/N mm	Black RAL 9005	10÷12,5
3850B04600	4,8x10/N mm	Black RAL 9005	4,5÷6
3850B04700	4,8x12/N mm	Black RAL 9005	6,5÷8
3850B04800	4,8x16/N mm	Black RAL 9005	9,5÷12
3850B05000	2,9x8/T mm	Brown RAL 8017	3÷5
3850B05300	3,9x10/T mm	Brown RAL 8017	5÷6,5
3850B05400	3,9x12/T mm	Brown RAL 8017	7÷8,5
3850B05500	3,9x16/T mm	Brown RAL 8017	10÷12,5
3850B05600	4,8x10/T mm	Brown RAL 8017	4,5÷6
3850B05700	4,8x12/T mm	Brown RAL 8017	6,5÷8
3850B05800	4,8x16/T mm	Brown RAL 8017	9,5÷12
3850B06000	2,9x8/V mm	Green RAL 6005	3÷5
3850B06100	2,9x10/V mm	Green RAL 6005	5÷7
3850B06200	2,9x12/V mm	Green RAL 6005	7÷9
3850B06300	3,9x10/V mm	Green RAL 6005	5÷6,5
3850B06400	3,9x12/V mm	Green RAL 6005	7÷8,5
3850B06500	3,9x16/V mm	Green RAL 6005	10÷12,5
3850B06600	4,8x10/V mm	Green RAL 6005	4,5÷6
3850B06700	4,8x12/V mm	Green RAL 6005	6,5÷8
3850B06800	4,8x16/V mm	Green RAL 6005	9,5÷12



## Blind rivets anodized blacks

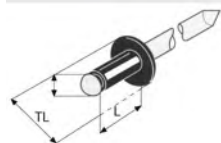

Code	Desc. dxL-T	Tigh. thickness. mm
3900N00050	3,2x11 - T6,5	6÷8
3900N00150	3,2x16 - T6,5	11÷13
3900N00240	3,8x11 -	6,5÷7,5
3900N00242	3,8x14 - TL12	8,5÷10,5
3900N00245	3,8x16 -	10,5÷12,5
3900N00300	4,8x9 -	4÷5
3900N00305	4,8x12 - TL16	7÷8
3900N00310	4,8x14 -	8÷10
3900N00400	4,8x16 - TL16	10÷12
3900N00500	4,8x25 - TL16	20÷22

- Rivets, anodized aluminum alloy ALMg3,5 blacks with galvanized steel nail.
- Required in the automotive industry, such a rivet is indicated in particular for the fixing of the grille, the upholstery and dashboard of cars.

## Galvanized steel rivets

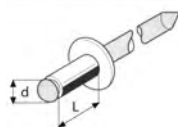

- Blind rivets made of galvanized steel with steel nail

Code	Desc. D x L	Tigh. thickness. mm
4010003600	4,8x16	9,5÷12
4010003700	4,8x18	11,5÷14
4010004300	5,8x18	9,5÷13
4010004400	5,8x22	12,5÷17

## Blind rivets stainless steel

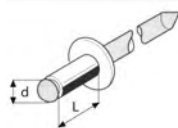

Code	Desc. D x L	Tigh. thickness. mm
3870000100	3,2x5	0,5÷3
3870000300	3,2x9	4÷6
3870000500	3,9x7	2÷3,5
3870000600	3,9x9	3÷5,5
3870000700	3,9x11	5÷7,5
3870000800	3,9x12	7÷8,5
3870000850	3,9x14	8÷10,5
3870000900	3,9x16	10÷12,5
3870000902	3,9x18	12÷14,5
3870000980	4,8x7	0,5÷3
3870001000	4,8x9	2,5÷5
3870001100	4,8x12	5,5÷8
3870001200	4,8x15	9,5÷12
3870001300	4,8x18	11,5÷14
3870001400	4,8x20	13,5÷16

- Rivets alloy steel Cu 80% Ni 20% with stainless steel nail.

## Copper blind rivets

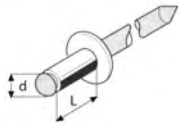

- Copper rivets with natural nail galvanized steel.
- DIN 7337.

Code	Desc. D x L	Tigh. thickness. mm
3900000040	2,9x9	4÷6
3900000058	2,9x16	11÷13
3900000090	3,2x7	2÷4
3900000095	3,2x11	6÷8
3900000100	3,4x5	0,5÷2
3900000200	3,4x7	2÷4
3900000300	3,4x9	4÷6
3900000400	3,4x11	6÷8
3900000502	3,4x14	8÷11
3900000504	3,4x16	11÷13
3900000506	3,4x18	13÷15
3900000518	3,9x9	3,5÷5,5
3900000520	3,9x11	5,5÷7,5
3900000526	3,9x16	10,5÷12,5
3900000528	3,9x18	12,5÷14,5
3900000530	3,9x20	14,5÷16,5
3900000538	3,9x30	21,5÷26,5
3900000545	4,8x12	5,5÷8
3900000550	4,8x16	10÷12
3900000900	4,8x30	19,5÷26

## Aluminum rivets graf



- Rivets graf aluminum AlMg 3.5 with galvanized steel nail.
- This rivet is particularly suitable for fastening of any object on soft materials such as plastic, leather, cardboard, wood, hollow bricks etc. The rivet bushing opens in most parts during fastening thus assuring an optimal combination also on uneven surfaces.

Code	Desc. D x L	Tigh. thickness. mm
3890000100	3,9x12	3÷6
3890000200	3,9x16	6÷10
3890000300	3,9x20	10÷14
3890000400	3,9x24	14÷18
3890000600	3,9x30	18÷24
3890000700	4,8x16	5÷10
3890000900	4,8x24	14÷18
3890001100	4,8x30	18÷22
3890001200	4,8x35	22÷27
3890001300	4,8x40	27÷32
3890001400	4,8x45	32÷37
3890001500	4,8x50	37÷42

## Graf aluminum rivets wide headed anodized blacks



- Rivets in aluminum alloy AlMg 3.5 large head anodized blacks with galvanized steel nail.
- This rivet graf wide head allows a more uniform distribution of pressure in such a way as to make the rivet particularly suitable in the automotive industry for the attachment of any object on soft materials such as plastic, wood, etc.

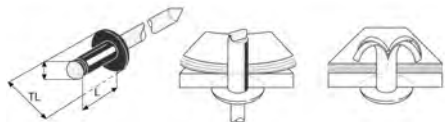

Code	Desc. D x L	Tigh. thickness. mm
389TL00300	4x20-T14	10÷14
389TL00800	4,8x20-T16	10÷16
389TL00900	4,8x25-T16	14÷18

## Assortment aluminum rivets



- Contents: 16 bars of aluminum rivets by 2,9x5 to 6,4x25.
- Total 486 pieces.
- Supplied in a plastic carrying case n / s cod. 398 00 01900 ABH4.

Code	Desc.
3850100100	16

### Content kit

CODE	DESCRIPTION	PCS
385 00 00100	2.9X5	50
385 00 00400	2.9X11	50
385 00 01000	3.2X18	25
385 00 01200	3.4X7	25
385 00 01500	3.4X14	25
385 00 02200	3.9X20	25
385 00 02400	4.9X10	25
385 00 03000	4.9X22	25
385 00 03600	5.9X32	12,5
385 00 03800	6.4X16	12,5
385 00 04000	6.4X25	12,5
385 00 00700	3.2X9	50
385 00 00900	3.2X14	50
385 00 03400	5.9X18	25
385 00 00200	2.9X7	50
385 00 01900	3.9X14	25

## Blind rivets Trimecc



- Blind rivets in aluminum with round head and nail aluminum.
- Suitable for irregular holes and soft materials and pliable as plastic, plywood etc. the expansion creates a good anchorage therefore it is not necessary to interpose a washer.

Code	Desc. D x L	Tigh. thickness. mm
5060000100	4x14	1÷4
5060000200	4x19	1÷7
5060000300	4,8x15	1÷4
5060000400	4,8x20	1÷9
5060000410	4,8x25	3÷11

2

## Trimecc rivets



Code	Description dxL	Tigh. thickness. mm
506TA00100	4X16-Blue Ral 5017	1-4
506TA00300	4X16-Grey Ral 7035	1-4
506TA00500	4X16-Black Ral 9005	1-4
506TA00700	4X19-Blue Ral 5017	1-7
506TA00900	4X19-Grey Ral 7035	1-7
506TA01100	4X19-BlackRal 9005	1-7
506TA01600	4,8X16-Grey Ral 7035	1-4
506TA01700	4,8x20-Blue Ral 5017	1-9
506TA01800	4,8X20-Grey Ral 7035	1-9
506TA01900	4,8X20-Black Ral 9005	1-9
507TA02300	4,8x20 WhiteRal 9010	1-9

- Aluminum rivets to 3 fins, round head with nail aluminum, specific for fastening piaste and in the bodywork (black color).

## Aluminum rivets countersunk head

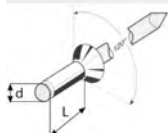

Code	Desc. D x L	Tigh. thickness. mm
3880000100	3,2x7	2÷4
3880000110	3,2x9	4÷6
3880000120	3,2x11	6÷8
3880000130	3,2x13	8÷11
3880000150	3,9x9	3,5÷6
3880000170	3,9x12	7,5÷9
3880000190	3,9x16	10,5÷13
3880000200	3,9x18	12,5÷15
3880000210	3,9x20	14,5÷17
3880000230	4,8x9	3,5÷5
3880000250	4,8x12	6,5÷8
3880000260	4,8x14	7,5÷10
3880000270	4,8x16	9,5÷12
3880000280	4,8x18	11,5÷14
3880000290	4,8x20	13,5÷16

- Blind rivets in aluminum alloy AIMg 3.5 countersunk head with galvanized steel nail.

## Graf rivets

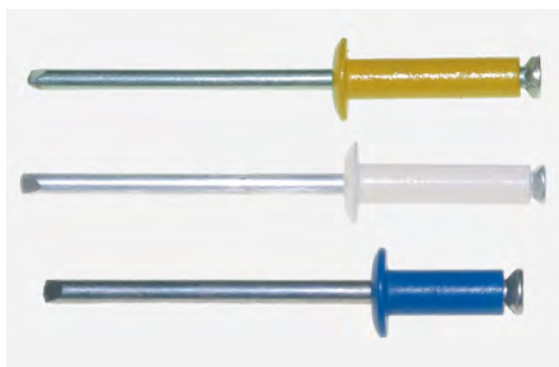

- Rivets graf painted aluminum

Code	Desc. dxL	Color
3890002200	4,8x20	Yellow
3890001910	4x16-T10	Yellow
3890002300	4,8x20	White
3890001922	4x16-T10	White
3890001930	4x16-T12	Blue



## Plastic Blind rivets

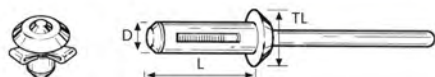

- Blind rivets with nylon body and black nail black acetate.
- Highest accuracy and quality construction.
- They are used to fix plastic on plastic, plastic on metal and plastic on the glass fiber.
- It does not damage painted surfaces or other brittle materials.
- Non-conductive, does not transmit electrical charges
- It does not rust

Code	Desc dxLxTL	Tigh. thickness. mm
506PL00100	5x20-TL12	3,0-6,0
506PL00200	5x25-TL12	6,0-10,0
506PL00300	6,3x18-TL17	4,0-6,0
506PL00400	6,3x28-TL17	4,0-10,0

## Riveting tool for blind rivets in plastic



- Riveting tool fitting for plastic rivets.
- Very compact, long nose is what professionals need to work in parts difficult to reach, especially in the bodywork, bumpers, wheel arches, on license plates.
- This riveting Meccanocar fixed the rivet with a single movement and having a universal nozzle can be used with all sizes of rivets.
- By working in a straight line with the rivet (no angle of 90 °) it is possible to impart a greater force on the material to be fastened.

Code	Desc.
506PL01000	10R

## Kit Riveter with rivets plastic



- Contents: 4 rivets measures:
- 25 pieces 6.3 x 28 x 17
- 25 pieces 6.3 x 18 x 17
- 25 pieces of 5 x 25 x 12
- 25 pieces of 5 x 20 x 12
- Riveting manual art. 506PL01000 - 10R.
- Total 101 pieces.
- Practical plastic case.

Code	Desc.
506PL02000	KIT

## Il sistema Monobolt

IL SISTEMA MONOBOLT E' PARTICOLARMENTE ADATTO PER APPLICAZIONI SU COMPONENTI SOGGETTI A VIBRAZIONI, PUO' SOSTITUIRE LE TECNOLOGIE TRADIZIONALI COME DADO-BULLONE, RIBATTINI SOLIDI E SALDATURA. QUESTO RIVETTO SI APPLICA CON UN ATTREZZO OLEOPNEUMATICO RIUSCENDO AD ASSEMBLARE COMPONENTI CON SPESSORI DIVERSI. IL RIVETTO MONOBOLT E' DISPONIBILE CON Ø 4,8 E 6,4 mm IN MATERIALI DIVERSI: ACCIAIO - ALLUMINIO - INOX E NELLE VERSIONI A TESTA TONDA E SVASATA

### Come funziona

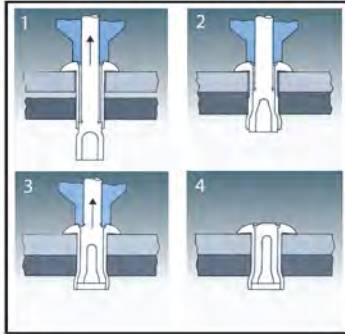

- 1) IL BULLONE MONOBOLT GIA' INSERITO NEL NASELLO DELL'ATTREZZO VIENE INTRODOTTO NEL FORO DEI COMPONENTI DA ASSEMBLARE
- 2) AZIONANDO L'ATTREZZO IL GAMBO SUBISCE UNA TRAZIONE, LA TESTA DELLO STESSO TRAFILA IL CORPO: OTTENIAMO COSI' L'AVVICINAMENTO DEI COMPONENTI
- 3) CONTINUANDO L'AZIONE DI TRASCINAMENTO DEL GAMBO OTTENIAMO IL COMPLETO RIEMPIMENTO DEL FORO
- 4) QUANDO LA SEZIONE MAGGIORE DEL GAMBO CONTRASTA IL NASELLO DELL'ATTREZZO, IL GAMBO STESSO SI ROMPE NEL PUNTO PRESTABILITO (A FILO DI TESTA)



### Bloccaggio del gambo

UNA DELLE CARATTERISTICHE PRINCIPALI DEL MONOBOLT CONSISTE NEL BLOCCAGGIO MECCANICO DEL GAMBO, CONDIZIONE INDISPENSABILE PER GARANTIRE UNA GIUNZIONE DI TIPO STRUTTURALE

## Monobolt rivets round head (TT) and countersunk head (TS) aluminum

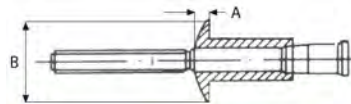

TIPO DI MATERIALE	
CORPO	5056 - 0 DIN AL Mg 5% No. 3.3555
GAMBO	2014 - T6 DIN AL CU S. Mn 3.1255

Ø BULLONE	DATI TECNICI		
	CARICHI (N)		
	TAGLIO	TRAZIONE	ESPULSIONE GAMBO
4,8	3002	2224	222
6,4	6005	4226	445

Code	Desc.	Tigh. thickness. mm	Ø recom. hole	A	B
410AL00100	4,8x14 TT	1,6 - 11,1	4,9 - 5,1	1,7 - 2,1	9,5 - 10
410AL00150	6,4x15 TT	2,0 - 9,5	6,6 - 7,0	2,4 - 2,9	12,8 - 13,3
410AL00200	6,4x20 TT	2,0 - 15,9	6,6 - 7,0	2,4 - 2,9	12,8 - 13,3
410AL00350	6,4x17 TS	2,0 - 9,5	6,6 - 7,0	2,4 - 2,9	12,8 - 13,3

## Monobolt rivets round head (TT) Steel A2

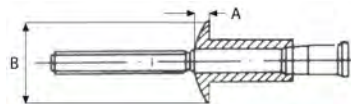

TIPO DI MATERIALE	
CORPO	AISI 304 (+ 3-4% Cu)
GAMBO	AISI 304 (+ 3-4% Cu)

Ø BULLONE	DATI TECNICI		
	CARICHI (N)		
	TAGLIO	TRAZIONE	ESPULSIONE GAMBO
4,8	6449	5115	444
6,4	11787	10453	1112

Code	Desc.	Tigh. thickness. mm	Ø recom. hole	A	B
410A200800	4,8x13 TT	1,6 - 6,9	4,9 - 5,1	1,7 - 2,1	9,5 - 10
410A200850	4,8x14 TT	1,6 - 11,1	4,9 - 5,1	1,7 - 2,1	9,5 - 10
410A200900	6,4x15 TT	2,0 - 9,5	6,6 - 7,0	2,4 - 2,9	12,8 - 13,3
410A200950	6,4x20 TT	2,0 - 15,9	6,6 - 7,0	2,4 - 2,9	12,8 - 13,3

## Riveting machines for blind rivets



- New manual riveting machine for rivet D.2.4-4.8 (aluminum only).
- With the system of detention nail.
- Weight 0.530 kg.
- Small footprint.

Code	Description	Range
3950000110	1/B	2.4 - 4.8
3850004160	A10 Replacement kits clamps	-

## Riveting tool manual long



- For rivet D.2,4-4,8 all leagues
- Spring Return
- With long levers for the relief effort in the draw of the rivets

Code	Description	Range
3950000110	1/B	2,4 - 4,8
3850004160	A10 Replacement kits clamps	-

## Riveting tool at rotating head

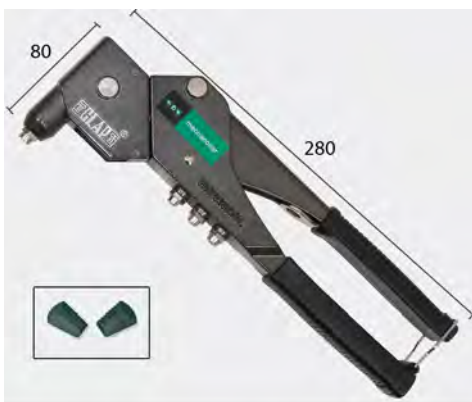

- For rivet 2.4 to 4.8 only aluminum and copper.
- Swivel head 360°.
- Suitable for working in confined spaces and not accessible by normal riveting.
- The riveting head swivel his catatteristiche is pretty tough draw in the rivet.
- Not suitable for intensive use and continuous.



Code	Description	Range
3950000301	3/1	2,4-4,8
3950000302	KIT TERMINALS	Clamp kit parts (2 pcs)

## Riveting long levers

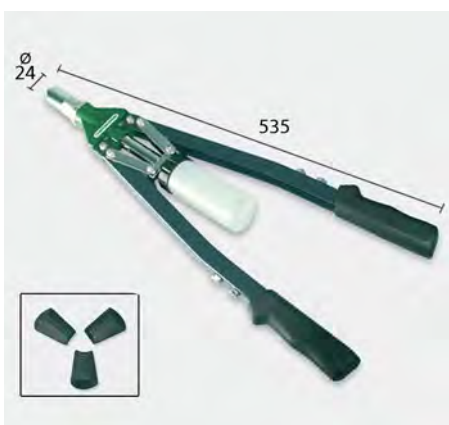

- For rivet D.3.2-6.4 all leagues + D.7.8 only aluminum rivets.
- Weight 1.80 kg.
- With tank for the recovery of the nail veneer.
- To use continuous and hard.

Code	Description	Range
3950000200	2	3,2-6.4+7.8 all
3850004110	A4-S Replacement kits clamps	-

2

## Pneumatic riveting tool



- For rivet D.2.4-5 (only aluminum).
- Particularly handy.

Code	Description	Range
3950000310	4	2.4-5 (aluminum only)
3850004110	A4-S Replacement kits clamps	-

## Riveter oleopneumatic



- For rivet 2.4 to 4.8 all leagues
- Riveting tool balanced for continuous thanks to the lack of effort on the button for the operator
- With swivel connector mounted
- Air connection 1/4 "female gas

Code	Description	Range
3950000800	9	2.4 - 4.8 all leagues
3950000810	KIT TERMINALS 395/9	Clamp kit parts (2 pcs)

## Riveting machine oleopneumatic



- For rivet 2.4 to 6.4 all leagues
- Used to pull the rivets Structural type Monobolt and Magna-lok
- Riveting tool balanced for continuous thanks to the lack of effort on the button for the operator
- For the use of structural rivets it is sufficient replacing the nozzle already supplied.
- With air connection 1/4 "female gas

Code	Description	Range
3950000900	10	2,4-6,4 All alloys
3950000910	CLAMPS KIT FOR 395/10	Spare clamp kit





Assortment aluminum rivets

- Contents: 16 bars of aluminum rivets by 2,9x5 to 6,4x25.
- Total 486 pieces.
- Supplied in a plastic carrying case n / s cod. 398 00 01900 ABH4.

Code	Desc.
3850100100	16

Content kit

CODE	DESCRIPTION	PCS
385 00 00100	2.9X5	50
385 00 00400	2.9X11	50
385 00 01000	3.2X18	25
385 00 01200	3.4X7	25
385 00 01500	3.4X14	25
385 00 02200	3.9X20	25
385 00 02400	4.9X10	25
385 00 03000	4.9X22	25
385 00 03600	5.9X32	12,5
385 00 03800	6.4X16	12,5
385 00 04000	6.4X25	12,5
385 00 00700	3.2X9	50
385 00 00900	3.2X14	50
385 00 03400	5.9X18	25
385 00 00200	2.9X7	50
385 00 01900	3.9X14	25

Threaded rivets rubber

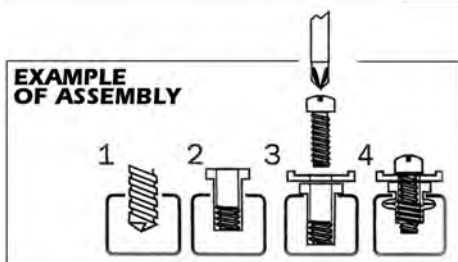
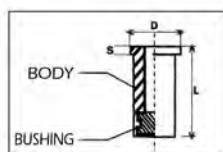

- Threaded tubular rivets rubber (Wellnut type).
- Antivibration.
- Particularly suitable for fixings subject to vibrations.
- Used on boxes or tubes.
- The neoprene body ensures chemical resistance, electrical insulation and soundproofing.
- The brass bush ensures a good seal and good resistance to corrosion.
- Particularly suitable in the motorcycle sector for the attachment of the hulls and plastic details.

Code	Desc.	Spessore serr. ØxL	D head mm	Tthread	D. est. mm	Spess. testa mm	D. perforation mm
2930004006	4006-4x12,5	0,5-4,0	11	M4	7,9	1,4	8-8,3
2930004007	4007-5x14	0,5-5,0	12,7	M5	9,6	0,9	9,7-9,9
2930004008	4008-5x21,5	8,0-11,0	14	M5	9,6	0,9	9,7-9,9
2930004009	4009-5x26	8,0-16,0	14	M5	9,6	1,3	9,7-9,9
2930004010	4010-6x21	0,5-5,0	19	M6	12,7	4,7	12-13
2930004011	4011-6x26,5	6,0-11,0	26,5	M6	12,7	2,0	12,8-13

## Threaded steel inserts



- Galvanized steel cylindrical threaded inserts, anti-twist screw, smooth or knurled body.
- Useful for making threads on sheet and small details

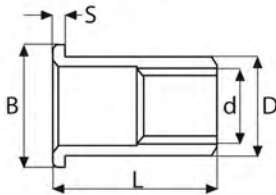

Code	Desc.	d mm	Spess. serr.	Ø foro	D mm	B mm	S mm	L mm	Model
4240001000	4 Z	M4	0,3/2,5	6	5,9	9	1,0	11,0	INSERTS KNURLED
4240001100	5 Z	M5	0,3/3,0	7	6,9	10	1,2	13,0	INSERTS KNURLED
4240001200	6 Z	M6	0,5/3,0	9	8,9	12	1,5	14,5	INSERTS KNURLED
4240001300	8 Z	M8	0,5/3,0	11	10,9	15	1,5	17,5	INSERTS KNURLED
4240000100	3	M3	0,3/1,8	5	4,9	7	0,8	9,0	INSERTS SMOOTH
4240000200	4	M4	0,3/2,5	6	5,9	9	1,0	11,0	INSERTS SMOOTH
4240000300	5	M5	0,5/3,0	7	6,9	10	1,2	13,0	INSERTS SMOOTH
4240000400	6	M6	0,5/2,3	9	8,9	12	1,5	14,5	INSERTS SMOOTH
4240000500	8	M8	0,8/3,5	11	10,9	15	1,5	17,5	INSERTS SMOOTH
4240000600	10	M10	1,0/3,5	12	11,9	16	1,7	19,0	INSERTS SMOOTH

## Threaded inserts in aluminum

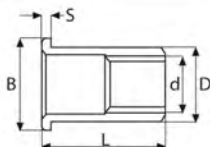

Code	Desc.	d mm	Spess. serr.	Ø foro	D mm	B mm	S mm	L mm
4250000100	3	M3	0,3/1,8	5	4,9	7	0,8	9
4250000200	4	M4	0,3/2,5	6	5,9	9	1	11
4250000300	5	M5	0,5/3	7	6,9	10	1,2	13
4250000400	6	M6	0,5/2,3	9	8,9	12	1,5	14,5
4250000500	8	M8	0,8/3,5	11	10,9	15	1,5	17,5
4250000600	10	M10	1/3,5	12	11,9	16	1,7	19

- Underhead knurled
- Threaded inserts in aluminum alloy cylinder head

## Manual pulls inserts



- For female threaded inserts from M3 to M6.
- For aluminum, steel and stainless steel inserts.
- Supplied in a clear plastic bag.

Code	Desc.	Range
4250100700	901	M3 to M6

## Replacement tie rods to clamp M3 to M6



Code	Description	For female inserts
4250100703	901-M3 tie-beam	M3
4250100704	901-M4 tie-beam	M4
4250100705	901-M5 tie-beam	M5
4250100706	901-M6 tie-beam	M6
4250100713	901-M3 head	M3
4250100714	901-M4 head	M4
4250100715	901-M5 head	M5
4250100716	901-M6 head	M6

- Tie rods and replacement brush heads from M3 to M6

## Pulls inserts manual



- For female threaded inserts from M3 to M10
- For aluminum, steel and stainless steel inserts.
- With long levers to decrease operator fatigue.

Code	Desc.	Range
4250100800	903	M3 to M10

2

## Replacement tie rods for M3 to M10 clip



Code	Description	For female inserts
4250100803	903-M3 tie rod	M3
4250100804	903-M4 tie rod	M4
4250100805	903-M5 tie rod	M5
4250100806	903-M6 tie rod	M6
4250100808	903-M8 tie rod	M8
4250100810	903-M10 tie rod	M10
4250100823	903-M3 head	M3
4250100824	903-M4 head	M4
250100825	903-M5 head	M5
4250100826	903-M6 head	M6
4250100828	903-M8 head	M8
4250100830	903-M10 head	M10

- Tie rods and replacement brush heads from M3 to M10
- For female inserts

## Oleopneumatic pulls inserts



- For female threaded inserts from M3 to M12
- Air connection 1/4" female gas
- Threaded inserts for aluminum and steel including stainless steel
- Supplied in case

Code	Description	For female inserts
4250100600	RIVETING M3-M12	FROM M3 TO M12

## Spare parts for hydraulic vacuum riveter

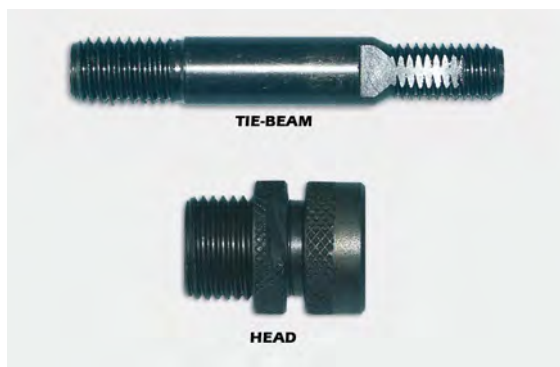

Code	Description	For female inserts
4250100603	TM3-TIE ROD	M3
4250100604	TM4-TIE ROD	M4
4250100605	TM5-TIE ROD	M5
4250100606	TM6-TIE ROD	M6
4250100608	TM8-TIE ROD	M8
4250100610	TM10-TIE ROD	M10
4250100612	TM12-TIE ROD	M12
4250100623	TG-M3-HEAD WITH BUSH	M3
4250100624	TG-M4-HEAD WITH BUSH	M4
4250100625	TG-M5-HEAD WITH BUSH	M5
4250100626	TG-M6-HEAD WITH BUSH	M6
4250100628	TG-M8-HEAD WITH BUSH	M8
4250100630	TG-M10-HEAD WITH BUSH	M10
4250100632	TG-M12-HEAD WITH BUSH	M12



## Nylon cable ties for wiring



- Hand tools for pulling pliers see our art. cod. 2940005750-2109 and cod.2940005730 - 2104.

Code	Desc.	Dimension <i>Width X length mm.</i>	Color
2940056190	0041B	2,2x75	WHITE
2940056200	0042B	2,5x98	WHITE
2940056300	0043B	2,6x160	WHITE
2940056400	0044B	2,6x200	WHITE
2940067805	00264B	3,6x200	WHITE
2940067905	00265B	3,6x290	WHITE
2940068300	00269B	4,8x195	WHITE
2940075200	00357B	4,8x292	WHITE
2940056810	0048B	4,8x360	WHITE
2940085035	00602B	7,8x750	WHITE
2940056210	0042N	2,5x98	BLACK
2940056310	0043N	2,6x160	BLACK
2940056410	0044N	2,6x200	BLACK
2940067800	00264N	3,6x200	BLACK
2940067900	00265N	3,6x290	BLACK
2940068310	00269N	4,8x195	BLACK
2940075210	00357N	4,8x292	BLACK
2940056800	0048N	4,8x360	BLACK
2940072920	00324	7,6x240	BLACK
2940072930	00325	7,6x365	BLACK
2940085040	00602N	7,6x750	BLACK
2940085013	00601N	9x780	BLACK
2940072950	00326	7,6x540	BLACK
2940068302	00269V	4,8x200	GREEN
2940068304	00269G	4,8x200	JELLOW
2940068306	00269BL	4,8x200	BLUE
2940068308	00269R	4,8x200	RED

## Nylon cable ties with metal tooth



Code	Desc.	Dimension <i>Width X length mm.</i>	Color
2940084960	00584	2,4x92	WHITE
2940084970	00586	2,4x200	WHITE
2940084980	00588	3,6x208	WHITE
2940084990	00590	3,6x281	WHITE
2940085000	00592B	4,8x360	WHITE
2940084965	00585	2,4x92	BLACK
2940084975	00587	2,4x200	BLACK
2940084985	00589	3,6x208	BLACK
2940084995	00591	3,6x281	BLACK
2940085002	00592N	4,8x360	BLACK

- Nylon ties 6.6.
- Retention tooth in AISI 316 steel.
- This type of clamp guarantees a top ring of the wiring.
- Hand tools for pulling pliers see our art. cod. 2940005750-2109 and cod. 2940005730-2104.

## Portafascette per fascette in nylon



- Portafascette metallico a 5 scomparti.
- Dotato di 4 divisori mobili per potersi adattare alle esigenze dell'operatore.
- Possibile utilizzo sia da appoggio che a parete.
- Colore verde ral 6029.
- Capacita' di inserimento fascette da lunghezza 75mm a 360mm.

Code	Desc.	Dimens. (mm)
4700008070	812	L330xH320xP52



## Portafascette con fascette nere in nylon



Code	Description	Qty.
2940090001	01	kit completo

Spare Parts		
Code	Description	Quantity
2940056210	0042N-fascette 2.5x99 nera	200
2940056310	0043N-fascette 2.6x160 nera	200
2940067800	00264N-fascette 3.6x200 nera	200
2940075210	00357N-fascette 4.8x292 nera	200
2940056800	0048-fascette 4.8x360 nera	200
4700008070	812-portafascette	1

## Portafascette con fascette bianche in nylon



Code	Description	Qty.
2940090005	05	kit completo

Spare Parts		
Code	Description	Quantity
2940056200	0042B-fascette 2.5x99 bianca	200
2940056300	0043B-fascette 2.6x160 bianca	200
2940067805	00264B-fascette 3.6x200 bianca	200
2940075200	00357B-fascette 4.8x292 bianca	200
2940056810	0048B-fascette 4.8x360 bianca	200
4700008070	812-portafascette	1

## Plastic ties



Code	Desc.	Dimension <i>Width X length mm.</i>	Color
2940002651	594/RA	mm 9x180	BLACK



- Polyamide 12, black
- Compliant and f hn 33s62 (French electricity authority - equivalent Enel)
- Excellent resistance to UV rays and chemical agents
- With head coupling single

## Clamps with double hook head



Code	Desc.	Dimension <i>Width X length mm.</i>	Color
2940002657	596/RA	mm 9x265	BLACK
2940002653	595/RA	mm 9x360	BLACK



## Reusable plastic ties



- Polyamide.
- The movable retaining tooth allows the reuse of the strap without compromising the seal.

Code	Desc.	Dimension <i>Width X length mm.</i>	Color
2940056600	0046	7,5x250	WHITE



2

## Reusable strap mobile head



Code	Desc.	Dimension <i>Width X length mm.</i>	Color
2940056900	0049	7,6x370	BLACK



- Polyamide.
- The mobile head allows the reuse of the strap.
- Particularly suitable for fastening wiring to the frame in the sector of the industrial vehicle.

## Fascetta d'identificazione in poliammide

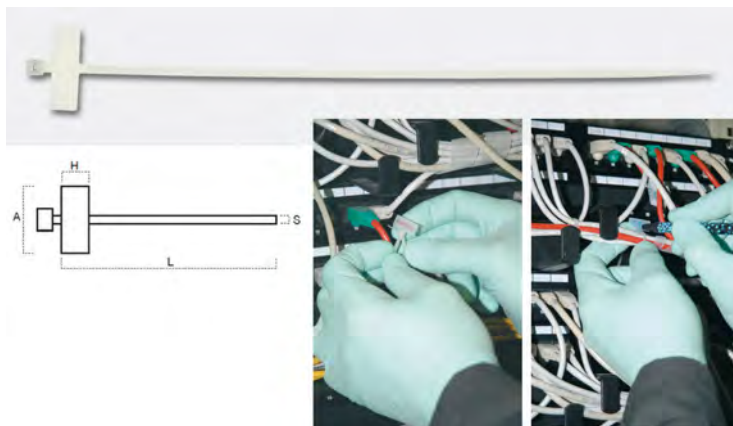

- Fascetta in poliammide 6.6.
- **Campi d'impiego:** settore elettrico, impiantistico.
- **Caratteristiche:** serra fasci di cavi e contemporaneamente li identifica.
- La targhetta puo' essere marchiata con un pennarello indelebile.
- Colore bianco.

Code	Desc.	L	S	A	H
2940085090	100x2,5T	100	2,5	25,4	

## Sideburns anchor bidirectional

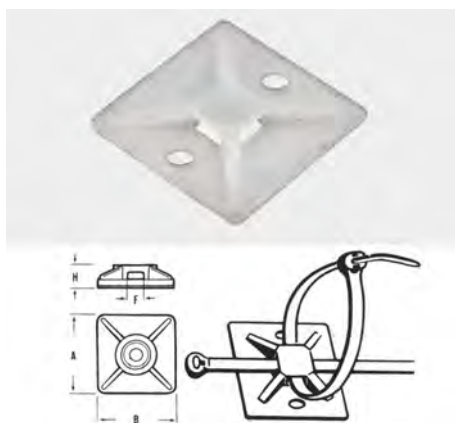

- With adhesive backing
- For plastic ties width. max 3.6 to 4.8 mm
- double hook

Code	Desc.	Dimension <i>AxB</i>	Insertable clamps <i>Width Max mm</i>	Color
2930003081	3081	mm 19x19	mm 3,6	WHITE
2930003082	3082	mm 26,5x26,5	mm 4,8	WHITE
2930003091	3091	mm 26,5x26,5	mm 4,8	BLACK



## Supports saddle clamps



- Special media for fastening cables or cable harnesses with plastic cable ties, type our code 29400.
- Made of polyamide 6.6 with hole for fixing with screws, bolts and rivets.
- It simplifies the hardware of large bundles of cables in confined spaces.
- Available in two sizes, black or natural.

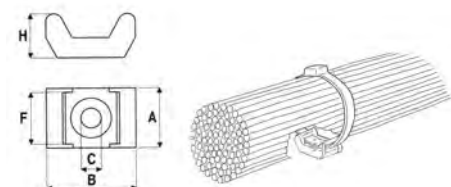

Code	Desc.	Color	Lung. Max fascetta mm	A mm	B mm	C mm	F mm	H mm
155TA06700	26/1	WHITE	5	9,5	15	3,5	5	7
155TA06750	26/2	WHITE	9	14,6	22,5	5	9,3	11
155TA06800	26/3	BLACK	5	9,5	15	3,5	5	7
155TA06850	26/4	BLACK	9	14,6	22,5	5	9,3	11

## Professional metal pliers



- Professional metal pliers for optimum tightening of plastic straps
- The tension is manually adjustable
- The cut of the excess is via lever

Code	Desc.	Con capacità	Photo
2940005750	2109	4,8 ÷ 9	1
2940005730	2104	2,2 ÷ 4,8	2

## Pliers cut plastic ties



- Pliers for cutting in safety of plastic cable ties.
- Thanks to the innovative shape of the jaws, the pliers cut the strap safely avoid damaging cables or the material to which it is anchored in the tie.
- Utensil compact, just 150mm long, also lends itself to work in a confined space such as an engine compartment, an electric switchboard, a junction box.
- Suitable for mechanics, electricians, repairmen generally.
- Cutting safely.
- Not usable for cutting of metal parts.



TAGLIO IN TOTALE SICUREZZA  
NON UTILIZZARE PER PARTI  
METALLICHE

Code	Desc.	Length mm
4430056870	1792-150	150

2

## Ties 2 ears galvanized



- The cheapest way to tighten permanently tubes of small and medium size.
- Strip galvanized steel and passivated for optimum protection.
- They can be applied with a normal pincer type our art. cod. 420 00 93250.

Code	Desc. Range Ø	Width tape mm
3000000400	5.0 - 7.0	6
3000000500	7.0 - 9.0	7
3000000600	8.0 - 11.0	7
3000000700	9.0 - 12.0	7
3000000800	11.0 - 13.0	7
3000000900	13.0 - 15.0	7
3000001000	14.0 - 17.0	7
3000001100	15.0 - 18.0	7
3000001200	17.0 - 20.0	7
3000001400	20.0 - 23.0	7

## Ties "Clic" stainless steel



- Tie with ribbon produced in one piece of stainless steel smooth inside.
- The perfectly circular shape of the clamp and the sliding of the inner tongue in a groove avoids possible pinching of the tube at the time of tightening.
- Bands will click are widely used in the automotive industry and home appliances in various industries.

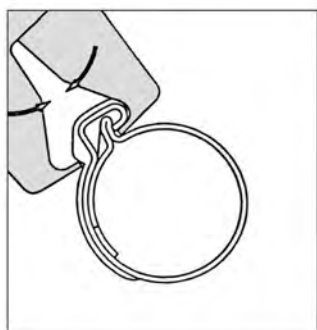
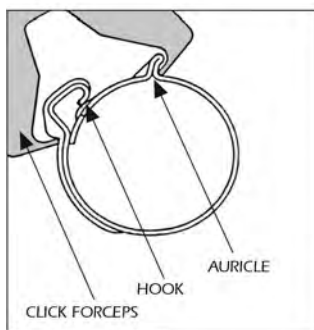

Code	Desc.	Application Ø	Width tape mm	Resist. max BAR
3020000100	085	9-10	5	20
3020000200	090	9,5-11	5	20
3020000230	095	10-11,5	5	20
3020000250	105	11-12,5	6	18
3020000300	120	12,5-14,5	6	18
3020000400	125	13-15	6	18
3020000500	130	13,5-15,5	6	18
3020000600	140	14,5-16,5	8	15
3020000700	150	15,5-17,5	8	15
3020000800	165	17-19	6	15
3020000900	185	19-21	8	12
3020001000	210	21,5-23,5	8	12
3020001100	230	23,5-25,5	8	12

## Assortment ties "Click" with pliers



- Assortment of bands model "Click".
- Suitable for automotive, household appliances and various industries.
- Supplied in a practical plastic case (our code 3980001900) with inside the clamp-specific installation and removal of clamps (our code 3020100300).

Code	Description
3020100400	597-assortment of clamps with clamp

### Content kit

CODE	DESCRIPTION	Diam. mm	PCS
302 00 00300	120	12,5 - 14,5	75
302 00 00400	125	13 - 15	75
302 00 00500	130	13,5 - 15,5	25
302 00 00600	140	14,5 - 16,5	25
302 00 00700	150	15,5 - 17,5	25
302 00 00800	165	17 - 19	25
302 01 00300	596	-	1

## Pliers for clamps "Click"



- Special alloy clamp assembly / disassembly ties

Code	Desc.
3020100300	596

## Small pipe clamps



- Pipe clamps with worm screw.
- Strip stainless steel AISI 430, stainless steel yellow zinc plated, screw type 8.8 Round head slotted 4mm.

Code	Desc. Serr. mm	Tape height mm
311A200100	11x19	5
311A100100	7x11	5

## Gasoline hose clamps

2



Code	Desc.	For pipes mm	Marking clamp	Vite mm	Width band mm
3070000200	8/9	7-9	8	7	9
3070000300	10/9	8-10	9	7	9
3070000400	11/9	9-11	10	7	9
3070000500	12/9	10-12	11	7	9
3070000600	13/9	11-13	12	7	9
3070000700	14/9	12-14	13	7	9
3070000800	15/9	13-15	14	7	9
3070000900	16/9	14-16	15	7	9
3070000950	17/9	15-17	16	7	9
3070001000	18/9	16-18	17	7	9
3070001050	19/9	17-19	18	7	9
3070001100	20/9	18-20	19	7	9

- Rounded edges.
- Galvanized steel.
- Hose and low pressure screw hexagon M7 + screwdriver slot.
- **N.B. on the band is marked, the average size of tightening. Example: 307 00 00 300 9.10 8.10 tightening, the marking is 9.**

## Clamps rubber coated



Code	Desc. Ø	Tape height mm	Ø max serrabile	Ø foro
3060000100	6/15	15	6	6
3060000200	8/15	15	8	6
3060000300	10/15	15	10	6
3060000400	12/15	15	12	6
3060000500	15/15	15	15	6
3060000600	18/15	15	18	6
3060000700	20/15	15	20	6
3060000800	25/15	15	25	6
3060000900	30/15	15	30	6
3060000920	40/15	15	40	6
3060001000	15/20	20	15	8
3060001100	20/20	20	20	8
3060001200	25/20	20	25	8
3060001300	30/20	20	30	8
3060001310	35/20	20	35	8
3060001320	38/20	20	38	8
3060001400	50/20	20	50	8
3060001450	70/25	25	70	8

- The rubber profile (EPDM) highly water-resistant, wear and aging, prevents any vibration this type of clamp is especially used for the fixation of pipes, cables, wiring in the auto industry, in the construction of machinery in plants hydraulic and pneumatic systems, in refrigeration.
- Available in 2 widths 15:20 mm
- According to DIN 3016.



## Screw clamps Norma Type



Code	Desc. Ø lockable mm	Tape height mm
312000050	8x12	9
312000100	10x16	9
312000200	12x20	9
312000300	16x25	9
312000400	20x32	9
312000500	23x35	9
312000600	25x40	9
312000700	32x50	9
312000800	40x60	9
312000900	50x70	9
312001000	60x80	9
312001100	70x90	9
312001150	80x100	9
312001200	90x110	9

ΣΤΑΝΤ ΣΦΙΓΚΤΗΡΕΣ 100 ΤΕΜ. ΑΠΟΤΕΛΕΙΤΑΙ ΑΠΟ ΤΑ ΠΑΡΑΚΑΤΩ ΝΟΥΜΕΡΑ.



CODICE	DESC. Ø
312 00 00050	8x12
312 00 00100	10x16
312 00 00200	12x20
312 00 00300	16x25
312 00 00400	20x32
312 00 00500	23x32
312 00 00600	25x40
312 00 00700	32x50
312 00 00800	40x60

### Content kit

CODICE	DESC. Ø
312 00 00050	8x12
312 00 00100	10x16
312 00 00200	12x20
312 00 00300	16x25
312 00 00400	20x32
312 00 00500	23x32
312 00 00600	25x40
312 00 00700	32x50
312 00 00800	40x60

Code	Description
3122000300	76 COMPLETE EXHIBITOR
3990001600	EXHIBITOR EMPTY



### ΣΦΙΓΚΤΗΡΕΣ ΓΙΑ ΦΟΥΣΚΕΣ ΗΜΙΑΞΟΝΙΩΝ

- Stainless steel AISI 301 - en 10088-2.
- Two measures can cover a range from 20 to 120 mm.
- Quick to install and safe over time.
- Belt width 7mm.
- Thickness 0.5 mm.

Code	Desc.
5090002000	20-45
5090002010	45-120

2

## Box clamps Norma type



- Practical portable cabinet or be wall-mounted.
- 12 containers larks with stop limit switches.
- Hatches in plexiglass dust.
- Contents: 450 cable ties worm, band 9 mm.

Code	Description
3122000200	450-BOX COMPLETE
3980001500	198 EMPTY BOX

### Content kit

DIMENS.	PCS
8x12	50
10x16	100
12x20	100
16x25	100
20x32	50
25x40	40
32x50	10



## Exhibitor clamps "Norma" type



- Exhibitor painted metal.
- With hooks for attaching to the wall and pedestal for mounting on a flat base.
- It Contains n°76 ties norma type.
- Ties with high band 9 mm.
- Dimensions: width 365 mm - height 340 mm - 165 mm depth.
- Use sectors: general workshops, workshops motorcycles and cars, car bodies, car electrician, etc.

Code	Description
3122000300	76 COMPLETE EXHIBITOR
3990001600	EXHIBITOR EMPTY

### Content kit

CODICE	DESC. Ø
312 00 00050	8x12
312 00 00100	10x16
312 00 00200	12x20
312 00 00300	16x25
312 00 00400	20x32
312 00 00500	23x32
312 00 00600	25x40
312 00 00700	32x50
312 00 00800	40x60

## Low pipe clamps



- Pipe clamp with worm screw.
- End stainless steel AISI 430, screw class 8.8 hexagonal 6mm + screwdriver slot, stainless steel, carbon Chromium plated zinc yellow passivated.
- Totally folded collar.
- The collar fold allows the use of the clamp without removing the sleeve or tube from Home!

Code	Desc. Ø lockable mm	Tape height mm
3110B00400	24x36	9
3110B00500	24x44	9
3110B00600	32x52	9
3110B00700	40x60	9
3110B00800	47x67	9
3110B00900	62x82	9
3110B01000	77x97	9

## High pipe clamps



- Pipe clamp with worm screw.
- End stainless steel AISI 430, screw class 8.8 hexagonal 8 mm + screwdriver slot, stainless steel, carbon Chromium plated zinc yellow passivated.
- Collar totally folded.
- The collar fold allows the use of the clamp without removing the sleeve or tube from Home!

Code	Desc. Ø lockable mm	Tape height mm
3110C00100	14x22	12
3110C00200	20x30	12
3110C00300	24x36	12
3110C00400	24x44	12
3110C00500	32x52	12
3110C00600	40x60	12
3110C00700	47x67	12
3110C00800	62x82	12



## Large pipe clamps



- Pipe clamp with worm screw.
- End stainless steel AISI 430, screw class 8.8 hex head + 8 mm screwdriver slot, stainless steel, carbon Chromium plated zinc yellow passivated.
- Collar totally folded.
- The collar fold allows the use of the clamp without removing the sleeve or tube from Home!

Code	Desc. Ø lockable mm	Tape height mm
3110D00100	77x97	12
3110D00200	92x112	12
3110D00300	107x127	12



## Radial band



- Expandable radial band fixed by screws
- Band designed to resolve the problem of dilation and expansion of manifolds due to thermal excursion
- The special expandable sector mounted on the band compensates for the manifolds excursions, thereby guaranteeing a constant seal of the assembly torque utilised.
- Band, carriage and screws are manufactured from AISI 430 steel; the expandable sector from AISI 304 steel
- For fixing we recommend n / s art. flex screwdriver cod. 4200100345-7

Code	Desc. Ø lockable mm	Band width mm
3130000100	8-16	9
3130000200	12-22	9
3130001100	16-27	12
3130001200	23-35	12
3130001300	30-45	12
3130001400	35-50	12
3130001500	40-60	12
3130001600	50-70	12
3130001700	60-80	12
3130001800	70-90	12
3130001900	80-100	12
3130002000	90-110	12
3130002100	110-130	12



## Ties "Aba" in galvanized steel and stainless steel AISI 304 18/8



- Clamp in galvanized steel, painted case, screw hexagonal 7 mm + slotted galvanized steel.
- Stainless steel band, case and screw hexagonal 7 mm + slotted stainless steel.
- Steel for industrial, agricultural, chemical and boating.
- Tape width 9 mm and 12.2 mm.
- To tighten recommend our art. screwdriver flex cod. 4200100345.
- NB: it is engraved on the band measurement max lockable example: 22x32 32.

Code	Desc. <i>measure mm</i>	Tape height <i>mm</i>	Type
4920000100	8-14	9	GALVANIZED STEEL
4920000200	11-17	9	GALVANIZED STEEL
4920000300	13-20	9	GALVANIZED STEEL
4920000400	15-24	9	GALVANIZED STEEL
4920000500	19-28	9	GALVANIZED STEEL
4920000600	22-32	9	GALVANIZED STEEL
4920000700	26-38	9	GALVANIZED STEEL
4920000800	32-44	9	GALVANIZED STEEL
4920000900	38-50	9	GALVANIZED STEEL
4920001000	15-24	12,2	GALVANIZED STEEL
4920001100	19-28	12,2	GALVANIZED STEEL
4920001200	22-32	12,2	GALVANIZED STEEL
4920001300	26-38	12,2	GALVANIZED STEEL
4920001400	32-44	12,2	GALVANIZED STEEL
4920001500	38-50	12,2	GALVANIZED STEEL
4920001600	44-56	12,2	GALVANIZED STEEL
4920001700	50-65	12,2	GALVANIZED STEEL
4920001800	58-75	12,2	GALVANIZED STEEL
4920001900	68-85	12,2	GALVANIZED STEEL
4920002000	77-95	12,2	GALVANIZED STEEL
4920002100	87-112	12,2	GALVANIZED STEEL
4920002200	104-138	12,2	GALVANIZED STEEL
4920002300	130-165	12,2	GALVANIZED STEEL
492A200100	8-14	9	STAINLESS STEEL
492A200200	11-17	9	STAINLESS STEEL
492A200300	13-20	9	STAINLESS STEEL
492A200400	15-24	12,2	STAINLESS STEEL
492A200500	19-28	12,2	STAINLESS STEEL
492A200600	22-32	12,2	STAINLESS STEEL
482A200700	26-38	12,2	STAINLESS STEEL
492A200800	32-44	12,2	STAINLESS STEEL
492A200900	38-50	12,2	STAINLESS STEEL
492A201000	44-56	12,2	STAINLESS STEEL
492A201100	50-65	12,2	STAINLESS STEEL
492A201200	58-75	12,2	STAINLESS STEEL
92A201300	68-85	12,2	STAINLESS STEEL
492A201400	77-95	12,2	STAINLESS STEEL
492A201500	87-112	12,2	STAINLESS STEEL

## Ties "Aba" for sleeves



Code	Desc.	Tape height mm
492MA00100	32-44	12,2
492MA00200	38-50	12,2
492MA00300	44-56	12,2
492MA00400	50-65	12,2
492MA00500	58-75	12,2
492MA00600	68-85	12,2
492MA00700	77-95	12,2
492MA00800	87-112	12,2

- Internal elasticated strap 12.2 mm.
- Grafting tape steel double-profile rubber band.
- Excellent stability at high pressures and expansions.
- Suitable for pipes and hoses to large temperature range in turbocharged and intercooled and industrial uses.
- Ideal for silicone sleeves, our art. cod. 373 RS.

## Hose clamps "Mas"

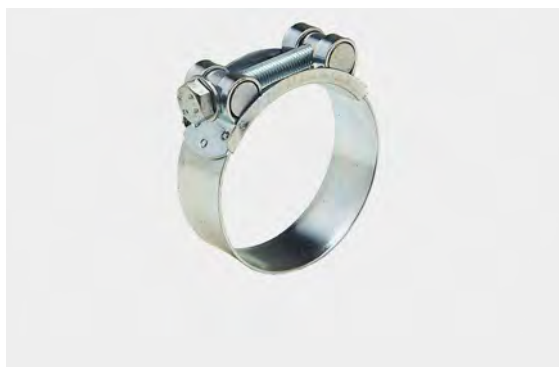

Code	Desc.	H tape
3090000100	29x31	20
3090000200	32x35	20
3090000300	36x39	20
3090000400	40x43	20
3090000500	44x47	22
3090000600	48x51	22
3090000700	52x55	22
3090000800	56x59	22
3090000900	60x63	22
3090001000	64x67	22
3090001100	68x73	24
3090001200	74x79	24
3090001300	80x85	24
3090001400	86x91	26
3090001500	92x97	24
3090001600	98x103	24
3090001700	104x112	24
3090001800	113x121	24
3090001900	122x130	24
3090002000	131x139	24
3090002100	140x148	26
3090002200	149x161	26
3090002300	162x174	26
3090002400	175x187	26
3090002500	188x200	26

- Solid collar tubes reinforced structure for agricultural use, water, sewage and sludge suction etc ..

## Universal clamps for constant velocity joints and steering headphones



- Stainless steel AISI 301 - en 10088-2.
- Two measures can cover a range from 20 to 120 mm.
- Quick to install and safe over time.
- Belt width 7mm.
- Thickness 0.5 mm.

Code	Desc.
5090002000	20-45
5090002010	45-120

## Pliers for band clamps for joints



- Pliers indicated for the pulling of the hose for constant velocity joints.
- Robust steel clamp 240 mm long.
- It equipped with a central pivot that during tightening of the clamp compresses the cap of the strap and secures the closure.
- With two paintings female 1/2" for a possible use of a torque wrench for a controlled tightening.
- For workshops and dealerships.

Code	Desc.
4430056615	1772

## Ties Panduit type stainless steel for joints



- Band clip in stainless steel AISI 304.
- The particular conformation of the padlock gives a guarantee of sealing and reliability.
- Particularly suitable for the tightening of the headphones of constant velocity joints and cables.
- Tightening with specific tools see our art. cod. 477 00 00830-83; 294 00 05760 to 2110; 491 00 01300-D1.

Code	Desc.	Width x length
2940085006	00594	4,6x201
2940085007	00595	4,6x360
2940085010	00598	4,6x520
2940085008	00596	7,9x201
2940085009	00597	7,9x360
2940085030	00618	7,9x520

## Pliers for clamps Inox type Panduit



- Caliper for steel straps width 4,6 and 7,9 mm.
- The special hardened steel jaws for better grip and an optimum tightening of the clamp and a precise cut of the same.

Code	Description
2940005760	2110

2

## Stainless Steel Cable Ties

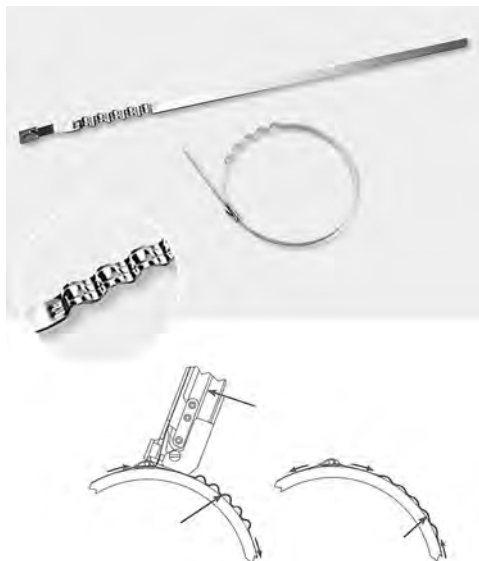

- Stainless steel clamps with new spring.
- The band remains permanently in traction.
- This spring system does not affect the tightness of 360° and also makes the clamp indispensable in the auto industry especially for the attachment of the headphones axle shafts.
- For all those hardware burdensome and also to join dissimilar materials.
- Factory generally and installers.

Code	Desc.
2940085070	00623-7.9x361
2940085080	00624-7.9x521

## Tool clamping metal clamps



- Utensil economic for the pulling of the metal clamps, the cutting of the band, at the end of tightening, is via twisting of the strap itself

Code	Desc.
4770000830	83

## Ties constant velocity joints Band-it



- Clamps stainless steel AISI 304, suitable for all the grooves of the headphones.
- Head very low, small footprint (see Duchy).
- Clamping system mechanical and friction that guarantees resistance and eliminates any interference phenomenon with electronic ABS.
- Tightening double given by punching the clip and the lapel clamp cut, they give maximum security.

Code	Desc.	Tape width x length. mm
2940085045	00619	6,3x254
2940085050	00620	6,3x419
2940085055	00621	6,3x572



## Pliers for clamps Band-it



- Specific tool for pulling and cutting ties constant velocity joints Band-it.
- The gripper is provided with a controller calibratable for tires hold or hard.
- The clamping system by punching gives maximum security seal the tie.

Code	Desc.
2940085060	00622

## Plugs, oil pan

2



**Application:**  
AUDI 180-100

Code	Desc. <i>Ø x pitch x wrench</i>
1900003400	14x1,5x19



**application:**  
OLD MOD. FIAT

Code	Desc. <i>Ø x pitch x wrench</i>
1900000100	22x1,5x17



**Application:**  
MERCEDES FUEL 240-250 350-500

Code	Desc. <i>Ø x pitch x wrench</i>
1900000300	12x1,5x13



**Application:**  
VW GOLF AUDI 80-100

Code	Desc. <i>Ø x pitch x wrench</i>
1900000400	14x1,5x19



**Application:**  
MISCELLANEOUS

Code	Desc. <i>Ø x pitch x wrench</i>
1900000600	20x1,5x12EI



**Application:**  
FIAT CROMA ALL TYPES AND THEMA

Code	Desc. <i>Ø x pitch x wrench</i>
1900001000	22x1,5x22



**Application:**  
126-127-131 PANDA 30-UNO TIPO-PUNTO TEMPRA-Y 10

Code	Desc. <i>Ø x pitch x wrench</i>
1900001400	22x1,5x12EI



**Application:**  
BMW-316 318-320-323 518-520-525 528

Code	Desc. <i>Ø x pitch x wrench</i>
1900002000	22x1,5x19



**Application:**  
FORD

Code	Desc. <i>Ø x pitch x wrench</i>
1900002300	16x1,5x13



**Application:**  
FORD FIESTA FIESTA GHIA

Code	Desc. <i>Ø x pitch x wrench</i>
1900002500	14x1,5x13

## Oil sump plugs



**Application:**  
MERCEDES 190E 200-250

Code	Desc. <i>Ø x pitch x wrench</i>
1900002700	14x1,5x13



**Application:**  
PEUGEOT 104 204-304-305 403-404-504  
505-605

Code	Desc. <i>Ø x pitch x wrench</i>
1900002900	16x1,5x10 QIC



**Application:**  
RENAULT 4-5

Code	Desc. <i>Ø x pitch x wrench</i>
1900003000	18x1,5x10 QI



**Application:**  
RENAULT 21 CLIO-TWINGO

Code	Desc. <i>Ø x pitch x wrench</i>
1900003100	16x1,5x8 QI



**Application:**  
SAAB 900 TURBO

Code	Desc. <i>Ø x pitch x wrench</i>
1900003200	14x1,5x13

## Plug oil sump duralumin



Code	Desc. Ø x pitch
1890000050	6x1
1890000070	8x1,25
1890000090	10x1
1890000100	10x1,25
1890000150	10x1,5
1890000170	12x1,25
1890000200	12x1,5
1890000300	14x1,5
1890000400	16x1,5
1890000500	18x1,5
1890000600	20x1,5
1890000700	22x1,5
1890000800	24x1,5

2

## Special caps for oil sump



- Special caps for modified oil sump in zinc and aluminum.
- Product Factory can be used on cars, trucks, commercial vehicles and earth moving according to the measures.
- Special caps with inner opening screw: you empty the tank without having to remove the cap.
- The replacement of these caps in the cups oil allows, in later use, to empty the tank without having to remove the cap risking damaging the hole, having to expand, and redo thread with saving time.
- All the plugs have a pitch of 1.5.

Code	Desc.	Diam. mm
1900004000	40-14x1,5	14
1900004100	41-16x1,5	16
1900004200	42-18x1,5	18
1900004300	43-20x1,5	20



## Traction springs



Code	Desc.	Ø filo mm	Ø Est. Molla mm	Tot. length spring mm.
2960002000	02	0,6	4,8	37



Code	Desc.	Ø filo mm	Ø Est. Molla mm	Tot. length spring mm.
2960002030	03	1,3	8,5	37



Code	Desc.	Ø filo mm	Ø Est. Molla mm	Tot. length spring mm.
2960002050	04	1,5	9,5	33



Code	Desc.	Ø filo mm	Ø Est. Molla mm	Tot. length spring mm.
2960002100	05	1,2	6,2	42



Code	Desc.	Ø filo mm	Ø Est. Molla mm	Tot. length spring mm.
2960002200	06	1,5	7	38,5



Code	Desc.	Ø filo mm	Ø Est. Molla mm	Tot. length spring mm.
2960002300	07	1,2	7,8	29

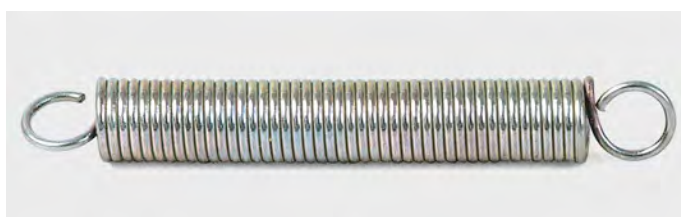

Code	Desc.	Ø filo mm	Ø Est. Molla mm	Tot. length spring mm.
2960002400	08	0,7	5	42



Code	Desc.	Ø filo mm	Ø Est. Molla mm	Tot. length spring mm.
2960002500	011	1	9,5	26



Code	Desc.	Ø filo mm	Ø Est. Molla mm	Tot. length spring mm.
2960002600	014	1	6	54



Code	Desc.	Ø filo mm	Ø Est. Molla mm	Tot. length spring mm.
2960002700	016	1,2	7,1	55,5



Code	Desc.	Ø filo mm	Ø Est. Molla mm	Tot. length spring mm.
2960002800	018	1,2	8	41



Code	Desc.	Ø filo mm	Ø Est. Molla mm	Tot. length spring mm.
2960002850	024	1,5	10	47,5



Code	Desc.	Ø filo mm	Ø Est. Molla mm	Tot. length spring mm.
2960002900	028	2,5	11,8	52,7



Code	Desc.	Ø filo mm	Ø Est. Molla mm	Tot. length spring mm.
2960003500	035	2,2	14,2	90



Code	Desc.	Ø filo mm	Ø Est. Molla mm	Tot. length spring mm.
2960004600	046	2,5	20,5	91

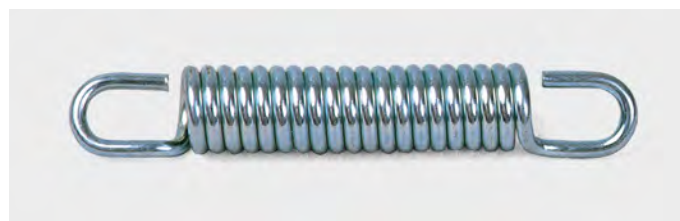

Code	Desc.	Ø filo mm	Ø Est. Molla mm	Tot. length spring mm.
2960003200	032	2,5	13	84

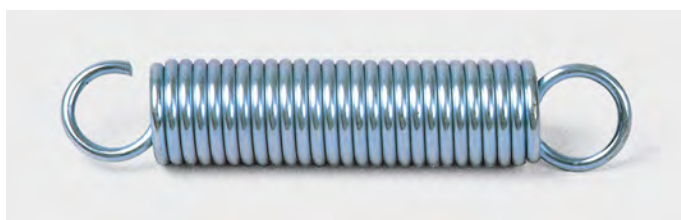

Code	Desc.	Ø filo mm	Ø Est. Molla mm	Tot. length spring mm.
2960004900	049	3	22,8	119



Code	Desc.	Ø filo mm	Ø Est. Molla mm	Tot. length spring mm.
2960003900	039	2	14	89



Code	Desc.	Ø filo mm	Ø Est. Molla mm	Tot. length spring mm.
2960005400	054	2,6	18	86,5



Code	Desc.	Ø filo mm	Ø Est. Molla mm	Tot. length spring mm.
2960004700	047	2,8	16,5	80,3

## Traction springs



Code	Desc.	Ø filo mm	Ø Est. Molla mm	Tot. length spring mm.
2960006000	060	2,5	20	109



Code	Desc.	Ø filo mm	Ø Est. Molla mm	Tot. length spring mm.
2960005000	050	2	14,8	119

2

## Tension spring assortment



- Contents: 13 sizes of springs from 02 to 054.
- Total 135 pieces.
- Supplied in a plastic carrying case our cod. 398 00 01900 ABH4.

Code	Desc.
2960100200	13

### Content kit

CODE	DESCRIPTION	PCS
296 00 02000	02	20
296 00 02030	03	20
296 00 02050	04	10
296 00 02100	05	10
296 00 02200	06	10
296 00 02300	07	10
296 00 02400	08	10
296 00 02600	014	10
296 00 02800	018	10
296 00 02900	028	10
296 00 03200	032	5
296 00 04600	046	5
296 00 05400	054	5



2

## Filmec fillets

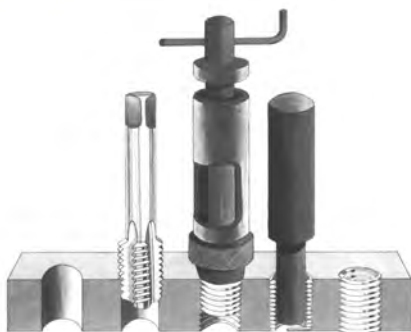

- Thread insert is intended to produce or regenerate threaded seats subjected to high stress static or dynamic even at elevated temperatures.
- Suitable for frequent screwing and in conditions of risk to corrosion, it has the appearance of a spring with a lozenge-shaped section.
- Material: Stainless steel.
- NB: the height indicated on the price list, indicating the height of the thread placed.
- Measures see price list.

### How mounts

Mounting a FILMEC requires four steps:

1. The drilling of the required diameter, and 'preferable not to make chamfers at the hole.
2. Tapping through a special tap FILMEC.
3. Mass posing thread using a special tool.
4. The rupture of the shank of drive by means of a special punch or pliers.

Code	Desc.
42096*****	*****

## Kit fillets Filmec



- Assorted fillets Filmec.
- Suitable for car and motorcycle workshops, body shops generally.
- Particularly effective in reproducing or regenerating threaded seats damaged or worn by time.
- Supplied in a practical plastic case our code 3980001800.
- Total: 90 pieces with briefcase.

Code	Description
4209604800	1-kit Filmec fillets

Contenuto kit

CODE	DESCRIPTION	PCS
420 96 00100	5 x 0,8-H 7,5	5
420 96 00200	5x0,8-H 10	5
420 96 00400	6x1-H 9	5
420 96 00500	6x1-H 12	5
420 96 00600	7x1-H 10,5	5
420 96 00900	8x1,25-H 8	5
420 96 01000	8x1,25-H 12	5
420 96 01100	8x1,25-H 16	5
420 96 01200	8x1,25-H 20	5
420 96 01900	10x1,25-H 10	5
420 96 02000	10x1,25-H 15	5
420 96 02200	10x1,5-H 15	5
420 96 02300	10x1,5-H 20	5
420 96 02400	12x1,25-H 12	5
420 96 02700	12x1,5-H 12	5
420 96 02850	12x1,75-H 18	5
420 96 03000	14x1,25-H 14	5
420 96 03100	14x1,25-H 21	5



## Males Filmec



- Male-specific locations of the threads FILMEC.

Code	Desc. Ø x pitch	Ø Foratura mm
4430032600	377 - 5x0,8	5,20
4430032610	377 - 6x1	6,30
4430032620	377 - 7x1	7,30
4430032630	377 - 8x1	8,30
4430032640	377 - 8x1,25	8,40
4430032660	377 - 10x1	10,25
4430032670	377 - 10x1,25	10,40
4430032680	377 - 10x1,5	10,50
4430032690	377 - 12x1,25 x cand.	12,35
4430032695	377 - 12x1,25	12,35
4430032700	377 - 12x1,5	12,50
4430032710	377 - 12x1,75	12,50
4430032720	377 - 14x1,25 x cand.	14,40
4430032725	377 - 14x1,25	14,40
4430032730	377 - 14x1,5	14,50
4430032740	377 - 14x2	14,50
4430032750	377 - 16x1,5	16,50
4430032752	377 - 16x2	16,50
4430032760	377 - 18x1,5	18,50



## Tool for laying Filmec



- Tool for laying fillets FILMEC.
- The body of the installer FILMEC can be used across multiple steps or diameters using the spare parts for installers.
- In order to do this we must, however, comply with the N ° shown on the tool.
- Example: 443 00 32810 378-6x1 installer # 2 + 420 03 00300 8x1.25.
- In this way the same installer is usable on multiple diameters.
- \* Specific to the threads of the spark plugs.
- \*\* There are no spare parts.

Code	Desc. Ø x pitch	Posatore
4430032800	378 - 5x0,8	1
4430032810	378 - 6x1	2
4430032820	378 - 7x1	2
4430032830	378 - 8x1	2
4430032840	378 - 8x1,25	2
4430032860	378 - 10x1	3
4430032870	378 - 10x1,25	3
4430032880	378 - 10x1,5	3
4430032895	378 - 12x1,25	3
4430032900	378 - 12x1,5	3
4430032910	378 - 12x1,75	3
4430032925	378 - 14x1,25	4
4430032930	378 - 14x1,5	4
4430032940	378 - 14x2	4
4430032890	378 - 12x1,25 *	3
4430032920	378 - 14x1,25 *	4
4430032950	378 - 16x1,5 **	-
4430032952	378 - 16x2 **	-
4430032960	378 - 18x1,5 **	-
4430032962	378 - 18x2,5 **	-

## Spare parts for installers Filmecc

2



Code	Desc. Ø x pitch
4200300050	5 x 0,8
4200300100	6 x 1
4200300200	7 x 1
4200300250	8 x 1
4200300300	8 x 1,25
4200300400	10 x 1,25
4200300500	10 x 1,5
4200300600	12 x 1,25
4200300700	12 x 1,5
4200300800	12 x 1,75
4200300900	14 x 1,5
4200301000	16 x 1,5

- Auction more head parts for installers art. 443 00 desc. 378 ...

## Complete kit Filmecc candles



- Full packaging of fillets and fitter for fillets of candles motorcycle.
- Avoids the replacement of the engine parts (cylinder head, crankcase, etc ..) from the vehicle.

Code	Desc.	Measure
4220000100	7540	14x1,25

CONTENUTO
N° 1 POSATORE FILMECC CANDELE 14x1,25
N° 1 MASCHIO FILMECC CANDELE 14x1,25
N° 10 FILETTI FILMECC 14x1,25 H 7,5
N° 10 FILETTI FILMECC 14x1,25 H 10,5
N° 10 FILETTI FILMECC 14x1,25 H 18

## Complete kit Filmecc candles



- Full packaging of fillets and fitter for fillets of candles motorcycle.
- Avoids the replacement of the engine parts (cylinder head, crankcase, etc ..) from the vehicle.

Code	Desc.	Measure
4220000200	7541	12x1,25

CONTENUTO
N° 1 POSATORE FILMECC CANDELE 12x1,25
N° 1 MASCHIO FILMECC CANDELE 12x1,25
N° 10 FILETTI FILMECC 12x1,25 H 10,5
N° 10 FILETTI FILMECC 12x1,25 H 18

## Repair Kit Filmec 4 diameters



- Complete kit for repairs with fillets Filmec essential for maintenance in factories, garages, workshops etc .. To restore any tapping done incorrectly, with low resistance, deteriorated etc ..

2

Code	Desc.	Diameters
4230000100	9130	6X1 - 8X1,25 10X1,25 - 12X1,5

CONTENUTO	CONTENUTO
N° 1 POSATORE FILMEC PER Ø 6 E Ø 8 N° 1 POSATORE FILMEC PER Ø 10 E Ø 12 N° 1 TRASCINATORE 6x1 N° 1 TRASCINATORE 8x1,25 N° 1 TRASCINATORE 10x1,25 N° 1 TRASCINATORE 12x1,5 N° 1 MASCHIO FILMEC 6x1 N° 1 MASCHIO FILMEC 8x1,25 N° 1 MASCHIO FILMEC 10x1,25 N° 1 MASCHIO FILMEC 12x1,5	N° 1 ATTREZZO ROTTURA CODOLO Ø 6 N° 1 ATTREZZO ROTTURA CODOLO Ø 8 N° 1 ATTREZZO ROTTURA CODOLO Ø 10 N° 1 ATTREZZO ROTTURA CODOLO Ø 12 N° 1 ATTREZZO RIMOZIONE FILETTI N° 10 FILETTI FILMEC 6x1 H 9 N° 10 FILETTI FILMEC 8x1,25 H 12 N° 10 FILETTI FILMEC 10x1,25 H 15 N° 10 FILETTI FILMEC 12x1,5 H 15

## Repair Kit mono diameter Filmec



- Plastic box for repair with fillets FILMEC.
- Full installer, and male fillets.

Code	Desc. Ø x pitch	Content
4230000150	9131 - 5x0,8	1 INSTALLER 1 MALE 6 FILLETS H 7,5
4230000200	9131 - 6x1	1 INSTALLER 1 MALE 6 FILLETS H 9
4230000250	9131 - 8x1,25	1 INSTALLER 1 MALE 5 FILLETS H 12
4230000260	9131 - 9x1,25	1 INSTALLER 1 MALE 5 FILLETS H 13,5
4230000300	9131 - 10x1,5	1 INSTALLER 1 MALE 5 FILLETS H 15
4230000350	9131 - 10x1,25	1 INSTALLER 1 MALE 5 FILLETS H 15

## Bushings self-tapping for light alloys

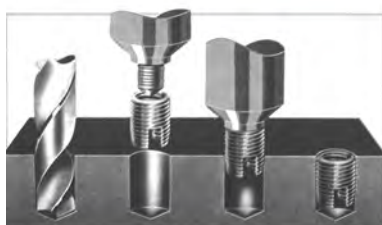

Misura interna	Misura esterna	Lunghezza mm	Profondità min. foro mm	Diametro min. foro mm	Diametro max foro mm
M 3X0,5	M 5X0,5	6	8	4,6	4,7
M 4X0,7	M 6,5X0,75	8	10	6,0	6,1
M 5X0,8	M 8X1,0	10	13	7,3	7,5
M 6X1,0	M 9X1,0	12	15	8,1	8,6
M 8X1,25	M 12X1,5	15	18	10,6	11,4
M 10X1,5	M 14X1,5	18	22	12,6	13,4
M 12X1,75	M 16X1,5	22	25	14,8	15,2
M 14X2,0	M 18X1,5	24	28	16,8	17,2

- Threaded Inserts applicable on light alloys, cast iron and synthetic materials allow the creation of these materials Tenri threads resistant and durable with perfect sealing of screws applied.
- The appropriate bevels make compasses can automaschiarsi media, with no need to thread them in advance before the installation.
- Similarly they can be used on these materials for the reconstruction of damaged threads.
- For use and 'you must provide the contractor the amount corresponding to the bushings.

Code	Desc.	Ø internal
4660000100	3X0,5-H6	M 3X0,5
4660000200	4X0,7-H8	M 4X0,7
4660000300	5X0,8-H10	M 5X0,8
4660000400	6X1,0-H12	M 6X1,0
4660000600	8X1,25-H15	M 8X1,25
4660000700	10X1,5-H18	M 10X1,5
4660000800	12X1,75-H22	M 12X1,75
4660000900	14X2,0-H24	M 14X2,0

## Installers for tapping bushings



- Installers manual insertion and laying of self-tapping bushes in light alloys, cast iron and plastics.
- For the use of the bushings you must use the contractor of that amount.
- These layers are used through a simple mandamaschi to square drive.

Code	Desc.	For bushings
4670000100	3X0,5	466 00 00100-M 3X0,5
4670000200	4X0,7	466 00 00200-M 4X0,7
4670000300	5X0,8	466 00 00300-M 5X0,8
4670000400	6X1,0	466 00 00400-M 6X1,0
4670000500	8X1,25	466 00 00600-M 8X1,25
4670000600	10X1,5	466 00 00700-M 10X1,5
4670000700	12X1,75	466 00 00800-M 12X1,75
4670000800	14X2,0	466 00 00900-M 14X2,0





## Electrical parts

Wirings . . . . .	pag. 278	Insulating sheaths and electrical cables . . . . .	pag. 354
Fuses and fuse holders . . . . .	pag. 282	Lamps for motor vehicles and work lights . . . . .	pag. 374
Connectors . . . . .	pag. 300	Lamps for civil and industrial use . . . . .	pag. 410
Terminals and lugs . . . . .	pag. 320	Battery . . . . .	pag. 420
Clamps . . . . .	pag. 345		

## Electronic windscreen antenna



- Electronic windscreen antenna.

Code	Desc.	Adaptability
3180000030	206165	UNIVERSAL

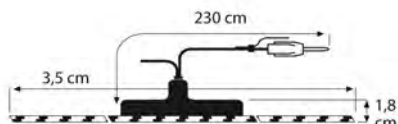

Tecnical Features	
Circuit	S.M.D.
Guadagno	AM 20 dB FM 14 dB
Capacity	pf 75 ÷ 10%
Funzionamento	6 to 13 V

## Roof Aerial



- Roof antenna with cable extension L. 2.30 m.
- Oval base.

Code	Desc.
3180000040	206166

## Rod spare antenna



- Rod fiber
- With thread M5 / M6
- Applicable on all cars.

Code	Desc. / Length	Thread
3180010200	740103-17cm	M5/M6
3180010180	740101-22cm	M5
3180010190	740102-40cm	M5
3180010192	740156-40cm	M5/M6

## Aerial cables and accessories



- Antenna extension cable with shielding 95%.

Code	Description	Length
3180000100	250010 senza condensatore	60 cm
3180001900	250121 con condensatore	150 cm



- Cable antenna adapter ISO, DIN car radio system.

Code	Desc.	Length
3180000500	250100	10 cm



- Jack plug parts for antenna extension

Code	Desc.
3180002500	470001



- Jack plug parts for extension antenna (Bosch type).

Code	Desc.
3180002700	470130



- Jack parts for antenna extension angle 90 ° (Bosch type).

Code	Desc.
3180002900	470139



- Interface ISO power + 4 speakers.

Code	Desc.
3180008100	740075



- Antenna adapter.
- Connector pipe + 90 ° aerial socket standard.

Code	Desc.
3180002600	470002



- Antenna adapter cable

Code	Desc.
3180010110	740096/ISO
3180010120	740096/DIN

## Wiring for ISO Connectors



- Universal harness for cars with ISO connectors.
- Power + 4 speakers.

Code	Desc.
3180005805	740050/ISO



- Universal harness for cars with connectors ASI.
- Power + 4 speakers.

Code	Desc.
3180005810	740050/ASI

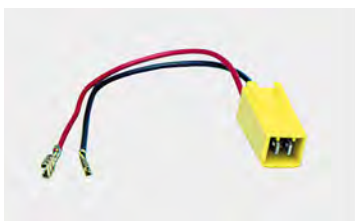

- Speaker cable.
- Internal connections doors.

Code	Desc.
3180000900	250106

## Wiring for Ford

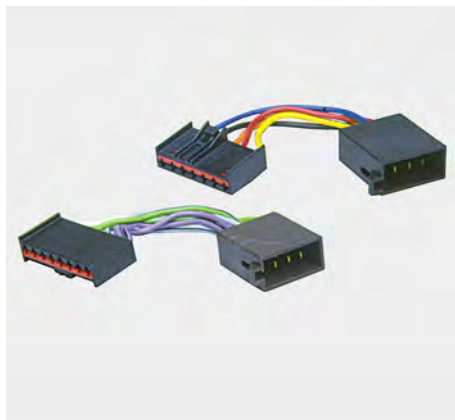

- Harness ISO power + 4 speakers original car radio adapter for Ford cars is not prepared.

Code	Desc.
3180000006	1072261/ISO

## Wiring for Opel, VW and Smart



- Wiring OPEL 2004 SMART Forfour with SIX radio.
- VW wiring 2003.
- Power + 4 speakers.

Code	Desc.
3180010230	740106/ISO

## Pushbutton Switches

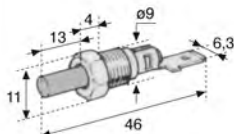

Code	Desc.	Applications
3200009480	9480	FIAT - portiere

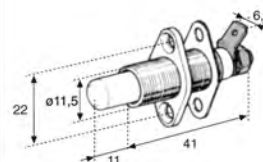

Code	Desc.	Applications
3200009570	9570	Systems anti-theft doors, hatchbacks

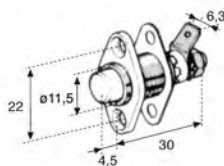

Code	Desc.	Applications
3200009580	9580	Systems anti-theft doors, hatchbacks



## Double toggle switch with 4 cable screw



Code	Desc.	Nr. wires
3200000100	210164	4

## Signal lights in LED diode with wires



- Screw fixing.
- Color: Red flashing.

Code	Desc.	Nr. wires	Voltage (V)
3200000200	50214	2	12



- Pressure fixing.
- Color: Red flashing.

Code	Desc.	Nr. wires	Voltage (V)
3200000300	50222	2	12

## Perforated galvanized steel rods

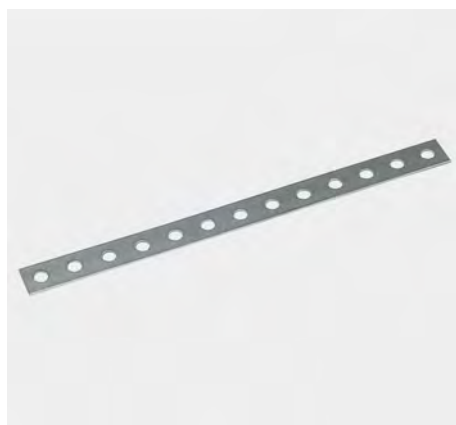

Code	Desc.	Length mm	Width mm	Thickness mm
3210000100	200x15x1,5	200	15	1,5
3210000200	250x15x1,5	250	15	1,5
3210000300	300x15x1,5	300	15	1,5
3210000400	200x20x2	200	20	2,0
3210000600	250x20x2	250	20	2,0
3210000700	300x20x2	300	20	2,0

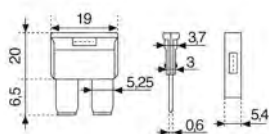
**Standard ΑΣΦΑΛΕΙΕΣ ΔΙΧΑΛΩΤΕΣ**

Code	Descriz. <i>corr. nom. (In)</i>	Body color
3520100010	1 A	BLACK
3520100020	2 A	GREY
3520100100	3 A	GREY
3520100150	4 A	PINK
3520100200	5 A	BEIGE
3520100300	7.5 A	BROWN
3520100400	10 A	RED
3520100500	15 A	BLUE
3520100600	20 A	YELLOW
3520100700	25 A	NEUTRAL
3520100800	30 A	GREEN
3520100840	40 A	ORANGE

**Standard ΔΙΧΑΛΩΤΕΣ ΜΕ Led**

- In accordance with the general rules SAE J 1284
- They have an LED that lights up following the fuser interruption
- Self-extinguishing
- Dimensions as standard UNI

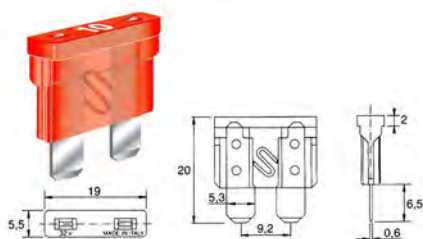

Code	Descriz. <i>corr. nom. (In)</i>	Body color
3520102710	3A fusibile lama Uni con led	VIOLET
3520102715	5A fusibile lama Uni con led	BEIGE
3520102720	7,5A fusibile lama Uni con led	BROWN
3520102725	10A fusibile lama Uni con led	RED
3520102730	15A fusibile lama Uni con led	LIGHT BLUE
3520102735	20A fusibile lama Uni con led	YELLOW
3520102740	25A fusibile lama Uni con led	TRANSPARENT
3520102745	30A fusibile lama Uni con led	GREEN

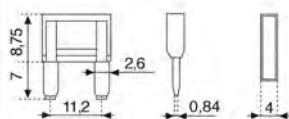
**MINI ΔΙΧΑΛΩΤΕΣ ΑΣΦΑΛΕΙΕΣ**

Code	Descriz. <i>corr. nom. (In)</i>	Body color
3520101800	2 A	GREY
3520101900	3 A	VIOLET
3520102000	4 A	PINK
3520102100	5 A	BEIGE
3520102200	7.5 A	BROWN
3520102300	10 A	RED
3520102400	15 A	BLUE
3520102500	20 A	YELLOW
3520102600	25 A	NEUTRAL
3520102700	30 A	GREEN

## Micro blade fuses with Led



- In accordance with the general rules SAE J 1284
- They have an LED that lights up following the fuser interruption
- Self-extinguishing
- Dimensions as standard UNI.

3

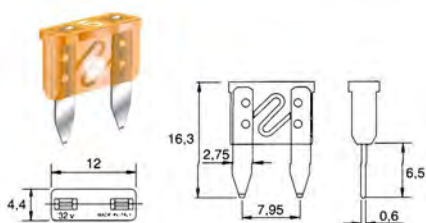

Code	Descriz. <i>corr. nom. (In)</i>	Body color
3520102750	2A micro fusibile con led	GREY
3520102755	3A micro fusibile con led	VIOLET
3520102760	4A micro fusibile con led	PINK
3520102765	5A micro fusibile con led	BEIGE
3520102770	7,5A micro fusibile con led	BROWN
3520102775	10A micro fusibile con led	RED
3520102780	15A micro fusibile con led	LIGHT BLUE
3520102785	20A micro fusibile con led	YELLOW
3520102790	25A micro fusibile con led	WHITE
3520102795	30A micro fusibile con led	GREEN

## Micro2 blade fuses



- The 32 V micro2 fuses are the new standard for vehicle circuit protection.

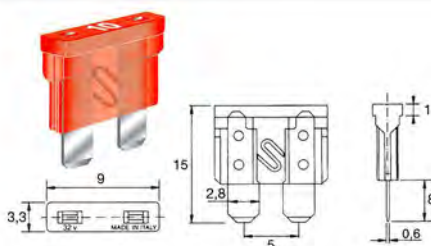

Code	Descriz. <i>corr. nom. (In)</i>	Body color
3520102800	5A micro2 fuse 32V	BEIGE
3520102805	7,5A micro2 fuse 32V	BROWN
3520102810	10A micro2 fuse 32V	RED
3520102815	15A micro2 fuse 32V	LIGHT BLUE
3520102820	20A micro2 fuse 32V	YELLOW
3520102825	25A micro2 fuse 32V	WHITE
3520102830	30A micro2 fuse 32V	GREEN

## Maxi blade fuses

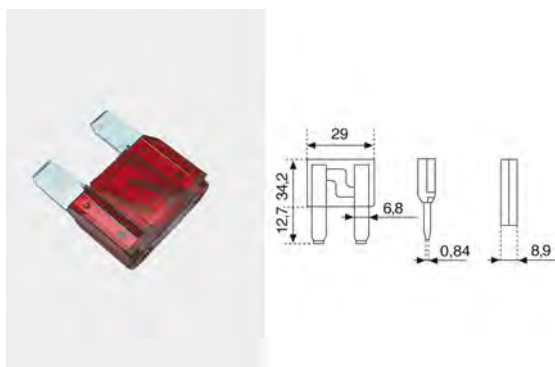

Code	Descriz. <i>corr. nom. (In)</i>	Body color
3520101000	20 A	YELLOW
3520101100	30 A	GREEN
3520101200	40 A	ORANGE
3520101300	50 A	RED
3520101400	60 A	BLUE
3520101500	70 A	BROWN
3520101600	80 A	NEUTRAL
3520101700	100 A	VIOLET

- Designed for short circuit protection of electrical flow in which high values of rated current (In).

## Micro3 blade fuses

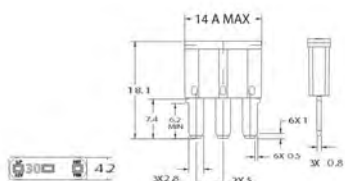

- The 32 V micro3 fuses are the new standard for vehicle circuit protection.

Code	Descriz. <i>corr. nom. (In)</i>	Body color
3520102835	5A micro3 fuse	Beige
3520102840	7,5A micro3 fuse	Brown
3520102845	10A micro3 fuse	Red
3520102850	15A micro3 fuse	Light blue

## Low-profile fuses



Code	Desc.	Color	Amperage (A)
3580002900	2A	GREY	2
3580002910	3A	VIOLET	3
3580002920	4A	PINK	4
3580002930	5A	BEIGE	5
3580002940	7,5A	BROWN	7,5
3580002950	10A	RED	10
3580002960	15A	BLUE	15
3580002970	20A	YELLOW	20
3580002980	25A	NATURAL	25
3580002990	30A	GREEN	30

- Blade fuses, for Japanese cars.
- The particular shape of the fuse contact makes it suitable for replacement of the car market Eastern Europe.
- Max fuse size: 11x9 mm.

## Cylindrical fuses plastic foil

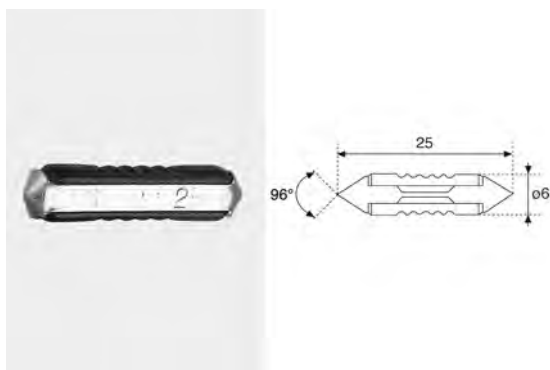

Code	Descriz. <i>corr. nom. (In)</i>	Body color	Original ref.
3500100100	5 A - L 25	YELLOW	FIAT 9.91806
3500000100	8 A - L 25	BLACK	FIAT 9.91806
3500100200	8 A - L 25	WHITE	DIN72581
3500000150	10 A - L 25	WHITE	-
3500000200	16 A - L 25	GREEN	FIAT 9.91806
3500100300	16 A - L 25	RED	DIN72581
3500000300	25 A - L 25	BROWN	FIAT 9.91806
3500100400	25 A - L 25	BLUE	DIN72581
3500000400	40 A - L 25	RED	-

- Available in the original references: Fiat, DIN.



## Cylindrical fuses fast glass

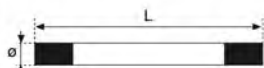

- Available in two sizes, different amperage, voltage to 12-24 V.

Code	Descriz. <i>corr. nom. (In)</i>	Dim. mm
3530000060	500 MA	5 x 20
3530000100	1 A - L 20	5 x 20
3530000200	2 A - L 20	5 x 20
3530000300	3 A - L 20	5 x 20
3530000400	4 A - L 20	5 x 20
3530000500	5 A - L 20	5 x 20
3530000600	6 A - L 20	5 x 20
3530000700	10 A - L 20	5 x 20
3530000720	20 A - L 20	5 x 20
3530000730	1 A - L 32	6.3 x 32
3530000735	2 A - L 32	6.3 x 32
3530000750	3 A - L 32	6.3 x 32
3530000800	5 A - L 32	6.3 x 32
3530000900	8 A - L 32	6.3 x 32
3530001000	10 A - L 32	6.3 x 32
3530001100	16 A - L 32	6.3 x 32
3530001150	20 A - L 32	6.3 x 32
3530001200	25 A - L 32	6.3 x 32
3530001300	30 A - L 32	6.3 x 32



## Fuses for Japanese cars with female coupling series AS

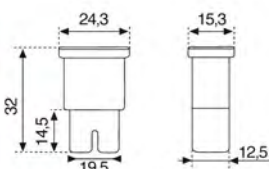

- Mounted group cars: Chrysler, Daihatsu, Ford, Hunday, Kia, Mazda, Mitsubishi, Nissan, Rover, Ss. Yong, Subaru, Suzuki, Toyota, Vauxhall.

Code	Descriz. <i>corr. nom. (In)</i>	Body color	Series
3580000050	20 A - FEMALE	LIGHT BLUE	AS
3580000100	30 A - FEMALE	PINK	AS
3580000200	40 A - FEMALE	GREEN	AS
3580000250	50 A - FEMALE	RED	AS
3580000300	60 A - FEMALE	YELLOW	AS
3580000310	80 A - FEMALE	BLACK	AS
3580000320	100 A - FEMALE	BLUE	AS

## Fuses for Japanese cars with male connection series B/BT

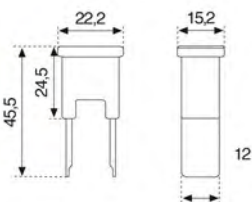

- Mounted group cars: Ford, Hyundai, Mazda, Mitsubishi, Nissan, Rover, Ss. Yong, Suzuki, Toyota, Vauxhall.

Code	Descriz. <i>corr. nom. (In)</i>	Body color	Series
3580000400	30 A - MALE	PINK	B/BT
3580000420	40 A - MALE	GREEN	B/BT
3580000440	50 A - MALE	RED	B/BT
3580000500	60 A - MALE	YELLOW	B/BT
3580000550	70 A - MALE	GREY	B/BT
3580000600	80 A - MALE	BLACK	B/BT
3580000700	100 A - MALE	BLUE	B/BT

## Fuses for Japanese cars with female coupling and retention

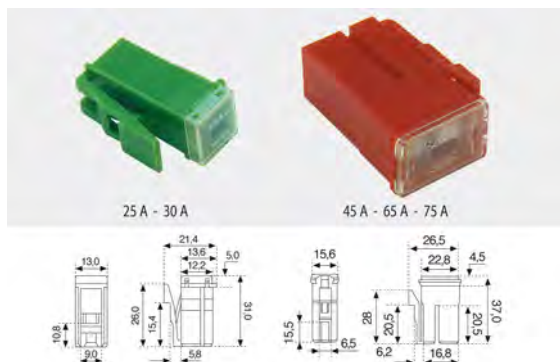

- Mounted group cars: Ford, Honda, Nissan, Subaru.

Code	Descriz. <i>corr. nom. (In)</i>	Body color	Series
3580002200	25 A - R-FEMALE	BROWN	D
3580002300	30 A - R-FEMALE	GREEN	D
3580002400	45 A - R-FEMALE	RED	E
3580002600	75 A - R-FEMALE	GREY	E

## Mini fuses for Japanese cars MF14 series Jcase

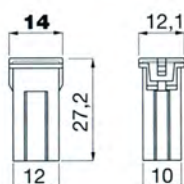

- Female coupling.
- The different colors identify the different amperage.
- With dimensions of 14 mm.

Code	Descriz. <i>corr. nom. (In)</i>	Color
3580002700	20A-MF14-FEMALE	LIGHT BLUE
3580002710	30A-MF14-FEMALE	PINK
3580002720	40A-MF14-FEMALE	GREEN
3580002730	50A-MF14-FEMALE	RED
3580002740	60A-MF14-FEMALE	YELLOW

## Mini fuses for Japanese cars MF18 series F

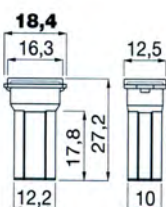

- Female coupling.
- The different colors identify the different amperage.
- With dimensions of 18 mm.

Code	Descriz. <i>corr. nom. (In)</i>	Color
3580002800	30A-MF18-FEMALE	PINK
3580002810	40A-MF18-FEMALE	GREEN

## Japanese fuses Jcase M series



- Reduced Series but same attack of normal JCASE series, Also mounted in the first plant of European cars such as Ford-Fiat-Chrysler group.

Code	Descriz. <i>corr. nom. (In)</i>	Body color
3580003035	20 A Mini fuse Jcase	Light blue
3580003040	25 A Mini fuse Jcase	White
3580003045	30 A Mini fuse Jcase	Pink
3580003050	40 A Mini fuse Jcase	Green
3580003055	50 A Mini fuse Jcase	Red
3580003060	60 A Mini fuse Jcase	Yellow

## Mega fuses for car

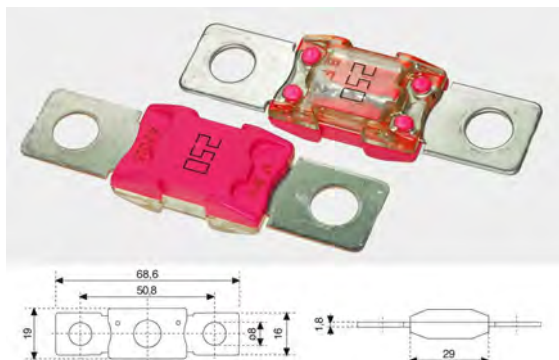

- Fuses mega 32V indicated for the protection of batteries and alternators.

Code	Descriz. <i>corr. nom. (In)</i>	Body color
3580100100	100 A	Yellow
3580100200	125 A	Green
3580100300	150 A	Orange
3580100400	200 A	Blue
3580100410	225 A	Beige
3580100420	250 A	Pink
3580100500	300 A	Grey
3580100600	400 A	Violet
3580100610	500 A - specifically for stralis	Brown

## Fuses midi for car

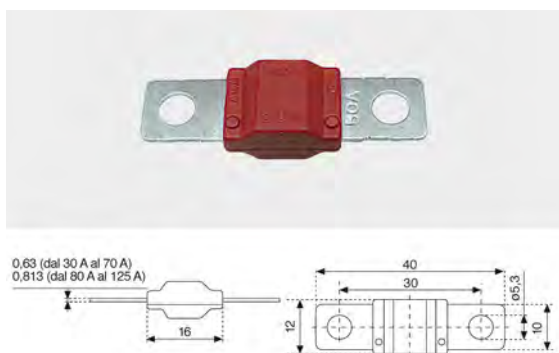

- Midi 32V socket fuses with Bolted alternative to maxi fuses and tape.
- Fuse inserted in our art. 354 00 01900-53055.

Code	Descriz. <i>corr. nom. (In)</i>	Body color
3580200050	30 A	PINK
3580200100	40 A	GREEN
3580200150	50 A	RED
3580200200	60 A	YELLOW
3580200250	70 A	BROWN
3580200300	80 A	WHITE
3580200350	100 A	BLUE
3580200400	125 A	ORANGE

## 80 Volt fuses with ceramic protection for battery vehicles



- The band fuses with ceramic protection are suitable for battery-powered vehicles, such as forklifts.
- With window for visual inspection for the fusion elements.

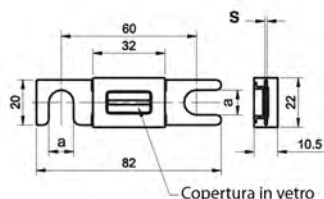

Code	Description	Ampere
3580003000	50 A ceramic fuse	50
3580003005	80 A ceramic fuse	80
3580003008	100 A ceramic fuse	100
3580003010	150 A ceramic fuse	150
3580003015	250 A ceramic fuse	250
3580003020	355 A ceramic fuse	355
3580003025	400 A ceramic fuse	400
3580003030	500 A ceramic fuse	500

## Fuses tape



Code	Descriz. <i>corr. nom. (In)</i>
3490000400	25 A
3490000030	30 A
3490000040	40 A
3490000100	50 A
3490000120	60 A
3490000200	80 A
3490000300	100 A



- Made from zinc ribbon with shiny surface in accordance with DIN 72581/2.
- To protect circuits crossed by high current such as diesel glow plugs, alternators, starters, air conditioning, automatic transmission, power seats.



## Assortment fuses various



- Contents: 16 bars of laminated cylindrical fuses 8 to 40A, DIN 5 to 25A, 40 and 50A diesel cars, EEC standards 7.5 to 30A.
- Total 400 pieces.
- Supplied in a plastic carrying case our cod. 398 00 01900 ABH4.

Code	Desc.
3500300100	16

Contenuto kit

CODICE	DESCRIZIONE	Q.tà
3500000300	25A-L25-FUSIBILE LAMELLARE	25
3500000400	40A-L25-FUSIBILE LAMELLARE	25
3500100100	5A-L25-FUSIBILE DIN V.TEDESCHE	25
3500100200	8A-L25-FUSIBILE DIN V.TEDESCHE	25
3500100400	25A-L25-FUSIBILE DIN V.TEDESC.	25
3490000100	50A-FUSIBILE VETTURE DIESEL	25
3520100300	7.5A-FUSIBILE NORME CEE	25
3520100400	10A -FUSIBILE NORME CEE	25
3520100500	15A -FUSIBILE NORME CEE	25
3520100600	20A -FUSIBILE NORME CEE	25
3520100700	25A -FUSIBILE NORME CEE	25
3520100800	30A -FUSIBILE NORME CEE	25
3490000040	40A-FUSIBILE VETTURE DIESEL	25
3500000200	16A-L25-FUSIBILE LAMELLARE	25
3500000100	8A-L25 -FUSIBILE LAMELLARE	25
3500100300	16A-L25-FUSIBILE DIN V.TEDESC.	25

## Assortment blade fuses EEC standards



- Contents: 12 measures of fuses from 1A to 40A EEC standards.
- Total 120 pieces.
- Supplied in a plastic carrying case our cod. 398 00 01700 200.

Code	Desc.
3520200100	12

Contenuto kit

CODICE	DESCRIZIONE	Q.tà
3520100020	2A -FUSIBILE NORME CEE	10
3520100010	1A -FUSIBILE NORME CEE	10
3520100100	3A -FUSIBILE NORME CEE	10
3520100150	4A -FUSIBILE NORME CEE	10
3520100200	5A -FUSIBILE NORME CEE	10
3520100300	7.5A-FUSIBILE NORME CEE	10
3520100400	10A -FUSIBILE NORME CEE	10
3520100500	15A -FUSIBILE NORME CEE	10
3520100600	20A -FUSIBILE NORME CEE	10
3520100700	25A -FUSIBILE NORME CEE	10
3520100800	30A -FUSIBILE NORME CEE	10
3520100840	40A-FUSIBILE NORME CEE	10

## Assortment micro blade fuses



- Content: 12 measures micro blade fuses 2A to 30A
- Total 60 pieces
- Supplied in a plastic carrying case n / s cod. 398 00 01 700 200

Code	Desc.
3520200300	12

**Contenuto kit**

CODICE	DESCRIZIONE	Q.tà
3520101800	2A -MICROFUSIBILE A LAMA	5
3520101900	3A -MICROFUSIBILE A LAMA	5
3520102000	4A -MICROFUSIBILE A LAMA	5
3520102100	5A -MICROFUSIBILE A LAMA	5
3520102200	7.5A -MICROFUSIBILE A LAMA	5
3520102300	10A -MICROFUSIBILE A LAMA	10
3520102400	15A -MICROFUSIBILE A LAMA	25
3520102500	20A -MICROFUSIBILE A LAMA	5
3520102600	25A -MICROFUSIBILE A LAMA	5
3520102700	30A -MICROFUSIBILE A LAMA	5

## Assortment maxi blade fuses



- Contents: 12 measurements max plug fuse 20A 100A has.
- Total 24 pieces.
- Supplied in plastic case our cod. 398 00 01700 200.

Code	Desc.
3520200200	12

**Contenuto kit**

CODICE	DESCRIZIONE	Q.tà
3520101000	20A -MAXIFUSIBILE A LAMA	2
3520101100	30A -MAXIFUSIBILE A LAMA	2
3520101200	40A -MAXIFUSIBILE A LAMA	2
3520101300	50A -MAXIFUSIBILE A LAMA	2
3520101400	60A -MAXIFUSIBILE A LAMA	4
3520101500	70A -MAXIFUSIBILE A LAMA	4
3520101600	80A -MAXIFUSIBILE A LAMA	4
3520101700	100A -MAXIFUSIBILE A LAMA	4

## Assorted glass fuses



- Contents: 12 sizes of glass fuses from 1A to 10A length 20mm 3A to 25A length 32mm.
- Total 240 pieces.
- Supplied in a plastic carrying case our cod. 398 00 01700 200.

Code	Desc.
3530100100	12

Contenuto kit

CODICE	DESCRIZIONE	Q.tà
3530000100	1A-L20 -FUSIBILE VETRO	20
3530000200	2A-L20 -FUSIBILE VETRO	20
3530000300	3A-L20 -FUSIBILE VETRO	20
3530000500	5A-L20 -FUSIBILE VETRO	20
3530000600	6A-L20 -FUSIBILE VETRO	20
3530000700	10A-L20-FUSIBILE VETRO	40
3530000750	3A-L32 -FUSIBILE VETRO	20
3530000800	5A-L32 -FUSIBILE VETRO	20
3530001000	10A-L32-FUSIBILE VETRO	20
3530001100	15A-L32-FUSIBILE VETRO	20
3530001200	25A-L32-FUSIBILE VETRO	20

## Fuse holder steering wheel to fuse plastic foil



- Fuse holder in plastic with connection cables for female faston step 6.3, bayonet.
- For fuses plastic foil our cod. 350 00, 350 01 l. 25 mm.

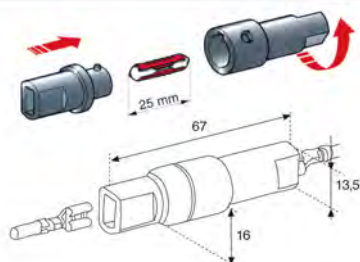

Code	Desc.
3540000700	53038

## Fuse holder steering wheel to fuse plastic foil



- Fuse holder in plastic material with tightening the thumbscrew cables, bayonet lock.
- For fuses plastic foil our cod. 350 00, 350 01 l. 25 mm.

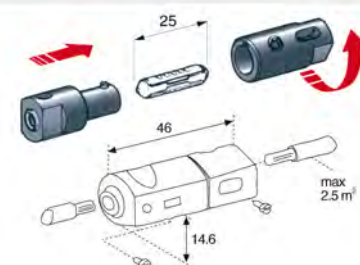

Code	Desc.	Cable sec. min-max mm <sup>2</sup>
3540000100	35 A	FROM 0,25 TO 2,5

## Flying fuse holder for glass fuses



- For glass fuses size 5x20 our art. 353 00.
- Cable fasteners screw.
- Bayonet lock.

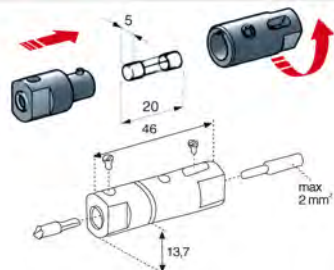

Code	Desc.	Cable sec. min-max mm <sup>2</sup>
3540002100	53057	FROM 0,25 TO 2

## Flying fuse holder for blade fuses



- Fuse holder thermoplastic splash resistant.
- Complete with two pieces of wire section. 1.5 mm<sup>2</sup> 20 cm long.

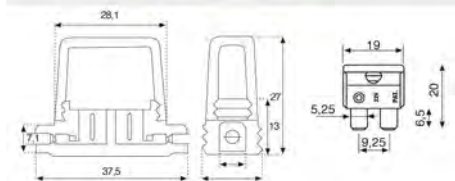

Code	Desc.
3540004100	53077

## Fuse holder with derivation

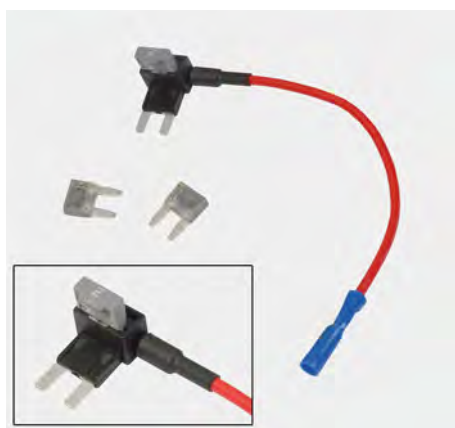

- Holder with derivation.
- To install electrical accessories seamless.
- Quick and easy to install thanks to pluggable terminal to replace the fuse.
- Supplied without fuses.
- Cable length 12 cm.
- Pre-insulated connector cables section 1-2.5 mm<sup>2</sup>.

Code	Desc.	Application
3540004400	53080	Micro fuse blade
3540004410	53090	Blade fuse

## Steering wheel for blade fuse holder microfusibili



- Fuse holder thermoplastic splash resistant.
- Complete with two pieces of wire 1.5 mm<sup>2</sup> 20 cm long.

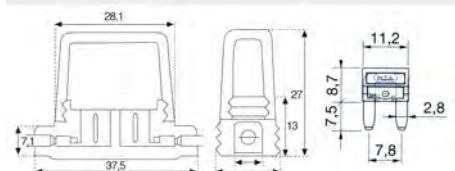

Code	Desc.
3540004000	53076



## 1 way modular fuse holder for blade fuses



- Fuse holder plastic max 16 A.
- You can fit together pieces to get the number of channels desired.

Code	Desc.	Terminal to be used
3540001100	53047	317 00 21260 - 52277

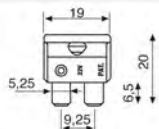

## 1 way modular fuse holder for blade fuses



- Fuse holder in plastic with two couplings for female faston mis. 6.3.
- You can fit together pieces to get the number of channels desired.
- Can be fixed to the wall with our art. 354 00 01300-53049.

Code	Desc.
3540001200	53048

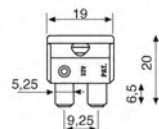

## 1 way modular fuse holder for blade fuses



- Fuse holder in plastic with two couplings for female faston mis. 6.3.
- You can fit together pieces to get the number of channels desired.
- Can be fixed to the wall with our art. 354 00 01300-53049.
- Complete with lid for hs fuse. code 3540001400 - 53050

Code	Desc.	Replacement terminal
3540003100	53067	317 00 22155 - 52454

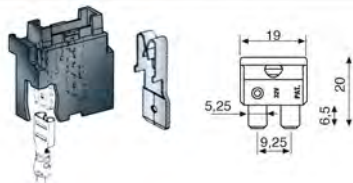

## Cover for protection fuse



- Cover in transparent plastic material for fuse holder art. 354 00 03100-53067.

Code	Desc.
3540001400	53050

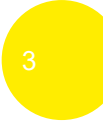
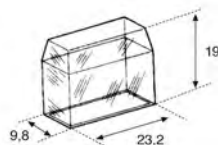

## 1 way modular fuse holder for blade fuses

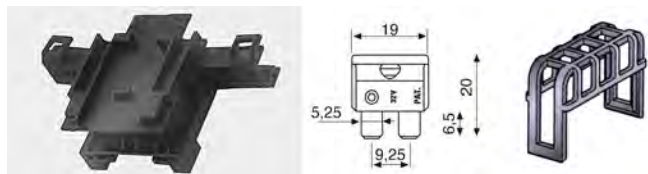

- Fuse holder plastic without terminals.
- You can fit together pieces to get the number of channels desired.
- Can be fixed to the wall with ours. art. 354 00 03300 - 53069.

Code	Desc.	Color	Installable terminal
3540003200	53068NE	BLACK	317 00 22155 - 52446
3540003240	53068GA	-	CAGE PROTECTION

## Fuse holder "in line" for blade fuses



- Fuse terminal for applying online for auto blade fuses.
- Applications for protection of: electrical systems, radio equipment, lighting systems, security systems, ventilation and air conditioning.

Code	Desc.	Cable sec. min-max mm <sup>2</sup>	voltage max V.	Temp. max °C
3540000900	53040	FROM 0,75 TO 2	32	105

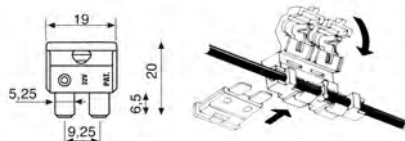

## Modular fuse holder for blade maxi fuses



- Plastic body holder for blade maxi fuses supplied without terminals.
- You can fit together pieces to get the number of channels desired.
- Can be fixed to the wall with our art. 354 00 03300 - 53069

Code	Desc.	Original ref.	Installable terminal
3540001800	53054	FIAT 1/92061/87	3170021715-52366 / 3170021720-52367 / 3170021725-52368 / 3170021845-52392

## Cover for protection fuse



- Cover in transparent plastic material for our fuse holder art. 354 00 01800-53054

Code	Desc.	Original ref.
3540003700	53073	FIAT 1/92058/94

## Fuse holder for tape and midi

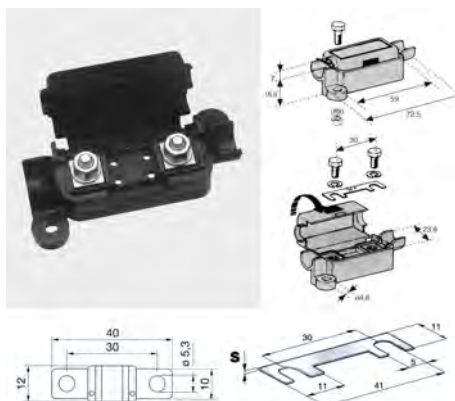

- Fuse holder in plastic material with tightening screw for our fuses tape cod 349 00 with hole spacing of 30 mm and midi cod. 358 02.
- Suitable for circuit protection of glow plugs of diesel cars.
- Supplied without fuse with two brass screws and two washers tin.
- Maximum cable section 6 mm<sup>2</sup>.

Code	Desc.
3540001900	53055

## Fuse holder for Mega fuse



- Mega fuse holder with 2 M8 pins and cover.
- Supplied without fuse

Code	Description
3540004420	Fuse holder for Mega

## Fuse holder for ceramic fuses 80 Volt



- Fuse holder for ceramic fuses with 2 M8 pins and cover.
- Supplied without fuse.

Code	Description
3540004430	Fuse holder for ceramic

## Fuse holder 1 way modular splash-proof for blade fuses



A TENUTA STAGNA

- Fuse holder in plastic material with watertight cover.
- You can fit together pieces to get the number of channels desired.
- Can be fixed to the wall with our art. 354 00 03300 - 53069.
- Terminals installed: our cod. 317 00 22,145 to 52,452.

Code	Desc.	Color secondarylock and corr. max applicable
3540004200	53078	GREEN- 30 A

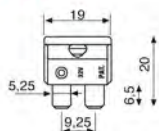

## Fuse holder 1 way modular splash-proof for maxi blade fuses



- Fuse holder in plastic material with watertight cover.
- You can fit together pieces to get the number of channels desired.
- Can be fixed to the wall with our art. 354 00 03300 - 53069.
- Supplied with two terminals our art. 317 00 21,720 to 52,367.
- With the bottom cover can be installed cable sect. max 6 mm<sup>2</sup>, without bottom cover section, you can install cables up to 16 mm<sup>2</sup>.
- Terminals installed: Our art. 317 00 21715-52366 / 317 00 21720-52367 / 317 00 21725 to 52368.

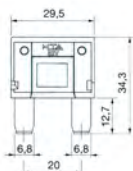

Code	Desc.
3540004300	53079

## Fixing plates to fuse

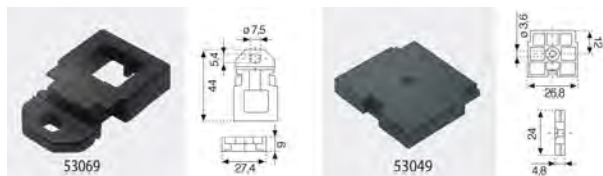

- Platelets in plastic material with screw attachment for the anchorage of our modular fuse holder.

Code	Desc.	For fuse carriers
3540003300	53069	354 00 01800 - 53054   354 00 03200 - 53068   354 00 04200 - 53078   354 00 04300 - 53079
3540001300	53049	354 00 01200 - 53048   354 00 00800 - 530639   354 00 03100 - 53067

## Micro Relays 12 Volt and 24-Volt normally open with resistance- 4 contacts



- It is a remote control switch for continuous service used in motor vehicles, in closing agent of the load circuit.
- It is a micro relay, therefore with reduced size than standard Relays.
- Reduce the maximum voltage.

Code	Description
3170026330	20 amp-12 volt-open
3170026335	30 amp-12 volt- open
3170026340	10 amp-24 volt- open

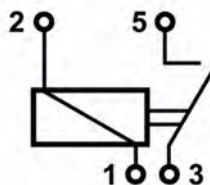



## Micro Relays 12-volt and 24-volt in exchange with resistance- 5 contact



- It is a remote control switch for continuous service used in motor vehicles, in closing agent of the load circuit.
- It is a micro relay, therefore with reduced size than standard Relays.
- Reduce the maximum voltage.

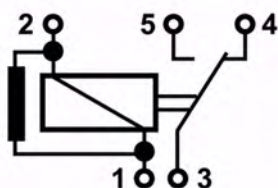

Code	Description
3170026345	10-20 amp-12 volt- in exchange
3170026350	10-20 amp-24 volt- in exchange



## Relays 12 Volt and 24-Volt normally open with resistance- 5 contacts (6,3x0,8)



- It is a remote control switch for continuous service used in motor vehicles, in closing agent of the load circuit.
- It is a micro relay, therefore with reduced size than standard Relays.
- Reduce the maximum voltage.

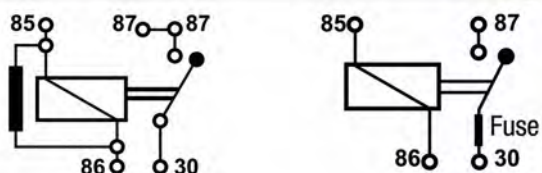

Code	Description	Characteristics
3170026355	40 amp-12 vot-open	With removable bracket
3170026360	30 amp-12 volt- open	With fuse and removable bracket, specifically nautical sector
3170026365	30 amp-24 volt- open	With fixed bracket
3170026370	20 amp-24 volt- open	With fuse and removable bracket, specifically nautical sector

### Relays 12 volts and 24 volts in exchange with resistance- 5 contacts (6.3x0.8)



- It is a remote control switch for continuous service used in motor vehicles, in closing agent of the load circuit.
- It is a micro relay, therefore with reduced size than standard Relays.
- Reduce the maximum voltage.

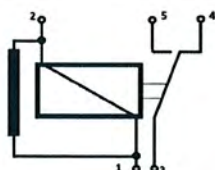

Code	Description	Characteristics
3170026375	20-30 amp-12 volt-in exchange	With removable bracket
3170026380	10-20 amp-24 volt-in exchange	With removable bracket -Rif. IVECO 4718222

### Relays 12-volt and 24-volt power -normally open with resistance- 4 contacts (2x6,3x0,8,2x9,5x1,2)



- It is a remote control switch for continuous service used in motor vehicles, in closing agent of the load circuit.
- It is a micro relay, therefore with reduced size than standard Relays.
- Reduce the maximum voltage.

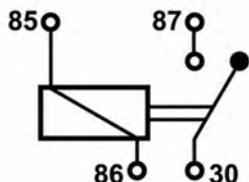

Code	Description	Characteristics
3170026385	70 amp-12 volt-open DP	With removable, special bracket for yachting and industrial vehicles
3170026390	70 amp-24 volt-open DP	Rif. IVECO 4718222

## Brings power relay 4-way

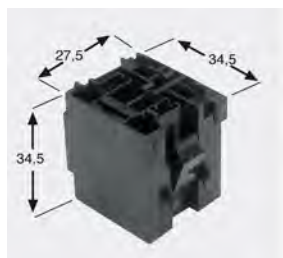

- Wall mountable with our platelets cod. 354 354 00 00 03,300 to 53,069 03,400 to 53,070.
- Terminal to install: N° 2 317 00 21625-52348; 317 00 03810-1422.

Code	Desc.
3170022560	52534

## 5 ways to block micro relay

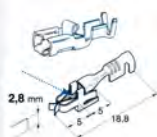
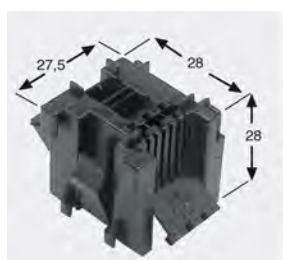

- Terminal to install: N° 2 317 00 21625 to 52348; N° 3 317 00 08050-26178; 317 00 08052-26179.

Code	Desc.
3170022555	52533

## 5 ways to block modular relay standard

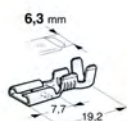

- Wall mountable with the ns. platelets cod. art. 354 00 03300 53069; 354 00 03,400 to 53,070
- Terminal to install: N° 5 317 00 02700- 1404

Code	Desc.
3170021110	52247

## Block for micro relay

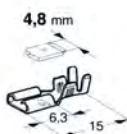
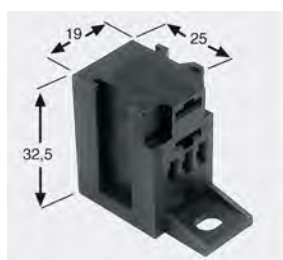

- Block door contact with screw or multiple interlocking.
- Terminal to install: N° 2 317 00 02700-1404; 317 00 02710-1404 / B; 317 00 02720-1405; N° 3 317 00 20,800 to 52,231.

Code	Desc.
3170025380	52638

## Block for intermittent relay

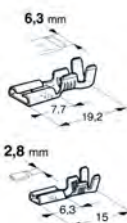

- Block door contact with screw or multiple interlocking.
- Terminal to install: N° 5 317 00 02700-1404; 317 00 02710-1404 / B; 317 00 02720-1405; N° 4 317 00 21125-52250.

Code	Desc.
3170025390	52639

## Block for power relays and control units preheating

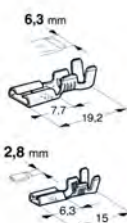
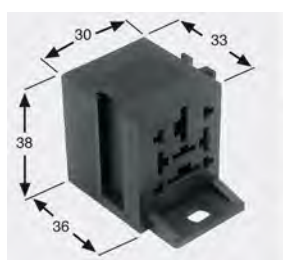

- Block door contact with screw or multiple interlocking.
- Terminal to install: N° 2 317 00 03810-1422 / N ° 3317 00 02700-1404; 317 00 02710-1404 / B; 317 00 02720-1405 / N° 4317 00 21125-52250.

Code	Desc.
3170025400	52640

## Terminal covers Nylon

3

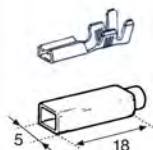

- Resistant to temperature, oil, gasoline etc.
- Satisfying the requirements provided for by the higher specifications.

Code	Desc.	Original ref.	Step
3170002910	1411	FIAT 1/23331/87	2,8

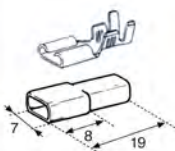

- For female terminals: 317 00 07300-18638

Code	Desc.	Original ref.	Step
3170007310	18639	-	4,7

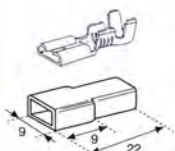

- For female terminals: 317 00 02550-1402.

Code	Desc.	Original ref.	Step
3170004620	1440	-	6,3

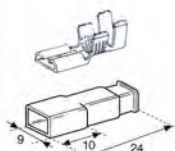

- For female terminals: 317 00 02600-1403 31700 02610-1403 / B.

Code	Desc.	Color	Step
3170000600	1008	BLACK	6,3
3170004400	1430	RED	6,3

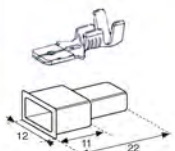

- For male terminals: 317 00 04600-1439 31700 04610-1409 / B

Code	Desc.	Color	Step
3170004500	1431	BLACK	6,3

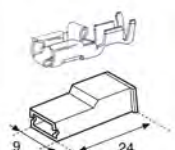

- For female terminals: 317 00 21625-52348

Code	Desc.	Original ref.	Step
3170021660	52355	FIAT 1/23387/87	6,3



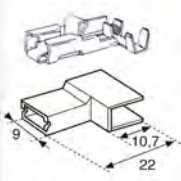

- For female terminals: 317 00 25700-52700.

Code	Desc.	Original ref.	Step
3170005105	1447	FIAT 1/23371/87	6,3

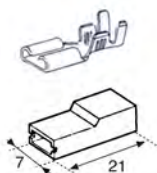

- For female terminals: 317 00 07300-18638

Code	Desc.	Original ref.	Step
3170021640	52351	FIAT 1/23335/80	4,7

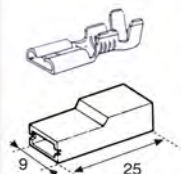

- For female terminals: 317 00 02600-1403 317 00 02610-1403 / B.

Code	Desc.	Original ref.	Step
3170021645	52352	FIAT 1/20558/80	6,3

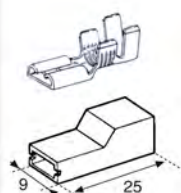

- For female terminals: 317 00 02550-1402

Code	Desc.	Original ref.	Step
3170021650	52353	FIAT 1/20559/80	6,3

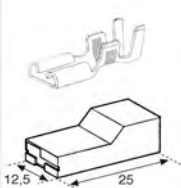

- Resistant to temperature, oil, petrol etc ..
- Satisfying the requirements provided for by the higher specifications.
- For female terminals: 317 00 03900-1423.

Code	Desc.	Original ref.	Step
3170021655	52354	FIAT 1/20557/85	9,5

## Holder blocks females 3-way lamps H4

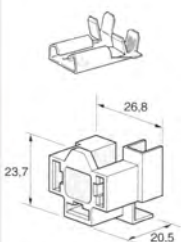

- Block port terminals for lamps with asymmetric attack + H4.
- White color.
- For female terminals: 317 00 21320 to 52289.

Code	Desc.	Original ref.	Step
3170021085	52242	FIAT 1/02579/80	7,7

3

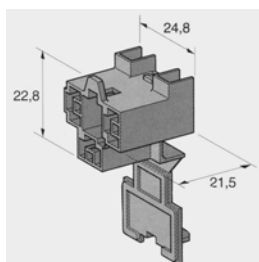

- With inspection door
- Black Colour
- Terminal flag inserted: 317 00 25730-52703 - Step 7.7

Code	Desc.
3170025720	52702

## Female terminal holder 2-way lamps H7

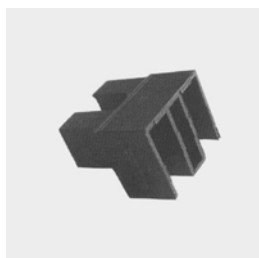

- Terminal fraying inserted: 317 00 25700-52700 - Step 6.3

Code	Desc.
3170025710	52701

## Wired lamp holders connector



- Pre-wired connectors for automotive lamps.

Code	Description	For lamps
3170026400	H4-wired connector	H4



- Pre-wired connectors for automotive lamps.

Code	Description	For lamps
3170026410	H7-wired connector	H7



- Pre-wired connectors for automotive lamps.

Code	Description	For lamps
3170026420	H8-H11 wired connector	H8 and H11



- Pre-wired connectors for automotive lamps.

Code	Description	For lamps
3170026430	HB3-wired connector	HB3

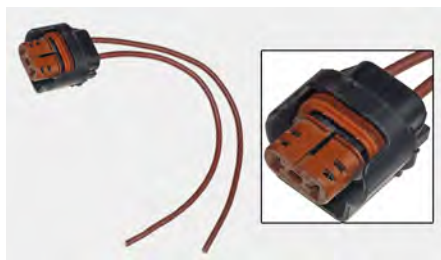

- Pre-wired connectors for automotive lamps.

Code	Description	For lamps
3170026440	HB4-wired connector	HB4



- Pre-wired connectors for automotive lamps.

Code	Description	For lamps
3170026450	TV- all glass wired connector	For all glass

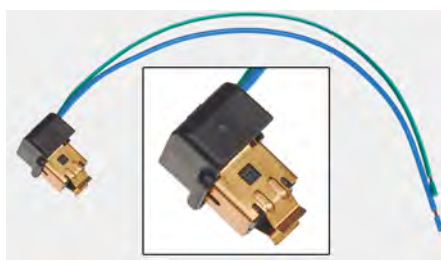

- Pre-wired connectors for automotive lamps.

Code	Description	For lamps
3170026460	H1-wired connector	H1

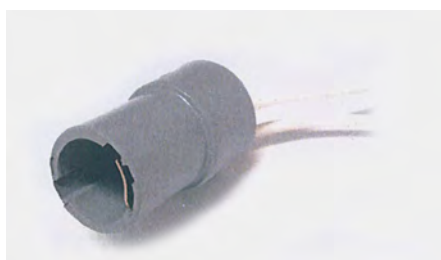

- Pre-wired connectors for automotive lamps.

Code	Description	For lamps
3170026470	H6-wired connector	H6



- Pre-wired connectors for automotive lamps.

Code	Description	For lamps
3170026475	ND- wired connector fog light New Daily	H7

### Connectors for male and female terminals with retaining tooth step 6.3



- Terminals installable on all connectors.
- Male, C / tooth step 6.3.

Code	Desc.	Cable sec. mm <sup>2</sup>	Material
3170002960	1412/1	0.3 - 0.8	RAW BRASS
3170003000	1413	1 - 2.5	RAW BRASS
3170003010	1413/B	1 - 2.5	TINNED BRASS
3170002950	1412	4 - 6	TINNED BRASS

3



- Terminals installable on all connectors.
- Female, C / tooth step 6.3.

Code	Desc.	Cable sec. mm <sup>2</sup>	Material
3170002700	1404	1 - 2.5	RAW BRASS
3170002710	1404/B	1 - 2.5	TINNED BRASS
3170002720	1405	4 - 6	OTTONE STAGNATO

## Connectors for terminals with M. and F. retaining tooth pitch. 6.3



• 1 way male

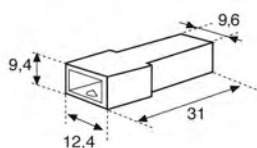

Code	Desc.	Original ref.
3170000700	1015	FIAT 1 20589 80



• 1 way female

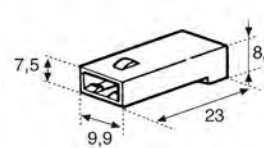

Code	Desc.	Original ref.
3170000800	1016	FIAT 1 20590 80



• 2-way male

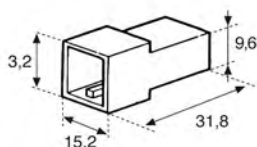

Code	Desc.	Original ref.
3170000900	1017	FIAT 1 20605 80



• 2 way female

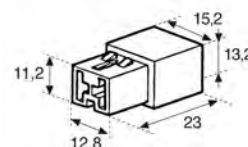

Code	Desc.	Original ref.
3170001000	1018	FIAT 1 20604 80



• 2-way "T" male

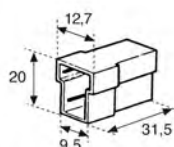

Code	Desc.	Original ref.
3170001100	1019	FIAT 1 20599 80



• 2 way "T" female

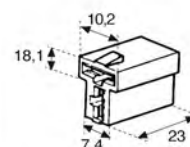

Code	Desc.	Original ref.
3170001200	1020	FIAT 1 20598 80



• 3 way male.

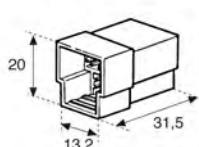

Code	Desc.	Original ref.
3170001300	1021	FIAT 1 20668 80



• 3 way female.

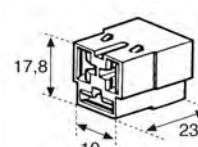

Code	Desc.	Original ref.
3170001400	1022	FIAT 1 20667 80





• 4 way male.

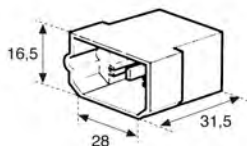

Code	Desc.	Original ref.
3170001500	1023	FIAT 1 20581 80



• 4 way female

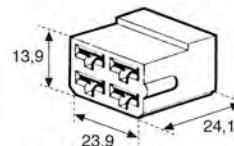

Code	Desc.	Original ref.
3170001600	1024	FIAT 1 20580 80



• 6 way male

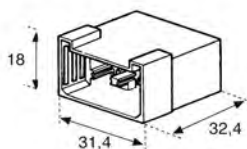

Code	Desc.	Original ref.
3170001700	1025	FIAT 1 02504 80



• 6 way female

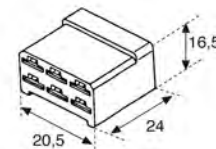

Code	Desc.	Original ref.
3170002400	1033	-



• 6 ways female with wings.

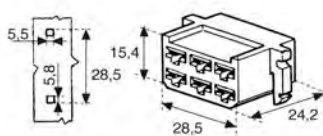

Code	Desc.	Original ref.
3170001800	1026	FIAT 1 02503 80



• 6 way male with wings

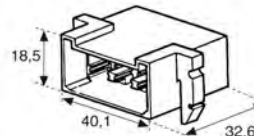

Code	Desc.	Original ref.
3170001900	1027	FIAT 1 20611 80



• 8 way female

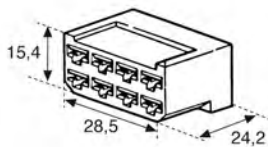

Code	Desc.	Original ref.
3170002000	1028	FIAT 1 20606 80



• 8-way male

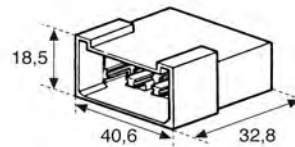

Code	Desc.	Original ref.
3170002100	1029	FIAT 1 20607 80



• 11 way male

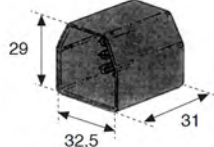

Code	Desc.	Original ref.
3170000630	1012	FIAT 1 20625 87



• 11 way female

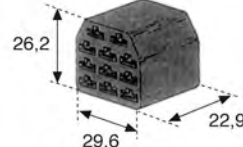

Code	Desc.	Original ref.
3170000650	1013	FIAT 1 20624 87

## Holder block females mixed two-way



- Application: Iveco truck.

Code	Desc.	N° Way
3170025780	52708	2



- Terminals pluggable female

Code	Step
3170003810-1422	9,5
3170002700-1404	6,3

## Holder block male mixed piggyba

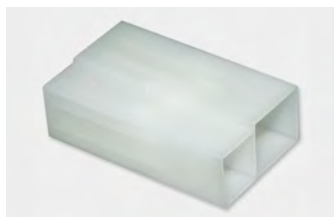

Code	Desc.	N° Way
3170025790	52709	2



Code	Step
3170003000-1413	6,3
3170003820-1422/1	9,5

## Holder blocks females per-pin terminals



Code	Desc.	N° Way
3170025800	52710	1
3170025810	52711	2
3170025820	52712	3
3170025830	52713	4
3170025840	52714	6 3x2
3170025850	52715	9 3x3
3170025860	52716	12 3x4
3170025870	52717	15 3x5



Code	Sez. cable
3170021790-52381	0,5-2,0

- Series Mate-n-lock.
- For various applications.
- 6=3x3 - 12=3x4 - 15=3x5

- Pluggable terminal female

## Blocks series male mate-n-lock-pin terminals



Code	Desc.	N° Way
3170025890	52719	1
3170025900	52720	2
3170025910	52721	3
3170025920	52722	4
3170025930	52723	6 3x2
3170025940	52724	9 3x3
3170025950	52725	12 3x4
3170025960	52726	15 3x5



Code	Sez. cable
3170021785-52380	0,5-2,0

- Series Mate-n-lock.
- For various applications.
- N-way 6 = 3x2 - 9 = 3x3 - 3x4 = 12 - 15 = 3x5

- Selectable terminating male

## Port connectors female Sigma series II



- Application: engine sensors.

Code	Desc.	N° Way
3170026130	52743	2
3170026140	52744	3
3170026150	52745	4



- Female terminal sigma series II

Code	Desc.	Sez. cable
3170022595	52541	0,35-0,75

## Port connectors male "superseal" watertight



Code	Desc.	N° Way
3170021440	52311	1
3170021450	52313	2
3170021465	52316	3
3170021475	52318	4
3170021485	52320	5
3170022420	52506	6



Code	Desc.	Sez. cable
3170022375	52497	1,0-1,5

- Watertight connector "Superseal" with secondary lock terminals step 1.5.
- Applications: sensors engine compartment.

- Male terminal step 1.5 insertable

## Plug for unused holes for plugs and sockets



Code	Desc.	Material
3170022410	52504	SILICON

## Sealing ring for male and female terminals



Code	Desc.	Material
3170021415	52306	SILICON

3

## Sealing ring for male and female terminals



Code	Description
3170021417	Gommino giallo per filo d.est 1,8-2,4

## Port connectors females "superseal" watertight



Code	Desc.	N° Way
3170021435	52310	1
3170021445	52312	2
3170021455	52314	3
3170021470	52317	4
3170021480	52319	5
3170022415	52505	6



Code	Desc.	Sez. cable
3170022370	52496	1,0-1,5

- Watertight connector "Superseal" with secondary lock terminals step 1.5.
- 2-way female.

- Female terminal step 1.5 insertable

## Port connectors male "series 280" watertight



- Applications: engine compartment.
- 2-way male.



- Terminal male "series 280" insertable

Code	Desc.	N° Way
3170021495	52322	1
3170021505	52324	2
3170021515	52326	3

Code	Desc.	Sez. cable
3170021425	52308	1,0-2,5

## Sealing ring for male and female terminals



Code	Desc.	Material
3170021430	52309	SILICON



## Port connectors female "series 280" watertight



- 2 way female.

Code	Desc.	N° Way
3170021490	52321	1
3170021500	52323	2
3170021510	52325	3



Code	Desc.	Sez. cable
3170021420	52307	2 - 3

## Port connector male "econoseal" watertight



- Connectors for Iveco.
- Applications: sensors.

Code	Desc.	N° Way
3170015795	52121	2



- Terminal male "econoseal" insertable

Code	Sez. cable
3170021795-52382	0,5-1,5

## Port connector females "econoseal" watertight



- Connector for Iveco.

Code	Desc.	N° Way
3170015796	52122	2



- Female terminal "econoseal" insertable

Code	Sez. cable
3170021800-52383	0,5-1,5

## Hood 2-way



Code	Description	N° Way
3170022035	52430-2 way headset x connect.	2
3170022060	52435-3 way headset x connect.	3
3170022430	52508-4 way headset x connect.	4
3170022435	52509-5 way headset x connect.	5
3170022070	52437-7 way headset x connect.	7

## Port connectors female junior timer



Code	Desc.	N° Way
3170022310	52484	2
3170022330	52488	3
3170022335	52489	4
3170022340	52490	5
3170022345	52491	6
3170022350	52492	7



Code	Desc.	Sez. cable
3170022300	52482	0,5-1,5

- Applications: electronic fuel injection, to sensors and injectors.

- Terminale femmina "junior timer" inseribili

## Port Connector male "power timer"



Code	Desc.	N° Way
3170022355	52493	2



Code	Desc.	Sez. cable
3170022360	52494	0,5-1,0

- Terminal male "power timer" insertable

## Port Connector male "junior power timer"

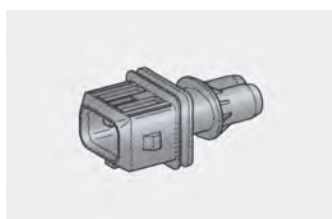

Code	Desc.	N° Way
3170025770	52707	2

- Application: for sensors and injectors.



Code	Desc.	Sez. cable
3170025740	52704	0,5-1,0

- Male terminal inserted jpt

## Seal rubber for terminals jpt



Code	Desc.	Color
3170025760	52706	HEAVENLY

## Circular Connectors DIN 1.5 for lights VI



- Circular Connectors DIN 1,5 -7 WAYS
- In the kit, consisting of 1 circular connector, 7 rubbers, 7 terminals and 1 corrazza straight + 90 °
- Mounted on Stralis

Code	Description	Content
3170026480	Kit conn.circ. DIN 1,5	1 circular connector 1 corrazza straight +90° 7 terminals 7 rubbers

Spare Parts	
Accessories	Code
Female terminal sez.0,8-1,5 mm2	3170026482
Red rubber 2.8-3.3	3170021415

## Circular connectors SICMA FCI for lights Iveco Daily 8-Way



- Circular Connectors SICMA FCI 8 WAYS
- To Iveco Daily 6-front lights
- In the kit, consisting of 1 circular connector, 6 gray rubbers for Sicma 1.5 mm and 2 blue rubbers for Sicma 2.8, 6 female terminals Sicma 1.5 sez.0,35-0,75 mm and 2 terminals female Sicma 2.8 sez.0,35-0,75 mm.

Code	Description	Content
3170026485	Kit conn. Sicma FCI 8 ways	1 Connector 8 terminals 6+2 8 rubbers 6+2

Spare Parts	
Accessories	Code
Grey rubber for Sicma 1,5 mm	3170026487
Blue rubber for Sicma 2,8 mm	3170022305
Female terminal Sicma 1,5 sez. 0,35-0,75 mm2	3170022595
Female terminal Sicma 2,8 sez. 0,35-0,75 mm2	3170026490

## Circular connectors for lights VI-3 Ways



- Circular Connectors 3 way
- To Iveco Eurocargo license plate lights
- In the kit, consisting of 1 circular connector, 3 red rubbers 2.8-3.3 mm, 3 female terminals sez.1-2,5 mm.

Code	Description	Content
3170026495	Kit conn. circ.3 ways	1 circular connector 3 terminals 3 rubbers

Spare Parts	
Accessories	Code
Female terminal sez.1-2,5 mm	3170026500
Red rubber 2.8-3.3	3170021415

## Circular connectors for lights VI-10 Ways

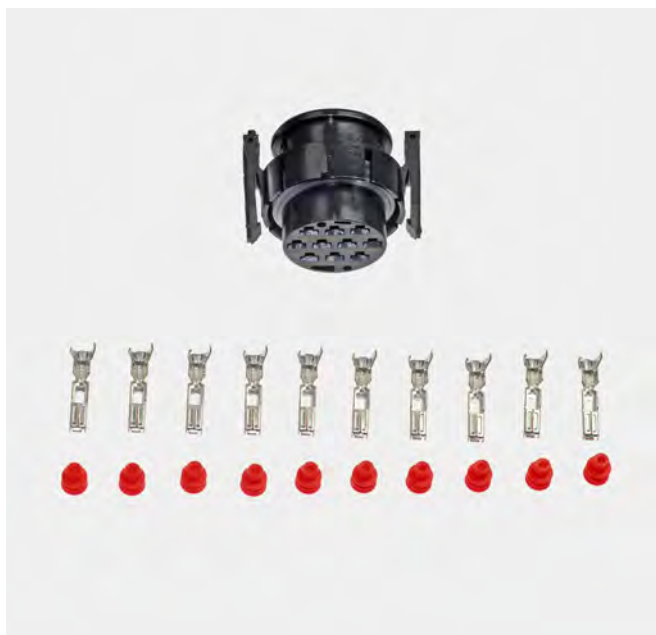

- Circular Connectors 10 way
- To Iveco Eurocargo rear lights
- In the kit, consisting of 1 circular connector, 10 red rubbers 2.8-3.3 mm, 10 female terminals sez.1-2,5 mm.

3

Code	Description	Content
3170026505	Kit conn .10 ways for headlights	1 circular connector 10 terminals 10 rubbers

Spare Parts	
Accessories	Code
Female terminal sez.1-2,5 mm	3170026500
Red rubber 2.8-3.3	3170021415

## MCP connectors for fitters 7 poles from 1.5 to 2.8



- Connectors 7-pole female port
- In the kit, consisting of 1 connector, 4 blue rubbers 1,2-2.1, 3 yellow rubbers MQS 1.10-1,30, 4 MCP female terminals sez.0,8-1,5 1.5 mm, 3 MCP female terminals sez.1-2,5 2.8 mm, 1 corrazza 90°
- Mercedes Euro 6 rear-Volvo-Daf-Scania.

Code	Description	Content
3170026510	Kit conn. MCP 7 poles	1 connector 7 female terminals 4+3 7 rubbers 4+3 1 corrazza 90°

Spare Parts	
Accessories	Code
Blue rubber 1,2-2.1	3170025760
Yellow rubber MQS 1.10-1,30	3170026512
Female terminal MCP 1,5 sez.0,8-1,5 mm2	3170026514
Female terminal MCP 2,8 sez.1-2,5 mm2	3170026516



## MCP connectors 1.5 for fitters 8 poles



- Connectors 8 poles female port Series MCP 1.5
- In the kit, consisting of 1 connector, 8 MQS yellow rubbers 1:10 to 1:30, 8 MCP 1.5 female terminals sez. 0,8-1,5 mm, 1 corrazza 90°
- Mercedes-Volvo-Daf-Scania.

3

Code	Description	Content
3170026520	Kit conn. MCP 1,5 8 poles	1 connector 8 terminals 8 rubbers 1 corrazza 90°

Spare Parts	
Accessories	Code
Yellow rubber MQS 1.10-1,30	3170026512
Female terminal MCP 1,5 sez.0,8-1,5 mm2	3170026514

## Rubber rear pipe with plastic ring for cargo. Mod.1



- Pipette rubber seal.
- Threaded ring for maximum grip on the lantern.
- Complete with steel washer inner sealing.
- **Adaptable to our codes: 428 00 00200 – 428 00 00190.**
- Shares and dimensions in the drawing.

Code	Description
4280002100	250-PIPA MODELLO 1

## Rubber rear pipe with plastic ring for cargo. Mod.2

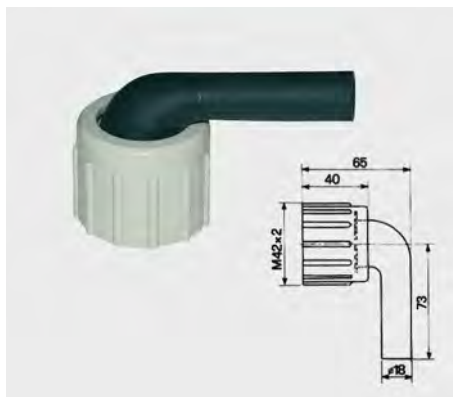

- Pipette rubber seal.
- Threaded ring for maximum grip on the lantern.
- Complete with steel washer inner sealing.
- **Adaptable to our codes: 428 00 00130 to 428 00 00140.**
- Shares and dimensions in the drawing.

Code	Description
4280002150	260-PIPAE MODEL 2

## Rubber rear pipe with plastic ring for cargo. Mod.3



- Pipette rubber seal.
- Threaded ring for maximum grip on the lantern.
- Complete with steel washer inner sealing.
- **Adaptable to our codes: 428 00 00150.**
- Shares and dimensions in the drawing.

Code	Description
4280002200	270-PIPA MODELLO 3

## Rubber rear pipe with plastic ring for cargo. Mod.4



- Pipette rubber seal.
- Threaded ring for maximum grip on the lantern.
- Complete with steel washer inner sealing.
- **Adaptable to our codes: 428 00 00230 – 428 00 00240.**
- Shares and dimensions in the drawing.

Code	Description
4280002250	280-PIPA MODELLO 4

## Rubber rear pipe with plastic ring for cargo. Mod.5



- Pipette rubber seal.
- Threaded ring for maximum grip on the lantern.
- Complete with steel washer inner sealing.
- **Adaptable to our codes: 428 00 00460 – 428 00 00470.**
- Shares and dimensions in the drawing.

Code	Description
4280002300	290-PIPA MODELLO 5

## Connectors for various applications not sealed FIAT Group



- For resistance FIAT group.

Code	Description	Content
3170026525	Kit conn. Fiat resistance	1 connector 5 terminals

Spare Parts		
Article	Code	Description
Spare terminal	3170022520	52526- fem. term. 1-2,5 mm2

## Connectors for various applications not sealed FIAT Group



- For resistance heating FIAT Group.

Code	Description	Content
3170026530	Kit conn. res. heat. Fiat group	1 connector 5 terminals

Spare Parts		
Article	Code	Description
Spare terminal	3170026490	Female terminal Sicma 2,8 sez. 0,35-0,75 mm2

## Connectors resistance Grande Punto-Bravo



- For resistance FIAT Group latest cars.

Code	Description	Content
3170026532	Kit conn. res .heat. Fiat group Punto/Bravo	2 connectors grey+black 4 terminals

Spare Parts		
Article	Code	Description
Spare terminal	3170026492	Female terminal Sicma 4,8 sez. Standard time

## Connectors for control unit new Fiat Panda



- For control unit new Fiat Panda

Code	Description	Content
3170026535	Kit control unit new Panda	1 connector 10 terminals

Spare Parts		
Article	Code	Description
Spare terminal	3170026490	Female terminal Sicma 2,8 sez.
Spare terminal	3170022595	52541-fem. term. 1-1,5 mm2

## Connectors for Japanese cars alternators



- For Japanese cars alternators.

Code	Description	Content
3170026540	Kit conn. Japanese cars	1 connector 3 terminals 3 rubbers

Spare Parts	
Code	Description
3170025760	Blue rubbers 1,2-2.1
3170026542	Female terminal x 3170026540

## Connector Bosch MBK 2 ways



- Connector kit, composed of connector rubbers and terminals.
- For injection and common-rail

Code	Description	Content
3170026545	Kit conn. Bosch MBK 2 ways	1 connector 2 terminals 2 rubbers

Spare Parts	
Code	Description
3170025760	Blue rubbers 1,2-2.1
3170026547	Terminal MBK sez. 0,5-1 mm <sup>2</sup>

## Connector Bosch MBK 3 Ways

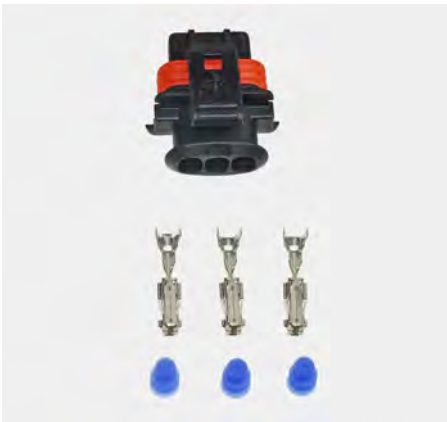

- Connector kit, composed of connector rubbers and terminals.
- For injection and common-rail.

Code	Description	Content
3170026550	A-Kit conn .Bosch MBK 3 ways	1 connector 3 terminals 3 rubbers

Spare Parts	
Code	Description
3170025760	Blue rubbers 1,2-2.1
3170026547	Terminals MBK sez. 0,5-1 mm <sup>2</sup>

## Connector Bosch MBK 3 Ways



- Connector kit, composed of connector rubbers and terminals.
- For injection and common-rail.

Code	Description	Content
3170026555	B-Kit conn. Bosch MBK 3 ways	1 connector 3 terminals 3 rubbers

Spare Parts	
Code	Description
3170025760	Blue rubbers 1,2-2.1
3170026547	Terminal MBK sez. 0,5-1 mm <sup>2</sup>

## Connector Bosch JPT 2 Ways



- Connector kit, composed of connector rubbers and terminals.
- For injection and common-rail

Code	Description	Content
3170026560	Kit conn. Bosch JPT 2 ways	1 connecteur 2 cosses 2 caoutchouc

Spare Parts	
Code	Description
3170025760	Blue rubbers 1,2-2.1
3170022300	Terminal JPT sez.0,5-1 mm <sup>2</sup>

## Connector Bosch JPT 3 Ways



- Connector kit, composed of connector rubbers and terminals.
- For injection and common-rail.

Code	Description	Content
3170026565	Kit conn. Bosch JPT 3 ways	1 connector 3 terminals 3 rubbers

Spare Parts	
Code	Description
3170025760	Blue rubbers 1,2-2.1
3170022300	Terminal JPT sez.0,5-1 mm <sup>2</sup>

## Connector Bosch JPT 4 Ways



- Connector kit, composed of connector rubbers and terminals.
- For injection and common-rail

Code	Description	Content
3170026570	Kit conn. Bosch JPT 4 ways	1 connector 4 terminals 4 rubbers

Spare Parts	
Code	Description
3170025760	Blue rubbers 1,2-2.1
3170022300	Terminal JPT sez.0,5-1 mm <sup>2</sup>

## Connectors for Injection Ford and Opel group 2 Ways



- Kit sealed connector for Ford and Opel group
- For injection and common-rail

Code	Description	Content
3170026575	Kit conn. Ford-Opel injection 2 ways	1 connector 2 terminals 2 rubbers

Spare Parts	
Code	Description
3170026512	Yellow rubbers MQS 1.10-1,30
3170022275	Female terminal Micro timer sez.0,5-1 mm <sup>2</sup>

## Connectors for injection BMW-Mercedes and group VW Audi Seat Skoda Porsche 3 Ways



- Kit sealed connector for BMW and Mercedes group
- For injection and common-rail

Code	Description	Content
3170026580	Kit conn. injection VW group	1 connector 3 terminals 3 rubbers

Spare Parts	
Code	Description
3170025760	Blue rubbers 1,2-2.1
3170026582	Female terminal Micro timer sez.0,5-1 mm <sup>2</sup>



## Connectors for injection common-rail Nissan 3 Ways



- Kit sealed connector for Nissan group
- Common-rail system and injection.

Code	Description	Content
3170026585	1/Kit conn. Common -rail Nissan 3 ways	1 connector 3 terminals 3 rubbers

Spare Parts	
Code	Description
3170026487	Grey rubber for Sicma 1,5 mm
3170026587	Female terminal Econoseal J sez.0,3-0,8 mm2

## Connectors for injection common-rail Nissan 3 Ways



- Kit sealed connector for Nissan group
- Common-rail system and injection.

Code	Description	Content
3170026590	2/Kit con. Common-rail Nissan 3 ways	1 connector 3 terminals 3 rubbers

Spare Parts	
Code	Description
3170026487	Grey rubber for Sicma 1,5 mm
3170026592	Male terminal Econoseal J sez.0,3-0,8 mm

## Connectors for injection common-rail Renault-Peugeot-Citroen-Ford-Opel group 3 Ways



- Kit sealed connector for various automotive groups
- Common-rail system and injection.

Code	Description	Content
3170026595	Kit conn. Common-rail Renault-Opel-Ford-Peugeot-Citroen	1 connector 3 terminals

Spare Parts	
Code	Description
3170022595	Female terminal Sicma 1,5 sez.0,35-0,75 mm

## Pluggable terminal blocks for female series 0.40



- Application for car interiors.

Code	Desc.	Sez. cable
3170025980	52728	0,2-0,5

3

## Selectable terminating female MQS

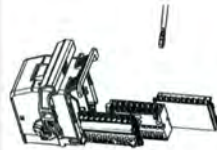

- Application for car interiors.
- For nodes door: Y, Ideas, Stilo and latest Fiat.

Code	Desc.	Sez. cable
3170026000	52730	0,2-0,5

## Selectable terminating male MQS



Code	Desc.	Sez. cable
3170026010	52731	0,75-1,5

## Female terminal series 187



- Applications: Control and deflected guide.

Code	Desc.	Sez. cable
3170022500	52522	1,0-1,5

## Female end series 0.70 II generation



- Application for car interiors.

Code	Desc.	Sez. cable
3170026020	52732	0,75-1,5

## Male end series 0.70 II generation



Code	Desc.	Sez. cable
3170026030	52733	0,75-1,5

## Female terminal inserted: series jpt 2.8 without rubber



Code	Desc.	Sez. cable
3170008050	26178	0,5-1,0
3170008052	26179	1,0-2,5

## Terminal connectors 12-way SPT



- Applications: Iveco Stralis.

Code	Desc.	Sez. cable
3170026060	52736	1,0-2,5

### Female cylindrical terminal D. 1.6 series CPC



- Diagnostic application

Code	Desc.	Sez. cable
3170026070	52737	0,75-1,5

### Male cylindrical terminal D. 1.6 series CPC



Code	Desc.	Sez. cable
3170026080	52738	0,75-1,5

### Female terminal for waterproof connectors series Econoseal / Timer



- Female terminal for VW, Renault step 1.5

Code	Description	Sez. cable
3170022470	52516 signal	1,0-1,5
3170026090	52739 power	1,0-2,5

### Male terminal for waterproof connectors series Econoseal / Timer



Code	Description	Sez. cable
3170022460	52514 signal	1,0-1,5
3170026100	52740 power	1,0-2,5

### Terminale femmina serie 150



- Application: engine compartment.

Code	Desc.	Sez. cable
3170026110	52741	0,5-1,0

### Male end 150 series



Code	Desc.	Sez. cable
3170026120	52742	0,5-1,0

### Terminal female connectors for front and rear doors Fiat group



- Auxiliary terminal step 1.5.
- Power terminal step 2.8.

Code	Description	Sez. cable
3170022595	52541 auxiliary	0,35-0,75
3170022605	52543 power	1,0-2,5

### Male terminal connectors for front doors. and post. Fiat group

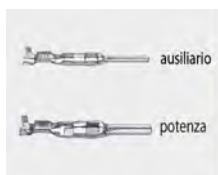

- Auxiliary terminal step 1.5.
- Power terminal step 2.8.

Code	Description	Sez. cable
3170022600	52542 Auxiliary	0,35-0,75
3170022610	52544 Power	1,0-2,5

3

### Seal for signal connectors series C280



- For sensors, controllers, injectors
- Applications: cars Fiat group

Code	Desc.	Material
3170021415	52306	SILICON

### Terminal for blocks power timer



- For conditioners.

Code	Desc.	Sez. cable
3170021840	52391	1,0-1,5

### Holder blocks 630 series female ponds Metripack



- Applications: Radiator Fan.

Code	Desc.	N° Way
3170022425	52507/2	2
3170022426	52507/3	3

### Female terminal series 630 - step 6.3



Code	Desc.	Sez. cable
3170022440	52510	2,5-4,0

### Sealing ring for series 630 terminals



Code	Desc.	Material
3170022445	52511	SILICON

### Holder blocks 630 series male ponds Metripack



- Application: cutting the engine compartment.

Code	Desc.	N° Way
3170022545	52531	2
3170022546	52531/3	3

### Male end 630 series insertable - step 6.3



Code	Desc.	Sez. cable
3170022550	52532	2,5-4,0

## Female terminals for blocks series Yasaki



- Application: engine compartment Fiat cars and Japanese.
- Power terminal step 2.8.

Code	Description	Sez. cable
3170022520	52526 power	1,0-2,5

## Male terminals for blocks series Yasaki



- Power terminal step 2.8.
- Signal terminal step 1.5.

Code	Description	Sez. cable
3170022530	52528 signal	0,3-0,5

## Spade connectors plug laminated 2.8 mm pitch

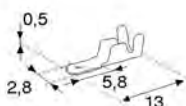

Code	Desc.	Sez. cable
3170021820	52387	0,5-1,0

## Connettori faston a innesto lamellare passo 2.8 mm

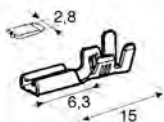

- With retaining tooth.

Code	Desc.	Sez. cable
3170002900	1410	0,5-1,0

## Terminal male plug lamellar step 2.8



- Car radio DIN 46343
- With retaining tooth

Code	Desc.	Sez. cable
3170018400	05628	0,5-1,0

## Female termination plug lamellar step 2.8

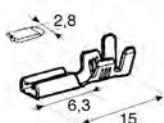

- With retaining tooth.

Code	Desc.	Sez. cable
3170021125	52250	0,5-1,0

## Female termination plug lamellar step 4.7

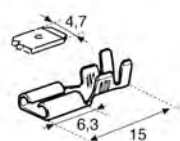

- With retaining tooth.

Code	Desc.	Sez. cable
3170020800	52231	0,5-1,0



### Terminal male plug lamellar step 5

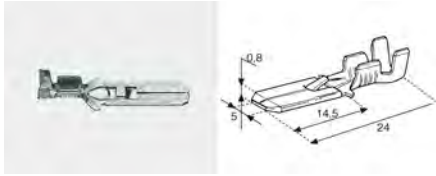

- With retaining tooth.
- Blocks for Labinal.

Code	Desc.	Sez. cable
3170021520	52327	0,5-1,5

### Female termination plug lamellar step 5

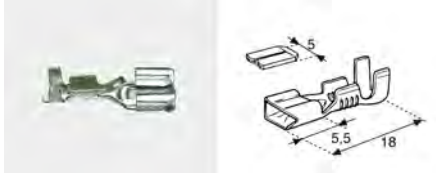

- With retaining tooth
- Blocks for Labinal.

Code	Desc.	Sez. cable
3170021555	52334	0,5-1,5

### Terminal male plug lamellar step 6.3

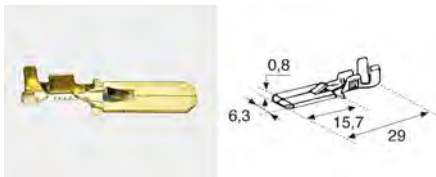

- With retaining tooth.

Code	Desc.	Sez. cable
3170003000	1413	1,0-2,5
3170002950	1412	4,0-6,0

### Female termination plug lamellar step 6.3

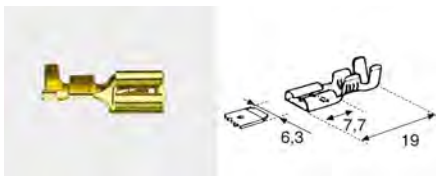

- With retaining tooth.

Code	Desc.	Sez. cable
3170002720	1405	2,5-6,0
3170002700	1404	1,0-2,5

### Terminal male plug lamellar step 6.3

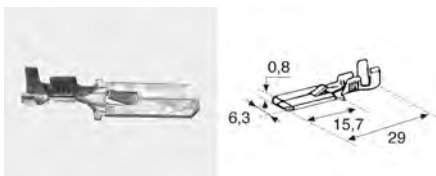

- With retaining tooth

Code	Desc.	Sez. cable
3170003010	1413/B	1,0-2,5

### Terminale femmina ad innesto lamellare passo 6.3

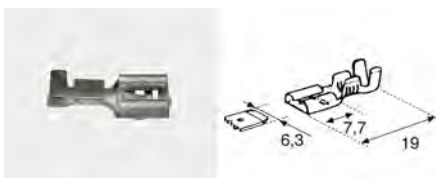

- Con dentino di ritegno

Code	Desc.	Sez. cable
3170002710	1404/B	1,0-2,5

### Female termination plug lamellar step 9.5



- With retaining tooth

Code	Desc.	Sez. cable
3170003810	1422	4,0-6,0

### Selectable terminating male



- With retaining tooth

Code	Desc.	Step
3170003820	1422/1	9,5

### ΦΙΣΑΚΙ ΑΡΣΕΝΙΚΟ 4.7

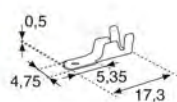

- ΧΩΡΙΣ ΑΚΙΔΑ

Code	Desc.	Sez. cable
3170021610	52345	0,5-1,0

### ΦΙΣΑΚΙ ΘΗΛΥΚΟ 4.7

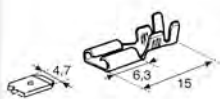

- ΧΩΡΙΣ ΑΚΙΔΑ

Code	Desc.	Sez. cable
3170007300	18638	0,5-1,0

### ΦΙΣΑΚΙ ΑΡΣΕΝΙΚΟ 6.3

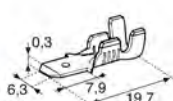

- ΧΩΡΙΣ ΑΚΙΔΑ

Code	Desc.	Sez. cable
3170004600	1439	1,5-2,5

### ΦΙΣΑΚΙ ΘΗΛΥΚΟ 6.3



- ΧΩΡΙΣ ΑΚΙΔΑ

Code	Desc.	Sez. cable
3170002800	1405	2,8-8,8
3170002880	1402	2,8-8,8

### ΦΙΣΑΚΙ ΑΡΣΕΝΙΚΟ ΑΣΗΜΙ 6.3

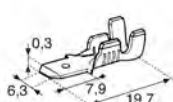

- ΧΩΡΙΣ ΑΚΙΔΑ

Code	Desc.	Sez. cable
3170004610	1439/B	1,5-2,5

### ΦΙΣΑΚΙ ΘΗΛΥΚΟ ΑΣΗΜΙ 6.3

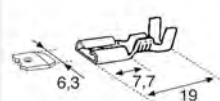

- ΧΩΡΙΣ ΑΚΙΔΑ

Code	Desc.	Sez. cable
3170002610	1403/B	1,0-2,5

### ΦΙΣΑΚΙ ΘΗΛΥΚΟ 6.3



- ΜΕ ΑΚΙΔΑ

Code	Desc.	Sez. cable
3170002720	1405	2,5-6,0
3170002700	1404	1,0-2,5

### ΦΙΣΑΚΙ ΑΡΣΕΝΙΚΟ 6.3

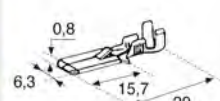

- ΜΕ ΑΚΙΔΑ

Code	Desc.	Sez. cable
3170003000	1413	1,0-2,5
3170002950	1412	4,0-6,0

3

### Terminale femmina + innesto maschio passo 6.3

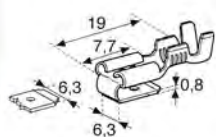

- Without retaining tooth.

Code	Desc.	Sez. cable
3170016000	05143	0,8-2,5

### Female termination plug lamellar step 9.5

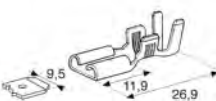

- Without retaining tooth

Code	Desc.	Sez. cable
3170003900	1423	2,0-4,0

### Terminal male plug lamellar step 9.5



- With retaining tooth.

Code	Desc.	Sez. cable
3170003820	1422/1	4-6

### Female terminal step 6.3 for fuse and portarelais

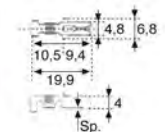

Code	Desc.	Sez. cable
3170022145	52452	0,5-1,5

### Female fuse terminal for our 354 00 01100 6.3 step



Code	Desc.	Sez. cable
3170021260	52277	0,5-1,5

### Female terminal with lamellar graft male step 6.3

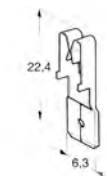

Code	Desc.
3170022155	52454

### Terminal male power step 9.5



Code	Desc.	Sez. cable
3170025510	52651	6,0-8,0
3170021855	52394	10-16

### Terminale femmina di potenza passo 9.5

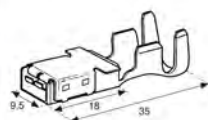

Code	Desc.	Sez. cable
3170021715	52366	1,0-2,5
3170021720	52367	4,0-6,0
3170021725	52368	6,0-10,0
3170021845	52392	16,00

### Terminal male plug connector econoseal d. 1.5



Code	Desc.	Sez. cable
3170021795	52382	0,5-2,5

### Female terminal plug connection econoseal d. 1.5



Code	Desc.	Sez. cable
3170021800	52383	0,5-2,5

### Terminal male plug connector d. 1.6



Code	Desc.	Sez. cable
3170015600	45522	1,5-2,5

### Female terminal plug connection d. 1.6



Code	Desc.	Sez. cable
3170015700	45706	1,5-2,5

### Terminal male plug connector mate-n-lock D.2



Code	Desc.	Sez. cable
3170021785	52380	0,5-2,5

### Female terminal plug connection mate-n-lock D.2



Code	Desc.	Sez. cable
3170021790	52381	0,5-2,5

### Terminal male plug connector d. 2.1



- Water temperature bmw

Code	Desc.	Sez. cable
3170021295	52284	1,0-2,5

### Terminal male plug connector series DIA D.2.5



- To switch ignition.

Code	Desc.	Sez. cable
3170022400	52502	1,0-2,5

### Female terminal plug connection d. 2.5



Code	Desc.	Sez. cable
3170022405	52503	1,0-2,5

### Terminal male plug connector d.4

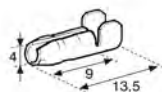

Code	Desc.	Sez. cable
3170003800	1421	1,0-2,5

### Female terminal plug connection d.4

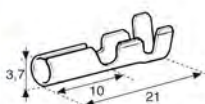

Code	Desc.	Sez. cable
3170003600	1419	1,0-2,5

### Terminal male plug connector d. 4



Code	Desc.	Sez. cable
3170015800	05038	1,0-2,5

### Female terminal plug connection d. 4



Code	Desc.	Sez. cable
3170015820	05051	1,0-2,5

### Female terminal series mark II step 2.8

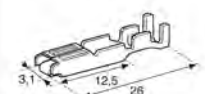

- For taillights.

Code	Desc.	Sez. cable
3170021830	52389	0,5-1,5

### Male terminal series mark II step 2.8

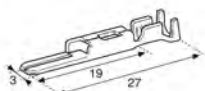

Code	Desc.	Sez. cable
3170021835	52390	0,5-1,5

### Female terminal series PT step 6.3



Code	Desc.	Sez. cable
3170021840	52391	2,5-4,0



## Terminale femmina c/molla inox JPT passo 2.8



Code	Desc.	Sez. cable
3170008050	26178	0,5-1,0
3170008052	26179	1,5-2,5

## Terminal dashboards and taillights Fiat Punto, Bravo, Brava



Code	Desc.	Sez. cable
3170025420	52642	0,5-1,0

## Terminal flag for dashboards and light post. Fiat Punto, Bravo, Brava



Code	Desc.	Sez. cable
3170025430	52643	0,5-1,0

## Terminal flag for lamp asymmetric + H4

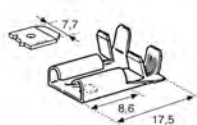

Code	Desc.	Sez. cable	Step
3170021320	52289	1,0-2,5	7,7

## Terminal flag for lamp H4

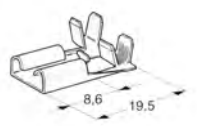

Code	Desc.	Sez. cable	Step
3170025730	52703	1,0-2,5	7,7

## Terminal fraying flag for lamp H7

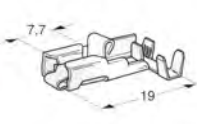

Code	Desc.	Sez. cable	Step
3170025700	52700	1,0-2,5	6,3

## Female end series 0.70 mini mic for Fiat step 1.5

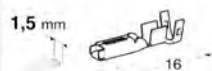

Code	Desc.	Sez. cable
3170022265	52475	0,5-1,5

## Male end series 0.70 mini mic for Fiat step 1.5

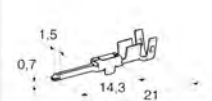

Code	Desc.	Sez. cable
3170022260	52474	0,5-1,5

### Female terminal for central locking BMW, Porsche



Code	Desc.	Sez. cable
3170022275	52477	0,2-0,5

3

### Terminale femmina per gruppo VW, Renault passo 1.5

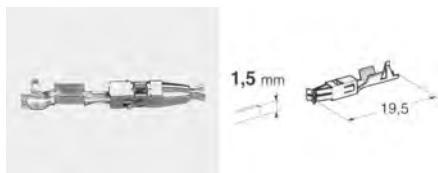

Code	Desc.	Sez. cable
3170025450	52645	0,5-1,0

### Terminal male for VW, Renault step 1.5

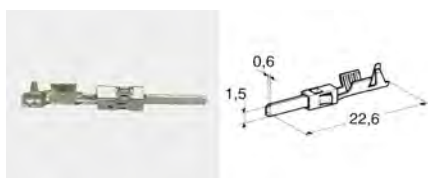

Code	Desc.	Sez. cable
3170025440	52644	0,5-1,0

### Terminal male connectors for 29-way front door step 1.5



Code	Desc.	Sez. cable
3170022460	52514	1,0-1,5

### Terminal female connectors for 10-way front door step 1.5



Code	Desc.	Sez. cable
3170022470	52516	1,0-1,5

### Terminal male connectors for 10-way front door step 1.5



Code	Desc.	Sez. cable
3170022465	52515	1,0-1,5

### Terminal male power connector series 187 step 4.8



Code	Desc.	Sez. cable
3170022485	52519	1,5-2,5

### Terminale femmina di segnale per connettori serie 187 passo 1.5



Code	Desc.	Sez. cable
3170022500	52522	1,0-1,5

### Eyebolt terminal brass

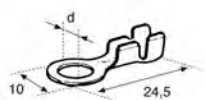

- Thickness 0.6mm

Code	Desc.	Sez. cable	Internal D.
3170021875	52398	1,0-2,0	4,3
3170021880	52399	1,0-2,0	5,4
3170021885	52400	1,0-2,0	6,25

### Eyebolt terminal brass

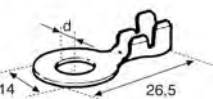

- Thickness 0.8mm

Code	Desc.	Sez. cable	Internal D.
3170021895	52402	2,0-4,0	5,3
3170021900	52403	2,0-2,5	6,4
3170021905	52404	2,0-4,0	8,4

### Terminale ad occhiello in ottone



- Spessore 0,6 mm

Code	Desc.	Sez. cable	D1 mm.	D2 mm	L1 mm
3170016700	05205	0,5-1,0	5,3	9,5	17,5
3170016800	05207	0,5-1,0	6,5	12	22,0
3170016900	05209	0,5-1,0	8,4	14	21,0
3170017200	05215	1,0-2,5	4,3	8,0	18,3
3170017300	05217	1,0-2,5	5,3	9,5	17,5
3170017400	05219	1,0-2,5	6,5	12,0	22,0
3170017500	05221	1,0-2,5	8,4	14,0	21,0
3170017600	05223	1,0-2,5	10,5	18,5	24,0

### Terminale ad occhiello in ottone



- UNI 679 pesante.
- Spessore 0,8 mm.

Code	Desc.	Sez. cable	D1 mm.	D2 mm	L1 mm
3170005500	1798	3,0-6,0	6,4	14	32
3170005600	1800	3,0-6,0	8,4	14	32
3170005700	1802	4,0-6,0	10,5	18	36



## Power terminal to the brass eyelet



Code	Desc.	D. Holes mm	L1 leng. mm	L2 Width mm	A for cables mm <sup>2</sup>
3170003100	1414/6-16	6,3	29,5	11,5	16
3170003110	1414/8-16	8,4	33,5	15	16
3170003112	1414/10-16	10,5	37,5	18	16
3170003114	1414/12-16	13,2	42,5	20	16
3170003180	1415/6-25	6,4	32	14	25
3170003200	1415/8-25	8,4	36	15	25
3170003210	1415/10-25	10,5	40	18	25
3170003220	1415/12-25	13,2	45	21	25
3170003280	1416/6-35	6,4	38	16	35
3170003310	1416/8-35	8,4	38,5	17	35
3170003300	1416/10-35	10,5	42,5	19	35
3170003312	1416/12-35	13,2	47,5	21	35
3170003314	1416/8-50	8,4	42,5	19	50
3170003315	1416/10-50	10,5	46,5	20	50
3170003320	1416/12-50	13,2	51,5	21	50
3170003360	1417/8-70	8,4	50	21,8	70
3170003380	1417/10-70	10,5	50	21	70
3170003385	1417/12-70	13,2	55	22	70
3170003400	1417/14-70	15	59	25	70
3170003420	1417/14-95	15	65,5	25	95
3170003430	1417/16-95	17	69,5	27	95

## Naked terminals fork tinned copper



- Tinned copper material

Code	Description	Screw Ø	Cable sec. AWG mm <sup>2</sup>	F	B	L	D	A
3170026598	2,5-fork terminal sec.0,25-1,5	2,5	0,25-1,5	2,6	5,6	14,6	1,95	5,2
3170026601	3-fork terminal sec.0,25-1,5	3	0,25-1,5	3,2	5,6	14,6	1,95	5,2
3170026604	3,5-fork terminal sec.0,25-1,5	3,5	0,25-1,5	3,7	6,5	14,9	1,95	5,2
3170026607	4-fork terminal sec.0,25-1,5	4	0,25-1,5	4,2	6,5	15,7	1,95	5,2
3170026610	5-fork terminal sec.0,25-1,5	5	0,25-1,5	5,2	8	16,25	1,95	5,2
3170026613	6-fork terminal sec.0,25-1,5	6	0,25-1,5	6,2	9	17,5	1,95	5,2
3170026616	2,5-fork terminal sec.1,5-2,5	2,5	1,5-2,5	2,6	5,6	17,25	2,45	5,2
3170026619	3-fork terminal sec.1,5-2,5	3	1,5-2,5	3,2	5,6	17,25	2,45	5,2
3170026622	3,5-fork terminal sec.1,5-2,5	3,5	1,5-2,5	3,7	6,5	14,3	2,45	5,2
3170026625	4-fork terminal sec.1,5-2,5	4	1,5-2,5	4,2	6,5	15,7	2,45	5,2
3170026628	5-fork terminal sec.1,5-2,5	5	1,5-2,5	5,2	9,1	19,25	2,45	5,2
3170026631	6-fork terminal sec.1,5-2,5	6	1,5-2,5	6,2	10	21	2,45	5,2

## Assortment cable lugs glued male + female



- Contents: 12 measures cable lugs glued naked male and female from step 2.5 to step 9.5.
- Total 286 pieces.
- Supplied in a plastic carrying case our cod. 398 00 01700 200.

Code	Desc.
3170100200	12

Contenuto kit

CODICE	DESCRIZIONE	Q.tà
3170002600	1403-FASTON FEMMINA OTT.1-2.5	100
3170002700	1404-FASTON FEM.DENTE OT.1-2.5	100
3170004600	1439-FASTON MASCHIO OTTONE 6.3	50
3170002900	1410-FASTON FEMMINA PASSO 2.8	50
3170021820	52387-TERMINALE MASCHIO 2.8	50
3170003000	1413-FASTON MASCHIO LUNGO DENT	50
3170016000	05143-TERMINALE DOPPIO INNESTO	25
3170007300	18638-FASTON FEMMINA PASSO 4.7	25
3170021610	52345-FASTON MASCHIO PASSO 4.7	25
3170003900	1423-FASTON FEMMINA PASSO 9.5	20
3170021625	52348-TERMINALE ANTISFIL.DIRIT	90
3170003820	1422/1-FASTON MASCH.DENTE 9.5	50

## Assortment cable lugs naked eyelet



- Contents: 12 measures cable lugs bare eyelet diameter from 4 to diameter 10
- Supplied in plastic case our cod. 398 00 01700-200

Code	Desc.
3170100500	12

Contenuto kit

CODICE	DESCRIZIONE	Q.tà
317 00 17200	05215-OCCHIELLO 4 SEZ.1.5-2.5	25
317 00 21875	52398-TERMINALE OCCHIELLO 4.3	25
317 00 16700	05205-OCCHIELLO 5 SEZ.05-1	25
317 00 21880	52399-TERMINALE OCCHIELLO 5.4	25
317 00 17300	05217-OCCHIELLO 5 SEZ.1.5-2.5	25
317 00 16800	05207-OCCHIELLO 6 SEZ.0.5-1	25
317 00 17400	05219-OCCHIELLO 6 SEZ.1.5-2.5	25
317 00 16900	05209-OCCHIELLO 8 SEZ.0.5-1	25
317 00 17500	05221-OCCHIELLO 8 SEZ.1.5-2.5	25
317 00 05600	1800-CAPOCORDA OCCHIELLO 8	12
317 00 05700	1802-CAPOCORDA OCCHIELLO 10	12
317 00 17600	05223-OCCHIELLO 10 SEZ.1.5-2.5	25
398 00 01700	200 VALIGETTA 12 POSTI	1



## Tube pre-insulated terminals

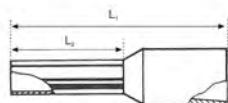

- Tinning copper with polypropylene insulation.
- According to DIN 46228/4 and DIN 47002.
- Ideal for panel builders and electrical harness making.

Code	Desc.	SEZ. mm <sup>2</sup>	L1 mm	L2 mm	Color
3170025000	52600	0,50	12	6	WHITE
3170025010	52601	0,50	14	8	WHITE
3170025020	52602	0,75	12,4	6	GREY
3170025030	52603	0,75	14,6	8,2	GREY
3170025040	52604	1,00	12,4	6	RED
3170025050	52605	1,00	14,6	8,2	RED
3170025060	52606	1,5	14,6	8,2	BLACK
3170025070	52607	1,5	16,6	10	BLACK
3170025080	52608	2,5	15,2	8,2	BLUE
3170025090	52609	2,5	19,0	12,0	BLUE
3170025100	52610	4,0	16,0	9,0	GREY
3170025110	52611	4,0	19,5	12,0	GREY
3170025120	52612	6,0	20,0	12,0	YELLOW
3170025130	52613	6,0	26,0	18,0	YELLOW
3170025140	52614	10,0	21,5	12,0	RED
3170025150	52615	10,0	27,5	18,0	RED
3170025160	52616	16,0	22,7	12,0	BLUE
3170025170	52617	16,0	28,6	18,0	BLUE
3170025190	52619	25,0	35,0	22,0	YELLOW
3170025200	52620	35,0	30,0	16,0	RED
3170025210	52621	35,0	39,0	25,0	RED
3170025220	52622	50,0	36,0	20,0	BLUE
3170025230	52623	50,0	41,0	25,0	BLUE

## Terminals tube pre-insulated double pinch

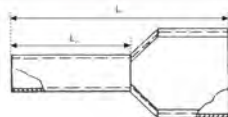

- Terminals built tinning copper with insulating polypropylene.
- Designed to be used where there is need for a safe and rapid derivation.
- The wide seat easily invite accepts two cables.
- Available for cable diameter from 0.50 to 16 mm<sup>2</sup>.
- Coloring system in accordance with DIN 47002.

Code	Desc.	SEZ. mm <sup>2</sup>	L1 mm	L2 mm	Color
3170025240	52624	2 x 0,50	15,0	8,0	WHITE
3170025250	52625	2 x 0,75	15,0	8,0	GREY
3170025260	52626	2 x 1,00	15,0	8,0	RED
3170025270	52627	2 x 1,50	16,0	8,0	BLACK
3170025280	52628	2 x 2,50	18,5	10,0	BLUe
3170025290	52629	2 x 4,00	23,0	12,0	GREY
3170025300	52630	2 x 6,00	26,0	14,0	YELLOW
3170025310	52631	2 x 10,0	26,0	14,0	RED
3170025320	52632	2 x 16,00	30,0	14,0	BLUE

## Set terminals in pre-insulated pipe



- Tinning copper terminals with insulating polypropylene complies with DIN 46228/4 and DIN 47002.
- ideal for panel builders and electrical harness making

Code	Desc.
3170101400	44100

	CODICE	COLORE	SEZIONE mm <sup>2</sup>	L1 mm	L2 mm	Q.TÀ
TERMINALI SINGOLI	3170025000	BIANCO	0,5	12	6	100
	3170025020	GRIGIO	0,75	12,4	6	100
	3170025040	ROSSO	1	12,4	6	100
	3170025060	NERO	1,5	14,6	8,2	100
	3170025080	BLU	2,5	15,2	8,2	100
	3170025100	GRIGIO	4	16	9	100
	3170025120	GIALLO	6	20	12	25
	3170025140	ROSSO	10	21,5	12	25
	3170025160	BLU	16	22,7	12	25
	3170025180	GIALLO	25	29	16	10
	3170025200	ROSSO	35	30	16	10
DOPPIO INVITO	3170025240	BIANCO	0,5	15	8	100
	3170025250	GRIGIO	0,75	15	8	100
	3170025260	ROSSO	1	15	8	100
	3170025270	NERO	1,5	16	8	100
	3170025280	BLU	2,5	18,5	10	50
	3170025290	GRIGIO	4	23	12	20
	3170025300	GIALLO	6	26	14	20

## Insulated terminals for cable sect. 00:25 - 1,5 mm<sup>2</sup>

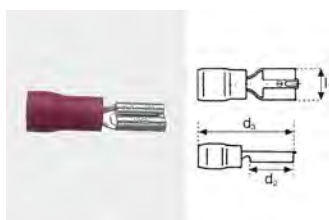

- Female 2.8mm pitch.

Code	Desc.	L1 mm	D2 mm	D3 mm	Material
3170011000	35414	2,8	8	17,5	Tinned brass

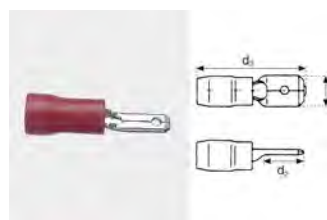

- Male 2.8mm pitch.

Code	Desc.	L1 mm	D2 mm	D3 mm	Material
3170010100	35144	2,8	5,5	14,6	Tinned brass

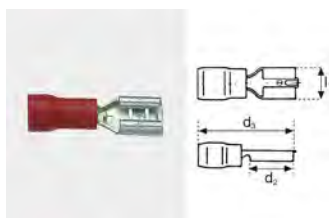

- Female step 4.7 mm

Code	Desc.	L1 mm	D2 mm	D3 mm	Material
3170010900	35313	4,7	6	18	Tinned brass

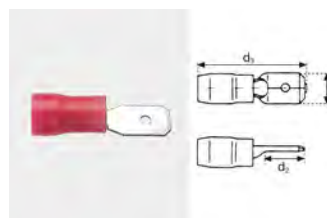

- Male step 4.7 mm.

Code	Desc.	L1 mm	D2 mm	D3 mm	Material
3170022100	52443	4,7	6	18	Tinned brass

3

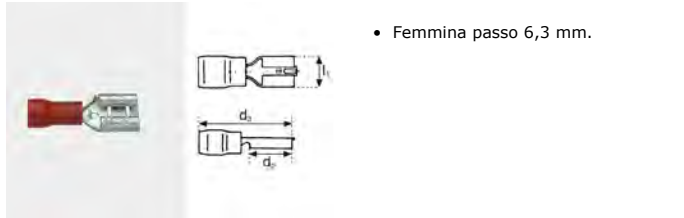

• Femmina passo 6,3 mm.

Code	Desc.	L1 mm	D2 mm	D3 mm	Material
3170009400	35040	6,3	7,5	22	Tinned brass

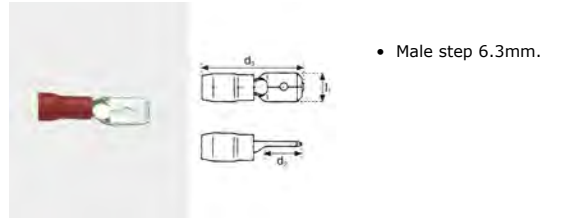

• Male step 6.3mm.

Code	Desc.	L1 mm	D2 mm	D3 mm	Material
3170009900	35135	6,3	8	22	Tinned brass

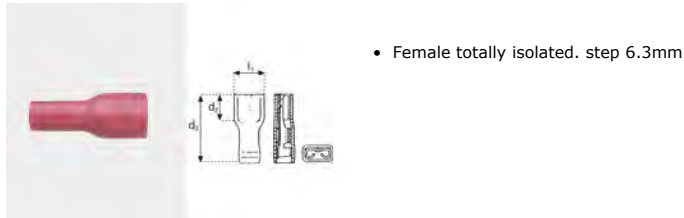

• Female totally isolated. step 6.3mm

Code	Desc.	L1 mm	D2 mm	D3 mm	Material
3170010300	35180	6,3	7.5	21	Tinned brass

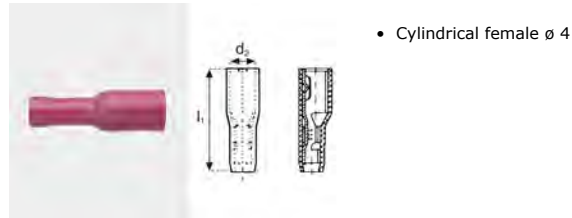

• Cylindrical female ø 4

Code	Desc.	L1 mm	D2 mm	D3 mm	Material
3170009000	35004	22	ø4	-	Tinned brass

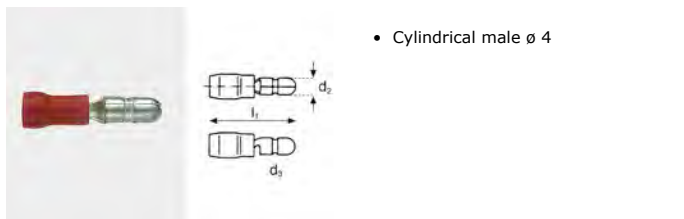

• Cylindrical male ø 4

Code	Desc.	L1 mm	D2 mm	D3 mm	Material
3170009300	35038	22	ø 4	9	Tinned brass

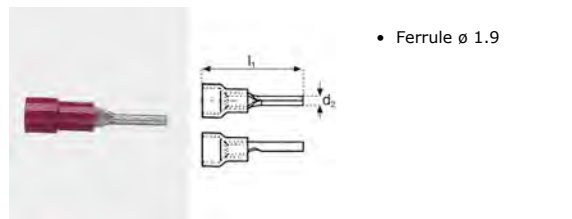

• Ferrule ø 1.9

Code	Desc.	L1 mm	D2 mm	Material
3170014700	39175	22	ø 1,9	Tinned brass

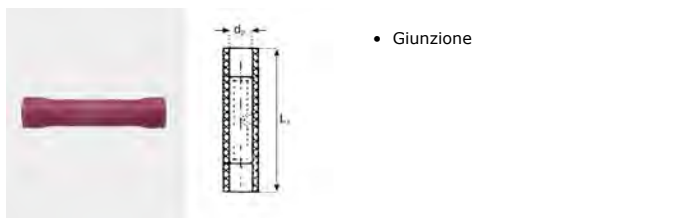

• Giunzione

Code	Desc.	L1 mm	D2 mm	Material
3170008500	34016	15	3,6	Tinned Brass
3170008700	34528	25	3,6	Tinned Brass

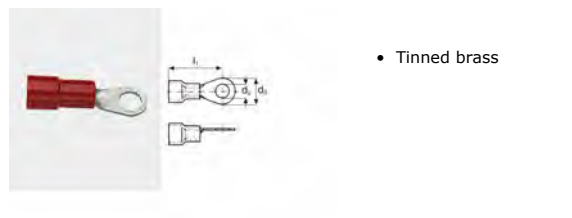

• Tinned brass

Code	Desc.	L1 mm	D2 mm	D3 mm	Thickness mm
3170011600	39102	17,0	3,7	6,0	0,8
3170011700	39103	18,0	4,3	8,0	0,8
3170011800	39104	19,0	5,3	10,0	0,8
3170014400	39172	20,0	6,5	10,0	0,8
3170014500	39173	23,5	8,4	14,0	0,8

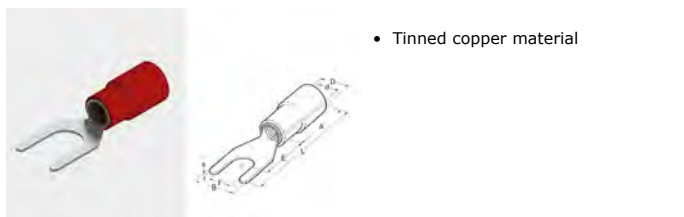

• Tinned copper material

Code	Description	Screw Ø	Cable sec. AWG mm2	F	B	A	E	L	d	D
3170026634	2,5-red fork terminal sec.0,25-1,5	2,5	0,25-1,5	2,6	5,6	10,4	6,7	20	1,95	4,2
3170026637	3-red fork terminal sec.0,25-1,5	3	0,25-1,5	3,2	5,6	10,4	6,7	20	1,95	4,2
3170026640	3,5-red fork terminal sec.0,25-1,5	3,5	0,25-1,5	3,7	6,5	10,4	6,5	19,4	1,95	4,2
3170026643	4-red fork terminal sec.0,25-1,5	4	0,25-1,5	4,2	6,4	10,4	6,3	20,9	1,95	4,2
3170026646	5-red fork terminal sec.0,25-1,5	5	0,25-1,5	5,2	8	10,4	8	21,2	1,95	4,2
3170026649	6-red fork terminal sec.0,25-1,5	6	0,25-1,5	6,2	9,2	10,4	8,3	22,4	1,95	4,2

## Insulated terminals for cable sect. 1,5 - 2.5 mm<sup>2</sup>

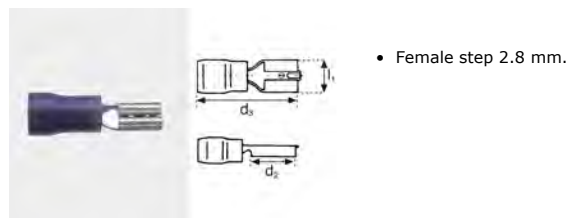

• Female step 2.8 mm.

Code	Desc.	L1 mm	D2 mm	D3 mm	Material
3170022105	52444	2,8	8	17,5	Tinned brass

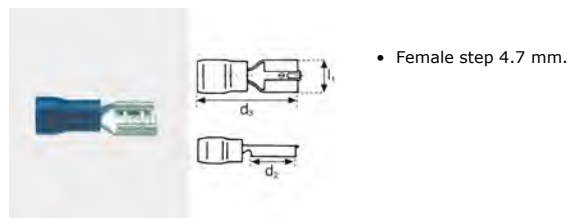

• Female step 4.7 mm.

Code	Desc.	L1 mm	D2 mm	D3 mm	Material
3170010800	35312	4,7	6	18	Tinned brass

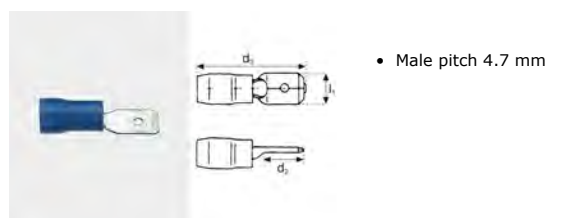

• Male pitch 4.7 mm

Code	Desc.	L1 mm	D2 mm	D3 mm	Material
3170022110	52445	4,7	6	18	Tinned brass

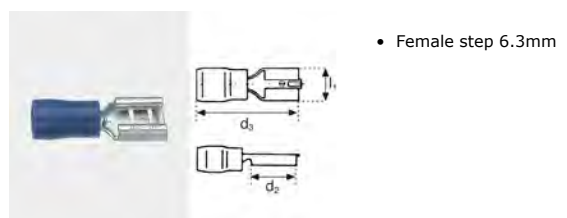

• Female step 6.3mm

Code	Desc.	L1 mm	D2 mm	D3 mm	Material
3170009200	35032	6,3	7,4	21	Tinned brass

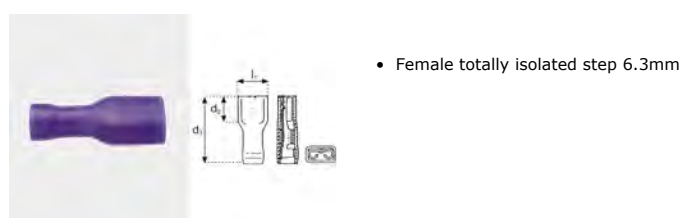

• Female totally isolated step 6.3mm

Code	Desc.	L1 mm	D2 mm	D3 mm	Material
3170010200	35179	6,3	7,5	21	Tinned brass

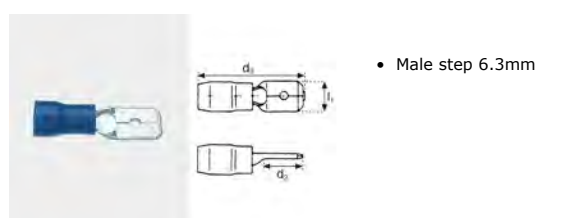

• Male step 6.3mm

Code	Desc.	L1 mm	D2 mm	D3 mm	Material
3170010400	35259	6,3	8	22	Ottone stagnato

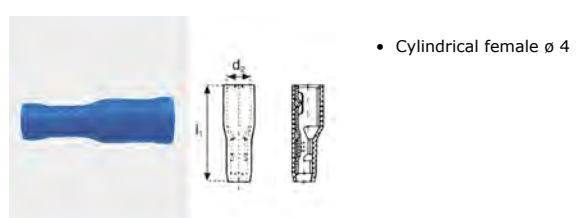

• Cylindrical female ø 4

Code	Desc.	L1 mm	D2 mm	D3 mm	Material
3170021385	52301	22	4	-	Tinned brass

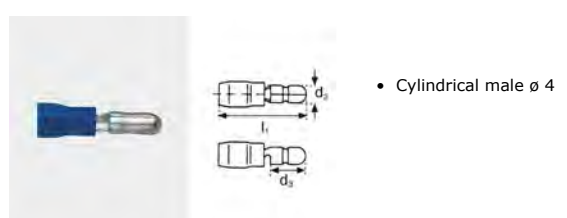

• Cylindrical male ø 4

Code	Desc.	L1 mm	D2 mm	D3 mm	Material
3170021400	52303	22	4	-	Tinned brass

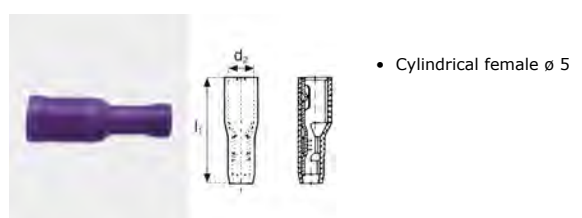

• Cylindrical female ø 5

Code	Desc.	L1 mm	D2 mm	D3 mm	Material
3170009100	35005	22	5	-	Tinned brass

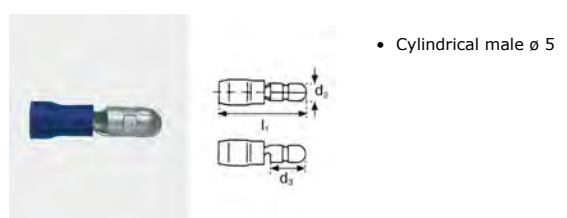

• Cylindrical male ø 5

Code	Desc.	L1 mm	D2 mm	D3 mm	Material
3170009500	35042	22	5	9	Tinned brass

3

3

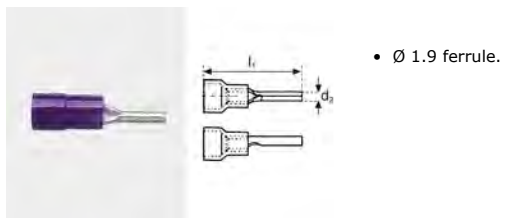

Code	Desc.	L1 mm	D2 mm	Material
3170013000	39122	17	1,9	Tinned brass
3170014800	39176	22	1,9	Tinned Brass

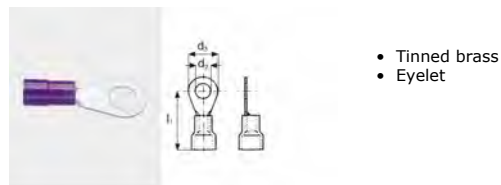

Code	Desc.	L1 mm	D2 mm	D3 mm
3170013500	39161	18	3,7	6
3170012000	39106	18	4,3	8
3170012100	39107	20	5,3	10
3170012200	39108	22	6,5	11
3170012300	39109	23	8,4	14
3170015400	39471	26	10,5	15

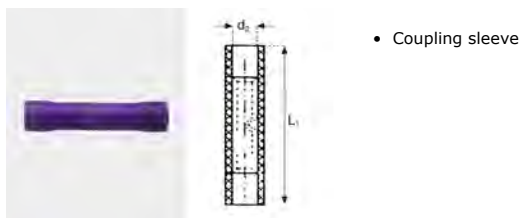

Code	Desc.	L1 mm	D2 mm	Material
3170008800	34529	25	4,3	Tinned brass
3170008300	34001	15	4,3	Ottone stagnato

## Terminali preisolati per cavi sez. 1 - 2.5 mm<sup>2</sup>



Code	Description	Screw Ø	Cable sec. AWG mm <sup>2</sup>	F	B	A	E	L	d	D
3170026652	2,5-blue fork terminal sec.1,5-2,5	2,5	1,5-2,5	2,6	5,6	11	8,4	23	2,45	4,8
3170026655	3-blue fork terminal sec.1,5-2,5	3	1,5-2,5	3,2	5,6	11	8,4	23	2,45	4,8
3170026658	3,5-blue fork terminal sec.1,5-2,5	3,5	1,5-2,5	3,7	6,6	11	5,3	20,3	2,45	4,8
3170026661	4-blue fork terminal sec.1,5-2,5	4	1,5-2,5	4,2	6,6	11	5,3	20,3	2,45	4,8
3170026664	5-blue fork terminal sec.1,5-2,5	5	1,5-2,5	5,2	9,1	11	9,5	25	2,45	4,8
3170026667	6-blue fork terminal sec.1,5-2,5	6	1,5-2,5	6,3	10,00	1	11,2	27	2,45	4,8

## Insulated terminals for cable sect. 2,5 - 6 mm<sup>2</sup>

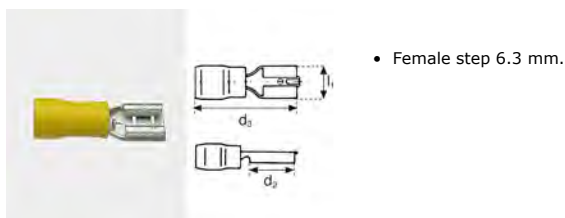

Code	Desc.	L1 mm	D2 mm	D3 mm	Material
3170009600	35047	6,3	7,5	22	Tinned brass

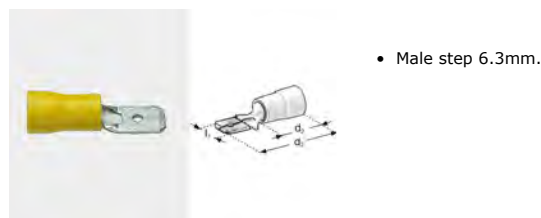

Code	Desc.	L1 mm	D2 mm	D3 mm	Material
3170010700	35285	6,3	8	22	Tinned brass





- Female totally isolated

Code	Desc.	L1 mm	D2 mm	D3 mm	Material
3170010650	35268	6,3	7,5	22	Ottone stagnato



- Female step 9.5mm

Code	Desc.	L1 mm	D2 mm	D3 mm	Material
3170010600	35266	9,5	12	26	Ottone stagnato

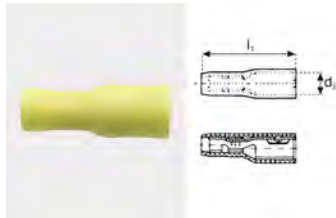

- Cylindrical female  $\varnothing$  5

Code	Desc.	L1 mm	D2 mm	D3 mm	Material
3170009700	35078	22	5	-	Tinned brass

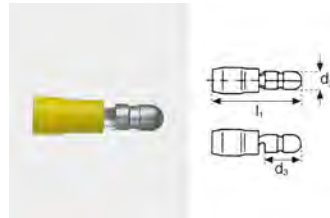

- Cylindrical male  $\varnothing$  5

Code	Desc.	L1 mm	D2 mm	D3 mm	Material
3170009800	35084	22	5	9	Tinned brass

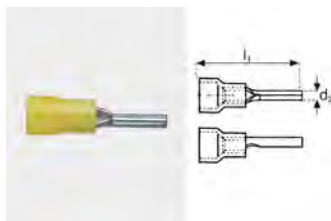

- Ferrule  $\varnothing$  2.9

Code	Desc.	L1 mm	D2 mm	D3 mm	Material
3170014900	39177	26	2,9	-	Tinned brass

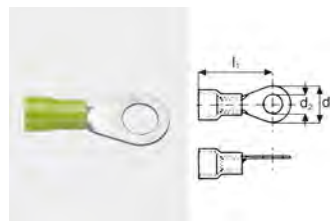

- Tinned brass
- Eyelet

Code	Desc.	L1 mm	D2 mm	D3 mm
3170012400	39110	20	4,3	8
3170012500	39111	21	5,3	10
3170012600	39112	22	6,5	11
3170012700	39113	25	8,4	14
3170012800	39114	27	10,5	18

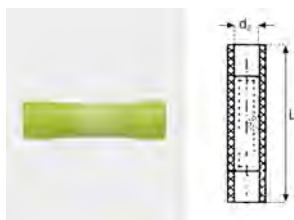

- Coupling sleeve.

Code	Desc.	L1 mm	D2 mm	D3 mm	Material
3170008900	34530	32	6	-	Tinned brass
3170008305	34003	20	6	-	Tinned Brass

## Terminali preisolati per cavi sez. 2.5 - 6 mm<sup>2</sup>



- Materiale rame stagnato
- Fork

Code	Description	Screw $\varnothing$	Cable sec. AWG mm <sup>2</sup>	F	B	A	E	L	d	D
3170026670	3,5-yellow fork terminal sec.4-6	3,5	4-6	3,7	8,1	14	7,2	26	3,5	6,6
3170026673	4-yellow fork terminal sec.4-6	4	4-6	4,2	8,1	14	7,2	26	3,5	6,6
3170026676	5-yellow fork terminal sec.4-6	5	4-6	5,2	9	14	10,5	28,5	3,5	6,6
3170026679	6-yellow fork terminal sec.4-6	6	4-6	6,3	11	14	11	29,5	3,5	6,6

## Assortment insulated connectors male + female



- Contents: 12 measures of pre-insulated male and female red yellow and blue various steps.
- Total 144 pieces.
- Supplied in a plastic carrying case our cod. 398 00 01700-200.

Code	Desc.
3170100300	12

**Contenuto kit**

CODICE	DESCRIZIONE	Q.tà
3170010700	35285-FASTON M.GIALLO	12
3170009600	35047-FASTON F.GIALLO	12
3170009800	35084-BOCCOLA M.GIALLO	12
3170009700	35078-BOCCOLA F.GIALLA	12
3170011000	35414-FASTON F.FROSSO	12
3170010100	35144-FASTON M.PROSSO	12
3170009400	35040-FASTON F.FROSSO	12
3170009900	35135-FASTON M.ROSSO	12
3170022110	52445-FASTON M.BLEU	12
3170010800	35312-FASTON F.BLEU	12
3170010400	35259-FASTON M.BLEU	12
3170009200	35032-FASTON F.BLEU PASSO 6.3	25

## Assortment insulated terminals



- Assortment insulated terminals
- Contents: 12 measures of insulated connectors yellow, red and blue diameter 4 to 8 diameter.
- Total 144 pieces.
- Supplied in a plastic carrying case our cod. 398 00 01700-200.

Code	Desc.
3170100100	12

**Contenuto kit**

CODICE	DESCRIZIONE	Q.tà
317 00 12400	39110-OCCHIELLO GIALLO 4	12
317 00 12500	39111-OCCHIELLO GIALLO 5	12
317 00 12600	39112-OCCHIELLO GIALLO 6	12
317 00 12700	39113-OCCHIELLO GIALLO 8	12
317 00 11700	39103-OCCHIELLO ROSSO 4	12
317 00 11800	39104-OCCHIELLO ROSSO 5	12
317 00 14400	39172-OCCHIELLO ROSSO 6	12
317 00 14500	39173-OCCHIELLO ROSSO 8	12
317 00 12000	39106-OCCHIELLO BLEU 4	12
317 00 12100	39107-OCCHIELLO BLEU 5	12
317 00 12200	39108-OCCHIELLO BLEU 6	12
317 00 12300	39109-OCCHIELLO BLEU 8	12

## Insulated terminals polyolefin heat shrinkable cable section 0.5 - 1.5



- Heat Shrink
- Female step 6.3 mm.

Code	Desc.	Step	Color	Material
3160000300	402	6,3	Red	Tinned brass



- Heat Shrink
- Male step 6.3mm.

Code	Desc.	Step	Color	Material
3160000400	403	6,3	Red	Tinned brass



- Heat Shrink
- Coupling sleeve

Code	Desc.	Diam. mm	Color	Material
3160000500	404	-	Red	Tinned brass



- Heat Shrink
- Fork

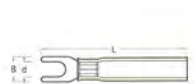

Code	Description	Cable sec. AWG mm <sup>2</sup>	d	B	L
3160002515	4,3-red heat shrink terminal 0,5-1,5	0,5-1,5	4,3	7,2	26,9
3160002520	5,3-red heat shrink terminal 0,5-1,5	0,5-1,5	5,3	9,5	26,9

## Totally insulated female terminals with heat shrink tube step 6,3



- Female

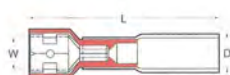

Code	Description	Cable sec. AWG mm <sup>2</sup>	W	D	L
3160002565	R-Insu. heat shrink fem. termin. 0,5-1,5	0,5-1,5	6,6	6,5	36,5

3

3



- Male

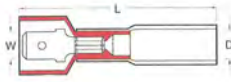

Code	Description	Cable sec. AWG mm <sup>2</sup>	W	D	L
3160002580	R- Insu. heat shrink male termin.0,5-1,5	0,5-1,5	6,35	6,5	38,5

## Insulated terminals polyolefin heat shrink tubing cable section 1.5 - 2.5



- Heat Shrink
- Male step 6.3.
- Tinned brass.

Code	Desc.	Step	Color
3160000900	503	6,3	BLUE



- Heat Shrink
- Female step 6.3mmT
- Tinned brass

Code	Desc.	Step	Color
3160000800	502	6,3	BLUE



- Heat Shrink
- Eyelet.
- Tinned brass.

Code	Desc.	Diam. mm	Color
3160000600	500-4	4	BLUE
3160000605	500-5	5	BLU
3160000610	500-6	6	BLU
3160000615	500-8	8	BLU



- Heat Shrink
- Coupling sleeve
- Tinned brass

Code	Desc.	Diam. mm	Color
3160001000	504	-	BLUE



- Heat Shrink
- Fork

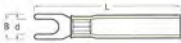

Code	Description	Cable sec. AWG mm <sup>2</sup>	d	B	L
3160002545	4,3-blue heat shrink terminal 1,5-2,5	1,5-2,5	4,3	7,2	26,5
3160002550	5,3-blue heat shrink terminal 1,5-2,5	1,5-2,5	5,3	8	26,5
3160002555	6,4- blue heat shrink terminal 1,5-2,5	1,5-2,5	6,4	10,7	27,5

## Totally insulated female terminals with heat shrink tube step 6,3



- Female

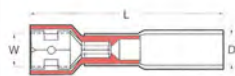

Code	Description	Cable sec. AWG mm2	W	D	L
3160002570	B-Insu. heat shrink fem. termin. 1,5-2,5	1,5-2,5	6,6	6,5	36,5



- Male

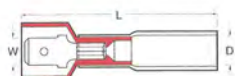

Code	Description	Cable sec. AWG mm2	W	D	L
3160002585	B- Insu. heat shrink male termin. 1,5-2,5	1,5-2,5	6,35	6,5	39,5

## Terminals polyolefin heat shrink cable section 2,5-6 mm2



- Heat Shrink
- Eyelet.
- Tinned brass.



- Heat Shrink
- Coupling sleeve
- Tinned brass

Code	Desc.	Diam. mm	Color
3160001105	600-5	5	YELLOW
3160001110	600-6	6	GIALLO
3160001115	600-8	8	GIALLO
3160001120	600-10	10	GIALLO

Code	Desc.	Diam. mm	Color
3160001300	602	-	YELLOW

## Totally insulated female terminals with heat shrink tube step 6,3



- Female

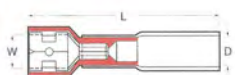

Code	Description	Cable sec. AWG mm2	W	D	L
3160002575	G-Insu. heat shrink fem. termin. 4-6	2,5-6,0	6,6	7,5	37,00



- Male

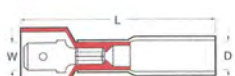

Code	Description	Cable sec. AWG mm2	W	D	L
3160002590	G- Insu. heat shrink male termin. 4-6	2,5-6,0	6,35	7,5	39,5



## Self sealing sleeves



- Junction sleeves self-sealing newly developed polyolefin totally free of cadmium.
- Product suitable for all players in the electricity sector in general.
- Indicated for the union of electrical cables with a diameter of 0.3 to 10 mm<sup>2</sup> at an operating temperature of about + 85 ° C.
- To be used in combination with hot air tool our code. 417 00 16170 HG 2320 E

Code	Desc.	Application cable section MMQ	Color
3160002100	803N	0,3-0,8	Neutral
3160002200	804	0,8-2,0	Red
3160002300	805	2,0-4,0	Blue
3160002400	806	4,0-6,0	Yellow
3160002500	807	6,0-10	Grey

## Tail connectors waterproof



- Tail connectors waterproof
- Suitable for the protection of cables from 0.7 to 8 mm<sup>2</sup>.
- To isolate and protect even more cables without the need for collets.
- Suitable for all players in the electricity sector.

Code	Desc.	For cables sect. mm <sup>2</sup>	Color
3160001800	801	0,7-2,4	GREEN
3160001900	802	2,0-4,0	RED
3160002000	803	3,5-8,0	BLUE

**ISTRUZIONI PER L'USO:** Per effettuare le giunzioni dei cavi è necessario un termosoffiatore tipo il n/s modello 4170016170 HG 2320 E con l'ugello a riflettore art. 417 RC 01320-53 utilizzando una temperatura di circa 450° posizionare il giunto nell'ugello, il calore farà sciogliere l'anello di stagno e la guaina isolante si restringerà sul conduttore garantendo la tenuta della giunzione

### MANICOTTI

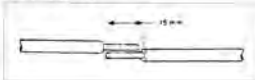

Spelare i cavi come da disegno. Inserire le estremità nei giunti di coda e posizionarli sotto l'anello di stagno. Con il calore erogato dal termosoffiatore l'anello di stagno si scioglierà completamente e la guaina isolante si ritirerà fino al punto desiderato.

### CONNETTORI DI CODA ESEMPIO:

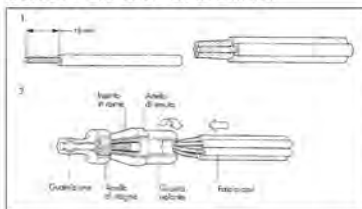

1. Eliminare 15mm di isolante da tutti i cavi che devono essere uniti.
2. Allineare i cavi e formare un fascio.
3. Inserire il fascio nella estremità del giunto di coda e girare leggermente, con la rotazione la spirale di rame del giunto si blocca trattenendo il fascio di cavi precedentemente spelati.
4. Riscaldare il giunto di coda con il termosoffiatore nella zona della spirale di rame fino a quando l'anello di stagno si fonderà e penetrerà fino al centro del fascio di cavi. Controllare poi che la guaina isolante, ritirandosi abbia isolato completamente i cavi.



## Clamps flying in slats

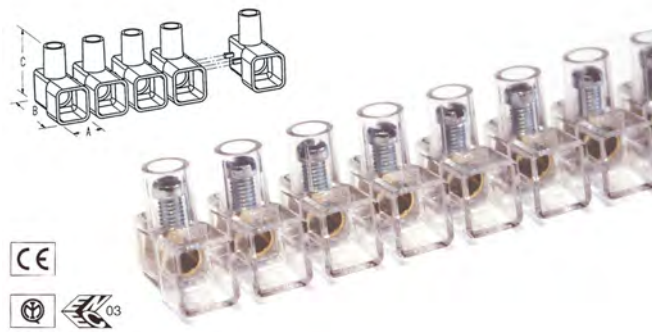

- Terminal blocks flying for electrical connections, polycarbonate connector brass OT58, tightening screws galvanized steel captive.
- Packaged in convenient cartons of 10 pieces up to 10 mm<sup>2</sup> section. 5-piece section 16 mm<sup>2</sup>.
- CONSTRUCTION IN COMPLIANCE WITH STANDARDS:
- EN 60998-1: 1993 + A1 / 2001
- EN 60998-2-1: 1993
- EN 60998-2-2: 1993
- Resistance to heat up to + 130 ° C. Operating temperature -5 ° C to + 85 ° C.
- IP20 degree of protection to the section 10 mm<sup>2</sup>. IP00 for section 16 mm<sup>2</sup>.

3

Il morsetto che non punge le dita!!! sistema di separazione brevettato



Viti imperdibili e con ottimo serraggio uniforme e sicuro



Maggiore spazio nel corpo isolante



Code	Desc.	SEZ. mm <sup>2</sup>	Hole diam. mm	A mm	B mm	C mm
3170025330	52633-1,5	1,5	3,2	9	16	15
3170025340	52634-2,5	2,5	4,0	10	20	18
3170025345	52634-4	4	4,5	11	22	20
3170025350	52635-6	6	6	12	25	22
3170025360	52636-10	10	7,5	14	29	26
3170025370	52637-16	16	9,5	19	35	31

## Flying individual Clamps



Code	Desc.	SEZ. mm <sup>2</sup>	Hole diam. mm	A mm	B mm	C mm
3170025335	52633-S	1,5	3,2	9	16	15
3170025343	52634-S	2,5	4,0	10	20	18
3170025347	52634-4S	4	4,5	11	22	20
3170025355	52635-S	6	6	12	25	22
3170025365	52636-S	10	7,5	14	29	26
3170025372	52637-25	25	12	22	39	40
3170025374	52637-35	35	14	24	46	43

- Terminal blocks flying for electrical connections, polycarbonate connector brass OT58, tightening screws galvanized steel captive.
- Loosely packaged and already separated individually.
- CONSTRUCTION IN COMPLIANCE WITH STANDARDS:
- EN 60998-1: 1993 + A1 / 2001
- EN 60998-2-1: 1993
- EN 60998-2-2: 1993
- Resistance to heat up to + 130 ° C. Operating temperature -5 ° C to + 85 ° C.
- IP20 degree of protection to the section 10 mm<sup>2</sup>. IP00 for larger.

## Terminal blocks double flying

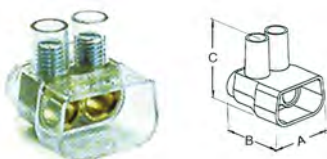

Code	Descr. measure mmq	SEZ. mm <sup>2</sup>	D. Holes mm	A mm	B mm	C mm
3170025600	52660-2x16	2x16	5,5	20,5	22,6	24,5
3170025605	52660-2x25	2x25	7	25	26,2	25,4
3170025610	52660-2x35	2x35	9	32	31,2	33,4

## Terminal blocks plug male and female



Code	Desc.	Cable sec. mm <sup>2</sup>	N° Way
3150000150	12 MF	2.5	12
3150000250	20 MF	4	12

## Screw terminals VDE IMQ standards

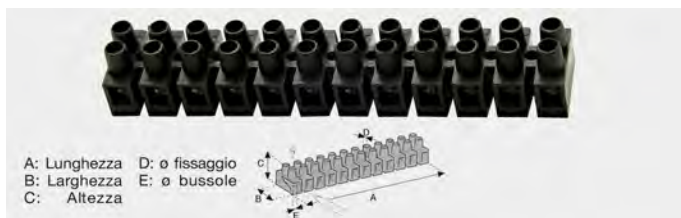

Code	Desc.	Cable sec. mm <sup>2</sup>	Intensity nominal	Voltage Volt	Temperature °C	A	B	C	D	E	N° Way
3150000100	12	2,5	24 A	380	85	94,9	16,4	14,5	2,5	2,8	12
3150000200	20	4	32 A	380	85	117,3	20,1	17,6	3,2	3,2	12
3150000300	30	10	57 A	450	85	139,8	23,1	20,1	4,2	4,2	12

## Self shelled insulation displacement Clamps (electrical tap connector)



- With double foil.

Code	Desc.	For cables sect. mm <sup>2</sup>	voltage max V.
3140000110	563	0.5÷1,5	600

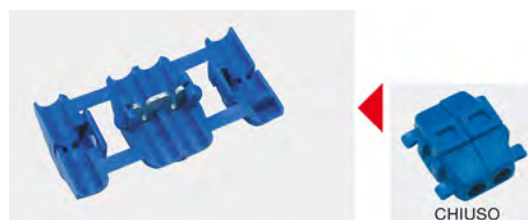

Code	Desc.	For cables sect. mm <sup>2</sup>
3140000500	1009/1	1÷2.5



Code	Description	SEZ. mm <sup>2</sup>	voltage max V.
3140000111	563/1 RED	0,5÷1	400
3140000200	564 BLUE	1÷2,5	400



Code	Desc.	For cables sect. mm <sup>2</sup>	voltage max V.
3140000300	580	2.5÷6	400

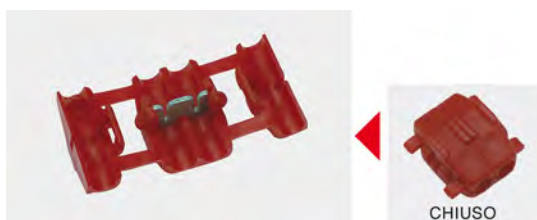

Code	Desc.	For cables sect. mm <sup>2</sup>
3140000400	1009	0.25÷0.75

## Derivations "C"

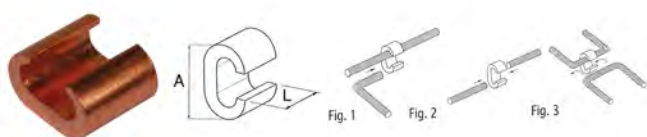

- Junction c copper red.
- To be used where it is necessary to create diversions ensuring continuity.

Code	Desc.	SEZ. mm <sup>2</sup>	A	L	Straight derivations to "T" <i>PASSING pic.1-2</i>	Straight derivations cross <i>SECTION mm2 pic.3</i>	Straight derivations to "T" <i>DERIVED pic.1-2</i>
3170030030	53100 - 10-10	10-10	12,6	12	10	-	10-1,5
3170030040	53110 - 16-16	16-16	19,4	17,5	16	-	16-2,5
3170030050	53120 - 25-25	25-25	21,4	17,5	25	-	25-16
3170030060	53130 - 35-35	35-35	26,6	21,5	40-35	35-35	40-25
3170030070	53140 - 50-50	50-50	33	26,5	50	-	50-35
3170030080	53150 - 70-70	70-70	34	27	70-50	50-50	70-35

## Universal comb 1 bolt



- Clamps cast brass.
- To be used where it is necessary to create diversions ensuring continuity.

Code	Desc.	SEZ. mm <sup>2</sup>	A	B	L	Ø cavi
3170030090	53160 - 6-16	6 - 16	5	25,5	20,5	3-5
3170030100	53170 - 25-50	25 - 50	9	29,5	25-16	6-8
3170030110	53180 - 50-70	50 - 70	12	37,5	30	9-12

## Universal comb 2 bolts

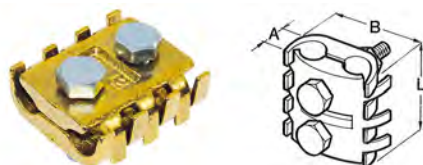

- Clamps cast brass.
- To be used where it is necessary to create diversions ensuring continuity.

Code	Desc.	SEZ. mm <sup>2</sup>	A	B	L	Ø cavi
3170030120	53190 - 6-16	6 - 16	5	25	32	3 - 5
3170030130	53200 - 25-50	25 - 50	9	32	38	6 - 8
3170030140	53210 - 50-70	50 - 70	12	42	45	9-12
3170030150	53220 - 70-95	70 - 95	14	53	53	12 - 14

## RJ connectors phone



- Connectors rj category sixth or lower.
- Shell polycarbonate ul 94-v2.
- Phosphor bronze contacts with gold plating 50 micro inches.
- For use with our clamp cod. 317 00 00331.

Code	Desc.	Attachment
3170030000	53000-RJ22	4P - 4C
3170030010	53010-RJ11/RJ14	6P - 4C
3170030020	53020-RJ12	6P - 6C



PINZA COD. 3170000331

## Quick release battery Clamps to screw



- Quick release clamps with plastic shell.
- Model to screw, brass clamps 12 microns, resistant to corrosion, with 316 stainless steel screw.
- Suitable for all DIN and SAE standard batteries.
- The battery can be easily disconnected and moved to another vehicle, car, boat, or be removed during the winter.
- Compared to the conventional terminals, they do not require any tools to make the connection on the battery.
- Allow you to disconnect the battery in a matter of seconds, with extreme ease of use, so as to prevent the download.
- Also allow installation of batteries located in areas difficult.
- Applications: cars, trucks, boats, caravans, campers, trucks, construction equipment, agriculture, construction equipment, laboratories, emergency lighting, etc.
- Product suitable for: drivers, workshops VI and car bodies VI, agricultural, earthmoving, campers, marine engine repair workshop, docks and port services.

Code	Desc.	Polarity	Color	Cable sec. mm <sup>2</sup>
2990005500	5036P	+	Rosso	Fino a 35
2990005510	5037N	-	Blu	Fino a 35



## Quick release battery Clamps crimp



- Quick release clamps with plastic shell.
- Model crimp, brass clamps 12 microns, resistant to corrosion.
- Suitable for all DIN and SAE standard batteries.
- The battery can be easily disconnected and moved to another vehicle, boat, or be removed during the winter.
- Compared to the conventional terminals, they do not require any tools to make the connection on the battery.
- Allow you to disconnect the battery in a matter of seconds, with extreme ease of use, so as to prevent the download.
- Also allow installation of batteries located in areas difficult.
- Applications: trucks, boats, trucks, construction equipment, agriculture, construction equipment, laboratories, emergency lighting, etc.
- Product suitable for: drivers, workshops VI, VI bodies, agriculture, construction, marine engine repair workshop, docks and port services.
- For tightening the terminal it is advisable to use our pipe clamp terminals, cod. 3170000337 to 795.

3

Code	Desc.	Polarity	Color	Cable sec. mm <sup>2</sup>
2990005520	5038P	+	Red	20 - 40
2990005530	5039N	-	Blue	20 - 40
2990005540	5040P	+	Rosso	40 - 70
2990005550	5041N	-	Blu	40 - 70

## Battery terminals

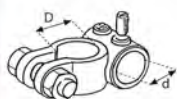

- Brass casting.

Code	Desc.	For cables sect. mm <sup>2</sup>	Polarity	Ø cable loc. d mm	Int. Diam. D mm
2990000500	600 P	25	+	10	17,5
2990000600	601 N	25	-	10	16
2990000100	6 P	50	+	12	17,5
2990000200	7 N	50	-	12	16

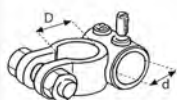

- Galvanized brass nautical

Code	Desc.	For cables sect. mm <sup>2</sup>	Polarity	Ø cable loc. d mm	Int. Diam. D mm
2990000700	5786 P	25	+	10	17,5
2990000800	5787 N	25	-	10	16

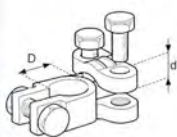

- Brass casting

Code	Desc.	For cables sect. mm <sup>2</sup>	Polarity	Ø cable loc. d mm	Int. Diam. D mm
2990005060	5023 P	25÷50	+	12,5 max	17,5
2990005070	5024 N	25÷50	-	12,5 max	16

3

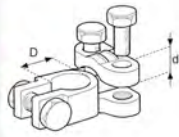

- Brass painted red. Positive.

Code	Desc.	For cables sect. mm <sup>2</sup>	Polarity	Ø cable loc. d mm	Int. Diam. D mm
2990004500	5012 P	P 16÷35	+	12,5	19

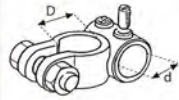

- Brass painted blue. Negative.

Code	Desc.	For cables sect. mm <sup>2</sup>	Polarity	Ø cable loc. d mm	Int. Diam. D mm
2990004600	5013 N	16÷35	-	12,5	17

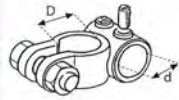

- Brass casting.
- Type Alfa right.

Code	Desc.	For cables sect. mm <sup>2</sup>	Polarity	Ø cable loc. d mm	Int. Diam. D mm
2990000610	610 P	16-35	+	12,5	19
2990000620	620 N	16-35	-	12,5	17

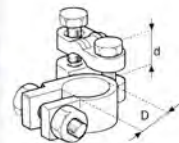

- Brass casting

Code	Desc.	For cables sect. mm <sup>2</sup>	Polarity	Ø cable loc. d mm	Int. Diam. D mm
2990000300	60 P	25÷50	+	12,5	19
2990000400	70 N	25÷50	-	12,5	17

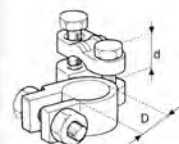

- Zinc-plated brass. For boating.

Code	Desc.	For cables sect. mm <sup>2</sup>	Polarity	Ø cable loc. d mm	Int. Diam. D mm
2990001300	8006 P	25÷50	+	12,5	19
2990001400	8006 N	25÷50	-	12,5	17
2990001500	8007 P	50÷70	+	12,5	19
2990001600	8007 N	50÷70	-	12,5	17

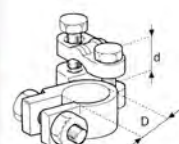

- Brass casting heavy type for forklifts and earthmoving.
- Possibility of reversing the cable fixing plate and then to block cable section also small.

Code	Desc.	For cables sect. mm <sup>2</sup>	Polarity	Ø cable loc. d mm	Int. Diam. D mm
2990000410	80 P	0-70	+	12,5	19
299 00 00420	90 N	0-70	-	12,5	17

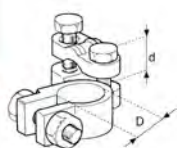

- Brass painted red. positive

Code	Desc.	For cables sect. mm <sup>2</sup>	Polarity	Ø cable loc. d mm	Int. Diam. D mm
2990004700	5014 P	16÷35	+	12,5	19

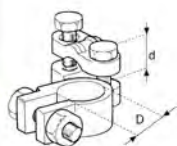

- Brass painted blue. negative

Code	Desc.	For cables sect. mm <sup>2</sup>	Polarity	Ø cable loc. d mm	Int. Diam. D mm
2990004800	5015 N	16÷35	-	12,5	17



- Brass casting

Code	Desc.	Polarity	Diameter d mm	Int. Diam. D mm
2990005100	5027 P	+	M 10	19
2990005110	5028 N	-	M 8	17



- Zinc-plated brass. For boating.

Code	Desc.	Polarity	Diameter d mm	Int. Diam. D mm
2990001100	5808 P	+	M 10	19
2990001200	5809 N	-	M 8	17



- ottone verniciato rosso. positivo

Code	Desc.	Polarity	Diameter d mm	Int. Diam. D mm
2990004300	5010 P	+	M 10	19



- Brass painted blue. Negative.

Code	Desc.	Polarity	Diameter d mm	Int. Diam. D mm
2990004400	5011 N	-	M 8	17

3

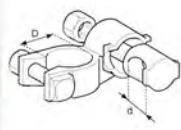

- Brass

Code	Desc.	Cable sec. mm <sup>2</sup>	Polarity	d mm	D mm
2990003400	5001 P	10-25	+	9,5	19
2990003500	5002 N	10-25	-	9,5	17
2990003600	5003 P	35-50	+	13	19
2990003700	5004 N	35-50	-	13	17



- Clamps for French cars

Code	Desc.	Polarity	Diametro polo d mm	Color
2990001900	620	+	19	RED
2990002000	621	-	17	GREEN



- Terminals for agricultural giants
- Raw brass

Code	Desc.	Polarity	Int. Diam. D mm	For cables sect. mm <sup>2</sup>
2990005130	5013	+	19	70
2990005140	5014	-	17	70



- Brass casting.
- Stralis heavy model type.
- With central screw M12 and two side M8.

Code	Desc.	Polarity	Int. Diam. D mm	Screws attachment
2990005300	5034P	+	19	M8+M12+M8



- Brass casting
- Heavy model type stralis
- With central screw m10 and two side by m8
- Only the positive terminal to the negative you can sweep across the range

Code	Desc.	Polarity	Int. Diam. D mm	Screws attachment
2990005400	5035P	+	19	M8+M10+M8

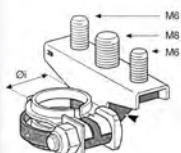

- Tinned brass.
- Last generation Fiat group.

Code	Desc.	Polarity	Int. Diam. (DI) Ø imm
2990005190	5033 P	+	19

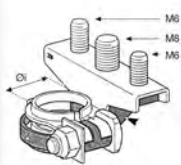

- Tinned brass.
- Last generation Fiat group.

Code	Desc.	Polarity	Int. Diam. (DI) Ø imm
2990005200	5033 N	-	17





## Probes pulls cables Perlon $\varnothing$ 4 mm



- Probes Perlon® transparent, 4 mm diameter. Compared to a traditional probe nylon it has a high tensile strength. Eyelets and interchangeable heads, pins with M4 thread. Areas of use: electric.
- No electrical conductivity.
- Supplied with: Flexible head (B) cod. 357 00 08135 and eyelet tie rod (C) code. 357 00 08140.

Code	Desc.	Length mt
3570008000	620-5	5
3570008010	620-10	10
3570008020	620-15	15
3570008030	620-20	20

## Accessories probes M4



- Flexible head with pulley (A): eases the sliding of the probe in the channels with the presence of electrical wiring harness.
- Flexible head (B). Eyelet linkage (C). Slot rod (D).
- Sock tie rod (E) allows the operator to fix the cable to probe with greater security, especially in cables coassiali. e multipolar.
- Impact-resistant plastic box (F), to safeguard and rewind the probes nylon and in particular those of fiberglass.

Code	Desc.	Characteristics	Photo
3570008130	635	FLEXIBLE HEAD WITH PULLEY	A
3570008135	636	FLEXIBLE HEAD	B
3570008140	637	EYE GUY	C
3570008145	638	HOLE TIE	D
3570008150	639	SOCK GUY WIRE DIAM 4 TO 6	E
3570008155	640	SOCK GUY WIRE DIAM 6 TO 12	E
3570008160	641	PLASTIC CONTAINER SHOCK	F

## Sonde tiracavi in fibra di vetro $\varnothing$ 3 mm



- Sonde in fibra di vetro, flessibile e robusta. buona resistenza alla trazione. Occhielli e teste intercambiabili, perni con filettatura M4.
- Rispetto ad una sonda tradizionale, permette all'operatore di fare maggiore forza nel tiro, e di diminuire notevolmente il tempo di posizionamento dei cavi nei condotti.
- Settore d'utilizzo: elettrico.
- Nessuna conducibilita' elettrica.
- Fornita con: testa flessibile guidacurve (B) cod. 357 00 08135 e occhiello tirante (C) cod. 357 00 08140.

Code	Desc.	Length mt
3570008050	625-10	10
3570008060	625-15	15
3570008070	625-20	20

## Sonde tiracavi in poliestere ø 4 mm



- Sonde a tortiglione, leggera e con un ottima resistenza alla trazione. Occhielli e teste intercambiabili, perni con filettatura M4.
- Permette all'operatore di fare maggiore forza nel tiro, e diminuire notevolmente il tempo di posizionamento dei cavi nei condotti. Consente raggi di curvatura strettissimi.
- Particolarmente adatta anche per pose in canali di notevole lunghezza.
- Settore d'utilizzo: elettrico.
- Nessuna conducibilita' elettrica.
- Fornita con: asola tirante (D) cod. 357 00 08145, testa flessibile guidacurve (B) cod. 357 00 08135, testa flessibile con carrucola (A) cod. 357 00 08130, occhio tirante (C) cod. 357 00 08140.

Code	Desc.	Length mt
3570008090	630-10	10
3570008100	630-15	15
3570008110	630-20	20

## Expandable braided sleeving



- Braiding polyester fibers self-extinguishing degree UL94-HB, operating temperature, -50 ° / + 150 ° C.
- Abrasion, aging and weathering very careful of the shoe and the sliding of the cables, the possibility of moving one or more cables through the mesh at any point.

Code	Desc.	D min. mm	DS max. mm	Color
3600002000	40/5	5	8	BLACK
3600002010	40/8	8	12	BLACK
3600002020	40/12	12	20	BLACK
3600002030	40/18	18	28	BLACK
3600002040	40/25	25	38	BLACK
3600002050	40/40	40	40	BLACK

## Spiral Polyethylene wiring



- Polyethylene spiral extremely flexible commonly used to enclose and protect bundles of electrical cables.
- Quick installation, reusable, allows the release of one or more cables at any point of the wiring.
- Maximum operating temperature: 85 ° C.
- Available in natural color and black.
- The natural color is also self-extinguishing.

Code	Desc.	D. Bundle cables mm	Ø int. mm	Ø Est. mm	Color
3600002100	50/2	2-15	2.3	3.5	NATURAL
3600002200	51/2	2-15	2.3	3.5	BLACK
3600002110	50/4	4-20	3.7	5	NATURAL
3600002210	51/4	4-20	3.7	5	BLACK
3600002120	50/7	7-40	6.5	8	NATURAL
3600002220	51/7	7-40	6.5	8	BLACK
3600002130	50/12	12-50	8.2	10	NATURAL
3600002230	51/12	12-50	8.2	10	BLACK
3600002140	50/13	13-70	10	12	NATURAL
3600002240	51/13	13-70	10	12	BLACK

## Rubbers cable sleeve



- To be used to cover the edges of a hole in the sheet.

Code	Desc.	d mm	D mm
3190000100	7	7	16
3190000200	9	9	16,5
3190000300	13	13	22
3190000400	15	15	25
3190000500	18	18	28

## Sheathing cable gland



- Guaina in PVC per passaggio cavi
- Disponibile in più diametri

Code	Desc.	D. int. mm	D. est. mm	Color
3600000100	3	3.5	4.5	BLACK
3600000200	4	4	5	BLACK
3600000300	5	5	6	NERO
3600000400	6	6	7	NERO
3600000600	8	8	9.2	NERO
3600000700	10	10	11.2	NERO
3600000800	12	12	13.5	NERO
3600000810	14	14	15.5	NERO
3600000820	16	16	17.5	NERO
3600000830	18	18	19,8	NERO

## ΘΕΡΜΟΣ/NO 1:2



- Crosslinked polyolefin heat shrink tubing, black, excellent electrical characteristics, physical and chemical properties.
- Self-extinguishing, good resistance to chemicals, weathering and moisture.
- For protection and isolation of: cable assemblies and wiring, electrical and electronic components, electrical connections, terminals and lugs, reinforcing welded.
- \* DIAM. 1-diameter before shrinking.
- \* DIAM. 2-diameter after shrinking.



Code	Desc.	Diam. 1* mm	Diam. 2* mm	Thickness mm	Conf. Mt.
4190000100	3.2	3.2	1.6	0.51	ENVELOPE 2/10
4190000200	4.8	4.8	2.4	0.52	ENVELOPE 2/10
4190000300	6.4	6.4	3.2	0.65	ENVELOPE 2/10
4190000400	9.5	9.5	3.2	0.65	ENVELOPE 2/10
4190000500	12.7	12.7	6.4	0.65	ENVELOPE 2/10
4190000600	19.1	19.1	9.5	0.77	ENVELOPE 2/10
4190000700	25.4	25.4	12.7	0.89	ENVELOPE 2/10
4190000710	38.0	38.0	19.0	0.90	ENVELOPE 5/25
4190000720	51.0	51.0	25.5	0.90	ENVELOPE 5/25
4190001480	1.6B	1.6	0.8	0.50	BOX 15
4190001490	2.4/B	2.4	1.2	0.50	BOX 15
4190001500	3.2/B	3.2	1.6	0.51	BOX 15
4190001600	4.8/B	4.8	2.4	0.52	BOX 12
4190001700	6.4/B	6.4	3.2	0.65	BOX 12
4190001800	9.5/B	9.5	4.8	0.65	BOX 10
4190001900	12.7/B	12.7	6.4	0.65	BOX 8
4190002000	19.1/B	19.1	9.5	0.77	BOX 5
4190002100	25.4/B	25.4	12.7	0.89	BOX 3

## Heat-shrin kable sheathin a double adhesive polyolefin



- Crosslinked polyolefin heat shrink tubing, black, excellent electrical characteristics, physical and chemical properties.
- Lining thermoplastic adhesive for perfect moisture resistance and high mechanical strength.
- Self-extinguishing, good resistance to chemicals, weathering and moisture.
- For protection and isolation of: cable assemblies and wiring, electrical and electronic components, electrical connections, terminals and lugs, reinforcing welded.
- Available in lengths from 1 m.
- \* DIAM. 1-diameter before shrinking
- \* DIAM. 2-diameter after shrinking

Code	Original ref.
4190000800	FIAT 91053

## Heat shrinkable sleeves assortment

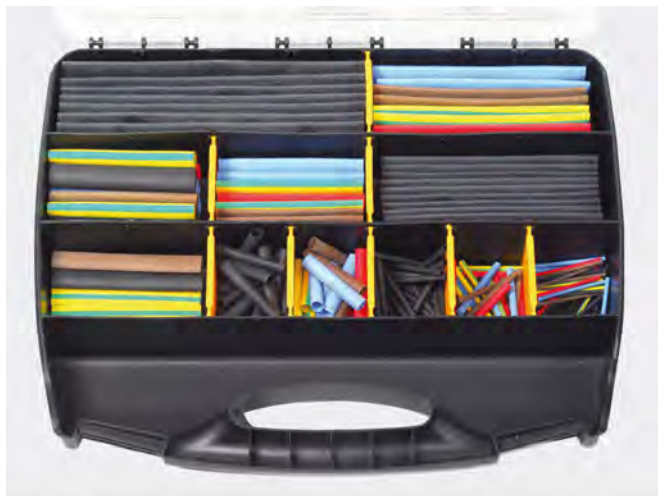

- Heat shrinkable crosslinked polyolefin thin wall.
- Excellent chemical resistance and capacity 'of electrical insulation.
- Shrink ratio 3: 1
- Operating temperature -55 ° C / 135 ° C
- Shrinkage temperature > 90 ° c self-extinguishing 224 ul, 125 ° c
- Total 170 pieces

Code	Desc.
4190003000	300 - KIT

### CONTENUTO KIT

Ø MANICOTTI (mm)	LUNGH. (mm)	COLORI	PEZZI X BOX	Ø MANICOTTI (mm)	LUNGH. (mm)	COLORI	PEZZI X BOX
1,5/05	40	NERO	10	9/3	80	GIALLO/VERDE	2
1,5/05	40	ROSSO	5	9/3	80	MARRONE	2
1,5/05	40	BLU	5	12/4	80	NERO	5
1,5/05	40	GIALLO/VERDE	5	12/4	80	ROSSO	2
1,5/05	40	MARRONE	5	12/4	80	BLU	2
3/1	40	NERO	20	12/4	80	GIALLO/VERDE	2
3/1	40	ROSSO	5	12/4	80	MARRONE	2
3/1	40	BLU	5	18/6	120	NERO	10
3/1	40	GIALLO/VERDE	5	18/6	80	ROSSO	2
3/1	40	MARRONE	5	18/6	80	BLU	2
6/2	40	NERO	20	18/6	80	GIALLO/VERDE	2
6/2	40	ROSSO	5	18/6	80	MARRONE	2
6/2	40	BLU	5	24/8	170	NERO	8
6/2	40	GIALLO/VERDE	5	24/8	120	ROSSO	2
6/2	40	MARRONE	5	24/8	120	BLU	2
9/3	80	NERO	5	24/8	120	GIALLO/VERDE	2
9/3	80	ROSSO	2	24/8	120	MARRONE	2
9/3	80	BLU	2				

## Corrugated ADR regulations



- Made of polyamide PA6
- It is not flame retardant
- Operating temperature from -40 ° to + 120 ° with peaks of 150 °
- Excellent resistance to alcohols, greases, mineral oil, diesel and petrol
- Approved by tuv for the transport of dangerous goods according to ADR, GGVS and French standards NFR 13-903
- Especially suitable for cars and commercial vehicles for the protection of electrical cables

Code	Desc.	D. int. mm	D. est. mm	Radius of curvature mm
360CO00090	7,5	6,7	10	13
360CO00100	10	9,9	13	20
360CO00200	13	12,7	15,8	35
360CO00300	17	16,6	21,2	45
360CO00400	22	21,3	25,4	50

## Accessories for corrugated

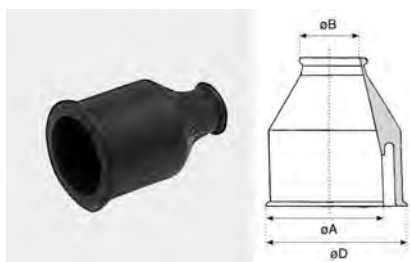

- End sleeve with neoprene sealing gland for corrugated OD. 13-17-22

Code	Desc.	B for cables mm	A mm	D mm
360CO00500	13T	4-9	10,5	22
360CO00600	17T	6-14	16	27



## Corrugated tube open



- Corrugated tube polypropylene, open type for easy insertion on the conductor also giàposizionato.
- Particularly suitable in the auto industry for the protection and insulation of electrical cables inside the engine compartment.
- TECHNICAL FEATURES:
- Materiale: polypropylene
- Operating temperature: -30 + 125 °
- Fluid resistance: good
- UV resistance: good

Code	Desc.	Color	Ø internal	Ø est.
360CO00800	6A	BLACK BLUE LINE	6	9,5
360CO00900	9A	BLACK BLUE LINE	9	11,3
360CO01000	11A	BLACK BLUE LINE	11	16,4
360CO01100	13A	BLACK BLUE LINE	13	18,4
360CO01200	16A	BLACK BLUE LINE	16	21,2
360CO01300	19A	BLACK BLUE LINE	19	24

## Electric cable hank - section 1 mm<sup>2</sup>



Code	Desc.	Meters	Color	Section	Type
3570000200	100	100	BLACK	1 mm <sup>2</sup>	H05 V-K
3570000500	103	100	RED	1 mm <sup>2</sup>	H05 V-K

- PVC power cable for unipolar
- H05 VK, norms cei 20/20 edition 2/1984 (cenelec hd 21), table UNEL 35750. Rated voltage 300/500 V
- H07 V-K, norms cei 20/20. table UNEL 35752, rated voltage 450/750

## Electric cable hank - section 1.5 to 6 mm<sup>2</sup>



Code	Desc.	Meters	Color	Section	Type
3570001100	150	100	BLACK	1,5 mm <sup>2</sup>	H07 V-K
3570001400	153	100	RED	1,5 mm <sup>2</sup>	H07 V-K
3570001900	250	100	BLACK	2,5 mm <sup>2</sup>	H07 V-K
3570002200	253	100	RED	2,5 mm <sup>2</sup>	H07 V-K
3570004200	400	100	BLACK	4 mm <sup>2</sup>	H07 V-K
3570004300	403	100	RED	4 mm <sup>2</sup>	H07 V-K
3570004310	404	100	YELLOW	4 mm <sup>2</sup>	H07 V-K
3570004400	405	100	GREY	4 mm <sup>2</sup>	H07 V-K
3570004500	406	100	BROWN	4 mm <sup>2</sup>	H07 V-K
3570004600	407	100	BLUE	4 mm <sup>2</sup>	H07 V-K
3570006480	600	100	BLACK	6 mm <sup>2</sup>	H07 V-K
3570006500	603	100	RED	6 mm <sup>2</sup>	H07 V-K
3570006505	604	100	YELLOW	6 mm <sup>2</sup>	H07 V-K
3570006510	605	100	GREY	6 mm <sup>2</sup>	H07 V-K
3570006600	606	100	BROWN	6 mm <sup>2</sup>	H07 V-K
3570006700	607	100	BLUE	6 mm <sup>2</sup>	H07 V-K

**Electric cable bicolor hank - section 1 to 1.5 mm<sup>2</sup>**

Code	Desc.	Meters	Color	Section	Type
3570002800	100/102	100	BLACK/GREEN	1 mm <sup>2</sup>	H05 V-K
3570002900	100/103	100	BLACK/RED	1 mm <sup>2</sup>	H05 V-K
3570003000	100/104	100	BLACK/YELLOW	1 mm <sup>2</sup>	H05 V-K
3570003110	100/108	100	BLACK/ORANGE	1 mm <sup>2</sup>	H05 V-K
3570003140	101/103	100	WHITE/RED	1 mm <sup>2</sup>	H05 V-K
3570003150	101/107	100	WHITE/BLUE	1 mm <sup>2</sup>	H05 V-K
3570003155	101/109	100	WHITE/LIGHT BLUE	1 mm <sup>2</sup>	H05 V-K
3570003195	102/103	100	GREEN/RED	1 mm <sup>2</sup>	H05 V-K
3570003200	102/104	100	GREEN/YELLOW	1 mm <sup>2</sup>	H05 V-K
3570003230	104/107	100	YELLOW/BLUE	1 mm <sup>2</sup>	H05 V-K
3570003250	105/107	100	GREY/BLUE	1 mm <sup>2</sup>	H05 V-K
3570003300	150/151	100	BLACK/WHITE	1,5 mm <sup>2</sup>	H07 V-K
3570003400	150/152	100	BLACK/GREEN	1,5 mm <sup>2</sup>	H07 V-K
3570003450	150/154	100	BLACK/YELLOW	1,5 mm <sup>2</sup>	H07 V-K
3570003600	152/154	100	GREEN/YELLOW	1,5 mm <sup>2</sup>	H07 V-K

**Electric cable Reel - section 0.5 to 1 mm<sup>2</sup>**

Code	Desc.	Meters	Color	Section	Type
357BO00010	500	100	BLACK	0,5 mm <sup>2</sup>	H05 V-K
357BO00015	501	100	WHITE	0,5 mm <sup>2</sup>	H05 V-K
357BO00020	502	100	GREEN	0,5 mm <sup>2</sup>	H05 V-K
357BO00025	503	100	RED	0,5 mm <sup>2</sup>	H05 V-K
357BO00030	504	100	YELLOW	0,5 mm <sup>2</sup>	H05 V-K
357BO00035	505	100	GREY	0,5 mm <sup>2</sup>	H05 V-K
357BO00040	106	100	BROWN	0,5 mm <sup>2</sup>	H05 V-K
357BO00045	107	100	BLUE	0,5 mm <sup>2</sup>	H05 V-K
357BO00050	108	100	ORANGE	0,5 mm <sup>2</sup>	H05 V-K
357BO00060	110	100	VIOLET	0,5 mm <sup>2</sup>	H05 V-K
357BO00065	111	100	PINK	0,5 mm <sup>2</sup>	H05 V-K
357BO00100	1000	100	BLACK	1 mm <sup>2</sup>	H07 V-K
357BO00200	1010	100	WHITE	1 mm <sup>2</sup>	H07 V-K
357BO00300	1020	100	GREEN	1 mm <sup>2</sup>	H07 V-K
357BO00400	1030	100	RED	1 mm <sup>2</sup>	H07 V-K
357BO00500	1040	100	YELLOW	1 mm <sup>2</sup>	H07 V-K
357BO00600	1050	100	GREY	1 mm <sup>2</sup>	H07 V-K
357BO00700	1060	100	BROWN	1 mm <sup>2</sup>	H07 V-K
357BO00800	1070	100	BLUE	1 mm <sup>2</sup>	H07 V-K
357BO00810	1080	100	ORANGE	1 mm <sup>2</sup>	H07 V-K
357BO00820	1100	100	VIOLET	1 mm <sup>2</sup>	H07 V-K
357BO00825	1110	100	PINK	1 mm <sup>2</sup>	H07 V-K

- PVC power cable for unipolar
- H05 VK, CEI 20/20 edition 2/1984 (cenelec hd 21), table UNEL 35750. voltage 300/500 V
- H07 V-K, according to CEI 20/20. table UNEL 35752, rated voltage 450/750

## Electric cable Reel - section 1.5 to 6 mm<sup>2</sup>



Code	Desc.	Meters	Color	Section	Type
357BO00900	1500	100	BLACK	1,5 mm <sup>2</sup>	H07 V-K
357BO01000	1510	100	WHITE	1,5 mm <sup>2</sup>	H07 V-K
357BO01100	1520	100	GREEN	1,5 mm <sup>2</sup>	H07 V-K
357BO01200	1530	100	RED	1,5 mm <sup>2</sup>	H07 V-K
357BO01300	1540	100	YELLOW	1,5 mm <sup>2</sup>	H07 V-K
357BO01400	1550	100	GREY	1,5 mm <sup>2</sup>	H07 V-K
357BO01500	1560	100	BROWN	1,5 mm <sup>2</sup>	H07 V-K
357BO01600	1570	100	BLUE	1,5 mm <sup>2</sup>	H07 V-K
357BO01610	1580	100	ORANGE	1,5 mm <sup>2</sup>	H07 V-K
357BO01620	1600	100	VIOLET	1,5 mm <sup>2</sup>	H07 V-K
357BO01630	2000	50	BLACK	2 mm <sup>2</sup>	H07 V-K
357BO01635	2010	50	WHITE	2 mm <sup>2</sup>	H07 V-K
357BO01640	2020	50	GREEN	2 mm <sup>2</sup>	H07 V-K
357BO01700	2500	50	BLACK	2,5 mm <sup>2</sup>	H07 V-K
357BO01800	2510	50	WHITE	2,5 mm <sup>2</sup>	H07 V-K
357BO01900	2520	50	GREEN	2,5 mm <sup>2</sup>	H07 V-K
357BO02000	2530	50	RED	2,5 mm <sup>2</sup>	H07 V-K
357BO02100	2540	50	YELLOW	2,5 mm <sup>2</sup>	H07 V-K
357BO02200	2550	50	GREY	2,5 mm <sup>2</sup>	H07 V-K
357BO02300	2560	50	BROWN	2,5 mm <sup>2</sup>	H07 V-K
357BO02400	2570	50	BLUE	2,5 mm <sup>2</sup>	H07 V-K
357BO02405	2580	50	ORANGE	2,5 mm <sup>2</sup>	H07 V-K
357BO02415	2600	50	VIOLET	2,5 mm <sup>2</sup>	H07 V-K
357BO03900	3000	50	BLACK	3 mm <sup>2</sup>	H07 V-K
357BO03920	3020	50	GREEN	3 mm <sup>2</sup>	H07 V-K
357BO03930	3030	50	RED	3 mm <sup>2</sup>	H07 V-K
357BO03940	3040	50	YELLOW	3 mm <sup>2</sup>	H07 V-K
357BO04100	4000	25	BLACK	4 mm <sup>2</sup>	H07 V-K
357BO04110	4010	25	WHITE	4 mm <sup>2</sup>	H07 V-K
357BO04120	4020	25	GREEN	4 mm <sup>2</sup>	H07 V-K
357BO04130	4030	25	RED	4 mm <sup>2</sup>	H07 V-K
357BO04160	4060	25	BROWN	4 mm <sup>2</sup>	H07 V-K
357BO04170	4070	25	BLUE	4 mm <sup>2</sup>	H07 V-K
357BO04300	6000	25	BLACK	6 mm <sup>2</sup>	H07 V-K
357BO04310	6010	25	WHITE	6 mm <sup>2</sup>	H07 V-K
357BO04320	6020	25	GREEN	6 mm <sup>2</sup>	H07 V-K
357BO04330	6030	25	RED	6 mm <sup>2</sup>	H07 V-K
357BO04350	6050	25	GREY	6 mm <sup>2</sup>	H07 V-K
357BO04360	6060	25	BROWN	6 mm <sup>2</sup>	H07 V-K
357BO04370	6070	25	BLUE	6 mm <sup>2</sup>	H07 V-K



## Electric cable bicolor Reel - section 1 to 1.5 mm<sup>2</sup>



Code	Desc.	Meters	Color	Section	Type
357B002500	1000/1010	100	BLACK/WHITE	1 mm <sup>2</sup>	H05 V-K
357B002600	1000/1020	100	BLACK/GREEN	1 mm <sup>2</sup>	H05 V-K
357B002700	1000/1030	100	BLACK/RED	1 mm <sup>2</sup>	H05 V-K
357B002800	1000/1040	100	BLACK/YELLOW	1 mm <sup>2</sup>	H05 V-K
357B002900	1000/1070	100	BLACK/BLUE	1 mm <sup>2</sup>	H05 V-K
357B003300	1500/1530	100	BLACK/RED	1,5 mm <sup>2</sup>	H07 V-K
357B003400	1500/1540	100	BLACK/YELLOW	1,5 mm <sup>2</sup>	H07 V-K
357B003500	1500/1570	100	BLACK/BLUE	1,5 mm <sup>2</sup>	H07 V-K

## Straps speakers

3

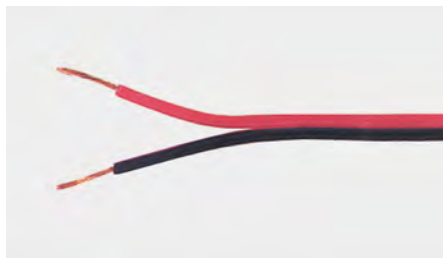

- Cable tangle.

Code	Desc.	Meters	Section	Color
3570004700	2050	100	2x0.50	RED / BLACK
3570004690	2040	100	2x1	RED / BLACK
3570004692	2042	100	2x1,5	RED / BLACK
3570004694	2044	100	2x2,5	RED / BLACK

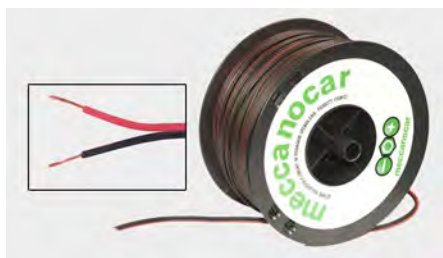

- Cable reel

Code	Desc.	Meters	Section	Color
357B003700	20500	100	2x0.50	RED / BLACK



- Cable coil

Code	Desc.	Meters	Section	Color
3570004800	2010	100	2x1	BLUE / BLACK

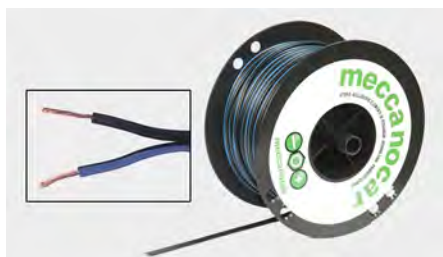

- Cable reel.

Code	Desc.	Meters	Section	Color
357B003800	20100	50	2x1	BLUE / BLACK

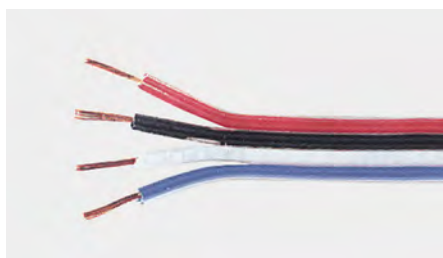

- Cable coil

Code	Desc.	Meters	Section	Color
3570004810	4050	100	4x0.50	4 COLOURS

## Rubber cable Multiple

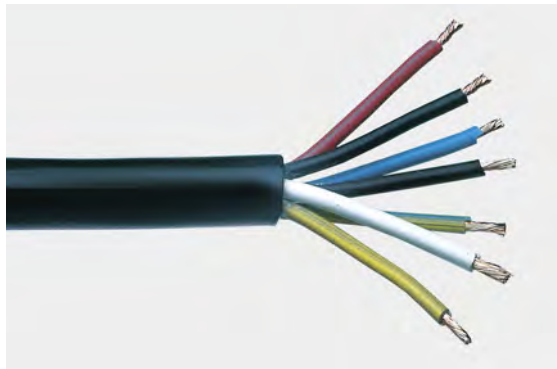

- Multiple cable with PVC black

Code	Desc.	N. Cables	Cable sec. mm <sup>2</sup>
3570000150	76-2X1	2	1
3570000152	76-3X1	3	1
3570000153	76-4X1	4	1
3570000154	76-5X1	5	1
3570000155	76-6X1	6	1
3570000156	76-7X1	7	1
3570000151	76-2X1.5	2	1.5
3570000181	76-3X1.5	3	1.5
3570000186	76-6X1+1X2.5	7	1+2.5
3570000188	76-6X1.5+1X2.5	7	1.5+2.5

## Rubber cable under "ADR"

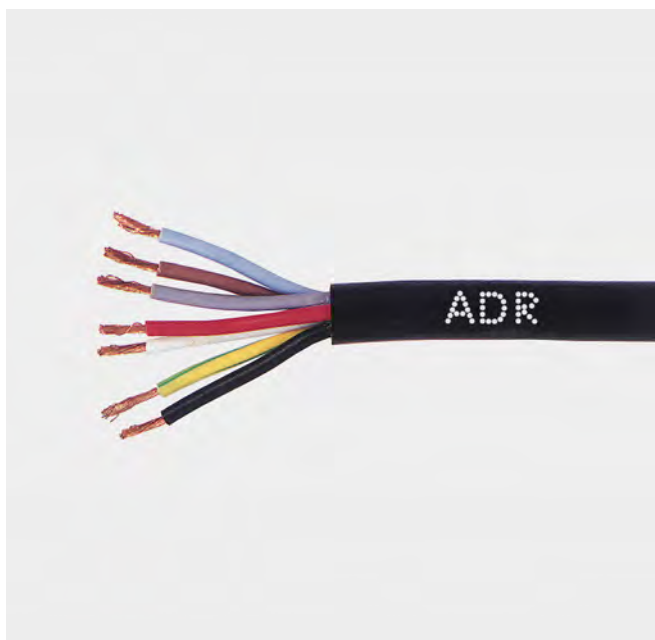

- Wheeled multiple cables particularly suitable for the connection of the electrical installation of all trailers and semi-trailers constructed, in particular, for the transport of dangerous goods in accordance with standard ADR.
- Insulation of the conductors and intermediate sheath PVC, polyurethane outer sheath, black color.
- These cables are resistant to UV radiation and low temperatures, weathering, oil and chemicals.
- Thanks to the coating while the cables have an excellent resistance to wear and abrasion, as well as a considerable resistance to attack microbotic and hydrolysis.
- Manufactured according to the latest versions of the international standards ISO 4141 and ISO 6722.
- Temperature range -40 ° C / + 85 ° C

Code	Desc.	Nr. and sect. cables	D. est. mm	Possible applications
3570000194	77-2X1	2X1 mmq	6.5	SIDE MARKER + MISCELLANEOUS
3570000196	77-6X1+1X2	6X1 mmq+1X2 mmq	9.8	7 POLES - MISCELLANEOUS



## Piattina rettangolare a norme ADR e accessori



- Indicati per impianti luci e trasformazioni



Code	Description
3570000198	78-2x1,5 mm <sup>2</sup>
4280008065	2855 clip x click-in
4280008070	2858 cappuccio di protezione
4280008072	2860 rubacorrente per piattina ADR

## Rubber cable power



- Multiple cable insulated with neoprene exterior color black, extremely flexible and resistant to cutting and abrasion
- Recommended for extension cords and cables for power tools

Code	Desc.	N. Cables	cabl. sec. mm <sup>2</sup>
3570007100	612-3X1.5	3	1.5
3570007200	612-3X2.5	3	2.5
3570007400	612-4X2.5	4	2.5

## Flexible cable for batteries



- Battery cable with PVC coating.
- Quality mark imq.

Code	Desc.	cabl. sec. mm <sup>2</sup>	D. est. mm	Color
3610000030	10 NE	10	7	BLACK
3610000100	16 NE	16	8	BLACK
3610000105	16 RO	16	8	RED
3610000115	25 NE	25	10	BLACK
3610000116	25 RO	25	10	RED
3610000120	35 NE	35	10.5	BLACK
3610000121	35 RO	35	10.5	RED
3610000125	50 NE	50	15	BLACK
3610000127	50 RO	50	15	RED
3610000130	70 NE	70	16	BLACK
3610000131	70 RO	70	16	RED

## Fil service Bobbin empty



Code	Desc.	Ø mm
357B100100	16000	160

## Fil service Wall

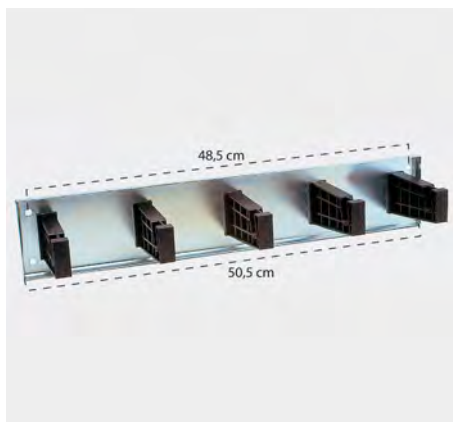

- The Fil service Wall is available in 4 coils. Easy to fix on the wall with expansion bolts once set allows a quick selection of the necessary cable and therefore a considerable saving of time. The fasteners that hold the coils are arranged to hold the spool by sliding it gently, smoothly.

Code	Desc.	Content
357B400200	14001	4 EMPTY

## Fil service Wall full



- Composition: the common service to 4 people consists of one coil wire  $\varnothing$  1 mm<sup>2</sup>, 1 coil wire diameter 1.5 mm<sup>2</sup>, 1 coil wire 2.5 mm<sup>2</sup>, 1 reel strip r / n 2x0,50 mm<sup>2</sup>.

Code	Desc.	Content
357B400100	14000	4 COMPLETE

## Cable candles



- Flexible cable for candles, copper conductor, PVC insulation.

Code	Desc.	Color	D. est. mm
3570000050	75	BLACK	7

## Shielded cable for candles



- Flexible cable for candles, copper conductor, insulating anti disorders screened black.

Code	Desc.	D. est. mm
3570000100	76/1	7

## Attack candle motorbike



Code	Desc.	Section	Ø cavo	Material	Color
3170021740	52371	6,3	7	RUBBER EPDM	BLUE

## Terminals for candels and coil



Code	Desc.
3170021765	52376
3170021770	52377

3

## Plugs Industrial 220-380 V IP44 and IP67



- Industrial plugs flying with self-extinguishing polymer housing, nickel-plated brass pins, degree of protection according to IEC 529 and IEC 60529: IP44 and IP67.
- Models available for voltages of 220 and 380 V AC.
- Rated currents of 16A.
- Degree of shock protection according to CEI EN 50102: IK08.
- The nickel contacts prevents consumption and oxidation during the most demanding use.
- For various uses, both within companies and on construction sites.

Code	Desc.	Voltage Volt	Electrical current nominal	Degree of protection
3550000050	1/1	220	16 A	IP44
3550000100	1/2	220	16 A	IP67
3550000250	2/1	380	16 A	IP44
3550000300	2/2	380	16 A	IP67

## Took industrial furniture 220-380 V IP44 and IP67



- Industrial sockets flying enveloped in self-extinguishing polymer, cells nickel-plated brass pins and stainless steel springs, protection according to IEC 529 and IEC 60529: IP44 and IP67.
- Models available for voltages of 220 and 380 V AC Rated currents of 16A.
- Degree of shock protection according to CEI EN 50102: IK08.
- The nickel contacts prevents consumption and oxidation during the most demanding use.
- For various uses, both within companies and on construction sites.

Code	Desc.	Voltage Volt	Electrical current nominal	Degree of protection
3550000450	3/1	220	16 A	IP44
3550000500	3/2	220	16 A	IP67
3550000650	4/1	380	16 A	IP44
3550000700	4/2	380	16 A	IP67

## Adattatore con spina CEE-schuko



- Adapters built for use in all areas in compliance with CEI 23-12 and EN 60309-1 / 2.
- Made of self-extinguishing thermoplastic material resistant to heat and fire according to IEC 695- 2-1 at 850 ° C.
- High impact resistance even at low temperatures.
- Important: the use and allowed only for temporary mobile installations. For fixed installations and provide for an adequate permanent electrical system.

Code	Description	Voltage (V)
3550001700	12-Adattatore CEE-SCHUKO	200-250V

## Adattatore con spina CEE-bipasso



- Alveoli attivi protetti da contatti accidentali
- Protezione IP44
- 16A 250V
- Conformi norma IEC309

Code	Description	Voltage (V)
3550001750	13-Adattatore CEE-BIPASSO	200-250V

## Adattatore con spina



- Alveoli attivi protetti da contatti accidentali
- Protezione IP44
- 16A 250V
- Conformi norma IEC309

Code	Description	Voltage (V)
3550005060	Adattatore CEE + SPINA 16A 2P+T	200-250V

## Adattatore con spina schuko



- Alveoli attivi protetti da contatti accidentali
- Protezione IP44
- 16A 250V
- Conformi norma IEC309

Code	Description	Voltage (V)
3550005200	71-Adattatore CEE + SPINA SCHUKO	200-250V

3

## Adattatore con spina CEE 16A -3P+N+T - bipasso



- Alveoli attivi protetti da contatti accidentali
- Protezione IP44
- 16A 250V
- Conformi norma IEC309
- Can only be used on 5-pin sockets

Code	Description	Voltage (V)
3550005210	72-Adattatore CEE + BIPASSO	250-415V

## Adattatori 2 uscite



- Alveoli attivi protetti da contatti accidentali
- Protezione IP44
- 16A 250V
- Conformi norma IEC309
- **Spina da 16A 2P+T**

Code	Description	Voltage (V)	Photo
3550005220	73-Adattatore 2 prese CEE IP44 2P+T	200-250V	1
3550005230	74-Adattatore 2 prese CEE IP44 3P+T	380-415V	2

## Adattatori 3 uscite



- Alveoli attivi protetti da contatti accidentali
- Protezione IP44
- 16A 250V
- Conformi norma IEC309
- **Spina da 16A 2P+T**

Code	Description	Voltage (V)	Photo
3550005240	75-Adattatore 3 prese CEE IP44 2P+T	200-250V	1
3550005250	76-Adattatore 3 prese CEE IP44 3P+T	380-415V	2

## Adattatori 2 uscite



- Alveoli attivi protetti da contatti accidentali
- Protezione IP44
- 16A 250V
- Conformi norma IEC309
- **Spina da 16A 2P+T**

Code	Description	Voltage (V)	Photo
3550005260	77-Presa CEE + 1 Schuko/bipasso 10/16A	200-250V	1
3550005270	78-Presa CEE + 2 Prese bipasso 10/16A	200-250V	2



## Adattatori 2 ucite



- Alveoli attivi protetti da contatti accidentali
- Protezione IP44
- 16A 250V
- Conformi norma IEC309
- **Spina da 16A 3P+N+T**
- Can only be used on 5-pin sockets

Code	Description	Voltage (V)
3550005280	79 -1 Presa 3P+T + 1 Presa 2P+T IP44	380-415V

## Sockets and plugs for low voltage



- Identification color: purple.
- For low voltage - 25V max.
- 16A - 2 poles.
- Ideal for connecting luminaires and network extensions.



Code	Description	Degree of protection	Photo
3550001500	9-TRAP	IP44	1
3550001550	10-TRAP	IP67	2
3550001510	9/1-PLUG	IP44	3

## Spine diritte con passacavo



- Corpo in materiale termoplastico
- Alveoli e spinotti protetti da contatti accidentali
- Viti di chiusura del bloccacavo e del corpo a taglio/croce
- Protezione IP20
- Conformi norma CEI 23-50-II Ed.2007

Code	Description	Color	Photo
3550005070	58-Spina diritta 2P+T 10A 250V	nero	1
3550005080	59- Spina diritta 2P+T 16A 250V	nero	2

## Spine piatte a squadra con passacavo

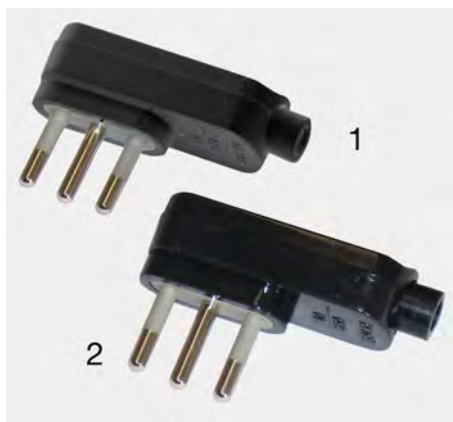

- Corpo in materiale termoplastico
- Alveoli e spinotti protetti da contatti accidentali
- Viti di chiusura del bloccacavo e del corpo a taglio/croce
- Protezione IP20
- Conformi norma CEI 23-50-II Ed.2007

Code	Description	Color	Photo
3550005090	60-Spina piatta 2P+T 10A 250V	nero	1
3550005100	61- Spina piatta 2P+T 16A 250V	nero	2

## Spine schuko



- Corpo in materiale termoplastico
- Alveoli e spinotti protetti da contatti accidentali
- Viti di chiusura del bloccacavo e del corpo a taglio/croce
- Protezione IP20
- Conformi norma CEI 23-50-II Ed.2007
- **Ingresso cavo verticale**

Code	Description	Color
3550005110	62-Spina schuko 2P+T 16A 250V	bianco

## Prese schuko/bipasso



- Corpo in materiale termoplastico
- Alveoli e spinotti protetti da contatti accidentali
- Viti di chiusura del bloccacavo e del corpo a taglio/croce
- Protezione IP20
- Conformi norma CEI 23-50-II Ed.2007

Code	Description	Color	Photo
3550005120	63-Prese schuko 2P+T 10/16A 250V	bianco	1
3550005130	64- Prese schuko 2P+T 10/16A 250V	nero	2

## Prese con passacavo



- Corpo in materiale termoplastico
- Alveoli e spinotti protetti da contatti accidentali
- Viti di chiusura del bloccacavo e del corpo a taglio/croce
- Protezione IP20
- Conformi norma CEI 23-50-II Ed.2007

Code	Description	Color
3550005140	65-Prese 2P+T Bipasso 10/16A 250V	nero

## Adattatore triplo



- Corpo in materiale termoplastico
- Alveoli e spinotti protetti da contatti accidentali
- Protezione IP20
- Massima potenza prelevabile: 1500W
- Conformi norma CEI 23-50-II Ed.2007 e CEI 23-57-II Ed.2007

Code	Description	Color	Photo
3550005150	66-Adattatore triplo 10A 2P + T 250V	nero	1
3550005160	67-Adattatore triplo 16A 2P + T 250V	nero	2

## Adattatore triplo con schuko



- Corpo in materiale termoplastico
- Alveoli e spinotti protetti da contatti accidentali
- Protezione IP20
- Massima potenza prelevabile: 1500W
- Conformi norma CEI 23-50-II Ed.2007 e CEI 23-57-II Ed.2007

Code	Description	Color	Photo
3550005170	68-Adattatore triplo 10A 2P + T 250V 2 Uscite + Schuko	nero	1
3550005180	69-Adattatore triplo 16A 2P + T 250V 2 Uscite bipasso + Scuko	nero	2

## Adapters schuko - 250V

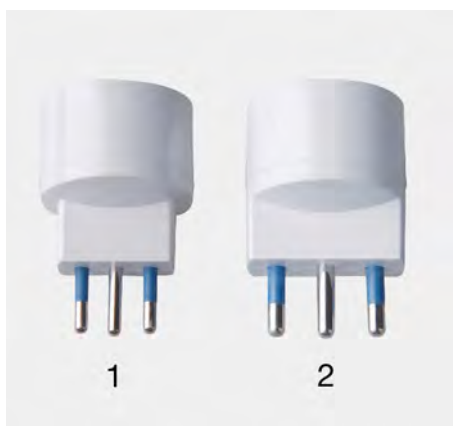

- Corpo in materiale termoplastico
- Alveoli e spinotti protetti da contatti accidentali
- Protezione IP20
- Massima potenza prelevabile: 1500W
- Conformi norma CEI 23-50-II Ed.2007 e CEI 23-57-II Ed.2007

Code	Description	Color	Photo
3550001810	14-Adattatore 10A 2P + T 250V	bianco	1
3550001820	15-Adattatore 16A 2P + T 250V	bianco	2

## Adattatore triplo con interruttore luminoso e 2 USB



- Corpo in materiale termoplastico
- Alveoli e spinotti protetti da contatti accidentali
- Protezione IP20
- Massima potenza prelevabile: 1500W
- Conformi norma CEI 23-50-II Ed.2007 e CEI 23-57-II Ed.2007
- **Spina 2P+T 16A 250V**
- **2 uscite bipasso + 1 Schuko/bipasso+2 USB**

Code	Description	Color
3550005190	70-Adattatore Triplo +2 USB	bianco

## Multiprese con interruttore



- White color.
- Wired 3G - 1.5 VDE 0281-5.
- 2P - T. 16A.
- Socket universal outputs shuko + bivalent.

Code	Desc.	N° sockets
3550002200	21	4X16A
3550002250	22	5X16A
3550002300	23	7X16A

## Connections mass motor



- Braid and copper terminals without insulation.

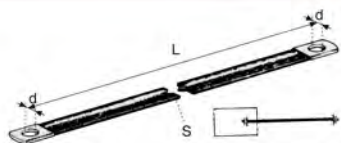

Code	Desc.	SEZ. mm <sup>2</sup>	D mm	L mm
3590000100	150	16	8,4	140
3590000200	250	25	10,4	250
3590000300	350	25	12,5	350

## Cables for connecting batteries



- LEGEND:
- ø 19 positive battery
- ø 17 negative battery
- body earth
- starter
- battery

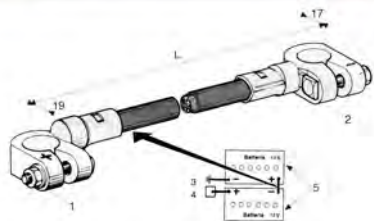

Code	Desc.	Polarity	Cable sec. mm <sup>2</sup>	L mm
3610000160	4333	+ -	35	200
3610000290	4334/4	+ -	50	400
3610000300	4335	+ -	50	500

## Clamps for cable battery charger 40A

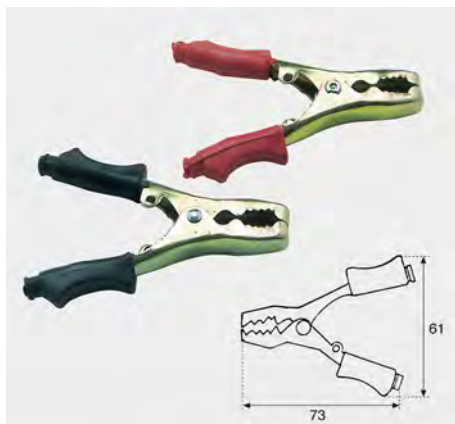

Code	Desc.	in Max	Cable sec. mm <sup>2</sup>	Color
3620000600	A-40A	40 A	6÷10	RED
3620000700	AB-40A	40 A	6÷10	BLACK

## Clamps for cable charger 120A



Code	Desc.	in Max	Cable sec. mm <sup>2</sup>	Color
3620000100	A-120	120 A	10÷25	RED
3620000200	AB-120	120 A	10÷25	BLACK

## Clamps for cable battery charger 400A



- For high steps of rated current (In).

Code	Desc.	in Max	Cable sec. mm <sup>2</sup>	Color
3620000400	A-400	300 A	35	RED
3620000500	AB-400	300 A	35	BLACK

## Pair cable with clamps for connecting batteries and start emergency



Code	Desc.	in Max	Cable sec. mm <sup>2</sup>	Length mm
3620000300	ABC	120 A	16	2500
3620000800	ABCD	300 A	35	3500
3620000810	ABCD/50	400 A	50	5000



# TABELLA LAMPADE AUTO

3

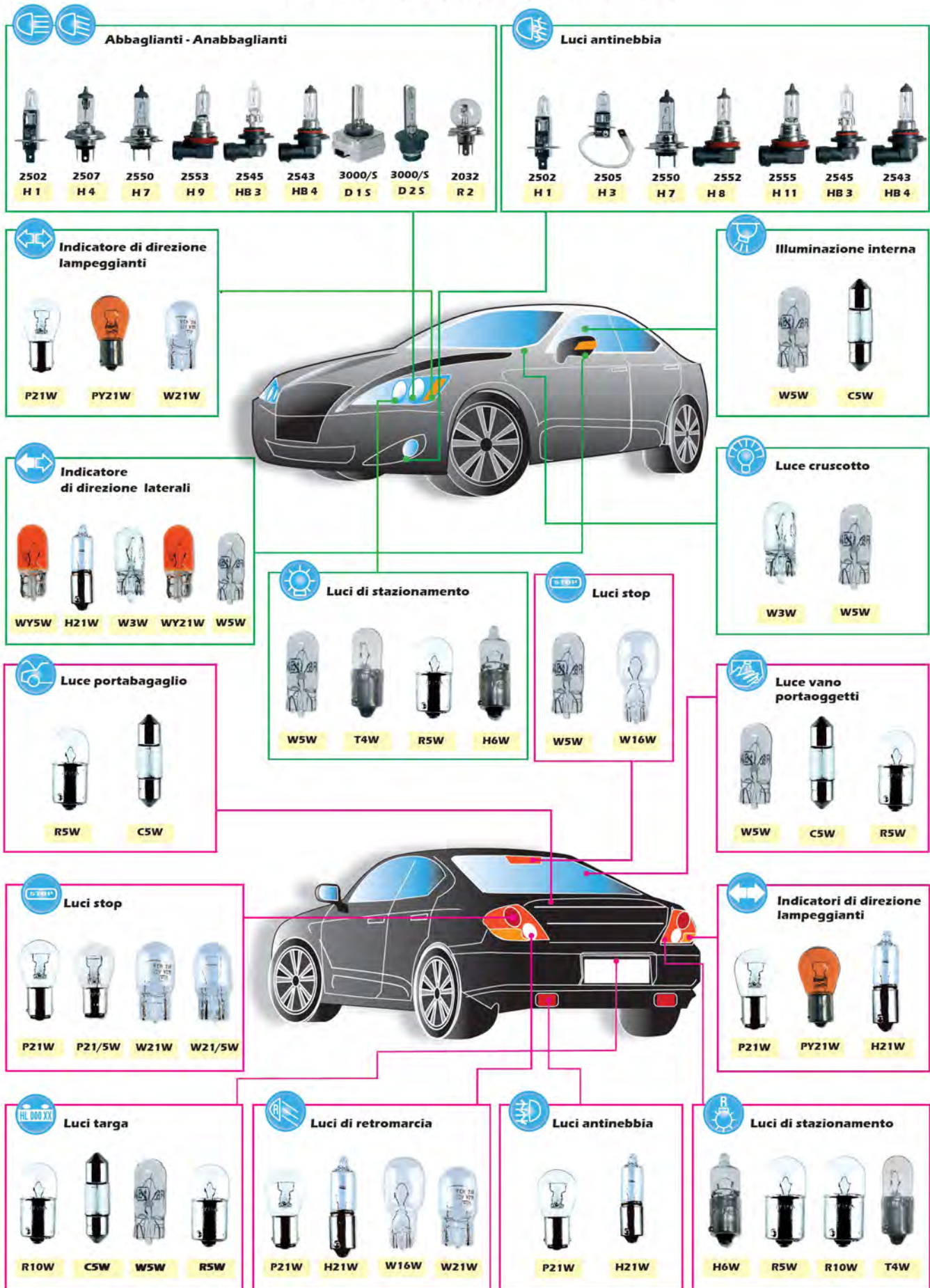

## FAMIGLIA 456 00

H1 - 2502		H3 - 2505		H4 - 2507	
456 00 08300	ALOGENA	456 00 08500	ALOGENA	456 00 08700	ALOGENA
456 00 08302	ALOGENA LONG LIFE	456 00 08510	PLASMA	456 00 08702	ALOGENA LONG LIFE
456 00 08310	PLASMA	456 00 08520	XENON	456 00 08810	PLASMA
456 00 08320	XENON			456 00 08820	XENON
H5 - 2517		H7 - 2550		H8 - 2552	
456 00 09200	ALOGENA	456 00 09610	ALOGENA	456 00 09643	ALOGENA LONG LIFE
		456 00 09612	ALOGENA LONG LIFE	456 00 09644	XENON
		456 00 09620	PLASMA		
		456 00 09630	XENON		
		456 00 10460	4 SEASON		
H11 - 2555		HB4 - 2543		H9 - 2553	
456 00 09649	ALOGENA LONG LIFE	456 00 09450	ALOGENA	456 00 09647	ALOGENA LONG LIFE
456 00 09648	XENON	456 00 09451	PLASMA	456 00 09646	XENON
		456 00 09452	XENON		
HB3 - 2545		D2R - 3000/5		D1R - 3000/R	
456 00 09460	ALOGENA	456 00 10480	XENON	456 00 10500	XENON
456 00 09462	XENON				
D15 - 3000/5		H21W		D2S - 3000/5	
456 00 10490	XENON	456 00 09430	XENON	456 00 10470	XENON
C5W		R2 - 2032		P21/5W	
456 00 02900	12V-3W-8X38 SILURO	456 00 01800	ASIMETRICA	456 00 00600	12V-5/21W-BAY15D2FIL.
456 00 03000	12V-5W-8X38 SILURO				
456 00 03300	12V-5W-SV8.5-8 SILURO				
456 00 03400	12V-10W-SV8.5-8 SILURO				
456 00 03800	12V-15W-SV8.5-8 SILURO				
456 00 03900	12V-20W-SV8.5-8 SILURO				
456 00 06700	12V-3W-SV7-8 SILURO				
456 00 08211	12V-5W-SV8.5-8 SILURO				
456 00 08212	12V-10W-SV8.5-8 SILURO				
W16W		W3W		T4W	
456 00 08237	12V-16W-W2,1X9,5D-T15	456 00 07800	12V-3W-T10 ZOCCOLO VETRO	456 00 02200	12V-3W-BA9S
				456 00 06300	12V-4W-BA9S
				456 00 07500	12V-5W-BA9S
W21W		W5W		WY5W	
456 00 08235	12V-21W-W3X16D-T20	456 00 08206	12V-5W-T10 ZOCCOLO VETRO	456 00 08204	GIALLA-12V-5W-T10 ZOCC.VE
				456 00 08205	12V-5W-T10 ZOCCOLO VETRO BLUE
W21/5W		R5W		H6W	
456 00 08240	12V-21/5W-W3X15D-T20	456 00 00900	6V-5W-BA15S SFERICA	456 00 09437	12V-6W-BAX9S-H6 ALOGENA
WY21W		RY10W		R10W	
456 00 08236	12V-21W-3X16D-T20-A	456 00 10213	12V-10WBAU15S AMBER	456 00 005900	12V-10W-BA15S
W2W		R21W			
456 00 07737	12V-2W-T10 ZOCCOLO VETRO	456 00 08265	12V-21W-BAU15S 1 FILAMENTI		



# TABELLA LAMPADE CAMION

3

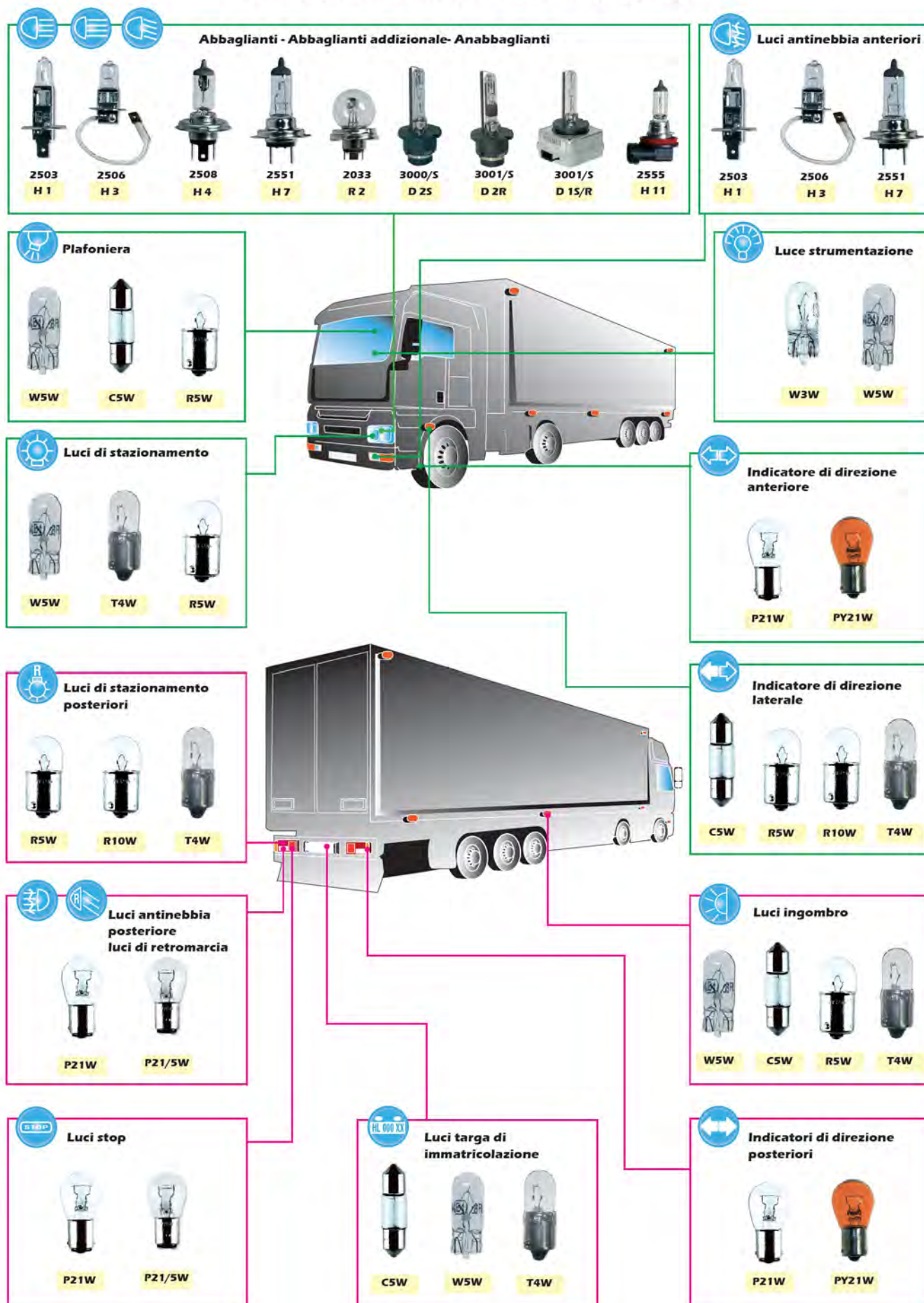

## FAMIGLIA 456 00

H1 - 2503	
456 00 08400	ALOGENA
456 00 08401	ALOGENA LONG LIFE
456 00 08402	PLASMA

H3 - 2506	
456 00 08600	ALOGENA

H4 - 2508	
456 00 08900	ALOGENA
456 00 08901	ALOGENA LONG LIFE
456 00 08902	XENON

H5 - 2518	
456 00 09400	ALOGENA

H7 - 2551	
456 00 09640	ALOGENA
456 00 09641	ALOGENA LONG LIFE
456 00 09642	XENON

H11 - 2565	
456 00 09808	XENON

D1S - 3000	
456 00 10490	XENON

D2R - 3001	
456 00 10480	XENON

D1R - 3000	
456 00 10500	XENON

CSW	
456 00 03500	24V-5W-SV8.5-8 SILURO
456 00 06900	24V-10W-SV8.8-8 SILURO
456 00 08213	24V-5W-SV8.5-8 SILURO

R10W	
456 00 06000	24V-100W-BA15S SFERICA

D2S - 3001	
456 00 10470	XENON

P21W	
456 00 00300	24V-21W-BA15S 1 FIL.
456 00 00305	HD-24V-21W-BA15S
456 00 00310	24V-15W-BA15S 1 FIL.
456 00 07600	24V-25W-BA15S 1 FIL.

R2	
456 00 02000	24V-50/45W-P45T ASIMMETRI

P21/5W	
456 00 00700	24V-5/21W-BAY15D 2 FIL.

R5W	
456 00 01000	24V-5W-BA15S SFERICA
456 00 01005	HD-24V5W-BA15S

T4W	
456 00 02300	24V-3W-BA9S TUBOLARI
456 00 06400	24V-4W.BA9S TUBOLARE

W3W	
456 00 07900	24V-3W-T10 ZOC. VETRO
456 00 08207	24V-5W-T10 ZOC. VETRO

PY21W	
456 00 010215	24V-21W/W-BA15S GIALLA

W5W	
456 00 08207	24V-5W T10 ZOCCOLO VETRO



# TABELLA LAMPADE MOTO

3





## FAMIGLIA 456 00

W21/5W	
456 00 08240	12V-5/21W3X16D-T20

H7 - 2550	
456 00 09610	ALOGENA
456 00 09612	ALOGENA LONG LIFE
456 00 09620	PLASMA
456 00 09630	XENON
456 00 10460	4 SEASON

H4 - 2507	
456 00 08700	ALOGENA
456 00 08702	ALOGENA LONG LIFE
456 00 08810	PLASMA
456 00 08820	XENON

W21W	
456 00 08235	12V-21W-W3X16D-T20

PY21W	
456 00 10200	12V-21W-BAU15S GIALLA
456 00 10213	12V-10W BAU15S AMBER

P21/5W	
456 00 00600	12V-5/21W-BAY15D 2FIL.

HS1 - 2590	
456 00 09840	XENON

W3W	
456 00 07800	12V-3W-T10 ZOC.VETRO

P21W	
456 00 00200	12V-21W-BA15S
456 00 00210	12V-15W-BA15S-2 FIL.

RSW	
456 00 00800	6V-5W-BA15S SFERICA
456 00 00900	12V-5W-BA15S SFERICA

T4W	
456 00 02200	12V-3W-BA9S
456 00 06200	6V-4W-BA9S
456 00 06300	12V-4W-BA9S
456 00 07400	6V-5W-BA9S
456 00 07500	12V-5W-BA9S

WY5W	
456 00 08204	GIALLA-12V-5W-T10 ZOCC.
456 00 08205	12V-5W-T10 ZOCCOLO VETRO BLUE

WSW	
456 00 08206	12V-5W-T10 ZOC.VETRO

WY21W	
456 00 08236	12V-21W-W3X16D-T20-AMBER

RY10W	
456 00 10213	12V-10W BAU15S AMBER

H6W	
456 00 09437	12V-6W-BAX9S-H6 ALOGENA

3

## Lampade per proiettori

Le lampade per proiettori meccanocar sono studiate e realizzate rispettando tutte le normative vigenti, omologate, e testate per ottenere la massima resa luminosa con la massima durata. Sono disponibili negli attacchi standard adottati dalle case automobilistiche, in versione alogena, plasma con luce bianca per l'uso in condizioni atmosferiche avverse, effetto Xenon per la miglior visibilita' e comfort d'uso, four season per una visibilita' ottimale in tutte le condizioni d'esercizio. Ad esse si affiancano i ricambi per le luci a scarica capacitiva Xenon montate in primo impianto sulle vetture di prestigio. La gamma meccanocar e' affiancata dalle lampade osram, marchio di prestigio per chi desidera la griffe leader. Ogni tipo di lampada e' disponibile nelle versioni a 12 e 24 volts, per motocicli, automezzi leggeri e pesanti.

### Attacchi lampade per proiettori

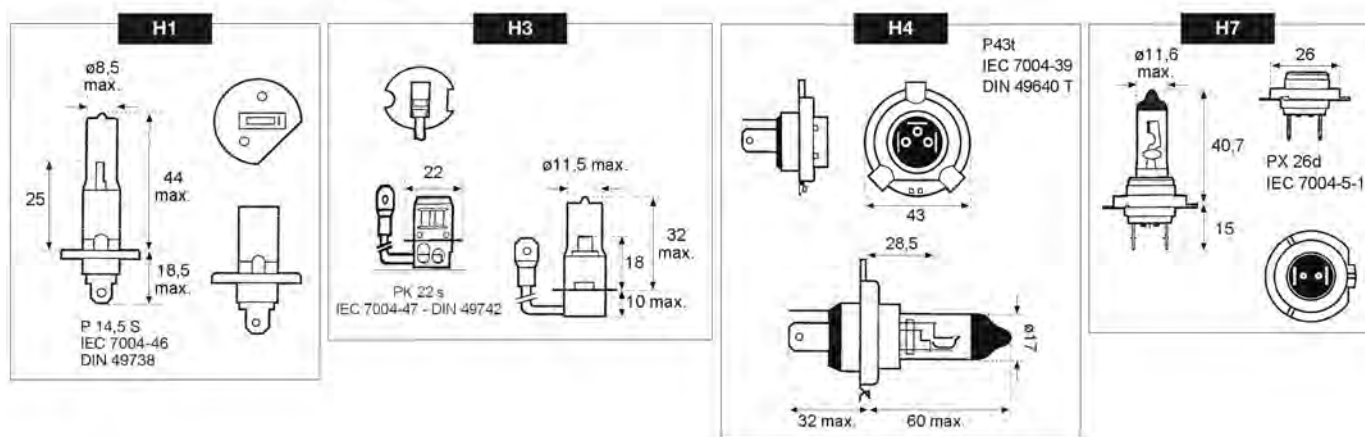

### Halogen H1 - P14,5s



Code	Desc.	Article	Cat. Int.	Attachment	V Volts	W Watt
4560008300	2502	Meccanocar	H1	P 14,5 s	12	55
4560008400	2503	Meccanocar	H1	P 14,5 s	24	70
3470004600	64150	Osram	H1	P 14,5 s	12	55
3470004608	64150ULT	Osram	H1	P 14,5 s	12	55
3470004800	64155	Osram	H1	P 14,5 s	24	70

### Halogen lamps durable H1 - P14,5s



Code	Desc.	Article	Cat. Int.	Attachment	V Volts	W Watt
4560008302	2502 HP	Meccanocar	H1	P 14,5 s	12	55

## Xenon lamps Meccanocar H1 - P14,5s - Osram cool blue



Code	Desc.	Article	Cat. Int.	Attachment	V Volts	W Watt
4560008320	2502 XN	Meccanocar	H1	P 14,5 s	12	55
4560008402	2503 XN	Meccanocar	H1	P 14,5 s	24	70
3470004605	64150 CB	Osram	H1	P 14,5 s	12	55

## Halogen H3 - PK22s



Code	Desc.	Article	Cat. Int.	Attachment	V Volts	W Watt
4560008500	2505	Meccanocar	H3	PK22s	12	55
4560008600	2506	Meccanocar	H3	PK22s	24	70
3470004700	64151	Osram	H3	PK22s	12	55
3470004802	64156	Osram	H3	PK22s	24	70

## Xenon lamp Meccanocar H3 - PK22s



Code	Desc.	Article	Cat. Int.	Attachment	V Volts	W Watt
4560008520	2505 XN	Meccanocar	H3	PK22s	12	55

## H4 halogen lamps - P43t



- \* Not approved for road use

Code	Desc.	Article	Cat. Int.	Attachment	V Volts	W Watt
4560008700	2507	Meccanocar	H4	P 43t	12	60/55
4560009500	2547 *	Meccanocar	H4	P 43t	12	100/90
4560008900	2508	Meccanocar	H4	P 43t	24	75/70
3470004900	64193	Osram	H4	P 43t	12	60/55
3470005000	64196	Osram	H4	P 43t	24	75/70

## Halogen lamps long life H4 - P43t



Code	Desc. Meccanocar	Cat. Int.	Attachment	V Volts	W Watt
4560008702	2507 HP	H4	P 43t	12	60/55
4560008901	2508 HP	H4	P 43t	24	75/70

## Xenon lamps Meccanocar H4 - P43t - Osram cool blue



- \* HIGH POWER - 50% di luminosità in più rispetto alle lampade tradizionali.

Code	Desc.	Article	Cat. Int.	Attachment	V Volts	W Watt
4560008820	2507 XN	Meccanocar	H4	P 43t	12	60/55
4560008822	2507 XN-HP *	Meccanocar	H4	P 43t	12	60/55
4560008902	2508 XN	Meccanocar	H4	P 43t	24	75/70
3470004920	64193 CB	Osram	H4	P 43t	12	60/55

## Halogen H7 - PX26d



Code	Desc.	Article	Cat. Int.	Attachment	V Volts	W Watt
4560009610	2550	Meccanocar	H7	PX26d	12	55
4560009640	2551	Meccanocar	H7	PX26d	24	70
3470005030	64210	Osram	H7	PX26d	12	55
3470005035	64215	Osram	H7	PX26d	24	70

## Halogen lamps long life H7 - PX26d



Code	Desc.	Article	Cat. Int.	Attachment	V Volts	W Watt
4560009612	2550 HP	Meccanocar	H7	PX26d	12	55
4560009641	2551 HP	Meccanocar	H7	PX26d	24	70
3470005037	64210 ULT	Osram	H7	PX26d	12	55

## Lampade Meccanocar Xenon H7 - PX26d - Osram cool blue



- \* HIGH POWER - 50% di luminosità in più rispetto alle lampade tradizionali

Code	Desc.	Article	Cat. Int.	Attachment	V Volts	W Watt
4560009630	2550 XN	Meccanocar	H7	PX26d	12	55
4560009632	2550 XN- HP *	Meccanocar	H7	PX26d	12	55
4560009642	2551 XN	Meccanocar	H7	PX26d	24	70
3470005032	64210 CB	Osram	H7	PX26d	12	55

## Lamp Meccanocar four season H7 - PX26d



Code	Desc.	Article	Cat. Int.	Attachment	V Volts	W Watt
4560010460	2910-4S	Meccanocar	H7	PX26d	12	55

## Halogen projector reinforced



- Halogen projector reinforced, resistant to shocks and vibrations, designed for use on off-road vehicles, trucks, construction equipment, earthmoving machines.

Code	Desc.	Article	Cat. Int.	Attachment	V Volts	W Watt
3470004801	64155TPS	Osram	H1	P14,5S	24	70
3470004803	64156TPS	Osram	H3	PK22S	24	70
3470005510	64196TPS	Osram	H4	P 43t	24	75/70
3470005038	64215TPS	Osram	H7	PX26d	24	70



## Lampade a doppio filamento per proiettori - ad incandescenza ed alogene

Lampade simmetriche ed asimmetriche per proiettori, in versione ad incandescenza ed alogena per la trasformazione dei fari con attacco R2-H5.

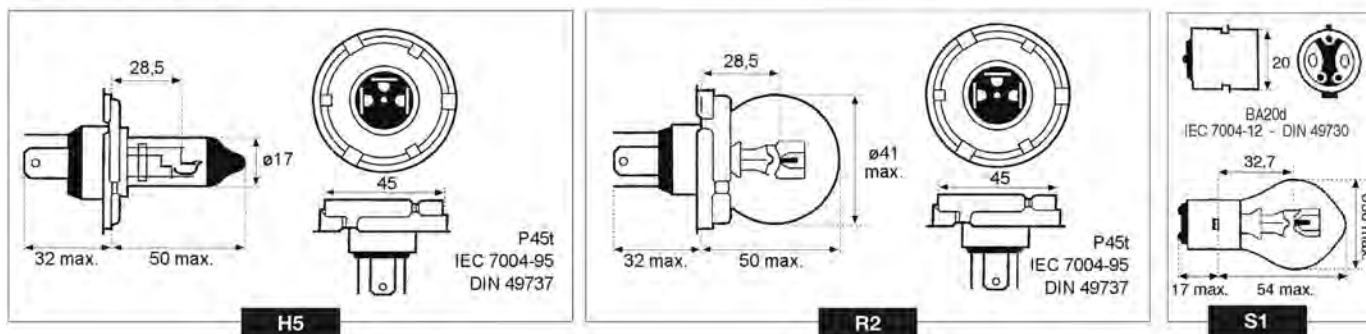

### Halogen H5



Code	Desc.	Article	Cat. Int.	Attachment	V Volts	W Watt
4560009200	2517	Meccanocar	H5	P 45t	12	60/55
4560009400	2518	Meccanocar	H5	P 45t	24	75/70
3470004500	64198	Osram	H5	P 45t	12	60/55
3470004501	64199	Osram	H5	P 45t	24	75/70

### Incandescent R2



Code	Desc.	Article	Cat. Int.	Attachment	V Volts	W Watt
4560001800	2032	Meccanocar	R2	P 45t	12	45/40
4560002000	2033	Meccanocar	R2	P 45t	24	55/50

### Incandescent S1



Code	Desc.	Article	Cat. Int.	Attachment	V Volts	W Watt
4560006100	2120	Meccanocar	S1	BA20d	12	25/25
4560001400	2020	Meccanocar	S1	BA20d	12	35/35
4560001500	2021	Meccanocar	S1	BA20d	12	45/40
4560001600	2022	Meccanocar	S1	BA20d	24	50/45



Lampade alogene per proiettori - con zoccolo in plastica

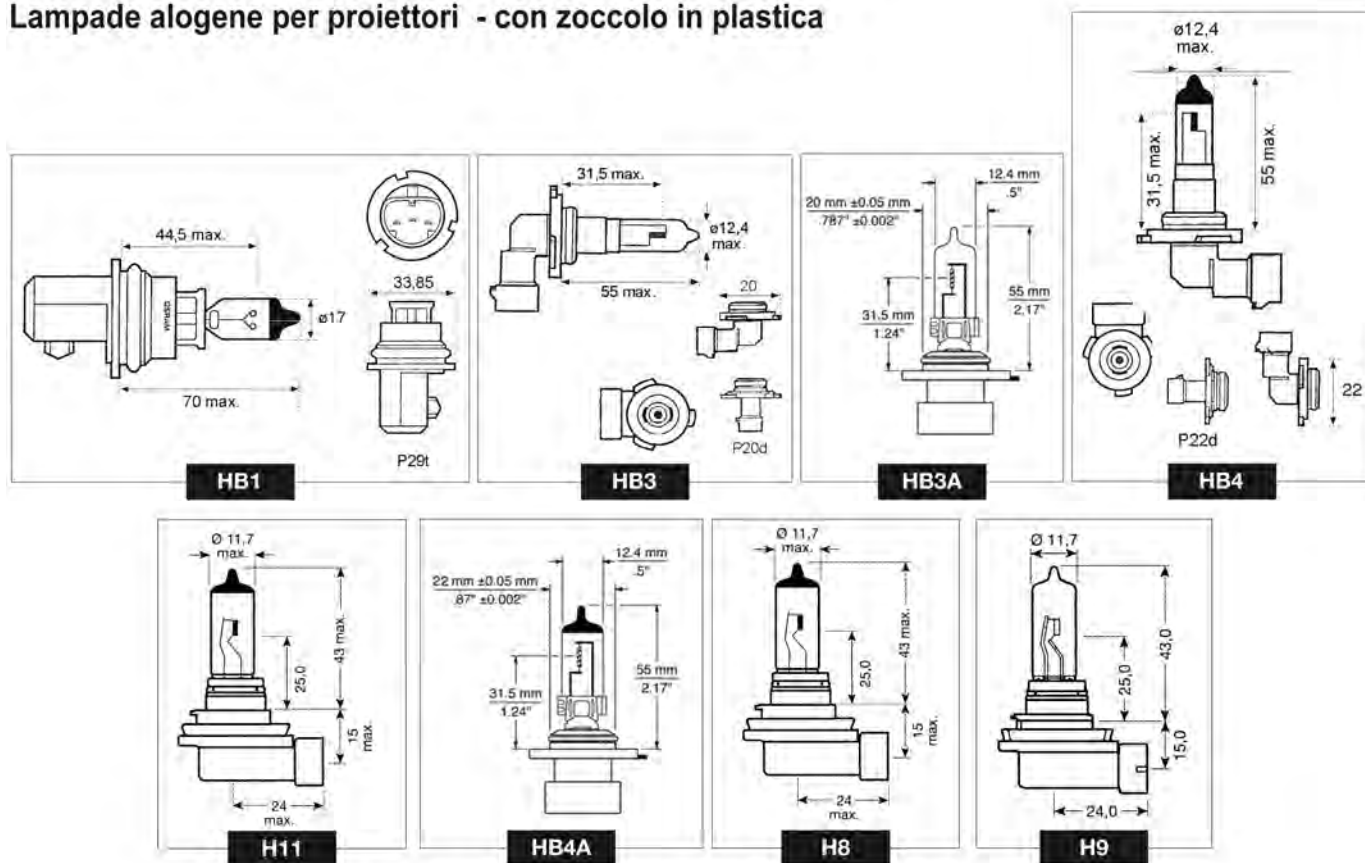

Halogen HB1



Code	Desc.	Article	Cat. Int.	Attachment	V Volts	W Watt
3470004402	9004	Osram	HB1	P29t	12	65/45

HB3 Halogen-Xenon effect (XN) -Osram cool blue (CB)



Code	Desc.	Article	Cat. Int.	Attachment	V Volts	W Watt
4560009460	2545	Meccanocar	HB3	P20d	12	60
3470004404	9005CB	Osram	HB3	P20d	12	60

HB4 halogen-Xenon effect (XN) -Osram cool blue (CB)



Code	Desc.	Article	Cat. Int.	Attachment	V Volts	W Watt
4560009450	2543	Meccanocar	HB4	P20d	12	55
4560009452	2543 XN	Meccanocar	HB4	P20d	12	55
3470004406	9006CB	Osram	HB4	P20d	12	55

## Halogen HB3A



Code	Desc.	Article	Cat. Int.	Attachment	V Volts	W Watt
3470004403	9005XS	Osram	HB3A	P20d	12	60

## Halogen HB4A



Code	Desc.	Article	Cat. Int.	Attachment	V Volts	W Watt
3470004405	9006XS	Osram	HB4A	P20d	12	51

## H8 Osram halogen and Xenon effect Meccanocar



Code	Desc.	Article	Cat. Int.	Attachment	V Volts	W Watt
4560009644	2552 XN	Meccanocar	H8	PGJ/19-1	12	35
3470005034	64212	Osram	H8	PGJ/19-1	12	35

## H11 Osram halogen and Xenon effect Meccanocar



Code	Desc.	Article	Cat. Int.	Attachment	V Volts	W Watt
4560009648	2555 XN	Meccanocar	H11	PGJ/19-2	12	55
3470005033	64211	Osram	H11	PGJ/19-2	12	55

## H11 halogen Meccanocar



Code	Desc.	Article	Cat. Int.	Attachment	W Watt	V Volts
4560009808	2565	Meccanocar	H11	PGJ/19-2	70	24

## Halogen reinforced HB4



Code	Desc.	Article	Cat. Int.	Attachment	V Volts	W Watt
4560009451	2543 HP	Meccanocar	HB4	P20d	12	55

3

## Halogen reinforced H8



Code	Desc.	Article	Cat. Int.	Attachment	V Volts	W Watt
4560009643	2552 HP	Meccanocar	H8	PGJ/19-1	12	35

## Halogen reinforced H9



Code	Desc.	Article	Cat. Int.	Attachment	V Volts	W Watt
4560009647	2553 HP	Meccanocar	H9	PGJ/19-5	12	65

## Halogen reinforced H11



Code	Desc.	Article	Cat. Int.	Attachment	V Volts	W Watt
4560009649	2555 HP	Meccanocar	H11	PGJ/19-2	12	55

## Halogen H15



Code	Desc.	Article	Cat. Int.	Attachment	V Volts	W Watt
3470004856	64176	Osram	H15	-	12	15/55
3470004857	64177	Osram	H15	-	24	20/60

## Halogen HiR1



Code	Desc.	Article	Cat. Int.	Attachment	V Volts	W Watt
3470004411	9011	Osram	HiR1	Px20d	12	65

## Halogen HiR2



Code	Desc.	Article	Cat. Int.	Attachment	V Volts	W Watt
3470004412	9012	Osram	HiR2	Px22d	12	55

## PFY lamp



Code	Desc.	Article	Cat. Int.	Attachment	V Volts	W Watt
4560008259	2399	Meccanocar	PFY	Pg20/4S	12	24

## PJ13 lamp straight



Code	Desc.	Article	Cat. Int.	Attachment	V Volts	W Watt
4560010358	2880	Meccanocar	H880	Pj13 straight	12	27

## PJ13 lamp



Code	Desc.	Article	Cat. Int.	Attachment	V Volts	W Watt
4560010361	2881	Meccanocar	H881	Pj13	12	27

## Lampade alogene e ad incandescenza per cicli e motocicli - attacchi specifici

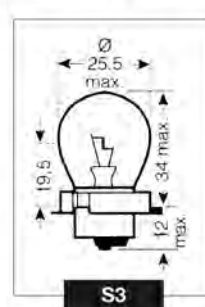
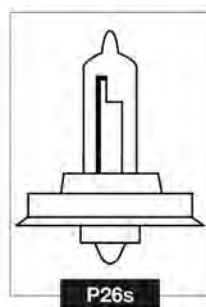
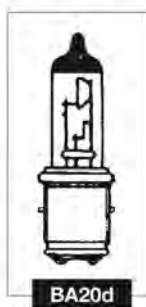
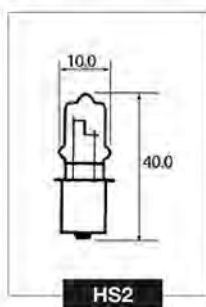
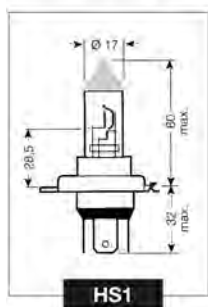

## Alogene HS1



Code	Desc.	Article	Cat. Int.	Attachment	V Volts	W Watt
4560009840	2590	Meccanocar	HS1	PX43t	12	35/35
3470004865	64185	Osram	HS1	PX43t	12	35/35

### Alogene HS2



Code	Descr. <i>Osram</i>	Cat. <i>Int.</i>	Attachment	V <i>Volts</i>	W <i>Watt</i>
3470004576	64130	HS2	PX13.5S	6	15
3470004578	64131	HS2	PX13.5S	12	15

### BA20D Meccanocar effetto Xenon



Code	Descr. <i>Meccanocar</i>	Cat. <i>Int.</i>	Attachment	V <i>Volts</i>	W <i>Watt</i>
4560009415	2520xn	-	BA20d	12	30/35

### Alogene P26S



Code	Descr. <i>Meccanocar</i>	Cat. <i>Int.</i>	Attachment	V <i>Volts</i>	W <i>Watt</i>
4560009830	2585	-	P26S	6	15
4560009835	2587	-	P26S	12	15

### Ad incandescenza P26S



Code	Descr. <i>Meccanocar</i>	Cat. <i>Int.</i>	Attachment	V <i>Volts</i>	W <i>Watt</i>	Code <i>Osram</i>	Descr. <i>Osram</i>
4560004500	2075	S3	P26S	6	15	3470002650	7130
4560004800	2077	S3	P26S	12	15	3470002655	7135



## Lampade Xenon a scarica di gas

Lampade con funzionamento ad arco elettrico in atmosfera di gas. naturali ricambi per le auto che montano di primo impianto fari "Xenon" disponibili con gli attacchi ece piu' diffusi sulle auto, sia con fari poliellissoidali sia con fari a parabola.

Le lampade xenon funzionano ad alto voltaggio, ed hanno quindi bisogno di un alimentatore dedicato montato di serie sull'auto, assorbono una corrente di soli 35 W, ed hanno una durata di circa 3.000 ore in condizioni di alimentazione ottimali. Il flusso luminoso non ha eguali, e la sicurezza che assicurano e' quanto di piu' avanzato esista oggi sul mercato.

3

### Xenon lamp D2S



Code	Desc.	Article	ECE	Attachment	V Volts	W Watt
4560010470	3000/5	Meccanocar	D2S	P32d-2	85	35
3470005047	66240	Osram	D2S	P32d-2	85	35

### Xenon lamp D2R



Code	Desc.	Article	ECE	Attachment	V Volts	W Watt
4560010480	3001/5	Meccanocar	D2R	P32d-3	85	35

### Xenon lamp D1S

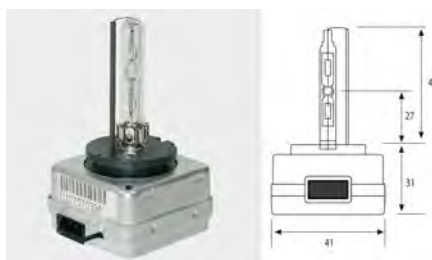

Code	Desc.	Article	ECE	Attachment	V Volts	W Watt
4560010490	3000/S	Meccanocar	D1S	PK32d-2	85	35

### Xenon lamp D1R



Code	Desc.	Article	ECE	Attachment	V Volts	W Watt
4560010500	3000/R	Meccanocar	D1R	PK32d-3	85	35

## Lampade ausiliarie per posizioni, frecce, arresto, interni ed esterni

Gamma completa di lampade ad incandescenza ed alogene per ogni tipo di applicazione, perfettamente intercambiabili con quelle montate di primo impianto, disponibili in ogni voltaggio e potenza. Serie normale e rinforzata per usi gravosi in presenza di forti vibrazioni ed urti su mezzi fuoristrada, mezzi pesanti, macchine da cantiere e movimento terra.

### Lampade ad un filamento di direzione, arresto e posizione

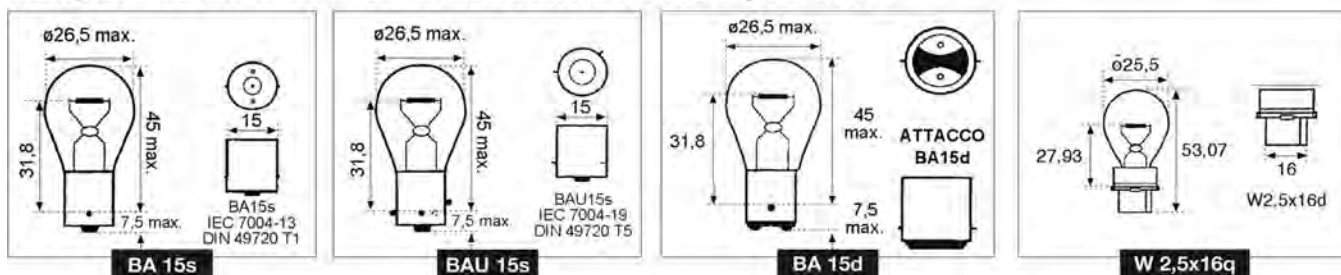

### Ad incandescenza BA15s



Code	Desc.	Article	Cat. Int.	Attachment	V Volts	W Watt
456000200	2002	Meccanocar	P21W	BA15s	12	21
456000300	2003	Meccanocar	P21W	BA15s	24	21
456000310	2003/15	Meccanocar	P21W	BA15s	24	15
3470003400	7506	Osram	P21W	BA15s	12	21
3470003500	7511	Osram	P21W	BA15s	24	21

### Incandescent BA15s - Amber - Red



Code	Desc.	Article	Cat. Int.	Attachment	V Volts	W Watt
4560010190	2801 Amber	Meccanocar	PY21W	BA15s	12	21
4560010180	2800 Rossa	Meccanocar	PY21W	BA15s	12	21

### Incandescent BA15s



Code	Desc.	Article	Cat. Int.	Attachment	V Volts	W Watt
4560000800	2010	Meccanocar	R5W	BA15s	6	5
4560000900	2011	Meccanocar	R5W	BA15s	12	5
4560001000	2012	Meccanocar	R5W	BA15s	24	5
4560005800	2110	Meccanocar	R10W	BA15s	6	10
4560005900	2111	Meccanocar	R10W	BA15s	12	10
4560010213	2811 aran.	Meccanocar	RY10W	BAU15s	12	10
4560006000	2112	Meccanocar	R10W	BA15s	24	10
3470001190	5001	Osram	R10W	BA15s	6	10
3470001200	5007	Osram	R5W	BA15s	12	5
3470001500	5627	Osram	R5W	BA15s	24	5
3470001199	5006	Osram	R5W	BA15s	6	5
3470001300	5008	Osram	R10W	BA15s	12	10
3470001650	5637	Osram	R10W	BA15s	24	10

## Incandescent BAU15s



- \* DA = white Diadema but light orange

Code	Desc.	Article	Cat. Int.	Attachment	V Volts	W Watt	Photo
4560008265	2402	Meccanocar	R21W	BAU15s	12	21	1
4560010200	2802 arancio	Meccanocar	PY21W	BAU15s	12	21	3
4560010340	2862 rossa	Meccanocar	PY21W	BAU15s	12	21	-
4560010215	2813-A arancio	Meccanocar	R10W	BAU15s	24	21	3
3470003420	7507 arancio	Osram	PY21W	BAU15s	12	21	3
3470003425	7507DA*	Osram		BAU15s	12	21	2

## Incandescent BA15d



Code	Desc.	Article	Cat. Int.	Attachment	V Volts	W Watt	Photo
4560005400	2102	Meccanocar	-	BA15d	12	21	1
4560005500	2103	Meccanocar	-	BA15d	24	21	1
4560007200	2211	Meccanocar	-	BA15d	12	5	2
4560007300	2212	Meccanocar	R5W	BA15d	24	5	2

## Incandescent W2,5x16q

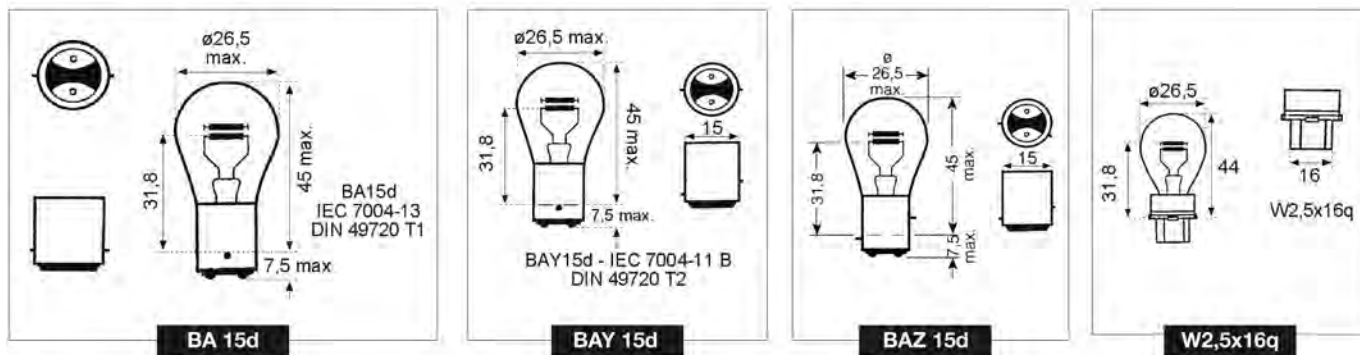

Code	Desc.	Article	Cat. Int.	Attachment	V Volts	W Watt
4560007550	2302	Meccanocar	-	W2,5x16q	12	27
3470000310	3156	Osram	-	W2,5x16q	12	27

**Lampade a doppio filamento di direzione, arresto e posizione**

**Incandescent BA15d**

Code	Desc.	Article	Cat. Int.	Attachment	V Volts	W Watt
4560005600	2107	Meccanocar	-	BA15d	12	21/5

**Incandescent BAY15d**

Code	Desc.	Article	Cat. Int.	Attachment	V Volts	W Watt
4560000500	2006	Meccanocar	P21/5W	BAY 15d	6	21/5
4560000600	2007	Meccanocar	P21/5W	BAY 15d	12	21/5
4560000700	2008	Meccanocar	P21/5W	BAY 15d	24	21/5
3470003700	7528	Osram	P21/5W	BAY 15d	12	21/5
3470004000	7537	Osram	P21/5W	BAY 15d	24	21/5

**Incandescent BAZ15d**

Code	Desc.	Article	Cat. Int.	Attachment	V Volts	W Watt
4560008270	2407	Meccanocar	P21/4W	BAZ15D	12	21/4
4560010350	2867 Rossa	Meccanocar	P21/4W	BAZ15D	12	21/4
3470002660	7225	Osram	P21/4W	BAZ15D	12	21/4

**Incandescent W2,5x16q**

Code	Desc.	Article	Cat. Int.	Attachment	V Volts	W Watt
4560007650	2307	Meccanocar	PY27/7	W2,5x16q	12	27/7
3470000312	3157	Osram	PY27/7	W2,5x16q	12	27/7
3470000390	3757AK arancio	Osram	PY27/7	W2,5x16q	12	27/7

## Lampade tutto vetro per esterni ed interni

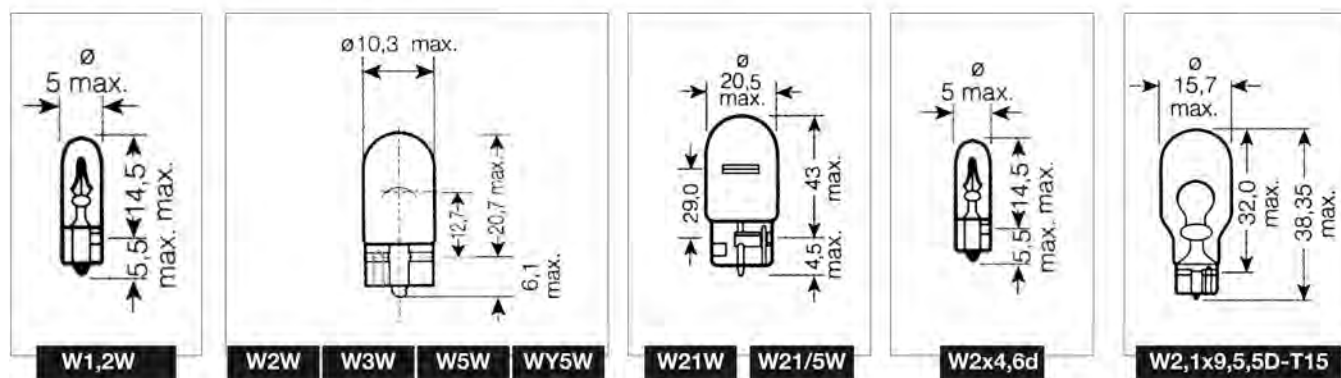

## Incandescent W1,2W1



Code	Desc.	Article	Cat. Int.	Attachment	V Volts	W Watt
4560008000	2338	Meccanocar	W1,2W	W2x4,6D	12	1,2
4560008100	2339	Meccanocar	W1,2W	W2x4,6D	24	1,2
3470000100	2721	Osram	W1,2W	W2x4,6D	12	1,2
3470000150	2741	Osram	W1,2W	W2x4,6D	24	1,2

## Ad incandescenza W2W



Code	Desc.	Article	Cat. Int.	Attachment	V Volts	W Watt
4560007737	2335	Meccanocar	W2W	W2,1x9,5D	12	2
3470000195	2820	Osram	W2W	W2,1x9,5D	12	2
3470000250	2840	Osram	W2W	W2,1x9,5D	24	2

## Ad incandescenza W3W



Code	Desc.	Article	Cat. Int.	Attachment	V Volts	W Watt
4560007800	2336	Meccanocar	W3W	W2,1x9,5D	12	3
4560007900	2337	Meccanocar	W3W	W2,1x9,5D	24	3
3470000200	2821	Osram	W3W	W2,1x9,5D	12	3
3470000300	2841	Osram	W3W	W2,1x9,5D	24	3

## Incandescent W5W



Code	Desc.	Article	Cat. Int.	Attachment	V Volts	W Watt
4560008206	2346	Meccanocar	W5W	W2,1x9,5D	12	5
4560008207	2347	Meccanocar	W5W	W2,1x9,5D	24	5
3470000210	2825	Osram	W5W	W2,1x9,5D	12	5
3470000305	2845	Osram	W5W	W2,1x9,5D	24	5



## Incandescent WY5W



- Tinted glass, extra white light

Code	Desc.	Article	Cat. Int.	Attachment	V Volts	W Watt
4560008204	2346 arancio	Meccanocar	WY5W	W2,1x9,5D	12	5
4560008205	2346 blu*	Meccanocar	WY5W	W2,1x9,5D	12	5
3470000220	2827 - arancio	Osram	WY5W	W2,1x9,5D	12	5

## Incandescent W21W



Code	Desc.	Article	Cat. Int.	Attachment	V Volts	W Watt
4560008235	2372	Meccanocar	W21W	W3x16D - T20	12	21
3470003490	7505	Osram	W21W	W3x16D - T20	12	21

## Incandescent WY21W - Amber -



Code	Desc.	Article	Cat. Int.	Attachment	V Volts	W Watt
4560008236	2372-A	Meccanocar	WY21W	W3x16D	12	21
3470003480	7504A	Osram	WY21W	W3x16D	12	21

## Incandescent W2x4,6d



Code	Desc.	Article	Cat. Int.	Attachment	V Volts	W Watt
4560008200	2340	Meccanocar	-	W2x4,6D	6	1,2
4560008208	2348	Meccanocar	-	W2x4,6D	12	2
4560008209	2349	Meccanocar	-	W2x4,6D	24	2
3470000130	2722	Osram	-	W2x4,6D	12	2

## Incandescent W21 / 5W



Code	Desc.	Article	Cat. Int.	Attachment	V Volts	W Watt
4560008240	2377	Meccanocar	W21/5W	W3x16D-T20	12	21/5

## Incandescent W2.1x9.5d, 5D-T15



Code	Desc.	Article	Cat. Int.	Attachment	V Volts	W Watt
4560008230	2370	Meccanocar	-	W2,1x9,5,5D-T15	12	10
4560008233	2371	Meccanocar	-	W2,1x9,5,5D-T15	12	21
4560008237	2373	Meccanocar	-	W2,1x9,5,5D-T15	12	16

## Lampade per posizioni ed interni

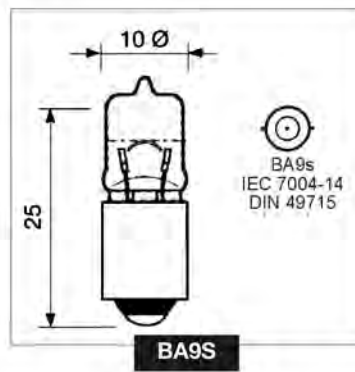
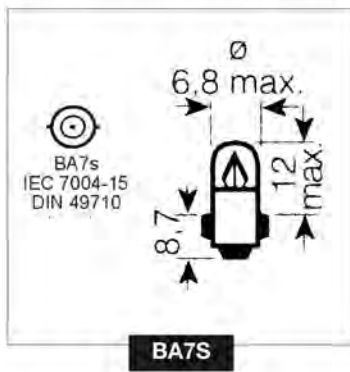

## Ad incandescenza BA7S



Code	Desc.	Article	Cat. Int.	Attachment	V Volts	W Watt
4560002400	2038	Meccanocar	T4W	BA7S	12	2
4560002500	2039	Meccanocar	T4W	BA7S	24	3

## Incandescent BA9S



Code	Desc.	Article	Cat. Int.	Attachment	V Volts	W Watt
4560002200	2036	Meccanocar	-	BA9S	12	3
4560002300	2037	Meccanocar	-	BA9S	24	3
4560007400	2235	Meccanocar	T4W	BA9S	6	5
4560007500	2236	Meccanocar	T4W	BA9S	12	5
4560006400	2137	Meccanocar	T4W	BA9S	24	4
3470001050	3930	Osram	T4W	BA9S	24	4

Lampade alogene per posizioni, direzione ed interni

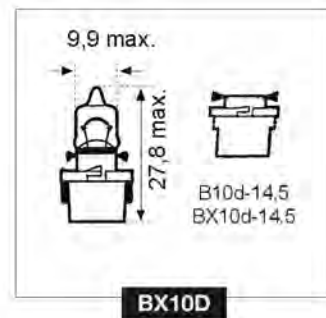
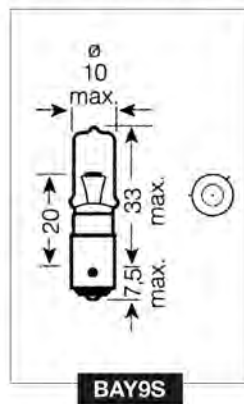
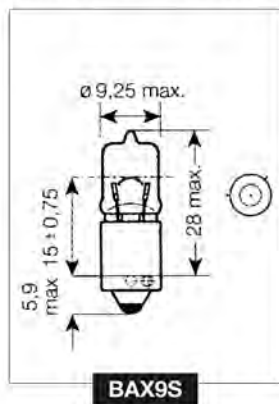

Halogen BA9S



Code	Desc.	Article	Cat. Int.	Attachment	V Volts	W Watt
3470004545	64111	Osram	-	BA9S	12	5
3470004550	64113	Osram	-	BA9S	12	10
3470004650	64115	Osram	-	BA9S	12	20

Halogen BAX9S



Code	Desc.	Article	Cat. Int.	Attachment	V Volts	W Watt
4560009437	2537	Meccanocar	H6W	BAX9S	12	6
3470004580	64132	Osram	H6W	BAX9S	12	6

Halogen BAY9S



Code	Desc.	Article	Cat. Int.	Attachment	V Volts	W Watt
4560009430	2532	Meccanocar	H21W	BAY9S	12	21
3470004592	64138	Osram	H21W	BAY9S	24	21

Halogen BX10D

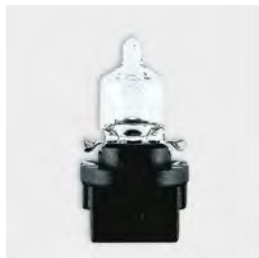

Code	Desc.	Article	Cat. Int.	Attachment	V Volts	W Watt
3470004562	64124MFX	Osram	-	BX10D	12	5

## Reinforced lamps for indoor and outdoor



- Lamps reinforced, resistant to shocks and vibrations, designed for use on off-road vehicles, trucks, construction equipment, earthmoving machines.
- Light orange

Code	Desc.	Article	Cat. Int.	Attachment	V Volts	W Watt
456000305	2003 HD	Meccanocar	P21W	BA15S	24	21
4560001005	2012 HD	Meccanocar	R5W	BA15S	24	5
3470004410	7511TPS	Osram	P21W	BA15S	24	21
3470004420	5627TPS	Osram	R5W	BA15S	24	5
3470004430	5637TPS	Osram	R10W	BA15S	24	10
3470004440	3930TPS	Osram	T4W	BA9S	24	4
3470004407	7510TPS	Osram	PY21W	BAU15S	24	21

## Auxiliary lamps long life OSRAM Ultra Life



Code	Desc.	Article	Cat. Int.	Attachment	V Volts	W Watt	Photo
3470004591	64132ULT	Osram	H6W	BAX9S	12	6	1
3470000213	2825ULT	Osram	W5W	W2,1x9,5D	12	5	2
3470003720	7528ULT	Osram	P21/5W	BAY15D	12	21/5	3
3470001220	5007ULT	Osram	R5W	BA15S	12	5	4
3470001320	5008ULT	Osram	R10W	BA15S	12	10	5
3470002011	6418ULT	Osram	C5W	SV8,5-8	12	5	6

## Auxiliary lamps torpedo

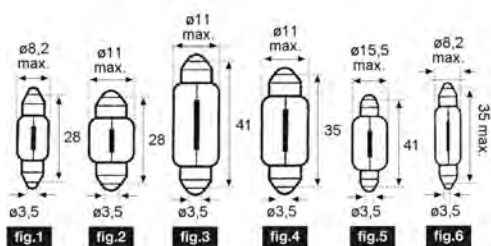
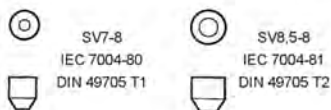

Code	Desc.	Article	Cat. Int.	Attachment	V Volts	W Watt	Fig.
4560006700	2142	Meccanocar	C5W	SV7-8	12	3	1
4560003000	2047	Meccanocar	-	SV7-8	12	5	6
4560003100	2048	Meccanocar	-	SV8,5-8	6	5	4
4560003300	2051	Meccanocar	C5W	SV8,5-8	12	5	4
4560003400	2052	Meccanocar	C5W	SV8,5-8	12	10	4
4560003500	2053	Meccanocar	C5W	SV8,5-8	24	5	4
4560006900	2153	Meccanocar	C5W	SV8,5-8	24	10	4
4560006810	2148	Meccanocar	-	SV8,5-8	6	5	3
4560008211	2351	Meccanocar	C5W	SV8,5-8	12	5	3
4560008212	2352	Meccanocar	C5W	SV8,5-8	12	10	3
4560008213	2353	Meccanocar	C5W	SV8,5-8	24	5	3
4560003900	2057	Meccanocar	C5W	SV8,5-8	12	20	5
3470002130	6430	Osram	C5W	SV7-8	24	3	1
3470002000	6418	Osram	C5W	SV8,5-8	12	5	4
3470002600	6461	Osram	C5W	SV8,5-8	12	10	4
3470002050	6423	Osram	C5W	SV8,5-8	24	5	4
3470001800	6413	Osram	C5W	SV8,5-8	12	5	3
3470001700	6411	Osram	C5W	SV8,5-8	12	10	3
3470002140	6438	Osram	C5W	SV8,5-8	12	10	2



## Lamps miniwatt mount plastic



- MF = 2 mm thick plates
- MFX = 1.6 thick plates



Code	Desc.	Article	Color	Attachment	V Volts	W Watt	Fig.
4560008248	2388	Meccanocar	nero	B8.5d	12	1.2	6
4560008249	2389	Meccanocar	grigio	B8.5d	24	1.2	6
3470000110	2721MF	Osram	nero	B8.5d	12	1.2	6
3470000170	2741MF	Osram	grigio	B8.5d	24	1.2	6
3470000120	2722MF	Osram	verde chiaro	B8.5d	12	2	6
3470000073	2351MFX6	Osram	nero	Bx8.4d	12	1.2	5
3470000074	2452MFX6	Osram	beige	Bx8.4d	12	1.5	5
3470000076	2452MFX6	Osram	verde chiaro	Bx8.4d	12	2	5
3470000078	2473MFX6	Osram	arancio	Bx8.4d	12	1.12	5
3470000111	2721MFX	Osram	azzurro	B8.5d	12	1.2	7
3470000122	2722MFX	Osram	verde chiaro	B8.5d	12	2	7
3470000125	2722MF8	Osram	bianco	B8.3d	12	2	8
3470000176	2741MFX	Osram	rame	B x 8,5d	24	1.2	9

## LED lamps for vehicles

- Auxiliary lamps for vehicles with LED technology which offer many advantages compared to traditional incandescent and halogen such as high brightness , low power consumption, ruggedness and durability, insensitivity' to shock, vibration and humidity , ignition time almost' immediate, more safety while driving. Perfectly compatible with traditional attacks used on all the vehicles, with the supply voltage at 12 and 24 volts.
- Product intended for: drivers, machine shops and VI, VI and auto body shops, workshops tuning.
- Advantages: high energy saving, low heat output, high luminous efficiency, increased service intervals and replacement of lamps, ignition timing immediate and thus safety, perfect compatibility 'with traditional attacks present at lighthouses, aesthetics of light emitted more' attractive and visible.
- Available in assorted colors.
- Please note: due to the low consumption of LED lamps, some means check control board may, with their use, failure to report non-existent. in these cases must be mounted in parallel to the LED lamp by a resistance that simulates the correct current consumption

### BA15s - 21W

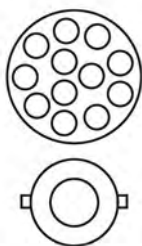

- Lampade a led con attacco BA15s, potenza luminosa emessa come lampade tradizionali da 21 Watt.
- Utilizzo tipico: indicatori di direzione, luci di arresto e retronebbia.

Code	Desc.	Attachment	Dimensions	V Volts	W Watt	N° led	Color
4560010600	3100	BA15s	Ø 25,6 mm	12	21	12	white
4560010610	3110	BA15s	Ø 25,6 mm	12	21	12	orange
4560010615	3115	BA15s	Ø 25,6 mm	24	21	12	white
4560010620	3120	BA15s	Ø 25,6 mm	24	21	12	red
4560010625	3125	BA15s	Ø 25,6 mm	24	21	12	orange
4560010627	3127	BA15s	Ø 25,6 mm	24	21	12	white

### BA15s - 5W

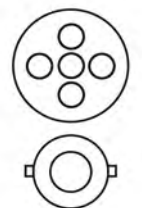

- LED lamps with BA15s attack, power emitted light as traditional lamps 5 Watt.
- Typical use: lights and marker.

Code	Desc.	Attachment	Dimensions	V Volts	W Watt	N° led	Color
4560010660	3160	BA15S	Ø 18,5 mm	12	5	5	white
4560010670	3170	BA15S	Ø 18,5 mm	12	5	5	orange
4560010680	3180	BA15S	Ø 18,5 mm	24	5	5	red
4560010685	3185	BA15S	Ø 18,5 mm	24	5	5	blue
4560010687	3187	BA15S	Ø 18,5 mm	24	5	5	white

### BA15s – 21W - Led laterali

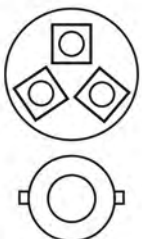

- Led lamps of new generation, with led side for a better light diffusion.
- Attack BA15s, light power output as conventional lamps from 21 watts.
- Typical use: turn signals, brake lights and rear fog light.

Code	Desc.	Attachment	Dimensions	V Volts	W Watt	N° led	Color
4560010780	3280	BA15S	Ø 25 mm	12	21	13	orange
4560010785	3285	BA15S	Ø 25 mm	12	21	13	red
4560010790	3290	BA15S	Ø 25 mm	12	21	13	white
4560010795	3295	BA15S	Ø 25 mm	24	21	13	orange
4560010800	3300	BA15S	Ø 25 mm	24	21	13	red
4560010805	3305	BA15S	Ø 25 mm	24	21	13	white

## BAU15s - 21W

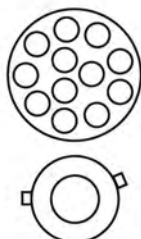

- LED lamps with attack BAU15s, light power output as conventional lamps from 21 watts.
- Typical use: turn signals.

Code	Desc.	Attachment	Dimensions	V Volts	W Watt	N° led	Color
4560010630	3130	BAU15s	Ø 25,6 mm	12	21	12	orange
4560010635	3135	BAU15s	Ø 25,6 mm	24	21	12	orange

## BAU15s - 21W - LED side



- LED lamps of new generation, with led side for a better light diffusion.
- BAU15s attack, power emitted light as traditional lamps from 21 watts.
- Typical use: turn signals.

Code	Desc.	Attachment	Dimensions	V Volts	W Watt	N° led	Color
4560010810	3310	BAU15s	Ø 25 mm	12	21	13	orange
4560010815	3315	BAU15s	Ø 25 mm	24	21	13	orange

## BAY15d - 21/5W

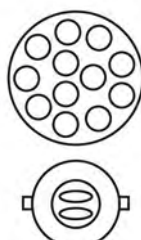

- LED lamps with BAY15d attack, power emitted light as traditional lamps, double-stranded from 5.21 Watt.
- Typical use: taillights and stop.

Code	Desc.	Attachment	Dimensions	V Volts	W Watt	N° led	Color
4560010640	3140	BAY15d	Ø 25,6 mm	12	21/5	12	white
4560010645	3145	BAY15d	Ø 25,6 mm	12	21/5	12	red
4560010650	3150	BAY15d	Ø 25,6 mm	24	21/5	12	white
4560010655	3155	BAY15d	Ø 25,6 mm	24	21/5	12	red

## BAY15d - 21 / 5W - LED side

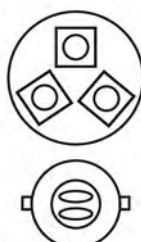

- LED lamps of new generation, with led side for a better light diffusion.
- BAY15d attack, power emitted light as traditional lamps, double-stranded from 5.21 Watt.
- Typical use: taillights and stop.

Code	Desc.	Attachment	Dimensions	V Volts	W Watt	N° led	Color
4560010820	3320	BAY15d	Ø 25 mm	12	21/5	13	red
4560010825	3325	BAY15d	Ø 25 mm	12	21/5	13	white
4560010830	3330	BAY15d	Ø 25 mm	24	21/5	13	red
4560010835	3335	BAY15d	Ø 25 mm	24	21/5	13	white

3

## BA9st9 - 4W



- LED lamps with BA9st9 attack, power emitted light as traditional lamps 4 Watt.
- Typical use: lights and marker, license plate lights.

Code	Desc.	Attachment	Dimensions	V Volts	W Watt	N° led	Color
4560010690	3190	BA9st9	Ø 9 mm	12	4	4	white
4560010695	3195	BA9st9	Ø 9 mm	24	4	4	blue
4560010700	3200	BA9st9	Ø 9 mm	24	4	4	white

## Torpedo

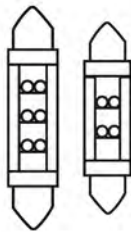

- LED lamps with a torpedo attack, power emitted light as traditional lamps 5 and 10 watts.
- Typical use: interior lights, license plate lights, marker lights.

Code	Desc.	Dimensions	V Volts	W Watt	N° led	Color
4560010705	3205	10,5x31	12	10	4	white
4560010710	3210	10,5x38	12	5	4	white
4560010715	3215	10,5x38	24	5	4	white
4560010720	3220	10,5x38	24	5	4	blue
4560010725	3225	11x41	24	5	6	white

## P/W-W3X16d - 21-21/5W



- LED lamps with attack PW-W3x16d, light power output as conventional lamps from 21 watts to 5.21 watts and double-stranded.
- Typical use: stop lights, position lights and stop, rear fog lights, direction indicators.

Code	Desc.	Attachment	Dimensions	V Volts	W Watt	N° led	Color
4560010730	3230	P/W - W3X16d	Ø 26 mm	12	21	12	orange
4560010735	3235	P/W - W3X16d	Ø 26 mm	12	21	12	white
4560010740	3240	P/W - W3X16d	Ø 26 mm	12	21/5	12	white

## W2X4,6d – 1,2W



- All glass LED lamps model. light power output as conventional lights 1.2 W.
- Typical use: indoor lighting, lights, smoke and dashboard instrumentation.

Code	Desc.	Attachment	Dimensions	V Volts	W Watt	N° led	Color
4560010750	3250	W2X4,6d	Ø 5 mm	12	1,2	1	white
4560010755	3255	W2X4,6d	Ø 5 mm	24	1,2	1	White

## W2,1X9,5d – 5 W



- All glass LED lamps model. power emitted light as traditional lamps 5 Watt.
- Typical use: interior lighting, parking lights, number plate lights.

Code	Desc.	Attachment	Dimensions	V Volts	W Watt	N° led	Color
4560010760	3260	W2,1X9,5d	Ø 9 mm	12	5	3	white
4560010765	3265	W2,1X9,5d	Ø 9 mm	24	5	3	White
4560010770	3270	W2,1X9,5d	Ø 9 mm	12	5	3	Blue
4560010775	3275	W2,1X9,5d	Ø 9 mm	24	5	3	blue

## Load resistors



- Dummy load resistors for LED lamps.
- They should be installed in the case in which the on-board computer signals anomalies after mounting the lamps. It simulates the consumption of an incandescent lamp allowing the check control not to report events or faults exist.
- The assembly is done in any part of the supply circuit of the lamps, in parallel with the lamp itself, by connecting the terminals between the positive pole and the negative pole.
- The resistance is not polarized and can be attached at any point of the plant, fixing the bracket to a metal part of the frame to facilitate the heat dissipation.

Code	Desc.	Article
4560010840	3340	Resistance for LED lamps 12V 5W - 22 Ω
4560010845	3345	Resistance for LED lamps 21W 12V - 6.8 Ω
4560010850	3350	Resistance for LED lamps 5W 24V - 4.8 Ω
4560010855	3355	Resistance for LED lamps 21W 24V - 1.2 Ω



## Cosmetic bag replacement lamps in plastic



- Box with provision for dual lamp projector
- Version / g contains 1 lamp 12V / 21W yellow + 1 12V / 21W standard instead of '2 lamps 12V / 21W standard

### COMPOSIZIONI TROUSSE

#### COMPOSIZIONE TROUSSE 12V-STANDARD:

- 1 LAMPADA PROIETTORE
- 2 LAMPADIE 12V/21W ATTACCO BA15S
- 1 LAMPADA 12V/5W ATTACCO BA15S
- 1 LAMPADA TUTTO VETRO 12V/5W ATTACCO W2.1X9.5d
- 2 FUSIBILE LAMELLARE

#### COMPOSIZIONE TROUSSE 12V-BILUCE:

- 1 LAMPADA PROIETTORE
- 1 LAMPADIE 12V/21W ATTACCO BA15S
- 1 LAMPADA 12V-5/21W ATTACCO BAY15d
- 1 LAMPADA 12V/5W ATTACCO BA15S
- 1 LAMPADA TUTTO VETRO 12V/5W ATTACCO W2.1X9.5d
- 2 FUSIBILE LAMELLARE

#### COMPOSIZIONE TROUSSE 24V-STANDARD:

- 1 LAMPADA PROIETTORE
- 2 LAMPADIE 24V/21W ATTACCO BA15S
- 1 LAMPADA 24V/5W ATTACCO BA15S
- 1 LAMPADA 24V/4W ATTACCO BA9S
- 2 FUSIBILE LAMELLARE

Code	Desc.	Cat. Int.	V Volts
3470005210	1516/B	H4	12
3470005250	1516/24	H4	24
3470005420	1520	HB3	12
3470005200	1516	H4	12
3470005205	1516/G	H4	12
3470005410	1519	H7	12
3470005415	1519/G	H7	12

## Cabinet lampholders



- The ideal kit for lamps always tidy and views
- Cupboard painted sheet
- Plexiglas sliding doors
- With 4 adjustable shelves
- With two anchors for wall mounting

### POSSIBILE CONTENUTO

LAMPADIE AUTO 12V		LAMPADIE AUTO 24V	
n° 12	H4 456 00 08700 2507	n° 12	456 00 08900 2508
n° 12	H7 456 00 09610 2550	n° 12	456 00 09640 2551
n° 8	H1 456 00 08300 2502	n° 8	456 00 08400 2503
n° 50	P21W 456 00 00200 2002	n° 50	456 00 00300 2003
n° 10	P21W 456 00 10200 2802G	n° 30	456 00 00700 2008
n° 20	P21/5W 456 00 00600 2007	n° 50	456 00 01000 2012
n° 50	R5W 456 00 00900 2011	n° 20	C5W 456 00 03500 2053
n° 50	WY5W 456 00 08206 2346	n° 8	H3 456 00 08600 2506
n° 10	WY5W 456 00 08204 2346G		

Code	Desc.	Dimensions mm
4700003395	2539	450x550x150

## FARO DA LAVORO ORIENTABILE



- ø mm 140.
- Corpo nylon nero.
- Interruttore.
- Griglia di protezione.
- (Lampada H3 non fornita).
- Prodotto fornito senza cavi.
- Lampade utilizzabili impianto 12V: n°1 cod. 3470004700

Code	Description
4280000500	50

## Faro da lavoro orientabile



- Dimensioni mm 180x95.
- Corpo nylon nero.
- (Lampada H3 non fornita).
- Prodotto fornito senza cavi.
- Lampade utilizzabili impianto 12V: n°1 cod. 3470004700
- Lampade utilizzabili impianto 24V: n°1 cod. 3470004802

Code	Description
4280000510	51

## FARO DA LAVORO PORTATA 25 METRI



- Faro da lavoro compatto, con corpo in plastica rinforzata con fibre di vetro, resistente agli acidi ed esente da corrosione.
- Grazie alla compattezza delle sue dimensioni, il faro è utilizzabile a livello universale, in particolare nel movimento terra, settore agricolo e settore edilizia.
- Fissaggio con staffa centrale con vite M10.
- Montaggio a sbalzo in posizione verticale o sospeso.
- Angolo di inclinazione raccomandato: 10° - 15°.
- Fornito senza lampada (H3).
- Tensione di alimentazione: 12 - 24V.
- Passaggio cavi attraverso un'apertura nella calotta in gomma.
- Grado di protezione: IP5K4K.
- Portata max 25 metri.

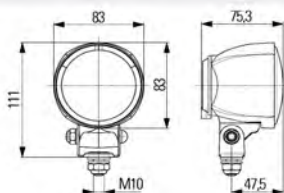

Code	Description
4280007650	2435

## FARO DA LAVORO PORTATA 30 METRI

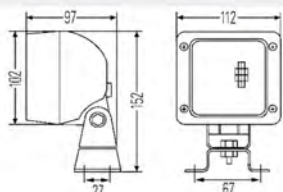

- Faro da lavoro con corpo nero in plastica rinforzata con fibra di vetro, bordo sporgente a protezione del trasparente.
- Utilizzabile a livello universale, in particolare nel movimento terra, settore agricolo e settore edilizia.
- Fissaggio con staffa a u con dispositivo antivibrazione (vite di fissaggio M10).
- Montaggio a sbalzo in posizione verticale o sospeso.
- Angolo di inclinazione raccomandato: 15° - 20°.
- Tensione di alimentazione: 12 - 24V.
- Dotato di passafilo.
- Fornito senza lampada (H3).
- Grado di protezione: IP5K4K.
- Portata max 30 metri.

Code	Description
4280007660	2445

## FARO DA LAVORO PORTATA 25 METRI

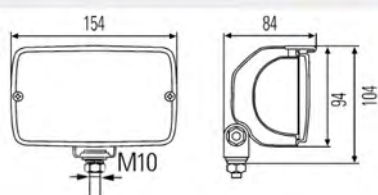

- Faro da lavoro con lente in vetro e luce diffusa.
- Utilizzabile a livello universale, in particolare nel movimento terra, settore agricolo e settore edilizia.
- Fissaggio con staffa centrale con vite M10.
- Montaggio a sbalzo in posizione verticale o sospeso.
- Orientabile verticalmente su 130°.
- Tensione di alimentazione: 12 - 24V.
- Dotato di passafilo.
- Fornito senza lampada (H3).
- Grado di protezione: IP5K4K.
- Portata max 25 metri.

Code	Description
4280007670	2455

## FARO DA LAVORO PORTATA 100 METRI

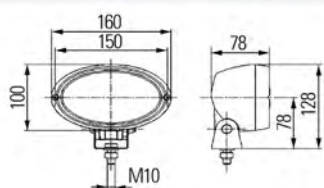

- Faro da lavoro con vetro senza prismature.
- Utilizzabile a livello universale, in particolare nel movimento terra, settore agricolo e settore edilizia.
- Fissaggio con staffa centrale con vite M10.
- Montaggio a sbalzo in posizione verticale o sospeso.
- Tensione di alimentazione: 12 - 24V, con attacco faston passo 6,3.
- Fornito con 2 lampade H3 12V 55W, nostri codd. 456 00 08500-2505 / 3470004700.
- Possibilità di montaggio su impianto a 24V con lampada H3 70W, nostri codd. 456 00 08600-2506 / 347 00 04802-64156.
- Grado di protezione: IP5K4K.
- Distribuzione della luce per illuminazione a lungo raggio, fino a 100 metri.

Code	Description
4280007680	2465

## FARO DA LAVORO



- Faro da lavoro.
- Può montare lampade H3 12v55w =4560008300-2502-3470004700-64151.
- Oppure H3 24v-70W=4560008400-2503-3470004802-64156
- Con base di fissaggio.
- Dimensioni:D.98x118x105mm.

Code	Description
4280011900	Faro D.98

## FARO DA LAVORO



- Faro da lavoro.
- Può montare lampade H3 12v55w =4560008300-2502-3470004700-64151.
- Oppure H3 24v-70W=4560008400-2503-3470004802-64156.
- Con griglia di protezione in plastica.
- Con interruttore e maniglia.
- Dimensioni:D.158x184x65mm.

Code	Description
4280011910	Faro D.158

## FARO DA LAVORO



- Può montare lampade H3 12v55w =4560008300-2502-3470004700-64151
- Oppure H3 24v-70W=4560008400-2503-3470004802-64156
- Con base di fissaggio.
- Senza interruttore.
- Dimensioni:110x110mm.

Code	Description
4280011920	Faro quadro

## FARO DA LAVORO



- Può montare lampade H3 12v55w =4560008300-2502-3470004700-64151.
- Oppure H3 24v-70W=4560008400-2503-3470004802-64156.
- Con base di fissaggio.
- Con interruttore e maniglia.
- Dimensioni:110x110mm.

Code	Description
4280011930	Faro quadro con maniglia



## WORK LIGHT LED 10/30V



- Work light LED 10 / 30V.
- Aluminum body.
- LED power 1x10w-700 lumens.
- Consumption: 1A-12V / 0.5A-24V.
- Size: 66x55x55mm.
- 6000k color temperature.
- IP67 protection.

Code	Description
4280012010	Faro led 10/30V

## LIGHT WORK LED 9/33V



- Aluminum body.
- Power led 4x3w-700 lumens.
- Consumption: 1A-12V / 0.5A-24V.
- Size:83x100x43mm.
- Colour Temperature 6000k.
- IP67 protection.

Code	Description
4280012020	Faro led 10/30V

## Proiettore orientabile da lavoro a Led



- Tensione di alimentazione 10-30V
- Potenza 18Watt-1500LM
- Diametro 100mm

Code	Description	Original ref.
4280012350	Proiettore Led 18w	av.05.0042.01



## Proiettore orientabile da lavoro a Led



- Tensione di alimentazione 10-30V
- Potenza 12Watt-800LM
- Dimensioni: 70x70mm

Code	Description	Original ref.
4280012320	Proiettore Led 12w	av.05.0044.01

## Proiettore orientabile da lavoro a Led



- Tensione di alimentazione 10-30V
- Potenza 15Watt-1200LM
- Dimensioni: 100x100mm

Code	Description	Original ref.
4280012340	Proiettore Led 15w	av.05.0043.01

## LED INNOVATION

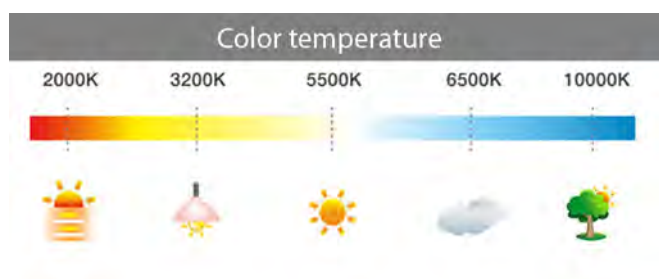
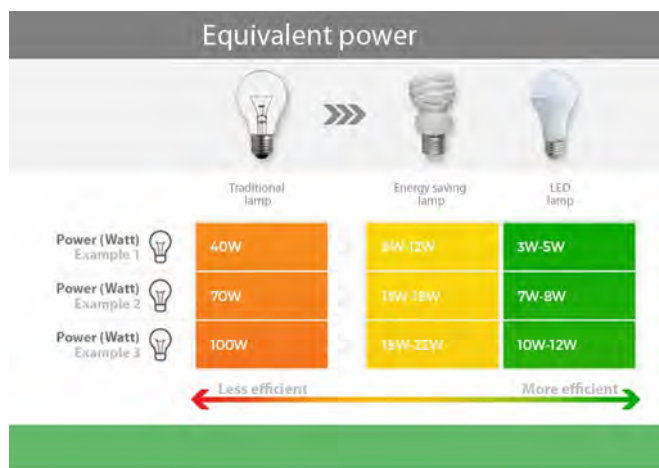

«The most convenient energy solution for industry, commerce and craft sectors»

LED light bulbs are widely used in offices, commercial areas, high-precision rooms, technical studios, salons, retail outlets, workshops and external spaces. They have a longer working life and emit some heat.

«LED technology is considered the winning solution amongst all other technologies on the market»

Undoubtedly, they consume less electric energy, thanks to their functioning power/absorption that is clearly less and does not necessitate maintenance being insensitive to humidity and cold. LED lighting can generate a much clearer light that strains the operator's eyes less and can be utilised also to highlight a product or create an atmosphere that attracts interest. It is a sustainable technology, giving soft shapes and clean lines, lasts 5 times more than any other fluorescent or neon light bulb; it lasts approximately 25,000 working hours with a CRI>80 high yield chromatic capacity and has energy capacity A+.

Our range of products is available in different tonalities of luminosity:

- Warm light or yellow light corresponds to 3000k and is preferred for applications in internal environments, such as offices or homes, thanks to its soft and warm light.
- Neutral or natural light corresponds to 4000k.
- Cool light or white light corresponds to 5500k/6500k. It is a clear and clean light close to daylight tonalities and preferred to illuminate large open spaces or zones in which it is important to have the efficiency and definition of details.

## LED mini ball light bulb



- A professional product, easy and quick to install and suitable for all lamp holders with the old halogen or fluorescent technology.
- Remove the old incandescent light bulb and replace it with a new LED bulb and check beforehand that the two light bulbs function at the same voltage as the power supply and that the light bulb cap is the same.
- Switching on is immediate, as is the saving of electrical energy that starts right from the first invoice. Furthermore, in order to make greater energy saving, it is recommended change all light bulbs of the electrical system to the new LED light bulbs.

Code	Description	Attachment	Power <i>Led / tradit.</i>	Voltage <i>(V)</i>	Lum. flow	Dimensions	Temp. <i>colour light</i>	Current
5180000120	Mini ball 6w-230-3000K-E14	E14	6w / 40w	220/240v	470lm, 180°	Ø45, 74mm	3000K Warm L.	45mA
5180000130	Mini ball 6w-230-6400K-E14	E14	6w / 40w	220/240v	470lm, 180°	Ø45, 74mm	6400K Cold L.	45mA
5180000140	Mini ball 6w-230-3000K-E27	E27	6w / 40w	220/240v	470lm, 180°	Ø45, 76mm	3000K Warm L.	45mA
5180000150	Mini ball 6w-230-6400K-E27	E27	6w / 40w	220/240v	470lm, 180°	Ø45, 76mm	6400K Cold L.	45mA

## LED candle light bulb

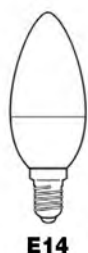

E14



- Prodotto professionale facile e veloce da installare, adattabile a qualsiasi porta lampada con vecchia tecnologia alogena o fluorescente.
- L'installazione è semplice e veloce, svitare la vecchia lampada ad incandescenza e riavvitare quella nuova a Led, controllando preventivamente che le due lampade funzionino alla stessa tensione di alimentazione e che l'attacco sia il medesimo.
- L'accensione è immediata come il risparmio di energia elettrica, già dalle prime bollette. Per poter beneficiare di un ulteriore maggior risparmio energetico, si consiglia di sostituire tutte le lampade presenti sull'impianto elettrico con quelle nuove a Led.

3

Code	Description	Attachment	Power <i>Led / tradit.</i>	Voltage <i>(V)</i>	Lum. flow	Dimensions	Temp. <i>colour light</i>	Current
5180000160	candle light bulb 6w-230-3000K-E14	E14	6w / 40W	220/240v	470lm, 240°	Ø37x100mm	3000 K Warm L.	45mA
5180000170	candle light bulb 6w-230-6400k-E14	E14	6w / 40W	220/240v	470lm, 240°	Ø37x100mm	6400K Warm L.	45mA

## LED Goccia lamp



E27



- A professional product, easy and quick to install and suitable for all lamp holders with the old halogen or fluorescent technology.
- Remove the old incandescent light bulb and replace it with a new LED bulb and check beforehand that the two light bulbs function at the same voltage as the power supply and that the light bulb cap is the same.
- Switching on is immediate, as is the saving of electrical energy that starts right from the first invoice. Furthermore, in order to make greater energy saving, it is recommended change all light bulbs of the electrical system to the new LED light bulbs.

Code	Description	Attachment	Power <i>Led / tradit.</i>	Voltage <i>(V)</i>	Lum. flow	Dimensions	Temp. <i>colour light</i>	Current
5180000180	Goccia 9w-230-3000K-E27	E27	9w / 60w	220/240v	806lm, 300°	Ø60, 112mm	3000K Warm L.	74mA
5180000190	Goccia 9w-230-6400k-E27	E27	9w / 60w	220/240v	806lm, 300°	Ø60, 112mm	6400K Cold L.	74mA
5180000200	Goccia 12w-230-3000K-E27	E27	12w / 75w	220/240v	1055lm, 300°	Ø60, 112mm	3000K Warm L.	91mA
5180000210	Goccia 12w-230-6400K-E27	E27	12w / 75w	220/240v	1055lm, 300°	Ø60, 112mm	6400K Cold L.	91mA
5180000220	Goccia 15w-230-3000K-E27	E27	15w / 100w	220/240v	1500lm, 300°	Ø65, 127mm	3000K Warm L.	124mA
5180000230	Goccia 15w-230-6400K-E27	E27	15w / 100w	220/240v	1500lm, 300°	Ø65, 127mm	6400K Cold L.	124mA

## LED Goccia lamp

3



- A professional product, easy and quick to install and suitable for all lamp holders with the old halogen or fluorescent technology.
- Remove the old incandescent light bulb and replace it with a new LED bulb and check beforehand that the two light bulbs function at the same voltage as the power supply and that the light bulb cap is the same.
- Switching on is immediate, as is the saving of electrical energy that starts right from the first invoice. In order to make greater energy saving, it is recommended change all light bulbs of the electrical system to the new LED light bulbs.

Code	Description	Attachment	Power <i>Led / tradit.</i>	Voltage <i>(V)</i>	Lum. flow	Dimensions	Temp. <i>colour light</i>	Current
5180000240	Goccia 18w-230-3000K-E27	E27	18w / 110w	220/240v	1700lm, 270°	Ø60, 129mm	3000K Warm L.	142mA
5180000250	Goccia 18w-230-6400K-E27	E27	18w / 110w	220/240v	1700lm, 270°	Ø60, 129mm	6400K Cold L.	142mA
5180000260	Goccia 24w-230-3000K-E27	E27	24w / 140w	220/240v	2200lm, 270°	Ø80, 160mm	3000K Warm L.	187mA
5180000270	Goccia 24w-230-6400K-E27	E27	24w / 140w	220/240v	2452lm, 270°	Ø80, 160mm	6400K Cold L.	187mA

## LED GU5.3 white spotlight



- Prodotto professionale facile e veloce da installare, adattabile a qualsiasi porta lampada, con vecchia tecnologia alogena o fluorescente.
- Svitare la vecchia lampada ad incandescenza e reinserire quella nuova a Led, controllando preventivamente che le due lampade funzionino alla stessa tensione di alimentazione e che l'attacco sia il medesimo.
- L'accensione è immediata come il risparmio di energia elettrica, già dalle prime bollette. Per poter beneficiare di un ulteriore maggior risparmio energetico, si consiglia di sostituire tutte le lampade presenti sull'impianto elettrico con quelle nuove a Led.

Code	Description	Attachment	Power <i>Led / tradit.</i>	Voltage <i>(V)</i>	Lum. flow	Dimensions	Temp. <i>colour light</i>	Current
5180000310	Spotlight 6w-12-GU5.3	GU 5.3	6w / 40w	12vDC/AC	385lm, 60°	Ø50, 45mm	3000K Warm L.	640mA

## LED GU10 white spotlight



- Prodotto professionale facile e veloce da installare, adattabile a qualsiasi porta lampada, con vecchia tecnologia alogena o fluorescente.
- Svitare la vecchia lampada ad incandescenza e reinserire quella nuova a Led, controllando preventivamente che le due lampade funzionino alla stessa tensione di alimentazione e che l'attacco sia il medesimo.
- L'accensione è immediata come il risparmio di energia elettrica, già dalle prime bollette. Per poter beneficiare di un ulteriore maggior risparmio energetico, si consiglia di sostituire tutte le lampade presenti sull'impianto elettrico con quelle nuove a Led.

3

Code	Description	Attachment	Power <i>Led / tradit.</i>	Voltage <i>(V)</i>	Lum. flow	Dimensions	Temp. <i>colour light</i>	Current
5180000320	Spotlight 7w-230-GU10	GU10	7w / 50w	220/230v	480lm, 120°	Ø50, 59mm	4000K Neutral L.	89mA

## 12/24v LED light bulb



- A professional product, easy and quick to install and suitable for all lamp holders with the old halogen or fluorescent technology.
- Remove the old incandescent light bulb and replace it with a new LED bulb and check beforehand that the two light bulbs function at the same voltage as the power supply and that the light bulb cap is the same.
- Switching on is immediate, as is the saving of electrical energy that starts right from the first invoice. Furthermore, in order to make greater energy saving, it is recommended to change all light bulbs of the electrical system to the new LED light bulbs.
- It can be utilised for workshop inspection lamps that have an E27 cap; refer to **Art. Meccanocar: 3480000100 and 3480000200.**

Code	Description	Attachment	Power <i>Led / tradit.</i>	Voltage <i>(V)</i>	Lum. flow	Dimensions	Temp. <i>colour light</i>	Current
5180000110	Light bulb 12/24v-E27	E27	12w / 75w	12/24v	1055lm, 270°	Ø60, 119mm	4000K Neutral L.	470mA



## EXCELSIOR light bulb - LED



**E40** Do not install on closed or poorly ventilated appliances

- “Il massimo dell’eccellenza”, lampada High Power con attacco industriale E40, prodotto professionale, semplice e veloce da installare; estremamente adatta per applicazioni in sospensione industriali aperte, in sostituzione dei riflettori industriali o “cappelloni” con lampade a scarica tradizionale (SAP) da 200/500w.
- Prestare molta attenzione a non installare questo tipo di lampada su apparecchi chiusi o con scarsa aereazione.
- Svitare la vecchia lampada a scarica tradizionale e riavvitare quella nuova a Led, controllando preventivamente che le due lampade funzionino alla stessa tensione di alimentazione e che l’attacco sia il medesimo.
- L’accensione è immediata come il risparmio di energia elettrica, già dalle prime bollette. Per poter beneficiare di un ulteriore risparmio energetico, si consiglia di sostituire tutte le lampade presenti sull’impianto elettrico con quelle nuove a Led.

Code	Description	Attachment	Power <i>Led / tradit.</i>	Voltage <i>(V)</i>	Lum. flow	Dimensions	Temp. <i>colour light</i>	Current
5180000280	Excelsior 70w-230-6500K-E40	E40	70w/500w	175/250v	7000lm, 200°	Ø88, 168mm	6500K Cold L.	338mA
5180000290	Excelsior 100w-230-6500K-E40	E40	100w/750w	175/250v	10000lm, 200°	Ø98, 187mm	6500K Cold L.	483mA
5180000300	Excelsior 150w-230-6500K-E40	E40	150w/1000w	175/250v	15000lm, 270°	Ø114, 230mm	6500K Cold L.	725mA

## T8 LED tube



- Il tubo a Led T8 ha la stessa forma delle lampade fluorescenti lineari perciò è molto semplice da sostituire. Costituito da diodi Led, può emettere luce bianca o gialla a seconda dei vari tipi di impiego. La sua applicazione è sempre più richiesta per illuminare uffici, aree commerciali, locali ad alta precisione, studi tecnici, saloni, corridoi, banchi da lavoro, punti vendita e zone che necessitano di una luce intensa per un tempo prolungato contenendo i consumi di energia elettrica.
- I principali vantaggi: durata 3 volte superiore a tutte le altre tecnologie alogene o fluorescenti, garantiscono fino al 70% di risparmio energetico, grazie al fatto che un led da soli 6W può sostituire una lampada tradizionale da 60W. Generano un fascio luminoso di altissima qualità con potenze di funzionamento/assorbimento nettamente minori, mantenendo una resa cromatica CRI>80. Accensione immediata come il risparmio di energia elettrica, già dalle prime bollette.
- L'installazione è semplice e veloce: togliere il vecchio tubo e sostituire lo starter tradizionale con quello a led, compreso nella confezione e rimontare il nuovo tubo Led. Nel caso in cui la plafoniera fosse dotata di un trasformatore da 220v a 12v, occorrerà rimuoverlo e ricollegare i fili direttamente allo starter in dotazione.
- Struttura in vetro opale con grado di protezione IP20, capace di sopportare temperature d'esercizio da -40°C a +50°C. Totalmente privo di mercurio e di altri metalli pesanti. Non necessita di alcuna manutenzione, emette luce sicura senza raggi infrarossi o ultravioletti. Tutti i nostri prodotti sono certificati con classificazione energetica A+. Per poter beneficiare di un maggior risparmio energetico, si consiglia di sostituire tutti i tubi presenti sull'impianto con quelli con nuova tecnologia a Led.
- Prodotto professionale facile e veloce da installare, abbinabile a qualsiasi plafoniera con vecchia tecnologia a neon o fluorescente. Fornito in speciale packaging idoneo per la spedizione al fine di tutelare l'integrità del prodotto.

Code	Description	Attachment	Power <i>Led / tradit.</i>	Voltage <i>(V)</i>	Lum. flow	Dimensions	Temp. <i>colour light</i>	Current
5180000010	LED tube 10w-600-4000K	G13	10w/18w CFL	230v	900lm, 300°	Ø25.4, 600mm	4000K natural L.	43mA
5180000020	LED tube 10w-600-6500K	G13	10w/18w CFL	230v	900lm, 300°	Ø25.4, 600mm	6500K Cold L.	43mA
5180000021	Tubo led 14W-900-4000K*	G13	14w/30w CFL	220-240v	1400lm, 270°	Ø25, 900mm	4000K natural L.	70mA
5180000022	Tubo led 14W-900-6500K*	G13	14w/30w CFL	220-240v	1400lm, 270°	Ø25, 900mm	6500K Cold L.	70mA
5180000030	Tubo Led 18w-1200-4000K	G13	18w/36w CFL	230v	1800lm, 300°	Ø25.4, 1200mm	4000K L.naturale	80mA
5180000040	Tubo Led 18w-1200-6500K	G13	18w/36w CFL	230v	1800lm, 300°	Ø25.4, 1200mm	6500K L.fredda	80mA
5180000050	Tubo Led 18w-1500-4000K	G13	22w/58w CFL	230v	2200lm, 300°	Ø25.4, 1500mm	4000K L.naturale	105mA
5180000060	Tubo Led 18w-1500-6500K	G13	22w/58w CFL	230v	2200lm, 300°	Ø25.4, 1500mm	4000K L.fredda	105mA

## IP65 protection rating, anti-corrosive fittings - LED

3

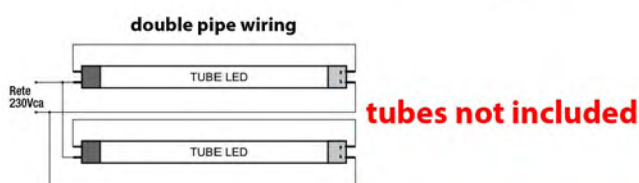

- Rectangular, anti-corrosive LED fittings, suitable for housing two x T8 LED tubes (not included) of 18w or 22w each, depending upon the length of the fitting. Ideal for substituting conventional 40/60w fluorescent fittings. Its characteristics makes it ideal for illuminating work areas, such as workshops, warehouses, factories, car parks and tunnels or large work areas.
- The structure is in self-extinguishing polycarbonate with power feed entering from one side, sealed, resistant to water, dust and corrosion. IP65 protection rating and IK08 protection against impact. It emits a luminous, uniform, direct beam and is not affected by sudden changes of the temperature, it does not need maintenance and does not emit heat.
- The installation is simple and quick with the possibility of fixing it to the wall or by gravity. The substitution of the tubes is rapid, thanks to the rapid release mechanism of the compartment.
- Our complete range of products is certified to energy class A+. Furthermore, in order to make greater energy saving, it is recommended to change all fittings of the electrical system to the new LED fittings.
- **Insertable tubes:**
  - "18w-1200-4000K LED tube" Mecc code: 5180000030
  - "18w-1200-6500K LED tube" Mecc code: 5180000040
  - "22w-1500-4000K LED tube" Mecc code: 5180000050
  - "22w-1500-6500K LED tube" Mecc code: 5180000060

Code	Description	Power <i>Led / tradit.</i>	Dimension <i>Width. x Lung. x Alt.</i>
5180000070	LED fitting IP65 2x18w-1200	36w - 220/230v	99x1260x78 mm
5180000080	LED fitting IP65 2x22w-1500	44w - 220/230v	99x1560x78 mm

## 600x600 standard LED panel IP40



- High luminosity LED panel. Ideal for application in plasterboard panel false ceilings or suspended ceilings. Ideal for substituting 100W fluorescent fittings. The standard LED panel will allow you to enter into a new visual dimension made up of brilliant colours, homogeneity of light and unequalled aesthetic aspect. It will further allow the operators less eye strain.
- Innovative, slim design and it lasts 3 times longer than all other halogen and fluorescent technologies. It guarantees a net energy saving by generating a much more intense luminous beam with a clearly less functioning power/absorption. Its working life is estimated at more than 30,000 hours.
- Supplied with an IP40 protection rating power charger with anti-dazzle optics and no UV or IR rays (dazzle coefficient **UGR<19**). A professional product, easy and quick to install. Lift and remove the plasterboard panel, connect the power charger to the electricity mains and place the LED panel on the aluminium frame profile that before supported the old plasterboard panel.
- Switching on is immediate, as is the saving of electrical energy that starts right from the first invoice. Our complete range of products is certified to energy class A+. Furthermore, in order to make greater energy saving, it is recommended to change all fluorescent fittings of the electrical system to the new LED light panels.

Code	Description	Power <i>Led / tradit.</i>	Voltage <i>(V)</i>	Lum. flow	Dimensioni <i>LxLxSpess.</i>	Temp. <i>colour light</i>	Current
5180000090	LED panel 600x600 IP40	42w / 100w CFL	200/240v	3680lm, 120°	595x595x10 mm	4000K Neutral L.	200mA

## 300x1200 LED panel IP43



- Pannello rettangolare a Led ad alta luminosità. Ideale per applicazioni su controsoffittature a pannelli in cartongesso o a sospensione; sostituibile alle plafoniere a tubi fluorescenti da 100w. Il pannello standard a Led vi permetterà di entrare in una nuova dimensione visiva, fatta di colori brillanti, omogeneità di luce ed aspetto estetico ineguagliabile; permettendo inoltre agli operatori stessi di sforzare meno la vista.
- Design innovativo e sottile, durata 3 volte superiore a tutte le altre tecnologie alogene o fluorescenti, garantisce un netto risparmio energetico, riuscendo a generare un fascio luminoso molto più intenso, con potenze di funzionamento/assorbimento nettamente minori. Il suo funzionamento è stimato per oltre 30.000h.
- Fornito con alimentatore, grado di protezione IP40, ottica anti abbaglio e assenza di raggi UV o IR (coefficiente di abbagliamento UGR<19). Prodotto professionale, facile e veloce da installare. Sollevare e rimuovere il pannello in cartongesso, collegare l'alimentatore alla linea elettrica ed appoggiare il pannello Led sulla profilatura in alluminio, che prima sosteneva il vecchio pannello di cartongesso.
- L'accensione è immediata come il risparmio di energia elettrica, che si ha già dalle prime bollette. Tutta la nostra gamma di prodotti è certificata con classificazione energetica A+. Per poter beneficiare di un ulteriore maggior risparmio energetico, si consiglia di sostituire tutte le plafoniere presenti sull'impianto elettrico con quelle nuove a Led.

Code	Description	Power <i>Led / tradit.</i>	Voltage <i>(V)</i>	Lum. flow	Dimensioni <i>LxLxSpess.</i>	Temp. <i>colour light</i>	Current
5180000100	LED panel 300x1200 IP43	42w / 100w CFL	200/220v	3900lm, 120°	1195x295x10mm	4000K Neutral L.	200mA

## Adjustable Flat LED Projector lamp

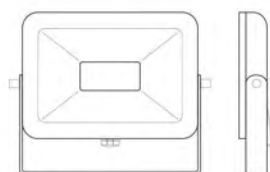

- Adjustable LED projector lamp that can be adjusted to various angles with an aluminium die cast body finished in white. The highly reflective reflector is protected by tempered glass. Ideal for wall and ground application. It substitutes traditional 75w halogen projector lamps. Suitable for internal and external installation. This generation of LED projector lamps will allow you to enter into a new visual dimension made up of brilliant colours, homogeneity of light and unequalled aesthetic aspect.
- Innovative, slim design and it lasts 3 times longer than all other halogen and fluorescent technologies. It guarantees a net energy saving by generating a much more intense luminous beam with a clearly less functioning power/absorption. Its working life is estimated at more than 30,000 hours with a CRI>80 chromatic yield and IP65 protection rating. Supplied with a 1 metre long silicone power cable. Our complete range of products is certified to energy class A+.
- A professional product, easy and quick to install. Switching on is immediate, as is the saving of electrical energy that starts right from the first invoice. Furthermore, in order to make greater energy saving, it is recommended to change all projector lamps of the electrical system to the new LED projector lamps.

Code	Description	Power <i>Led / tradit.</i>	Voltage <i>(V)</i>	Lum. flow	Dimensioni <i>Larg.xSpes.xAlt.</i>	Temp. <i>colour light</i>	Current
5180000330	10w adjustable flat projector lamp	10w / 75w Halogen	195/265v	800lm, 120°	150x26x130mm	3000K Warm L.	75mA

## LED Plus projector lamps

3



- LED projector lamp with an age-resistant PVC body, highly reflective, ashlar-finished reflector painted black, with anti-dazzle, opal glass and plate in pure, high heat-dissipation aluminium. Ideal for internal and external wall application. It substitutes traditional 200/300/400w halogen projector lamps. This generation of LED projector lamps will allow you to enter into a new visual dimension made up of brilliant colours, homogeneity of light and unequalled aesthetic aspect.
- Innovative, slim design and it lasts 3 times longer than all other halogen and fluorescent technologies. It guarantees a net energy saving by generating a much more intense luminous beam with a clearly less functioning power/absorption. Its working life is estimated at more than 30,000 hours with a CRI>80 chromatic yield and IP65 protection rating. Supplied with a 50 cm power cable. Our complete range of products is certified to energy class A+.
- A professional product, easy and quick to install. Switching on is immediate, as is the saving of electrical energy that starts right from the first invoice. Furthermore, in order to make greater energy saving, it is recommended to change all projector lamps of the electrical system to the new LED projector lamps.

Code	Description	Power <i>Led / tradit.</i>	Voltage <i>(V)</i>	Lum. flow	Dimensioni <i>Larg.xSpes.xAlt.</i>	Temp. <i>colour light</i>	Current
5180000340	LED Plus projector lamps 20w	20w / 200w Halogen	180/240v	1600lm, 120°	166x67x167mm	4000K L. neutral	100mA
5180000350	LED Plus projector lamps 30w	30w / 300w Halogen	100/240v	3000lm, 120°	166x67x167mm	4000K L. neutral	150mA
5180000360	LED Plus projector lamps 50w	50w / 400w Halogen	100/240v	5000lm, 120°	220x79x214mm	4000K L. neutral	200mA

## Projecteurs Advance – LED



- The Advance Led projector lamp, with a 1060 aluminium die cast body finished in black, with Heat Pipe dissipation technology. Ideal for internal and external wall application. It substitutes traditional 800-1000w halogen projector lamps. This generation of LED projector lamps will allow you to enter into a new visual dimension made up of brilliant colours, homogeneity of light and unequalled aesthetic aspect.
- Corrosion-resistant body finished in electrophoresis paint, It lasts 3 times longer than all other halogen and fluorescent technologies and guarantees a net energy saving by generating a much more intense luminous beam with a clearly less functioning power/absorption. Its working life is estimated at more than 40,000 hours with a CRI>80 chromatic yield and IP65 protection rating. Our complete range of products is certified to energy class A+.
- A professional product, easy and quick to install. Switching on is immediate, as is the saving of electrical energy that starts right from the first invoice. Furthermore, in order to make greater energy saving, it is recommended to change all projector lamps of the electrical system to the new LED projector lamps.

Code	Description	Power <i>Led / tradit.</i>	Voltage <i>(V)</i>	Lum. flow	Dimensioni <i>Larg.xSpes.xAlt.</i>	Temp. <i>colour light</i>	Current
5180000370	Advance projector lamp 100w	100w/800w Halog.	195/265v	10500lm, 120°	267x143x309mm	4000K neutral L.	500mA
5180000380	Advance projector lamp 150w	150w/1000w Halog.	195/265v	15750lm, 120°	298x186x364mm	4000K neutral L.	900mA



## LED Shuttle projector lamps



**SAFETY SENSOR  
CREPUSCULAR**  
the projector only activates  
when detecting presence in low  
brightness conditions

- Ultra-slim LED projector lamp with a heavy aluminium body finishes in epoxy grey paint, with tempered glass. Ideal for internal and external wall application. It substitutes traditional 300/400w halogen projector lamps. This generation of LED projector lamps will allow you to enter into a new visual dimension made up of brilliant colours, homogeneity of light and unequalled aesthetic aspect.
- Innovative, slim design and it lasts 3 times longer than all other halogen and fluorescent technologies. It guarantees a net energy saving by generating a much more intense luminous beam with a clearly less functioning power/absorption. Its working life is estimated at more than 30,000 hours with a CRI>80 chromatic yield and IP65 protection rating. Our complete range of products is certified to energy class A+.
- It switches on automatically when people pass by and when the light is less than 20 lux (sunset). The projector lamp remains on for 3 minutes at maximum intensity before eventually switching off automatically.
- A professional product, easy and quick to install. Switching on is immediate, as is the saving of electrical energy that starts right from the first invoice. Furthermore, in order to make greater energy saving, it is recommended to change all projector lamps of the electrical system to the new LED projector lamps.

Code	Description	Power <i>Led / tradit.</i>	Voltage <i>(V)</i>	Lum. flow	Dimensioni <i>Larg.xSpes.xAlt.</i>	Temp. <i>colour light</i>	Current
5180000390	Shuttle projector lamp 30w	30w / 300w Halogen	195/265v	2240lm, 120°	150x53x120mm	4000K neutral L.	133mA
5180000400	Shuttle projector lamp 50w	50w / 400w Halogen	195/265v	3450lm, 120°	188x59x145mm	4000K neutral L.	226mA

## Alkaline batteries X-Power



- Alkaline batteries.
- Ideal for any application.
- They provide reliable performance and long life in a wide range of everyday devices.
- Not rechargeable.



Code	Desc.	Voltage (V)	Diam. mm	Height mm	Weight gr.	Model	Dimensions
5120001000	350-LR20	1,5	34,2	60,0	140,6	Torch	D
5120001010	355-LR14	1,5	25,4	50,0	67,4	1/2 torch	C
5120001020	360-LR6	1,5	14,1	50,5	23,1	Stylus	AA
5120001030	365-LR03	1,5	10,5	44,5	11,4	Penlight	AAA
5120001040	370-6LF22	9	17,5X26,5	48,5	46,1	Transistor	9V

## Extreme Lithium batteries



- Lithium batteries.
- Designed for discerning customers who demand the most from their battery powered devices.
- Ideal for the most varied applications, guarantee performance and a longer life than regular alkaline batteries.
- 700% more energy.
- Weighing less than 30% than alkaline batteries.
- not rechargeable



Code	Desc.	Model	Dimensions	Voltage (V)	Height mm	Diam. mm	Weight gr.
5120001200	500 - FR6	Stylus	AA	1,5	50,5	14,1	15,4
5120001210	505 - FR03 M	Penlight	AAA	1,5	44,5	10,5	7,2

## Batteries for remote controls

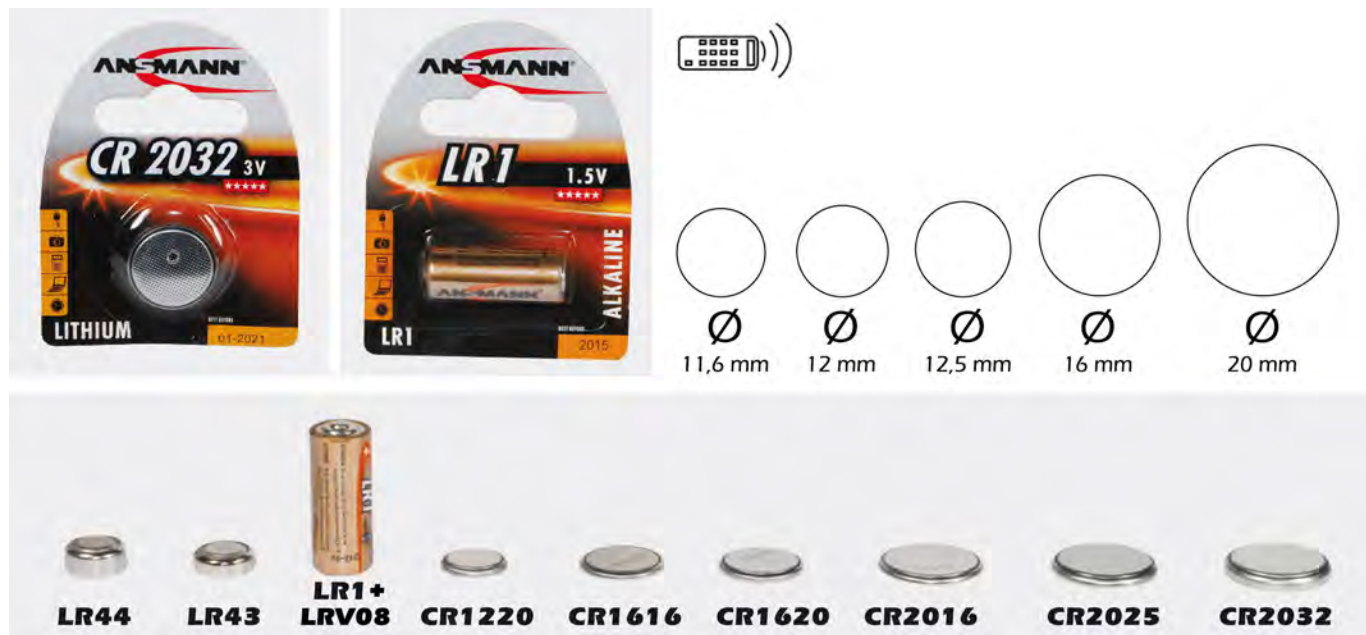

3

- Stacks of high quality to feed electrical devices including remote controls, watches, calculators, computers and other applications.
- Ensure reliable performance and long life.

Code	Desc.	Voltage (V)	Height mm	Diam. mm	Weight gr.	Type	Capacity (mAh)
5120001050	375 - LR44	1,5	5,4	11,6	2	Alcaline	115
5120001060	380 - LR43	1,5	4,2	11,6	1,6	Alcaline	75
5120001070	385 - LR1	1,5	30,2	12,0	9,2	Alcaline	/
5120000250	250 - LRV08	12	28,9	10,3	6	Alcaline	33
5120001080	390 - CR1220	3	2,0	12,5	0,9	Litio	40
5120001090	395 - CR1616	3	1,6	16,0	1,2	Litio	50
5120001100	400 - CR1620	3	2,0	16,0	1,3	Litio	70
5120001110	405 - CR2016	3	1,6	20,0	1,7	Litio	75
5120001120	410 - CR2025	3	2,5	20,0	2,5	Lithium	150
5120001130	415 - CR2032	3	3,2	20,0	3,3	Lithium	210

## Rechargeable batteries Ni MH Professional



- Rechargeable batteries supplied preloaded in sizes AA, AAA and 9V transistor.
- Long duration.
- Able to hold a charge for one year without use up to 80%.
- Recommended for apparecchiature high absorption.
- We recommend the use of our battery charger Powerline 4 (512 00 00500) or powerline 5 (512 00 00600).

Code	Desc.	Model	Dimensions	Voltage (V)	Capacity (mAh)	Height mm	Diam. mm	Weight gr.
5120000320	320-RC01	Stylus	AA	1.2	2500	50.5	14.5	27,5
5120000325	325-RC02	Stylus	AAA	1.2	800	44.5	10.5	12
5120000330	330-RC03	transistor	9V	9	250	48.5	16x26.5	41,5

## Professional Charger Powerline 4



- Professional charger for rechargeable AA and AAA.
- Supplied with 4 AA style batteries.
- It can power both in-100-240V AC and 12V-DC cigarette lighter with special connector supplied as standard.
- Releases automatically from the network as soon as the batteries are fully charged.
- Monitoring of individual charging compartments.
- Multiple protection against overload.
- Recognition alkaline batteries and defective.



Tipo	Capacità	Tempo di ricarica
<b>Stilo AA</b>	2500mAh/maxE+	3.5 h
/	2100mAh	3 h
/	1000mAh	1.5 h
<b>Mini Stilo AAA</b>	1000mAh	3 h
/	800mAh	2.5 h
/	500mAh	1.5 h

Code	Desc.
5120000500	PW500

## Professional charger Powerline 5



- Professional charger for AA rechargeable batteries, AAA, D torches, mezzetorce C, 9V transistor.
- Supply 100-240V AC.
- It automatically disconnects as soon as the batteries are fully charged.
- Display charge status through LCD and LED.
- Monitoring of individual charging rooms.
- For cylindrical cells: multiple overload protection, recognition defective and alkaline batteries.

Tipo	Capacità	Tempo di ricarica
<b>MiniStilo</b>	800mAh	2h
/	1000mAh	2.5h
<b>Stilo AA</b>	2100mAh	2.5h
/	2700mAh	3h
<b>MezzaTorce C</b>	3000mAh	3.5h
/	4500mAh	5.5h
<b>Torce D</b>	8000mAh	10h
/	10000mAh	12h
<b>Transistor 9V</b>	120mAh	10h
/	250mAh	20h

Code	Desc.
5120000600	PW600

## 6V Battery for lamps



- Battery for our lamps art. 08022- 446 446 00 00 09500-446 00 08023-446 00 09505.

Code	Desc.
4460008021	4038/1









## Taglio, foratura e abrasivi

Lame per macchine fisse e portatili . . . . .	pag. 426	Cutter, coltelli raschiati . . . . .	pag. 492
Lame per seghetti a mano . . . . .	pag. 431	Dischi da taglio e smeriglio. . . . .	pag. 499
Punte pantografo e frese in HSS . . . . .	pag. 448	Dischi lamellari, tele e carte abrasive. . . . .	pag. 506
Punte per trapani e martelli elettropneumatici . . . . .	pag. 450	Spazzole in acciaio a macchina e a mano. . . . .	pag. 525
Frese a tazza in HSS e bimetalliche. . . . .	pag. 468	Dischi velcrati e tamponi per lucidatura . . . . .	pag. 533
Maschi, filiere, svasatori, punte coniche e a gradino . . . . .	pag. 473	Dischi per decapaggio . . . . .	pag. 551
Taglio e foratura al diamante . . . . .	pag. 489	Lime . . . . .	pag. 554

## Band saws bimetallic Special Profiles for manual and automatic saws



- Bimetallic strip steel M42-CO9%.
- Intended Use: metallic carpentry, blacksmithing, joinery.
- For use on all types of steels, stainless steel, iron. Especially suitable to make cuts of profiles built with very hard steel.
- Form and type of toothing specially designed for cutting of beams, pipes, bundles of tubes, molded case, angular profiles, irons "L" irons "T".
- Joints free from jump teeth for greater resistance to stress.
- Compared to traditional band saws, the special profil offer greater durability, quiet operation, and cutting speed.

4

### TIPI DI LAVORAZIONI RACCOMANDATE



\*\*\*\* MISURE E CODICI FARE RIFERIMENTO AL LISTINO

### SCELTA DELLA DENTATURA PER OGNI TIPO DI SPESSORE

TIPO DI DENTATURA	SPESSORE PROFILATO DA TAGLAIRE MM
8/11	DA 1,5 A 4,0
5/7	DA 4,0 A 12,0

Code	Description <i>Development x height x thickness</i>
495SP*****	*** X ** X ***

## Band saws bimetallic Saw manual and automatic



- Bimetallic strip steel M42-CO9%.
- Intended Use: metallic carpentry, blacksmithing, joinery.
- For use on all types of steels, stainless steel, iron.
- Form and type of toothing specially designed for cutting of beams, pipes, bundles of tubes, molded case, angular profiles, irons "L" irons "T", and solid material.
- Joints free from jump teeth for greater resistance to stress.

### TIPI DI LAVORAZIONI RACCOMANDATE



\*\*\*\* MISURE E CODICI FARE RIFERIMENTO AL LISTINO

Code	Description <i>Development x height x thickness</i>
4950*****	*** X ** X ***



## Indicazioni d'uso seghe a nastro Meccanocar

PER MIGLIORARE LE PRESTAZIONI SIA DI TAGLIO CHE DI DURATA DELLE SEGHE A NASTRO BIMETALLICHE MECCANOCAR, SI CONSIGLIA DI SEGUIRE LE INDICAZIONI SOTTO RIPORTATE.

### ● MACCHINA

Verificare frequentemente: la funzionalità delle spazzole, usura e allineamento delle guide, tensione del nastro con tensiometro, velocità del nastro con tachimetro, concentrazione del refrigerante con rifrattometro.

### ● REFRIGERANTE OD OLIO DA TAGLIO

Il refrigerante lubrifica, raffredda ed asporta il truciolo da taglio. Utilizzare refrigeranti di buona qualità, si consiglia il nostro codice 411 00 14860-2784 lt. 5 e 411 00 19315-5950 lt. 20. Usare la concentrazione del refrigerante consigliata. Assicurarsi che il refrigerante arrivi al taglio a bassa pressione e con un flusso abbondante.

### ● PEZZO DA LAVORARE

Assicurarsi che il pezzo da tagliare sia solidamente bloccato e che non possa vibrare o ruotare.

### ● RODAGGIO DELLA NUOVA LAMA

All'inizio del taglio usare sempre la velocità consigliata riducendo l'avanzamento ad 1/3 o 1/2 per i primi 10 minuti di lavoro, successivamente aumentare gradatamente l'avanzamento fino al valore consigliato.

### ● DENTATURA

La scelta del passo dei denti deve essere fatta in proporzione dello spessore da tagliare.

**DURANTE LA FASE DI TAGLIO, POSSONO SORGERE ALCUNE PROBLEMATICHE, RIPORTIAMO LE PIU' COMUNI E LE EVENTUALI CAUSE DA CUI POSSONO DERIVARE.**

### ● ROTTURA DEI DENTI

Velocità di avanzamento eccessiva. La dentatura scelta per il taglio non è idonea. Il pezzo da lavorare non è stato bloccato. I trucioli hanno otturato gli spazi tra i denti. Non c'è abbastanza flusso dell'emulsione. La saldatura è difettosa.

### ● ROTTURA DEL NASTRO

Velocità di avanzamento eccessiva. La tensione del nastro è eccessiva. La dentatura scelta per il taglio non è idonea. Le guide sono usurate. La saldatura è difettosa.

### ● TAGLIO NON PRECISO

I denti sono usurati. Il nastro non ha subito un rodaggio corretto. La velocità della macchina è troppo bassa. L'avanzamento è troppo veloce. La tensione del nastro è insufficiente. Le guide delle lame non sono allineate o sono danneggiate.

### ● CONSUMO ECCESSIVO DEI DENTI

Velocità della macchina eccessiva. Il nastro non ha subito un rodaggio corretto. Refrigerazione non sufficiente. La superficie del pezzo presenta delle irregolarità.

### ● ECCESSIVE VIBRAZIONI

La tensione del nastro è troppo bassa. Velocità di avanzamento del nastro eccessiva. Il nastro non ha subito un rodaggio corretto.

4

## Lame circolari per alluminio

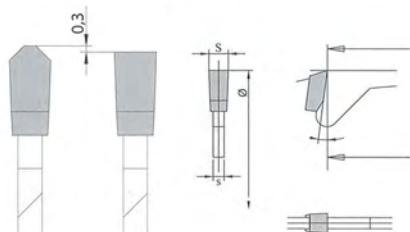

- Lame a dentatura positiva per il taglio di profilati in alluminio, materiali non ferrosi, resine e plastiche. Esecuzione non silenziosa.
- La dentatura positiva permette l'avanzamento automatico del pezzo lavorato, dentatura saldata al laser in metallo duro, massima silenziosità di utilizzo ed assenza di sbavature sia in entrata sia in uscita.
- Perfettamente equilibrati, diametri superiori a 400 mm dotati di rivetto in rame per l'espansione del materiale durante la lavorazione, disponibili con diversi diametri di foro interno.

Code	Desc.	Ø mm	N. teeth	Ø foro centrale mm
5100000200	300G	300	96	32
5100000250	300P	300	96	30
5100000300	350G	350	108	32
5100000350	350P	350	108	30
5100000400	400G	400	120	32
5100000450	400P	400	120	30
5100000500	450G	450	128	32
5100000550	450P	450	128	30
5100000600	500G	500	120	32
5100000650	500P	500	120	30

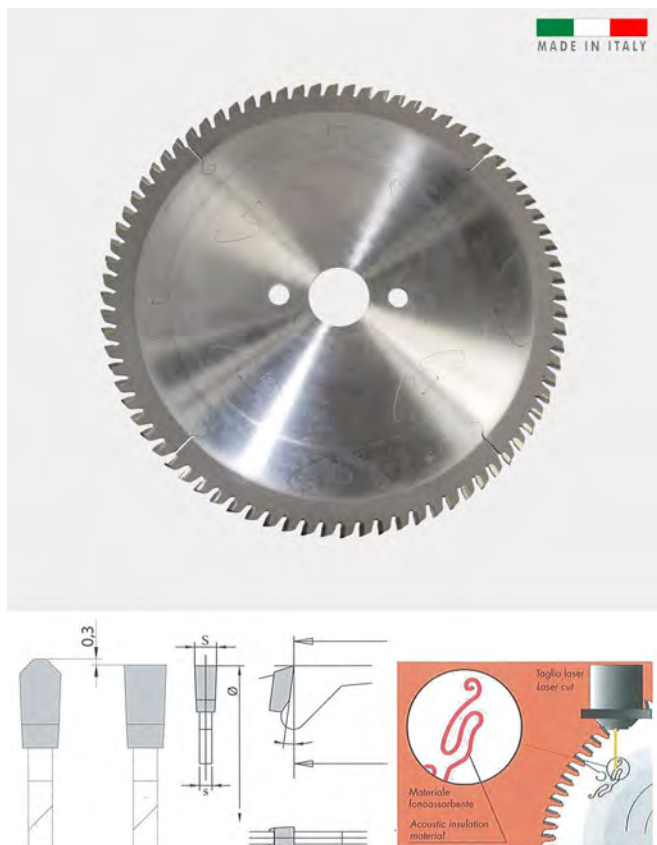
**Lame circolari silenziate per alluminio**

- Lame a dentatura positiva per il taglio di profilati in alluminio, materiali non ferrosi, resine e plastiche. Esecuzione silenziata.
- La dentatura positiva permette l'avanzamento automatico del pezzo lavorato, dentatura saldata al laser in metallo duro, massima silenziosità di utilizzo ed assenza di sbavature sia in entrata sia in uscita.
- Perfettamente equilibrati, intagli di silenziamento sagomati al laser e riempiti di materiale fonoassorbente e smorzatore di vibrazioni, disponibili con diversi diametri di foro interno.

Code	Desc.	Ø mm	N. teeth	Ø foro centrale mm
5100001600	300SG	300	96	32
5100001650	300SP	300	96	30
5100001700	350SG	350	108	32
5100001750	350SP	350	108	30
5100001800	400SG	400	120	32
5100001850	400SP	400	120	30
5100001900	450SG	450	128	32
5100001950	450SP	450	128	30
5100002000	500SG	500	120	32
5100002050	500SP	500	120	30

**Lame circolari per PVC**

- Lame a dentatura positiva per il taglio di profilati PVC. Esecuzione non silenziata.
- La dentatura positiva permette l'avanzamento automatico del pezzo lavorato, dentatura saldata al laser in metallo duro, massima silenziosità di utilizzo ed assenza di sbavature sia in entrata sia in uscita.
- Perfettamente equilibrati, diametri superiori a 400 mm dotati di rivetto in rame per l'espansione del materiale durante la lavorazione, disponibili con diversi diametri di foro interno.

Code	Desc.	Ø mm	N. teeth	Ø foro centrale mm
5100002500	300PG	300	96	32
5100002510	300PP	300	96	30
5100002520	350PG	350	108	32
5100002530	350PP	350	108	30
5100002540	400PG	400	120	32
5100002550	400PP	400	120	30
5100002560	450PG	450	128	32
5100002570	450PP	450	128	30
5100002580	500PG	500	120	32
5100002590	500PP	500	120	30



## Frese pantografo in HHS 8% Co – Alluminio e PVC

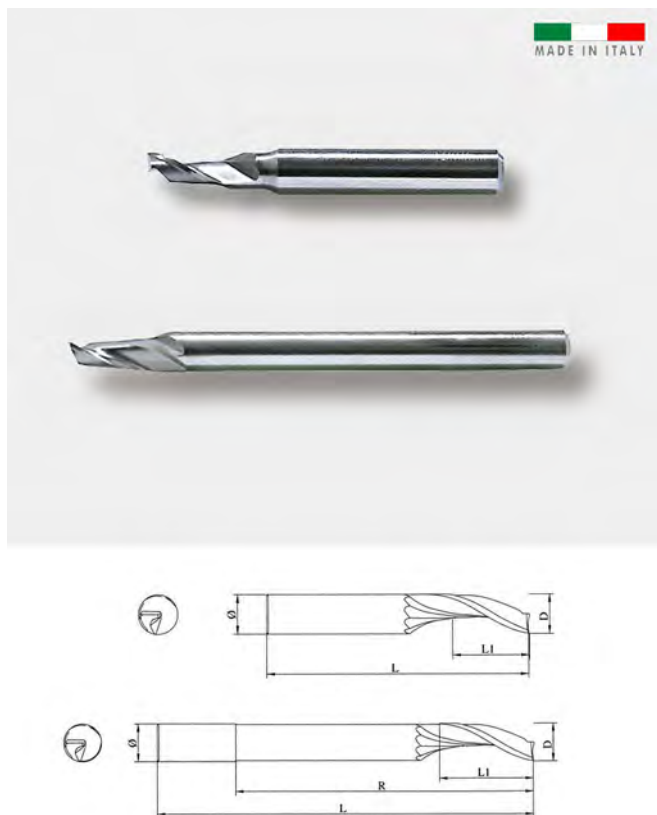

- Frese a elica destra singola per lavorazioni su profilati in alluminio, PVC e materiali non ferrosi, realizzate in acciaio HSS all'8% di cobalto.
- Indicate per lavorazioni su pantografi manuali, automatici e macchine cnc, attacco universale cilindrico nei diametri più usati.
- Disponibili nelle serie corta, lunga ed extra lunga.

Code	Desc.	D mm	L1 mm	R mm	L mm	Ø mm	Model
4430049695	961/5	5	12	-	60	6	Serie corta
4430049696	961/5.1	5	14	-	60	8	Serie corta
4430049697	961/5.2	5	12	-	60	10	Serie corta
4430049699	961/6	6	12	-	60	6	Serie corta
4430049700	961/6.1	6	14	-	60	8	Serie corta
4430049701	961/6.2	6	12	-	60	10	Serie corta
4430049705	961/8	8	18	-	80	8	Serie corta
4430049710	961/10	10	14	-	80	8	Serie corta
4430049711	961/10.1	10	18	-	80	10	Serie corta
4430049715	962/5	5	16	45	90	8	Serie lunga
4430049716	962/5.1	5	18	33	100	8	Serie lunga
4430049717	962/5.2	5	14	33	120	8	S.extra lunga
4430049720	962/6	6	14	45	90	8	Serie lunga
4430049727	962/6.1	6	14	33	100	8	Serie lunga
4430049725	962/8	8	15	70	100	8	Serie lunga
4430049726	962/8.1	8	14	90	120	8	S.extra lunga
4430049730	962/10	10	14	45	80	10	Serie lunga
4430049731	962/10.1	10	20	70	100	10	Serie lunga
4430049732	962/10.2	10	14	90	120	10	S.extra lunga

## Frese pantografo in HHS 8% Co per PVC



- Frese a elica destra singola per lavorazioni su profilati in PVC, realizzate in acciaio HSS all'8% di cobalto. Misure specifiche per la realizzazione degli scarichi condensa.
- Indicate per lavorazioni su pantografi manuali, automatici e macchine cnc, attacco universale cilindrico nei diametri più usati.

Code	Desc.	D mm	L1 mm	L mm	Ø mm
4430057610	1772/5	5	35	80	8
4430057620	1772/5.1	5	40	100	8
4430057630	1772/6	6	40	100	8
4430057640	1772/8	8	40	120	8

## Punte a doppio foro in HSS 8% Co



- Punte a doppio foro per foratrici, per l'utilizzo su tutti i metalli e PVC.
- Esecuzione in acciaio HSS all'8% di cobalto.
- Ideali per creare le sedi testa vite e distanziali su infissi in alluminio e PVC.

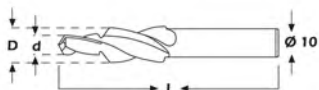

Code	Desc.	d mm	D mm	l. mm
4430049735	963-5/11 mm	5.5	11,5	100
4430049740	963-6/12 mm	6	12	100
4430049745	963-7/14 mm	7	14	100
4430049750	963-7/15 mm	7	15	100
4430049755	963-7/22 mm	7	22,5	100

4

## Discs HSS-DMo5 for parting machines

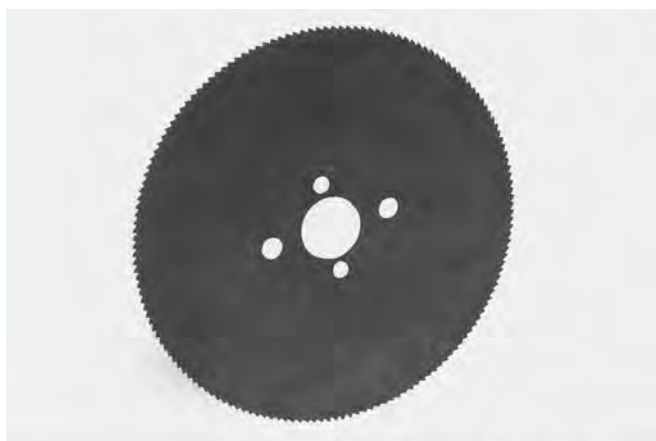

- HSS-DMo5 running "steam" treatment that completely envelops the tool coming as well in the layers more 'deep determining: high resistance to seizing, high degree of retention of the coolant, the absence of tension in the saw, high value of structural strength.
- For cutting steel (up to 1000 n / mm<sup>2</sup>), stainless steel and non-ferrous materials.
- WARNING: We recommend the use of cutting oil for lubrication and cooling Meccanocar emulsion art. cod. 411 00 14860 to 2784 Lt 5.

### Attacco

PASSO X MATERIALE  
T 4 = PROFILATO  
T 5 = PIENO PROFILATO  
T 6 = PIENO

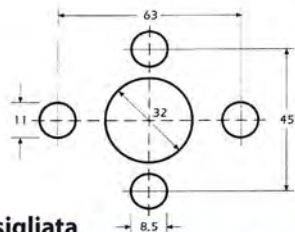

### Velocità di taglio (N° giri) consigliata

RESISTENZA MATERIALE	VELOCITA' PERIFERICA	V=VELOCITA' PERIFERICA m/min RAPPORATATO ALLA RESISTENZA DEL MATERIALE	V = $\frac{\pi \times 3,14 \times n}{1000}$
50 Kg/mm <sup>2</sup>	25-50 m/min	n= NUMERO GIRI AL MINUTO	n = $\frac{\pi \times 3,14 \times n}{1000}$
50-80 Kg/mm <sup>2</sup>	12-25 m/min		n = 100
80-100 Kg/mm <sup>2</sup>	10-15 m/min	Sz= SEZIONE DI TRUCIOLO ASPORTATA PER DENTE = mm 0,02-0,1	
ACCIAIO INOX	7-15 m/min	AVANZAMENTO AL MINUTO	n = $\frac{z \times n \times s}{2}$
OTTONE	300-700 m/min	PROFILI SOTTILI	= V x 2
RAME	20-200 m/min		
LEGHE LEGGERE	400-800 m/min		

Code	Desc.	Dim. mm	N. teeth	Step
4960000100	200 - T6	200x1,8	100	T6
4960000150	200 - T5	200x1,8	130	T5
4960000250	225 - T6	225x1,9	120	T6
4960000300	225 - T5	225x1,9	140	T5
4960000350	225 - T4	225x1,9	180	T4
4960000400	250 - T6	250x2,0	128	T6
4960000450	250 - T5	250x2,0	160	T5
4960000500	250 - T4	250x2,0	200	T4
4960000550	275 - T6	275x2,5	140	T6
4960000600	275 - T5	275x2,5	180	T5
4960000650	275 - T4	275x2,5	220	T4
4960000700	300 - T6	300x2,5	160	T6
4960000750	300 - T5	300x2,5	180	T5
4960000800	300 - T4	300x2,5	220	T4
4960000850	315 - T6	315x2,5	160	T6
4960000900	315 - T5	315x2,5	200	T5
4960000950	315 - T4	315x2,5	240	T4

## HSS hacksaw blade for manual



- Flexible blade, high tensile strength recommended for all materials difficult.
- For use with saws type n / s art. 443 00 12500-222.

Code	Desc.	Dimens. (mm)	Teeth per inch
3220000200	35	300 X 13 X 0,65	24

## HSS bi-metal blade for hacksaw manual



- Flexible blade and shatterproof for cutting steel in general, iron and all metals.
- For use with saws type n / s art. 443 00 12500-222.

Code	Desc.	Dimens. (mm)	Teeth per inch
3220000300	36	300 X 13 X 0,65	24

## Cobalt hacksaw blade for manual



- Blade flexible and unbreakable.
- Fine tothing for stainless steel.
- For use with saws type n / s art. 443 00 12500-222.

Code	Desc.	Dimens. (mm)	Teeth per inch
3220000500	38	300 X 13 X 0,65	32

## Blade for mini bow and Puck saws

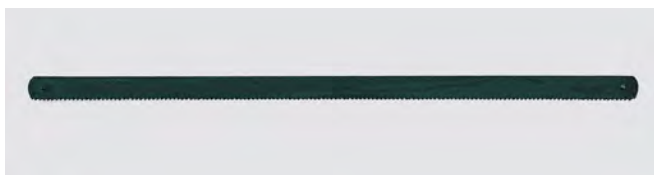

- Blade for ferrous metals in general.
- For use with saws type n / s art. 4430055750 to 1490 and all the Puck type hacksaws

Code	Desc.	L mm
3240000100	3	150

## Headband blades



- Plastic handle, body painted Blades see art. 322 00 ...
- For saw blades L. 300 mm

Code	Desc.
4430012500	222

4

## Mini headband ABS



- Mini headband ABS manual.
- Indicated for the vehicle repair industry and workshop, thermohydraulic, carpenters, electricians and window manufacturers.
- The ABS construction gives the tool strength and impact resistance.
- It equipped with ergonomic rubber grip.
- Regulation system of multiple blade: possibility 'to turn the blade up to 180°.
- System of spring tension.
- Supplied with blade.
- Suitable blades for our code 3240000100.
- Dimensions: 265 x 120 mm h.

Code	Description
4430055750	1490-Mini headband ABS

## Steel handle for hacksaw blades



- Steel handle for hacksaw blades.
- Indicated for the vehicle repair industry and workshop, termoidraulici, carpenters, electricians and window manufacturers.
- Particularly suitable for working in confined spaces.
- The steel construction gives the tool strength and impact resistance.
- Equipped with ergonomic rubber grip.
- Supplied with blade.
- Suitable for HSS blades (code 3220000200), HSS bi-metal (code 3220000300), cobalt (code 3220000500).
- Dimensions: 225 x 65 mm h max.

Code	Description
4430055755	1495-Handle for hacksaw blades

## Saw Soft Grip



- Soft Grip hand saw.
- Indicated for the vehicle repair industry and workshop, thermohydraulic, carpenters, electricians and window manufacturers.
- Particularly suitable for working in confined spaces where the margins of maneuver are minimized.
- It equipped with ergonomic soft rubber grip.
- Supplied with 2 blades.
- Suitable for universal saber saw blades, our art. cod. 417 RC ..
- Dimensions: 165 x 33 mm h.

Code	Description
4430055760	1500- Saw Soft Grip



## Series 10 blades for bimetal pneumatic saw - HSS



- Hacksaw blades for car bodies, for electrical machines or pneumatic Shimano, Chicago pneumatic etc..
- Blade length: 90 mm.

MATERIALE	DENTI X POLLICI X DIAMETRO		
	magg.> 5mm	2-2 mm	mm.< 2mm
ALLUMINIO	18	18-24	24-32
AMIANTO	18	18-24	24-32
BRONZO	18	24-32	32
EBANITE	18	18	24
RAME	18	18-24	24-32
OTTONE	18	24-32	32
PLASTICHE DURE	18	18-24	24-32
GHISA	18	18-24	24-32
ACCIAIO DOLCE	18	24	32
ACCIAIO DA COSTRUZ.			
bassolegati	18	24	32
altolegati	24	24	32
ACCIAIO DA UTENSILI			
bassolegati	18	24	32
altolegati	24	24	32
ACCIAIO HSS	18	24	32
ACCIAIO INOX	18	24	32

Code	Desc.	Teeth per inch
3220000600	39T18	18
3220000610	39T24	24
3220000620	39T32	32



## Pictogram for blades for jigsaws and saber saws



### Jigsaw blades

- Jigsaw blades, connection type Bosch.
- For each type of material, thickness and all cuttings.
- Available in various lengths for different thicknesses of materials.

### Blades for metal and other materials

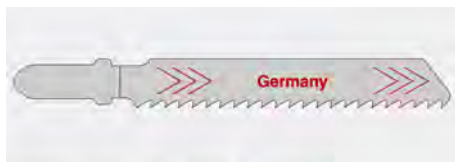

- HSS steel blade.
- Saw blade standard, wavy.
- Use for: steel up to 4 mm, stainless steel up to 3mm, non-ferrous metals and aluminum from 3 to 10 mm. Hard plastics and Plexiglas from 3 to 8 mm, and pertinax resitex. Asbestos-cement from 2 to 4mm, eternit up to 10 mm.
- \* Tpi = teeth per inch (number of teeth per inch).



Comparazione lame	
BOSCH	T 118 B
MPS	3113
AEG	254-064
METABO	23 638
WILPU	MG12

Code	Desc.	Dimensioni <i>lungh. x alt. x spes. mm</i>	Distrib. teeth <i>per mm</i>	Distrib. teeth <i>per inch</i>
417RC12250	750	77,0x7,9x1,0	2,0	13 Tpi*



Comparazione lame	
BOSCH	T 218 A
MPS	3112
AEG	254-063
METABO	23 647
WILPU	MG21

- HSS steel blade.
- Saw blade standard, wavy. Thin blade, suitable for cutting a curve.
- Use for: steel up to 2 mm, stainless steel sheets up to 2 mm, non-ferrous metals suitable for curved cuts. Suitable material for plastics reinforced with glass fibers up to 4 mm, Plexiglas up to 8 mm. Hard tissue and insulating material up to 8 mm thick.
- \* Tpi = teeth per inch (number of teeth per inch).

Code	Desc.	Dimensioni <i>lung. x alt. x spes. mm</i>	Distrib. teeth <i>per mm</i>	Distrib. teeth <i>per inch</i>
417RC12255	755	77,0x7,1x1,0	1,2	21 Tpi*



Comparazione lame	
BOSCH	T 118 A
MPS	3111
AEG	254-063
METABO	23 637
WILPU	MG11

- HSS steel blade.
- Saw blade standard, wavy. Thin blade, suitable for cutting a curve.
- For use with: steel, non-ferrous metals and aluminum up to 4 mm, stainless steel sheet up to 2 mm. Hard and soft wood up to 8 mm. Suitable for plastics reinforced with glass fibers up to 2mm. Hard tissue and Plexiglas, insulating material up to a 8 mm.
- \* Tpi = teeth per inch (number of teeth per inch).

Code	Desc.	Dimensioni <i>lung. x alt. x spes. mm</i>	Distrib. teeth <i>per mm</i>	Distrib. teeth <i>per inch</i>
417RC12260	760	77,0x7,9x1,0	1,2	21 Tpi *



Comparazione lame	
BOSCH	T 118 G
MPS	3110
AEG	274-652
METABO	23 636
WILPU	HG 107

- HSS steel blade.
- Saw blade standard, wavy. For thin sheets.
- Use for: thin sheets and profiles of less than 1mm. Steel, non-ferrous metals and aluminum up to 2 mm. Plastics armed and Plexiglas. Hard tissue thin and insulating material.
- \* Tpi = teeth per inch (number of teeth per inch).

Code	Desc.	Dimensioni <i>lung. x alt. x spes. mm</i>	Distrib. teeth <i>per mm</i>	Distrib. teeth <i>per inch</i>
417RC12265	765	77,0x7,9x1,0	0,7	36 Tpi*

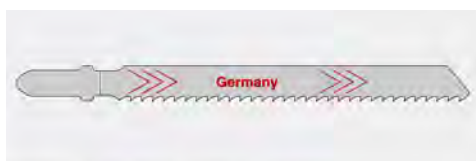

Comparazione lame	
BOSCH	T 127 D
MPS	3118
AEG	274-315
METABO	23 639
WILPU	K 14

- Saw Blade standard smooth.
- For use: mild steel from 3 to 6 mm, non-ferrous metals, aluminum and aluminum alloys from 3 to 15 mm. Plastics and plastics armed. Reinforced concrete, asbestos and harsh substances.
- \* Tpi = teeth per inch (number of teeth per inch).

Code	Desc.	Dimensioni <i>lung. x alt. x spes. mm</i>	Distrib. teeth <i>per mm</i>	Distrib. teeth <i>per inch</i>
417RC12270	770	100,0x7,9x1,0	3,0	8 Tpi*

4

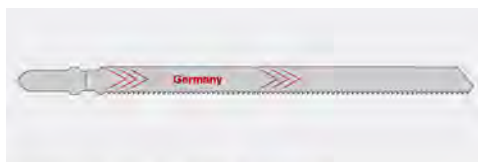

- HSS steel blade.
- Saw Blade standard extra long and wavy.
- For use with: profiles, mild steel and aluminum from 2 to 10 mm, composites and sandwich material up to 70 mm. Insulating material.
- \* Tpi = teeth per inch (number of teeth per inch).



Comparazione lame	
BOSCH	T 318 B
MPS	3115
AEG	274-653
METABO	-
WILPU	MG 32 bi

Code	Desc.	Dimensioni <i>lung. x alt. x spes. mm</i>	Distrib. teeth <i>per mm</i>	Distrib. teeth <i>per inch</i>
417RC12275	775	132,0x7,9x1,3	2,0	13 Tpi*



- HSS steel blade.
- Saw Blade standard extra long and wavy.
- For use with: profiles, steel, mild steel and aluminum from 1.5 to 4 mm, composites and sandwich material up to 70 mm. Insulating material.
- \* Tpi = teeth per inch (number of teeth per inch).



Comparazione lame	
BOSCH	T 318 A
MPS	3115
AEG	274-654
METABO	23 629
WILPU	MG 31 bi

Code	Desc.	Dimensioni <i>lung. x alt. x spes. mm</i>	Distrib. teeth <i>per mm</i>	Distrib. teeth <i>per inch</i>
417RC12280	780	132,0x9,5x1,0	1,2	21 Tpi*



- HSS bi-metal blade.
- Saw blade rolling.
- For use: mild steel and non-ferrous metals from 3 to 10 mm thick and stainless steel sheets. Wood with nails. Plexiglas.
- \* Tpi = teeth per inch (number of teeth per inch).



Comparazione lame	
BOSCH	T 118 BF
MPS	3113 F
AEG	340-012
METABO	23 973
WILPU	MG 12 bi

Code	Desc.	Dimensioni <i>lung. x alt. x spes. mm</i>	Distrib. teeth <i>per mm</i>	Distrib. teeth <i>per inch</i>
417RC12285	785	77,0x7,9x1,0	2,0	13 Tpi*



- HSS bi-metal blade.
- Saw blade rolling.
- For use: mild steel, non-ferrous metals, aluminum and aluminum alloys from 1.5 to 4 mm, stainless steel sheet.
- \* Tpi = teeth per inch (number of teeth per inch).



Comparazione lame	
BOSCH	T 118 AF
MPS	3111 F
AEG	340-011
METABO	23 971
WILPU	MG 11 bi

Code	Desc.	Dimensioni <i>lung. x alt. x spes. mm</i>	Distrib. teeth <i>per mm</i>	Distrib. teeth <i>per inch</i>
417RC12290	790	77,0x7,9x1,0	1,2	21 Tpi*

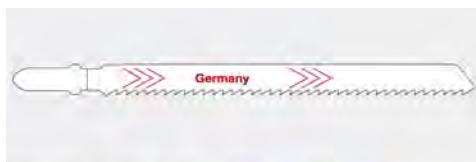

- HSS bi-metal blade.
- Saw blade rolling.
- For use with: profiles and tubes up to 60mm with a wall thickness of from 3 to 10 mm, non-ferrous materials and stainless steel. Wood with nails. Plexiglas and plastic armies.
- \* Tpi = teeth per inch (number of teeth per inch).



Comparazione lame	
BOSCH	T 318 BF
MPS	-
AEG	274-653
METABO	-
WILPU	K 14 bi

Code	Desc.	Dimensioni lungh. x alt. x spes. mm	Distrib. teeth per mm	Distrib. teeth per inch
417RC12295	795	132,0x7,9x1,0	2,0	13 Tpi*



- HSS bi-metal blade.
- Saw blade rolling.
- For use with: profiles and tubes up to 60 mm with a wall thickness of from 1.4 to 4 mm, stainless steel.
- \* Tpi = teeth per inch (number of teeth per inch).



Comparazione lame	
BOSCH	T 318 AF
MPS	-
AEG	274-654
METABO	-
WILPU	MG 31 bi

Code	Desc.	Dimensioni lungh. x alt. x spes. mm	Distrib. teeth per mm	Distrib. teeth per inch
417RC12300	800	132,0x7,9x1,0	1,2	21 Tpi*

## Blades for wood and materials



- HSS bi-metal Blade.
- Blade smoothed.
- Use for: hard and soft wood up to 60mm, rough cut, high cutting performance, ideal for wood with nails.
- \* Tpi = teeth per inch (number of teeth per inch).



Comparazione lame	
BOSCH	T 144 DF
MPS	-
AEG	-
METABO	-
WILPU	HGS 14 bi

Code	Desc.	Dimensioni lungh. x alt. x spes. mm	Distrib. teeth per mm	Distrib. teeth per inch
417RC12320	820	100,0x7,9x1,3	4,0	6 Tpi*

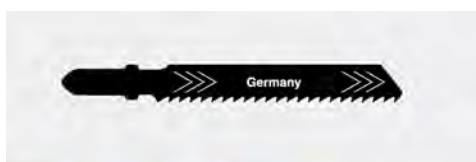

- HCS blade (tool steel).
- Saw blade standard, wavy.
- For use with: panels of plywood and wood fiber to a thickness of the material of 30 mm. Insulating substances and Plexiglas up to 6 mm. Hard tissue to a thickness of 4 mm. Cardboard and linoleum up to a thickness of 6 mm.
- \* Tpi = teeth per inch (number of teeth per inch).



Comparazione lame	
BOSCH	T 119 B
MPS	3108
AEG	274-353
METABO	23 631
WILPU	HW 12

Code	Desc.	Dimensioni lungh. x alt. x spes. mm	Distrib. teeth per mm	Distrib. teeth per inch
417RC12325	825	77,0x7,9x1,0	2,0	13 Tpi*



4

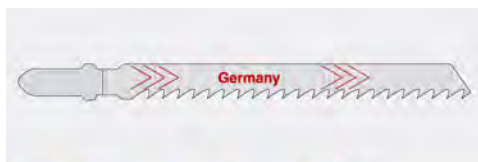

Comparazione lame	
BOSCH	T 101 D
MPS	3105
AEG	274-351
METABO	23 635
WILPU	HGS 24

- HCS blade (tool steel).
- Thin blade, suitable for cutting a curve. Fast cutting and rough. Blade conical teeth filed down.
- For use with: hardwood, softwood, plywood panels and wood fiber to a thickness of 50 mm, clean cut, suitable for engraving. Various soft plastics up to 30 mm, clean cut.
- \* Tpi = teeth per inch (number of teeth per inch).

Code	Desc.	Dimensioni <i>lung. x alt. x spes. mm</i>	Distrib. teeth <i>per mm</i>	Distrib. teeth <i>per inch</i>
417RC12330	830	100,0x7,9x1,45	4,0	6 Tpi*



Comparazione lame	
BOSCH	T 101 DP
MPS	3103
AEG	274-351
METABO	23 655
WILPU	HC 14 D

- HCS blade (tool steel).
- Cut quickly and cleanly. blade conical teeth filed down.
- For use with: hardwood, softwood, plywood panels and wood fiber to a thickness of 60 mm, parallel cuts, clean cut. Various soft plastics up to 25 mm, clean cut.
- \* Tpi = teeth per inch (number of teeth per inch).

Code	Desc.	Dimensioni <i>lung. x alt. x spes. mm</i>	Distrib. teeth <i>per mm</i>	Distrib. teeth <i>per inch</i>
417RC12335	835	100,0x7,9x1,7	4,0	6 Tpi*

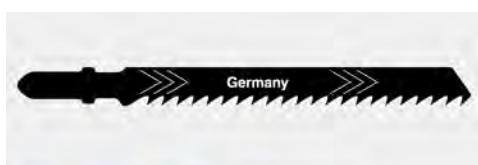

Comparazione lame	
BOSCH	T 144 D
MPS	3104
AEG	213-116
METABO	23 633
WILPU	HGS 14

- HCS blade (tool steel).
- Blade smoothed. Fast cutting and rough.
- Use for: hard and soft wood up to 60 mm, cutting fast and rough. Polystyrene, polyamide and soft plastics up to 50 mm, acrylic up to 30 mm. Hard tissue, insulation material and cardboard.
- \* Tpi = teeth per inch (number of teeth per inch).

Code	Desc.	Dimensioni <i>lung. x alt. x spes. mm</i>	Distrib. teeth <i>per mm</i>	Distrib. teeth <i>per inch</i>
417RC12340	840	100,0x7,5x1,3	4,0	6 Tpi*



Comparazione lame	
BOSCH	T 244 D
MPS	-
AEG	346-078
METABO	23 649
WILPU	-

- HCS blade (tool steel).
- Blade smoothed. Suitable for curved cuts.
- Use for: hard and soft wood up to 60 mm, rough cut, particularly suitable for cutting curves. Polystyrene, polyamide and soft plastics up to 50 mm.
- \* Tpi = teeth per inch (number of teeth per inch).

Code	Desc.	Dimensioni <i>lung. x alt. x spes. mm</i>	Distrib. teeth <i>per mm</i>	Distrib. teeth <i>per inch</i>
417RC12345	845	100,0x6,4x1,3	4,0	6 Tpi*





Comparazione lame	
BOSCH	T 111 C
MPS	-
AEG	254-071
METABO	23 632
WILPU	HG 13

- HCS blade (tool steel).
- Blade smoothed. Rough cut with high cutting performance.
- Use for: hard and soft wood up to 60mm, rough cut, high cutting performance. Polystyrene, polyamide and soft plastics up to 30 mm.
- \* Tpi = teeth per inch (number of teeth per inch).

Code	Desc.	Dimensioni <i>lung. x alt. x spes. mm</i>	Distrib. teeth <i>per mm</i>	Distrib. teeth <i>per inch</i>
417RC12350	850	100,0x7,9x1,3	3,0	8 Tpi*

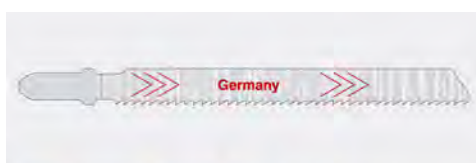

Comparazione lame	
BOSCH	T 101 B
MPS	3101
AEG	254-061
METABO	23 634
WILPU	HC 12

- HCS blade (tool steel).
- Cut quickly and cleanly. Blade conical teeth filed down.
- For use with: hard and soft wood, plywood panels and wood fiber to a thickness of the material of 50 mm, suitable for engraving. Various soft plastics up to 20 mm.
- \* Tpi = teeth per inch (number of teeth per inch).

Code	Desc.	Dimensioni <i>lung. x alt. x spes. mm</i>	Distrib. teeth <i>per mm</i>	Distrib. teeth <i>per inch</i>
417RC12355	855	100,0x7,9x1,45	2,5	10 Tpi*

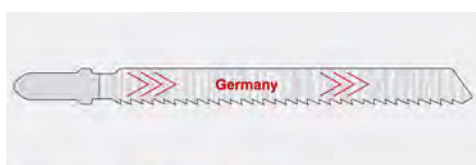

Comparazione lame	
BOSCH	T 101 BR
MPS	3102
AEG	346-079
METABO	23 650
WILPU	HC 12 R

- HCS blade (tool steel).
- Clean cut. Blade conical teeth filed down. cutting direction reverse
- For use with: hard and soft wood, plywood panels and wood fiber to a thickness of the material of 60 mm, Resopal panels and coated panels. Soft plastics.
- \* Tpi = teeth per inch (number of teeth per inch).

Code	Desc.	Dimensioni <i>lung. x alt. x spes. mm</i>	Distrib. teeth <i>per mm</i>	Distrib. teeth <i>per inch</i>
417RC12360	860	100,0x7,9x1,45	2,5	10 Tpi*



Comparazione lame	
BOSCH	T 301 D
MPS	3101 L
AEG	-
METABO	23 654
WILPU	-

- HCS blade (tool steel).
- Blade conical teeth filed down.
- For use with: hard and soft wood, plywood panels and wood fiber to a thickness of the material of 70 mm, clean cut, suitable for engraving. Various soft plastics up to 40 mm, clean cut.
- \* Tpi = teeth per inch (number of teeth per inch).

Code	Desc.	Dimensioni <i>lung. x alt. x spes. mm</i>	Distrib. teeth <i>per mm</i>	Distrib. teeth <i>per inch</i>
417RC12365	865	117,0x7,9x1,45	4,0	6 Tpi*



- HCS blade (tool steel).
- Cut very quickly and cleanly. Blade conical teeth filed down.
- For use with: hard and soft wood, plywood panels and wood fiber to a thickness of 70 mm, cut clean and fast, suitable for engraving. Various soft plastics up to 40 mm, clean cut.
- \* Tpi = teeth per inch (number of teeth per inch).

Comparazione lame	
BOSCH	T 301 DL
MPS	3104 L
AEG	-
METABO	-
WILPU	HGS 34

Code	Desc.	Dimensioni lung. x alt. x spes. mm	Distrib. teeth per mm	Distrib. teeth per inch
417RC12370	870	132,0x9,5x1,45	4,0	6 Tpi*

## Universal saber blades for saws

- Saber saw blades, with universal.
- For each type of material, thickness and all cuttings.
- Available in various lengths for different thicknesses of materials.

## Blades for metal



- Blade HM (hard metal).
- Sharp teeth.
- Use for: stainless steel sheets with a material thickness of 2.0 to 4.0 mm, stainless steel profiles of  $\varnothing$  2.0 to 50.0 mm, the concrete of 2.0 -15.0 mm.
- \* Tpi = teeth per inch (number of teeth per inch).

Comparazione lame	
BOSCH	S 518 EHM
MPS	-
AEG	-
METABO	-
WILPU	-

Code	Desc.	Dimensioni lung. x alt. x spes. mm	Distrib. teeth per mm	Distrib. teeth per inch
417RC12400	900	115,0x18,0x1,25	1,4	18 Tpi*



- HSS bi-metal blade.
- Teeth smoothed and milled.
- Use for: sturdy sheet with a material thickness of 3.0 to 8.0 mm, pipes and profiles of massive  $\varnothing$  10.0 to 100.0 mm, fast cutting.
- \* Tpi = teeth per inch (number of teeth per inch).

Comparazione lame	
BOSCH	S 922 BF
MPS	4411
AEG	323-810
METABO	31130
WILPU	3013-150

Code	Desc.	Dimensioni lung. x alt. x spes. mm	Distrib. teeth per mm	Distrib. teeth per inch
417RC12405	905	150,0x18,0x0,9	1,8	14 Tpi*



- HSS bi-metal Blade.
- Teeth smoothed and milled.
- Use for: plate thickness of the material from thin to thick of 1.0 to 8.0 mm, profiles thin to robust  $\varnothing$  5.0 to 100.0 mm.
- \* Tpi = teeth per inch (number of teeth per inch).



Comparazione lame	
BOSCH	S 123 XF
MPS	-
AEG	-
METABO	-
WILPU	-

Code	Desc.	Dimensioni lungh. x alt. x spes. mm	Distrib. teeth per mm	Distrib. teeth per inch
417RC12410	910	150,0x18,0x0,9	1,8	14 Tpi*



- HSS bi-metal Blade.
- Teeth smoothed and milled.
- Use for: thin sheets with a material thickness of 1.5 to 4.0 mm, pipes and profiles  $\varnothing$  5.0 to 100.0 mm.
- \* Tpi = teeth per inch (number of teeth per inch).



Comparazione lame	
BOSCH	S 922 EF
MPS	4401
AEG	323-809
METABO	31 132
WILPU	3014-150

Code	Desc.	Dimensioni lungh. x alt. x spes. mm	Distrib. teeth per mm	Distrib. teeth per inch
417RC12415	915	150,0x18,0x0,9	1,4	18 Tpi*



- HSS bi-metal Blade.
- Teeth corrugated perforated.
- Used for: thin sheets with a material thickness of 0.7 to 3.0 mm, pipes and profiles  $\varnothing$  5.0 to 10.0 mm, easy and precise cut.
- \* Tpi = teeth per inch (number of teeth per inch).



Comparazione lame	
BOSCH	S 922 AF
MPS	4405
AEG	318-128
METABO	31 129
WILPU	3015-150

Code	Desc.	Dimensioni lungh. x alt. x spes. mm	Distrib. teeth per mm	Distrib. teeth per inch
417RC12420	920	150,0x18,0x0,9	1,0	24 Tpi*



- HSS bi-metal Blade.
- Teeth smoothed and milled.
- Use for: plate thickness of the material medium to thick of 2.0 to 12.0 mm, pipes and profiles of massive  $\varnothing$  10.0 to 150.0 mm, clearcutting fast and flexible.
- \* Tpi = teeth per inch (number of teeth per inch).



Comparazione lame	
BOSCH	S 1025 VF
MPS	-
AEG	-
METABO	-
WILPU	-

Code	Desc.	Dimensioni lungh. x alt. x spes. mm	Distrib. teeth per mm	Distrib. teeth per inch
417RC12425	925	200,0x18,0x1,25	1,8-2,4	10-14 Tpi*

4



Comparazione lame	
BOSCH	S 1122 BF
MPS	4415
AEG	-
METABO	31135/31485
WILPU	3013-200

- HSS bi-metal Blade.
- Teeth smoothed and milled.
- Use for: sturdy sheet with a material thickness of 3.0 - 8.0mm, tubes and profiles of massive  $\varnothing$  10.0 to 175.0 mm, clearcutting fast and flexible.
- \* Tpi = teeth per inch (number of teeth per inch).

Code	Desc.	Dimensioni <i>lung. x alt. x spes. mm</i>	Distrib. teeth <i>per mm</i>	Distrib. teeth <i>per inch</i>
417RC12430	930	225,0x18,0x0,9	1,8	14 Tpi*



Comparazione lame	
BOSCH	S 1122 EF
MPS	4402
AEG	323-812
METABO	31133/31483
WILPU	3014-200

- HSS bi-metal Blade.
- Teeth smoothed and milled.
- Use for: thin sheets with a material thickness of 1.5 to 4.0 mm, pipes and profiles  $\varnothing$  5.0 to 175.00 mm, clearcutting flexible.
- \* Tpi = teeth per inch (number of teeth per inch).

Code	Desc.	Dimensioni <i>lung. x alt. x spes. mm</i>	Distrib. teeth <i>per mm</i>	Distrib. teeth <i>per inch</i>
417RC12435	935	225,0x18,0x0,9	1,4	18 Tpi*

## Blades for metal and wood



Comparazione lame	
BOSCH	S 610 DF
MPS	-
AEG	-
METABO	-
WILPU	-

- HSS bi-metal blade.
- Teeth Smoothed and milled.
- Used for: wood with nails, metal, chipboard with a material thickness of 10.0 to 100.0 mm, plastic profiles of  $\varnothing$  5.0 to 100 mm, massive plastic / concrete of 8.0 to 50.0 mm, window frames of wood and metal. Especially suitable to cut underwater.
- \* Tpi = teeth per inch (number of teeth per inch).

Code	Desc.	Dimensioni <i>lung. x alt. x spes. mm</i>	Distrib. teeth <i>per mm</i>	Distrib. teeth <i>per inch</i>
417RC12455	955	150,0x21,0x1,6	4,2	6 Tpi*



Comparazione lame	
BOSCH	S 920 CF
MPS	-
AEG	-
METABO	-
WILPU	-

- HSS bi-metal Blade.
- Teeth smoothed and milled.
- Use for: plates of 4.0 to 10.0 mm, pipes and profiles of massive  $\varnothing$  20.0 to 100.0 mm. Ideal for devices for cutting and rescue work and demolition. Powerful cutting and coarse.
- \* Tpi = teeth per inch (number of teeth per inch).

Code	Desc.	Dimensioni <i>lung. x alt. x spes. mm</i>	Distrib. teeth <i>per mm</i>	Distrib. teeth <i>per inch</i>
417RC12460	960	150,0x21,0x1,6	2,9	8-10 Tpi*



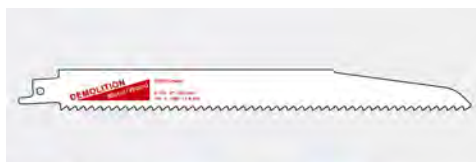

Comparazione lame	
BOSCH	S 1110 DF
MPS	-
AEG	-
METABO	-
WILPU	-

- HSS bi-metal Blade.
- Teeth smoothed and milled.
- Used for: wood with nails, metal, chipboard with a material thickness of 10.0 to 175.0 mm, massive plastic / concrete of 8.0 to 50.0 mm, holes on the walls of wood and metal up to 150 , 0 mm. For relief work and demolition.
- \* Tpi = teeth per inch (number of teeth per inch).

Code	Desc.	Dimensioni <i>lung. x alt. x spes. mm</i>	Distrib. teeth <i>per mm</i>	Distrib. teeth <i>per inch</i>
417RC12465	965	225,0x21,0x1,6	4,2	6 Tpi*



Comparazione lame	
BOSCH	S 1120 CF
MPS	-
AEG	-
METABO	-
WILPU	-

- HSS bi-metal Blade.
- Teeth smoothed and milled.
- Use for: plates of 4.0 to 10.0 mm, pipes and profiles of massive  $\varnothing$  20.0 to 175.0 mm. Ideal for devices for cutting and rescue work and demolition. Powerful cutting and coarse.
- \* Tpi = teeth per inch (number of teeth per inch).

Code	Desc.	Dimensioni <i>lung. x alt. x spes. mm</i>	Distrib. teeth <i>per mm</i>	Distrib. teeth <i>per inch</i>
417RC12470	970	225,0x21,0x1,6	2,9	8-10 Tpi*



Comparazione lame	
BOSCH	S 611 DF
MPS	4016
AEG	318-127
METABO	31123/31473
WILPU	-

- HSS bi-metal Blade.
- Teeth smoothed and milled.
- Used for: wood with nails, metal, chipboard with a material thickness of 10.0 to 100.0 mm, plastic profiles of  $\varnothing$  5.0 to 100.0 mm, massive plastic / concrete of 8.0 to 50 , 0 mm, window frames of wood and metal. Especially suitable to cut underwater.
- \* Tpi = teeth per inch (number of teeth per inch).

Code	Desc.	Dimensioni <i>lung. x alt. x spes. mm</i>	Distrib. teeth <i>per mm</i>	Distrib. teeth <i>per inch</i>
417RC12475	975	150,0x18,0x1,25	4,2	6 Tpi*



Comparazione lame	
BOSCH	S 922 HF
MPS	4430
AEG	-
METABO	31131
WILPU	-

- HSS bi-metal Blade.
- Teeth smoothed and milled.
- For use with: wood with nails, metal with a material thickness of 5.0 to 100.0 mm, metal sheets, pipes, aluminum profiles of 3.0 to 12.0 mm and the pallet.
- \* Tpi = teeth per inch (number of teeth per inch).

Code	Desc.	Dimensioni <i>lung. x alt. x spes. mm</i>	Distrib. teeth <i>per mm</i>	Distrib. teeth <i>per inch</i>
417RC12480	980	150,0x18,0x0,9	2,5	10 Tpi*



4



Comparazione lame	
BOSCH	S 3456 XF
MPS	-
AEG	-
METABO	-
WILPU	-

- HSS bi-metal Blade.
- Teeth smoothed and milled.
- Used for: wood with nails and metal, chipboard with a material thickness of 5.0 to 150.0 mm, metal sheets, aluminum profiles of 3.0 -18.0 mm, plastic / concrete and profiles ø 5.0 to 150.0 mm.
- \* Tpi = teeth per inch (number of teeth per inch).

Code	Desc.	Dimensioni <i>lung. x alt. x spes. mm</i>	Distrib. teeth <i>per mm</i>	Distrib. teeth <i>per inch</i>
417RC12485	985	200,0x18,0x1,25	2,1-4,3	6-12 Tpi*



Comparazione lame	
BOSCH	S 1022 HF
MPS	4431
AEG	-
METABO	-
WILPU	-

- HSS bi-metal blade.
- Teeth smoothed and milled.
- For use with: wood with nails and metal with a material thickness of 5.0 to 150.0 mm, metal sheets, pipes, aluminum profiles of 3.0 to 12.0 mm and the pallet.
- \* Tpi = teeth per inch (number of teeth per inch).

Code	Desc.	Dimensioni <i>lung. x alt. x spes. mm</i>	Distrib. teeth <i>per mm</i>	Distrib. teeth <i>per inch</i>
417RC12490	990	200,0x18,0x0,9	2,5	10 Tpi*



Comparazione lame	
BOSCH	S 1111 DF
MPS	-
AEG	318-125
METABO	-
WILPU	-

- HSS bi-metal Blade.
- Teeth smoothed and milled.
- Used for: wood with nails and metal, chipboard with a material thickness of 10.0 to 175.0 mm, plastic profiles of ø 5.0 to 175.0 mm, massive plastic / concrete of 8.0 to 50 , 0 mm.
- \* Tpi = teeth per inch (number of teeth per inch).

Code	Desc.	Dimensioni <i>lung. x alt. x spes. mm</i>	Distrib. teeth <i>per mm</i>	Distrib. teeth <i>per inch</i>
417RC12495	995	225,0x18,0x1,25	4,2	6 Tpi*

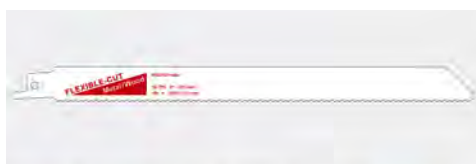

Comparazione lame	
BOSCH	S 1122 HF
MPS	-
AEG	-
METABO	-
WILPU	-

- HSS bi-metal Blade.
- Teeth smoothed and milled.
- For use with: wood with nails and metal with a material thickness of 5.0 to 175.0 mm, metal sheets, pipes, aluminum profiles of 3.0 to 12.0 mm and the pallet. Clearcutting flexible.
- \* Tpi = teeth per inch (number of teeth per inch).

Code	Desc.	Dimensioni <i>lung. x alt. x spes. mm</i>	Distrib. teeth <i>per mm</i>	Distrib. teeth <i>per inch</i>
417RC12500	1000	225,0x18,0x1,25	2,5	10 Tpi*



- HSS bi-metal Blade.
- Teeth smoothed and milled.
- For use with: wood with nails and metal with a material thickness of 5.0 to 175.0 mm, metal sheets, aluminum profiles of 3.0 to 10.0 mm and plastic profiles of  $\varnothing$  3.0 to 175, 0 mm.
- \* Tpi = teeth per inch (number of teeth per inch).



Comparazione lame	
BOSCH	S 1125 VF
MPS	-
AEG	323-813
METABO	-
WILPU	-

Code	Desc.	Dimensioni <i>lung. x alt. x spes. mm</i>	Distrib. teeth <i>per mm</i>	Distrib. teeth <i>per inch</i>
417RC12505	1005	225,0x18,0x1,25	2,5	10-14 Tpi*



- HSS bi-metal Blade.
- Teeth smoothed and milled.
- For use with: wood with nails and metal with a material thickness of 5.0 to 175.0 mm, metal sheets, aluminum profiles of 3.0 to 10.0 mm and plastic profiles of  $\varnothing$  3.0 to 175, 0 mm. Clearcutting flexible.
- \* Tpi = teeth per inch (number of teeth per inch).



Comparazione lame	
BOSCH	S 1125 VF
MPS	-
AEG	323-813
METABO	-
WILPU	-

Code	Desc.	Dimensioni <i>lung. x alt. x spes. mm</i>	Distrib. teeth <i>per mm</i>	Distrib. teeth <i>per inch</i>
417RC12510	1010	225,0x18,0x0,9	1,8-2,4	10-14 Tpi*



- HSS bi-metal Blade.
- Teeth smoothed and milled.
- Used for: wood with nails, metal and particle board with a material thickness of 10.0 to 250.0 mm, porous concrete of 10.0 to 250.0 mm, plastic / concrete and profiles from 5.0 to 60, 0 mm.
- \* Tpi = teeth per inch (number of teeth per inch).



Comparazione lame	
BOSCH	S 1411 DF
MPS	-
AEG	-
METABO	-
WILPU	3021-300 bi

Code	Desc.	Dimensioni <i>lung. x alt. x spes. mm</i>	Distrib. teeth <i>per mm</i>	Distrib. teeth <i>per inch</i>
417RC12515	1015	300,0x18,0x1,25	4,2	6 Tpi*

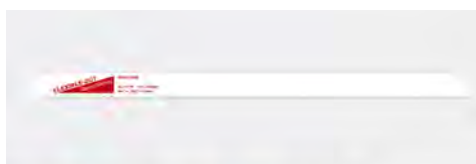

- HSS bi-metal blade.
- Teeth smoothed and milled.
- For use with: wood with nails and metal with a material thickness of 5.0 to 250.0 mm, metal sheets, aluminum profiles of 3.0 to 10.0 mm, and plastic profiles of  $\varnothing$  3.0 to 250, 0 mm. clearcutting flexible.
- \* Tpi = teeth per inch (number of teeth per inch).



Comparazione lame	
BOSCH	S 1222 VF
MPS	4432
AEG	323-813
METABO	31125/31475
WILPU	3018-280

Code	Desc.	Dimensioni <i>lung. x alt. x spes. mm</i>	Distrib. teeth <i>per mm</i>	Distrib. teeth <i>per inch</i>
417RC12520	1020	300,0x18,0x0,9	2,5	10-14 Tpi*

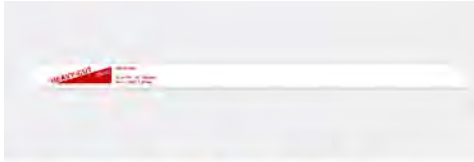

Comparazione lame	
BOSCH	S 1225 VF
MPS	4422
AEG	-
METABO	31124-31474
WILPU	-

- HSS bi-metal Blade.
- Teeth smoothed and milled.
- For use with: wood with nails and metal with a material thickness of 5.0 to 250.0 mm, metal sheets, aluminum profiles of 3.0 to 10.0 mm, and plastic profiles of  $\varnothing$  3.0 to 250, 0 mm.
- \* Tpi = teeth per inch (number of teeth per inch).

Code	Desc.	Dimensioni <i>lungh. x alt. x spes. mm</i>	Distrib. teeth <i>per mm</i>	Distrib. teeth <i>per inch</i>
417RC12525	1025	300,0x18,0x0,9	1,8-2,4	10-14 Tpi*

## Blades for wood



Comparazione lame	
BOSCH	S 617 K
MPS	4021
AEG	-
METABO	-
WILPU	3019-150

- HCS blade (tool steel).
- Teeth Smoothed and milled.
- Used for: wood without nails and gross of 20.0 to 100.0 mm, living wood, branches up to  $\varnothing$  100.0 mm. Especially suitable for curved cuts and underwater.
- \* Tpi = teeth per inch (number of teeth per inch).

Code	Desc.	Dimensioni <i>lungh. x alt. x spes. mm</i>	Distrib. teeth <i>per mm</i>	Distrib. teeth <i>per inch</i>
417RC12530	1030	150,0x18,0x1,25	8,5	3 Tpi*



Comparazione lame	
BOSCH	S 828 D
MPS	4014
AEG	318-131/323-801
METABO	31136
WILPU	3025-150

- HCS blade (tool steel).
- smoothed teeth.
- Use for: especially suitable for plasterboard panels of 8.0 to 100.0 mm. Wood, asbestos and plastics.
- \* Tpi = teeth per inch (number of teeth per inch).

Code	Desc.	Dimensioni <i>lungh. x alt. x spes. mm</i>	Distrib. teeth <i>per mm</i>	Distrib. teeth <i>per inch</i>
417RC12535	1035	150,0x18,0x0,9	4,2	6 Tpi*



Comparazione lame	
BOSCH	S 644 D
MPS	4011
AEG	323-800
METABO	31120/31470
WILPU	3021-150

- HCS blade (tool steel).
- smoothed and sharp teeth.
- Use for: lumber, plywood and plastics of 6.0 to 100.0 mm, wooden walls up to 75.0 mm, chipboard of 6.0 to 60.0 mm. Especially suitable to cut underwater.
- \* Tpi = teeth per inch (number of teeth per inch).

Code	Desc.	Dimensioni <i>lungh. x alt. x spes. mm</i>	Distrib. teeth <i>per mm</i>	Distrib. teeth <i>per inch</i>
417RC12540	1040	150,0x18,0x1,25	4,2	6 Tpi*

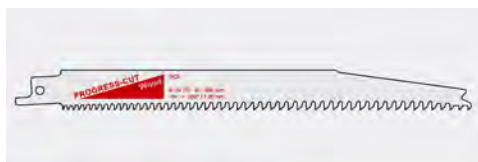

- HCS blade (tool steel).
- Smoothed and sharp teeth.
- Use for: lumber, plywood and plastics of 6.0 to 150.0 mm, wooden walls up to 175.0 mm, chipboard of 6.0 to 60.0 mm.
- \* Tpi = teeth per inch (number of teeth per inch).



Comparazione lame	
BOSCH	S 2345 X
MPS	-
AEG	-
METABO	-
WILPU	-

Code	Desc.	Dimensioni <i>lung. x alt. x spes. mm</i>	Distrib. teeth <i>per mm</i>	Distrib. teeth <i>per inch</i>
417RC12545	1045	200,0x18,0x1,25	2,5-4,3	6-10 Tpi*



- HCS blade (tool steel).
- Teeth Smoothed and milled.
- Use for: coarse wood and no nails from 20.0 to 175.0 mm, firewood  $\varnothing$  20.0 to 175.0 mm.
- \* Tpi = teeth per inch (number of teeth per inch).



Comparazione lame	
BOSCH	S 1111 K
MPS	-
AEG	-
METABO	-
WILPU	-

Code	Desc.	Dimensioni <i>lung. x alt. x spes. mm</i>	Distrib. teeth <i>per mm</i>	Distrib. teeth <i>per inch</i>
417RC12550	1050	225,0x18,0x1,25	8,5	3 Tpi*



- HCS blade (tool steel).
- Smoothed and sharp teeth.
- Use for: coarse wood and no nails from 15.0 to 190.0 mm, living wood, branches up to  $\varnothing$  190.0 mm, firewood  $\varnothing$  15.0 to 190.0 mm.
- \* Tpi = teeth per inch (number of teeth per inch).



Comparazione lame	
BOSCH	S 1531 L
MPS	4052
AEG	323-803
METABO	31139/31488
WILPU	3029-240

Code	Desc.	Dimensioni <i>lung. x alt. x spes. mm</i>	Distrib. teeth <i>per mm</i>	Distrib. teeth <i>per inch</i>
417RC12555	1055	240,0x18,0x1,6	4,0-6,5	5 Tpi*



- HCS blade (tool steel).
- Smoothed and sharp teeth.
- Use for: building timber, wooden walls, chipboard, plywood, plastic.
- \* Tpi = teeth per inch (number of teeth per inch).



Comparazione lame	
BOSCH	S 1344 D
MPS	4015
AEG	323-802
METABO	31122/31472
WILPU	3021-300

Code	Desc.	Dimensioni <i>lung. x alt. x spes. mm</i>	Distrib. teeth <i>per mm</i>	Distrib. teeth <i>per inch</i>
417RC12560	1060	300,0x18,0x1,25	4,2	6 Tpi*

## Rotary burrs in hard metal

- Used for welding points and removal of metal chips.
- to long-term.
- With cross-cut to treated steel, stainless steel and all metal materials in general.
- Reduced vibration for the type of cut.
- Good surface finish.
- To be used with pneumatic grinders or drills.
- Speed 'recommended 450 to 600 m / min.

### Cylindrical-cut front

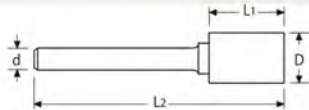

Code	Desc. D x L1	d x L2
4430047059	773 - 6x8	6x50
4430047060	773 - 8x18	6x63
4430047062	773 - 10x20	6x65
4430047064	773 - 12x25	6x70
4430047066	773 - 16x25	6x70

### Conical

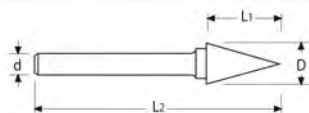

Code	Desc. D x L1	d x L2
4430047068	774 - 6x20	6x50
4430047070	774 - 8x18	6x63
4430047072	774 - 10x20	6x65
4430047074	774 - 12x25	6x70
4430047076	774 - 16x25	6x70

### Flame type

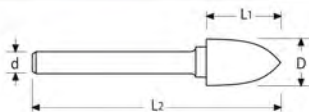

Code	Desc. D x L1	d x L2
4430047078	775 - 6x18	6x50
4430047080	775 - 8x18	6x63
4430047082	775 - 10x20	6x65
4430047084	775 - 12x25	6x70
4430047086	775 - 16x25	6x70

### Spherical

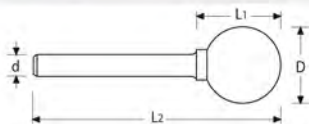

Code	Desc. D x L1	d x L2
4430047088	776 - 6x5	6x50
4430047090	776 - 8x7	6x52
4430047092	776 - 10x9	6x54
4430047094	776 - 12x10	6x55
4430047096	776 - 16x14	6x59

### Cylindrical with spherical head

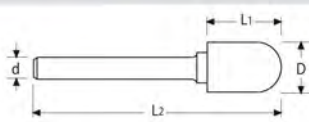

Code	Desc. D x L1	d x L2
4430047098	777 - 6x18	6x50
4430047100	777 - 8x18	6x63
4430047102	777 - 10x20	6x65
4430047104	777 - 12x25	6x70
4430047106	777 - 16x25	6x70



## Drop

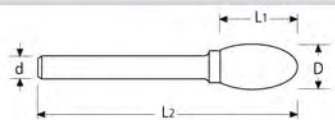

Code	Desc. D x L1	d x L2
4430047108	778 - 6x10	6x50
4430047110	778 - 8x13	6x58
4430047112	778 - 10x16	6x61
4430047114	778 - 12x20	6x65
4430047116	778 - 16x25	6x70



## Drills with cylindrical HSS-G

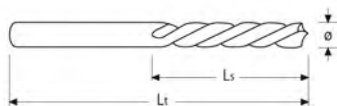

4

- In HSS-G
- DIN 338
- Hand spiral, straight shank, short series
- **Running entirely rectified**
- For drilling all metals: iron, steel, cast iron, etc.
- \* **N.B. : ø 13.5 on reduced diameter shank 13.**

Code	Desc. Ø	Ls mm	Lt mm
3250000100	1	12	34
3250000200	1.5	18	40
3250000300	2	24	49
3250000400	2.5	30	57
3250000500	3	33	61
3250000600	3.5	39	70
3250000700	4	43	75
3250000800	4.5	47	80
3250000900	5	52	86
3250001000	5.5	57	93
3250001100	6	57	93
3250001200	6.5	63	101
3250001300	7	69	109
3250001400	7.5	69	109
3250001500	8	75	117
3250001600	8.5	75	117
3250001700	9	81	125
3250001800	9.5	81	125
3250001900	10	87	133
3250002000	10.5	87	133
3250002100	11	94	142
3250002200	11.5	94	142
3250002300	12	101	151
3250002400	12.5	101	151
3250002500	13	101	151
3250002600	13.5*	108	160
3250002700	14*	108	160
3250002800	14.5*	114	169
3250002900	15*	114	169
3250003000	15.5*	120	178
3250003100	16*	120	178
3250003200	16.5*	125	186
3250003300	17*	125	186
3250003400	17.5*	130	194
3250003500	18*	130	194
3250003600	18.5*	135	202
3250003700	19*	135	202
3250003800	19.5*	140	210
3250003900	20*	140	210

## Assortments tips ground in metal box



- For drilling without damaging the tip

Code	Desc.
3251000200	1-10
3252000200	1-13

TABELLA DI FORATURA, ROTAZIONE PUNTA/VELOCITÀ MANDRINO

Ø mm	1	1,5	2	2,5	3	3,5	4	4,5	5	5,5	6	7	8	9	10	11	12	13	14
RPM	3500	3500	2500	2000	1800	1500	1500	1300	1200	1150	1100	900	800	700	620	550	500	450	380

## Punte elicoidali cilindriche di precisione in HSS-G - misure decimali



- In acciaio superrapido HSS-G.
- DIN 338.
- Elica destra, codolo cilindrico, serie corta.
- Esecuzione interamente rettificata.
- Per forare tutti i metalli che richiedono lavori di precisione.
- N.B.: da  $\varnothing$  13,5 in poi codolo ridotto  $\varnothing$  13.

Code
32700*****

\*\*\*\*\* MISURE: VEDI LISTINO

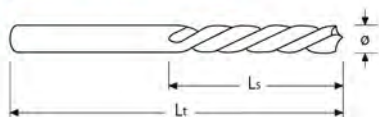

## Assortments drills cylindrical metal container



- Conveniently metal box
- DIN 338
- Running entirely rectified
- For drilling all kinds of metal: iron, steel, cast iron, etc.

Code	Desc.	Content
3270100100	116	51 TIPS $\varnothing$ from 1 to 6 progression $\varnothing$ 0.1 mm

## Assortments drills cylindrical metal container



- Conveniently metal box
- DIN 338
- Running entirely rectified
- For drilling all kinds of metal: iron, steel, cast iron, etc.

Code	Desc.	Content
3270100200	610	41 TIPS from $\varnothing$ 6 to $\varnothing$ 10 mm 0.1 mm progression



## Assortments drills with cylindrical shanks



- Conveniently metal box
- DIN 338
- Hand spiral, straight shank, short series
- Running entirely rolled
- For drilling all kinds of metal: iron, steel, cast iron, etc.

4

Code	Desc.	Content	Type
3251000100	110	∅ 1 TO 10 TO 0.5mm	Ass. 19 drills cylinders.
3990001000	2600	METAL BOX EMPTY	Ass. 19 punte elicoidali cilind.
3252000100	113	∅ 1 TO 13 TO 0.5mm	Ass. 25 drills cylinders.
3990001100	2700	METAL BOX EMPTY	Ass. 25 drills cylinders.
3252500100	150	DAL ∅ 1 AL 5 10 pz. per tipo DAL ∅ 5,5 AL 10 5 pz. per tipo	Ass. 150 punte elicoidali cilind.
3990000900	2500	METAL BOX EMPTY	Ch. 150 drills cylinders.

## HSS drills with cylindrical-G series extra short



Code	Desc. ∅	Ls mm	Lt mm
3280000050	2.5	14	43
3280000100	3	16	46
3280000200	3.5	20	52
3280000300	4	22	55
3280000500	5	26	62
3280000700	6	28	66
3280000800	6.5	31	70
3280001100	8	37	79

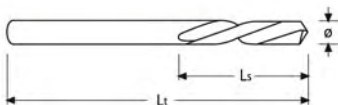

- In HSS-G
- DIN 1897
- Right helix
- Running entirely rectified
- For drilling all metals: iron, steel, etc. chisa
- Punching sheet metal and thin materials

## Tips cylindrical HSS-G extra court doubles



Code	Desc. Ø	Ls mm	Lt mm
3320000300	3	10	46
3320000400	3.5	12	52
3320000500	4	12	55
3320000600	4.5	12	58
3320000700	5	12	62
3320000900	6	16	66

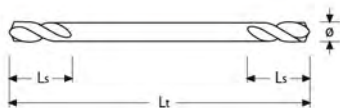

- In HSS-G.
- DIN 1897.
- Cylindrical shaft helical versus right.
- Punching sheet metal and thin materials.
- Suitable for carrying out the holes for the rivets tearing.

## Twist drills super court for tinsmiths HSS-G



- Drills HSS HSS fully rectified.
- Special tips for tinsmiths, carpenters, coperturisti, locksmiths, fitters.
- Drilling sweet and precise thanks to the sharpening "split point" self-centering, of sheet metal and steel pipes, copper and plastic.
- **APPLICATIONS:** These tips are widely used in the field of plumbing to make the pre-hole for the insertion of fixing rivets. It is very short avoid contact with the wall or non-metallic material during the laying of channels of gutters, downspouts and flashings converse.

Code	Desc.	Ø mm	Leng. Lt mm	Leng. Ls mm
3280003100	3,25/SC	3,25	40	19
3280003200	3,50/SC	3,5	40	19
3280003500	4,00/SC	4	40	20
3280003600	4,25/SC	4,25	40	20

## Twist drills Supercorte for tinsmiths HSS-CO



- HSS coated cobalt and completely rectified.
- Special tips for tinsmiths, carpenters, coperturisti, locksmiths, fitters.
- Drilling sweet and precise thanks to the sharpening "split point" self-centering.
- Special, thanks to the covering to cobalt, for drilling sheet metal and stainless steel pipes sheet metal coverings (steel, iron, copper).
- **APPLICATIONS:** These tips are widely used in the field of plumbing to make the pre-hole for the insertion of fixing rivets. It is very short avoid contact with the wall or non-metallic material during the laying of channels

Code	Desc.	Ø mm	Tip length mm	Screw length mm
3230004000	3,5/SC	3,5	40	19
3230004100	4,0/SC	4	40	20



## HSS drills with cylindrical G-series long

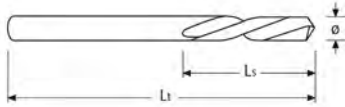
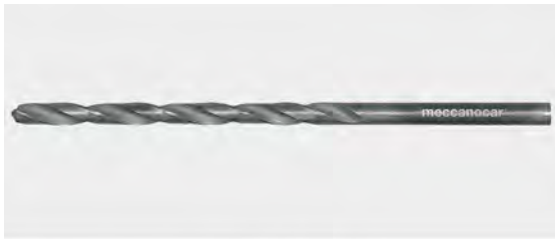

Code	Desc. Ø	Ls mm	Lt mm
3300000100	1	45	70
3300000300	2	56	85
3300000400	2.5	62	95
3300000500	3	66	100
3300000600	3.5	73	112
3300000700	4	78	119
3300000800	4.5	82	126
3300000900	5	87	132
3300001000	5.5	91	139
3300001100	6	91	139
3300001200	6.5	97	148
3300001300	7	102	156
3300001400	7.5	102	156
3300001500	8	109	165
3300001600	8.5	109	165
3300001700	9	115	175
3300001900	10	121	184

- In HSS-G
- DIN 340
- Hand spiral, straight shank, long series
- Running entirely rectified
- For drilling all metals: iron, steel, cast iron, etc.

## HSS twist drills Morse taper shank

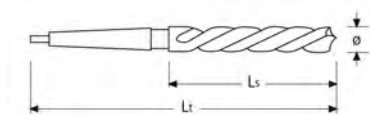

- In HSS
- Right helix
- DIN 345
- Running rolled
- For drilling alloyed and unalloyed cast iron, malleable cast iron, iron, etc.
- For use on stationary machines (drill presses)

Code	Desc. Ø	Ls mm	Lt mm	Cone n.
3290000100	10	87	168	1
3290000200	10.5	87	168	1
3290000300	11	94	175	1
3290000400	11.5	94	175	1
3290000500	12	101	182	1
3290000600	12.5	101	182	1
3290000700	13	101	182	1
3290000900	14	108	189	1
3290001000	14.5	114	212	2
3290001100	15	114	212	2
3290001200	15.5	120	218	2
3290001300	16	120	218	2
3290001400	16.5	125	223	2
3290001500	17	125	223	2
3290001600	17.5	130	228	2
3290001700	18	130	228	2
3290001800	18.5	135	233	2
3290001850	19	135	233	2
3290001870	19.5	140	238	2
3290001900	20	140	238	2
3290002000	20.5	145	243	2
3290002010	21	145	243	2
3290002020	21.5	150	248	2
3290002030	22	150	248	2
3290002050	22.5	155	253	2
3290002100	23	155	253	2
3290002200	23.5	155	276	3
3290002300	24	160	281	3
3290002400	24.5	160	281	3
3290002500	25	160	281	3
3290002600	25.5	165	246	3
3290002700	26	165	286	3
3290002800	26.5	165	286	3
3290002900	27	170	291	3
3290003000	27.5	170	291	3
3290003100	28	170	291	3
3290003200	28.5	175	296	3
3290003300	29	175	296	3
3290003400	29.5	175	296	3
3290003500	30	175	296	3
3290003508	32	185	334	4
3290003512	33	185	334	4
3290003516	34	190	339	4
3290003520	35	190	339	4
3290003540	40	200	349	4
3290003600	50	220	369	4

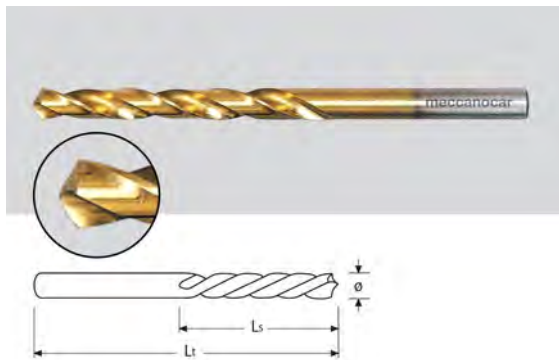

**Drill bits HSS-G titanium**

Code	Desc. Ø	Ls mm	Lt mm
3310000100	1	12	34
3310000200	1.5	18	40
3310000300	2	24	49
3310000400	2.5	30	57
3310000500	3	33	61
3310000600	3.5	39	70
3310000700	4	43	75
3310000800	4.5	47	80
3310000900	5	52	86
3310001000	5.5	57	93
3310001100	6	57	93
3310001200	6.5	63	101
3310001300	7	69	109
3310001400	7.5	69	109
3310001500	8	75	117
3310001600	8.5	75	117
3310001700	9	81	125
3310001800	9.5	81	125
3310001900	10	87	133
3310002000	10.5	87	133
3310002100	11	94	142
3310002200	11.5	94	142
3310002300	12	101	151
3310002400	12.5	101	151
3310002500	13	101	151

- HSS HSS-G
- DIN 338
- Coated nitrocellulose and titanium
- Long-life tip
- Increased speed 'cutting
- For drilling all metals

**Assortment drills titanium**

- Conveniently metal box

Code	Desc.	Content
3311000100	190	ø 1 TO 10 TO 0.5 mm (19 POINTS)
3311000200	250	ø 1 TO 13 TO 0.5 mm (25 POINTS)

## Punte elicoidali al cobalto - 8%



TABELLA DI FORATURA, ROTAZIONE PUNTA/VELOCITÀ MANDRINO PER FORARE SENZA DANNEGGIARE LA PUNTA

	ACCIAIO INOX						ACCIAIO - FERRO									
Ø mm	2	3	4	5	6	8	10	12	2	3	4	5	6	8	10	12
RPM	1600	1060	800	650	550	400	350	290	2400	1600	1200	960	800	600	480	400

SI CONSIGLIA DI LUBRIFICARE CON NS. COD. 411 00 01900 - 2605 CUT OIL TAP

- In acciaio superrapido HSS-G - CO 8%.
- DIN 338.
- Esecuzione interamente rettificata.
- Serie corta.
- Affilatura a diamante DIN 1412/C.
- Per forare: acciaio inox, acciai legati, ghisa,, acciaio dolce, ferro, leghe leggere e tutti i materiali metallici.
- \* Per diametri superiori a 13 il codolo rimane Ø 13.

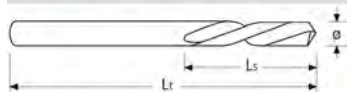
Code	Desc. Ø	Ls mm	Lt mm
3230000100	1	12	34
3230000200	1.5	18	40
3230000300	2	24	49
3230000500	3	33	61
3230000600	3.5	39	70
3230000700	4	43	75
3230000800	4.5	47	80
3230000900	5	52	86
3230001000	5.5	57	93
3230001100	6	57	93
3230001200	6.5	63	101
3230001300	7	69	109
3230001400	7.5	69	109
3230001500	8	75	117
3230001600	8.5	75	117
3230001700	9	81	125
3230001800	9.5	81	125
3230001900	10	87	133
3230002000	10.5	87	133
3230002100	11	94	142
3230002200	11.5	94	142
3230002300	12	101	151
3230002400	12.5	101	151
3230002500	13	108	160
3230002600	13.5 *	108	160
3230002700	14 *	108	160
3230002800	14.5 *	114	169
3230002900	15 *	114	169
3230003000	16 *	120	178
3230003050	16.5 *	125	186

## Assortment tips cobalt



- Conveniently metal box

Code	Desc.	Content
3231000100	112	Ø 1 TO 10 TO 0.5 mm (19 POINTS)
3232000100	114	Ø 1 TO 13 TO 0.5 mm (25 POINTS)

**Punte per legno a 2 taglienti con punta guida**

- For drilling wood and its derivatives.
- For body transformation, installers, etc. infissai.

4

APPLICAZIONI



Code	Desc. / Meas. mm	Screw length mm	Length total mm
3260401603	3	33	61
3260401604	4	43	75
3260401605	5	52	86
3260401606	6	57	93
3260401608	8	75	117
3260401609	9	81	125
3260401611	11	94	142
3260401612	12	94	142
3260401613	13	101	151
3260401614	14	108	160
3260401615	15	114	169
3260401616	16	120	178

**Kit wood bits**



- Kit in handy dispenser plastic.

Code	Description	Content/size
3260401655	Kit 5 punte da 4a10	1pz x mis. 4-5-6-8-10
3260401658	Kit 8 punte da 3a10	1pz x mis. 3-4-5-6-7-8-9-10

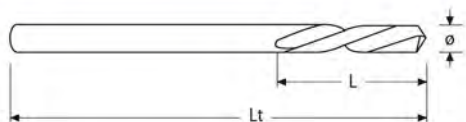

## Universal tips pierces all

**Da usarsi con la sola rotazione!**



- Special tips with very high efficiency, suitable for drilling of hard steel, steel generally, iron, cast iron, all metals, wall, concrete, ceramic, stoneware, floors in general, porcelain, wood and wood products, laminates, etc.
- To poke holes in different materials with only operation
- The points more 'large have reduced shank to allow their use with spindle diameter 13 mm max
- For speed 'rotation follow the applicable table.

Code	Desc. Ø X L tot. mm	L. screw mm
3260400100	4x80	41
3260400200	5x90	44
3260400300	6x100	54
3260400380	6x200	120
3260400400	7x110	59
3260400500	8x120	63
3260400600	10x140	83
3260400700	12x160	99
3260400800	14x160	93
3260400360	6x160	109
3260400580	8x200	120
3260400680	10x200	126

## Assortment tips pierce all



- INSTRUCTIONS FOR USE
- Do not pierce Percussion
- Use adequate protection for the face
- Speed 'rotation recommended:

Velocità di foratura consigliate:

ACCIAIO	2.000 G/min.
GHISA	1.000 G/min.
GRANITO	500 G/min.
CALCESTRUZZO	1.000 G/min.
CEMENTO ARMATO	2.000 G/min.
MARMO	500 G/min.
LEGNO	1.000 G/min.

Code	Desc.	Content
3261100100	410	TIPS Ø 4-5-6-8-10

## Tips for marble

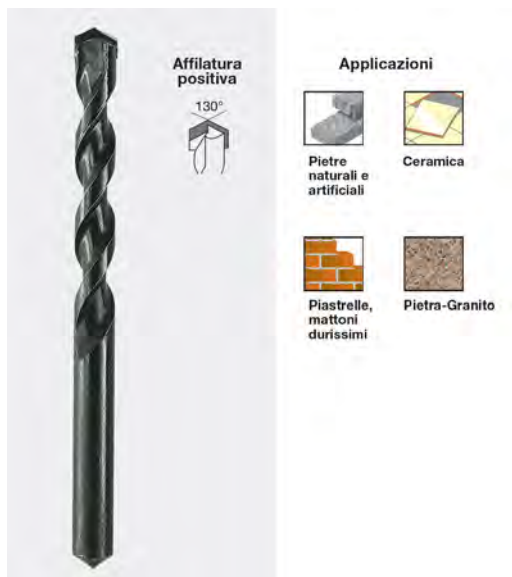

- Drill bits building materials very hard to single spin.
- Hole flawless marble, stone, granite, ceramics and all building materials very hard.
- Carbide with sharp diamond and self-centering.
- Particularly suitable for installers and plumbers.

Code	Desc. / Meas. mm	Ø gambo mm	Screw length mm	Length total mm
3260401503	3	2,8	30	70
3260401504	4	3,8	40	75
3260401505	5	4,5	50	85
3260401506	6	5,5	60	100
3260401507	7	6,5	60	100
3260401508	8	7,5	80	120
3260401510	10	9	80	120
3260401512	12	10	90	150
3260401514	14	10	200	250

## Bit Kits for marble



- Kit in handy dispenser plastic.

Code	Description	Content/size
3260401520	Kit 4 punte da 5a10	1pz x mis. 5-6-8-10

## Bits for glass and ceramics



- Specific hard metal bits for boring glass, ceramic, tiles, stoneware, and marble.
- For use in all working sectors to bore the abovementioned materials, quickly, cleanly and without chips or breakages.
- Used with normal drills at the lowest speed, rotation only and not percussion, cooling with water or turpentine. Specially sharpened to help centre the initial part of the bore, widening the bore constantly during its passage through the surface.

Code	Desc.	Ø hole mm	Length mm	Velocità consigliata Giri/min.
3260402000	3x65	3	65	700-1000
3260402010	4x65	4	65	700-1000
3260402020	5x65	5	65	700-1000
3260402030	6x65	6	65	550-750
3260402040	7x70	7	70	550-750
3260402050	8x70	8	70	550-750
3260402060	9x70	9	70	350-550
3260402070	10x80	10	80	350-550
3260402080	12x80	12	80	250-400
3260402090	13x80	13	80	250-400



## Tips percussion masonry



Particolare doppia scanalatura

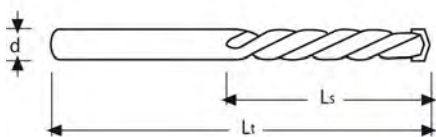

- Carbide tip. Material braised in bronze for high heat resistance and a reduced consumption of the tip.
- Double groove. The finishing dual quenching reduces the incidence of breakages
- Chrome vanadium body. The high carbon content allows more hardening and then the tip and 'more' robust
- To drill: wall concrete, marble, granite and stone

ø mm	5	6 7 8 9 10	11 12 13 14 15 16
RPM	2300	1300	600

Code	Desc.	d mm	Ls mm	Lt mm
3260000030	3x60	3	40	70
3260000060	4x75	4	45	80
3260000100	5x85	5	55	90
3260000200	6x100	6	60	100
3260000250	6x160	6	110	160
3260000260	6,5x160	6,5	110	160
3260000300	7x100	7	70	110
3260000400	8x120	8	80	120
3260000450	8x200	8	150	200
3260000500	9x120	9	90	130
3260000600	10x120	10	100	140
3260001500	10x200	10	150	200
3260000700	11x150	11	110	160
3260000800	12x150	12	110	160
3260000900	13x160	10	100	160
3260001000	14x160	10	110	160
3260001200	16x160	10	110	160

## Centrapunte Meccanocar



- Centrapunte meccanocar con raccoglitore interno della polvere. Costruito con materiale plastico antiurto.
- Possibili utilizzatori: impiantisti termoidraulici ed elettrici, montatori, falegnami, serramenti e carpenteria.
- Permette all'operatore, di creare fori precisi ed in asse sostenendo la punta durante il foro, semplificando la foratura.
- Da utilizzare con tutti i tipi di punte con diametro da 4 fino a 12 mm. Realizzato in robusto materiale plastico antiusura. Dimensioni: 55x50x30h mm.
- Particolarmente indicato per lavori in interni, dove e' necessario ridurre lo sporco. per questo motivo il centrapunte e' dotato di serbatoio interno in grado di raccogliere la polvere depositata.
- Aderisce senza scivolare a tutti i tipi di parete: liscia e ruvida.

Code	Desc.
4430055100	1130

### SEQUENZA D'USO:



Foto 1

SEGNARE LA POSIZIONE DEL FORO DESIDERATA



Foto 2

SELEZIONARE IL DIAMETRO DEL FORO DA PRATICARE



Foto 3

POSIZIONARE IL CENTRAPUNTE SUL SEGNO FATTO PRECEDENTEMENTE



Foto 4

PROCEDERE CON IL LAVORO IN ASSENZA DI POLVERE



Foto 5

SVUOTARE IL SERBATOIO INTERNO

## Assorted tips for masonry



- In case plastic.

Code	Desc.	Content
3260100100	412	7 PZ: Ø 4-5-6-7-8-10-12



Particolare doppia scanalatura

## HSS tip for removing spot welds

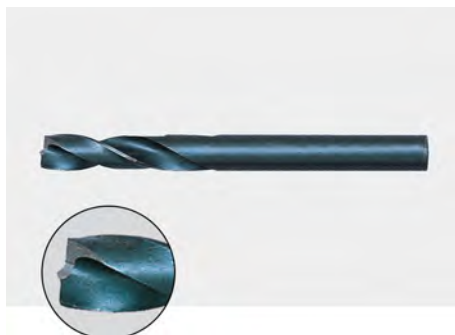

- HSS sharpened special
- Employed with all types of drills
- With centering tip
- It removes with ease 'spot welds and welded sheets typically pierces

Code	Desc.	Lt mm
4770000690	69-6	66
4770000691	69-7	74
4770000692	69-8	79
4770000693	69-10	89

## Punte per utensili staccapunti

PUNTE SPECIALI PER MACCHINE STACCAPUNTI PNEUMATICHE. PERMETTONO LA PERFETTA FRESATURA DEI PUNTI DI SALDATURA PER IL DISTACCO DI LAMIERATI DANNEGGIATI DALLE CARROZZERIE DEGLI AUTOMEZZI. INDICATE PER L'UTILIZZO DA PARTE DI CARROZZIERI AUTO, MEZZI PESANTI E LATTONIERI.

### HSS Cobalt



- Punte per macchine staccapunti realizzate in acciaio HSS al cobalto, disponibili in varie misure. affilatura speciale con punta autocentrante.
- Indicate per acciai normali e spessori limitati. Ottime prestazioni e lunga durata.

Code	Desc.	Ø attacco mm	Ø Foratura mm	Length total mm
4770000250	25 - 6,5	8	6,5	40
4770000260	26 - 8	8	8,0	40
4770000262	26 - 44/8	8	8,0	44

### HSS cobalt with titanium aluminum nitride coating

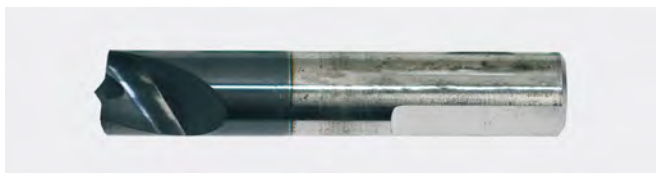

- Special tips for machines made staccapunti HSS with superficial titanium aluminum nitride. The distinctive bright blue coating replaces and enhances the classic treatment titanium color gold further enhancing the properties' lubricants, anti-seizure and anti-wear.
- Sharpening with special double-edged and self-centering tip.
- Indicated for the cutting of steels of medium and low hardness, high performance and speed 'of cut, long life.

Code	Desc.	Ø attacco mm	Ø Foratura mm	Length total mm
4770004870	346 - 6,5	8	6,5	44
4770004880	346 - 8	8	8,0	44

### Tips carbide for high-strength steels



- Carbide special drills, sharp treble and titanium aluminum nitride coating. indicated for the drilling of high-strength special steels (type usibor) currently used in special parts of the auto industry.
- These particular milling cutters are indicated for the drilling of longitudinal members, frames, front and rear cross where the HSS even do not scratch the material.
- Special sharpening, sharp treble, self-centering tip. Extreme performance and long life.

Code	Desc.	Ø attacco mm	Ø Foratura mm	Length total mm
4770004890	347 - 40	8	8,0	40
4770004900	347 - 44	8	8,0	44





## Drill bit to milling cutter to drool



- in HSS
- Used on metal, wood, plastic

Code	Desc.	Ø mm	Lt mm
4770000270	27	6.35-1/4	90

## Punte calcestruzzo SDS-Plus SPEEDHAMMER



- Nuova scanalatura; assicura la rimozione delle polveri diminuendo il rischio di intasamento.
- Nuova punta al carburo autocentrante, maggior rapidità di perforazione e minori vibrazioni.
- Per tutti i materiali quali calcestruzzo, ceramica, mattone, granito e marmo.

Code	Desc. Ø x L	L. screw mm
3260200100	4x110 mm	50
3260200110	5x110 mm	50
3260200120	6x110 mm	50
3260200130	7x110 mm	50
3260200140	8x110 mm	50
3260200150	10x110 mm	50
3260200160	5x160 mm	100
3260200170	6x160 mm	100
3260200175	6,5x160 mm	100
3260200180	7x160 mm	100
3260200190	8x160 mm	100
3260200193	9x210 mm	150
3260200195	9x160 mm	100
3260200200	10x160 mm	100
3260200300	11x160 mm	100
3260200400	12x160 mm	100
3260200450	13x160 mm	100
3260200500	14x160 mm	100
3260200550	15x160 mm	100
3260200650	6x210 mm	150
3260200700	8x210 mm	150
3260200750	10x210 mm	150
3260200800	12x210 mm	150
3260200850	14x210 mm	150
3260200950	16x210 mm	150
3260201000	18x210 mm	150
3260201050	20x210 mm	150
3260201090	6x260 mm	200
3260201100	8x260 mm	200
3260201150	10x260 mm	200
3260201200	12x260 mm	200
3260201250	14x260 mm	200
3260201300	15x260 mm	200
3260201400	18x260 mm	200
3260201500	8x410 mm	350
3260201550	10x410 mm	350
3260201600	12x410 mm	350
3260201650	14x410 mm	350
3260201700	16x410 mm	350
3260201750	18x410 mm	350
3260201800	20x410 mm	350
3260201850	22x410 mm	350
3260201900	25x410 mm	350
3260201950	14x610 mm	550
3260202000	16x610 mm	550
3260202050	18x610 mm	550
3260202100	20x610 mm	550
3260202150	22x610 mm	550
3260202250	14x1000 mm	940
3260202300	16x1000 mm	940
3260202350	18x1000 mm	940
3260202400	20x1000 mm	940
3260202450	22x1000 mm	940



## Assortment tips concrete SDS-Plus



- Assortment of tips for hammers with SDS-Plus in metal box
- CONTENT: 2 PCS. Ø 5x110; 2 PCS. Ø 6x110; 1 PZ. Ø 8x110; 1 PZ. Ø 6x160; 1 PZ. Ø 8x160; 1 PZ. Ø 10x160; 1 PZ. Ø 12x160

Code	Desc.
3261000100	512

4

## Punte a 4 taglienti per cemento armato SDS-Plus



Code	Desc.	Ø	Lung. Tot. L1	Lung. Utile L2
3260205000	5X110/4	5	110	50
3260205010	5X160/4	5	160	100
3260205020	6X110/4	6	110	50
3260205030	6X160/4	6	160	100
3260205040	6X210/4	6	210	150
3260205050	6X260/4	6	260	200
3260205060	6,5X160/4	6,5	160	100
3260205070	6,5X210/4	6,5	210	150
3260205075	6,5X260/4	6,5	260	200
3260205080	8X110/4	8	110	50
3260205090	8X160/4	8	160	100
3260205100	8X210/4	8	210	150
3260205110	8X260/4	8	260	200
3260205120	10X110/4	10	110	50
3260205130	10X160/4	10	160	100
3260205140	10X210/4	10	210	150
3260205150	10X260/4	10	260	200
3260205160	10X450/4	10	450	400
3260205170	12X160/4	12	160	100
3260205180	12X210/4	12	210	150
3260205190	12X260/4	12	260	200
3260205200	12X310/4	12	310	250
3260205210	12X450/4	12	450	400
3260205220	14X160/4	14	160	100
3260205230	14X210/4	14	210	150
3260205240	14X260/4	14	260	200
3260205250	14X450/4	14	450	400
3260205260	16x160/4	16	160	100
3260205270	16x210/4	16	210	150
3260205280	16x260/4	16	260	200
3260205290	16x450/4	16	450	400

- Punta a 4 taglienti con attacco SDS Plus.
- Ideale per forare il tondino in ferro del cemento armato. Fora anche: calcestruzzo, ceramica, mattone, granito e marmo.
- **Settore di utilizzo:** impiantisti elettricisti e termoidraulici, carpenteria, installazione scale e ringhiere, serramentisti.
- **Vantaggi:** perforazione del tondino nel cemento armato grazie alle 4 placche di materiale duro sulla testa.
- Testa a 4 taglienti appositamente studiata per creare una perforazione veloce.
- Vibrazioni in foratura limitate.
- Punta autocentrante per un centraggio immediato del foro.
- Scanalatura a spirale lungo la punta ideale per rimuovere velocemente grosse quantità di detriti.

## Concrete drills SDS-Max



- Four sharp spikes in Hartmetall.
- Ideal for masonry, concrete, natural and artificial stone.
- The head with four cutting edges allows a reduction in vibration by up to 50% with less fatigue for the operator.
- High speed 'drilling, higher hole accuracy and excellent centering.
- Suitable for all the hammers with SDS-Max.

Code	Desc. Ø X L tot. mm	L. screw mm
3260300010	12 x 740	600
3260300100	18 x 550	460
3260300200	20 x 550	460
3260300300	22 x 550	460
3260300400	24 x 550	460
3260300500	25 x 550	460
3260300700	28 x 550	460
3260300800	30 x 550	460
3260300900	32 x 550	460
3260301000	35 x 550	460
3260301410	28 x 670	550
3260301420	25 x 920	800
3260301425	32 x 920	800



## Chisels with SDS-Max



- Chisels suitable for all hammers with SDS-Max

Code	Desc.	Tipo scalpello
3260301500	10/PU	A PUNTA LUNGHEZZA 40 cm
3260301600	10/PI	PIATTO LUNGHEZZA 40 cm LARGHEZZA PUNTA 2,5 cm
3260301700	10/PL	PIATTO LUNGHEZZA 36 cm LARGHEZZA PUNTA 5 cm
3260301800	10/SG	SGORBIA LUNGHEZZA 30 cm LARGHEZZA 3 cm

## Bi-metal hole saws HSS



4

- To tooth pitch and variable.
- For the cutting of steel, iron, cast iron, aluminum, bronze, brass, wood, plastics, synthetic resins.

Code	Desc.	Ø mm	Ø pollici	Utilizzabili con albero
4430033000	379	14	9/15	443-380/382
4430033010	379	16	5/8	443-380/382
4430033020	379	17	11/16	443-380/382
4430033030	379	19	3/4	443-380/382
4430033040	379	21	13/16	443-380/382
4430033050	379	22	7/8	443-380/382
4430033060	379	24	15/16	443-380/382
4430033070	379	25	1	443-380/382
4430033080	379	27	1-1/16	443-380/382
4430033090	379	29	1-1/8	443-380/382
4430033100	379	30	1-3/16	443-380/382
4430033110	379	32	1-1/4	443-381
4430033120	379	33	1-5/16	443-381
4430033130	379	35	1-3/8	443-381
4430033140	379	37	1-7/16	443-381
4430033150	379	38	1-1/2	443-381
4430033160	379	40	1-9/16	443-381
4430033170	379	41	1-5/8	443-381
4430033180	379	43	1-11/16	443-381
4430033190	379	44	1-3/4	443-381
4430033200	379	46	1-3/16	443-381
4430033210	379	48	1-7/8	443-381
4430033220	379	51	2	443-381
4430033230	379	52	2-1/16	443-381
4430033240	379	54	2-1/8	443-381
4430033250	379	57	2-1/4	443-381
4430033260	379	59	2-5/16	443-381
4430033270	379	60	2-3/4	443-381
4430033280	379	64	2-1/2	443-381
4430033290	379	65	2-9/16	443-381
4430033300	379	67	2-5/8	443-381
4430033302	379	68	-	443-381
4430033310	379	70	2-3/4	443-381
4430033313	379	76	-	443-381
4430033315	379	79	3-1/8	443-381
4430033317	379	83	3-1/4	443-381
4430033320	379	86	3-3/8	443-381
4430033330	379	95	3-3/4	443-381
4430033340	379	105	4-1/8	443-381
4430033345	379	121	4-3/4	443-381
4430033348	379	127	5	443-381
4430033350	379	152	6	443-381

## Shafts Holesaw



- Shafts Holesaw
- With guide tip, for use with standard drills.
- Interchangeable with any other brand.

Code	Desc.	For saws	Stem mm
4430033600	382	DA ø 14 A ø 30	6,30

## Shafts Holesaw



- With guide tip, for use with standard drills.
- Interchangeable with any other brand.

Code	Desc.	For saws	Guide drill bit	Hexagon mm
4430033400	380	From ø14 to ø 30	ø 6,35	8,5



## Shafts Holesaw



- With guide tip, for use with standard drills.
- Interchangeable with any other brand.
- From  $\varnothing 32$  to  $\varnothing 152$

Code	Desc.	For saws	Guide drill bit	Hexagon mm
4430033500	381	DA $\varnothing 32$ A $\varnothing 152$	$\varnothing 6,35$	9,5

## Tip for trees Holesaw

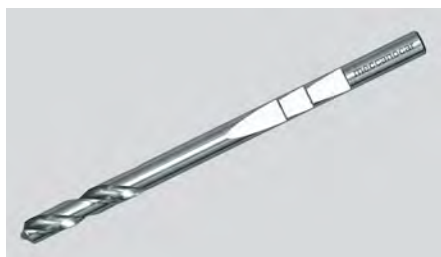

- Tips guide parts for items: 443-380 - 381-382.

Code	Desc.	Guide drill bit
4430033610	382-PD	$\varnothing 6,3 \times 115$
4430033608	382-PD	$\varnothing 6,35 \times 80$

## Assortment hole saws for plumbers



- Assortment in shockproof plastic case.
- Steel bimetal HSS.
- Complete with accessories.
- Contents: 6 saws:  $\varnothing 19$ ; 22; 29; 38; 44; 2 trees 57: 443-382; 443-381 1 adapter.

Code	Desc.
4430033700	383-ID

## Assortment hole saws for electricians



- Assortment in shockproof plastic case.
- Steel bimetal HSS.
- Complete with accessories.
- Contents: 6 Saws:  $\varnothing 22$ ; 29; 35; 44; 51; 2 trees 64: 443-382; 443-381 1 adapter.

Code	Desc.
4430033710	383-EL



## Assortment hole saws for installers



- Assortment in shockproof plastic case.
- Steel bimetal HSS.
- Complete with accessories.
- Contents: 9 saws: Ø 19; 22; 29; 35; 38; 44; 51; 57; 2 trees 64: 443-382; 443-381 1 Adapter 1 tip 443-382 PD.

Code	Desc.
4430033720	383-IN

## Cutters drills Saws HSS



SI CONSIGLIA UN BUON LUBROREFRIGERANTE COME N/S 411 00 01900 - 2605

**VELOCITA' DI TAGLIO CONSIGLIATE**

Ø FRESA	FERRO ACCIAIO	GHISA	LEGHE LEGGERE
12-17	400	360	1000
18-24	300	270	900
25-32	250	230	700
33-38	200	180	600
39-34	180	170	550
46-51	160	150	500
52-57	130	120	450
58-64	100	90	420
65-70	90	80	380
71-80	80	80	380
81-90	70	60	320
91-100	60	50	300

- For drilling steel sheets, iron and all metals up to a thickness of 4 mm - plastic lasts up to 8 mm.
- Not suitable for wood.
- Complete with stem and center-point.
- HRC 64.

Code	Desc. Ø	h mm	Stem	Drill pilot bit
4430046924	766-12	23	10	6x52
4430046926	766-13	23	10	6x52
4430046928	766-14	23	10	6x52
4430046930	766-15	23	10	6x52
4430046932	766-16	23	10	6x52
4430046934	766-17	23	10	6x52
4430046936	766-18	23	10	6x52
4430046940	766-19	23	10	6x52
4430046942	766-20	23	10	6x52
4430046944	766-21	23	10	6x52
4430046946	766-22	23	10	6x52
4430046948	766-23	23	10	6x52
4430046950	766-24	23	10	6x52
4430046952	766-25	23	10	6x52
4430046954	766-26	23	10	6x52
4430046956	766-27	23	10	6x52
4430046958	766-28	23	10	6x52
4430046960	766-29	23	10	6x52
4430046962	766-30	23	10	6x52
4430046970	766-31	23	10	6x52
4430046972	766-32	23	10	6x52
4430046974	766-33	23	10	6x52
4430046976	766-34	23	10	6x52
4430046978	766-35	23	10	6x52
4430046980	766-36	23	10	6x52
4430046982	766-37	23	10	6x52
4430046984	766-38	23	10	6x52
4430046986	766-39	23	10	6x52
4430046988	766-40	23	10	6x52
4430046990	766-41	23	10	6x52
4430046992	766-42	23	10	6x52
4430046994	766-43	23	10	6x52
4430046996	766-44	23	10	6x52
4430047000	766-45	23	10	6x52
4430047002	766-46	23	10	6x52
4430047004	766-47	23	10	6x52
4430047006	766-48	23	10	6x52
4430047008	766-49	23	10	6x52
4430047010	766-50	23	10	6x52
4430047012	766-51	23	12	6x52
4430047014	766-52	23	12	6x52
4430047016	766-53	23	12	6x52
4430047020	766-55	23	12	6x52
4430047022	766-56	23	12	6x52
4430047024	766-57	23	12	6x52
4430047026	766-58	23	12	6x52
4430047028	766-59	23	12	6x52
4430047030	766-60	23	12	6x52
4430047032	766-65	25	12	6x52
4430047034	766-70	25	12	6x52
4430047036	766-75	25	12	6x52
4430047038	766-80	25	12	6x52
4430047040	766-85	25	12	6x52
4430047042	766-90	25	12	6x52
4430047044	766-95	25	12	6x52
4430047046	766-100	25	12	6x52



### Shank for hole saws



Code	Desc.	For milling machines	Thread M	D
4430047048	772-G1	FROM $\varnothing$ 15 TO $\varnothing$ 50	12x1,25	10
4430047050	772-G2	FROM $\varnothing$ 51 TO $\varnothing$ 100	16x1,5	12

### Tips pilot



Code	Desc.	For milling machines	DxL
4430047052	772-PU1	FROM $\varnothing$ 12 TO $\varnothing$ 100	6x52

### Extensions for cutters



Code	Desc.	For milling machines	Length mm	Thread M	D
4430047056	772-PR1	FROM $\varnothing$ 15 TO $\varnothing$ 50	400	12x1,25	13
4430047058	772-PR2	FROM $\varnothing$ 51 TO $\varnothing$ 100	400	16x1,5	13

## Males hand series 3 pieces

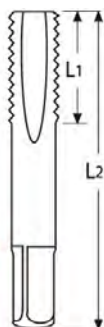

**IN ACCIAIO AL CROMO VANADIO**

**IN ACCIAIO HSS-G**

- Metric coarse (MA).
- Chromium-vanadium UNI 4535.
- HSS-G DIN 352 (high quality '- adjusted).
- Each series' consists of a male roughing, intermediate from a male and a male finisher.
- Chrome steel vanadium

Code	Desc.	Measure	L1 mm	L2 mm	Type
4430030400	367/3	3x0.5	12	40	ACC. AL C.V.
4430030410	367/3	4x0.7	14	45	ACC. AL C.V.
4430030420	367/3	5x0.8	16	48	ACC. AL C.V.
4430030430	367/3	6x1	18	50	ACC. AL C.V.
4430030440	367/3	7x1	18	50	ACC. AL C.V.
4430030450	367/3	8x1.25	22	56	ACC. AL C.V.
4430030460	367/3	9x1.25	22	63	ACC. AL C.V.
4430030490	367/3	10x1.5	25	70	ACC. AL C.V.
4430030520	367/3	12x1.75	30	75	ACC. AL C.V.
4430030540	367/3	14x2	32	80	ACC. AL C.V.
4430030560	367/3	16x2	32	80	ACC. AL C.V.
4430030570	367/3	18x2.5	40	95	ACC. AL C.V.
4430030590	367/3	20x2.5	40	95	ACC. AL C.V.
4430030600	367/3	22x2.5	40	100	ACC. AL C.V.
4430030610	367/3	24x3	50	110	ACC. AL C.V.
4430047950	871/3	4x0.7	14	45	HSS-G
4430047960	871/3	5x0.8	16	48	HSS-G
4430047970	871/3	6x1	18	50	HSS-G
4430047980	871/3	7x1	18	50	HSS-G
4430047990	871/3	8x1.25	22	56	HSS-G
4430048000	871/3	9x1.25	22	63	HSS-G
4430048010	871/3	10x1.5	25	70	HSS-G
4430048020	871/3	12x1.75	30	75	HSS-G
4430048030	871/3	14x2	32	80	HSS-G
4430048040	871/3	16x2	32	80	HSS-G
4430048050	871/3	18x2.5	40	95	HSS-G
4430048060	871/3	20x2.5	40	95	HSS-G



## Males Hand Series 2 parts

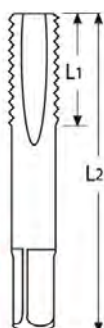

**IN ACCIAIO AL CROMO VANADIO**

**IN ACCIAIO HSS-G**

- Metric coarse and fine.
- Chrome-vanadium UNI 4535.
- HSS-G DIN 2182 (quality-adjusted).
- Each series is composed of a male roughing mill and by a male finisher.

Code	Desc.	Measure	L1 mm	L2 mm	Type
4430030000	366/2	3x0.5	12	40	Chrome steel vanadium
4430030020	366/2	4x0.7	14	45	Chrome steel vanadium
4430030035	366/2	5x0.8	16	48	Chrome steel vanadium
4430030040	366/2	6x0.75	18	50	Chrome steel vanadium
4430030050	366/2	6x1	18	50	Chrome steel vanadium
4430030060	366/2	7x1	18	50	Chrome steel vanadium
4430030070	366/2	8x1	22	56	Chrome steel vanadium
4430030080	366/2	8x1.25	22	56	Chrome steel vanadium
4430030090	366/2	9x1	22	63	Chrome steel vanadium
4430030100	366/2	10x1	25	70	Chrome steel vanadium
4430030110	366/2	10x1.25	25	70	Chrome steel vanadium
4430030120	366/2	10x1.5	25	70	Chrome steel vanadium
4430030130	366/2	12x1.25	30	75	Chrome steel vanadium
4430030140	366/2	12x1.5	30	75	Chrome steel vanadium
4430030145	366/2	12x1.75	30	75	Chrome steel vanadium
4430030150	366/2	14x1.25	32	80	Chrome steel vanadium
4430030160	366/2	14x1.5	32	80	Chrome steel vanadium
4430030170	366/2	14x2	32	80	Chrome steel vanadium
4430030180	366/2	16x1.5	32	80	Chrome steel vanadium
4430030190	366/2	16x2	32	80	Chrome steel vanadium
4430030210	366/2	18x2	40	95	Chrome steel vanadium
4430030230	366/2	20x1.5	40	95	Chrome steel vanadium
4430030260	366/2	22x1.5	40	100	Chrome steel vanadium
4430030290	366/2	24x1.5	50	110	Chrome steel vanadium
4430030300	366/2	24x2	50	110	Chrome steel vanadium
4430048100	872/2	10x1.25	18	63	HSS-G
4430048110	872/2	12x1.25	20	70	HSS-G
4430048120	872/2	12x1.5	20	70	HSS-G
4430048130	872/2	14x1.5	20	70	HSS-G
4430048140	872/2	16x1.5	20	70	HSS-G
4430048150	872/2	18x1.5	22	80	HSS-G
4430048160	872/2	20x1.5	22	80	HSS-G



## Males hand series 3 pieces UNC

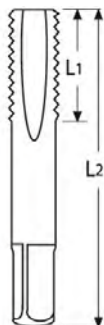

Code	Desc.	N. threads per inch	L1 mm	L2 mm
4430030700	368/3-1/4"	20	30	70
4430030710	368/3-5/16"	18	30	70
4430030720	368/3-3/8"	16	35	75
4430030730	368/3-7/16"	14	40	80
4430030740	368/3-1/2"	13	45	85
4430030750	368/3-9/16"	12	45	90
4430030760	368/3-5/8"	11	47	100
4430030770	368/3-3/4"	10	50	110

- American thread coarse (UNC).
- Chrome steel vanadium ANSI B 1-1.
- Each series' consists of a male roughing, intermediate from a male and a male finisher.

## Males Hand Series 2 pieces UNF

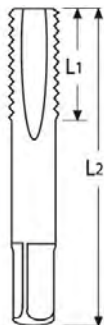

Code	Desc.	N. threads per inch	L1 mm	L2 mm
4430030800	368/2-1/4"	28	30	70
4430030810	368/2-5/16"	24	30	70
4430030820	368/2-3/8"	24	35	75
4430030830	368/2-7/16"	20	40	80
4430030840	368/2-1/2"	20	45	85
4430030850	368/2-9/16"	18	45	90
4430030860	368/2-5/8"	18	47	100
4430030870	368/2-3/4"	16	50	110

- American thread with fine pitch (UNF).
- Chrome-vanadium ANSI B 1-1.
- Each series' consists of a male and a roughing male finisher.

## Males Hand Series 2 pieces GAS

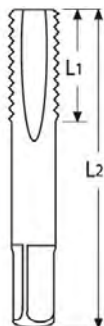

Code	Desc.	N. threads per inch	L1 mm	L2 mm
4430030620	368/2-1/8"	28	18	65
4430030625	368/2-1/4"	19	24	70
4430030630	368/2-3/8"	19	25	75
4430030635	368/2-1/2"	14	31	80
4430030640	368/2-3/4"	14	33	90
4430030645	368/2-1"	11	39	100

- Cylindrical gas thread.
- Chrome-vanadium UNI 1338 - DIN 353.
- Each series' consists of a male and a roughing male finisher.

## Males hand claims series 3 pieces

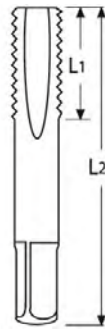

Code	Desc.	L1 mm	L2 mm
4430030322	367 SX - 3/4x0.7	13	45
4430030324	367 SX - 3/5x0.8	16	50
4430030326	367 SX - 3/6x1	19	50
4430030328	367 SX - 3/8x1.25	20	56
4430030330	367 SX - 3/10x1.5	22	70
4430030332	367 SX - 3/12x1.75	24	75

- HSS.
- Thread stripped and ground.
- Each series' consists of a male roughing, intermediate and a male a male finisher.
- For left-hand threads.

## Machine taps HSS-G for through holes



**CON GAMBO RINFORZATO  
A NORME ISO 2/6H, DIN  
371/B E 376/B**

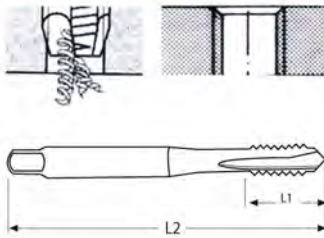

- Machine taps HSS-G to make threads in one pass through steel, cast iron, non-ferrous metals.
- Straight flute, spiral point, reinforced shank diameter up to 10 mm., Shank for measures more 'large.
- Metric thread to ISO 2 / 6H. Construction according to DIN 371 / B and 376 / B.
- To use it is recommended lubrication with our cutting oils cod. 411 00 01900 spray, 411 00 14860 liquid.
- \* DIN 376 with reduced shank.

Code	Desc.	Thread	L2 mm leng. tot. mm	L1 leng. thread mm	Ø stem (mm)
4430051080	1038/3	M 3x0,5	56	11	3,5
4430051090	1038/4	M 4x0,7	63	13	4,5
4430051100	1038/5	M 5x0,8	70	16	6,0
4430051110	1038/6	M 6x1	80	19	6,0
4430051120	1038/8	M 8x1,25	90	22	8,0
4430051130	1038/10x1,5	M 10x1,5	100	24	10
4430051140	1038/10x1,25	M 10x1,25	100	24	10
4430051150	1038/12*	M12x1,75	110	29	9
4430051160	1038/14*	M 14x2	110	30	11
4430051170	1038/16*	M 16x2	110	30	12
4430051810	1062/18*	M 18 X 2,5	125	34	14
4430051820	1062/20*	M 20 X 2,5	140	34	16
4430051830	1062/22*	M 22 X 2,5	140	34	18



## Machine taps HSS-G for blind holes



- Machine taps HSS-G for blind holes
- Machine taps HSS-G to make threads in blind holes in one pass on steel, cast iron, non-ferrous metals.
- Helical grooves inclined at 35 °, chamfer "C", reinforced shank diameter up to 10 mm., Shank for measures more 'large.
- Metric thread to ISO 2 / 6H. Construction according to DIN 371 / C-35 ° and 376 / C-35 °.
- To use it is recommended lubrication with our cutting oils cod. 411 00 01900 spray, 411 00 14860 liquid.
- \* Type DIN 376 with reduced shank.

Code	Desc.	Thread	L2 mm leng. tot. mm	L1 leng. thread mm	Ø stem (mm)
4430051300	956/3	M 3x0,5	56	11	3,5
4430051310	956/4	M 4x0,7	63	13	4,0
4430051320	956/5	M 5x0,8	70	16	6,0
4430051330	956/6	M 6x1	80	19	6,0
4430051340	956/8	M 8x1,25	90	22	8,0
4430051350	956/10	M 10x1,5	100	24	10,0
4430051360	956/12*	M 12x1,75	110	25	9

## Machine taps HSS-co for steel-Through holes

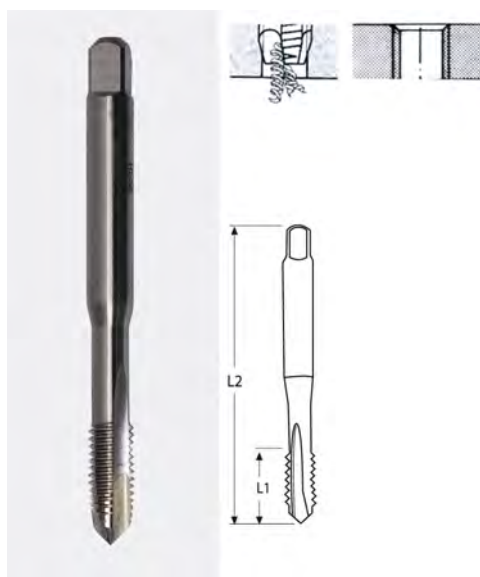

- Machine taps HSS-CO to make thread loops in single pass of stainless steels, cast iron, non-ferrous metals.
- Straight flutes and spiral point.
- Reinforced shank up to 10 mm dia., Shank for measures more 'large.
- Metric thread to ISO 2 / 6H. construction according to DIN 371 / B and 376 / B.
- To use it is recommended lubrication with our cutting oils cod.411 00 sray 01900, 4110014860 liquid.
- \* Type DIN 376 with reduced shank

Code	Desc.	Thread	L2 mm leng. tot. mm	L1 leng. thread mm	Ø gambo mm
4430054280	1113/3	M3X0,5	56	11	3,5
4430054290	1113/4	M4X0,7	63	13	4,5
4430054300	1113/5	M5X0,8	70	16	6,0
4430054310	1113/6	M6X1	80	19	6,0
4430054320	1113/8	M8X1,25	90	22	8,0
4430054330	1113/10	M10X1,5	100	24	10
4430054340	1113/12*	M12X1,75	110	29	9
4430054350	1113/14*	M14X2	110	30	11
4430054360	1113/16*	M16X2	110	30	12
4430054370	1113/18*	M18X2,5	125	34	14

## Machine taps HSS-co for steel-blind holes

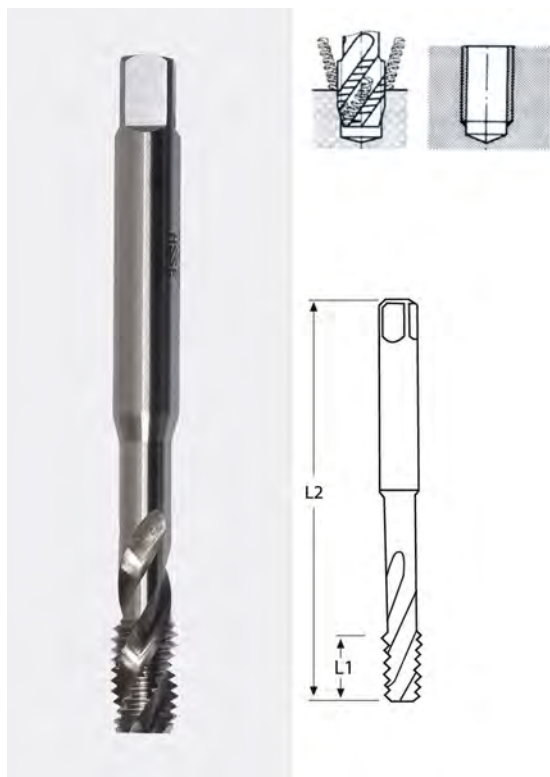

- Machine taps in HSS-co for making threads in blind holes in single pass of stainless steels, cast iron, non-ferrous metals.
- Helical grooves inclined at 35 °, chamfer "C".
- Reinforced shank up to 10 mm dia., Shank for measures more 'large.
- Metric thread to ISO 2 / 6H. Construction according to DIN 371 / C-35 ° and 376 / C-35 °.
- To use it is recommended lubrication with our cutting oils cod.4110001900 spray, 4110014860 liquid.
- \* Type DIN 376 with reduced shank.



Code	Desc.	Thread	L2 mm <i>leng. tot. mm</i>	L1 leng. <i>thread mm</i>	Ø gambo <i>mm</i>
4430054400	1114/3	M3X0,5	56	11	3,5
4430054410	1114/4	M4X0,7	63	13	4,5
4430054420	1114/5	M5X0,8	70	16	6,0
4430054430	1114/6	M6X1	80	19	6,0
4430054440	1114/8	M8X1,25	90	22	8,0
4430054450	1114/10	M10X1,5	100	24	10
4430054460	1114/12*	M12X1,75	110	25	9
4430054470	1114/14*	M14X2	110	25	11
4430054480	1114/16*	M16X2	110	28	12
4430054490	1114/18*	M18X2,5	125	32	14
4430054500	1114/20*	M20X2,5	140	32	16
4430054510	1114/22*	M22X2,5	140	32	18

## Special tips for drilling and tapping

- Metric coarse (MA).
- HSS-CO high yield.

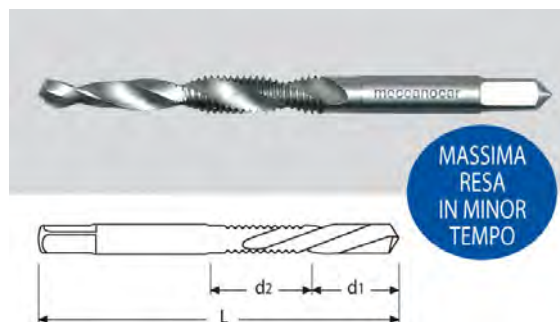

Code	Desc.	Ø mm	L <i>mm</i>	d1 <i>mm</i>	d2 mm
4430046912	765	4x0.7	63	3.3	4
4430046914	765	5x0.8	71	4.2	5
4430046916	765	6x1	80	5	6
4430046918	765	8x1.25	95	6.8	8
4430046920	765	10x1.5	106	8.5	10
4430046922	765	12x1.75	125	10.2	12

## Drills combined HSS-G 1/4 "Drilling, threading and countersink

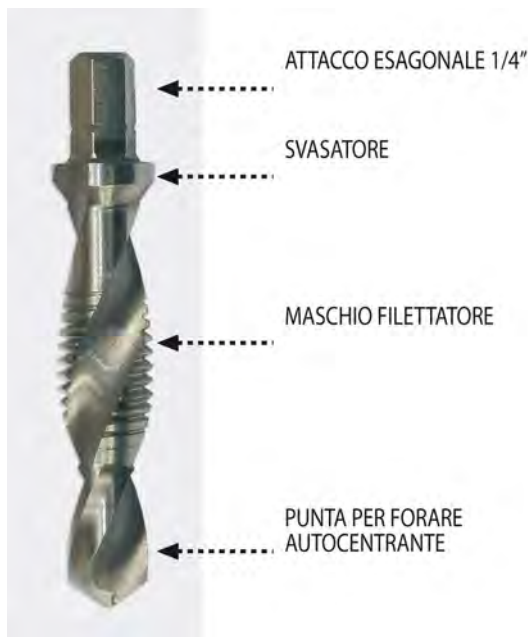

- Tools adjusted HSS-G.
- ISO metric, coarse thread.
- Drilling, threading and flaring steel, aluminum, non-ferrous metals in general, plastic.
- Maximum workable thickness equal to the diameter of the tip, for example: M8 and 'usable on a maximum workable thickness of 8mm.
- Due to its shape are reduced processing times, 'cause in only one tool the user can' drill, thread and countersink.
- Use sectors: electrical and plumbing and heating plant engineer, coachwork, workshops vehicles.
- 1/4 "hexagonal wrenches, cordless drills, portable drills and stationary.
- For use with our cut oil tap cod. 4110001900 and oil to thread cod. 4110015590.

Code	Desc.	Attachment esag.	Length mm	MxPace
4430055510	1290	1/4"	36	M3x0,5
4430055515	1295	1/4"	39	M4x0,7
4430055520	1300	1/4"	41	M5x0,8
4430055525	1305	1/4"	44	M6x1
4430055530	1310	1/4"	50	M8x1,25
4430055535	1315	1/4"	59	M10x1,5

## Assortment tips combined HSS-G 1/4 "Drilling, threading and countersink



- Assortment tips combined with 1/4 "including magnetic bit holder for 1/4".
- For use with our cut oil tap cod. 4110001900 and oil to thread cod. 4110015590.

Code	Desc.	Content	Attachment esag.
4430055540	1330	1 port bits 1 PZ. M3x0.5 1 PZ. M4X0,7 1 PZ. M5x0.8 1 PZ. M6X1 1 PZ. M8x1,25 1 PZ. M10x1,5	1/4"



## Series taps drills with reversible



- Metric coarse (MA).
- HSS-G.
- 1/4 "hexagonal.

Code	Desc.	Content
4430046900	760	1MALE FOR TYPE M 3; 4; 5; 6X1 8X1.25; 10X1.5

## Round dies in metric



- Made of chrome-vanadium.
- UNI 4535.

Code	Desc.	Big pitch	Fine pitch	Ø est.
4430030900	369	3X0.5	-	25.4
4430030920	369	4X0.7	-	25.4
4430030940	369	5X0.8	-	25.4
4430030950	369	-	6X0.75	25.4
4430030960	369	6X1	-	25.4
4430030980	369	7X1	-	25.4
4430031000	369	-	8X1	25.4
4430031010	369	8X1.25	-	25.4
4430031020	369	-	9X1	25.4
4430031030	369	9X1.25	-	25.4
4430031050	369	-	10X1	38.1
4430031060	369	-	10X1.25	38.1
4430031070	369	10X1.5	-	38.1
4430031100	369	-	12X1.25	38.1
4430031110	369	-	12X1.5	38.1
4430031120	369	12X1.75	-	38.1
4430031150	369	-	14X1.25	38.1
4430031160	369	-	14X1.5	38.1
4430031170	369	14X2	-	38.1
4430031210	369	-	16X1.5	38.1
4430031220	369	16X2	-	38.1
4430031250	369	-	18X1.5	38.1
4430031255	369	-	18X2	50.8
4430031260	369	18X2.5	-	50.8
4430031280	369	-	20X1.5	50.8
4430031300	369	20X2.5	-	50.8
4430031320	369	-	22X1.5	50.8
4430031340	369	22X2.5	-	50.8
4430031360	369	-	24X1.5	50.8
4430031370	369	-	24X2	50.8
4430031380	369	24X3	-	50.8



## Round dies in metric thread HSS



Code	Desc.	Big pitch	Fine pitch	Ø est. per h
4430048200	873	4X0.7	-	20x5
4430048210	873	5X0.8	-	20x7
4430048220	873	6X1	-	20x7
4430048230	873	7X1	-	25x9
4430048240	873	8X1.25	-	25x9
4430048250	873	9X1.25	-	25x9
4430048260	873	-	10X1.25	30x11
4430048270	873	10X1.5	-	30x11
4430048280	873	-	12X1.25	38x10
4430048290	873	-	12X1.5	38x10
4430048300	873	12X1.75	-	38x14
4430048310	873	-	14X1.5	38x10
4430048320	873	14X2	-	38x14
4430048330	873	-	16X1.5	45x14
4430048340	873	16X2	-	45x18
4430048350	873	-	18X1.5	45x14
4430048360	873	18X2.5	-	45x18
4430048370	873	-	20X1.5	45x14
4430048380	873	20X2.5	-	45x18

- Steel high quality 'HSS.
- DIN 223.
- With spiral point.

## Round dies - American thread coarse UNC



- Made of chrome - vanadium.

Code	Desc.	N. threads per inch	Ø est.
4430031400	370-1/4"	20	25.4
4430031410	370-5/16"	18	25.4
4430031420	370-3/8"	16	38.1
4430031430	370-7/16"	14	38.1
4430031440	370-1/2"	13	38.1
4430031450	370-9/16"	12	38.1
4430031460	370-5/8"	11	50.8
4430031470	370-3/4"	10	50.8
4430031480	370-7/8"	9	50.8
4430031490	370-1"	8	50.8

## Round dies - American thread fine pitch UNF



- Made of chrome-vanadium.

Code	Desc.	N. threads per inch	Ø est.
4430031500	370-1/4"	28	25.4
4430031510	370-5/16"	24	25.4
4430031520	370-3/8"	24	38.1
4430031530	370-7/16"	20	38.1
4430031540	370-1/2"	20	38.1
4430031550	370-9/16"	18	38.1
4430031560	370-5/8"	18	50.8
4430031570	370-3/4"	16	50.8
4430031580	370-7/8"	14	50.8
4430031590	370-1"	12	50.8

## Round dies - cylindrical gas thread BSP



- Made of chrome-vanadium 338 UNI.

Code	Desc.	N. threads per inch	Ø est.
4430031592	370-1/8"	28	38.1
4430031593	370-1/4"	19	38.1
4430031594	370-3/8"	19	50.8
4430031595	370-1/2"	14	50.8
4430031597	370-3/4"	14	50.8
4430031598	370-1"	11	63.5

## Round dies - left hand thread



- In HSS.
- ISO metric thread - DIN 13 - M.

Code	Desc.	Ø est. per h
4430031392	369SX-3x0.5	20X5
4430031393	369SX-4x0.7	20X5
4430031394	369SX-5x0.8	20X7
4430031395	369SX-6x1	20X7
4430031396	369SX-8x1.25	25X9
4430031397	369SX-10x1.5	30X11
4430031398	369SX-12x1.75	38X14

## Tap wrenches extensible



- Pressed steel.
- American model DIN 814.

Code	Desc.	Maschi metrici	Maschi pollici	Males gas	L mm
4430031700	372-0	M1÷8	1/16÷1/4	-	130
4430031710	372-1	M1÷10	1/16÷3/8	1/8	188
4430031720	372-2	M4÷12	5/32÷1/2	1/8	280
4430031730	372-3	M5÷20	7/32÷3/4	1/8÷1/2	380
4430031740	372-4	M11÷27	7/16÷1	1/4÷3/4	500
4430031750	372-5	M13÷32	1/2÷1-1/4	1/4÷1	700
4430031760	372-6	M18÷42	3/4÷1-1/4	1/2÷1-1/4	1000

## Tap wrenches universal type Goodel



- With steel spindle with 4 jaws.
- Zinc-plating with reinforced protection.

Code	Desc.	Maschi metrici	L mm
4430031610	371-1	M2÷5	80
4430031620	371-2	M5÷7	90
4430031630	371-3	M7÷9	100
4430031640	371-4	M9÷12	100

**Universal tap wrenches ratchet short series**

- Reversible.
- Chromed steel.

Code	Desc.	Maschi metrici	Maschi pollici	L mm
4430031900	374-1	M3÷10	1/8÷3/8	85
4430031910	374-2	M5÷12	7/32÷1/2	100

4

**Universal ratchet tap wrenches, long series**

- Reversible.
- Chromed steel.

Code	Desc.	Maschi metrici	Maschi pollici	L mm
4430032000	375-1	M3÷10	1/8÷3/8	250
4430032001	375-2	M5÷12	7/32÷1/2	300

**Brings dies for round dies**

Code	Desc.	Ø per filiere	L mm
4430031800	373	20.6	200
4430031810	373	25.4	224
4430031820	373	38.1	315
4430031830	373	50.8	560
4430031845	373	20x7	200
4430031850	373	25x9	224
4430031855	373	30x11	280
4430031860	373	38x10	315
4430031865	373	38x14	315
4430031870	373	45x14	450

- Pressed steel and painted.
- DIN 225.
- With the adjustment screws.

## Annular tube



- With two set screws.
- Complete auction.

Code	Desc.	Ø per filiere	L mm
4430042610	476-2	25.4-38.1	190
4430042620	476-3	38.1-50.8	215

4

## Assortimento a filettare metrico per autofficine in HSS-G



- With taps and dies steel hss-g
- In sturdy wooden
- Male Series 3 pcs. (but step)
- Series male 2 pcs. (step mb)
- Contents: Series 3 pcs. : 3x0.5 m; 4x0.7; 5x0.8; 6x1; 7x1; 8x1.25; 10x1.5; 12x1.75; 14x2; 16x2 series 2 pcs. : 8x1 m; 10x1.25; 12x1.25; 12x1.5; 14x1.25; 14x1.5; 16x1.5 Dies round: 3x0.5 m; 4x0.7; 5x0.8; 6x1; 7x1; 8x1; 8x1.25; 10x1.25; 10x1.5; 12x1.25; 12x1.5; 12x1.75; 14x1.25; 14x1.5; 14x2; 16x1.5; 16x2 5 Annular round: 20x7 m; 25x9; 30x11; 38x14; 45x18 2 extensible tap wrench: 2-10 m; 5-21 - 1 tap wrench "T": m 3 ÷ 8

Code	Desc.
4203400750	6016

## Assortment for threading metric HSS-G 3-20



- Assortment of taps and dies HSS-G for the construction of male and female threads from diameter 3 to 20 mm diameter, coarse MA.
- Especially dedicated to industries, garage, maintenance, etc.
- Metal box full of males, dies, sends males, door chains, pitch gauge.
- Content: Males in three passes: M4- M3-M5-M6-M8-M10-M12-M16-M18-M20 M14-. Dies: M4- M3-M5-M6-M8-M10-M12-M16-M18-M20 M14-. # 2 sends males primer: M2-10, M5-21. # 2 sends males extensible: M1- 10, M11-27. # 6 die holder: 20X5, 20x7, 25X9, 30X11, 38X14, 45X18. # 1 screwdriver. # 1 pitch gauge Metric / Whitworth.

Code	Desc.
4203400800	6020



## Assortment thread type Fiat



- Round dies girautensili.
- Metric coarse and fine.
- UNI 4535.
- Taps and dies made of chrome-vanadium.
- Contents: Male series 2 pcs.: 2x0.4 m; 3x0.5; 4x0.7; 5x0.8 6x0.75; 6x1; 7x0.75; 7x1; 8x0.75; 8x1; 8x1.25; 9x0.75 9x1; 9x1.25; 10x0.75; 10x1; 10x1.25; 10x1.5 11x0.75; 11x1; 11x1.25; 11x1.5; 12x0.75; 12x1 12x1.25; 12x1.5; 12x1.75; 14x1; 14x1.25 14x1.5; 14x2; 16x1; 16x1.5; 16x2; 18x1.5 Dies round: m 25.4 (14) 38.1 (21) Annular round 2: 25.4 m; 38.1 2 Tap wrenches: 1-10 m m5-20; 1 tap wrench "T": 3-8 m.

Code	Desc.
4203400100	5990/2

## Assortment Thread metric for industries



- With taps and dies HSS-G DIN.
- In metal box.
- Content: HSS-G DIN 352 series 3 pcs.: M 3; 4; 5; 6; 8; 10; 12 Round Dies HSS-G DIN 223: M 3; 4; 5; 6; 8; 10; 12 5 Annular round DIN 225: M 20x5; 20x7; 25x9; 30x11; 38x14 2 tap wrench DIN 1814: M 10.01; 4-12 1 tap wrench "T": 3-10 M; 1 Screwdriver; 1 pitch gauges 7 drills HSS DIN 338 ø: M 05.02; 3.3; 4.2; 5; 6.8; 8.5; 10.2.

Code	Desc.
4203400700	6000

## Assortment threading UNC and UNF



- In a wooden box.
- With males in series of 2 and 3 pieces.
- Round dies and girautensili.
- American thread UNC-UNF.
- Taps and dies made of chrome-vanadium.
- UNC content: Males: M 04.01; 5/16; 3/8; 7/16; 1/2; 9/16; 5/8; 3/4.
- UNF content: Dies round: M 25.04; 38.1; 50.8 3 Annular round: M 04.25; 38.1; 50.8 2 tap wrench: M 01.16 ÷ 03.08; 7/32 ÷ 3/4.

Code	Desc.
4203400300	5994/4 UNC
4203400400	5995/5 UNF

## Drills in HSS



- To drill and widen plate or tubing from 3 to 50 mm
- For steel, stainless steel, iron, cast iron and plastic
- With center drill

VELOCITA' DI TAGLIO CONSIGLIATE (g/min.)

GRANDEZZA	ACCIAI DURI INOX	ACCIAIO DOLCE	LEGHE LEGGERE	PLASTICA
0	600 - 400	800 - 500	2000 - 1500	3000 - 2000
1	400 - 200	600 - 300	1500 - 800	2000 - 1500
2	200 - 100	400 - 200	1000 - 500	1500 - 1000
3	100 - 80	300 - 150	500 - 300	1000 - 500
4	80 - 50	200 - 100	300 - 200	500 - 200

SI CONSIGLIA DI LUBRIFICARE CON NS. COD. 420 44 00500 - SYS  
PASTA LUBRIFICANTE O NS. COD. 411 00 01900 - 2605 CUT OIL TAR,  
OLIO DA TAGLIO

Code	Desc.	Cutting capacity mm	Stem mm	Lt mm
4204400200	0	3 - 14	6	58
4204400300	1	6 - 20	8	63
4204400400	2	16 - 30,5	10	79
4204400410	3	26 - 40	13	86
4204400420	4	36 - 50	13	90

## Assortment Drills



- Contents: No. 1 cutter 3-14; n ° 1 cutter 6-20; n ° 1 cutter 26 - 40; No. 1 lubricating paste.

Code	Desc.
4204400100	A 3

## Tapered drill Hss



- Specific to enlarge holes in sheet.
- Ideal for mechanics, motor vehicle electricians and repairers generally.

Code	Desc.	Cutting capacity mm	Ls mm
4204400600	025	0 - 25	40

## Tapered Drill stepped HSS-G with helical cutting edges



- Ideal for drilling and enlarge holes on plates in steel, iron, aluminum, brass and plastic.
- Use sectors: electrical, plumbing, maintenance, window fitters, workshops and body shops.
- To work on sheets up to a thickness of 5 mm.
- A self-centering tip for immediate centering of the hole.
- Helical groove that quickly eliminates the chip during processing.

**Velocità di taglio consigliate (g/min)**

CODICE	OTONE				
	ACCIAIO	FRAGILE	TENACE	LEGGERE	PLASTICA
477 00 05755	1200	2400	1400	1200	1400
477 00 05760	800	1600	920	800	920
477 00 05765	560	1100	650	560	650
477 00 05770	450	900	530	450	530

Code	Desc.	Cutting capacity mm	Ø gambo mm	Leng. mm	N. steps
4770005755	700/4-12	4-12	6	80	9
4770005760	700/4-20	4-20	9	70	9
4770005765	700/4-30	4-30	10	97	13
4770005770	700/4-39	4-39	10	107	13

## Tapered Drill step in HSS



- To drill and widen sheets from 4 to 30mm.
- Fast cutting, high performance.

**VELOCITÀ DI TAGLIO CONSIGLIATE (g/min.)**

ACCIAI DURI INOX	ACCIAIO DOLCE	LEGHE LEGGERE	PLASTICA
50 - 300	80 - 500	200 - 1000	500 - 1500

SI CONSIGLIA DI LUBRIFICARE CON NS. COD. 420 44 00500 - SYS.  
PASTA LUBRIFICANTE O NS. COD. 411 00 01900 - 2605 CUT OIL TAP.  
OLIO DA TAGLIO.

Code	Desc.	Cutting capacity mm	Stem mm	Lt mm
4770000280	28	4 - 30	10	75

## Step drills measures "ISO-PG"



- Drill bits and widen hardened steel with molybdenum.
- Ideal for drilling steel, copper, brass, aluminum, plastic, laminates, wood.
- PG measures for panel builders and electricians.

Code	Desc.	D. Holes mm	N. steps	H. step mm	Stem mm
4430049810	965	6-30,5	7	2,5	13

## Countersinks 90 ° in three cutting edges



- Fully adjusted machining with less vibration deburring and countersink perfect speed 'high processing.
- Countersink HSS-G at 90 ° DIN 335 C. For deburring and countersink holes of alloy and non-alloy aluminum sheet also coated steel, pipes, profiles and Plexiglas up to a thickness of 5 mm.
- Running three sharp fully rectified, provide machining with less vibration, a perfect finish, excellent chipping, and a speed 'high processing.
- Available in standard (HSS) and reporting to titanium (HSS-TIN) for durability and occasional use of stainless steel.
- To use it is recommended lubrication with our cutting oils cod. 411 00 01900 spray, 411 00 14860 liquid.



Code	Desc.	Ø svasat. mm	For screws TPS Ø	Length mm	Ø stem (mm)	Type
4430051400	1039/6,3	6,3	M3	44	5	COUNTERSINKS HSS DIN335C -90 °
4430051410	1039/8,3	8,3	M4	50	6	COUNTERSINKS HSS DIN335C -90 °
4430051420	1039/10,4	10,4	M5	54	6	COUNTERSINKS HSS DIN335C -90 °
4430051430	1039/12,4	12,4	M6	54	8	COUNTERSINKS HSS DIN335C -90 °
4430051440	1039/16,5	16,5	M8	60	10	COUNTERSINKS HSS DIN335C -90 °
4430051450	1039/20,5	20,5	M10	63	10	COUNTERSINKS HSS DIN335C -90 °
4430051460	1039/25	25	M12	66	10	COUNTERSINKS HSS DIN335C -90 °
4430051470	1039/31	31	M16	71	13	COUNTERSINKS HSS DIN335C -90 °
4430051500	1040/6,3	6,3	M3	44	5	COUNTERSINKS HSS DIN335C -90 °
4430051510	1040/8,3	8,3	M4	50	6	COUNTERSINKS HSS DIN335C -90 °
4430051520	1040/10,4	10,4	M5	54	6	COUNTERSINKS HSS DIN335C -90 °
4430051530	1040/12,4	12,4	M6	54	8	COUNTERSINKS HSS DIN335C -90 °
4430051540	1040/16,5	16,5	M8	60	10	COUNTERSINKS HSS DIN335C -90 °
4430051550	1040/20,5	20,5	M10	63	10	COUNTERSINKS HSS DIN335C -90 °
4430051560	1040/25	25	M12	66	10	COUNTERSINKS HSS DIN335C -90 °
4430051570	1040/31	31	M16	71	13	COUNTERSINKS HSS DIN335C -90 °

## Assortment countersink 90 ° with three sharp



Code	Desc.	Tipo di svasatori din 335C-90°	Content
4430051480	1042	HSS	6,3 - 8,3 - 10,4 - 12,4 - 16,5 - 20,5
4430051580	1043	HSS-TIN	6,3 - 8,3 - 10,4 - 12,4 - 16,5 - 20,5

## Countersinks 90 ° with three sharp 1/4 "hexagonal



PER L'UTILIZZO  
SU TRAPANI  
AVVITATORI O SU  
PORTA BITS

- Fully adjusted machining with less vibration deburring and countersink perfect speed 'high processing.
- Countersink HSS-G at 90 ° DIN 335 C. For deburring and countersink holes of alloy and non-alloy aluminum sheet also coated steel, pipes, profiles and Plexiglas up to a thickness of 5 mm.
- Running three sharp fully rectified, provide machining with less vibration, a perfect finish, excellent chipping, and a speed 'high processing.
- Hexagonal 1/4 "for the immediate use of cordless drills or grafting of port bits
- To use it is recommended lubrication with our cutting oils cod. 411 00 01900 spray, 411 00 14860 liquid.

Code	Desc.	Ø svasat. mm	For screws TPS Ø	Length mm	Stem attachment
4430051600	1041/6,3	6,3	M3	31	1/4"
4430051610	1041/8,3	8,3	M4	31	1/4"
4430051620	1041/10,4	10,4	M5	34	1/4"
4430051630	1041/12,4	12,4	M6	35	1/4"
4430051640	1041/16,5	16,5	M8	40	1/4"
4430051650	1041/20,5	20,5	M10	41	1/4"

## Assortment countersink 90 ° three-sharp 1/4 "hexagonal



Code	Desc.	Tipo di svasatori din 335C-90°	Content
4430051660	1044	HSS WITH 1/4 "HEXAGONAL	6,3 - 8,3 - 10,4 - 12,4 - 16,5 - 20,5



## Diamond blades sectors for building



- Cutting discs with laser welded diamond segments, each indicated for use on various building materials such as granite, concrete, reinforced concrete.
- High cutting speed, high durability, low noise and vibration.
- Suitable for use in dry with angle grinders portable machines. Center hole fixing diameter 22.2 mm.
- Products certified for safety according to EN 13236.

Code	Desc.	Diam. mm	Vel. max giri/min.
417RC02190	131/115	115	80 M/S-13.300
417RC02195	131/125	125	80 M/S-12.200
417RC02200	131/230	230	80 M/S-6.600

## Dischi diamantati a corona continua turbo per edilizia



- Dischi diamantati turbo a corona continua sinterizzata, indicati per l'utilizzo sui vari materiali edili quali: graniti, cemento, cemento armato.
- Velocita' di taglio elevata, alta durata, massima silenziosita' ed assenza di vibrazioni.
- Indicati per l'utilizzo a secco con macchine smerigliatrici angolari portatili. Foro centrale di fissaggio diametro 22,2 mm.
- Prodotti certificati per la sicurezza secondo la norma EN 13236.

Code	Desc.	Diam. mm	Vel. max giri/min.
417RC02210	132/115	115	80 M/S-13.300
417RC02215	132/125	125	80 M/S-12.200
417RC02220	132/230	230	80 M/S-6.600

## Disco diamantato fascia continua per taglio gres e ceramiche



- Disco diamantato con tagliente liscio a corona continua sinterizzato, indicato per il taglio specifico di ceramiche, klinker, gres porcellanato. Non indicato per marmo.
- Velocita' di taglio elevata, estrema pulizia di taglio, alta durata, massima silenziosita' ed assenza di vibrazioni.
- Indicati per l'utilizzo a secco con macchine smerigliatrici angolari portatili. Foro centrale di diametro 22,2 mm.
- Prodotto certificato per la sicurezza secondo la norma EN 13236.

Code	Desc.	Diam. mm	Vel. max giri/min.
417RC02230	133/115	115	80 M/S-13.300

## Corone per il carotaggio a umido

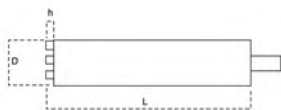

- Corone diamantate per il carotaggio a umido.
- Ideali per forare nel calcestruzzo e nel cemento armato.
- **Settore di utilizzo:** impiantistica, termoidraulica, elettricisti.
- Per creare diversi tipi di fori, tra cui per: la ventilazione, il passaggio di cavi elettrici, le canaline passacavo, le tubazioni idrauliche, l'installazione condizionatori e riscaldamento.
- **Vantaggi:** assenza di polvere durante la foratura, durata maggiore della corona diamantata grazie al continuo flusso d'acqua.
- Segmenti diamantati che aumentano la velocità di taglio.
- Attacco filettato 1 1/4".

4

Code	Desc.	Ø D mm	Useful length (L) mm	Segment height (h) mm	Attachment
417RC10650	248/42	42	420	7,5	1 1/4" UNC
417RC10660	248/52	52	420	7,5	1 1/4" UNC
417RC10670	248/57	57	420	7,5	1 1/4" UNC
417RC10680	248/62	62	420	7,5	1 1/4" UNC
417RC10690	248/72	72	420	7,5	1 1/4" UNC
417RC10700	248/82	82	420	7,5	1 1/4" UNC
417RC10710	248/102	102	420	7,5	1 1/4" UNC
417RC10720	248/112	112	420	7,5	1 1/4" UNC
417RC10730	248/122	122	420	7,5	1 1/4" UNC
417RC10740	248/127	127	420	7,5	1 1/4" UNC
417RC10750	248/132	132	420	7,5	1 1/4" UNC
417RC10760	248/152	152	420	7,5	1 1/4" UNC
417RC10770	248/162	162	420	7,5	1 1/4" UNC
417RC10780	248/182	182	420	7,5	1 1/4" UNC
417RC10790	248/202	202	420	7,5	1 1/4" UNC
417RC10800	248/232	232	420	7,5	1 1/4" UNC

## Continuous rim diamond blade for abrasive materials



- Special diamond disc with continuous rim segments, specific masonry saws and abrasive such as cement, concrete, tiles, abrasives, refractories, porphyry, natural stones.
- Very high efficiency and long life even in presence of very high abrasiveness of the material being cut.
- High cutting speed, high durability, low noise, and vibration.
- Suitable for use in dry machines portable angle grinders. Central hole of 22.2 mm.
- Product certified according to EN 13236 safety.

Code	Desc.	Diam. mm	Vel. max giri/min.
417RC02240	134/230	230	80 M/S-6.600

## Diamond blades for cutting asphalt



- Diamond disks for cutting asphalt, indicated for cutting asphalt cements and concretes in gender.
- Products that for asphalters, builders and construction in general.
- The diamond discs Meccanocar are composed of sectors laser welded to ensure greater resistance and to avoid the detachment of the sector itself.
- Discs consist of 21 sectors of 40 mm and a height of 3.6 mm.
- Used by machines with maximum power 20 HP.

Code	Desc.	Disc diameter mm	Internal hole diameter mm
417RC04600	175/A	350	30
417RC04800	176/A	400	30
417RC05000	177/1	-	Reduction from 30 to 25.4

## Diamond blades for cutting concrete



- Dischi diamantati per taglio cemento armato. Indicati per taglio cemento, cemento armato, granito, marmo, mattoni pieni e materiali simili.
- Prodotti particolarmente indicati per movimento terra, imprese edili ed asphaltisti.
- I dischi diamantati meccanocar sono composti da settori saldati a laser per garantire maggiore resistenza ed evitare il distacco del settore stesso.
- Dischi composti da 21 settori di 40 mm e altezza 3,6mm.
- Da utilizzare con macchine con potenza massima 20HP.

Code	Desc.	Disc diameter mm	Internal hole diameter mm
417RC04700	175/C	350	30
417RC04900	176/C	400	30
417RC05000	177/1	-	Reduction from 30 to 25.4
417RC05100	177/2	-	Reduction from 30 to 22.2

## Diamond blades for grooving



- Dischi speciali da taglio con segmenti diamantati saldati al laser, specifici per l'utilizzo su macchine scanalatrici, su materiali edili quali: mattoni, forati, cemento, laterizi.
- Velocita' di taglio elevata, alta durata, massima silenziosita' ed assenza di vibrazioni.
- Indicati e forniti nelle misure e con i fori centrali adatti alla maggior parte delle macchine scanalatrici in commercio.
- Prodotti certificati secondo la normativa di sicurezza EN 13236.

Code	Desc.	Diam. mm	Foro centr. mm
417RC02250	135/150	150	22,2
417RC02260	135/180	180	22,2
417RC02270	135B/150	150	30 + 4 HOLES
417RC02245	135/125	125	22,2

## Cutter anti-shock



- Metal body with protections in ABS.
- Vessel with three blades incorporated.
- With broken blade.

Code	Desc.
4430027598	342/9

Spare Parts			
Article	Code	Description	H blade mm
REPLACEMENT BLADES	4430027601	342/1	9

4

## Cutter anti-shock



Rotella per blocco lama

- Metal body with protections in ABS.
- Tank with 5 blades embedded.
- With broken blade.

Code	Desc.
4430045478	588/18

Spare Parts			
Article	Code	Description	H blade mm
REPLACEMENT BLADES	4430045481	588/1	18

## Cutter professional aluminum



- Slip grip cast aluminum coated in rubber.
- Stainless steel body.
- Autoloader for 6 blades (42 cutting features without recharging).
- Comes with 5 blades.
- Additional screw for the locking device for the blade.

Code	Desc.	H blade mm
4430049265	909	18

Spare Parts			
Article	Code	Description	H blade mm
LAME RICAMBIO	4430045481	588/1	18



## Cutter extra long



- Cutter Professional extra long, size 280 x 40 x 20 mm. Useful to carry out work in otherwise unreachable points.
- Used successfully in all fields of work, is indispensable in vehicle when replacing the crystals glued, lets get to cut the old caulk in places where you can not 'access to other tools or cutting wires.
- It comes with a blade.

Code	Description
4430055815	1520 Cutter Extra-long
4430045481	588/1-Replacement blades h. 19 mm

## Cutter accident prevention



- Cutter retractable blade, the blade at rest remains completely within the body and must be the operator to operate the knob pops out. The blade that is connected to the internal device using a spring, falls automatically as soon as the operator lifts the finger from the knob.
- With recess which he leaves uncovered a portion of the blade that can be employed without any risk of the operator for cutting wires or synthetic strapping.
- The body of the cutter may contain 5 spare blades. Supplied with 1 blade cutter.
- The cutter accident prevention is recommended for all those who use this type of tool without risk of cutting too deep.

Code	Description	Replacement blades
4430056530	1764	4770002386-238T

## Cutter with a blade 25mm



- Cutter for cutting of materials also thick as compressed cardboard and strapping polyethylene.
- The blade thickness from 0,7mm confers a high resistance to breakage.
- Tool suitable for warehouse workers and receptionists goods.
- Supplied with a blade.
- With cutter wheel for locking the opening / closing of the blade and with a small magnet in the back for use as a magnet for picking up small metal objects.

Code	Description
4430056540	1765

Spare Parts			
Article	Code	Description	H blade mm
REPLACEMENT BLADES	4430056550	1765L-Series 10 pc	25



## Jack knife



- Knife with blade in opaque stainless steel.
- Aluminium handle with clip on the rear.
- Equipped with a blocking mechanism.
- Practical and easy to use tool. Useful for all work activities.

Code	Description	L1 mm	L2 mm
4430058000	1778-Jack knife	112	188

## Cutting Kit



- Carrying case containing:
  - 1 cutter with metal body.
  - 1 straight handle port blades and blades of various shapes (for type 5) for various types of work.
- With the straight handle it is possible, thanks to the blades of different shapes perform the work of cutting and scraping.
- Ideal for cutting jobs of rubber profiles, seals, paper and cardboard, strapping etc.

Code	Desc.	Type
4770002380	238	CUTTING KIT

Spare Parts		
Article	Code	Description
LAMA RICAMBIO 12mm Conf. 10pz	4770002382	238 - 12
LAMA RICAMBIO 16mm Conf. 10pz	4770002383	238 - 16
LAMA RICAMBIO 20mm Conf. 10pz	4770002384	238 - 20
LAMA RICAMBIO 16mm-53° Conf. 10pz	4770002385	238 - 16-35°
TAGLIERINA Conf. 10pz	4770002386	238 - T
IMPUGNATURA DRITTA	4770002388	238 - IMP
CUTTER	4770002389	238 - C

## Scissors for electricians straight type



- Special steel blade with serrated.
- Burnished blade.
- Anatomic grip, handle made of cellulose acetate.

Code	Desc.	L. tot.
4430002600	189	140 mm

## Scissors for electricians type folded



- Special steel nickel.
- Anatomic grip, handle made of cellulose acetate.

Code	Desc.	L. tot.
4430002610	189P	140 mm

## Electrician scissors



- 440 stainless steel blades.
- Blade hardness 52 / 54HRC.
- With micordentatura and cutter.
- Handles two-component increased section.
- With nut adjustable.

Code	Desc.	L. tot.
4430002604	189B	145 mm

## Electrician scissors



- Straight blade.
- Stainless steel blades ultra light.
- With micro-toothing for precise cuts and particularly difficult.
- Handles in ABS with oversized rings for better grip.

Code	Desc.	L. tot.
4430002602	189A	145 mm

## Electrician's scissors, straight cut



- Scissor professional electrician, allows fast, clean cuts.
- AISI 420 stainless steel blade HRC 56, with double heat treatment to give it greater hardness. Finely serrated blade slip.
- Nylon handles reinforced with fiberglass. The handholds allestemit of the eyelets, allow the user to make more pressure with the finger during cutting.
- With adjustable screw and nut.

Code	Desc.	L. tot.
4430002611	189KA	145 mm

## Multipurpose shears



- Straight blade stainless steel of considerable thickness.
- Serrated.
- Polypropylene handles.
- Especially recommended for its robustness and manageability in all areas for cutting paper-cardboard-strapping-wire-cables in steel-etc.

Code	Desc.	L. tot.
4430002606	189C	190 mm

## Multipurpose scissors



- Professional.
- Stainless steel blade.
- Coated handles.
- For cutting paper, cardboard, carpet and fabric.
- With adjustment nut x.
- Blade length 90 mm.
- High cutting capacity.

Code	Desc.	L. tot.
4430027510	342CV	220 mm

## Die-cutting pliers



- Drilling of gaskets, paper, cardboard, leather.
- Body in chromed steel.
- Equipped with 6 punches.

Code	Desc.	Ø mm
4430016800	264	2-2,5-3-3,5-4-4,5

## Manual deburring

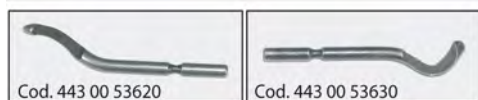

- Hand tool ideal for all those deburring and finishing of holes and edges.
- Field of use: carpentry, joinery, electrical and thermo-sanitary maintenance.
- For materials: plastic pipes, steel, copper; steel sheets, aluminum, copper, and plates made of plastic material.
- Features: possibility of drill holes both inside and outside.
- The mobility of the blade allows it to fit on each of the edges.
- Blades made of special steel with a high content of carbon, and heat treated to improve the cutting edge.
- Lightweight and practical.
- Solid ergonomic plastic, resistant to shocks and falls.
- With inner rod telescopic, for deburring holes and particular difficult to reach.
- Internal reservoir for spare blades. Reamer supplied without blades.

Code	Desc.	Utilization
4430053610	1072	Deburring with telescopic
4430053620	1073/1	HSS blade for steel, aluminum and plastic
4430053630	1073/2	HSS blade, for smudging int / east to 4 mm

## Scraper at knife



- With interchangeable blade.

Code	Description
4430045285	559 SCRAPER
4430045295	561 SERIES 10 BLADES

## Scraper at knife



- Long handle.
- Interchangeable.
- Ideal to remove glue, labels and stickers from the windows.

Code	Description
4430045290	560 SCRAPER
4430045295	561 SERIES 10 BLADES

## Scraper by spatula



- Large work surface.
- Ideal for removing residues of seals from windows and profiles.

Code	Desc.
4430045300	562

4

## Cut and trim silicones and sealants



- Simple and essential tool that allows you to cut and easily delete all adhesives, silicones and sealants of all kinds, dried, by so fast corners and without any residue.
- Indispensable in Replacement Glass operations on frames of all kinds, wood, PVC or metal, also excellent in removing old sealants body repair, transformation of vehicles in factories, construction and repair of motor homes and caravans.
- Article built in special polymer "POM", resistant and wear-resistant, sharp and durable cutting edges, the back of a spatula and serrated for the removal of final residues.
- It allows the perfect cleaning of the joints, removing all traces of old sealant mechanically, allowing removal of glazing or panels to be replaced cleanly and promptly without scratching the paint or sensitive surfaces. It is used with a single hand in a simple manner.
- Dimensions: 212 X 34 X 25.5 mm. Weight 40 grams.

Code	Desc.
4770006540	741



## Cutting discs thin Meccanocar



- Dischi abrasivi da taglio linea Meccanocar, studiati appositamente per applicazioni industriali con grandi consumi e prezzi di acquisto competitivi. Buone prestazioni e durata, gamma completissima di diametri e spessori.
- Indicati per utilizzi in medie e grandi industrie, cantieri, officine mobili. Ottimi per l'utilizzo da parte di carpenterie metalliche, montatori, manutentori, ecc.
- Costruiti con materiali vergini di prima scelta, rispondenti alle normative di sicurezza europee EN 12413 ed OSA.
- Disponibili in esecuzione piana, per materiali ferrosi ed acciaio inox, con diversi spessori nei vari diametri, a seconda delle esigenze degli utilizzatori.

Code	Descr. Ø x thickness	Ø foro	Vel. max giri/min.	Center	For materials
3400100100	115X1,0/M	22,2	13.300	plan	iron
3400100200	115X3,2/M	22,2	13.300	plan	iron
3400100300	125X1,0/M	22,2	12.250	plan	iron
3400100400	125X1,6/M	22,2	12.200	plan	iron
3400100500	125X3,2/M	22,2	12.200	plan	iron
3400100800	230X2,0/M	22,2	6.650	plan	iron
3400100900	230X2,5/M	22,2	6.650	plan	iron
3400101000	230X3,2/M	22,2	6.650	plan	iron
3400200100	115X1,0/T	22,2	13.300	plan	stainless steel
3400200200	115X1,6/T	22,2	13.300	plan	stainless steel
3400200300	125X1,0/T	22,2	12.200	plan	stainless steel
3400200400	125X1,6/T	22,2	12.200	plan	stainless steel

## Grinding wheels Grinding Specialist



- Abrasive wheels for grinding resin reinforced with portable machines, universal use on ferrous metals and steel.
- Suitable for sanding on rolling, quick removal of weld seams, deburring of mergers and cuts of tubular and solid materials, grinding of metal.
- Used in the fields: metal, electrical, thermo-sanitary, maintenance, wood, building, body shops, mechanics.
- Abrasion high speed, average duration, optimum resistance to stress.
- Corresponds to EN 12413, according to the indications of the institution building OSA.

Code	Descr. Ø x thickness	Ø foro centrale mm	Center	Revolutions min. max	For materials
3410001400	75 X 6,4 mm	10	Plan	20.200	Iron-Steel
3410000075	100 X 6,4 mm	16	Depressed	15.300	Iron-Steel
3410000110	115 X 6,4 mm	22,2	Depressed	13.300	Iron-Steel
3410000400	115 X 6,4/A mm	22,2	Depressed	13.300	Aluminum-Light alloys
3410000130	125 X 6,4 mm	22,2	Depressed	12.200	Iron-Steel
3410000150	150 X 6,4 mm	22,2	Depressed	10.200	Iron-Steel
3410000210	180 X 6,4 mm	22,2	Depressed	8.500	Iron-Steel
3410000300	230 X 7 mm	22,2	Depressed	6.600	Iron-Steel

## Grinding wheels Grinding Specialist Conical

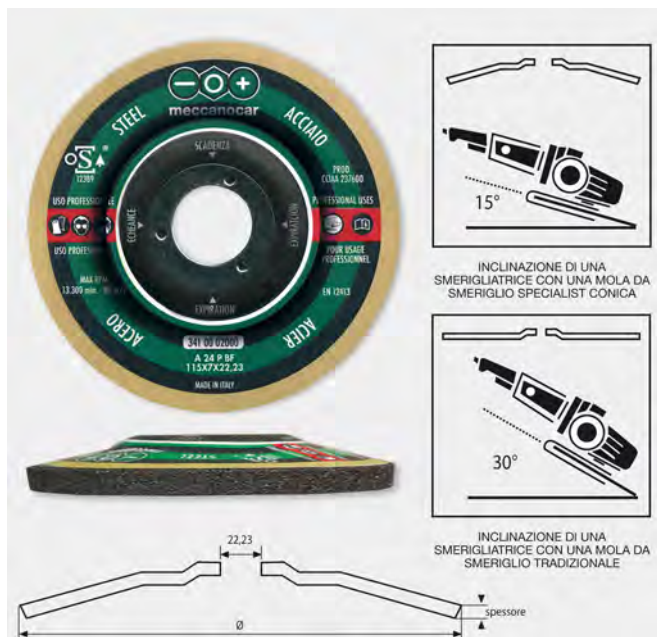

- Abrasive discs stronger bevel grinding.
- To be used on iron and steel. suitable for sanding of sheet metal, removal of weld seams, deburring melting, burrs cutting and grinding of metal.
- Used in the following sectors: light and heavy carpentry, window, plant engineering, construction, mechanical and bodywork.
- Ideal for working on large flat surfaces and angular.
- The conical shape allows to increase the contact surface between the material and the disc, providing a removal greater and faster compared to a grinding wheel Grinding traditional. In addition, it allows the operator to maintain the grinder less inclined during use, improving working comfort.
- Compliant with European standards EN 12413 and OSA.

Code	Descr. Ø x thickness	Ø foro centrale mm	Center	Revolutions min. max
3410002000	115X7/C mm	22,23	depressed	13300
3410002010	125x7/C mm	22,23	depressed	12250
3410002020	230x7/C mm	22,23	depressed	6650

## Cutting discs to thin Meccanocar "Specialist"



- Dischi abrasivi da taglio serie Meccanocar "Specialist", dalle prestazioni superiori per utilizzatori professionali, dall'ottimo rapporto qualità prezzo, per lavorazioni gravose nel settore della carpenteria metallica. Ottime capacità di taglio unite a lunga durata dei dischi.
- Indicati per utilizzi nelle piccole industrie e da parte degli specialisti di settori quali artigiani fabbri e carpentieri, autocarrozzerie, trasformazioni di veicoli, cantieri navali.
- Costruiti con materiali vergini di prima scelta, rispondenti alle normative di sicurezza europee EN 12413 ed OSA.
- Disponibili in esecuzione piana e depresso, per materiali ferrosi, acciaio inox e leghe leggere, materiali edili con diversi spessori nei vari diametri, a seconda delle esigenze degli utilizzatori.



Code	Descr. Ø x thickness	Ø foro centrale mm	Center	Revolutions min. max	Type	Diameter mm
3400001000	75X1,2/F mm	10	Plan	20.200	Cutting iron	75 x foro centrale 10 mm
3400002600	75X3,2/F mm	22,2	Plan	13.300	Cutting iron	75 x foro centrale 10 mm
3400000020	115X3,2/F mm	22,2	Depressed	13.300	Cutting iron	115 x foro centrale 22,2 mm
3400000600	115X1,6/I mm	22,2	Plan	6.600	Cut stainless steel	115 x foro centrale 22,2 mm
3400001100	115X1,2/F mm	22,2	Plan	13.300	Cutting iron	115 x foro centrale 22,2 mm
3400001500	115X1,6/A mm	22,2	Plan	13.300	Cutting aluminum	115 x foro centrale 22,2 mm
3400002400	115X0,8/FI mm	22,2	Depressed	12.200	Cutting	115 x foro centrale 22,2 mm
3400000030	125X1,6/I mm	22,2	Depressed	12.200	Cutting iron	125 x foro centrale 22,2 mm
3400000700	125 X 1,6/A mm	22,2	Plan	12.200	Cut stainless steel	125 x foro centrale 22,2 mm
3400001200	125X1,6/F mm	22,2	Plan	12.200	Cutting iron	125 x foro centrale 22,2 mm
3400001600	125X1,6/A mm	22,2	Plan	12.200	Cutting aluminum	125 x foro centrale 22,2 mm
3400002500	125X0,8/FI mm	22,2	Depresso	12.200	Cutting iron - stainless steel	125 x foro centrale 22,2 mm
3400000040	150X3,2/F mm	22,2	Depressed	10.200	Cutting iron	150 x foro centrale 22,2 mm
3400000060	180X1,6 mm	22,2	Plan	8.500	Cut stainless steel	180 x foro centrale 22,2 mm
3400000105	230X2,5 mm	22,2	Depressed	6.650	Cutting iron	230 x foro centrale 22,2 mm
3400000110	230X3,2 mm	22,2	Depressed	6.650	Cutting iron	230 x foro centrale 22,2 mm
3400000500	230X3,2/C mm	22,2	Depressed	6.650	Friable materials	230 x foro centrale 22,2 mm
3400001400	230X2,0/F mm	22,2	Plan	6.650	Cutting iron	230 x foro centrale 22,2 mm

## Cutting discs Meccanocar "Top Specialist"



- Thin cutting discs for professional work with portable machines.
- For use on iron, steel, stainless and alloy steels, to make precise cuts and fast on round, sheets, nets, pipes, profiles, bars.
- Used in the following sectors: light and heavy carpentry, window, plant engineering, construction, mechanical and bodywork.
- Thanks to its special profile, helical, the friction in the cutting step is significantly reduced, thus avoiding the overheating of the disk.
- Compared to a traditional disk, the grinding wheel Top Specialist provides the operator with better performance in durability, and cutting precision. They are also reduced the formation of burrs.
- Furthermore, the particular compound and abrasive reinforcement fabrics, increase its its toughness even in the more severe operation.
- Compliant with European standards EN 12413 and OSA.

Code	Descr. Ø x thickness	Ø foro centrale mm	Center	Revolutions min. max	For materials
3400003000	115x1/T mm	22,2	Plan	13.300	Cutting iron-Stainless Steel
3400003010	115x1,6/T mm	22,2	Plan	13.300	Cutting iron-Stainless Steel
3400003020	125x1/T mm	22,2	Plan	12.200	Cutting iron-Stainless Steel
3400003030	125x1,6/T mm	22,2	Plan	12.200	Cutting iron-Stainless Steel
3400003040	230x1,9/T mm	22,2	Plan	6.650	Cutting iron-Stainless Steel

## Cutting discs and emery Meccanocar "Top Specialist 3 in 1"



- Dischi speciali studiati per operazioni di taglio, sbavo e molatura con un unico utensile. La particolare conformazione e costruzione del disco permette di: ottenere tagli netti e precisi con bassa formazione di bave, sbavare immediatamente e molare anche di piatto per togliere cordoni di saldatura ed altre imperfezioni.
- Indicati per tutte le operazioni nelle lavorazioni di ferro, acciaio ed anche acciaio inox, in tutti i settori lavorativi.
- Mescola abrasiva a base di zirconio, priva di ferro, impedisce la formazione di ossido e ruggine, distorsioni e colorazioni anche quando sono usati su leghe leggere ed acciai inox. Tele di rinforzo resistentissime e a prova di qualsiasi sollecitazione.

Code	Descr. Ø x thickness	Ø foro centrale mm	Center	Revolutions min. max	For materials
3400003070	115x2,2/T	22,2	Depressed	13.300	Iron-Stainless steel
3400003080	125x2,2/T	22,2	Depressed	13.200	Iron-Stainless steel



## Mole da taglio per macchine fisse



- Grinding wheels in resin reinforced corundum cutting.
- For use on stationary machines with mechanical clamping.
- For cutting of profiles, tubes, bars, sheets, normal steels, cast iron, ferrous and nonferrous.
- Professional handling for heavy machining.

Code	Descr. Ø x thickness	Ø foro	Velocità max RPM/min.
3400000300	300X4	30	5100



## Cutting discs for portable machines and stationary



- Mole flat abrasive resin reinforced with corundum.
- Suitable for use on stationary machines with power less than 3 HP, and on portable machines with a power below 4 HP.
- For profile cutting, thin-walled, cutting of rods, tubes, stainless steel, ferrous and non.
- Professional handling for heavy machining.

Code	Descr. Ø x thickness	Ø foro	Velocità max RPM/min.
3400000800	300X2,8	25,4	5100
3400000900	350X3	25,4	4300



## Vitrified grinding wheels for iron and steel normal



- Resin grinding wheel for grinding and grinding with stationary machines.
- Construction corundum gray 96%, 60 grit.
- Color: Grey.

Code	Desc.	Ø mm	Thickness mm	Hole diam. mm
4430042895	478-150X16	150	16	16
4430042896	478-150X20	150	20	16
4430042900	478-200X25	200	25	20
4430042902	478-250X25	250	25	25

## Vitrified grinding wheels for HSS



- Resin grinding wheel for grinding and grinding with stationary machines.
- Construction rose 99% corundum, grain 60.
- Pink color.

Code	Desc.	Ø mm	Thickness mm	Hole diam. mm
4430050705	1013-150X20	150	20	16
4430050710	1013-200X25	200	25	20
4430050715	1013-250X25	250	25	25



### Vitrified grinding wheels for carbide (Hartmetall)



- Resin grinding wheel for grinding and grinding with stationary machines.
- Construction silicon carbide, 80 grit.
- Green Colour.

Code	Desc.	Ø mm	Thickness mm	Hole diam. mm
4430050725	1014-150X20	150	20	16
4430050730	1014-200X25	200	25	20
4430050735	1014-250X25	250	25	25

### Stone wheel dressers



- Rectangular stone silicon carbide for sharpening resinoid wheels vitrified.
- Dimensions: 200x50x25 mm.

Code	Desc.
4430050740	1015

### Stalk diameter 6mm for grindstone with 10 mm hole



- Steel pin 6mm diameter x 18mm in length, with thread m10 for mounting and the use of all the discs with a central hole of 10 mm.
- The pin of 6 mm diameter allows the use of each type of drill, cordless screwdriver, straight grinder, etc.
- Maximum thickness of 25 mm can be clamped.

Code	Desc.
4940001740	130 P

## Grinder corundum pink pin



Code	Desc. Ø x L	Type
4430041190	462 - 12x20	Cylindrical Type "A"
4430041205	462 - 15x15	Cylindrical Type "A"
4430041230	462 - 20x30	Cylindrical Type "A"
4430041250	462 - 25x15	Cylindrical Type "A"
4430041535	464 - 15x25	Cylindrical - Conical Type "C"
4430041540	464 - 20x30	Cylindrical - Conical Type "C"
4430041550	464 - 25x40	Cylindrical - Conical Type "C"
4430041725	466 - 15	Dhaped ball Type "E"
4430041735	466 - 25	Dhaped ball Type "E"
4430041740	467 - 20x25	Conical Type "F"
4430041742	467 - 30x30	Conical Type "F"
4430042425	473 - 20x30	Trunk-Conical Type "N"

- Shank  $\varnothing$  6 mm
- Corundum of high quality for grinding and deburring
- For normal steels, alloy steels, cast irons and non-ferrous metals

## Wheel series of pin pink corundum



- Nr. 5 assorted soft shank diameter 6 mm.

Code	Desc.
4430040860	39900

## Lamellar grinding disks corundum



Code	Descr. Gr x Ø	Foro Ø	Velocità 1 min. RPM	Type
3370000050	36 x 115	22.2	13.300	NYLON SUPPORT
3370000100	40 x 115	22.2	13.300	NYLON SUPPORT
3370000200	60 x 115	22.2	13.300	NYLON SUPPORT
3370000300	80 x 115	22.2	13.300	NYLON SUPPORT
3370000400	120 x 115	22.2	13.300	NYLON SUPPORT
3370001900	40 x 125	22.2	12.200	NYLON SUPPORT
3370002000	60 x 125	22.2	12.200	NYLON SUPPORT
3370002100	80 x 125	22.2	12.200	NYLON SUPPORT
3370002200	120 x 125	22.2	12.200	NYLON SUPPORT
3370001600	40 x 180	22.2	8.600	NYLON SUPPORT
3370001700	60 x 180	22.2	8.600	NYLON SUPPORT
3370000750	36 x 115	22.2	13.300	FIBER SUPPORT
3370000800	40 x 115	22.2	13.300	FIBER SUPPORT
3370000900	60 x 115	22.2	13.300	FIBER SUPPORT
3370001000	80 x 115	22.2	13.300	FIBER SUPPORT
3370001100	120 x 115	22.2	13.300	FIBER SUPPORT
3370002300	40 x 125	22.2	12.200	FIBER SUPPORT
3370002400	60 x 125	22.2	12.200	FIBER SUPPORT
3370002500	80 x 125	22.2	12.200	FIBER SUPPORT
3370002600	120 x 125	22.2	12.200	FIBER SUPPORT

- Flap discs with twin wire resin corundum.
- Support nylon or glass fiber.
- Suitable for alloy steel, normal, non-ferrous metals, light alloys.
- Available in different grit sizes and diameters, all usable without the need for backing pads reinforcement.

## Lamellar grinding disks zirconium



Code	Descr. Gr x Ø	Foro Ø	Velocità 1 min. RPM	Type
3370100050	40 x 115	22.2	13.300	NYLON SUPPORT
3370100070	60 x 115	22.2	13.300	NYLON SUPPORT
3370100080	80 x 115	22.2	13.300	NYLON SUPPORT
3370100200	40 x 125	22.2	12.200	NYLON SUPPORT
3370100210	60 x 125	22.2	12.200	NYLON SUPPORT
3370100220	80 x 125	22.2	12.200	NYLON SUPPORT
3370100170	40 x 180	22.2	8.600	NYLON SUPPORT
3370100180	60 x 180	22.2	8.600	NYLON SUPPORT
3370100190	80 x 180	22.2	8.600	NYLON SUPPORT
3370100120	40 x 115	22.2	13.300	FIBER SUPPORT
3370100130	60 x 115	22.2	13.300	FIBER SUPPORT
3370100140	80 x 115	22.2	13.300	FIBER SUPPORT
3370100230	40 x 125	22.2	12.200	FIBER SUPPORT
3370100240	60 x 125	22.2	12.200	FIBER SUPPORT
3370100250	80 x 125	22.2	12.200	FIBER SUPPORT
3370100145	40 x 180	22.2	8.600	FIBER SUPPORT
3370100150	60 x 180	22.2	8.600	FIBER SUPPORT
3370100160	80 x 180	22.2	8.600	FIBER SUPPORT

- Lamellar disks with twin-wire zirconia, support nylon or glass fiber.
- Suitable for high-strength metals, stainless steel, cast iron, aluminum.
- Available in various grits and sizes.
- ATTENTION: for use of the diameter 165 mm. and 'it recommended to use the special pad cod. 337 00 01200-1650.
- diameter discs 115, 125 and 180 mm. They do not require sanding pad reinforcement.

## Lamellar zirconium disks conical

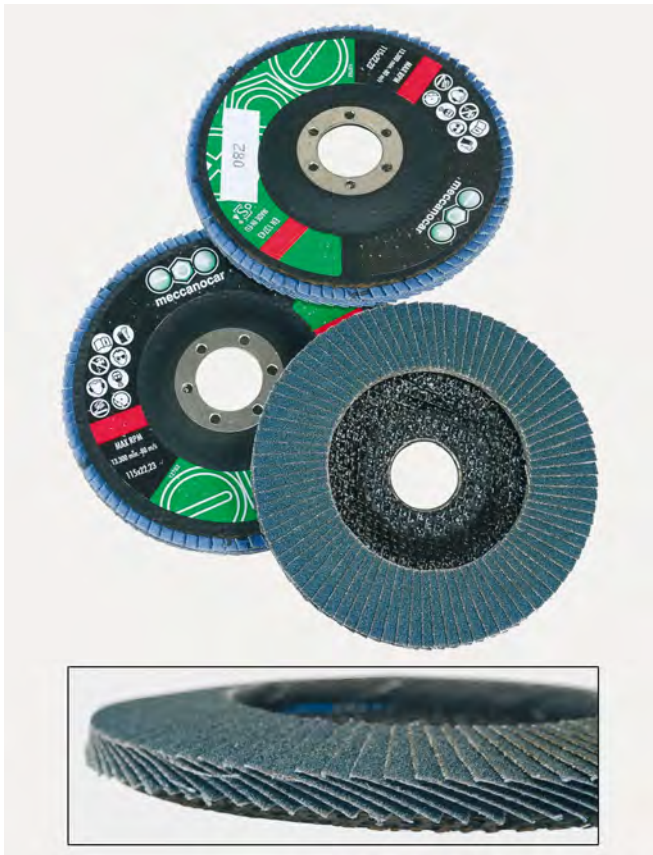

- Lamellar grinding disks in zirconium canvas , support glass fiber and conical shape of the slats.
- Ideal for roughing and finishing of metals of all types, even hard steels and steel.
- Product indicated for use by locksmiths, carpenters, body shops, workshops of transformation, and in each workshop of metal processing.
- The conical shape allows to use the whole width of the slats also working with grinder tilted. The abrasive is supported completely by offering a removal more faster, and longer life of the disc. The fiber support is consumed by allowing you to fully exploit the abrasive side of the abrasive unilamellar arrangement allows the disc to exert maximum aggression 'and metal removal.

Code	Desc.	Grain	Ø mm	Velocita max RPM
3370100600	40X115CZ	40	115	13.300
3370100610	60X115CZ	60	115	13.300
3370100620	80X115CZ	80	115	13.300
3370100630	40X125CZ	40	125	12.200
3370100640	60X125CZ	60	125	12.200
3370100650	80X125CZ	80	125	12.200

## Lamellar disk zirconium high performance



- Lamellar disk zirconia with nylon support and glass fiber, high efficiency and durability.
- Product suitable for blacksmiths, carpenters and car bodies. For use on stainless steel, aluminum, cast iron.
- Construction to 110 lamellas. The higher concentration of abrasive in the points where the maximum pressure is exerted, cushions the contact on the machined surfaces making it more comfortable and effective work the operator.
- The product lasts considerably longer than a traditional disk, and the slats are completely consumed.

Code	Descr. Gr x Ø	Foro Ø	Velocità giri/min.	Type
3370100400	40X115 AN	22,2	13300	Nylon Support
3370100410	60X115 AN	22,2	13300	Nylon Support
3370100420	80X115 AN	22,2	13300	Nylon Support
3370100430	120X115 AN	22,2	13300	Nylon Support
3370100440	40X125 AN	22,2	12200	Nylon Support
3370100450	60X125 AN	22,2	12200	Nylon Support
3370100460	80X125 AN	22,2	12200	Nylon Support
3370100470	120X125 AN	22,2	12200	Nylon Support
3370100500	40X115 AF	22	13300	Fiber support
3370100510	60X115 AF	22	13300	Fiber support
3370100520	80X115 AF	22	13300	Fiber support
3370100530	120X115 AF	22	13300	Fiber support
3370100540	40X125 AF	22	12200	Fiber support
3370100550	60X125 AF	22	12200	Fiber support
3370100560	80X125 AF	22	12200	Fiber support
3370100570	120X125 AF	22	12200	Fiber support

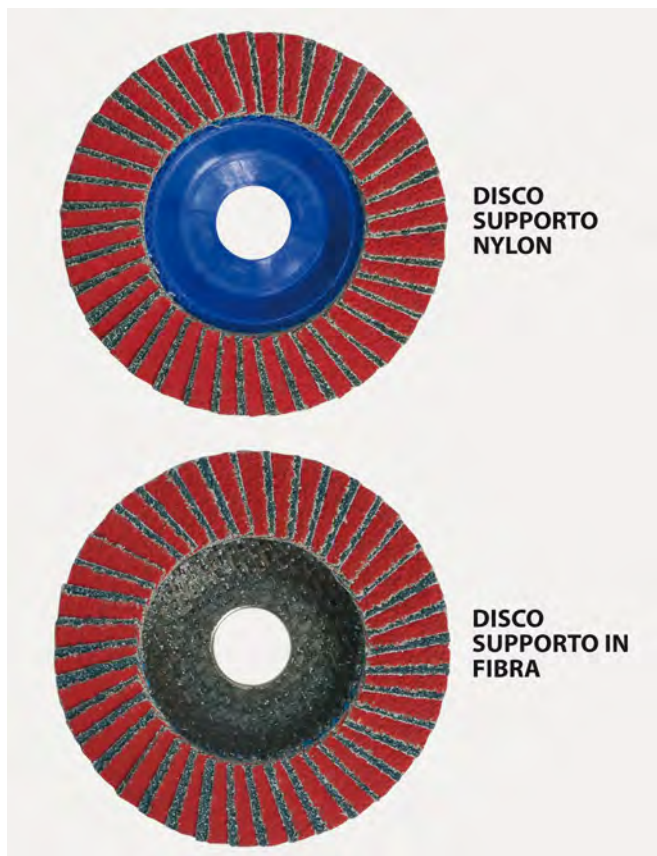

**Lamellar disk mixed ceramic and zirconium**

- Lamellar disk mixed ceramic and zirconium with support glass fiber and nylon.
- Highly professional product suitable for carpenters, blacksmiths and bodies. For use on stainless steel, mild steel, aluminum.
- The ceramic abrasive autoravvivandosi constantly during use, gives the disc a remarkable ability to cut ensuring greater speed of work, and lasts longer than any other lamellar disk.

Code	Descr. Gr x Ø	Foro Ø	Velocità giri/min.	Type
3370300010	40X115 CN	22,2	13300	Nylon support
3370300020	60X115 CN	22,2	13300	Nylon support
3370300030	80X115 CN	22,2	13300	Nylon support
3370300040	40X125 CN	22,2	12200	Nylon support
3370300050	60X125 CN	22,2	12200	Nylon support
3370300060	80X125 CN	22,2	12200	Nylon support
3370300100	40X115 CF	22,2	13300	Fiber support
3370300110	60X115 CF	22,2	13300	Fiber support
3370300120	80X115 CF	22,2	13300	Fiber support
3370300130	40X125 CF	22,2	12200	Fiber support
3370300140	60X125 CF	22,2	12200	Fiber support
3370300150	80X125 CF	22,2	12200	Fiber support

**Lamellar disks**

- Special Lamellar disks zirconium having a capacity of exceptional abrasive, built with top quality zirconium and cooling substances, able to quickly remove large amounts of material, even the hardest.
- Suitable for all machining grinding in any workshop, offers the best value for money and outstanding performance even on stainless steels and metals very hard. Especially sull'inox substances cooling prevents overheating of the workpiece and the resulting blue color.
- The backing pad is constructed with vegetable fibers, which assure the right flexibility, the reduction of the vibrations and the consumption without harmful emissions to use the disc to the end. The hard Viper HD removes up to 1 kg of stainless steel in 15-20 minutes. With a single disc are removed up to 4 kg of material.
- Available in grit sizes 40 and 60. For finishing we recommend the use of our records zirconium in the finer grits.

Code	Description Gr X Ø	Foro Ø	Velocità max giri/min	Velocità consigliata Giri/min.
3370100700	40X115	22,2	13200	6000-8000
3370100710	60X115	22,2	13200	6000-8000
3370100720	40X125	22,2	12200	6000-8000
3370100730	60X125	22,2	12200	6000-8000



## Lamellar disks "keramik"



- Dischi lamellari speciali con abrasivo ibrido-ceramico, dotati di una capacità abrasiva eccezionale, capaci di asportare velocemente materiali duri quali acciaio inox, titanio, bronzo, ecc. con una finitura superficiale eccezionale. Sgrosso e finitura in una sola operazione, per un risparmio enorme di tempo.
- Indicati per tutte le lavorazioni di smerigliatura in qualsiasi officina, permettono con una sola grana di avere la velocità di asportazione di una 40 ed ottenere subito il grado di finitura di una 60. Soprattutto sull'inox le sostanze raffreddanti evitano il surriscaldamento del pezzo lavorato e la conseguente colorazione blu.
- Il platorello di supporto è costruito con fibre vegetali, che assicurano la giusta flessibilità, la riduzione delle vibrazioni ed il consumo senza emissioni nocive per utilizzare il disco fino alla fine.
- Disponibili in unica grana. Per operazioni di finitura ulteriori si consiglia l'utilizzo dei nostri dischi allo zirconio nelle grane più fini.



Code	Description	Foro Ø	Velocità max giri/min	Velocità consigliata Giri/min.
3370100750	115/U	22,2	13200	5000-8000
3370100760	125/U	22,2	12000	5000-8000

## Lamellar disks for finishing "Sparks Flap"



- Lamellar disks in abrasive fabric soft and flexible, for the finishing of each metal surface. They allow the removal of rust, oxidation and surface irregularities. Allow sanding weld seams with TIG method, with a very fine finish and beautiful to behold.
- Conceived and designed especially for the machining of stainless steel in each field working, we are well suited also for other metals such as steel, brass, aluminum, bronze, copper, etc. Excellent for working in corners and narrow spaces, and for preparation for polishing or glazing.
- The recommended rate for maximum yield is between 4000 and 5000 rev / min, but it can easily withstand even the normal speed grinders without adjustments.
- The backing pad is constructed with vegetable fibers, which assure the right flexibility, the reduction of the vibrations and the consumption without harmful emissions to use the disc to the end.
- Available in different grits for different degrees of finish desired: coarse-grained (coarse), medium-grained (medium) and fine-grained (fine).

Code	Descr. Ø mm + Grain	Ø hole mm	Velocità max giri/min	Velocità consigliata Giri/min.
3420000560	SF 115 coarse	22,2	13200	4000-5000
3420000570	SF 115 medium	22,2	13200	4000-5000
3420000580	SF 115 fine	22,2	13200	4000-5000
3420000590	SF 125 coarse	22,2	12200	4000-5000
3420000600	SF 125 medium	22,2	12200	4000-5000
3420000610	SF 125 fine	22,2	12200	4000-5000

## Lamellar disks for stock removal and finishing "ONE"



- Lamellar disks abrasive fabric soft and flexible, with double action is both biting finish. They allow the removal of burrs and welding beads, rust, oxidation and surface irregularities with a finish very fine and beautiful to behold. Both in one operation.
- Conceived and designed especially for the machining of stainless steel in each field working, we are well suited also for other metals such as steel, brass, aluminum, bronze, copper, etc. Excellent for working in corners and narrow spaces, and for preparation for polishing or glazing.
- The recommended rate for maximum yield is between 4000 and 5000 rev / min, but it can easily withstand even the normal speed grinders without adjustments.
- The backing pad is constructed with vegetable fibers, which assure the right flexibility, vibration reduction, and consumption without harmful emissions to use the disc to the end.

Code	Desc. Ø mm	Ø hole mm	Velocità max giri/min	Velocità consigliata Giri/min.
3420000540	ONE 115	22,2	13200	4000-5000
3420000550	ONE 125	22,2	12200	4000-5000

## Mini lamellar disks 50 mm quick



- Mini lamellar disks of diameter 50 mm, with quick screw, zirconia abrasive for machining hard metals such as steel alloys, stainless steels and metals.
- Suitable for finish machining for all metalworking: body shops, transformation means, structural steel, blacksmiths, tinsmiths and all metalwork in general.
- Ideal for roughing, removing welding seams, remove burrs, finishing and cleaning surfaces.
- The quick coupling allows a fast and easy exchange of worn discs. are mounted on the supports with cylindrical shank 6 mm, our code 342 01 02000-64 / m1.
- Are preferably used on angle grinders, as our article code 418 00 07100 - 5695. or of any other tool with speed 'maximum rotation of 30,000 r / min.
- Comply with the law EN13743.

Code	Desc.	Grain	Vel. max giri/min.	Type
3370100350	40X50F	40	30000	Version with flexible slats
3370100360	60X50F	60	30000	VERSIONE CON LAMELLE FLESSIBILI
3370100370	80X50F	80	30000	VERSIONE CON LAMELLE FLESSIBILI

Spare Parts	
Code	Description
3420102005	64/M2 Discs d. - 51mm

## Abrasive diskettes quick connect

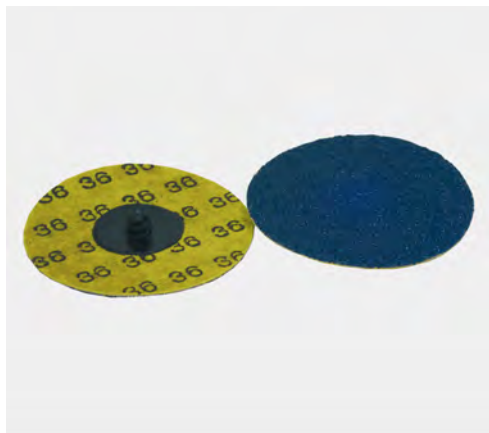

- Discs in abrasive cloth zirconia with quick screw. used with the appropriate pads with stem diameter 6 mm on straight grinders, angle and drills.
- Usable in all areas of metal working: auto body shops, trucks, mechanical, light carpentry, etc. for removal operations fast and finishing in small spaces of difficult access.
- The canvas zirconium ensures exceptional durability and performance of each material, including hard steels and steel.
- To be used in combination with special pads of the right diameter. Attack compatible 3M Roloc system.

Code	Desc.	Ø mm	Grain	Vel. max giri/min.
4940000450	36Z	51	36	25000
4940000460	60Z	51	60	25000
4940000470	80Z	51	80	25000
4940000480	120Z	51	120	25000
4940001700	36B	75	36	20000
4940001710	60B	75	60	20000
4940001720	80B	75	80	20000
4940001730	120B	75	120	20000

Spare Parts	
Code	Description
3420102005	64 / M2 Discs d. - 51mm
3420102010	64 / M4 Discs d. - 75mm

## Abrasive diskettes



- Abrasive diskettes wire diameter 50 and 75 mm with quick screw.
- Suitable for auto body shops and there, carpentry and window manufacturers.
- Present a particular plastic structure impregnated with abrasive making them suitable for the removal of rust, paint and varnishes, residues of adhesives, sealants, gaskets on all types of metal; particularly useful for pickling operations, deburring, finishing, for the removal of impurities' from natural stone, wood and plastic materials.
- Constructed of abrasive material for ceramic inner extreme resistance to high temperatures of friction.
- The particular shape them perfectly suited to the performance of the treated surfaces, even the most 'irregular, to an excellent finish and allows you to work even in hard to reach places.
- High performance abrasive thanks to the high speed 'of rotation reached (speed' recommended from 12000 to 18000 g / min).
- The compact structure in a single block ensures high resistance to detachment of the wires abrasive, guaranteeing greater safety to the operator.
- Reduction of working time thanks to the fast connection system, which allows easy and quick change of worn discs.
- To be used in combination with pads with quick screw our code 3420102005 to 3420102010 and mini sander angle ns. cod. 418 00 07100.

Code	Desc.	Color	Diam. mm	Grain
4930000005	50/60	VERDE	50	60
4930000010	50/80	GIALLO	50	80
4930000015	50/120	BIANCO	50	120

Spare Parts	
Code	Description
3420102005	64/M2 Discs d. - 51mm
3420102010	64/M2 Discs d. - 51mm



## Backing pads with quick screw



- Backing pads in plastic material with pin DA. 6 mm
- Usable with wheels and discs to quick screw.
- Compatible with the quick fastening system Roloc 3M.

Code	Desc.	For abrasive diameter	Photo
3420102000	64/M1	Wheels d.75mm Brushes D.50mm Discs d. - 25mm	1
3420102005	64/M2	Disks d. - 51mm	2
3420102010	64/M4	Disks d. - 75mm	3

## Fiber Abrasive disks



- Disk fast and aggressive corundum
- Excellent resistance to stress
- Strong abrasiveness'
- 22.2 mm center hole

Code	Desc. Gr x Ø
3390001000	24x115
3390001010	36x115
3390001020	60x115
3390001030	80x115
3390001040	100x115
3390001050	120x115
3390000400	24x125
3390000500	36x125
3390000510	60x125
3390000520	80x125
3390000530	100x125
3390000540	120x125
3390000100	16x180
3390000200	24x180
3390000300	36x180

## Accessories for fiber abrasive discs



- Plastic support plan.
- Flexibility 'high complete with lock nut with thread 14-MA 5/8 "W.

Code	Desc.	Ø disco	Ø supporto
3390001100	1150	115	110
3390001200	1250	125	120
3390001300	1800	180	165

## Abrasive wheels lamellar



- Wheels lamellae abrasive cloth resin corundum with 6mm diameter shank, for use on drills and die grinders.
- Indicate to carry out work on small areas or in hard to reach places.
- For machining of steel, stainless steel and non-ferrous metals.
- Available in different diameters and large

Code	Descr. Ø x Gr	Blades height	Velocità giri/min.
3370005000	30x60	15	22.900
3370005010	30x80	15	22.900
3370005020	30x120	15	22.900
3370005030	40x60	20	17.100
3370005040	40x80	20	17.100
3370005050	40x120	20	17.100
3370005055	60x40	30	11.400
3370005060	60x60	30	11.400
3370005070	60x80	30	11.400
3370005080	60x120	30	11.400
3370005090	80x60	30	8.500
3370005100	80x80	30	8.500
3370005110	80x120	30	8.500

## Sleeves spiral



- Sleeves abrasive cloth corundum for use on drills and sleeves spiral straight grinders.
- Suitable for machine shops, blacksmiths carpenters, finishing operations in general.
- To be mounted on our expanders ventilated with stem diameter 6mm.
- High capacity and speed of removal.
- Recommended applications: Finishing of molded parts, interior parts of cylinders, tubes, parts pierced and usually finishes in general.
- Application material: normal steel, non-ferrous metals and their alloys, plastics, plaster, wood, resins.

Code	Desc.	Diameter d mm	Height (H)	Grain
3370200010	10X80	10	10 mm	80
3370200020	10X120	10	10 mm	120
3370200030	22X50	22	20 mm	50
3370200040	22X80	22	20 mm	80
3370200050	22X120	22	20 mm	120
3370200060	30X50	30	30 mm	50
3370200070	30X80	30	30 mm	80
3370200080	30X120	30	30 mm	120
3370200090	45X50	45	30 mm	50
3370200100	45X80	45	30 mm	80
3370200110	45X120	45	30 mm	120

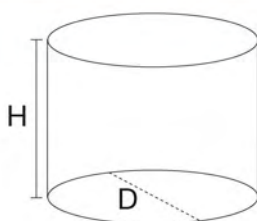



## Expanders ventilated

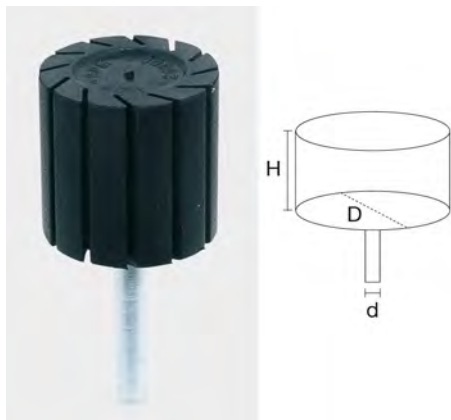

- Expanders ventilated pads, for the use of our sleeves spiral art. 337 02.
- Shank diameter 6mm.
- To be used mounted on drills or die grinders
- For all the finishing work.

Code	Desc.	Ø D mm	Height (H) mm	Ø d mm
3420102110	70/10	10	10 mm	6
3420102120	70/22	22	20 mm	6
3420102130	70/30	30	30 mm	6
3420102140	70/45	45	30 mm	6

## Sandpaper resin roll



Code	Desc.	Grain	Width mm	Length m	Tipo supporto
3460000100	40-H120x50	40	120	50	AW-D
3460000300	60-H120X50	60	120	50	AW-D
3460000400	80-H120X50	80	120	50	AW-D
3460000500	100-H120X100	100	120	100	AW-C
3460000600	120-H120X100	120	120	100	AW-C
3460000700	150-H120X100	150	120	100	AW-C
3460000800	180-H120X100	180	120	100	AW-C
3460000900	220-H120X100	220	120	100	AW-C
3460001000	240-H120X100	240	120	100	AW-C
3460001100	280-H120X100	280	120	100	AW-C
3460001200	320-H120X100	320	120	100	AW-C

- Sandpaper resin corundum
- Flexibility 'high
- Manual processing or machines with orbital
- Suitable for wood, paints and putties in body
- AW-D = corundum waterproof
- AW-C = corundum waterproof

## Sandpaper resin roll



- Sandpaper resin corundum
- For machining of wood, plastic and metal sheets
- A-F = rigid closed structure

Code	Desc.	Grain	Width mm	Length m	Tipo supporto
3440100100	40-H120x50	40	120	50	A-F
3440100300	60-H120X50	60	120	50	A-F
3440100400	80-H120X50	80	120	50	A-F
3440100500	100-H120X50	100	120	50	A-F
3440100600	120-H120X50	120	120	50	A-F
3440100700	150-H120X50	150	120	50	A-F
3440100800	180-H120X50	180	120	50	A-F

## Sandpaper resin sheets



- Sandpaper resin corundum
- Support "d"
- Open structure
- For use in dry and wet
- For processing machines with manual and orbital on wood, paints and plastics
- AW-D = corundum waterproof

Code	Desc.	Grain	Sheet Dimension mm	Typical paper
3430100010	40	40	230x280	AW-D
3430100020	50	50	230x280	AW-D
3430100030	60	60	230x280	AW-D
3430100040	80	80	230x280	AW-D
3430100050	100	100	230x280	AW-D
3430100060	120	120	230x280	AW-D

## Sandpaper sheets

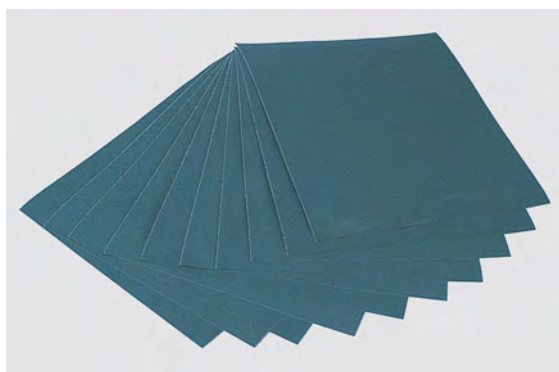

Code	Desc.	Grain	Sheet Dimension mm
3439700050	100	100	230x280
3439700100	150	150	230x280
3439700200	180	180	230x280
3439700300	220	220	230x280
3439700400	240	240	230x280
3439700500	280	280	230x280
3439700600	320	320	230x280
3439700800	400	400	230x280
3439700900	500	500	230x280
3439701000	600	600	230x280
3439701100	800	800	230x280
3439701200	1200	1200	230x280

- Sandpaper resin silicon carbide.
- Flexibility 'high, closed structure.
- Manual processing of varnished wood, plastics, enamels and fillers.
- Use dry and wet

## Abrasive canvas sheets

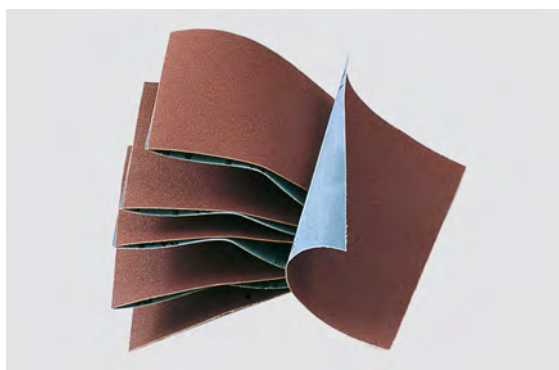

- Flexible cloth corundum, double resin
- For manual on steel, non-ferrous metals and leather
- DA-F = flexible corundum

Code	Desc.	Grain	Sheet Dimension mm	Tela tipo
3429600200	40	40	230x280	DA-F
3429600300	50	50	230x280	DA-F
3429600400	60	60	230x280	DA-F
3429600500	80	80	230x280	DA-F
3429600600	100	100	230x280	DA-F
3429600700	120	120	230x280	DA-F
3429600800	150	150	230x280	DA-F
3429600900	180	180	230x280	DA-F

## Abrasive canvas in rolls

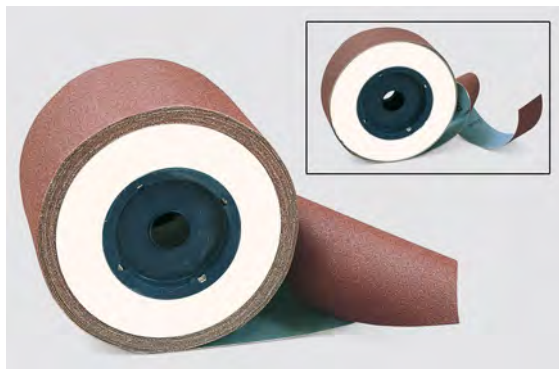

Code	Desc.	Grain	Width mm	Length m	Tela tipo
3440001300	40-H50x25	40	50	25	DA-F
3440001500	60-H50x25	60	50	25	DA-F
3440001600	80-H50x25	80	50	25	DA-F
3440001700	100-H50x25	100	50	25	DA-F
3440001800	120-H50x25	120	50	25	DA-F
3440001900	150-H50x25	150	50	25	DA-F
3440002000	180-H50x25	180	50	25	DA-F
3440000100	40-H120x25	40	120	25	DA-F
3440000300	60-H120x25	60	120	25	DA-F
3440000400	80-H120x25	80	120	25	DA-F
3440000500	100-H120x25	100	120	25	DA-F
3440000600	120-H120x25	120	120	25	DA-F
3440000700	150-H120x25	150	120	25	DA-F
3440000710	180-H120x25	180	120	25	DA-F

- Flexible canvas corundum double resin
- For manual on steel, non-ferrous metals and leather
- DA-F = flexible corundum

## Disco in tessuto abrasivo soffice



- Non graffia e non spolvera.
- Utilizzato per pulitura e finitura di superfici in genere.
- Viene utilizzato riunendo piu' dischi in modo da costruire una spazzola.
- Anche per mole da banco.
- Utilizzabile su platorello n/art. 339 00 01300-1800.

Code	Desc.	Grain	Ø mm	Ø hole mm	N° revolutions	Thickness mm
4940001000	200x20	FINE	200	20	3200	7

## Blocks flexible abrasive



- Blocks abrasive doughing flexible rubber, ideal for surface finishing by hand.
- Available in different grits, size 80x50x20mm.

Code	Desc.	Grain
3420000040	5/60	60
3420000050	5/120	120
3420000060	5/240	240

## Roller expansion machine polisher



- Roller expansion mounting abrasive tapes machines polishers, type our code 417 00 11400-ptx500.
- Suitable for mounting the abrasive tapes corundum, and zirconium.
- With its segments that expand, you get a better adaptation to the workpiece, cushioning the vibrations.
- With central hole 19 mm in diameter and housing for double key.

Code	Desc.	Measures (mm)
3420000300	16	Diam. 90x100

## Rollers abrasive corundum for polisher



- Roller corundum machine polishers, to be used with our roller expansion cod 00 342 00300-16
- Wide abrasive surface enables quick and effective action on many materials.
- For light deburring, cleaning, finishing small and large surfaces. removal of rust or marks left by previous operations.
- To be used with materials such as stainless steel, standard or alloyed steel, nonferrous metals and alloys, aluminum, cast iron, titanium, plastic, wood.

Code	Desc.	Measures diam./height mm	Vel. max giri/min.	Grain
3440110000	PTX50C	90x100	5700	50
3440110010	PTX80C	90x100	5700	80
3440110020	PTX120C	90x100	5700	120
3440110030	PTX150C	90x100	5700	150

## Zirconia abrasive rollers for polisher



- Roller zirconium machine polishers, to be used with our roller expansion cod 00 342 00300-16
- Excellent durability and high capacity 'removal.
- For sanding and cleaning of parts, deburring, removing small welding or projection welding and deep scratches.
- To be used with materials such as stainless steel, alloy steel.

Code	Desc.	Measures diam./height mm	Vel. max giri/min.	Grain
3440200600	PTX40Z	90x100	5700	40
3440200610	PTX50Z	90x100	5700	50
3440200620	PTX80Z	90x100	5700	80
3440200630	PTX120Z	90x100	5700	120



## Wheels lamellae polisher



- Wheels lamellae canvas corundum for working with machine polishers, type our code 417 00 11400-PTX500.
- With central hole 19 mm and accommodation for four taps.
- Long life and high gloss finish of the machined surfaces. Available in different grits.
- Application: for grinding and surface structuring, elimination of: even deep scratches, rust, oxidation, burrs and weld seams.
- Application materials: stainless steel, mild steel, alloy steel, aluminum, titanium, nonferrous materials and alloys, plastic, fiberglass, marble, stone.

Code	Desc.	Grain	Width mm	Ø mm	Foro centr. mm	Velocità giri/min.
3420000100	10/40	40	100	110	19	3800
3420000110	10/60	60	100	110	19	3800
3420000120	10/80	80	100	110	19	3800
3420000130	10/120	120	100	110	19	3800
3420000140	10/240	240	100	110	19	3800

## Wheels mixed canvas and non-woven fabric for polisher



- Wheels mixed construction in flexible canvas corundum interposed in nonwoven abrasive, for working with machine polishers, type our code 417 00 11400-PTX500.
- With central hole 19 mm and accommodation for four taps.
- Use: for dulling and finishing, remove minor scratches, surface defects, rust and oxidation.
- Application materials: stainless steel, steel or special, non-ferrous metals and their alloys, aluminum, cast iron and titanium.

Code	Desc.	Grain	Width mm	Ø mm	Foro centr. mm	Velocità giri/min.
3420000150	11/80	80	100	110	19	3800
3420000160	11/150	150	100	110	19	3800



## Wheels fleece for polisher



- Wheels construction Nonwoven Abrasive, working with machine polishers, type our code 417 00 11400-PTX500.
- With central hole 19 mm and accommodation for four taps.
- Use: for the structuring and for satin finishing small and large surfaces. removes oxidation. Great to smooth plastic surfaces.
- Application materials: stainless steel, steel or special, non-ferrous metals and their alloys, aluminum, cast iron, titanium and plastic.



Code	Desc.	Grain	Width mm	Ø mm	Foro centr. mm	Velocità giri/min.
3420000180	12/C	Grossa	100	110	19	3800
3420000190	12/M	average	100	110	19	3800
3420000200	12/F	Fine	100	110	19	3800
3420000210	12/VF	Super fine	100	110	19	3800

## Nylon wheels for burnishing



- Nylon wheels Abrasive, working with machine polishers, type our code 417 00 11400-PTX500.
- With central hole 19 mm and accommodation for four taps.
- Use: to remove rust, paint, oxidation, grease, oil and protective waxes. great to smooth plastic surfaces and wood.
- Application materials: stainless steel, steel or special, aluminum, titanium, nonferrous materials and alloys, fiber glass, plastic, fiberglass, wood and stone.

Code	Desc.	Width mm	Ø mm	Foro centr. mm	Velocità giri/min.
3420000250	13/N	100	100	19	4000

## Brass wire wheels for burnishing



- Wheels wire brush brass specifications for use on machines with polishers tree 19 mm, our article number 417 00 11400-PTX500.
- Suitable for processing in the areas of metal and wood. Allow the removal of rust, paint and burrs. Woodworking wheels allow obtaining effect "rustic".
- Housing shaft for two keys that makes it virtually universal, available in two widths of 25 and 70 mm, mountable through our kit spacers code 342 00 00400-32. 0.25 mm diameter wires.

Code	Desc.	Dimension Ø X Width mm
3420000420	32/25	100x25
3420000430	32/70	100x70

## Wheels Felt polisher



- Rollers felt hard, compact, made of merino compressed, diameter 100 mm, with central hole 19 mm and housing for four keys, for use with machine polishers type our code 417 00 11400-PTX500.
- Ideal for polishing processes with strong pressure on stainless steel, mild steel and special non-ferrous metals and their alloys.
- Use with our polishing pastes making sure not to use different pastas on the same roll.
- For polishing, we should be fitted on our polisher 2 pieces of felt wheels.
- Caution: for use on the polisher, provide two rolls at a time, unless you have the appropriate spacers.
- Polishing procedure: 1-white paste 411 00 17490-4385 / B. 2- blue paste 00 17500-4385 411 / B. 3-pink paste 411 00 17510-4385 / R

Code	Desc.	Width mm	Ø mm	Foro centr. mm
3420000260	14/F	50	100	19

## Cotton disks soft polisher



- Discs in soft cotton for the final polishing of metal surfaces with mirror chrome effect. Center hole of 19 mm for mounting on the type polishers our code 417 00 11400-PTX500.
- The special very soft fiber allows a high luster without leaving signs, halos and shadows on the machined surface.
- For polishing, we should be fitted on our polisher 10 discs.
- Use with our polishing pastes making sure not to use different pastas on the same roll.
- Polishing procedure: 1-white paste 411 00 17490-4385 / B. 2- Blue paste 411 00 17500-4385 / B. 3-paste pink 411 00 17510-4385 / R



Code	Desc.	Width mm	Ø mm	Foro centr. mm
3420000270	15/C	10	100	19

## Set spacer rings for polisher



- Set of plastic spacer rings created specifically for use on all polishers with shaft diameter 19 mm single or double key, type our code 417 00 11400-PTX500.
- The use of the rings allows the use of the rollers in felt and cotton discs individually, without having to reach the number required to fill the machine shaft.
- The kit includes two spacers 20 mm and 10 mm, for a total thickness of 50 mm.

Code	Desc.
3420000400	32

## Roller for abrasive belts



- Roller for abrasive belts and felt for sanding, satin-finishing and high-gloss polishing of metal pipes or stainless steel.
- Suitable for use on all machines polishers with shaft diameter 19 mm single or double stick, like our item code. 417 00 11400-PTX500.
- Mainly used in machining of stainless steels in carpentry, industry, marine, in the body of transformation vehicles.
- The roller mounted on the machine burnishing allows to drag the abrasive belts or polishing along the whole perimeter of the pipe, allows the removal of weld beads, steps, rust and oxides. The satin finish of every size and bright polishing surface through the use of special polishing paste.
- Surface covered with non-slip material, anti-oil and anti-wear, metal flanges steel side to prevent leakage of the tapes. Diameter of the rubber 85 mm, width 70 mm.

Code	Desc.
3420000340	29

## Abrasive tapes for polishing pipe



- Abrasive tapes for polishing of metal pipes and stainless steel, through the use of machine calenders and our drive roller code 342 00 00340-29.
- Indicated in the machining of metal pipes of all kinds including stainless steel in the areas of carpentry, industry, marine, in the body of transformation vehicles.
- Indispensable to remove the weld beads, steps, rust and oxide, as a preparation for the next operations of satin finishing or mirror polishing along the entire perimeter of the tubing.
- The belts 30 x 600 mm. easy to open, resealable and serviceable with our duct tape code 342 00 00450-34.

Code	Desc.	Grain	Sviluppo mm
3440205010	PTX60	60	30x600
3440205020	PTX80	80	30x600
3440205040	PTX120	120	30x600
3440205050	PTX150	150	30x600
3440205060	PTX180	180	30x600
3440205070	PTX240	240	30x600

## Abrasive tapes finishing opened



- Abrasive tapes finishing opened for sanding, satin-finishing and preparation for polishing of metal pipes and stainless steel, through the use of machines polishers and our drive roller code 342 00 00340-29.
- Indicated in the machining of metal pipes of all kinds including stainless steel in the areas of carpentry, industry, marine, in the body of transformation vehicles.
- The tapes can also be used in structures are completely closed, the closure system slotted it assures the reliability and the perfect operation.
- Ideal for the preparation to painting or plating treatments, for satin finishing of stainless steel and other metals, for the preparation to the next stage of polishing with felt strips and the appropriate pastes.



Code	Desc.	Grain	Color	Sviluppo mm
3440205080	PTX/C	Coarse	Brown	30x660
3440205090	PTX/M	Medium	Red	30x660
3440205100	PTX/F	Fine	Blue	30x660
3440205110	PTX/VF	Very fine	Grey	30x660

## Felt tapes for polishing opened



- Felt tapes development 660 x 30 x 5 mm, open design with closing slotted for high-gloss polishing of pipes and handrails in housings.
- Indicated in the machining of metal pipes of all kinds including stainless steel in the areas of carpentry, industry, marine, in the body of transformation vehicles.
- They are used on both sides in combination with the satin-finishing machines, with the special paste for polishing.
- It is recommended not to use different pastas on the same felt to avoid contamination and defects in workmanship.

Code	Desc.	Sviluppo mm
3420000350	30	30x660



## Duct tape to repair abrasive tapes



- Special reinforced adhesive tape for closing, the construction and repair of the abrasive tapes for closed sander.
- It allows to open and close the tape on closed buildings, build tapes joining many together, repair tapes that have opened during processing.
- The adhesive tape must be applied along the length of the abrasive, superimposing it at the end of about one centimeter.

Code	Desc.	Roll size
3420000450	34	50m x 25mm

## Wheels in cloth for polishing



- Wheel ventilated cotton cloth mounted on stationary or grinders with shank diameter 6 mm for mounting on drills or straight grinders, useful for cleaning and polishing of all metals, lacquered wood, painted materials.
- For small workshops plumbing, mechanics, carpentry, and maintenance industries.
- The wheels with hole have a thickness of 12 mm. and they can be mounted side by side on the shaft of the machine up to create the roller of the desired size.
- They are used with pasta and polish specific, such as our pasta in pats codd. 411 00 17 490 white, 411 00 411 00 17510 17500 blue and pink.
- Observe recommended maximum speed.

Code	Desc.	Ø mm	Thickness mm	Ø foro centrale mm	Density	Revolutions/min.
3420000330	28	80	10	Stem 6x27	90	4000
3420000320	27	150	12	16-20	160	4000
3420000310	26	200	12	20	230	4000

## Circular brush steel wire



- Corrugated steel wire high strength.
- Suitable for deburring, satin finishing and polishing, to remove rust and metal cleaning.

Code	Desc.	Ø mm	Ø hole mm	Thickness mm	Ø filo mm	Vel. max giri/min.
4430042700	477 - 150x16	150	16	22	0.30	6000
4430042710	477 - 150x20	150	20	22	0.30	6000
4430042800	477 - 200x20	200	20	22	0.30	4500
4430042810	477 - 250x25	250	25	26	0.30	3600

## Round brushes in twisted knots



- With steel wire twisted knots.
- Aggressive to work at high rotation speed.
- Suited for the preparation and finishing of continuous welds, burrs, and the mechanical pickling (rust, paint, resins).
- \* With nut for portable grinders.

Code	Desc.	Ø mm	Ø hole mm	Thickness mm	Ø filo mm	Vel. max giri/min.
4430047120	779 - 115	115	M14*	12	0.50	12500
4430047122	779 - 150	150	16	20	0.50	9000
4430047124	779 - 200	200	20	18	0.50	9000

## Cup brushes steel wire



- With wire of corrugated steel.
- Suitable for removing rust, scale etc ..
- Employee of grinders.

Code	Desc.	Ø mm	Ø hole mm	Ø filo mm	Vel. max giri/min.
4430047126	780 - 100	100	M 14 *	0.30	8500
4430047128	780 - 150	150	M 14 *	0.30	6000

## Cup Brushes with twisted knots



- With twisted knots steel wire.
- To eliminate waste, rust, paint, deadening and heavily burned.
- Use of angle grinders or stationary machines.
- Extremely robust and aggressive.
- When the coils are worn, remove the metal ring to be able to still use the brush.

Code	Desc.	Ø mm	Ø hole mm	Ø filo mm	Vel. max giri/min.
4430047130	781 - 85	85	M 14 *	0.50	8500
4430047132	781 - 105	105	M 14 *	0.50	6000

## Brush conical twisted knots



- A twisted knots in steel wires.
- Suitable for cleaning work on uneven surfaces, with edges and cracks.
- For severe scrapes, slag, rust, deadening.
- Use of angle grinders or stationary machines.

Code	Desc.	Ø mm	Ø hole mm	Ø filo mm	Vel. max giri/min.
4430047134	782 - 95	95	M 14	0.50	13500

4

## Brush with tapered shank twisted knots



- Shank for use with drill or straight grinder.
- A twisted knots in steel wires.
- Suitable for cutting jobs on uneven surfaces, with edges and cracks.
- For severe scrapes, slag, rust, deadening.

Code	Desc.	Ø mm	Stem mm	Ø filo mm	Vel. max giri/min.
4430047136	783 - 95	95	6x25	0.35	6500

## End Brushes

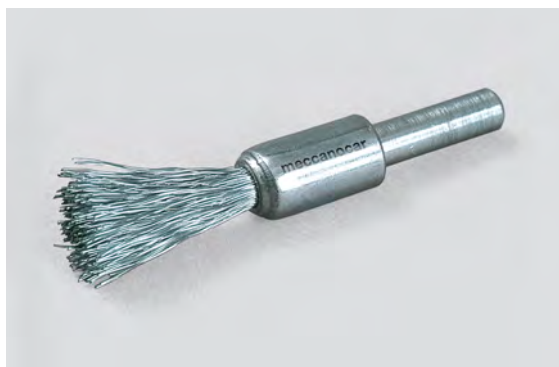

- Corrugated steel for frontal work.
- Used with power tools or air.

Code	Desc.	Ø mm	Stem mm	Ø filo mm	Vel. max giri/min.
4430027900	345	10	6x25	0.30	20000
4430028100	347	15	6x25	0.30	18000
4430028300	349	20	6x25	0.30	18000
4430028500	351	25	6x25	0.30	18000
4430028700	353	30	6x25	0.30	15000
4430028000	346	10	6x80	0.30	18000
4430028200	348	15	6x80	0.30	18000
4430028400	350	20	6x80	0.30	18000
4430028600	352	25	6x80	0.30	18000

## Brushes brush type fungus

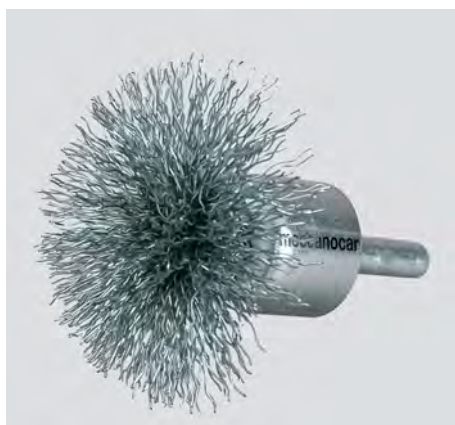

- Corrugated steel for frontal and work at very high speed.
- Elimination of burrs, slag and paint.
- Ideal for cleaning of inner surfaces difficult to access.

Code	Desc.	Ø mm	Stem mm	Ø filo mm	Vel. max giri/min.
4430028800	354	30	6x25	0.30	18000
4430029000	356	40	6x25	0.30	18000
4430029200	358	50	6x25	0.30	18000
4430028900	355	30	6x80	0.30	18000
4430029100	357	40	6x80	0.30	18000

## Small brush with flexible stem



- Corrugated steel to work hard to reach.
- Ideal for burrs, elimination of waste and paints.

Code	Desc.	Ø mm	Stem mm	Ø filo mm	Vel. max giri/min.
4430029900	365	50	6x180	0.30	12000

## Small brush with twisted knots



- Suitable for work at very high speed.
- To remove smudges and paints.

Code	Desc.	Ø mm	Stem mm	Ø filo mm	Vel. max giri/min.
4430047490	792 - 30	30	6x18	0.50	20000

## Round brushes with shank



- Corrugated steel high strength.
- With high density of wires.
- Excellent strength and durability.

Code	Desc.	Ø mm	Stem mm	Ø filo mm	Vel. max giri/min.
4430029300	359	20	6x25	0.20	10000
4430029400	360	30	6x25	0.20	10000
4430029500	361	40	6x25	0.30	10000
4430029600	362	50	6x25	0.30	7500
4430029700	363	60	6x25	0.30	6000
4430029710	363 - 70	70	6x25	0.30	4500
4430029720	363 - 80	80	6x25	0.30	4500
4430029730	363 - 100	100	6x25	0.30	4500

## Circular brush with shank twisted knots



- In high-strength steel.
- Very aggressive brush to remove paint, deadening and smudges welding.

Code	Desc.	Ø mm	Stem mm	Ø filo mm	Vel. max giri/min.
4430029800	364	70	6x25	0.50	15000



## Cup brush corrugated steel



- Suitable for painting.
- For working in corners or harsh surfaces.
- High resistance.

Code	Desc.	Ø mm	Stem mm	Ø filo mm	Vel. max giri/min.
4430047138	784	70	6x25	0.30	6500

4

## Cup brush with twisted knots



- Suitable for heavy duty paint, deadening, acrylic.
- High resistance.

Code	Desc.	Ø mm	Stem mm	Ø filo mm	Vel. max giri/min.
4430047140	785	70	6x25	0.30	6000

## Brushes wire stainless steel A2

- Brushes wire stainless steel A2.
- Particularly suitable for processing stainless steel and aluminum.
- For all polishing work, glazing and polishing.

## Round brushes A2 stainless steel for bench grinders



Code	Desc.	Ø Est. mm	Ø hole mm	Ø filo mm	Vel. max giri/min.
4430042702	477A2-150X25	150	16	0,30	6000
4430042802	477A2-200X25	200	20	0,30	4500



## Round brushes stainless steel A2 to twisted knots



- With nut M14 for use of grinders.

Code	Desc.	Ø Est. mm	Ø hole mm	Ø filo mm	Vel. max giri/min.
4430047121	779A2-115	115	M14	0,50	12500

## Brushes conical A2 stainless steel wire, corrugated



Code	Desc.	Ø Est. mm	Ø hole mm	Ø filo mm	Vel. max giri/min.
4430047125	780A2-80	80	M14	0,30	11000
4430047127	780A2-100	100	M14	0,30	8500
4430047129	780A2-120	120	M14	0,30	6500

## Cup Brushes A2 stainless steel ring with a twisted knots



- When the brush is worn, remove the metal ring to use it yet.

Code	Desc.	Ø Est. mm	Ø hole mm	Ø filo mm	Vel. max giri/min.
4430047131	781A2-70	70	M14	0,50	12500
4430047133	781A2-80	80	M14	0,50	8500
4430047135	781A2-100	100	M14	0,50	8500

## Brushes front A2 stainless steel brush

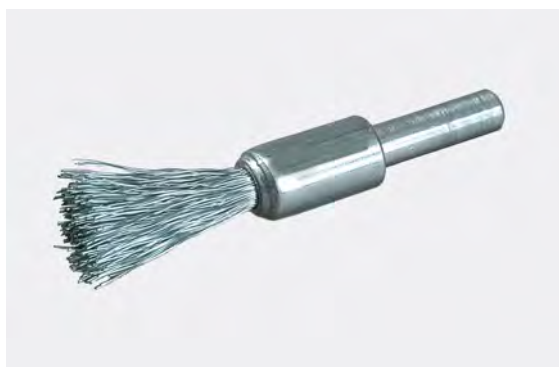

Code	Desc.	Ø Est. mm	Stem mm	Ø filo mm	Vel. max giri/min.
4430028102	347A2-15	15	6x25	0,30	20000
4430028302	349A2-20	20	6x25	0,30	20000
4430028502	351A2-25	25	6x25	0,30	20000
4430028702	353A2-30	30	6x25	0,30	20000

**Brushes brush stainless steel A2 to twisted knots**

Code	Desc.	Ø Est. mm	Stem mm	Ø filo mm	Vel. max giri/min.
4430047489	792A2-19	19	6X18	0,50	20000
4430047491	792A2-22	22	6X18	0,50	20000

**Round brushes A2 stainless steel shank**

Code	Desc.	Ø Est. mm	Stem mm	Ø filo mm	Vel. max giri/min.
4430029602	362A2-50	50	6X25	0,30	4500
4430029702	363A2-60	60	6X25	0,30	4500
4430029712	363A2-70	70	6X25	0,30	4500
4430029722	363A2-80	80	6X25	0,30	4500

**Cup brushes in corrugated stainless steel A2**

Code	Desc.	Ø Est. mm	Stem mm	Ø filo mm	Vel. max giri/min.
4430047137	784A2-50	50	6X25	0,30	6500
4430047139	784A2-60	60	6X25	0,30	5000

**Abrasive disc vulcanized**

- Vulcanized steel wires embedded in special plastic material.
- Long duration.
- Uniform abrasion and maximum operational reliability.

Code	Desc.	Ø mm	Stem mm	Thickness mm	Vel. max giri/min.
4430047142	786	63	6x30	8	15000

## Brush vulcanized



- Vulcanized steel wires embedded in special plastic material.
- Long duration.
- Uniform abrasion and maximum operational reliability.

Code	Desc.	Ø mm	Stem mm	Vel. max giri/min.
4430047150	787	24	6x15	20000

## Round brushes Nylon abrasive



- They do not scratch and do not rust.
- You can be used on metal, wood, brick, stone, tile and concrete.
- Nylon grit 120.

Code	Desc.	Ø mm	Stem mm	Vel. max giri/min.
4430047152	787 - 75	75	6x30	4500
4430047154	788 - 100	100	6x30	4500

## Abrasive Nylon Cup Brushes



- They do not scratch and do not rust.
- You can be used on metal, wood, brick, stone, tile and concrete.
- Nylon grit 120.

Code	Desc.	Ø mm	Stem mm	Vel. max giri/min.
4430047156	789 - 50	50	6x30	4500
4430047158	789 - 75	75	6x30	4500

## Hand brushes curves



- Universal use.
- Ergonomic plastic handle.
- The high density of the wire and the reduced thickness allow to work in confined spaces.

Code	Desc.	Ø mm	Wire material	L mm
4430027700	343	0.30	STEEL BRASS	270
4430027710	343 A2	0.30	STAINLESS STEEL	270

## Brushes for welders



- Back and wooden handle.
- Steel wires tempered smooth  $\varnothing$  00:35.
- To remove rust, welding and smudges.

Code	Desc.	$\varnothing$ filo mm	L mm
4430027800	344	0.35	270

4

## Brushes strains brakes



- Suitable for leveling dirt and deposits.
- Strains on brake handle and plastic back.

Code	Desc.	$\varnothing$ filo mm	L mm
4430047492	793	0.35	225

## Brushes for spark plugs



- Suitable for the cleaning of the contacts spark plugs.
- Brass wire.

Code	Desc.	$\varnothing$ filo mm	L mm
4430047494	794	0.15	155



## Serie dischi abrasivi velcrati (Ø 150)

- AMPIA GAMMA DI DISCHI ABRASIVI A SUPPORTO FLESSIBILE DI DIAMETRO 150 IDONEA PER OGNI TIPO DI LAVORAZIONE.
- TRE FAMIGLIE DI DISCHI PER SODDISFARE QUALSIASI TIPO DI NECESSITA'.

	INDICATI PER:	VANTAGGI E CARATTERISTICHE:
<b>SERIE SUN</b>	CARROZZERIE AUTO/V.I., NAUTICA LAVORAZIONI DEL LEGNO (DURO)	<b>ALTA CAPACITA' D'ASPORTAZIONE</b> LA CARTA UTILIZZATA E' IN OSSIDO D'ALLUMINIO TRATTATA CON UNA SPECIALE ED INNOVATIVA STEARATURA CHE LA RENDE PIU' PERFORMANTE. <b>LUNGA DURATA DEL PRODOTTO</b> L'ABRASIVO E IL SUPPORTO DEL DISCO SONO ACCOPPIATI MEDIANTE UNO SPECIALE TRATTAMENTO CHE RENDE PIU' ELASTICO IL PRODOTTO E PIU'RESISTENTE SULLE SUPERFICI CURVE.
<b>SERIE MOON</b>	INDUSTRIA E LAVORAZIONI DEL METALLO E DEL LEGNO	<b>ALTA CAPACITA' D'ASPORTAZIONE</b> LA CARTA UTILIZZATA E' IN OSSIDO D'ALLUMINIO ESTREMAMENTE PERFORMANTE. LA VERSIONE A 7 FORI RENDE IL PRODOTTO VALIDO PER LAVORAZIONI ESTREMAMENTE RAPIDE. <b>AMPIA GAMMA D'UTILIZZO:</b> LA CARTA UTILIZZATA E IL SUPPORTO PERMETTONO DI POTER UTILIZZARE IL PRODOTTO SU VARIE TIPOLOGIE DI MATERIALI E LAVORAZIONI.
<b>SERIE MARS (TOP DI GAMMA):</b>	AUTOMOTIVE E NAUTICA, NELLE GRANE FINI PER QUALSIASI LAVORAZIONE DOVE SIA RICHIESTA UNA EFFICACE FINITURA	<b>ALTA CAPACITA' D'ASPORTAZIONE</b> LA CARTA UTILIZZATA E' IN OSSIDO D'ALLUMINIO TRATTATA CON UNA SPECIALE ED INNOVATIVA STEARATURA CHE LA RENDE PIU' PERFORMANTE. <b>AMPIA GAMMA D'UTILIZZO:</b> LA CARTA UTILIZZATA E IL SUPPORTO PERMETTONO DI UTILIZZARE IL PRODOTTO SU VARIE TIPOLOGIE DI MATERIALI E LAVORAZIONI, IN PARTICOLARE PER LE OPERAZIONI DI FINITURA CON GRANE FINI. <b>LUNGA DURATA DEL PRODOTTO:</b> LA CARTA E IL SUPPORTO DEL DISCO SONO ACCOPPIATI MEDIANTE UNO SPECIALE TRATTAMENTO CHE RENDE IL PRODOTTO PIU' ELASTICO E PIU'RESISTENTE SULLE SUPERFICI CURVE. IL SUPPORTO DELL'ABRASIVO E' IN FILM POLIESTERE CHE PERMETTE UN'ECCEZIONALE ELASTICITA'.



LA SCELTA DELLA CORRETTA GAMMA DA UTILIZZARE DIPENDE MOLTO DALLE PECULIARITA' D' UTILIZZO, MECCANOCAR SUGGERISCE LE SEGUENTI POSSIBILI APPLICAZIONI:

	Carrozzeria Auto/V.I.	Carrozzeria Auto/V.I.	Lavorazioni Metallo/Legno	Lavorazioni Metallo/Legno	Carrozzeria Auto/V.I. Nautica Lavorazioni Metallo	Carrozzeria Auto/V.I. Nautica Lavorazioni Metallo
GRANA	SERIE SUN 9 FORI	SERIE SUN 15 FORI	SERIE MOON 7FORI	SERIE MOON 9 FORI	SERIE MARS 15 FORI	SERIE MARS SENZA FORI
40	●	●	●	●		
60	●	●	●	●	●	
80	●	●	●	●	●	
100	●	●	●	●	●	
120	●	●	●	●	●	
150	●	●	●	●	●	
180	●	●	●	●	●	
220	●	●	●	●	●	
240	●	●	●	●	●	
280	●	●	●	●	●	
320	●	●	●	●	●	
360	●	●	●	●	●	
400	●	●	●	●	●	
500	●	●	●	●	●	
600	●	●	●	●	●	
800	●	●	●	●	●	
1000	●	●	●	●	●	
1200	●	●	●	●		●
1500	●	●	●	●		●
2000						●
2500						●
3000						●

TUTTI I DISCHI DELLA SERIE MECCANOCAR SONO ACCOPPIABILI CON I NOSTRI PLATORELLI E INTERFACCIE SOFFICE COME RIPORTATO A LATO

	DISCHI SENZA FORI	DISCHI 7 FORI	DISCHI 9 FORI	DISCHI 15 FORI
PLATORELLO VELCRATO	342 01 00400 - 20	342 01 00500 - 66/7	342 01 00600 - 66/9	342 01 02075 - 66/21
INTERFACCIA SOFFICE	QUALSIASI MODELLO	342 01 02060 - 67/7	342 01 02070 - 67/9	342 01 02080 - 67/21



**Velcro Abrasive disks Ø 150 series Sun**

- Designed for the field of autobody and industrial vehicles thanks to their high capacity of removal of materials and low propensity to clogging of the disc.
- The abrasive and support are coupled by a double phenol resin which guarantees a perfect seal of the product also in big trouble.
- The disc consists in a lightweight paper in grits from 150 to 1500 and a more heavy from 40 to 120 guarantees excellent performance in all stages of processing.
- The abrasive used an aluminum oxide surface treated with a stearatura designed for the automotive industry which makes it great also in the machining of products more "hard" as may be steel and wood.

4

Code	Desc.	Grain	Type
3340201000	150X40/S	P40	Abrasive disks sun 9 holes (8 + central)
3340201010	150X60/S	P60	Abrasive disks sun 9 holes (8 + central)
3340201020	150X80/S	P80	Abrasive disks sun 9 holes (8 + central)
3340201030	150X100/S	P100	Abrasive disks sun 9 holes (8 + central)
3340201040	150X120/S	P120	Abrasive disks sun 9 holes (8 + central)
3340201050	150X150/S	P150	Abrasive disks sun 9 holes (8 + central)
3340201060	150X180/S	P180	Abrasive disks sun 9 holes (8 + central)
3340201070	150X220/S	P220	Abrasive disks sun 9 holes (8 + central)
3340201080	150X240/S	P240	Abrasive disks sun 9 holes (8 + central)
3340201090	150X280/S	P280	Abrasive disks sun 9 holes (8 + central)
3340202000	150X320/S	P320	Abrasive disks sun 9 holes (8 + central)
3340202010	150X360/S	P360	Abrasive disks sun 9 holes (8 + central)
3340202020	150X400/S	P400	Abrasive disks sun 9 holes (8 + central)
3340202030	150X500/S	P500	Abrasive disks sun 9 holes (8 + central)
3340202040	150X600/S	P600	Abrasive disks sun 9 holes (8 + central)
3340202050	150X800/S	P800	Abrasive disks sun 9 holes (8 + central)
3340202060	150X1000/S	P1000	Abrasive disks sun 9 holes (8 + central)
3340202070	150X1200/S	P1200	Abrasive disks sun 9 holes (8 + central)
3340202080	150X1500/S	P1500	Abrasive disks sun 9 holes (8 + central)
3340600010	150X40/S	P40	Abrasive disks sun 15 holes (14 + central)
3340600020	150X60/S	P60	Abrasive disks sun 15 holes (14 + central)
3340600030	150X80/S	P80	Abrasive disks sun 15 holes (14 + central)
3340600040	150X100/S	P100	Abrasive disks sun 15 holes (14 + central)
3340600050	150X120/S	P120	Abrasive disks sun 15 holes (14 + central)
3340600060	150X150/S	P150	Abrasive disks sun 15 holes (14 + central)
3340600070	150X180/S	P180	Abrasive disks sun 15 holes (14 + central)
3340600080	150X220/S	P220	Abrasive disks sun 15 holes (14 + central)
3340600090	150X240/S	P240	Abrasive disks sun 15 holes (14 + central)
3340600100	150X280/S	P280	Abrasive disks sun 15 holes (14 + central)
3340600110	150X320/S	P320	Abrasive disks sun 15 holes (14 + central)
3340600120	150X360/S	P360	Abrasive disks sun 15 holes (14 + central)
3340600130	150X400/S	P400	Abrasive disks sun 15 holes (14 + central)
3340600140	150X500/S	P500	Abrasive disks sun 15 holes (14 + central)
3340600150	150X600/S	P600	Abrasive disks sun 15 holes (14 + central)
3340600160	150X800/S	P800	Abrasive disks sun 15 holes (14 + central)
3340600170	150X1000/S	P1000	Abrasive disks sun 15 holes (14 + central)
3340600180	150X1200/S	P1200	Abrasive disks sun 15 holes (14 + central)
3340600190	150X1500/S	P1500	Abrasive disks sun 15 holes (14 + central)

## Velcro Abrasive disks Ø 150 series Moon



- The abrasive disks moon series are particularly suitable for industries, metal and wood thanks to their high capacity of removal materials and low propensity to clogging of the disc.
- The disc support, lightweight type, makes the product extremely performante especially in fine grains (150 to 1500).
- The abrasive in aluminum oxide.



Code	Desc.	Grain	Type
3340200150	150X40	P40	Abrasive Disks Moon 9 Holes (8 + Central)
3340200160	150X60	P60	Abrasive Disks Moon 9 Holes (8 + Central)
3340200180	150X100	P100	Abrasive Disks Moon 9 Holes (8 + Central)
3340200190	150X120	P120	Abrasive Disks Moon 9 Holes (8 + Central)
3340200210	150X180	P180	Abrasive Disks Moon 9 Holes (8 + Central)
3340200220	150X220	P220	Abrasive Disks Moon 9 Holes (8 + Central)
3340200230	150X240	P240	Abrasive Disks Moon 9 Holes (8 + Central)
3340200240	150X280	P280	Abrasive Disks Moon 9 Holes (8 + Central)
3340200250	150X320	P320	Abrasive Disks Moon 9 Holes (8 + Central)
3340200260	150X360	P360	Abrasive Disks Moon 9 Holes (8 + Central)
3340200270	150X400	P400	Abrasive Disks Moon 9 Holes (8 + Central)
3340200280	150X500	P500	Abrasive Disks Moon 9 Holes (8 + Central)
3340200290	150X600	P600	Abrasive Disks Moon 9 Holes (8 + Central)
3340200300	150X800	P800	Abrasive Disks Moon 9 Holes (8 + Central)
3340200310	150X1000	P1000	Abrasive Disks Moon 9 Holes (8 + Central)
3340200320	150X1200	P1200	Abrasive Disks Moon 9 Holes (8 + Central)
3340200330	150X1500	P1500	Abrasive Disks Moon 9 Holes (8 + Central)
3340100150	150X40	P40	Abrasive Disks Moon 7 Holes (6 + Central)
3340100160	150X60	P60	Abrasive Disks Moon 7 Holes (6 + Central)
3340100170	150X80	P80	Abrasive Disks Moon 7 Holes (6 + Central)
3340100180	150X100	P100	Abrasive Disks Moon 7 Holes (6 + Central)
3340100190	150X120	P120	Abrasive Disks Moon 7 Holes (6 + Central)
3340100200	150X150	P150	Abrasive Disks Moon 7 Holes (6 + Central)
3340100210	150X180	P180	Abrasive Disks Moon 7 Holes (6 + Central)
3340100220	150X220	P220	Abrasive Disks Moon 7 Holes (6 + Central)
3340100230	150X240	P240	Abrasive Disks Moon 7 Holes (6 + Central)
3340100240	150X280	P280	Abrasive Disks Moon 7 Holes (6 + Central)
3340100250	150X320	P320	Abrasive Disks Moon 7 Holes (6 + Central)
3340100260	150X360	P360	Abrasive Disks Moon 7 Holes (6 + Central)
3340100270	150X400	P400	Abrasive Disks Moon 7 Holes (6 + Central)
3340100280	150X500	P500	Abrasive Disks Moon 7 Holes (6 + Central)
3340100290	150X600	P600	Abrasive Disks Moon 7 Holes (6 + Central)
3340100300	150X800	P800	Abrasive Disks Moon 7 Holes (6 + Central)
3340100310	150X1000	P1000	Abrasive Disks Moon 7 Holes (6 + Central)
3340100320	150X1200	P1200	Abrasive Disks Moon 7 Holes (6 + Central)
3340100330	150X1500	P1500	Abrasive Disks Moon 7 Holes (6 + Central)

**Velcro Abrasive disks Ø 150 series Mars**

- The abrasive disks Mars series represent the top of the range offer Meccanocar and are particularly suitable for marine, automotive and any activity 'where' request processing extremely efficient and accurate.
- The series Mars and 'produced with a particular media polyester film that minimizes the risk of rupture of the disc caused by machining of corners and uneven surfaces.
- The abrasive is an oxide of aluminum with double phenolic resin and special treatment which reduces to the maximum the clogging of the disc.
- The polyester film backing minimizes the overheating of the disk thus avoiding clogging during machining of soft materials (eg. The bottom or transparent). This feature makes it very useful in the marine industry for the gel coat surfaces.
- Grit: from 60 to 15 holes in 1000 (particularly suitable for automotive and marine).
- Grain from 1200 to 3000 without holes (indicated in all finishing processes or polishing)

Code	Desc.	Grain	Puncture	Type
3340601000	150X60/M	P60	15 holes	ABRASIVE MARS DISKS
3340601010	150X80/M	P80	15 holes	ABRASIVE MARS DISKS
3340601020	150X100/M	P100	15 holes	ABRASIVE MARS DISKS
3340601030	150X120/M	P120	15 holes	ABRASIVE MARS DISKS
3340601040	150X150/M	P150	15 holes	ABRASIVE MARS DISKS
3340601050	150X180/M	P180	15 holes	ABRASIVE MARS DISKS
3340601060	150X220/M	P220	15 holes	ABRASIVE MARS DISKS
3340601070	150X240/M	P240	15 holes	ABRASIVE MARS DISKS
3340601080	150X280/M	P280	15 holes	ABRASIVE MARS DISKS
3340601090	150X320/M	P320	15 holes	ABRASIVE MARS DISKS
3340601100	150X360/M	P360	15 holes	ABRASIVE MARS DISKS
3340601110	150X400/M	P400	15 holes	ABRASIVE MARS DISKS
3340601120	150X500/M	P500	15 holes	ABRASIVE MARS DISKS
3340601130	150X600/M	P600	15 holes	ABRASIVE MARS DISKS
3340601140	150X800/M	P800	15 holes	ABRASIVE MARS DISKS
3340601150	150X1000/M	P1000	15 holes	ABRASIVE MARS DISKS
3340000020	150X1500/M	P1500	without holes	ABRASIVE MARS DISKS
3340000030	150X2000/M	P2000	without holes	ABRASIVE MARS DISKS
3340000040	150X2500/M	P2500	without holes	ABRASIVE MARS DISKS
3340000050	150X3000/M	P3000	without holes	ABRASIVE MARS DISKS

## Velcro Abrasive disks with soft sponge



- Velcro abrasive disks drilled diameter of 150 mm for finishing operations prior to painting, corrections of defects and matting of paints. They allow fast machining with considerable saving of time without the use of soft interfaces.
- Suitable for machining preparation for painting, correcting defects of large entities and preparation for polishing of old paint in bodywork.
- Product with a long duration and the extreme practicality, allows to speed machining typically made by hand or using chemical products. Possibility of use in dry or wet, with machines or with random orbital sanding pads velcro hand.

Code	Description	Diameter mm	Grain	Grana P
3340101000	10M	150	Medium	500
3340101010	10F	150	Fine	800
3340101020	10SF	150	Superfine	1000
3340101030	10MF	150	Microfine	1500

## Velcro diskettes daisy D. 35 mm

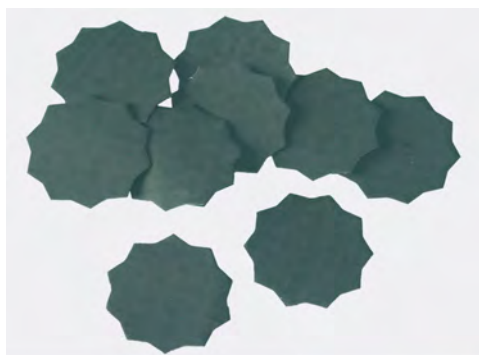

- Mini abrasive disks with Velcro attachment, large ultrafine, for the removal of all imperfections such as dirty, drippings, bubbles, etc.
- Usable both dry and wet swab using the appropriate dual surface, hard and soft.
- The grain used allows excellent surface finish.
- HOW TO USE:
- Make sure the paint surface is clean and free of dust.
- Lightly wet with water the point to be treated.
- Apply the disk of one of the faces of the swab and go with light and circular until the elimination of imperfection.
- Subsequently treat with fine abrasive paste and polish to restore the original luster.



Code	Desc.	Grain	Article
3340100500	40x1200	1200	DAISY DISKETTE
3340100600	40x1500	1500	DAISY DISKETTE
3340100700	40x2000	2000	DAISY DISKETTE
3340100800	40x3000	3000	DAISY DISKETTE
3420102090	68	/	MANUAL PAD

## Blade remove dirty



- Special tool for removing paint defects such as dirty, drippings, bubbles, etc.
- The special carbide blade can remove the defect in one step, cutting sharply as a razor blade.
- After the cutting of the defect, just restore the original luster through a fine abrasive paste and polish.
- Supplied with special support magnetic, with a face to attack Velcro diskette diameter 35 mm.

Code	Desc.
3420102100	69

## Velcro abrasive diskettes diameter 75 mm



- Velcro abrasive diskettes without holes with plastic film backing tightness material.
- Suitable for sanding bodywork repairs cars, motorcycles, trucks, fiberglass boats. Particularly suitable for the processing of polyester fillers and plastics.
- Used dry or wet, they do not tear, do not crumble at the edges, long life without clogging. Lubrication and cooling of the machined surface excellent.
- For their use and should be combined with our mini random orbital sander air cod. 418 00 08120-5715 or, alternatively, the mini polisher - sander cod. 418 00 08130-5720.

Code	Desc.	Grain	Diam. mm
3340500050	75X120	120	75
3340500060	75X150	150	75
3340500070	75X180	180	75
3340500080	75X220	220	75
3340500100	75X280	280	75
3340500110	75X320	320	75
3340500130	75X400	400	75
3340500160	75X800	800	75
3340500190	75X1500	1500	75
3340500250	75X2500	2500	75



## Abrasive sponges double-sided



- Sponges super fluffy with abrasive on both faces for work preparation and finishing in the bodywork on complex surfaces. Use dry or wet mixing of fillers, resins and coatings.
- Suitable for machining preparation for painting, correcting defects of large entities and preparation for polishing of old paint in bodywork.
- The quality of the abrasive and the gluing system on the sponge support make the product highly flexible and able to adapt to any surface. The great life than similar products make it economically viable.
- The coloring of the abrasive facilitates the choice of the grain to use.



Code	Description	Grain	Grana P	Color	Measures (mm)
3420000460	35F	Fine	800	Brown	120 X 100 X 13
3420000470	35SF	Super fine	1000	Green	120 X 100 X 13
3420000480	35UF	Ultra fine	1500	Violet	120 X 100 X 13

## Sponge wipers coated abrasives



- Wipes with a soft sponge semi abrasive side, for preparatory works and finishing body on complex surfaces. Use dry or wet mixing of fillers, resins and coatings.
- Suitable for machining preparation for painting, correcting defects of large entities and preparation for polishing of old paint in bodywork.
- Studied the density of the foam allows the cloth to fit in all the curved surfaces of the body. The whole is joined to a pleasantness to the touch that has no equal, for the best control the abrasive action by the operator.
- The consistency of the support allows to work in all areas of difficult access. The coloring of the abrasive facilitates the choice of the grain to use.

Code	Description	Grain	Grana P	Color	Measures (mm)
3420000490	36M	Medium	500	Grey	137 X 115 X 5
3420000500	36F	Fine	800	Orange	137 X 115 X 5
3420000510	36SF	Super fine	1000	Blue	137 X 115 X 5
3420000520	36UF	Ultra fine	1500	Green	137 X 115 X 5
3420000530	36MF	Micro fine	2500	Grey	137 X 115 X 5

## Abrasive sponges



- Abrasive synthetic fiber.
- To finish treatment of normal or orbital sander.
- For wood, metal, plastics, leather and glass.

Code	Desc.	Grain	Formato mm	Color
3420000010	1-120x280	FINE	120x280	Brown
3420000020	2-120x280	ULTRA FINE	120x280	Grey

4

## Rolls-waste soft abrasive



Costruito con gommapiuma sul retro

- Roll of paper dry abrasive coupled to foam at the back, for sanding hand finishing of car bodies.
- Great for finishing of body parts in areas rounded concave or convex.
- The construction with foam rubber eliminates any problem of sanding marks, allowing to distribute the pressure of the fingers of the hand in a uniform manner.
- Paper support highly flexible, semi-open coating process, abrasive aluminum oxide treated with stearate anti-clogging special.
- Supplied in packs of 115 mm. x 25 meters, pre-cut to 125 mm

Code	Desc.	Article
3460002000	150 S	115 mm.x25 meters P150
3460002010	180 S	115 mm.x25 metersP180
3460002020	220 S	115 mm.x25 meters P220
3460002030	240 S	115 mm.x25 meters P240
3460002040	280 S	115 mm.x25 meters P280
3460002050	320 S	115 mm.x25 meters P320
3460002060	360 S	115 mm.x25 meters P360
3460002070	400 S	115 mm.x25 meters P400
3460002080	500 S	115 mm.x25 metersP500
3460002090	600 S	115 mm.x25 meters P600
3460002100	800 S	115 mm.x25 metersP800
3460002120	1000 S	115 mm.x25 metersP1000

## Abrasive strips with Velcro and holes - 127x72 mm



- Pre-cut strips of abrasive paper with Velcro and holes for use by hand with the relevant pads.
- Suitable for use in bodywork, fibreglass working, carpentry, metal working, etc.
- Clog-proof stearate coated paper with ultra-strong backing, for durable use and a lack of powdering on the abrasives. Excellent grip over Velcro surface, holes for dust extraction during machining.
- Available in the best used measurements with classic hole sizes.

Code	Desc.	Grana P
3460002300	40/127x72	40
3460002310	60/127x72	60
3460002320	80/127x72	80
3460002330	100/127x72	100
3460002340	120/127x72	120
3460002350	150/127x72	150
3460002360	180/127x72	180
3460002370	220/127x72	220
3460002380	240/127x72	240
3460002390	280/127x72	280
3460002400	320/127x72	320
3460002410	360/127x72	360
3460002420	400/127x72	400



## Abrasive strips with Velcro and holes - 190x72 mm



- Pre-cut strips of abrasive paper with Velcro and holes for use by hand with the relevant pads.
- Suitable for use in bodywork, fibreglass working, carpentry, metal working, etc.
- Clog-proof stearate coated paper with ultra-strong backing, for durable use and a lack of powdering on the abrasives. Excellent grip over Velcro surface, holes for dust extraction during machining.
- Available in the best used measurements with classic hole sizes.

Code	Desc.	Grana P
3460002450	40/190x72	40
3460002460	60/190x72	60
3460002470	80/190x72	80
3460002480	100/190x72	100
3460002490	120/190x72	120
3460002500	150/190x72	150
3460002510	180/190x72	180
3460002520	220/190x72	220
3460002530	240/190x72	240
3460002540	280/190x72	280
3460002550	320/190x72	320
3460002560	360/190x72	360
3460002570	400/190x72	400

## Abrasive strips with Velcro and holes - 400x70 mm



- Pre-cut strips of abrasive paper with Velcro and holes for use by hand with the relevant pads.
- Suitable for use in bodywork, fibreglass working, carpentry, metal working, etc.
- Clog-proof stearate coated paper with ultra-strong backing, for durable use and a lack of powdering on the abrasives. Excellent grip over Velcro surface, holes for dust extraction during machining.
- Available in the best used measurements with classic hole sizes.

Code	Desc.	Grana P
3460002600	40/400x70	40
3460002610	60/400x70	60
3460002620	80/400x70	80
3460002630	100/400x70	100
3460002640	120/400x70	120
3460002650	150/400x70	150
3460002660	180/400x70	180
3460002670	220/400x70	220
3460002680	240/400x70	240
3460002690	280/400x70	280
3460002700	320/400x70	320
3460002710	360/400x70	360
3460002720	400/400x70	400

## Velcro universal Backing pads 150 mm

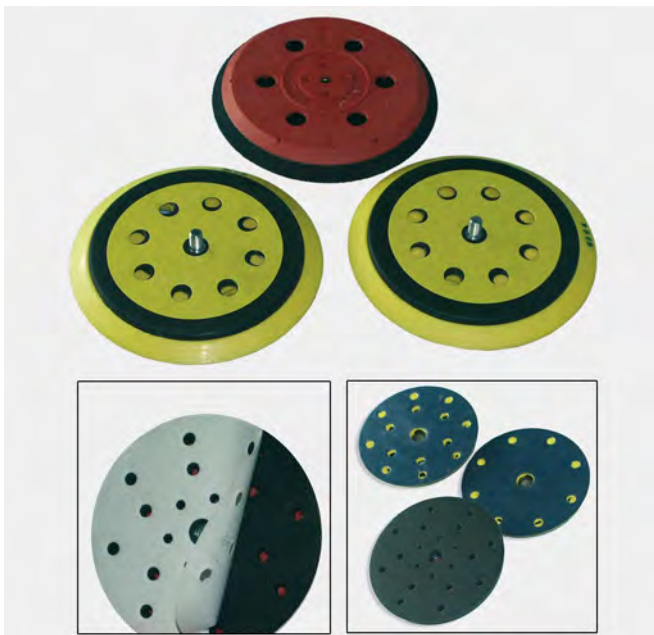

- Backing pads for application on orbital sanders, 150 mm diameter., Universal drilling for the use of discs with 6, 7, 9, 15 and 21 holes.
- Available with male connection 5/16 unf for our machines and 4180008270-5860 4180008280-5870, rupes machines and universal, and bayonet exclusive machine festo.

Code	Desc.	Attachment	For machines
3420100500	66/7	5/16 UNF	7 holes - Meccanocar, Rupes, universal
3420100600	66/9	5/16 UNF	9 holes - Meccanocar, Rupes, universal
3420102075	66/21	5/16 UNF	6-7-9-15-21 holes - Meccanocar, Rupes, including universal Festo
3420100400	20	5/16 UNF	Without holes



## Interfaces soft velcro



- Soft pads in foam rubber with double velcro, for mounting on all of velcro pads orbital sanders 150 mm diameter.
- Allow to quickly transform the hardness of a circular plate to adapt it to any type of processing. particularly suitable for machining of corners and edges.
- Increase the length of the pad and abrasive disks.
- Cushion thickness: 10 mm.



Code	Desc.	For pads
3420102060	67/7	Velcro 6-7 hole diameter 150 mm.
3420102070	67/9	Velcro 8-9 hole diameter 150 mm.
3420102080	67/21	Universal for diskette velcro 6-7-8-9-15-21 diameter holes 150

## Interface soft velcro 75 mm

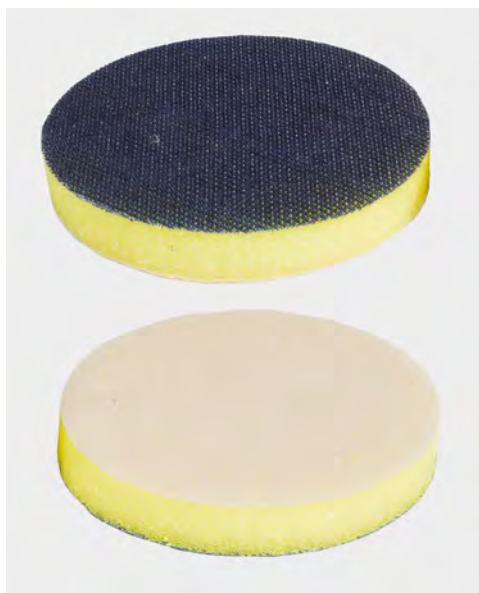

- Interface sponge with Velcro to the use of grinders or sanders which our codes 418 or 418 00 00 08120-5715 08130-5720 pad with diameter 75 mm. ideal for use of our discs velcro.
- Allows to vary at will the pressure on the machined surface and a uniform support of the abrasive allowing work more 'precise and longer life of a wild pads and abrasive disks.

Code	Desc.
3420102200	74



## Support for sanding



- Support for sanding by hand for use with abrasive discs to tear diameter 150mm. and not perforated.
- Product suitable for body shop, and metalworking in general.
- Suitable for sanding, roughing and satins hand of all metals.
- Ergonomic handle for work with less effort and in less time. product foam to fit all surfaces, also concave and convex

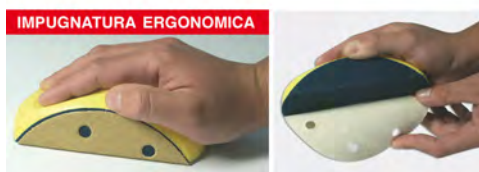

Code	Description
3420100050	50 - Support for sanding

## Support for sanding with extraction



- Support for hand sanding in foam material, complete with coupling for dust extraction, with tear-off surface for use with Velcro discs and any type of hole.
- Product recommended for use on vehicle bodywork, boats, carpentry, and metal working in general.
- Can be used for finish and rough sanding, as well as satin finishing of all metals.
- Ergonomic grip to work with less effort and save time, soft foam body, rotary coupling on the back for extraction of machining dust.
- Size: 200 x 85 x 55 mm.

Code	Desc.
3420102380	96

## Pad for hand sanding with extraction



- Rectangular pads for hand sanding in foam material, complete with coupling for dust extraction, with tear-off surface for use with Velcro abrasive strips, with or without holes.
- Products recommended for use on vehicle bodywork, boats, carpentry, and metal working in general.
- Can be used for finish and rough sanding, as well as satin finishing of all metals.
- Ergonomic grip to work with less effort and save time, soft foam body, rotary coupling on the back for extraction of machining dust.
- Size: large model 220 x 72 x 65 mm. Small model 160 x 72 x 62 mm.

Code	Desc.	Dim. piastra mm	N. holes
3420102450	103	192x70	8
3420102420	100	125x70	8

## Concave and convex interfaces for pads



- Bored interfaces with double Velcro fastening to convert the flat version of our pads, code no. 3420100070 and 3420100080 into concave or convex pads.
- Designed specifically to polish rounded surfaces in all sectors.

Code	Desc.	Dimensions	Form	N. holes
3420102460	104	192x70	Concave	8
3420102470	105	192x70	Convex	8
3420102430	101	125x70	Concave	8
3420102440	102	125x70	Convex	8

## Flat block file 70x400 mm with extraction



- Rectangular block file in nylon for hand sanding extensive flat surfaces, complete with coupling for dust extraction, with tear-off surface for use with Velcro abrasive strips, with or without holes.
- Products recommended for use on vehicle bodywork, boats, carpentry, and metal working in general.
- Ergonomic grip to work with less effort and save time. Rigid shockproof nylon body, polyurethane foam plate, rotary coupling on the back for extraction of machining dust.
- Size: 430 x 70 x 145 mm.

Code	Desc.	Dim. piastra mm	N. holes
3420102370	95	400x70	14

## Interfaces convexas pour tasseau-lime



- Interfaces convexas souples perforées et non-perforées pour l'emploi de notre tasseau-lime code 3420100310 avec surfaces arrondies.
- Prise à double Velcro pour l'emploi avec nos bandes Velcro pré-coupées.

Code	Desc.	Dimensione mm	N. holes
3420102410	99	400x70	14
3420102400	98	400x70	0

**Flexible round block 150 mm**

- Flexible block in polyurethane foam, with round shape, diameter 150 mm, Velcro coupling and handgrip knob.
- Designed for polishing and manual hand buffing operations, microfibre pads, wool pads, contamination remover discs, etc.
- Flexible edges allow the pad to follow any type of curved shape on the surface being processed. Comfy, practical handgrip for less operator fatigue.

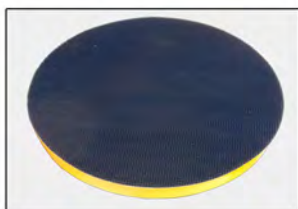

Code	Desc.	Diam. mm
3420102390	97	150

**Headphones lamb attack Velcro 180 mm**

- Domes lambswool 100% for polishing faster without overheating. velcro surface for quick installation.
- Built with rounded edges for added security and working to get into corners and edges.
- Two types of cut: light and medium. the first paint delicate, remove the marks left by the headphones more 'aggressive and combined with our fine abrasive gel cod. 411 00 17050-4190 can remove sanding scratches P1500-P2000. The average for conventional paints and hard, remove the marks left by the headphones more 'aggressive and combined with our fine abrasive gel code 411 00 17050-4190 can togliere signs of carteggiara P1200-P1500.

Code	Desc.	Diam. mm	Taglio	Ø attacco per platorello
3420102180	73/F	180	Medium	150
3420102190	73/L	180	Light	150

Particolare attacco velcro

**Tamponi in resina smussati attacco velcro per lucidatura**

- Tipo W8 colore arancio. Duro.
- Per operazioni di lucidatura (sgrossatura) con paste abrasive.
- Indicato per la sua durezza nel periodo estivo.

Code	Desc.	Measure mm
3420100810	41W8	160x60



- Type W65 tabacco color. Semi-hard.
- For polishing (roughing) with abrasive pastes.
- It indicated by its hardness in winter.

Code	Desc.	Measure mm
3420100820	41W65	160x60



- Type W5 yellow. Semi-soft.
- For polishing with abrasive paste polish or purposes.

Code	Desc.	Measure mm
3420100830	41W5	160x60



- Type W2 white. Soft.
- For polishing with abrasive paste polish or purposes.

Code	Desc.	Measure mm
3420100840	41W2	160x60



### Waffle polishing pad 160 mm



- Sponge pad with waffle surface and Velcro fastening. External diameter 160 mm, for polishing with all types of paste, polish and gel, with rotary and DA sanders.
- Recommended for rough polishing and polishing bodywork for all types of pain and gelcoat on fibreglass surfaces.
- Waffle surfaces have the dual purpose of keeping treated surfaces and pastes cold, prolonging the effectiveness and avoiding product waste. The waffle surface collects the excess paste and allow longer use compared to smooth pads.
- Available in a choice of three consistencies, distinguishable from the colour of the pads.

Code	Desc.	Dimensions mm	Consistency	Color
3420102490	107H	160 X 20	Hard	Blue
3420102500	107M	160 X 20	Medium	Grey
3420102510	107S	160 X 20	Soft	Purple

### Rusticated attack Velcro pads 75 mm



- Tampons resin ashlar with Velcro attachment 75 mm diameter for polishing of any type of painted surface or plastic.
- Usable by all the body shops for final polishing and correction of equipment of paint defects in small areas allowing for flawless finish and ultimate shine. natural parts of our headlight restoration kit code 411 00 18010-4645. W8 resin available in two densities: hard orange for use with abrasive paste large and medium for fast stock removal, soft blue color for use with polish pastes and final polishing for a great finish without signs.
- The indentation allows a perfect support of the area to avoid the formation of streaks and holograms. excellent cooling of the machined surface and pastes used.
- To use velcro pads are available our code 342 02230-76 01-M6 with M6 attack, and code 342 00 02240-76-5 / 16 with connection 5/16 "unf.

Code	Desc.	Color	Density
3420102210	75/D	Orange	Hard
3420102220	75/M	Light Blue	Soft



## Disco decontaminante premium 160 mm

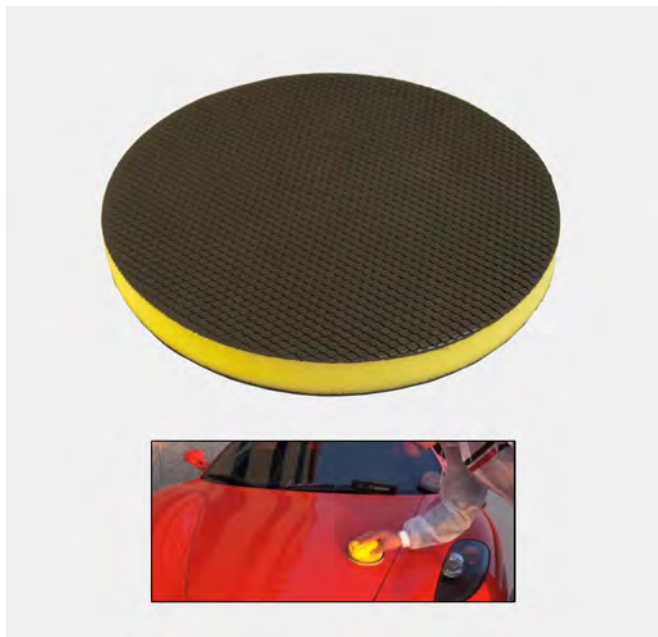

- Disco decontaminante con attacco velcro di diametro 160 mm per qualsiasi tipo di vernice, gelcoat, plastiche, cromature, cristalli. Permette di rimuovere in modo semplice e veloce fumi di verniciatura, macchie dovute all'acqua, resina di piante, sporco ferroviario, polvere dei freni, sporco ed inquinamento accumulatisi sulle carrozzerie.
- Indicato nelle carrozzerie per la decontaminazione prima della lucidatura, per le concessionarie ed i rivenditori auto per rinnovare le carrozzerie, nella nautica sulle imbarcazioni, nel settore moto, ecc.
- Di utilizzo semplicissimo, tramite lucidatrice rotorbitale o a mano con il nostro tassello rotondo codice 3420102490. La superficie da trattare deve essere pulita ed asciutta, deve essere lubrificata con il nostro Polish lucidante N-T codice 4110016600. Passare il disco decontaminante senza esercitare pressione su tutta la superficie fino a sentirla completamente liscia e libera da impurità.
- Il disco decontaminante può essere lavato con acqua e pulito dopo l'uso o nel caso cada per terra, può essere utilizzato tantissime volte ed è stato testato per il trattamento fino ad 80 automezzi.

Code	Desc.
3420102480	106

## Flexible 147 mm Velcro Backing pad.



- Backing pad for polishing and sander, female thread m14, velcro surface, suitable for the application of our pads resin cod. 342 01 or headphones in wool 150 mm diameter.
- The soft edge allows it to operate even in the corners and edges without damaging the paint.
- The construction foam improves the grip and absorbs the excess pressure on the machine sander / polisher.

Code	Desc.	Diam. mm	Female attachment
3420102160	71	147	M 14



## Velcro Backing pads diameter 75 mm



- Velcro Backing pads diameter 75 mm mounted and used on orbital sanders and polishers air.
- Indispensable for the use of abrasive disks and pads sponge.
- Available with two attachments to suit all machines on the market.
- Natural parts of our machines for grinding and polishing codes 418 00 and 418 00 08120 to 5715 from 08,130 to 5,720.
- Black pad with rigid support, interface foam rubber and male thread M6.
- yellow pad made of flexible foam, metal core and male thread 5/16 ".

Code	Desc.	Article
3420102230	76-M6	Backing pad black attack M6
3420102240	76-5/16	Yellow Backing pad attack 5/16 "(7.8 mm)

## Dust wiper "White Tampon"



- Dust wiper for painting, indispensable for the preparation of bodies of each vehicle.
- Indicated for body shops of light and heavy vehicles.
- Made of gauze, they are soaked in a special resin which removes any impurities' from the surfaces to be painted, has antistatic effect for preventing dust deposits, increases the adhesion of all types of paint improving the final result.
- Greatly reduces contamination of the paint dirt eliminating the formation of "nibs" and the need 'to touch up bodywork in painting completed.
- HOW TO USE:
- Wipe the surface to be painted after antisilicone, let it dry and paint a few seconds with the normal procedures.
- The cloth and 'disposable.

Code	Desc.	Gauze dimension mm	Pieces per package
4460008520	4120	800x350	5

## Dust wiper for water-based paints “White Tampon H2O”



- Dust cloth for painting with water paint, which is essential for the preparation of bodies of each vehicle. Indicated for autocarrozzerie of light and heavy vehicles.
- Made of gauze, are soaked in a special resin specially developed for modern water-based paints that removes any impurities' from the surfaces to be painted, has antistatic effect for preventing dust deposits, increases the adhesion of all types of paint by improving the final result.
- The resin contained substantially eliminates the possibility 'of sagging and the formation of orange peel.
- Greatly reduces contamination of the paint dirt eliminating the formation of "nibs" and the need 'to touch up bodywork in painting completed.
- HOW TO USE:
- Wipe the surface to be painted after antislicone, let it dry and paint a few seconds with the normal procedures.
- The cloth and 'disposable.

Code	Desc.	Gauze dimension mm	Pieces per package
4460008525	4130	800x350	5

## Cotone per lucidatura



- Cotone idrofilo bianco.
- Prodotto per pulizia e lucidatura in carrozzeria non si sfalda, non lascia peli sulle superfici.

Code	Desc.
4460008500	4100

## Eraser disk rubber 90 mm



- Lamellar caoutchouc disk for easy removal of double-sided adhesive films and plastic moldings and body.
- Used by auto body shops and VI, and anyone who needs to detach adhesive surfaces in plastic, glass and metal raw or painted quickly and without damaging the substrate.
- The special profile blades are designed to speed up the operation of detachment, cool the machined surface to prevent buckling, and avoid ovalization of the disc during use.
- For use of specific tools with female thread 5/16 "type our code. 418 00 06200, or drills or straight grinders through the adapter supplied.
- **WARNING:** Do not exceed the speed 'maximum of 4000 rev / min.

Code	Desc.	Article
3420102260	78	Eraser disk diameter 90 mm
3420102270	78/A	Adapter female threaded shank 6 mm.

## Kit discs caoutchouc



- Caoutchouc Disk mounted on a pivot for removal of residual glue, decals and moldings.
- This disk works on reduced speed (around 800 revolutions / minute).
- It is used with normal drills or straight grinders.
- The kit consisting of two caoutchouc disks and a pin for disk usage.

Code	Desc.	Revolutions/min.	Ø mm
3420102040	65 KIT	800	88

## Disk for pickling



- Disk of nylon fibers very resistant with embedded abrasive and a special binder.
- It is used on portable grinders also bringing more discs.
- Ideal for the removal of rust, for the cleaning of welds, for the removal of traces of paint, polyurethane and antinoise.

Code	Desc.	Ø mm	Ø hole mm	Grain	Velocità m./sec.
4940000100	100	100	13	LARGE	28/32
4940000150	150	150	13	LARGE	28/32

## Disco per decapaggio con perno



- Per decappaggio di ruggine, vernici, scorie, ecc..
- Disco di fibre di nylon molto resistenti con incorporato abrasivo e uno speciale legante.
- Si usa su smerigliatrici diritte o trapani.

Code	Desc.	Dimensions mm	Grain	Velocità m./sec.	Ø Perno
4940000250	100x13	100x13	GROSSA	28/32	6
4940000260	100x25	100x25	GROSSA	28/32	6
4940000270	150x13	150x13	GROSSA	28/32	8
4940000280	150x25	150x25	GROSSA	28/32	8

## Disk for pickling with fiber support



- Disk of nylon fibers very resistant with embedded abrasive and a special binder.
- For use on angle grinders
- Ideal for paint stripping, removing rust and oxidation on large surfaces, for cleaning of surfaces in concrete and stone
- Constant abrasive
- For use with sanding pad plastic n / s art. 339 00 01100-1150 (for discs Ø115) and n / s art. 339 00 01300 to 1800 (disc ø178)

Code	Desc.	Ø x foro mm	Velocità max
4940000300	115x22	115x22	10000

## Disco per decapaggio con supporto in fibra



- Disco di fibre di nylon con incorporato abrasivo e uno speciale legante.
- Si usa con smerigliatrici angolari portatili.
- Non necessita di platorello di rinforzo.
- Il supporto rigido in fibra consente una maggiore pressione di utilizzo e una azione più rapida e aggressiva.

Code	Desc.	Ø hole mm	Velocità max
4940000400	115x22	115x22	10000

## Finishing discs for “Unitized” surfaces



- Abrasive discs with glass fibre support made in pressed, non-woven fabric to sand and finish surfaces in all types of metal, including steel, aluminium and stainless steel.
- Recommended for all machining sectors where the an ultra-sine surface finish is required. These discs are able to remove oxidation and small welding beads as well as signs of previous sanding and polishing operations.
- Excellent durability, tear- and chalking resistance, free from clogging. Available in 115 mm diameter with standard central hole of 22.2 mm, three textures with a single ultra-fine grain.



Code	Density	Description	Grain	Velocità max giri/min
4940000950	Medio/Medium	115UM	Ultrafine	12.000
4940000960	Soffice/Soft	115US	Ultrafine	12.000
4940000970	Duro/Hard	115UD	Ultrafine	12.000



## Flat file for mechanics



- Bastard cut.
- Type parallel plate.

Code	Desc.	Sezione X L/mm
4430014410	240-150	16x4 150
4430014420	240-200	20x5 200
4430014430	240-250	25x6,5 250
4430014440	240-300	30x7,5 300

4

## Half round file for mechanics



- Bastard cut.

Code	Desc.	Sezione X L/mm
4430014510	241-150	16x5 150
4430014520	241-200	20x6,5 200
4430014530	241-250	25x8 250
4430014540	241-300	30x9 300

## Triangular file for mechanics



- Bastard cut.

Code	Desc.	Sezione X L/mm
4430014610	242-150	12 150
4430014620	242-200	15 200
4430014630	242-250	18 250
4430014640	242-300	21 300

## Lima square for mechanics



- Bastard cut.

Code	Desc.	Sezione X L/mm
4430014710	243-6x150	6 150
4430014720	243-8x200	8 200
4430014730	243-10x250	10 250
4430014740	243-12x300	12 300

## Round file for mechanics



- Bastard cut.

Code	Desc.	Sezione X L/mm
4430014820	244-6x150	6 150
4430014830	244-8x200	8 200
4430014840	244-10x250	10 250

## Lime bunch flat for mechanics



- Bastard cut.

Code	Desc.	L mm	N° pcs per bunch
4430046886	759-250	250	3
4430046888	759-300	300	2

## Wooden handle for files



- Waxed wood with brass ring reinforcement.

Code	Desc.	For files L/mm
4430014900	245-200	FROM 100 TO 150
4430014910	245-250	200
4430014920	245-300	250
4430014930	245-350	300

## Plastic handle for files



- Anatomic handle for a secure grip.

Code	Desc.	For files L/mm
4430045870	617-1	FROM 100 ATO 150
4430045872	617-2	200
4430045874	617-3	FROM 250 TO 350

## Series wood rasps



- Series 1 consists of parallel flat rasp. | 200 mm - 1 rasp half round the 200 mm - 1 rasp round the 200 mm.
- Plastic handle.
- Indispensable for retouches on wood and plastics.

Code	Desc.
4430045940	619-R

4

## Series files for mechanical munch



- Series consists of 1 flat file the 200 mm - 1 file half the 200 mm round - the round file 1 200 mm.
- Plastic handle.

Code	Desc.
4430045930	619

## Series keys for files



- Series consists of 6 pieces per 100 mm.
- Wooden handle.
- Plastic case.

Code	Desc.
4430014200	238

## Series files to contacts



- Series consists of 6 pieces.
- Plastic case.

Code	Desc.	Sezione X L/mm
4430014300	239	8,5x1 140





## Generic and specific fixing

Nylon fixing . . . . .	pag. 558	Fixings for pipes and thermohydraulics . . . . .	pag. 617
Fixing in steel and stainless steel . . . . .	pag. 584	Air conditioning brackets . . . . .	pag. 622
Chemical anchors and accessories. . . . .	pag. 604	Accessories for frames. . . . .	pag. 624
Nail guns and nailers. . . . .	pag. 614	Accessories for doors and gates . . . . .	pag. 629

## Standard nylon insert without border



- Tassello in nylon con espansione ampia ed uniforme tramite avvitamento di vite o accessorio con limitata coppia di serraggio.
- Per effettuare fissaggi leggeri su qualsiasi tipo di materiale pieno.
- Dotato di alette anti rotazione.
- Incavi esterni molto pronunciati per una migliore presa.
- Adatti per l'impiego con viti a legno per truciolare ns. art. 219 00 - BR - TR -

Code	Desc. Ø x L	Ø hole mm	Ø Vite consigliato mm
155TA00055	5x25	5	2,5-4
155TA00060	6x30	6	3,5-4
155TA00065	8x40	8	4,5-6
155TA00070	10x50	10	6-8
155TA00080	12x60	12	8-10
155TA00090	14x75	14	10-12

5

## Standard nylon insert with border



- Tassello in nylon con espansione ampia ed uniforme tramite avvitamento di vite o accessorio con limitata coppia di serraggio.
- Per effettuare fissaggi leggeri su qualsiasi tipo di materiale pieno.
- Dotato di alette anti rotazione.
- Incavi esterni molto pronunciati per una migliore presa.
- Adatti per l'impiego con viti a legno per truciolare ns. art. 219 00 - BR - TR -

Code	Desc. Ø x L	Ø hole mm	Ø Vite consigliato mm
155TA00100	5x26-B	5	2,5-4
155TA00200	6x31-B	6	3,5-4
155TA00400	8x41-B	8	4,5-6
155TA00500	10x50-B	10	6-8
155TA00530	12x60-B	12	8-10

## Standard nylon insert complete with screw, no border



- Stesse caratteristiche del ns. tassello standard senza bordo, ma completo di vite autofilettante per truciolare zincata, testa svasata piana con impronta a croce Pozidriv.

Code	Desc. Ø x L	Ø hole mm	Ø screw mm	Greatness imprint pz.
155TA00550	5X25-V	5	4X30	2
155TA00600	6X30-V	6	4,5X40	2
155TA00650	8X40-V	8	5X50	2
155TA00700	10X50-V	10	6X60	3

## Standard nylon insert complete with screw, with border



Code	Desc. Ø x L	Ø hole mm	Ø screw mm	Greatness imprint pz.
155TA00750	5X26-BV	5	4X30	2
155TA00800	6X31-BV	6	4,5X40	2
155TA00850	8X41-BV	8	5X50	2
155TA00870	10X51-BV	10	6X60	3



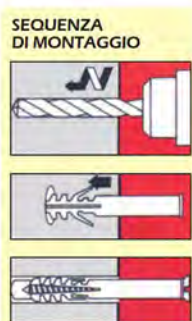

TASSELLI STANDARD IN NYLON						
Valori di estrazione in daN (1 daN = 1 Kg)						
MATERIALI DI SUPPORTO	Ø 5	Ø 6	Ø 8	Ø 10	Ø 12	Ø 14
Calcestruzzo R250 (250 kg/cm <sup>2</sup> )	160	240	360	720	880	1520
Mattoni pieni	60	150	200	280	330	400
Mattoni forati	60	60	80	80	80	100



**IMPORTANTE**  
I valori sono stati ottenuti con l'utilizzo di viti di Ø massimo applicabile. Applicare un coefficiente di sicurezza adeguato ad ogni singolo caso (4-5).

## Tassello universale in polipropilene con bordo



Foto B Foto A

Sequenza di montaggio

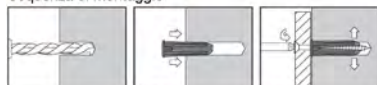

CARICHI DI ROTTURA (daN)		
Materiale	155 TA 09920	155 TA 09930
Calcestruzzo	50	60
Mattone pieno	40	50
Mattone forato	10	20

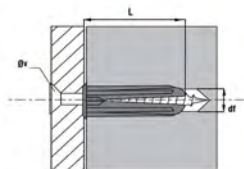

- Tassello universale in polipropilene per fissaggi leggeri.
- Utilizzabile per il fissaggio di interruttori elettrici, lampade, accessori bagno, mobili e pensili, strutture in legno e metallo, staffe, piastre, scaffalature.
- Settore di utilizzo: impiantisti termoidraulici e elettrici, montatori, carpenteria leggera.
- Pratica confezione (foto A) con gancio per collegarla alla cintola dell'operatore (foto B). Massima praticità per fare fissaggi dove non è possibile portare appresso la scatola.
- I differenti colori permettono di identificare velocemente i diversi diametri.
- Rispetto a tutti gli altri tasselli in nylon o polipropilene, per la sua applicazione è possibile una scelta più ampia di diametri delle viti.
- Utilizzabile su tutti i tipi di muratura mattoni pieni e forati, calcestruzzo, pietra, cartongesso.
- Con bordo che impedisce al tassello di entrare dentro il foro, ed alette antirotazione.
- Resistente agli agenti atmosferici, chimici e all'invecchiamento.

Code	Desc.	Ø Tassello mm	Screw Diam. mm (v)	Dowel length (L) mm	Hole diam. (df) mm	Color
155TA09920	6x25-UN	6	2,0-5,0	25	6	verde
155TA09930	8x30-UN	8	4,0-7,0	30	8	giallo

## Tassello universale in nylon con bordo completo di vite



- Tassello in nylon universale con bordo, caratteristiche come il precedente, ma già completo di vite autofilettante con testa svasata piana, impronta a croce Pozidriv, zincata.

Code	Desc. Ø x L	Ø hole mm	Screw dim. mm	Greatness imprint pz.
155TA04940	6X37 UBV	6	4X50	2
155TA04950	8X51 UBV	8	5X60	2
155TA04960	10X61 UBV	10	6X70	3

## SEQUENZA DI MONTAGGIO

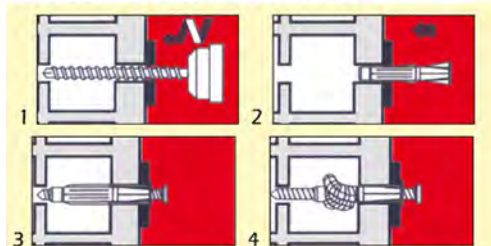

## IMPORTANTE

Applicare un coefficiente di sicurezza adeguato ad ogni singolo caso

### TASSELLI STANDARD IN NYLON FISSAGGIO A PERCUSSIONE

Valori di estrazione in daN (1 daN = 1 Kg)

MATERIALI DI SUPPORTO	Ø 5	Ø 6	Ø 8
Calcestruzzo R250 (250 kg/cm <sup>2</sup> )	90	140	180
Mattoni pieni	80	110	150

## Tassello universale in nylon con bordo



### Applicazioni:

- Tassello universale in nylon adatto ad ogni tipo di materiale.
- Speciale fissaggio sia su supporti pieni o forati.
- Ideale per il settore impiantistico.

### Caratteristiche:

- Corpo in nylon.
- Alette anti-rotazione durante l'avvitamento e bordo di tenuta.
- Su forati e cartongesso la struttura del tassello si flette su se stesso aumentando così il carico di fissaggio.
- Nel caso di supporti compatti, il funzionamento avviene per espansione uniforme creando attrito omogeneo sulle pareti del foro.

VALORI DI ESTRAZIONE		(1 daN = 1 Kg)	
Dim. vite/ Screw		3,5x45	4,5x60
Calcestruzzo/Concrete		95	190
Matt. pieno/Solid brick		55	130
Matt. forato/Hollow brick		80	95
Cartong. mm 10/Plasterb. mm 10		37	42

### INDICAZIONI DI POSA

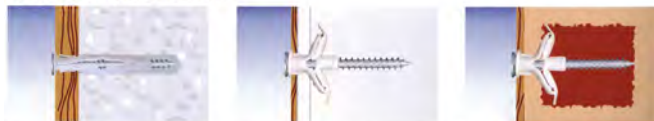

Espansione con aderenza su materiali compatti

Espansione con flessione su pareti vuote e mattoni forati.

Code	Description	Ø hole mm	Ø screw mm
155TA04980	6x45 UB - Tassello nylon	6	3,5-4,0
155TA04985	8x50 UB Tassello nylon	8	4,5-5,0

## Tassello universale in nylon con bordo completo di vite truciolare testa cilindrica



- Tassello in nylon completo di vite, avente le stesse caratteristiche come sopra, ma già completo di vite autofilettante testa cilindrica con impronta a croce zincata.

### INDICAZIONI DI POSA

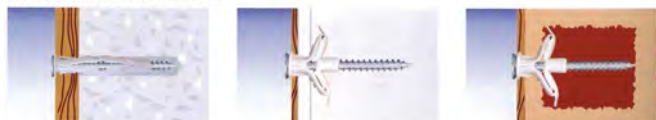

Espansione con aderenza su materiali compatti

Espansione con flessione su pareti vuote e mattoni forati.

Code	Description	Ø hole mm	Ø screw mm	Ø Testa Vite mm
155TA04990	6x45 UBV Tassello Nylon + Vite	6	3,5X45	10
155TA04995	8x50 UBV Tassello Nylon + Vite	8	4,5X60	10

## Tassello in nylon universale lungo TVZ

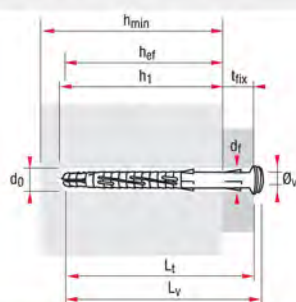

- $L_t$  = Lunghezza tassello
- $h_1$  = Profondità minima foro
- $d_0$  = diametro foro
- $T_{fix}$  = Spessore fissabile
- $\varnothing_v$  = Diametro vite
- $L_v$  = Lunghezza vite
- $d_f$  = Diametro foro nell'oggetto
- $h_{min}$  = spessore minimo del supporto
- $h$  = Spessore minimo da rispettare per installazioni su materiali cavi, somma di spessore fissabile ( $T_{fix}$ ) e spessore del materiale ( $h_{nom}$ , red)

- Tassello in nylon di tipo universale per fissaggi su superfici piene e vuote, con lunghezza prolungata per una presa migliore e più alte portate, disponibili nei diametri 6 ed 8 mm, completi di vite zincata TSP+ o senza vite.
- Indicati per fissaggi su: calcestruzzo, mattone pieno, semiforato o forato, cemento cellulare, blocchi in cemento vuoti, tramezze. Ideali per fissaggi generici di: carpenterie leggere, tende, accessori per bagno, lampade, quadri, antenne, mobili, pensili, staffe, canaline, ecc.
- Dotati di collarino e di alette antirotazione sottotesta, corpo speciale che favorisce la corretta espansione e l'annodamento del tassello nel vuoto.
- E' possibile l'utilizzo con qualsiasi tipo di vite autofilettante con filetto per legno o truciolare di lunghezza adeguata.

Dati per l'installazione							
Misura	$h_{min}$ mm	$d_0$ x $L_t$ mm	$\varnothing_v$ x $L_v$ mm	$h_1$ mm	$T_{fix}$ mm	$h_{ef}$ mm	$d_f$ mm
6x45	60	6x45	4,5x50	55	12	30	7
8x52	70	8x52	5,0x60	65	13	39	9

Carichi caratteristici di estrazione in daN (1 daN = 1 Kg)		
Materiali:	6x45TZ	8x52TZ
Ø vite mm	4,5	5,0
Calcestruzzo C20/25	390	460
Calcestruzzo aerato autoclavato 3 N/mm <sup>2</sup>	60	63
Blocchetti di tufo 7,5 N/mm <sup>2</sup>	70	81
Muratura forata 1,5 N/mm <sup>2</sup>	79	86
Muratura piena 2,5 N/mm <sup>2</sup>	48	56
Blocchetti di calcestruzzo cavo alleggerito spessore 2 cm	53	63

\* Si consiglia di applicare un coefficiente di sicurezza pari a 5.

Code	Desc. Measure	Model
155TA10565	6x45TZ	Senza vite. Consigliata Ø 4,5 mm
155TA10570	8x52TZ	Senza vite. Consigliata Ø 5,0 mm
155TA10575	6x45TVZ	Con vite truciolate TSP+ zincata 4,5x40
155TA10580	8x52TVZ	Con vite truciolate TSP+ zincata 5,0x60

## Tassello universale in nylon 4 settori



### INDICAZIONI DI POSA

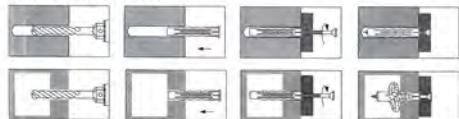

Adottare un adeguato coefficiente di sicurezza (4+5)

VALORI DI ESTRAZIONE		(1 daN = 1 Kg)		
Dim. vite/ Screw		6x35	8x50	10x60
Calcestruzzo Rc250*/Concrete		90	180	280
Mattone forato/Hollow brick		80	100	160
Mattone pieno/Solid brick		90	180	280

\* Rc 250-25N/mm<sup>2</sup>

- Tassello multiuso di nuova concezione per l'impiego su tutti i materiali edili.
- La sua particolare struttura ne rende possibile l'applicazione su superfici piene e vuote.
- Nelle superfici piene si ottiene una straordinaria tenuta per espansione forzata.
- Nelle superfici vuote si ottiene, invece, la speciale tenuta a nodo.
- È dotato di un robusto collarino per evitarne lo scivolamento nel foro.
- I quattro settori laterali permettono la massima tenuta su qualsiasi tipo di materiale.

Code	Desc.	Ø hole mm	Ø screw mm
155TA05150	6X35 UX	6	4,0
155TA05200	8X50 UX	8	4,5
155TA05250	10X60 UX	10	4,5-5,0

5

## Tassello universale in nylon 4 settori completo di vite



- Tassello in nylon completo di vite, avente le stesse caratteristiche come sopra, ma completo di vite truciolare testa piana svasata, taglio croce, zincata.

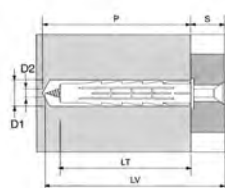

P = Profondità minima foro  
 S = spessore oggetto da fissare  
 LT = Lunghezza tassello  
 LV = Lunghezza vite  
 D1 = Diametro foro = Diametro punta  
 D2 = Diametro vite

Code	Description	Ø hole mm	Ø screw mm
155TA05300	6x35 UXV Tassello Nylon 4 sett. + Vite	6	3,5X45
155TA05350	8x50 UXV Tassello Nylon 4 sett. + Vite	8	4,5X60
155TA05400	10x60 UXV Tassello Nylon 4 sett. + Vite	10	5,0X70



## Tassello in nylon a quattro settori GX

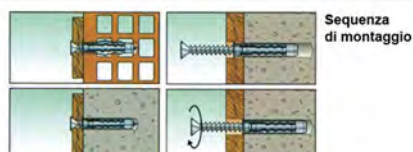

Sequenza di montaggio

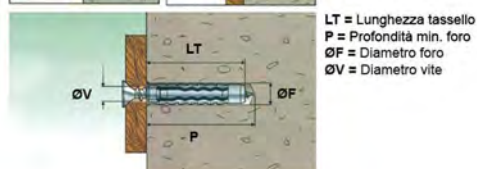

- Tassello ad espansione in nylon a 4 settori.
- Ideale per: serramenti, elettricisti, termoidraulica, carpenteria leggera.
- Adatto per tutti i tipi di materiale sia compatti che forati.
- Ideale per fissare: quadri, lampade, interruttori, guide per tende, porte, finestre, staffe, antenne.
- Vantaggi: ottima tenuta grazie all'espansione a 4 settori. Le alette impediscono al tassello di ruotare nel foro. Lo speciale collare flessibile ne permette il montaggio passante. La particolare forma del corpo permette l'inserimento di viti di ogni tipo, anche con filettatura metrica.
- Disponibile solo corpo espansore o completo di viti TPS o testa cilindrica.

Code	Desc.	Ø hole mm	Dowel length mm	Depth hole mm	Ø Vite consigliato mm
155TA08460	5X25GX	5	25	35	4,0
155TA08470	6X30GX	6	30	45	4,5
155TA08480	8X40GX	8	40	55	5,0
155TA08490	10x50GX	10	50	65	6,0
155TA08500	12X60GX	12	60	75	8,0
155TA08510	14x75GX	14	75	90	10,0

## Tassello in nylon a quattro settori GX



TASSELLO IN NYLON A QUATTRO SETTORI GX						
Valori di estrazione in daN (1 daN = 1 Kg)						
MATERIALI DI SUPPORTO	Ø 5	Ø 6	Ø 8	Ø 10	Ø 12	Ø 14
Calcestruzzo R250 (250 kg/cm <sup>2</sup> )	180	280	300	800	1200	2400
Mattoni pieni	27	27	36	71	82	91
Mattoni forati doppio UNI con intonaco	80	80	150	300	330	360
Cis cellulare	7	9	16	20	23	36

Code	Desc.	Ø hole mm	Dowel length mm	Depth hole mm	Spes. max fissabile mm	Screw Diam.	Imprint PZ	Type
155TA08550	5X25GXV	5	25	35	5	4X30	2	CON VITE TSP
155TA08560	6X30GXV	6	30	45	10	4,5X50	2	CON VITE TSP
155TA08570	8X40GXV	8	40	55	10	5X50	2	CON VITE TSP
155TA08580	10X50GXV	10	50	65	10	6X60	3	CON VITE TSP
155TA08600	6X30GXL	6	30	45	10	4,5X32	2	CON VITE TC-FL
155TA08610	8X40GXL	8	40	55	10	5X45	2	CON VITE TC-FL

## Kit secchiello fissaggio



- In pratico secchiello riutilizzabile.
- CONTENUTO:
- 300 pz. Tasselli a 4 settori GXV cod. 155TA08560
- 2 pz. Bits cod. 4430046622
- 1 pz. centrapunte cod. 4430055100

Code	Description
1550100630	Kit secchiello fissaggio



## Kit cassetta fissaggio



- In pratica cassetta riutilizzabile.
- CONTENUTO:
- 500 pz. Tasselli a 4 settori GXV cod. 155TA08560
- 1 pz. punta foratutto cod. 3260400300
- 2 pz. Bits cod. 4430046622
- 1 pz. centrapunte cod. 4430055100

Code	Description
1550100620	Kit cassetta fissaggio

5

## Tassello in nylon a quattro settori SX



SEQUENZA DI MONTAGGIO

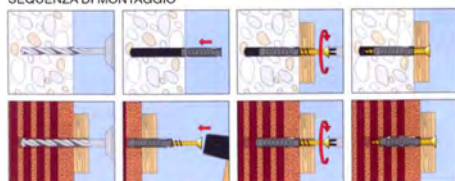

Si raccomanda un'accurata pulizia del foro prima dell'istallazione.

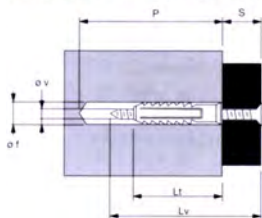

Code	Desc.	LT	Ø foro	P	ØV Da/a	Type
155TA07800	5X25 SX	25	5	35	3/4	SOLO CORPO ESPANSORE
155TA07810	6X30 SX	30	6	40	4/5	SOLO CORPO ESPANSORE
155TA07820	8X40 SX	40	8	50	4,5/6	SOLO CORPO ESPANSORE
155TA07830	10X50 SX	50	10	70	6/8	SOLO CORPO ESPANSORE
155TA07840	12X60 SX	60	12	80	8/10	SOLO CORPO ESPANSORE

## Tasselli con vite TSP



VALORI DI ESTRAZIONE IN daN VERIFICATI UTILIZZANDO VITI PER LEGNO (1 daN = 1 Kg)					
TASSELLO	Ø 5 mm.	Ø 6 mm.	Ø 8 mm.	Ø 10 mm.	Ø 12 mm.
Ø vite (mm.)	4	5	6	8	10
Calcestruzzo R 250 (250 Kg/cm <sup>2</sup> )	196	490	600	1120	1610
Mattone pieno	189	280	490	-	-
Doppio UNI con intonaco	84	105	210	-	-
Gas Beton >G4	56	56	105	210	315

Si consiglia l'adozione di un adeguato coefficiente di sicurezza secondo i casi.

Code	Desc.	LT	Ø foro	P	ØV X Lv	S	Imprint PZ
155TA07900	5X25 SXV	25	5	30	4X30	5	2
155TA07910	6X30 SXV	30	6	40	4,5X40	10	2
155TA07920	8X40 SXV	40	8	50	5X50	10	2
155TA07930	10X50 SXV	50	10	70	6X60	10	3

## Tasselli con vite a testa bombata



VALORI DI ESTRAZIONE IN daN VERIFICATI UTILIZZANDO VITI PER LEGNO (1 daN = 1 Kg)					
TASSELLO	Ø 5 mm.	Ø 6 mm.	Ø 8 mm.	Ø 10 mm.	Ø 12 mm.
Ø vite (mm.)	4	5	6	8	10
Calcestruzzo R 250 (250 Kg/cm <sup>2</sup> )	196	490	600	1120	1610
Mattone pieno	189	280	490	-	-
Doppio UNI con intonaco	84	105	210	-	-
Gas Beton >G4	56	56	105	210	315

Si consiglia l'adozione di un adeguato coefficiente di sicurezza secondo i casi.

Code	Desc.	LT	Ø foro	P	ØV X Lv	S	Imprint PZ
155TA07950	6X30 SXB	30	6	40	4,5X40	6	2
155TA07960	8X40 SXB	40	8	50	5X50	5	2

## Tasselli in materiale bicomponente Duopower



- Tasselli in materiale bicomponente, studiati appositamente per fissaggi universali, sia di tipo passante sia non, idonei per fissaggi su ogni tipo di superficie, forata o piena, che assicurano una portata più alta dei classici tasselli in nylon ed una semplicità di posa ineguagliabile.
- Indicati per fissaggi sicuri di: mensole, ripiani, armadietti, quadri, tendaggi, binari per tende, raccordi idraulici e per riscaldamento, accessori per bagni, lampadari, mobili pensili, ecc.
- I vantaggi dati dalla costruzione bicomponente e dalla speciale forma sono: valori di carico più elevati rispetto ai normali tasselli in nylon, percezione migliore da parte dell'operatore della buona riuscita del serraggio, ridotta lunghezza del tassello e relativa ridotta profondità di foratura, il collare sottile impedisce al tassello di scivolare in profondità e non fa spessore, le alette anti rotazione ravvicinate impediscono al tassello di ruotare durante l'avvitamento.
- Utilizzabili su calcestruzzo, mattoni pieni e forati, blocchi in calcestruzzo alleggerito, cartongesso, solai cavi, pietra naturale, truciolare, gesso.
- Disponibili nelle versioni con vite autofilettante TSP impronta Pozidriv e senza vite.

5

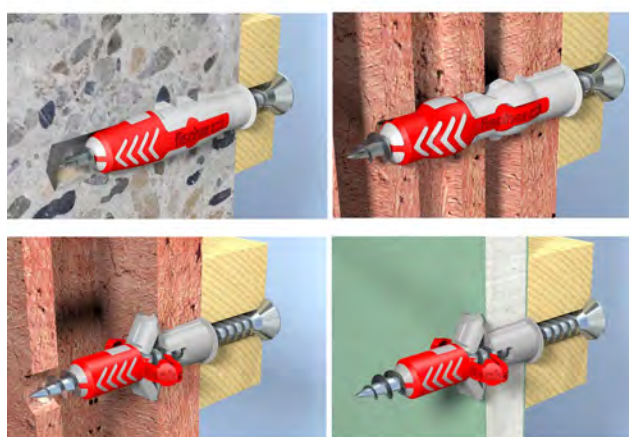

### DUOPOWER

Carichi raccomandati massimi<sup>1)</sup> per un ancorante singolo

I carichi forniti sono validi per **viti legno** secondo DIN 571 con diametro specificato

<sup>1)</sup> Include il fattore di sicurezza 7.

<sup>2)</sup> Valido per carico di trazione, taglio e oblique con qualsiasi inclinazione.

<sup>3)</sup> Vite truciolare 6 mm.

Tipo	DUOPOWER 5 x 25	DUOPOWER 6 x 30	DUOPOWER 8 x 40	DUOPOWER 10 x 50
Diametro vite Ø [mm]	4	5	6	8
Distanza dal bordo min in calcestruzzo c <sub>min</sub> [mm]	30	35	50	65
<b>Carichi raccomandati nel rispettivo materiale di base F<sub>racc</sub><sup>2)</sup></b>				
Calcestruzzo ≥ C20/25 [kN]	0,30	0,80	0,90	2,00
Mattoni pieni in laterizio ≥ Mz 12 [kN]	0,25	0,40	0,45	1,00
Mattoni pieni in silicato di calcio ≥ KS 12 [kN]	0,42	0,80	0,90	1,85
Mattoni semipieni (perforato verticalmente) in laterizio ≥ Hz 12 (ρ ≥ 0,9 kg/dm <sup>3</sup> ) [kN]	0,10	0,15	0,20	0,25
Mattoni semipieni (perforato verticalmente) in silicato di calcio ≥ KSL 12 (ρ ≥ 1,6 kg/dm <sup>3</sup> ) [kN]	0,27	0,50	0,50	0,60
Mattoni semipieni (Doppio UNI 19) in laterizio [kN]	0,15	0,16	0,20	0,20
Mattoni forati (perforato orizzontalmente - Typ FB) in laterizio [kN]	0,10	0,10	0,12	0,16
Blocco pieno in gesso per partizioni interne ρ ≥ 0,9 kg/dm <sup>3</sup> [kN]	0,06	0,15	0,20	0,27
Calcestruzzo aerato autoclavato (cellulare) ≥ PB2, PP2 (G2) [kN]	0,05	0,06	0,08	0,15
Calcestruzzo aerato autoclavato (cellulare) ≥ PB4, PP2 (G4) [kN]	0,20	0,30	0,30	0,45
Lastra di cartongesso singola 12,5 mm [kN]	0,09	0,12	0,15	0,15 <sup>3)</sup>
Lastra di cartongesso doppia 2 x 12,5 mm [kN]	0,10	0,12	0,17	0,23
Lastra di gessofibra 12,5 mm [kN]	0,17	0,30	0,30	0,35 <sup>3)</sup>

Code	Desc.	Ø foro	Depth hole mm	Spessore pannello min mm	Dowel length mm	Ø viti truciolare mm	Imprint PZ	Versione
155TA11200	DP5	5	35	12,5	25	3 - 4	-	senza vite
155TA11210	DP6	6	40	12,5	30	4 - 5	-	senza vite
155TA11220	DP8	8	50	12,5	40	4,5 - 6	-	senza vite
155TA11230	DP10	10	70	12,5	50	6 - 8	-	senza vite
155TA11240	DP12	12	70	-	60	8 - 10	-	senza vite
155TA11250	DPV5	5	35	12,5	25	3 - 4	2	con vite
155TA11260	DPV6	6	40	12,5	30	4 - 5	2	con vite
155TA11270	DPV8	8	50	12,5	40	4,5 - 6	2	con vite
155TA11280	DPV10	10	70	12,5	50	6 - 8	3	con vite

## Tassello per supporti vuoti

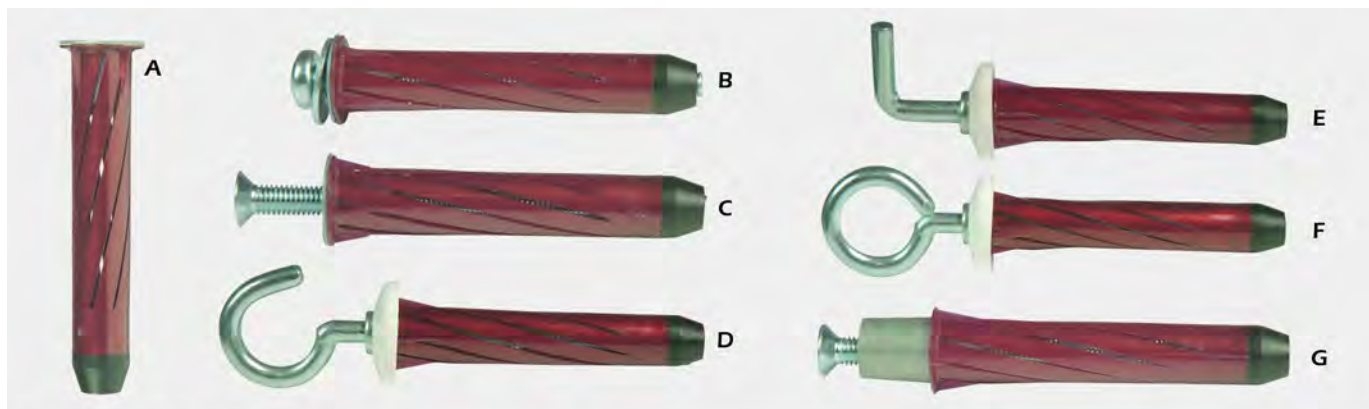

### SEQUENZA DI MONTAGGIO

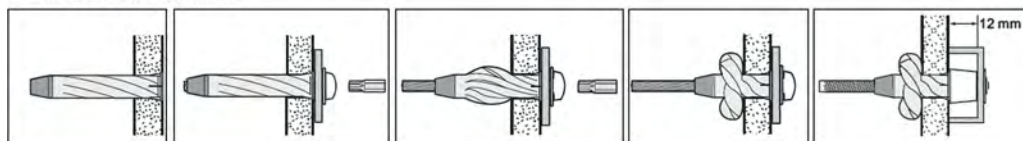

VALORI DI ESTRAZIONE 1 KN= 100 Kg							
Valori di carico in tensione = 0,38 KN	155 TA 09600 155 TA 09610 155 TA 09620 155 TA 09630 155 TA 09640 155 TA 09680	Valori di carico in tensione = 0,20 KN	155 TA 09650 155 TA 09660 155 TA 09670	Valori di carico in tensione = 0,70 KN	155 TA 09700 155 TA 09710 155 TA 09720 155 TA 09730 155 TA 09770	Valori di carico in tensione = 0,20 KN	155 TA 09740 155 TA 09750 155 TA 09760
Valori di carico in taglio = 0,50 KN	155 TA 09600 155 TA 09610 155 TA 09620 155 TA 09630 155 TA 09640 155 TA 09680	Valori di carico in taglio = 0,35 KN	155 TA 09650 155 TA 09660 155 TA 09670	Valori di carico in taglio = 0,85 KN	155 TA 09700 155 TA 09710 155 TA 09720 155 TA 09730 155 TA 09770	Valori di carico in taglio = 0,35 KN	155 TA 09740 155 TA 09750 155 TA 09760

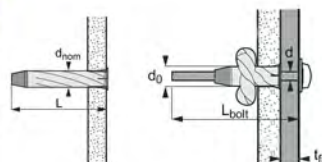

Code	Desc.	Ø Tassello (d nom)	Lung. tas. (L)	Ø vite (d)	Screw leng. (L bolt)	Spess. fis. (t fix)	Ø foro (d 0)	Model	Color	Photo	Appl. Torx
155TA09600	10x46	10	46	M5	-	-	10	-	Blu	A	-
155TA09610	10x46 TC55	10	46	M5	55	15	10	Vite TC	Blu	B	T30
155TA09620	10x46 TC80	10	46	M5	80	45	10	Vite TC	Blu	B	T30
155TA09630	10x46 TPS65	10	46	M5	65	25	10	Vite TPS	Blu	C	T30
155TA09640	10x46 TPS80	10	46	M5	80	40	10	Vite TPS	Blu	C	T30
155TA09650	10x46 OA	10	46	M5	55	-	10	Occhiolo aperto	Blu	D	-
155TA09660	10x46 G	10	46	M5	55	-	10	Gancio	Blu	E	-
155TA09670	10x46 OC	10	46	M5	55	-	10	Occhiolo chiuso	Blu	F	-
155TA09680	10x46 S	10	46	M5	65	12	10	Con spessore	Blu	G	T30
155TA09690	10x57	10	57	M5	-	-	10	-	Rosso	A	-
155TA09700	10x57 TC65	10	57	M5	65	12	10	Vite TC	Rosso	B	T30
155TA09710	10x57 TC90	10	57	M5	90	38	10	Vite TC	Rosso	B	T30
155TA09730	10x57 TPS90	10	57	M5	90	38	10	Vite TPS	Rosso	C	T30
155TA09740	10x57 OA	10	57	M5	55	-	10	Occhiolo aperto	Rosso	D	-
155TA09750	10x57 G	10	57	M5	55	-	10	Gancio	Rosso	E	-
155TA09760	10x57 OC	10	57	M5	55	-	10	Occhiolo chiuso	Rosso	F	-
155TA09770	10x57 S	10	57	M5	75	12	10	Con spessore	Rosso	G	T30



## Nylon insert complete with accessories

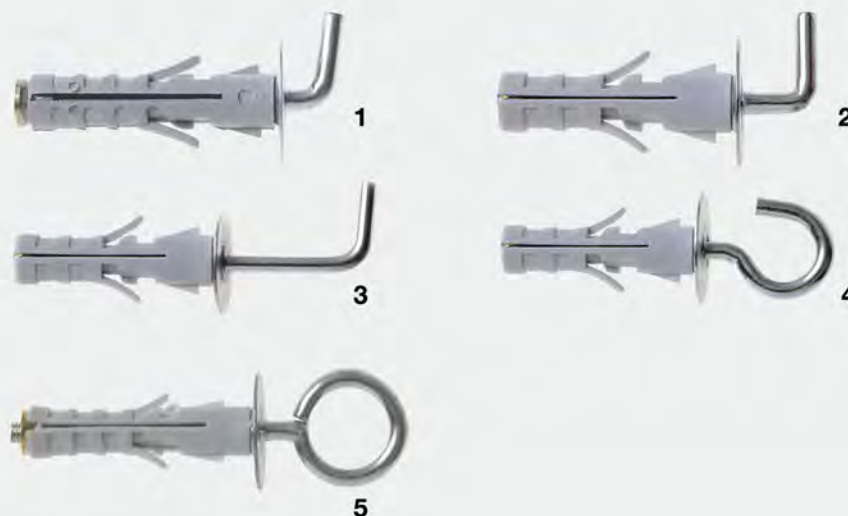

5

**SEQUENZA DI MONTAGGIO**



**MATERIALE**

Corpo in poliammide PA 6.  
Accessori in acciaio trattato con zincatura galvanica.

**IMPORTANTE**

Applicare un coefficiente di sicurezza adeguato ad ogni singolo caso.

TASSELLI IN NYLON CON PITONERIA		
VALORI DI ESTRAZIONE IN daN [1 daN=1kg]		
CALCESTRUZZO R250 (250 Kg/cm <sup>2</sup> )	ø.9	ø.12
TASSELLO COD. 155 TA 00900 - 01300	70	150
TASSELLO COD. 155 TA 00950 - 01350	40	80
TASSELLO COD. 155 TA 01000 - 01400	30	50
TASSELLO COD. 155 TA 01050 - 01450	35	65
TASSELLO COD. 155 TA 01100 - 01500	35	65

- Insert of great versatility, available in 2 diameters and with a vast range of accessories to satisfy any fixing need in both diy and professional activity fields.
- Indispensable for applying shelving and brackets, small carpentry jobs, generic attachments, various installations etc.
- Special expansion system with metallic recall cone to overcome any hollows present in the base material.
- Expansion can occur over almost 3/4 of the length of the insert body.
- Anti-rotation wings.
- Improved grip achieved through very pronounced external notches.
- Each model comes with an extra-wide washer for improved distribution of pressure and to protect the support walls.

Code	Desc. ØxL body	Installed accessory	Photo
155TA00900	9x38/GC	Short hook overhang 4 mm	1
155TA00950	9x38/GM	Medium hook overhang 10 mm	2
155TA01350	12x45/GM	Medium hook overhang 10 mm	2
155TA01000	9x38/GL	Long hook overhang 17 mm	3
155TA01050	9x38/OA	Open circular hook, 9mm	4
155TA01100	9x38/OC	Closed circ. ring, int.Ø 13MM	5



## Tassello standard in nylon corpo prolungato completo di vite impronta croce



Impronta **POZIDRIV**

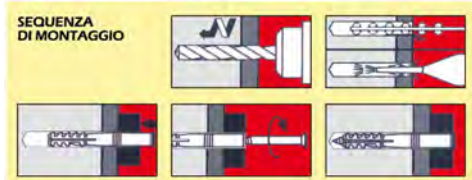

**IMPORTANTE**

Applicare un coefficiente di sicurezza adeguato ad ogni singolo caso

TASSELLI STANDARD IN NYLON CORPO PROLUNGATO			
Valori di estrazione in daN (1 daN = 1 Kg)			
MATERIALI DI SUPPORTO	Ø 6	Ø 8	Ø 10
Calcestruzzo R250 (250 kg/cm <sup>2</sup> )	200	340	420
Mattoni pieni	150	300	350

- Tassello in nylon per fissaggi leggeri completo di vite autofilettante con testa svasata piana, impronta a croce pozidriv.
- Adatto per fissaggi passanti attraverso grossi spessori quali listelli in legno, profili e telai di infissi, ecc.
- La forma prolungata permette di superare le superfici non portanti quali intonaci e rivestimenti.
- Disponibile in varie lunghezze per l'esatto accoppiamento con lo spessore dell'oggetto da fissare.

Code	Desc. Ø x L	Ø hole mm	Ø screw mm	Imprint size	Type
155TA02100	6X60 CPV	6	4X60	PZ2	Imp. Pozidriv
155TA02150	8X80 CPV	8	6X85	PZ3	Imp. Pozidriv
155TA02200	8X100 CPV	8	6X105	PZ3	Imp. Pozidriv
155TA02300	10X80 CPV	10	7X90	PZ3	Imp. Pozidriv
155TA02350	10X100 CPV	10	7X105	PZ3	Imp. Pozidriv
155TA02450	10X135 CPV	10	7X140	PZ3	Imp. Pozidriv
155TA02500	10X160 CPV	10	7X165	PZ3	Imp. Pozidriv

## Tassello in nylon corpo prolungato ed espansione maggiorata

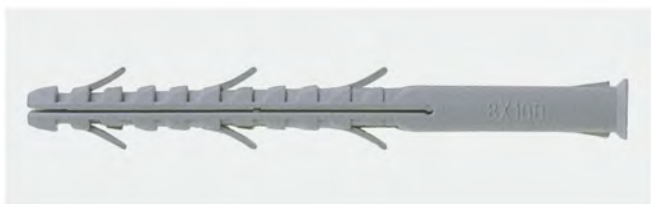

- Tassello adatto per fissaggi leggeri passanti attraverso grossi spessori quali listelli in legno, profili e telai di infissi, ecc.
- Necessario dove sia opportuno sfruttare al massimo la portata dei materiali di supporto.
- La geometria interna e la zona di espansione prolungata distribuiscono su una zona maggiore la pressione dovuta all'espansione del tassello stesso.
- Dotato di sei alette antirrotazione e collare svasato contro lo scivolamento in profondità e per il posizionamento a filo dell'oggetto da fissare della testa della vite.
- Ottimo per materiali poco compatti e di scarsa resistenza e per pareti forate.

Code	Desc. Ø x L	Ø hole mm	Ø Vite consigliato mm
155TA02550	8X80 EP	8	4,5-6
155TA02600	8X100 EP	8	4,5-6
155TA02650	8X120 EP	8	4,5-6
155TA02700	10X80 EP	10	7
155TA02750	10X100 EP	10	7
155TA02850	10X135 EP	10	7
155TA02900	10X160 EP	10	7

## Tassello in nylon corpo prolungato ed espansione maggiorata completo di vite impronta croce e torx



Impronta POZIDRIV

Impronta TORX

SEQUENZA DI MONTAGGIO

**IMPORTANTE**

Applicare un coefficiente di sicurezza adeguato ad ogni singolo caso

TASSELLO IN NYLON CORPO PROLUNGATO ED ESPANSIONE MAGGIORATA		
VALORI DI ESTRAZIONE IN daN (1 daN= 1kg)		
MATERIALI DI SUPPORTO	ø.8	ø.10
Calcestruzzo R250 (250 Kg/cm <sup>2</sup> )	400	460
Mattoni pieni	380	400
Mattoni forati	190	300

- Tassello in nylon per fissaggi leggeri, stesse caratteristiche del precedente, ma già completo di vite autofilettante zincata con testa svasata piana, impronta a croce pozidriv o torx.

Code	Desc. Ø x L	Ø hole mm	Screw dim. mm	Imprint size	Type
155TA02950	8X80 EPV	8	5,5X85	PZ3	Imp. Pozidriv
155TA03000	8X100 EPV	8	5,5X105	PZ3	Imp. Pozidriv
155TA03050	8X120 EPV	8	5,5X125	PZ3	Imp. Pozidriv
155TA03100	10X80 EPV	10	7X85	PZ3	Imp. Pozidriv
155TA03150	10X100 EPV	10	7X105	PZ3	Imp. Pozidriv
155TA03250	10X135 EPV	10	7X140	PZ3	Imp. Pozidriv
155TA03300	10X160 EPV	10	7X165	PZ3	Imp. Pozidriv
155TA03310	10X200 EPV	10	7X205	PZ3	Imp. Pozidriv
155TA08750	8X80 EPT	8	5,5X85	T30	Imp. Torx
155TA08780	8X100 EPT	8	5,5X105	T30	Imp. Torx
155TA08790	8X120 EPT	8	5,5X125	T30	Imp. Torx
155TA08800	10X80 EPT	10	7X85	T40	Imp. Torx
155TA08810	10X100 EPT	10	7X105	T40	Imp. Torx
155TA08820	10X135 EPT	10	7X140	T40	Imp. Torx
155TA08840	10X200 EPT	10	7X205	T40	Imp. Torx
155TA08830	10X160 EPT	10	7X165	T40	Imp. Torx

5

## Tassello prolungato universale in nylon ad espansione sfalsata

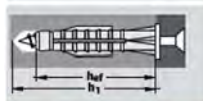
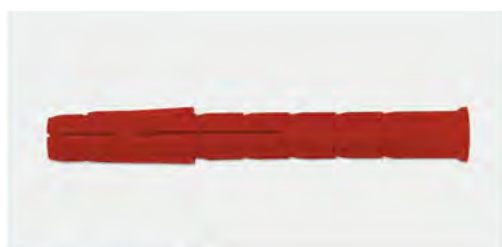

VALORI DI ESTRAZIONE IN daN (1 daN=1kg)				
MATERIALI DI SUPPORTO	ø.6 mm	ø.8 mm	ø.10 mm	ø.12 mm
Calcestruzzo R250 (250 Kg/cm <sup>2</sup> )	150	200	250	300
Mattoni pieno	100	120	140	160
Mattoni forato	25	35	60	70

- Tassello universale innovativo in nylon, per fissaggi passanti, funzionamento ad espansione.
- Con due zone diverse di espansione ed indipendenti che assicurano sempre una presa ottimale anche su supporti non compatti, come il calcestruzzo cellulare.
- Bordo che impedisce lo scivolamento in profondità nel foro.
- Le alette mobili in fondo al tassello ne evitano la rotazione, e conferiscono una maggiore tenuta.
- Idoneo su mattoni forati e pieni, calcestruzzo cellulare, muratura, ecc...
- Ideali per il fissaggio di telai di porte e finestre, sottostrutture in legno, armadietti pensili, ecc..
- Settore di utilizzo: serramenti, carpenteria, impianti elettrici e termoidraulici.
- Da utilizzarsi con viti autofilettanti per truciolare o tirafondi. Montare sempre possibilmente il diametro maggiore di vite consigliato.

Code	Desc. Ø x L	Ø hole mm	Ø Vite consigliato mm	Profondità foratura (h1) mm	Dowel length hef mm
155TA09200	6X70 mm PSD-SL	6	4,5-5,0	80	70
155TA09210	8X90 mm PSD-SL	8	5,0-6,0	100	90
155TA09220	10x90 mm PSD-SL	10	6,0-8,0	100	90
155TA09230	12x90 mm PSD-SL	12	10	100	90

## Tassello prolungato universale in nylon MV-SK



### VALORI DI ESTRAZIONE IN daN (1 daN≅1kg)

MATERIALI DI SUPPORTO	ø.6 mm	ø.8 mm	ø.10 mm
Calcestruzzo R250 (250 Kg/cm <sup>2</sup> )	35	80	120
Mattone pieno	35	80	120
Mattone forato	20	30	30

Code	Desc. Ø X L mm	Ø hole mm	Screw dim. mm	Lung. Foro h1 mm	Useful length fixing hef mm	Spessore fissaggio tfix mm	Imprint Torx
155TA09250	6X50 MV-SK	6	4,0X55	60	35	15	T20
155TA09260	6X70 MV-SK	6	4,0X75	80	35	35	T20
155TA09270	8X60 MV-SK	8	5,5X65	70	50	10	T25
155TA09280	8X80 MV-SK	8	5,5X85	90	50	30	T25
155TA09290	8X100 MV-SK	8	5,5X105	110	50	50	T25
155TA09320	10X135 MV-SK	10	7,0X140	145	60	75	T40
155TA09330	10X160 MV-SK	10	7,0X170	175	60	100	T40

## Tassello prolungato universale con punta in metallo

**VALORI DI ESTRAZIONE IN daN (1 daN ≈ 1kg)**

MATERIALI DI SUPPORTO	ø.6 mm	ø.8 mm	ø.10 mm
Calcestruzzo R250 (250 Kg/cm <sup>2</sup> )	30	80	120
Mattone pieno	30	80	120
Mattone forato	30	40	60

- Tassello universale premontato in nylon, con funzionamento a nodo e ad espansione. Per fissaggi passanti. Svasatura in testa che impedisce lo scivolamento nel foro. Alette antirotazione.
- Disponibile con vite zincata bianca a testa svasata (impronta Torx) o esagonale.
- La punta di metallo favorisce l'espansione ed il fissaggio in modo ottimale.
- La sua struttura gli permette di fare presa su molti tipi di materiali come: calcestruzzo, mattone pieno e forato, blocchi cavi di calcestruzzo, pannelli di cartongesso, calcestruzzo poroso.
- Possibilità' di essere piantato con martello (senza fare prima il foro), su materiali porosi come cartongesso, truciolare, legno tenero, ed anche mattoni forati.
- Adatto per il fissaggio di travi in legno, sottostrutture in legno, armadietti pensili, telai di porte e finestre, costruzioni in metallo, guide in metallo, ecc.
- Settore di utilizzo: serramenti, carpenteria, impiantisti elettrici e termoidraulici.

Code	Desc. Ø X L mm	Ø hole mm	Screw ØxL mm	Lung. Foro h1 mm	Useful length fixing hef mm	Spessore fissaggio tfix mm	Tipo testa	Appl. Torx
155TA09350	6X50 VLF-S1	6	4,5X55	60	35	15	SVASATA	T20
155TA09360	6X70 VLF-S1	6	4,5X70	80	35	35	SVASATA	T20
155TA09370	8X60 VLF-S1	8	6,0X60	70	50	10	SVASATA	T25
155TA09380	8X80 VLF-S1	8	6,0X80	90	50/(70)	30/(10)	SVASATA	T25
155TA09390	8X100 VLF-S1	8	6,0X100	110	50/(70)	50/(30)	SVASATA	T25
155TA09400	8X120 VLF-S1	8	6,0X120	130	50/(70)	70/(50)	SVASATA	T25
155TA09410	8X140 VLF-S1	8	6,0X140	150	50/(70)	90/(70)	SVASATA	T25
155TA09420	10X100 VLF-S1	10	7,0X100	110	60/(80)	40/(20)	SVASATA	T40
155TA09430	10X120 VLF-S1	10	7,0X120	130	60/(80)	60/(40)	SVASATA	T40
155TA09440	10X140 VLF-S1	10	7,0X140	150	60/(80)	80/(60)	SVASATA	T40
155TA09450	10X160 VLF-S1	10	7,0X160	170	60/(80)	100/(80)	SVASATA	T40
155TA09460	10X100 VLF-S2	10	7,0X100	110	60/(80)	40/(20)	ESAGONALE	E13
155TA09470	10X120 VLF-S2	10	7,0X120	130	60/(80)	60/(40)	ESAGONALE	E13
155TA09480	10X140 VLF-S2	10	7,0X140	150	60/(80)	80/(60)	ESAGONALE	E13
155TA09490	10X160 VLF-S2	10	7,0X160	170	60/(80)	100/(80)	ESAGONALE	E13

## Tassello prolungato a quattro settori GXL - Ideale per cappotti



SEQUENZA DI MONTAGGIO

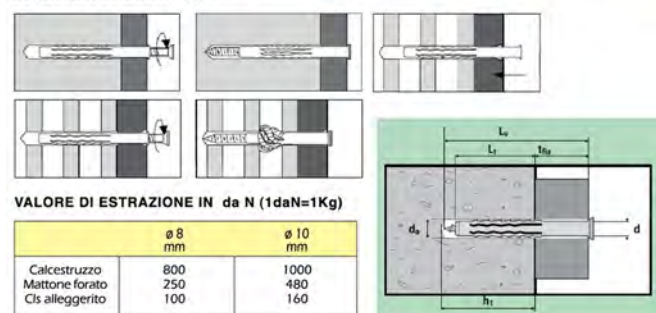

VALORE DI ESTRAZIONE IN da N (1daN=1Kg)

	ø 8 mm	ø 10 mm
Calcestruzzo	800	1000
Mattone forato	250	480
Cis alleggerito	100	160

- Tassello in nylon a corpo prolungato ed espansione a quattro settori per l'ancoraggio sicuro su ogni tipo di muratura, piena e forata. Lunghezze massime studiate per fissaggi passanti attraverso le cappottature ed i rivestimenti isolanti delle facciate e delle pareti in genere.
- La zona di espansione permette di distribuire in modo uniforme la pressione sulle pareti dei fori nelle superfici compatte, mentre in quelle forate il fissaggio avviene per contrasto con annodamento del tassello.
- Fissaggio passante degli oggetti, forma del tassello antirotazione, bordino superiore e facilità di serraggio anche tramite utensili manuali.
- Fornito senza vite, da acquistare a parte in base allo spessore dell'oggetto fissato.

Code	Desc.	Ø hole mm	Lung. tass. mm	Ø vite utilizzabile mm
155TA10410	8x80/GXL	8	80	5,5
155TA10415	8x100/GXL	8	100	5,5
155TA10420	8x120/GXL	8	120	5,5
155TA10425	8x140/GXL	8	140	5,5
155TA10430	8x170/GXL	8	170	5,5
155TA10435	8x200/GXL	8	200	5,5
155TA10440	10x80/GXL	10	80	7
155TA10445	10x100/GXL	10	100	7
155TA10450	10x120/GXL	10	120	7
155TA10455	10x140/GXL	10	140	7
155TA10460	10x160/GXL	10	160	7
155TA10465	10x200/GXL	10	200	7
155TA10470	10x240/GXL	10	240	7
155TA10475	10x260/GXL	10	260	7

## Viti autofilettanti TSP Torx per tasselli in nylon



- Viti in acciaio zincato, testa svasata piana ed impronta Torx specifiche per l'utilizzo in abbinamento a tasselli in espansione in nylon di ogni tipo.
- Corpo in acciaio a fusto maggiorato per massimizzare l'espansione dei tasselli, testa svasata piana per fissaggi a scomparsa, impronta Torx con profondità maggiorata per la maggiore stabilità e sicurezza nel serraggio.
- Filettatura studiata appositamente per la massima tenuta all'estrazione nel corpo in nylon degli ancoranti.

Code	Desc. Ø X L mm	Ø testa mm	Imprint Torx
155TA10480	5,5x85/VPT	12	T30
155TA10485	5,5x105/VPT	12	T30
155TA10490	5,5x125/VPT	12	T30
155TA10495	5,5x145/VPT	12	T30
155TA10500	5,5x175/VPT	12	T30
155TA10505	5,5x200/VPT	12	T30
155TA10510	7,0x85/VPT	14	T40
155TA10515	7,0x105/VPT	14	T40
155TA10520	7,0x125/VPT	14	T40
155TA10525	7,0x145/VPT	14	T40
155TA10530	7,0x165/VPT	14	T40
155TA10535	7,0x205/VPT	14	T40
155TA10540	7,0x245/VPT	14	T40
155TA10545	7,0x265/VPT	14	T40



## Viti autofilettanti Inox A4 TSP Torx per tasselli in nylon



- Viti in acciaio inox A4, testa svasata piana ed impronta Torx specifiche per l'utilizzo in abbinamento a tasselli a espansione in nylon di ogni tipo.
- Corpo in acciaio a fusto maggiorato per massimizzare l'espansione dei tasselli, testa svasata piana per fissaggi a scomparsa, impronta Torx con profondità maggiorata per la maggiore stabilità e sicurezza nel serraggio.
- Filettatura studiata appositamente per la massima tenuta all'estrazione nel corpo in nylon degli ancoranti.

Code	Desc. Ø X L mm	Ø testa mm	Imprint <i>Torx</i>
155A201400	7X85VPX	14	T40
155A201450	7X105VPX	14	T40
155A201500	7X120VPX	14	T40
155A201550	7X140VPX	14	T40
155A201600	7X165VPX	14	T40

## Tassello in nylon prolungato a quattro settori MXL

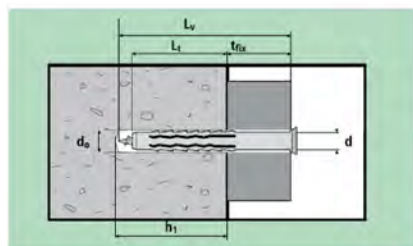

5

SEQUENZA DI MONTAGGIO



VALORE DI ESTRAZIONE IN da N (1daN=1Kg)

	ø 8 mm	ø 10 mm
Calcestruzzo	800	1000
Mattone forato	250	480
Cis alleggerito	100	160

- Tassello universale ad espansione, per fissaggi passanti.
- Ideale per: serramenti, carpenteria leggera, impianti temoidraulici ed elettrici, montatori, edilizia.
- Applicazioni universali per tutte le tipologie di muratura piena e forata, tra cui: pietra, calcestruzzo, laterizi pieni, semipieni, forati, gasbeton.
- Ideale per fissare infissi, porte, ringhiere, corrimano, cancelli, strutture in legno, pensili.
- Il suo corpo espandente a quattro settori, gli permette di adattarsi su tutte le tipologie di muratura massimizzando la capacita' di tenuta.
- Espansione ad annodamento su supporti forati.
- Il collare svasato impedisce al tassello di entrare nel foro, le alette ne evitano la rotazione durante l'avvitamento.
- La parte iniziale del tassello presenta un invito conico che favorisce il corretto inserimento della vite.
- Fornito con apposita vite ad impronta torx che ne ottimizza il serraggio.

Code	Desc. ø x Lt	Ø foro (do) mm	Vite (dxLv) mm	Lung. Foro h1 mm	Spe. Fissabile (Tfix) mm	Imprint Torx
155TA10250	8X80 MXL	8	6X85	70	10	T30
155TA10260	8X100 MXL	8	6X105	70	30	T30
155TA10270	8X120 MXL	8	6X125	70	50	T30
155TA10300	10X80 MXL	10	7X85	70	10	T40
155TA10305	10X100 MXL	10	7X105	70	30	T40
155TA10310	10X120 MXL	10	7X120	70	50	T40
155TA10315	10X140 MXL	10	7X140	70	70	T40
155TA10320	10X160 MXL	10	7X165	70	90	T40

## Tassello in nylon FUR-T completo di vite



### SEQUENZA DI MONTAGGIO



### Valori di estrazione in daN (1 daN = 1 Kg)

TASSELLO	FUR8	FUR10
Calcestruzzo R250	810	1000
Mattone pieno	500	450
Doppio UNI con Intonaco	90	260

Code	Desc.	Ø hole mm	Spes. max fissabile mm	Imprint Torx
155TA07300	8X80/FUR	8	10	T30
155TA07350	8X100/FUR	8	30	T30
155TA07400	8X120/FUR	8	50	T30
155TA07450	10X80/FUR	10	10	T40
155TA07500	10X100/FUR	10	30	T40
155TA07550	10X115/FUR	10	45	T40
155TA07600	10X135/FUR	10	65	T40
155TA07650	10X160/FUR	10	90	T40
155TA07700	10X185/FUR	10	115	T40
155TA07750	10X200/FUR	10	130	T40
155TA07780	10X230/FUR	10	160	T40

5

## Tassello per fissaggio di serramenti ed infissi



### SEQUENZA DI MONTAGGIO



### IMPORTANTE

Applicare un coefficiente di sicurezza adeguato ad ogni singolo caso

VALORI DI ESTRAZIONE IN daN (1 daN=1kg)		
MATERIALI DI SUPPORTO	Ø.8	Ø.10
Calcestruzzo R250 (250 Kg/cm <sup>2</sup> )	300	560
Mattoni pieni	300	550
Mattoni forati	100	140

- Tassello in poliammide studiato appositamente per il fissaggio passante di telai, porte e finestre in legno, alluminio e PVC.
- Disponibile in più lunghezze e dotato di vite a testa svasata piana zincata, con impronta a croce Pozidriv e foro centrale per l'inserimento degli appositi tappi di finitura in plastica.
- Espansione tramite richiamo dell'apposito cono finale. Adatto per pareti in calcestruzzo, pietra naturale, murature piene e forate.
- Dotato di alette laterali anti rotazione.
- Il materiale con cui è costruito elimina ogni possibilità di corrosione e di creazione di eventuali ponti termici.
- Tappi di finitura colore bianco già compresi.

Code	Desc. Ø x L	Ø hole mm	Spes. max fissabile mm
155TA04700	8X75 NI	8	25
155TA04710	8X100 NI	8	50
155TA04720	8X120 NI	8	70
155TA04730	8X140 NI	8	90
155TA04740	10X75 NI	10	15
155TA04750	10X100 NI	10	40
155TA04760	10X120 NI	10	60
155TA04770	10X140 NI	10	80
155TA04780	10X1605 NI	10	100

## Tassello in nylon fissaggio a percussione



- Tassello per fissaggi leggeri a percussione indicato per applicazioni rapide e ripetitive
- Notevoli economie di tempo nel fissaggio passante di sottostrutture, profili di infissi, piccola carpenteria di supporto, canaline portacavi, lattoneria, ecc
- La forma particolare e la vite a chiodo ne permettono la posa con pochi colpi di martello
- Vite con impronta a croce per consentire un facile smontaggio con i normali utensili da avvitamento
- Disponibili con collare piatto o svasato per l'impiego su elementi sottili e leggeri o per il fissaggio a filo dell'oggetto
- Indicati per l'uso su materiali compatti quali: calcestruzzo, mattoni pieni, pietra naturale
- Già forniti con vite premontata

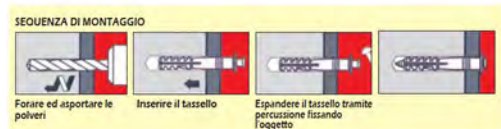

VALORI DI ESTRAZIONE IN daN (1 daN ≈ 1kg)			
MATERIALI DI SUPPORTO	Ø 5	Ø 6	Ø 8
Calcestruzzo R250 (250 Kg/cm <sup>2</sup> )	100	140	200
Mattoni pieni	100	120	170

Code	Desc. Ø x L	Tipo collare	Ø hole mm	Spes. max fissabile mm
155TA03650	5x25 P	Piatto	5	1
155TA03750	6x35 P	Piatto	6	5
155TA03800	6x45 P	Piatto	6	15
155TA03850	6x55 P	Piatto	6	25
155TA03950	8x57 P	Piatto	8	12
155TA04050	8x100 P	Piatto	8	60
155TA04100	5x30 PS	Svasato	5	5
155TA04150	5x45 PS	Svasato	5	15
155TA04200	6x40 PS	Svasato	6	10
155TA04250	6x55 PS	Svasato	6	25
155TA04300	6x70 PS	Svasato	6	40
155TA04350	8x57 PS	Svasato	8	12
155TA04400	8x75 PS	Svasato	8	30
155TA04450	8x100 PS	Svasato	8	60

## Tassello in nylon a percussione con vite in acciaio zincata bianca



- Tassello speciale per pareti forate e cartongesso.
- Eccezionale espansione da appena 5 mm sotto testa.
- Dotato di vite a chiodo zincata.
- Corpo del tassello in nylon colore bianco con collare Ø 13mm.
- Estrema facilità e velocità d'impiego.
- Ideale per il fissaggio leggero di canaline, profilature, battiscopa, listelli, ecc.

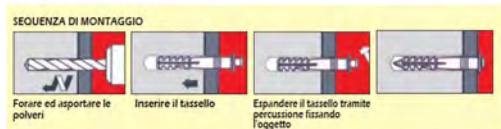

VALORI DI ESTRAZIONE (1 daN = 1 Kg)	
MATERIALE DI SUPPORTO	Ø 6
Calcestruzzo R250 (250 Kg/cm <sup>2</sup> )	130
Mattoni pieni	120

**IMPORTANTE**  
Applicare un coefficiente di sicurezza adeguato ad ogni singolo caso

Code	Desc.	Ø hole mm	Spess. fissabile mm. (s)
155TA04650	6X30 CZ	6	5
155TA04660	6X40 CZ	6	10
155TA04670	6X50 CZ	6	20
155TA04680	6X60 CZ	6	30

5

## Tassello in nylon a percussione con vite in rame



- Tassello speciale per lattoneria con bordo piatto  $\varnothing$  13 mm e vite a chiodo in rame, testa svasata piana con impronta a croce pozidriv
- Per fissaggi leggeri di grondaie, scossaline e lavori vari di lattoneria
- Corpo del tassello colore testa di moro
- Estrema facilità e velocità d'uso

### SEQUENZA DI MONTAGGIO



Forare ed asportare le polveri

Inserire il tassello

Espandere il tassello tramite percussione fissando l'oggetto

### Dati tecnici dei tasselli in nylon a percussione con vite in rame

**IMPORTANTE**  
Applicare un coefficiente di sicurezza adeguato ad ogni singolo caso

VALORI DI ESTRAZIONE IN daN [1 daN=1 kg]	
<b>MATERIALI DI SUPPORTO</b>	$\varnothing$ 6
Calcestruzzo R250 [250 Kg/cm <sup>2</sup> ]	130
Mattoni pieni	120

Code	Desc. $\varnothing \times L$	$\varnothing$ hole mm	Spes. max fissabile mm
155TA04630	6X50 CU	6	20

5

## Tassello in nylon testa di moro a percussione con vite nera



- Tassello speciale per lattoneria con collare bombato  $\varnothing$  13 mm. Vite in acciaio brunito colore nero.
- Per fissaggi leggeri di grondaie, scossaline e lavori di lattoneria in genere.
- Colore del corpo del tassello: testa di moro.
- Estrema facilità e semplicità d'uso.

Code	Desc. $\varnothing \times L$	$\varnothing$ hole mm	Spes. max fissabile mm
155TA07200	6X40 PN	6	10
155TA07250	6X60 PN	6	30

## Tassello in nylon a percussione con vite in rame a testa coprente



Code	Desc. $\varnothing \times L$	$\varnothing$ hole mm	Spes. max fissabile mm
155TA04600	6X40 CS	6	10



## Tasselli rapidi a martello con rondella e guarnizione vulcanizzata



- Tassello a chiodo e rondella in inox A2. rondella vulcanizzata in gomma.
- Tassello in nylon.
- Fissaggio su: calcestruzzo, mattoni pieni.
- Per il fissaggio leggero di lamiera in rame, grondaie, scossaline, lamiera in acciaio inox ed in acciaio testa di moro.
- Settore di utilizzo: ideale per lavori vari di lattoneria.
- Vantaggi: montaggio veloce grazie alla vite a colpo.
- Ottima tenuta sulla lamiera grazie alla rondella.
- Fissaggio a tenuta stagna grazie alla gomma vulcanizzata sotto la rondella.
- Vite con impronta pz, per avvitare o rimuovere il tassello.

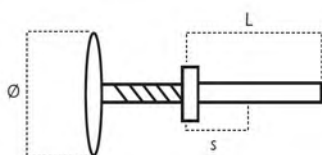

Code	Desc.	Ø hole mm	Ø Rondella mm	Lung. totale L mm	Spess. fissabile mm. (s)	Color
155TA08860	6X20 CR	6	20	40	10	Ramato
155TA08870	6X20 CT	6	20	40	10	Testa di moro
155TA08880	6X20 CI	6	20	40	10	Inox

## Tassello per ancoraggi su pareti vuote



### SEQUENZA DI MONTAGGIO

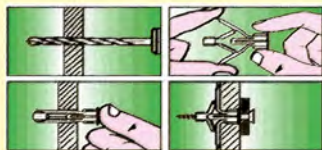

Code	Desc.	Ø hole mm	Dowel length mm	Spessore parete	Screw dim. mm
155TA08000	10X10	10	34	10	4,5X35
155TA08010	10X17	10	40	17	4,5X45
155TA08020	10X26	10	50	26	4,5X55

## Tassello in nylon autop perforante per cartongesso



- Tassello autop perforante in nylon.
- Da utilizzare su cartongesso e calcestruzzo cellulare (gasbeton). in quest'ultimo caso e' necessario per l'applicazione un preforo da 6mm.
- Settore di utilizzo: cartongessisti, impiantisti elettrici e termoidraulici.
- Punta auto-forante che permettere sul cartongesso un'istallazione facile e veloce senza preforo. Applicazione con avvitatore o giravite.
- Impronta tassello e vite PZ 2.
- Ideale per il fissaggio di supporti, canaline, impianti elettrici, ecc.
- Disponibile con vite e senza. L'articolo 155TA04999 e' utilizzabile con viti truciolari di diametro max 4,5 mm.

**SEQUENZA DI MONTAGGIO**

**VALORI DI ESTRAZIONE IN DaN (1 DAN=1Kg)**

Calcestruzzo cellulare	60
Cartongesso	25
Adottare un coefficiente di sicurezza (4-5)	

5

Code	Desc. ØxL body	Spes. max fissabile mm	Characteristics
155TA04999	8X38	-	Tassello senza vite
155TA05000	8X38 CG	12	Tassello con vite TPS Ø4,5x50 ZB imp. PZ2

## Tasselli in nylon per fissaggi su cappotti



- Tasselli in nylon con corpo a vite autofilettante per fissaggi su pannelli isolanti rigidi anche di tipo etics, avvitatura diretta senza bisogno di preforo facile e velocissima. permettono di ancorarsi ai sistemi a cappotto con spessori a partire da 60 mm.
- Indicati per tutti i settori di installazione impianti elettrici, idraulici, tubazioni pluviali, sistemi di allarme e videosorveglianza, ecc.
- Il materiale di cui sono composti non realizza ponti termici, permette di fissare in maniera stabile tutti gli oggetti anche pesanti e ne consente la rimozione e il rimontaggio.
- Resistenza agli agenti atmosferici ed agli sbalzi di temperatura. installazione possibile su pannelli in polistirene/polistirolo, polistirene estruso, tutti i tipi di pannelli termoisolanti ed acustici rigidi.
- La posa in opera si realizza avvitando direttamente i tasselli nel materiale isolante tramite una punta con impronta torx t40 per il codice 155 ta 10330 ed una chiave a bussola esagonale da 13 mm per il codice 155 ta 10335.
- Il fissaggio si ottiene usando viti autofilettanti per truciolare di diametro 4,5 o 5 mm per il tassello più piccolo. nel tassello più grande possono essere inserite viti metriche m8 oppure viti autofilettanti per truciolare di diametro 8 o 10 mm.
- \*Fornito con vite TE 8X30 per il montaggio del tassello

Code	Description	Insert to use	Ø screw mm	Leng. mm	Spessore isolante mm
155TA10330	60/SC	Torx T40	4,5-5,0	30 + spessore fissaggio	>= 60
155TA10335	95/SC*	Vite TE ch.13	M8 o Ø 8-10	40 + spessore fissaggio	>= 100

## Tasselli in nylon per fissaggio cappotti Ø8



Categorie di utilizzo A-B-C-D-E



- Tassello speciale con testa extra larga ed espansione a chiodo specifici per il fissaggio dei pannelli isolanti per sistemi a cappotto di spessore a partire da 45 mm., sia rigidi sia soffici.
- Indicato per tutte le operazioni di posa in opera o riparazione dei sistemi isolanti a cappotto.
- Corpo del tassello in nylon isolante, esente da conduzione termica, chiodo in nylon rinforzato con fibra di vetro, certificati ce con benessere tecnico europeo per categorie di utilizzo a-b-c-d-e.
- Permette di fissare pannelli lamellari in lana di vetro/lana di roccia, misti lana di vetro/roccia, pannelli in polistirene e polistirolo, polistirene estruso. Applicazioni possibili su calcestruzzo, calcestruzzo aerato, calcestruzzo vibrocompresso aerato aggregato, mattone pieno, mattone in ceramica, mattone forato.
- L'applicazione è semplice e velocissima, la lunghezza ridotta permette forature di profondità minima.
- L'espansione del tassello si ottiene piantando il chiodo dopo l'applicazione.

5

### SEQUENZA DI MONTAGGIO



Attendere che la colla/sigillante



Forare il supporto con punta

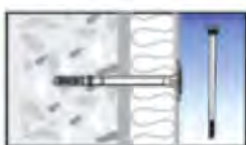

Inserire il tassello di Nylon fin-  
chè la rondella non aderisce  
al pannello



Inserire a martello il chiodo fino  
a espansione ultimata

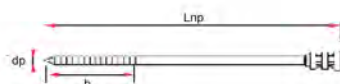
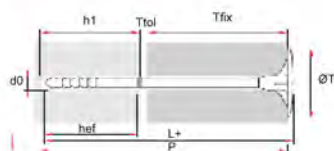

Lt= Lunghezza tassello  
h1= Profondità minima foro  
d0= Diametro foro  
hef= Profondità di ancoraggio  
Tfix = Spessore fissabile  
P = Profondità complessiva fori  
dp = Diametro del chiodo  
Lnp = Lunghezza chiodo  
b = Lunghezza zigrinatura chiodo  
Ttol = Spessore strato colla/intonaco

Code	Desc.	Lt mm	d0 mm	h1 mm	hef mm	Tfix mm	P mm	Ø T mm	Dp mm	Lnp mm	b mm
155TA10340	8/95PC	95	8	60	50	45-Ttol	Tfix+Ttol+Hef	60	4,8	100	44
155TA10345	8/115PC	115	8	60	50	65-Ttol	Tfix+Ttol+Hef	60	4,8	120	44
155TA10350	8/135PC	135	8	60	50	85-Ttol	Tfix+Ttol+Hef	60	4,8	140	44
155TA10355	8/155PC	155	8	60	50	105-Ttol	Tfix+Ttol+Hef	60	4,8	160	44
155TA10360	8/175PC	175	8	60	50	125-Ttol	Tfix+Ttol+Hef	60	4,8	180	44
155TA10365	8/195PC	195	8	60	50	145-Ttol	Tfix+Ttol+Hef	60	4,8	200	44

## Disco ISO CE 140 per tasselli Ø 8 mm



- Disco allargatore per tasselli in nylon fissaggio cappotti Ø 8 mm.
- Permette di allargare il diametro della testa fino a 140 mm.
- Indicato per il fissaggio dei materiali più soffici quali pannelli in lana di vetro o lana di roccia, polistirolo, ecc.

5



Categorie di utilizzo A-B-C-D-E

Legenda di categorie di utilizzo	Materiale da costruzione
A	Calcestruzzo
B	Muratura piena
C	Muratura forata
D	Calcestruzzo aerato alleggerito
E	Calcestruzzo vibrocompresso aerato

Resistenza all'estrazione in daN (1 daN = 1 kg) Materiale da costruzione			
Materiale	Classe materiale	Standard	daN
Calcestruzzo C12/15	A	EN 206-1	40
Calcestruzzo C20/25 - C50/60	A	EN 206-1	60
Mattone pieno/mattone in ceramica	B	EN 771-1	40
Calcestruzzo vibrocompresso aerato alleggerito	D	EN 771-3	30
Calcestruzzo aerato autoclavato	E	EN 771-4	40

Valori caratteristici di caricabilità secondo ETA

Coefficiente di sicurezza raccomandato = 2

Code	Description
155TA10370	140PC



## Tasselli in nylon per fissaggio cappotti Ø10



- Tassello speciale con testa extra larga ed espansione a chiodo specifici per il fissaggio dei pannelli isolanti rigidi per sistemi a cappotto di spessore a partire da 20 mm.
- Indicato per tutte le operazioni di posa in opera o riparazione dei sistemi isolanti a cappotto.
- Corpo del tassello in nylon isolante, esente da conduzione termica, chiodo in nylon rinforzato con fibra di vetro, certificati ce con benessere tecnico europeo per categorie di utilizzo a-b-d-e.
- Permette di fissare pannelli in polistirene/polistirolo, polistirene estruso. applicazioni possibili su calcestruzzo, calcestruzzo aerato, calcestruzzo vibrocompresso aerato aggregato, mattone pieno, mattone in ceramica.
- L'applicazione è semplice e velocissima, la lunghezza ridotta permette forature di profondità minima.
- L'espansione del tassello si ottiene piantando il chiodo dopo l'applicazione.

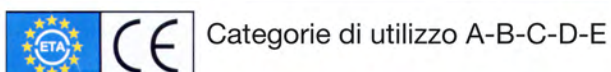

SEQUENZA DI MONTAGGIO



Attendere che la colla/sigillante Forare il supporto con punta



Inserire il tassello di Nylon finché la rondella non aderisce al pannello  
Inserire a martello il chiodo fino a espansione ultimata

Legenda di categorie di utilizzo	Materiale da costruzione
A	Calcestruzzo
B	Muratura piena
C	Muratura forata
D	Calcestruzzo aerato alleggerito
E	Calcestruzzo vibrocompresso aerato

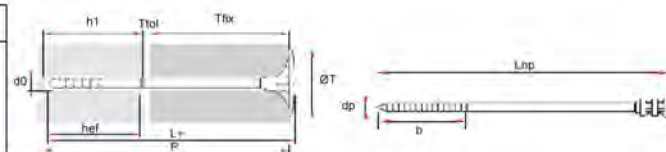

Resistenza all'estrazione in daN (1 daN = 1 kg)			
Materiale	Classe materiale	Standard	daN
Calcestruzzo C12/15	A	EN 206-1	50
Calcestruzzo C20/25 - C50/60	A	EN 206-1	75
Mattoni pieni/mattoni in ceramica	B	EN 771-1	60
Calcestruzzo vibrocompresso aerato alleggerito	D	EN 771-3	50
Calcestruzzo aerato autoclavato	E	EN 771-4	40

Lt= Lunghezza tassello  
 h1= Profondità minima foro  
 d0= Diametro foro  
 hef= Profondità di ancoraggio  
 Tfix = Spessore fissabile  
 P = Profondità complessiva fori  
 dp = Diametro del chiodo  
 Lnp = Lunghezza chiodo  
 b = Lunghezza zigrinatura chiodo  
 Ttol = Spessore strato colla/intonaco

Valori caratteristici di caricabilità secondo ETA  
 Coefficiente di sicurezza raccomandato = 2

Code	Desc.	Lt mm	d0 mm	h1 mm	hef mm	Tfix mm	P mm	Ø T mm	Dp mm	Lnp mm	b mm
155TA10375	10/110PC	110	10	60	50	60-Ttol	Tfix+Ttol+Hef	60	5,5	115	44
155TA10380	10/120PC	120	10	60	50	70-Ttol	Tfix+Ttol+Hef	60	5,5	125	44
155TA10385	10/140PC	140	10	60	50	80-Ttol	Tfix+Ttol+Hef	60	5,5	145	44
155TA10390	10/160PC	160	10	60	50	100-Ttol	Tfix+Ttol+Hef	60	5,5	165	44



## Tassello in zama autoperforante ad ancora per cartongesso con vite



### SEQUENZA DI MONTAGGIO



Code	Desc. ØxL body	Spess. serrabile mm
1550000010	8X39 ZC	0-12

5

### CARICHI DI RESISTENZA SU CARTONGESSO mm10

TRAZIONE TAGLIO	Kg 42 Kg 115	SI CONSIGLIA UN COEFFI- CIENTE DI SICUREZZA ~ 4
--------------------	-----------------	--

## Tassello zamak



### INDICAZIONI DI POSA

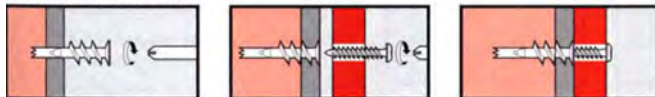

### CARICHI DI RESISTENZA

	TRAZIONE	TAGLIO
CARTONGESSO	30 Kg	90 Kg
CALCESTRUZZO CELLULARE	30 Kg	90 Kg

Code	Desc.	Screw dim. mm	Spes. max fissabile mm	Ø Testa tassello mm	Ø Testa vite mm	Dowel length mm
1550009499	T	-	-	13	-	37
1550009500	TP12	4,5X35 TC	12	13	9,2	37
1550009510	TF5	4,5X25 TS	5	13	8,2	37
1550009520	TF27	4,5X50 TS	27	13	8,8	37

## Tassello in nylon con vite TE e gancio



- Ancorante in nylon con cono di espansione in ottone.
- Fornito con vite te in acciaio zincato.
- Adatto per fissaggi su materiali edili, principalmente indicato per fissaggi su mattoni forati.

INDICAZIONI DI POSA



VALORI DI ESTRAZIONE IN DaN (1 DAN=1Kg)

TASSELLO	155 00 04700 29/8x80	155 00 04750 29/10x80
Calcestruzzo Rc 250*	220	450
Mattoni forati	100	120
* Rc 250 = 25 N/mm <sup>2</sup>		
Adottare un adeguato coefficiente di sicurezza (4/5)		

Code	Description	Ø hole mm	Hole depth mm	Ø screw mm	Spess. fissabile mm. (s)
1550004700	29/8x80 - Tassello in nylon + vite TE	12	80	M8x80	10
1550004750	29/10x80 - Tassello in nylon + vite TE	14	80	M10x80	8
1550004760	30/10x8 - Tassello in nylon + gancio	14	80	M10x80	-

## Viti di congiunzione con tassello in nylon



- **Applicazioni:** Fissaggi a muro, tramite tassello in nylon di staffe, supporti, cassette, canaline, scaffalature, ecc.
- **Caratteristiche:** Tassello in nylon per supporti pieni e forati, vite zincata: da un lato passo ma, dall'altro filetto per tassello.

Code	Description	Vite Ø x lung.	Tassello Ø x lung.
1550004650	28/8x90 - vite di cong.	M8x90	10x60
1550004660	28/10x120 - vite di cong.	M10x120	12x60

## Tassello per supporti vuoti in acciaio



- Corpo e vite in acciaio.
- Vite testa cilindrica con impronta a croce.
- Punta incisiva antirotazione sulla testa del tassello.
- Aperura ad ombrello del tassello per contrastare il carico.
- Per pannelli di cartongesso. Pannelli di legno. Pareti leggere. Pareti vuote. Blocchi e laterizi forati.

CARICHI DI ROTTURA (1 da N ≈ 1 Kg.)

Materiale/Tassello	Ø 7	Ø 9	Ø 10
Cartongesso sp ≥ 13 mm	20 da N	25 da N	25 da N
Trazione/Taglio			

Code	Desc.	Ø tass. mm	Lung. tass. mm	Spess. Supp. Min/max mm	Screw Diam. Ø X length
1550004510	25/7X32	7	32	3-9	M4X40
1550004520	25/7X38	7	38	8-15	M4X46
1550004530	25/7X45	7	45	3-20	M4X53
1550004550	25/9X52	9	52	3-16	M4X57
1550004560	25/9X65	9	65	14-32	M4X70
1550004570	25/10X52	10	52	3-16	M4X57
1550004580	25/10X65	10	65	14-32	M4X70

## Utensile per tiraggio tasselli per supporti vuoti

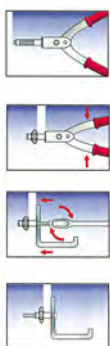

- Utensile per tiraggio tasselli per supporti vuoti.

Code	Desc.	Characteristics
1550004940	32	Utensile di posa

5

## Ancorante in acciaio a farfalla

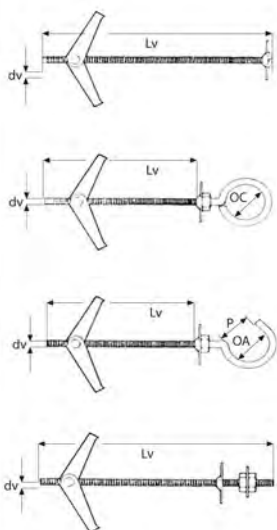

Code	Desc.	Ø Foratura mm	Dim. Access dv x Lv mm	OC/OA mm	P mm	Photo
1550010630	92V	14	M5 X 75	/	/	1
1550010640	92OC	14	M5 X 65	14	/	2
1550010650	92OA	14	M5 X 65	14	11	3
1550010660	92DD	14	M5 X 95	/	/	4

## Ancore basculanti in acciaio M6 - M8

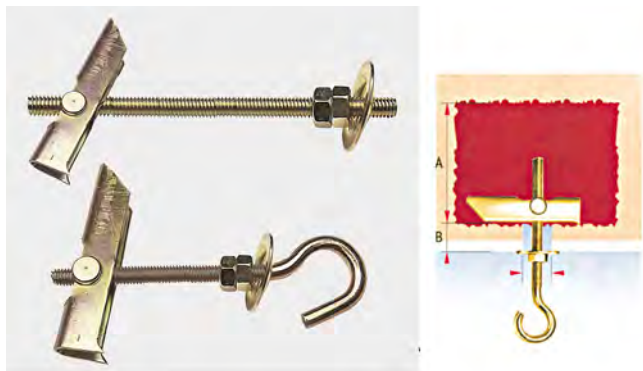

INDICAZIONE DI POSA:

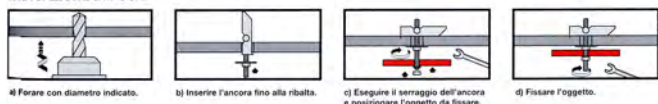

CODICE	CAUSA	CARICO DI ROTTURA DaN
155000060	ROTTURA DEL SISTEMA	360
155000070	STIRAMENTO OCCHIOLO	95
155000080	ROTTURA DEL SISTEMA	1000
155000090	STIRAMENTO OCCHIOLO	150

Carichi di rottura in DaN (1 DaN=1 Kg)

Code	Description	Screw size MxL v	Ø hole mm	Dim. Access dv x Lv mm
155000060	15/V-ancora basc.+vite M6	M6X100	16	6X100
155000070	15/OA - ancora basc.oc. aperto	M6X100	16	6X100
155000080	16/V-ancora basc.+vite M8	M8X100	20	8X100
155000090	16/OA-ancora basc.oc. aperto M8	M8X100	20	8X100

## Tassello in acciaio completo di pitoneria

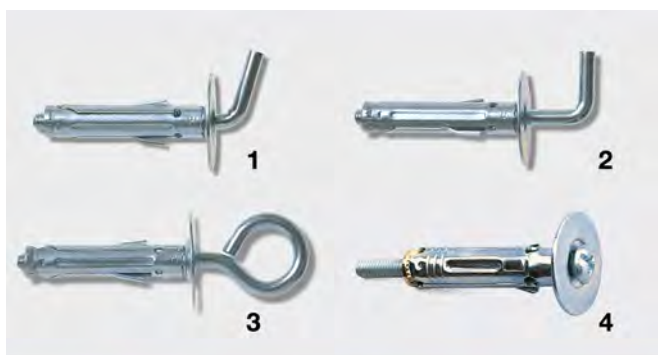

SEQUENZA DI MONTAGGIO



VALORI DI ESTRAZIONE IN daN (1 daN=1kg)		
Calcestruzzo R250 (250 Kg/cm2)	ø.8	ø.9
Vite TGS	190	250
Gancio corto	50	130
Gancio medio	35	65
Occhiole chiuso	35	65

- Tassello per fissaggi leggeri di mensole, staffe, piccoli profili metallici
- Disponibile in due diametri e con una vasta gamma di accessori per soddisfare ogni esigenza di fissaggio
- Corpo in lamiera zincata con cono di espansione in metallo, dotato di alette anti rotazione e rondella extra larga per una migliore distribuzione dello sforzo e per non rovinare le pareti del supporto
- L'avvitamento dell'accessorio provoca il richiamo del corpo espansore e la conseguente apertura del corpo in tre parti
- Indicato per pareti in calcestruzzo, mattoni pieni, mattoni semipieni, pietra naturale, per applicazioni in prossimità di fonti di calore (tubature, staffe per caloriferi)
- **Importante:** applicare un coefficiente di sicurezza adeguato ad ogni singolo caso

Code	Desc. ØxL body	Installed accessory	Photo
1550000100	8X38 mm A/GC	Gancio corto sporg. 4mm	1
1550000110	9X38 mm A/GC	Gancio corto sporg. 4,5mm	1
1550000120	8X38 mm A/GM	Gancio medio sporg. 10mm	2
1550000130	9X38 mm A/GM	Gancio medio sporg. 10mm	2
1550000180	8X38 mm A/OC	Occhiole chiuso ø int. 13mm	3
1550000200	8X38 mm A/V	Vite TGS taglio comb. L-52mm	4
1550000210	9X38 mm A/V	Vite TGS taglio comb. L-55mm	4

## Tassello in acciaio per controsoffitti

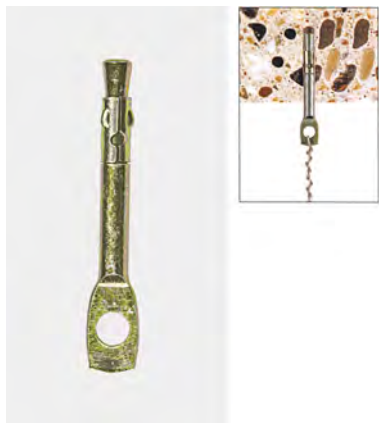

Code	Desc.	Ø hole mm	Depth installation mm
1550001050	6X50 CX	6	30
1550001060	6X60 CX	6	45

5

## Tassello ad espansione in ottone



- Tassello completamente in ottone con filettatura interna metrica.
- L'espansione viene ottenuta per effetto dell'avvitatura della vite o dell'accessorio grazie alla forma conica della parte interna finale.
- Ottimo per l'impiego su materiali compatti quali; calcestruzzo mattoni pieni, pietra naturale e legno duro, di ridotto spessore portante, o in ambienti corrosivi (impianti idraulici, elettrici, su strutture in legno, ecc.).
- Ampia espansione e corpo zigrinato per un'ottima presa nei materiali piu' leggeri.

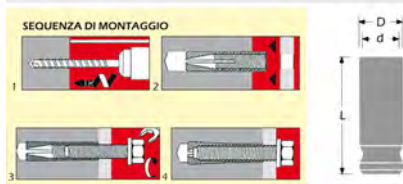

Code	Desc. dxL	Ø hole mm	Thread internal
1550000310	8x23/OT	8	M 6
1550000320	10x28/OT	10	M 8
1550000330	12x34/OT	12	M 10



## Tassello in acciaio con vite "TE" e "TSP" per fissaggi passanti

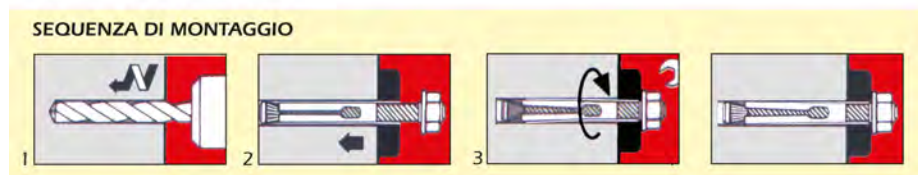

VALORI DI ESTRAZIONE IN daN (1 daN $\cong$ 1kg)				
MATERIALI DI SUPPORTO	$\phi$ .8	$\phi$ .10	$\phi$ .12	$\phi$ .14
Calcestruzzo R250 (250 Kg/cm <sup>2</sup> )	150	230	400	600
Coppia di serraggio Nm	10	25	50	50

Dati tecnici dei tasselli in acciaio con vite "TE" per fissaggi passanti

Code	Desc. $\phi$ xL body	$\phi$ hole mm	Spes. max fissabile mm	Testa mm	Lung. tass. mm	$\phi$ screw mm	Wrench	Type
1550001000	8X50/FL TE	8	10	10	-	-	-	Tasselli con vite TE 8.8
1550001005	8X65/FL TE	8	25	10	-	-	-	Tasselli con vite TE 8.8
1550001010	10X70/FL TE	10	10	13	-	-	-	Tasselli con vite TE 8.8
1550001013	10X100/FL TE	10	55	13	-	-	-	Tasselli con vite TE 8.8
1550001015	10X120/FL TE	10	75	13	-	-	-	Tasselli con vite TE 8.8
1550001020	12X70/FL TE	12	25	17	-	-	-	Tasselli con vite TE 8.8
1550001023	12X100/FL TE	12	45	17	-	-	-	Tasselli con vite TE 8.8
1550001025	12X120/FL TE	12	65	17	-	-	-	Tasselli con vite TE 8.8
1550001030	14X70/FL TE	14	10	17	-	-	-	Tasselli con vite TE 8.8
1550008350	8X45 TPS	8	10	-	45	M 6x50	4	Tasselli con viteTSP EI 10.9
1550008360	8X65 TPS	8	25	-	65	M 6x70	4	Tasselli con viteTSP EI 10.9
1550008370	10X50 TPS	10	10	-	50	M 8x60	5	Tasselli con viteTSP EI 10.9
1550008380	10X70 TPS	10	25	-	70	M 8x80	5	Tasselli con viteTSP EI 10.9
1550008390	10X100 TPS	10	45	-	100	M 8x100	5	Tasselli con viteTSP EI 10.9
1550008400	12X60 TPS	12	10	-	60	M 10x65	6	Tasselli con viteTSP EI 10.9
1550008410	12X80 TPS	12	25	-	80	M 10x80	6	Tasselli con viteTSP EI 10.9
1550008420	12X100 TPS	12	45	-	100	M 10x100	6	Tasselli con viteTSP EI 10.9

## Ancorante in acciaio per supporti compatti



5

ANCORANTE IN ACCIAIO PER SUPPORTI COMPATTI				
Valori di estrazione in daN (1 kN = 100 Kg)				
ANCORANTE	M6	M8	M10	M12
Trazione	5,5	7,5	13,5	15
Taglio	10	16	24	30

Code	Desc.	Ø hole mm	Hole depth mm	Thread internal	Model
1550004010	25/6	12	50	M6	Corpo espansore
1550004020	25/8	14	55	M8	Corpo espansore
1550004030	25/10	16	65	M10	Corpo espansore
1550004050	26/6	12	80	M6X50	Corpo espansore con vite TE in acciaio classe 8.8 e rondella maggiorata
1550004060	26/8	14	65	M8X60	Corpo espansore con vite TE in acciaio classe 8.8 e rondella maggiorata
1550004070	26/10	16	75	M10X80	Corpo espansore con vite TE in acciaio classe 8.8 e rondella maggiorata
1550004075	26/12	20	95	M12X90	Corpo espansore con vite TE in acciaio classe 8.8 e rondella maggiorata

## Ancoranti medio pesanti in acciaio



VALORI DI ESTRAZIONE IN KN (1 KN=100KG) SU CALCESTRUZZO Rc>25 N/mm <sup>2</sup>				
Ancorante	Diametro 10	Diametro 12	Diametro 14	Diametro 18
Viteria cl. 8.8	3.2	4.0	5.0	7.7
Coppia di serraggio Nm	10	25	50	85

Code	Desc. dXI mm	Meas. Screws mm	Spess. serrabile mm	Wrench mm	For screws d.	Model
1550007500	10X45/MV	6X55	5	10	-	ANCORANTI CON VITE TE
1550007550	12X50/MV	8X60	10	13	-	ANCORANTI CON VITE TE
1550007600	14X60/MV	10X80	20	17	-	ANCORANTI CON VITE TE
1550007650	18X75/MV	12X100	25	19	-	ANCORANTI CON VITE TE
1550007300	10X45/MP	-	-	-	M6	ANCORANTI SENZA ACCESSORI
1550007350	12X50/MP	-	-	-	M8	ANCORANTI SENZA ACCESSORI
1550007400	14X60/MP	-	-	-	M10	ANCORANTI SENZA ACCESSORI
1550007450	18X75/MP	-	-	-	M12	ANCORANTI SENZA ACCESSORI

## Steel gusset four sectors with hexagonal screw



- Anchor steel for heavy loads and hardware on surfaces such as concrete poor, old and inhomogeneous materials, natural stone.
- Building four steel segments joined by spring, screw hexagon 8.8, washer and expander cone steel.
- Yellow zinc min. 8 microns.

INDICAZIONI DI POSA

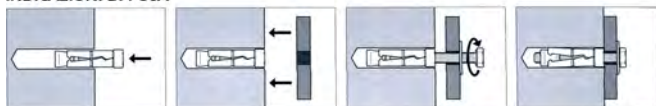

VALORI DI ESTRAZIONE IN KN (1 KN=100KG) SU CALCESTRUZZO Rc>25 N/mm2				
Ancorante	Diametro 10	Diametro 12	Diametro 14	Diametro 18
Viteria inox AZ-R70	3.0	3.9	4.7	7.0
Coppia di serraggio Nm	10	25	50	85

Code	Desc.	Ø hole mm	Screw ØxL mm	Tigh. thickness. mm	Wrench mm	Tightening torque Nm
1550004900	31/6x50	12	M6x50	10	10	6,5
1550004910	31/8x60	14	M8x60	15	13	16
1550004920	31/10x80	16	M10x80	25	17	28
1550004930	31/12x90	20	M12x90	25	19	50

## Ancorante in acciaio per carichi pesanti CE 1



CARICHI CONSIGLIATI E PRESTAZIONI COME DA CERTIFICAZIONE CE OPZIONE 1 SU CALCESTRUZZO NON FESSURATO CLS Rck = C20/25 KN (1KN = 100KG)					CARICHI CONSIGLIATI E PRESTAZIONI COME DA CERTIFICAZIONE CE OPZIONE 1 SU CALCESTRUZZO FESSURATO CLS Rck=C20/25 - KN (1KN=100KG)				
Ancorante	M6	M8	M10	M12	Ancorante	M6	M8	M10	M12
Trazione (KN)	7,6	9,5	14,3	17,2	Trazione (KN)	2,4	5,7	7,6	12,3
Taglio (KN)	10,1	17,1	27,5	34,3	Taglio (KN)	10,1	15,9	20,5	20,5

Code	Desc. Lt x d mm.	Hole depth (h1) mm	Vite	Ø foro (do) mm	Spe. Fissabile (Tfix) mm	Tightening torque (Tinst) mm	Wrench (ch)
1550005500	10X75/EE	65	M6	10	10	15	10
1550005600	12X107/EE	80	M8	12	30	30	13
1550005650	12X127/EE	80	M8	12	50	30	13
1550005700	16X118/EE	95	M10	16	25	50	17
1550005750	16X138/EE	95	M10	16	45	50	17
1550005800	18X117/EE	105	M12	18	10	80	19
1550005850	18X147/EE	105	M12	18	40	80	19

# Ancorante in acciaio ad elevate prestazioni



5

Carichi max ammissibili in daN per applicazioni in calcestruzzo di classe R <sub>t</sub> = 25 N/mm <sup>2</sup>						
ANCORANTE	Ø 6	Ø 8	Ø 10	Ø 12	Ø 16	Ø 20
[1 da N = 1 Kg]	230	360	480	870	1150	1630
<b>CONDIZIONI DI INSTALLAZIONE</b>						
Interasse critico tra ancoranti a <sub>1</sub> (mm)	180	190	220	300	380	440
Distanza critica dal bordo a <sub>1</sub> (mm)	70	80	100	120	170	220
Interasse minima tra ancoranti a min. (mm)	90	95	110	150	190	220
Distanza minima dal bordo a <sub>1</sub> min. (mm)	35	40	50	60	85	105
Spessore minimo supporto S (mm)	100	100	100	150	180	210
Coppia serraggio Nm	8	20	45	65	115	200

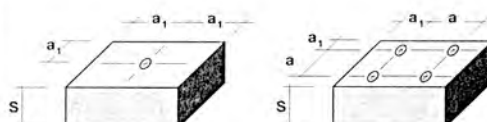

## SEQUENZA DI MONTAGGIO

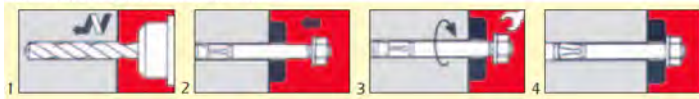

**IL RIQUADRO RIPORTA I CARICHI AMMISSIBILI IN daN IN CONSIDERAZIONE DI:**  
 SOLLECITAZIONI APPLICATE IN QUALSIASI DIREZIONE (TRAZIONE ASSIALE, TAGLIO, TIRO INCLINATO)  
 ANCORANTI INSTALLATI CON DISTANZE DAL BORDO E DISTANZE TRA ANCORANTI UGUALI O SUPERIORI A QUELLE  
 CRITICHE, PER DISTANZE INFERIORI A QUELLE CRITICHE E' NECESSARIO RIDURRE I CARICHI AMMISSIBILI  
 SPESSORI DI SUPPORTO UGUALI O MAGGIORI A QUELLI RIPORTATI

Code	Desc. ØxL body	Spes. max fissaggio mm	Ø hole mm
1550000370	6X65/EP	10	6
1550000380	6X80/EP	25	6
1550000390	6X100/EP	40	6
1550000400	8X50/EP	5	8
1550000410	8X75/EP	10	8
1550000420	8X90/EP	25	8
1550000425	8X115/EP	50	8
1550000434	8X130/EP	70	8
1550000436	8X160/EP	100	8
1550000440	10X75/EP	10	10
1550000450	10X90/EP	20	10
1550000455	10X120/EP	50	10
1550000457	10X140/EP	70	10
1550000458	10X170/EP	100	10
1550000460	12X70/EP	5	12
1550000465	12X90/EP	15	12
1550000470	12X110/EP	20	12
1550000480	12X140/EP	50	12
1550000485	12X180/EP	85	12
1550000488	16X90/EP	15	16
1550000490	16X145/EP	30	16
1550000500	16X175/EP	60	16
1550000510	20X170/EP	30	20
1550000520	20X220/EP	80	20



## Ancorante in acciaio ad elevate prestazioni CE 7



CONDIZIONI DI ISTALLAZIONE				
MISURA	M8	M10	M12	M16
Interasse critico a (mm)	144	180	210	270
Distanza critica dal bordo a l (mm)	72	90	105	135
Interasse minima a min (mm)	48	60	72	96
Distanza minima dal bordo a l min (mm)	64	80	96	128
Spessore minimo del supporto S min (mm)	110	120	160	200
Coppia di serraggio (Nm)	15	30	50	100

### SEQUENZA DI MONTAGGIO



CARICHI CONSIGLIATI IN KN (1 KN = 100Kg)				
MISURA	M8	M10	M12	M16
Trazione KN	3,6	4,3	5,7	9,9
Taglio KN	3,8	5,8	12	22,4

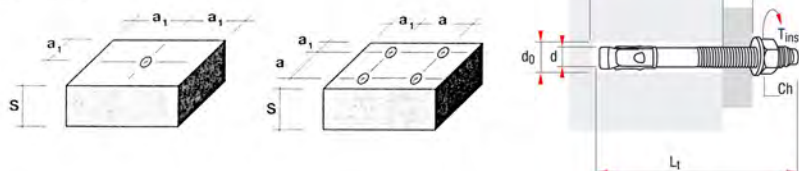

- Ancorante in acciaio ad elevate prestazioni, per fissaggi sicuri ad elevata tenuta.
- Settore di utilizzo: carpenteria metallica, impiantistica elettrica, termoidraulica, ed edilizia.
- Indicato per fissaggi passanti di strutture metalliche, ringhiere, scale, parapetti, cancelli, binari, profili, porte industriali.
- Applicabile su calcestruzzo non fessurato e pietra naturale.
- Dotato di certificazione CE con benessere tecnico europeo opzione 7, per l'utilizzo su calcestruzzo non fessurato.
- Boccola di espansione a sagomatura speciale per rendere l'espansione morbida e progressiva e per impedire la rotazione durante l'installazione.
- Alta resistenza a taglio e trazione.
- L'ancorante e' costituito da: perno, dado, rondella in acciaio e fascetta di espansione in inox A2.

Code	Descr. mm dxLt	Lung. anchor (Lt) mm	Ø foro (do) mm	Lung. Foro h1 mm	Max fixing thickness (tfix) mm	Tightening torque (Tinst) mm	Wrench (ch)
1550010400	8X75/EP7	75	8	65	10	15	13
1550010410	8X90/EP7	90	8	65	20	15	13
1550010420	8X115/EP7	115	8	65	45	15	13
1550010470	10X80/EP7	80	10	70	10	30	17
1550010480	10X90/EP7	90	10	70	20	30	17
1550010490	10X120/EP7	120	10	70	50	30	17
1550010500	12X100/EP7	100	12	95	5	50	19
1550010510	12X110/EP7	110	12	95	15	50	19
1550010520	12X140/EP7	140	12	95	45	50	19
1550010530	12X180/EP7	180	12	95	85	50	19
1550010540	12X200/EP7	200	12	95	105	50	19
1550010600	16X145/EP7	145	16	120	30	100	24
1550010610	16X175/EP7	175	16	120	60	100	24
1550010620	16X220/EP7	220	16	120	105	100	24



## Tassello passante da fissaggio pesante con testa asportabile

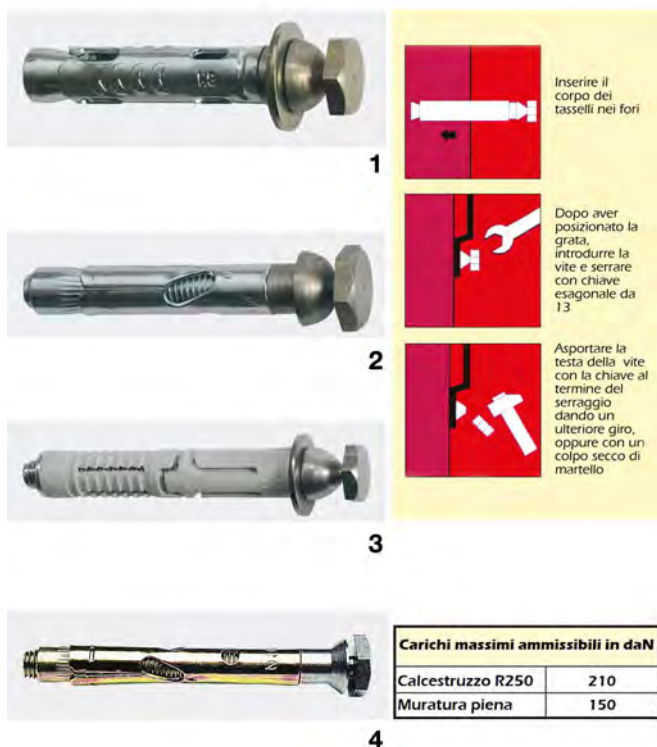

5

Code	Desc. <i>ØxL body</i>	Ø hole <i>mm</i>	Spess. serrabile <i>mm</i>	Model	Photo
1550002000	12x55/TSC mm	12	5	Per murature compatte	1
1550002100	12x75/TSC mm	12	20	Per murature compatte	1
1550002200	12x95/TSC mm	12	40	Per murature compatte	1
1550002300	10x55/TSS mm	10	5	Per murature semicompatte	2
1550002400	10x75/TSS mm	10	20	Per murature semicompatte	2
1550002500	12x75/TSN mm	12	5	Per murature forate	3
1550002600	10x95/TSN mm	12	25	Per murature forate	3
1550001800	10x55/TS mm	10	6	Testa svasata per murature semicompatte	4
1550001900	10x75/TS mm	10	25	Testa svasata per murature semicompatte	4

## Dadi inox A2 filettati con foro passante a testa staccabile



Code	Desc.	Thread	L <i>mm</i>	Wrench mm
1550002650	19/1-M8	8X1,25	8X1,25	17
1550002660	19/2-M10	10X1,5	10X1,5	19

## Dadi inox A2 filettati M8 a testa staccabile



**SEQUENZA DI MONTAGGIO**



Asportare la testa della vite con la chiave al termine del serraggio dando un ulteriore giro, oppure con un colpo secco di martello



Code	Description	Step	Ø 01mm	Ø 02 mm	L mm	Wrench mm
1550002690	19/6	8x1,25	12	14,5	6	15
1550002700	19/7	8x1,25	10	14,5	6	15

## Tasselli passanti in acciaio con vite Torx antieffrazione



**ISTRUZIONI PER IL MONTAGGIO**

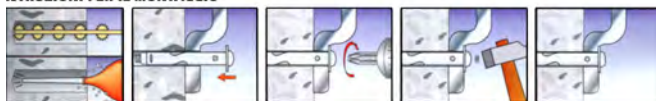

Code	Desc.	Ø hole mm	Length	Spess. serrabile mm	Wrench mm	Tightening torque Nm	L. screw
1550009000	8X50	10	50	6	T40	14	M8X55
1550009100	8X80	10	80	25	T40	14	M8X80
1550009200	8X100	10	100	45	T40	14	M8X100

## Viti antieffrazione di sicurezza con filetto per tasselli



Code	Desc.	Leng. mm	Ø Testa Vite mm	Intaglio Torx
1770300100	7X70	70	17	T40
1770300200	7X80	80	17	T40
1770300300	7X90	90	17	T40
1770300400	7X105	105	17	T40
1770300500	7X120	120	17	T40

5

## Viti metriche antieffrazione di sicurezza



Code	Desc.	Leng. mm	Screw Diam.	Intaglio Torx
1770400200	8X60	60	M8	T40
1770400600	8X100	100	M8	T40

## Tappo di sicurezza



- Per rendere i tasselli e le viti torx T40 antifurto.

Code	Desc.
1770300010	10

## Viti autofilettanti per fissaggio infissi

- Il sistema piu' semplice per il fissaggio di porte ed infissi in alluminio, legno e pvc direttamente sulla muratura senza l'utilizzo di tasselli o ancoranti.
- La costruzione particolare di queste viti permette un fissaggio sicuro ed eterno su ogni tipo di muratura piena.
- Per effettuare il montaggio e' necessario preforare la muratura con una punta di diametro 6 mm, mentre il profilo dell'infisso deve essere preparato con dei fori di diametro 6,5 mm.
- Testa dalla particolare forma svasata piana con impronta torx T30.



Come scegliere la lunghezza della vite



Code	Desc. dXI mm	A mm	H mm	D1	P mm	Imprint
1770200060	7,5x52	10,4 - 11,1	2,7 - 3,1	7,3 - 7,6	2,3 +/- 10%	T30
1770200080	7,5x62	10,4 - 11,1	2,7 - 3,1	7,3 - 7,6	2,3 +/- 10%	T30
1770200100	7,5x72	10,4 - 11,1	2,7 - 3,1	7,3 - 7,6	2,3 +/- 10%	T30
1770200150	7,5x82	10,4 - 11,1	2,7 - 3,1	7,3 - 7,6	2,3 +/- 10%	T30
1770200200	7,5x92	10,4 - 11,1	2,7 - 3,1	7,3 - 7,6	2,3 +/- 10%	T30
1770200300	7,5x112	10,4 - 11,1	2,7 - 3,1	7,3 - 7,6	2,3 +/- 10%	T30
1770200400	7,5x132	10,4 - 11,1	2,7 - 3,1	7,3 - 7,6	2,3 +/- 10%	T30
1770200500	7,5x152	10,4 - 11,1	2,7 - 3,1	7,3 - 7,6	2,3 +/- 10%	T30
1770200600	7,5x182	10,4 - 11,1	2,7 - 3,1	7,3 - 7,6	2,3 +/- 10%	T30

## Viti per cemento testa cilindrica Torx Ø 5 mm

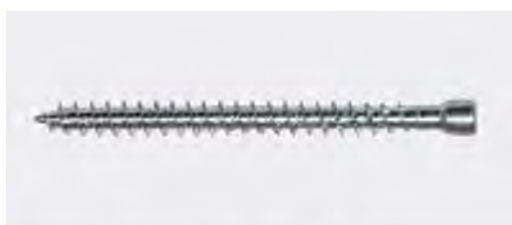

Come scegliere la lunghezza della vite



Code	Desc. dxL	A mm	H mm	d1 mm	P mm	Imprint
1770207010	5x52	5,00-5,20	2,20-2,50	4,80-5,00	2,20+/-10%	T15
1770207020	5x62	5,00-5,20	2,20-2,50	4,80-5,00	2,20+/-10%	T15
1770207030	5x72	5,00-5,20	2,20-2,50	4,80-5,00	2,20+/-10%	T15
1770207040	5x82	5,00-5,20	2,20-2,50	4,80-5,00	2,20+/-10%	T15
1770207050	5x92	5,00-5,20	2,20-2,50	4,80-5,00	2,20+/-10%	T15

## Concrete screws Torx head screws Ø 7.5 mm



- Self-tapping screws and self-tapping primarily used for fastening aluminum frames, wood or PVC on concrete, cement, solid brick and perforated. Usable for any type of direct fixing without use of other expansion anchors.
- The particular shape spinner and the self-tapping thread with chip breakers allow easy insertion without effort on the part of the screwdrivers. Fixing is safe and eternal.
- For fixing it requires a pilot hole diameter of 6 mm, Torx T30 across the range, ability to use the appropriate plugs screw covers supplied separately.

Come scegliere la lunghezza della vite



Code	Desc.	A mm	H mm	d1 mm	P mm	Imprint Torx
1770200900	7,5X52	8,35-8,50	3,90-4,20	7,30-7,60	2,30 +/- 10%	T 30
1770200950	7,5X62	8,35-8,50	3,90-4,20	7,30-7,60	2,30 +/- 10%	T 30
1770201000	7,5X72	8,35-8,50	3,90-4,20	7,30-7,60	2,30 +/- 10%	T 30
1770201050	7,5X82	8,35-8,50	3,90-4,20	7,30-7,60	2,30 +/- 10%	T 30
1770201100	7,5X92	8,35-8,50	3,90-4,20	7,30-7,60	2,30 +/- 10%	T 30
1770201200	7,5X112	8,35-8,50	3,90-4,20	7,30-7,60	2,30 +/- 10%	T 30
1770201300	7,5X132	8,35-8,50	3,90-4,20	7,30-7,60	2,30 +/- 10%	T 30
1770201400	7,5X152	8,35-8,50	3,90-4,20	7,30-7,60	2,30 +/- 10%	T 30
1770201500	7,5X182	8,35-8,50	3,90-4,20	7,30-7,60	2,30 +/- 10%	T 30

## Finishing plugs for screw Torx T30



- Screw covers plastic usable as a finish for all screws with Torx T30, in particular screws by type cement our codes 177 02, used for the fastening of windows and doors.
- Available in the shades most used, the diameter of the cap of 16.6 mm unable to cover also the heads TSP in addition to cylindrical ones.

Code	Desc.	Color	Ø testa mm
219TP00500	500	White	16,6
219TP00510	510	Grey	16,6
219TP00520	520	Black	16,6
219TP00530	530	Ocher	16,6
219TP00540	540	Light brown	16,6
219TP00550	550	Dark brown	16,6



## Ancoraggi a vite per calcestruzzo

- Viti per calcestruzzo con testa: esagonale, tonda e svasata, per fissaggi medio-pesanti.
- **Settori di utilizzo:** carpenteria leggera e pesante.
- Ideale per il fissaggio su calcestruzzo, calcestruzzo fessurato, cemento armato, di : corrimani, mensole, piastre, scale, macchinari, cancelli, profili metallici, sottostrutture di legno e metallo.
- **Vantaggi:** ancorante di nuova concezione, con falsa rondella e zigrinatura autobloccante sottotesta.
- Con l'apposito tappo sicurezza le viti t.t. e t.p.s. garantiscono l'invulnerabilità del fissaggio.
- Grazie alla doppia filettatura su tutta la lunghezza della vite, consente grandi capacità di carico e massima velocità di applicazione.

### Vite testa esagonale



**CARATTERISTICHE TECNICHE**

CODICE	ESTRAZIONE-CARICO RACCOMANDATO daN	TAGLIO-CARICO RACCOMANDATO daN
177 02 03000	1,9	8,7
177 02 03100	2,8	5,7
177 02 03200	2,3	7,8
177 02 03300	3,9	7,8
177 02 03400	3,9	7,8
177 02 03500	3,9	7,8

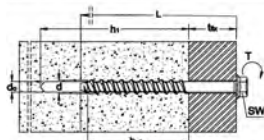

**ISTRUZIONI DI MONTAGGIO**

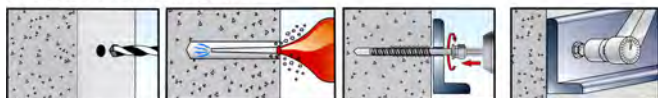

Code	Desc.	Ø foro (do) mm	Ø vite (d)	Screw leng. (L) mm	Anch. dep. (hef) mm	Spes. max fissabile (T fix)	Hole depth (h1) mm	Wrench (sw) mm	Tightening torque (T) Nm
1770203000	7,8X60/TE	6	7,8	60	45	10	65	10	25
1770203100	7,8X80/TE	6	7,8	80	55	20	75	10	25
1770203200	10X60/TE	8	10	60	45	10	70	13	50
1770203300	10X80/TE	8	10	80	65	10	90	13	50
1770203400	10X100/TE	8	10	100	65	30	90	13	50
1770203500	10X120/TE	8	10	120	65	50	90	13	50



## Vite testa tonda



### CARATTERISTICHE TECNICHE

CODICE	ESTRAZIONE-CARICO RACCOMANDATO daN	TAGLIO-CARICO RACCOMANDATO daN
177 02 03600	1,9	5,7
177 02 03700	2,8	5,7
177 02 03800	2,3	7,8
177 02 03900	3,9	7,8
177 02 04000	3,9	7,8
177 02 04100	3,9	7,8

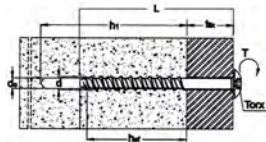

### ISTRUZIONI DI MONTAGGIO

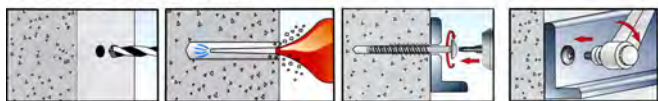

5

Code	Desc.	Ø foro (do) mm	Ø vite (d) mm	Screw leng. (L) mm	Anch. dep. (hef) mm	Spes. max fissabile (T fix)	Hole depth (h1) mm	Tightening torque (T) Nm	Imprint Torx
1770203600	7,8X60/TT	6	7,8	60	45	10	65	25	T30
1770203700	7,8X80/TT	6	7,8	80	55	20	75	25	T30
1770203800	10X60/TT	8	10	60	47,5	10	70	50	T40
1770203900	10X80/TT	8	10	80	65	10	90	50	T40

## Vite testa svasata piana



### CARATTERISTICHE TECNICHE

CODICE	ESTRAZIONE-CARICO RACCOMANDATO daN	TAGLIO-CARICO RACCOMANDATO daN
177 02 04500	2,8	5,7
177 02 04600	2,8	5,7
177 02 04700	3,9	7,8
177 02 04800	3,9	7,8
177 02 04900	3,9	7,8

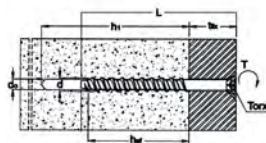

### ISTRUZIONI DI MONTAGGIO

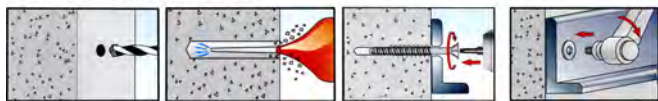

Code	Desc.	Ø foro (do) mm	Ø vite (d) mm	Screw leng. (L) mm	Anch. dep. (hef) mm	Hole depth (h1) mm	Tightening torque (T) Nm	Imprint Torx	Spes. max fissabile (T fix)
1770204500	7,8X70/TSP	6	7,8	70	55	75	25	T30	10
1770204600	7,8X80/TSP	6	7,8	80	55	75	25	T30	20
1770204800	10X100/TSP	8	10	100	65	90	50	T40	30

## Tappo di sicurezza



- Tappo di sicurezza per ancoraggi a vite per calcestruzzo con inserto torx.
- Di materiale deformabile a pressione.
- Vantaggi: la deformazione per percussione del tappo, consente la copertura totale dell'impronta torx, rendendo inviolabile la vite.

Code	Desc.	For track
1770205000	TP30	T30
1770205100	TP40	T40

# Viti per calcestruzzo con filetto metrico maschio e femmina

5

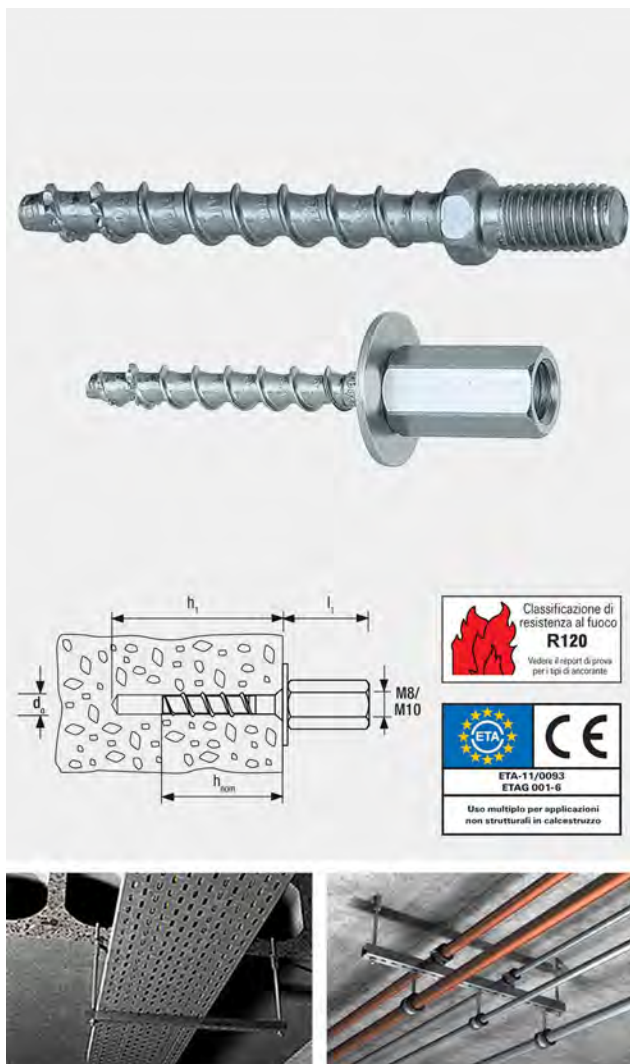

## INSTALLAZIONE DI VITI PER CALCESTRUZZO (UTILIZZARE UN AVVITATORE A IMPULSI A BATTERIA O ELETTRICO)

Vite per calcestruzzo FBS 6	Coppia di serraggio nominale raccomandata dell'avvitatore a impulsi <sup>1)</sup> [Nm]	Coppia di serraggio massima dell'avvitatore a impulsi <sup>1)</sup> [Nm]
FBS 6	100	150

<sup>1)</sup> I valori si applicano a calcestruzzo con classe di resistenza di 40 N/mm<sup>2</sup> circa, per altre classi di resistenza del calcestruzzo i valori possono essere diversi. La conversione da valore nominale a valore effettivo della coppia di serraggio varia da macchina a macchina - è necessario sempre utilizzare il controllo della coppia.

## CARICHI

### Vite per calcestruzzo FBS 6

Carichi ammissibili massimi per un ancorante singolo<sup>1)</sup> per uso multiplo in applicazioni non strutturali in calcestruzzo da C20/25 a C50/60. Per la progettazione deve essere consultata la Valutazione Tecnica Europea ETA - 11/0093.

Tipo	Profondità di ancoraggio ridotta $h_{nom, red}$ [mm]	Profondità di ancoraggio standard $h_{nom, sta}$ [mm]	Spessore minimo supporto $h_{min}$ [mm]	Coppia di serraggio $T_{inst, max}$ [Nm]	Calcestruzzo fessurato e non fessurato			
					Carico ammissibile a trazione $N_{perm}^{2)}$ [kN]	Carico ammissibile a taglio $V_{perm}^{2)}$ [kN]	Interasse min $s_{min}^{2)}$ [mm]	Distanza dal bordo min $c_{min}^{2)}$ [mm]
FBS 6	35	-	80	≤ 10	0,6	2,4	35	35
FBS 6	-	55	100	≤ 10	3,6	3,3	40	40

<sup>1)</sup> Nel calcolo del carico ammissibile sono stati considerati i coefficienti parziali di sicurezza per la resistenza dei materiali, come indicato nel benestare, e il coefficiente parziale di sicurezza per le azioni  $\gamma_L = 1,4$ . Un ancorante è considerato singolo quando l'interasse  $s \geq 3 \times h_{ef}$  e la distanza dal bordo  $c \geq 1,5 \times h_{ef}$ . Per maggiori dettagli consultare la valutazione.

<sup>2)</sup> È possibile utilizzare interassi e distanze dal bordo minimi solo riducendo il carico ammissibile. Per combinazioni di azioni di trazione, di taglio e momenti flettenti, così come per interassi e/o distanze dal bordo ridotti (ancoranti in gruppo) consultare la valutazione.

Code	Desc.	Ø hole mm	Profondità minima foro mm	Sporgenza mm	Chiave di serraggio	Versione
1770207060	FBS 6X35 M8/19	6	45	19	10	filettatura maschio M8
1770207070	FBS 6X55 M8/19	6	65	19	10	filettatura maschio M8
1770207080	FBS 6X35 M8/M10I	6	45	26,5	13	doppia filettatura femmina M8-M10
1770207090	FBS 6X55 M8/M10I	6	65	26,5	13	doppia filettatura femmina M8-M10

## Ancorante a elevate prestazioni in acciaio inox A2 (AISI 304)



Carichi max ammissibili in daN per applicazioni in calcestruzzo di classe R <sub>28</sub> 25 N/mm <sup>2</sup>				
ANCORANTE	Ø 6	Ø 8	Ø 10	Ø 12
(1 da N ≈ 1 Kg)	230	360	480	870

**CONDIZIONI DI INSTALLAZIONE**

Interasse critica tra ancoranti a (mm)	180	190	220	300
Distanza critica dal bordo a1 (mm)	70	80	100	120
Interasse minimo tra ancoranti a min. (mm)	90	95	110	150
Distanza minima dal bordo a1 min. (mm)	35	40	50	60
Spessore minimo supporto S (mm)	100	100	100	150
Coppia serraggio Nm	8	20	45	65

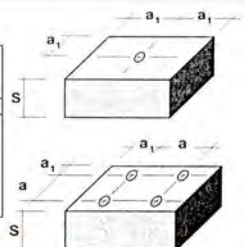

**SEQUENZA DI MONTAGGIO**

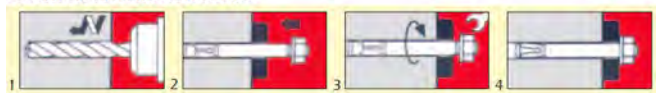

**IL RIQUADRO RIPORTA I CARICHI AMMISSIBILI IN daN IN CONSIDERAZIONE DI:**

SOLLECITAZIONI APPLICATE IN QUALSIASI DIREZIONE (TRAZIONE ASSIALE, TAGLIO, TIRO INCLINATO)  
 ANCORANTI INSTALLATI CON DISTANZE DAL BORDO E DISTANZE TRA ANCORANTI UGUALI O SUPERIORI A QUELLE CRITICHE. PER DISTANZE INFERIORI A QUELLE CRITICHE E' NECESSARIO RIDURRE I CARICHI AMMISSIBILI  
 SPESSORI DI SUPPORTO UGUALI O MAGGIORI A QUELLI RIPORTATI

Code	Desc. ØxL body	Spes. max fissaggio mm	Ø hole mm
155A200050	6x65/EPX	10	6
155A200100	8x55/EPX	5	8
155A200150	8x75/EPX	10	8
155A200200	8x90/EPX	25	8
155A200300	10x65/EPX	5	10
155A200350	10x90/EPX	20	10
155A200400	10x120/EPX	50	10
155A200500	12x110/EPX	20	12
155A200550	12x145/EPX	50	12





## Ancorante chimico in fiala



- Sistema di fissaggio chimico composto da resina poliestere contenuta in una doppia fiala di vetro, insieme ad un catalizzatore. Utilizzabile per fissare barre filettate, fissaggi sotto rotaia di cancelli scorrevoli, ringhiere, inferriate, barriere stradali, fissaggio di pali e segnaletica stradale, ecc.
- Dotate di certificazione ETA opzione 7 per l'utilizzo su calcestruzzo non fessurato.
- L'utilizzo delle fiale velocizza la posa, elimina gli sprechi di prodotto, permette fissaggi in vicinanza dei bordi del supporto e non obbliga all'uso di pistole o altri applicatori. Una volta effettuato e pulito il foro si inserisce la fiala in qualsiasi direzione, inserendo poi la barra filettata con rotopercolazione. I due componenti del contenuto si mischieranno perfettamente garantendo una presa veloce ed ottimale.
- La particolare formulazione della resina ne permette l'utilizzo anche all'interno di fori umidi o allagati senza nessun problema. Utilizzare barre filettate tagliate a 45° sulla punta. Stoccare a temperature tra i +5°C ed i +25°C. Il prodotto correttamente stoccato ha una durata di 24 mesi dalla data di produzione.

5

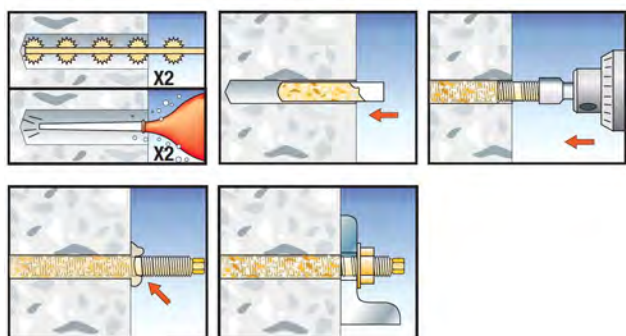
**Parametri di temperatura e manipolazione**

Temperatura calcestruzzo °C	Tempo minimo di indurimento in calcestruzzo asciutto (minuti)	Tempo minimo di indurimento in calcestruzzo umido (minuti)
-5°C - 0°C	360	720
0°C - +5°C	180	360
+5°C - +10°C	90	180
+10°C - +20°C	40	80
>+20°C	20	40

**Dati tecnici per l'installazione**

			Ø 10 mm	Ø 12 mm	Ø 16 mm
Diametro foro	d 0	mm	12	14	18
Diametro massimo del foro sull'oggetto	d fix	mm	12	14	18
Profondità foro	h 0	mm	90	110	125
Spessore minimo del supporto	h min	mm	120	150	160
Coppia di serraggio	T inst	Nm	20	40	60
Interasse minimo	S min	mm	70	85	95
Distanza minima dal bordo	C min	mm	70	85	95

**Resistenza a trazione in KN su calcestruzzo non fessurato C20/25, pulizia standard (1 KN = 10 Kg)**

Diametro filettata	barra	M10	M12	M16
Resistenza KN		12	16	25

Code	Descr. Diam. x length	Ø hole mm	Hole depth mm
1550001330	10X85VF	12	90
1550001340	12X95VF	14	110
1550001350	16X95VF	18	125

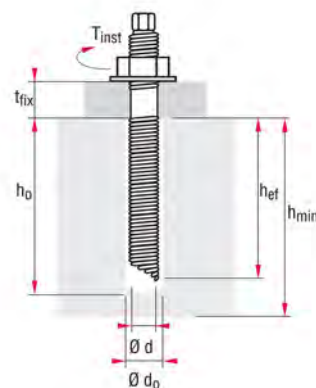

# Ancorante chimico poliestere CE



**NON TOSSICO  
ININFIAMMABILE**

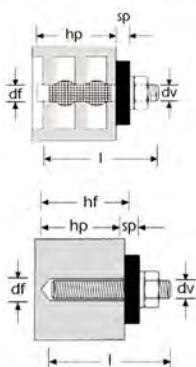

- Resina poliestere per ancoraggi chimici esente da stirene, per fissaggi ad elevate prestazioni e lunghissima durata nel tempo su ogni tipo di muratura.
- Dotata di valutazioni tecniche europee ETAG 001-05 Opzione 7 M8-M16 per l'utilizzo su calcestruzzo non fessurato ed ETAG 029 Categoria: c, w/d, M10 Elementi in acciaio con riferimento a tabella 2, Allegato 5 del ETA-11/0511 per l'utilizzo su murature e pareti forate.
- Indicata per fissaggi su: calcestruzzo, pietra naturale, legno, mattone pieno, marmo, mattone forato, mattone semipieno, blocchi di cemento vuoti. Fissaggi di tipo medio pesanti, carpenteria metallica leggera, impiantistica leggera, pannelli solari e termici, parapetti, serramenti, ringhiere, cancelli e porte blindate, cardini, tende da sole, antenne paraboliche, ecc.
- L'assenza di stirene la rende a basso odore e non nociva, resiste alla corrosione chimica e alle aggressioni di sostanze acide e basiche. Idelae per applicazione in prossimità dei bordi, ridotta tensione sul materiale di base, ridotto ritiro in fase di essiccazione.
- Cartuccia coassiale da 410 ml dotata di due miscelatori di ricambio, facilmente richiudibile e riutilizzabile.

**SEQUENZA DI MONTAGGIO MATERIALE FORATO**



Forare con diametro e profondità indicati in tabella



Iniettare la resina in superficie, seguendo le istruzioni di posa

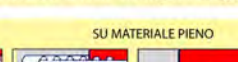

Inserire la barra di fissaggio facendola ruotare lentamente

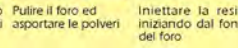

A resina indurita, trascorso il tempo di polimerizzazione eseguire il serraggio

l = lunghezza barra  
df = diametro foratura  
hf = prof. foratura  
hp = prof. di posa  
sp = spessore fissabile  
C = coppia di serraggio  
dv = diametro filetto

l = lunghezza barra  
df = diametro foratura  
hp = prof. di posa  
dv = filetto  
sp = spessore fissabile  
C = coppia di serraggio  
hf = prof. min. foratura

**SU MATERIALE PIENO**



Forare con diametro e profondità indicati in tabella



Pulire il foro ed asportare le polveri



Iniettare la resina iniziando dal fondo del foro

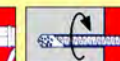

Inserire la barra di fissaggio facendola ruotare lentamente



A resina indurita, trascorso il tempo di polimerizzazione eseguire il serraggio

**Tempi minimi di indurimento**

Temperatura supporto	Tempo di manipolazione	Indurimento su supporto asciutto	Indurimento su supporto umido
-10°C*	50 minuti	240 minuti	480 minuti
-5°C*	40 minuti	180 minuti	360 minuti
+5°C	20 minuti	90 minuti	180 minuti
+15°C	9 minuti	60 minuti	120 minuti
+25°C	5 minuti	30 minuti	60 minuti
+35°C	3 minuti	20 minuti	40 minuti

\* Con temperatura della resina di almeno +20°C.

**Dati tecnici caratteristici di fissaggio su calcestruzzo 25 N/mm<sup>2</sup>, cartuccia da 410 ml**

Diametro ancorante mm	Diametro foro mm	Profondità foro mm	Resistenza estrazione Kn	Numero di fissaggi (foro riempito 2/3)
8	10	90	19,00	80
10	12	90	26,30	45
12	14	110	36,29	30
16	18	125	52,15	15
20	24	150	82,35	6



ETAG 029 Categoria:c,w/d Ø M8, M10, M12  
Elementi in acciaio con riferimento a tabella 2  
Allegato 5 del ETA-11/0511  
Uso su muratura e pareti forate

Code	Desc.	Content ml	N. Mixer
1550005100	33/400	410	2

# Polyester chemical anchor for cold temperatures



ETAG 001-05  
M8-M16  
per uso su calcestruzzo  
non fessurato

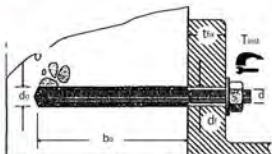

- Anchor polyester resin suitable for fixing of heavy loads of concrete, marble, stone, rock and all solid materials, materials and semi-tubular rivets drilled through the use of special bushing, concrete blocks empty, etc., Up to -10 ° C.
- Suitable for the construction, metal structural work, carpentry in wood, hardware equipment and facilities, in the areas of electrical and plumbing hardware, hardware lifelines, guard rails, railings, solar panels, satellite dishes, awnings, etc.
- The special formulation winter allows its use even in extreme weather conditions with short curing times. The product is also used by those who, even with mild outside temperatures, want a product with drying times and laying very low. Workloads certified by the "Building Research Institute" in London.
- Formulation styrene low odor, not even annoying indoors. Perfectly resists corrosion and chemical attack from acids and bases. It also applies to neighboring edges, no tension on fastening materials. Reduced polymerization shrinkage.
- Coaxial cartridge supplied with a mixer, applicable with our guns for chemical anchoring.

SEQUENZA DI MONTAGGIO SU MURATURA FORATA



1 Forare con diametro e profondità indicati in tabella. 2 Inserire la bussola retinata nel foro. 3 Far fuoriuscire circa 10 cm di materiale dal contenitore prima di cominciare. Inserire il miscelatore nel foro ed estrarre il composto partendo dal fondo fino a raggiungere circa la metà della profondità. 4 Applicazione. 5 Inserire la barra o il supporto da fissare con movimento rotatorio fino a fondo del foro. 5 Osservare il tempo d'indurimento prima di concludere il serraggio.

SEQUENZA DI MONTAGGIO SU MURATURA PIENA

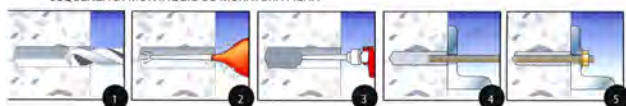

1 Forare con diametro e profondità indicati in tabella. 2 Pulire il foro con l'ausilio di una pompetta manuale o scovolini. 3 Far fuoriuscire circa 10 cm di materiale dal contenitore prima di cominciare. Inserire il miscelatore nel foro ed estrarre il composto partendo dal fondo fino a raggiungere circa la metà della profondità. 4 Applicazione. 5 Inserire la barra o il supporto da fissare con movimento rotatorio fino a fondo del foro. 5 Osservare il tempo d'indurimento prima di concludere il serraggio.

**CARATTERISTICHE TECNICHE**

Diametro della barra d mm	Foro su calcestruzzo do mm	Foro su supporto df mm	Profondità di posa bo mm	Coppia di serraggio Nm calcestruzzo/muratura
M8	10	9	80	11/5
M10	12	11	90	22/17
M12	14	13	110	38/28
M16	18	17	125	95/75
M20	24	22	170	170/-
M24	28	26	210	260/-
M30	35	33	280	480/-

**Ulteriori proprietà del prodotto**

	N/mm <sup>2</sup>	Metodo di prova
Resistenza a compressione	53,55	(ASTM 695)
Resistenza a flessione	24,08	(ASTM 795)
Modulo di flessione	2927,67	-
Resistenza a trazione	12,48	(ASTM 638)
Modulo elastico	9651,33	-
Contenuto VOC	0,143%	2,31 g/L

**Parametri di installazione su calcestruzzo**

Dimensioni della barra mm	Calcestruzzo, f ck cube=25N/mm <sup>2</sup> (C20/25)								
	Resistenza caratteristica (kN)		Resistenza di progetto (kN)		Carico consigliato (kN)		Distanza dal bordo (mm)		Interasse (mm)
	Trazione	Taglio	Trazione	Taglio	Trazione	Taglio	Trazione	Taglio	
M8	19,0	9,5	12,7	7,6	9,0	5,4	80,0	80,0	160
M10	28,5	15,1	13,1	12,1	9,3	8,6	100,0	90,0	200
M12	40,5	21,9	18,7	17,5	13,3	12,5	120,0	110,0	240
M16	69,2	40,8	32,0	32,7	22,8	23,3	160,0	125,0	320
M20	89,9	63,7	41,6	51,0	29,7	36,4	200,0	180,0	400
M24	112,6	91,8	52,1	73,4	37,2	52,4	240,0	220,0	480
M30							265,0	280,0	525

Code	Desc.	Content ml
1550010330	91/410	410



# Ancorante chimico epossiacrilato CE



- Resina epossiacrilato per ancoraggi chimici esente da stirene, per ancoraggi ad elevatissime prestazioni e lunghissima durata nel tempo su ogni tipo di muratura.
- Dotata di valutazioni tecniche europee ETAG 001-05 Opzione 7 M8-M16 per l'utilizzo su calcestruzzo non fessurato ed ETAG 029 Categoria: c, w/d, M10 Elementi in acciaio con riferimento a tabella 2, Allegato 5 del ETA-11/0511 per l'utilizzo su murature e pareti forate.
- Indicata per fissaggi su: calcestruzzo, pietra naturale, legno, mattone pieno, marmo, mattone forato, mattone semipieno, blocchi di cemento vuoti. Fissaggi di tipo medio pesanti, carpenteria metallica leggera, impiantistica leggera, pannelli solari e termici, parapetti, serramenti, ringhiere, cancelli e porte blindate, cardini, tende da sole, antenne paraboliche, ecc.
- L'assenza di stirene la rende a basso odore e non nociva, resiste alla corrosione chimica e alle aggressioni di sostanze acide e basiche. Ideale per applicazione in prossimità dei bordi, ridotta tensione sul materiale di base, ridotto ritiro in fase di essiccazione.
- Cartuccia coassiale da 410 ml dotata di due miscelatori di ricambio, facilmente richiudibile e riutilizzabile. Cartuccia da 300 ml utilizzabile con le normali pistole per silicone.

5

**NON TOSSICO  
ININFIAMMABILE**      **IDEALE PER UTILIZZI  
ALL'ESTERNO**

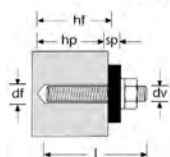

l = lunghezza barra      sp = spessore fissabile  
df = diametro foratura      C = coppia di serraggio  
hp = prof. di posa      hf = prof. min. foratura  
dv = filetto



**Tempi minimi di indurimento**

Temperatura supporto	Tempo di manipolazione	Indurimento su supporto asciutto	Indurimento su supporto umido
-10°C*	50 minuti	240 minuti	480 minuti
-5°C*	40 minuti	180 minuti	360 minuti
+5°C	20 minuti	90 minuti	180 minuti
+15°C	9 minuti	60 minuti	120 minuti
+25°C	5 minuti	30 minuti	60 minuti
+35°C	3 minuti	20 minuti	40 minuti

\* Con temperatura della resina di almeno +20°C.

**Dati tecnici caratteristici di fissaggio su calcestruzzo 25 N/mm<sup>2</sup>, cartuccia da 410 ml**

Diametro ancorante mm	Diametro foro mm	Profondità foro mm	Resistenza estrazione Kn	Numero di fissaggi (foro riempito 2/3)
8	10	90	19,00	80
10	12	90	30,20	45
12	14	110	43,13	30
16	18	125	62,46	15
20	24	150	96,13	6



ETAG 001-05 Opzione 7  
M8-M16  
per calcestruzzo non fessurato  
pending



ETAG 029 Categoria:c,w/d misura M10  
Elementi in acciaio con riferimento a tabella 2  
Allegato 5 del ETA-11/0031  
Uso su muratura e pareti forate

Code	Desc.	Content ml	N. Mixer
1550005300	34/410	410	2
1550005400	34/300	300	2

# Ancorante chimico vinilestere senza stirene CERTIFICATO



ETAG 01-01 TR023  
Barre post-installate da  
Ø 8 a Ø 16 mm



ETAG 001-05 Opzione 7  
M8-M24 / Ferri da ripresa da Ø 8 a 25 mm  
Per calcestruzzo non fessurato



ETAG 001-05 Opzione 1  
M12-M16 / Barre filettate  
Per calcestruzzo fessurato

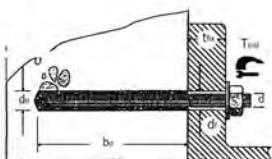

SEQUENZA DI MONTAGGIO SU MURATURA FORATA



1 Forare con diametro e profondità indicati in tabella. 2 Inserire la bussola retinata nel foro. 3 Far fuoriuscire circa 10 cm di materiale dal contenitore prima di cominciare. Inserire il miscelatore nel foro ed estrarre il composto partendo dal fondo fino a raggiungere circa la metà della profondità. 4 Applicazione. 5 Inserire la barra o il supporto da fissare con movimento rotatorio fino al fondo del foro. 6 Osservare il tempo d'indurimento prima di concludere il serraggio.

SEQUENZA DI MONTAGGIO SU MURATURA PIENA



1 Forare con diametro e profondità indicati in tabella. 2 Pulire il foro con l'ausilio di una pompetta manuale o scovolini. 3 Far fuoriuscire circa 10 cm di materiale dal contenitore prima di cominciare. Inserire il miscelatore nel foro ed estrarre il composto partendo dal fondo fino a raggiungere circa la metà della profondità. 4 Applicazione. 5 Inserire la barra o il supporto da fissare con movimento rotatorio fino al fondo del foro. 6 Osservare il tempo d'indurimento prima di concludere il serraggio.

CARATTERISTICHE TECNICHE

Dimensioni della barra mm d	Foro su calcestruzzo mm do	Foro su supporto mm df	Profondità di posa mm bo	Coppia di serraggio raccoman. (Nm) calcestruzzo (Tinst)
M8	10	9	80	11
M10	12	11	90	22
M12	14	13	110	38
M16	18	17	125	95
M20	24	22	170	170
M24	28	26	210	260
M30	35	33	280	480

TEMPO DI INDURIMENTO

Temperatura materiale C°	Tempo di manipolazione min.	Tempo di messa in opera min.
35	3	20
25	6	20
15	7	20
5	20	30
-5	50	90

PARAMETRI DI INSTALLAZIONE SU CALCESTRUZZO

Dimensioni della barra	Calcestruzzo = 25 N/mm <sup>2</sup> (C20/25)									
	Resistenza caratteristica (kN)		Resistenza Progetto (kN)		Carichi consigliati (kN)		Distanza dal bordo (mm)		Interasse (mm)	
	Trazione	Taglio	Trazione	Taglio	Trazione	Taglio	Trazione	Taglio	Trazione	Taglio
M8	22,2	10,1	10,2	8,1	7,3	5,8	80	100	100	
M10	36,6	15,6	18,1	12,5	13,0	8,9	90	130	130	
M12	50,5	23,1	24,7	18,5	17,7	13,2	110	150	150	
M16	79,0	41,8	38,8	33,5	27,8	23,9	130	170	170	
M20	101,3	66,8	49,7	53,4	35,5	38,2	150	190	210	
M24	136,6	95,7	64,3	76,6	46,0	54,7	190	240	240	
M30	237,1	123,0	115,3	97,0	82,4	69,3	300	350	350	

Code	Desc.	Content ml	N. Mixer
1550010250	90/400	400	2



## Accessori per ancoraggi chimici: miscelatori



- Miscelatore di ricambio per cartucce chimiche ns. cod. 155 00 05100-33/380 - cod. 155 00 05300-34/380 - cod. 155 00 05400-34/280.

Code	Description
1550001750	Miscelatore

## Bussola filettata internamente per fissaggi chimici



Code	Desc. Ø X L mm	Ø hole mm	Utilization
1550001460	12X80/BT	14	Access. e barre M8
1550001470	14X80/BT	16	Access. e barre M10
1550001480	16X80/BT	18	Access. e barre M12

## Barre filettate per ancoraggi chimici



- Barra filettata in acciaio 5.8 zincato min 5 µ completa di dado e rondella

Code	Desc. Ø X L mm	Ø hole mm	Model
1550001500	8X110/BD	10	Completa di dado e rondella
1550001510	10X110/BD	12	Completa di dado e rondella
1550001520	10X160/BD	12	Completa di dado e rondella
1550001530	12X115/BD	14	Completa di dado e rondella
1550001540	16X190/BD	18	Completa di dado e rondella

## Forged hook with nut and washer



- Hook Forged yellow zinc plated 5 microns with hexagon nut and washer.

Code	Desc.	Diameter threading mm	Length thread mm	P mm
1550001550	8X60/G	8	60	10
1550001560	10X70/G	10	72	12,5
1550001570	12x90/G	12	92	17,5

## Eyelet printed with nut and washer



- Eyelet Forged yellow zinc plated 5 microns with hexagon nut and washer.

Code	Desc.	Diameter threading mm	Length thread mm	Internal diam. eyelet mm
1550001580	8x60/O	8	60	11
1550001590	10x70/O	10	73	14,5
1550001600	12x90/O	12	92	17,0

5

## Bussola retinata per fissaggi chimici



- Bussola in plastica indispensabile per effettuare i fissaggi con l'ancorante in resina sulle superfici in muratura forata.
- L'uso delle bussole permette un dosaggio ottimale della resina ed un ottimo centramento dell'accessorio montato.

Code	Desc. ØxL body	Ø hole mm	Utilization
1550001410	12X60/BR mm	12	Acess. e barre M6-M8
1550001420	12X80/BR mm	12	Acess. e barre M6-M8
1550001430	15X85/BR mm	15	Acess. e barre M10
1550001440	15X130/BR mm	15	Acess. e barre M10
1550001450	20X85/BR mm	20	Acess. e barre M12

## Bussola retinata a calza per fissaggi chimici

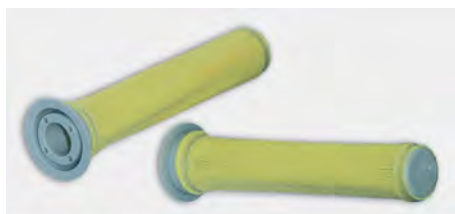

- Bussole retinate con corpo in rete altamente flessibile, per ancoraggi chimici su murature vuote.
- L'utilizzo di queste bussole, permette una distribuzione ottimale della resina ed un perfetto centraggio della barra filettata o dell'accessorio montato.

SEQUENZA DI MONTAGGIO

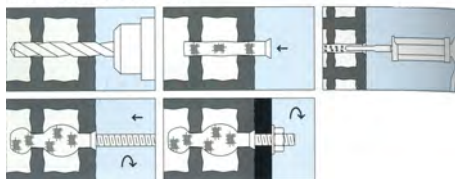

Code	Desc.	Ø hole mm	Utilization
1550008250	16X85/R	16	Acess. e barre M8
1550008260	18X85/R	18	Acess. e barre M10
1550008270	20X85/R	20	Acess. e barre M12

## Bussola a rete in acciaio per fissaggi chimici

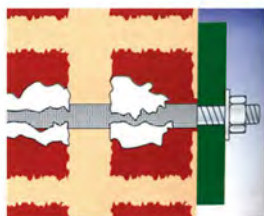
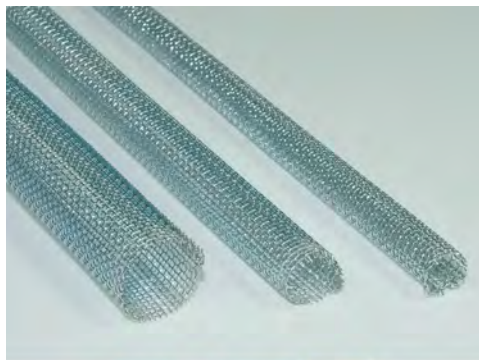

Code	Desc.	Measure	For Rods	Ø internal	Ø hole mm
1550009400	12/BA	12X1000	M8	9,5	12
1550009410	16/BA	16X1000	M10	12,5	16
1550009420	22/BA	22X1000	M16	18,5	22

5

## A hand pump cleaning Holes



- Practical and comfortable for the cleaning of the hole.
- Plastic body with straw rubber.
- Plunger in wood.
- Light and comfortable to use, practical-mind indestructible.

Code	Description	Diameter x length Mm.
1550001360	Pump	80x300

## Scovolino

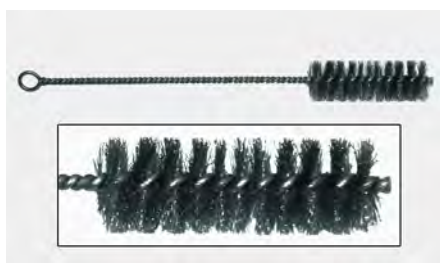

- Diam. 14x20 cm

Code	Desc.
1550010300	14X20

## Pistola a batteria per ancorante chimico 7,4V Li-Ion



- Pistola a batteria per cartucce coassiali di ancoranti chimici da 380-410 ml, compatta, leggera e maneggevole, dotata di grande forza di spinta e regolazione della velocità di estrusione.
- Indispensabile per effettuare fissaggi in serie veloci e senza sforzi, indicata per tutti i settori dell'artigianato e dell'industria che utilizzano fissaggi chimici.
- Forma ergonomica e bilanciata, costruita in robusto materiale antiurto, dotata di regolazione elettronica della velocità di estrusione facilmente raggiungibile durante l'uso. Sistema di sgancio automatico all'arresto per non far fuoriuscire il prodotto, pulsante di sicurezza contro l'avvio involontario.
- Fornita in valigetta plastica per il trasporto, dotazione di serie: 1 batteria agli ioni di litio ed un caricabatterie per corrente di rete 220 Volts. Massima forza di spinta 200 Kg. Massima velocità: 6,9 mm/sec. Peso: 1,35 Kg.

5

Code	Desc.
4170016080	380CTX

Spare Parts		
Article	Code	Desc.
Batteria di ricambio	417RC12590	1070/B
Caricabatterie	417RC12595	1070/R

## Pistola coassiale per ancorante chimico



Code	Desc.	Max thrust
1550001700	250	250 Kg

## Fixing kit chemical briefcase



- Complete kit for anchoring with chemical resins, in practical case shockproof.
- The kit includes: N° 3 400 ml cartridges of polyester anchoring styrene our code: 155 00 05100-33/380; N° 1 gun for coaxial cartridges of 400 ml, our code: 155 00 01700-250; N° 6 mixers cartridges our code 155 00 01750; N° 1 pump for cleaning holes our code 155 00 01360; N° 10 compasses screened plastic 15x85mm. Our article 155 00 01430-15x85 / br; N° 3 metal brushes to clean the hole diameter 14x20cm our code 155 00 10300; 20x30 cm diameter our code 155 0010305; 28x30 cm diameter our code 155 00 10310.
- Size carrying case 49.5 cm x 10.5 x 36h.

Code	Description
1550001320	Kit

Spare Parts			
Article	Code	Description	Photo
Chemical anchor styrene free polyester	1550005100	33/380	A
Coaxial gun for chemical anchor	1550001700	250	B
Mixer cartridge	1550001750	-	C
hand pump	1550001360	-	D
screened bush	1550001430	15X85/BR	E



## Pistola Sparachiodi a Gas C-40



- utensile ideale per fissaggi su acciaio, cemento, calcestruzzo, mattoni forati, legno ed altri materiali. Fornisce un fissaggio facile e rapido.
- Caricatore da 42 chiodi.
- Fissaggio del chiodo a filo sul muro.
- Punta balistica che permette una migliore penetrazione sul materiale da forare.
- Bilanciamento eccellente.
- Valigia completa di : 1 pistola sparachiodi, 1 caricabatteria, 2 batterie, 1 trasformatore, 2 inserti auricolari, 1 occhiale di protezione, istruzioni d'uso.

Code	Desc.
1550008450	C/40

Tecnical Features	
Weight	3,7 kg
Battery autonomy 6V	3000 colpi
Gas cylinder autonomy	1000 colpi
Charger capacity	42 chiodi
Velocità esecuzione	3 chiodi al secondo

CHIODO	USO RACCOMANDATO
13	Adatto per acciaio di spessore compreso tra 3 -6 mm
17	Cemento prefabbricato
19	Cemento duro >250Kg/cm <sup>3</sup>
25	Cemento normale 200 - 250 Kg/cm <sup>3</sup>
	Legno + cemento
	Acciaio (max 3 mm) + cemento
	Blocchi di cemento
32	Cemento leggero < 250 Kg/cm <sup>3</sup>
	Legno + cemento
	Acciaio (max 3mm) + cemento
38	Legno + legno

Spare Parts		
Article	Code	Description
BATTERIA	1550008460	39/B
CARICA BATTERIA	1550008470	39/C
TRASFORMATORE	1550008480	39/T

## Chiodi con bombola a gas



- Chiodi in acciaio temprato zincati.
- Diametro testa 6 mm.
- Confezione da 1000 chiodi e bomboletta gas.

Code	Desc.	Ø Gambo chiodo/mm	Nail length
1550008500	40/13	2,6	13
1550008510	40/17	2,6	17
1550008520	40/19	2,6	19
1550008530	40/25	2,6	25
1550008540	40/32	2,6	32
1550008550	40/38	2,6	38

## Bombola a gas



- **CONDIZIONI D'USO:** conservare la confezione a temperatura non superiore a 49°C. Tenere lontano da fonti di calore scintille o fiamme libere.

Code	Desc.	Content ml
1550008560	40/B	80ml

## Bandella perforata metallica



- Banda metallica multiuso preformata e perforata avvolta in rotoli da 10 mt.
- Disponibile in acciaio zincato galvanicamente.

Code	Desc.	Dim. widthxspe.mm	Diam. int. hole mm	Interaxis mm	Material
1550003600	23-AC	17x0.8	6,95	20	Acciaio zinc.

## Reinforced bandage with multiple holes



- Bandella rinforzata con piu' fori in acciaio zincato.
- **Settore di utilizzo:** impiantisti termoidraulici, impiantisti elettrici, manutentori.
- Adatta per lavorare con il sistema di fissaggio Steelfix.
- **Vantaggi:** idonea per sorreggere tubazioni sospese, oltre al fissaggio verticale e a terra di fasci di tubi.

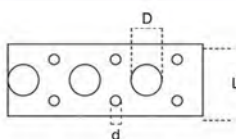

Code	Desc.	Belt width mm (L)	Leng. tape	Thickness mm	Holes diameter marginal mm(d)	Holes diameter mm (D)	Allowable load
1550009550	53/17	17	10 mt	0,8	3,5	7,5	60 kg
1550009560	53/25	25	10 mt	0,8	3,5	7,5	90 kg

## SISTEMA DI FISSAGGIO STEELFIX

SISTEMA DI FISSAGGIO DIRETTO, SENZA PREFORO, TRAMITE CHIODI IN ACCIAIO TEMPERATO. IL SISTEMA PIÙ SEMPLICE E RAPIDO PER IL FISSAGGIO DIRETTO DI TUBAZIONI SU MATERIALI EDILI IN OGNI SETTORE, ELETTRICO, IDRAULICO, CLIMATIZZAZIONE, ECC.

## Chiodatrice manuale Steelfix



- Chiodatrice a mano in acciaio da utensili antiscaglia, paramano in gomma anti vibrazioni, foro di fissaggio del chiodo sulla punta con molla di tenuta. Costruzione secondo le normative di sicurezza DIN 7255.
- Uso: applicare il chiodo della lunghezza desiderata sulla punta, appoggiare la punta del chiodo sul punto dove si vuole effettuare il fissaggio, percuotere la chiodatrice con una mazzetta minimo da 1,5 kg. fino ad appoggiare il collare del chiodo sul pezzo da

Code	Desc.
1550007970	35

## Chiodi in acciaio Steelfix

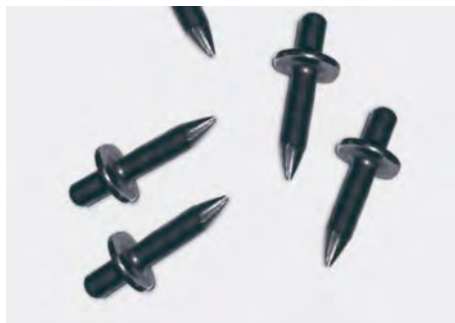

- Chiodi speciali in acciaio ad alto tenore di carbonio, temperati, per l'uso nella massima sicurezza e semplicità di applicazione.
- Esecuzione liscia, con collare di diametro 8 mm. Punta ad elevata penetrazione.
- Per applicazioni tramite chiodatrice manuale su ogni tipo di supporto in muratura (calcestruzzo, cemento armato, blocchi termici, ecc.).

Code	Desc.	Length Under Head mm
1550007950	FXP18	18
1550007960	FXP22	22

5

## Cavallotti singoli per Steelfix



- Staffe singole in acciaio elettrozincato, spessore 1,2 mm., con foro di fissaggio diametro 5 mm.
- Ideali per il fissaggio di tubazioni elettriche, idrauliche, cavi, su tutti i supporti edili tramite chiodi del sistema Steelfix, oppure tasselli di diametro 5 mm. sia a percussione sia di tipo tradizionale.

Code	Desc.	Measure PG	For pipes mm
1550008010	36/20	13,5	19-20
1550008020	36/22	16	21-22
1550008030	36/28	21	27-28

## Bandella preforata per Steelfix



- Bandella in acciaio per fissaggio di tubazioni elettriche ed idrauliche con il sistema Steelfix.
- Disponibile in versione zincata o ricoperta in materiale plastico.
- Spessore della bandella 1 mm., larghezza nastro metallico 12 mm., fori di diametro 5 mm., interasse fori di 10 mm., carico max 1300 N.

Code	Desc.	Model	Tape leng. m.
1550008200	38/Z	Bandella preforata zincata	10
1550008210	38/P	Bandella preforata plastificata	10

## Nastro di fissaggio in tessuto per steelfix



- Nastro in poliestere per fissaggio di tubazioni elettriche ed idrauliche con il sistema Steelfix.
- Alternativa al fissaggio con bandella forata, imputrescibile, indistruttibile, resistente alle temperature fino a +120°C.
- Non danneggia assolutamente le tubazioni fissate.
- Larghezza del nastro 15 mm., spessore 1 mm., carico max 3.000 N.

Code	Desc.	Tape leng. m.
1550008230	38/N	10

## Supporti per tubi in nylon ad incastro



- Cavallotti aperti per il supporto di tubi metrici isolanti rigidi.
- Applicazione rapida tramite l'utilizzo di tasselli leggeri.
- Possibile utilizzo con le guide in serie e l'accoppiamento tramite incastro a coda di rondine.
- Colore grigio RAL7035.



Code	Desc.	Ø Tubo mm	D mm
155TA04800	PT 15	16	15
155TA04810	PT 19	20	19
155TA04820	PT 24	25	24

## Fissaggi pesanti con collare per tubi



- In acciaio zincato bianco.
- Indicato per l'installazione a muro di tubi gas zincati e per tutte le tubazioni in generale.
- Composto da: collare pesante con dado saldato, vite di congiunzione, dado di registrazione e tassello in nylon diam 10mm.
- Estremamente robusto e resistente agli agenti atmosferici.
- Ideale per il fissaggio su calcestruzzo, pietra naturale, mattone pieno, mattone semipieno, mattone forato.

### CARATTERISTICHE TECNICHE

	3/8" pollici	1/2" pollici	3/4" pollici	1" pollici	1 1/4" pollici	1 1/2" pollici	2" pollici	2 1/2" pollici	3" pollici	4" pollici
<b>Fc</b> max carico di impiego - Kg	320	320	320	320	320	320	320	370	370	370
<b>Fc</b> carico di rottura - Kg	1050	1050	1050	1050	1050	1050	1050	1050	1050	1050
<b>Ft</b> max carico di impiego - Kg	50	50	50	50	50	50	50	50	50	50
<b>Ft</b> carico di rottura - Kg	450	450	450	450	450	450	450	450	450	450

Carico max di impiego: carico consigliato da non superare in condizioni di normale impiego su calcestruzzo C25/30.  
Carico di rottura: carico di rottura del collare su calcestruzzo C 25/30

Code	Desc.	Ø hole mm	Ø tubo	Dimensione vite diametro xL mm.	Collar width X thickness mm
1550003100	19-1	10	3/8"	M8 x 90	20 x 2,5
1550003110	19-2	10	1/2"	M8 x 90	20 x 2,5
1550003120	19-3	10	3/4"	M8 x 90	20 x 2,5
1550003130	19-4	10	1"	M8 x 90	20 x 2,5
1550003140	19-5	10	1.1/4"	M8 x 90	20 x 2,5
1550003150	19-6	10	1.1/2"	M8 x 90	20 x 2,5
1550003160	19-7	10	2"	M8 x 90	20 x 2,5
1550003170	19-8	10	2" 1/2	M 10 x 90	30 x 2,5

## Fissaggi leggeri con collare per tubi



Code	Desc.	Ø Tubo mm	Diam. Threaded Att.
1550003260	20 - 7	22	M 6
1550003270	20 - 8	24	M 6
1550003290	20 - 10	28	M 6
1550003300	20 - 11	32	M 6
1550003310	20 - 12	38	M 6
1550003320	20 - 13	42	M 6
1550003330	20 - 14	48	M 6
1550003340	20 - 15	50	M 6

**FORNITI SENZA VITE DI FISSAGGIO**

- Collari in acciaio zincato per il fissaggio di tubi leggeri.
- Chiusura del collare con doppia vite ed attacco con filettatura M6.

5

## Tassello in nylon per collari leggeri



- Tassello in nylon dim. 6x40 con vite a doppia filettatura.
- Fissaggio a percussione per montaggio collari leggeri.

Code	Desc.
1550003350	20/TV



## Ancorante in acciaio con golfare Ø 50 per ponteggi



- Ancoraggi speciali per ponteggi a collegamento diretto  $\varnothing$  50 mm.
- Il golfare permette il passaggio diretto del tubo da ponteggio all'interno dello stesso.
- Il sistema garantisce valori di resistenza e conformita' alle vigenti normative di sicurezza.
- Possibilita' di utilizzo su ogni tipo di supporto edile grazie al differente tipo di tassello.
- Riutilizzo del golfare grazie al corpo ancorante di ricambio.

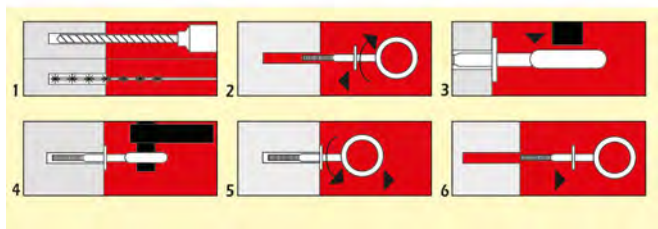

Code	Desc.	$\varnothing$ hole mm	Depth insertion	Anchoring type
1550003000	GP120	18	120	Acciaio
1550003020	GP1658	16	165	Nylon
1550003030	GPA	18	-	Acciaio (ricambio ancorante)
1550003040	GPN	16	-	Nylon (ricambio ancorante)

## Clips fissatubi a fascetta



- Clips a fascetta in poliammide 6.
- Colore grigio chiaro RAL 7035.
- **Campi di utilizzo:** elettricisti, termoidraulica.
- **Caratteristiche:** velocita' e praticita' nell'istallazione e nell' applicazioni di tubi idraulici ed elettrici.
- Sicurezza nel fissaggio. Una volta fissato il tubo, rimane saldo nella clips.
- Base asolata per favorire l'allineamento delle istallazioni.
- Da utilizzare con i tasselli Meccanocar:  
**tassello standard in nylon senza bordo e con bordo, con tassello universale in nylon senza bordo e con bordo, con tassello in nylon a 4 settori sx e con tassello in nylon fissaggio con percussione.**

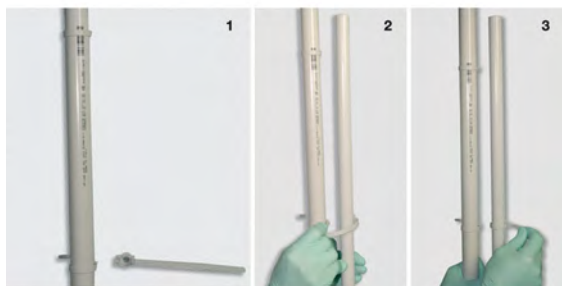

Code	Desc.	Attaching tubes diam. Mm.	Diameter fixing hole mm.	Recommended dowel Diam. mm.
155TA08410	35/8-32	8-32	5x8,5	6

## Collare isofonico con tassello

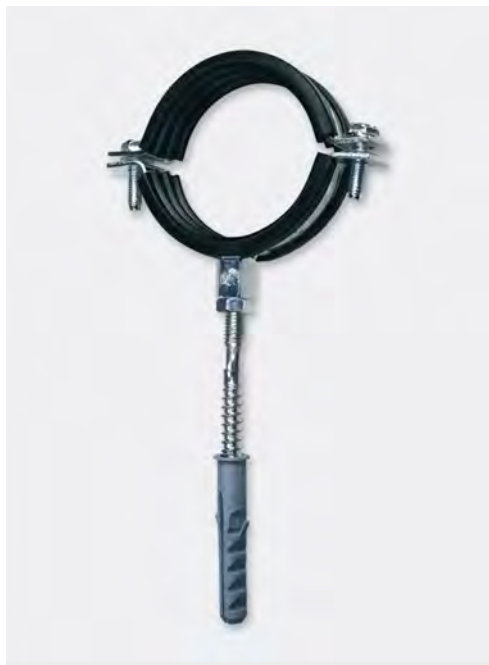

- Collare isofonico in acciaio con gomma premontata.
- Da applicare su: calcestruzzo, pietra naturale, mattone pieno, mattone semipieno, mattone forato.
- Settore di utilizzo: termoidraulica.
- Indicato per il fissaggio di tubature.
- Vantaggi: la gomma intorno al collare, compensa la dilatazione del tubo, e riduce il rumore del liquido in movimento.
- Il collare e' conforme alla normativa DIN 4109 che regola l'isolamento acustico nell'edilizia residenziale.
- Resistente agli agenti atmosferici.
- Fornito con: collare con dado elettrosaldato (filettatura M8+10), gomma profilata, vite di congiunzione con schiacciatura centrale, viti di sicurezza laterali (M6x20), e tassello in nylon.

Code	Desc.	Ø hole mm	For pipes Ø mm	Collar widthxthickness mm	Screw Diam. Ø X length	Tassello Øxlung. mm
1550009900	58-3/8	10	3/8"	20x2	M8x90	10x60
1550009910	58-1/2	10	1/2"	20x2	M8x90	10x60
1550009920	58-3/4	10	3/4"	20x2	M8x90	10x60
1550009930	58-1	10	1"	20x2	M8x90	10x60
1550009940	58-1 1/4	10	1" 1/4	20x2	M8x90	10x60
1550009950	58-1 1/2	10	1" 1/2	20x2	M8x90	10x60
1550009960	58-2	10	2"	20x2	M8x90	10x60
1550009970	58-2 1/2	10	2" 1/2	20x2	M8x90	10x60
1550009980	58-3	10	3"	20x2	M8x90	10x60
1550009990	58-4	10	4"	20x2,5	M8x90	10x60

5

## Fissaggi inox per sanitari

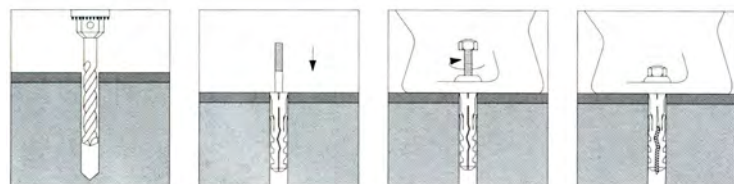

- Fissaggi specifici per l'installazione a pavimento di water e bidet con fori verticali.
- La boccola in nylon permette il centraggio della vite ed impedisce il contatto con il sanitario.
- Tassello in nylon, vite in ottone per una maggiore resistenza alla corrosione, rondella in nylon e dado cieco di serraggio in acciaio inox lucido.

Code	Desc.	Ø hole mm	Hole depth mm
155TA07150	8x45/FS	8	45

## Fissaggio per cassette WC con dado in nylon



- Indicati per il fissaggio di cassette WC a parete.
- Confezione da 2 pezzi.
- Contenuto confezione: 2 tasselli in nylon, 2 viti doppie, 2 dadi nylon.

Code	Desc.	Dimen.	Nut	Conf. pieces	Dimen. dowel
1550009050	53/8x100	M8x100	Nylon	2	10x60

## Tassello a percussione per fascette

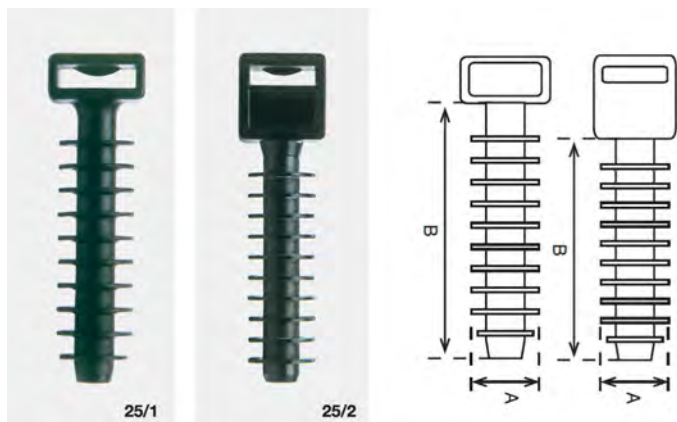

- **Caratteristiche:** tasselli per fissaggio a parete di cavi o tubi.
- Evitano lo sfregamento contro la muratura, potendo scegliere fra due distanze.
- Per fascette di larghezza max 9 mm.

Code	Desc.	A mm	B mm	Foro mm.
155TA06600	25/1	37	6,5	8
155TA06650	25/2	37	13	8

## Guaina spiralata



- In PVC autoestinguente a norma UL 94-VO.
- Colore grigio chiaro RAL 7035.
- Approvazione CE e IMQ.
- Temperatura di esercizio da +5°C a +60°C.
- Resistenza allo schiacciamento > 320N/5cm + 23°C.
- Resistenza all'urto > 2kg h100mm(2J).
- Rigidita' dielettrica: >2000V a 50hz;
- Resistenza all'isolamento:>100mOh.

Code	Desc.	Ø int. mm	Ø Est. mm	Leng. mm
3600002300	52/12	12	16,4	30
3600002320	52/16	16	20,7	30
3600002330	52/20	20	24,7	30
3600002350	52/25	25	30,6	30
3600002370	52/32	32	38	30
3600002380	52/40	40	46,4	30
3600002390	52/50	50	57,2	30

## Modello leggero

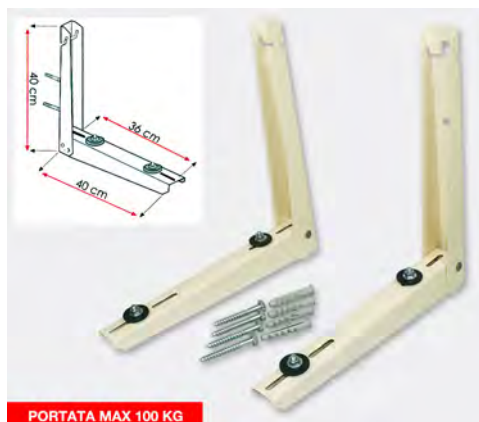
**PORTATA MAX 100 KG**

- Staffe per supporto climatizzatori in acciaio, spessore 1,2mm.
- Verniciate a polvere poliestere per esterni.
- Colore beige RAL 1013.
- Modello con portata massima di 100kg a coppia.
- Ogni staffa è incernierata tramite ribattino in acciaio inox.
- Fornite complete di accessori per il montaggio e piedini antivibranti.
- Dichiarazione di conformità '89/392 a norma CE.

5

Code	Desc.	Model
1550009300	SN 100	Coppia staffe senza traversa portata max 100 Kg

## Mensola doppia con staffa portata massima 110 Kg

**PORTATA MAX 110 KG**

- Omologazioni TUV e GS.

Code	Desc.	Model
1550004615	110KG	MENSOLA DOPPIA CON STAFFA

## Modello medio-pesante

**PORTATA MAX 150 KG**

- Staffe per supporto climatizzatori in acciaio, spessore 1,5mm.
- Verniciate a polvere poliestere per esterni.
- Colore beige RAL 1013.
- Modello con portata massima di 150kg a coppia.
- Ogni staffa è incernierata tramite ribattino in acciaio inox.
- Fornite complete di accessori per il montaggio e piedini antivibranti.
- Dichiarazione di conformità '89/392 a norma CE.

Code	Desc.	Model
1550009350	SN 150	Coppia staffe senza traversa portata max 150 Kg

## Mensola doppia con staffa portata massima 150 Kg



- Omologazioni TUV e GS.

Code	Desc.	Model
1550004620	150 KG	MENSOLA DOPPIA CON STAFFA



## Plumb Plaques

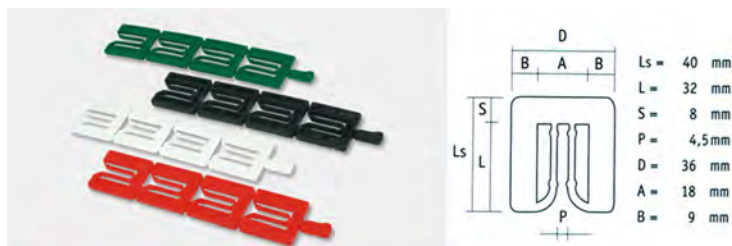

Posizionare il contro telaio. Inserire lo spessore claps nel punto di serramento che può essere una vite o qualsiasi altro sistema. A serraggio avvenuto, distaccare i rimanenti claps.

- For serramentists.
- Plates made of plastic (high density polyethylene).
- For lead-laying, aluminum, wood and PVC doors, windows, doors and windows for the installation.
- Constructed with sealing wings that adapt to the

Code	Desc.	Thickness mm	Color
1550008300	39/2	2	NEUTRO
1550008310	39/3	3	NEUTRO
1550008320	39/4	4	NEUTRO
1550008330	39/5	5	NEUTRO

5

## Placchette per allineamento telai tipo 2 e 3

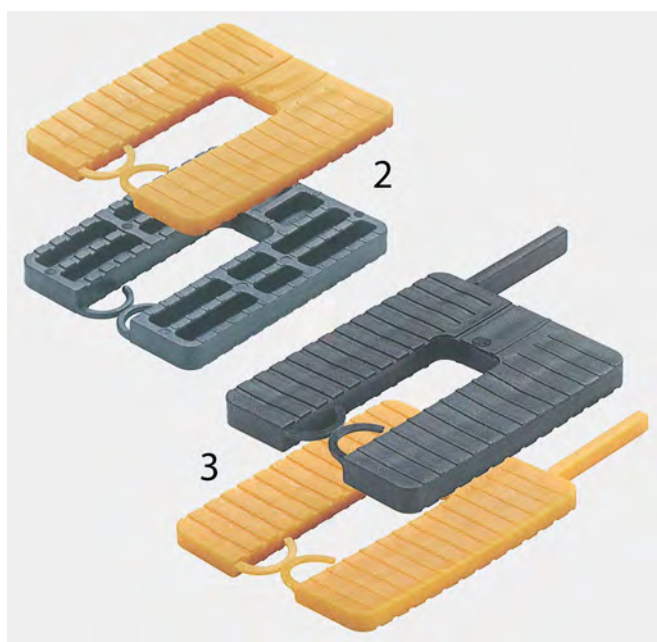

- Placchette in polipropilene per allineamento e messa in piombo di telai di ogni genere: porte, finestre, infissi di ogni tipo, costruzioni in ogni materiale.
- Il materiale con cui sono costruite ne assicura una durata praticamente eterna e una perfetta stabilità dimensionale nel tempo. La forma particolare ne permette l'incastro ed il perfetto posizionamento durante il lavoro. La scalettatura superficiale fa sì che si possano sovrapporre più placchette ed ottenere lo spessore desiderato in modo stabile. Il modello 3 dispone di una linguetta staccabile che facilita moltissimo la posa in opera delle placchette, togliendola dopo l'operazione di fissaggio.
- Disponibili in un'ampia gamma di spessori distinguibili tra di loro facilmente tramite il colore.

Code	Desc.	Dimensions mm	Thickness mm	Color	Type
1550011200	47/1	40x30	1	Bianco	2
1550011210	47/2	40x30	2	Blu	2
1550011220	47/3	40x30	3	Rosso	2
1550011230	47/4	40x30	4	Giallo	2
1550011240	47/5	40x30	5	Verde	2
1550011250	47/6	40x30	6	Nero	2
1550011260	47/8	40x30	8	Grigio	2
1550011270	47/10	40x30	10	Marrone	2
1550011300	47/1	40x30	1	Bianco	3
1550011310	47/2	40x30	2	Blu	3
1550011320	47/3	40x30	3	Rosso	3
1550011330	47/4	40x30	4	Giallo	3
1550011340	47/5	40x30	5	Verde	3
1550011350	47/6	40x30	6	Nero	3
1550011360	47/8	40x30	8	Grigio	3
1550011370	47/10	40x30	10	Marrone	3
1550011400	48/1	65x52,5	1	Bianco	3
1550011410	48/2	65x52,5	2	Blu	3
1550011420	48/3	65x52,5	3	Rosso	3
1550011430	48/4	65x52,5	4	Giallo	3
1550011440	48/5	65x52,5	5	Verde	3
1550011450	48/6	65x52,5	6	Nero	3
1550011460	48/8	65x52,5	8	Grigio	3
1550011470	48/10	65x52,5	10	Marrone	3

## Tappini copriforo per serramenti



- Tappi copriforo per serramenti in alluminio.
- Costruiti in pvc morbido.
- Diametro e colori diversi per adattarsi ad ogni tipo di serramento.

Code	Desc.	Color	Ø testa mm	Ø foro int. mm
2930004140	4132/NE	NERO	16	12
2930004150	4132/GR	GRIGIO	16	12
2930004160	4132/BR	BRONZO	16	12
2930004170	4132/BI	BIANCO	16	12
2930004180	4132/VE	VERDE	16	12
2930004190	4132/MA	MARRONE	16	12
2930004200	4133/NE	NERO	16	14
2930004210	4133/GR	GRIGIO	16	14
2930004220	4133/BR	BRONZO	16	14
2930004230	4133/BI	BIANCO	16	14
2930004240	4133/VE	VERDE	16	14
2930004250	4133/MA	MARRONE	16	14

## Tamponi distanziatori



- Tamponi distanziatori in materiale espanso a cellule chiuse.
- Proteggono manufatti con superfici delicate durante il trasporto o lo stoccaggio, come per es. porte, serramenti, pannellature, lastre di vetro, specchi, lastre di pietra e metallo, ecc.
- Fissaggio sicuro su tutti i tipi di superfici. Non alterano il colore della superficie.
- Al fine del mantenimento delle caratteristiche del prodotto si consiglia la sua conservazione in un ambiente fresco e asciutto e al riparo dai raggi solari.
- Si consiglia inoltre l'applicazione dei tamponi solo dopo aver eliminato

Code	Desc.	Dimens. (mm)	Consistency	Color
4840001300	10 M	40x40x10h	morbido	Bianco
4840001310	25 M	40x40x25h	morbido	Bianco
4840001320	10 R	40x40x10h	rigido	Grigio
4840001330	25 R	40x40x25h	rigido	Grigio
4840001530	10 MR	40x40x10h	molto rigido	Nero
4840001540	20 MR	40x40x20h	molto rigido	Nero

## Spessori per vetrocamera



- Spessori in polipropilene per costruzione vetrocamera.
- Per serramentisti.
- Misure 20 e 10 per adattarsi meglio agli spazi.
- Di colori diversi per un'immediata individuazione della misura occorrente.

Code	Desc.	Dimensions	Color
155TA08300	34/20X2	20x2x28	Giallo
155TA08310	34/20X3	20x3x28	Rosso
155TA08320	34/20X4	20x4x28	Bianco
155TA08330	34/20X5	20x5x28	Nero
155TA08340	34/20X7	20x7x28	Grigio
155TA08350	34/10X2	10x2x30	Giallo
155TA08360	34/10X3	10x3x30	Rosso
155TA08370	34/10X4	10x4x30	Bianco
155TA08380	34/10X5	10x5x30	Nero
155TA08390	34/10X7	10x7x30	Grigio

## Spessori per vetrocamera standard



- Spessori in polipropilene per vetrocamera standard, per lo spessoramento dei cristalli, la giusta distribuzione del peso e degli sforzi, ed una durata illimitata di ogni tipo di serramento: alluminio, legno o PVC.
- Realizzati in polipropilene, compatibili con ogni tipo di sigillante per bordo composito e pellicole secondo la normativa TR3, estrema resistenza all'invecchiamento, termostabile e dalla enorme portata, da 336 Kg a +80°C fino a 2039 Kg a -20°C.

Code	Desc.	Measure mm	Thickness mm	Color
155TA10610	41/1	100x20	1	Bianco
155TA10620	41/2	100x20	2	Blu
155TA10630	41/3	100x20	3	Rosso
155TA10640	41/4	100x20	4	Giallo
155TA10650	41/5	100x20	5	Verde
155TA10660	41/6	100x20	6	Nero
155TA10710	42/1	100x24	1	Bianco
155TA10720	42/2	100x24	2	Blu
155TA10730	42/3	100x24	3	Rosso
155TA10740	42/4	100x24	4	Giallo
155TA10750	42/5	100x24	5	Verde
155TA10760	42/6	100x24	6	Nero
155TA10810	43/1	100x26	1	Bianco
155TA10820	43/2	100x26	2	Blu
155TA10830	43/3	100x26	3	Rosso
155TA10840	43/4	100x26	4	Giallo
155TA10850	43/5	100x26	5	Verde
155TA10860	43/6	100x26	6	Nero
155TA10910	44/1	100x28	1	Bianco
155TA10920	44/2	100x28	2	Blu
155TA10930	44/3	100x28	3	Rosso
155TA10940	44/4	100x28	4	Giallo
155TA10950	44/5	100x28	5	Verde
155TA10960	44/6	100x28	6	Nero

## Spessori per vetrocamera angolari



- Spessori in polipropilene per vetrocamera standard, per lo spessoramento dei cristalli, la giusta distribuzione del peso e degli sforzi, ed una durata illimitata di ogni tipo di serramento: alluminio, legno o PVC.
- Realizzati in polipropilene con la speciale forma con intaglio a V per il posizionamento specifico negli angoli. La particolare forma permette di spezzarli e sagomarli senza che le due sezioni si separino tra di loro.
- Realizzati con traversine che sostengono i cristalli permettendo allo stesso tempo il passaggio dell'aria intorno al vetro. Lo spessore si distingue facilmente grazie alla diversa colorazione.

Code	Desc.	Measure mm	Thickness mm	Color
155TA11020	45/2	80x20	2	Rosso
155TA11030	45/3	80x20	3	Verde
155TA11040	45/4	80x20	4	Giallo
155TA11050	45/5	80x20	5	Blu
155TA11060	45/6	80x20	6	Nero

5

## Spessori per vetri float singoli



- Spessori in polipropilene in barrette di lunghezza 210 mm, studiati appositamente per la posa in opera di vetri singoli, chiamati comunemente Float, di qualsiasi tipo: normali, extrachiari, temprati, stratificati, ecc.
- Utilizzabili su qualsiasi supporto in legno, PVC, alluminio, ecc. Permettono il giusto spessoramento e la durata praticamente eterna del manufatto. Utilizzabili per la costruzione di infissi o di mobilio, contenitori, armadi, ecc.
- Durata eterna, altissime portate, disponibili in vari spessori distinguibili tramite la colorazione.

Code	Desc.	Measure mm	Thickness mm	Color
155TA11130	46/3	210x10	3	Giallo
155TA11140	46/4	210x10	4	Rosso
155TA11150	46/5	210x10	5	Nero
155TA11180	46/8	210x10	8	Bianco



## Squadrette per controtelai

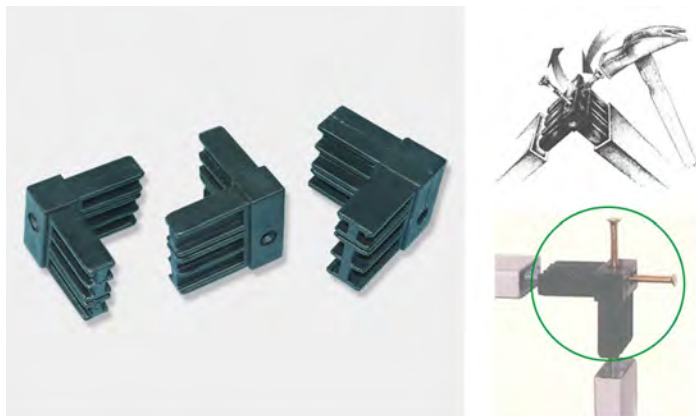

- Squadrette in materiale plastico comprese di viti.
- Semplice e veloce per l'assemblaggio di controtelai senza ricorrere a saldature.
- Trattamento anticorrosivo.
- Da utilizzare con tubi zincati spessore 1,5.
- Squadratare automatica.

Code	Desc.	Dimensions mm	For pipes mm
1550008610	41/40X15	45x45x40	40x15x1,5
1550008620	41/40X20	50x50x40	40x20x1,5

5

## Zanche per controtelai

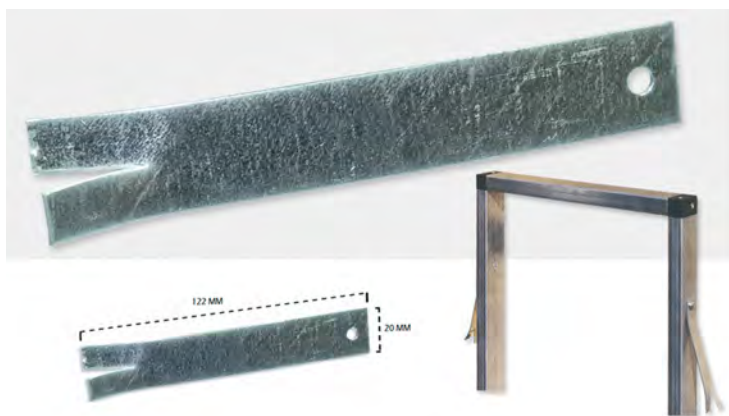

- Zanca in acciaio zincato.
- Da fissare su controtelaio tramite viti autoforanti.
- La zanca aumenta l'aderenza e la tenuta sul muro del controtelaio.

Code	Desc.	Ø hole mm
1550008630	42	5



## Cardine a saldare

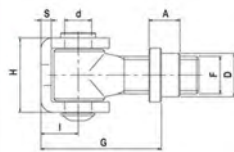

- Cardine a saldare interamente in acciaio zincato, perno sfilabile per la regolazione e per la lubrificazione.

Code	Desc.	D mm	d mm	F	G min/max mm	I mm.	H mm	S mm	A mm
2970013250	83/18	21	14	M18	47-70	18	36	5	15
2970013260	83/20	25	14	M20	51-70	21	39	6	20,5

## Cardine a saldare regolabile

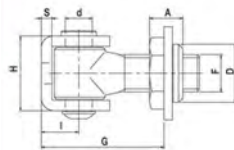

- Cardine a saldare interamente in acciaio zincato, perno sfilabile per la regolazione e per la lubrificazione. Dado mobile per la regolazione fine del cancello dopo il montaggio.

Code	Desc.	D mm	d mm	F	G min/max mm	I mm.	H mm	S mm	A mm
2970013270	84/18	28	14	M18	50-70	18	36	5	15
2970013280	84/20	28	14	M20	57/80	21	39	6	16
2970013285	84/24	34	17	M24	65-90	26	47	6	17

## Cardine a saldare regolabile con piastra di fissaggio

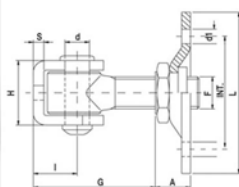

- Cardine a saldare interamente in acciaio zincato, montato su piastra forata per il fissaggio, perno sfilabile per la regolazione e la lubrificazione. Dado mobile per la regolazione fine del cancello dopo il montaggio.

Code	Desc.	d mm	F	G min/max mm	I mm.	H mm	S mm	A mm	L mm	d1 mm	INT. mm
2970014840	151/18	14	M18	40-60	18	36	5	14	60x90	9	40x70
2970014850	151/20	14	M20	46-74	21	39	6	20	100	11	70
2970014860	151/24	17	M24	52-76	26	47	6	20	120	11	90

5

## Cardine regolabile a saldare con supporto per muratura

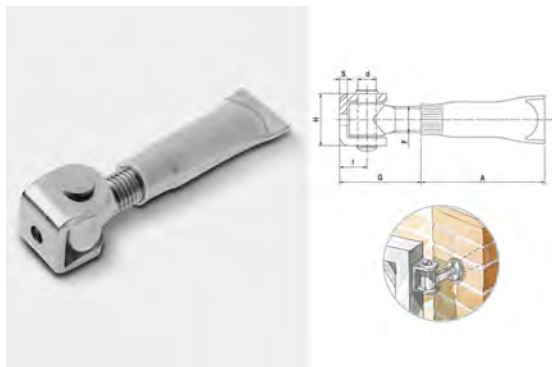

- Cardine a saldare interamente in acciaio zincato, montato su supporto filettato a murare, perno sfilabile per la regolazione e la lubrificazione.

Code	Desc.	D mm	F mm	G min/max mm	I mm.	H mm	S mm	A mm
2970014930	154/18	14	M18	40-60	18	36	5	66
2970014940	154/20	14	M20	46-70	21	39	6	95
2970014950	154/24	17	M24	52-76	26	47	6	100

5

## Cardine a saldare regolabile con ali

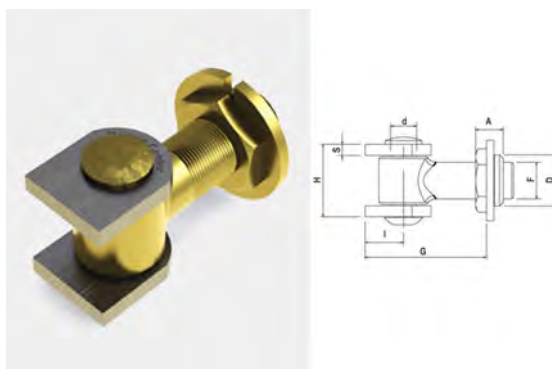

Code	Desc.	D mm	d mm	F	G min/max mm	I mm.	H mm	S mm	A mm
2970013290	85/18	28	14	M18	50-70	18	36	5	15
2970013300	85/20	28	14	M20	57-80	21	39	6	16
2970013305	85/24	34	17	M24	65-90	26	47	6	17

## Cardine a saldare regolabile con ali con piastra di fissaggio

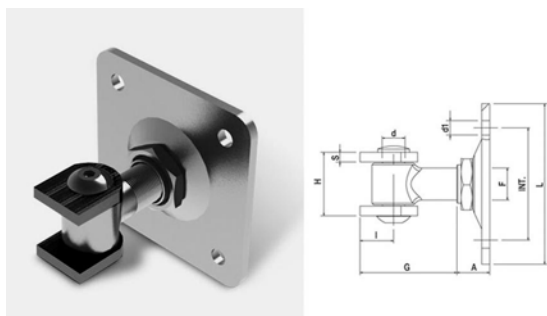

- Cardine a saldare interamente in acciaio zincato, montato su piastra forata per il fissaggio, perno sfilabile per la regolazione e la lubrificazione. Dado mobile per la regolazione fine del cancello dopo il montaggio.
- Fissaggio tramite saldatura delle due ali in acciaio grezzo.

Code	Desc.	d mm	F	G min/max mm	I mm.	H mm	S mm	A mm	L mm	d1 mm	INT. mm
2970014870	152/18	14	M18	40-60	18	36	5	14	60x90	9	40x70
2970014880	152/20	14	M20	46-74	21	39	6	20	100	11	70
2970014890	152/24	17	M24	52-76	26	47	6	20	120	11	90

## Cardine a cavallotto regolabile

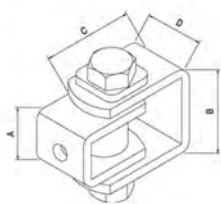

Code	Desc.	A mm	B mm	C mm	D mm
2970013310	86/P	30	45	64-70	30
2970013320	86/G	45	60	64-73	35

## Cardine a saldare regolabile con fascia

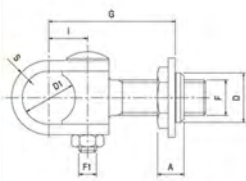

- Cardine a saldare interamente in acciaio zincato, perno sfilabile per la regolazione e per la lubrificazione. Dado mobile per la regolazione fine del cancello dopo il montaggio.
- Fissaggio tramite fascia in acciaio zincato smontabile.

Code	Desc.	D mm	D1 mm.	F	F1	G min/max mm	I mm.	S mm	A mm
2970013330	87/30	28	30	M20	M10	50-78	22	6	15
2970013340	87/35	34	35	M24	M10	57-88	26	6	17
2970013350	87/40	36	40	M30	M12	70-110	34	6	24

## Cardine regolabile con fascia con piastra di fissaggio

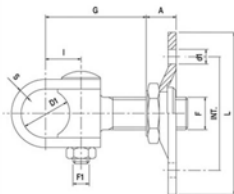

- Cardine a saldare interamente in acciaio zincato, montato su piastra forata per il fissaggio, perno sfilabile per la regolazione e la lubrificazione. Dado mobile per la regolazione fine del cancello dopo il montaggio.
- Fissaggio tramite fascia in acciaio zincato smontabile.

Code	Desc.	L mm	D1 mm.	F mm	F1 mm	G min/max mm	I mm.	S mm	A mm	d1 mm	INT. mm
2970014900	153/30	100	30	M20	M10	39-63	22	6	20	11	70
2970014910	153/35	120	35	M24	M10	45-74	26	6	20	11	90
2970014920	153/40	120	40	M30	M12	70-110	34	6	25	11	90

## Tronchetto di giunzione con foro

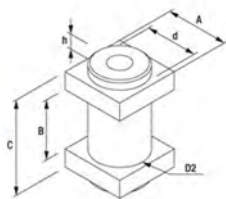

- Tronchetto di giunzione per montaggio ed utilizzo con cardini a fascia. Foro passante centrale, realizzazione in acciaio zincato.

Code	Desc.	d mm	D2 mm	A mm	B mm	C mm	h mm
2970013360	88/30	29	28,5	35	33	53	5
2970013370	88/35	34	33,5	40	38	58	5

5

## Tronchetto di giunzione per montanti

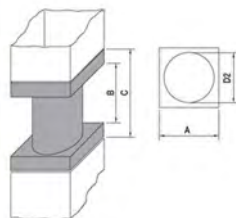

Code	Desc.	D2 mm	A mm	B mm	C mm
2970013380	87/40	38,5	50	45	65

## Cardine regolabile a saldare "Pascal" con piastra di fissaggio

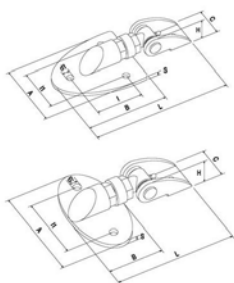

- Cardine innovativo e brevettato per l'utilizzo su cancelli a singola o doppia anta, ma anche su portoni industriali anche di grandi dimensioni.
- Vantaggi: montaggio velocissimo, Nessun foro di grande diametro sulle colonne, regolazioni velocissime e semplici, spazi ridotti fra colonne e manufatto, nessun gioco nei movimenti, presenza di ingrassatore per la lubrificazione periodica.
- Disponibile in versione con piastra di fissaggio zincata o verniciata nera a polvere epossidica.

Code	Desc.	A mm	B mm	C mm	d1 mm	I mm.	I1 mm	M mm	H mm	L mm	S mm	Versione
2970014960	155Z	120	140	46,5	12	80	80	20	40	235/247	5	Zincato
2970014965	155ZC	150	80	46,5	12	-	100	20	40	178/190	5	Zincato
2970014970	155V	120	140	46,5	12	80	80	20	40	235/247	5	Verniciato
2970014975	155VC	150	80	46,5	12	-	100	20	40	178/190	5	Verniciato

## Piastra e perno per cancelli ad ante

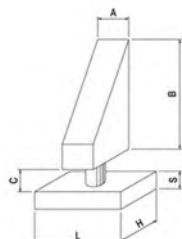

Code	Desc.	L x H x S mm	A mm	B mm	C mm
2970013430	91/20	70x60x15	30	80	12

## Piastra e perno inferiore leggeri

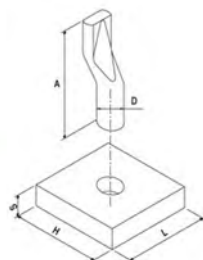

- Perno inferiore completo di piastra per movimento ad ante di cancelli leggeri. Realizzato interamente in acciaio zincato, applicabile tramite saldatura.

Code	Desc.	A mm	H mm	L mm	S mm	D mm
2970013450	92/P	89	70	60	15	20
2970013460	92/G	96	70	60	20	24

## Piastra girevole superiore a saldare

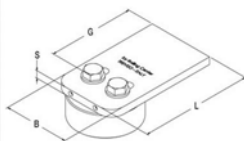

Code	Desc.	D mm	d mm	A mm	H mm	B mm	L mm	S mm	G min/max mm	Payload kg
2970013465	93/50	50	23	25	43	50	80	8	48-60	450
2970013470	93/70	70	32	25	43	70	120	8	80/95	1000

## Piastra girevole inferiore a pavimento

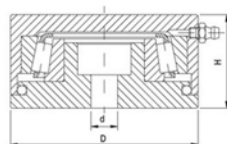

Code	Desc.	D mm	d mm	H mm	Payload kg
2970013475	94/50	50	8	31	1000
2970013480	94/70	70	10	35	2500



## Piastra girevole superiore con fori per colonna

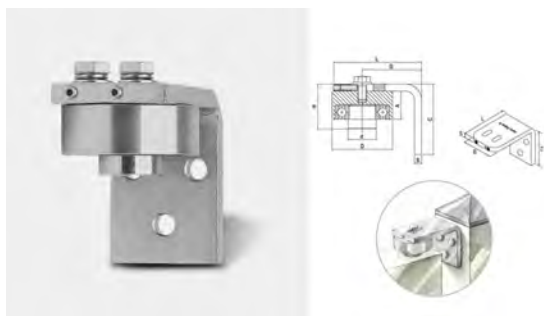

- Piastra superiore girevole con movimento su cuscinetto a sfere, fissaggio tramite fori su qualsiasi tipo di colonna, realizzata interamente in acciaio zincato.
- Applicazioni su cancelli leggeri e pesanti, completamente regolabile dopo l'installazione.
- Possibilità di utilizzo con la piastra girevole inferiore con fori per colonna.

Code	Desc.	D mm	d mm	A mm	H mm	B mm	L mm	C mm	S mm	G min/max mm	Payload kg
2970015140	163/50	50	23	25	43	50	80	70	8	56-64	400
2970015150	163/70	70	32	32	51	70	100	80	8	65-80	800

5

## Piastra girevole inferiore con fori per colonna

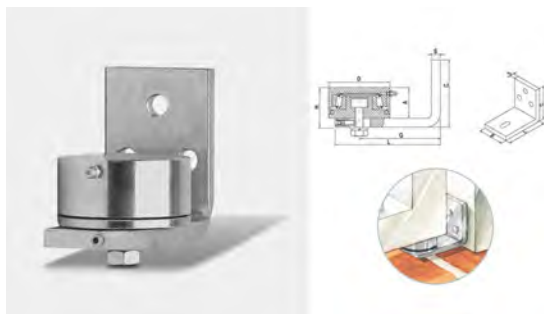

- Piastra inferiore girevole con movimento su cuscinetto a rulli, fissaggio tramite fori su qualsiasi tipo di colonna, realizzata interamente in acciaio zincato.
- Applicazioni su cancelli leggeri e pesanti, completamente regolabile dopo l'installazione.
- Possibilità di utilizzo con la piastra girevole superiore con fori per colonna.

Code	Desc.	D mm	A mm	H mm	B mm	L mm	C mm	S mm	G min/max mm	Payload kg
2970015160	164/50	50	31	39	40	80	70	8	52-64	200
2970015170	164/70	70	35	45	60	100	80	10	65-80	300

## Battente d'arresto per cancelli a due ante

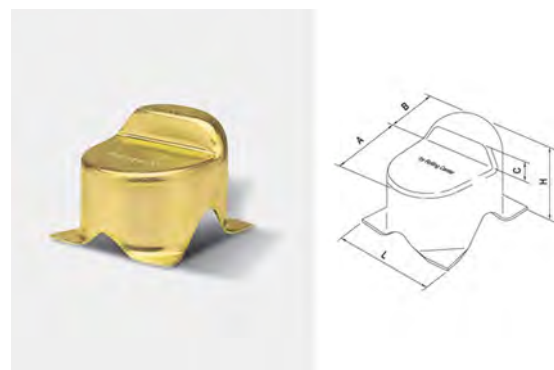

Code	Desc.	L mm	H mm	A mm	B mm	C mm
2970013490	95	92	77	63	35	20

## Battente d'arresto con fori per cancelli a due ante

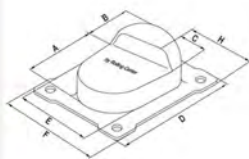
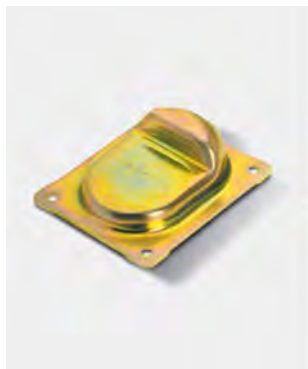

Code	Desc.	A mm	B mm	C mm	D mm	E mm	F mm	H mm
2970013500	96	88	42	20	157	90	130	40

## Cavi di sicurezza flessibili in acciaio

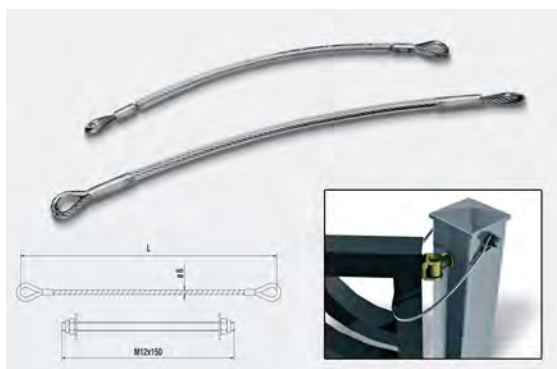

- Cavi anticaduta in acciaio zincato Ø 6x133 fili con guaina in pvc di protezione. Indispensabili per la messa in sicurezza e la marcatura CE dei cancelli a battente (UNI EN 12604:2002).
- Peso massimo sopportabile di 1800 Kg.

Code	Desc.	Leng. mm
2970014980	156/30	300
2970014990	156/50	500

## Tappi copri pilastro in acciaio zincato

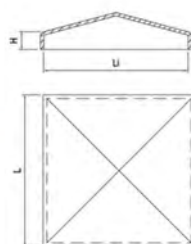

Code	Desc.	L mm	Li mm	H mm
2970013510	97/4	45x45	41x41	7
2970013520	97/5	55x55	51x51	7
2970013540	97/8	85x85	81x81	7
2970013550	97/10	105x105	101x101	7

## Tappi copri pilastro rettangolari in nylon

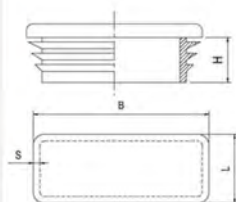

- Tappi copricolonna in nylon, fissaggio ad incastro, ottima tenuta all'acqua e finitura estetica per ogni colonna di sezione rettangolare.
- Fissaggio a pressione mediante alette laterali sottotesta.

Code	Desc.	H mm	B mm	L mm	S mm
2970013560	98/40x20	14	40	20	1-1,5
2970014830	98/60x30	14,2	60	30	1-2,5
2970013570	98/80x40	15	80	40	1-3

5

## Tappi copri pilastro quadrati in nylon

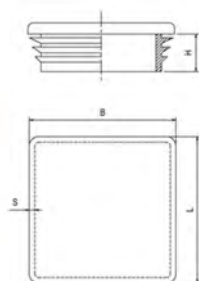

Code	Desc.	H mm	B mm	L mm	s mm
2970013580	99/15	11	15	15	1-2
2970013590	99/20	12	20	20	1-3
2970013600	99/25	12	25	25	1-3
2970013610	99/30	12	30	30	2,4-4,5
2970013620	99/31	11	30	30	1-2,5
2970013630	99/40	14	40	40	1-3
2970013640	99/40	14	45	45	1-3
2970013650	99/50	15	50	50	2,6-4
2970013660	99/60	15	60	60	1,5-3,5
2970013670	99/70	18	70	70	2-5
2970013680	99/80	16	80	80	2-4
2970013690	99/90	25	90	90	3-5
2970013700	99/100	28	100	100	1-4
2970013710	99/120	26	120	120	2,5-5

- Tappi copricolonna in nylon, fissaggio ad incastro, ottima tenuta all'acqua e finitura estetica per ogni colonna di sezione quadrata.
- Fissaggio a pressione mediante alette laterali sottotesta.

5

## Tappi copri pilastro rotondi in nylon

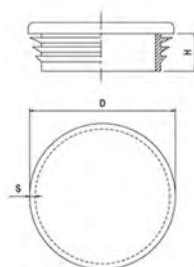

- Tappi copricolonna in nylon, fissaggio ad incastro, ottima tenuta all'acqua e finitura estetica per ogni colonna di sezione rotonda.
- Fissaggio a pressione mediante alette laterali sottotesta.

Code	Desc.	H mm	D mm	S mm	For pipe
2970013720	100/32	12	32	1-2,5	1"
2970013730	100/42	11,5	42	1-2,5	1-1/4"
2970013740	100/48	11,5	48	1-2	1-1/2"
2970013750	100/60	17/8	60	1,5-3	2"

## Cerniera in ferro a saldare a 2 ali

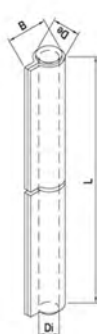

- Cerniera in ferro a due ali chiuse, montaggio a saldare, realizzata in acciaio grezzo. Perno sfilabile e rondella in acciaio.

Code	Desc.	L mm	B mm	DE mm	Di mm
2970013760	101/60	60	13	9,5	6
2970013770	101/80	80	16,5	12	8
2970013780	101/100	100	18	13,5	8,5
2970013790	101/120	120	19,5	15	10
2970013800	101/140	140	22	16,5	10,5
2970013810	101/170	170	23,5	17,5	12
2970013820	101/200	200	25	22	14

## Cerniera in ferro a saldare a 3 ali

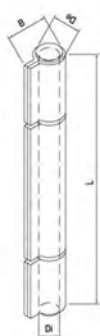

- Cerniera in ferro a tre ali chiuse, montaggio a saldare, realizzata in acciaio grezzo. Perno sfilabile e rondella in acciaio.

Code	Desc.	L mm	B mm	DE mm	Di mm
2970013827	102/100	100	18	13,5	8,5
2970013828	102/120	120	19,5	15	10
2970013829	102/140	140	22	16,5	10,5
2970013830	102/170	170	23,5	17,5	12
2970013840	102/200	200	27	20	14

## Cerniera in ferro a saldare a 2 ali con tappo, perno fisso

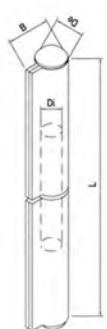

- Cerniera in ferro a due ali chiuse, montaggio a saldare, realizzata in acciaio grezzo. Perno fisso in acciaio, chiusa con tappo alle estremità.

Code	Desc.	L mm	B mm	DE mm	Di mm
2970013845	103/60	60	17	10	6
2970013850	103/80	80	17	12	8
2970013860	103/100	100	19	13,5	9
2970013861	103/120	120	20	14,5	10
2970013862	103/140	140	21	16	11
2970013863	103/170	170	23,5	17	12
2970013864	103/200	200	26,5	20	14

## Cerniera a tappo con ali lunghe

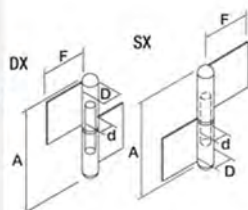

- Cerniere in acciaio grezzo con ali lunghe, versioni a tappo destra e sinistra. Dotate di perno fisso in acciaio.

Code	Desc.	A mm	F mm	D mm	d mm
2970013870	104/60DX	60	18	14	8,2
2970013880	104/60SX	60	18	14	8,2
2970013890	104/80DX	80	18	14	8,2
2970013900	104/80SX	80	18	14	8,2
2970013910	104/100DX	100	33	17	10,2
2970013920	104/100SX	100	33	17	10,2

## Cerniera pesante a due ali aperte

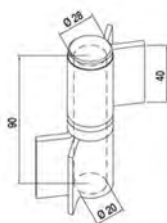

- Cerniera pesante in acciaio grezzo a due ali aperte, fissaggio tramite saldatura. Dotata di perno sfilabile e rondella in acciaio.

Code	Desc.
2970013930	105

## Cerniera pesante a tre ali aperte

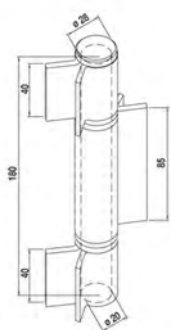

- Cerniera pesante in acciaio grezzo a tre ali aperte, fissaggio tramite saldatura. Dotata di perno sfilabile e rondella in acciaio.

Code	Desc.
2970013940	106

5

## Cerniera a goccia con perno zincato



- Cerniera a goccia in acciaio grezzo, perno fisso in acciaio zincato, rondella in acciaio.

Code	Desc.	A mm	D mm	B mm	Di mm
2970013950	107/40	40	10	12	6
2970013960	107/60	60	10	12	6
2970013970	107/80	80	12	14	7
2970013980	107/100	100	14	16	8
2970013990	107/120	120	16	18	9
2970014000	107/140	140	16	18	9

## Cerniera a goccia Ø 22x25 con cuscinetto reggispira

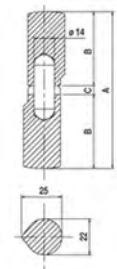

- Cerniera a goccia in acciaio grezzo, perno sfilabile in acciaio zincato o ottone, cuscinetto reggispira a sfere in acciaio cementato.

Code	Desc.	Linchpin	A mm	B mm	C mm
2970015000	157/64	Acciaio	135	64	7
2970015010	157/75	Acciaio	157	75	7
2970015020	157/100	Acciaio	207	100	7
2970015030	158/64	Ottone	135	64	7
2970015040	158/75	Ottone	157	75	7
2970015050	158/100	Ottone	207	100	7

## Cerniera a goccia regolabile

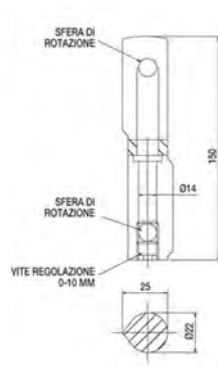

- Cerniera a goccia in acciaio grezzo, perno fisso in acciaio, movimento su doppia sfera interna.
- Dotata di vite di regolazione interna, range di regolazione 0 – 10 mm.

Code	Desc.
2970014010	108



## Catenaccio ad avvitare, asta piatta e portalucchetto

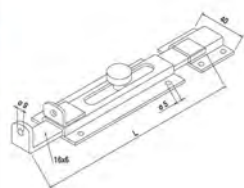

- Catenaccio leggero in acciaio zincato con fori per il fissaggio, completo di incontro.
- Asta di chiusura piatta 16 X 6 mm, foro per chiusura tramite lucchetto.

Code	Desc.	L mm
2970014050	110/100	100
2970014060	110/150	150
2970014070	110/180	180
2970014080	110/230	230

## Catenaccio ad avvitare, asta tonda e portalucchetto

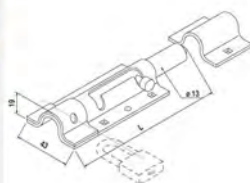

- Catenaccio pesante in acciaio zincato con fori per il fissaggio, completo di incontro.
- Asta di chiusura rotonda diametro 13 mm, foro per chiusura tramite lucchetto.

Code	Desc.	L mm
2970014020	109/150	150
2970014030	109/200	200
2970014040	109/250	250

## Catenaccio leggero verticale ad avvitare

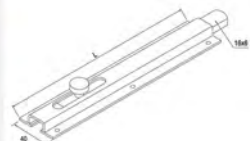

- Catenaccio leggero in acciaio zincato con fori per il fissaggio. Fornito senza incontro, asta di chiusura piatta 16 X 6 mm.

Code	Desc.	L mm
2970014090	111/150	150
2970014100	111/200	200
2970014110	111/250	250
2970014120	111/300	300
2970014130	111/400	400
2970014140	111/500	500

## Catenaccio pesante a saldare



- Catenaccio pesante in acciaio tropicalizzato, applicazione a saldare, fornito senza incontro. Asta di chiusura piatta 25 X 10 mm.

Code	Desc.	L mm
2970014150	112/300	300
2970014160	112/400	400
2970014170	112/500	500

## Paletto leggero quadrato a saldare

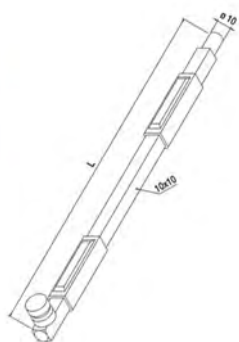

- Paletto leggero in acciaio tropicalizzato, fissaggio a saldare, fornito senza incontro.
- Asta di chiusura sezione 14 X 14 mm, punta arrotondata, doppia guida.

Code	Desc.	L mm
2970014180	113/130	130
2970014190	113/300	300
2970014195	113/500	500

5

## Paletto pesante quadrato a saldare

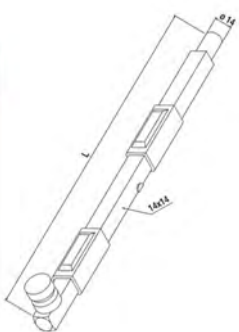

- Paletto leggero in acciaio tropicalizzato, fissaggio a saldare, fornito senza incontro.
- Asta di chiusura sezione 14 X 14 mm, punta arrotondata, doppia guida.

Code	Desc.	L mm
2970014200	114/330	330
2970014210	114/600	600

## Catenaccio a leva movimento singolo

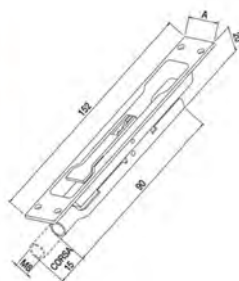

- Catenaccio a leva ad incasso completamente in acciaio zincato, movimento per singola asta
- Fissaggio tramite viti, predisposizione dei fori sul corpo. Corsa utile 15 mm. Attacco filettato femmina per barre M8.

Code	Desc.	A mm
2970014230	116/16	16
2970014240	116/20	20

## Maniglia di blocco in acciaio

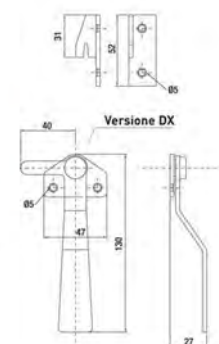

- Maniglia di blocco per serramenti in ferro. Costruita in acciaio zincato, fissaggio a vite tramite fori predisposti. Completa di incontro, nelle versioni DX ed SX.

Code	Desc.	Versione
2970014250	114/DX	Destra
2970014260	117/SX	Sinistra

## Chiavistello per sportelli

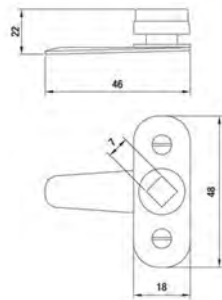

- Chiavistello per sportelli in acciaio zincato con quadro di azionamento lato 7 mm.

Code	Desc.
2970014270	118

## Chiavetta quadrata da 7 mm per chiavistelli



- Chiavetta in zama con foro quadrato per azionamento chiavistelli per sportelli con quadro da 7 mm.

Code	Desc.
2970014280	119

## Chiavistello a leva per sportelli

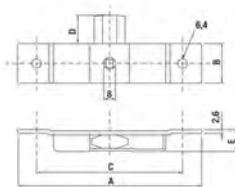

- Chiavistello per sportelli in acciaio zincato con foro quadro di azionamento lato 8 mm.

Code	Desc.	A mm	B mm	C mm	D mm	E mm
2970014290	120/18	101	18	82	15	12
2970014300	120/27	126	27	101	20	15

## Chiavetta quadrata da 8 mm per chiavistelli

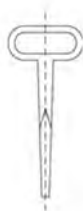

- Chiavetta in zama lunga a sezione quadrata per azionamento chiavistelli per sportelli con quadro da 8 mm.

Code	Desc.
2970014310	121

5

## Serratura a gancio con cilindro

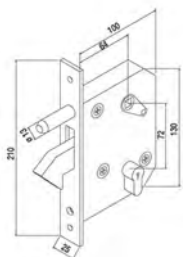

- Serratura a gancio in acciaio interamente zincata, montaggio ad incasso, con quadro maniglia di 8 mm.
- Scatola della serratura in acciaio stampato, gancio di chiusura in acciaio forgiato.
- Completa di cilindro europeo e tripla chiave.

Code	Desc.
2970014320	122

5

## Serratura piccola a gancio con cilindro

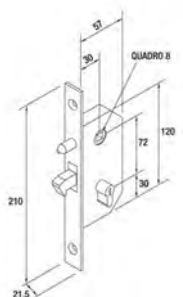

- Serratura a gancio in acciaio interamente zincata, montaggio ad incasso, con quadro maniglia di 8 mm.
- Scatola della serratura in acciaio stampato, gancio di chiusura in acciaio forgiato.
- Completa di cilindro europeo e tripla chiave, incontro in acciaio per chiusura.

Code	Desc.
2970014330	123

## Maniglia a leva regolabile con vite

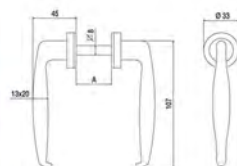

- Maniglia in lega verniciata adatta anche per esterni, quadro di azionamento di 8 mm, universale.
- Larghezza di montaggio regolabile da 25 a 38 mm. Fissaggio tramite vite.

Code	Desc.	A mm
2970015060	159	25-38

## Maniglia a leva regolabile con grano

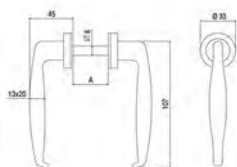

- Maniglia in lega verniciata adatta anche per esterni, quadro di azionamento di 8 mm, universale.
- Larghezza di montaggio regolabile da 36 a 65 mm. Fissaggio tramite grano a cava esagonale incassato.

Code	Desc.	A mm
2970014340	124	35-65

## Ruote semplici per cancelli gola a "V"

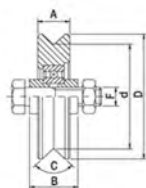

- Ruote in acciaio C45 tropicalizzato, fissaggio tramite asse filettato, cuscinetto singolo, gola per guide a V.

Code	Desc.	D mm	d mm	A mm	B mm	C	F	L x H x S mm	Payload kg
2970014350	125/80	80	65	20	34	96°	M12x50	80x30x3	190
2970014360	125/100	100	85	20	34	96°	M14x60	100x40x3	240
2970014370	125/120	120	105	20	34	96°	M14x60	120x40x3	270
2970014375	125/140	140	125	20	34	96°	M14x60	120x40x3	310

## Ruote semplici per cancelli gola tonda

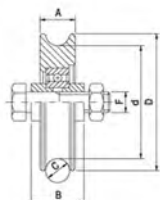

- Ruote in acciaio C45 tropicalizzato, fissaggio tramite asse filettato, cuscinetto singolo, gola per guide rotonde.

Code	Desc.	D mm	d mm	A mm	B mm	C (O)	F	L x H x S mm	Payload kg
2970014380	126/80	80	61	26	34	21	M14x60	80x40x30	190
2970014390	126/100	100	81	26	34	21	M14x60	100x40x3	240
2970014400	126/120	120	101	26	34	21	M14x60	120x40x3	270

## Ruote semplici per cancelli gola a "V" doppio cuscinetto

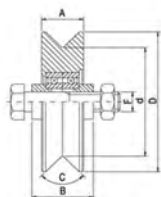

- Ruote in acciaio C45 tropicalizzato, fissaggio tramite asse filettato, cuscinetto doppio, gola per guide a V.

Code	Desc.	D mm	d mm	A mm	B mm	C	F	L x H x S mm	Payload kg
2970014410	127/100	100	80	30	44	96°	M14x70	100x50x3	450
2970014420	127/120	120	100	30	44	96°	M14x70	120x50x3	480
2970014430	127/140	140	119	30	44	96°	M14x70	140x50x3	510
2970014435	127/160	160	140	30	44	96°	M17x70	160x50x3	560

## Ruote semplici per cancelli gola tonda doppio cuscinetto

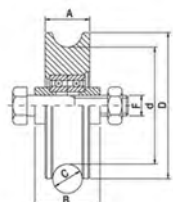

- Ruote in acciaio C45 tropicalizzato, fissaggio tramite asse filettato, cuscinetto doppio, gola per guide rotonde.

Code	Desc.	D mm	d mm	A mm	B mm	C (O)	F	L x H x S mm	Payload kg
2970014440	128/100	100	80	30	44	21	M14x70	100x50x3	450
2970014450	128/120	120	100	30	44	21	M14x70	120x50x3	480
2970014460	128/140	140	120	30	44	21	M14x70	140x50x3	510
2970014465	128/160	160	140	30	44	21	M14x70	160x50x3	560



## Ruote semplici per cancelli gola a "V" doppio cuscinetto-Predisposte per perno ingrassatore

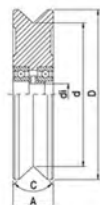

- Ruote in acciaio C45 tropicalizzato, fissaggio tramite asse filettato, cuscinetto doppio, gola per guide a V.
- Perno con ingrassatore fornito a parte.

Code	Desc.	D mm	d mm	Di mm	A mm	C	Payload kg
2970014470	129/100	100	80	20	30	96°	450
2970014480	129/140	140	120	20	30	96°	530
2970014485	129/160	160	133	20	38	96°	640

5

## Ruote semplici per cancelli gola tonda doppio cuscinetto-Predisposte per perno ingrassatore

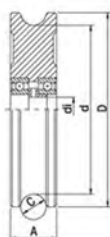

- Ruote in acciaio C45 tropicalizzato, fissaggio tramite asse filettato, cuscinetto doppio, gola per guide rotonde.
- Perno con ingrassatore fornito a parte.

Code	Desc.	D mm	d mm	Di mm	A mm	C (O)	Payload kg
2970014490	130/100	100	81	20	30	21	450
2970014500	130/120	120	101	20	30	21	490

## Perni con ingrassatore per ruote

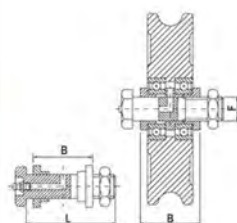

- Perni filettati dotati di ingrassatore per il montaggio delle ruote predisposte a doppio cuscinetto.
- Da scegliere in base alla misura dello scatolato all'interno del quale vanno montate le ruote stesse.

Code	Desc.	B mm	F x L
2970014510	131/60	44	M16x60
2970014520	131/90	74	M16x90

## Ruote con supporto per cancelli gola a "V"

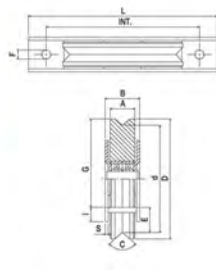

- Ruote in acciaio C45 tropicalizzato, fissaggio tramite supporto con fori, cuscinetto singolo, gola per guide a V.

Int. x F mm	Payload kg
117x9	190

5

## Ruote con supporto per cancelli gola tonda

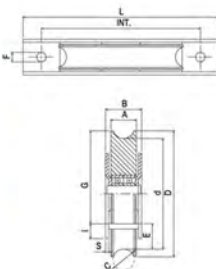

- Ruote in acciaio C45 tropicalizzato, fissaggio tramite supporto con fori, cuscinetto singolo, gola per guide rotonde.

Code	Desc.	D mm	d mm	A mm	B mm	C mm	G (mm)	I mm.	E mm	S mm	L mm	Int. x F mm	Payload kg
2970014560	133/80	80	61	26	34	21	59	11	17	2,5	140	117x9	190
2970014570	133/100	100	81	26	34	21	69	11	27	2,5	140	117/9	240
2970014580	133/120	120	101	26	34	21	88	14	21	3	186	150x9	270

## Ruote con supporto per cancelli gola tonda doppio cuscinetto

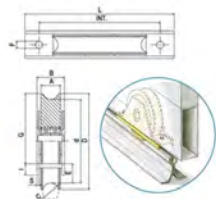
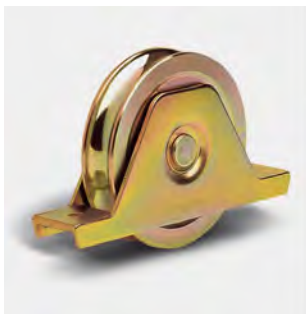

- Ruote in acciaio C45 tropicalizzato, fissaggio tramite supporto con fori, cuscinetto doppio, gola per guide rotonde.

Code	Desc.	D mm	d mm	A mm	B mm	C mm	G (mm)	I mm.	E mm	S mm	L mm	Int. x F mm	Payload kg
2970015100	161/90	90	70	26	34	21	58	12	11	2,5	140	117x9	300
2970015110	161/100	100	80	26	34	21	68	12	21	2,5	140	117x9	340
2970015120	161/120	120	100	26	34	21	88	14	21	3	185	151x9	430

## Arresto di fine corsa a saldare

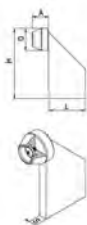

- Arresto di fine corsa per cancelli scorrevoli, interamente in acciaio zincato e tampone paraurti in gomma. Fissaggio a saldare.

Code	Desc.	D mm	L mm	H mm	A mm	S mm
2970014590	134	30	50	95	23	8

5

## Arresto di fine corsa con fissaggio a pavimento

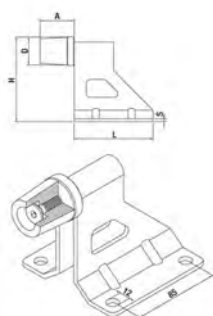

- Arresto di fine corsa per cancelli scorrevoli, interamente in acciaio zincato e tampone paraurti in gomma. Fissaggio a pavimento con ancoranti.

Code	Desc.	D mm	L mm	H mm	A mm	S mm
2970014600	135	40	110	120	45	4

## Cremagliera zincata 30X12 con asole

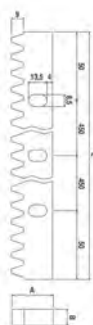

- Cremagliera in acciaio per movimentazione di cancelli scorrevoli. Sezione rettangolare 30 X 12 mm, lunghezza 1 m, dotata di fori asolati per il fissaggio tramite gli appositi distanziali.

Code	Desc.	Finishing	A mm	B mm	L m
2970014610	136	Zincata	30	12	1,0

## Distanziale a saldare per cremagliera

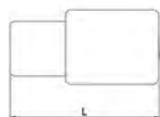

- Distanziale in acciaio zincato specifico per il montaggio delle cremagliere asolate. Fissaggio a saldare.

Code	Desc.	L m
2970014620	137	25

## Rulli di guida in nylon cilindrici



- Rulli di guida in nylon per cancelli scorrevoli. Perno filettato in acciaio zincato con doppio dado per il fissaggio.

Code	Desc.	D mm	H mm	L mm	F
2970014630	138/25	25	40	71	M14
2970014640	138/30	30	40	71	M14
2970014650	138/40	40	40	73	M14

## Piastra di guida regolabile zincata



- Piastra di guida in acciaio zincato regolabile per cancelli scorrevoli. Dotata di quattro rulli in nylon.
- Fissaggio dei rulli su asole per la regolazione della larghezza. Fissaggio a montante tramite ancoranti con asole per la facile regolazione della posizione durante il montaggio.

Code	Desc.	A min/max mm	b mm	B mm	Ø rulli mm	High rollers mm	Loops mm	E mm	D mm	H mm	L mm
2970014660	139	0-90	70	110	30	40	30x10	85	145	220	175

## Incontro superiore per cancelli scorrevoli regolabile con rulli di guida

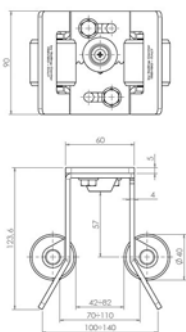

- Incontro fine corsa per cancelli scorrevoli, regolabile in larghezza da 40 ad 80 mm. Dotato di rulli di guida in acciaio per evitare rumorosità ed usura in fase di chiusura.
- Interamente in acciaio zincato, fissaggio tramite viti.

Code	Desc.	A mm	I x I mm	L mm
2970015130	162	40-80	20x60	60

## Incontro superiore per cancelli scorrevoli regolabile

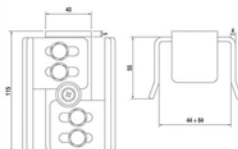

- Incontro superiore per cancelli scorrevoli costruito interamente in acciaio zincato, con tampone in gomma per fine corsa.
- Possibilità di regolare la larghezza in base alla sezione del tubolare con cui è costruito il cancello, da minimo 44 mm a massimo 84 mm.

Code	Desc.	Larg. min/max mm
2970015180	165	44-84

## Carrelli a due ruote per monorotaia

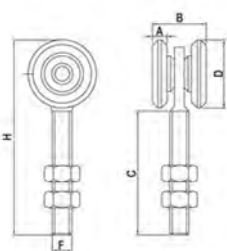

- Carrelli in acciaio zincato con doppia ruota su cuscinetto per scorrimento su monorotaia.
- Perno di fissaggio filettato con doppio dado.

Code	Desc.	D mm	A mm	B mm	H mm	FxC	Payload kg
2970014670	140/24	24	6	25	62	M8x35	40
2970014680	140/42	42	9	33	115	M12x60	150
2970014690	140/55	55	11	41	150	M20x77	170

5

## Carrelli a quattro ruote per monorotaia

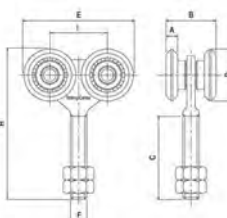

- Carrelli in acciaio zincato con quattro ruote su cuscinetto per scorrimento su monorotaia.
- Perno di fissaggio filettato con doppio dado.

Code	Desc.	D mm	A mm	B mm	H mm	FxC	Payload kg
2970014700	141/24	24	6	25	61	M8x35	110
2970014710	141/42	42	9	33	115	M12x60	180
2970014720	141/55	55	11	41	150	M20x77	200

## Maniglia dritta tropicalizzata e verniciata

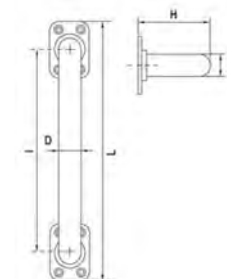

- Maniglia dritta in tubolare di acciaio tropicalizzata e verniciata a polvere epossidica per esterni.
- Fissaggio tramite piastre forate.

Code	Desc.	D mm	I mm.	H mm	L mm
2970014730	142/180	20	180	66	230

## Maniglia ad incasso per portoni

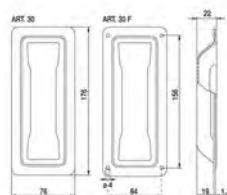

- Maniglia in acciaio zincato per portoni, montaggio ad incasso. Fissaggio tramite viti con fori predisposti sui bordi.

Code	Desc.
2970014740	143



## Cerniera a due ali in acciaio inox

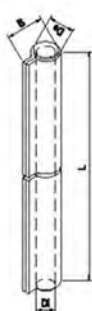

- Cerniera in acciaio inox a due ali chiuse, montaggio a saldare. Perno sfilabile e rondella in acciaio.

Code	Desc.	L mm	B mm	DE mm	Di mm
2970014750	144/80	80	16,5	12	8
2970014760	144/100	100	18	13,5	8,5

## Catenaccio ad avvitare, asta tonda e portalucchetto

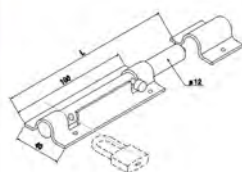

- Catenaccio pesante in acciaio inox con fori per il fissaggio, completo di incontro.
- Asta di chiusura rotonda diametro 12 mm, foro per chiusura tramite lucchetto.

Code	Desc.	L mm
2970014770	145/150	150

## Maniglia dritta in acciaio inox

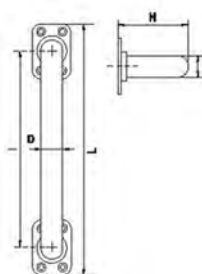

- Maniglia dritta in tubolare di acciaio inox.
- Fissaggio tramite piastre forate.

Code	Desc.	D mm	I mm.	H mm	L mm
2970014780	146/180	20	180	66	230

5





## Consumables

Brushes and brushes . . . . .	pag. 652	Cloths, sponges and general cleaning . . . . .	pag. 678
Insulating and packaging tapes . . . . .	pag. 655	Filters and fuel pipes . . . . .	pag. 695
Masking systems . . . . .	pag. 668	Lifting and anchoring systems . . . . .	pag. 704

## Flat paintbrushes



- Brush with blond bristles for general work.
- Flat paintbrush.
- Hollow plastic handle.

Code	Description	Brush width mm	Bristle height mm
4430033900	385-40	40	44
4430033910	385-50	50	51
4430033920	385-60	60	51
4430033925	385-80	80	57
4430033930	385-100	100	57

## Professional flat paintbrushes



- Extra professional paintbrush for universal use
- Flat paintbrush with blond bristles
- Wooden handle with two-coloured painted finish

Code	Description	Brush width mm	Bristle height mm
4430058240	1783-20	20	51
4430058245	1783-30	30	51
4430058250	1783-40	40	57
4430058255	1783-50	50	64
4430058260	1783-60	60	64
4430058265	1783-70	70	64

## Flat nylon paintbrushes



- Flat paintbrush with nylon fibre bristles
- Rough wooden handle
- Suitable for adhesives and paint strippers

Code	Description	Brush width mm	Bristle height mm
4430058270	1784-30	30	60
4430058275	1784-40	40	60
4430058280	1784-50	50	60
4430058285	1784-60	60	60

## Cylindrical brushes



- Brush with blond bristles
- Plastic ferrule and handle.
- Suitable for solvent-based paints

Code	Description	Ø pennello mm	Bristle height mm
4430033950	386-8	8	44
4430033960	386-12	12	44
4430034000	386-16	16	51
4430034010	386-18	18	57



## Radiator brush



- Flat paintbrush with blond bristles
- Wooden handle and bent ferrule.
- Use on radiators and for cutting in in hard to reach places

Code	Description	Brush width mm	Bristle height mm
4430058300	1785-30	30	51
4430058310	1785-40	40	57
4430058320	1785-50	50	64

## PVC block brush



- Block brush with PVC fibre

Code	Description	Measure cm	Bristle height mm
4430058330	1786-3x7	3 x 7	64
4430058335	1786-3x12	3 x 12	64
4430058340	1786-5x15	5 x 15	65

## Multipurpose block brush



- Block brush with blond bristles

Code	Description	Measure cm	Bristle height mm
4430058350	1787-3x7	3 x 7	70
4430058360	1787-3x12	3 x 12	70
4430058370	1787-5x15	5 x 15	76

## Perlon roller sleeves



- White Perlon fabric roller sleeves
- Solvent-resistant
- Recommended for paint and gloss paints

Code	Description	Ø Esterno mm	Altezza tessuto mm
4430058380	1788-Perlon roller 5cm	39	12
4430058390	1788-Perlon roller 10cm	39	12



## Sponge roller sleeves



- White moltopren sponge roller sleeves
- Extra-fine porosity
- Suitable for water-based gloss

Code	Description	Ø Esterno mm	Altezza tessuto mm
4430058400	1789-Sponge roller 5cm	35	10
4430058410	1789-Sponge roller 10cm	35	10

## Velour roller sleeves



- Velour fabric roller sleeves
- Ecu colour
- Suitable for all gloss paints. Solvent resistant

Code	Description	Ø Esterno mm	Altezza tessuto mm
4430058420	1790-Velour roller 5cm	23	4
4430058430	1790-Velour roller 10cm	23	4

## Roller handles

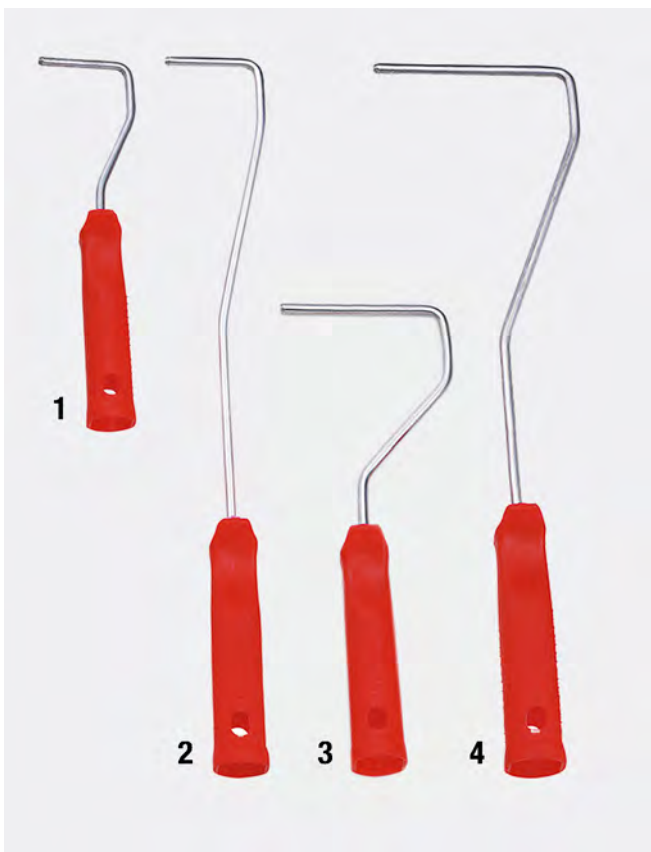

- Ergonomic roller handle
- Metal rod, diameter 6 mm
- Thermoplastic handle
- Essential for using sleeves with a 6 mm central hole.

Code	Description	Photo	Per rullini
4430058440	1791-Short frame x 5cm	1	5 cm
4430058450	1792-Long frame x 5 cm	2	5 cm
4430058460	1793-Short frame x 10cm	3	10 cm
4430058470	1794-Long frame x 10cm	4	10 cm

## Insulating tape Meccanocar



- Duct tape adhesive PVC self-extinguishing.
- Suitable for different uses, including: insulate cables, terminals, connectors and electrical contacts, create wiring and dressings of quality '.
- Article suitable for use in electrical civil and industrial, maintenance sector, elettrauto, mechanical, bodywork, automotive, etc ..
- The high property 'and elastic adhesive tape are preserved both in winter and in summer.
- Available in different colors for the identification of the different cable harnesses or electrical contacts.
- Excellent stability, elasticity ', aging resistance, abrasion, weathering, alkalis.
- Tape thickness 0.15 mm.
- Meets CEI EN 60454.

Code	Desc.	Width mm	Length mt	Color
4060008000	30/15X25	15	25	BLACK
4060008010	30/19X25	19	25	BLACK
4060008020	30/15X10	15	10	BLACK
4060008240	36/50x25	50	25	BLACK
4060008050	31/19X25	19	25	GREY
4060008060	31/15X10	15	10	GREY
4060008080	32/19X25	19	25	RED
4060008090	32/15X10	15	10	RED
4060008110	33/19X25	19	25	BLUE
4060008120	33/15X10	15	10	BLUE
4060008140	34/19X25	19	25	WHITE
4060008150	34/15X10	15	10	WHITE
4060008170	37/19X25	19	25	YELLOW / GREEN
4060008180	37/15X10	15	10	YELLOW / GREEN
4060008190	35/19X25	19	25	BROWN
4060008200	35/15X10	15	10	BROWN
4060008220	36/19X25	19	25	YELLOW
4060008230	36/15X10	15	10	YELLOW
4060008240	36/50X25	50	25	BLACK

## Kit tape Meccanocar



EN60454

- Assortment tape adhesive PVC self-extinguishing.
- Complies with cei en 60454.
- Suitable for use in electrical civil and industrial, maintenance sector, elettrauto, mechanical, bodywork, automotive, etc.
- Total pieces: 10 pcs.

Code	Description
4060008300	19900

CONTENUTO KIT:

CODICE	DESCRIZIONE	QUANTITA'
406 00 08010	30/19X25-NASTRO ISOLANTE NERO	3
406 00 08050	31/19X25-NASTRO ISOLANTE GRIGIO	1
406 00 08080	32/19X25-NASTRO ISOLANTE ROSSO	1
406 00 08110	33/19X25-NASTRO ISOLANTE BLU	1
406 00 08140	34/19X25-NASTRO ISOLANTE BIANCO	1
406 00 08170	37/19X25-NASTRO ISOLANTE GIALLO/VERDE	1
406 00 08190	35/19X25-NASTRO ISOLANTE MARRONE	1
406 00 08220	36/19X25-NASTRO ISOLANTE GIALLO	1

6

## Tape insulating fabric



- Adhesive tape "rayon", used for insulation of electrical wiring car-motorcycle
- High qualities of adhesion and unwinding easier for agile application manual
- IMPORTANT: Apply the tape on dry, clean and free from grease.

Code	Desc.	Dimensions	Color
4060002800	19272	25 mt x 19 mm	BLACK

Tecnical Features	
Temperatura massima d'esercizio	°C 70
Adhesion to the plate	g./cm 400
Adhesion to the unreeling	g./cm 300
Lengthening at breaking	% 10
Breaking strength	Kg/cm <sup>2</sup> 7
Tipo di supporto	Rayon
Spessore nominale	mm 0.28

## Insulating tape Felt



- Tape of polyester felt, with acrylic-based adhesive used for the isolation of electrical wiring cars, motorcycles and trucks.
- This coating also avoids the noise due to sliding and vibration of the cables, it is therefore excellent for use inside vehicles.
- IMPORTANT: Apply the tape on dry, clean and free from grease.

Code	Desc.	Dimensions	Color
4060002950	19274	25 mt x 19 mm	BLACK

Tecnical Features	
Resistenza alla temperatura	°C/h 125-500
Weight	g./cm <sup>2</sup> 220
Tipo di supporto	Polyester felt
Spessore nominale	mm 1
Breaking strength	Kg/cm <sup>2</sup> 4
Adhesion to the plate	g./cm 400
Lengthening at breaking	% 50

## Self-amalgamating tape



- Self-amalgamating tape EPR (ethylene propylene rubber), used to repair and splice the power cables, reconstructing the primary isolation.
- Excellent sealing and excellent resistance to weathering and ultraviolet rays.
- **WARNING:** This product is not a tape. Its peculiarity is that, once applied, autoagglomerarsi transformed within minutes into a compact mass.
- Also excellent for use as a resetting of water pipes, in marine, motor sports, gardening, etc ..

Code	Desc.	Dimensions	Color
4060003000	19274	9.1 mt x 19 mm	BLACK

Tecnical Features	
Potere autosaldante	Excellent
Resistività di volume	Ohm/cm 1015
Rigidità dielettrica	Kv/mm 35
Lengthening at breaking	% 1.000
Breaking strength	Kg/cmq 10
Maximum load	Kg/cmq 20
Spessore nominale	mm 0.75
Tipo di supporto	EPR rubber

## Tape aluminum foil



- Aluminum tape thickness 30 microns with acrylic adhesive and silicone paper liner.
- Excellent conformability, adhesion and high temperature performance.
- Mainly used in the refrigeration industry, in air conditioning, ventilation systems and in any application where it is necessary an adhesive tape with good characteristics of thermal conduction is to isolate that to seal.
- Excellent resistance to heat, cold and moisture.

Code	Desc.	Dimensions
4060003100	19275	50 mt x 50 mm

Tecnical Features	
Spegnimento delle gocce	0
Temperatura massima di utilizzo	°C -20/+50
Temperatura di applicazione	°C 0/+40
U.L. according classification	-
Velocità di propagazione della fiamma	5
Sviluppo dei fumi	0
Adhesion to the plate	g./cm 400
Adhesion to the back	g./cm 450
Lengthening at breaking	% 5
Tipo di supporto	Aluminum foil 30 microns
Spessore nominale	Micron 60
Breaking strength	Kg/cm 1.2

## Packaging tape for PPL and PVC



- Tapes in recyclable polypropylene.
- Excellent closing, quick and quiet.

Code	Description	Formato	Color
4060400100	PPL-BEIGE	mm50x66m	BEIGE
4060400150	PPL-WHITE	mm50x66m	WHITE
4060400160	PPL-TRASPARENT	mm50x66m	TRASPARENT
4060400700	PVC BEIGE	mm50x66m	BEIGE

## Taping manual



- Taping manual rolls h 50 mm.
- With adjustable brake.

Code	Description
4060400600	TAPING MANUAL

## Saldanastro (Nastro Americano)



- Cloth tape coupled with PE.
- Ultra-strong tape with excellent adhesion.
- Excellent heat resistance: 100 ° continuously.
- Indicated for sealing ducts.
- For temporary repairs of sleeves.
- For the joining of materials phono and thermo insulation.
- Excellent impermeability.

Code	Description	Dimensions
4060600090	2550-WELDING TAPE	H mm50x25m
4060600091	2551-WHITE	H mm50x25m



## Reinforced cloth tape for high temperatures



- Nastro telato ideale per carrozzieri
- Adesività 10 (N/25 mm), rimovibile fino a 30gg
- Resiste all'acqua
- Resiste raggi UV
- Resistenza al calore 93°C
- Ottima malleabilità
- Non lascia colla
- Utilizzato nelle operazioni di delimitazioni di parti di carrozzeria che devono essere sabbiate o levigate o trattate con abrasivi
- Utilizzato nelle operazioni di montaggio dei parabrezza.

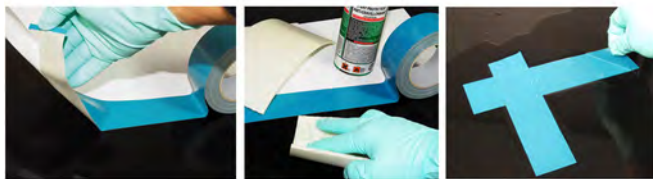

Code	Description	Measures L x H mm	Body color
406060095	2555-NASTRO X CARROZZIERI H 50 X 25 M	25 X 50 MM	AZZURRO
4060002600	19270 - Duct Tape 27x19 mm	27 x 19 MM	Black
4060003200	19276 - Duct Tape 25x50 m	25 x 50 MM	Black

## Double-sided foam tape for moldings

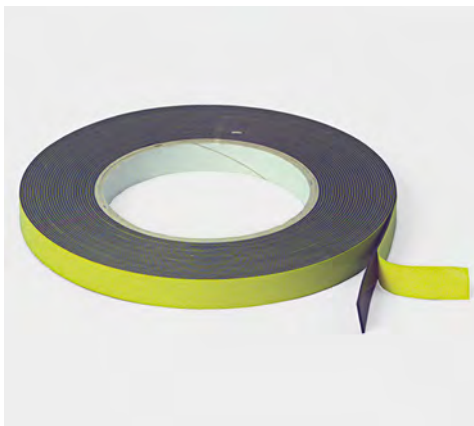

- Double-sided tape in expanded polyethylene foam, black, with acrylic-based adhesive in solvent.
- Suitable for applications of plastic profiles, plates, emblems and for uses in the automotive industry in general.
- High compressive strength, oils, plasticizers, UV and moisture '.
- Time of application immediate.

Code	Desc.	Color	h mm	L m
4060700050	2518	BLACK	6	10
4060700100	2519	BLACK	12	10
4060700120	2520	BLACK	19	10

Technical Features	
Resistenza alla temperatura °C	-20/+100
Adhesion to steel N/cm. AFERA 4001	13+/-2
Spessori ad. + supp. Micron PSTC 5	850+/-150
Density Kg/m3	200

## Double-sided tape for carpet



- Double-sided tape in thin plastic film, with synthetic rubber adhesive, white color.
- Used especially in the application of carpet on the floors and in the auto industry.
- It adheres well to all substrates, such as tiles, ceramics, wood, metal, etc., Good tear resistance, easy detachment.
- CHARACTERISTICS:
- Adhesiveness' steel (PEEL) N / cm .: 7 +/- 1.
- Micron thickness: 145 +/- 5.
- Tensile strength N / cm .: 55 +/- 5.
- Elongation at break%: 600.
- Temperature resistance ° C -10 / + 60.

Code	Desc.	Height mm	Length m
4060700150	5019	19	25
4060700200	5025	50	25

6

## Invisible adhesive tape acrylic double-sided transparent multipurpose



- Acrylic double-sided adhesive tape perfectly transparent high-performance, multi-purpose.
- Ideal for the invisible fixing of transparent parts in plastic PC-PMMA normal or glass, or in any condition where it is not possible to use a fastening of the mechanical type.
- Perfect for fixing the door mirror on the windscreen of the vehicle interior.
- Ideal in the automotive sector for the fixing of moldings and other details of finishing, fastening of interior panels. In the construction sector or plant it can be used for any fastening on glass, metal or wood.
- Before use, make sure the surfaces to be bonded are clean, dry and free of grease, oil, rust and dust.
- Roll size: height 25 mm., 0.5 mm thick. length 3 mt.

Code	Desc.	Dim. L.xH. Mm
4060700400	7025	3000x25

Tecnical Features	
Peeling su acciaio a 23°C	> 10 minutes
Lengthening at breaking	> 800%
Resistenza alla temperatura	-40/+150°C
Base	Acrylic adhesive on PE liner
Spessore adesivo	0,5 +/- 0,1 mm.
Color	Transparent

## Double-sided foam tape to mirrors and vertical applications



- Double-sided tape in expanded polyethylene foam with acrylic adhesive emulsion.
- Suitable for all vertical applications, in particular of glass, mirrors, metals and plates.
- Excellent resistance to oils, plasticizers, solvents, UV rays and humidity '.
- CHARACTERISTICS:
- Density 'kg / m3: 100.
- Thicknesses to. + Media. microns PSTC 5: 850 +/- 150.
- Adhesiveness' steel N / cm AFERA 4001: 10 +/- 1.5.
- Temperature resistance ° C -10 / + 100.

Code	Desc.	Height mm	Length m
4060700300	6025	25	25

## Self-adhesive tape anti-slip



- Black non-slip tape with acrylic adhesive high held.
- Very good friction coefficient.
- Silicone paper liner.
- Flexibility 'up to 90 °.
- Outdoor durability: over 2 years.
- Resistant to temperatures from -30 ° C to 110 ° C.
- It is commonly used on steps, stairs, floors of means of locomotion and transport, caravans, tractors, trucks, etc.

Code	Desc.	Measures
4460007800	4033	H25mmx18m
4460007850	4033/50	H50mmx18m

## Paper tape for masking



- Lightly crepe paper adhesive tape.
- Masking industry powered vehicles.
- In particular this adhesive ensures ease of removal after use without the release of waste even when subjected for a period of time at a temperature up to 80 °.
- Is also used in painting and civil negl the graphic studies as removable tape.
- Being removed leaves no residue.

Code	Desc.	h mm	L mm
4060100100	10	19	50
4060300090	25	25	50
4060300100	38	38	50
4060500100	50	50	50

## Paper tape for gaskets



- Special tape in paper with rib in plastic material suitable for the masking of the window seals during painting.
- Simple use, easy detachment and no release of mastic even if subjected to high temperatures for long periods.
- Rigid rib height 15mm.

Code	Desc.	h mm	L m
4060300300	40G	40	10

6

## Transfer to friezes



- New system of double-sided adhesive fastening controlled transfer, for bonding friezes emblems and all the details that must be positioned before bonding definitive.
- It replaces normal tapes, peel the glue automatically transfers only on the contact details to be fixed. It shapes alone.
- Exceptionally resistant to weather and temperatures. The thermal resistance is from -30 ° C to + 180 ° C.
- Packaged in strips 50x300 mm dimensions.



Code	Desc.	Dim. mm	N. Pieces
4110011900	2705	50 x 300	10



## Adhesive Velcro type telepass



- Adhesive fasteners, of the type used for fixing to the glass of the toll.
- The fastening system, in contrast to the normal scotch Velcro, and 'based on the principle of closure of the teeth on themselves, and allows not to have a male part and a female. The adhesive is formed by a single part that sticks on itself in both longitudinal and transverse directions.
- The force that joins the two pieces of tape is very strong, it can be closed and reopened many times, and acrylic adhesive on the board allows adherence to surfaces.
- Easily cut to size, cost, the strong hold for each attachment that can be easily removed.

Code	Desc.	Length <i>m</i>
4720023160	2051	2

Technical Features	
Spessore mm	5,9 ca.
Forza di chiusura n/cm2	15-25
Adhesiveness N/cm2	25-35
Color	Transparent

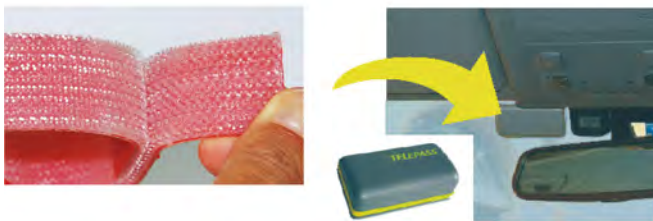

## Adhesive shaped "dual lock" for Telepass



- Convenient adhesive stretch "Dual Lock" pre-cut for installation in glass of Telepass, parts of the original that came with the device. Useful any time for any reason it should be replaced.
- Suitable for all centers windshield replacement, the car body, the body of transformation vehicles.
- Strong grip adhesive acrylic type, system-off for hooking-quick release device.

Code	Desc.
4060008350	41



## Velcro male + female



- Colore bianco.
- Colore nero.
- Base adesiva.

Code	Desc.	Dimension <i>height x leng.</i>	Color
4720018796	789/1B	20mmx25m	White
4720018797	789/2B	25mmx25m	White
4720018798	789/3B	50mmx35m	White
4720018791	789/1N	20mmx25m	Black
4720018792	789/2N	25mmx25m	Black
4720018793	789/3N	50mmx35m	Black



Base adesiva



Tipo tenace

6

## Pluriball - film packaging



- Polyethylene film with air bubbles.
- FEATURES AND ADVANTAGES: Suitable for the packaging of products that need protection from dirt, scratches and bumps during transport and storage.
- It ensures maximum protection to fragile, shiny surfaces and painted, semi-finished mechanical parts, etc ..
- Weight 70g / m2.

Code	Desc.	Height mt	Length <i>mt</i>
4440003400	15870	1,25	100
4440003410	15872	1	100
4440003450	15891	2	200

## Stretch film for packaging



- Stretch film 100% recyclable. Disposed with domestic waste.
- Non-toxic product guaranteed.
- In low density polyethylene at 100% (LLDPE).
- Knob supplied separately
- Ideal for creating packaging, to wrap pallets, objects, artifacts.
- Benefits: 500% elongation.
- The white film and 'suitable for the protection of the goods by the ultraviolet rays.
- Black or white film to cover teasels merchandise.

Code	Description	H mm	Ø int. mm	Each weight coil Kg	Spessore micron	Color
4440001020	11040	500	50	2,6±5%	23	TRANSPARENT
4440003420	15880	500	50	2,2±5%	20	TRANSPARENT
4440003430	15885	500	50	2,4±5%	23	WHITE
4440003440	15890	500	50	2,4±5%	23	BLACK
4440001030	11050 - KNOB 2 PIECES FOR FILM H500	-	-	-	-	-

## Stretch film multipurpose



- Stretch film 100% recyclable.
- Non-toxic product guaranteed.
- In low density polyethylene at 100% (LLDPE).
- Thickness 23 microns
- Roll 125x100 meters. - Tube int. ø 38 mm.
- Elongation 500%.
- Knob provided separately.



Code	Desc.	Type
4440001000	11020	STRETCH FILM
4440001010	11030	KNOB

## Polypropylene strapping for manual use



- Polypropylene strapping for manual use
- Polypropylene strapping 100% to pack and wrap products and packages during transport.
- Intended for all customers who warehousing, storage and shipment of goods.
- Elastic recovery: 90-95%.
- Tolerance: +/- 5%.
- Elongation: 10-15%.
- Temperature range -20 to + 60 ° C.
- Supplied on a reel, inner diameter 392 mm.
- Black Colour.

Code	Desc.	Width mm	Thickness mm	Length m
4430055650	1390	12	0,6	2500
4430055655	1395	15	0,8	1500

6

## Strapping manual universal



- Strapping tools for manual holding of a width of 12 to 15 mm.
- Cast aluminum construction with steel levers and mechanism completely.
- Minimum effort of draw, and weight of 3 kg.

Code	Desc.
4430055665	1405

## Seals for strapping

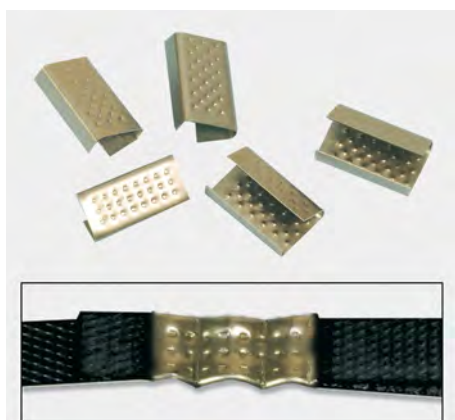

- Seals steel for closing the holding. Universal use with all models of strapping tools manuals.
- High clamping force and safety of the closure.

Code	Desc.	For straps width
4430055670	1410	12 mm
4430055675	1415	15 mm

## Shopping reel for straps



- Carriage with disc locking plate.
- Construction in painted steel, with drawer seals.
- For reels with internal diameter 392 mm.

Code	Desc.
4430055660	1400

## Bende per riparazioni di emergenza "Fasten&Fix"



- Benda in gomma neoprenica e velcro creata per risolvere situazioni d'emergenza senza la necessità di chiudere il passaggio dei fluidi tipo acqua, olio o similari dalle tubazioni rotte. La benda resiste a pressioni fino a 10 bar e temperature fino a 120°C.
- In caso di emergenza basta avvolgere strettamente la benda intorno alla rottura, fino alla fine del nastro fissando tutto con il velcro su se stessa. La tenuta è assicurata all'infinito e la benda, una volta fatta la riparazione, può essere riusata infinite volte.
- Indicata per chi lavora nel settore idrosanitario, ma anche elettrico, nell'edilizia, nel settore meccanico. La portata e la resistenza della benda gli permettono di essere usata anche per fissaggi e trasporto di materiale, come maniglia di emergenza, per fissaggio di carichi sfusi, per tenere insieme materiali durante le varie lavorazioni, ecc.
- Disponibili in quattro misure per tubazioni di diametro da 10 mm fino a 220 mm distinguibili fra loro dal diverso colore.



Code	Desc.	Color	Capacity mm
4060008400	42	Rosso	10 - 30
4060008410	43	Giallo	30 - 70
4060008420	44	Verde	70 - 160
4060008430	45	Bianco	160 - 220



## Curb foam adhesive



- Curb spongy foam adhesive suitable for masking the cracks of vehicle bodies during painting.
- The shape and flexibility allow the perfect fit into the slots, and prevents the penetration of dust inside during the spraying.
- Available in different sizes to fit the size of the joints by close.

Code	Desc.	Diam. mm	Roll length
4460010090	4342	13	50 MT
4460010100	4343	19	50 MT

6

## Edging foam adhesive "T"



- Edging foam for masking of slits on the bodywork of motor vehicles, it allows not to allow paint to penetrate into the joints between the plates and to obtain a detachment precise and perfect in the simplest way possible.
- Designed for painting operations in car body of cars of each type.
- The special shape of "T" with adhesive on the back makes installation easier and faster compared to normal curbs round, and a degree of surface finish with no cuts or steps on the paint.
- Measuring only in dispenser boxes of 25 meters.

Code	Description	Length m
4460000960	2627	25



## Paper masking



- Paper masking of the classical type "kraft", waterproof paints also to water and solvents.
- Suitable for all the operations of masking before painting in bodywork.
- Grammage 40 g / m<sup>2</sup> +/- . Brown color, with a smooth side and one rough. On our wall mountable holder until H 85 cod. 446 00 01800-3953.

Code	Desc.	Height cm	Length <i>m</i>
4460002400	3959	10	200
4460001500	3950	30	200
4460001600	3951	45	200
4460002500	3960	60	200
4460001700	3952	85	200
4460000910	2622	100	200
4460000920	2623	120	200

## Coated paper for masking



- Masking paper white kraft coated on one side, it is waterproof to paints, also water, and the lenses.
- Suitable for all the operations of masking before painting in bodywork.
- Grammage 40 g / m<sup>2</sup> +/- 2. White color. To avoid peeling paint at the time of removal, it is recommended to be painted on the side not covered.

Code	Desc.	Height cm	Length <i>m</i>
4460000930	2624	60	150
4460000940	2625	85	150
4460000950	2626	100	150

## Roll holder Wall Paper masking



- Roll holder in painted sheet.
- Rolls capabilities: h 10 cm - h 60 cm - h85cm.
- Holder with the system that allows to apply the tape adhesive paper n / s art. 406 01 10 00100-h19 on paper.

Code	Desc.
4460001800	3953

## Polyethylene sheet HD masking



- Towel for masking polyethylene HD (high density), with external treatment for paint adhesion, even to water, and transparent. Absolute absence of passage within paint. Electrostatic canvas that adheres only to the surfaces facilitating the work of masking.
- Ideal for work masking bodywork, and for coating booths.
- The paint does not come off and does not flake during removal. Suitable for drying in the oven or by means of UV lamps. Transparent color for precise cutting edge.
- Supplied in a protective box. Roll width 96 cm, with cardboard core, for inclusion in any holder of any brand.

Code	Desc.	Dimension in m. <i>Width X Length</i>
4440001605	13300	4 x 250
4440004190	16190	5 x 150

6

## Film rolls



- Rolls of film on paper tape backing, 22 mm
- Ideal for coverage before painting
- With treatment for adherence to paint
- Areas of use: bodywork, paint stations, painters and decorators, and boatbuilding sector,
- Resistant up to 80°
- Film thickness 10 my

Code	Description	h roll cm	Dimensions
4440102025	450/60-Film roll 60cm x20m.	10 cm	cm.60x20m
4440102030	450/90-Film roll 90cmx20m.	20 cm	cm.90x20m.
4440102035	450/120-Film roll 120cmx20m	20 cm	cm.120x20m.
4440102050	450/270-Film roll 270cmx16m	20 cm	cm270x16m

## Roll dispenser



- Equipment for easy use
- Used to pull out, position and cut the film.
- In plastic material

Code	Description
4440102060	451/10 Roll dispenser h10
4440102065	451/20 Roll dispenser h20

## Shopping for masking towels in dispenser



- Steel trolley for positioning and the easy portability of the dispenser boxes of towels polyethylene masking.
- Painted steel, particularly robust, with large wheels for easy handling.

Code	Desc.	Dimensioni in cm. <i>Width x height x depth</i>
4440004220	16220	105x70x73

## Mini "Cutter" for the cutting of the cloth HD



- Mini cutter to cut to the desired size towel in HD.
- Plastic material with angled blade for increased cutting efficiency.
- Pack of nr. 5 pieces.

Code	Desc.	Measures (mm)
4440001609	13355	70x53

## Parking sensor protection



- Easy to apply.
- Fits most sensor types.
- Serves to paint and sand over sensors.
- 18 mm diameter
- Serves to cover parking sensors during sanding and painting operations.
- The special shape means the product can be removed easily, with no paint drips, covering the sensors quickly and effectively for excellent finished results.

6

Code	Description
4460042360	Parking sensor protection

## Masking polyethylene for rims



- Masking polyethylene preformed to protect the tires and simple painting of car rims.
- Suitable for all body shops and paint industries, tire shops, etc ..
- Pre-cut into pieces already separated, the high elasticity of the material allows the protection, once deflated and stallonata the rubber, fit perfectly on the edge of the circle, and adhere to the perimeter of rubber for a perfect masking the paint and fumes painting.
- Huge time savings, the masking of the tires is carried out in about 2 minutes against the 15 required with conventional methods (paper or polyethylene sheet). Suitable for steel wheels and alloy wheels with diameters up to 22 ".
- Supplied in a practical dispenser box cardboard. the single piece open has dimensions of 1300 x 1300 mm. Available on request a wall support in painted steel for positioning the most 'practical.

Code	Desc.	Article
4440004200	16200	Dispenser box of 80 pieces 1300x1300 mm
4440004210	16210	Support wall painted

## Steering wheel cover and cover transmission in TNT



- Material: TNT (nonwoven fabric).
- Practical steering wheel cover and cover change.
- In addition to protecting the steering wheel and the gear lever from any type of dirt, add value to your business, as they attest to the care you have had for the cars of your clients.
- TNT gives the articles softness, elasticity and resistance.
- In particular, the cover transmission presents an elasticity sealing under the head of the gearbox that prevents it from slipping off.
- Both equipped with seams along the edges to ensure high durability.

Code	Desc.	Article
4440001700	14000	Steering wheel cover
4440001750	14050	Cover Transmission



## Seat covers neutral



- Material: Polyethylene.
- Practices seat covers neutral transparent material.
- Thickness: 20 microns.
- Particularly suitable for body shops and workshops.
- Flexible, lightweight and resistant to abrasion.
- In addition to protecting the seat from any type of dirt, add value to your business, as they attest to the care you have had for the cars of your clients.
- Dimensions: 1650 x 710mm.
- Not customizable.

Code	Desc.	Rips number-Cont.
4440100050	2/T	125 seat covers transp.
4440100105	2/1	250 seat covers White



## Foderine copriesedili Meccanocar



Code	Desc.	Content
4440100100	2	Bobina da 125 foderine

6

## Espositore murale Meccanocar



Code	Desc.
4440100250	25

## Set of disposable protective



- Characteristics:
- Set of protection for cars packed in disposable bags with everything needed inside.
- Seat cover, steering wheel cover, handbrake cover and cover transmission white polyethylene.
- Suitable for car workshops and industrial vehicles, bodywork, elettrauto, transformers vehicles, etc.
- The set consists of 100 envelopes each containing: 1 seat cover in polyethylene thickness 13 microns white, 1 steering wheel cover with elastic edge in polyethylene, a cover transmission edge stretch, a handbrake cover with elastic edge, a mat coated paper dimensions 50 x 37 cm.
- The packaging in single envelopes allows a better management of the material by the workshop and a saving of time and costs.
- Available a practical wall bracket in painted steel with epoxy.
- Box dimensions: 300 x 230 x 280 mm.
- Weight: 4.6 kg approx.

Code	Desc.	Article	Content pcs.
4440101900	393	Kit Protective Disposable	100
4440101910	394	Wall support	1

## Canvas magnetized



- Characteristics:
- Material: PVC.
- Color: black background.
- Extremely easy of application via magnet..
- The foam padding on the back allows you to work safely without the risk that the part in contact with the car may scratch the car body.
- The material is highly resistant, has a long durability of the cloth magnetized.
- Option to buy the towel with logo Meccanocar or neutral.

Code	Desc.	Color	Formato
4460002000	3955	Meccanocar	112x64 cm
4460002005	3955/0	Neutral	112x64 cm

## Copriparafango adesivo di protezione



- Bobina di foderine usa e getta in polietilene per proteggere i veicoli in officina e carrozzeria.
- Si applica tramite una banda adesiva su tutte le carrozzerie in plastica o alluminio.
- Il materiale del copriparafango non attira frammenti e polveri metalliche che potrebbero depositarsi sulle vetture.
- Ogni bobina e' composta da 100 strappi in polietilene bianco. Dimensioni strappo: 690x1090 mm. Dimensioni supporto murale: 745x 100 mm
- Personalizzazione: Con il logo del cliente fino ad un massimo di 6 colori; disponibili tutti i marchi automobilistici. In ogni strappo compaiono 2 ripetizioni del logo.

Code	Desc.	Rif.
4440101600	260	Generica

## Shelter sticker for goalkeeper



- Roll of cellophane multi-purpose adhesive, expressly studied for the containment of the glass cracked or broken during disassembly, to avoid that the splinters can fall inside the vehicles, with the consequent difficulties of cleaning, or may injure the operator.
- Excellent adhesion even on complex surfaces or curved.
- It can also be applied on fabrics and coatings of various nature without danger of damage during removal.
- It can also be used as a safety fixing of the side windows or rear windows on the way up to the engineer to avoid breakage or explosion during the journey.
- Ideal application for cover as moisture inside of the doors.

Code	Desc.	Dimensions
4060003300	19277	10 m X 60 cm

## Cellophane adhesive safety film



- Self-adhesive film with polyethylene foam for the under coating of front and rear doors of each type of vehicle.
- Product repositionable, resistant to moisture, water, dust, particularly suitable for the reconstruction of the shelters damaged during disassembly for repairs.
- The type of product in foam material is used in original equipment by several automakers, and therefore can reproduce the original finish.
- Highly conformable and can be cut in many different ways.
- Package of 60 cm high and 10 meters in total length.

Code	Desc.	Dim. LxH. cm
4460010350	4345	60x1.000

## Rags for cleaning



- Rags for general cleaning and maintenance.
- Supplied in various formats in small denominations.
- Made of cotton again.
- Highly absorbent.
- Scope: suitable for all types of customers.

Code	Description	Quantity
446PU00200	200-White rags	10 Kg
446PU00210	210-Colored rags	10 Kg

6

## Cloth for polishing



- Specific product for polishing metal operation
- Excellent on painted surfaces
- Cloth white
- Lint, leaves no residue,, then allows a perfect finish.
- The particular texture of the cloth allows the removal of excess wax.
- Supplied in boxes of 120 pieces

Code	Desc.	Formato cm
4460009800	4316	33X40

## Cloth T.N.T.



- Purpose cloth non-woven (TNT)
- Excellent resistance to cleaning mechanical parts.
- Suitable for operations of debinding and polishing
- Cloth white
- Supplied in boxes of 120 pieces

Code	Desc.	Formato cm
4460009810	4317	33X40



## Cloth antisilicone



- Cloth non-woven fabric (TNT)
- Ideal to spend the antisilicone before painting and sanding
- Suitable for all types of solvent
- Absorbs oil and grease
- Allows repetitive use for all cleaning jobs
- Supplied in box of 100 pieces.

Code	Desc.	Formato cm
4460009820	4318	33X40

## Cloth "Magic Clean"



- Microfiber material pearly 70% polyester - 30% polyamide.
- White color.
- Ideal for cleaning and dust.
- Useful for the truck, a car and a motorcycle.
- The particular structure that does not attack and does not alter the surfaces on which it is used.
- Lint and leaves no traces.
- Available sizes 40 cm x 40 cm.
- Machine wash up to 90 ° without fabric softener.

Code	Description	Color	Measures
4460004710	3982/1 MAGIC CLEAN 40X40	White	40X40 cm

## Cloth "Magic Drying"



- Ultra microfiber material 70% polyester - 30% polyamide.
- Light blue colour.
- High density and absorbency.
- Ideal for drying bodywork.
- Useful for the truck, a car and a motorcycle.
- The particular structure that does not attack and does not alter the surfaces on which it is used.
- Lint and leaves no traces of moisture.
- Available sizes 40 cm x 40 cm.
- Machine wash up to 90 ° without fabric softener.

Code	Description	Color	Measures
4460004720	3982/2 MAGIC DRYING 40X40	Light blue	40X40 cm

## Cloth "Magic Polish"



- Microfiber material sponged 70% polyester - 30% polyamide.
- Pink color.
- Ideal for polishing of bodywork.
- Useful for the truck, a car and a motorcycle.
- The particular structure that does not attack and does not alter the surfaces on which it is used.
- Lint and leaves no traces of moisture .
- Great job to polish the bodywork.
- Available sizes 40 cm x 40 cm.
- Machine wash up to 90 ° without fabric softener.



*Magic Polish*

Code	Description	Color	Measures
4460004730	3982/3 MAGIC POLISH 40X40	Pink	40X40 cm

6

## Microfiber cleaning glove



- Practical microfiber glove.
- Product suitable for body shops, car dealers, car wash, drivers, fuel distributors.
- The glove microfiber allows finishing work very quickly and effectively without altering the surfaces on which it is used.
- Lint and leaves no traces of moisture '.
- The glove microfiber can also be used for the cleaning of the window frame or in the machining of stainless steel.

Code	Desc.
4460021550	24450

## Kit Meccanocar Duster



- Product suitable for car dealerships and VI, showrooms, car bodies and car washes.
- Ideal for the cleaning and the total removal of the dust deposited on the bodywork and interiors.
- It allows you to deliver the means perfectly washed and polished with great savings of time and water. Compact, lightweight and easy to use.
- It reduces the number of washes.
- Fibers in 100% cotton, which ensure the total removal of the light dust.
- **CHARACTERISTICS:**
- Kit consists of a duvet and a great mini quilt suitable for interior cleaning.
- Do not scratch surfaces.
- It reduces the number of car washes.
- Supplied with a handy carrying case with port card.
- Not recommended for use on wet surfaces or for washing. Duvet large: 640 x 75 x 170 mm, 610 grams. Mini quilt: 310 x 100 x 160 mm, 150 grams.
- **HOW TO USE:**
- The quilts are to be used only on dry, not wet.
- Do not wash the duvet.
- Shake vigorously to release the collected dust.
- Use the mini duvet inside cabin only on non-porous surfaces, otherwise you should use the microfiber cloth cod. 4460004710 "Magic Clean".

Code	Desc.	Color	Length mini duster cm	Length duster cm
4460019500	19730	Green	310	640

## Synthetic leather



- Ideal for drying all kinds of surface

Code	Desc.	Dimension cm
4460003000	3965	48x37

## Real leather



- Ideal for drying all types of vehicle
- Excellent finish drying of body and glazed

Code	Desc.	Dimension cm
4460004700	3982	66x58
4460002200	3957	79x84

## Alcantara leather (microfiber)



- Microfibre cloth
- Great for a quick-drying
- Ideal on all vehicles
- NB: can change the color according to the supplies

Code	Desc.	Dimension cm
4460002300	3958	60x40

## Squeezer rollers



- Angle support for wall with holes  $\varnothing$  8mm (plugs not included)
- Screws with springs for the height adjustment of the rollers. rubber roller 35 cm
- Suitable for all skin types spremituraasciugatura
- Suitable for showrooms, dealers, body shops and car washes.



DIMENSIONI m			PESO
A	B	C	Kg
500	390	160	8

Code	Description
4430049890	973 - Wall squeezer
4430049892	973 R1 - Spare roll along lower
4430049894	973 R2 - Short upper roller replacement

## Glass washer dryer with handle



- Aluminum handle length 50 cm
- CM25 sponge washer on one side - the other rubber to dry
- Ideal for cars vans and trucks

Code	Desc.	Characteristics
4460008860	4216	DRYER COMPLETE GLASS

## Sponge with special shape



- Ideal for motorcycles cars and trucks
- Sponge long duration

Code	Desc.	Dimension cm
4460003100	3966	18x12x6,5

## Washing glove in synthetic wool



- Waterproof glove

Code	Desc.
4460006500	3997

## Squeegees dries car



- Practice spatula squeegee to dry faster smooth surfaces and washable as car bodies, trucks, coatings, hard surfaces in general.
- It can be used in virtually every sector of processing type car washes, maintenance generic, cleaning companies.
- Shockproof plastic handle with non-slip soft insert, blade edge of the rubber silicone extremely flexible, scratch insesibile thermal shock and chemical resistance even aggressive.
- Wiping blade width 30 cm, thickness 3 mm.

Code	Desc.
4460008867	4216/S



## Ice scraper



- Spatula ice scraper with handle useful in any situation where there is a need 'to remove ice and frost formed on the windows of vehicles.
- The detergent plastic eliminates the icy layer easily.

Code	Desc.
4460003700	3972

## Toothbrush hydrojet



- Brush in natural fiber.
- Brush to use with extension cords pass water.
- Thread 1/4 gas female.

Code	Desc.	Gas attachment
4460008870	4217	1/4 F

## Extensions pass water



- Extensions metal brush jet.
- Extensions to be connected to the water pipe.
- Different lengths to wash all vehicles.
- One side male thread 1/4 gas - a side barb ø 16 mm.

Code	Desc.	Length
4460008875	4218/90	90 cm
4460008880	4218/180	180 cm

## Kit hydro truck professional



- With wide-angle hydrobrush.
- With protection from scratches and bumps Rubber.
- With telescopic handle 140-240 cm.

Code	Desc.	Measures (mm)
4460008881	4219KIT	140-240

Spare Parts			
Article	Code	Desc.	
Replacement brush	4460008882	4219s	
Telescopic handle parts	4460008883	4219m	

## Valves washing with spear



- With hose
- Indicate for hauliers, on tankers and trucks drains

Code	Desc.	Measures
3450003620	3091-20	1/2" X 20
3450003630	3091-25	3/4" X 25

## Garbage bags



- Polyethylene bags for garbage, ecological and high quality.
- Suitable for all activities, from office to home, on construction sites, in factories and in all places of work, collected and mixed differentiated.
- Supplied in different sizes suitable for bins, bins, baskets of all sizes. Packaged in rolls for greater ease of use and easy storage, with strap for closing, measuring 120 X 150 mm supplied loose in flat boxes.
- For waste disposal heavier (waste of workshops, various types of waste, debris) we recommend the use of size 90 X 120 and 120 X 150.

6

Code	Desc.	Dimension cm	Capacity Lt	Spessore micron	Color
446PU00690	690	120x150	360	0,10	Black
446PU00700	700 - 10	90x120	216	0,08	Black
446PU00701	701 - 20 kg.	90x120	216	0,8	Trasparent
446PU00710	710 - 10	82x110	165	0,045	Black
446PU00715	710 - 20 kg.	82x110	165	0,045	Trasparent
446PU00720	720 - 10	70x110	120	0,035	Black
446PU00730	730 - 10	70x110	120	0,035	Trasparent
446PU00740	740 - 20	50x60	33	0,020	Black
446PU00770	770 - 20	50x60	33	0,020	Trasparent

## Scopa in bambù con manico



- Ideal for outdoor cleaning

Code	Description
446PU00225	225 - Scopa in bambù con manico

## Cleaning products



- Brooms various models.

Code	Description
446PU00220	220-Broom sorghum with a long handle. 140 cm.
446PU00230	230-Broom in nylon fibers without handle
446PU00240	240-Broom synthetic yarn industry without handle
446PU00250	250-Metal handle 120 cm
446PU00260	260-Painted wooden handle 120 cm Ø 23 mm
446PU00270	270-Dustpan to pick up dirt detachable metal

## Professional broom



- Professional broom
- Built with crimped wires PPL.
- Wires stuck the broom with steel foil covered with PVC.
- Extremely robust.
- Screw for handles with standard thread.
- Supplied with handle three pieces of painted metal.
- Simplicity 'mounting of the handle (after connecting between them the three pieces, rotate clockwise to obtain a single piece extremely robust).
- Suitable for all cleaning even the most demanding, in yards or in very rough floors with any kind of dirt.
- Resistant to oils, greases and solvents.
- Used in workshops, carpentry, bodywork, locksmiths and municipal towns, etc.

Code	Desc.	Characteristics
4460000990	3943	Broom complete with wooden handle

## Mop to push



- Mop to push.
- The mop can be fixed to the handle with a screw chipboard 4,5x20 our cod. 2190000250.
- It can be sold together with our handle cod. 446pu00310.

Code	Description
446PU00280	280-Mop 60 cm
446PU00290	290-Mop 80 cm
446PU00300	300-Mop 100 cm
446PU00310	310-handle natural wood 150 cm cone Ø 26 mm

## Squeegees



- Squeegees rubber with metal support.
- It may be fixed to any wooden handle, in particular with our cod. 446pu00350.

Code	Description
446PU00320	320-Squeegees 45 cm
446PU00330	330-Squeegees 55 cm
446PU00340	340-Squeegees 75 cm
446PU00350	350-handle natural wood 150 cm screw diameter 23 mm

## Cart wringing tool professional



- Cart wringing tool professional.
- The gripper can be combined with one of our handles in a choice of cod. 446pu00250 - 446pu00260 - 446pu00350.

Code	Description
446PU00360	360-Cart with two 25-liter buckets and wringing tool

Spare Parts	
Code	Description
446PU00370	370-Strizzatore di ricambio
446PU00380	380-Secchio 25 litri di ricambio
446PU00390	390-Mop in cotone industriale
446PU00400	400-Pinza gigante per mop



## Material for washing floors



- Material for washing floors.
- Scrubbing brush and the mop can be combined with one of your handles in a choice of cod. 446pu00250 - 446pu00260 - 446pu00350.

Code	Description
446PU00410	410-round bucket wringer for 13 lt.
446PU00420	420-mop wringing tool
446PU00430	430-Mop Cotton

## Materiale per lavare i pavimenti



Code	Description
446PU00440	440-Secchio in plastica 12 litri
446PU00450	450-Strofinaccio in cotone

## Port sack cart



- Port sack cart
- Supplied without accessories.
- We recommend the use of the bags 70x110 or 82x110 cm

Code	Description
446PU00470	470- Port sack cart
446PU00480	480-Cover for cart
446PU00490	490-Basket storage for cart
446PU00500	500-Chromed roll holder for cart

## Baskets and dustbins



- Baskets and dustbins
- A - B: we recommend the use of the bags 50x60 cm.
- C: We recommend the use of the bags 70x110 cm.

Code	Description
446PU00510	510-Paper basket, open
446PU00520	520-swinging dustbin 25 liters
446PU00530	530-swinging dustbin 50 liters

## Waste containers



- Waste containers with cap
- D: We recommend the use of the bags 82x110 cm.
- E: We recommend the use of the bags 90x120 cm.

Code	Description	Ext. Dim. Cm <i>width/depth/height</i>
446PU00540	540-Waste container 80 liters	43x40x72
446PU00550	550-Waste container 100 liters	43x40x82
446PU00560	560-Cap for containers 80 and 100 liters	-

## Nail brush



- Brush to remove dirt under nails.
- Practical handle of polypropylene.
- Useful in the working environments, at home and for hobbies.
- Total size mm 26x86x45.
- Nylon bristles 16x73x14h mm.
- Pack with assorted colours.

Code	Description
446PU00850	Nail brush

## Roll of pure cellulose cotton wool - 24g/mq



- Pure cellulose cotton wool.
- 2-ply, white.
- Grammage: 24 g / sqm.
- Does not fray or flake.
- High levels of softness and resistance.
- Recommended for all drying and cleaning operations.
- Length: 150 meters
- Width: 25.5
- Tear length: 30cm

Code	Desc.	N. rips
4460001200	3947	600



- Length: 355 meters
- Width: 35 cm
- Tear length: 30cm

Code	Desc.	N. rips
4460001900	3954	1200

## Roll of blue paper



- Paper pure cellulose 90%
- 3 veils sized blue
- Weight: 20 grams per square meter
- Large capacity absorption
- Indicated in all sectors for cleanings of each gender
- Usable in food industry
- Length 190 m
- Width: 27 cm
- Length 37 cm tear

Code	Desc.	N. rips
4460001100	3946	500

## 500 Roll of ECO 800 paper



- 100% recycled paper.
- 2-ply, white.
- Grammage: 23 gr al mq.
- Widely used in all sectors for cleaning and drying operations.
- Length 185 m
- Width: 22 cm
- Length 25 cm tear

Code	Desc.	N. rips
4460001000	3945	740

## Standing roll holder



- Painted sheet metal.
- Suitable for rolls of paper art. 446 00 01000 3945; 446 00 01100 3946; 446 00 01200 3947; 446 00 01900 3954.

Code	Desc.
4460001300	3948

6

## Wall roll holder



- Predisposed for fixing with inserts.
- Painted sheet metal roll holder suitable for rolls of paper art: 446 00 01000 3945; 446 00 01100 3946 446 00 01200 3947; 446 00 01900 3954.

Code	Desc.
4460001400	3949

## Horizontal roll holder



- Plastic roll holder.
- Predisposed for wall application.
- For use with our rolls art. 446 00 05800 3990

Code	Desc.
4460005500	3987

## Internal extraction roll holder



- Plastic roll holder.
- Predisposed for wall application.
- For use with our rolls art. 446 00 05800 3991; 446 00 06000 3992.

Code	Desc.
4460005700	3989

## Horizontal hand towels



- Pure cellulose roll.
- 2-ply.
- Grammage: 20 gr/mq
- Excellent absorbency.
- For use with roll holder art. 446 00 05500-3987.

Code	Desc.	Formato h mm - L m
4460005800	3990	215 - 60

## Internal extraction hand towels



- Pure cellulose roll.
- 1-ply, smooth
- Grammage: 27 gr/mq
- Excellent absorbency.
- For use with internal extraction roll holder art.446 00 05700-3989.
- N.B.: remove cardboard centre before use.

Code	Desc.	Formato h mm - L m	Ø est.
4460005900	3991	200 - 110	13 cm
4460006000	3992	215 - 290	20 cm

## Salviette piegate a C



- Formato 21,5x19 cm
- Ideale per asciugatura mani nei bagni

Code	Desc.	Formato h mm - L m
4460006110	3993	21,5x19



### Distributore per salviette



- Idoneo per salviette piegate a C
- Colore bianco in ABS
- capacità 600 salviette
- Dimensioni 27,6x13x36,5 cm

Code	Desc.
4460006130	3993/2

### Lavatory paper in rolls



- Pure cellulose cotton wool.
- 2-ply.
- Roll of 200 sheets.

Code	Desc.
4460000995	3944

### Pre-filter petrol transparent



- Prefilters petrol transparent double inlet pipe Ø 6 to 8 mm

Code	Desc.
4530000100	1960

### Pre-filter petrol transparent

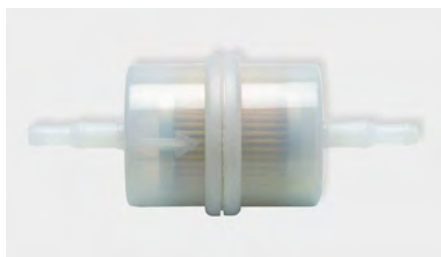

- Prefilters petrol transparent double inlet pipe Ø 6 to 8 mm

Code	Desc.
4530000200	1961

### Prefilter transparent



- For petrol and wipers
- For motorcycles up to 350 cc.
- Entrance pipe Ø 5 mm

Code	Desc.
4530000300	1962

### Prefilter for diesel Mercedes



- Double inlet pipe ø 6 and 8mm

Code	Desc.
4530000400	1963

### Prefilter for diesel Mercedes



- Entrance pipe diameter 8mm

Code	Desc.
4530000500	1964

### Prefilter for diesel trucks and marine engines



- Double inlet pipe ø 6 and 8mm

Code	Desc.
4530001000	1969

## Prefilter for diesel vehicles



Code	Desc.	Ø tubo
4530000600	1965	6-8
4530000610	1965/10	10
4530000613	1965/13	13

## 6 Fuel filter with quick connectors



- Structure in transparent plastic with internal filter.
- Quick Couplers steel at the ends'.
- Appicazione on vehicles with power plant in Rilsan tube.
- Speed 'and simplicity' in the implementation without additional tools.
- Ideal for vans and trucks of the latest generation.

Code	Desc.	Rapid Conn.	Dim. Ø x len. mm - RAC.
4530001200	1970	8 mm	42x122-8mm
4530001300	1980	10 mm	42x122-10mm
4530001400	1990	12 mm	42x122-12mm

## Drier universal



- Filter dryer screwable for braking systems industrial vehicles.
- The dryer means safe operation of the braking system, since only the absence of moisture in the air can avoid the corrosion and freezing of the braking pressure. It also filters particles of dirt, oil and residue oil carbonization.



DIMENSIONI FILTRO UNIVERSALE mm					
Cod.	A	B	C	G	H
08100	136	98	110	M39X1.5	165

Code	Description
4890008100	P781466 Donaldson Filter drier

## Rubber hose for radiators



Code	Desc. Ø int. x Ø ext.
373RA00100	18x24
373RA00200	20x26
373RA00300	22x28
373RA00400	25x32
373RA00500	28x36
373RA00600	30x38
373RA00700	32x40
373RA00800	35x43
373RA00900	38x47
373RA01000	40x49
373RA01100	42x51
373RA01200	45x54
373RA01300	50x60
373RA01400	55x65
373RA01500	60x70
373RA01550	65x76
373RA01600	70x81
373RA01650	76x86
373RA01700	80x92
373RA01800	90x102

- APPLICATIONS
- Flexible connection in engine cooling circuits and heating cockpit cars.
- Supply hot water mixed with antifreeze.
- STRUCTURE
- Rubber hose with black smooth substrate.
- Heat resistant.
- Textile yarn reinforcement and cover cloth impression.
- Black Colour.
- Operating temperature -40 ° C + 100 ° C
- operating pressure of 3 bar
- Supplied in 1 m lengths linear.

## Silicone tube radiator



Code	Desc. Ø int.
373RS00100	16
373RS00110	19
373RS00115	20
373RS00120	22
373RS00130	25
373RS00140	28
373RS00160	30
373RS00190	35
373RS00200	38
373RS00210	40
373RS00220	42
373RS00230	45
373RS00240	48
373RS00250	50
373RS00270	55
373RS00290	60
373RS00300	65
373RS00320	75
373RS00330	80
373RS00335	85
373RS00350	100

- APPLICATIONS
- Silicone tubing for connection between engine and radiator bus and industrial vehicles.
- Resistant to the passage of fluid with antifreeze.
- Indispensable when you reach high temperatures.
- STRUCTURE
- Silicone tube with smooth substrate.
- Reinforced with 3 textile insertions.
- Smooth outer fabric finished.
- Weather-resistant and heat.
- Operating temperature -40 ° C + 200 ° C.
- Operating pressure of 3 bar.
- Supplied in lengths from 1 m linear.

## Silicone tube for heating



TEMPERATURA DI ESERCIZIO -40°C +200°C  
PRESSIONE DI ESERCIZIO 3 BAR



- APPLICATIONS
- Silicone tube used for the connection from the radiator inside the cabin for heating. Used on buses and industrial vehicles.
- Resists the passage of anti-freeze.
- STRUCTURE
- Silicone tube with smooth substrate.
- Reinforced with 3 textile insertions.
- Smooth outer fabric finished.
- Weather-resistant and heat.
- Pressure: 3 bar.

6

Code	Desc. Ø int.
373RI00210	8
373RI00300	10
373RI00400	13
373RI00500	16
373RI00650	18/1
373RI00710	19
373RI00800	25

## Pipe passing hot water



TEMPERATURA DI ESERCIZIO -40°C +120°C  
PRESSIONE DI ESERCIZIO 10 BAR



- Applications;
- Pipe passage hot water up to + 120 ° C.
- Used for connecting circuits of cooling and heating in motor vehicles, commercial and industrial vehicles.
- Used for delivery of water mixed with steam.
- Structure:
- Rubber hose with black smooth substrate.
- Heat resistant.
- Reinforcements and cover with fabric impression.
- Fluid resistant antifreeze.

Code	Desc. Ø int. x Ø ext.
373AQ01100	10x20
373AQ01200	12x22
373AQ01300	15x25
373AQ01400	18x28
373AQ01500	20x30
373AQ01502	22x28



## Corrugated tube radiators



TEMPERATURA DI ESERCIZIO -40°C +120°C  
PRESSIONE DI ESERCIZIO 4 BAR



- APPLICATIONS
- Pipe radiator cars and trucks.
- Supply hot water mixed with antifreeze.
- Excellent flexibility for the assembly in the engine compartments.
- Thanks to the metal spiral inside can get tight radii of curvature.
- STRUCTURE
- Rubber hose with smooth black heat-resistant substrate.
- Textile yarn reinforcement.
- Steel wire helix.
- Smooth exterior with helical groove.
- Black Colour.
- Operating temperature -40 ° C + 120 ° C. Operating pressure of 4 bar.
- Resistant to abrasion and weathering.
- Supplied in coils.

Code	Desc. Ø int. x Ø ext.
373RC00200	20x28
373RC00220	22x30
373RC00300	28x36
373RC00500	32x40
373RC00600	35x43
373RC00700	38x46
373RC00800	40x50
373RC00900	51x61

## Tubi in gomma passaggio carburante ecologico

### APPLICAZIONI

Mandata di carburanti , gasolio, benzina senza piombo, eco diesel e lubrificanti in genere. Utilizzato sui motori a combustione interna delle autovetture, veicoli industriali e movimento terra.



### STRUTTURA

- COPERTURA: GOMMA NERA (NBR/CR) RESISTENTE AI LUBRIFICANTI, AI CARBURANTI, ALL'ABRASIONE, AGLI AGENTI ATMOSFERICI E ALLE ALTE TEMPERATURE.
- SUPERFICIE: LISCIA SOTTOPIOMBO.
- SOTTOSTRATO: LISCIO IN GOMMA NBR RESISTENTE AI CARBURANTI CON CONTENUTO AROMATICO FINO AL 40 % E ALLE BENZINE SENZA PIOMBO.
- RINFORZI: INSERZIONI TESSILI AD ALTA RESISTENZA.
- TEMPERATURA D'ESERCIZIO: -20°C + 100°C.

## Plugs injectors



- NBR rubber compound black
- Resistant to fuels and lubricants

Code	Description
2930004000	4000- cap injector univ.

## Tube bundle



Code	Desc. Ø int. x Ø ext.
373TE00030	4x9
373TE00060	5x10
373TE00090	6x13
373TE00120	7x13
373TE00150	7,5x14
373TE00160	8x15
373TE00180	10x16
373TE00210	12x19
373TE00230	15x23
373TE00240	19x27
373TE00290	25x35

## Hose Reel



Code	Desc. Ø int. x Ø ext.	Length mt
373BO02400	4x9	15
373BO02500	5x10	15
373BO02600	6x13	15
373BO02700	7x13	15
373BO02800	7,5x14	15
373BO02850	8x15	10
373BO02900	10x16	10

## Fuel Hose canvas outer



- Lining: 100% cotton, green-black.
- According to DIN 73379 B.
- Tube: Black NBR rubber compound resistant to unleaded fuels.
- Pipe indicated for recovery injectors.
- Not suitable for turbo cars or direct injection

Code	Desc. Ø int. x Ø ext.	Length m	Type
373OT00050	3x7	-	Hank
373BO00100	3x7	25	Coil

## All rubber hose fuel passage



- NBR rubber compound black
- Resistant to fuels and lubricants
- Resistant to unleaded fuel
- Operating temperature: -20 ° C + 80 ° C
- Suitable for the recovery injectors.
- Not suitable for turbo cars or direct injection

Code	Desc. Ø int. x Ø ext.	Length m	Type
373GP00100	3x7	-	Hank
373BO01100	3x7	25	Coil

## Fuel Hose ecological canvas internal diameter 3.2 x 8.2



- Rubber compound with canvas-reinforced inner soul.
- Resistant to fuels and lubricants.
- Suitable for the recovery primers for latest generation cars.
- Eurocarboecologic ISO 1307.
- Maximum operating pressure of 10 bar.
- Diameter of the pipe 3,2x8,2.
- Provided that in both the hank reel.

Code	Description
373TE00020	3,2x8,2 -Pipe canvas int. ISO 1307 skein
373BO01160	3.2 x 8.2-canvas hose reel 25mt in.ISO 1307

## Hose depressors



- Tube air passage for depression
- Also suitable for cars powered by gas.
- NBR rubber hose
- Black Colour
- Operating temperature: -20 ° C + 80 ° C
- Provided Reel

Code	Desc. Ø int. x Ø ext.	Length m
373BO01150	4x8,8	20

## Pipe water flow to windscreen



- Black: passing water washer.

Code	Desc. Ø int. x Ø ext.	Color	Press. explosion bar	Temp. Eserc. °C	Type
3730C00250	4x7	Black	40	-40 +70	Hank

## Fuel tube passage polyurethane



- Pipe for mopeds and motorcycles
- Step blends and unleaded petrol
- For flow and return
- Suitable for lubricants
- Provided Reel
- Color: transparent

Code	Desc. <i>Ø int. x Ø ext.</i>	Length <i>m</i>
373BO03600	5x10	20
373BO03700	6x11	20
373BO03800	7x11	20

## Fuel tube passage in special compound



- Pipe for mopeds and motorcycles
- Step blends and unleaded petrol
- Suitable for lubricants
- Provided Reel
- Black Colour

Code	Desc. <i>Ø int. x Ø ext.</i>	Length <i>m</i>	Application
373BO03900	4x9	20	DELIVERY + RETURN
373BO04000	5x7	20	ONLY RETURN

## Pipe oil passage for mixer



- Pipe for mopeds
- Oil passage
- Provided Reel
- Black Colour

Code	Desc. <i>Ø int. x Ø ext.</i>	Length <i>m</i>
373BO04100	2x5	30



## Exhibitor hose reels



- The Meccanocar created for the tube passage fuel a compact display that attaches to the wall or on the head of a shelf. Even here the slogan Meccanocar "EARNINGS TIME IF EVERYTHING 'in its place'" is appropriate, because it avoids waste and loss of time in search of models.

Code	Description	Ingombro mm
373B100300	1902 - complete	600x880x160
373B100200	1900 - empty	600x880x160

CONTENUTO			
1 BOBINA	m 25	COD. 373 BO 01100-3x7	T. RECUPERO INIETTORI
1 BOBINA	m 20	COD. 373 BO 01150-4x8,8	T. PER DEPRESSORI
1 BOBINA	m 15	COD. 373 BO 02500-5x10	T. PASSAGGIO CARBUR.
1 BOBINA	m 15	COD. 373 BO 02600-6x13	T. PASSAGGIO CARBUR.
1 BOBINA	m 15	COD. 373 BO 02800-7,5x14	T. PASSAGGIO CARBUR.
1 BOBINA	m 10	COD. 373 BO 02900-10x16	T. PASSAGGIO CARBUR.
1 ESPSITORE		COD. 373 B1 00200-1901	ESPOSITORE

## Coil tube empty



Code	Desc.	Ø x Larghezza
373B100100	1900	20x15,5 cm

6



## Lifting slings "Meccanocar"



**A NORME CEN**  
ALLESTIMENTO SECONDO  
LA NORMA PR EN 1492 E  
SECONDO LA NORMATIVA  
COMUNITARIA SULLE  
MACCHINE 89/392 PARTE 4.1

CERTIFICATO DI CONFORMITA'

**OGNI BRACA E' CORREDATA DI CERTIFICATO  
DI CONFORMITA' ALLE NORME CEN**

\* NOTA BENE: TRANNE IL MODELLO  
S 1000 IN STRATO SEMPLICE, LE  
BRACHE PIATTE SONO IN DOPPIO  
S T R A T O



TIPO	CARICO DI LAVORO					
	LARGH. mm	TIRO DIRETTO Kg	DOPPIO Kg	A CAPPIO Kg	DOPPIO β ≤ 45° - Kg	DOPPIO β ≤ 60° - Kg
S 1000*	50	1.000	2.000	800	1.400	1.000
S 2000	60	2.000	4.000	1.600	2.800	2.000
S 3000	90	3.000	6.000	2.400	4.200	3.000

- Lifting tapes double-layer polyester 100% first choice.
- Safety factor 7/1 - matching colors / flow to CEN.
- Slots tapered and coated in plastic, highly resistant to abrasion.
- Elongation max. in workload <5%.
- Security labels and certificate of conformity 'Meccanocar'.
- Indication of the "application" from the user.

Code	Desc.	Length m	Width mm	Color
5070003880	1 - S1000 - 1	1	50	Violet
5070000100	1 - S1000 - 2	2	50	Violet
5070000200	1 - S1000 - 3	3	50	Violet
5070000300	1 - S1000 - 4	4	50	Violet
5070000350	1 - S1000 - 6	6	50	Violet
5070000390	2 - S2000 - 1	1	60	Green
5070000400	2 - S2000 - 2	2	60	Green
5070000500	2 - S2000 - 3	3	60	Green
5070000600	2 - S2000 - 4	4	60	Green
5070000650	2 - S2000 - 6	6	60	Green
5070000690	2 - S2000 - 9	9	60	Green
5070000695	3 - S3000 - 1	1	90	Yellow
5070000700	3 - S3000 - 2	2	90	Yellow
5070000800	3 - S3000 - 3	3	90	Yellow
5070000900	3 - S3000 - 4	4	90	Yellow
5070000950	3 - S3000 - 6	6	90	Yellow
5070000980	3 - S3000 - 9	9	90	Yellow

## Protective housings PVC



- Sheath to be inserted in the slings to protect against rough and abrasive loads.

Code	Desc.	Length m	For slings width Mm
5070001000	6 - PVC - 75	1	56-60
5070001100	7 - PVC - 100	1	75-90

## Roundslings round

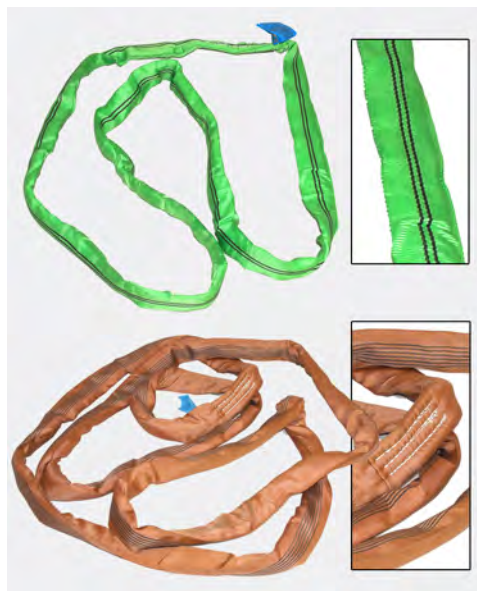

- Polyester round slings.
- Polyester thread looped with tubular sheath that protects the integrity.
- A certificate of conformity with standards EN1492-2 sewn on each piece
- Comply with the Machinery Directive EC 89 392 EEC IIA-Technical standard EN1492 Part 2.
- Safety factor 7/1.
- Color CEN.

Code	Desc.	Color	Payload kg
5070001101	1-S2000A-1M	Green	2000
5070001102	2-S2000A-2M	Green	2000
5070001103	3-S2000A-3M	Green	2000
5070001104	4-S2000A-4M	Green	2000
5070001110	5-S2000A-5M	Green	2000
5070001112	6-S2000A-6M	Green	2000
5070001114	8-S2000A-8M	Green	2000
5070001160	6-S6000A-6M	Brown	6000
5070001180	8-S6000A-8M	Brown	6000

# Ancoraggi per veicoli industriali "Meccanocar"

- TENSIONATORE IN ACCIAIO ZINCATO.
- NASTRO IN POLIESTERE 50-75 mm.
- CON OTTIMA RESISTENZA ALL'USURA E ALL'ABRASIONE
- IDEALE PER FISSAGGIO CARICHI SU MEZZI PESANTI E FURGONI.
- SISTEMA COMPLETO mt 9,00 E 9,50.
- PARTE FISSA CON TENSIONATORE m 0,50
- PARTE LUNGA m 8,50 E 9,00

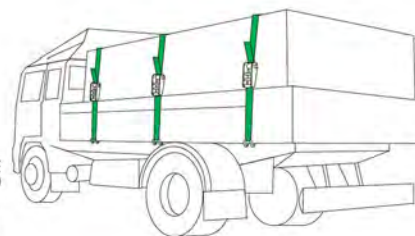
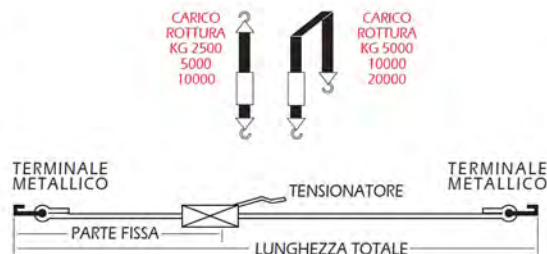

## Hook side



Code	Desc.	Width mm	Length m	Breaking load	Workload Kg
5070001200	8	50	9,0	2500/5000 Kg	1600/3200
5070001202	8/2	50	9	4000/8000 Kg	2000/4000
5070003700	60	50	9,5	5000/10000 Kg	2500/5000

## Hook the short side



- Tape width 50-75.
- Galvanized steel tensioner.
- EC certificate.

Code	Desc.	Length m	Breaking load	Workload Kg
5070001600	12	0,5	2500/5000 Kg	1600/3200
5070003740	64	0,5	5000/10000 Kg	2500/5000

## Hook the long side



- Long pieces.
- Tape width 50-75.
- EC certificate.

Code	Desc.	Width mm	Length m	Breaking load	Workload Kg
5070002000	16	50	8,5	2500/5000 Kg	1600/3200
5070002050	16/1	50	12	2500/5000 Kg	1600/3200
5070003780	68	50	9	5000/10000 Kg	2500/5000

## Hook double hook



Code	Desc.	Width mm	Length m	Breaking load	Workload Kg
5070001300	9	50	9,0	2500/5000 Kg	1600/3200
5070001302	9/2	50	9	4000/8000 Kg	2000/4000
5070003710	61	50	9,5	5000/10000 Kg	2500/5000
5070003820	72	75	9,5	10000/20000 Kg	4500/9000

## Hook double hook part short

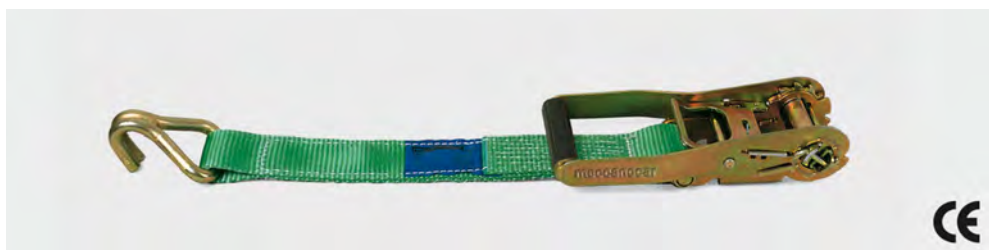

- Fixed part with tensioner.
- Tape width 50-75.
- Galvanized steel tensioner.
- EC certificate.

Code	Desc.	Length m	Breaking load	Workload Kg
5070001700	13	0,5	2500/5000 Kg	1600/3200
5070003750	65	0,5	5000/10000 Kg	2500/5000
5070003840	74	0,5	10000/20000 Kg	4500/9000

## Hook double hook the long end



- Long pieces.
- Tape width 50-75.
- EC certificate.

Code	Desc.	Width mm	Length m	Breaking load	Workload Kg
5070002100	17	50	8,5	2500/5000 Kg	1600/3200
5070002150	17/1	50	12	2500/5000 Kg	1600/3200
5070003790	69	50	9	5000/10000 Kg	2500/5000
5070003860	76	75	9	10000/20000 Kg	4500/9000

## Triangular hook



Code	Desc.	Width mm	Length m	Breaking load	Workload Kg
5070001400	10	50	9,0	2500/5000 Kg	1600/3200
5070003720	62	50	9,5	5000/10000 Kg	2500/5000
5070003830	73	75	9,5	10000/20000 Kg	4500/9000



## Triangular hook part short



- Fixed part with tensioner.
- Tape width 50-75.
- Galvanized steel tensioner.
- EC certificate.

Code	Desc.	Length m	Breaking load	Workload Kg
5070001800	14	0,5	2500/5000 Kg	1600/3200
5070003760	66	0,5	5000/10000 Kg	2500/5000
5070003850	75	0,5	10000/20000 Kg	4500/9000

## Triangular hook the long end



- Long pieces.
- Tape width 50-75.
- EC certificate.

Code	Desc.	Width mm	Length m	Breaking load	Workload Kg
5070002200	18	50	8,5	2500/5000 Kg	1600/3200
5070003800	70	50	9	5000/10000 Kg	2500/5000
5070003870	77	75	9	10000/20000 Kg	4500/9000

## Eyelet terminal



Code	Desc.	Width mm	Length m	Breaking load	Workload Kg
5070001500	11	50	9,0	2500/5000 Kg	1600/3200
5070003730	63	50	9,5	5000/10000 Kg	2500/5000

## Eyelet terminal part short



- Fixed part with tensioner.
- Tape width 50-75.
- Galvanized steel tensioner.
- EC certificate.

Code	Desc.	Length m	Breaking load	Workload Kg
5070001900	15	0,5	2500/5000 Kg	1600/3200
5070003770	67	0,5	5000/10000 Kg	2500/5000

6

## The long terminal eyelet



Code	Desc.	Width mm	Length m	Breaking load	Workload Kg
5070002300	19	50	8,5	2500/5000 Kg	1600/3200
5070002350	19/1	50	12	2500/5000 Kg	1600/3200
5070003816	71/16	50	16	4000/8000 Kg	2000/4000
5070003810	71	50	9	5000/10000 Kg	2500/5000
5070003815	71/21	50	21	5000/10000 Kg	2500/5000

## Anchorage for panels "Meccanocar"

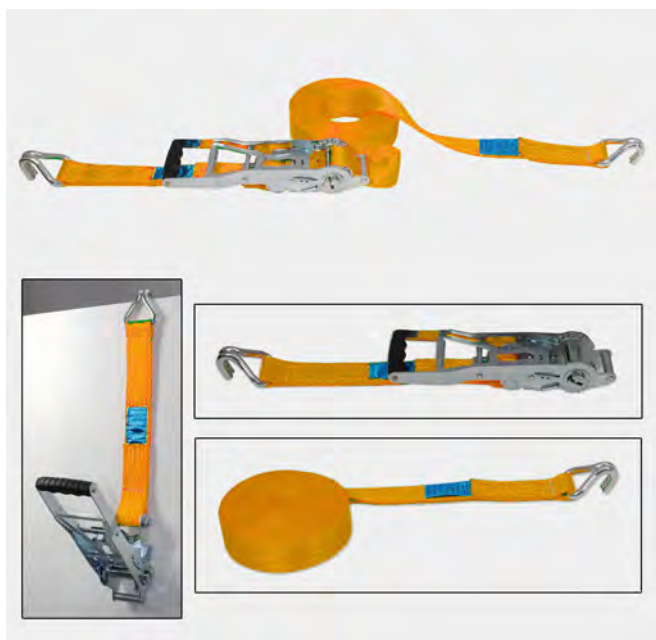

- Anchorage system Ratcheting panels.
- Tensioner prolonged galvanized steel.
- Polyester tape 50mm.
- Excellent resistance to wear and abrasion.
- With hook double hook.
- Tensioning mechanism from the top down.
- Complete system mt 9:50.
- Fixed part with tensioner M 0.50.
- Part 9m long.
- EC certificate.
- WARNING! The tables are the tensile strengths but remember that to choose the most appropriate anchoring system we must always rely on the workload.

Code	Desc.	Width mm	Length m	Breaking load	Workload Kg	Model
5070004000	80	50	9,5	5000/10000 Kg	2500/5000	complete anchoring
5070004010	85	50	0,5	5000/10000 Kg	2500/5000	Fixed part with tensioner
5070004020	90	50	9,0	5000/10000 Kg	2500/5000	Long part

## Ancoraggio completo gancio sponda



- Ancoraggio completo per pannelli Meccanocar gancio sponda

Code	Desc.	Width mm	Length m	Breaking load	Workload Kg
5070004022	92	50	9,5	5000/10000 kg	2500/5000



## Technical tape polyethylene



- Tape roll used for bindings to lose.
- Tape width 50mm.
- Tensile strength 5000kg.
- Tape thickness 2.1mm.

Code	Desc.	Color	Length m
5070004040	96-H50x5000kg	Light blue	100

## Protection angular PVC



- Protection panel speakers, etc..
- Ideal to avoid damaging sharp edges and at the same time protects the belt anchor.
- Protection for tape width 50 mm.

Code	Desc.	Color
5070002400	20	White
5070002428	28	Brack



## Ancoraggi per trasporto veicoli

- BISARCHE PER IL TRASPORTO VEICOLI
- NASTRO IN POLIESTERE 100%
- FISSAGGIO CON GANCI AD UNCINO

## Car transporter 3 points



Code	Desc.	Width mm	Length m	Portata	Breaking load
5070002500	20	35	2,20	1200 DAN	3300 Kg
5070002510	21/50	50	2,5	1600 DAN	5000

## Car transporter 2 points



Code	Desc.	Width mm	Length m	Portata	Breaking load
5070002600	22	35	2	1200 DAN	3000 Kg

## Anchoring medium "Meccanocar"

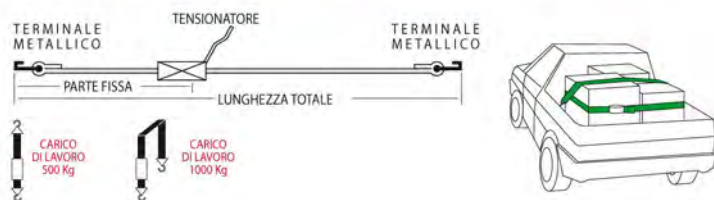

- Anchoring indicated where it requires a high tensile strength with a small footprint.
- Tape width 35 mm.
- 6 m length tape.
- Two hooks.
- Ideal for securing loads on trucks and vehicles.
- Complies with European standard EN 12195-2.

Code	Desc.	Width mm	Length m
5070002700	23	35	6

## Anchoring light "Meccanocar"



- Ideal anchor for securing loads on vehicles-carts etc.
- Tape width 25 mm.
- Tape length 4 m.
- Two hooks.
- Complies with European standard EN 12195-2.

Code	Desc.	Width mm	Length m
5070002800	24	25	4

## Anchoring light "Meccanocar"



- Various applications, easy to use
- Tape width 25 mm
- Tape length 4 m
- Complies with European standard EN 12195-2
- EC certification

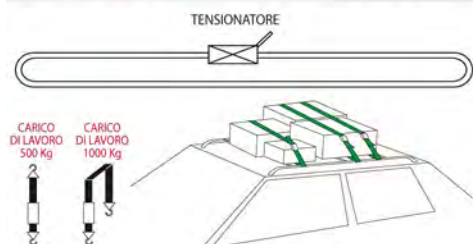

Code	Desc.	Width mm	Length m
5070002900	25	25	4

## Anchoring for motorcycles



- Anchoring specific for the attachment of motorcycles and motorcycles on trolleys.
- Hooks plasticized externally to avoid scratching any details.
- Tape width 25 mm.
- Overall length 1.60 m breaking load 1000 kg.

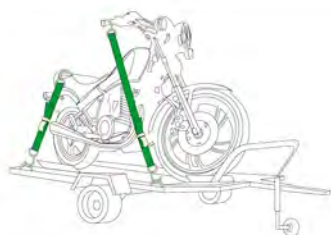

Code	Desc.
5070003000	26

## Profile load stops

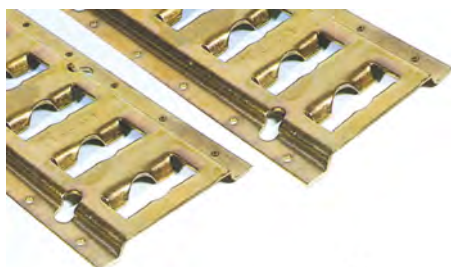

- Horizontal mounting.
- Shaped soles.
- Usable on all trucks vans.
- Suitable for use in load retaining straps with hooks 1826 (not included).
- Galvanized steel.
- Application by screws (not included).

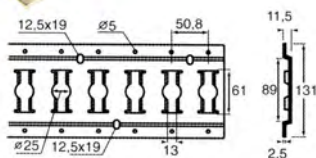

Code	Desc.	Tape length	Material	Weight Kg.
4460010200	3009	3048 mm	GALVANIZED STEEL	7

## Ancoraggio per profilo fermacarico

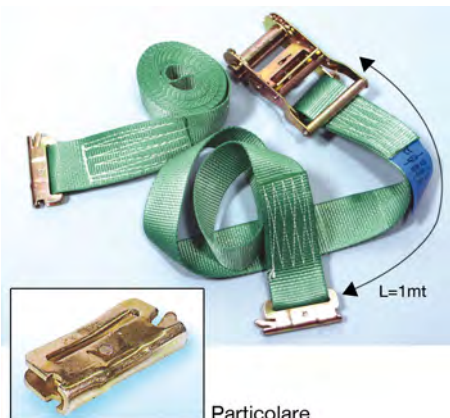

- Kit with hook for load retaining profile 3009.
- Suitable for any type of load.

Code	Desc.	Width tape mm	Tape length	Breaking load
4460010250	1826	50	3+1 m	2600 Kg
4460010251	1826R	50	3+1 m	5000 Kg

## Cargo Keeper spring

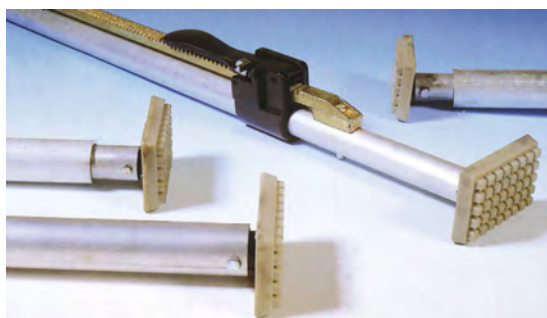

- Cargo Keeper is a special pole load stops that for its implementation does not require any type of rail.
- It equipped with two large rubber pads that ensure a perfect grip on the floor that is on the ceiling of the vehicle-trailer.
- Article made of aluminum, so with a very low weight (4kg).
- Practical tensioning system with spring that ensures a gradual thrust in the application phase and of movement of the medium on which it is mounted.

Code	Desc.	Length mm	Diametro tubo mm	Material	Weight Kg.
4460010150	1867WS	2240-2630	38	ALUMINIUM	4

## “Cargo Stop” barre fermacarico

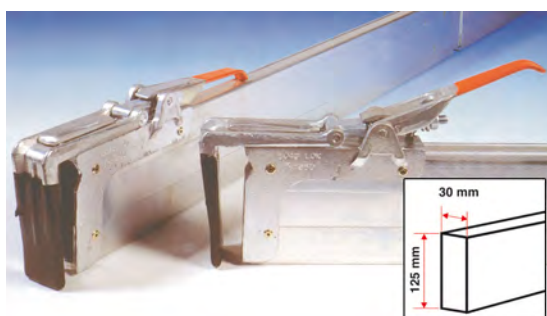

- "Cargo Stop" bar load stops
- Cargo stop is a Load retaining bar extremely useful for clamping any type of load on the means tilts.
- Possibility of locking the load of any means.
- It hikes standards ranging from 2400 mm to 2700 mm.
- It equipped with two clamps to stremità cast iron covered with PVC as to ensure maximum and perfect grip on the aluminum slats of the ribs.

Code	Desc.	Dimensions mm	Material	Min. length mm	Length max. mm	Weight
4460010110	1850	125x30	ALLUMINIUM	2400	2700	9

## Clamp cast iron parts



- Cast iron material.
- PVC protection.
- Slip and maximum grip on the slats of the ribs.
- Parts for our article 10110 00 446 Load retaining bar.

Code	Desc.	Material	Weight Kg.
4460010115	1850/1	CAST IRON	2,5



## “Palo Fermacarico” sezione quadrata con tamponi in gomma.



- The new "Load stops Stake" has been designed for the tightness of the goods contained in vans and trucks in general. It is equipped with a spring at the base to absorb an eventual excessive clamping force exerted on the closing handle. This prevents any damage to the walls of the medium and thanks to the two rubber pads white prevents staining of the walls themselves. They are recommended for holding loads on pallets or other supports, in that the conical structure of the pad avoids jammed under the pallet or the support itself.
- Material galvanized steel white.
- Length mm. From 1850 to 2850.
- Material thickness mm. 1.8.
- White galvanized finish.
- Section of the tubular mm. 35x35.
- Weight. 6.5.

Code	Description
4460010170	1900-POLE LUGGAGE SECTION / SQUARE
4460010172	RUBBER REPLACEMENT

## Barra fermacarico per centinati



- Tipo leggero
- Sezione barra 40x40
- Escursione mm 1920-2700

Code	Desc.	Opening mm
4460010116	1856	1920-2700

## Barra portante per doppi piani



- Costruzione in alluminio/acciaio
- Escursione mm 2330-2600

Code	Desc.	Opening mm
4460010117	1857	2330-2600



### Barre fermacarico in acciaio zincato



- Indicato per il serraggio della merce contenuta nei furgoni isometrici
- Sistema di foratura ad asola
- Con tamponi in gomma bianca per non macchiare le pareti
- Originale Pondi Rosa

Code	Desc.	Opening mm
4460010174	1904	1820-2820

Spare Parts	
Code	Description
4460010175	1905 - Molla di ricambio in acciaio

6

### Barre fermacarico in acciaio zincato



- Con perno d.24 mm da inserire nei profili del furgone da un lato
- Con tampone in gomma bianca per non macchiare le pareti
- Originale Pondi Rosa

Code	Desc.	Opening mm
4460010176	1906	2350-2820

Spare Parts	
Code	Description
4460010175	1905 - Molla di ricambio in acciaio

## Genoan chain



- Chromated steel.
- Intended Use: electrical, carpentry.
- Suitable for fastening elements and lighting fixtures and carpentry.
- Provided on plastic drum.
- DIN 5685/A

Code	Desc.	d mm	Length m	Misura francese	Misura bobina	Breaking load	Color
1550010871	1,5	1,5	100	10	20x20x10	79	BIANCO
1550010872	2,3	2,3	80	15	20x20x20	196	BIANCO
1550010873	2,7	2,7	50	17	20x20x15	275	BIANCO
1550010874	3,4	3,4	45	18	20x20x20	373	BIANCO
1550010875	4	4	25	19	20x20x15	490	BIANCO
1550010876	4,3	4,3	35	20	20x20x20	588	BIANCO
1550010877	5	5	35	21	20x20x30	735	BIANCO

## Pendants chain grade 80 with hooks shorteners



- Pendants chain grade 80 with 2 and 04 arms. Pendants are assembled with: bell, connecting links, clevis hooks, hooks shorteners, all steel grade 80.
- Use sectors: heavy carpentry, construction, building.
- CE compliant - EN 818 with safety factor of 4: 1. scope of work calculated with a central angle of 90°.
- Steel g / 80 galvanized and painted.
- Temperature range: from -40°C to +200°C.
- Nameplate.
- Packed in practical and robust plastic pails.

6

Code	Desc.	Payload 0-45°	Length m	Chain diameter (mm)	Characteristics
5070003010	27/1	2240	1	7	PENDANT ARMS 2 (PHOTO A)
5070003020	27/2	2240	2	7	PENDANT ARMS 2 (PHOTO A)
5070003030	27/3	2240	3	7	PENDANT ARMS 2 (PHOTO A)
5070003040	27/4	2240	4	7	PENDANT ARMS 2 (PHOTO A)
5070003050	28/1	4500	1	10	PENDANT ARMS 2 (PHOTO A)
5070003060	28/2	4500	2	10	PENDANT ARMS 2 (PHOTO A)
5070003070	28/3	4500	3	10	PENDANT ARMS 2 (PHOTO A)
5070003080	28/4	4500	4	10	PENDANT ARMS 2 (PHOTO A)
5070003090	29/1	3360	1	7	PENDANT ARMS 4 (PHOTO B)
5070003100	29/2	3360	2	7	PENDANT ARMS 4 (PHOTO B)
5070003110	29/3	3360	3	7	PENDANT ARMS 4 (PHOTO B)
5070003120	29/4	3360	4	7	PENDANT ARMS 4 (PHOTO B)
5070003130	30/1	6700	1	10	PENDANT ARMS 4 (PHOTO B)
5070003140	30/2	6700	2	10	PENDANT ARMS 4 (PHOTO B)
5070003150	30/3	6700	3	10	PENDANT ARMS 4 (PHOTO B)
5070003160	30/4	6700	4	10	PENDANT ARMS 4 (PHOTO B)

## Chain stainless steel grade 80

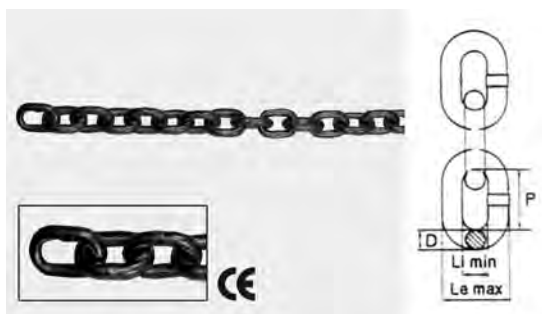

- Chain stainless steel grade 80.
- CEEN818 compliant with safety factor 4: 1. scope of work calculated with a central angle of 90°.
- Steel G / 80 galvanized black.
- Temperature range: from -40 ° C to +200 ° C.
- Supplied in a reel 10 mt.

Code	Desc.	Payload Kg (4:1)	DN (mm)	P mm	LI min. (mm)	LE max (mm)
5070003170	31/7	1500	7	21	9.1	25.9
5070003180	31/10	3150	10	30	13	37

## Connecting link chain grade 80

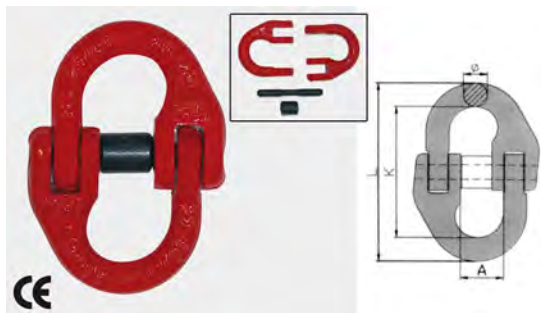

- Connecting link chain grade 80.
- Red.
- Used to mount on the chain hooks and hooks with safety shorteners.
- Complies with CE-EN818, with safety factor 4: 1.
- Steel G / 80.

Code	Desc.	DN (mm)	Payload Kg (4:1)	A mm	L mm	K mm	Ø mm
5070003190	32/7	7/8	2000	20.5	75	57	8.5
5070003200	32/10	10	3200	28	89	68	10.8

## Shortening hook grade 80



- Shortening hook grade 80. Red.
- To be mounted on the connecting link.
- complies with CE-EN818, with safety factor 4: 1.
- Steel G / 80.

Code	Desc.	DN (mm)	Payload Kg (4:1)	E mm	Ø mm	H mm	R (mm)
5070003220	33/7	7/8	2000	10.8	17	24	54
5070003230	33/10	10	3200	13	20	29	79

## Little bell oval grade 80 for pendants in chain



- Little bell oval grade 80 for pendants chains, 2 legs. Red.
- Complies with CE-EN818, with safety factor 4: 1.
- Steel G / 80.

Code	Desc.	Chain 2 arms DN	Payload Kg (4:1)	A mm	B mm	Ø mm
5070003250	34/7	7	2000	110	60	16
5070003260	34/10	10	5300	160	90	22

## Little bell triple degree 80 pendants chain with 4 arms

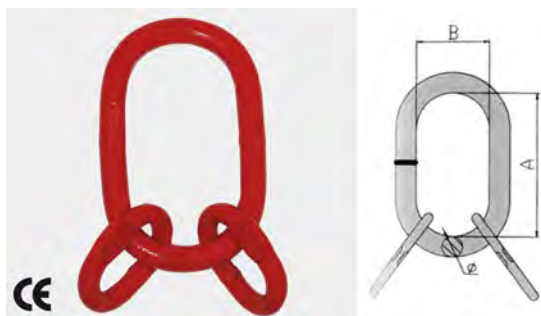

- Little bell triple degree 80 pendants chain with 4 arms. Red.
- Complies with CE-EN818, with safety factor 4: 1.
- Steel G / 80.

Code	Desc.	DN (mm)	Payload Kg (4:1)	A mm	B mm	Ø mm
5070003280	35/7	6/7	3150	135	75	18
5070003290	35/10	10	8000	180	100	26

6

### Clevis hook grade 80

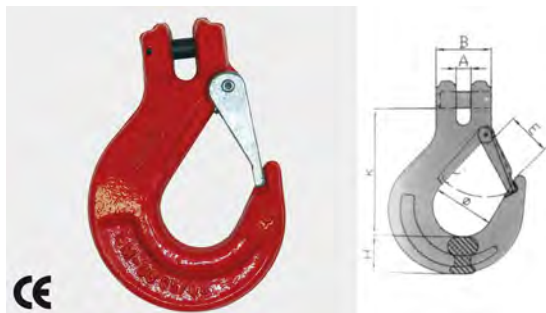

- Clevis hook grade 80 for pendants chain. Red.
- Hook clevis is mounted directly on the chain.
- Complies with EC-EN818, with safety factor 4: 1.
- Steel G / 80.

Code	Desc.	DN (mm)	Payload Kg (4:1)	A mm	B mm	Ø mm	H mm	K mm	E mm
5070003310	36/7	7/8	2000	9.5	37	37	32.5	85	25
5070003320	36/10	10	3200	13	49	46	35	104	31.5

### Gancio clevis self-locking grado 80

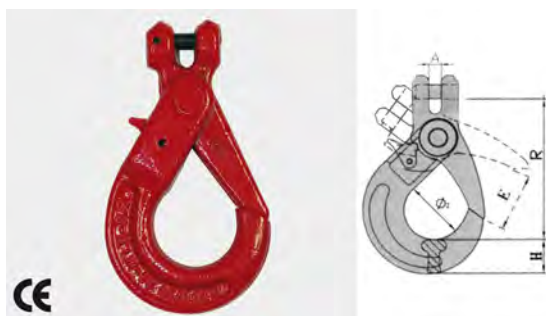

- Hook clevis self-locking degree 80
- Hook clevis self-locking position 80 pendants chain. Red.
- Hook clevis is mounted directly on the chain.
- Complies with EC-EN818, with safety factor 4: 1.
- Steel G / 80.

Code	Desc.	DN (mm)	Payload Kg (4:1)	E mm	A mm	H mm	Ø 2 mm	R (mm)
5070003340	37/7	7/8	2000	39	9,5	24	46	98
5070003350	37/10	10	3200	52	12	28	55	142

### Hook with safety grade 80



- Hook with safety grade 80 for pendants chain. Red.
- To be mounted on the connecting link.
- Complies with EC-EN818, with safety factor 4: 1.
- Steel G / 80.

Code	Desc.	Payload Kg (4:1)	A mm	E mm	D mm	Ø mm	L mm
5070003370	38/7	2000	11	30	26	25	133
5070003380	38/10	3200	15	34	39	38	167



## Chain tensioner



- Tendicatena perc catena R80
- Per catena da 8,10 e 13 mm
- Ganci completi di sicura per una maggior affidabilità
- Coefficiente di sicurezza: 2/1

Code	Desc. <i>d</i>	Payload <i>kg</i>	Length mm
5070003420	50	6300	745
5070003425	50/13	10000	795





## Car, cargo and civil air conditioning

Seals and connections ..... pag. 722  
Tools climate ..... pag. 728

Chemical products ..... pag. 732

## O-Ring special HNBR for car air-conditioning

VERDI ACCOPPIATI



MARRONI ACCOPPIATI



MARRONI ACCOPPIATI RENAULT



GUARNIZIONI SPACIALI MARRONI



- O-Ring special HNBR for car air-conditioning systems, resistant to gases used in air atmosphere, in specific forms for the major car manufacturers.
- Indicated in all the workshops, car electricians and coachwork for replacement after disassembly and reassembly of the plants.
- Resistance to gases R12, R134a, oils, temperatures between -40 and + 150 ° C.

Code	Desc.	Article	Applications
4140016840	4064-7,32x2	O-Ring verdi accoppiati	Alfa Romeo - Fiat - Iveco - Lancia - Peugeot
4140016850	4065-12,45x2	O-Ring verdi accoppiati	Alfa Romeo - Fiat - Iveco - Lancia - Peugeot
4140016860	4066-15,42x2	O-Ring verdi accoppiati	Alfa Romeo - Fiat - Iveco - Lancia - Peugeot
4140016910	4071-14,8x1,6	O-Ring marroni accoppiati	Renault
4140016920	4072-11,3x2,2	Guarnizioni speciali marroni	Alfa Romeo - Citroen - Daf - Fiat - Lancia - Peugeot - Renault - Volvo
4140016930	4073-14,8x2,2	Guarnizioni speciali marroni	Alfa Romeo - Citroen - Daf - Fiat - Lancia - Peugeot - Renault - Volvo
4140016940	4074-17,3x2,2	Guarnizioni speciali marroni	Alfa Romeo - Citroen - Daf - Fiat - Lancia - Peugeot - Renault - Volvo
4140016950	4075-20,2x2,2	Guarnizioni speciali marroni	Alfa Romeo - Citroen - Daf - Fiat - Lancia - Peugeot - Renault - Volvo

## Complete kit special seals



- Practical case full of all kinds of O-rings and special seals described above.
- It allows for all kinds of special seals always available, facilitating control of the amount.
- Contents: 5 pieces No. O-Ring 4064, 4065, 4066. No. 6 pieces O-Ring 4067, 4068, 4069, 4070, 4071. No. 3 pieces seals 4072, 4073, 4074, 4075.

Code	Desc.
4140301100	80



## Green OR-HNBR for air conditioners



TIPO ACCOPPIATO

- Or resistant to gases R12 and R134A used in all air conditioning systems.
- For all systems installed in cars, trucks, tractors, boats etc.
- Thermal resistance from - 40° to + 150°.
- Suitable for electricians mechanical body builders and all those who have to do with the air conditioning.
- Device disconnection cod. 477 00 01330, see tools.

CODE	DESC.	APPLICATION	CODE	DESC.	APPLICATION
414 00 16210	4002-6.60x1.50	A.R./Fiat/Ford/Lexus/Renault/Saab/Subaru/Toyota/Volvo	414 00 16510	4032-17.30x2.00	Audi/Honda/Mercedes/Porsche/VW
			414 00 16520	4033-20.12x2.00	Opel
414 00 16260	4007-6.30x1.60	Jaguar/Renault/Subaru	414 00 16540	4035-7.30x2.30	Rover
			414 00 16560	4037-17.10x2.30	Audi/Renault/VW
414 00 16290	4010-8.50x1.60	BMW	414 00 16570	4038-9.30x2.40	Opel/Rover
414 00 16300	4011-11.10x1.60	Jaguar	414 00 16580	4039-10.16x2.40	Opel
			414 00 16590	4040-10.80x2.40	A.R./Fiat/Ford/Honda/Jaguar/Lexus/Rover/Toyota
414 00 16320	4013-6.87x1.70	A.R./Honda/Jaguar/Rover/Toyota	414 00 16620	4043-13.80x2.40	Lexus/Honda/Rover/Toyota
414 00 16330	4014-4.48x1.78	Ford/Lexus/Renault/Saab/Subaru/Toyota/Volvo	414 00 16630	4044-14.40x2.40	Audi/Subaru/VW
414 00 16010	-6.07x1.78	Ford/Porsche/Renault/Rover/Subaru	414 00 16660	4047-19.80x2.40	Fiat/Ford/Honda/Lexus/Mercedes /Opel/Porsche/Toyota
414 00 16350	4016-6.40x1.78	A.R./Fiat/Lancia			
414 00 16020	-6.75x1.78	A.R./Fiat/Ford/Lancia/Rover	414 00 16670	4048-22.20x2.40	Saab/Volvo
414 00 16030	-7.65x1.78	A.R./Audi/BMW/Citroen/Fiat/Ford/Jaguar/Lexus/Mercedes/Opel/Peugeot/Porsche/Renault/Rover/Saab/Toyota/Volvo/VW	414 00 16680	4049-24.00x2.40	Audi/Opel/VW
414 00 16360	4017-8.13x1.78	Audi/Ford/VW	414 00 16090	15.88x2.62	A.R./BMW/Fiat/Lexus/Jaguar/Renault/Toyota
414 00 16370	4018-9.00x1.78	Audi/Mercedes/Opel/Porsche/Saab/Volvo/VW			
414 00 16040	-9.25x1.78	A.R./BMW/Fiat/Ford/Mercedes/Opel/Renault	414 00 16730	4053-9.30x2.52	BMW/Ford/Opel/Saab/Volvo
414 00 16390	4020-10.30x1.78	Ford	414 00 16740	4054-6.80x2.62	Opel
414 00 16050	-10.82x1.78	A.R./Audi/BMW/Citroen/Fiat/Ford/Jaguar/Lexus/Mercedes/Opel/Peugeot/Porsche/Renault/Rover/Saab/Subaru/Toyota/Volvo/VW	414 00 16750	4055-10.15x2.62	Opel
			414 00 16760	4056-17.13x2.62	Fiat/Opel
414 00 16410	4022-12.42x1.78	Saab/Volvo	414 00 16110	-18.72x2.62	A.R./Mercedes
414 00 16080	-14.00x1.78	A.R./Audi/BMW/Citroen/Fiat/Ford/Jaguar/Lexus/Mercedes/Opel/Peugeot/Porsche/Renault/Rover/Saab/Subaru/Toyota/Volvo/VW	414 00 16790	4059-10.80x3.50	Opel
414 00 16440	4025-15.60x1.78	Ford/Jaguar/Opel	414 00 16810	4061-20.40x3.50	A.R./Audi/Citroen/Ford/Jaguar/Lexus/Mercedes/Opel/Peugeot/Rover/Toyota
414 00 16450	4026-16.55x1.78	Audi/Citroen/Peugeot/VW	414 00 16830	4063-15.47x3.53	Opel
414 00 16100	-17.16x1.78	A.R./Audi/BMW/Fiat/Ford/Lexus/Mercedes/Opel/Renault/Saab/Subaru/Toyota/Volvo			
414 00 16460	4027-20.35x1.78	Audi/VW	<b>COUPLED TYPE</b>		
			414 00 16840	4064-7.32x2 tipo accop.	A.R./Fiat/veco/Lancia
			414 00 16850	4065-12.45x2 tipo accop.	A.R./Fiat/veco/Lancia
			414 00 16860	4066-15.42x2 tipo accop.	A.R./Fiat/veco/Lancia



## O-Ring NBR70 choke ring, green



- Special mixture with thermal resistance from -40° to + 150°.
- Material recommended for all types of gas used in air-conditioning systems on the market.

Code	Desc.	Ø int. mm	Spe. corda mm
4140016010	6,07x1,78	6,07	1,78
4140016030	7,65x1,78	7,65	1,78
4140016040	9,25x1,78	9,25	1,78
4140016050	10,82x1,78	10,82	1,78
4140016080	14,00x1,78	14,00	1,78
4140016090	15,88x2,62	15,88	2,62
4140016100	17,17x1,78	17,17	1,78
4140016110	18,72x2,62	18,72	2,62

## Assortment of green HNBR O-Ring



- Contents: 8 sizes of o-rings for air-conditioners.
- Total 160 pc.
- Supplied in plastic case art. 398 00 01700 200.
- NB assortments in composition may be subject to some modifications.

Code	Desc.
4140300800	12

### Kit contents

CODE	DESCR.	Qty
414 00 16010	6.07X1.78	20
414 00 16030	7.65X1.78	20
414 00 16040	9.25X1.78	20
414 00 16050	10.82X1.78	20
414 00 16080	14X1.78	20
414 00 16090	15.88X2.62	20
414 00 16100	17.17X1.78	20
414 00 16110	18.72X2.62	20
398 00 01700	200	1

## Assortment of OR-HNBR-clima



- Practical container with 24 sizes of green or's positions in HNBR.
- 15 pc.per compartment, total 360 or's.
- Contains the 3 sizes of bonded or for last generation Fiat systems.
- **The actual dimensions of each or contained in the compartment are given on the lid.**
- NB assortments in composition may be subject to some modifications.

Code	Desc.
4140300900	24

### Kit contents

CODE	DESCR.	Qty	CODE	DESCR.	Qty
414 00 16330	4.48X1.78	15	414 00 16050	10.82X1.78	15
414 00 16010	6.07X1.78	15	414 00 16610	13.50X2.40	15
414 00 16350	6.40X1.78	15	414 00 16080	14X1.78	15
414 00 16210	6.60X1.50	15	414 00 16090	15.88X2.62	15
414 00 16020	6.75X1.78	15	414 00 16450	16.55X1.78	15
414 00 16320	6.87X1.70	15	414 00 16100	17.17X1.78	15
414 00 16030	7.65X1.78	15	414 00 16510	17.30X2.00	15
414 00 16360	8.13X1.78	15	414 00 16810	20.40X3.50	15
414 00 16370	9.00X1.78	15	414 00 16840	7.32X2.00	15
414 00 16040	9.25X1.78	15	414 00 16850	12.45X2.00	15
414 00 16730	9.3X2.52	15	414 00 16860	15.42X2.00	15
414 00 16590	10.80X2.40	15	414 00 16110	18.72X2.62	15



## Mixed assortment for air-conditioners



- Mixed assortment for maintenance of air-conditioning systems.
- Kit includes: valve covers, valve cover mechanisms, valve cover caps and retrofit adaptors as well as tool for removing valve covers.
- Kit contains 58 pc. plus 1 tool.
- Indispensable for anybody who works with air conditioning systems: car electricians, mechanics, service stations etc.

Code	Description
4140400050	50 - mixed ass. for ac

### Composizione dell'assortimento e codici dei ricambi

**NB: GLI ASSORTIMENTI IN FASE DI COMPOSIZIONE POSSONO SUBIRE ALCUNE MODIFICHE**

	414 04 00060 - 5001 meccanismo corpo valvola standard R12/R134a n° 30 pezzi		414 04 00170 - 7012 corpo valvola di carica B.P. in alluminio M13X1 meccanismo standard (5001) n° 2 pezzi		414 04 00260 - 8013 adattatore retrofit per bassa pressione in acciaio 1/4" n° 2 pezzi
	414 04 00070 - 5003 meccanismo corpo valvola largo R12/R134a n° 5 pezzi		414 04 00180 - 7013 corpo valvola di carica B.P. in alluminio M13X1 meccanismo largo (5003) n° 2 pezzi		414 04 00100 - 6000 tappo corpo valvola di carica bassa pressione M9X1 n° 5 pezzi
	414 04 00080 - 5004 meccanismo corpo valvola largo per impianti denso R134a n° 5 pezzi		414 04 00190 - 7014 corpo valvola di carica A.P. in alluminio M12X1.25 meccanismo standard (5001) n° 2 pezzi		414 04 00110 - 6001 tappo corpo valvola di carica alta pressione M8X1 n° 5 pezzi
	414 04 00150 - 7010 corpo valvola di carica A.P. in alluminio M15X1 meccanismo standard (5001) n° 2 pezzi		414 04 00200 - 7015 corpo valvola di carica B.P. in alluminio M10X1.25 meccanismo standard (5001) n° 2 pezzi		414 04 00120 - 6003 tappo corpo valvola di carica bassa pressione M8X1 n° 5 pezzi
	414 04 00160 - 7011 corpo valvola di carica A.P. in alluminio M15X1 meccanismo largo (5003) n° 2 pezzi		414 04 00250 - 8012 adattatore retrofit per alta pressione di alluminio 1/4" senza meccanismo n° 2 pezzi		397 00 03300 - 33 utensile per meccanismi corpi valvola

## Valves for A / C systems

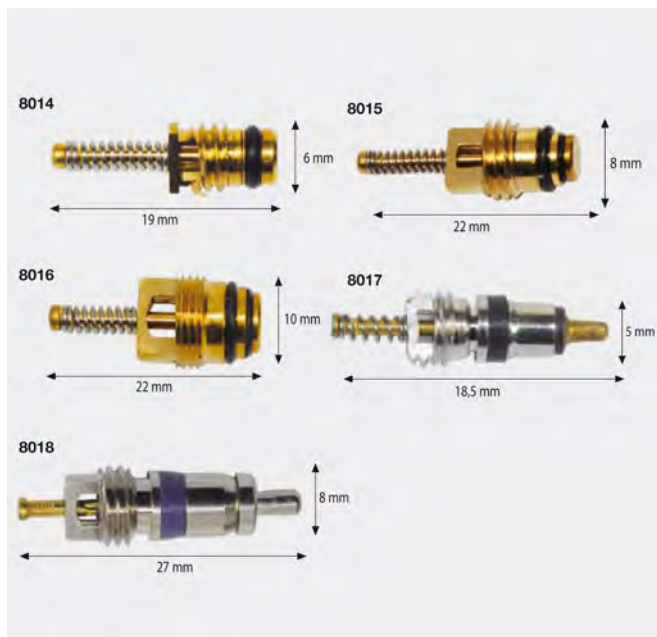

- Mechanisms valve parts for circuits of air-conditioning of motor vehicles.
- Allow to quickly restore the tightness of the valves of high and low pressure.

Code	Description	Dimensions	Applications
4140400270	8014 Valvola a spillo	M6X0,75	-
4140400280	8015 Valvola a spillo	M8X1,0	-
4140400290	8016	-	Autoveicoli gruppo GM
4140400300	8017	-	Autoveicoli gruppo Renault
4140400310	8018	-	Autoveicoli gruppo Audi-VW

## Valves for air conditioning systems R1234yf



- Internal mechanisms of spare valves for car conditioning system. They allow to restore the tightness of the faulty valves quickly.
- Specific for air conditioning systems equipped with cooling gas R1234yf.

Code	Description	Dimensions
4140400360	8023	19,0 x 5,12 mm
4140400370	8024	21,8 x 8,0 mm
4140400380	8025	22,1 x 9,8 mm

## Springlock releases for A / C systems



- Series of releases for specific fittings Springlock circuit of air conditioning for cars and trucks.
- Suitable for all workshops, car electricians, body shops who need to perform disassembly circuit for repairs and maintenance.
- Complete kit that allows removal without damage to the fittings used on many brands of vehicles.
- Content: release red pipe G6. release blue pipe G8. release black tube G10. release white tube G12.

Code	Desc.
4770004600	320

## Device for disconnection fuel hoses and air conditioning

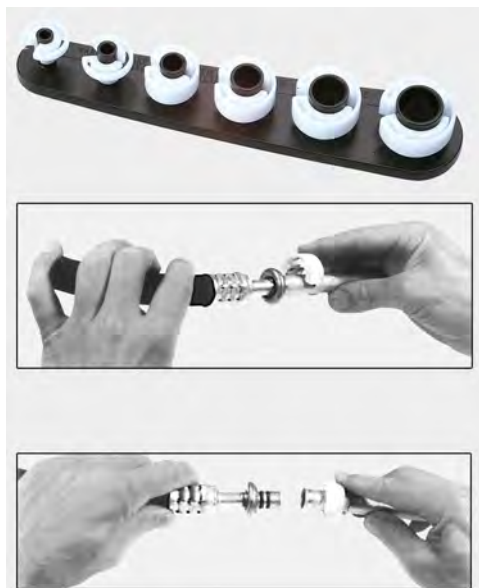

- Set of 6 tools to disconnect the quick-release devices that are mounted on the tubes of the air conditioning and the fuel pipes of all models of cars: Ford, Opel etc.
- The set includes the following sizes: 5/16" - 3/8" - 1/2" - 5/8" - 3/4" - 7/8".

Code	Desc.
4770001330	133

## Quick coupler for high pressure R134a



- Quick connection with metal tap taken high pressure weather systems operating with gas R134a.
- Article indicated as replacement for all charging stations air conditioners.
- Thread connecting the pipes 1/4 sae threaded male or female M14.

Code	Desc.	Thread
4140400320	8019	Maschio 1/4 SAE
4140400340	8021	Femmina M14



## Low pressure quick coupler for R134a



- Quick connection with metal tap took low-pressure weather systems operating with gas R134a.
- Article indicated as replacement for all charging stations air conditioners.
- Thread connecting the pipes 1/4 sae threaded male or female M14.

Code	Desc.	Thread
4140400330	8020	Maschio 1/4 SAE
4140400350	8022	Femmina M14

## Quick Hitch special charging high pressure R134a



- Special quick coupling for high pressure side, which is essential to solve the problems during maintenance of existing space on the drive specified.
- Suitable for all workshops, car electricians, body shops who need to perform disassembly circuit for repairs and maintenance.
- The connector allows to easily and quickly extend the original attack of the machine charging, allowing to reach without disassembling other details the outlet of high pressure.

Code	Desc.	Application
4770004650	325	BMW serie 5 – Ford S Max – Ford Galaxy – Volvo S3 – Mercedes SLK

## Quick Hitch special charging high pressure R134a



- Special quick coupling for high pressure side, which is essential to solve the problems during maintenance on the car described, on which there is no connection for low pressure.
- Suitable for all workshops, car electricians, body shops who need to perform disassembly circuit for repairs and maintenance.
- The connector allows to connect with the low pressure side of the machine to the charging circuit of the car, missing the origin of a specific attack, and recharge the circuit.

Code	Desc.	Applications
4770004660	326	Auto del gruppo PSA-Renault-Opel

7

## High/low pressure quick couplings for R134a with protection



- Quick couplings for recharging stations of gas R134a, completely made of metal, reliable and safe. Equipped with tap and protection against impacts and crushing.
- Equipped with standard adapter that changes, at will, the threading from female M 14x1.5 to male 1/4 SAE for the utmost reliability.

Code	Desc.	Presi	Color
4140400390	8026	Low pressure	Blue
4140400400	8027	High pressure	Red

## High/low pressure quick couplings for R1234yf with protection



- Quick couplings for recharging stations of gas R1234yf, completely made of metal, reliable and safe. Equipped with tap and protection against impacts and crushing.
- Equipped with standard female threading M 12x1.5.

Code	Desc.	Presa	Color
4140400410	8028	Low pressure	Blue
4140400420	8029	High pressure	Red

## Adapters for high/low pressure quick couplings



- Adapters complete with seals, useful to transform the female fittings of quick couplings for air conditioning machine. Made of brass with O-rings suitable for cooling gas.
- They change the female threading M 12 x 1.5 in into male threading respectively 1/4 SAE or 3/8 SAE.

Code	Desc.	Thread
4140400430	8030	M12 > 1/4 SAE
4140400440	8031	M12 > 3/8SAE

## Extension for low pressure recharge R1234yf



- Extension that can be mounted on the low pressure socket of the air conditioning systems charged with gas R1234yf and allows to work on all car models having the socket in sunken and hidden position, hardly accessible (e.g. Opel and Ford cars).
- Completely made in metal and equipped with the valve against the gas leaks.

Code	Desc.
4140400450	8032

## PAG synthetic oil Universal for air conditioners



- PAG synthetic oil admixed with anti-friction and anti-wear products for air conditioning systems of cars loaded with R134a, universal, miscible with each other type of PAG oil used at the origin.
- Usable by all the workshops for the charging operations and maintenance.
- The particular formulation allows miscibility and replacement with any kind of gradation of synthetic oil p, increasing protection of the compressor, eliminating noises and squeaks and increasing system performance. Extend the life of moving parts.
- The use allows to the system to maintain in the time the original performance, increasing comfort inside the vehicles for a long time.
- USE
- Enter the plant at the time of charging, following the manufacturer's instructions.
- **WARNING:** the oil absorbs moisture from the atmosphere. Do not open the container before use, and do not leave it open for not compromising functionality.

Code	Desc.	Content It
4110017670	4465	1

7

## Universal PAG oil for R1234yf



- Multi-viscous PAG synthetic oil, suitable for the change or the addition in the air conditioning systems using cooling gas R1243yf.
- It can be mixed with any type of PAG oils used in original equipment without contraindications and ensures a perfect lubrication and a long life to the system components. It does not damage seals and fittings.
- **Attention:** oil absorbs the air humidity, do not open the container before use and do not leave it open for long time so as not to affect its operation.

Code	Desc.	Content
4110020390	6357	1 L

## Universal POE oil for hybrid/electric cars



- Multi-viscous POE synthetic oil, suitable for the change or the addition in the air conditioning systems that use electric compressors: hybrid or electric cars.
- It can be mixed with all types of POE oils used in original equipment without contraindications and ensures a perfect lubrication and a long life to the system components. It does not damage seals and fittings.
- **Attention:** oil absorbs the air humidity, do not open the container before use and do not leave it open for long time so as not to affect its operation.

Code	Desc.	Content
4110020400	6358	250 ml

## Universal tracer fluid for air conditioner



- Universal fluorescent tracer fluid for air conditioning and cooling circuits. Used to trace gas leaks, including microscopic, in any section of a system.
- Compatible with all types of gas used both in the past and currently. Does not interfere with any lubricants contained inside or with mechanisms and exchangers. Will not damage metals or rubber.
- Leaks are shown as fluorescent in the different parts of the system when lit with ultra-violet light, as per our code number 4110016110-3860, the fluorescence will show the leak.
- Available in 250 ml packages for 33 applications on vehicles, or in single-dose syringes (7.5 ml, 12 pieces) complete with re-usable connection with R134A gas adaptor.

Code	Desc.	Content
4110016050	3835	250 ml.
4110020290	6346	12 syringes + R134A adapter





## Tracer liquid for air conditioning systems with R1234yf



- Fluorescent tracer fluid for air conditioning circuits containing gas R1234yf. Used to trace gas leaks, including microscopic, in any section of a system.
- It does not interfere with the lubricants contained inside nor with mechanisms and exchangers and does not deteriorate metals and rubbers.
- Leaks are shown as fluorescent in the different parts of the system when lit with ultra-violet light, as per our code number 4110016110-3860, the fluorescence will show the leak.
- Available in 250 ml packages for 33 applications on vehicles, or in single-dose syringes (7.5 ml, 12 pieces) complete with re-usable connection with R1234yf gas adaptor.

Code	Desc.	Content
4110020325	6350	250 ml
4110020330	6351	12 syringes + adaptor R1234yf

## Leak sealer for air conditioning systems with R1234yf



- Leak sealer for air conditioning system containing R1234yf gas, which allows to repair the micro-leaks of the system, especially the most inaccessible and the least traceable ones, in a safe and long-lasting manner.
- It does not interfere with the lubricants contained inside nor with mechanisms and exchangers and does not deteriorate metals and rubbers.
- The efficiency of the product remains even after repairing as it remains in the system thus allowing the automatic repairing of other future small leaks throughout the system life.
- Available in single-dose package (30 ml) complete with re-usable connection with R1234yf gas adaptor.
- **How to use:** the air conditioning system must be emptied and placed under vacuum before inserting the product. It is advisable to always replace the filter drier of the car before refilling the system. Strictly follow the instructions inserted in the product package.
- **Attention:** the product can repair only small leaks. For huge leaks, it is necessary to intervene mechanically. The amount of the product contained in the syringe is enough for the treatment of systems with max. 1.5 Kg. of gas. In case of larger amounts, use more packages at a time.

Code	Desc.	Content
4110020340	6352	30 ml

## Spray cleaner for tracers



- Special spray cleaner for the easy and quick removal of all tracer liquids from the outside of the system after use.
- It allows an immediate removal of the fluorescent liquids so as to be able to repeat the tests after repairing or before the redelivery of the vehicle.

Code	Desc.	Content
4110020370	6355	400 ml

## Electronic leak detector kit with nitrogen/hydrogen



- Innovative system for detection of gas leaks for conditioning systems of any kind of vehicles. The system is based on the system filling of an inert gas mixture consisting of nitrogen and hydrogen and on the search of leaks by means of electronic instrument, even microscopic.
- The use of the system permits considerable savings, avoiding to refill the system with cooling gas for detecting leaks. The latter is replaced with a inert gas mixture, much cheaper, totally neutral if dispersed in the environment, safe for all parts that make up the system, easily identifiable with the electronic instrument supplied.
- Extremely simple to use, just refill the empty air conditioning system with the gas contained in the bottle up to a pressure of about 1,5-2 bars and trace any leak by means of the "electronic nose", which will detect the presence of the hydrogen coming out from the system.
- Each 1 litre allows up to 3 fillings of standard conditioning systems.
- Kit contents: 1 electronic leak detector, 1 bottle of nitrogen/hydrogen mixture (1 litre), 1 pressure gauge with pipe, 1 pressure regulator, 1 quick coupling for high pressure R134a, 1 quick coupling for high pressure R1234yf, 1 adapter M12x1,5/M1/4SAE for R1234yf, 1 extension pipe (1.5 m) F-F ¼ SAE, storage and transport case.

Code	Desc.	Content
4770007140	778	Complete kit for leak detection (italy)
4770007150	779	Complete kit for leak detection ( France)
4110020380	6356	1 L spare bottle

## Universal electronic leak detector



- Electronic leak detector for a simple and quick detection of cooling gas leaks by means of LED ramp: r134a, R404a, R407c, R410a, R22, R1234yf and hydrogen.
- The use of the appliance permits the simple and quick detection of gas leaks, even small, also in hidden points that are hardly accessible. It makes repair of air conditioning system faster and avoids the insertion of tracer and fluorescent liquids into the system.

Code	Desc.
4770007160	780

## Lamp and glass for leak-marker A/C



- Special led UV rays lamp, flexible, for the highlighting of leaks in air-conditioned systems through the use of special marking liquids, like our items 411 00 16050-3835, 411 00 16060-3840.
- The small and handy form and the flexibility allow to reach all points in the systems, even the most inaccessible ones.
- Packaging including special protection glasses to use always during the use of the lamp.
- Works with 3 AA batteries 1,5V (not included)

Code	Desc.	Content
4110016110	3865	Flexible lamp + plastic protection glasses

## Stop Leak universal air conditioning with tracer



- Liquid stop Leak universal for all types of air conditioning systems and cargo cars operating on any type of refrigerant gas.
- Suitable for professional use by all workshops equipped with charging station, mechanics, body shops, car electricians, etc.
- The same product are turafalle and dye, so you can easily check the success of the repair and to report any further losses in the future.
- The liquid turafalle universal and 'packaged in disposable vacuum bottle, complete with quick universal low pressure R134a, adapters may' be applied to all types of attacks used in domestic cars and cargo. It does not damage the plant, charging stations, repairs all micro leaks and remains in circulation for future losses.
- How to use: the air conditioning circuit must be emptied and placed under vacuum before the insertion of the product.
- It 'always best to replace the filter drier car before refilling the system. Carefully follow the instructions included in the product box.
- Caution: the product can 'repair only losses of small entities', difficult to locate. For large holes and 'need to act in a mechanical way. The amount 'of product contained in the bottle and' sufficient for the treatment of circuits with maximum 1.5 kg of gas inside. if the amount 'above must enter more' packages at a time.

Code	Desc.	Content g/ml
4110019210	5840	42/30

## Kit stop Leak / tracer universal syringe



- Liquid stop Leak universal for all types of air conditioning systems and cargo cars operating on any type of refrigerant gas.
- Suitable for professional use by all workshops equipped with charging station, mechanics, body shops, car electricians, etc.
- The same product are turafalle and dye, so you can easily check the success of the repair and to report any further losses in the future.
- The liquid turafalle universal and 'packaged in disposable syringe, complete with quick universal low pressure r134a, adapters may' be applied to all types of attacks used in car plants and cargo. It does not damage the plant, charging stations, repairs all micro leaks and remains in circulation for future losses.
- How to use: the circuit a / c must be emptied and placed under vacuum before the insertion of the product. and 'always preferable to replace the filter drier car before refilling the system. follow the instructions included in the product box.
- Caution: the product can 'repair only losses of small entities', difficult to locate. for large flaws and 'necessary to act in a mechanical way. the amount 'of product contained in the bottle and' sufficient for the treatment of circuits with maximum 1.5 kg of gas inside.
- In the case of quantities 'superiors must enter more' packages at a time.

Code	Desc.	Content g/ml
4110019600	6160	42/30

7

## Anti-mould sanitizer for air conditioners



- **CHARACTERISTICS**
- Active product for deep cleaning, sanitizing, and elimination of all kinds of dirt, mould, bacterium and bad odours from air conditioning in vehicles.
- In no way does it damage plastic, fabrics or any other coverings inside the vehicle.
- It comes with a 50 cm. long multi-hole probe, for easily reaching all internal parts in the air conditioning system.
- **ADVANTAGES**
- Prevents formation of bad odours and ailments to respiratory system due to dirt, mould and bacterium that form on the evaporator and inside piping of airflow.
- **HOW TO USE**
- Remove the anti-pollen filter, if necessary replace it after treatment, and open all air vents inside the vehicle.
- With the motor running, turn the air conditioning on at maximum level. Insert the probe as deeply as possible in the external air duct; spray about half of the product from the cylinder through the opening.
- Turn the air conditioning off, insert the probe as deep down as possible in each air vent, and as you spray begin to extract the probe, for treating all parts on the system.
- Let the product evaporate for a few minutes, and reassemble the anti-pollen filter.

Code	Desc.	Content ml
4110016540	4085	200



## Mono use anti-odour sanitizer (One Shot) FOR INDOOR ENVIRONMENTS



Code	Desc.	Content ml
4110016550	4090	150

### • CHARACTERISTICS

- Active sanitizer for indoor use, for inside vehicles, and for air conditioning systems in vehicles, comes in mono use cylinder (One Shot) with complete emptying of product. It takes away all types of dirt, mould and bacterium from indoor environments, inside cars and from the air conditioning system, which cause bad odours and allergic reactions. It affectively removes odours caused by transportation of pets.
- The spray saturates the environments and easily reaches all hidden corners, with an effective purifying action that removes all accumulated residues.
- Ideal for sanitizing small spaces such as, offices, bathrooms, medical offices, environments where animals live, etc.

### • ADVANTAGES

- No allergic reactions to bacterium or mould thanks to the total elimination of the same.
- Enhances liveability in closed environments, in the car and in the home.

### • HOW TO USE

- In the car: open all cases, closed compartments, all air vents and close the windows.
- With the engine running, turn the air conditioning on at maximum level with air recycler on and ventilator on at maximum speed.
- Place the cylinder on the car floor in a central position, push the button for total distribution and close all doors.
- Wait till the cylinder is empty, let stand for about 15 minutes, then open the doors and let air circulate for a few minutes. If necessary, replace the anti-pollen filter.
- In environments: open all drawers, close the windows and place the cylinder in the middle of the room.
- Push the button for total distribution and leave the room.
- Wait about 25/30 minutes, open and let room air before entering.

## Spray kit for cleaning air conditioning system pipes



- Handy and complete spray intended for the deep cleaning of the pipes and of all parts of the air conditioning systems consisting of a 600 ml disposable bottle of detergent, pistol with 1 m extension, and tap.
- Very easy to use, just lay the rubber end on the outlet pipe of the compressor, leaving the inlet pipe disconnected, and empty the bottle into the system completely. The liquid will carry out a deep cleaning from oils, leak sealer, dirt and will evaporate quickly.
- Restores the system potential, removes the possibility of breakage due to dirt, brings the whole internal part of the treated systems back to the original conditions.
- Compatible with any system with any kind of cooling gas used.

Code	Desc.	Content
4110020350	6353	Complete 600 ml bottle kit and pistol with extension
4110020360	6354	600 ml spare bottle of detergent

## Nastro in gomma espansa



- Nastro a cellule chiuse in polietilene con superficie retinata e adesivizzata. colore nero.
- Ideale per la coibentazione di tubazioni calde e fredde. Le superfici da ricoprire devono essere pulite, asciutte e prive di grassi.
- Ottime caratteristiche di elasticita' e plasticita'.
- Puo' essere verniciato con pitture ad acqua.
- Temperature d'impiego: -50°C/+105°C.
- Coefficiente di conducibilita' termica lambda: +50°C 0,039 W/m °K.
- Autoestinguento classe 1.

Code	Desc.	Width tape mm	Thickness mm	Length mt
4840001500	50x10x3	50	3	10

## Nastro gomma espansa clima



- Nastro a cellule chiuse in polietilene con superficie retinata e adesivizzata. Colore grigio.
- Ideale per la coibentazione di tubazioni calde e fredde, e per impianti d'aria condizionata. Per l'utilizzo le superfici da ricoprire devono essere pulite, asciutte e prive di grassi.
- Ottime caratteristiche di elasticita' e plasticita'.
- Puo' essere verniciato con pitture ad acqua.
- Temperature d'impiego: -40°C/+80°C.
- Coefficiente di conducibilita' termica lambda: +40°C 0,039 W/m °K.
- Autoestinguento classe 1.

Code	Desc.	Width tape mm	Thickness mm	Length mt
4840001510	50x10x3 CL	50	3	10

## Sanificante spray per filtri clima



- Prodotto sanificante e deodorante spray ideato per la perfetta pulizia e igienizzazione dei filtri degli impianti di condizionamento dell'aria. indicato per gli installatori e i manutentori degli impianti di climatizzazione civile e industriale, termoidraulici. il prodotto si applica sui filtri dopo la pulizia avendo cura di bagnare la superficie uniformemente, successivamente si lascia funzionare l'impianto fino alla completa asciugatura evitando di respirare i residui che ne fuoriescono.
- Si utilizza anche settimanalmente per la manutenzione dei filtri ed evitare la proliferazione dei batteri e delle muffe. il prodotto e' efficace su: escherichia coli, proteus mirabilis, pseudomonas aeruginosa, staphylococcus aureus, candida albicans, saccharomyces cerevisiae.
- Prodotto a norma con la legge 155 sull'h.a.c.c.p. dopo l'utilizzo il prodotto lascia un leggero e gradevole profumo floreale.

Code	Desc.	Cont. ml
4110019630	6175	400

## Detergente sanificante per filtri clima



- Detergente e sanificante in un unico prodotto liquido indicato per la pulizia profonda di pacchi alettati e filtri degli impianti di refrigerazione. Distrugge batteri, spore, muffe e funghi che si creano durante il funzionamento.
- Distrugge i cattivi odori lasciando un gradevole e leggero profumo.
- Indicato per gli installatori e i manutentori degli impianti di climatizzazione civile e industriale, termoidraulici, ristoratori.
- Si puo' utilizzare anche su generatori di aria calda, cappe di aspirazione di cucine, bar e ristoranti, coperture e piani di lavoro, teloni in pvc, ecc.
- Scioglie lo sporco grasso di smog e polvere, elimina funghi e muffe, uccide legionella, salmonella e altri virus.
- Prodotto a norma con la legge 155 sull'h.a.c.c.p.
- Il prodotto si utilizza puro o diluito al 5%-10% in acqua a seconda dell'intensita' dello sporco. Lasciare agire qualche minuto e risciacquare abbondantemente con acqua. Fare asciugare all'aria aperta.

Code	Desc.	Cont. KG
4110019640	6180	5

## Pastiglie igienizzanti per climatizzatori



- Pastiglie igienizzanti per prevenire la formazione, nelle vaschette di scarico condensa, di alghe, mucillagini, batteri e limo che intasano i condotti di scarico e provocano cattivi odori, oltre ad otturare gli scarichi della condensa. indicato per gli installatori e i manutentori degli impianti di climatizzazione civile e industriale, termoidraulici.
- Ottimo per la normale manutenzione da parte degli utenti. riporre una pastiglia nella canalina del fan-coil o nella vaschetta di raccolta della condensa dello split nel punto piu' lontano dallo scarico.
- La durata di una pastiglia dipende dall'utilizzo, in genere si usano 1-2 pastiglie ogni 15-20 giorni per impianti fino a 12000 btu.

Code	Desc.	Confection
4110019660	6190	Blister da 8 pastiglie

## Detergente spray per climatizzatori



- Detergente schiumogeno in bombola spray creato per la perfetta pulizia dei pacchi radianti degli impianti di climatizzazione civile e industriale. indicato per gli installatori e i manutentori degli impianti di climatizzazione civile e industriale,
- Termoidarulici. la schiuma prodotta aderisce perfettamente alle superfici, anche verticali, scioglie ogni tipo di sporco, anche il piu' ostinato, e viene eliminata semplicemente risciacquando i pezzi trattati.
- Prodotto a norma con la legge 155 sull'h.a.c.c.p. nel periodo estivo il prodotto viene eliminato dalla condensa dei pacchi radianti, evitando cosi' il
- Risciacquo. la bombola funziona in tutte le posizioni, permettendo di raggiungere i punti piu' nascosti

Code	Desc.	Cont. ml
4110019620	6170	600





## Manual gear

Wrenches . . . . .	pag. 744	Terminals and extractors . . . . .	pag. 903
Compasses and accessories . . . . .	pag. 764	Tools for building . . . . .	pag. 919
Screwdrivers . . . . .	pag. 799	Phasing kit . . . . .	pag. 922
Inserts hexagonal . . . . .	pag. 812	Specific tooling for bodywork and workshop . . . . .	pag. 943
Pliers . . . . .	pag. 835	Filter wrenches . . . . .	pag. 997
Pipe cutters . . . . .	pag. 859	Oilers, lubricators, air operated pumps and oil . . . . .	pag. 1005
Hammers and chisels . . . . .	pag. 862	Control and measurement instruments . . . . .	pag. 1016
Thermoformed . . . . .	pag. 872	Cans, funnels and gatherers . . . . .	pag. 1054



## Keys "T" articulated Meccanocar

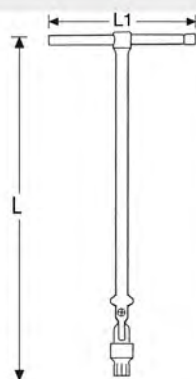

- Hexagonal mouth.
- Knotted universal plug and sliding friction.
- Made of chrome-vanadium.
- Glossy finish.
- On the joint are inserted special spiral springs so as to ensure functionality 'in time and to prevent its loosening.

Code	Desc. Measure	L mm	L1 mm
4200027106	6	390	145
4200027107	7	390	145
4200027108	8	390	145
4200027109	9	390	145
4200027110	10	405	160
4200027111	11	405	160
4200027112	12	405	160
4200027113	13	430	175
4200027114	14	430	175
4200027115	15	430	175
4200027116	16	430	175
4200027117	17	445	200
4200027118	18	445	200
4200027119	19	500	230
4200027122	22	500	230

8

## WRENCHES SERIES "T" ARTICULATED

Code	Description	Content/size
4200027100	Series 5 keys T jointed 10-22	10-13-17-19-22

## Keys "T" series long articulated

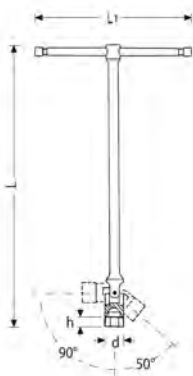

- Hexagonal mouth.
- Chrome vanadium chrome plated polished head.
- Accompanied by articulation braking so as to allow the pre-positioning of the tool.

Code	Desc. Ø mm	d mm	h mm	L mm	L1 mm
4430018142	271 L - 10	14,6	10	930	160
4430018152	271 L - 12	14,6	10	1063	160
4430018172	271 L - 13	18,7	10	1100	180
4430018182	271 L - 14	19,7	10	1100	180
4430018192	271 L - 15	20,9	11	1100	200
4430018202	271 L - 16	22,0	11	1100	200
4430018212	271 L - 17	23,4	12	1100	215
4430018222	271 L - 18	24,7	12	1100	200
4430018232	271 L - 19	26,0	13	1100	240
4430018262	271 L - 22	29,7	14	1100	240

## Keys "T" joint spine candles



- Joint shaft drive.
- Removable sliding rod.
- Chrome vanadium steel.
- Chrome plated, polished head.
- Accompanied by articulation braking so as to allow the pre-positioning of the tool.
- Rubber gasket for retaining the spark plug.
- For cars, motorcycles and scooters.
- 1 Hexagonal.
- \* Polygon jointed thin engine fire 16V.

Code	Desc.	Ø mm	Ø pollici	c	L mm
4430038300	429	16	5/8	170 mm	450
4430017000	268	20,8	13/16	220 mm	545

## Meccanocar pipe wrenches with through hole



- The deep well socket on the long side and the through hole on the short side give the keys a great adaptability and are indispensable in many processes.
- Mouth short side polygon.
- Mouth long side hex \*.
- \* **Measures 6 and 7 are both with 2 mouths hexagonal.**
- Matte finish, polished heads.
- Stainless steel.

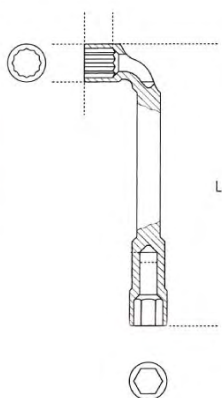

Code	Desc. Measure	L external mm
4200027206	6*	106
4200027207	7*	111
4200027208	8	118
4200027209	9	124
4200027210	10	133
4200027211	11	139
4200027212	12	148
4200027213	13	155
4200027214	14	163
4200027215	15	170
4200027216	16	180
4200027217	17	190
4200027218	18	200
4200027219	19	210
4200027220	20	220
4200027221	21	230
4200027222	22	230

## SERIES WRENCHES PIPE

Code	Description	Content/size
4200027200	Series 11 PCS.	6-7-8-10-11-12-13-14-17-19-22



## Keys "T" Allen Meccanocar



- Keys 3 heads.
- Made of chrome-vanadium.
- Short sliding part
- Hexagonal profile
- For screws with a hexagonal socket.

Code	Desc. Measure	L mm	Width Mm L1	h head mm P
4200058902	589-2	130	65	5
4200058925	589-2,5	130	65	5
4200058903	589-3	150	65	6
4200058904	589-4	180	90	8
4200058905	589-5	180	90	9
4200058906	589-6	215	105	10
4200058908	589-8	250	125	12
4200058910	589-10	300	145	14
4200058912	589-12	315	165	17

## Keys T fixed Meccanocar long type



- Keys t fixed, sliding plug.
- Chrome-vanadium steel, matte finish.
- A uni 6742 din 3112.
- A hexagonal mouth.
- Plug with sliding mounted.

Code	Desc. / Meas. mm	Length L1 mm	Length L2 mm
4200027006	6	215	165
4200027007	7	215	165
4200027008	8	235	165
4200027009	9	235	165
4200027010	10	260	180
4200027011	11	260	180
4200027012	12	260	180
4200027013	13	260	180
4200027014	14	260	220
4200027015	15	285	220
4200027016	16	285	220
4200027017	17	285	240
4200027019	19	310	240
4200027022	22	310	300
4200027024	24	310	300

## Keys "T" Allen articulated



- Chrome vanadium steel chrome plated.
- Junction thin measuring 7\*.
- Joint framework.

Code	Desc. Ø	L	h
		mm	mm
4200098300	2245 - 3	405	140
4200098310	2245 - 4	405	140
4200098320	2245 - 5	415	140
4200098330	2245 - 6	415	160
4200098335	2245 - 7*	400	165
4200098340	2245 - 8	415	160
4200098350	2245 - 10	430	160

## Keys "T" jointed square drive



- Chrome vanadium steel chrome plated.
- With universal joint.

Code	Desc. Ø mm	L	h
		mm	mm
4430043620	483Q - 1/4	385	165
4430043630	483Q - 3/8	450	175
4430043640	483Q - 1/2	495	180

## T-wrench jointed att. 1/4 "



- Wrench with reversible ratchet head 1/4 ".
- T-handle for a secure grip.
- 30cm long shaft. to work in depth.
- The ratchet is mounted on pivot pins.
- It adapts to any work situation.
- Particularly suitable for working in confined spaces, in engine compartments, on scooters and maxi scooters.

Code	Desc.
4770002370	237

## Keys "T" fixed Torx



Code	Desc. Ø	Leng. mm
4430047900	868 - T6	125
4430047902	868 - T7	125
4430047904	868 - T8	125
4430047906	868 - T9	125
4430047908	868 - T10	125
4430047910	868 - T15	125
4430047912	868 - T20	125
4430047914	868 - T25	180
4430047916	868 - T27	180
4430047918	868 - T30	180
4430047920	868 - T40	210
4430047922	868 - T45	210
4430047924	868 - T50	250
4430047926	868 - T55	300

- In chrome vanadium steel, chrome plated.
- Fixed plug.

## Keys "T" jointed profile Torx® female

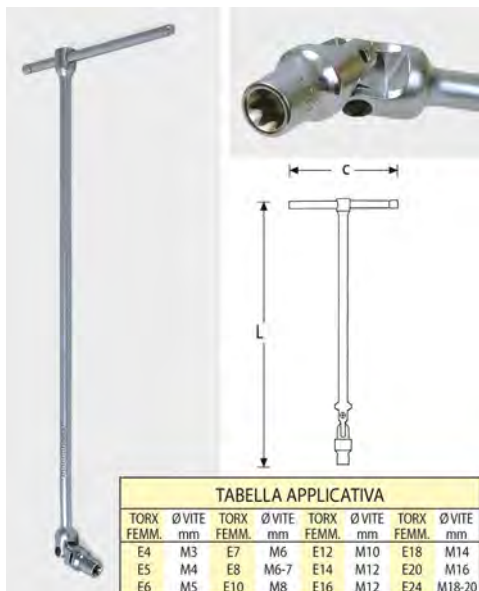

- Joint shaft drive.
- Spring clutch for pre-positioning of the head.
- Removable sliding rod.
- Chrome vanadium steel.
- Chrome plated, polished head.

Code	Desc.	Ø mm	L mm	c mm
4430049314	916 - E6	5,74	399	165
4430049316	916 - E7	6,22	399	165
4430049318	916 - E8	7,52	399	165
4430049320	916 - E10	9,42	432	175
4430049322	916 - E12	11,17	432	175
4430049324	916 - E14	12,90	499	180
4430049326	916 - E16	14,76	499	180
4430049328	916 - E18	16,70	499	180
4430049330	916 - E20	18,45	523	220

TABELLA APPLICATIVA							
TORX FEMM.	Ø VITE mm	TORX FEMM.	Ø VITE mm	TORX FEMM.	Ø VITE mm	TORX FEMM.	Ø VITE mm
E4	M3	E7	M6	E12	M10	E18	M14
E5	M4	E8	M6-7	E14	M12	E20	M16
E6	M5	E10	M8	E16	M12	E24	M18-20

## KEYS SERIES "T" SWIVEL

- Profile Torx female.
- Series of 9 keys.

Code	Desc.	Content
4430049334	916E/9	FROM E6 TO E20



## Keys "T" articulated male profile Torx®



- Joint shaft drive.
- Clutch spring for pre-positioning of the head.
- Removable sliding rod.
- Chrome vanadium steel.
- Chrome plated finish with burnished tip.

Code	Desc.	Ø mm	L mm	b mm
4430049336	917TX - T20	3,86	403	165
4430049338	917TX - T25	4,43	403	165
4430049340	917TX - T27	4,99	403	165
4430049342	917TX - T30	5,52	436	175
4430049344	917TX - T40	6,65	436	175
4430049346	917TX - T45	7,82	436	175
4430049348	917TX - T50	8,83	468	175
4430049350	917TX - T55	11,22	500	180

TABELLA APPLICATIVA							
TORX MASC	ØVITE mm	TORX MASC	ØVITE mm	TORX MASC	ØVITE mm	TORX MASC	ØVITE mm
T6	M2	T10	M3-3,5	T27	M4,5-5-6	T50	M10
T7	M2,5	T15	M3,5-4	T30	M6-7	T55	M12
T8	M2,5	T20	M4-5	T40	M7-8	T60	M14
T9	M3	T25	M4,5-5	T45	M8-10	T70	M16

## KEYS SERIES "T" ARTICULATED

- Profile Torx male.
- Series of 8 keys.

Code	Desc.	Content
4430049354	917TX/8	FROM T20 TO T55

## Adjustable wrenches



- Chrome vanadium chrome plated polished head.
- UNI 6734 DIN 3117.
- The inclination of 15 ° of the head relative to the handle allows to obtain an angle of carry-over of 30 ° overturning the key.

Code	Desc.	Ø mm	L mm
4430015700	253-200	24	200
4430015710	253-250	30	254
4430015720	253-300	35	309

## Spanner and pipe turn



- Spanner steel.
- Titacrom® special coating protects the tool from: scratches, oils, rust and corrosion caused by acids.
- Innovative quick release of the polygon to transform the tool to tighten nut key giratubo.
- With millimeter scale (0-30mm) which detects fast measurement.
- Intended Use: plumbers, electricians, carpentry, car bodies.
- Suitable for loosening and tightening pipes and nuts also damaged.

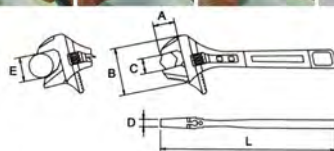

Code	Desc.	L mm	A mm	B mm	C mm	D mm	E	Weight gr.
4430055155	1141	250	30	69	29	8,4	1" 1/4	550
4430055160	1142	300	35	82	33,5	10,2	1" 1/2	850



## Adjustable spanner with ratchet mechanism



- Adjustable spanner with ratchet mechanism
- Can be utilised as a normal spanner
- Ratchet mechanism can be utilised without having to remove the spanner from the nut
- 0-25mm / 0-1" double scale
- Ergonomic handgrip in slip-resistant material



Code	Description
4430058200	1782-210 Adjustable spanner with ratchet mechanism

## Wrench double heavy series Meccanocar



- Wrench billet.
- With through-hole for the use of tie rods.
- A uni-6745 din 896.
- Satin finish, polished heads.

Code	Description	Leng. mm	Opening H1 mm	Opening H2 mm
4200098700	6x7	105	10	11
4200098710	8x9	110	13	13
4200098715	10x11	120	16	17
4200098720	12x13	135	18	19
4200098725	14x15	145	20	22
4200098730	16x17	155	23	24
4200098735	18x19	165	25	26
4200098740	20x22	175	28	30
4200098770	10-22 asta manovra	-	-	-

## Combination wrenches Meccanocar



- Crom-vanadium steel.
- According to DIN 3113-A.
- New finish "Satin Finish".
- With drive-profil profile for a secure grip of the screw head.

Code	Descr. section mm	Length mm	Weight gr.
4200011006	11-6	100	13,5
4200011007	11-7	110	17,5
4200011008	11-8	120	21,5
4200011009	11-9	130	32
4200011010	11-10	140	36,5
4200011011	11-11	150	43
4200011012	11-12	160	52,8
4200011013	11-13	170	65
4200011014	11-14	180	76
4200011015	11-15	190	90
4200011016	11-16	200	102,5
4200011017	11-17	210	125,5
4200011018	11-18	220	146,6
4200011019	11-19	230	170
4200011020	11-20	240	187,2
4200011021	11-21	250	205
4200011022	11-22	260	220
4200011023	11-23	270	289
4200011024	11-24	280	299
4200011025	11-25	290	325
4200011026	11-26	300	330
4200011027	11-27	310	365
4200011028	11-28	320	436
4200011029	11-29	330	436
4200011030	11-30	340	484
4200011032	11-32	360	524
4200011034	11-34	380	640
4200011036	11-36	400	980
4200011038	11-38	400	1010
4200011041	11-41	440	1020
4200011046	11-46	490	1620
4200011050	11-50	530	2180



## Series combination wrenches



- In cardboard box.

Code	Desc.	N. Pieces	Measure mm
4200011622	11/12	12	6.7.8.9.10.11.12.13.14.17.19.22
4200011632	11/25	25	6.7.8.9.10.11.12.13.14.15.16.17. 18.19.20.21.22.23.24.25.26.27. 28.30.32.

## Fixed wrenches two mouths Meccanocar

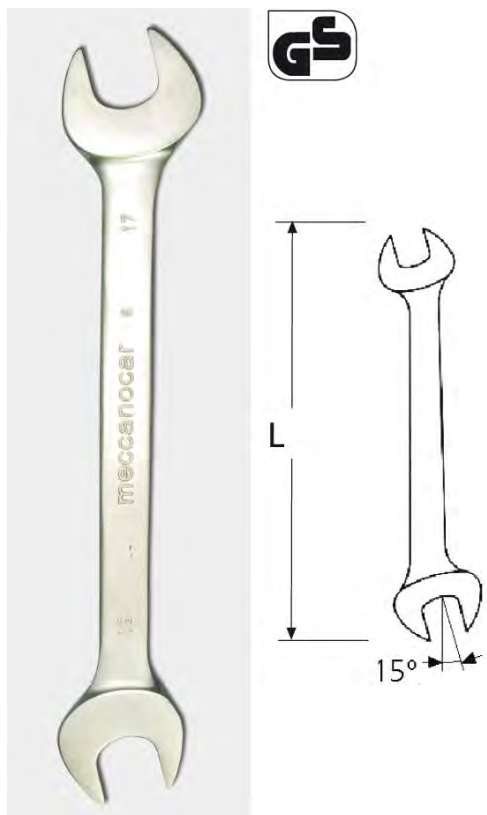

- According to DIN 3110.
- New finish "Satin Finish".

Code	Desc. measure mm	Length mm	Weight gr.
4200060607	6-6X7	122	19,5
4200060809	6-8X9	140	31
4200061011	6-10X11	156	49,8
4200061213	6-12X13	172	71
4200061415	6-14X15	190	88,5
4200061617	6-16X17	204	132
4200061819	6-18X19	223	165
4200062022	6-20X22	236	207
4200062426	6-24X26	265	345
4200062427	6-24X27	265	336
4200062528	6-25X28	280	370
4200063032	6-30x32	302	477
4200063034	6-30x34	302	547
4200063236	6-32x36	325	520
4200063641	6-36x41	358	870

8

## Series fixed wrenches two mouths



- In cardboard box.

Code	Desc.	N. Pieces	Measure mm
4200066722	6/8	8	6X7 - 8X9 - 10X11 - 12X13 - 14X15 - 16X17 - 18X19 - 20X22
4200066732	6/12	12	6X7 - 8X9 - 10X11 - 12X13 - 14X15 - 16X17 - 18X19 - 20X22 - 21X23 - 24X26 - 25X28 - 30X32

## Ring wrenches Meccanocar

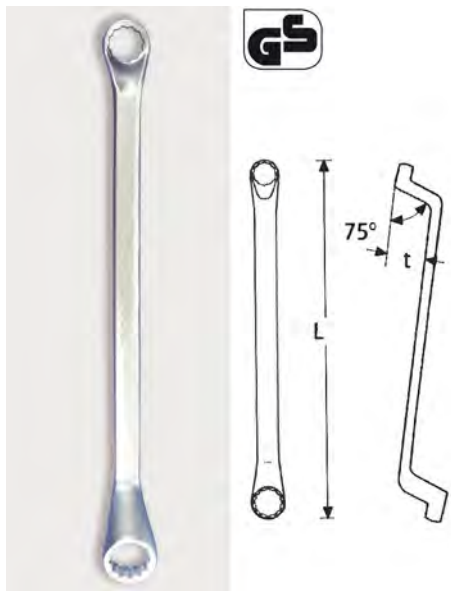

- According to DIN 838.
- New finish "Satin Finish".

Code	Desc. / Meas. mm	Length mm	Weight gr.
4200020607	2-6X7	180	43,5
4200020809	2-8X9	195	57
4200021011	2-10X11	205	76
4200021213	2-12X13	225	103,5
4200021415	2-14X15	235	150
4200021617	2-16X17	255	195
4200021819	2-18X19	275	239
4200022022	2-20X22	300	313,7
4200022123	2-21X23	315	345
4200022426	2-24X26	335	630
4200022427	2-24X27	335	467,5
4200022528	2-25X28	335	487,5
4200023032	2-30X32	365	618

## Series ring wrenches



- In cardboard box.

Code	Desc.	N. Pieces	Measure mm
4200026722	2/8	8	- 6X7 - 8X9 - 10X11 - 12X13 - 14X15 - 16X17 - 18X19 - 20X22
4200026732	2/12	12	- 6X7 - 8X9 - 10X11 - 12X13 - 14X15 - 16X17 - 18X19 - 20X22 - 21X23 - 24X26 - 25X28 - 30X32

## Support for combination wrenches



- Support indicated for combination wrenches.
- In plastic material.
- It allows the containment of 12 keys.
- For keys from the mis.6 mis.22.
- With closing system.
- Suitable for wall mounting or for inclusion in toolbox.

Code	Desc.	Capacity
3980004000	COVT12	Combination wrenches 6 to 22





## Support for ring wrenches



- In plastic material.
- It allows the containment of 8 keys.
- To the extent keys 6 x7 to measure 20x22.
- With closing system.
- Suitable for wall mounting or for inclusion in toolbox.

Code	Desc.	Capacity
3980004100	RGVT8	Ring wrenches from 6x7 to 20x22

## Support for combination wrenches and fixed



- In plastic material.
- It allows the containment of 12 keys.
- For keys from size 6 to 22 measure.
- With closing system.
- Suitable for wall mounting or for inclusion in toolbox.

Code	Desc.	Capacity
3980004200	VIP 333/12x6	Combination wrenches 6 to 22

8

## Ratchet combination



- Screwing strength in accordance with DIN 899 and higher as robustness to DIN 3110.
- Gear 72 teeth for a greater precision of movement.
- Ability to work on corners of only 5 °.
- For professional use and intense.

Code	Desc. / Meas. mm	A mm	L mm	Weight gr.
4430050100	990-8	17	140	27
4430050110	990-9	18,5	149	36
4430050120	990-10	20,5	160	46
4430050130	990-11	21,5	165	64
4430050140	990-12	23	170	75
4430050150	990-13	25	180	96
4430050160	990-14	28	190	106
4430050170	990-15	29	200	126
4430050180	990-16	30	210	164
4430050190	990-17	31,5	225	180
4430050200	990-18	33	235	206
4430050210	990-19	34	250	316
4430050215	990-22	41,5	290	322
4430050220	990-24	48	333	477
4430050230	990-27	52,5	360	616
4430050240	990-30	59	400	798
4430050250	990-32	62,5	425	958

## Reversible ratchet combination



- Screwing strength in accordance with DIN 899 and higher as robustness to DIN 3110.
- Gear 72 teeth for a greater precision of movement.
- Ability to work on corners of only 5 °.
- For professional use and intense.
- Be reversed by moving the switch located on the head Extra flat key.
- With stop ring cap that allows the key does not slip on the nut.

Code	Desc. / Meas. mm	A mm	B mm	C mm	L mm	Weight gr.
4430050270	991-8	16,8	6,5	16	140	28
4430050280	991-10	20,1	7,5	21	159	45
4430050290	991-13	25,1	8,5	27	180	74
4430050300	991-17	31,8	10,5	36	225	150
4430050310	991-19	34,1	11,5	40	248	204

## Assortment reversible ratchet wrenches in box



- 6 keys.

Code	Desc.	Content
4430050320	991/5 KIT	1 Pcs. 8 ; 10 ; 12 ; 13 ; 17 ; 19

## Ratchet wrenches swivel mount



- Screwing strength in accordance with DIN 899 and higher as robustness to DIN 3110.
- Gear 72 teeth for a greater precision of movement.
- Ability to work on corners of only 5 °.
- For professional use and intense.
- A swivel head 180 °.

Code	Desc. / Meas. mm	Length mm	A mm	Weight gr.
4430050330	992-8	140	17	32
4430050340	992-10	158	20	55
4430050344	992-11	165	22	76
4430050346	992-12	171	23	90
4430050350	992-13	176	25	114
4430050355	992-14	190	27,5	150
4430050360	992-15	199	29	150
4430050365	992-16	208	30	200
4430050370	992-17	225	32	210
4430050375	992-18	236	34	270
4430050380	992-19	248	34,3	375

## Adapters for keys



- Practical adapters with hexagonal Allen key or suitable for any polygon that let you turn a key in a ratchet for sockets or in a port bits.
- A model wears browned bits Hex attack. mm. 10 - 1/4.
- Three models with chrome head ultra flat and quick release device for sockets.

Code	Desc.	Attachment mm	Attachment	Length mm	For keys
4430050410	993KIT - 10 - 1/4 + 10 - 1/4 ES	10	Square 1/4 - 1/4 Hexagonal (are 2 pcs.)	20	M10
4430050420	993-13 -3/8	13	Square 3/8	25	M13
4430050430	993-19-1/2	19	Square 1/2	30	M19

## Spanners two mouths for Torx screws



- Chrome vanadium chrome plated.

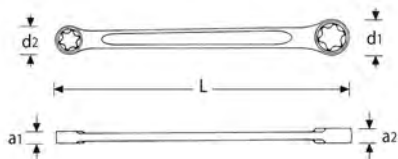

Code	Desc gr.	L mm	d1 mm.	d2 mm	a1 mm	a2 mm
4430045806	611 - E6xE8	115,5	9,6	11,6	4,5	5,5
4430045808	611 - E10xE12	149,5	13,7	15,7	6,5	7,5
4430045810	611 - E14xE18	185	17,8	22,5	8	9,5
4430045812	611 - E20xE24	227	24,7	29,2	10,5	12,5

## Series ring wrenches two mouths for Torx screws

Code	Description
4430045820	612 - SERIES 4 KEYS

## Keys for fittings hexagonal polygonal

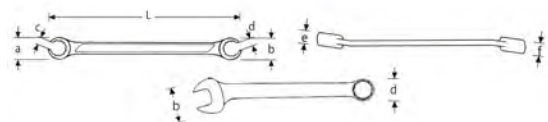

- Heads bent by 15° and inclined laterally by 15°.
- Hexagonal profile up to size from 12x14 mm; polygon for the above \*.
- Chrome vanadium steel.
- Chrome plated polished heads.
- Indicate on brake systems, power steering and hydraulic circuits, diesel injectors or turbocharging, compressed air systems and fittings in general.
- DIN 3118.
- With stationary for a practical support on the nut during the maneuver.
- Only measures hexagonal.

Code	Desc. Ø mm	a mm	b mm	c mm	d mm	e mm	f mm	L mm
4430045645	603 - 8x10	17	20	6	7	6,5	8	124
4430045647	603 - 10x11	20	22	7	8,5	8	8,5	124
4430045649	603 - 11x13	22	25,6	8,5	10	8,5	9,5	143
4430045651	603 - 12x14	23	26,6	9	11	9	10,5	143
4430045653	603 - 17x19 *	30	32	14	15	11	13	210
4430045655	603 - 19x22 *	32	38	15	17	13	15	220

## Ring spanners curves

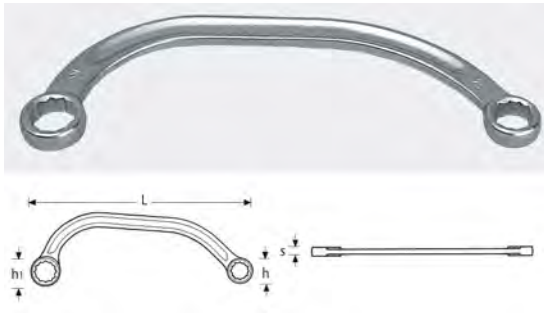

- ISO 3318.
- Chrome vanadium steel.
- Chrome plated polished head.
- Able to operate on generators, manifolds, starter motors.

Code	Desc. Ø mm	L mm	h mm	h1 mm	s mm
4430045686	607 - 10x12	143	17,0	19,5	8
4430045688	607 - 11x13	143	17,0	19,5	8
4430045690	607 - 14x17	184	22,5	24,5	9
4430045692	607 - 19x22	235	28,5	32,5	11

## Cross wrenches with hexagonal openings



- Keys in chrome vanadium steel with chrome plated.
- Designed to work on nuts of vehicles of all brands.
- The effort necessary work is guaranteed with the maximum sealing thanks to an appropriate procedure of electrofusion.
- UNI 6788.

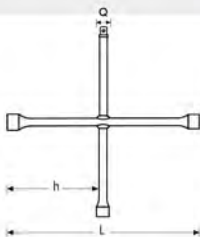

Code	Desc.	Ø mm	L mm	h mm
4430016900	265	17-19-23- Q 1/2"	372	178
4430016920	267	24-27-32- Q 3/4"	700	339

## Key "T" for removing double truck wheels

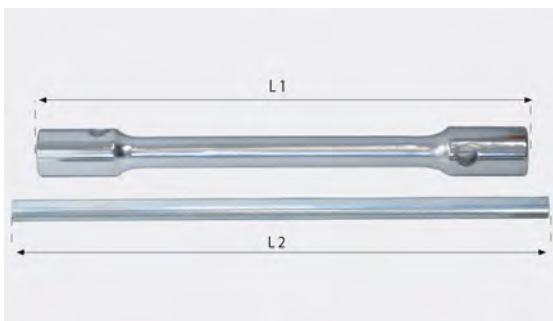

- Ideal as board equipment for industrial vehicles.
- Mouths hexagonal reinforced design efforts for maximum work.

Code	Desc. Ø mm	L1 mm	L2 mm
4430046054	648 - 27x30	390	400
4430046056	648 - 27x32	407	400
4430046057	648 - 30x32	400	400



### Series keys multisocket Meccanocar reversible ratchet



- Practical case of keys Meccanocar with reversible ratchet and profile strip.
- Product suitable for workshops cars, motorcycles and industrial vehicles, bodywork, elettrauto, installers HI FI, campers, airports, marine workshops, hauliers and earthmoving in general.
- Set of wrenches chrome vanadium extremely resistant, with profile multisocket fits screws with hexagonal profile, polygonal, Torx inch male depending on the measures.
- The special ductility and strength of the profiles allows to have a multi-purpose tool that can operate even in areas of poor accessibility, ie tighten a nut without having a clear view and angle.
- Ratchet teeth 72 for accurate movements and minimum angle.
- Be reversed by moving the switch located on the head of the key.
- Models with satin finish.
- The case includes 8 keys (8-10-11-12-13-14-17- 19 mm).



Code	Desc.
4200000560	826

8

### Key multi grip Meccanocar with reversible ratchet



- Combination wrenches multi grip Meccanocar with reversible ratchet.
- Tools chrome vanadium.
- Same characteristics as described above.

Code	Description	Metric (mm)	Inch (in)	Torx	Length mm
4200000390	8- COMBINATION WRENCH RATCHET REVERSIBLE.	8	5/16"	E10	139
4200000392	10- COMBINATION WRENCH RATCHET REVERSIBLE.	10	3/8"	E12	149
4200000394	11- COMBINATION WRENCH RATCHET REVERSIBLE.	11	7/16"	E14	164
4200000396	12- COMBINATION WRENCH RATCHET REVERSIBLE.	12	15/32"	-	170
4200000398	13- COMBINATION WRENCH RATCHET REVERSIBLE.	13	1/2"	E16	178
4200000400	14- COMBINATION WRENCH RATCHET REVERSIBLE.	14	9/16"	E18	188
4200000402	15- COMBINATION WRENCH RATCHET REVERSIBLE.	15	19/32"	-	198
4200000404	16- COMBINATION WRENCH RATCHET REVERSIBLE.	16	5/8"	E20	208
4200000406	17- COMBINATION WRENCH RATCHET REVERSIBLE.	17	21/32"	-	222
4200000408	19- COMBINATION WRENCH RATCHET REVERSIBLE.	19	3/4"	E24	235



## Keys strip ratchet Meccanocar articulated head



- Combination wrenches with reversible ratchet strip Meccanocar and jointed head.
- Tools chrome vanadium.
- Ratchet teeth 72 for accurate movements and minimum angle.
- Working capacity of angles of 5 ° and a swivel head up to 180 °.
- Profile strip that fits screws with hexagonal profile, polygonal, Torx inch male depending on the measures.

Code	Description	Metric (mm)	Inch (in)	Torx	Length mm
4200000430	8 - Combination wrenches reversible ratchet head joint	8	5/16"	E10	141
4200000432	10 - 8 - Combination wrenches reversible ratchet head joint	10	3/8"	E12	164
4200000434	11 - 8 - Combination wrenches reversible ratchet head joint	11	7/16"	E14	167
4200000436	12 - 8 - Combination wrenches reversible ratchet head joint	12	15/32"	-	173
4200000438	13 - 8 - Combination wrenches reversible ratchet head joint	13	1/2"	E16	182
4200000440	14 - 8 - Combination wrenches reversible ratchet head joint	14	9/16"	E18	194
4200000442	15 - 8 - Combination wrenches reversible ratchet head joint	15	19/32"	-	203
4200000444	16 - 8 - Combination wrenches reversible ratchet head joint	16	5/8"	E20	213
4200000446	17 - 8 - Combination wrenches reversible ratchet head joint	17	21/32"	-	227
4200000448	18 - 8 - Combination wrenches reversible ratchet head joint	18	11/16"	E22	235
4200000450	19 - 8 - Combination wrenches reversible ratchet head joint	19	3/4"	E24	249

## Combination wrenches strip Meccanocar



- Combination wrenches strip Meccanocar straight.
- Tools chrome vanadium.
- Same characteristics as described above.

Code	Description	Metric (mm)	Inch (in)	Torx	Length mm
4200000460	8 - KEY MULTIPLUG	8	5/16"	E10	125
4200000462	10 - KEY MULTIPLUG	10	3/8"	E12	145
4200000464	11 - KEY MULTIPLUG	11	7/16"	E14	155
4200000466	12 - KEY MULTIPLUG	12	15/32"	-	165
4200000468	13 - KEY MULTIPLUG	13	1/2"	E16	175
4200000470	14 - KEY MULTIPLUG	14	9/16"	E18	185
4200000472	17 - KEY MULTIPLUG	17	21/32"	-	215
4200000474	19 - KEY MULTIPLUG	19	3/4"	E24	235

## Spanners and wrenches crown

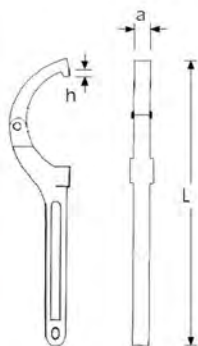

- Adjustable wrenches in the industry for nuts (lug nuts).
- Suitable for car and motorcycle workshops.
- The particular structure of the model allows it to act with a single key on a wide range of measures of the dice.
- Sturdy construction made of chrome vanadium steel, profile designed for optimum grip.
- Capacity from 15 mm to 180 mm.

Code	Desc. Ø mm	a mm	h mm	L mm
4430045990	623 - 15-35	5	3	168
4430045992	623 - 35-50	6	4	202
4430045994	623 - 50-80	8	5	280
4430045996	623 - 80-120	9	5,5	345
4430045998	623 - 120-180	11,2	9	495

## Allen keys

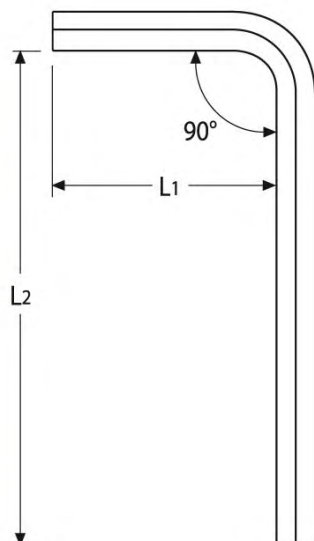
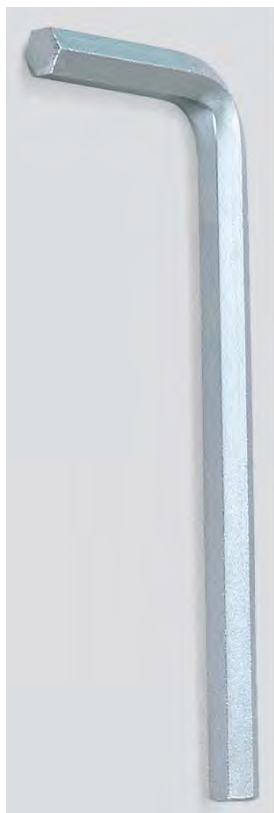

- DIN 911.
- For Allen screws.
- Made of chrome-vanadium.
- Chrome galvanized.

Code	Desc. Ø mm	L1 mm	L2 mm
4430012900	226 - 2,0	16	55
4430012910	226 - 2,5	18	60
4430012920	226 - 3	20	65
4430012940	226 - 4	25	72
4430012950	226 - 4,5	28	80
4430012960	226 - 5	28	80
4430012970	226 - 5,5	32	90
4430012980	226 - 6	32	90
4430012990	226 - 7	34	95
4430013000	226 - 8	36	100
4430013010	226 - 9	38	105
4430013020	226 - 10	40	112
4430013040	226 - 12	45	125
4430013050	226 - 14	55	140
4430013060	226 - 17	60	160
4430013070	226 - 19	70	175
4430013080	226 - 22	80	200

## Series Allen keys with plastic support 9 pieces



- Chrome-vanadium running burnished.
- DIN 911.

Code	Description	Content
4430013100	227 - SERIES 9 PIECES	1,5-2-2,5-3-4-5-6-8-10

## Series Allen keys with support ring 9 pcs.



- Chrome-vanadium running burnished.
- DIN 911.

Code	Description	Content (mm)
4430013200	228 - SERIES 9 PIECES	1,5 - 2 - 2,5 - 3 - 4 - 5 - 6 - 8-10

## Series Allen keys with metal pieces 7



- Chrome-vanadium running burnished.
- DIN 911.

Code	Description	Content (mm)
4430026700	333 - SERIES 7 PIECES	2,5; 3; 4; 5; 6; 8; 10

## Allen wrenches Allen spherical head



- Keys with spherical head in the long part.
- The ball head allows you to work with an inclination angle up to 25°.
- The use of the spherical head allows a rapidity of use and convenience of use.
- The surface treatment of black finish of the key gives a very good corrosion resistance.
- Keys made of special steel resistant to efforts also due to screws oxidized, damaged or lockouts excess.
- To loosen and tighten all types of screw head with hexagon socket (Allen).

Code	Desc. <i>Measure</i>	Lunghezza L1+L2 interno
4430056415	1763-1,5	14-77
4430056420	1763-2	16-82
4430056425	1763-2,5	17-88
4430056430	1763-3	19-98
4430056440	1763-4	22-110
4430056450	1763-5	27-119
4430056460	1763-6	31-139
4430056480	1763-8	35-162
4430056500	1763-10	39-187
4430056520	1763-12	44-220

8

## Set of Allen wrenches Allen spherical head



- On plastic holder
- Convenient range from 1.5 to 10mm.
- Keys made of special steel resistant to efforts also due to screws oxidized, damaged or lockouts excess.

Code	Desc.	Content 1piece X size
4430045425	585	1,5-2-2,5-3-4-5-6-8-10

## Series keys each XZN with metal 5 pieces



- Chrome-vanadium chrome plated.

Code	Description	Content (mm)
4430026600	332 - SERIES 5 PIECES	M 5; 6; 8; 10; 12

## Series Torx keys with plastic support



- Chrome-vanadium - running black.

Code	Description	Content
4770000510	51 - SERIES 8 PCS	T9; T10; T15; T20; T25; T27; T30; T40

## Torx keys each with spherical head



- Made of chrome-vanadium, burnished execution.
- For recessed Torx screws with tilt angle up to 25 °.

Code	Desc gr.	L mm
4430045900	618 - T 9	50
4430045902	618 - T 10	80
4430045904	618 - T 15	85
4430045906	618 - T 20	95
4430045908	618 - T 25	100
4430045910	618 - T 27	105
4430045912	618 - T 30	115
4430045914	618 - T 40	125
4430045916	618 - T 45	135
4430045918	618 - T 50	145
4430045920	618 - T 55	170

## Series Torx keys spheroidal



- Chrome-vanadium running black.
- The special processing of the wrench head enables working in places of difficult access.
- It can be tilted by 25 °.

Code	Description	Content
4770000960	96-8 PCS	8 PZ.: T15; T20; T25; T27; T30; T40; T45; T50



## Hexagonal sockets Short 1/4" Q. 6.35 mm



Code	Desc.	Measure mm	Diameter E mm	Length mm
4200000110	414-4C	4	12	25
4200000112	414-4,5C	4,5	12	25
4200000114	414-5C	5	12	25
4200000116	414-5,5C	5,5	12	25
4200000118	414-6C	6	12	25
4200000120	414-7C	7	12	25
4200000122	414-8C	8	12	25
4200000124	414-9C	9	13	25
4200000126	414-10C	10	14	25
4200000128	414-11C	11	16	25
4200000130	414-12C	12	17	25
4200000132	414-13C	13	18	25
4200000134	414-14C	14	20	25

- Profile "drive-profil" for a secure grip of the screw head.
- Finish "Satin-Finish".

## Hexagonal sockets Long 1/4" Q. 6.35 mm



- Profile "drive-profil" for a secure grip of the screw head.
- Finish "Satin-Finish".

Code	Desc.	Measure mm	Diameter E mm	Length mm
4200000140	414-6L	6	12	50
4200000142	414-7L	7	12	50
4200000144	414-8L	8	12	50
4200000146	414-9L	9	13	50
4200000148	414-10L	10	14	50
4200000150	414-11L	11	16	50
4200000152	414-12L	12	17	50
4200000154	414-13L	13	18	50
4200000156	414-14L	14	20	50

## Bushings polygonal court 1/4" Q. 6.35 mm

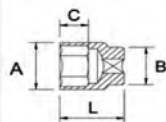

Code	Desc. Measures	Length L mm	Ø est. A mm	Ø est. attacco B mm	Mouth depth C mm
4200098804	5C	24	9	11	5
4200098805	5,5C	24	9	11	5
4200098806	6C	24	10	11	5
4200098807	7C	24	11	11	5
4200098808	8C	24	12	11	8
4200098809	9C	24	14	11	8
4200098810	10C	24	14	12	8
4200098811	11C	24	16	13	8
4200098812	12C	24	17	14	8
4200098813	13C	24	18	16	10
4200098814	14C	24	20	18	10

- Polygonal profile.
- Satin finish.
- Chromium steel-vanadium.
- To DIN 3124 standards.

## Bushings polygonal long 1/4" Q. 6.35 mm

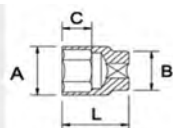

Code	Desc. <i>Measures</i>	Length <i>L mm</i>	Ø est. <i>A mm</i>	Ø est. attacco <i>B mm</i>	Mouth depth <i>C mm</i>
4200098824	5L	48	9	9	8
4200098825	5,5L	48	10	10	8
4200098826	6L	48	11	11	10
4200098827	7L	48	12	12	10
4200098828	8L	48	12	12	10
4200098829	9L	48	14	14	10
4200098830	10L	48	15	15	12
4200098831	11L	48	17	17	12
4200098832	12L	48	17	17	12
4200098833	13L	48	18	18	12
4200098834	14L	48	20	20	12

- Chromium-vanadium steel.
- To DIN 3124 standards.

## Bushings profile PH connection 1/4 "Q. 6.35 mm



- Chromium-vanadium steel.

Code	Desc. <i>Measures</i>	Length <i>L mm</i>
4200098841	PH1	37
4200098842	PH2	37
4200098843	PH3	37

## Bushings profile PCS connection 1/4 "Q. 6.35 mm



- Chromium-vanadium steel.

Code	Desc. <i>Measures</i>	Length <i>L mm</i>
4200098851	PZ1	37
4200098852	PZ2	37
4200098853	PZ3	37

## Bushings with hexagonal profile male 1/4 "Q. 6.35 mm



- Made of chrome-vanadium.

Code	Desc. <i>Measures</i>	Length <i>L mm</i>
4200098863	3ES	37
4200098864	4ES	37
4200098865	5ES	37
4200098866	6ES	37
4200098868	8ES	37

## Bushings Torx male connection 1/4 "Q. 6.35 mm



- Chromium-vanadium steel.

Code	Desc. <i>Measure</i>	Length <i>L mm</i>
4200098870	37	T8
4200098872	37	T9
4200098874	37	T10
4200098876	37	T15
4200098878	37	T20
4200098880	37	T25
4200098882	37	T27
4200098884	37	T30
4200098886	37	T40

8

## Accessories for sockets 1/4 "Q. 6.35 mm



- Extension 1/4 ".
- Finish "Satin-Finish".

Code	Desc.	Leng. <i>mm</i>	Diameter E mm
4200000160	414P-75	75	12,5
4200000162	414P-150	150	12,5

## Cardanic joint 1/4 "Q. 6.35 mm



- Finish "Satin-Finish".

Code	Desc.	Leng. <i>mm</i>	Diameter E mm
4200000164	414S	40	14

## Socket tray 1/4 "Q. 6.35 mm



- Finish "Satin-Finish".

Code	Desc.	Leng. <i>mm</i>
4200000166	414PB	150

## Adapter 1/4 -1/4 "Q. 6.35 mm



- It allows you to use the hex bits 1/4 with various accessories for compasses square drive 1/4 ".

Code	Desc.	Leng. mm
4200000168	414AD	25

## Adapters for sockets and accessories



- Finish "Satin-Finish".

Code	Desc.	Female panel	Male panel
4200001438	1/4F-3/8M	1/4	3/8

## Rod with slide for sockets 1/4 "Q. 6.35 mm



- Complies with din 3122 standards.
- Chrome-vanadium.

Code	Desc.	Length L mm
4200000170	414A	115

## Reversible ratchet 72d-1/4" Q. 6.35 mm



- Finish "Satin-Finish".
- The ergonomic shape allows the use even in tight spaces and 72 teeth allow a turning angle of just 5 °.
- With safety button for the release of bushings or accessories to prevent accidental fall.
- Maximum reliability and maneuverability.

Code	Desc.	Leng. mm
4200000105	414C	140

## Kit bushes Meccanocar 1/4 "



- Bushings made of chrome vanadium.
- Finish "Satin Finish".
- All kits supplied in metal case.

Code	Description
420000100	414 kit hexagonal sockets 1/4 "

CONTENUTO	
420 00 00105	414c-1/4" CRICCO REV.72 DENTI
n° 13	BUSSOLE ESAG - CORTE: M4-4,5-5-5,5-6-7-8-9-10-11-12-13-14
n° 9	BUSSOLE ESAG - LUNGHE: M6-7-8-9-10-11-12-13-14
n° 2	PROLUNGHE mm 75-150
n° 1	SNODO CARDANICO
n° 1	IMPUGNATURA
420 00 00167	33 BITS 1/4" + PORTA BITS

## Deposit bushings multisocket Meccanocar 1/4 "



- Practice safe deposit bushings multisocket 1/4 ".
- Product suitable for car and motorcycle repair shops, body shops, elettrauto, installers hi fi, campers, airports and maintenance.
- The kit includes a variety of accessories and bushings multisocket chrome vanadium extremely resistant.
- The profile multisocket fits screws with hexagonal profile, polygonal, in inches and Torx male.
- The particular ductility and strength of the sleeves allows to have a multipurpose instrument that allows to operate also in areas of poor accessibility
- The kit consists of 20 pieces all available individually.
- Do not use compasses with air guns.

Code	Desc.
4200000580	827

TABELLA RIEPILOGATIVA BUSSOLE MULTIPRESA 1/4"		
ESAGONO/METRICO (MM)	POLLICI (INCH)	TORX
3.2	1/8"	E4
4	5/32"	E5
4.5	-	-
5	3/16"	E6
5.5	7/32"	E7
6	-	E8
7	9/32"	-
8	5/16"	E10
9	11/32"	E11
10	3/8"	E12
11	7/16"	E14
12	15/32"	-
13	1/2"	E16
14	9/16"	E18

CONTENUTO KIT	
420 00 00105	414C-CRICCHETTO REVERS. 1/4"
420 00 00166	414PB - PORTA BUSSOLE 1/4"
420 00 00163	414P/50 - PROLUNGA 50 mm
420 00 00162	414P/150 - PROLUNGA 150 mm
420 00 00545	115 1/4 - MANICO FISSO 1/4" 115mm
420 00 00164	414S - SNODO CARDANICO 1/4"
420 00 00520	3.2 - BUSSOLA MULTIP. 1/4", 3.2mm
420 00 00522	4 - BUSSOLA MULTIP. 1/4", 4 mm
420 00 00523	4.5 BUSSOLA MULTIP. 1/4", 4.5mm
420 00 00524	5 - BUSSOLA MULTIP. 1/4", 5mm
420 00 00526	5.5 - BUSSOLA MULTIP. 1/4", 5.5mm
420 00 00528	6 - BUSSOLA MULTIP. 1/4", 6 mm
420 00 00530	7 - BUSSOLA MULTIP. 1/4", 7 mm
420 00 00532	8 - BUSSOLA MULTIP. 1/4", 8 mm
420 00 00534	9 - BUSSOLA MULTIP. 1/4", 9 mm
420 00 00536	10 - BUSSOLA MULTIP. 1/4", 10mm
420 00 00538	11 - BUSSOLA MULTIP. 1/4", 11 mm
420 00 00540	12 - BUSSOLA MULTIP. 1/4", 12 mm
420 00 00542	13 - BUSSOLA MULTIP. 1/4", 13mm
420 00 00544	14 - BUSSOLA MULTIP. 1/4", 14mm



## Hexagonal sockets Short 3/8" O. 10 mm



- Profile "Drive-Profil" for a secure grip of the screw head.
- Finish "Satin-Finish".

Code	Desc.	Measure mm	Diameter E mm	Length mm
4200000250	824-8C	8	17	28
4200000251	824-9C	9	17	28
4200000252	824-10C	10	17	28
4200000253	824-11C	11	17	28
4200000254	824-12C	12	17	28
4200000255	824-13C	13	18	28
4200000256	824-14C	14	20	28
4200000257	824-15C	15	22	28
4200000258	824-16C	16	22	28
4200000259	824-17C	17	24	28
4200000260	824-18C	18	26	30
4200000261	824-19C	19	26	30
4200000262	824-20C	20	28	30
4200000263	824-21C	21	28	30
4200000264	824-22C	22	30	30
4200000265	824-23C	23	32	30
4200000266	824-24C	24	32	30

## Hexagonal sockets Long 3/8" Q. 10 mm



- Profile "Drive-Profil" for a secure grip of the screw head.
- Finish "Satin-Finish".

Code	Desc.	Measure mm	Diameter E mm	Length mm
4200000270	824-8L	8	17	63
4200000271	824-9L	9	17	63
4200000272	824-10L	10	17	63
4200000273	824-11L	11	17	63
4200000274	824-12L	12	17	63
4200000275	824-13L	13	18	63
4200000276	824-14L	14	20	63
4200000277	824-15L	15	22	63
4200000278	824-16L	16	22	63
4200000279	824-17L	17	24	63
4200000280	824-18L	18	24	63
4200000281	824-19L	19	26	63

## Bushings polygonal court 3/8" Q. 10 mm

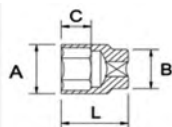

- Polygonal profile.
- Satin finish.
- Chromium steel-vanadium.
- To DIN 3124 standards.

Code	Desc. Measures	Length L mm	Ø est. A mm	Ø est. attacco B mm	Mouth depth C mm
4200098908	8C	27	13	17	12
4200098909	9C	27	14	17	12
4200098910	10C	27	15	17	12
4200098911	11C	27	16	17	12
4200098912	12C	27	16	17	12
4200098913	13C	27	18	17	12
4200098914	14C	27	20	18	14
4200098915	15C	27	22	20	14
4200098916	16C	27	23	20	14
4200098917	17C	29	24	21	16
4200098918	18C	29	26	22	16
4200098919	19C	29	26	22	16
4200098920	20C	31	28	24	18
4200098921	21C	31	28	24	18
4200098922	22C	31	30	26	18

## Bushings polygonal long 3/8 "Q. 10 mm

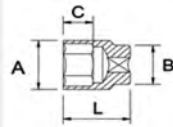

Code	Desc. Measures	Length L mm	Ø est. A mm	Ø est. attacco B mm	Mouth depth C mm
4200098937	7L	62	12	12	12
4200098938	8L	62	13	13	12
4200098939	9L	62	14	14	12
4200098940	10L	62	15	15	12
4200098941	11L	62	16	16	14
4200098942	12L	62	18	18	14
4200098943	13L	62	20	20	18
4200098944	14L	62	20	20	18
4200098945	15L	62	23	23	18
4200098947	17L	62	25	25	18
4200098948	18L	62	27	27	18
4200098949	19L	62	27	27	18
4200098950	20L	62	29	29	20
4200098952	22L	62	31	31	20

- Polygonal profile.
- Satin finish.
- Chromium steel-vanadium.
- To DIN 3124 standards.

## Bushings 3/8 "Hex profile. Q. male 10 mm



Code	Desc.	Measure mm	Length mm	Photo
4200000212	4-L48	4	48	1
4200000213	5-L48	5	48	1
4200000214	6-L48	6	48	1
4200000216	8-L48	8	48	1
4200000217	9-L48	9	48	1
4200000218	10-L48	10	48	1
4200000220	12-L48	12	48	1
4200000221	4-L140	4	140	2
4200000222	5-L140	5	140	2
4200000223	6-L140	6	140	2
4200000224	7-L140	7	140	2
4200000225	8-L140	8	140	2
4200000226	9-L140	9	140	2
4200000227	10-L140	10	140	2
4200000228	12-L140	12	140	2

- Finish "Satin-Finish".
- The bushings are used on all the screws with hexagon socket.

## Bushings 3/8 "with male profile Torx Q. 10 mm



Code	Desc.	Measure mm	Length mm	Photo
4200000232	T15-L48	T15	48	1
4200000233	T20-L48	T20	48	1
4200000234	T25-L48	T25	48	1
4200000235	T27-L48	T27	48	1
4200000236	T30-L48	T30	48	1
4200000237	T40-L48	T40	48	1
4200000238	T45-L48	T45	48	1
4200000239	T50-L48	T50	48	1
4200000241	T15-L140	T15	140	2
4200000242	T20-L140	T20	140	2
4200000243	T25-L140	T25	140	2
4200000244	T27-L140	T27	140	2
4200000245	T30-L140	T30	140	2
4200000246	T40-L140	T40	140	2
4200000247	T45-L140	T45	140	2
4200000248	T50-L140	T50	140	2

- Finish "Satin-Finish".
- The bushings are used on all screws with Torx female imprint.

## Rod with slide for sockets 3/8 Q. 10 mm



- To DIN 3122 standards.
- Made of chrome-vanadium.

Code	Desc.	Length L mm
4200000287	824A	165

## Accessories for sockets 3/8 "Q. 10 mm



- Extension 3/8".
- Finish "Satin-Finish".

Code	Desc.	Leng. mm	Diameter E mm
4200000284	824P-75	75	18
4200000285	824P-150	150	18

## Cardanic joint 3/8" Q. 10 mm



- Finish "Satin-Finish".

Code	Desc.	Leng. mm	Diameter E mm
4200000286	824S	55	18

## Adapters for sockets and accessories



- Finish "Satin-Finish".

Code	Desc.	Female panel	Male panel
4200003814	3/8F-1/4M	3/8	1/4
4200003812	3/8F-1/2M	3/8	1/2

## Reversible ratchet 72d-3/8" Q. 10 mm



- Finish "Satin-Finish".
- The ergonomic shape allows the use even in tight spaces and 72 teeth allow a turning angle of just 5°.
- With safety button for the release of bushings or accessories to prevent accidental fall.
- Maximum reliability and maneuverability.

Code	Desc.	Leng. mm
4200000205	824C	200

## Socket wrench spark plug 18 3/8" Q. 10



- With retaining spring.
- With external hexagon 21.

Code	Desc.	Attachment □
4770000640	64-18	3/8

## Bushings for candles from 14



Cod. 4200099440



Cod. 4200099450

- Bushings for candles M12x1,25.
- Bushings with joint for better maneuverability.
- With square 3/8 ".
- With grommet interior for retaining the spark plug during the extraction phase.
- Long and short version to be used depending on the placement of candles.
- M12x1,25 candles are mounted on petrol engines of the French cars.
- Polygonal profile.
- For workshops, garages, service stations.

Code	Description	Control panel attachment
4200099440	Bushings for candles -14C-145	3/8
4200099450	Bushings for candles -14L-275	3/8



## Handle with joint 3/8" Q. 10 mm



- Finish "Satin-Finish".
- Tool particularly useful for removing particular not be reached with normal tools.

Code	Desc.	Leng. mm
4200000288	824I	300



## Kit bushings 3/8 "



Code	Description
4200000200	824 kit hexagonal sockets 3/8"
4200000205	824C - 3/8 "ratchet teeth 72

COMPOSIZIONE KIT BUSSOLE 3/8"	
420 00 00205	824C - 3/8" cricco 72 denti
n° 17	BUSSOLE ESAGONALI NORMALI: M8,9,10,11,12,13,14,15,16,17,18,19,20,21,22,23,24
n° 12	BUSSOLE ESAGONALI LUNGHE: M8,9,10,11,12,13,14,15,16,17,18,19
n° 2	PROLUNGHE mm 75,150
n° 1	SNODO CARDANICO
n° 1	IMPUGNATURA CON SNODO

## Kit hexagonal sockets male 3/8"



Code	Description
4200000210	kit compasses m. hexagonal 3/8 "c + l

CONTENUTO	
n° 8	BUSSOLE ESAGONALI MASCHIO CORTE mm 48: M4,5,6,7,8,9,10,12
n° 8	BUSSOLE ESAGONALI MASCHIO LUNGHE mm 140: M4,5,6,7,8,9,10,12

## Kit bushes Torx male 3/8 "



Code	Description
4200000230	Kit bushes male Torx 3/8 "c + l

CONTENUTO	
n° 8	BUSSOLE TORX MASCHIO CORTE mm 48: T15,T20,T25,T27,T30,T40,T45,T50
n° 8	BUSSOLE TORX MASCHIO LUNGHE mm 140: T15,T20,T25,T27,T30,T40,T45,T50



## Hexagonal sockets Short 1/2 "Q. 12.5 mm



- Profile "Drive-Profil" for a secure grip of the screw head.
- Finish "Satin-Finish".

Code	Desc.	Measure mm	Diameter E mm	Length mm
4200000360	1032-10	10	22	38
4200000361	1032-11	11	22	38
4200000362	1032-12	12	22	38
4200000363	1032-13	13	22	38
4200000364	1032-14	14	22	38
4200000365	1032-15	15	22	38
4200000366	1032-16	16	22	38
4200000367	1032-17	17	24	38
4200000368	1032-18	18	26	38
4200000369	1032-19	19	26	38
4200000370	1032-20	20	28	38
4200000371	1032-21	21	28	38
4200000372	1032-22	22	30	38
4200000373	1032-23	23	32	38
4200000374	1032-24	24	32	38
4200000375	1032-27	27	36	42
4200000376	1032-30	30	40	42
4200000377	1032-32	32	42	42

## Hexagonal sockets Long 1/2" Q. 12.5 mm

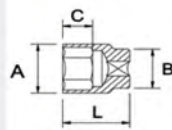

- Hexagonal profile.
- Satin finish.
- Chromium-vanadium steel.
- To DIN 3124 standards.

Code	Desc. Measure	Length L mm	Ø est. A mm	Ø est. attacco B mm	Mouth depth C mm
4200098960	10L	75	17	17	9
4200098961	11L	75	18	18	11
4200098962	12L	75	19	19	12
4200098963	13L	75	21	21	12
4200098964	14L	75	22	22	15
4200098965	15L	75	23	23	15
4200098966	16L	75	23	23	15
4200098967	17L	75	24	24	15
4200098968	18L	75	26	26	18
4200098969	19L	75	26	26	18
4200098971	21L	75	28	28	18
4200098972	22L	75	30	30	18
4200098973	23L	75	32	32	21
4200098974	24L	75	32	32	21
4200098976	26L	75	34	34	24
4200098977	27L	75	36	36	27
4200098978	28L	75	38	38	27
4200098979	29L	75	38	38	27
4200098980	30L	75	40	40	30
4200098982	32L	75	42	42	30

## Bushings polygonal court 1/2 " Q. 12.5 mm

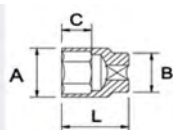

- Polygonal profile.
- Satin finish.
- Chromium steel-vanadium.
- To DIN 3124 standards.

Code	Desc. Measure	Length L mm	Ø est. A mm	Ø est. attacco B mm	Mouth depth C mm
4200098990	10C	40	16	21	6
4200098991	11C	40	17	21	7
4200098992	12C	40	18	21	8
4200098993	13C	40	19	21	8
4200098994	14C	40	21	21	10
4200098995	15C	40	22	21	10
4200098996	16C	40	22	21	10
4200098997	17C	40	24	22	10
4200098998	18C	40	26	23	12
4200098999	19C	40	26	23	12
4200099000	20C	40	28	26	12
4200099021	21C	40	28	26	12
4200099022	22C	40	30	31	14
4200099023	23C	40	32	31	14
4200099024	24C	40	32	31	16
4200099025	25C	44	34	31	16
4200099026	26C	44	34	31	16
4200099027	27C	44	36	34	18
4200099028	28C	45	38	34	20
4200099029	29C	45	38	34	20
4200099030	30C	45	40	34	20
4200099032	32C	45	42	38	22

## Bushings polygonal long 1/2 " Q. 12.5 mm

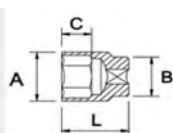

- Polygonal profile.
- Satin finish.
- Chromium steel-vanadium.
- To DIN 3124 standards.

Code	Desc. Measure	Length L mm	Ø est. A mm	Ø est. attacco B mm	Mouth depth C mm
4200099040	10L	75	17	17	9
4200099041	11L	75	18	18	11
4200099042	12L	75	19	19	12
4200099043	13L	75	21	21	12
4200099044	14L	75	22	22	15
4200099045	15L	75	23	23	15
4200099046	16L	75	23	23	15
4200099047	17L	75	24	24	15
4200099048	18L	75	26	26	18
4200099049	19L	75	26	26	18
4200099051	21L	75	28	28	18
4200099052	22L	75	30	30	18
4200099053	23L	75	32	32	21
4200099054	24L	75	32	32	24
4200099056	26L	75	34	34	24
4200099057	27L	75	36	36	27
4200099058	28L	75	38	38	27
4200099059	29L	75	38	38	27
4200099060	30L	75	40	40	30
4200099062	32L	75	42	42	30

## Bushings XZN short series 1/2 "Q. 12.5 mm



- XZN profile.
- Chromium steel-vanadium.

Code	Desc. Measure	Leng. mm
4200099075	M5 C-XZN	55
4200099076	M6C-XZN	55
4200099078	M8C-XZN	55
4200099080	M10C-XZN	55
4200099082	M12C-XZN	55
4200099084	M14C-XZN	55

## Bushings XZN long series 1/2 " Q. 12.5 mm



- XZN profile.
- Chromium-vanadium steel.

Code	Desc. Measure	Leng. mm
4200099096	M6L-XZN	100
4200099098	M8L-XZN	100
4200099100	M10L-XZN	100
4200099102	M12L-XZN	100

8

## Bushings ribe long series 1/2" Q. 12.5 mm



- Ribe profile.
- Chrome-vanadium steel.

Code	Desc. Measure	Leng. mm
4200099105	M5	100
4200099106	M6	100
4200099107	M7	100
4200099108	M8	100
4200099109	M9	100
4200099110	M10	100
4200099112	M12	100

## Bushings 1/2 "with male hexagon profile Q. 12.5 mm



Code	Desc.	Measure mm	Length mm	Photo
4200000312	5-L55	5	55	1
4200000313	6-L55	6	55	1
4200000314	7-L55	7	55	1
4200000315	8-L55	8	55	1
4200000316	9-L55	9	55	1
4200000317	10-L55	10	55	1
4200000318	12-L55	12	55	1
4200000319	14-L55	14	55	1
4200000320	17-L55	17	55	1
4200000321	19-L55	19	55	1
4200000323	5-L140	5	140	2
4200000324	6-L140	6	140	2
4200000325	7-L140	7	140	2
4200000326	8-L140	8	140	2
4200000327	10-L140	10	140	2
4200000328	12-L140	12	140	2

- Finish "Satin-Finish".
- The bushings are used on all the screws with hexagon socket.

## Bushings 1/2 "with male profile Torx Q.12,5 mm



Code	Desc.	Measure mm	Length mm	Photo
4200000332	T15-L55	T15	55	1
4200000333	T20-L55	T20	55	1
4200000334	T25-L55	T25	55	1
4200000335	T27-L55	T27	55	1
4200000336	T30-L55	T30	55	1
4200000337	T40-L55	T40	55	1
4200000338	T45-L55	T45	55	1
4200000339	T50-L55	T50	55	1
4200000340	T55-L55	T55	55	1
4200000341	T60-L55	T60	55	1
4200000343	T15-L140	T15	140	2
4200000344	T20-L140	T20	140	2
4200000345	T25-L140	T25	140	2
4200000346	T27-L140	T27	140	2
4200000347	T30-L140	T30	140	2
4200000348	T40-L140	T40	140	2
4200000349	T45-L140	T45	140	2
4200000350	T50-L140	T50	140	2
4200000351	T55-L140	T55	140	2
4200000352	T60-L140	T60	140	2

- Finish "Satin-Finish".
- The bushings are used on all screws with Torx female imprint.

## Bushing screw heads Toyota cars



- Bussola con attacco 1/2".
- Profilo xzn mis. 9.
- Indispensabile per le viti delle teste.

Code	Desc.	Attachment
4770002850	285-9x100-XZN	1/2"

## Bushings profile Ribe



- Ribe profile.
- 1/2 ".
- Chrome plated finish with burnished insert.
- Chrome steel-vanadium.

Code	Desc.	Applications
4430045151	546 - 7 L100	COVER VALVES: FIAT, LANCIA
4430045152	546 - 8 L140	BELL GEAR: FIAT GROUP
4430045154	546 - 9 L63	BOLTS CYLINDER HEAD ENGINES 1,200 16V: FIAT; LANCIA INJECTION PUMP. DIESEL: LANCIA
4430045153	546 - 10 L100	VARIOUS APPLICATIONS: FIAT GROUP
4430047484	791 - 12 L63	CYLINDER HEAD BOLTS ENGINE. PETROL: TYPE; DEDRA ECC.
4430045158	546 - 13 L100	BOLTS CYLINDER HEAD LANCIA; FIAT; DEDRA

8

## Bushing Torx profile



- Profile Torx male.
- 1/2 ".
- Satin finish.
- Chrome steel-vanadium.

Code	Desc.	Measures	Applications
4430047476	790	T 70L	CYLINDER HEAD BOLTS: FORD

## Bushing profile XZN



- Profile XZN male.
- 1/2 ".
- Satin finish.
- Chrome steel-vanadium.

Code	Desc.	Measures	Applications
4770001970	197	14 x 100	CYLINDER HEAD BOLTS ENGINE 164 VM



## Wrenches Torx female 1/2 "



- Applications: OPEL; RENAULT, AUDI V6; OPEL 16V

Code	Desc.	L mm
4430047560	795 - E 10	77
4430047562	795 - E 12	77
4430047564	795 - E 14	77
4430047566	795 - E 16	77
4430047568	795 - E 18	77
4430047570	795 - E 20	77

## Bushings for candles 1/2" Q. 12.5 mm



- With gasket for retaining the spark plug.
- With external hex maneuvering over the square connection.

Code	Desc. Measure	External hexagon mm
4200000515	16C	21
4200000516	21C	24

## Accessories for sockets 1/2 "Q. 12.5 mm



- Extensions 1/2 ".
- Finish "Satin-Finish".

Code	Desc.	Leng. mm	Diameter E mm
4200000379	1032P-75	75	-
4200000380	1032P-125	125	24
4200000382	1032P-250	250	24

## Cardanic joint 1/2 "Q. 12.5 mm



- Finish "Satin-Finish".

Code	Desc.	Leng. mm	Diameter E mm
4200000384	1032S	70	25

## Adapters for sockets and accessories



- Finish "Satin-Finish".

Code	Desc.	Female panel	Male panel
4200001238	1/2F-3/8M	1/2	3/8
4200001234	1/2F-3/4M	1/2	3/4

## Fixed handles

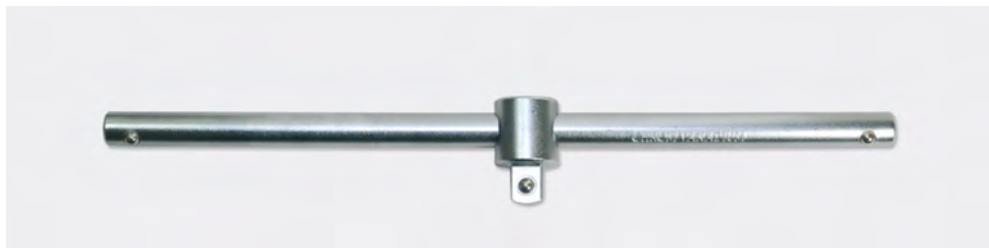

- Handle with handle sliding T for the use of bushes directly or through an extension cord.
- Manufactured in chrome vanadium steel for maximum strength.
- Available in two different lengths: 250 and 300 mm.

Code	Description
4200000517	250 - HANDLE 1/2" LENGTH 250
4200000518	300 - HANDLE 1/2" LENGTH 300

## Reversible ratchet 72d-1/2 "Q. 12.5 mm



- Finish "Satin-Finish".
- The ergonomic shape allows the use even in tight spaces and 72 teeth allow a turning angle of just 5°.
- With safety button for the release of bushings or accessories to prevent accidental fall.
- Maximum reliability and maneuverability.

Code	Desc.	Leng. mm
4200000305	1032C	245

8

## Handle with joint 1/2 "Q. 12.5 mm



- Finish "Satin-Finish".
- Tool particularly useful for removing particular not be reached with normal tools.

Code	Desc.	Leng. mm
4200000386	1032I	300

## Adapters for sockets and accessories



- Finish "Satin-Finish".

Code	Desc.	Female panel	Male panel
4200003412	3/4F-1/2M	3/4	1/2

## Assorted sleeves 1/2 "Teng Tools



Code	Description
4430047814	839 - SERIES 21 PIECES

CONTENUTO	
n° 16	BUSSOLE POLIGONALI: 10;11;12;13;14;15;16;17;18;19;21 22;24;27;30;32 mm
n° 1	CRICCHETTO REVERSIBILE 1/2"
n° 1	PROLUNGA 63 mm
n° 1	PROLUNGA 150 mm
n° 1	SNODO CARDANICO
n° 1	RIDUZIONE DA 1/2" A 3/8"

TENGTOOLS



## Deposit bushings multisocket Meccanocar 1/2 "



- Practice safe deposit bushings multisocket 1/2 ".
- Product suitable for car and motorcycle repair shops, body shops, auto electrician, plant hi fi, campers, airports and maintenance.
- The kit includes a variety of accessories and bushings multisocket chrome vanadium extremely resistant.
- The profile multisocket fits screws with hexagonal profile, polygonal, in inches and Torx male.
- The particular ductility and strength of the sleeves allows to have a multipurpose instrument that allows to operate also in areas of poor accessibility.
- The kit consists of 25 pieces all available individually.
- Do not use compasses with air guns.

Code	Desc.
4200000590	828

TABELLA RIEPILOGATIVA BUSSOLE MULTIPRESA 1/2"		
ESAGONO/METRICO (MM)	POLLICI (INCH)	TORX
10	3/8"	E12
11	7/16"	E4
12	15/32"	-
13	1/2"	E16
14	9/16"	E18
15	19/32"	-
16	5/8"	E20
17	21/32"	-
18	11/16"	E22
19	3/4"	E24
20	25/32"	-
21	13/16"	E26
22	7/8"	E16
23	9/16"	E28
24	15/16"	E30
27	1-1/16"	E34
30	1-3/16"	E38
32	1-1/4"	E40

CONTENUTO KIT		CONTENUTO KIT	
420 00 00305	1032C - CRICCHETTO REVERS. 1/2"	420 00 00492	16 - BUSSOLA MULTIPR 1/2", 16mm
420 00 00380	1032P-125 - PROLUNGA 1/2" 125mm	420 00 00494	17 - BUSSOLA MULTIPR 1/2", 17mm
420 00 00382	1032P-250 - PROLUNGA 1/2" 250mm	420 00 00496	18 - BUSSOLA MULTIPR 1/2", 18mm
420 00 00384	1032S - SNODO CARDANICO 1/2"	420 00 00498	19 - BUSSOLA MULTIPR 1/2", 19mm
420 00 00517	250 1/2 - MANICO FISSO 1/2", 250mm	420 00 00500	20 - BUSSOLA MULTIPR 1/2", 20mm
420 00 00515	16C - BUSSOLA PER CANDELE	420 00 00502	21 - BUSSOLA MULTIPR 1/2", 21mm
420 00 00516	21C - BUSSOLA PER CANDELE	420 00 00504	22 - BUSSOLA MULTIPR 1/2", 22mm
420 00 00480	10 - BUSSOLA MULTIPR 1/2", 10mm	420 00 00506	23 - BUSSOLA MULTIPR 1/2", 23mm
420 00 00482	11 - BUSSOLA MULTIPR 1/2", 11mm	420 00 00508	24 - BUSSOLA MULTIPR 1/2", 24mm
420 00 00484	12 - BUSSOLA MULTIPR 1/2", 12mm	420 00 00510	27 - BUSSOLA MULTIPR 1/2", 27mm
420 00 00486	13 - BUSSOLA MULTIPR 1/2", 13mm	420 00 00512	30 - BUSSOLA MULTIPR 1/2", 30mm
420 00 00488	14 - BUSSOLA MULTIPR 1/2", 14mm	420 00 00514	32 - BUSSOLA MULTIPR 1/2", 32mm
420 00 00490	15 - BUSSOLA MULTIPR 1/2", 15mm		

## Kit bushings with system through

**CONTENUTO KIT**

Bussole con foro passante impronta universale	8,10,11,12,13,14,15,16,17,18,19 mm
Prolunga	75 mm
Cricchetto 180°	Passante - 195 mm
Adattatori	1/4" - 3/8"

- Assortment sockets with through hole and universal footprint.
- Suitable for car and motorcycle workshops, body shops, electrical and plumbing and heating industry.
- The bushings are characterized by the particular system go through that allows its use even in the presence of threaded bars, nuts, studs and screws protruding.
- The footprint of the universal bushings allows the use of multiple types of bolts: hexagonal (intact and damaged up to 50%), torx, square, and polygonal XZN.
- The ratchet flexible up to 180 ° and the thickness of the sleeve with ratchet (only 33 mm) allow you to easily work in areas where the room for maneuver is reduced.
- Cassette provided with two adapters with release buttons for use with bushings Classic 1/4 "and 3/8".
- Finishing components: polished chrome.
- Bushings provided practical metal box with thermoformed in order to keep the equipment.
- Case dimensions: the 244 x 40 x h p 120 mm.

Code	Description	N. Pieces
4200098600	36- kit bushings system through	15

Spare Parts	
Code	Description
4200098601	36 / CR-ratchet 180 ° - 195 mm
4200098602	36 / PR-extension 75 mm
4200098603	36 / AD1-adapter 1/4 "
4200098604	36 / AD2-adapter 3/8 "

8

## Bushings system footprint through universal

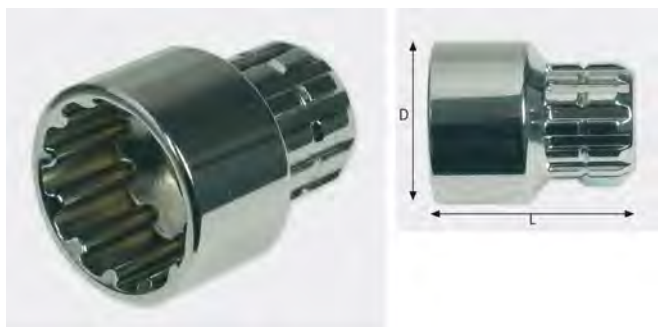

- Bushings with universal footprint and through hole.
- Multiple applications: hex bolts (intact and damaged up to 50%), Torx, XZN, square and polygonal.
- Finish: polished chrome steel.
- Used with the specific ratchet our code. 4200098601.

**Tabella riepilogativa bussole impronta universale**

Esagono/Metrico (mm)	Pollici (inch)	Torx	Quadro	Xzn
8	5/16"	E10	-	8
10	3/8"	E12	8	10
11	7/16"	E14	9	11
12	15/32"	-	10	12
13	1/2"	E16	-	13
14	9/16"	E18	-	14
15	19/32"	-	12	15
16	5/8"	E20	13	16
17	21/32"	-	14	17
18	11/16"	E22	-	18
19	3/4"	E24	-	19

Code	Desc.	Measure mm	L mm	D mm
4200098605	36/8	8	32	18,5
4200098606	36/10	10	32	18,5
4200098607	36/11	11	32	18,5
4200098608	36/12	12	32	18,5
4200098609	36/13	13	32	18,5
4200098610	36/14	14	32	20
4200098611	36/15	15	32	22
4200098612	36/16	16	32	23
4200098613	36/17	17	32	24,5
4200098614	36/18	18	32	25
4200098615	36/19	19	32	26,5



## Kit hexagonal sockets 1/2 "



Code	Description
420000300	1032 kit hexagonal sockets 1/2 "
420000305	1032C-1/2 " ratchet 72d.

KIT BUSSOLE ES. 1/2 "CONTENENTE:	
420 00 00305	1032C-1/2" CRICCO 72D
n° 18	BUSSOLE ESAGONALI C. M10-11-12-13-14-15-16-17-18-19-20-21-22-23-24-27-30-32
n° 1	SNODO CARDANICO
n° 2	PROLUNGHE mm 125-250
n° 1	IMPUGNATURA CON SNODO

## Kit bushes polygonal short 1/2 "



- Kit bushes polygonal short 15 pcs.
- Made of chrome-vanadium.
- In metal case. For all operator that already 'possess accessories for sockets 1/2 ".

Code	Description	Attachment
4200099035	Kit bushes polygonal short 10-32	1/2

CONTENUTO		
420 00 98990	10C Bussola poligonale corta	1
420 00 98991	11C Bussola poligonale corta	1
420 00 98992	12C Bussola poligonale corta	1
420 00 98993	13C Bussola poligonale corta	1
420 00 98994	14C Bussola poligonale corta	1
420 00 98995	15C Bussola poligonale corta	1
420 00 98996	16C Bussola poligonale corta	1
420 00 98997	17C Bussola poligonale corta	1
420 00 98999	19C Bussola poligonale corta	1
420 00 99021	21C Bussola poligonale corta	1
420 00 99022	22C Bussola poligonale corta	1
420 00 99024	24C Bussola poligonale corta	1
420 00 99027	27C Bussola poligonale corta	1
420 00 99030	30C Bussola poligonale corta	1
420 00 99032	32C Bussola poligonale corta	1

## Kit hexagonal sockets male 1/2 "



Code	Description
4200000310	kit compasses m. hexagonal 1/2 "c + l

COMPOSIZIONE KIT	
n° 10	BUSSOLE ESAGONALI MASCHIO CORTE mm 55: M5,6,7,8,9,10,12,14,17,19
n° 6	BUSSOLE ESAGONALI MASCHIO LUNGHE mm 140: M5,6,7,8,10,12



## Kit bushes Torx male 1/2 "



Code	Description
4200000330	Kit bushes male Torx 1/2 "c + l

CONTENUTO KIT	
n° 10	BUSSOLE TORX MASCHIO CORTE mm55: T15, T20, T25, T27, T30, T40, T45, T50, T55, T60
n° 10	BUSSOLE TORX MASCHIO LUNGHE mm 140: T15, T20, T25, T27, T30, T40, T45, T50, T55, T60

## Hexagonal sockets Short 3/4" Q. 19.5 mm

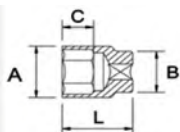

Code	Desc. Measure	Length L mm	Ø est. A mm	Ø est. attacco B mm	Mouth depth C mm
4200099119	19	50	30	36	14
4200099121	21	50	32	36	14
4200099122	22	50	33	36	14
4200099123	23	50	34	36	14
4200099124	24	50	35	36	16
4200099125	25	50	35	36	16
4200099126	26	50	36	36	16
4200099127	27	50	38	36	18
4200099128	28	50	40	36	18
4200099129	29	50	40	38	18
4200099130	30	55	42	38	20
4200099132	32	55	44	38	22
4200099133	33	55	46	38	22
4200099134	34	55	46	38	22
4200099135	35	60	48	42	23
4200099136	36	60	50	42	24
4200099138	38	60	50	45	24
4200099140	40	60	55	45	27
4200099141	41	65	55	45	27
4200099142	42	65	60	48	28
4200099146	46	70	60	48	30
4200099150	50	70	70	48	33
4200099154	54	75	70	48	36
4200099155	55	75	75	48	36
4200099160	60	80	80	48	39

- Hexagonal profile.
- Satin finish.
- Chromium-vanadium steel.
- To DIN 3124 standards.

## Bushings polygonal court 3/4" Q. 19.5 mm

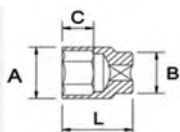

- Hexagonal profile.
- Satin finish.
- Chromium steel-vanadium.
- To DIN 3124 standards.

Code	Desc. Measure	Length L mm	Ø est. A mm	Ø est. attacco B mm	Mouth depth C mm
4200099219	19	50	30	36	14
4200099221	21	50	32	36	14
4200099222	22	50	33	36	14
4200099223	23	50	34	36	14
4200099224	24	50	35	36	16
4200099225	25	50	35	36	16
4200099226	26	50	36	36	16
4200099227	27	50	38	36	18
4200099228	29	50	40	38	18
4200099230	30	55	42	38	20
4200099232	32	55	44	38	22
4200099233	33	55	46	38	22
4200099234	34	60	46	38	22
4200099235	35	60	48	42	23
4200099236	36	60	50	42	24
4200099238	38	60	50	45	24
4200099240	40	60	55	45	27
4200099241	41	65	55	45	27
4200099242	42	65	60	45	28
4200099244	44	65	60	45	28
4200099246	46	70	60	48	30
4200099250	50	70	70	48	36
4200099254	54	75	70	48	36
4200099255	55	75	75	48	36

## Extension for sockets 3/4 "Q. 19.5 mm



- A DIN 3123 standards.
- Chrome-vanadium steel.

Code	Desc.	Length L mm
4200099304	100	100
4200099308	200	200

## Rod with slide for sockets 3/4 "Q. 19.5 mm



- To DIN 3123 standards.
- Made of chrome-vanadium.

Code	Length L mm	Description
4200099320	450	Auction sliding attachment

## Reversible ratchet for sockets 3/4" Q. 19.5 mm



- To DIN 3123 standards.
- Chromium-vanadium steel.
- Ratchet teeth 43

Code	Length <i>L mm</i>	Description
4200099300	500	ratchet 3/4

## Joint for sockets 3/4 "Q. 19.5 mm



- A DIN 3123 standards.
- Chrome-vanadium steel.

Code	Length <i>L mm</i>	Description
4200099310	110	joint 3/4

## Kit hexagonal sockets short 3/4 "



- Kit bushes + accessories connection 3/4 Enclosed.
- Made of chrome-vanadium.

Code	Description	Attachment
4200099170	Kit hexagonal sockets short 22-50	3/4

CONTENUTO		
420 00 99122	22 Bussola esagonale corta	1
420 00 99124	24 Bussola esagonale corta	1
420 00 99127	27 Bussola esagonale corta	1
420 00 99130	30 Bussola esagonale corta	1
420 00 99132	32 Bussola esagonale corta	1
420 00 99136	36 Bussola esagonale corta	1
420 00 99138	38 Bussola esagonale corta	1
420 00 99141	41 Bussola esagonale corta	1
420 00 99146	46 Bussola esagonale corta	1
420 00 99150	50 Bussola esagonale corta	1
420 00 99300	Cricco reversibile	1
420 00 99320	Asta con attacco scorrevole	1
420 00 99304	Prolunga L100mm	1
420 00 99308	Prolunga L200mm	1

## Deposit hexagonal sockets 3/4 "



- Hexagonal sockets from the measure 19 to measure 50.
- With system safety closure of the compass on the accessory.
- In practice suitcase in plastic material.
- For all workshops car and truck maintenance workers in general.

Code	Desc.
4430039010	434/1

CONTENUTO	
N°16	bussole esagonali: 19-21-22-23-24-26 27-29-30-32-35-36-38-41-46-50
N°3	prolunghe: 4"-8"-16"
N°1	asta scorrevole: L. 450mm
443 00 39011	1 cricco reversibile: 40 denti

## Bushings bolt damaged 1/2"



- Socket set with coned coil.
- Suitable for car workshops, tire repairers and bodywork.
- Allow it to loosen and remove easily, safe and timely nuts and bolts locked, with threads or damaged heads and / or rounded.
- Particularly useful to remove bolts "theft" mounted on the wheels of most cars on the road.
- The conical helical profile allows the compass to firmly engage the screw or bolt in order to create a sturdy grip.
- The series carries a lower expenditure of time and energy in the process of unlocking and less risk of damage to the bolt.
- Content box: 4 bushings with 1/2 "metal rod to eject the 80mm bolt compasses.

Code	Desc.	Content
4770005320	620	Kit 4 bushings conical coil: 17-19-21-23 mm
4770005321	620/17	17 mm
4770005322	620/19	19 mm
4770005323	620/21	21 mm
4770005324	620/23	23 mm



## Bushings reinforced 1/2" standard series

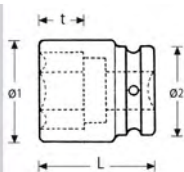

Code	Desc. Ø mm	Ø 1 mm	Ø 2 mm	L mm	t mm
4430002700	190 - 10	17,5	25	40	6
4430002800	190 - 11	19	25	40	7
4430002900	190 - 12	20	25	40	8
4430003000	190 - 13	21,5	25	40	8
4430003100	190 - 14	22,5	25	40	10
4430003200	190 - 15	24	30	40	10
4430003250	190 - 16	25	30	40	10
4430003300	190 - 17	26,5	30	40	10
4430003350	190 - 18	27,5	30	40	12
4430003400	190 - 19	29	30	40	12
4430003420	190 - 20	30	30	40	12
4430003430	190 - 21	31,5	30	40	14
4430003500	190 - 22	32,5	30	40	14
4430003550	190 - 23	34	30	40	14
4430003600	190 - 24	35	30	45	16
4430003700	190 - 27	39	30	48	18
4430003800	190 - 30	42,5	30	48	20
4430003810	190 - 32	45	30	50	22
4430003820	190 - 34	48	35	50	22
4430003830	190 - 36	50	35	50	24

- Execution black.

## Bushings reinforced 1/2" long series

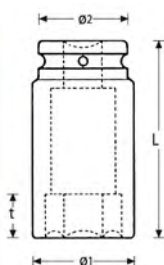

Code	Desc. Ø mm	Ø 1 mm	Ø 2 mm	L mm	t mm
4430003860	191 - 8	15	25	85	5
4430003870	191 - 10	17,5	25	85	6
4430003875	191 - 11	19	25	85	7
4430003880	191 - 12	20	25	85	8
4430003900	191 - 13	21,5	25	85	8
4430003920	191 - 14	22,5	25	85	10
4430003930	191 - 15	24	30	85	10
4430003940	191 - 16	25	30	85	10
4430004000	191 - 17	26,5	30	85	10
4430004050	191 - 18	27,5	30	85	12
4430004100	191 - 19	29	30	85	12
4430004130	191 - 21	31,5	30	85	14
4430004200	191 - 22	32,5	30	85	14
4430004300	191 - 24	35	30	85	16
4430004400	191 - 27	39	30	85	18
4430004430	191 - 30	42,5	30	85	20
4430004440	191 - 32	45	30	85	22
4430004450	191 - 34	48	35	85	22

- Execution black.

## Reinforced sockets kit 1/2" 10 pcs



- Reinforced socket kit intended for pneumatic tools
- Handy plastic container with 10 sockets
- It contains 10 sockets from 11 to 24
- Especially suitable for mechanics, workshops, and installers.

Code	Description	Attachment
4430058210	Reinforced sockets kit 1/2" 10 pcs	1/2"

Spare Parts			
Article	Code	Desc.	
Reinforced hexagonal socket wrench 1/2"	4430002800	190-11	
Reinforced hexagonal socket wrench 1/2"	4430002900	190-12	
Reinforced hexagonal socket wrench 1/2"	4430003000	190-13	
Reinforced hexagonal socket wrench 1/2"	4430003100	190-14	
Reinforced hexagonal socket wrench 1/2"	4430003250	190-16	
Reinforced hexagonal socket wrench 1/2"	4430003300	190-17	
Chiave a bussola esagonale 1/2 rinf.	4430003400	190-19	
Reinforced hexagonal socket wrench 1/2"	4430003430	190-21	
Reinforced hexagonal socket wrench 1/2"	4430003500	190-22	
Reinforced hexagonal socket wrench 1/2"	4430003600	190-24	



## Reinforced sockets kit 1/2" - 15 PZ.



- Reinforced socket kit intended for pneumatic tools
- Handy plastic container with 15 sockets
- It contains 10 sockets from 10 to 32
- All sizes always at hand...
- Especially suitable for mechanics, workshops, and installers.

Code	Description	Attachment
4430058220	Kit bussole rinforzate 1/2" - 15 PZ.	1/2"

Spare Parts		
Article	Code	Desc.
Reinforced hexagonal socket wrench 1/2"	4430002700	190-10
Reinforced hexagonal socket wrench 1/2"	4430002800	190-11
Reinforced hexagonal socket wrench 1/2"	4430002900	190-12
Reinforced hexagonal socket wrench 1/2"	4430003000	190-13
Reinforced hexagonal socket wrench 1/2"	4430003100	190-14
Reinforced hexagonal socket wrench 1/2"	4430003200	190-15
Reinforced hexagonal socket wrench 1/2"	4430003250	190-16
Reinforced hexagonal socket wrench 1/2"	4430003300	190-17
Reinforced hexagonal socket wrench 1/2"	4430003400	190-19
Reinforced hexagonal socket wrench 1/2"	4430003430	190-21
Reinforced hexagonal socket wrench 1/2"	4430003500	190-22
Reinforced hexagonal socket wrench 1/2"	4430003600	190-24
Reinforced hexagonal socket wrench 1/2"	4430003700	190-27
Reinforced hexagonal socket wrench 1/2"	4430003800	190-30
Reinforced hexagonal socket wrench 1/2"	4430003810	190-32

## Kit of 10 long reinforced sockets 11-24



- Reinforced socket kit intended for pneumatic tools
- Handy plastic container with 10 sockets
- It contains 10 sockets from 11 to 24
- Long version necessary for studs and through screws
- Especially suitable for mechanics, workshops, and installers

Code	Description	Attachment
4430058230	Kit of 10 long reinforced sockets 11-24	1/2"

Spare Parts		
Article	Code	Desc.
Long reinforced hexagonal socket wrench 1/2"	4430003875	191-11
Long reinforced hexagonal socket wrench 1/2"	4430003880	191-12
Long reinforced hexagonal socket wrench 1/2"	4430003900	191-13
Long reinforced hexagonal socket wrench 1/2"	4430003920	191-14
Long reinforced hexagonal socket wrench 1/2"	4430003940	191-16
Long reinforced hexagonal socket wrench 1/2"	4430004000	191-17
Long reinforced hexagonal socket wrench 1/2"	4430004100	191-19
Long reinforced hexagonal socket wrench 1/2"	4430004130	191-21
Long reinforced hexagonal socket wrench 1/2"	4430004200	191-22
Long reinforced hexagonal socket wrench 1/2"	4430004300	191-24

## Bushings reinforced hexagonal profile male

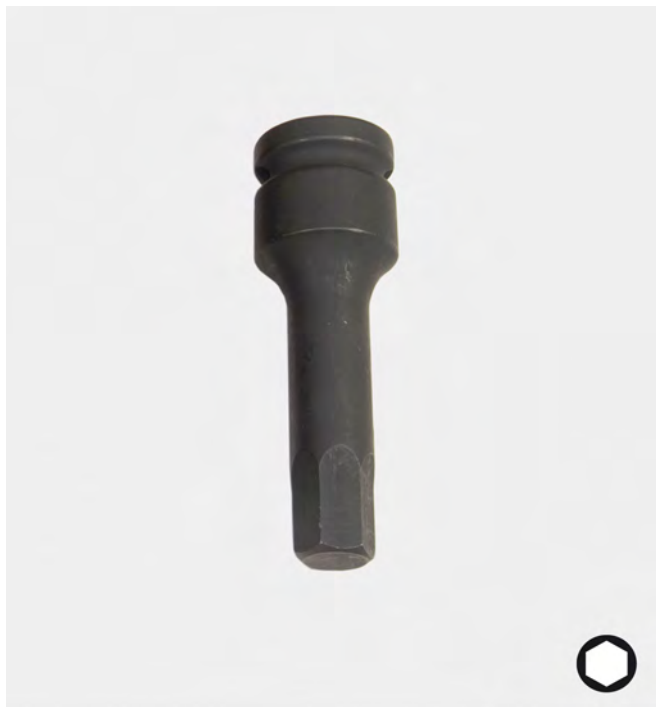

- Bushings with 1/2" steel high-strength for use with pneumatic tools.
- The single body with the tool guarantees a long life even when subjected to stress by use with pneumatic tools.
- Particularly suitable for repair and body shops where the normal bushings are not able to withstand without breaking when used with screwdrivers.

Code	Desc.	Control panel attachment
4200099345	5-L78	1/2
4200099346	6-L78	1/2
4200099347	7-L78	1/2
4200099348	8-L78	1/2
4200099350	10-L78	1/2
4200099352	12-L78	1/2
4200099354	14-L78	1/2
4200099357	17-L78	1/2
4200099359	19-L78	1/2

8

## Kit bushes reinforced profiles hexagonal male



Cod. 4200099330

- In practical plastic case.
- Kit 5 compasses containing measures 5-6-8-10-12
- Kit 9 compasses containing measures 5-6-7-8-10-12-14-17-19

Code	Desc.	Control panel attachment
4200099330	5-12-L78	1/2
4200099335	5-19-L78	1/2



Cod. 4200099335

## Bushings reinforced profile male XZN



- Bushings with 1/2" steel high-strength for use with pneumatic tools.
- The single body with the tool guarantees a long life even when subjected to the stress from use with pneumatic tools.
- Particularly suitable for repair and body shops where the normal bushings are not able to withstand without breaking when used with screwdrivers.

Code	Desc.	Control panel attachment
4200099425	M5-L78	1/2
4200099426	M6-L78	1/2
4200099428	M8-L78	1/2
4200099430	M10-L78	1/2
4200099432	M12-L78	1/2
4200099434	M14-L78	1/2
4200099436	M16-L78	1/2

## Kit bushes reinforced profiles XZN male



- In practical plastic case.
- Kit containing No. 5 compasses measure m5-6-8-10-12.

Code	Desc.	Control panel attachment
4200099420	5-12-L78	1/2

## Bushings reinforced profile male TORX



- Bushings with 1/2" steel high-strength for use with pneumatic tools.
- The single body with the tool guarantees a long life even when subjected to stress by use with pneumatic tools.
- Particularly suitable for repair and body shops where the normal bushings are not able to withstand without breaking when used with screwdrivers.

Code	Desc.	Control panel attachment
4200099365	TX25-L78	1/2
4200099367	TX27-L78	1/2
4200099370	TX30-L78	1/2
4200099380	TX40-L78	1/2
4200099385	TX45-L78	1/2
4200099390	TX50-L78	1/2
4200099395	TX55-L78	1/2
4200099400	TX60-L78	1/2
4200099410	TX70-L78	1/2

8

## Kit bushes reinforced profiles TORX male



- In practical plastic case.
- Kit 9 compasses containing the measure TX25 -27-30-40-45-50-55-60-70.

Code	Desc.	Control panel attachment
4200099360	TX25-TX70-L78	1/2

## Jointed socket wrench 1/2"



- Jointed socket wrench with locking ring
- Dual utilisation: can be utilised as a normal reinforced extended socket wrench and when necessary, adjusting the ring, it becomes a practical joint to access parts that cannot be reached by normal extension socket wrenches.
- Indicated for mechanics and bodyshop mechanics.

Code	Description	Length
4430058170	Extended jointed socket wrench 1/2"	95 mm

## Extended ratchet socket wrench 1/2"



- Extended ratchet socket wrench
- Practical extended socket wrench 1/2" with reversible ratchet system
- 22mm external hexagonal profile (female attachment)
- When necessary, it becomes a reversible ratchet socket wrench, saving the time of the operator during assembly and disassembly.

Code	Description	Length
4430058180	Extended ratchet socket wrench 1/2"	65mm

## Fittings reinforced 1/2 "

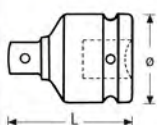

- Execution black.
- Internal 1/2" - external 4.3".

Code	Desc.	Attachment panel control female	Attachment panel control male	Ø mm	L mm
4430004500	192	1/2"	3/4"	30	50

## Extensions reinforced 1/2 "

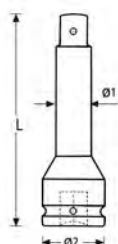

Code	Desc.	Attachment panel control female	Attachment panel control male	Ø 1 mm	Ø 2 mm	L mm
4430004600	193	1/2"	1/2"	16,5	30	75
4430004700	194	1/2"	1/2"	16,5	30	125
44300046402	713	1/2"	1/2"	16,5	30	250

## Reinforced joint 1/2 "

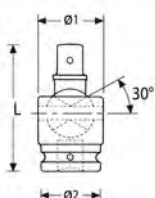

Code	Desc.	Attachment panel control female	Attachment panel control male	Ø 1 mm	Ø 2 mm	L mm
4430004800	195	1/2"	1/2"	34	30	60



## Bushings reinforced 3/4" standard series

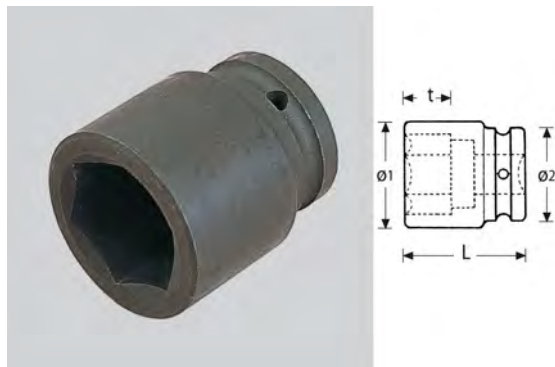

Code	Desc. Ø mm	Ø 1 mm	Ø 2 mm	L mm	t mm
4430004900	196 - 17	31	44	51	10
4430005000	196 - 19	33,5	44	51	12
4430005030	196 - 21	36	44	51	14
4430005100	196 - 22	37	44	51	14
4430005200	196 - 24	39,5	44	51	16
4430005230	196 - 26	41	44	45	16
4430005300	196 - 27	43,5	44	54	18
4430005330	196 - 29	44	44	50	18
4430005400	196 - 30	47	44	54	20
4430005500	196 - 32	49,5	44	57	22
4430005600	196 - 33	51	44	57	22
4430005610	196 - 34	52	44	57	22
4430005700	196 - 36	54,5	44	57	24
4430005800	196 - 38	57	44	57	24
4430005900	196 - 41	61	44	58	27
4430006000	196 - 46	67	44	63	30

- Execution black.

## Bushings reinforced 3/4" long series

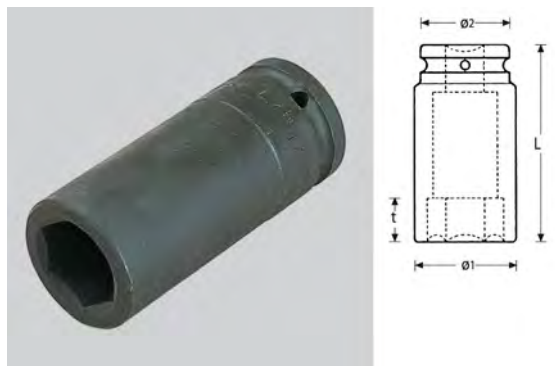

Code	Desc. Ø mm	Ø 1 mm	Ø 2 mm	L mm	t mm
4430006100	197 - 17	31	44	100	10
4430006200	197 - 19	33,5	44	100	12
4430006230	197 - 21	36	44	100	14
4430006300	197 - 22	37	44	100	14
4430006400	197 - 24	39,5	44	100	16
4430006500	197 - 27	43,5	44	100	18
4430006600	197 - 30	47	44	100	20
4430006700	197 - 32	49,5	44	100	22
4430006800	197 - 33	51	44	100	22
4430006830	197 - 34	52	44	100	22
4430006900	197 - 36	54,5	44	100	24
4430006930	197 - 41	61	44	100	27
4430006950	197 - 46	67	44	105	30

- Execution black.

## Fittings reinforced 3/4 "



- Execution black
- 1) Internal 3/4 "- external 2.1".
- 2) Internal 3/4 "- external 1.

Code	Desc.	Attachment <i>panel control female</i>	Attachment <i>panel control male</i>	Ø mm	L mm
4430007100	199(1)	3/4"	1/2"	44	60
4430007200	200(2)	3/4"	1"	44	60

## Extensions reinforced 3/4 "



Code	Desc.	Attachment <i>panel control female</i>	Attachment <i>panel control male</i>	Ø 1 mm	Ø 2 mm	L mm
4430046482	717	3/4"	1/2"	16,5	44	175
4430007300	201	3/4"	3/4"	25	44	175
4430046484	718	3/4"	3/4"	25	44	250
4430046486	719	3/4"	3/4"	25	44	330

## Reinforced joint Q. 3/4 "

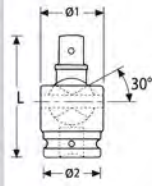

- Execution black.

Code	Desc.	Attachment <i>panel control female</i>	Attachment <i>panel control male</i>	Ø 1 mm	Ø 2 mm	L mm
4430007400	202	3/4"	3/4"	48	44	88

## Bushings reinforced attack 1" standard series

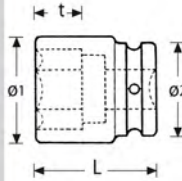

- Execution black.

Code	Desc. Ø mm	Ø 1 mm	Ø 2 mm	L mm	t mm
4430007550	204 - 19	36,5	54	58	12
4430007570	204 - 21	39	54	58	14
4430007600	204 - 22	40	54	58	14
4430007700	204 - 24	42,5	54	60	16
4430007800	204 - 27	46,5	54	60	18
4430007850	204 - 28	47,5	54	60	18
4430007900	204 - 30	50	54	62	22
4430008000	204 - 32	52,5	54	63	22
4430008100	204 - 33	54	54	63	22
4430008200	204 - 36	59	54	67	24
4430008300	204 - 38	60	54	67	27
4430008400	204 - 41	64	54	70	27
4430008500	204 - 46	70	54	76	30
4430008650	204 - 52	77,5	54	87	33

## Bushings reinforced attack 1" long series

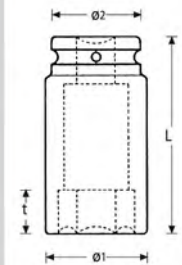

- Running black.

Code	Desc. Ø mm	Ø 1 mm	Ø 2 mm	L mm	t mm
4430009060	205 - 19	36,5	54	110	12
4430009070	205 - 20	38	54	110	12
4430009080	205 - 21	39	54	110	14
4430009085	205 - 22	40	54	110	14
4430009100	205 - 24	42,5	54	110	16
4430009200	205 - 27	46,5	54	110	18
4430009300	205 - 30	50	54	110	20
4430009400	205 - 32	52,5	54	110	22
4430009500	205 - 33	54	54	110	22
4430009550	205 - 34	55	54	110	22
4430009600	205 - 36	59	54	110	24
4430009700	205 - 38	60	54	110	24
4430009800	205 - 41	64	54	110	27
4430009900	205 - 46	70	54	110	30
4430010050	205 - 52	77,5	54	115	33

## Fittings reinforced 1 "

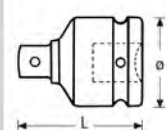

- Execution black.
- Inside 1" - external 4.3".

Code	Desc.	Attachment <i>panel control female</i>	Attachment <i>panel control male</i>	Ø mm	L mm
4430010400	207	1"	3/4"	54	74

## Extension reinforced 1 "

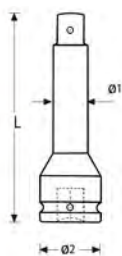

- Running black.

Code	Desc.	Attachment <i>panel control female</i>	Attachment <i>panel control male</i>	Ø 1 mm	Ø 2 mm	L mm
4430010500	208	1"	1"	33	54	175
4430046500	726	1"	1"	33	54	330

## Reinforced Joint 1 "

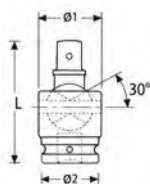

- Execution black.
- Avoid touching the socket during use.
- Caution: Always use eye protection when using impact tools.

Code	Desc.	Attachment <i>panel control female</i>	Attachment <i>panel control male</i>	Ø 1 mm	Ø 2 mm	L mm
4430010600	209	1"	1"	60	54	110

## Bushing nut hubs VW



- Bushing special long version.
- Square drive 1/2", polygonal M30.
- Specification for dismantling the central nut mounted on the wheel hubs cars VW, Mercedes and so on.

Code	Desc.	Measure mm
4770001880	188 - 30	30

## Bushing nut hubs Fiat Ducato



- Bushing in turning special.
- 3/4" square drive hexagon M41.
- Essential for removal of wheel hub nuts vans Ducato and Peugeot.

Code	Desc.	Measure mm	Attachment
4770001870	187 - 41	41	3/4"

## Bush for ring nuts Fiat



- Bushing Special taper turning.
- 3/4 "square, polygonal 36 m.
- Specification for removing the central nut mounted on wheel hub Fiat, Alfa Romeo, Lancia, BMW AS5 96 ---> oil filter cap.
- Thanks to the extraordinary strength and 'use with impact wrench.

Code	Desc.	Measure mm	Attachment
4770000930	93-36	36	3/4"

## Polygonal socket wrench



- Painted carbon steel
- Size 56 suitable for hubs Ford Transit
- Size 65 suitable for hubs Daily

Code	Desc. Measures	Attachment
4430024065	307-56	1"
4430024080	307-65	1"

## Polygonal socket wrenches



- In phosphate-coated steel
- Execution suitable for the use with screwdrivers
- Size suitable for hubs Cursor front 105
- Size suitable for hubs Cursor front 115

Code	Desc. Measures	Attachment
4430024150	307-105	1"
4430024170	307-115	1"

## Polygonal socket wrenches with sleeve



- In phosphate-coated steel
- Execution suitable for the use with screwdrivers
- Size suitable for hubs Nuovo Eurocargo 90 mm
- Size suitable for hubs Nuovo Eurocargo 95 mm
- Size suitable for hubs Cursor rear 105 mm

Code	Desc. Measures	Attachment
4770005100	400-90	1"
4770005110	410-95	1"
4770005120	420-105	1"

## Hexagonal socket wrenches



- In phosphate-coated steel
- Execution suitable for the use with screwdrivers

Code	Desc. <i>Measures</i>	Attachment
4770001541	155-65	1"
4770001544	155-70	1"
4770001546	155-85	1"
4770001548	155-90	1"
4770001550	155-94	1"
4770005140	440-95	1"
4770001552	155-100	1"
4770005150	450-105	1"
4770005160	460-110	1"
4770005170	470-120	1"

## Octagonal socket wrenches



- In phosphate-coated steel
- Execution suitable for the use with screwdrivers

Code	Desc. <i>Measures</i>	Attachment
4770002054	206-70	1"
4770005180	480-80	1"
4770002057	206-82	1"
4770002058	206-83	1"
4770002060	206-86	1"
4770002070	206-95	1"
4770002074	206-96	1"
4770005200	500-100	1"

8

## Hexagonal socket wrenches with sleeve



- In phosphate-coated steel
- Execution suitable for the use with screwdrivers
- Size suitable for hubs Nuovo Eurocargo 85 mm

Code	Desc. <i>Measures</i>	Attachment
4770001760	176-85	1"
4770001764	176-95	1"



## Utensils in stainless steel

The tools made of steel are still in demand on the market.

This is because as well as being clearly immune from oxidation and therefore NOT rust, are increasingly in demand in the food, pharmaceutical and hospital, as required as anti-bacterial.

In mechanics, if we work on stainless steel with stainless steel utensils not, these can leave shavings, chips of steel on steel Inox creating adhering to the principle of oxidation, rust creating landfills. The rust on steel is called "rust improper", as it is very difficult to remove, it may be necessary to replace parts in stainless steel.

Utensils in stainless steel Meccanocar by Wera, are tempered vacuum ice and thus have the hardness and strength required for working with stainless steel. They are reinforced carbon soul. It is easily recognizable for their handle color blue or light blue band.

Utensils in stainless steel Meccanocar by Wera are ideal for use in high humidity environments. **Lasertip**- Thanks to a laser treatment with concentrated beam, you get a surface with grooves furrows sharp. This treatment gives a high GRIP at the tips, so as to avoid pressure and thrust to transmit high torques. The grooves make that the screw head is joining perfectly with the tip of the blade, preventing slipping and greatly increasing the force transmission from the hand tool.

### Screwdriver stainless steel. Tipped Lasertip



- For slotted screws
- round blade
- Stainless steel tip with Lasertip
- Handle anti-rolling and multicomponent.
- \*\* without Lasertip

Code	Desc.	Spessore punta	Width tip	Ø lama	Length blade
4200100100	3335-3x80**	0,5 mm	3,0 mm	3,0 mm	80 mm
4200100105	3335-3,5x100	0,6 mm	3,5 mm	3,5 mm	100 mm
4200100110	3335-4x100	0,8 mm	4,0 mm	4,0 mm	100 mm
4200100115	3335-5,5x125	1,0 mm	5,5 mm	5,5 mm	125 mm

### Screwdriver stainless steel. Tipped Lasertip

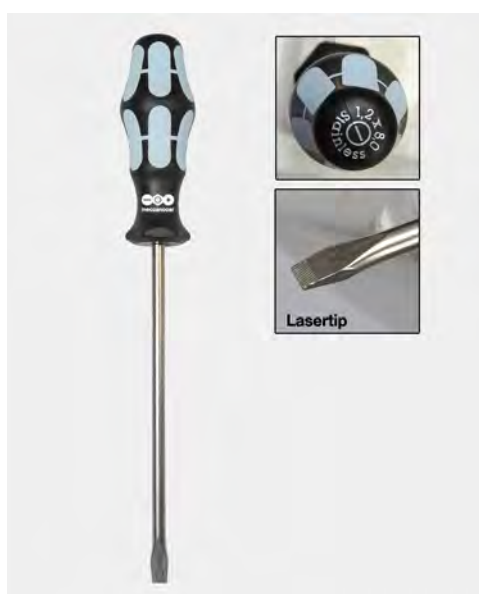

- For slotted screws
- round blade
- Stainless steel tip with Lasertip
- Handle anti-rolling and multicomponent.

Code	Desc.	Spessore punta	Width tip	Ø lama	Length blade
4200100120	3334-6,5x150	1,2 mm	6,5 mm	6,00 mm	150 mm
4200100125	3334-8x175	1,2 mm	8,0 mm	7,00 mm	175 mm
4200100130	3334-10x200	1,6 mm	10,0 mm	9,00 mm	200 mm

## Phillips screwdriver PH stainless steel. Tipped Lasertip



- Per viti a croce PH-Phillips
- Lama tonda
- In acciaio inox con punta Lasertip
- Impugnatura anti-rotolamento e multicomponente.
- \*\* Senza lasertip

Code	Desc.	Imprint	Ø lama	Length blade
4200100135	3350-PH0 **	PH0	3,0 mm	60 mm
4200100140	3350-PH1	PH1	4,5 mm	80 mm
4200100145	3350-PH2	PH2	6,0 mm	100 mm
4200100150	3350-PH3	PH3	8,0 mm	150 mm

## Phillips screwdriver PZ stainless steel. Tipped Lasertip



- Per viti a croce PZ-Pozidriv
- Lama tonda
- In acciaio inox con punta Lasertip
- Impugnatura anti-rotolamento e multicomponente.

Code	Desc.	Imprint	Ø lama	Length blade
4200100155	3355-PZ0 **	PZ0	3,0 mm	60 mm
4200100160	3355-PZ1	PZ1	4,5 mm	80 mm
4200100165	3355-PZ2	PZ2	6,0 mm	100 mm
4200100170	3355-PZ3	PZ3	8,0 mm	150 mm

## Torx screwdriver stainless steel



- For Torx screws recessed
- round blade
- Stainless steel
- Handle anti-rolling and multicomponent.

Code	Desc.	Imprint	Ø lama	Length blade
4200100175	3367-TX10	TX10	4,0 mm	80 mm
4200100180	3367-TX15	TX15	4,0 mm	80 mm
4200100185	3367-TX20	TX20	4,5 mm	100 mm
4200100190	3367-TX25	TX25	5,0 mm	100 mm
4200100195	3367-TX30	TX30	6,0 mm	115 mm
4200100200	3367-TX40	TX40	7,0 mm	130 mm

## BY WERA screwdriver MECCANOCAR

- A range that offers the right tool for each type of screwing
- With handle in two colors, green and white, multi, can work quickly without straining your hand thanks to the innovative ergonomics and components to slip.
- Measurement and blade length stamped into the base and on the side of the handle for quick identification the screwdriver in the set of tools.
- With hexagon anti-rolling at the bottom of the handle, preventing the tool resting on inclined surfaces rolling away.
- The tips of the screwdriver are hardened material with very high resistance to mechanical stresses and corrosion (black point and the blade tip in chrome molybdenum)

## Screwdriver



- For slotted screws
- round knife
- Satin nickel plated with black point tip
- Handle anti-rolling and multicomponent.
- The extent 6x125 blade mechanical

Code	Desc.	Spessore punta	Width tip	Ø lama	Length blade
4200100205	1335-2,5x75	0,4 mm	2,5 mm	2,5 mm	75 mm
4200100210	1335-3x80	0,5 mm	3,0 mm	3,0 mm	80 mm
4200100215	1335-4x100	0,8 mm	4,0 mm	4,0 mm	100 mm
4200100220	1335-5,5x150	1,0 mm	5,5 mm	5,5 mm	150 mm
4200100225	1334-6x125	1,0 mm	6,0 mm	6,0 mm	125 mm
4200100230	1334-8x175	1,2 mm	8,0 mm	8,0 mm	175 mm
4200100235	1334-10x200	1,6 mm	10,0 mm	10,0 mm	200 mm

## slotted long version screwdriver



- For slotted screws
- Round shaft
- Nickel finish with black tip
- Non-rotational and multicomponent handle

Code	Desc.	Spessore punta	Width tip	Ø lama	Length blade	Photo
4200100217	1335-4x300	0,8 mm	4 mm	4 mm	300 mm	1
4200100223	1335-5,5x300	1 mm	5 mm	5 mm	300 mm	1
4200100237	1334-12x250	2 mm	12 mm	10 mm	250 mm	2
4200100238	1334-14x250	2,5 mm	14 mm	12 mm	250 mm	3

## Screwdriver dwarf cut carburetor and motorcycles



- For slotted screws
- round knife
- Satin nickel plated with black point tip
- Handle anti-rolling to a component

Code	Desc.	Spessore punta	Width tip	Ø lama	Length blade
4200100240	110070-5,5x25	1,0 mm	5,5 mm	5,5 mm	25 mm

## Screwdriver dwarf cross carburetor and motorcycles



- For Phillips screws
- round knife
- Satin nickel plated with black point tip
- Handle anti-rolling to a component

Code	Desc.	Imprint	Ø lama	Length blade
4200100245	008775-PH 1	PH 1	4,5 mm	25 mm
4200100250	008780-PH 2	PH 2	6,0 mm	25 mm

## Phillips screwdriver PH



- For Phillips screws PH
- round knife
- Satin nickel plated with black point tip
- Handle non-roll multicomponent

Code	Desc.	Imprint	Ø punta	Length blade
4200100255	1350-PH0	PH0	3,0 mm	60 mm
4200100260	1350-PH1	PH1	4,5 mm	80 mm
4200100265	1350-PH1 x200	PH1	4,5 mm	200 mm
4200100270	1350-PH2	PH2	6,0 mm	100 mm
4200100275	1350-PH2x200	PH2	6,0 mm	200 mm
4200100280	1350-PH3	PH3	8,0 mm	150 mm

## Phillips long version screwdriver

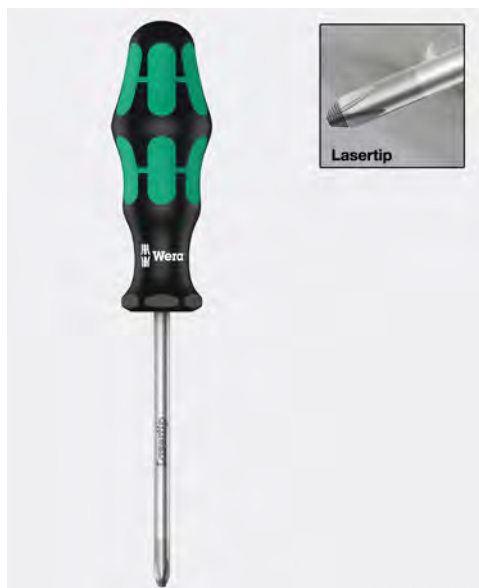

- For Phillips' screws
- Extra-long round shaft
- Nickel finish with black tip
- Non-rotational and multicomponent handle

Code	Desc.	Imprint	Ø punta	Length blade
4200100267	1350-PH1x300	PH1	4,5 mm	300 mm
4200100277	1350-PH2x300	PH2	6 mm	300 mm

## Phillips screwdriver Pozidriv PZ

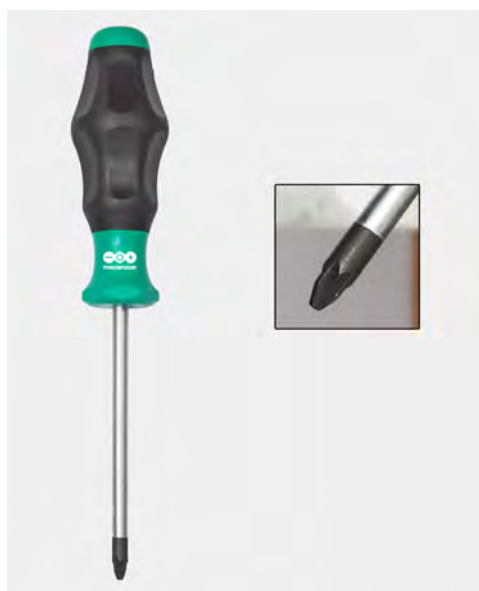

- Screw Pozidriv
- round knife
- Satin nickel plated with black point tip
- Handle non-roll multicomponent

Code	Desc.	Imprint	Ø punta	Length blade
4200100285	1355PZ-PZ1	PZ1	4,5 mm	80 mm
4200100290	1355PZ-PZ2	PZ2	6,00 mm	100 mm
4200100295	1355PZ-PZ3	PZ3	8,00 mm	150 mm

## Torx screwdriver



- For Torx screws recessed
- round blade
- Satin nickel plated with black point tip
- Handle anti-rolling and multicomponent.

Code	Desc.	Imprint	Ø lama	Length blade
4200100300	1367-TX8	TX8	3,5 mm	60 mm
4200100305	1367-TX10	TX10	4,0 mm	80 mm
4200100310	1367-TX15	TX15	4,0 mm	80 mm
4200100315	1367-TX20	TX20	4,5 mm	100 mm
4200100320	1367-TX25	TX25	5,0 mm	100 mm
4200100325	1367-TX27	TX27	5,5 mm	115 mm
4200100330	1367-TX30	TX30	6,0 mm	115 mm
4200100335	1367-TX40	TX40	7,0 mm	130 mm



## Flexible screwdriver with hexagonal socket

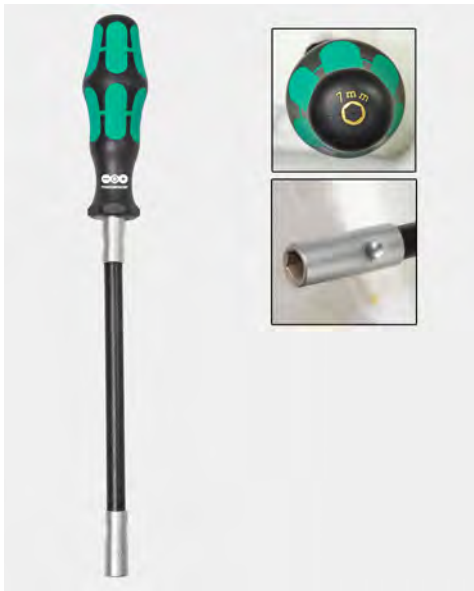

- For hex head screws
- Round blade and flexible
- Key for hexagonal screws
- Handle anti-rolling and multicomponent.
- \* Specific Screw metal clamps

Code	Desc.	Hexagonal wrench mm	Length blade
4200100340	391-6	6	167 mm
4200100345	391-7 *	7	167 mm
4200100350	391-8	8	167 mm

## BY series isolated MECCANOCAR screwdriver WERA VDE

- A mother who provides the right tool for each type of screwing, in safety, on of installations subject to the passage of electric voltage.
- The Wera VDE screwdriver are produced by testing every single screwdriver liquid subject to voltage of 10,000 volts to DIN EN 60900 (IEC60900: 2004), evidence that ensure perfect protection during live working up to 1,000 volts.
- These tests combined with the cold resistance tested at -40 ° C give a particularly high resistance to the mechanical stresses on the blade.
- With peaks in laser treated, this treatment causes on the surface of the tip are created knurls with a hardness equal to or greater than 1000 Vickers. In this way the tip mates perfectly with the head of the screw, the screwdriver does not slip and the safety is higher.
- Handle with two-color, yellow and red, multi-component, allows you to work quickly without straining your hand thanks to the innovative ergonomics and soft components to slip.
- Measurement and blade length stamped into the base and on the side of the handle for easy identification of the screwdriver in the set of tools.
- With hexagon anti-rolling at the bottom of the handle, preventing the tool resting on inclined surfaces via rolls

## VDE insulated screwdriver shear type electrician



- For slotted screws
- Isolated knife tested in accordance with IEC 60900: 2004
- With conical blade tip Black Point
- Handle anti-rolling and multicomponent.

Code	Desc.	Spessore punta	Width tip	Length blade
4200100355	1160i VDE-2,5x80	0,4 mm	2,5 mm	80 mm
4200100360	1160i VDE-3,0x100	0,5 mm	3,0 mm	100 mm
4200100365	1160i VDE-3,5x100	0,6 mm	3,5 mm	100 mm
4200100370	1160i VDE-4,0x100	0,8 mm	4,0 mm	100 mm
4200100375	1160i VDE-5,5x125	1,0 mm	5,5 mm	125 mm

## VDE insulated screwdriver Phillips PH



- For Phillips screws
- Isolated knife tested in accordance with IEC 60900: 2004
- Tip Black Point
- Handle anti-rolling and multicomponent

Code	Desc.	Imprint	Length blade
4200100380	1162 i VDE-PH1	PH1	80 mm
4200100385	1162 i VDE-PH2	PH2	100 mm

## Series dual blades VDE + tester, 16 pieces



- Individually tested to 10,000 volts.
- Blade length 154 mm
- 16 pieces

### • CONTENT:

- 1 handle to blade; 1-tester 3x70; 1-cutting 2,5x154, 1-taglio3,5x154; 1 4x154-cutting; 1-cutting 5,5x154; 1-ph1x154; 1-ph2x154; 1-ph / pz1x154 (profile plus minus); 1-ph / pz2x154 (profile plus minus); 1-1pzx154; 1-2pzx154; 1-tx10x154; 1-tx25x154; 1-tx15x154; 1-tx20x154

Code	Desc.
4200100390	003470-VDE 60

## 5 Series Phillips screwdrivers Meccanocar Cutting and Cross with support Mecrack



- Per viti a Taglio e a croce Phillips
- Lama rotonda
- Nichelato opaco con punta black point
- Impugnatura anti-rotolamento multicomponente
- **CONTENUTO:** Taglio: 2,5x75-4x100-5,5x150 ; Croce PH: PH1-PH2

Code	Description
4200100400	5-series 5 screwdrivers Meccanocar

## Series 6 screwdrivers Meccanocar Cut, Cross Phillips supporting Mecrack



- For screw cutting-Phillips
- round knife
- Satin nickel plated with black point tip
- Handle non-roll multicomponent
- **CONTENT:** Cut: Cross 3x80-4x100-5,5x150 PH: PH0-PH1-PH2

Code	Description
4200100405	6-Series 6 screwdrivers Meccanocar

## 7 Series screwdrivers Meccanocar Big Cut, Cross Phillips and Pozidriv supporting Mecrack



- Per viti a Taglio-croce Phillips
- Lama rotonda
- Nichelato opaco con punta black point
- Impugnatura anti-rotolamento multicomponente
- **CONTENUTO:** Taglio: 5,5x150-6x125-8x175-10x200 ; Croce PH: PH1-PH2 Pozidriv PZ: PZ3

Code	Description
4200100410	7-series 7 screwdrivers Meccanocar Big

## Series 7 Torx screwdrivers Meccanocar supporting Mecrack



- For screws TORX
- round knife
- Satin nickel plated with black point tip
- Handle non-roll multicomponent
- **CONTENT:** Torx: TX10-TX15-TX20-TX25-TX27-TX30-TX40

Code	Description
4200100415	7 / Torx-7 series Meccanocar Torx screwdrivers

## 7 Series screwdrivers VDE electricians supporting Mecrack



- For slotted screws and Phillips
- round knife
- Satin nickel plated with black point tip
- Handle non-roll multicomponent
- **CONTENT:** Cut: 2,5x80 3x100-VDE VDE-3,5x100 VDE 4x100-VDE-5,5x125 VDE; Cross PH: PH1 VDE-PH 2 VDE

Code	Description
4200100420	7 / VDE-7 series screwdrivers VDE Meccanocar

## Magnetizer Star

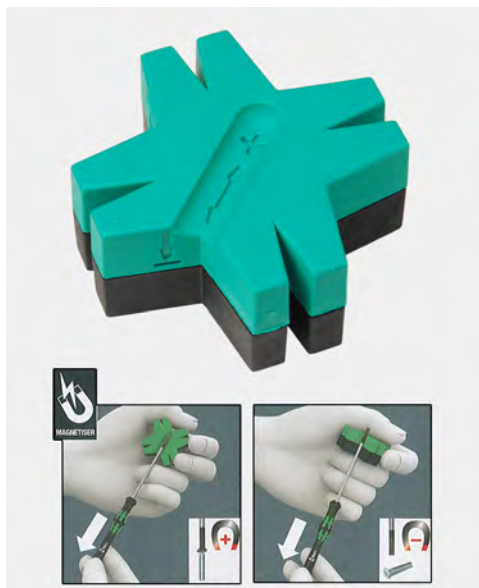

- Just slide the tip of the screwdriver Meccanocar along side "positively charged" to load the tip of positive magnetic, the screw will not come off from the tip of the screwdriver
- To demagnetize the screwdriver, just slide the screwdriver Meccanocar along the "downside"

Code	Description	Diameter mm
4200100425	magnetizer Star	48 mm

## Support for screwdrivers Meccanocar "MECRACK"



- Support 7 screwdrivers Meccanocar with positioning is on the workbench is to the wall or pegboard.

Code	Description	L. x P.
4200100430	Mecrack-support	190 mm x 50 mm

## Keys to handle "T" Meccanocar

- Particularly appreciated and used when you want to have a key that transmits high torques and loosening.
- The ergonomic shape allows a perfect grip, the whole hand is in contact with the handle, and then there is no loss by friction between the hand and the handle.
- Exclusive patent Wera called "HEX-PLUS", which allows you to have a perfect angle of contact in the screw head, considerably reducing the risk of lives damaged or rounded.

## Wrench screwdriver with handle "T" Allen



- Per viti a esagono cavo
- Lama esagonale
- Hex-Plus smussato nichelato opaco
- Impugnatura a "T" monocomponente

Code	Desc.	Imprint	Length blade	Handle Height	Lunghezza manico
4200100435	454-2	2	100 mm	27 mm	61 mm
4200100440	454-2,5	2,5	100 mm	27 mm	61 mm
4200100445	454-3	3	100 mm	33 mm	70 mm
4200100450	454-4	4	150 mm	33 mm	70 mm
4200100455	454-5	5	150 mm	44 mm	87 mm
4200100460	454-6	6	200 mm	44 mm	87 mm
4200100465	454-8	8	200 mm	44 mm	87 mm
4200100470	454-10	10	200 mm	44 mm	87 mm

8

## Wrench screwdriver with handle "T" Torx



- For Torx socket
- round knife
- Matt nickel tipped Black Point
- Handle "T" single-component

Code	Desc.	Imprint	Length blade	Handle Height	Lunghezza manico
4200100475	467-TX10	Tx10	100 mm	27 mm	61 mm
4200100480	467-TX15	Tx15	100 mm	33 mm	61 mm
4200100485	467-TX20	Tx20	100 mm	33 mm	70 mm
4200100490	467-TX25	Tx25	100 mm	33 mm	70 mm
4200100495	467-TX27	Tx27	200 mm	44 mm	87 mm
4200100500	467-TX30	Tx30	200 mm	44 mm	87 mm
4200100505	467-TX40	Tx40	200 mm	44 mm	87 mm



## Wrench screwdriver with handle "T" socket



- For Torx socket
- round knife
- Matt nickel tipped Black Point
- Handle "T" single-component

Code	Desc.	Wrench <i>socket wrench</i>	Length <i>blade</i>	Handle Height	Lunghezza manico	Ø est. <i>bussola</i>
4200100510	495-7	7	230 mm	44 mm	87 mm	11,00 mm
4200100515	495-8	8	230 mm	44 mm	87 mm	12,10 mm
4200100520	495-10	10	230 mm	44 mm	87 mm	14,10 mm
4200100525	495-13	13	230 mm	44 mm	87 mm	18,10 mm

## Series Keys to handle "T" Meccanocar

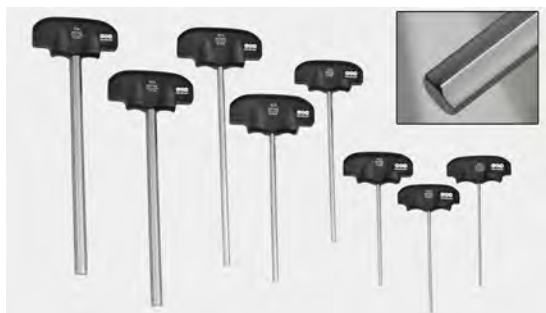

- Impugnatura a "T" monocomponente

Code	Description	Content
4200100530	8-ES Series hex keys a T 8 pieces	2-2,5-3-4-5-6-8-10

## Series Keys to handle "T" Meccanocar Torx



- Impugnatura a "T" monocomponente

Code	Description	Content
4200100535	7/Torx Serie chiavi a T Torx 7 pezzi	Tx:10-15-20-25-27-30-40

## Series blades double VARIO



- Produced in the same tough material hard inserts and therefore high durability.
- tip with high corrosion protection
- **CONTENT 4200100540:**
- 1 handle to blade;
- 1 4 + 6x175-cut cod. 4430056050; 1 cut-5 + 7x175
- 1-hex 4x175 cod. 4430056060; 1-hex 5x175 cod. 4430056065; 1-hex 6x175 cod. 4430056070
- 1-ph1 + ph2x175 cod. 4430056035
- 1-PZ1 + pz2x175 cod. 4430056040
- 1-tx10 + tx15x175 cod. 4430056075; 1-TX20 + tx25x175 cod. 4430056080; 1-TX30 + tx40x175 cod. 4430056085
- **CONTENT 4200100545:** Hexagon 6mm hex nut-key 10-mm handle length 98 mm

Code	Description
4200100540	88/1 Assortment-blades grip Vario + 11 pieces 88/1 Assortment-blades grip Vario + 11 pieces
4200100545	80-blade screwdriver handle Vario

8

## Hexagonal socket screwdriver



- Acetate handle
- Chrome-vanadium steel shaft
- In accordance with the DIN 3125 standard
- For use by mechanics, electricians, installers, etc.

Code	Descr. / misura bocca	Length handle + shaft mm
4200068040	68040-4	102+80
4200068050	68050-5	102+80
4200068055	68055-5,5	102+80
4200068060	68060-6	102+80
4200068070	68070-7	102+80
4200068080	68080-8	102+80
4200068090	68090-9	102+80
4200068100	68100-10	114+80
4200068110	68110-11	114+80
4200068120	68120-12	114+80
4200068130	68130-13	114+80

## Percussion screwdriver



- To remove particularly resistant screws and screw hinges goalkeeper.
- A switch for rotation right or left hand.
- Bushing 1/2" and hexagon bits for 5/16"
- Complete No.1 bits PH2; PH3, No.1 blade bits M9; M11.

Code	Desc.
4430026800	334

## Tough inserts for hard metals such as tin, iron, metal in general, with attack by 1 / 4-5 / 16 and 3/8.

**Inserts:** thanks to their profiles with precise geometries and their perfect concentricity, inserts Meccanocar ensure safe working and a long service life of the tool. The composition of the steel content in the inserts is Meccanocar tenacious hard. Meccanocar inserts are designed for use in industry and trade. Allow to transmit high torques and last long.

### Hexagon bits 1/4" (6.35)



- Imprint screwdriver.
- UNI ISO 2351.

Code	Desc.	Ø x spess. mm	L mm
4430025100	317-3	3x0,5	25
4430025110	317-4	4x0,6	25
4430025130	317-5	5x0,8	25
4430025150	317-6	6x1	25
4430025170	317-8	8x1,2	25

### Hexagonal shank bits 1/4" (6.35)



- Phillips cross recess.
- UNI 7080-72.

Code	Desc.	Imprint n.	L mm
4430025200	318-1	PH1	25
4430025210	318-2	PH2	25
4430025220	318-3	PH3	25

### Hexagonal shank bits 1/4" (6.35)



- Pozidriv imprint.

Code	Desc.	Imprint n.	L mm
4430046620	737-1	PZ. 1	25
4430046622	737-2	PZ. 2	25
4430046624	737-3	PZ. 3	25
4430046625	737-4	PZ. 4	32

### Hexagonal shank bits 1/4" (6.35)



- Bits 1/4" hexagonal (6.35).
- Cross recess Phillips.
- Tip knurled ACR.
- The tip acr allows a secure grip of the screw avoiding spillage during work.

Code	Desc.	Imprint n.	L mm
4430025230	318-1 ACR	PH 1	25
4430025235	318-2 ACR	PH 2	25

## Hexagonal shank bits 1/4" (6.35)



- Hexagonal male.
- UNI-ISO 3109.

Code	Desc.	Measure mm	L mm
4430046676	744-2	2	25
4430046678	744-2,5	2,5	25
4430046680	744-3	3	25
4430046682	744-4	4	25
4430046684	744-5	5	25
4430046686	744-6	6	25
4430046690	744-8	8	25
4430046692	744-10	10	25

## Hexagonal shank bits 1/4" (6.35)



Code	Desc.	Imprint n.	L mm
4430046742	749Tx6	Tx6	25
4430046744	749Tx7	Tx7	25
4430046746	749Tx8	Tx8	25
4430046748	749Tx9	Tx9	25
4430046750	749Tx10	Tx10	25
4430046752	749Tx15	Tx15	25
4430046754	749Tx20	Tx20	25
4430046756	749Tx25	Tx25	25
4430046758	749Tx27	Tx27	25
4430046760	749Tx30	Tx30	25
4430046762	749Tx40	Tx40	25
4430046764	749Tx45	Tx45	25
4430046766	749Tx50	Tx50	25

- imprint Torx male.

## Hexagonal shank bits 1/4" (6.35)



- Bits Hex attack. 1/4" (6.35).
- Hexagonal with hole.

Code	Desc.	Imprint n.	L mm
4430050860	1025-2	2	25
4430050862	1025-2,5	2,5	25
4430050864	1025-3	3	25
4430050866	1025-4	4	25
4430050868	1025-5	5	25
4430050870	1025-6	6	25



## Hexagonal shank bits 1/4" (6.35)



- imprint Torx male with hole.

Code	Desc.	Imprint n.	L mm
4430046770	750Tx10	Tx10	25
4430046772	750Tx15	Tx15	25
4430046774	750Tx20	Tx20	25
4430046776	750Tx25	Tx25	25
4430046778	750Tx27	Tx27	25
4430046780	750Tx30	Tx30	25
4430046782	750Tx40	Tx40	25

## Hexagonal shank bits 1/4" (6.35)

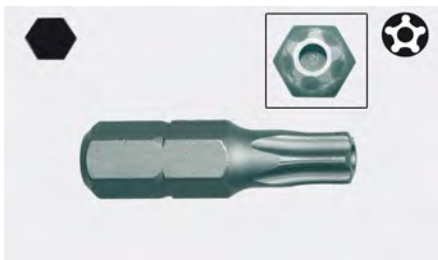

- Bits Hex attack. 1/4" (6.35).
- imprint Torx 5-pointed star c / guide hole.

Code	Desc.	Imprint n.	L mm
4770002832	283-TS15	TS15	25
4770002833	283-TS20	TS20	25
4770002834	283-TS25	TS25	25
4770002835	283-TS27	TS27	25
4770002836	283-TS30	TS30	25
4770002837	283-TS40	TS40	25

8

## Tips for pneumatic screwdriver 1/4" hexagonal (6.35) with throat



- Phillips cross recess.

Code	Desc.	Imprint n.	L mm
4430046590	734-1	PH 1	50
4430046592	734-2	PH 2	50
4430046594	734-3	PH 3	50
4430046596	734L-1	PH 1	75
4430046598	734L-2	PH 2	75
4430046600	734L-3	PH 3	75

## Bits extra long 1/4" hexagonal (6.35) with throat



- Bits 1/4" hexagonal (6.35) with throat.
- For the direct use of pneumatic screwdrivers and wrenches.
- Phillips imprint.
- **Execution milled extra long.**

Code	Desc.	Imprint n.	L mm
4430046603	734 XL-1	PH 1	100
4430046605	734 XL-2	PH 2	100
4430046607	734 XL-3	PH 3	100

## Tips for pneumatic screwdrivers Hexagonal shank 1/4" (6.35) with throat imprint Phillips

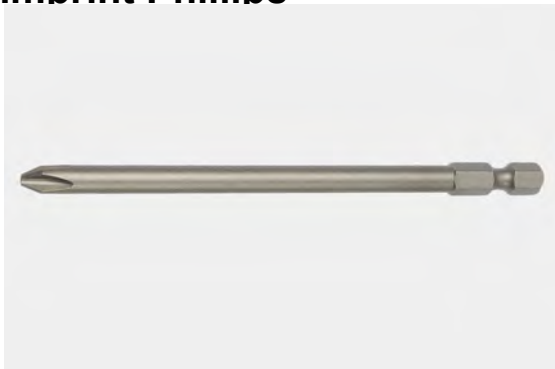

- For Phillips screws
- For hard metals
- DIN 3126 ISO 1173

Code	Desc.	Imprint n.	L mm
4430057100	851/4 Z-PH1-89	PH1	89 mm
4430057105	851/4 Z-PH1-152	PH1	152 mm
4430057110	851/4 Z-PH2-70	PH2	70 mm
4430057115	851/4 Z-PH2-110	PH2	110 mm
4430057120	851/4 Z-PH2-127	PH2	127 mm
4430057125	851/4 Z-PH2-152	PH2	152 mm
4430057130	851/4 Z-PH3-89	PH3	89 mm
4430057135	851/4 Z-PH3-152	PH3	152 mm

## Tips for pneumatic screwdriver 1/4 "hexagonal (6.35) with throat



- Imprint Torx male.

Code	Desc.	Imprint n.	L mm
4430046784	751TX-T10	Tx10	50
4430046786	751TX-T15	Tx15	50
4430046788	751TX-T20	Tx20	50
4430046790	751TX-T25	Tx25	50
4430046792	751TX-T27	Tx27	50
4430046794	751TX-T30	Tx30	50
4430046796	751TX-T40	Tx40	50

## Tips for pneumatic screwdriver 1/4 "hexagonal (6.35) with throat



- Imprint Torx male with hole.

Code	Desc.	Imprint n.	L mm
4430046608	735TX-T10	Tx10	50
4430046610	735TX-T15	Tx15	50
4430046612	735TX-T20	Tx20	50
4430046614	735TX-T25	Tx25	50
4430046616	735TX-T27	Tx27	50
4430046618	735TX-T30	Tx30	50
4430046619	735TX-T40	Tx40	50

## Bits 1/4" hexagonal (6.35) with throat



Code	Desc.	Imprint n.	L mm
4430050842	1024-2	2	70
4430050844	1024-2,5	2,5	70
4430050846	1024-3	3	70
4430050848	1024-4	4	70
4430050850	1024-5	5	70
4430050852	1024-6	6	70
4430050854	1024-7	7	70
4430050856	1024-8	8	70
4430050858	1024-10	10	70

- Bits 1/4" hexagonal (6.35) with throat.
- For the direct use of pneumatic screwdrivers and wrenches.
- Hexagonal male.
- **Running milled extra long.**

## Tips for double pneumatic screwdriver 1/4 "hexagonal (6.35)



- Cross recess Phillips.

Code	Desc.	Imprint n.	L mm
4430011400	217-1	PH 1	75
4430011500	218-2	PH 2	75
4430011600	219-3	PH 3	75

8

## Compasses for hex head screws 1/4" (6.35)



- Compasses for direct use of screwdrivers with female coupling 1/4".
- Internal magnet for retaining the screw during work.

Code	Desc.	Mis. chiave	Attachment	L mm
4430044684	509-5,5	5,5	1/4	50
4430044685	509-6	6	1/4	50
4430044686	509-8	8	1/4	50
4430044687	509-7	7	1/4	50
4430044688	509-10	10	1/4	50
4430044689	509-12	12	1/4	50
4430044690	509-13	13	1/4	50

## Bits Hexagonal shank 5/16" (7.94)



- Imprint screwdriver.
- UNI-ISO 2351.

Code	Desc.	Ø x spess. mm	L mm
4430025300	319-6	6x1	41
4430025310	319-7	7x1,2	41
4430025320	319-8	8x1,2	41
4430025340	319-10	10x1,6	41
4430025350	319-12	12x2	41

### Bits Hexagonal shank 5/16" (7.94)



- Phillips cross recess.
- UNI 7080-72.

Code	Desc.	Imprint n.	L mm
4430025400	320-1	PH 1	35
4430025410	320-2	PH 2	35
4430025420	320-3	PH 3	35
4430025430	320-4	PH 4	35

### Bits Hexagonal shank 5/16" (7.94)



- Imprint Torx male.

Code	Desc.	Imprint n.	L mm
4430045430	586-T20	Tx20	35
4430045435	586-T25	Tx25	35
4430045440	586-T27	Tx27	35
4430045445	586-T30	Tx30	35
4430045450	586-T40	Tx40	35
4430045455	586-T45	Tx45	35
4430045460	586-T50	Tx50	35
4430045465	586-T55	Tx55	35

### Hexagonal shank bits 3/8" (9,52)



- Hexagonal imprint male.

Code	Desc.	Measure mm	L mm
4430042510	475-4	4	30
4430042520	475-5	5	30
4430042530	475-6	6	30
4430042540	475-7	7	30
4430042550	475-8	8	30
4430042560	475-10	10	30
4430042570	475-12	12	30

### Hexagonal shank bits 3/8" (9,52)



- Hexagonal imprint male long.

Code	Desc.	Measure mm	L mm
4430042574	475L-4	4	75
4430042575	475L-5	5	75
4430042580	475L-6	6	75
4430042582	475L-7	7	75
4430042585	475L-8	8	75
4430042590	475L-10	10	75
4430042592	475L-12	12	75



## Hexagonal shank bits 3/8" (9,52)



- imprint Torx male.

Code	Desc.	Imprint n.	L mm
4430044400	491-T20	Tx20	30
4430044401	491-T25	Tx25	30
4430044390	491-T27	Tx27	30
4430044402	491-T30	Tx30	30
4430044403	491-T40	Tx40	30
4430044404	491-T45	Tx45	30
4430044405	491-T50	Tx50	30
4430044406	491-T55	Tx55	30

## Hexagonal shank bits 3/8" (9,52)



- imprint Torx male long.

Code	Desc.	Imprint n.	L mm
4430044310	491L-T20	Tx20	75
4430044312	491L-T25	Tx25	75
4430044314	491L-T27	Tx27	75
4430044316	491L-T30	Tx30	75
4430044318	491L-T40	Tx40	75
4430044320	491L-T45	Tx45	75
4430044322	491L-T50	Tx50	75
4430044324	491L-T55	Tx55	75

8

## Hexagonal shank bits 3/8" (9,52)



- imprint Torx male with hole.

Code	Desc.	Imprint n.	L mm
4430046800	752-T10	Tx10	30
4430046802	752-T15	Tx15	30
4430046804	752-T20	Tx20	30
4430046806	752-T25	Tx25	30
4430046808	752-T27	Tx27	30
4430046810	752-T30	Tx30	30
4430046812	752-T40	Tx40	30
4430046814	752-T45	Tx45	30
4430046816	752-T50	Tx50	30
4430046818	752-T55	Tx55	30

## Hexagonal shank bits 3/8" (9,52)



- imprint Torx male with long hole.

Code	Desc.	Imprint n.	L mm
4430046820	753-T10	Tx10	75
4430046821	753-T15	Tx15	75
4430046822	753-T20	Tx20	75
4430046823	753-T25	Tx25	75
4430046824	753-T27	Tx27	75
4430046826	753-T30	Tx30	75
4430046828	753-T40	Tx40	75
4430046830	753-T45	Tx45	75
4430046832	753-T50	Tx50	75
4430046834	753-T55	Tx55	75



## Hexagonal shank bits 3/8" (9,52)



- imprint XZN multi grooved.

Code	Desc.	Dimensions mm	L mm
4430044480	499-5	M 5	30
4430044490	499-6	M 6	30
4430044500	499-8	M 8	30
4430044510	499-10	M 10	30
4430044520	499-12	M 12	30

## Hexagonal shank bits 3/8 "(9,52)

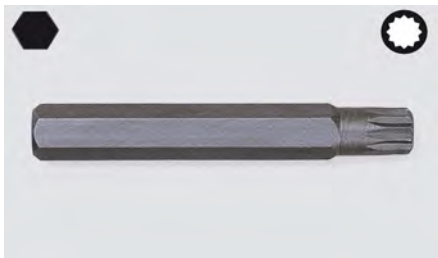

- imprint multi-grooved XZN long.

Code	Desc.	Dimensions mm	L mm
4430044528	500-5	M 5	75
4430044530	500-6	M 6	75
4430044540	500-8	M 8	75
4430044550	500-10	M 10	75
4430044560	500-12	M 12	75

## inserts TIN

- Inserts TIN: special treatment to the titanium nitride. It is a very hard coating that is capable of withstanding continuous therefore very suitable during multiple screw connections.
- With 1/4 "hex.

## Hexagonal shank bits 1/4" (6.35)



- Bits 1/4" hexagonal (6.35).
- Cross recess Phillips.
- With protective coating titanium nitride (TIN).
- The tin coating guarantees a greater hardness of bits and therefore a longer life of the tool.

Code	Desc.	Imprint n.	L mm
4430025240	318-1 TIN	PH 1	25
4430025245	318-2 TIN	PH 2	25
4430025250	318-3 TIN	PH 3	25

## Hexagonal shank bits 1/4" (6.35)



- Bits 1/4" hexagonal (6.35).
- Cross recess pozidrive.
- With protective coating titanium nitride (TIN).
- The tin coating guarantees a greater hardness of bits and therefore a longer life of the tool.

Code	Desc.	Imprint n.	L mm
4430046630	737-1 TIN	PZ 1	25
4430046632	737-2 TIN	PZ 2	25
4430046634	737-3 TIN	PZ 3	25

## Bits 1/4 "hexagonal (6.35) with throat



- Bits 1/4" hexagonal (6.35) with throat.
- For the direct use of pneumatic screwdrivers and wrenches.
- Phillips footprint.
- With protective coating titanium nitride (TIN).
- The tin coating guarantees a greater hardness of bits and therefore a longer life of the tool.

Code	Desc.	Imprint n.	L mm
4430046570	734-1 TIN	PH 1	50
4430046572	734-2 TIN	PH 2	50
4430046574	734-3 TIN	PH 3	50

8

## Bits 1/4" hexagonal (6.35) with throat



- Bits 1/4" hexagonal (6.35) with throat.
- For the direct use of pneumatic screwdrivers and wrenches.
- Pozidrive footprint.
- With protective coating titanium nitride (TIN).
- The tin coating guarantees a greater hardness of bits and therefore a longer life of the tool.

Code	Desc.	Imprint n.	L mm
4430046660	741-1 TIN	PZ 1	50
4430046662	741-2 TIN	PZ 2	50
4430046664	741-3 TIN	PZ 3	50

## Inserts BTH BITORSION

- Have a torsion zone thermally treated which allows to reduce the hardness of the stem of 20% and increasing the elasticity compared to that of the tip. In this way it prevents at high loads the tip of the insert is damaged, it extends the life of the bit.
- Particularly suitable for mounts multiple and for soft materials such as wood.
- With 1/4" hex.

### Inserts BTH BITORSION Hexagonal shank 1/4" (6,35) footprint Phillips



- For Phillips screws
- For soft materials such as wood
- DIN 3126 ISO 1173

Code	Desc.	Imprint n.	L mm
4430057140	851/1 BTH-PH1-25	PH1	25mm
4430057145	851/1 BTH-PH2-25	PH2	25 mm
4430057150	851/1 BTH-PH3-25	PH3	25 mm

### Inserts BTH BITORSION Hexagonal shank 1/4" (6,35) footprint Phillips throat



- For Phillips screws
- For soft materials such as wood
- DIN 3126 ISO 1173

Code	Desc.	Imprint n.	L mm
4430057155	851/4 BTH-PH1	PH1-con gola	50 mm
4430057160	851/4 BTH-PH2	PH2-con gola	50 mm
4430057165	851/4 BTH-PH3	PH3-con gola	50 mm

### Inserts BTH BITORSION Hexagonal shank 1/4" (6,35) imprint Pozidriv



- Screw Pozidriv
- For soft materials such as wood
- DIN 3126 ISO 1173
- **Specific for wood**

Code	Desc.	Imprint n.	L mm
4430057170	855/1 BTH-PZ1	PZ1	25mm
4430057175	855/1 BTH-PZ2	PZ2	25mm
4430057180	855/1 BTH-PZ3	PZ3	25mm

## Inserts BTH BITORSION Hexagonal shank 1/4" (6,35) footprint with Pozidriv throat



- Screw Pozidriv
- For soft materials such as wood
- DIN 3126 ISO 1173

Code	Desc.	Imprint n.	L mm
4430057185	855/4 BTH PZ1	PZ1	50 mm
4430057190	855/4 BTH PZ2	PZ2	50 mm
4430057195	855/4 BTH PZ3	PZ3	50 mm

## Inserts in stainless steel

- Using stainless steel inserts, which prevent the formation of rust on the screws or on stainless steel surfaces. Improper rust stainless steel is formed by metal shavings issued by non-stainless steel utensils. They are deposited on the workpiece surface and with the principle of oxidation become rust.
- With 1/4" hex.

## Stainless steel inserts Hexagonal shank 1/4" (6.35) for Phillips screws imprint



- For Phillips cross screws
- Metal stainless steel
- With system TORSION
- DIN 3126 ISO 1173

Code	Desc.	Imprint n.	L mm
4430057200	3851/1 TS-PH1	PH1	25 mm
4430057205	3851/1 TS-PH2	PH2	25 mm
4430057210	3851/1 TS-PH3	PH3	25 mm

## Stainless steel inserts Hexagonal shank 1/4" (6.35) for screws Pozidriv imprint



- For cross Pozidriv screw
- Metal stainless steel
- With system TORSION
- DIN 3126 ISO 1173

Code	Desc.	Imprint n.	L mm
4430057215	3855/1 TS-PZ1	PZ1	25 mm
4430057220	3855/1 TS-PZ2	PZ2	25 mm
4430057225	3855/1 TS-PZ3	PZ3	25 mm

## Stainless steel inserts attack Torx ¼" (6.35) for Torx screws



- For Phillips head screws Torx
- Metal stainless steel
- With system TORSION
- DIN 3126 ISO 1173

Code	Desc.	Imprint n.	L mm
4430057230	3867/1 TS-TX10	Tx10	25 mm
4430057235	3867/1 TS-TX15	Tx15	25 mm
4430057240	3867/1 TS-TX20	Tx20	25 mm
4430057245	3867/1 TS-TX25	Tx25	25 mm
4430057250	3867/1 TS-TX27	Tx27	25 mm
4430057255	3867/1 TS-TX30	Tx30	25 mm
4430057260	3867/1 TS-TX40	Tx40	25 mm

## inserts IMPAKTOR

- They are used when it uses an impact wrench or hammer mechanism. These inserts are designed specifically to withstand the high forces of screwdrivers is to impact both percussion and all DIAMOND.
- With ¼" hex.

## Inserts IMPAKTOR ¼" (6.35) for hexagon bolts imprint incassato. Specifici for impact wrenches / percussion



- For hexagon socket screws
- DIN 3126 ISO 1173
- For impact wrenches / percussion
- Coated rough diamond on the tip to prevent slippage of the screw tip.

Code	Desc.	Imprint n.	L mm
4430057265	840/1 IMP DC 4	4,00	25 mm
4430057270	840/1 IMP DC 5	5,00	25 mm
4430057275	840/1 IMP DC 6	6,00	25 mm

## Inserts IMPAKTOR ¼ "(6.35) for Phillips screws imprint. Specific impact wrenches / percussion



- For Phillips screws
- DIN 3126 ISO 1173
- For impact wrenches / percussion
- Coated rough diamond on the tip to prevent slippage of the screw tip.

Code	Desc.	Imprint n.	L mm
4430057280	851/1 IMP DC PH2	PH2	25 mm
4430057285			



## Inserts IMPAKTOR 1/4"(6.35) for Torx screws. Specific impact wrenches / percussion



- For Phillips cross screws
- DIN 3126 ISO 1173
- For impact wrenches / percussion
- Coated rough diamond on the tip to prevent slippage of the screw tip.

Code	Desc.	Imprint n.	L mm
4430057290	867/1 IMP DC TX25	TX25	25 mm
4430057295	867/1 IMP DC TX30	TX30	25 mm
4430057300	867/1 IMP DC TX40	TX40	25 mm

## Brings bits 1/4 "hexagonal magnetic



- Screwdriver with 1/4" hexagonal magnetic.
- Bi-material ergonomic handle grip.

Code	Desc.	L mm
4200096351	P.BITS 1/4"	220

## Flexible screwdriver bits port 1/4" hexagonal magnetic



- Handle in cellulose acetate.

Code	Desc.	L mm
4770000240	24	250

## Brings magnetic bits 1/4 "hexagonal



- Compass.
- Hexagonal with throat.

Code	Desc.	L mm
4430044640	504	75

## Brings bits



- Brings adjustable magnetic bits.
- The special ring ensures the seal of the screw in any position.
- The only port bits which guarantees the grip even with bits in shear.

Code	Desc.	Attachment	Length mm
4430050450	996	1/4	58

## Brings bits



- Brings bits quick release.
- For releasing the bits you need to move back the ring.

Code	Desc.	Attachment	Length mm
4430050820	1021	1/4	60

## Brings bits



- Brings magnetic bits.
- SDS-Plus.
- For hammers with percussion lock.

Code	Desc.	Attachment	Length mm
4430050840	1023	1/4	76

## Insert Holder 1/4 long hex 152 mm throat with Screwdriver



- For Hexagon 1/4" DIN 3126-C 6.3 (ISO 1173)
- With stainless steel body, retaining ring and powerful magnet

Code	Description	Length mm	Ø mm
4430057305	899/4/1 porta bits lungo	152 mm	10,5 mm

## Insert Holder 1/4 "quick-change" Rapidaptor "



### RAPIDAPTOR

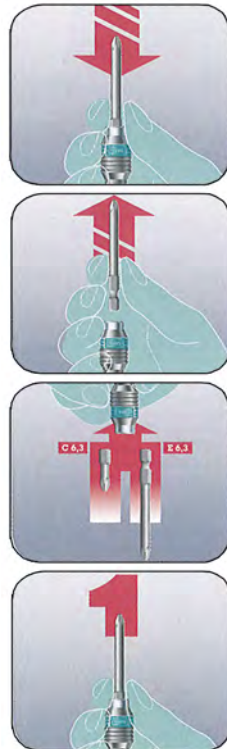

- For Hexagon 1/4 "DIN 3126-C 6.3 and E 6.3 (ISO 1173)
- With handle multicomponent anti-rolling

Code	Description	Length mm
4430057310	813 R-bit holder Rapidaptor	90 mm



## Screwdriver stock inserts and powerful magnet



- Per inserti esagonali da ¼" secondo DIN 3126-C 6,3 (ISO 1173)
- Con manico monocomponente anti-rotolamento
- Con potente magnete
- **Contenuto inserti:**
- 1 taglio 5,5x25
- 1 taglio 6,5x25
- 1 croce ph1x25
- 1 croce ph2x25
- 1 pozidriv pz1x25
- 1 pozidriv pz2x25



Code	Description	Lunghezza manico
4430057315	819/1/6-Screwdriver with magnet inserts	120 mm



8

## Bit holder ¼" hexagon blade and quick change



- For Hexagon ¼" DIN 3126-C 6.3 and E 6.3 (ISO 1173)
- With handle multicomponent anti-rolling
- With hexagonal blade with hex wrench and door inserts with quick change, powerful magnet

Code	Description	Lunghezza manico	Length blade
4430057320	829/4/1-bit holder Allen	98 mm	120 mm

## Adapters for socket wrenches



- Allow the use of all compasses with square.
- Hexagonal with throat 1/4".

Code	Desc.	Attachment esag.	Control panel attachment	Length mm
4430050830	1022-1/4-L50	1/4	1/4	50
4430050832	1022-1/4-L100	1/4	1/4	100
4430050834	1022-3/8-L50	1/4	3/8	50
4430050836	1022-3/8-L100	1/4	3/8	100
4430050838	1022-1/2-L50	1/4	1/2	50

## Compasses door bits



- Square drive input.
- Hexagon bits for output.
- \* With snap ring for retaining bits.

Code	Desc.	Control panel attachment "	Hexagonal attachment "	L mm
4430046902	761	1/4	1/4	26
4430046904	762	3/8	1/4	31
4430046906	763	3/8	5/16	34
4430046908	764	1/2	5/16	40
4430044570	501	1/2	3/8	36*
4430047806	835	3/8	3/8	36*



## Adapter reinforced female square 1/2" - female hexagon 1/4"



- Adapter inserts door reinforced with square for mass swing screwdrivers 1/2" and carries bits hexagonal 1/4". Designed for the use of inserts of screwdrivers with shaft bushings.
- Used on a low power for the screwing of screws swing and tires to ground screwdrivers with any kind of impression, especially in the field of carpentry fittings and fixtures, maintenance, plant, etc...
- Made of burnished steel, with spring-loaded locking sleeve against the bits of the spill.
- **WE RECOMMEND THE USE OF OUR SERIES IMPAKTOR BITS**



Code	Desc.
417RC15900	1204

## Insert Kit Torx Star



PARTICOLARE DELLA PUNTA DEL BITS CON IL FORO



MERCEDES (ATEGO, ACTROS)



ESEMPIO DI UTILIZZO SU DEBIMETRO



CORRISPONDENZA DELLE MIS. IN MM

TS10	2,5
TS15	3
TS20	3,5
TS25	4
TS27	4,7
TS30	5,2
TS40	6,2



- Inserts with 5 points with a central hole.
- New impression for safety screws.
- This imprint can be found on screws mounted pumps Bosch, the flow meter alpha 147, Nissan, Peugeot, Rover, Renault and on some vehicles, see: Mercedes Atego, Actros
- Usable with door bits att. hexagonal 1/4 or 1/4 square drive tools and door inserts contained in the kit.
- Particularly suitable for workshops, bodywork, elettrauto etc ..
- **See spare parts list.**

Code	Desc.	Content
4770002830	283	1 PCS. TS10, TS15, TS20, TS25, TS27, TS30, TS40 1 PORTA BITS ATT. 1/4

8

## Series hex bits 1/4"



- In a plastic case with transparent lid.

CONTENUTO			
N°1PZ.	PH0x25	N°1PZ.	3x0,5x25
N°1PZ.	PH1x25	N°1PZ.	4x0,6x25
N°1PZ.	PH2x25	N°1PZ.	5x0,8x25
N°1PZ.	PH3x25	N°1PZ.	6x1,0x25
		N°1PZ.	7x1,0x25
N°1PZ.	PZD0x25	N°1PZ.	TX10x25
N°1PZ.	PZD1x25	N°1PZ.	TX15x25
N°1PZ.	PZD2x25	N°1PZ.	TX20x25
N°1PZ.	PZD3x25		
N°1PZ.	Ch.2x25		
N°1PZ.	Ch.3x25		
N°1PZ.	Ch.4x25		
N°1PZ.	Ch.5x25		

Code	Description
4430046880	758 - SERIES 20 PIECES



## Brings bits aL "1/4" hexagonal magnetic



- Hexagon with magnet in the long arm - with spring on the short arm.
- Coated cellulose acetate.

Code	Desc.	L mm
4430046840	755	110

## Insert Holder 1/4" hexagonal



- Practical door inserts shock-absorbing material.
- With belt clip.
- With docking port bits for our art. 443 443 00 00 46840-755 and 44640-504.

Code	Desc.
4430046838	754

## Series bits with bits leads to "L" 1/4 "hexagonal



- Series with case brings bits n / s art. 443 46838-754 and 00-bit port to "L" our art. 443 00 46840-755.

Code	Desc.	Content
4430046846	756 CR	PH0; PH1; PH2; PH3 PZ-1; PZ-2
4430046850	756 ES	Ch. mm2; 2,5; 3; 4; 5; 6
4430046852	756 TX	TX10; TX15; TX20; TX25; TX27; TX30

## Series bits with magnetic door bits 1/4 "hexagonal



- Series with case brings bits our art. 443 00 46838 to 754 and brings our art magnetic bits. 443 00 44640-504.

Code	Desc.	Content
4430046870	757 CR	PH0; PH1; PH2; PH3 PZ-1; PZ-2
4430046872	757 ES	Ch. mm2; 2,5; 3; 4; 5; 6
4430046874	757 TX	TX10; TX15; TX20; TX25; TX27; TX30



## Assortment compact 1/4" meckompakt 10 pieces



- For Hexagon 1/4" DIN 3126-C 6.3 and E 6.3 (ISO 1173)
- 10 pieces
- **CONTENT:**
- 1 cut 4x25
- 1 cut 5,5x25
- 1 cross ph1x25
- 1 cross ph2x25
- 1 pozidriv pz1x25
- 1 pozidriv pz2x25
- 1 Torx 10x25
- 1 Torx 15x25
- 1 Torx 20x25
- 1 door inserts Rapidaptor

Code	Description
4430057325	Kompakt 10-compact assortment 10 pieces

## Assortment 1/4 "32 pieces meckompakt



- For Hexagon 1/4" DIN 3126-C 6.3 and E 6.3 (ISO 1173)
- 32 pieces
- **CONTENT:**
- 1 cut 4x25; 1 cut 5,5x25; 1 cut 6,5x25
- 3 cross ph1x25; 3croce ph2x25; 3 cross ph3x25
- 3 pozidriv pz1x25; 3 pozidriv pz2x25; 3 pozidriv pz3x25
- 1 Torx with hole 10x25; 1 Torx with hole 15x25; 1 Torx with hole 20x25; 1 Torx with hole 25x25; 1 Torx with hole 30x25; 1 Torx with hole 40x25
- 1 hex 4x25; 1 hex 5x25; 1 hex 6x25
- 1 door inserts Rapidaptor
- 1 universal bit holder

Code	Description
4430057330	Kompakt 32-compact assortment 32 pieces

## Assortment compact 1/4 "inserted Impaktor screwdrivers 10 pieces



- 10 pieces
- For impact wrenches
- **CONTENT:**
- 1 cut 4x25
- 1 cut 5,0x25
- 1 cross ph2x25
- 1 cross ph3x25
- 1 pozidriv pz2x25
- 1 pozidriv pz3x25
- 1 Torx 25x25
- 1 Torx 30x25
- 1 Torx 40x25
- 1 port bits for Impakt

Code	Description
4430057335	IMP-8740 compact assortment 10 pieces Impakt

## Sets 14 bits with hexagonal shank 1/4"



- Colored Bits for a more rapid identification
- Door with magnetic Bits
- With two bits L70 with throat
- In practical folding carton

Code	Description	N. Pieces
4430057520	Kit 14 bits+carry bits 1/4	15

CONTENUTO	
+	1pc. PH1 - 1pc. PH2 - 1pc. PH3
+	1pc. PZ1 - 1pc. PZ2 - 1pc. PZ3
○	1pc. TX15 - 1pc. TX20 - 1pc. TX25
●	1pc. 4,5x0,6 - 1pc. 5,0x0,8 - 1pc. 6,5x1,2
+	1pc. PH2x70mm
+	1pc. PZ2x70mm



## Sets 32 bits with hexagonal shank 1/4"



- Colored Bits for a more rapid identification
- Carry with magnetic Bits
- With adapter 1/4+1/4
- With rear belt clip

Code	Description	N. Pieces
4430057530	Kit 32 bits+carry inserts	33

CONTENUTO	
+	1pc. PH1 - 2pcs. PH2 - 1pc. PH3
+	1pc. PZ1 - 2pcs. PZ2 - 1pc. PZ3
●	1pc. 3,0x0,5 - 1pc. 4,0x0,6 - 1pc. 5,5x0,8 - 1pc. 6,0x1,2
○	1pc. 3 - 1pc. 4 - 1pc. 5 - 1pc. 6
○	1pc. TX10 - 1pc. TX15 - 1pc. TX20 - 1pc. TX25 - 1pc. TX27 - 1pc. TX30 - 1pc. TX40
+	1pc. TXH10 - 1pc. TXH15 - 1pc. TXH20 - 1pc. TXH25 - 1pc. TXH27 - 1pc. TXH30 - 1pc. TXH40

portainseriti - bit holder



adattatore 1/4"C - 1/4"C adapter



## Deposit skewdriver with accessories 1/4" hexagonal



- With head bent to 90°, also mountable on battery or power tools.
- 45 pieces.

CONTENUTO	
<ul style="list-style-type: none"> <li>• N° 1 TESTA GIREVOLE AD ANGOLO</li> <li>• N° 1 PROLUNGA MAGNETICA 120mm</li> <li>• N° 1 PROLUNGA MAGNETICA 40mm</li> <li>• N° 1 IMPUGNATURA IN ACETATO</li> </ul>	
<ul style="list-style-type: none"> <li>⊕ IMPRONTA PHILLIPS: 0; 1; 2; 3</li> <li>⊖ IMPRONTA CACCIAVITE: 3,2; 4,8; 6,2; 8</li> <li>⊗ IMPRONTA TORX: T8; T9; T10; T15; T20; T25</li> <li>○ IMPRONTA ESAGONALE: 2-3/32-7/64-3-1/8-9/64-4-3/16-5</li> <li>● BUSSOLE TESTA ESAGONALE: 5; 5,5; 6; 1/4; 7; 8; 3/8; 9; 10</li> </ul>	

Code	Description
4770000710	71 - SERIES 45 PIECES

## Head parts for Screwdriver



- The head parts, thanks to special gear and particularly strong structure can be used in addition to the version screwdriver, even on electric screwdrivers and battery.
- The special lever adjustable contrast allows you to increase the torque.
- For heavy work and disassembly particular in places difficult to access with a special reference to 90th.
- For our cassette 477 00 00710-71.

Code	Desc.
4770000712	71/2

## screwdriver Skewdriver



- Screwdriver with tank containing No. 2 bits cut + 2 bits cross att.1 / 4 ".
- Resin head.
- Lever adjustable contrast for an increase in the tightening torque.
- Body only non removable.
- To work in places of difficult access.

Code	Desc.
4770000715	71/5



## Cover inserts and sockets 1/4 Grip bits folding door reversible

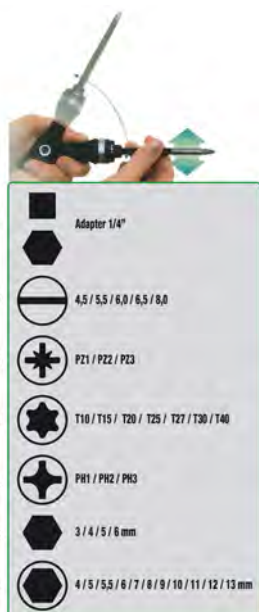

- Handy case containing 35 pcs.
- The handle can be used both upright and folded, with its ergonomicity 'makes almost' zero effort in screwing and unscrewing.
- Factory car / motorcycle installers.
- "Made in Germany" for a guarantee of quality.

Code	Desc.
4430056100	1622

CONTENUTO DEL KIT:		Rif.	
N°11 BUSSOLE ESAGONALI 1/4"	TIPO N/S ART. 42000	404C	7
N° 5 BITS A LAMA 1/4	TIPO N/S ART.44300	317	2
N° 3 BITS PZ 1/4	TIPO N/S ART.44300	737	3
N° 7 BITS TORX 1/4	TIPO N/S ART. 44300	749TX	4
N° 3 BITS PH 1/4	TIPO N/S ART. 44300	318	5
N° 4 BITS ESAG.1/4	TIPO N/S ART.44300	744	6
N° 1 ADATTATORE 1/4-1/4	ART.4430056110-1622/A		1
N° 1 IMPUGNATURA PIEGHEVOLE ATTACCO 1/4	ART.4430056105-1622/I		

## Series hex bits 3/8" with compass port bits. In metal box



- 15 bits 3/8" long 30mm.
- 12 bits 3/8" long 75mm.
- 1 compass leads bits 3/8" Q 2.1".

CONTENUTO
○ ESAGONALI 30mm: 4; 5; 6; 7; 8; 10; 12
○ ESAGONALI 75mm: 5; 6; 8; 10
○ XZN 30mm: 5; 6; 8; 10
○ XZN 75mm: 6; 8; 10; 12
⊗ TORX 30mm: T20; T25; T27; T30; T40; T45; T50; T55
N° 1 BUSSOLA PORTA BITS ATTACCO 1/2"

Code	Description
4430040870	40083 - SERIES 28 PIECES





## Series hex bits 3/8" with two compasses port bits. Plastic Housed



- 40 pieces.
- 19 bits 3/8" long 30mm.
- 19 bits 3/8" long 75mm.
- 1 compass leads bits 3/8" Q 3/8".
- 1 compass leads bits 3/8" Q 2.1".

CONTENUTO
○ ESAGONALI 30mm: 4; 5; 6; 7; 8; 10; 12mm
○ ESAGONALI 75mm: 4; 5; 6; 7; 8; 10; 12mm
○ XZN 30mm: 5; 6; 8; 10; 12
○ XZN 75mm: 5; 6; 8; 10; 12
⊕ TORX 30mm: T20; T25; T30; T40; T45; T50; T55
⊕ TORX 75mm: T20; T25; T30; T40; T45; T50; T55
N° 1 BUSSOLA PORTA BITS ATTACCO 3/8"
N° 1 BUSSOLA PORTA BITS ATTACCO 1/2"

Code	Description
4430040877	40087 - SERIES 40 PIECES

## Series Torx hex bits 3/8" pilot hole



- 22 pieces.
- 15 bits 3/8" long 30mm.
- 12 bits 3/8" long 75mm.
- 1 compass leads bits 3/8" Q 2.1".
- 1 compass brings bits 3/8" Q 3/8".

CONTENUTO
⊕ 10 BITS ATT. 3/8" L 30: T10; T15; T20; T25; T27; T30; T40; T45; T50; T55
⊕ 10 BITS ATT. 3/8" L 75: T10; T15; T20; T25; T27; T30; T40; T45; T50; T55
N° 1 BUSSOLA PORTA BITS Q 1/2"-ES 3/8"
N° 1 BUSSOLA PORTA BITS Q 3/8"-ES 3/8"

Code	Description
4430047772	818 - SERIES 22 PIECES

## Universal pliers



- Handles bimaterial (TPE).
- Satin chrome finish.
- Model to soft wire and hard.
- Cutting particularly long to round and flat cables with additional tempering up to 60 HRC.
- Special carbon steel.

Code	Desc.	L mm
4200041180	41-18	180
4200041200	41-20	200

## Flat-nosed pliers



- Knurled gripping surfaces.
- Handles bimaterial (TPE).
- Satin chrome finish.
- Tempering individual induction at high frequency.
- Special carbon steel.

Code	Desc.	L mm
4200005160	5-16	160

## Half-round nose pliers



- Knurled gripping surfaces.
- Handles bimaterial (TPE).
- Satin chrome finish.
- Sharp in induction hardening up to 60 HRC.
- Special carbon steel.

Code	Desc.	L mm
4200015160	15-16	160
4200015200	15-20	200

## Nose pliers half-round bent



- Knurled gripping surfaces.
- Tip that is bent at 45°.
- Handles bimaterial (TPE).
- Satin chrome finish.
- Sharp in induction hardening up to 60 HRC.
- Special carbon steel.

Code	Desc.	L mm
4200017160	17-16	160
4200017200	17-20	200

## Diagonal cutting nippers



- Handles bimaterial (TPE).
- Satin chrome finish.
- Model for soft wire and harmonious.
- Sharp precision with additional temperature up to 64HRC.
- Special carbon steel C60 resistant to fatigue.

Code	Desc.	L mm
4200029160	29-16	160

## Strong diagonal cutting nippers



- Handles bimaterial (TPE).
- Satin chrome finish.
- Model for soft wire and harmonious.
- Sharp precision with additional temperature up to 64HRC.
- Special carbon steel C60 resistant to fatigue.

Code	Desc.	L mm
4200033200	33-20	200

8

## Cutter strong in front cutting edge



- Handles bimaterial (TPE).
- Satin chrome finish.
- Model for soft wire and harmonious sharp precision with additional temperature up to 64 HRC.
- Special carbon steel, special remediation.

Code	Desc.	L mm
4200037160	37-16	160

## Cable cutter



- Handles bimaterial (TPE).
- Satin chrome finish.
- To cut copper and aluminum cables.
- Cutters additional induction hardening.
- Spring integrated and hidden.
- Adjustable hinge.
- With stop finger.
- High quality chrome vanadium steel.
- Particularly resistant to fatigue.

Code	Desc.	L mm	For cables mm <sup>2</sup>
4200047170	47-17	170	10/35
4200047230	47-23	230	17/50

## Combined pliers



- Caliper Combined multifunctional, special steel C60 high carbon content, which confers greater resistance and cutting ability.
- Intended Use: electricians, builders, maintainers, elettrauto, mechanical, etc.
- Handles bimaterial (TPE).
- The gripper presents: a cutting edge at the tip for clean cutting of electrical wires (A); 2 holes for stripping the insulation of the cable section of 1.5 mm and 2.5 mm (B); a wire cutter for cutting of materials also particularly hard (C); a crimp terminal to the tube section 1,5mm and 2,5 mm (D), two holes for clean cutting of metric screws M3.5 and M4 (particularly pointed out in the electrical sector) (E); side pin to create protective rings with internal diameter 4-5-6mm on wires of copper and iron particularly hard (F).
- The sloping shape of the gripper, allows the operator to work without fatigue even in confined spaces and difficult to reach, such as the inside of an electrical panel, engine compartment, etc ..

Code	Desc.	Length mm
4200098510	21-185	185

## Pinze extra lunghe



- Pliers extra long to special uses.
- Particularly suitable to working in confined spaces and difficult to reach, such as dashboards, engine compartment, etc.
- Special steel high strength.
- Resin handles slip.
- Overall length of pliers: 260 mm.

Code	Description
4770001210	121- series 3 pliers
4770001212	121D - extra-long nose pliers straight
4770001215	121M - extra-long nose pliers bent at 45
4770001217	121P - extra-long nose pliers bent 90 °



## Series pliers Meccanocar



- Handles bimaterial (TPE).
- Satin chrome finish.
- Special carbon steel resistant to fatigue.
- In practical case.

Code	Description
4200076260	76-260 - BIC - Series pliers Meccanocar



CONTENUTO	CODICE
Pinza universale	420 00 41180 - 41-18
Tronchese forte a tagliente frontale	420 00 37160 - 37-16
Pinza poligrip speedy	420 00 78250 - 78.25
Pinza a becchi mezzitondi piegati	420 00 17200 - 17-20
Tronchese a tagliente diagonale	420 00 29160 - 29-16
Pinza a becchi mezzitondi dritti	420 00 15200 - 15-20

## Universal pliers VDE / IEC 1000V

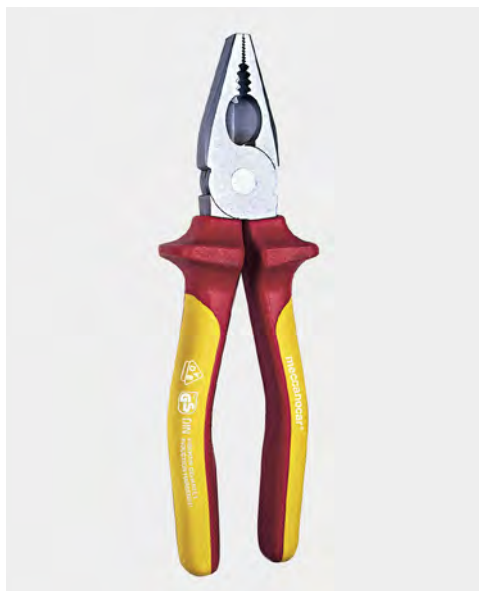

- Handles bimaterial (TPE) resistant to voltage 1000V AC (alternating) and 1500 VDC (continued) red and yellow colors to better identify the tools. Pursuant to work live.
- Resistance to temperature from -20 ° to + 70 °.
- Comply with VDE-GS-DIN IEC.
- Satin chrome finish.
- Model to soft wire and hard.
- Sharp especially hard to round and flat cables, with induction hardening up to 60 HRC.
- Special carbon steel.

Code	Desc.	L mm
4200041181	41.18VDE	180
4200041201	41.20VDE	200

## Half-round nose pliers VDE / IEC 1000V

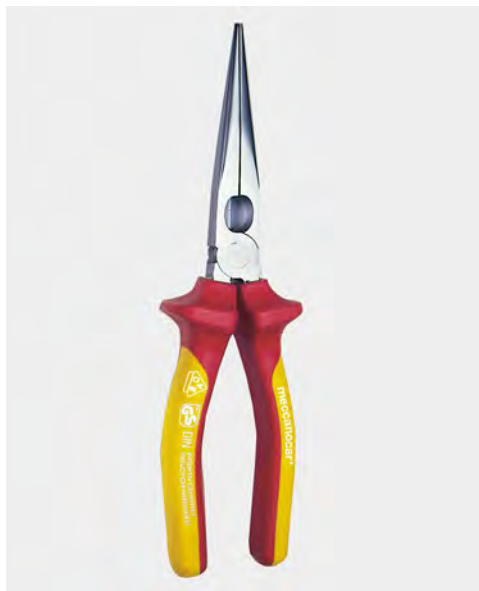

- Knurled gripping surfaces.
- Handles bimaterial (TPE) strains resistant to 1000 V AC (alternating) and 1500 VDC (continuous).
- Red and yellow colors for better tools to identify standards for work under voltage.
- Resistance to temperature -20 + 70.
- Comply with VDE-GS-DIN IEC.
- Satin chrome finish.
- Sharp in induction hardening up to 60 HRC.
- Special carbon steel.

Code	Desc.	L mm
4200015201	15.20 VDE	200



## Half-round nose pliers bent VDE / IEC 1000V



- Knurled gripping surfaces.
- Handles bimaterial (TPE) strains resistant to 1000 V AC (alternating) and 1500 VDC (continuous).
- Red and yellow colors for better tools to identify standards for work under voltage.
- Resistance to temperature -20 + 70.
- Comply with VDE-GS-DIN IEC.
- Satin chrome finish.
- Sharp in induction hardening up to 60 HRC.
- Special carbon steel.

Code	Desc.	L mm
4200017201	17-20VDE	200

## Diagonal cutting nippers VDE / IEC 1000V



- Handles bimaterial (TPE) resistant to voltage 1000V AC (alternating) and 1500 VDC (continuous).
- Red and yellow colors for better tools to identify standards for work under voltage.
- Resistance to temperature from -20 to +70.
- Comply with VDE-GS-DIN IEC.
- To cut hard wires and sweets.
- Satin chrome finish.
- Sharp in induction hardening up to 62 HRC.
- Special carbon steel.

Code	Desc.	L mm
4200028161	28.16 VDE	160

## Strong diagonal cutting nippers VDE / IEC 1000V

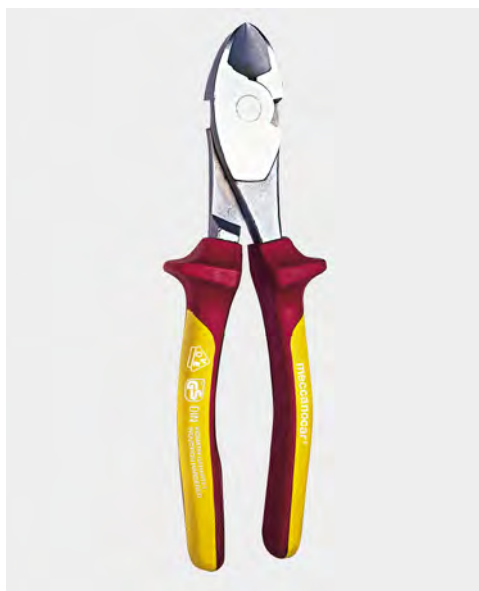

- Handles bimaterial (TPE).
- Resistant to voltage 1000V AC (alternating) and 1500VDC (continued).
- Red and yellow colors for better tools to identify standards for work under voltage.
- Temperature resistance from -20 ° + 700.
- Comply with VDE-GS-DIN IEC.
- For cutting soft wire and harmonious.
- Satin chrome finish.
- Sharp in induction hardening up to 64 HRC.
- Special carbon steel C60.

Code	Desc.	L mm
4200033201	33.20 VDE	200

## Cable cutter VDE / IEC 1000V



- Handles bimaterial (TPE).
- Resistant to voltage 1000V AC (alternating) and 1500 VDC (continuous).
- Red and yellow colors to better identify standards to work under voltage.
- Resistance to temperature from -20 ° to + 70 °.
- Comply with VDE-GS-DIN IEC.
- Satin chrome finish.
- Model with soft wire and hard.
- Cutting edge with additional induction hardening.
- Spring integrated and hidden.
- Adjustable hinge.
- With stop finger.
- High quality steel to crom-vanadium.
- Particularly resistant to fatigue.

Code	Desc.	L mm
4200047171	47-17VDE	170

## Combined pliers VDE / IEC 1000V

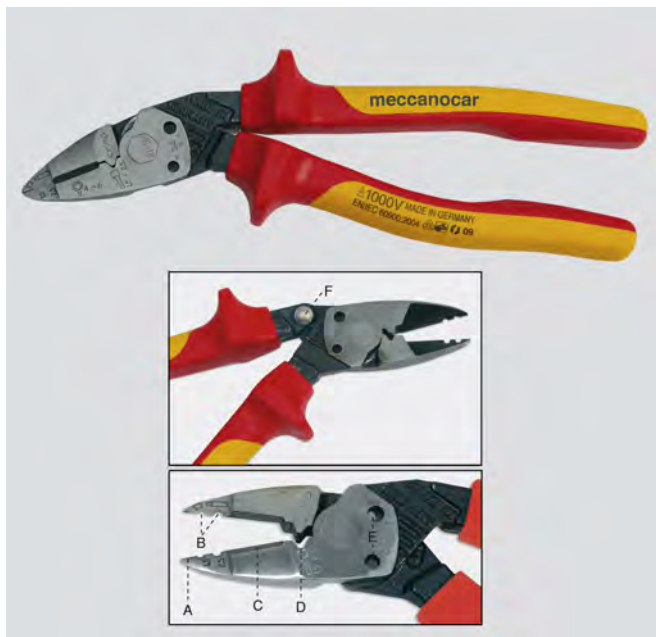

- Caliper Combined multifunctional, special steel C60 containing a high carbon content, which confers greater resistance and cutting ability.
- Intended Use: Electricians, panel builders, maintainers, elettrauto, mechanical, etc.
- Handles bimaterial (TPE) resistant to voltage 1000V ac (alternating) and 1500 Vdc (continued).
- Temperature resistant from -20 to + 70°C.
- Comply with VDE-GS-DIN IEC.
- The gripper presents: A sharp tip for clean cutting of electric wires (a); 2 holes for stripping the insulation of the cable section 1.5mm and 2.5mm (b); a wire cutter for cutting of materials also particularly hard (c); a crimp terminal to the tube section 1,5mm and 2,5mm (d), two holes for clean cutting of metric screws M3.5 and M4 (particularly pointed out in the electrical sector) (e); side pin to create protective rings with internal diameter 4-5-6mm on wires of copper and iron particularly hard (f).
- Its particular form inclined, allows the operator to work without fatigue even in confined spaces and difficult to reach, such as: The interior of an electrical panel, engine compartment, etc.

Code	Desc.	Length
4200098511	21-185 VDE	185 mm

## Serie pinze VDE Meccanocar



- Manici in materiale plastico bicomponente (TPE).
- Finitura cromata opaca.
- Acciaio speciale al carbonio particolarmente resistente alla fatica.
- In pratica valigetta.

### Contenuto kit

CODICE	DESCR.	ARTICOLO
420 00 41181	41-18VDE	Pinza universale VDE
420 00 28161	28-16VDE	Tronchese a tagliente diagonale VDE/IEC1000V
420 00 33201	31-20VDE	Tronchese forte a tagliente diagonale VDE/IEC1000V
420 00 15201	15-20VDE	Pinza a becchi mezzitondi VDE/IEC1000V
420 00 17201	17-20VDE	Pinza a becchi mezzitondi piegati VDE/IEC1000V
420 00 78250	78-25	Pinza poligrip speedy

Code	Description
4200076261	76-261 VDE serie pinze meccanocar

## Wire strippers Automatic



- Fully automatic.
- For flexible and rigid 0.2 to 6 mm<sup>2</sup>.
- Adjusting the length of the sheath to be removed from 5 to 12mm.
- With integrated cutting blade for cables up to 2mm<sup>2</sup>

Code	Desc.	L mm	For cables mm <sup>2</sup>
4200048510	48.51	200	0,2 - 6

## Crimping pliers flap



- Burnished steel.
- PVC coated handles.
- Equipped with cutters, wire strippers and screws cut.
- Suitable for cable lugs glued.

Code	Desc.	L mm	For sect. cable mm <sup>2</sup>
3170000300	329	215	0,75-6

## Pliers for lamellar non-insulated terminals



- Original Zenit

Code	Description	Cable sec. AWG mm <sup>2</sup>	L mm
3170000305	Terminals pliers not insulated	1,5-6	215

## Automatic clamp ratchet lugs for flap



- With toggle system.
- The clamp is reopened only after the transaction.
- Handles with plastic coating.

Code	Desc.	L mm	For sect. cable mm <sup>2</sup>
3170000320	500	235	1,5-6

8

## Clamp terminals to tube



- Excellent tear resistance.
- The shape of a "V" of the stapling guarantees a perfect and compact electrical contact.

Code	Desc.	L mm	For sect. cable mm <sup>2</sup>
3170000337	795	550	10-95

## Pliers for insulated terminals



- Burnished steel.
- PVC handle.
- Equipped with cutters, wire strippers and cut screws.
- Perc lug insulated.

Code	Desc.	L mm	For sect. cable mm <sup>2</sup>
3170000280	317	215	0,75-6

## Pliers for pre-insulated terminals



- Original Zenit

Code	Description	Cable sec. AWG mm <sup>2</sup>	L mm
3170000310	Pliers for terminals insulated	1,5-6	215

## Pliers MultiCrimp



Sequenza di montaggio



- Crimping tool chrome vanadium complete carousel synthetic resin reinforced with fiberglass.
- The only professional clamp that allows the user to perform the most common crimping requirements through the quick and easy replacement of the dies.
- Intended Use: electric plant engineering, maintenance, electrician car.
- High quality crimping thanks to precision profiles and the clamping force calibrated accurately.
- Ergonomic handles covered in non-slip material.
- Fast and easy exchange of the crimping dies, without the need for additional tools. Secure fixing of the inserts in the tool parts.
- Round magazine used to keep the inserts securely and protected from dirt. With a practical belt clip for the inserts always at hand.
- Equipment: Clamp wiring with carousel inserts containing 5 parts by: lamellar uninsulated connectors from 0.5 to 6.0 mm<sup>2</sup>; insulated terminals from 0.5 to 6.0 mm<sup>2</sup>; tube pre-insulated terminals from 0.25 to 6.0 mm<sup>2</sup>; non-insulated terminals from 0.5 to 10 mm<sup>2</sup>; non-insulated butt connectors from 1.5 to 10 mm<sup>2</sup>.

Code	Desc.	Weight	Length mm
3170026250	52795	855 gr	240

## Pliers for insulated cable lugs



- Pliers with toggle system.
- The tool then opens to the merger.
- Matrix of hardened steel for heavy duty and long for car electricians, electricians...

Code	Desc.	Capacity mm <sup>2</sup>
3170000100	122	0,25-6



## Wire stripping pliers Automatic Regulation



- Caliper Automatic wire stripper synthetic resin, with special steel blades C60 containing a very high carbon content, which confers greater resistance and cutting ability.
- Ideal for stripping PVC insulated cables from 0.03 -10mm, rubber boots isolated and flat.
- Intended Use: electric plant engineering, maintenance, elettrauto, mechanical.
- Possibility to adjust the depth of cut, thanks to a wheel placed under the front of the gripper.
- Tronchese on the handle, for cutting the conductors to more copper wires and aluminum up to 10mm, and unipolar up to 6.0mm. Blades and clamping jaws in synthetic resin, both easily interchangeable.
- To ensure a long-lasting tool is recommended to oil the hinges and sliding surfaces and grease the shaft drive.

Code	Desc.	Valore di spelatura	AWG	Weight gr.	Length mm
3170026300	52845	0,03-10,0 mm <sup>2</sup>	32-7	210	200

8

## Automatic stripping pliers



- Steel body and handles made of cellulose acetate.
- With wire cutters.
- With a device for the adjustment of the stripping length.

Code	Desc.	L mm	For sect. cable mm <sup>2</sup>
3170000200	140	180	0,5-6

## Wire stripper



- Pliers small footprint.
- With adjustment of the stripping length of the cable.
- Built with cutting edge.
- Particularly appreciated by electricians, builders and elettrauto for its practicality and reliability.

Code	Desc.	Capacity mm <sup>2</sup>
3170000333	510	0-6
3170000334	510 m	Replacement spring

## Draws cables with hook blade



- Tool to remove with speed and security the outer sheath of the cable.
- For cable diameter from 8 to 28 mm.

Code	Desc.
3170025520	52652

## Pliers to tighten the terminal tube with collar isolated



- Pliers with toggle system.
- The tool then opens only when finished.
- Even series dual invitation.

Code	Desc.	For cable mm <sup>2</sup>
3170000322	502	0,5 ÷ 6

## Clamp terminals for bare and insulated tube



- For terminals tube from 0.08 to 10 mm<sup>2</sup>.
- Inlet side.
- Closing system in one operation.
- The tool then opens only to the merger.

Code	Description	Capacity mm <sup>2</sup>	Capacity AWG
3170000326	504	0.08-10	28-7
3170000327	504 m Spring parts	-	-

## Shear cutters



- For cables with aluminum conductors and copper.
- Not to be used on steel cables.
- With ratchet system to ease the strain.

Code	Desc.	For sect. cables up to	Length mm
3170000332	509	300 mm <sup>2</sup>	250

## External snap ring pliers



- Beaks rights.
- Coated handles.
- For snap rings to DIN 471 and DIN 983 to trees.
- Spring.
- Tips precise cylindrical-drained individually with high-frequency induction hardening.
- High quality steel to cromvanadium resistant to fatigue.
- For outer rings like our art. 262 00.

Code	Desc.	For rings mm	L mm
4200054030	54.03-A0	3-10	135
4200054100	54.10-A1	10-25	135
4200054190	54.19-A2	19-60	180
4200054400	54.40-A3	40-100	225
4200054850	54.85-A4	85-140	320

## External snap ring pliers



- Beaks bent at 90 °.
- Coated handles.
- For snap rings to DIN 471 and DIN 983 to trees.
- Spring.
- Tips precise cylindrical-drained individually with high-frequency induction hardening.
- High quality steel to crom-vanadium resistant to fatigue.
- For outer rings type n / s art. 262 00.

Code	Desc.	For rings mm	L mm
4200055030	55.03-A01	3-10	125
4200055100	55.10-A11	10-25	125
4200055190	55.19-A21	19-60	165
4200055400	55.40-A31	40-100	210

## Ring pliers interior



- Beaks rights.
- Coated handles.
- For snap rings to DIN 472 and DIN 984 for drilling.
- Tips precise cylindrical-drained individually with high-frequency induction hardening.
- High quality steel to crom-vanadium resistant to fatigue.
- For inner ring type our art. 263 00.

Code	Desc.	For rings mm	L mm
4200056080	56.08-J0	8-13	140
4200056120	56.12-J1	12-25	140
4200056190	56.19-J2	19-60	180
4200056400	56.40-J3	40-100	225
4200056850	56.85-J4	85-140	315

## Ring pliers internal beaks at 90°

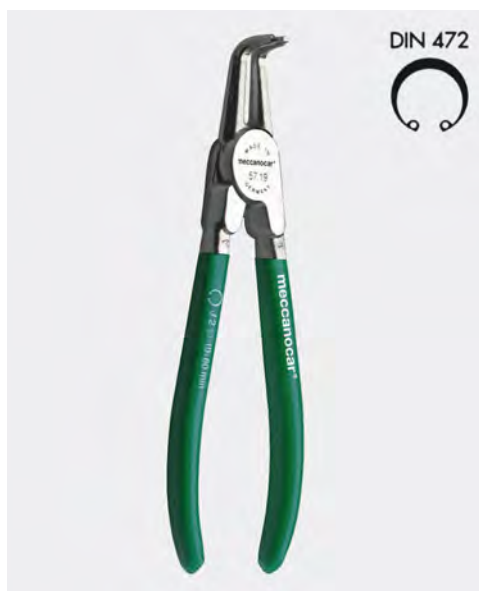

- Beaks bent at 90 °.
- Coated handles.
- For snap rings to DIN 471 and DIN 984 for drilling.
- Tips precise cylindrical-drained individually with high-frequency induction hardening steel to high quality chrom-vanadium resistant to fatigue.
- For inner ring type our art. 263 00.

Code	Desc.	For rings mm	L mm
4200057080	57.08-J01	8-13	125
4200057120	57.12-J11	12-25	125
4200057190	57.19-J21	19-60	165
4200057400	57.40-J31	40-100	210
4200057850	57.85-J41	85-140	295

## Pliers for external circlips

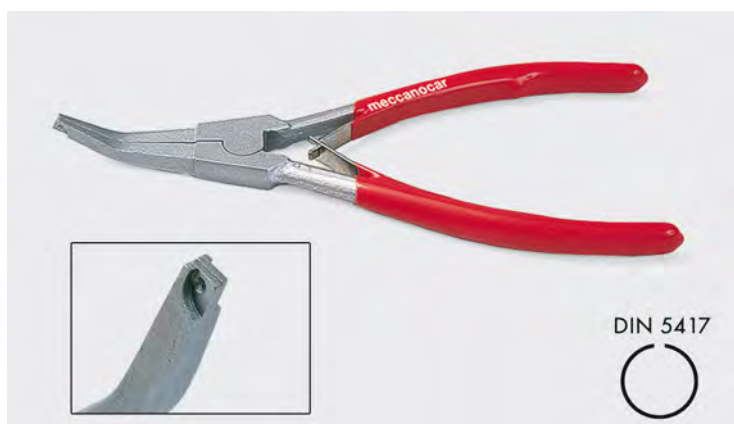

- Pliers with bent tips at 30° with housings which ensure a secure grip on external circlips.
- It allows you to safely perform repairs on transmissions - CV joints - engines and transmissions.
- Spring clamp equipped with beaks folded and provided with special shaping which ensure a secure grip.
- For all workshops, car electricians and

Code	Desc.
4770001730	173

### Grip self locking pliers



- Concave jaws.
- Adjustable.
- Jaws made of chrome-vanadium.

Code	Desc.	L mm
4430015090	247-180	180
4430015100	247-250	250

### Grip self-locking pliers with cutting edge



- Concave jaws.
- With side cutter.
- Adjustable.
- Jaws made of chrome-vanadium.

Code	Desc.	L mm
4430049270	910-100	100
4430049275	910-125	125
4430049280	910-175	175
4430049285	910-250	250

8

### Grip self locking pliers



- Straight jaws.
- Adjustable.
- Jaws made of chrome-vanadium.

Code	Desc.	L mm
4430049160	897-175	175
4430049162	897-250	250

### Grip self locking pliers



- Pointy beaks.
- Adjustable.
- Beaks made of chrome-vanadium.
- Suitable for grip in places difficult to access.

Code	Desc.	L mm
4430049170	898-100	100
4430049172	898-150	150
4430049174	898-225	



## Grip self locking pliers



- A jaw wider.
- Adjustable.
- Beaks made of chrome-vanadium.
- Beaks shaped for secure grip on any form.

Code	Desc.	L mm
4430049190	900-300	250

## Grip self locking pliers with specially shaped beaks



- Specially shaped beaks.
- Specifications for hexagonal heads.
- Jaws made of chrome-vanadium.

Code	Desc.	For hexagonal heads
4430049555	947-180	7 A 14

## Grip self locking pliers



- Wide jaws for the passage of the welder.
- Adjustable.
- Jaws made of chrome-vanadium.
- For grip and a secure hold on corners and needles "U".

Code	Desc.	L mm
4430015200	248-260	225

## Grip self locking pliers



- Jaws bent fork.
- Adjustable.
- Jaws made of chrome-vanadium.
- For the welding of pipes.

Code	Desc.	L mm
4430015300	249-280	275

### Grip self locking pliers



- Jaws to "C".
- Adjustable.
- Jaws made of chrome-vanadium.
- For locking profiles and angular.

Code	Desc.	L mm	A x B mm
4430015400	250-280	280	75x95

### Grip self locking pliers

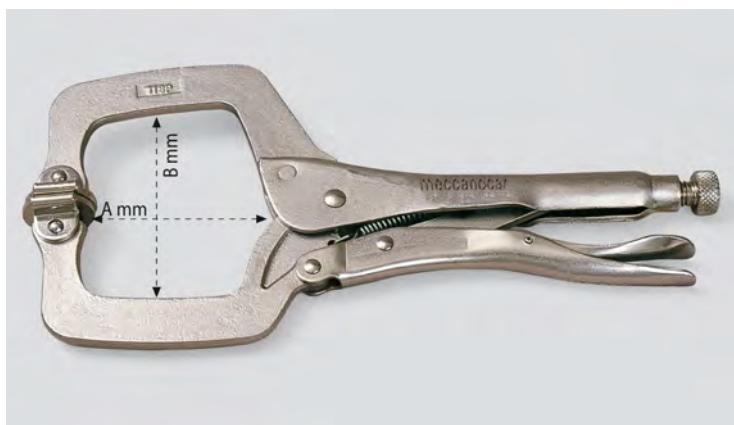

- Jaws "C" - with steerable feet adjustable.
- Jaws made of chrome-vanadium.
- For locking profiles and angular.

Code	Desc.	L mm	A x B mm
4430049200	901-150	150	32x55
4430049202	901-275	275	70x90
4430049204	901-455	455	240x105

### Grip self locking pliers



- A long jaws for car bodies.
- Adjustable.
- Jaws made of chrome-vanadium.
- For blockages in depth.

Code	Desc.	L mm	A x B mm
4430015600	252-455	455	240x105
4430015610	252-605	605	400x110

### Grip self locking pliers



- Flat jaws to scoop.
- Adjustable.
- Jaws made of chrome-vanadium.
- For clamping of floors.

Code	Desc.	L mm
4430015500	251-250	200

## Self adjusting grip pliers



- Self-locking pliers with concave jaws.
- It is used by mechanics, body shop, car repair, plumbing, carpenters and blacksmiths.
- It can be used to block moving parts, nuts, bolts, hydraulic hoses and any other application can.
- Thanks to the cutting edge can also be used as cutters for electric cables or steel cables.
- It has an innovative system of self-regulation to two opposing springs that allows the jaws to adjust automatically to the thickness of the material simply closing it.
- It does not require any adjustment for any thickness to block.
- It is able to pass from the locking of a sheet to a piece of large dimensions without any adjustment.
- It is used without the adjusting screw typical of the grippers blockers, even with one hand.
- Thanks to an internal screw is adjusted only once the clamping pressure, and this will be applied to all sizes blocked
- Jaws made of chrome molybdenum guarantees a long life and rust prevention.

Code	Desc.	Length mm	Jaw opening mm
4430015110	247AR-150	150	0 - 32
4430015120	247AR-250	250	0 - 47

## Pincer grip chain



- For blockages particularly difficult.
- Adjustable.
- Strong chain which guarantees the grip even on materials of different nature.

Code	Desc.	L mm	Lunghezza catena mm
4430049220	903	225	455

## Automatic Robo-Grip pliers



- Self-adjusting pliers.
- The jaws (curves) fit to the workpiece with speed and precision.
- Spring opening for use with a single hand.
- Ergonomic handle with PVC coating.
- For all professional applications.

Code	Desc.	Capacity opening Max mm
4430049575	949-230	40



## Protection jaws



- Guards jaws allow a grip without damage on all painted or delicate materials.

Code	Desc.
4430049585	950-230

## Pliers poligrip hinged closed



- Hinge 7 adjustment positions.
- PVC insulated handles.
- Jaws and hinge high strength thanks to a special remediation induction.
- Stop finger.
- Chrome steel-vanadium.
- Resistant to fatigue.

Code	Desc.	L mm	Opening mm
4200077240	77-24	240	10-36
4200077300	77-30	300	10-48

8

## Pliers POLIGRIP speedy



- Hinge 10 adjustment positions.
- Automatic system for gripping the part.
- PVC insulated handles.
- Jaws and hinge high strength thanks to a special remediation induction.
- Stop finger.
- Chrome-vanadium steel hardness 52-56 HRC.
- Resistant to fatigue.

Code	Desc.	L mm	Opening mm
4200078250	78.25	250	6-38
4200078330	78.33	330	6-48

## Pipe wrenches Swedish type



- Beaks bent at 90°.
- Serrated jaws with induction hardening additional.
- Tempera integral.
- Adjusting nut with a stop.
- Finish: stove enamelled for long life.
- Crom-vanadium steel resistant to fatigue.

Code	Desc.	L mm	For pipes up to mm
4200098110	98-11-1"	325	50
4200098120	98-12-1"-1/2	415	60
4200098130	98-13-2"	540	80
4200098140	98-14-3"	685	105

## Pipe wrenches Swedish type



- Beaks bent at 45 °.
- Serrated jaws with induction hardening additional.
- Tempera integral.
- Adjusting nut with a stop.
- Finish: stove enamelled for long life.
- Crom-vanadium steel resistant to fatigue.

Code	Desc.	L mm	For pipes up to mm
4200098220	98.22-1"	335	45
4200098230	98.23-1-1/2"	430	55
4200098240	98.24-2"	555	70

## Pipe wrenches model Stillson

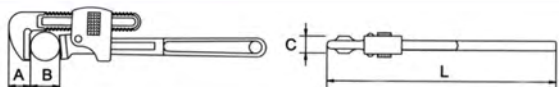

- Pipe wrenches Stillson model.
- Body and steel clamp. Adjusting the bite screw.
- Device double spring in the tool body for the immediate locking of the pipe and a rapid recovery of the maneuver.
- Sector of use: heating and plumbing, body.
- Suitable for pipes of small and medium size.

Code	Desc.	L mm	A mm	B mm	C mm	Weight Kg.
4430055105	1131	250	23	1"	15,6	0,65
4430055110	1132	350	28	1 1/2"	20,6	1,15

## American model pipe wrenches

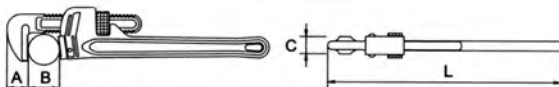

- American model pipe wrenches.
- Body and steel clamp. Adjusting the bite screw.
- Sector of use: heating and plumbing, body.
- Suitable for pipes of small and medium size.

Code	Desc.	L mm	A mm	B mm	C mm	Weight Kg.
4430055115	1133	203	15	1"	13,8	0,42
4430055120	1134	254	20	1 1/2"	17,0	0,83



## Aluminum pipe wrench American model

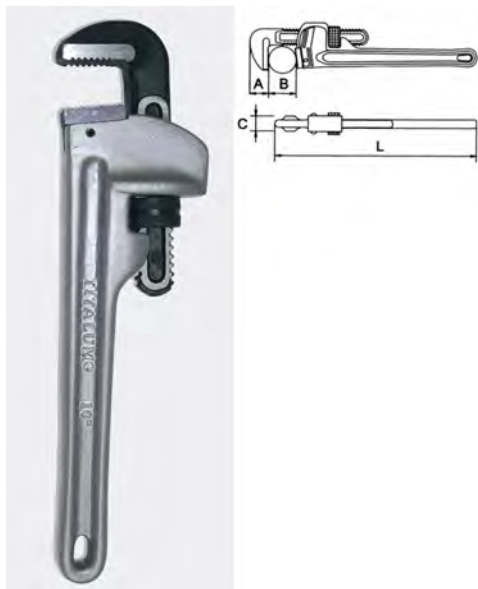

- American model pipe wrenches.
- Body and aluminum clamp. Adjusting the bite screw.
- Lightweight and robust is ideal to carry toughest jobs, such as tightening of large pipes.
- Sector of use: heating and plumbing, body.
- Suitable for pipes of medium and large size.

Code	Desc.	L mm	A mm	B	C mm	Weight Kg.
4430055125	1135	250	20	1 1/2"	17	0,5
4430055130	1136	300	23	2"	19,6	0,78
4430055135	1137	350	25	2"	22,8	0,95
4430055140	1138	450	28	2 1/2"	26	1,64
4430055145	1139	600	33	3"	28,8	2,57
4430055150	1140	900	43	5"	32,6	4,96

## Pipe wrenches automatic Meccanocar



- Pipe wrench special steel with automatic jaw.
- The special steel allows the user to enjoy all the necessary force on the tube / nut without affecting the strength of the tool.
- **Use sectors:** plumbers, installers, repairers and earthmoving
- **Advantages:** automatic spring mechanism that allows the jaw to quickly adapt to various pipe diameters.
- Effect ratchet for tightening and resume the socket without removing the key from the tube.
- you can use the tool with one hand, thanks to the ergonomic handle.
- High adhesion on the tube thanks to the specially designed teeth.
- Sturdy and durable, insulated unscrew and screw pipes blocked by rust.



Code	Desc.	For pipe diam. inch	Serraggio massimo dado	Length cm	Weight Kg.
4430054270	1112	1/2-2"	17-50 mm	33	1,65

## Chain pipe wrenches



- It allows you to tighten or remove both ways without removing the tool.
- Great for removing filters.

Code	Desc.	For pipe diam. inch	L mm
4430040200	447	4"	340

## Tongs



- Cutting front.
- Cutters additional induction hardening.
- For soft wire and hard.
- Sharp Hardness: 58-61 HRC.
- Ideal to tie, twist and cut wire ligature.

Code	Desc.	L mm
4200093220	93-22	220
4200093250	93-25	250
4200093280	93.28	280

## Plate shears type American



- For through cuts.

Code	Desc.	L mm
4430022710	300-280	280

## Plate shears, right cut



Code	Desc.	L mm
4430022810	301-280	280

**Plate shears, cut left**

Code	Desc.	L mm
4430022910	302-280	280

**Nibbler for sheet metal with shearer**

- Keyless entry.
- Insulated handles.
- Cuts round and rectangular unhindered chip.
- Cutting capacity: sheet steel mm1,2; plastic and other materials mm<sup>2</sup>.

Code	Description
4430039400	437
4430039410	438 SPARE BLADE

8

**Plate shears, double lever straight cut**

- Keyless entry.
- Handles P.V.C.

Code	Desc.	L mm
4430049250	906-250	250

**Plate shears, double lever right cut**

- Keyless entry.
- Handles P.V.C.

Code	Desc.	L mm
4430049255	907-250	250

## Shears for sheet metal cutting double lever left



- Keyless entry.
- Handles P.V.C.

Code	Desc.	L mm
4430049260	908-250	250

## Tin snips double lever for cutting right and left for processing medium-heavy



- Shears Double lever in chrome molybdenum steel with non-slip handles.
- Automatic opening and locking lever.
- Intended Use: plumbing, carpentry, locksmiths, car body shops, machine shops in general.
- Suitable for cutting sheet metal up to 1,8 mm and stainless steel foils up to 1.2 mm.
- Serrated blade that gives a bite on the plate.
- Double lever system that significantly decreases the force to be applied by the operator.
- Ergonomic handle that helps the operator to give the greater pressure during cutting and then to speed up their work.

Code	Desc.	Cutting direction	Taglio max lamiera mm	Taglio max lamiera inox A2 mm	Length total mm	L. Blade mm	Weight Kg.
4430055450	1245	Right R	1,8	1,2	260	33	0,52
4430055455	1250	Left L	1,8	1,2	260	33	0,52

## Cesoia per taglio guarnizioni



- Utensile indispensabile per un taglio netto e preciso.
- Utilizzato per il taglio anche a 45° delle guarnizioni degli infissi.
- La particolare conformazione del supporto di taglio rendono l'utensile pratico e maneggevole.
- La lama di ricambio, e' intercambiabile anche sulle cesoie di altre marche presenti in commercio.
- Il supporto a 45° puo' essere sostituito e come la lama e' intercambiabile.

Code	Description
4430050040	948-CESOIA X TAGLIO GUARNIZIONI A 45°
4430050045	984/L LAMA DI RICAMBIO X CESOIA
4430050050	984/W SUPPORTO X TAGLIO A 45°

## Bolt cutters in sharp central



- Cutting edge patented partially serrated profile for holding the round during the cutting.
- Adjustable stop device for the correct alignment of the blades.
- Blades made of chrome-vanadium.
- Handles made of tubular steel.
- Handle P.V.C.
- Painted version and phosphate.

Code	Description	L mm	Ø max mm
4430049140	896-450	450	7
4430049144	896-750	750	13
4430049150	896R-450 SPARE PARTS	-	-
4430049154	896R-750 SPARE PARTS	-	-

## Curve pipe clamp in copper



- Hand tool for the curvature of the tubes in COPPER
- The special throat prevents the crushing of the tube
- Ideal for motorcycle repair shops, auto, industrial and hydraulic vehicles.
- Use the tool to the right of the tube diameter

Code	Description	Ø est. tubo
4430057700	1775-6 benders mm 6	6
4430057710	1775-8 benders mm 8	8
4430057720	1775-10 benders mm 10	10
4430057730	1775-12 benders mm 12	12
4430057740	1775-14 benders mm 14	14
4430057750	1775-15 benders mm 15	15
4430057760	1775-16 benders mm 16	16



## Pipe cutter



- For steel pipes; copper; brass.
- With a wheel and two guide rollers.

Code	Desc.	Capacity tubes " / mm	Weight gr.
4430015800	254-370	1/8÷2 3÷50	3000

## Pipe cutter standard



- Usable on copper tubes and light alloys, including aluminum, brass, stainless thin, rigid PVC.
- With countersink.

Code	Description	For pipes Ø mm	For pipes Ø "	Length mm	Weight gr.
4430054060	1092	3-30	1/8"-1.1/8"	145	290
4430054065	1092/R lama ricambio	3-30	1/8"-1.1/8"	-	-

## Spare wheel



- For pipe cutter our art. cod. 443 00 15800 - 254-370.

Code	Desc.	For pipes Ø "
4430015900	255	1/8-2

## Pipe cutter



- For copper and aluminum alloy.
- Model with telescopic advance and constant clutter.
- Supplied with a spare wheel in serita in pommel.
- With deburring.

Code	Desc.	Capacity tubes " / mm	Weight gr.
4430016110	257-6-35	1/4÷1-3/8 6-35	290

## Spare wheel



- For pipe cutter our art. cod. 443 00 16110-257 -6 - 35.

Code	Desc.
4430016120	257/1

## Pipe cutter



- For copper and aluminum alloy.
- Model of restricted radius of rotation to operate in confined spaces.
- Light alloy body.

Code	Description	For pipes Ø mm	For pipes Ø "	Length mm	Weight gr.
4430054560	1118	3-16	1/8"-5/8"	45	90
4430054565	1118 / R Spare wheel	3-16	1/8"-5/8"	-	-

## Pipe cutter



- Pipe exhaust.
- Essential in catalytic converters having the thickness of the tubes very high.
- With roller chain in American steel.
- Maximum diameter: 70mm.

Code	Desc.
4430040100	446

8

## Cutting pliers



- Clamp with hardened steel blade high strength.
- Cut perfectly without crushing pipes Rilsan; nylon; plastic and rubber.

Code	Description	For pipes max mm
3760000100	20485	28
3760000200	20486 REPLACEMENT BLADE	-

## Scissors for pipes



- Shear with ratchet operation.
- The ratchet mechanism allows to carry out cuts with one hand.
- The special blade allows you to cut pipes in: PE, PP, PB, VPE, PVDF, HTA (CPVC) and Kevlar.
- Excellent cut flawless. With non-slip rubber on the handle. Replacement blade available cod.443 00 54575.

Code	Description	For pipes Ø mm	Length mm	Weight gr.	Tubo
4430054570	1119	0-42	225	550	KEVLAR, PVC, PE, PP, PB, VPE, PVDF, MLP, HTA.
4430054575	1119 / R replacement blade	0-42	-	-	KEVLAR, PVC, PE, PP, PB, VPE, PVDF, MLP, HTA.

## Hammer German type



- With blocking system of the handle.
- DIN 1041.
- High tensile steel.
- Painted head shaped handle.

Code	Desc.	Weight gr.
4430013300	229-300	300
4430013310	229-400	400
4430013320	229-500	500
4430013330	229-600	600
4430013340	229-1000	1000
4430013350	229-1500	1500
4430013360	229-2000	2000

## Handles for hammers



- Shaped wood.

Code	Desc.	For hammer gr.	Length mm
4430014100	237-300	300	300
4430014110	237-400	400	310
4430014120	237-500	500	320
4430014130	237-600	600	350
4430014140	237-800	800	360
4430014150	237-1000	1000	360
4430014160	237-1500	1500	380
4430014170	237-2000	2000	400

## Hammer mechanics



- Steel swing with gouache differentiated.
- Anatomic handle security.
- Balancing constant.
- Maximum guarantee of safety against accidents.
- Synthetic handle with blocking system.

Code	Desc.	Weight gr.
4430045635	601-300	300
4430045640	601-500	500

## Hammer for welders



- Hammer two-headed welder.
- For removing welding slag.
- Iron grip.

Code	Desc.
4430045642	602

## Hammer for masons and mechanics



- According to DIN 6475.
- Shaped wooden handle.

Code	Desc.	Weight gr.
4430013900	235-800	800
4430013910	235-1000	1000
4430013920	235-1500	1500

## Handle for power hammer



- Shaped wood.

Code	Desc.	For small mallet gr.	Length mm
4430014000	236-800	800	260
4430014010	236-1000	1000	260
4430014020	236-1500	1500	280

## Power hammer safety



- Power hammer made of hardened steel.
- Balancing constant.
- Maximum guarantee of safety against accidents.
- Resin handle with sitema fraying.

Code	Desc.	Weight gr.
4430045740	609-800	800
4430045742	609-1000	1000

## Mallet monolithic copper



- Strong beat.
- It does not damage the pieces.
- Safety plug for retaining the head.

Code	Desc.	Weight gr.
4430045660	604-500	500
4430045661	604-800	800
4430045662	604-1000	1000
4430045664	604-1500	1500



## Plastic mallet



- Unbreakable plastic heads interchangeable.
- Wooden handle.

Code	Desc.	Ø testa mm	Weight gr.
4430013400	230-35	35	420
4430013410	230-45	45	770
4430013420	230-60	60	1440

## Spare heads for art. 443-230 (per couple)



- Heads unbreakable plastic.

Code	Desc.	Ø testa mm
4430013500	231-35	35
4430013510	231-45	45
4430013520	231-60	60

## Mallet debounced



- Do not recoil.
- Optimal precision in the rebate.
- Interchangeable heads resin.

Code	Desc.	Ø testa mm	Weight gr.
4430045615	600-35	35	530
4430045617	600-45	45	790
4430045619	600-60	60	1350

## Spare heads for art. 443-600 (per couple)



- Heads in synthetic resin.

Code	Desc.	Ø testa mm
4430045625	600R-35	35
4430045627	600R-45	45
4430045629	600R-60	60

## Monolithic black rubber mallet



- Tubular handle security.
- Oil-resistant rubber.

Code	Desc.	Weight gr.
4430045680	606	500
4430045680	606	500

## Monolithic black rubber mallet



- Shaped wooden handle.
- 75 to 80 shore hardness.

Code	Desc.	Weight gr.
4430013810	234-50	300
4430013820	234-60	500
4430013830	234-70	600
4430013840	234-75	700

## Series punches in numbers



- Nr. 9 numbers.

Code	Desc.	Height Sym. mm
4430045180	548-3	3
4430045185	548-8	8

## Series punches in letters



- Nr. 27 letters.

Code	Desc.	Height Sym. mm
4430045388	578-8	8

## Pointed chisel flat



PER IDRAULICI,  
SERRAMENTISTI, FABBRI,  
CARPENTIERI, MURATORI

- Made of chrome-vanadium hardened.
- High resistance. Marking quality 'GS'.
- The head of the chisel does not leave splinters during processing.
- Article 443 00 51690 to the norm DIN 7254B.
- Reversible blade tip.
- To use always with safety glasses, work gloves and Meccanocar with hand guard for chisels cod. 4430051750.

Code	Desc.	Length mm	Diameters	Weight gr.	L. Blade mm
4430051690	1055/250	250	16	380	23
4430051700	1055/300	300	16	420	26
4430051710	1055/400	400	18	900	28



## Pointed chisel



PER IDRAULICI,  
SERRAMENTISTI, FABBRI,  
CARPENTIERI, MURATORI

- Made of chrome-vanadium hardened.
- High resistance. Quality marking GS.
- The head of the chisel does not leave splinters during processing.
- Article 443 00 51720 to the norm DIN 7256.
- Reversible blade tip.
- To use always with safety glasses, work gloves and Meccanocar with hand guard for chisels cod. 4430051750.

Code	Desc.	Length mm	Diameters	Weight gr.
4430051720	1056/250	250	16	365
4430051730	1056/300	300	16	445
4430051740	1056/400	400	18	750

## Chisels for electricians



DA UTILIZZARE SEMPRE CON  
OCCHIALI E GUANTI PER  
PROTEZIONE MECCANOCAR

- Chisels for electricians.
- Made of chrome-vanadium hardened.
- High resistance.
- The head of the chisel does not leave splinters during processing.
- GS marked tool.
- Reversible blade tip.

Code	Desc.	Leng. mm	Ø	Weight gr.	Width mm
4430051760	1058/250	250	8	120	10
4430051770	1058/300	300	10	230	12

## Hand guard for chisels



PIU' SICUREZZA  
NEL LAVORO

- Rubber hand guard.
- GS marked.
- It fits on all chisels with octagonal diameter from 16 up to 20.
- High strength and practical non-slip grip.

Code	Desc.	Length mm	For chisels	Weight gr.
4430051750	1057	110	16 -18 - 20	105

## Flat chisel for mechanics



- Chisel flat oval.
- Chrome steel-vanadium.
- A DIN 6453 standards.
- Finish: gold lacquer, polished tip.
- Suitable for cutting sheet metal.

Code	Desc.	Fig.	Ø Gambo / mm	Lunghezza gambo mm
4430056320	1752-240	1	26x7	240
4430056322	1752P-240	2	26x7	240

## Flat chisel bent for mechanics

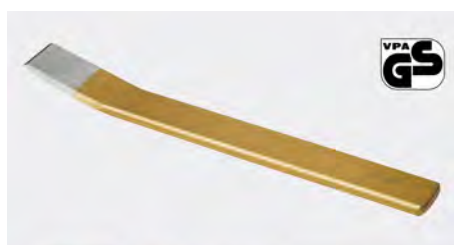

- Chisel flat oval.
- Chrome steel-vanadium.
- Finish: gold lacquer, polished tip.
- Suitable for cutting sheet
- The special folding favors its use in cutting step of projecting parts code.

Code	Desc.	Stem measure mm	Lunghezza gambo mm
4430056325	1753-240	26x7	240



LA PARTICOLARE PIEGATURA NE FAVORISCE L'UTILIZZO IN FASE DI TAGLIO SU PARTI SPORGENTI

## Hand guard for chisels



- Rubber hand guard.
- Suitable for all the chisels 26x7mm oval shank. head 85mm.
- Scalpel type the our art 1752-1752p-1753.

Code	Desc.	Misura head mm
4430056330	1754	85

## Chisels for mechanics



- Chisel octagonal handle.
- Chrome steel-vanadium.
- A DIN 6453 standards.
- Finish: gold lacquer, polished tip.
- Suitable for cutting metal and sheet

Code	Desc.	Measure stem x Length mm	Width cut mm
4430056300	1750-10x125	10x125	12
4430056305	1750-10x150	10x150	12

## Pointed chisel for mechanics



- Chisel octagonal handle.
- Chrome steel-vanadium.
- According to DIN 6451.
- Finish: gold lacquer, polished tip.
- Suitable for cutting metal sheet and finishes in confined spaces.

Code	Desc.	Measure <i>stem x Length mm</i>	Width <i>cut mm</i>
4430056310	1751-10x125	10x125	4

## Awls



- Awl octagonal handle.
- Made of chrome-vanadium.
- A DIN 7250 standards.
- Finish: gold lacquer, polished tip.
- Suitable for marking metal and sheet

Code	Desc.	Measure <i>stem x Length mm</i>	Width <i>cut mm</i>
4430056335	1755-120x4	4x120	10
4430056340	1755-120x5	5x120	10

8

## Punch octagonal handle



- Chrome-vanadium steel.
- F standards din 6458.
- Finish: gold lacquer, polished tip.
- Suitable for riveting metals and alloys

Code	Desc.	Measure <i>stem x Length mm</i>	Stem <i>octagonal</i>
4430056343	1756-120x1	1x120	10
4430056344	1756-120x2	2x120	10
4430056345	1756-120x3	3x120	10
4430056346	1756-120x4	4x120	10
4430056347	1756-120x5	5x120	10
4430056348	1756-120x6	6x120	10



## Hunting pins



- Hunting plugs octagonal handle.
- Made of chrome-vanadium.
- A DIN 6450 standards.
- Finish: gold lacquer, polished tip.
- Suitable for extraction pins, screws etc.

Code	Desc.	Measure <i>length x Ø tip mm</i>	Stem <i>octagonal</i>
4430056350	1757-150x2	150x2	10
4430056355	1757-150x2,5	150x2,5	10
4430056360	1757-150x3	150x3	10
4430056365	1757-150x4	150x4	10
4430056370	1757-150x5	150x5	10
4430056375	1757-150x6	150x6	10
4430056380	1757-150x8	150x8	12
4430056385	1757-150x10	150x10	14

## Handguard tool shank 10mm



- Handguard rubber-component.
- Suitable for all tools with shank 10mm.
- It gives the operator an adequate hand protection.
- For chisels, punches, punches.
- Head 30mm.

Code	Desc.	Misura head mm
4430056390	1758	85

## Mixed series



- Mixed batch of chisels, punches and punch.
- Series of 6 pieces.
- On plastic support.

Code	Desc.
4430056395	1759

CONTENUTO			
	CODICE	DESCRIZIONE	Misura
1	443 00 56300	1750	10x125
1	443 00 56305	1750	10x150
1	443 00 56310	1751	10x125
1	443 00 56395	1755	120x4
1	443 00 56345	1756	120x3
1	443 00 56346	1756	120x4
1	supporto in plastica		

## Mixed batch punches and punch



- Mixed batch of 6 pieces of punches and punch.
- On plastic support.

Code	Desc.
4430056400	1760

CONTENUTO			
	CODICE	DESCRIZIONE	Misura
1 punzone	443 00 56343	1756	120x1
1 punzone	443 00 56344	1756	120x2
1 punzone	443 00 56345	1756	120x3
1 punzone	443 00 56346	1756	120x4
1 punzone	443 00 56347	1756	120x5
1 punteruolo	443 00 56355	1755	120x4
1 supporto in plastica			

## Pin punches Series



- Set of 6 pin punches.
- Plastic support.

Code	Desc.
4430056405	1761

CONTENUTO			
	CODICE	DESCRIZIONE	Misura
1 cacciaspine	443 00 56360	1757	150x3
1 cacciaspine	443 00 56365	1757	150x4
1 cacciaspine	443 00 56370	1757	150x5
1 cacciaspine	443 00 56375	1757	150x6
1 cacciaspine	443 00 56380	1757	150x8
1 cacciaspine	443 00 56385	1757	150x10
1 supporto in plastica			

8

## Series punch with hand guard



- 5 Series punch with hand guard.
- In plastic box.
- The hand guard makes using tools degle safer.

Code	Desc.
4430056410	1762

CONTENUTO						
	CODICE	DESCR.	Misura		CODICE	DESCR.
1 cacciaspine	443 00 56350	1757	150x2	paramano	443 00 56390	1758
1 cacciaspine	443 00 56360	1757	150x3	paramano	443 00 56390	1758
1 cacciaspine	443 00 56365	1757	150x4	paramano	443 00 56390	1758
1 cacciaspine	443 00 56370	1757	150x5	paramano	443 00 56390	1758
1 cacciaspine	443 00 56375	1757	150x6	paramano	443 00 56390	1758
1 cassetta in materiale plastico						

## Lever type disarmament French



- Lever disarmament (crowbar) forged steel with nail heads to open and chisel. Total length 600 mm.

Code	Desc.	Measure cm	Diam. mm
4430053950	1085/60	60	16

## Set of four forged steel levers and tempered



- Complete set of four forged steel levers and tempered surface finish with burnished tip bent chisel and plastic handle.
- Useful in many situations and in every work, their strength allows it to be used as disarmament levers for opening boxes, such positioning levers, such as chisels and extractors and much more.
- The tip bent at 30 ° allows easy and convenient use, the extremely durable steel blade guarantees a long life and prevents any kind of accident during use.
- The complete set consists of the measures: 11 X 200 mm, 15 x 300 mm, 19 mm X 460, 19 X 600mm.

Code	Desc.
4770006770	747

## Thermo keys t articulated 6-19



- In low density polyethylene foam.
- Format 415x576mm 3/3 drawer

Code	Desc.
4200004030	4030

CONTENUTO	
<b>398 00 04030</b>	<b>termoformato vuoto 415x576</b>
420 00 27106	6
420 00 27107	7
420 00 27108	8
420 00 27110	10
420 00 27111	11
420 00 27113	13
420 00 27117	17
420 00 27119	19

## Thermo pipe wrenches hexagonal / Polygonal 6 to 22



- In low density polyethylene foam.
- Format 415x376mm 2/3 of the tray.

Code	Desc.
4200004031	4031

CONTENUTO	
<b>398 00 04031</b>	<b>termoformato vuoto 415x376</b>
420 00 27206	6
420 00 27207	7
420 00 27208	8
420 00 27209	9
420 00 27210	10
420 00 27211	11
420 00 27212	12
420 00 27213	13
420 00 27214	14
420 00 27215	15
420 00 27216	16
420 00 27217	17
420 00 27218	18
420 00 27219	19
420 00 27220	20
420 00 27221	21
420 00 27222	22

## Thermoformed keys 3 heads hexagonal Meccanocar



Code	Description	Content/size
4200058900	589 - THERMOFORMED wrench 2-10	Mis. 2-2,5-3-4-5-6-8-10
3980003130	313 - EMPTY THERMOFORMED	-

- In ABS.
- Specifico per carrelli Meccanocar.
- Formato 2/3 del cassetto:415x376 mm.



## Thermo keys T Allen sets 2-10

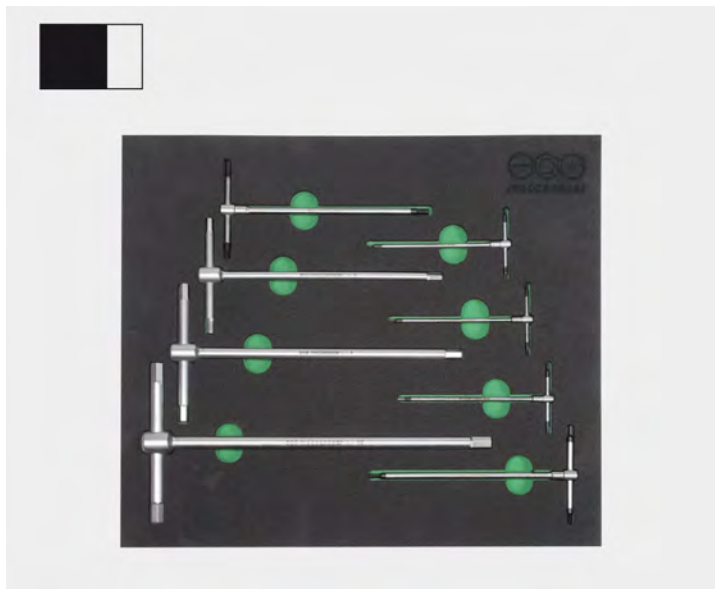

- In low density polyethylene foam.
- Format 415x376mm 2/3 of the tray.

Code	Desc.
4200004029	4029

CONTENUTO	
398 00 04029	termoformato vuoto 415x376
420 00 58902	2
420 00 58925	2,5
420 00 58903	3
420 00 58904	4
420 00 58905	5
420 00 58906	6
420 00 58908	8
420 00 58910	10

## Thermo keys T fixed long type 6 to 19

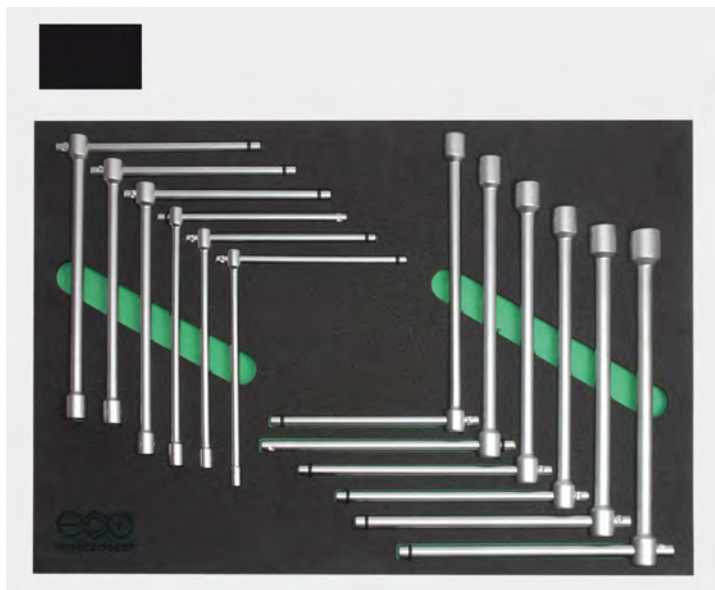

- In low density polyethylene foam.
- Format 415x576mm 3/3 drawer.

Code	Desc.
4200004046	4046

CONTENUTO	
398 00 04046	termoformato vuoto 415x576mm
420 00 27006	6
420 00 27007	7
420 00 27008	8
420 00 27010	10
420 00 27011	11
420 00 27012	12
420 00 27013	13
420 00 27014	14
420 00 27015	15
420 00 27016	16
420 00 27017	17
420 00 27019	19



## Socket wrenches

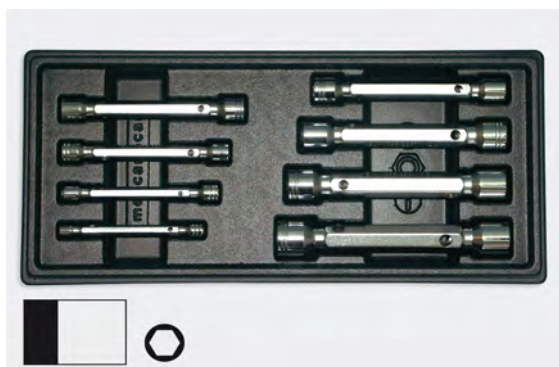

- Format 188x415 1/3 drawer.

Code	Description/composition
4200003140	314 thermo full
3980003140	314 - thermoformed vacuum socket wrench 6x7 - 20x22
4200098700	6x7 socket wrench double
4200098710	8x9 socket wrench double
4200098715	10x11 socket wrench double
4200098720	12x13 socket wrench double
4200098725	14x15 socket wrench double
4200098730	16x17 socket wrench double
4200098735	18x19 socket wrench double
4200098740	20x22 socket wrench double



## Thermo wrench heavy 6x7 to 20x22



- In low density polyethylene foam.
- Format 415x188mm 1/3 drawer

Code	Desc.
4200004032	4032

CONTENUTO	
<b>398 00 04032</b>	<b>termoformato vuoto 415x188</b>
<b>420 00 98700</b>	<b>6x7</b>
<b>420 00 98710</b>	<b>8x9</b>
<b>420 00 98715</b>	<b>10x11</b>
<b>420 00 98720</b>	<b>12x13</b>
<b>420 00 98725</b>	<b>14x15</b>
<b>420 00 98730</b>	<b>16x17</b>
<b>420 00 98735</b>	<b>18x19</b>
<b>420 00 98740</b>	<b>20x22</b>
<b>420 00 98770</b>	<b>10x22 asta di manovra</b>

## combination wrenches

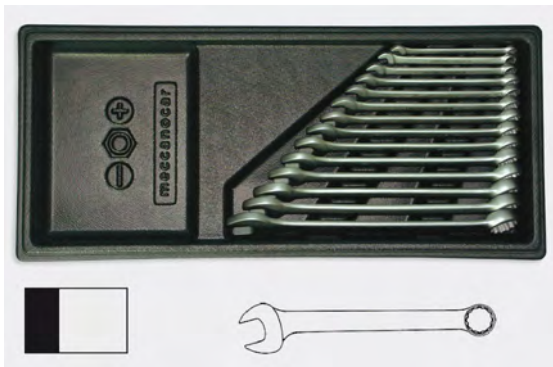

- Formato 415x188-1/3 cassetto.

Code	Description/composition
4200003070	307 thermo full
4200011006	11-6 combination wrench
4200011007	11-7 combination wrench
4200011008	11-8 combination wrench
4200011009	11-9 combination wrench
4200011010	11-10 combination wrench
4200011011	11-11 combination wrench
4200011012	11-12 combination wrench
4200011013	11-13 combination wrench
4200011014	11-14 combination wrench
4200011015	11-15 combination wrench
4200011016	11-16 combination wrench
4200011017	11-17 combination wrench
4200011018	11-18 combination wrench
4200011019	11-19 combination wrench

## combination wrenches

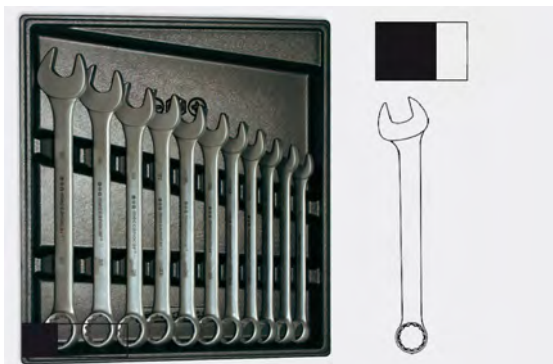

- Formato 415x376-2/3 cassetto.

Code	Description/composition
4200003080	308 thermo full
3980003080	308 - thermoformed empty combination wrench 20-32
4200011020	11-20 combination wrench
4200011021	11-21 combination wrench
4200011022	11-22 combination wrench
4200011023	11-23 combination wrench
4200011024	11-24 combination wrench
4200011025	11-25 combination wrench
4200011026	11-26 combination wrench
4200011027	11-27 combination wrench
4200011028	11-28 combination wrench
4200011030	11-30 combination wrench
4200011032	11-32 combination wrench

## Thermo combination wrenches 6 to 22



- In low density polyethylene foam.
- Format 415x376mm 2/3 of the tray.

Code	Desc.
4200004026	4026

CONTENUTO	
398 00 04026	termoformato vuoto 415x376
420 00 11006	6
420 00 11007	7
420 00 11008	8
420 00 11009	9
420 00 11010	10
420 00 11011	11
420 00 11012	12
420 00 11013	13
420 00 11014	14
420 00 11015	15
420 00 11016	16
420 00 11017	17
420 00 11018	18
420 00 11019	19
420 00 11020	20
420 00 11021	21
420 00 11022	22

## Thermo combination wrenches 23 to 36

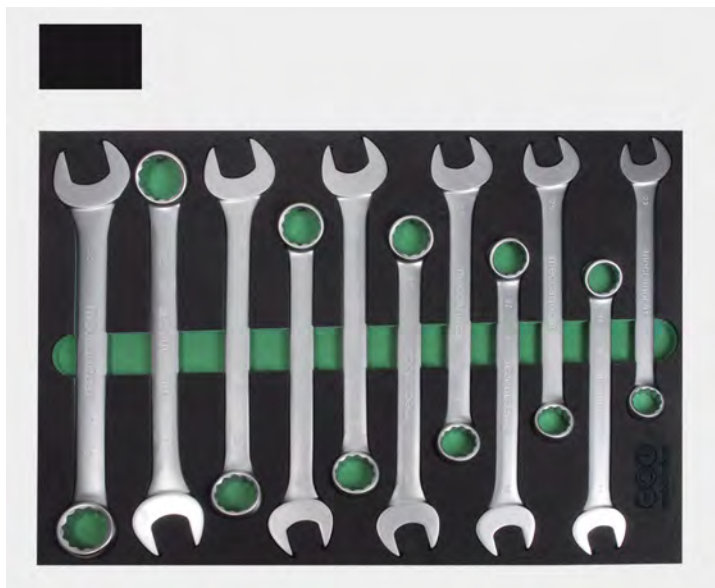

- In polietilene a bassa densità espanso.
- Formato 415x576mm 3/3 del cassetto.

Code	Desc.
4200004027	4027

CONTENUTO	
398 00 04027	termoformato vuoto 415x576
420 00 11023	23
420 00 11024	24
420 00 11025	25
420 00 11026	26
420 00 11027	27
420 00 11028	28
420 00 11029	29
420 00 11030	30
420 00 11032	32
420 00 11034	34
420 00 11036	36



## Fixed wrenches

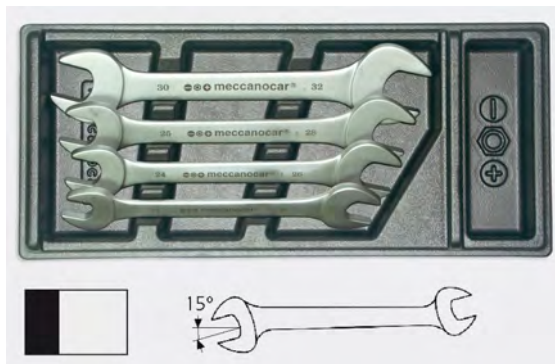

Code	Description/composition
4200003030	303 thermo full
3980003030	303 - thermal vacuum fixed wrenche 21x23-30x32
4200062123	6-21x23 chiave fissa
4200062426	6-24x26 Fixed wrenche
4200062528	6-25x28 Fixed wrenche
4200063032	6-30x32 Fixed wrenche

- Formato 415x188-1/3 cassetto.

## Thermo wrenches from 6x7 to 20x22

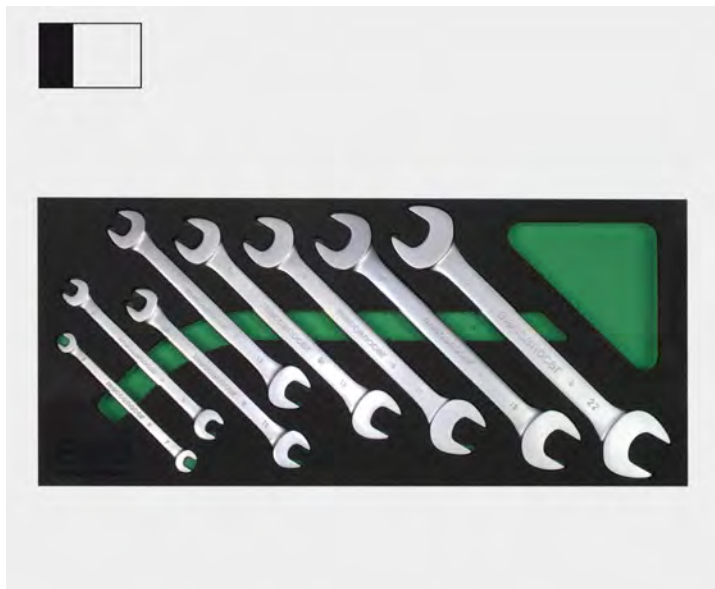

- In low density polyethylene foam.
- Format 415x188mm 1/3 drawer

Code	Desc.
4200004024	4024

CONTENUTO	
398 00 04024	termoformato vuoto 415x188
420 00 60607	6x7
420 00 60809	8x9
420 00 61011	10x11
420 00 61213	12x13
420 00 61415	14x15
420 00 61617	16x17
420 00 61819	18x19
420 00 62022	20x22

## Ring wrenches

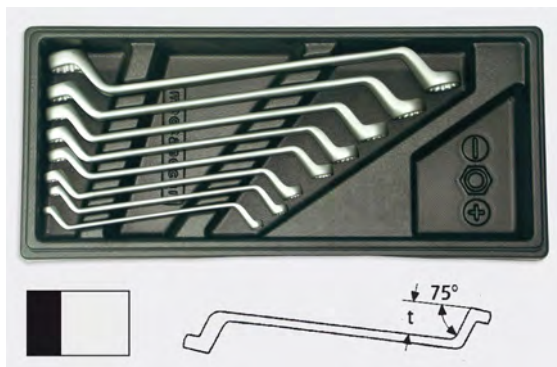

- Format 415x188-1 / 3 drawer.

Code	Description/composition
4200003040	304 thermo full
3980003040	304 - empty thermoformed wrench polygonal 6x7-20x22
4200020607	2-6x7 ring wrench
4200020809	2-8x9 ring wrench
4200021011	2-10x11 ring wrench
4200021213	2-12x13 ring wrench
4200021415	2-14x15 ring wrench
4200021617	2-16x17 ring wrench
4200021819	2-18x19 ring wrench
4200022022	2-20x22 ring wrench

## Ring wrenches

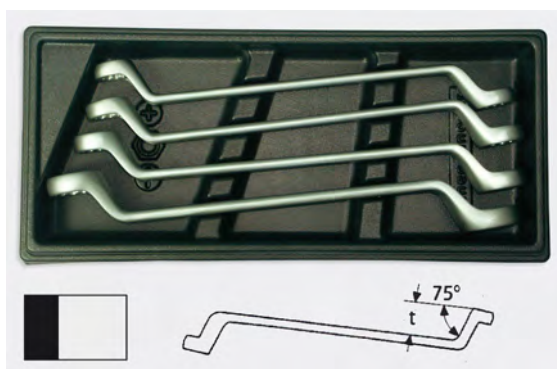

- Format 415x188-1 / 3 drawer.

Code	Description/composition
4200003050	305 thermo full
3980003050	305-thermoformed empty ring wrenches 21x23-30x32
4200022123	2-21x23 ring wrench
4200022427	2-24x27 ring wrench
4200022528	2-25x28 ring wrench
4200023032	2-30x32 ring wrench



## Thermo ring wrenches from 6x7 to 20x22

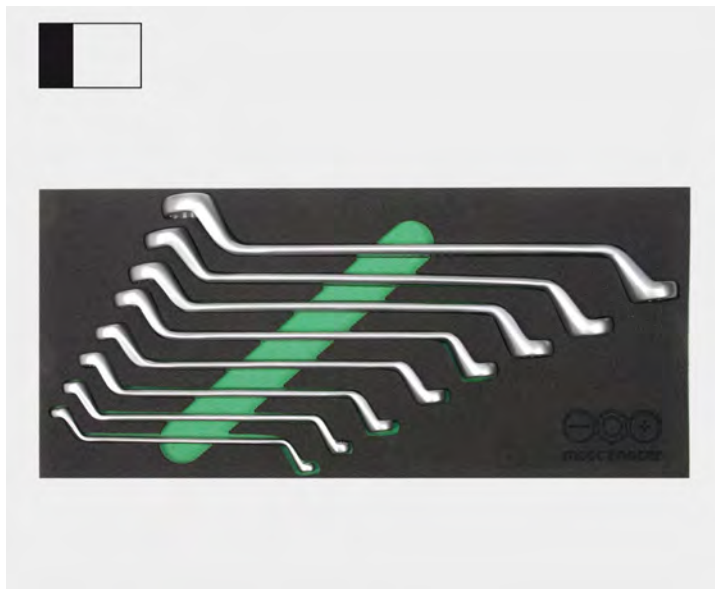

- In polietilene a bassa densità espanso.
- Formato 415x188mm 1/3 del cassetto.

Code	Desc.
4200004025	4025

CONTENUTO	
398 00 04025	termoformato vuoto 415x188
420 00 20607	6x7
420 00 20809	8x9
420 00 21011	10x11
420 00 21213	12x13
420 00 21415	14x15
420 00 21617	16x17
420 00 21819	18x19
420 00 22022	20x22

## Thermo ratchet combination wrenches 8 to 19

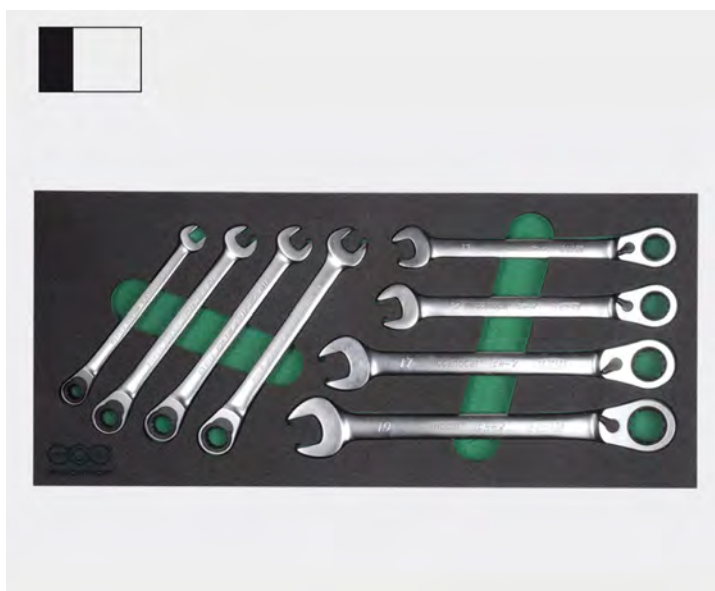

- In low density polyethylene foam.
- Format 415x188mm 1/3 drawer

Code	Desc.
4200004028	4028

CONTENUTO	
398 00 04028	termoformato vuoto 415x188
420 00 00390	8
420 00 00392	10
420 00 00394	11
420 00 00396	12
420 00 00398	13
420 00 00400	14
420 00 00406	17
420 00 00408	19

## Thermo accessories for sockets 1/4"

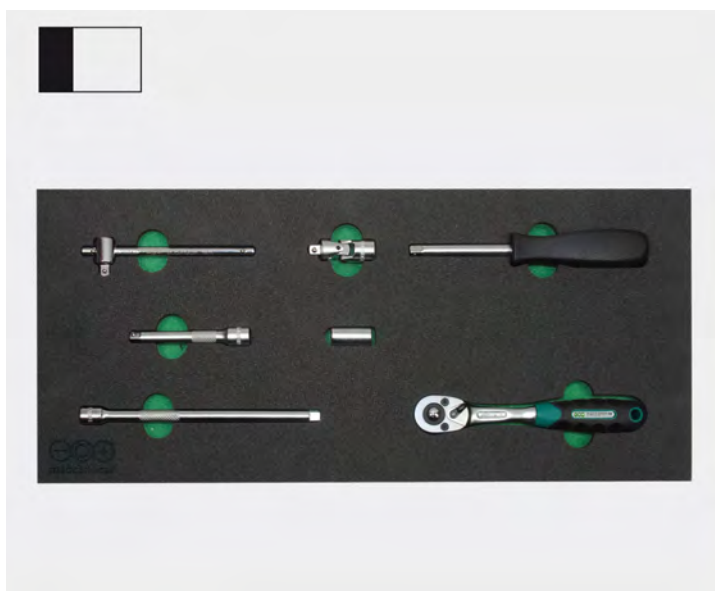

- In polietilene a bassa densità espanso.
- Formato :415x188 mm 1/3 del cassetto.

Code	Desc.
4200004001	4001

CONTENUTO	
398 00 04001	termoformato vuoto 415x188
420 00 00105	cricco 72d 1/4
420 00 00160	prolunga 75mm
420 00 00162	prolunga 150mm
420 00 00168	adattatore 1/4 ES 1/4
420 00 00164	snodo cardanico
420 00 00170	asta con attacco scorrevole
420 00 00166	portabussole



## Thermo hexagonal sockets 1/4" long and short

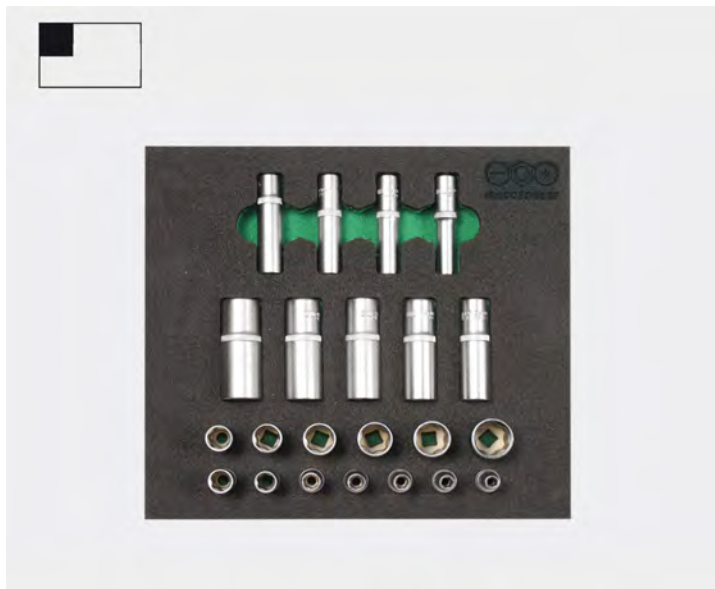

- In low density polyethylene foam.
- Size: 207x188mm 1/6 of the tray.

Code	Desc.
4200004002	4002

CONTENUTO		CONTENUTO	
398 00 04002	termoformato vuoto 207x188	420 00 00130	12
420 00 00110	4c bussola corta	420 00 00132	13
420 00 00112	4,5	420 00 00134	14
420 00 00114	5	420 00 00140	6L bussola lunga
420 00 00116	5,5	420 00 00142	7L
420 00 00118	6	420 00 00144	8L
420 00 00120	7	420 00 00146	9L
420 00 00122	8	420 00 00148	10L
420 00 00124	9	420 00 00150	11L
420 00 00126	10	420 00 00152	12L
420 00 00128	11	420 00 00154	13L
		420 00 00156	14L

## Thermo compasses polygonal 1/4 "long and short



- In low density polyethylene foam.
- Size: 207x188mm 1/6 of the tray.

Code	Desc.
4200004003	4003

CONTENUTO		CONTENUTO	
398 00 04003	termoformato vuoto 207x188	420 00 98814	14C
420 00 98804	5C bussola corta	420 00 98824	5L bussola lunga
420 00 98805	5,5C	420 00 98825	5,5L
420 00 98806	6C	420 00 98826	6L
420 00 98807	7C	420 00 98827	7L
420 00 98808	8C	420 00 98828	8L
420 00 98809	9C	420 00 98829	9L
420 00 98810	10C	420 00 98830	10L
420 00 98811	11C	420 00 98831	11L
420 00 98812	12C	420 00 98832	12L
420 00 98813	13C	420 00 98833	13L
		420 00 98834	14L

## Thermo 1/4" bushings short various profiles

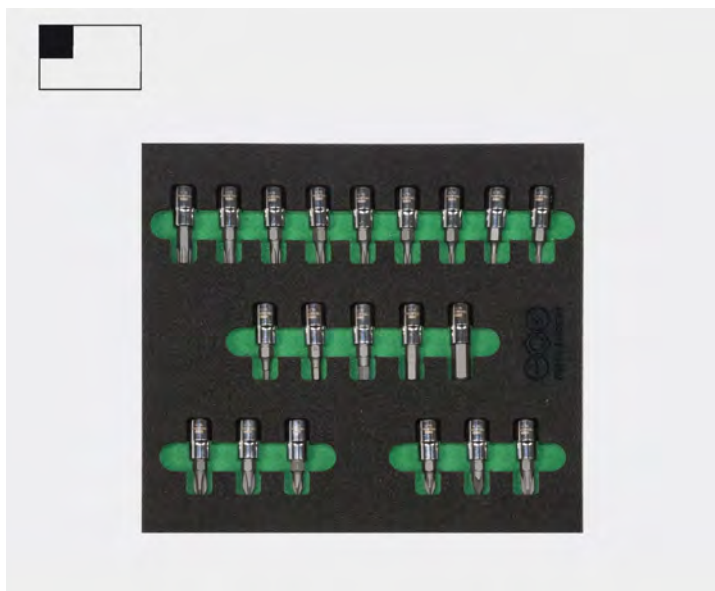

- In polietilene a bassa densità espanso.
- Formato :207x188mm 1/6 del cassetto

Code	Desc.
4200004004	4004

CONTENUTO		CONTENUTO	
398 00 04004	termoformato vuoto 207x188	420 00 98866	6ES
420 00 98841	PH1	420 00 98868	8ES
420 00 98842	PH2	420 00 98870	TX8
420 00 98843	PH3	420 00 98872	TX9
420 00 98851	PZ1	420 00 98874	TX10
420 00 98852	PZ2	420 00 98876	TX15
420 00 98853	PZ3	420 00 98878	TX20
420 00 98863	3ES	420 00 98880	TX25
420 00 98864	4ES	420 00 98882	TX27
420 00 98865	5ES	420 00 98884	TX30
		420 00 98886	TX40



## Termo accessori per bussole da 3/8"

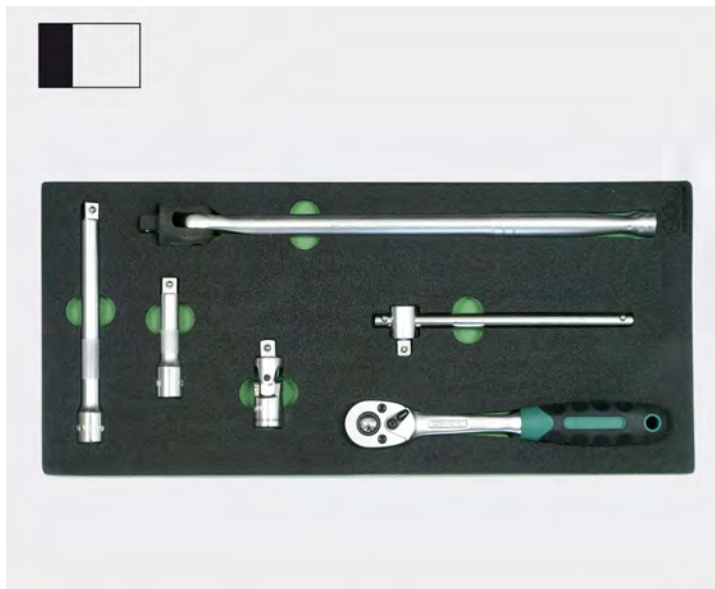

- In polietilene a bassa densità espanso.
- Formato :415x188 mm 1/3 del cassetto.

Code	Desc.
4200004005	4005

CONTENUTO	
398 00 04005	termoformato vuoto 415x188
420 00 00205	cricco 72d 3/8"
420 00 00284	prolunga 75mm
420 00 00285	prolunga 150mm
420 00 00288	impugnatura con snodo
420 00 00286	snodo cardanico
420 00 00287	asta con attacco scorrevole

## Thermo 3/8" hexagonal sockets short and long



- In polietilene a bassa densità espanso.
- Formato 415x188mm 1/3 del cassetto.

Code	Desc.
4200004006	4006

CONTENUTO		CONTENUTO	
398 00 04006	termoformato vuoto415x188	420 00 00264	22C
420 00 00250	8C bussola corta	420 00 00265	23C
420 00 00251	9C	420 00 00266	24C
420 00 00252	10C	420 00 00270	8L bussola lunga
420 00 00253	11C	420 00 00271	9L
420 00 00254	12C	420 00 00272	10L
420 00 00255	13C	420 00 00273	11L
420 00 00256	14C	420 00 00274	12L
420 00 00257	15C	420 00 00275	13L
420 00 00258	16C	420 00 00276	14L
420 00 00259	17C	420 00 00277	15L
420 00 00260	18C	420 00 00278	16L
420 00 00261	19C	420 00 00279	17L
420 00 00262	20C	420 00 00280	18L
420 00 00263	21C	420 00 00281	19L

## Thermo 3/8 "socket wrenches polygonal short + long



- In polietilene a bassa densità espanso.
- Formato :415x188 mm 1/3 del cassetto.

Code	Desc.
4200004009	4009

CONTENUTO		CONTENUTO	
398 00 04009	termoformato vuoto415x188	420 00 98937	7L bussola lunga
420 00 98908	8C bussola corta	420 00 98938	8L
420 00 98909	9C	420 00 98939	9L
420 00 98910	10C	420 00 98940	10L
420 00 98911	11C	420 00 98941	11L
420 00 98912	12C	420 00 98942	12L
420 00 98913	13C	420 00 98943	13L
420 00 98914	14C	420 00 98944	14L
420 00 98915	15C	420 00 98945	15L
420 00 98916	16C	420 00 98946	16L
420 00 98917	17C	420 00 98947	17L
420 00 98918	18C	420 00 98948	18L
420 00 98919	19C	420 00 98949	19L
420 00 98920	20C	420 00 98950	20L
420 00 98921	21C	420 00 98951	21L
420 00 98922	22C	420 00 98952	22L



## Thermo 3/8" hexagonal sockets male c + l



- In polietilene a bassa densità espanso.
- Formato 415x188mm 1/3 del cassetto.

Code	Desc.
4200004007	4007

CONTENUTO	
<b>398 00 04007</b>	<b>termoformato vuoto 415x188</b>
<b>420 00 00212</b>	<b>4L 48 bussola corta</b>
<b>420 00 00213</b>	<b>5L</b>
<b>420 00 00214</b>	<b>6L</b>
<b>420 00 00215</b>	<b>7L</b>
<b>420 00 00216</b>	<b>8L</b>
<b>420 00 00217</b>	<b>9L</b>
<b>420 00 00218</b>	<b>10L</b>
<b>420 00 00220</b>	<b>12L</b>
<b>420 00 00221</b>	<b>4L140 bussola lunga</b>
<b>420 00 00222</b>	<b>5L</b>
<b>420 00 00223</b>	<b>6L</b>
<b>420 00 00224</b>	<b>7L</b>
<b>420 00 00225</b>	<b>8L</b>
<b>420 00 00226</b>	<b>9L</b>
<b>420 00 00227</b>	<b>10L</b>
<b>420 00 00228</b>	<b>12L</b>

## Thermo 1/2 "socket wrenches Torx female long series



- In low density polyethylene foam.
- Format: 207x188mm 1/6 drawer

Code	Desc.
4200004019	4019

CONTENUTO	
<b>398 00 04019</b>	<b>termoformato vuoto 207x188</b>
<b>443 00 47560</b>	<b>E10 bussola lunga</b>
<b>443 00 47562</b>	<b>E12</b>
<b>443 00 47564</b>	<b>E14</b>
<b>443 00 47566</b>	<b>E16</b>
<b>443 00 47568</b>	<b>E18</b>
<b>443 00 47570</b>	<b>E20</b>

## Thermo accessories for sockets 1/2"



- In low density polyethylene foam.
- Format: 415x188 mm 1/3 drawer.

Code	Desc.
4200004010	4010

CONTENUTO	
<b>398 00 04010</b>	<b>termoformato vuoto 415x188</b>
<b>420 00 00305</b>	<b>cricco 72d 1/2"</b>
<b>420 00 00379</b>	<b>prolunga 75mm</b>
<b>420 00 00380</b>	<b>prolunga 125mm</b>
<b>420 00 00382</b>	<b>prolunga 250mm</b>
<b>420 00 00384</b>	<b>snodo cardanico</b>
<b>420 00 00386</b>	<b>impugnatura con snodo</b>
<b>420 00 00518</b>	<b>asta con attacco scorrevole</b>



## Thermo sockets 1/2" hexagonal short

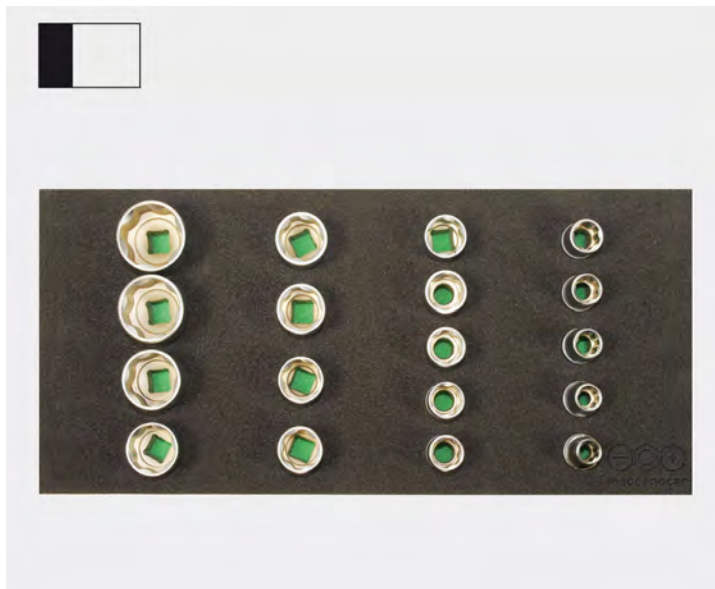

- In low density polyethylene foam.
- Format 415x188mm 1/3 of the tray.

Code	Desc.
4200004011	4011

CONTENUTO	
398 00 04011	termoformato vuoto 415x188
420 00 00360	10C bussola corta
420 00 00361	11C
420 00 00362	12C
420 00 00363	13C
420 00 00364	14C
420 00 00365	15C
420 00 00366	16C
420 00 00367	17C
420 00 00368	18C
420 00 00369	19C
420 00 00370	20C
420 00 00371	21C
420 00 00372	22C
420 00 00373	23C
420 00 00374	24C
420 00 00375	27C
420 00 00376	30C
420 00 00377	32C

## Thermo 1/2 " hexagonal socket wrenches long



- In polietilene a bassa densità espanso.
- Formato 415x188mm 1/3 del cassetto.

Code	Desc.
4200004012	4012

CONTENUTO	
398 00 04012	termoformato vuoto 415x188
420 00 98960	10L bussola lunga
420 00 98961	11L
420 00 98962	12L
420 00 98963	13L
420 00 98964	14L
420 00 98965	15L
420 00 98966	16L
420 00 98967	17L
420 00 98968	18L
420 00 98969	19L
420 00 98971	21L
420 00 98972	22L
420 00 98973	23L
420 00 98974	24L
420 00 98976	26L
420 00 98977	27L
420 00 98978	28L
420 00 98979	29L
420 00 98980	30L
420 00 98982	32L

## Thermo 1/2 "socket wrenches polygona short



- In low density polyethylene foam.
- Format 415x188mm 1/3 of the tray.

Code	Desc.
4200004013	4013

CONTENUTO		CONTENUTO	
398 00 04013	termoformato vuoto 415x188	420 00 99000	20C
420 00 98990	10C bussola corta	420 00 99021	21C
420 00 98991	11C	420 00 99022	22C
420 00 98992	12C	420 00 99023	23C
420 00 98993	13C	420 00 99024	24C
420 00 98994	14C	420 00 99025	25C
420 00 98995	15C	420 00 99026	26C
420 00 98996	16C	420 00 99027	27C
420 00 98997	17C	420 00 99028	28C
420 00 98998	18C	420 00 99029	29C
420 00 98999	19C	420 00 99030	30C
		420 00 99032	32C



## Thermo 1/2 " socket wrenches polygonal long



- In low-density polyethylene foam
- Format: 415x188 mm 1/3 drawer.

Code	Desc.
4200004014	4014

CONTENUTO	
398 00 04014	termoformato vuoto 415x188
420 00 99040	10L bussola lunga
420 00 99041	11L
420 00 99042	12L
420 00 99043	13L
420 00 99044	14L
420 00 99045	15L
420 00 99046	16L
420 00 99047	17L
420 00 99048	18L
420 00 99049	19L
420 00 99051	21L
420 00 99052	22L
420 00 99053	23L
420 00 99054	24L
420 00 99056	26L
420 00 99057	27L
420 00 99057	28L
420 00 99059	29L
420 00 99060	30L
420 00 99062	32L

## Thermo 1/2 "socket wrenches hexagonal male short + long

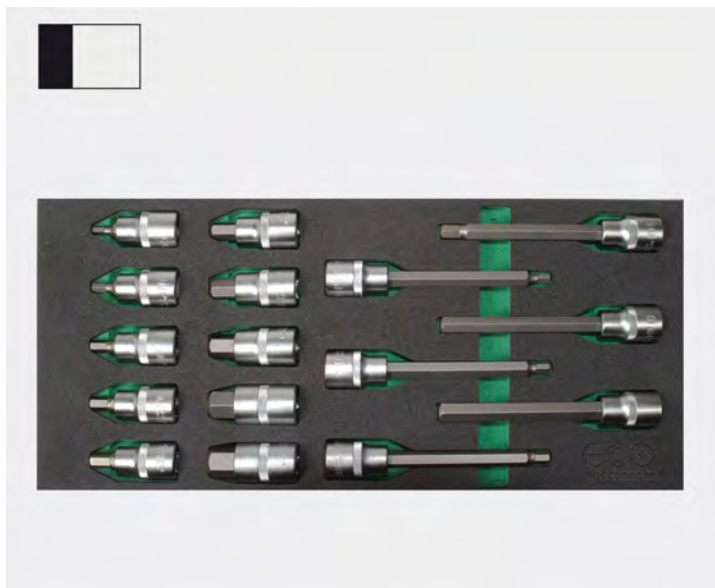

- In low density polyethylene foam.
- Format 415x188mm 1/3 drawer

Code	Desc.
4200004015	4015

CONTENUTO	
398 00 04015	termoformato vuoto 415x188
420 00 00312	5L 55 bussola corta
420 00 00313	6L
420 00 00314	7L
420 00 00315	8L
420 00 00316	9L
420 00 00317	10L
420 00 00318	12L
420 00 00319	14L
420 00 00320	17L
420 00 00321	19L
420 00 00323	5L 140 bussola lunga
420 00 00324	6L
420 00 00325	7L
420 00 00326	8L
420 00 00327	10L
420 00 00328	12L

## Thermo 1/2" socket wrenches Torx male short + long



- In low density polyethylene foam.
- Format 415x188mm 1/3 drawer

Code	Desc.
4200004016	4016

CONTENUTO	
398 00 04016	termoformato vuoto 415x188
420 00 00332	T15L 55 bussola corta
420 00 00333	T20
420 00 00334	T25
420 00 00335	T27
420 00 00336	T30
420 00 00337	T40
420 00 00338	T45
420 00 00339	T50
420 00 00340	T55
420 00 00341	T60
420 00 00343	T15 L140 bussola lunga
420 00 00344	T20
420 00 00345	T25
420 00 00346	T27
420 00 00347	T30
420 00 00348	T40
420 00 00349	T45
420 00 00350	T50
420 00 00351	T55
420 00 00352	T60



## Thermo 1/2 "socket wrenches XZN profile male



- In polietilene a bassa densità espanso.
- Formato :207x188mm 1/6 del cassetto

Code	Desc.
4200004017	4017

CONTENUTO	
398 00 04017	termoformato vuoto207x188
420 00 99075	M5C bussola corta
420 00 99076	M6C
420 00 99078	M8C
420 00 99080	M10C
420 00 99082	M12C
420 00 99084	M14C
420 00 99096	M6L bussola lunga
420 00 99098	M8L
420 00 99100	M10L
420 00 99102	M12L

## Thermo 1/2" socket wrenches profile long ribe

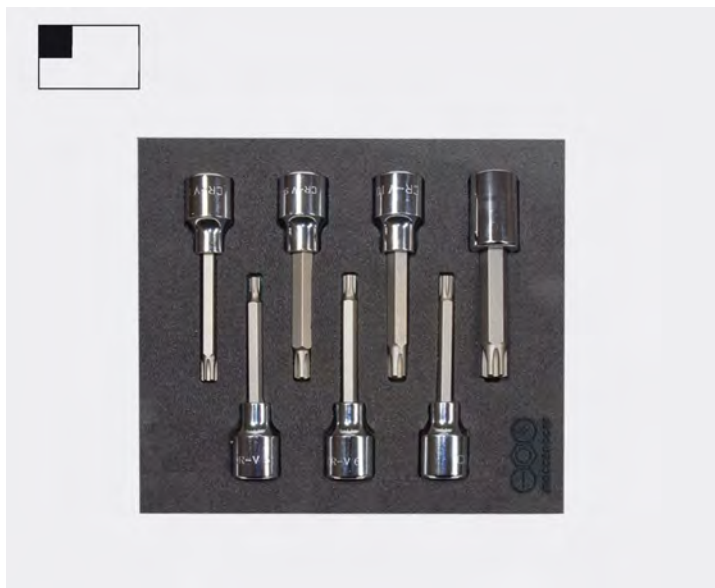

- In low density polyethylene foam.
- Format: 207x188mm 1/6 drawer

Code	Desc.
4200004018	4018

CONTENUTO	
398 00 04018	termoformato vuoto207x188
420 00 99105	M5L bussola lunga
420 00 99106	M6L
420 00 99107	M7L
420 00 99108	M8L
420 00 99109	M9L
420 00 99110	M10L
420 00 99112	M12L

## Thermo 3/4" socket wrenches hexagonal short



- In low density polyethylene foam.
- Format 415x376mm 2/3 of the tray.

Code	Desc.
4200004021	4021

CONTENUTO		CONTENUTO	
398 00 04021	termoformato vuoto 415x376	420 00 99133	33C
420 00 99119	19C bussola corta	420 00 99134	34C
420 00 99121	21C	420 00 99135	35C
420 00 99122	22C	420 00 99136	36C
420 00 99123	23C	420 00 99138	38C
420 00 99124	24C	420 00 99140	40C
420 00 99125	25C	420 00 99141	41C
420 00 99126	26C	420 00 99142	42C
420 00 99127	27C	420 00 99146	46C
420 00 99128	28C	420 00 99150	50C
420 00 99129	29C	420 00 99154	54C
420 00 99130	30C	420 00 99155	55C
420 00 99132	32C	420 00 99160	60C





## Thermo 3/4" socket wrenches polygonal short



- In low density polyethylene foam.
- Format 415x376mm 2/3 of the tray.

Code	Desc.
4200004022	4022

CONTENUTO		CONTENUTO	
<b>398 00 04022</b>	<b>termoformato vuoto 415x376</b>	<b>420 00 99233</b>	<b>33C</b>
<b>420 00 99219</b>	<b>19C bussola corta</b>	<b>420 00 99234</b>	<b>34C</b>
<b>420 00 99221</b>	<b>21C</b>	<b>420 00 99235</b>	<b>35C</b>
<b>420 00 99222</b>	<b>22C</b>	<b>420 00 99236</b>	<b>36C</b>
<b>420 00 99223</b>	<b>23C</b>	<b>420 00 99238</b>	<b>38C</b>
<b>420 00 99224</b>	<b>24C</b>	<b>420 00 99240</b>	<b>40C</b>
<b>420 00 99225</b>	<b>25C</b>	<b>420 00 99241</b>	<b>41C</b>
<b>420 00 99226</b>	<b>26C</b>	<b>420 00 99242</b>	<b>42C</b>
<b>420 00 99227</b>	<b>27C</b>	<b>420 00 99244</b>	<b>44C</b>
<b>420 00 99228</b>	<b>29C</b>	<b>420 00 99246</b>	<b>46C</b>
<b>420 00 99230</b>	<b>30C</b>	<b>420 00 99250</b>	<b>50C</b>
<b>420 00 99232</b>	<b>32C</b>	<b>420 00 99254</b>	<b>54C</b>
		<b>420 00 99255</b>	<b>55C</b>

## Thermo screwdrivers 7 pieces "Easy" to cut

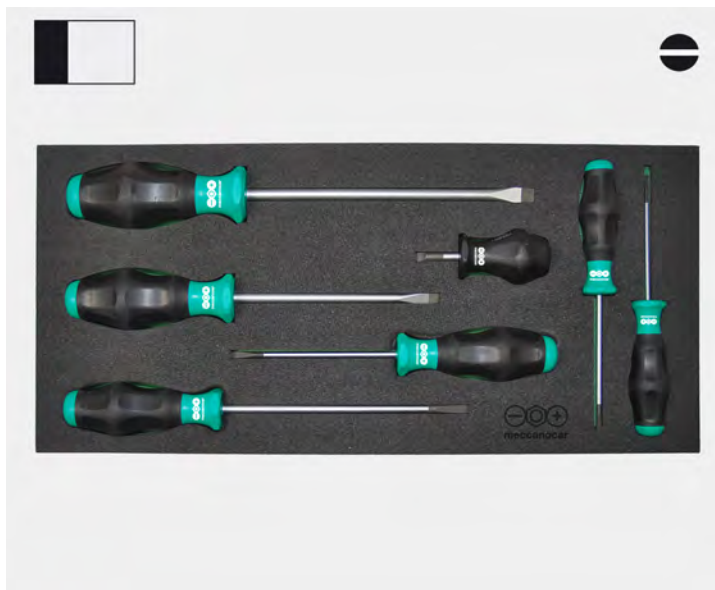

- In low density polyethylene foam, resistant to oils and greases.
- Format 415 x 188 1/3 drawer of a cart Meccanocar

Code	Description
4200004052	4052 thermo-7 pieces Easy

Contenuto 4200004052

CODICE	DESCRIZIONE
3980004052	Termoformato vuoto
4200100205	1335-2.5x75
4200100210	1335-3x80
4200100215	1335-4x100
4200100220	1335-5.5x150
4200100225	1334-6x125
4200100230	1334-8x175
4200100240	110070-5.5x25 nano

## Thermo 6 pieces screwdrivers "Big" Shear

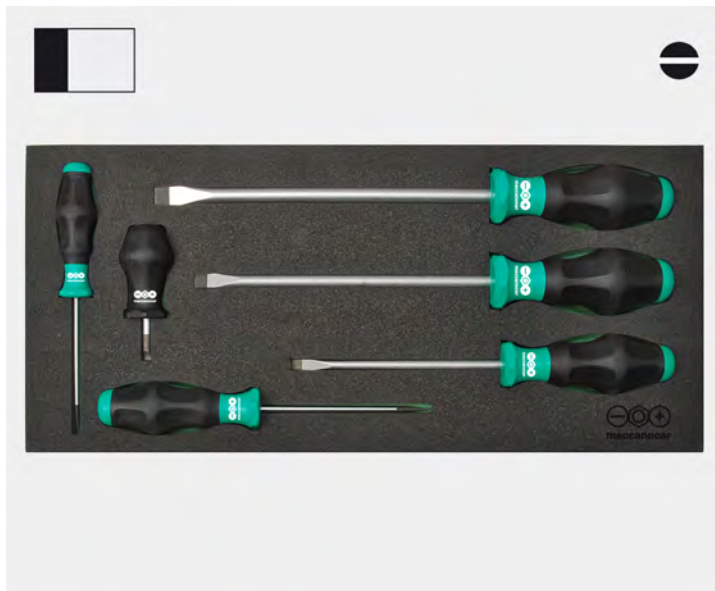

- In low density polyethylene foam, resistant to oils and greases.
- Format 415 x 188 1/3 drawer of a cart Meccanocar

Code	Description
4200004053	4053-Thermo 6 pieces Big

Contenuto 4200004053

CODICE	DESCRIZIONE
3980004053	Termoformato vuoto
4200100210	1335-3x80
4200100215	1335-4x100
4200100225	1334-6x125
4200100230	1334-8x175
4200100235	1334-10x200
4200100240	110070-5.5x25 nano

## Thermo screwdrivers 7 crosspieces Bottom footprint PH Phillips

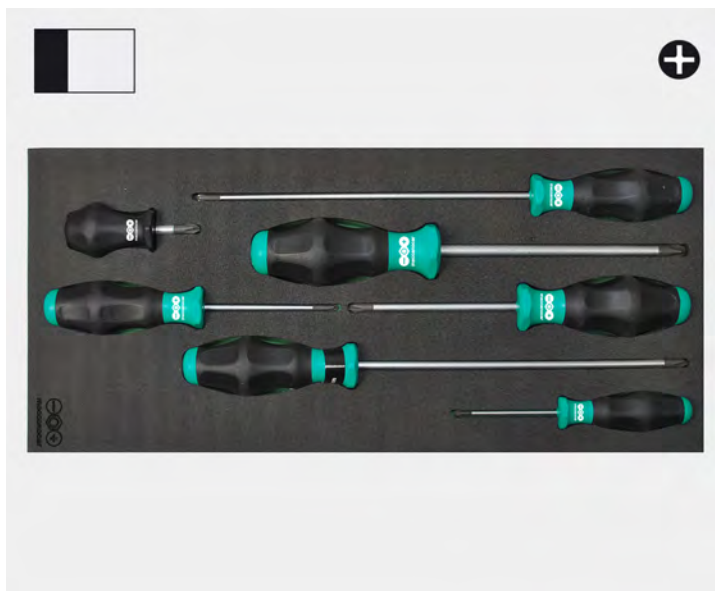

- In polietilene espanso a bassa densità, resistenti ad olio e grassi.
- Formato 415 x 188 1/3 del cassetto di un carrello Meccanocar

Code	Description
4200004054	4054 thermo-7 pieces PH

### Contenuto 4200004054

CODICE	DESCRIZIONE
3980004054	Termoformato vuoto
4200100255	1350-PH0
4200100260	1350-PH1
4200100265	1350-PH1 x200
4200100270	1350-PH2
4200100275	1350-PH2x200
4200100280	1350-PH3
4200100250	008780-PH2

## Thermo 7 piece Torx screwdrivers

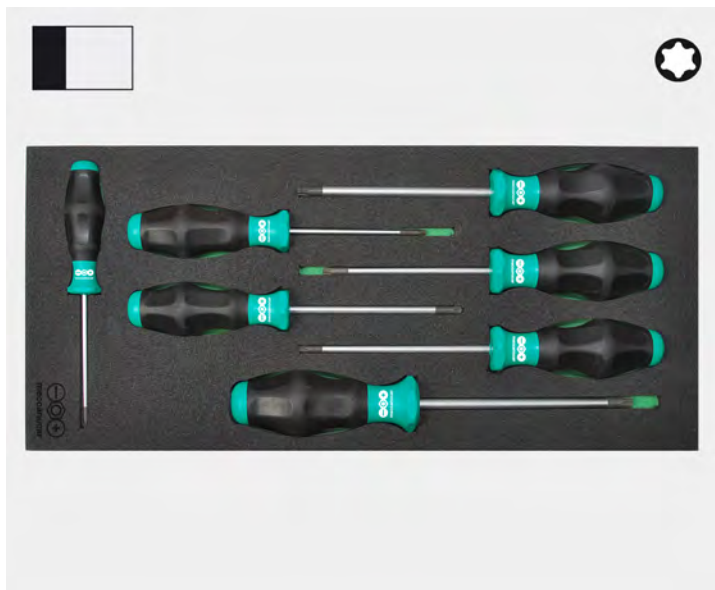

- In low density polyethylene foam, resistant to oils and greases.
- Format 415 x 188 1/3 drawer of a cart Meccanocar

Code	Description
4200004055	4055 thermo-7 piece Torx

### Contenuto 4200004055

CODICE	DESCRIZIONE
3980004055	Termoformato vuoto
4200100305	1367-TX10
4200100310	1367-TX15
4200100315	1367-TX20
4200100320	1367-TX25
4200100325	1367-TX27
4200100330	1367-TX30
4200100335	1367-TX40

## Thermo screwdrivers 7 pieces mixed cross-cutting + PH Phillips

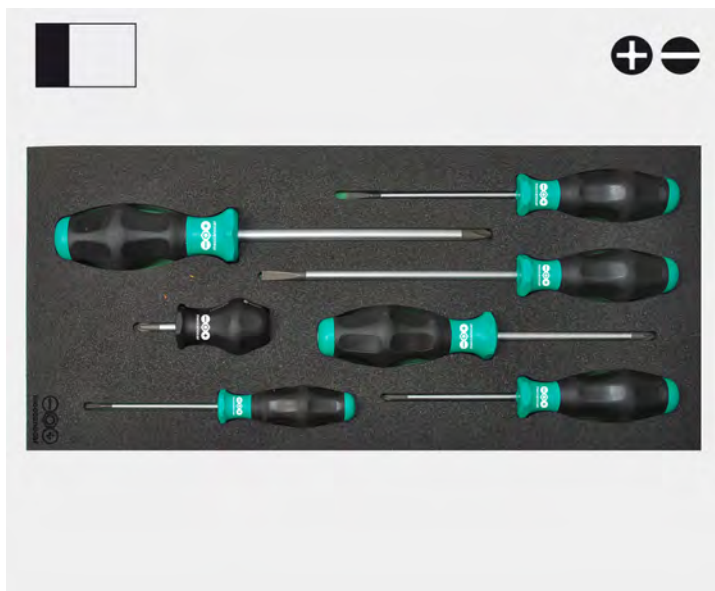

- In low density polyethylene foam, resistant to oils and greases.
- Format 415 x 188 1/3 drawer of a cart Meccanocar

Code	Description
4200004056	4056 thermo-7 pieces + cutting cross PH

### Contenuto 4200004056

CODICE	DESCRIZIONE
3980004056	Termoformato vuoto
4200100210	1335-3x80
4200100215	1335-4x100
4200100220	1335-5,5x150
4200100260	1350-PH1
4200100270	1350-PH2
4200100280	1350-PH3
4200100245	008775-PH 1 nano

## Thermo keys "T" 6-piece Torx

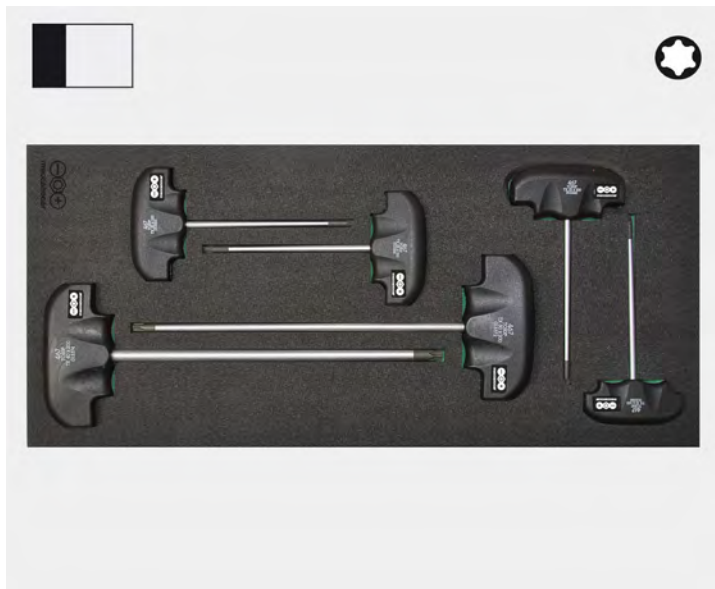

- In low density polyethylene foam, resistant to oils and greases.
- Format 415 x 188 1/3 drawer of a cart Meccanocar

Code	Description
4200004057	4057 thermo-6 key pieces in "T" Torx

### Contenuto 4200004057

CODICE	DESCRIZIONE
3980004057	Termoformato vuoto
4200100475	467-TX10
4200100480	467-TX15
4200100485	467-TX20
4200100490	467-TX25
4200100500	467-TX30
4200100505	467-TX40

## Thermo keys "T" 6 pieces Hexagonal male

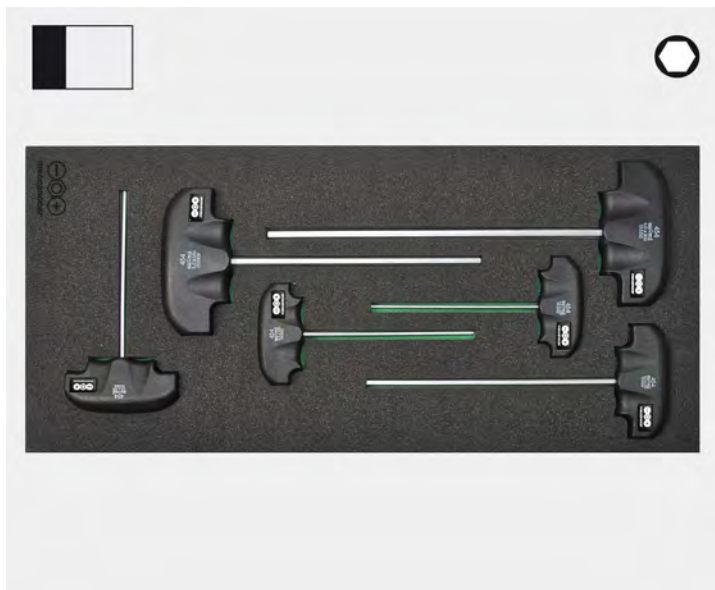

- In low density polyethylene foam, resistant to oils and greases.
- Format 415 x 188 1/3 drawer of a cart Meccanocar

Code	Description
4200004058	4058 thermo-6 key pieces in "T" Es.

### Contenuto 4200004058

CODICE	DESCRIZIONE
3980004058	Termoformato vuoto
4200100435	454-2
4200100440	454-2,5
4200100445	454-3
4200100450	454-4
4200100455	454-5
4200100460	454-6



## Thermo bits 1/4" + brings magnetic bits

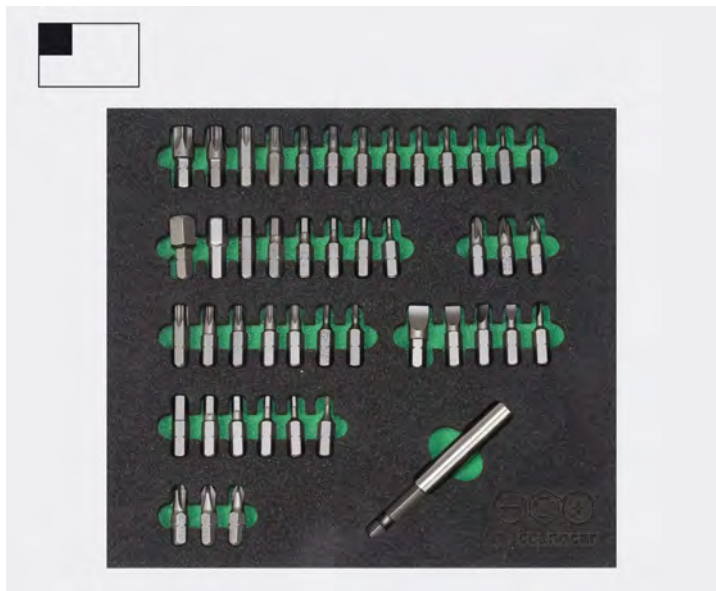

- In polietilene a bassa densità espanso.
- Formato 207x188mm 1/6 del cassetto.

Code	Desc.
4200004050	4050

CONTENUTO		CONTENUTO	
398 00 04050	termoformato vuoto 207x188mm	443 00 46750	Tx10
443 00 25100	3 taglio	443 00 46752	Tx15
443 00 25110	4	443 00 46754	Tx20
443 00 25130	5	443 00 46756	Tx25
443 00 25150	6	443 00 46758	Tx27
443 00 25170	8	443 00 46760	Tx30
443 00 25200	1 ph	443 00 46762	Tx40
443 00 25210	2	443 00 46764	Tx45
443 00 25220	3	443 00 46766	Tx50
443 00 46620	1 pz	443 00 46770	Tx10 con foro
443 00 46622	2	443 00 46772	Tx15
443 00 46624	3	443 00 46774	Tx20
443 00 46624	3	443 00 46776	Tx25
443 00 46676	2 esagonale m	443 00 46778	Tx27
443 00 46678	2,5	443 00 46780	Tx30
443 00 46680	3	443 00 46782	Tx40
443 00 46682	4	443 00 50860	2 es con foro
443 00 46684	5	443 00 50862	2,5
443 00 46686	6	443 00 50864	3
443 00 46690	8	443 00 50866	4
443 00 46692	10	443 00 50868	5
443 00 46742	Tx6 torx m	443 00 50870	6
443 00 46744	Tx7	443 00 44640	porta bits magnetico
443 00 46746	Tx8		
443 00 46748	Tx9		

## Thermo bits 3/8"+ 2 compasses brings bits

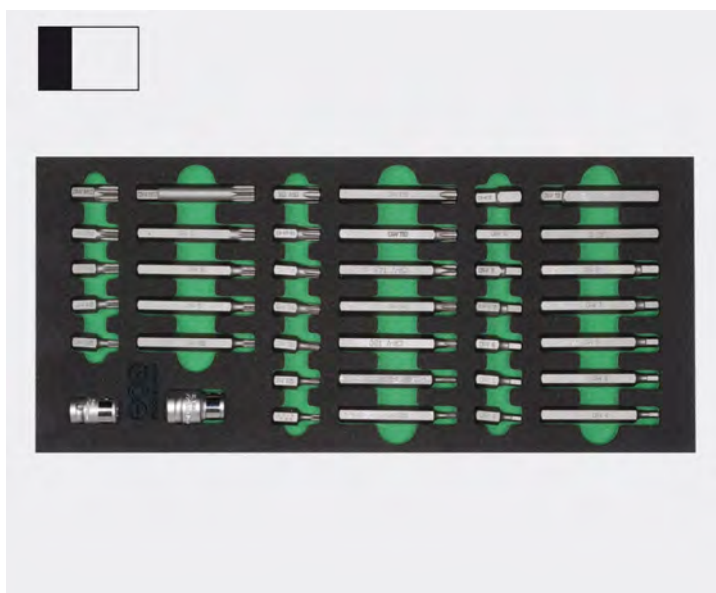

- In low density polyethylene foam.
- Format 415x188mm 1/3 of the tray.

Code	Desc.
4200004043	4043

CONTENUTO		CONTENUTO	
398 00 04043	termoformato vuoto 415x188mm	443 00 42575	5
443 00 42510	4-130 esagonale	443 00 42580	6
443 00 42520	5	443 00 42572	7
443 00 42530	6	443 00 42585	8
443 00 42540	7	443 00 42590	10
443 00 42550	8	443 00 42592	12
443 00 42560	10	443 00 44310	Tx20
443 00 42570	12	443 00 44312	Tx25
443 00 44400	Tx20 130 torx	443 00 44316	Tx30
443 00 44401	tx25	443 00 44318	Tx40
443 00 44402	tx30	443 00 44320	Tx45
443 00 44403	tx40	443 00 44322	Tx50
443 00 44404	tx45	443 00 44324	Tx55
443 00 44405	tx50	443 00 44528	5x22 175
443 00 44406	tx55	443 00 44530	6
443 00 44480	5 x22 130	443 00 44540	8
443 00 44490	6	443 00 44550	10
443 00 44500	8	443 00 44560	12
443 00 44510	10	443 00 44570	3/8-1/2 bussola porta bits
443 00 44520	12	443 00 47806	3/8-3/8 bussola porta bits
443 00 42574	4-175 esagonale		

## Thermo mixed batch



- In low density polyethylene foam.
- Format 415x188mm 1/3 drawer

Code	Desc.
4200004038	4038

CONTENUTO	
398 00 04038	termoformato vuoto 415x188mm
420 00 98510	185 pinza combinata
443 00 55155	250 chiave a rullino
443 00 02606	190 cesoia multiuso

## Thermo pliers



- In low density polyethylene foam.
- Format 415x376mm 2/3 of the tray.

Code	Desc.
4200004035	4035

CONTENUTO	
398 00 04035	termoformato vuoto 415x376mm
420 00 41180	180 pinza universale
420 00 15160	160 pinza b.1/2 tondi diritti
420 00 15200	200 pinza b.1/2 tondi diritti
420 00 17160	160 pinza b.1/2 tondi piegati
420 00 17200	200 pinza b.1/2 tondi piegati
420 00 05160	160 pinza b. piatti diritti
420 00 29160	160 tronchese taglio diagonale
420 00 33200	200 tronchese forte taglio diagonale
420 00 37160	160 tronchese forte taglio frontale

## Thermo Seeger pliers for inner and outer rings

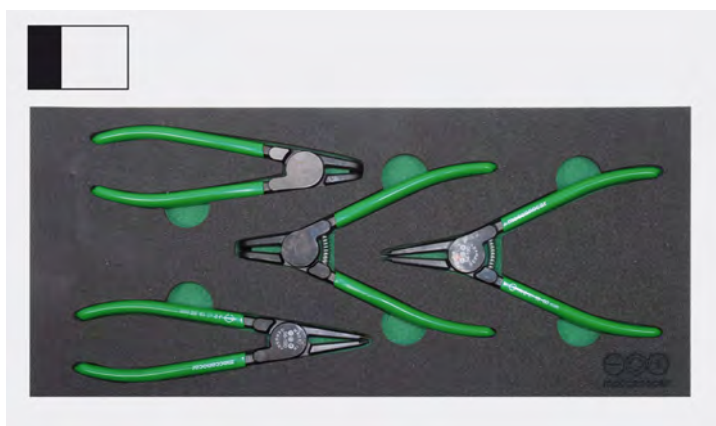

- In low density polyethylene foam.
- Format 415x188mm 1/3 of the tray.

Code	Desc.
4200004023	4023

CONTENUTO	
398 00 04023	termoformato vuoto 415x188
420 00 54190	A2
420 00 55190	A21
420 00 56190	J2
420 00 57190	J21

## Thermo series pliers mixed



- In low density polyethylene foam.
- Format 415x188mm 1/3 drawer

Code	Desc.
4200004036	4036

CONTENUTO	
398 00 04036	termoformato vuoto 415x188mm
420 00 77240	240 pinza poligrip a cerniera chiusa
420 00 93250	250 tenaglia
443 00 49285	250 pinza grip con tagliente



## Thermo hammers



- In polietilene a bassa densità espanso.
- Formato 415x188mm 1/3 del cassetto.

Code	Desc.
4200004037	4037

CONTENUTO	
398 00 04037	termoformato vuoto 415x188mm
443 00 13400	35 mazzuola teste in plastica
443 00 45640	500 martello
443 00 45740	800 mazzetta

## Thermo mixed batch chisels, punches and punch

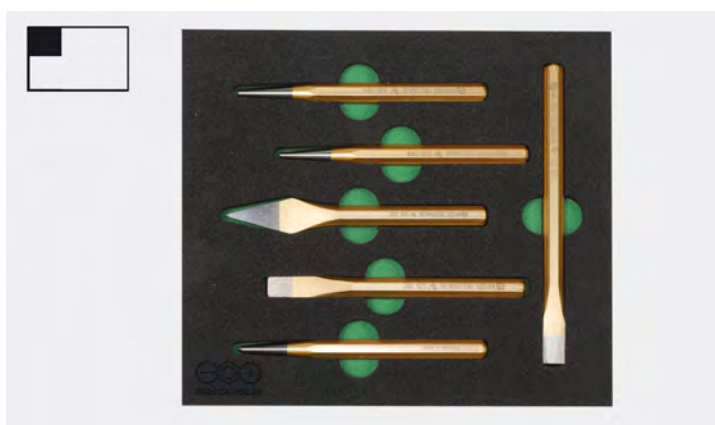

- In polietilene a bassa densità espanso.
- Formato 207x188mm 1/6 del cassetto

Code	Desc.
4200004047	4047

CONTENUTO	
398 00 04047	termoformato vuoto 207x188mm
443 00 56300	10x125 scalpello
443 00 56305	10x150 scalpello
443 00 56310	10x125 scalpello a punta
443 00 56335	4x120 punteruolo
443 00 56345	3x120 punzone
443 00 56346	4x120 punzone

## Thermo series mixed punches and awls

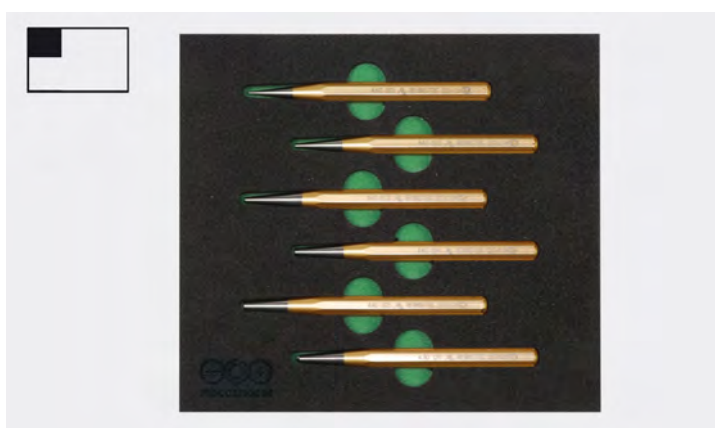

- In low density polyethylene foam.
- Format 207x188mm 1/6 of the tray.

Code	Desc.
4200004048	4048

CONTENUTO	
398 00 04048	termoformato vuoto 207x188mm
443 00 56343	1x120 punzone
443 00 56344	2x120
443 00 56345	3x120
443 00 56346	4x120
443 00 56347	5x120
443 00 56335	4x120 punteruolo

## Thermo hunting pins



- In low density polyethylene foam.
- Format 207x188mm 1/6 of the tray.

Code	Desc.
4200004049	4049

CONTENUTO	
398 00 04049	termoformato vuoto 207x188mm
443 00 56360	150x3 cacciaspina
443 00 56365	150x4
443 00 56370	150x5
443 00 56375	150x6
443 00 56380	150x8
443 00 56385	150x10

## New thermoformed items for the new Meccanocar trolleys

- Thermoformed items made in Plastazote, that is a soft material resistant to greases and oils.
- Black-coloured
- Produced in four different formats to create the various combinations of tools selection to solve the requirements of every customer of ours.
- Suitable for drawers having minimum width of 530 mm and minimum height of 370 mm.
- Thermo three-head wrenches + M12 Allen wrench 1/2 format of the drawer
- Size 265x370 mm

### Thermo three-head wrenches + M12 Allen wrench

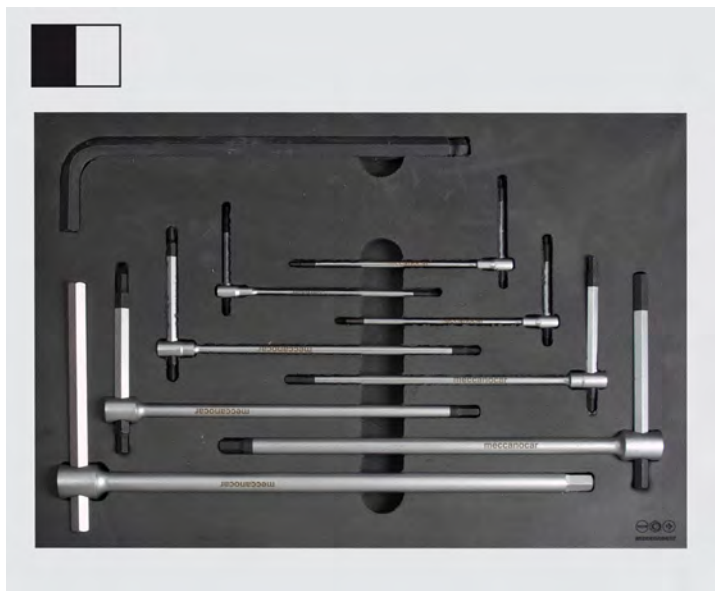

- Made of Plastazote, a soft material resistant to fats and oils.
- 1/2 format of the drawer
- **Size 265x370 mm**

Code	Description
420005000	5000-THERMO 3-HEAD WRENCHES+M12

**Contenuto:**

CODICE	DESCRIZIONE
4200058902	2-chiave a "T" a 3 teste
4200058925	2,5-chiave a "T" a 3 teste
4200058903	3-chiave a "T" a 3 teste
4200058904	4-chiave a "T" a 3 teste
4200058905	5-chiave a "T" a 3 teste
4200058906	6-chiave a "T" a 3 teste
4200058908	8-chiave a "T" a 3 teste
4200058910	10-chiave a "T" a 3 teste
4430058520	12-brugola T sferica
3980005000	5000-termo vuoto 1/2

8

### Termo Chiavi a T snodate + chiavi a brugola esagonali e torx - 25 Pz.

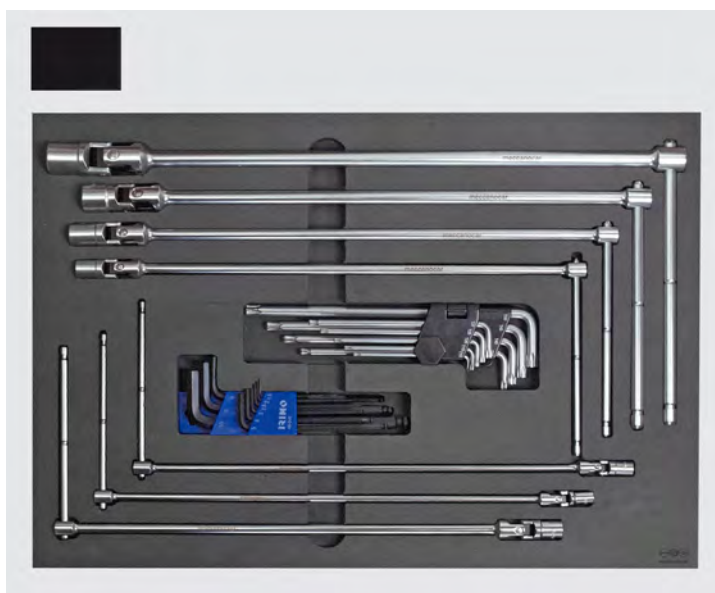

- Made of Plastazote, a soft material resistant to fats and oils.

Code	Description
420005020	5020-TERMO CH.T SNODATE+BRUGOLE

**Contenuto:**

CODICE	DESCRIZIONE
4200027107	7- chiave a "T" snodata
4200027108	8- chiave a "T" snodata
4200027110	10- chiave a "T" snodata
4200027111	11- chiave a "T" snodata
4200027113	13- chiave a "T" snodata
4200027117	17- chiave a "T" snodata
4200027119	19- chiave a "T" snodata
4430045425	Serie brugole
4770000960	Serie brugole torx
3980005020	Termo vuoto

### Thermo spanners from 6x7 to 20x22 - 8 Pc.

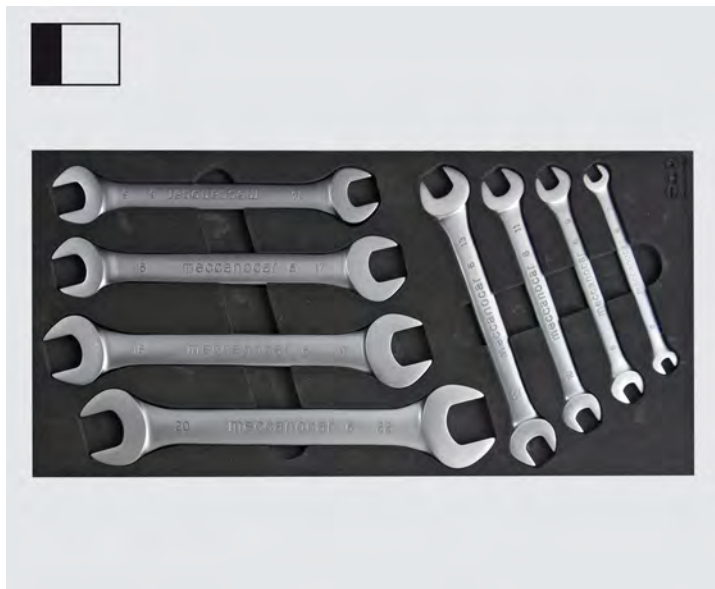

- Thermo spanners from 21x23 to 30x32
- 1/2 format of the drawer
- **Size 265x370 mm**

Code	Description
4200005011	5011-THE. SPANNERS FROM 6x7 TO 20x22

**Contenuto:**

CODICE	DESCRIZIONE
4200060607	6-6x7-Chiave fissa
4200060809	6-8x9- Chiave fissa
4200061011	6-10x11- Chiave fissa
4200061213	6-12x13- Chiave fissa
4200061415	6-14x15- Chiave fissa
4200061617	6-16x17- Chiave fissa
4200061819	6-18x19- Chiave fissa
4200062022	6-20x22-Chiave fissa
3980005011	termo vuoto

### Thermo spanners from 21x23 to 30x32 -4 pcs



- Made of Plastazote, a soft material resistant to fats and oils. P { margin-bottom: 0.21cm; }
- 1/2 format of the drawer
- **Size 265x370 mm**

Code	Description
4200005021	5021-TERMO CH.FISSE 21X23-30X32

**Contenuto:**

CODICE	DESCRIZIONE
4200062123	6-21x23 - chiave fissa
4200062426	6-24x26 - chiave fissa
4200062528	6-25x28 - chiave fissa
4200063032	6-30x32 - chiave fissa
3980005021	Termo vuoto



### Combination thermo wrenches from 6 to 22 - 17 pcs



- Made of Plastazote, a soft material resistant to fats and oils.

Code	Description
4200005023	5023-THE.COMBIN.WREN. FROM SIZE 6 TO 22

**Contenuto:**

CODICE	DESCRIZIONE
4200011006	11-6 Chiave combinata
4200011007	11-7 Chiave combinata
4200011008	11-8 Chiave combinata
4200011009	11-9 Chiave combinata
4200011010	11-10 Chiave combinata
4200011011	11-11 Chiave combinata
4200011012	11-12 Chiave combinata
4200011013	11-13 Chiave combinata
4200011014	11-14 Chiave combinata
4200011015	11-15 Chiave combinata
4200011016	11-16 Chiave combinata
4200011017	11-17 Chiave combinata
4200011018	11-18 Chiave combinata
4200011019	11-19 Chiave combinata
4200011020	11-20 Chiave combinata
4200011021	11-21 Chiave combinata
4200011022	11-22 Chiave combinata
3980005023	Termo vuoto



## Combination thermo wrenches from 23 to 32 - 8 Pcs



- Made of Plastazote, a soft material resistant to fats and oils.
- 3/3 format of the drawer
- **Size 530 x370 mm**

Code	Description
4200005022	5022-TH.COMB.WREN. FROM SIZE 23 TO 32

**Contenuto:**

CODICE	DESCRIZIONE
4200011023	11-23 Chiave combinata
4200011024	11-24 Chiave combinata
4200011025	11-25 Chiave combinata
4200011026	11-26 Chiave combinata
4200011027	11-27 Chiave combinata
4200011028	11-28 Chiave combinata
4200011030	11-30 Chiave combinata
4200011032	11-32 Chiave combinata
3980005022	Termo vuoto

## Combination ratchet thermo wrenches from 8 to 19 - 8 pcs

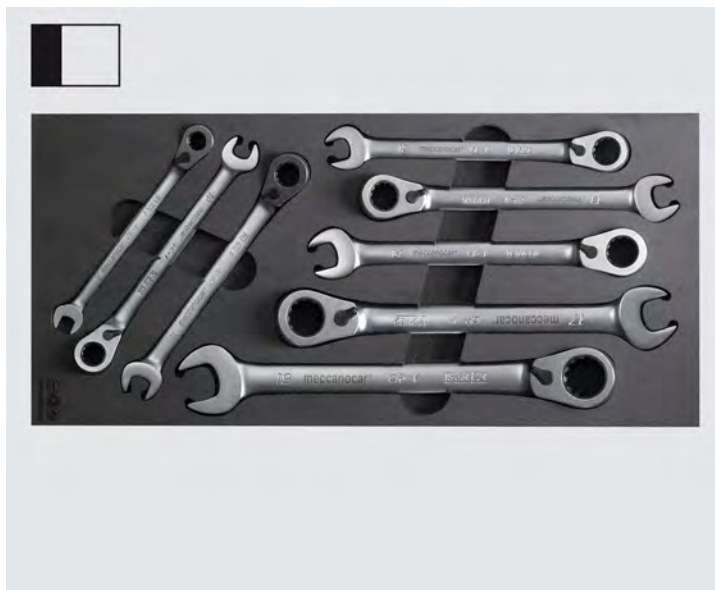

- Made of Plastazote, a soft material resistant to fats and oils. P { margin-bottom: 0.21cm; }
- 1/3 format of the drawer
- **Size 176x370 mm**

Code	Description
4200005012	5012-THE.COMBIN.RAT.WREN.FROM SIZE 8 TO 19

**Contenuto:**

CODICE	DESCRIZIONE
4200000390	8-Chiave a cricchetto
4200000392	10-Chiave a cricchetto
4200000394	11-Chiave a cricchetto
4200000396	12-Chiave a cricchetto
4200000398	13-Chiave a cricchetto
4200000400	14-Chiave a cricchetto
4200000406	17-Chiave a cricchetto
4200000408	19-Chiave a cricchetto
3980005012	termo vuoto

## Thermo hex/polygon L-shaped wrenches- 11 Pcs.



- Made of Plastazote, a soft material resistant to fats and oils.
- 1/2 format of the drawer
- **Size 265x370 mm**

Code	Description
4200005034	5034-THERMO HEX/POL.L-SHAPED WRENCH FROM 6 TO 22

**Contenuto:**

CODICE	DESCRIZIONE
4200027206	6 ch. a pipa esag / esag.
4200027207	7 ch. a pipa esag / esag.
4200027208	8 ch. a pipa esagono/polig.
4200027210	10 ch. a pipa esagono/polig.
4200027211	11 ch. a pipa esagono/polig.
4200027212	12 ch. a pipa esagono/polig.
4200027213	13 ch. a pipa esagono/polig.
4200027214	14 ch. a pipa esagono/polig.
4200027217	17 ch. a pipa esagono/polig.
4200027219	19 ch. a pipa esagono/polig.
4200027222	22 ch. a pipa esagono/polig.
3980005034	Termo vuoto

## Thermo slotted screwdrivers 6 Pcs.

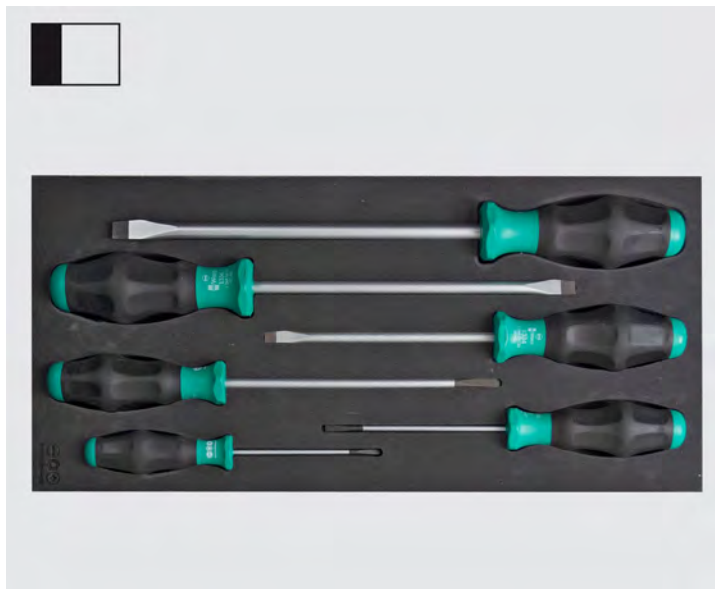

- Made of Plastazote, a soft material resistant to fats and oils.
- 1/3 format of the drawer
- **Size 176x370 mm**

Code	Description
4200005006	5006-THERMO SLOTTED SCREWDRIVERS

**Contenuto:**

CODICE	DESCRIZIONE
4200100210	3X80 Cacciavite a taglio
4200100215	4X100 Cacciavite a taglio
4200100220	5,5X150 Cacciavite a taglio
4200100225	6X125 Cacciavite a taglio
4200100230	8X175 Cacciavite a taglio
4200100235	10X200 Cacciavite a taglio
3980005006	Termo vuoto

## PH Thermo Phillips screwdrivers - 6 Pcs.

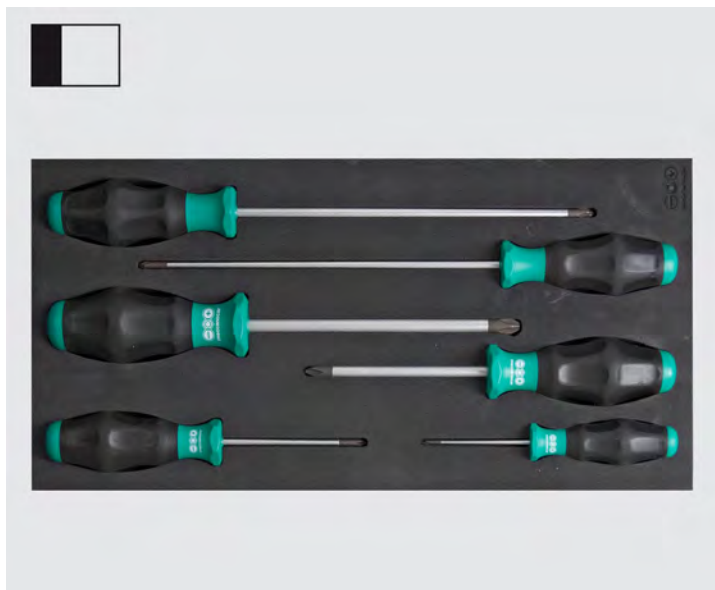

- 1/3 format of the drawer
- Size 176x370 mm

Code	Description
4200005007	5006-THERMO SLOTTED SCREWDRIVERS

**Contenuto:**

CODICE	DESCRIZIONE
4200100255	PH0 Cacciavite a croce
4200100260	PH1 Cacciavite a croce
4200100265	PH1X200 Cacciavite a croce
4200100270	PH2 Cacciavite a croce
4200100275	PH2X200 Cacciavite a croce
4200100280	PH3 Cacciavite a croce
3980005007	Termo vuoto



## Torx thermo screwdrivers- 8 Pcs

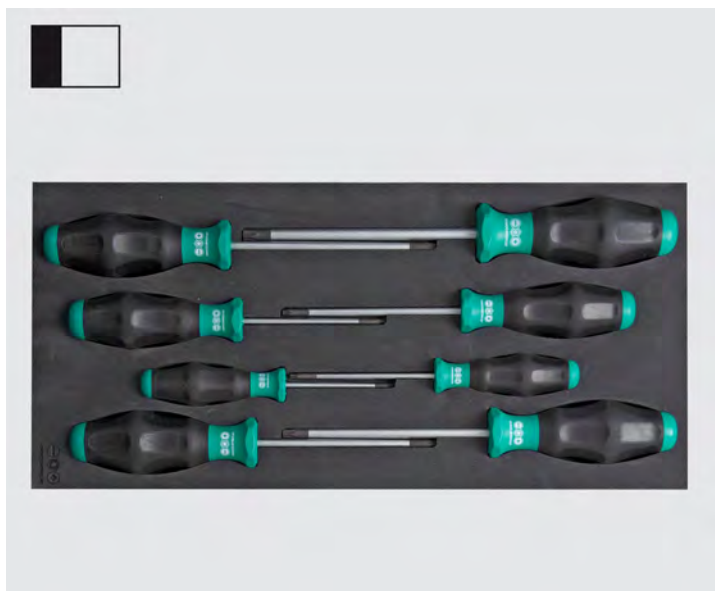

- Made of Plastazote, a soft material resistant to fats and oils
- 1/3 format of the drawer
- **Size 176x370 mm**

Code	Description
4200005008	5008-TORX THERMO SCREWDRIVERS

**Contenuto:**

CODICE	DESCRIZIONE
4200100300	TX8 Cacciavite torx
4200100305	TX10 Cacciavite torx
4200100310	TX15 Cacciavite torx
4200100315	TX20 Cacciavite torx
4200100320	TX25 Cacciavite torx
4200100325	TX27 Cacciavite torx
4200100330	TX30 Cacciavite torx
4200100335	TX40 Cacciavite torx
3980005008	Termo vuoto



## Thermo 3 pliers

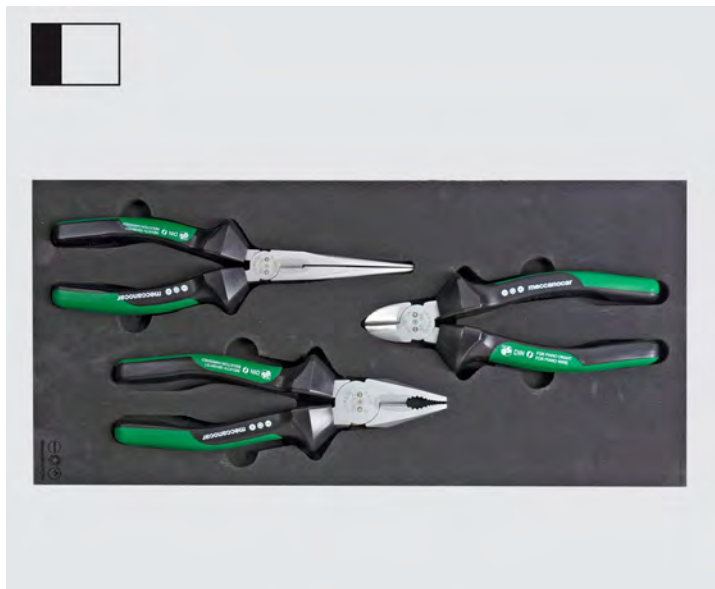

- Made of Plastazote, a soft material resistant to fats and oil
- 1/3 format of the drawer
- **Size 176x370 mm**

Code	Description
4200005001	5001-THERMO 3 PLIERS

**Contenuto:**

CODICE	DESCRIZIONE
4200041180	Pinza universale 180mm
4200015200	Pinza becchi 1/2 t.diritti
4200029160	Tronchese t.diagonale
3980005001	Termo vuoto

## Thermo Pliers + Pincers 3 Pcs.



- Made of Plastazote, a soft material resistant to fats and oils. P { margin-bottom: 0.21cm; }
- 1/3 format of the drawer
- **Size 176x370 mm**

Code	Description
4200005005	5005-THERMO PLIERS+PINCERS

**Contenuto:**

CODICE	DESCRIZIONE
4200093250	Tenaglia 250mm
4200077240	Pinza poligrif 240mm
4200017200	Pinza becchi 1/2 t.piegati
3980005005	Termo vuoto

## Thermo Seeger pliers for external+internal rings - 4 Pcs.

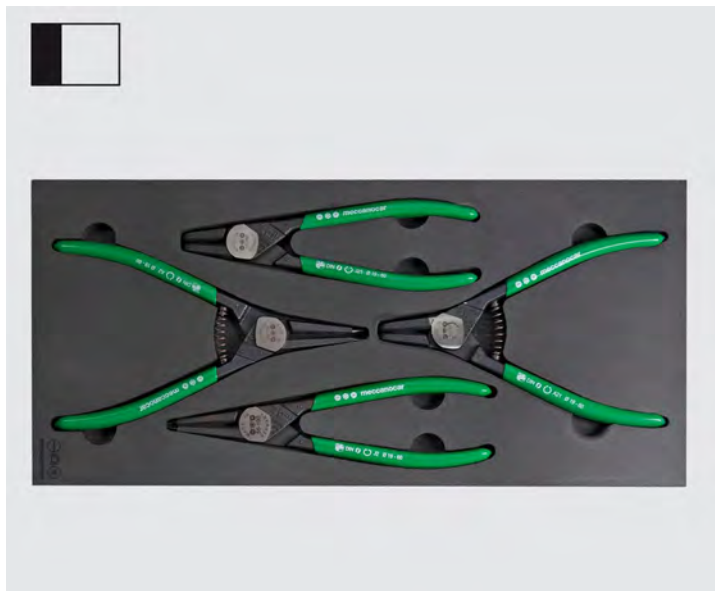

- Made of Plastazote, a soft material resistant to fats and oils.
- 1/3 format of the drawer
- **Size 176x370 mm**

Code	Description
4200005003	5003-TH.SEEGER PLIERS FOR EXT.INT.RINGS

**Contenuto:**

CODICE	DESCRIZIONE
4200054190	Pinza seeger
4200055190	Pinza seeger
4200056190	Pinza seeger
4200057190	Pinza seeger
3980005003	termo vuoto

## Thermo 1/4" socket accessories - 7 Pcs.

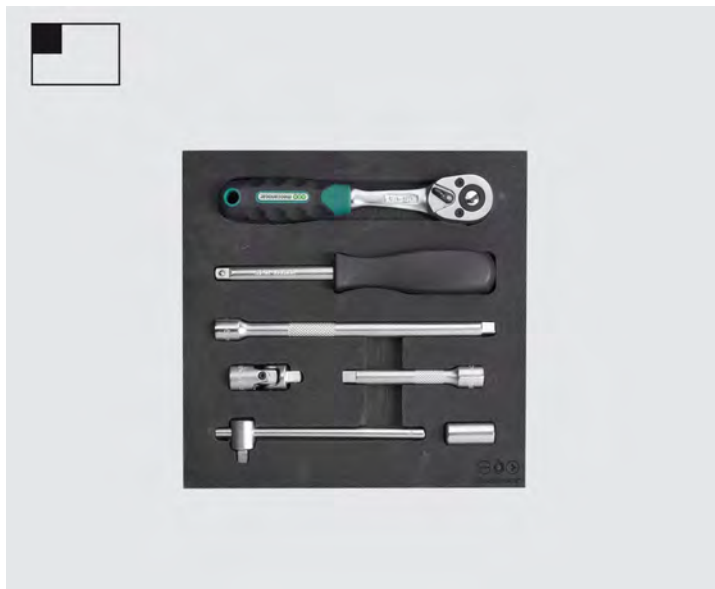

- Made of Plastazote, a soft material resistant to fats and oils
- 1/6 format of the drawer
- **Size 176x185**

Code	Description
4200005029	5029-TH.1/4" SOCKET ACC.

**Contenuto:**

CODICE	DESCRIZIONE
420000105	¼ cricco
420000160	75 mm prolunga
420000162	150 mm prolunga
420000168	1/4-1/4 es adattatore
420000164	Snodo cardanico
420000170	Asta con attacco scorrevole ¼
420000166	Porta bussola manicato
3980005029	Termo vuoto

## Termo bussole esagonali corte e lunghe da 1/4" - 22 Pz.



- Made of Plastazote, a soft material resistant to fats and oils
- 1/6 format of the drawer
- **Size 176x185**

Code	Description
4200005032	5032-TH. HEX.SOCKET 1/4"SHORT LONG

**Contenuto:**

CODICE	DESCRIZIONE	CODICE	DESCRIZIONE
420000110	4C Bussola esag.corta ¼	420000134	14 Bussola esag.corta ¼
420000112	4.5 Bussola esag.corta ¼	420000140	6L Bussola esag.lunga ¼
420000114	5 Bussola esag.corta ¼	420000142	7 Bussola esag.lunga ¼
420000116	5.5 Bussola esag.corta ¼	420000144	8 Bussola esag.lunga ¼
420000118	6 Bussola esag.corta ¼	420000146	9 Bussola esag.lunga ¼
420000120	7 Bussola esag.corta ¼	420000148	10 Bussola esag.lunga ¼
420000122	8 Bussola esag.corta ¼	420000150	11 Bussola esag.lunga ¼
420000124	9 Bussola esag.corta ¼	420000152	12 Bussola esag.lunga ¼
420000126	10 Bussola esag.corta ¼	420000154	13 Bussola esag.lunga ¼
420000128	11 Bussola esag.corta ¼	420000156	14 Bussola esag.lunga ¼
420000130	12 Bussola esag.corta ¼	3980005032	Termo vuoto
420000132	13 Bussola esag.corta ¼		

## Thermo short and long hex sockets 1/4" - 53 Pcs.

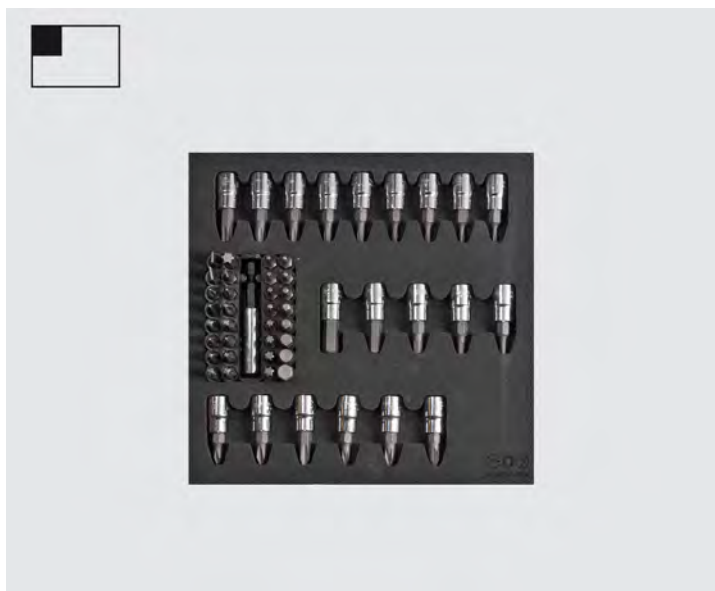

- Made of Plastazote, a soft material resistant to fats and oils
- 1/6 format of the drawer
- **Size 176x185**

Code	Description
4200005030	5030-THE.1/4" SHO.SOCK.VARIOUS PROF.

**Contenuto:**

CODICE	DESCRIZIONE	CODICE	DESCRIZIONE
4200098841	PH1 bussola ¼	4200098870	tx8 bussola ¼
4200098842	PH2 bussola ¼	4200098872	tx9 bussola ¼
4200098843	PH3 bussola ¼	4200098874	tx10 bussola ¼
4200098851	PZ1 bussola ¼	4200098876	tx15 bussola ¼
4200098852	PZ2 bussola ¼	4200098878	tx20 bussola ¼
4200098853	PZ3 bussola ¼	4200098880	tx25 bussola ¼
4200098853	3 ES bussola ¼	4200098882	tx27 bussola ¼
4200098854	4 ES bussola ¼	4200098884	tx30 bussola ¼
4200098855	5 ES bussola ¼	4200098886	tx40 bussola ¼
4200098856	6 ES bussola ¼	4200000167	Serie bits ¼ + porta bits
4200098858	8 ES bussola ¼	3980005030	Termo vuoto



## Termo bits corti e lunghi da 3/8"+2 bussole porta bits - 40 Pz.



- Realizzati in Plastazote, materiale morbido resistente a grassi e oli.
- Idonei per cassette L.min. 530mm e H.min. 370mm
- **Formato 1/3 del cassetto - Misura 176x370mm**

Code	Description
4200005013	5013-TER.BITS3/8+2 BUS.POR.BITS

**Contenuto:**

CODICE	DESCRIZIONE	CODICE	DESCRIZIONE
4430042510	4-130 esagonale	4430042575	5-175 esagonale
4430042520	5-130 esagonale	4430042580	6-175 esagonale
4430042530	6-130 esagonale	4430042572	7-175 esagonale
4430042540	7-130 esagonale	4430042585	8-175 esagonale
4430042550	8-130 esagonale	4430042590	10-175 esagonale
4430042560	10-130 esagonale	4430042592	12-175 esagonale
4430042570	12-130 esagonale	4430044310	Tx20
4430044400	Tx20 I30 torx	4430044312	Tx25
4430044401	Tx25 I30 torx	4430044316	Tx30
4430044402	Tx30 I30 torx	4430044318	Tx40
4430044403	Tx40 I30 torx	4430044320	Tx45
4430044404	Tx45 I30 torx	4430044322	Tx50
4430044405	Tx50 I30 torx	4430044324	Tx55
4430044406	Tx55 I30 torx	4430044528	5 xzn I75
4430044480	5 xzn I30	4430044530	6 xzn I75
4430044490	6 xzn I30	4430044540	8 xzn I75
4430044500	8 xzn I30	4430044550	10 xzn I75
4430044510	10 xzn I30	4430044560	12 xzn I75
4430044520	12 xzn I30	4430044570	3/8-1/2 bussola porta bits
4430042574	4-175 esagonale	4430047506	3/8-3/8 bussola porta bits
		3980005013	Termo vuoto

## Termo accessori per bussole 1/2" - 6 Pz.

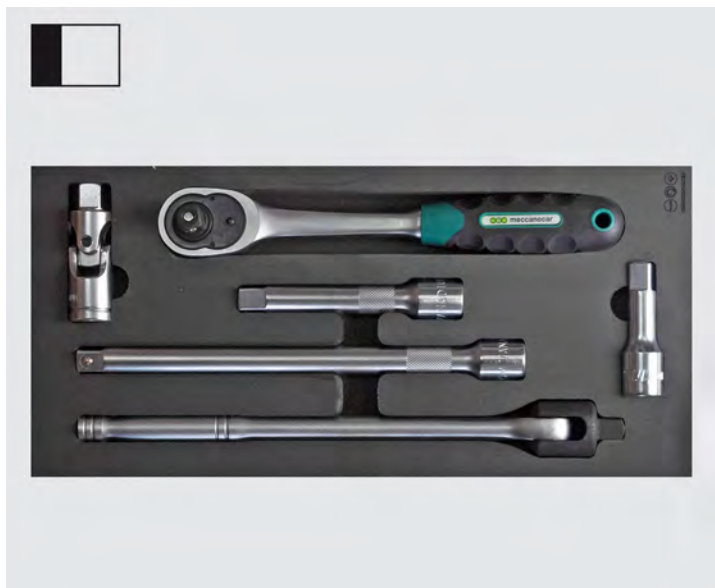

- Realizzato in Plastazote, materiale morbido resistente a grassi e oli.
- Idonei per cassette L.min. 530mm e H.min. 370mm
- **Formato 1/3 del cassetto - Misura 176x370mm**

Code	Description
4200005016	5016-TERMO ACCES.X BUS.DA1/2"

**Contenuto:**

CODICE	DESCRIZIONE
4200000305	Cricco 1/2
4200000379	Prolunga 1/2 I 75
4200000380	Prolunga 1/2 I 125
4200000382	Prolunga 1/2 I 250
4200000384	Snodo cardanico 1/2
4200000385	Impugnatura con snodo 1/2
4200000518	Asta con attacco scorr. 1/2
3980005016	Termo vuoto

## Termo bussole esagonali corte 1/2" - 18 Pz.



- Realizzato in Plastazote, materiale morbido resistente a grassi e oli.
- Idonei per cassette L.min. 530mm e H.min. 370mm
- **Formato 1/6 del cassetto - Misura 176x185mm**

Code	Description
4200005035	5035-TERMO BUS.ESA.1/2"CORTE

**Contenuto:**

CODICE	DESCRIZIONE	CODICE	DESCRIZIONE
4200000360	10 Bussola esag.corta 1/2	4200000370	20 Bussola esag.corta 1/2
4200000361	11 Bussola esag.corta 1/2	4200000371	21 Bussola esag.corta 1/2
4200000362	12 Bussola esag.corta 1/2	4200000372	22 Bussola esag.corta 1/2
4200000363	13 Bussola esag.corta 1/2	4200000373	23 Bussola esag.corta 1/2
4200000364	14 Bussola esag.corta 1/2	4200000374	24 Bussola esag.corta 1/2
4200000365	15 Bussola esag.corta 1/2	4200000375	27 Bussola esag.corta 1/2
4200000366	16 Bussola esag.corta 1/2	4200000376	30 Bussola esag.corta 1/2
4200000367	17 Bussola esag.corta 1/2	4200000377	32 Bussola esag.corta 1/2
4200000368	18 Bussola esag.corta 1/2	3980005035	Termo vuoto
4200000369	19 Bussola esag.corta 1/2		



## Termo bussole esagonali lunghe 1/2" - 19 Pz.

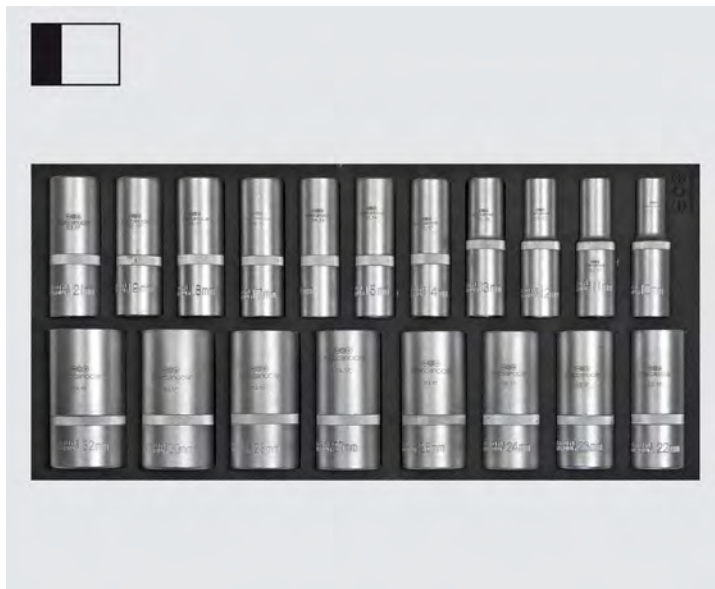

- Realizzato in Plastazote, materiale morbido resistente a grassi e oli.
- Idonei per cassette L.min. 530mm e H.min. 370mm
- **Formato 1/3 del cassetto - Misura 176x370mm**

Code	Description
4200005017	5017-TERMO BUS.ESA.1/2"LUNGHE

**Contenuto:**

CODICE	DESCRIZIONE	CODICE	DESCRIZIONE
4200098960	10 bussola esag.lunga 1/2	4200098971	21 bussola esag.lunga 1/2
4200098961	11 bussola esag.lunga 1/2	4200098972	22 bussola esag.lunga 1/2
4200098962	12 bussola esag.lunga 1/2	4200098973	23 bussola esag.lunga 1/2
4200098963	13 bussola esag.lunga 1/2	4200098974	24 bussola esag.lunga 1/2
4200098964	14 bussola esag.lunga 1/2	4200098976	26 bussola esag.lunga 1/2
4200098965	15 bussola esag.lunga 1/2	4200098977	27 bussola esag.lunga 1/2
4200098966	16 bussola esag.lunga 1/2	4200098978	28 bussola esag.lunga 1/2
4200098967	17 bussola esag.lunga 1/2	4200098980	30 bussola esag.lunga 1/2
4200098968	18 bussola esag.lunga 1/2	4200098982	32 bussola esag.lunga 1/2
4200098969	19 bussola esag.lunga 1/2	3980005017	Termo vuoto.

## Termo bussole poligonali corte 1/2" - 22 Pz.



- Realizzato in Plastazote, materiale morbido resistente a grassi e oli.
- Idonei per cassette L.min. 530mm e H.min. 370mm
- **Formato 1/3 del cassetto - Misura 176x370mm**

Code	Description
4200005019	5019-TERMO BUS.POL.1/2"CORTE

**Contenuto:**

CODICE	DESCRIZIONE	CODICE	DESCRIZIONE
4200098990	10 bussola polig.corta 1/2	4200099022	22 bussola polig.corta 1/2
4200098991	11 bussola polig.corta 1/2	4200099023	23 bussola polig.corta 1/2
4200098992	12 bussola polig.corta 1/2	4200099024	24 bussola polig.corta 1/2
4200098993	13 bussola polig.corta 1/2	4200099025	25 bussola polig.corta 1/2
4200098994	14 bussola polig.corta 1/2	4200099028	26 bussola polig.corta 1/2
4200098995	15 bussola polig.corta 1/2	4200099027	27 bussola polig.corta 1/2
4200098996	16 bussola polig.corta 1/2	4200099028	28 bussola polig.corta 1/2
4200098997	17 bussola polig.corta 1/2	4200099029	29 bussola polig.corta 1/2
4200098998	18 bussola polig.corta 1/2	4200099030	30 bussola polig.corta 1/2
4200098999	19 bussola polig.corta 1/2	4200099032	32 bussola polig.corta 1/2
4200099000	20 bussola polig.corta 1/2	3980005019	termo vuoto.
4200099021	21 bussola polig.corta 1/2		

## Termo bussole poligonali lunghe 1/2" - 19 Pz.



- Realizzato in Plastazote, materiale morbido resistente a grassi e oli.
- Idonei per cassette L.min. 530mm e H.min. 370mm
- **Formato 1/3 del cassetto - Misura 176x370mm**

Code	Description
4200005018	5018-TERMO BUS.POL.1/2"LUNGHE

**Contenuto:**

CODICE	DESCRIZIONE	CODICE	DESCRIZIONE
4200099040	10 bussola polig.lunga 1/2	4200099051	21 bussola polig.lunga 1/2
4200099041	11 bussola polig.lunga 1/2	4200099052	22 bussola polig.lunga 1/2
4200099042	12 bussola polig.lunga 1/2	4200099053	23 bussola polig.lunga 1/2
4200099043	13 bussola polig.lunga 1/2	4200099054	24 bussola polig.lunga 1/2
4200099044	14 bussola polig.lunga 1/2	4200099056	26 bussola polig.lunga 1/2
4200099045	15 bussola polig.lunga 1/2	4200099057	27 bussola polig.lunga 1/2
4200099046	16 bussola polig.lunga 1/2	4200099058	28 bussola polig.lunga 1/2
4200099047	17 bussola polig.lunga 1/2	4200099060	30 bussola polig.lunga 1/2
4200099048	18 bussola polig.lunga 1/2	4200099062	32 bussola polig.lunga 1/2
4200099049	19 bussola polig.lunga 1/2	3980005018	termo vuoto.



## Termo bussole esagonali maschio corte e lunghe 1/2" - 16 Pz.



- Realizzato in Plastazote, materiale morbido resistente a grassi e oli.
- Ideali per cassette L.min. 530mm e H.min. 370mm
- **Formato 1/3 del cassetto - Misura 176x370mm**

Code	Description
4200005015	5015-TERMO BUS.ESA.1/2"COR.LUN.

**Contenuto:**

CODICE	DESCRIZIONE	CODICE	DESCRIZIONE
420000312	Bussola es.m.corta 1/2	420000323	Bussola es.m.lunga 1/2
420000313	Bussola es.m.corta 1/2	420000324	Bussola es.m.lunga 1/2
420000314	Bussola es.m.corta 1/2	420000325	Bussola es.m.lunga 1/2
420000315	Bussola es.m.corta 1/2	420000326	Bussola es.m.lunga 1/2
420000316	Bussola es.m.corta 1/2	420000327	Bussola es.m.lunga 1/2
420000317	Bussola es.m.corta 1/2	420000328	Bussola es.m.lunga 1/2
420000318	Bussola es.m.corta 1/2	3980005015	Termo vuoto
420000319	Bussola es.m.corta 1/2		
420000320	Bussola es.m.corta 1/2		
420000321	Bussola es.m.corta 1/2		

## Termo bussole Torx maschio lunghe 1/2" - 10 Pz.



- Realizzato in Plastazote, materiale morbido resistente a grassi e oli.
- Ideali per cassette L.min. 530mm e H.min. 370mm
- **Formato 1/3 del cassetto - Misura 176x370mm**

Code	Description
4200005014	5014-TERMO BUS.TORX.1/2"LUN.

**Contenuto:**

CODICE	DESCRIZIONE
420000343	Bussola tx m.lunga 1/2
420000344	Bussola tx m.lunga 1/2
420000345	Bussola tx m.lunga 1/2
420000346	Bussola tx m.lunga 1/2
420000347	Bussola tx m.lunga 1/2
420000348	Bussola tx m.lunga 1/2
420000349	Bussola tx m.lunga 1/2
420000350	Bussola tx m.lunga 1/2
420000351	Bussola tx m.lunga 1/2
420000352	Bussola tx m.lunga 1/2
3980005014	Termo vuoto

## Termo bussole Torx maschio corte 1/2" - 10 Pz.



- Realizzato in Plastazote, materiale morbido resistente a grassi e oli.
- Ideali per cassette L.min. 530mm e H.min. 370mm
- **Formato 1/6 del cassetto - Misura 176x185mm**

Code	Description
4200005025	5025-TERMO BUS.TORX.1/2"COR.

**Contenuto:**

CODICE	DESCRIZIONE
420000332	T15 bussola torx corta 1/2
420000333	T20 bussola torx corta 1/2
420000334	T25 bussola torx corta 1/2
420000335	T27 bussola torx corta 1/2
420000336	T30 bussola torx corta 1/2
420000337	T40 bussola torx corta 1/2
420000338	T45 bussola torx corta 1/2
420000339	T50 bussola torx corta 1/2
420000340	T55 bussola torx corta 1/2
420000341	T60 bussola torx corta 1/2
3980005025	Termo vuoto



## Termo bussole XZN corte e lunghe 1/2" - 10 Pz.



- Realizzato in Plastazote, materiale morbido resistente a grassi e oli.
- Ideali per cassette L.min. 530mm e H.min. 370mm
- **Formato 1/6 del cassetto - Misura 176x185mm**

Code	Description
4200005026	5026-TERMO BUS.XZN.1/2"COR.LUN.

### Contenuto:

CODICE	DESCRIZIONE
4200099075	M5C bussola XZN 1/2"
4200099076	M6C bussola XZN 1/2"
4200099078	M8C bussola XZN 1/2"
4200099080	M10C bussola XZN 1/2"
4200099082	M12C bussola XZN 1/2"
4200099084	M14C bussola XZN 1/2"
4200099096	M8L bussola XZN 1/2"
4200099098	M8L bussola XZN 1/2"
4200099100	M10L bussola XZN 1/2"
4200099102	M102L bussola XZN 1/2"
3980005026	Termo vuoto

## Termo bussole Ribe lunghe 1/2" - 7 Pz.



- Realizzato in Plastazote, materiale morbido resistente a grassi e oli.
- Ideali per cassette L.min. 530mm e H.min. 370mm
- **Formato 1/6 del cassetto - Misura 176x185mm**

Code	Description
4200005024	5024-TERMO BUS.RIBE 1/2 LUN.

### Contenuto:

CODICE	DESCRIZIONE
4200099105	M5 bussola ribe lunga 1/2"
4200099106	M6 bussola ribe lunga 1/2"
4200099107	M7 bussola ribe lunga 1/2"
4200099108	M8 bussola ribe lunga 1/2"
4200099109	M9 bussola ribe lunga 1/2"
4200099110	M10 bussola ribe lunga 1/2"
4200099112	M12 bussola ribe lunga 1/2"
3980005024	Termo vuoto

## Termo accessori e bussole esag.corte 3/4" - 17 Pz.



- Realizzato in Plastazote, materiale morbido resistente a grassi e oli.
- Ideali per cassette L.min. 530mm e H.min. 370mm
- **Formato 3/3 del cassetto - Misura 530x370mm**

Code	Description
4200005031	5031-TERMO ACCES.+BUS.DA3/4"

### Contenuto:

CODICE	DESCRIZIONE	CODICE	DESCRIZIONE
4200099300	Cricco reversibile 3/4"	4200099133	33 bussola esag corta 3/4"
4200099320	Asta con attacco scorrevole	4200099136	36 bussola esag corta 3/4"
4200099304	Prolunga l 100 mm	4200099138	38 bussola esag corta 3/4"
4200099308	Prolunga l 200 mm	4200099141	41 bussola esag corta 3/4"
4200099122	22 bussola esag corta 3/4"	4200099146	46 bussola esag corta 3/4"
4200099124	24 bussola esag corta 3/4"	4200099150	50 bussola esag corta 3/4"
4200099127	27 bussola esag corta 3/4"	4200099155	55 bussola esag corta 3/4"
4200099130	30 bussola esag corta 3/4"	4200099160	60 bussola esag corta 3/4"
4200099132	32 bussola esag corta 3/4"	3980005031	Termo vuoto

## Termo martelli e scalpello - 3 Pz.

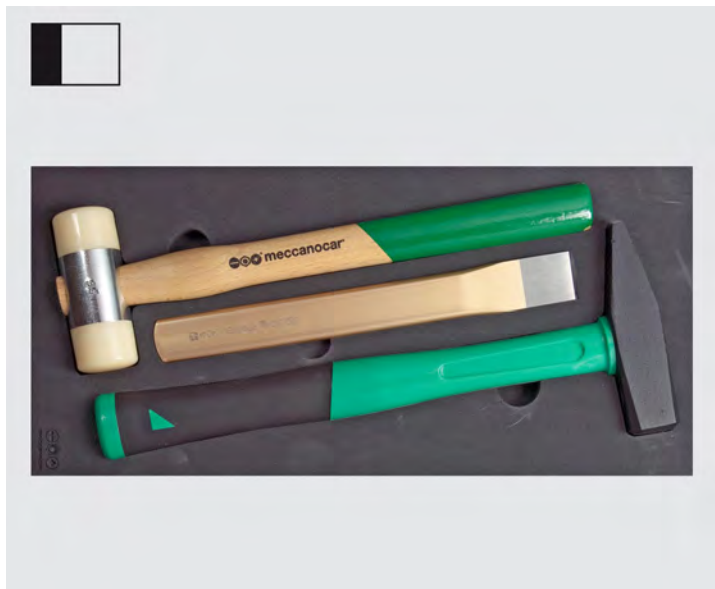

- Realizzato in Plastazote, materiale morbido resistente a grassi e oli.
- Ideali per cassette L.min. 530mm e H.min. 370mm
- **Formato 1/3 del cassetto - Misura 176x370mm**

Code	Description
4200005004	5004-TERMO MARTELLI+SCALPELLO

**Contenuto:**

CODICE	DESCRIZIONE
4430045640	Martello
4430056320	Scalpello piatto
4430013400	Mazzuola
3980005004	Termo vuoto

## Termo lime e impugnatura per lame seghetto - 4 Pz.



- Realizzato in Plastazote, materiale morbido resistente a grassi e oli.
- Ideali per cassette L.min. 530mm e H.min. 370mm
- **Formato 1/3 del cassetto - Misura 176x370mm**

Code	Description
4200005009	5009-TERMO LIME + IMP.LAME SEGHETTO

**Contenuto:**

CODICE	DESCRIZIONE
4430045930	3 x lime
4430055755	Impugnatura lame seghetto
3980005009	Termo vuoto

## Termo utensili vari - 6 Pz.

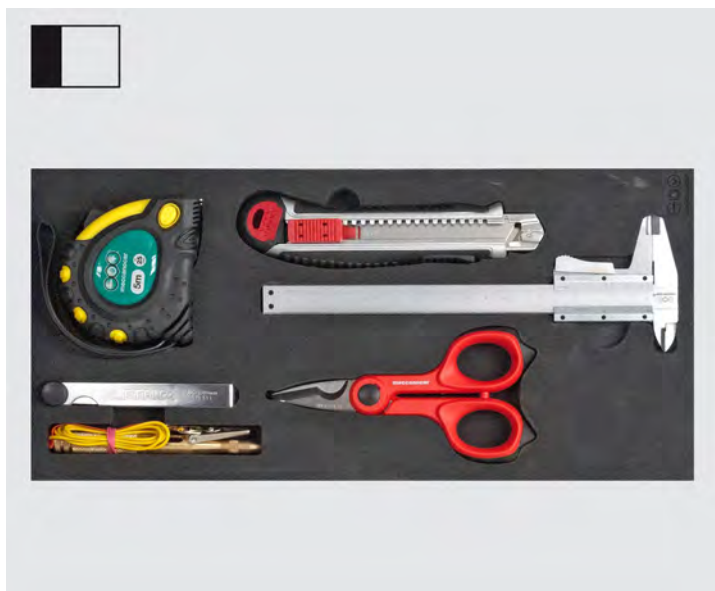

- Realizzato in Plastazote, materiale morbido resistente a grassi e oli.
- Ideali per cassette L.min. 530mm e H.min. 370mm
- **Formato 1/3 del cassetto - Misura 176x370mm**

Code	Description
4200005010	5010-TERMO UTENSILI VARI

**Contenuto:**

CODICE	DESCRIZIONE
4430050755	Fiessometro 5 m
4880081610	12905 prova circuiti
4430049265	Stumenti Misura
4430002611	Forbice elettricista
4430027220	338/20 spessimetro
4430027000	Calibro
3980005010	Termo vuoto

## Termo cacciaspine - 6 Pz.

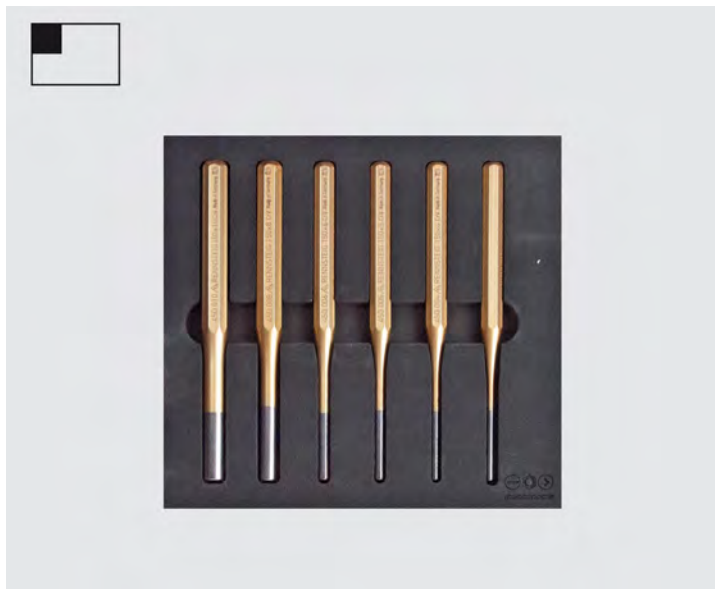

- Realizzato in Plastazote, materiale morbido resistente a grassi e oli.
- Ideali per cassette L.min. 530mm e H.min. 370mm
- **Formato 1/6 del cassetto - Misura 176x185mm**

Code	Description
4200005028	5028-TERMO CACCIASPINE

### Contenuto:

CODICE	DESCRIZIONE
4430056360	150x3 cacciaspine
4430056365	150x4 cacciaspine
4430056370	150x5 cacciaspine
4430056375	150x6 cacciaspine
4430056380	150x8 cacciaspine
4430056385	150x10 cacciaspine
3980005028	Termo vuoto

## Termo scalpelli punteruoli e punzoni - 6 Pz.

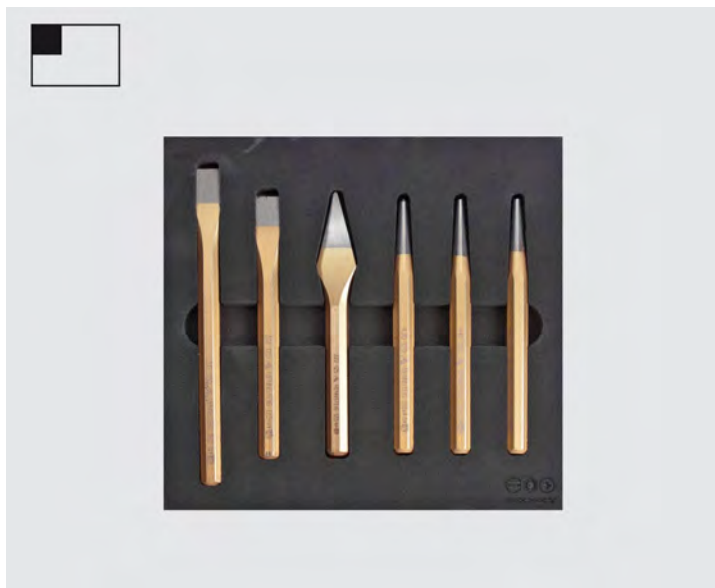

- Realizzato in Plastazote, materiale morbido resistente a grassi e oli.
- Ideali per cassette L.min. 530mm e H.min. 370mm
- **Formato 1/6 del cassetto - Misura 176x185mm**

Code	Description
4200005027	5027-TERMO PUNT.PUNZONI

### Contenuto:

CODICE	DESCRIZIONE
4430056300	1750-10x125 scalpello piatto
4430056305	1750-10x150 scalpello piatto
4430056310	1751-10x125 scalpello a punta
4430056355	1755-120x4 punteruolo
4430056345	1756 -120x3 punzone
4430056346	1756-120x4 punzone
3980005027	Termo vuoto

## Termo estrattori - 13 Pz.



- Realizzato in Plastazote, materiale morbido resistente a grassi e oli.
- Ideali per cassette L.min. 530mm e H.min. 370mm
- **Formato 1/6 del cassetto - Misura 176x185mm**

Code	Description
4200005033	5033-TERMO ESTRATTORI

### Contenuto:

CODICE	DESCRIZIONE
4430024800	Serie estrattori sx-3-24
4430025020	316T-760 sollevatore a tasc.
4430040851	6 estratt. prigionieri
4430040852	7 estratt. prigionieri
4430040853	8 estratt. prigionieri
4430040855	10 estratt. prigionieri
4430040857	12 estratt. prigionieri
4430040858	14 estratt. prigionieri
3980005033	Termo vuoto



### Striscia di finitura carrello 6 cassette n/s art. 4700010500



- Striscia rettangolare per finitura cassetto su carrelli a 6 cassette
- Stesso materiale dei termoformati
- Per n/s carrelli a 6 cassette art. 4700010500

Code	Description
3980005036	5036-35x370mm

### Striscia di finitura carrello 7 e 8 cassette n/s art. 4700010300-10400



- Striscia rettangolare per finitura cassetto su carrelli a 7 e 8 cassette
- Stesso materiale dei termoformati
- Per n/s carrelli a 7 e 8 cassette art. 4700010300-10400

Code	Description
3980005037	5037-37x532mm



## Rapid clamps



- Rapid clamp.
- Handle with rubber, non-slip and ergonomic.
- Bar steel which allows maximum pressures and reduces the danger of buckle and twist.
- New locking system that increases the capacity clamping and sealing of 40%.

Code	Desc.	Opening mm
4430012595	224P - 300	300
4430012598	224P - 605	605

## Clamps for carpenters and shipyards



- Steel clamps with sliding plug.

Code	Desc.	Opening mm
4430012620	224 - 250	250
4430012630	224 - 300	300
4430012640	224 - 350	350
4430012650	224 - 400	400
4430012670	224 - 500	500
4430012680	224 - 600	600
4430012690	224 - 800	800
4430012700	224 - 1000	1000



## Clamps Steel Professional



- Clamps entirely forged steel, galvanized protection extremely durable, one-piece construction.
- Screw steel running rolled and burnished, special hood drawn and machined for precision fastening.
- Extremely robust construction to ensure safe usage for all types of heavy machining.
- Lower screw for locking the movable arm to the simple plucking and its use also as retractors, through the application of appropriate heads supplied separately. ideal for use by carpenters, locksmiths, mechanics, fitters, mechanics, etc..



TESTINE PER L'UTILIZZO  
COME DIVARICATORI

Code	Desc.	Opening mm	Depth mm	Sez.Guida mm	Weight Kg.
4430050540	1010/16	160	80	16X7.5	0.5
4430050545	1010/20	200	100	19.5X9.5	0.9
4430050550	1010/30	300	140	25X12	1.8
4430050555	1010/40	400	120	25X12	1.9
4430050560	1010/50	500	120	25X12	2.1
4430050565	1010/60	600	120	25X12	2.3
4430050570	1010/80	800	120	27X13	3.3
4430050575	1010/100	1.000	120	27X13	3.70

8

Spare Parts		
Code	Desc.	Heads for use as retractors for Clamps
4430050650	1012G	Length 300 to 1,000

## Clamps steel rapid professional



- Clamps entirely forged steel, galvanized protection extremely durable, one-piece construction.
- Clamping system with the ratchet lever, which makes application very fast and safe in every type of use.
- Fine teeth for better regulation of tightening, hood pressure moving platen. Anatomic handle in one piece.
- Extremely robust construction to ensure safe usage for all types of heavy machining.
- Lower screw for locking the movable arm to the simple plucking and its use also as retractors.

Code	Desc.	Opening mm	Depth mm	Sez.Guida mm	Weight Kg.
4430050600	1011/16	160	80	16X8	1.0
4430050605	1011/20	200	100	20X10	1.3
4430050610	1011/25	250	120	22X11	1.9
4430050615	1011/30	300	140	25X12	2.7

## Universal extractors with 2 arms

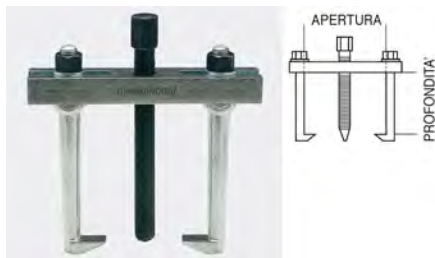

- Puller Tool universal 2-arm for interior and exterior steel forged.

Code	Desc.	N. arms	Opening mm	Depth mm
4430021100	284 - 2x80	2	80	75
4430021110	284 - 2x120	2	120	100
4430021120	284 - 2x140	2	140	100
4430021130	284 - 2x180	2	180	140
4430021140	284 - 2x250	2	250	250
4430021150	284 - 2x300	2	300	300

## Universal extractors 3-arm

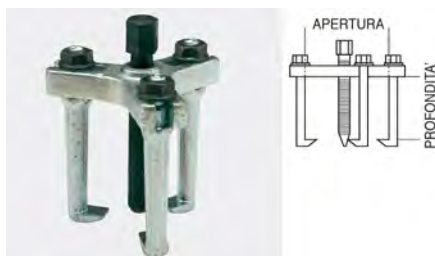

- Puller Tool universal 3-arm for interior and exterior steel forged.

Code	Desc.	N. arms	Opening mm	Depth mm
4430021200	285 - 3x90	3	90	75
4430021205	285 - 3x120	3	120	100
4430021210	285 - 3x160	3	160	100
4430021220	285 - 3x190	3	190	140

## Arms parts for extractors



- Arms parts for extractors at 2 and 3 arms our art. cod. 443 284/285.

Code	Desc.	Depth mm
4430021310	286 - 120	100
4430021320	286 - 140	100
4430021325	286 - 160	100
4430021330	286 - 180	140
4430021340	286 - 250	250
4430021350	286 - 300	300

## Bearing puller



- For the extraction of all types of ball bearings which can not be grasped neither internally nor externally.
- The special adapters fitted between a sphere and the other and rotated 90 ° constitute a robust and secure grip.
- For the extraction of bearings mounted on: induced, sump, gearbox shafts, etc.
- Bearing  $\varnothing$  20 to  $\varnothing$  95 mm.

### INSTRUCTIONS FOR USE

- 1) Drill the bearing cage in two diametrically opposed points.
- 2) Plug the adapters into the holes.
- 3) Turn the adapters of 90° degrees.



Code	Desc.	Use range mm
4770000020	2	20-95

## Puller Tool universal 2-arm



- Puller Tool universal 2-arm for internal and external.
- Legs gripping ultra-thin (2 mm).
- The 6 arms included allowing a very wide scope.
- Opening 160 mm max.

**AMPIO CAMPO DI APPLICAZIONE!**

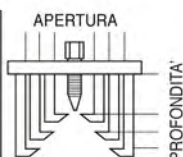

Code	Description	Lunghezza bracci
4770001980	198	90-200-250 mm
4770001981	198 R FOOT REPLACEMENT	-

## Extractor wiper and battery terminals with 2 arms



- Puller two arms suitable for wiper and battery terminals.
- Article suitable for body shops, windshield replacement centers, workshops, elettrauto.
- The particularly reduced dimensions and the ultra strong material makes the article particularly suitable for the removal of wiper arms.
- Size: 6mm opening min, max opening 36mm, depth max 25mm.

Code	Description
4770005390	641 - Extractor wiper and battery terminals

## Stud extractor



- Extractor roller hanger bolts or damaged screws.
- Allows the screwing and extracting stud bolts without damaging the threads.
- 1/2 square drive, external hexagon of 22 mm.
- Chrome steel-vanadium.

Code	Desc.	For screws m	a mm	L mm
4430040851	459/1 - 6	6	25	65
4430040852	459/1 - 7	7	25	65
4430040853	459/1 - 8	8	25	65
4430040855	459/1 - 10	10	29	75
4430040857	459/1 - 12	12	29	75
4430040858	459/1 - 14	14	29	75

## Extractor cam for hanger bolts



- Galvanized steel.
- Hexagonal connection maneuvering.

Code	Desc.	For screws diameter mm	Hexagonal wrench mm
4430024510	311-5-20	5-20	27

## Strippers claims for damaged screws

- Conical extractors for damaged screws.
- Simply drill the screw-introduce the appropriate extractor and turn to the left to pull the screw.
- The best use is in 1/3 closer to the shank, the following table recommends diam. of drilling, where possible to practice them.

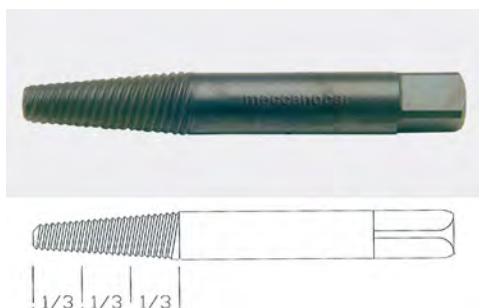

Code	Desc.	For screws m	Ø punta consigliata mm
4430024600	312 - 3 - 6	3 - 6	2
4430024610	312 - 6 - 8	6 - 8	2,5
4430024620	312 - 8 - 11	8 - 11	3,5
4430024630	312 - 11 - 14	11 - 14	5,5
4430024640	312 - 14 - 18	14 - 18	7
4430024650	312 - 18 - 24	18 - 24	10,5
4430024660	312 - 24 - 33	24 - 33	13,5
4430024670	312 - 33 - 50	33 - 50	18,5

## Series extractors claims for damaged screws



Code	Desc.	N. Pieces	For screws
4430024700	313	5	3 - 18 mm
4430024800	314	6	3 - 24 mm
4430024900	315	8	3 - 50 mm



## Extractor kit for broken bolts



Dim.232x167x54



- Extractor kit for broken bolts 11 pcs
- Extractors in special steel with a 3/8" - 1/2" square attachment
- From diameter 2 to diameter 7 with a 3/8" square attachment
- From diameter 8 to diameter 16 with a 1/2" square attachment
- Supplied in a plastic case
- **N.B. Drill the broken bolt to utilise the extractor kit correctly. Insert the extractor with an adequate diameter into the hole until a secure grip is felt, then rotate in an anticlockwise direction.**

Code	Description
4430057880	1777-Kit estrattori viti rotte 2-16

Spare Parts				
Attacco quadro	Code	Description	Diam. mm	L mm
3/8	4430057890	1777-2-3/8- estrattore	2	60
3/8	4430057900	1777-3-3/8- estrattore	3	60
3/8	4430057910	1777-4-3/8- estrattore	4	60
3/8	4430057920	1777-5-3/8- estrattore	5	60
3/8	4430057930	1777-6-3/8- estrattore	6	60
3/8	4430057940	1777-7-3/8- estrattore	7	60
1/2	4430057950	1777-8-1/2- estrattore	8	78
1/2	4430057960	1777-10-1/2- estrattore	10	78
1/2	4430057970	1777-12-1/2- estrattore	12	78
1/2	4430057980	1777-14-1/2- estrattore	14	78
1/2	4430057990	1777-16-1/2- estrattore	16	78

8

## Compass needle for hexagonal screws



- Compass variable opening to tighten or loosen hex head screws also ruined.
- The special needles Contour on the head providing a secure grip.
- Range: 7 to 19 mm and 1/4 to 3/4 ".
- Female square 3/8.

Code	Desc.	Attachment □	For screws TE mm	For screws TE inch
4430044970	525	3/8	7 - 19	1/4 - 3/4



## Tensioning springs shock absorbers



- Brackets for mounting and dismantling of all the springs to drive spiral.
- Maximum length of 320 mm compression.
- Special steel, to be used with hand tools.

Code	Desc.
4770000060	6

## Extractor heads steering 4 position

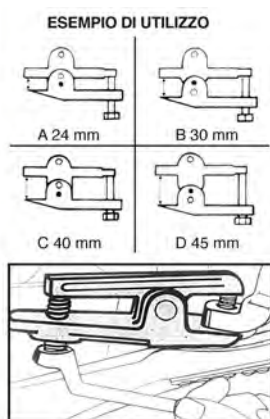

- This type of extractor is adjustable by means of a locking pin.
- It is used in places and on heads that would not be removed with normal equipment.
- Fork opening 19 mm.
- For cars.

Code	Desc.	Fork opening mm
4770001260	126	19

## Strippers steering heads



- Strippers universal ball joints and tie rods.
- Fine milling of the fork does not damage the oil seals.
- For cars with opening fork 19 mm.
- For commercial vehicles and trucks with 30 mm fork opening.

Code	Desc.	Fork opening mm
4770000130	13	19
4770000131	13/1	30

## Puller Set to electrical terminals



- Complete set of extractors specific for the disassembly of the electrical terminals with retaining tooth by the blocks, without causing damage. terminals cts extraction may be recycled.
- Indispensable to elettrauto, electricians, repairmen electronics, appliances, auto repair in general, etc ..
- Can be used on electrical systems of cars, motorcycles, trucks, civil, electronics, computers, appliances, etc..
- The range comes complete, includes 12 different tools with different shapes and sizes, to all terminal types: round, flat, pin, bush, etc ..

Code	Desc.
3170026210	52755

## Remove steering rods



- Universal device that allows you to assemble and disassemble the ring nuts of the steering tie rods without removing the steering gear.
- Not having to disassemble the steering box from its housing, the operator has a considerable saving of time.
- For tightening use a torque wrench.
- Compass with special roller device of internal diameter 35 to 45 mm.

Code	Desc.	Length mm
4770001160	116	400

## Puller inner rings wheel hubs



- This device is able to extract the inner rings that are stranded on the hubs when removing the bearing from the wheels.
- With self-locking effect you can remove any type of bearing ring, including those without milling, such as those found on the hubs of the latest VW cars.
- The apparatus of the universal type, it is enough to know the  $\varnothing$  inside and outside of the bearing to be extracted for the choice of appropriate caliper.
- Passenger car group Fiat, VW / Audi, Citroen and Renault.

### CONTENT

- 1 Basic device
- 1 forceps extraction from 40 to 45 mm
- 1 forceps extraction from 45 to 51 mm
- 1 forceps extraction from 51 to 55 mm
- 1 forceps extraction from 55 to 61 mm.

Code	Desc.	Application
4770002010	201	FROM 40 TO 61 mm

Spare Parts	
Code	Description
4770002013	Forceps extraction from 40 to 51 mm
4770002015	forceps extraction from 55 to 61 mm

## Deposit spacers for bearings and hubs



- Deposit composed of 7 spacers to extract and insert bearings and hubs.
- Each piece is numbered to avoid confusion with the application table that accompanies the tape.
- Thanks to these spacers the extraction of the bearings with the aid of the press becomes a work quickly and safely.
- It is avoided the danger of breakage of the hub as the spacer is shaped in such a way as to work the piston of the press perpendicularly to the bearing.
- Particularly suitable for all workshops cars and SUVs.

### CONTENUTO CASSETTA:

N° 121: DISTANZIALE PER CUSCINETTI RENAULT  
 N° 122: DISTANZIALE PER CUSCINETTI PEUGEOT  
 N° 123: DISTANZIALE PER CUSCINETTI FIAT E VW GOLF  
 N° 124: DISTANZIALE PER CUSCINETTI CITROEN  
 N° 125: DISTANZIALE PER CUSCINETTI PEUGEOT 205  
 N° 126: DISTANZIALE PER ESTRARRE MOZZI RENAULT  
 FIAT - VW - PEUGEOT - ALFA - LANCIA  
 N° 127: DISTANZIALE PER ESTRARRE MOZZI FORD  
 MONDEO - ESCORT - FIESTA E FUORISTRADA.

Code	Description
4770002400	240 - Spacer kit

## Multifunction extractor



- Extractor combined
- Flexible rod that allows you to enter even in narrow parts and uncomfortable.
- Magnet in the head and jaws for
- Retention and taking part.
- With LED light to better identify the piece to be recovered.



Code	Description	Length mm
4430056850	1790	650

## Flexible arm with magnet tip



- He raises up to 500 grams. of weight.
- Tip diameter 14mm.

Code	Desc.	Length mm	Capacity lift
4430025000	316	580	500 Gr.

## Telehandlers pocket



- More convenience with its small footprint, it puts in the pocket like a pen.
- High lifting capacity.

Code	Desc.	Length mm	Capacity lift
4430025010	316 T. 350	450	350 Gr.
4430025020	316 T. 760	450	760 Gr.



## Wad with needles for extracting radio



- Product useful for extractions radio.
- Practical, tough and especially indispensable to operate with efficiency and speed.
- Thanks to the universal set of needles contained within it can extract the kit car radios of almost all automakers.
- Absolutely it does not damage the car radio and its box.

### HOW TO USE:

- Apart the tow.
- Choose the appropriate needle for each brand.
- Pull the car radio.



Code	Desc.
4770003095	310



## Mounting Kit elastic straps



- Specific kit to put on without risks of damaging the new elastic belts on the pulleys
- The kit is suitable for belts of width 32mm and 50mm
- Suitable for car workshops
- Kit Components:
- 1 calzatore width 32 mm
- 1 calzatore width 50 mm ..
- 1 screw M8x25 mm diam.5,9
- 1 screw M8x40 mm diam.5,7
- 1 screw M8x65 mm diam.5,6



Code	Description
4770005850	708



## Universal kit for the extraction of the silent block



- Practical kit for the extraction of the silentblock from the seat without risk of breakage.
- The series of details that comes with the kit allows you to operate on all the current arrangements for silent blocks that are normally mounted on the vehicle fleet.
- For car workshops.
- The silent blocks must be replaced when you hear loud and annoying metallic noise during braking or when taking holes or bumps.
- Content: 20 different bushings to work on all sizes of silent blocks on the market; 6 different washers to be used with the various rubber bushings during the operations of extraction and / or introduction of silent blocks; Screws for extraction and / or introduction.

Code	Description
4770005860	709

Spare Parts	
Code	Description
4770005864	Barra filettata M16x1,5 con 2 dadi
4770005863	Barra filettata M14x1,5 con 2 dadi
4770005862	Barra filettata M12x1,5 con 2 dadi
4770005861	Barra filettata M12x1,5 con 2 dadi

8

## Pneumatic glowplug extractor



- Ideal for workshops
- Pneumatic impulse extractor for glowplugs
- Ideal for blocked glowplugs
- Can be utilised in four torque settings: 10-20-30-40 Nm to unblock glowplugs
- Supplied with 5 x special 1/4" attachment extended sockets for glowplugs:
- Supplied in a metal case
- **Complete with:**
- 5 x 1/4" extended sockets, measuring 8-9-10-11-12 mm
- 2 x extensions
- 1 x universal joint

Code	Description
4180008670	Pneumatic glowplug extractor

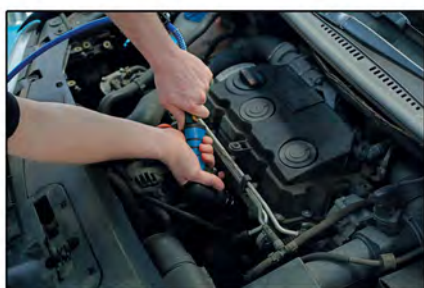

Spare Parts	
Code	Description
4430057780	Bussola 1/4 lunga 8mm
4430057790	Bussola 1/4 lunga 9mm
4430057800	Bussola 1/4 lunga 10mm
4430057810	Bussola 1/4 lunga 11mm
4430057820	Bussola 1/4 lunga 12mm
4430057830	Prolunga 1/4 50 mm
4430057840	Prolunga 1/4 100 mm
4430057850	Snodo 1/4

**Kit estrazione candele rotte**



La richiesta di utensili che possano andare ad estrarre la parte della candelette che rimane all'interno del blocco motore è in forte aumento, non che le candele di preriscaldamento siano così difettose, ma il più delle volte la loro sostituzione è a causa di una mancata manutenzione del mezzo.

I produttori e le case madri consigliano di controllarle tra gli 80.000 e i 100.000 km, e se, come sempre più spesso accade, questo non succede portando le candele a fine vita, esse sono più sottoposte a rotture, soprattutto quando arriva il momento di smontarle per sostituirle.

La candelette generalmente si spezza sotto la testa di forma esagonale, per cui il corpo rimane nella sede con la parte finale, e a questo punto iniziano i problemi. La rimozione può essere effettuata solamente in 2 modi: il più lungo e costoso è quello che vede lo smontaggio della testata e la rimozione dalla parte interna della candelette rotta. Oggi però esistono in commercio dei kit dedicati per la rimozione sicura della parte rotta della candelette senza dover smontare la testata.

Molti produttori hanno creato kit dedicati a questo scopo, pertanto se un meccanico intendesse avere tutto quanto occorre per intervenire in questi casi, dovrebbe acquistare non meno di 7-8 kit con un notevole impegno economico.

Sul mercato esistono candele di varie misure, M8x1 - M9x1 - M10x1 - M10x1,25, pertanto in base al tipo di vettura se ne possono trovare diverse.

Alcuni esempi:

- M8x1:               motori mj1.3 - 2.3 - 3.0  
                          Mercedes cdi
- M9x1:               Mercedes vecchi modelli
- M10x1:             Mercedes cdi  
                          Renault dci 1.5 - 1.9 - 2.2 - 2.5  
                          Renault 2.0 cdi  
                          Peugeot 2.0 hdi

Per venire incontro alle esigenze di mercato, ma soprattutto dei nostri clienti, abbiamo studiato in collaborazione con dei produttori qualificati un kit UNIVERSALE che consente, grazie alla precisione e alla qualità dei componenti, di assolvere in pieno a quanto richiesto: l'estrazione di qualsiasi tipo di candelette su qualsiasi modello attualmente circolante.

**Kit per l'estrazione dell'elettrodo**



Sempre nella stessa ottica abbiamo anche creato un Kit Universale per l'estrazione dell'elettrodo, cioè la parte finale della candelette che può rimanere nella sede, e che senza i giusti attrezzi diventa impossibile da rimuovere. Per questo tipo di operazione siamo veramente tra i pochi a poter dare una valida soluzione.



## Puller plugs routes with system blowback

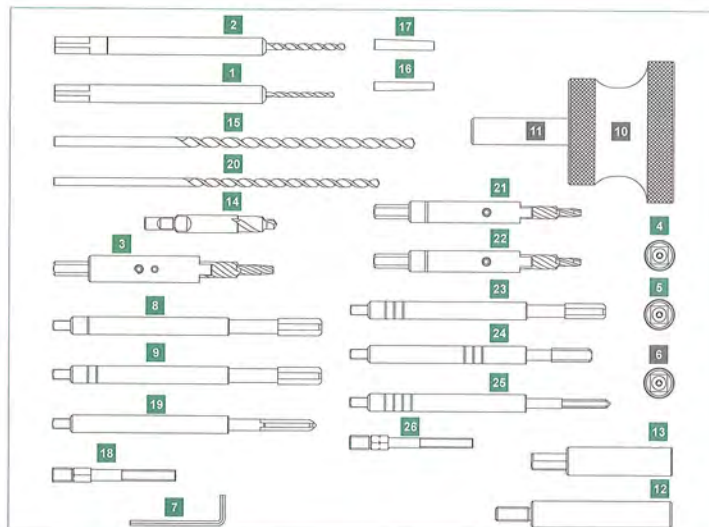
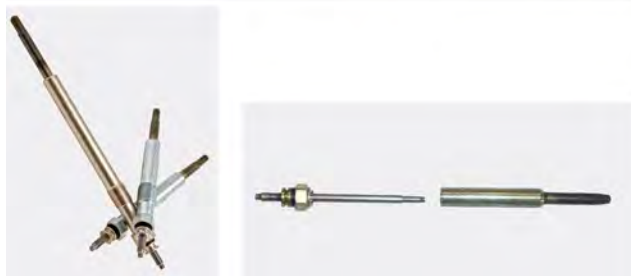

- Complete extractor for extracting broken plugs preheating diesel engine without removing the head.
- Kit suitable for plugs diameters: 8x1-9x1-10x1 and 10x1,25.
- Through the various tools supplied you can remove the plugs routes from all types of vehicles.
- For car workshops.

8

Code	Desc.	For glow plugs
4770005940	716	8x1-9x1-10x1-10x1,25

Spare Parts		
Code	Description	Figure
4770005960	716B-extension + tip d.2,7	1
4770005950	716A-extension + tip d.3,6	2
4770005990	716E-extension + pointing double-d.8,9 d.5,5	3
4770006082	Roller extraction bush d.2.5	4
4770006084	Roller extraction bush d.2.5	5
4430012910	Allen key 2.5 mm	7
4770006030	716I male M10x1 with extension	8
4770006040	716L-male M10x1,25 with extension	9
4770006090	Extension d.15 mm for extraction pin	12
4770006091	Extension d.16 mm with grain for tool holder	13
4770006000	716F-pointing double-d.8,9 d.5,5 short	14
4770005970	716C-twist drill cylindrical d.5,5	15
4770006088	Guide sleeve for drilling d.2,7 mm	16
4770006089	Guide sleeve for drilling d.3,6 mm	17
4770006086	1/4 "threaded insert	18
4770006050	716m-male 1/4 "-28unf with extension	19
4770005980	716D-twist drill cylindrical d.4,5	20
4770006020	716H-tip d.7-d.4,5	21
4770006010	716G-tip d.8-d.4,5	22
4770006060	716n-male M9x1 with extension	23
4770006070	716 O-male M8x1 with extension	24
4770006080	716P-male 12-28 unf with extension	25
4770006087	Threaded insert 12-28	26



## Extractor for the tungsten tip of the glow plugs preheating



- The glow plug can break in two places: in the body and then you have to use the kit 4770005940, or on the tungsten tip that stays inside the headquarters of the glow plug.
- The kit allows you to drill precisely the tip of the glow plug in tungsten and then through the various tools, and removed without removing the cylinder head.
- Kit suitable for plugs diameters: 8x1-9x1-10x1 and 10x1, 25
- For car workshops

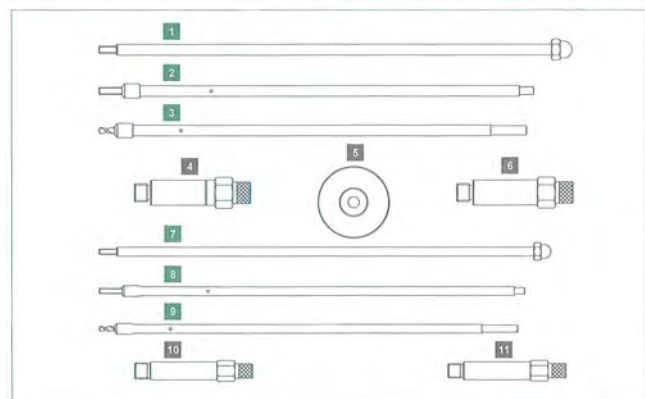

Code	Desc.	For glow plugs
4770006100	717	8x1-9x1-10x1-10x1,25

Spare Parts		
Code	Description	Figure
4770006112	M4 extraction rod with assembled nut	1
4770006110	717A-male m4 with extension	2
4770006120	717B-tip d.3,2 with extension	3
4770006132	M3 extraction rod with assembled nut	7
4770006130	717C-male m3 with extension	8
4770006140	717D-tip d.2,5 with extension	9

## Kit integrazione estrazione tungsteno



- Set of tools for the extraction of the end of the electrode of incandescent glow plugs in case of breakage or seizure inside the seat, otherwise impossible to remove.
- The set includes all the tools necessary to safely remove the terminal part of the electrode of the glow plug without damaging the cylinder head. This operation becomes very simple and fast.
- The alternative is to dismantle the headboard, saving time becomes therefore considerable.

Code	Desc.
4770006148	717-M8



## Kit for the extraction of the electro-injectors



Foto 1

Foto 2

Foto 3



Foto 4

Foto 5

Foto 6



- Kits for the extraction of the electro-injectors with system blowback.
- Usable on electro-injectors: Bosch, Delphi, Siemens.
- Complete with accessories.
- Suitable for car workshops and cargo.

8

Code	Desc.	For electro-injectors
4770006150	718	Bosch,Siemens;Delphi

Spare Parts		
Applications	Code	Description / Measure
Compass for removing injectors Siemens electrical connection 1/2 "	4770006170	718-25 Foto 1
Compass for removing injectors Siemens electrical connection 1/2 "	4770006180	718-27 Foto 2
Compass for removing electrical connection injectors Bosch 1/2 "	4770006190	718-28 Foto 3
Compass for removing electrical connection injectors Bosch 1/2 "	4770006200	718-29 Foto 4
Compass for removing electrical connection injectors Bosch 1/2 "	4770006210	718-30 Foto 5



## Cazzuola per muratori



- Tipo a punta tonda stretta.
- Impugnatura ergonomica in legno.
- Lama in acciaio forgiato.
- Modello indicato per muratori, elettricisti ed idraulici

Code	Desc.	Measure mm
4430056750	1784-180	180

## Cazzuola punta acuta per muratori



- Tipo a punta
- Impugnatura ergonomica in legno
- Lama in acciaio forgiato
- Modello indicato per muratori, elettricisti ed idraulici

Code	Desc.	Measure mm
4430056746	1783-140	140

## Mazza da minatore con manico in legno



- Mazza per demolizione con manico in legno da cm80
- Testa in acciaio forgiato e temprato, verniciata a polvere epossidica
- Battenti spigolati e lucidati
- Particolarmente indicata per lavori di demolizione.

Code	Desc.	Weight Kg.
4430056800	1786/4	4
4430056801	1786/5	5
4430056802	1786/M	manico in legno ricambio

## Mazza da minatore con manico infrangibile

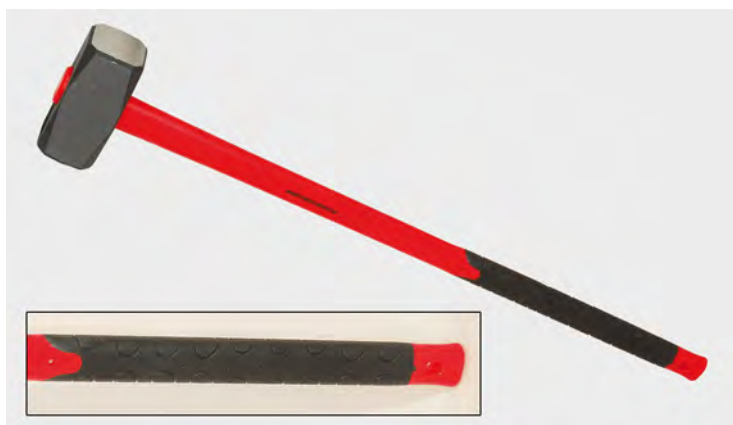

- Mazza per demolizione con manico infrangibile impugnatura ergonomica
- Testa in acciaio forgiato e temprato, verniciata a polvere epossidica
- Battenti spigolati e lucidati
- Particolarmente indicata per lavori di demolizione.

Code	Desc.	Weight Kg.
4430056804	1786I/4	4
4430056805	1786I/5	5
4430056806	1786MS	manico in sintetico ricambio

## Badile da carpentiere con manico in legno



- Badile con manico
- Manico in legno 140cm.
- Pala in acciaio temprata e verniciata a polvere epossidica.
- Utensile indicato per edilizia, idraulica, ecc..

Code	Desc.	Weight Kg.
4430056810	1787	1,9
4430056812	1787/M	manico in legno ricambio

## Badile da carpentiere con manico infrangibile



- Badile con manico
- Manico infrangibile 140cm.
- Pala in acciaio temprata e verniciata a polvere epossidica.
- Utensile indicato per edilizia, idraulica, ecc..

Code	Desc.	Weight Kg.
4430056811	1787	1,9
4430056813	178MS	manico in sintetico ricambio

8

## Piccone con manico in legno



- Punta in acciaio di alta qualità,
- Acciaio forgiato e temprato, con vernice trasparente.
- Occhio ovale
- Utensile indicato per edilizia, idraulica, ecc..

Code	Desc.	Weight Kg.
4430056820	1788	1,5
4430056821	1788/M	manico in legno ricambio

## Piccone con manico infrangibile

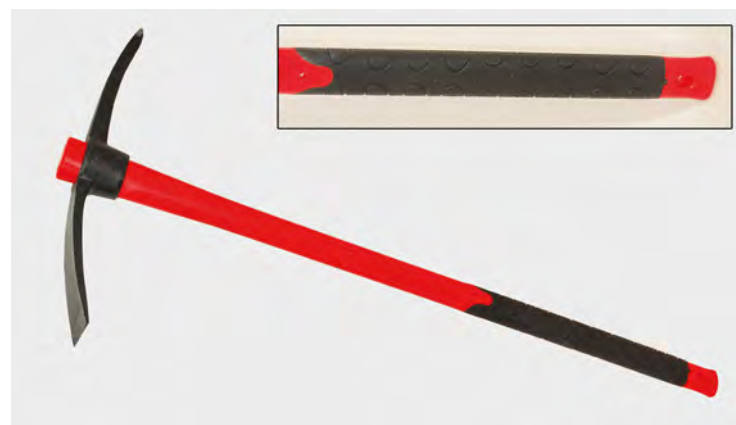

- Manico sintetico 90 cm con presa ergonomica
- Punta in acciaio di alta qualità
- Acciaio forgiato e temprato, con vernice trasparente.
- Occhio ovale
- Utensile indicato per edilizia, idraulica, ecc..

Code	Desc.	Weight Kg.
4430056822	1788I	1,5
4430056823	1788MS	manico in sintetico ricambio

## Aluminum shovel for snow and grains



- Pala con manico in legno
- Particolarmente leggera, si adatta a molteplici impieghi

Code	Desc.	Weight Kg.
4430056970	1805	1,4
4430056812	1787M	manico in legno ricambio

## Secchio per muratore



- Secchio tipo extra.
- In polietilene ,con nervature per una lunga durata.
- Colore rosso per una rapida identificazione.
- Con manico in ferro zincato
- Indicato per edili, idraulici ed elettricisti.

Code	Description	Diameter mm
4430056835	1789R	340

## Secchio per muratore



- Secchio tipo normale.
- In polietilene ,colore nero.
- Con manico in ferro zincato.
- Indicato per edili, idraulici ed elettricisti.

Code	Description	Diameter mm
4430056832	1789N	340

## Cassa per malta



- In polietilene nero
- Con rinforzo in ferro

Code	Desc.	Measures (mm)
4430056960	1804 G	620 x 430 X 150
4430056965	1704 G	670 X 450 X 180

## Kit timing: introduction

- The kits timing should always be identified taking into account the engine code indicated on the registration certificate of the vehicle.

### Kit timing engine Alfa Romeo 105 1.6 eco hp gasoline



- The kit consists of 2 aluminum caps.
- Each cap is marked with the number of the cylinder is positioned and where it should be placed at the suction side "A" or drain "S".

130A-130S (2° & 3° cilindro):

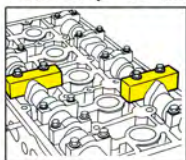

Code	Desc.
4770002550	255

8

### Kit caps Fiat, Alfa, Lancia



- Updated version to 2001.
- Aluminum caps with marking for easy identification of the application.
- Each cap is marked with the n° of the cylinder should be positioned and where it should be placed in correspondence of the suction side "A" or the drain "D".
- The kit contains 25 caps in aluminum. Particularly suitable for workshops and car dealerships.

Code	Desc.
4770002540	254

ART.	CAMME	CIL. N°	MOTORE	N° PEZZI	ART.	CAMME	CIL. N°	MOTORE	N° PEZZI
00	A	2	FIAT Bravo/Bravo-Lancia 110 1.4 12V	1	70	A	3	FIAT Bravo/Bravo/Marea 2.0 20V	2
10	A	3	LANCIA K S C. Z.0 2.0V MOT. VS '96	2	70	S	2		
10	S	2			80	A	2	FIAT Barchetta/Coupe 1800 16V con variatore	2
20	A	1	ALFA 3.0 V6 24V	2	80	S	3		
20	S	1			90	A	2	ALFA 145/146 1400 16V - 1600 16V	2
21	A	6		2	90	S	3	(Motore Step-At)	
21	S	4			100	A	2	ALFA 156 1600 16V - ALFA 145/146 1400 e 1600	2
40	A	3	LANCIA SC. PRECEDENTE-AL '96	2	100	S	3	ALFA 155 1600 16V	
40	S	2			105	A	2	ALFA 156 1800-2000 16V - Spider e Ch TS 2000	2
50	A	2	FIAT Bravo/Bravo/Marea - LANCIA 1800 16V 115CV	2	105	S	3	155 TS 1800	
50	S	3	Delta/Dedra 1800 16V 1860 847/C/2		120	A	3	FIAT 2.0 Turbo - LANCIA 2.0 Turbo	2
60	A	2	FIAT Coupe - LANCIA - ALFA 1800 16V 130CV	2	120	S	2		
60	S	3	ALFA 155						

A= Aspirazione S= Scarico

## Kit for the timing of the engine of the new engines 1.9-2.4 JTD Multijet 140hp-175CV, Alfa, Fiat, Lancia

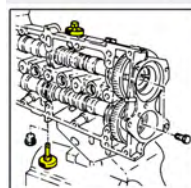

- Models: Alfa 145, 146, 147, 156, 1.9 JTD 16v., 156 2.4 JTD 20v., 166 2.4 JTD 20v., Gt 2.4 jtd 20v. Fiat Punto, Grande Punto, Brava / Bravo Marea Weekend, Stilo, Doblo / Cargo, Multipla 1.9 JTD 16v. Lancia Lybra 1.9 JTD 16v., Lybra 2.4 JTD 20v., Thesys 2.4 JTD 20v.
- Engines: 1.9-2.4 JTD
- Engine codes: 323.02,371.01, 182B4.000, 182B9.000, 186A6.000, 188A2.000, 188A7.000, 188B2.000, 192A1.000, 192A3.000, 937A2.000, 939A1.000, 192A5.000, 192B1.000, 937A5.000, 939A2.000, 325.01, 342.02,362.02, 185A6.000, 841C.000, 841G.000,939A3.000, 940A3.000, 940A4.000.
- With instructions included.

Code	Desc.
4770005600	660

## Kit timing engine Alfa Romeo 2.0 JTS 165 hp

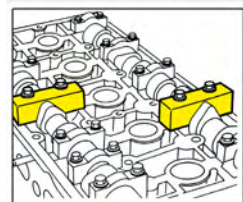
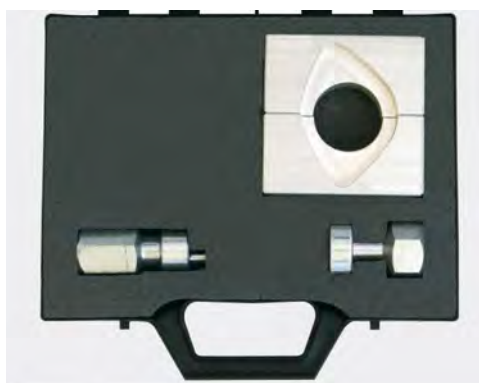

- Cap 150A-150S (cylinders: 2nd & 3rd).
- Models: 2.0 gt jts.
- Engine codes: 937A1.000, 932A2.000.
- With instructions included.

Code	Desc.
4770005570	654

## Tensioner eccentric for Alfa Romeo



- New cam tensioner for tensioning roller mounted on the new Alfa Romeo Alfa 156-166-147 see gasoline.
- Indispensable when replacing timing belt and timing.
- With instructions included.

Code	Desc.
4770002560	256



## Kit timing engines BMW 320d, 330d, 530d, 730d Diesel

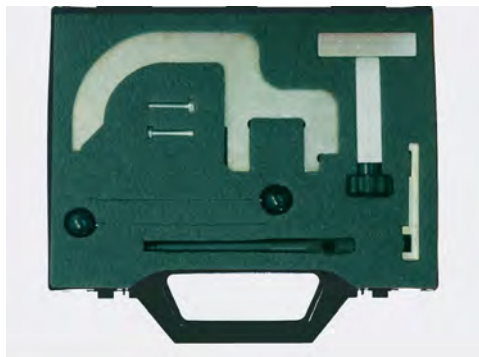

- Models: 320D, 330D (E46), 520D, 530D (E39) (98-04), 730D (E38).
- suitable for: Land Rover Freelander (TD4) MG-Rover 75 2.0 CDT / cdti (99-04) -04).
- Engine codes: M47, M57 (chain), 30 6D 2.
- With instructions included.

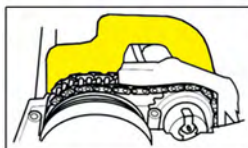

Code	Desc.
4770002990	

## Complete kit for the timing of the petrol engines BMW 1.8 - 2.0 N42 & N46 (chain)

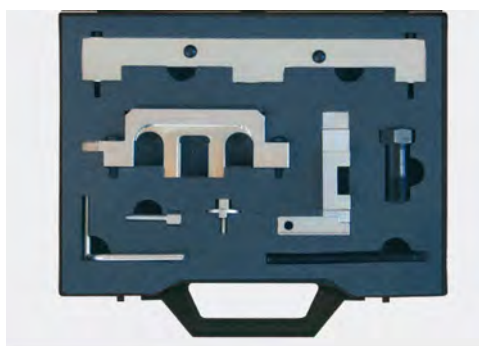

- Models: 118i - 120I, 316i - 318I, 316TI - 318 TI.
- Engines: 1.8, 2.0.
- Engine codes: B18, b20.
- With instructions included.

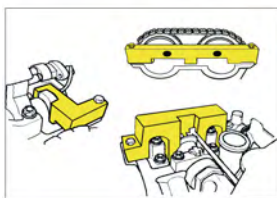

Code	Desc.
4770005575	655

## Complete kit for the timing of the petrol engines BMW 1.6 N40, N45 & N45 (belt)

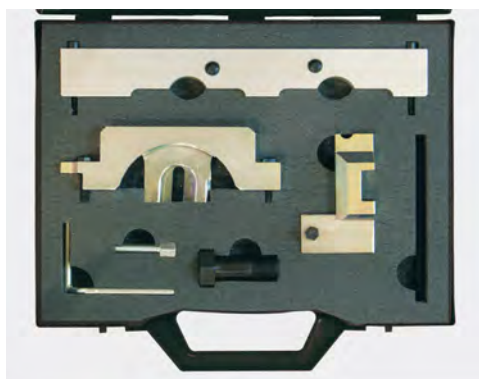

- Models: 116i. E81 / E87, 316i. E46 / E90, 316CI. E46, 316TI. E46.
- Engines: 1.6
- Engine codes: B16A B40, B16 to N45, N45 B16 AC.
- With instructions included.

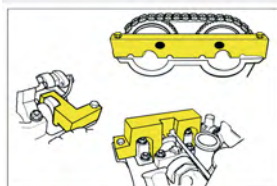

Code	Desc.
4770005580	656

## Complete kit for the timing of the BMW diesel engines 2.0



- Models: 118D. E81 / 87 (06-09) 120D. E81 / 82/87 (06- 09) 123D. E81 / 82/87 (07-09) 318D. E90 / 91 (07-09) 320D. E90 / 91/92 (05-09) 520D. E60 / 61 (06-08) X3. 2.0D. E83 (07-09).
- Engines: N47 & N47S:
- Engine codes: D20A, D20.
- With instructions included.

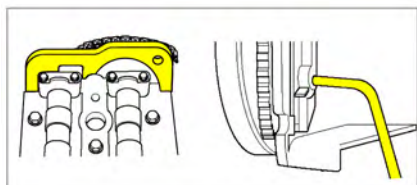

Code	Desc.
4770005585	657

## Injection pump pulley puller BMW engines



- Models: M47 (only extractor).
- M47TU (extractor & centering bushing).
- M57 (puller & centering sleeve).
- M57TU (puller & centering sleeve).
- Including: centering sleeve, measuring m 40x1,5 mm. Centering bushing, measure m 42x1,5 mm.
- **Caution: during the removal operation of the injection pump always use together with the centering bushings also the extractor.**

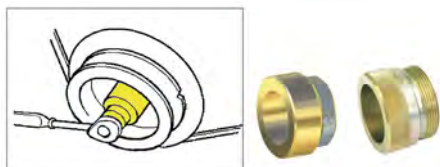

Code	Desc.
4770005590	658

## Injection pump pulley puller BMW engines



Code	Desc.
4770005595	659

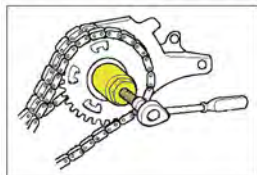

## Kit timing MINI - PSA 1.4-1.6 16v N12 & N14

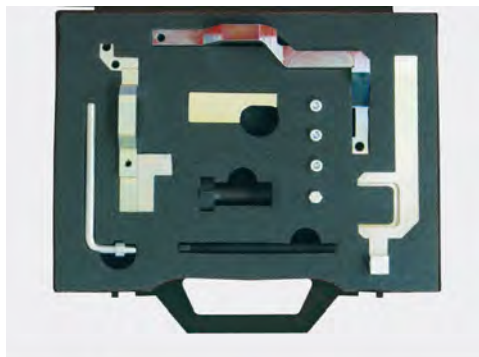

- Models: Mini One, Mini Cooper, Mini Cooper S, Citroen C4 - C4 Picasso, Peugeot 207, Peugeot 308.
- Engines: 1.4 - 1.6. petrol
- Engine codes: R55 - R56, EP3 - EP6, EP6DT / DTS.
- With instructions included.

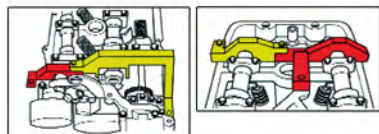

Code	Desc.
4770005630	666

## Kit 4 pcs for the timing of the engine Fiat Punto 1.2 and 1.4 16V



- Models: Punto, Bravo, Brava, Marea, Palio Weekend, Stilo. Engine: 1.2 16v, 1.4 16v.
- Engine codes: 176B9.000, 182B2.000, 188A5.000, 843A1.000.
- Complete kit for the timing of engines 1.2 16V tensioner complete with 1/4 to be used in conjunction with a normal ratchet 1/4 see 488 00 33810-415 allowing you to do this in absolute tranquility.
- The kit also comes with eccentric tensioner for tensioning roller motor of grupo fiat except 1.2 16V engines.
- **With illustrations for use.**



Code	Description
4770002220	222 Kit
4770002230	223 - 1.2 16V engines Tensioner

## Piece for timing engine Fiat 1.4 16v



- For engines not multi-air.
- The block must work in conjunction with the kit 4770002220
- Factory authorized and not



Code	Desc.	OEM
4770002221	222/1	2 000 015 800

## Kit timing petrol Fiat 1.6 16v



- Models: Bravo, Brava, Marea, Palio Weekend, Stilo, Multipla.
- Engines: 1.616v.bipower, BluPower
- Engine codes: 178B3.000, 182A4.000, 182A6.000, 182B6.000, 186A4.000, 182B6.000, 186A3.000.
- Tensioner double pin M8 and M10.

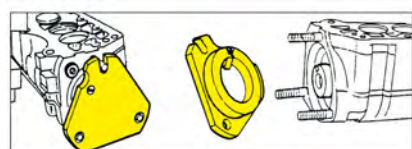

Code	Desc.
4770002571	257/1

## Kit timing camshaft and crankshaft of the Fiat Ducato 2.3 JTD Diesel



- Models: Ducato, Iveco Daily.
- Engine: 2.3 JTD.
- Engine code: F1AE048IC, F1CE048ID, F1AE048IA, F1AE048IB, F1CE0481A.
- With instructions included.

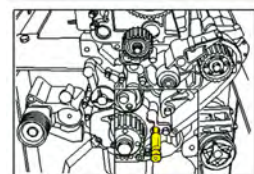

Code	Desc.
4770002970	297



## Kit phasing new petrol engines Fiat 1.2 8v, Fiat 1.4 8v Fire Evo 2



- Models: the Fiat Idea, Punto, Grande Punto, Stilo, Panda, 500, Bravo, New Point, New Panda Lancia Ypsilon, Musa.
- Engines: 1400 fire evo 2, 1400 16v. 95 hp. Starjet, 1400 16v. 100 hp. Starjet, 1400 16v. 90 hp. Starjet, 1400 16v. 120 hp. t-jet, 1400 16v. 150 hp. t-jet. -jet, bi-fuelgpl 1.4, 1.4 Natural Power methane.
- Engine codes: 350A1.000, 169A4.000, 199A4.000
- With instructions included.

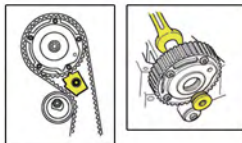

Code	Desc.
4770004690	329

## Tools timing crankshaft and camshaft of the new engines Fiat, Lancia, Opel, Suzuki 1.3 Multijet 16V



- Models: Punto, Panda, Idea, Doblo, Doblo Cargo, Stilo, Ypsilon, Musa, Corsa, Agila, Meriva, Combo tour, Ignis, Swift, Vagon R +.
- Engines: 1.3 multijet, 1.3 cdti, 1.3 ddis.
- Engine codes: 188A8.000, 188A9.000, 199B1.000, 199B2.000, 199A2.000, 199A3.000, 169A1.000, 199A9.000, 223A9.000.
- With instructions included.

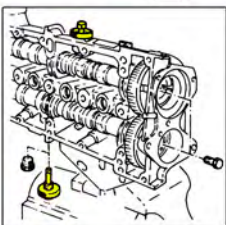

Code	Desc.
4770002910	291

## Timing tool new petrol engines Fiat Panda 1.2

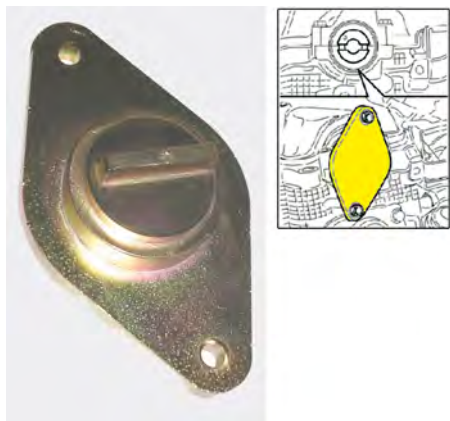

- Models: Point, New Point, New Panda.
- Engines: 1.2 8v.
- Engine codes: 188 A4.00.

Code	Desc.
4770003020	302



## Kit specific timing for commercial vehicles with engines 2.2-2.3-3.0 MJ

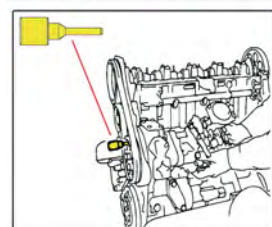

- Models: the new Fiat Ducato, Iveco Daily, Van Ford Transit, Peugeot Boxer, Citroen Jumper.
- Engines: 2.2 JTD, 2.3 JTD, 3.0 JTD
- Engine codes: 4HV, F1AE0481D, F1AE0481N, F1CE0481D, F1CE0481F, F1CE0441F, F1CE0481H, F1AE0481R, F1AE0481G, F1AE0481F, F1AE0481H, P8FA, QVFA, QWFA, P8FB, SRFA, PGFA, PGFB, SRFB, SRFC, SRFD, SRFE, P22DTE (4HV ), P22DTE (4HU), 4HV (P22DTE), 4HU (P22DTE).
- With instructions included.

Code	Desc.
4770005605	661

## Kit timing petrol Fiat & Alfa 1.4 MultiAir

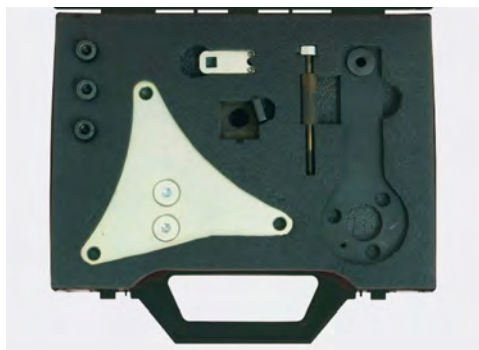

- Models: Alfa Romeo Mito, Alfa Romeo Mito green cloverleaf
- Engines: 1.4 Multiair 16v 105cv, 1.4 Multiair Turbo 16v 135cv 170cv &
- Models: Alfa Romeo Giulietta
- Engines: 1.4 Multiair Turbo 16v 170cv.
- Models: Fiat Punto Evo
- Engines: 1.4 multiair start & stop 105cv 16v, 1.4 16v turbo multiair start & stop 135cv.
- Models: Fiat Bravo
- Engines: 1.4 Multiair Turbo 16v 140hp
- Models: Fiat Abarth Punto Evo
- Engines: 1.4 Multiair Turbo 16v 165cv
- Models: Fiat 500
- Engine: 1.4 16v 102cv multiair
- Engine codes: 955A6.000, 955A2.000, 955A7.000, 940A2.000, 955A8.000
- With instructions included.

Code	Desc.
4770005610	662

## Tensioner bearing Fiat Punto, petrol



Code	Desc.
4770002230	223

## Tool top dead center



- Tool control T.D.C. first piston cylinder for positioning the sensor support plate (static electronic ignition) to use with dial gauge with 10mm stroke engine 1581-16v  $\varnothing$  14x 1.25.
- Fiat Bravo-Brava engine 1581-16v.
- For latest models gr. Fiat  $\varnothing$ 12x1,2.

Code	Desc.	$\varnothing$ x filetto
4770002180	218-14x1,25	14x1,25
4770002182	218-12x1,25	12x1,25

## Centesimal comparator



- Stroke 0-10 mm for use with tool contr. T.D.C.
- Diameter 58 mm

Code	Desc.
4640000200	165

8

## Tool captures flying Fiat 1.8 for engines Gasoline and Diesel



- Engines: 1.8 petrol & diesel 1.6, 1.9, 2.0, 2.4.

Code	Desc.
4770005615	663

## Kit timing gasoline engines Ford (full key lock pulley)



- Models: Ford: Fiesta, Focus, Puma Mazda: 121 Volvo: S40, V50 gasoline
- Engines: 1.2, 1.4, 1.6, 1.7 16V. 1.8 & 2.0 16V belt. Belt & Chain 1.4, 1.6 & 16V.Focus Mazda 121
- Engine codes: FUJA, FUJB, FXJA, FXJB, FYJA, FYJB, F8JA, F8JB, F8JV, M7JA, M7JB, DHA, DHB, DHC, DHD, DHE, DHF, DHG, FHA, FHD, FHE, FHF, L1T, L1V, L1E, L1G, L1H, L1K, L1W, RDA, RDB, RKC, RQB, RQC FXDA / C, FXDB / D, Fyda / C, FYDB / D, FYDH, HWDA.
- With instructions included.

Code	Desc.
4770005620	664

## Kit timing Ford diesel engines: 2.0, 2.2, 2.4 16v Duratorq TDCI

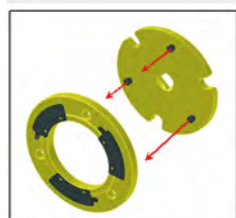

- Models: Focus C-Max, S-Max, Mondeo, Transit, New Galaxy
- Engines: 2.0, 2.2, 2.4 Duratorq TDCI 16V
- Engine codes: FMBA / B, D5BA, ABFA, D3FA, D6BA, HJBA / B, F3FA, D2FA, D4FA, F4FA, FIFA, Dofa, QJBA, QJBB, FXFA, H9FA.
- With instructions included.

Code	Desc.
4770004730	

## Complete kit for the commissioning phase and replacement of the timing belt engine Ford 1.6 Ti-VCT

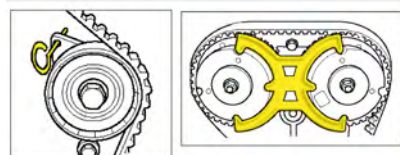

- Models: Fiesta, Focus, C-Max
- Engines: 1.6 TI-VCT, 2.0 TDCI
- Engine codes: HXDA, HXJA, SIDA, G6DA, G6DB, G6DC
- With instructions included.

Code	Desc.
4770005625	665

## Capture tool flywheel Ford engines

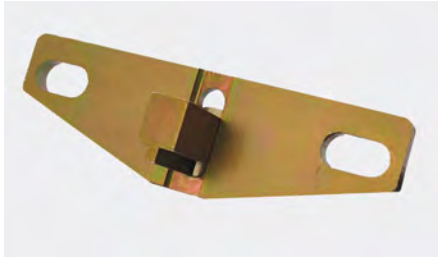

Code	Desc.
4770002940	294

## Pin timing Ford Zetec E



- Timing pulley locking pin for new engines and Ford zetec gasoline.
- Zetec engines and are currently mounted on models 16v Ford Fiesta / Focus / Mondeo petrol.
- For all repair shops.

Code	Desc.
4770002520	252

## Pin timing Ford TDCI



- Timing pulley locking pin for new Ford common rail diesel engines.
- The engines are currently fitted on models Ford Focus / Mondeo / td Galaxy us.
- For all repair shops.

Code	Desc.
4770002530	253 + TD CI

## Complete kit for correct positioning camshafts during operations belt replacement diesel engine Opel 2.0 TDI, DTL, DTH, DTX.

- Models: Opel Vauxhall Astra, Astra Van, Zafira, Vectra, Omega, Sintra, Frontera, Signum Saab: 9-3, 9-5 (98-04)
- Engines: Opel: 2.0 & 2.2 Saab: 2.2 with code: D223L
- Engine codes: X20DTL, X20D.
- With instructions included.

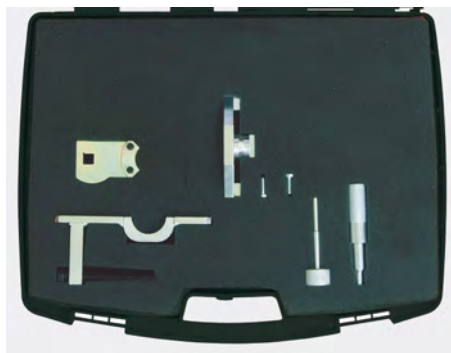

Code	Desc.
4770005635	667

## Tools timings Opel petrol engines

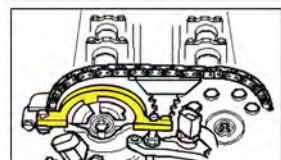

- Models: Corsa, Agila, Astra, Meriva.
- Engine: 1.0 12v., 1.0 16v., 1.2 16v., 1.4 16v. (chain).
- Engine codes: X10XE, Z10XE, Z10XEP, X12XE, Z12XE, Z14XEP, Z12XEP, Z14XEL
- With instructions included.

Code	Desc.
4770005640	668

## Kit for the timing of the engine Opel / Vauxhall from 1.4 up to 2.2 EcoTec 16v DOHC



- Models: Corsa C, Combo, Tigra, Tigra B, Meriva, Astra F, Geh, Speedster / VX220, AEB Zafira, Vectra B EC, Signum, Omega B, Sintra, Frontera AEB.
- Engines: 1.4 16V, 1.6 16V, 1.8 16V, 2.0 16V, 2.2 16V.
- Engine codes: X14XE, Z14XE, X16SEJ, X16XE, X16XEL, Y16XE, Z16XE, Z16YNG, C18XEL, X18XE, X18XE1, Z18XE, Z18XEL, C20SEL, C20XE, X20XE, Z20LEH, Z20LEL, Z20LER, Z20LET, X22SE, X22XE, Y22SE, Y22XE, Z22XE
- With instructions included.

Code	Desc.
4770005645	669

## Locking pin for flywheel engines Opel 1.3 CDI



- Engines: 1.3 cdti
- Pin already in the kit timing MJ 4770002910-291.

Code	Desc.
4770002911	291/O



## Kit timing crankshaft and camshaft engines GM, Opel, Chevrolet 2.0.

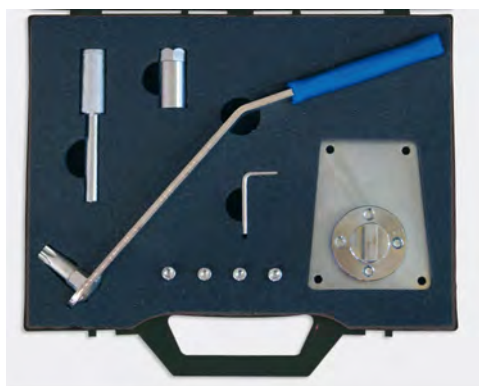

- Models: Opel Antara
- Engines: 2.0 tdcI Daewoo & Chevrolet: Epica, Captiva, Lacetti, Lacetti, Evanda
- Engine: 2.0 D engine VCDII: Z20DMH, Z20DM, RA420, Z20S1
- New updated version that includes the key lock flywheel and crankshaft pulley blocks.
- With instructions included

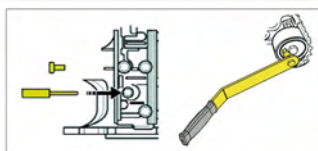

Code	Desc.
4770005655	671

## Kit timing engine Opel 1.6, 1.8 16v gasoline Twinport. (belt)

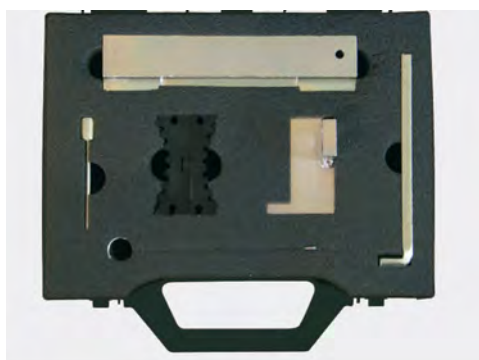

- Models: Corsa-BCD, Agila, GH Astra, Meriva, Zafira-B, Vectra-C, Signum, Insignia.
- Engines: 1.6 16V, 1.8 16V
- Engine codes: Z16XEP, Z16XE1, Z16LET, Z16LER, Z16LEL, Z18XER, A18XER / 2HO - FIAT / ALFAROMEO 939A4.000.
- With instructions included.

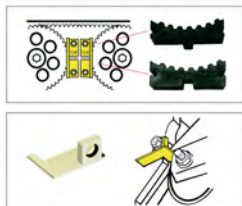

Code	Desc.
4770005650	670

## Tool kit for the timing of the diesel Peugeot



- Models: Citroën Xsara, Xsara Picasso, C2, C3, C4, C5, C8, Xantia, Evasion, Synergie Evasion, Berlingo, Dispatch, Jumpy Dispatch, Relay, Relay Jumper Peugeot: 107, 206, 207, 306, 307, 308, 406, 406 coupe, 407 607, 807, Expert, Partner, Boxer, Ranch Fiat Ulysse, Scudo, Ducato (reference jtd) Volvo S40 / V50 Ford: Focus, Focus C max, Fiesta, Fusion
- Engines: 1.4, 1.6, 2.0, 2.0 d, 2.0 tdcI, 2.2 HDi, 1.4 HDi, 1.6 HDi, 1.6 liter Duratorq TDCi, 1.6 d
- Codes: DV4TD (8HW / 8HX / 8HZ), DV4TED4 (8HV / 8HY), DV6TED4 (9HX / 9HY / 9HZ), DW10T D (RHY), DW10ATED / L3 / L4 (RHS / RHW / RHZ), DW10BTED4 / LB (RHR / RHX), DW10UTD (RHN), DW12ATED (4HW / 4HX), DW12UTED (4HY), D4204T / 2 G6D4, G6DB, G6DC.
- With instructions included.

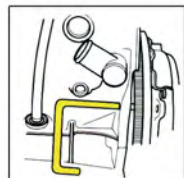

Code	Desc.
4770005665	673

## Complete kit for the timing of the Peugeot petrol engines

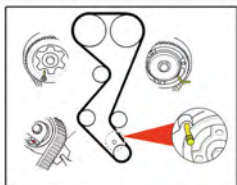

- Models: Citroen: C5, AX, AX, Saxo, C15, BX, ZX, Berlingo, Xsara / Picasso, Visa, Xantia, XM, Synergie, Relay / Jumper, Eevasion / Synergie, Dispatch / Jumpy, C8 Peugeot: 106, 205, 206, 305, 306, 307, 309, Partner, 405, 406 / Coupe, 605, 607, 806, 807, Boxer, Eexpert.
- Engines: 1.0, 1.1, 1.4, 1.6, 1.6 16V, 1.6 GTI, 1.6 18V, 1.8, 1.8 16V, 1.9, 2.0, 2.0 16V, the 2.0T, 2.0 HPI, 2.2 16V
- Engine codes: TU9-1.0, TU1-1.1, TU3-1.4, TU5JP- 1.6 (CDY / CDZ / HDY / KDX / KDY / KFW / KFX / KFZ / NFZ), TU5J4 / L3 (NFX / NFU), XU5 (B1E / B6D), XU9 (D6A / D6B), XU5 (BDY / BDZ / BFZ), XU7 (L6A / LFX / LFZ), XU9 (D6A / D6B / D6D / DDZ / DKZ / DFZ), XU10J2 (RFU / RGX / RGY / RFZ / RFX / RFW / RDC), XU7JP4 (LFY), XU9J4 (D6C), XU10J4 (FRY / RFV / R6E / RFS / RFT).
- With instructions included.

Code	Desc.
4770005670	674

## Kit for the timing of the PSA petrol and diesel engines

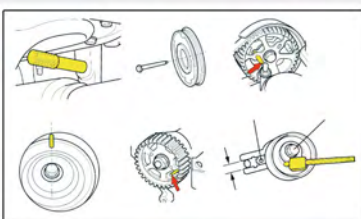
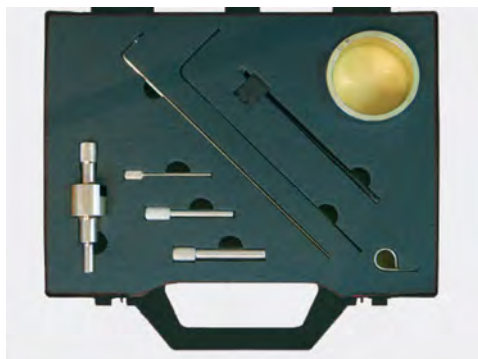

- Models: Ford: Fiesta, Fusion, Focus, Focus Cmax Citroen: Xsara, C2, C3, C4, C5, C8 Evasion Peugeot: 107, 206, 207, 306, 307, 308, Ranch, Expert, 406, 407, 607, 807 Volvo S40 / V50
- Engines: 1.4 -1.6 HDI, 1.6-liter Duratorq TDCi, 1.6 D, 1.8- 2.0 EW.
- Engine codes: DV4TD (8HW / 8HX / 8HZ), DV4TED4 (8HV / 8HY), DV6ATED4 (9HX / 9HY / 9HZ), F6JA, F6JB, F6JC, G8DA, G8DB, EW7J4 (6FZ), EW10J4 (RFN / RFR) EW10J4S (RFK), EW10-CVI (RLZ), EW12 (3FZ), D4164T
- With instructions included.

Code	Desc.
4770004700	330

## Complete kit for the timing and locking the flywheel engine Diesel 2.7 V6 (TDV6)

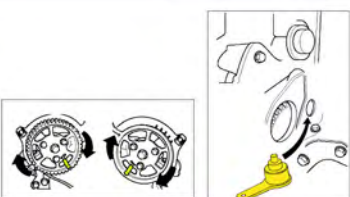

- Models: Land Rover Range Rover Sport, Discovery 3 Jaguar s-type, XJ series CITROEN: Peugeot C6: 4 07 / Coupe, 607
- Engine: 2.7 v6
- Codes engines: 276DT, DT17TED4 (UHZ) (TDV6).
- With instructions included.

Code	Desc.
4770005660	672

## Kit for the timing crankshaft engine Renault 16v gasoline + locking bracket pulley specific distribution for the 1.4 - 1.6 16v

- Models: Renault: Clio, Clio Sport, Megane, Scénic, Laguna, Espace. Nissan Note, Qashqai
- Engines: 1.4-1.616v, 1.816v, 2.016v
- Engine codes: K4J 712/713/750, 700/701/720/724/748 K4M, F4P 760, F4R 700/701/730/740/741/744/780.
- With instructions included.

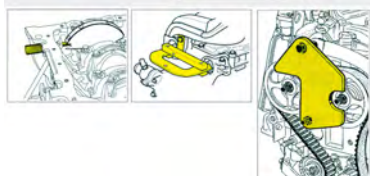

Code	Desc.
4770005675	675

## Kit commissioning phase crankshaft and camshaft, diesel engines Renault

- Models: Renault: Laguna, Espace, Master, Clio, Kangoo Nissan Micra, Interstar, Primastar, Qashqai.
- Engines: 1.5dCi,, 2.2dCi, 2.2 / 2.5DCI.
- Engine codes: G9T710 / 720, G9U, K9K since 2001, G9U 730, G9T 722/750, G9U 720/724/726/750/754.
- With instructions included.

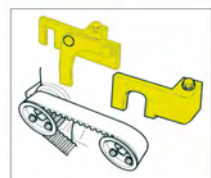
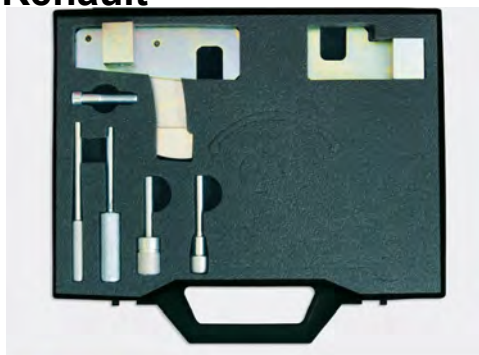

Code	Desc.
4770003030	303

## Kit commissioning phase crankshaft and camshaft, diesel engines Renault

- Modelli: Renault: Mégane/Scénic, Laguna, Trafic, Twingo, Clio, Kangoo. Nissan: Qashqai, Kubistar, Interstar. Volvo: S40 / V40.
- Motori: 1.9 td, 1,9, 1.9 dci, 1.2, 1.2 16V.
- Codici motore: F9Q 732, F9Q 718, F9Q 760, F9Q 732, F9Q 750, F9Q 754,4192Tt3/4, D7F700/701/703/710/730 (1995-06)D4F, 702/704/706/708/712/714/716/730 (2000- 06), D7F726, D4F712, F9Q, 772/774.
- Con istruzioni inserite.



Code	Desc.
4770004710	331

## Kit commissioning phase crankshaft and camshaft, 1.5 diesel engines Renault and Renault petrol

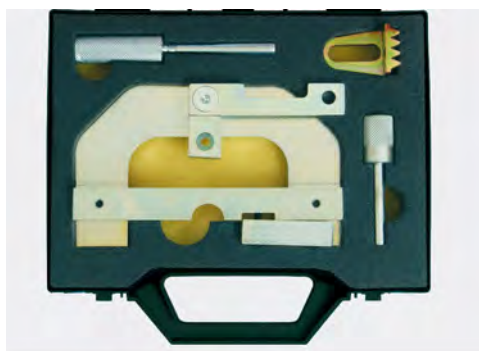

- Models: Renault: Clio, Clio Sport, Megane, Megane Scenic, VelSatis, Avantime, Kangoo, Laguna, Espace. Nissan Micra, Note, Qashqai.
- Engines: fuel: 1.4, 1.5 dCi, 1.6, 1.8, 2.0 16v.
- Engine codes: K4J / K4M, F4P / F4R, K9K since 2001.
- With instructions included.

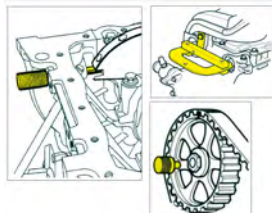

Code	Desc.
4770005680	676

## Tool kit timing crankshaft and camshaft of the new engines Renault 2.0 dCi



- Models: Renault Megane, Scenic, Laguna, Vel satis, Espace, Koleos, Trafic.
- Engine: 2.0 dCi (chain).
- Engine codes: 700, 722, 724, 740, 742, 446, 760, 76, 780, 802, 803, 805, 830, 832, 833.
- Models: Nissan Qashqai, X-Trail, primastar
- Engine: 2.0 dCi (chain)
- Engine codes: M9R 780, 830, 832, 833 this kit is also suitable for engines Vauxhall / Opel
- Aggioranta new version which includes the key lock flywheel and crankshaft pulley.
- With instructions included.

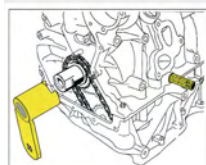

Code	Desc.
4770005690	678

## Tool for the commissioning phase of the pulley camshaft engine Renault petrol



- Models: Clio III, Modus, Scenic II, Grand Scenic II, Laguna II, Kangoo
- Engines: 1.4 & 1.6 16 v.
- Engine codes: K4M - 708/716/730/732/750/752/753/760/761/766/782/800/801/812/813.

Code	Desc.
4770002980	298



## Locking bracket for new Renault gasoline engines



- The bracket is already present in the kit Renault Article 477 00 and 477 00 05 680 05675.

Code	Desc.
4770005685	677

## Locking Plate camshaft sprocket for Renault engines 1.8 & 2.0 t 16 v



- Models: Clio II, Megane, Megane II Megane / Scenic, Scenic / RX4, Scenic / Grand Scenic II, Laguna, Laguna II, Espace / Grand Espace, Espace / Grand Space IV, Traffic II.
- Engine: 1.8 16v & 16v 2.0 t.
- Codes: F4P 720/722/760 F4R 700/701/712/713/714/715/720/722/730/732/740/741/744/746/770/771/776/780/784/786/787 / 790/791/792/794/795 / 796/797/820/830.

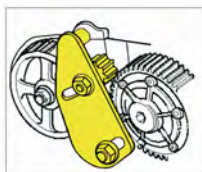

Code	Desc.
4770005720	684

8

## Kit timing engines VW-Audi-Seat-Skoda 1.4 & 1.6 16v. gasoline



- Models: Audi A2 Seat Arosa, Ibiza, Cordoba, Inca, Leon, Toledo Skoda: Fabia, Octavia VW: Lupo, Polo, Beetle, Golf, Bora, Caddy
- Engines: 1.4 & 1.6 16V. SHAFT
- Engine codes: AFH, AFK, AHW, AJV, AKQ, APE, AQQ, ARC, ARR, ATN, AUA, AUB, AUS, AVY, AXP, AZD, BAD, BBY, BBZ, BCA, BCB, BKY.
- With instructions included.

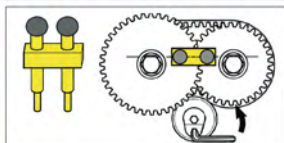

Code	Desc.
4770002740	274



## Kit complete with tools for timing engines VAG Diesel

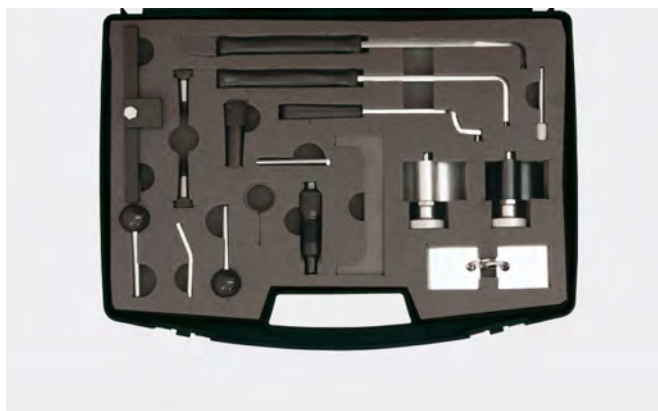

- Models: Audi: 80, A2, A3, A3 Cabrio, A4, A4 Quattro, A5, A5 Coupe / Cabriolet, A6, Quattro A6, TT, Q5 Seat Ibiza, Altea, Altea XL, Arosa, Ibiza / Cordoba, Inca, Leon, Toledo, Aahambra Skosa: Exeo, Fabia, Fabia II, Felicia, Roomster, Octavia, Octavia Tour, Octavia II, Superb, Superb II VW: Lupo, Polo, Polo / Classic, Fox, Golf / Bora, Golf / Plus, Jetta, Jetta III, Eos, Beetle, New Beetle, Scirocco, Tiguan, Passat, Passat CC, Touran, Sharan, Caddy, Wind, Caddy Maxi, Golf Estate, Sharan, Transpoter.
- Engine: 1.2TDI PD, 1.4TDI PD, 1.7SDI, 1.9D / TURBO, 1.9SDI, 1.9TDI, 1.9TDI PD, PD 2.0TDI, 1.6TDI CR, 2.0TDI CR
- Codoci engines: AJM, AMF, ANU, ANY, ARL, ASZ, ATD, ATJ, ATL, AUY, AVB, AVF, AVQ, AWX, AXB, AXC, AXR, AYZ, AZV, BAY, BDK, BGW, BHC, BHP, BHW, BJB, BKC, BKD, BKE, BKP, BLS, BLT, BMA, BMN, BMR, BMS, BMT, BNM, BNV, BPX, BRB, BRM, BRR, BRS, BRU, BSU, BSV, BSW, BTB, BUK, BUY, BUZ, BVA, BVE, BVF, BVG, BVK, BWB, BWV, BX, BXF, AZV, BDJ, BHP, BKD, BLB, BMA, BMM, BMN, BMP, BMR, BNA, BPW, BRC, BRE, BRF, BRT, BSS, BUY, BUZ, BVA, BVE, BVF, BVG, BVH, BWV, CAYA, CAYB, CAYC, CagA, CAGB, CAGC, CAHA, CAHB, CBAA, CBAB, CBAC, CBBA, CBBB, CBDA, CBDB, CBDC, CBEA, CEGA, AHB, AHG, AKU, AKW, 1X, 1Y, AAZ, ABL, AEF, AEY, AGD, AGP, AQM, ASX, ASY, AYQ, 1Z, AFF, AFN, AGR AHF, AHH, AHU, ALE, ALH, ASV, AVG.
- With instructions included.

Code	Desc.
4770005705	681

## Complete kit for timing engines Petrol VW 1.4, 1.4 FSI, 1.6, 1.6 FSi, 1.8, 1.8T, 2.0, 2.0 16v., 2.0 FSi / TFSi (belt)

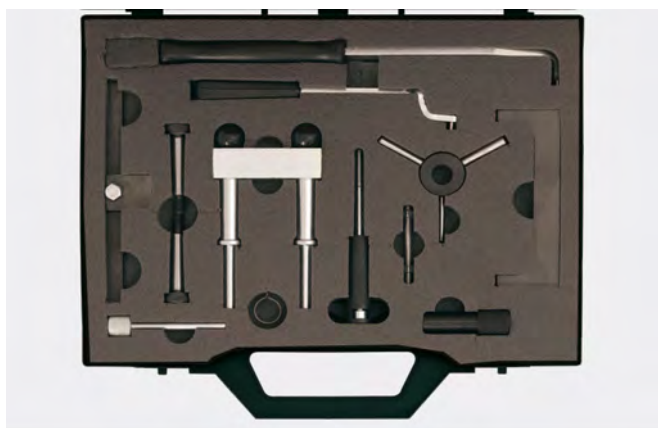

- Models: Audi: 80, A2, A3, S3, A4, A6, Audi TT: 80, A2, A3, S3, A4, A6, TT Seat Altea / XL, Arosa, Ibiza, Cordoba, Inca, Leon, Toledo, Aalhambra Skoda: Fabia, Octavia, Octavia II, Superb VW Polo, Polo / Classic, Beetle, Caddy, Lupo, Golf / Golf Estate, Golf Plus, Bora, Passat, Vento, Jetta, Eos, Touran, Sharan, Transpoter.
- Engines: 1.4 & 1.6 16V. SHAFT, 1.4 FSI, 1.6, 1.6 FSI, 1.8, 1.8 16V, 1.8 T, 2.0 16V, 2.0 FSI / TFSI (belt)
- Codes: AFH, AFK, AHW, AJV, AKQ, APE, AQQ, ARC, ARR, ATN, AUA, AUB, AUS, AVY, AXP, AZD, BAD, BBY, BBZ, BCA, BCB, BKY, April, ADR, AEB, AFY, AGN, AGU, AJH, AJL, AJP, AJQ, AMK, AMU, ANB, APG, APH, APP, APT, APU, APX, APY, AQA, AQX, ARG, ARX, ARY, ARZ, ATC, ATW, AUM, AUQ, AVC, AWC, AWP, AWU, AWV, AYP, BAM, BEA, BFV, BKF, BNU, BVP, BVR, 1F, ABM, ADA, ADP, AEH, AEK, AFT, AHL, AKL, AKS, ALZ, ANA, APF, ARM, AUR, AVU, AYD, BFQ, BFS, BFQ, BGU, BSE, BSF, ABS, ADR, ADZ, AGN, AJP, AMU, APG, APT, APX, ARG, AVV, BFV, BVP, BVR, AGU, AJH, AJL, AJQ, AMK, ANB, APP, APU, APY, AQA, AQX, ARX, ARY, ARZ, AUM, AUQ, AVC, AWC, AWT, AWU, AYP, BAM, ADL, 2E, AAC, AAE, ABK, ABT, ACE, ADY, AEG, AGG, AKT, APK, AQY, ATM, ATU, AWF, AWG, AXA, AZG, AZH, AZJ, AZL, AZM, BEH, ABF, AXW, BGB, BHD, BMB, BPJ, BPY, AXW, BLY, BLR, BVX, BVY, BVZ, AXX, BWA.
- With instructions included.

Code	Desc.
4770005710	682

## Kit commissioning phase motors VW 1.2 L, 3 cil.9v 12v gasoline

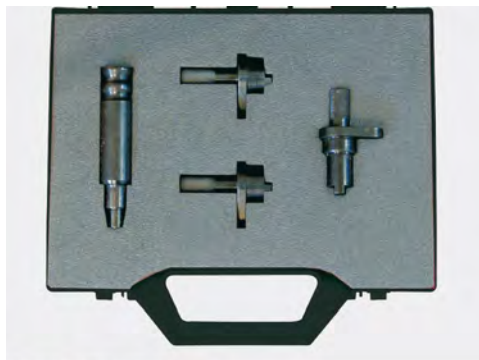

- Models: Volkswagen Fox, Lupo, Polo, Skoda: Fabia Seat Ibiza, Cordoba
- Engines: 1.2 DC 9V-12V 3 cyl.
- Engine codes: AWY, AZQ (55-64 hp) BME.

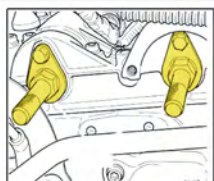

Code	Desc.
4770004680	328

## Kit timing engines VW-Audi-Seat-Skoda 1.2, 1.4, 1.6, 1.9, 2.0 Diesel

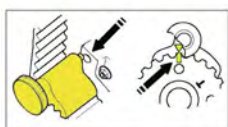

- Included: tool, lock crankshaft pulley round engines TD
- Models: Audi A2, A3, A3 Cabrio, A4, A4 Quattro, A5 Coupe / Cabriolet, A6, A6 Quattro, Q5, TT Seat: Alhambra, Altea, Altea XL, Arosa, Cordoba, Ibiza, Leon, Toledo, Skoda: Exeo, Fabia, Fabia II, Octavia, Octavia Tour, Octavia II, Roomster, Superb, Superb II Volkswagen Beetle, Bora, Caddy, Caddy Maxi, Eos, Fox, Gofl, Golf Plus, Golf Estate, Jetta, Jetta III, Wolf, Passat, Passat CC, Polo, Scirocco, Sharan, Tiguan, Touran, Transporter Ford: Ggalaxy
- Engine: 1.2 TDI PD, 1.4 TDI PD, 1.6 TDI CR, 1.9 TDI PD, 2.0 TDI PD, 2.0 TDI CR
- Engine codes: AJM, AMF, ANU, ANY, ARL, ASZ, ATD, ATJ, ATL, AUY, AVB, AVF, AVQ, AWX, AXB, AXC, AXR, AYZ, AZV, BAY, BDK, BGW, BHC, BHP, BHW, BJB, BKC, BKD, BKE, BKP, BLS, BLT, BMA, BMN, BMR, BMS, BMT, BNM, BNV, BPX, BRB, BRM, BRR, BRS, BRU, BSU, BSV, BSW, BTB, BUK, BUY, BUZ, BVA, BVE, BVF, BVG, BVK, BWB, BWV, BX, BXF, CagA, CAGB, CAGC, CAHA, CAYA, CAYB, CAYC, CBAA, CBAB, CBAC, CBBA, CBBB, CBDA, CBDB, CBDC, CBEA, CEGA.

- Little hand notched left.
- With instructions included.

Code	Desc.
4770005695	679

## Kit timing engines VW-Audi-Seat-Skoda 2.0 TDi PD



- Included: tool, lock crankshaft pulley oval motor BDJ, BLB, BMM, BMP, BNA, BPW, BRC, BRE, BRF, BRT, BSS, BVH.
- Models: Audi A3, A4, A4 Cabrio, A4 Quattro, A6 Seat: Alhambra, Altea / Altea XL, Leon, Toledo, Skoda Octavia, Octavia II, Superb, Superb II Volkswagen Bora, Caddy, Caddy Maxi, Eos, Golf, Golf Estate, Golf Plus, Jetta, Passat, New Beetle, Sharan, Touran, Transporter Ford Galaxy.
- Engine: 2.0 TDi PD
- Engine codes: AZV, BDJ, BHP, BKD, BLB, BMA, BMM, BMN, BMP, BMR, BNA, BPW, BRC, BRE, BRF, BRT, BSS, BUY, BUZ, BVA, BVE, BVF, BVG, BVH, BWV.
- Little hand notched DX.
- With instructions included.

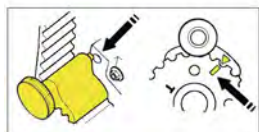

Code	Desc.
4770004720	332

## Kit timing engines VW, Audi, Skoda, gasoline



- Models: Volkswagen Polo, Golf, Golf Plus, Touran, Passat Audi A3 Skoda Octavia
- Engines: 1.4 & 1.6 fsi (chain)
- Engine codes: AXU, BAG, BKG, BLF, BLN, BLP.
- With instructions included.

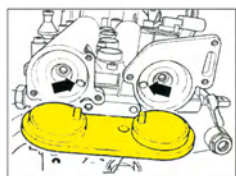

Code	Desc.
4770005700	680

## Key tensioner with long handle for petrol and diesel engines fitted to VW, Audi, Seat, Skoda



Code	Desc.
4770002771	277L

## Key tensioner with short handle for petrol and diesel engines fitted to VW, Audi, Seat, Skoda



Code	Desc.
4770002770	277C

## Key tensioner for gasoline and diesel Volkswagen, Audi, Seat, Skoda



Code	Desc.
4770005715	683



## Maintenance methane



The car market is offering more and more models with CNG supply given the current cost of conventional fuel.

As for diesel-fueled vehicles and gasoline, for CNG vehicles it is good to make the necessary maintenance at regular intervals.

Although to date security reached on the plants to methane it is high and the cylinders are made with special alloys and high strength steels, which is not tested to withstand high temperatures and pressures.

The cylinders are subjected to tests with pressures of 300 atmospheres, clearly in order to make the necessary checks, the bottles should be placed on stands and need special keys to work on the

## Support for CNG cylinders - kit for fixing the cylinders of methane on bench or cart

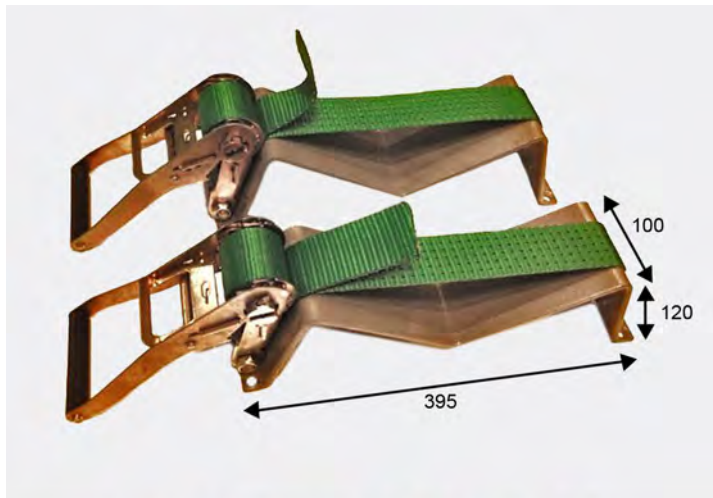

- Kit consists of two robust shaped brackets and straps with ratchet for the anchor securing the cylinder.
- The kit includes the fastening screws from M8x25 + nuts.
- Applicable also on n / s trolley day 4,700,000,100.

Code	Description
4770006280	725 clamping kit CNG cylinders

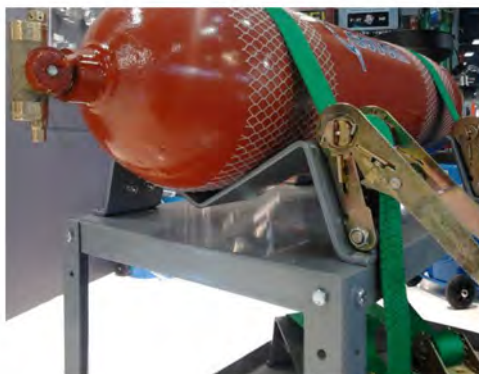

## kit keys for removing the supply valve of the CNG equipment

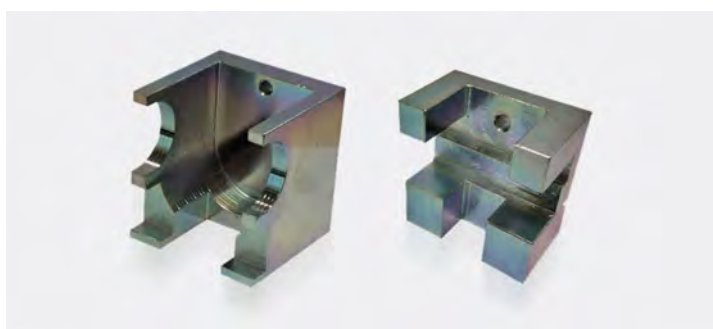

- For Citroen C3 1,4I engines.
- Sized spanner 36mm.
- 2 keys (small tank + big tank).

Code	Description
4770006270	724 NATURAL GAS SUPPLY VALVE KEY KIT CITROEN C3

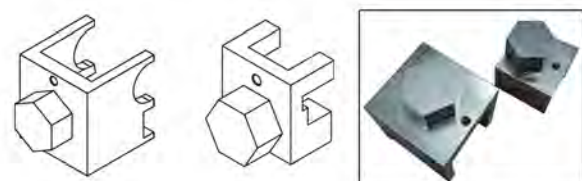



### Key valve power plant to natural gas



- Per Fiat Panda motori 1,2 - Panda Van - Punto e Grande Punto mod.199 - nuovi e vecchi modelli
- Esagono di manovra 36mm

Code	Description
4770006220	719 NATURAL GAS SUPPLY VALVE KEYS PANDA 1.2

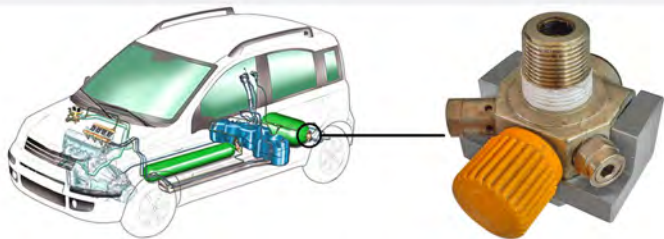

### Kit keys for removing the supply valve of the CNG equipment



- Fiat Multipla (MY-03 and MY-04) and Doblò - Punto mod.188 - Daily - Citroen C3 2013
- Square drive 1 "

Code	Description
4770006230	720 KIT LOCKING GAS TANK

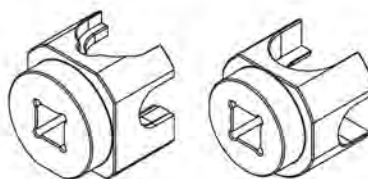
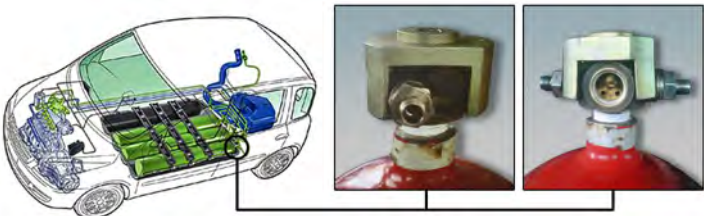

### Key valve power the system to natural gas



- For Mercedes engines NGT - B & E
- Sized spanner 36mm

Code	Description
4770006240	721 KEYS POWER GAS VALVE MERCEDES

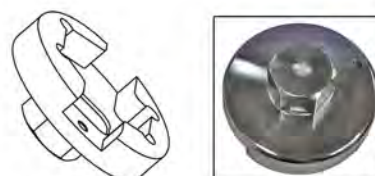
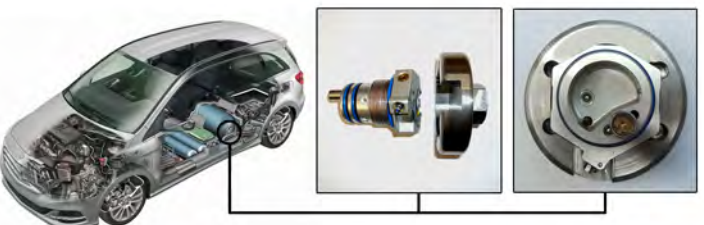

## Kit keys for removing the supply valve of the CNG equipment

- Opel Zafira models old and recent - Combo
- Sized spanner 36mm



Code	Description
4770006250	722 KIT LOCKING GAS TANK

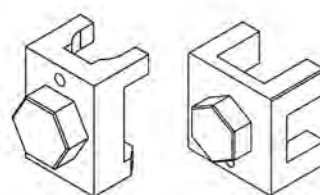
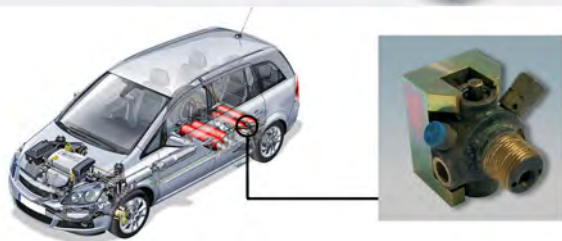

## Key valve power the system to natural gas

- VW Touran 1.4 TSI engines, 2.0 GB - Caddy - Passat
- Sized spanner 36mm



Code	Description
4770006260	723 KEY NATURAL GAS SUPPLY VALVE VW

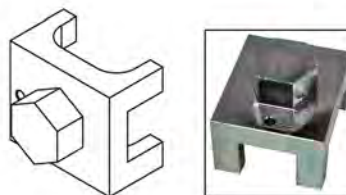
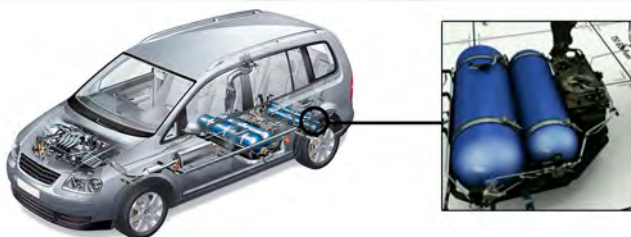

## Digital beamsetters



Code
4700004700

- Tool setter indicated for the perfect centering high and low beam of motorcycles, cars, vans, trucks, construction equipment.
- Alignment system via laser pointer in the upper part of the instrument.
- Optical chamber completely in metal, equipped in its interior of a level for proper alignment during the measurement.
- The optical chamber is adjustable in height by means of a button mounted within a column gridlines.
- Tilt adjustment using headlight wheel at the back of the optical chamber.
- Allows to the digital display for easy reading of the value of the light intensity (LUX).
- The column gridlines can rotate by about 30 ° to align perfectly to the vehicle.
- Equipped with a broad base of three wheels that allows easy transport.

Tecnical Features	
Height mm	174
Profondità mm	670
Larghezza mm	600
Weight	30
Operating min. height (mm)	200
Operating max. height (mm)	150

8

## Parts washing tank Pneumatic



### CHARACTERISTICS

- Bath pneumatic parts washer for washing mechanical parts of motor vehicles and tools in general.
- Suitable for car workshops and industrial vehicles.
- Tank with total capacity of 70 liters, complete with 2 fixed wheels and 2 swivel front rear, certified according to Directive 97/23 / EEC.
- The tank is made of carbon steel, completely coated with epoxy. Equipped with a removable lid and a grid of filtering completely galvanized. The dome jet breaker, placed inside the tank, prevents the accidental spillage of the liquid.
- Complete with safety valve and pressure reducer.
- you can get a continuous flow of cleaning fluid during the cleaning of the mechanical parts.
- Never use flammable or corrosive, we recommend that the use of the liquid parts washing our cod.4110018520 5 Lt cod. 4110018490 25 Lt.

Code	Description
4700004800	2587-TANK parts washer
4700004810	2587P-BRUSH REPLACEMENT
4700004811	2587RG-WHEEL REVOLVING
4700004812	2587RF-WHEEL FIXED
4430045614	599/3 SPIRAL REPLACEMENT
4430049373	920XT Tube level container 8x10 - L46 cm
1760026852	6505-10-1 / 4 super fast connection to 10-1/4"

Tecnical Features	
Pressione max di esercizio (bar)	2
Tank capacity (lt)	40
Vasca (LxHxP) mm	800x200x500
Total height (mm)	1130
Weight kg	52
Capacity	70 lt



## Vaschetta di lavaggio ad ultrasuoni



- Vaschetta di lavaggio per iniettori di motori benzina e diesel e piccoli pezzi metallici, con sistema ad ultrasuoni.
- Indicata per la pulizia e la disincrostazione degli iniettori smontati e piccoli particolari meccanici da ogni tipo di sporco ed incrostazione. Utile in ogni officina meccanica auto-moto-cargo, per pompisti, gasisti, ecc.
- Capacità della vasca: 1300 ml. Alimentazione con corrente alternata 220-240 Volts 50 Hz. Potenza: 50+/-10w. Frequenza degli ultrasuoni: 40 Khz.
- Dimensioni: 228x183x158.
- Fornita con un flacone di pulitore alcalino, disponibile come ricambio, nostro codice 411 00 19900-6305.
- Misure vasca interna: 168x135x55 mm
- Misure cestello: 160x130x50 mm

Code	Desc.
4770006290	726

## Aspires - recovers oil



**ASPIRARE L'OLIO  
A TEMPERATURE  
DI 60°- 80°C**

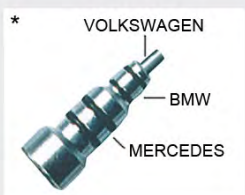

- Combined device pneumatically operated.
- For the recovery of oil.
- It allows you to directly suck the oil from the crankcase of the vehicle through special probes supplied, or to recover, through the tank mounted on the unit, the oil spill.
- Emptying the tank is pneumatically.
- Probes attack round  $\varnothing$  11 mm.
- Plexiglass sizes: diam.200 H350 thick 4 mm.

Code	Desc.	Tank capacity LT	Cap. vis. LT	Bowl capacity LT
4430049370	920	70	10	11

Spare Parts		
Code	Description	Features
4430045279	558TS	Pipe parts display probes with graft
4430045283	558/2 **	Plexiglass + OR + graduated scale adhesive
4430045286	558/26	Vacuum gauge for aspirating oil
4430045287	558/72	Manometer aspirating oil
4430049372	920/S-4X2,5	Flexible probe
4430045273	558/merc	Mercedes probe
4430045277	558/0	Drain pipe
4430055705	1445	Suction pipe
4430049373	920/T	Level hose container
4430055720	1460	Fixed wheel
4700004811	2587RG	Spinning wheel
4430049377	920/G	Grilled spare tank
4430045288	588-43x30x12,5	Tank with grid
4430045281	558/4	Output product group
4430049387	923/10	Ball valve MF 1/4 back
1760026852	6005-10-1/4	Super fast connection to 10-1 / 4 "
4430049368	920 vis	Full viewer



## Probes for oil suction



- For our aspires-recovers oil and aspirates oil without a visor
- 11mm female attack probes
- Standard length of 700 mm
- Length of 1000 mm x commercial and industrial vehicles

Code	Description	Measure
4430049371	920/s Series of sonde connection probes	N ° 6 probes 4 flex + 2 rigid

Spare Parts		
Code	Description	Measure
4430049381	920-5 Flexible probe 5x700	5x3x700
4430049382	920-6 Flexible probe 6x700	6x4x700
4430045276	920-6 Flexible probe 8x700	8x6x700
4430049383	920-6L Flexible probe 6x1000	6x4x1000
4430049384	920-5R metal probe 5x700	5x4x700
4430045271	920-6R metal probe 6x700	6x5x700

## Sucks oil without viewer



- Tank with fully pneumatic operation.
- Aspirated through the probes supplied.
- Particularly suitable for the recovery of exhausted oil tank that can be exploited in full.
- Emptying the tank is pneumatically probes attack round.

Code	Desc.	Tank capacity LT
4430049375	921	24

Spare Parts		
Code	Description	Features
4430045279	558TS	Pipe parts display probes with graft
4430045286	558/26	Vacuum gauge for aspirating oil
4430045287	558/72	Manometer for aspirating oil
4430049371	920/S	Series probes attack round
4430049372	920/S-4X2.5	Flexible probe
4430045273	558/merc	Mercedes probe
4700004813	2588 RF	Fixed wheel
4430049373	920/T	Level hose container 8x10 - W46 cm
1760026852	6505-10-1/4	Fitting s.rapido to 10-1 / 4 "

## Recovers oil



- Tank fitted with tank mounted on telescopic pole.
- For the recovery of used oil through fall.
- Emptying the tank is pneumatically.

Code	Desc.	Tank capacity LT	Bowl capacity LT
4430045282	558/1	70	11

Spare Parts		
Article	Code	Description
drain pipe	4430045277	558/0
fixed wheel	4700004812	2587/RF
Spinning wheel	4700004811	2587/RG
Output product group	4430045281	558/4
Level hose container 8x10 - L46 cm	4430049373	920/T
Super fast connection to 10-1 / 4 "	1760026852	6505-10-1/4



## Universal pneumatic bleeder



**FORNITO CON 2 TANICHE DA LT 1 CON TUBO PER RACCOLTA OLIO FRENI DI SPURGO**

- Apparatus pneumatic operation for bleeding the brakes and clutches.
- The operation takes place via the use of a rubber membrane having the task of not emulsify the oil.
- At the bottom of the device it is now used as a expansion box of air in order to perform multiple tasks with a single charge of purging air.
- Funnel for filling a facilitated and secure.

Code	Desc.	Oil capacity LT
4430049385	923	5

Spare Parts		
Code	Description	Features
4430045561	590/1	Pressure reducer ref. 22
4430045562	590/2	Replacement membrane ref. 15
4430045563	590/3	Fitting with valve ref. 13
4430045564	590/4	Manometer 0-12 ref. 26
4430049386	923/11	Manometer 0-4 ref. 11
4430049387	923/10	Ball valve MF1 / 4 ref. 10
4430045614	599/3	Spiral parts
4430049388	923/36	Funnel parts

## Series plugs brake bleeder



- Complete set of 13 caps for all applications car / truck.
- Caps billet, for a perfect seal.
- With the application table.

Code	Desc.
4430045565	591

## Lista tappi per spurgafreni

MODELLO AUTOVETTURE - CAR MODEL - MODÈLE AUTOMOBILES - MODELL PKW - MODELO AUTOMÓVILES



	TAPPO NR. - CAP NR. - BOUCHON NR. - DECKEL NR. - TAPONES NR.													
	1891.1M	1891.2M	1891.3M	1891.4M	1891.5M	1891.6M	1891.8M	1891.10M	1891.11M	1891.12M	1891.13M	1891.19M	1891.22M	1884
ALFA			X				X			X				
AUDI							X							
AUSTIN			X		X		X						X	
AUTOBIANCHI		X												
BMW							X							X
CITROËN						X	X							
DAF			X				X							
FERRARI							X	X						
FIAT		X	X			X								
FORD			X		X		X							
INNOCENTI			X				X			X			X	
JAGUAR										X				
LAMBORGHINI							X							X
LAFER	X													
LADA														X
LANCIA							X							X
LAND-ROVER					X									X
LEYLAND			X											
MASERATI							X	X						
MITSUBISHI														X
MATRA							X							
MAZDA														X
MERCEDES							X							
NISSAN														X
NSU							X							
OPEL							X					X		
PEUGEOT							X					X		
PORSCHE	X						X							
RENAULT						X	X	X						
ROVER			X											
SAAB							X							
SEAT							X							
SUZUKI														X
TALBOT							X					X		
TOYOTA														X
TRIUMPH					X									
VAUXHALL			X											
VOLKSWAGEN	X						X							
VOLVO							X	X						

MODELLO AUTOCARRI - TRUCK MODEL - MODÈLE CAMIONS - MODELL LKW - MODELO CAMIONES



	TAPPO NR. - CAP NR. - BOUCHON NR. - DECKEL NR. - TAPONES NR.													
	1891.1M	1891.2M	1891.3M	1891.4M	1891.5M	1891.6M	1891.8M	1891.10M	1891.11M	1891.12M	1891.13M	1891.19M	1891.22M	1884
ASTRA														X
BEDFORD			X					X	X	X				
BERLIET					X		X				X	X		
DAF							X						X	
EBRO						X						X		
IAT		X	X			X	X					X		
FORD							X	X					X	
MAGIRUS							X							
MERCEDES							X							
O.M.													X	
PEGASO Comet												X		
RENAULT						X	X				X	X		
SAVIEM						X	X				X	X		
SCANIA							X	X	X					
UNIC						X						X		
VOLVO				X					X					

## Universal cap for brake bleeder



- Universal plug for applications where it is not 'provided the specific stopper.

Code	Desc.
4430045575	593

## Puller pneumatic brake oil



- Product Factory cars and motorcycles, commercial vehicles, service stations and tire shops, body shops, campers and workshops of transformation. Easy operation via connection to the compressed air, no need for electrical connections. Used by a single operator, it allows bleeding, the old and the contemporary recipero oil filling the tank automatically. The small size and ease of use make it popular in the motorcycle sector.
- Constructed of sturdy materials suitable for continuous contact with brake fluids and transparent containers for immediate viewing content.
- The kit includes: brake bleeder gun with 2-liter tank with air connection 1/4 "female pipe connection to the brake calipers 1 m, tank fill pan with universal 1 lt. The brake bleeder Meccanocar and 'suitable only for the extraction of brake fluid.
- Operating temperature: -10C ° + 60 ° C, air consumption: 20 l / min, pressure: 5-11 bar. weight: 9.2 kg.

Code	Desc.
4770004820	341



## Electric brake bleeder 12Vdc



- Tool practical and functional, extremely reliable, it is particularly suitable for car braking systems with ABS and ESP. Tool trolley for practical use and transport.
- It requires only one operator to manage the operation. It does not require compressed air, is connected directly to the battery of the vehicle. To be used exclusively with synthetic oils DOT 3/4/5 / 5.1, the use of mineral oils damages irreparably the internal membranes of the tool making it unusable.
- Supplied with bottle 1lt for oil recovery and adapter cap to 90 °. The adapter cap covers 80% of the assets. For car dealerships and repair shops.
- **Technical features and advantages:**
- 12V DC power input, with core cable mt 3 with connecting clamps to the battery.
- Conservation of the brake fluid in its features intact. Elimination of spongy brake pedal. Operation without compressed air connection
- Recommended for brake systems ABS and ESP. Housing in galvanized steel and brushed stainless steel
- **Work mode:**
- With pressure adjustable from 0.4 to 2.5 bar max 2.7 bar. Pressure gauge pressure indicator (diameter. 62) with glycerin (anti-vibration). Fluid reservoir with a capacity of 10 liters. with sensor of minimum reserves. Mounted on wheels and well balanced, it is very easy to carry. At the rear, a window allows you to control the level of liquid without opening the tank. A single person to manage the operation. Ease of filling of the liquid (mouth of the reservoir diam. 110 mm). Pump with great capacity to transfer the liquid.
- Possibility of supplying during operation. Audible alarm and stop its functioning in case of incorrect connection or liquid below the minimum allowed.
- **Controls:** On / off switch - Pressure regulator
- **Protections:** Thermal protection self-resetting on the pump motor. Fuse on mains power supply.
- Reverse polarity protection with alarm sonoro. Protezione to avoid oil-free operation with audible alarm.
- **Exclusive use with synthetic oils: DOT 3/4/5 / 5.1**
- Optional accessories: \* Universal Plug Adapter (40-85mm). It is used where space permits and where the cap provided

\* TAPPO ADATTATORE UNIVERSALE



Code	Description	Supply
4430056880	1793	12Vcc
4430056885	1793T-PLUG ADAPTER SERIES	RECHANGE
4430056890	1793 TU-PLUG UNIVERSAL 40-85 m	-

## Centered clutches



- Universal tool for centering the clutch plates of all cars.
- The centering is done directly between the disk and the pressure plate which are made integral with the tool itself and re-assembled as one body on the flywheel with the advantage of having a one piece at the time of replacement.
- With the centra clutches universal centering is done without consideration of the hole on the flywheel but is guaranteed the same accuracy.

Code	Description
4770000070	7 TOOL COMPLETE
4770000071	7/1 SMALL PARTS
4770000072	7/2 PARTS MEDIUM
4770000073	7/3 PARTS BIG

## Sander for cylinders



- Apparatus for sanding.
- It fit all drills with flexible attack.
- The sanding arms are self-expandable and interchangeable sanding segments.
- \* 1 To brake cylinders. \* 2 For brake cylinders. \* For 3-cylinder car.

Code	Desc.	Ø	N. arms
4770001380	138	15-45	2*1
4770001400	140	22-50	3*2
4770001520	152	50-175	3*3

Spare Parts			
Code	Description	W. pads mm	Ø
4770001390	139	30	15-45
4770001410	141	30	22-50
4770001530	153	100	50-175

## Battery pole cleaner



- It allows you to remove scale from the poles that is from the battery terminals.
- Handy and functional.

Code	Desc.
4430040810	455



## Mini cleaner for battery poles



- It allows you to remove scale from the poles that is from the battery terminals.
- Handy and functional.
- Compact dimensions.

Code	Desc.
4430040820	456

## Headset for constant velocity joints



- Kit composed of: 1 universal headphone car or cars and vans, 1 tube of grease for specific joints 90 ml, 2 clamps panduit, 1 plastic tie.
- Product suitable for workshops.
- The kit is very practical and allows to have all for replacement surgery headphones without waste of material.
- The material of the headphones is very elastic to facilitate the application in the joint and to have high resistance to oils and fats.
- Headphones, high 13.5 and 15.5 cm allow a wide range of uses.
- Ideal for mounting with our cone headphone cod. 477 00 00650.

Code	Desc.	Ø inf. mm	Ø sup. mm	Leng. mm	Applications
4770004250	316	21	82	135	CAR
4770004400	318	22	106	155	CARS AND VANS

## Headphones for universal joints

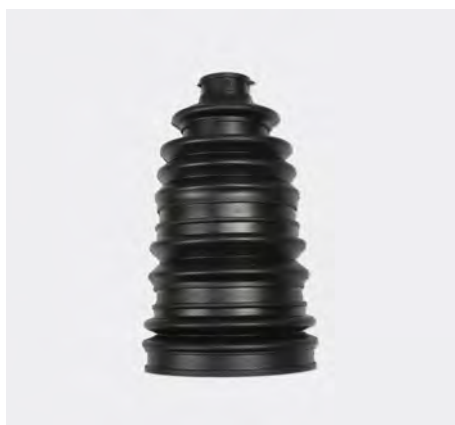

- Headphones for constant velocity joints.
- Made of soft rubber for assembly with the spreader pneumatic our art. 4770005460.
- Universal models.
- AF-Cars and Vans.
- A-Car.

Code	Desc.	Ø inf. mm	Ø sup. mm	Leng. mm	N. Pieces
4770000660	66-AF	22	106	160	1
4770000661	66-A	21	82	125	2

## Pneumatic tool for headphones of constant velocity joints



CUFFIE UNIVERSALI



- Pneumatic tool for headphones of constant velocity joints.
- Utensil pneumatic operation for mounting of the headphones.
- It allows mounting of headphones on the joints without having to get dirty.
- Utensil particularly suitable for auto mechanics.
- During use it is advisable not to exceed the recommended maximum pressure of 8 bar.
- Using headphones that not the universal type involves breaking the headphones themselves as much less elastic.
- With instructions included.
- Supplied with male fitting series Italy.
- Can be used with headphones universal type our articles:

477 00 04250  
477 00 04400  
477 00 00660  
477 00 00661

Code	Desc.
4770005460	649

Technical Features	
Press. Eserc.	4-8bar
Peso dell'attrezzo	2kg
Livello sonoro	-70dB
Diametro max di apertura	110 mm
Ingombro LxHxS	mm465x148x148
Air connection	1/4M

## Cone headphone



- Cone plastic material resistant to oils and grease with steel pin.
- For fitting headphones for constant velocity joints.

Code	Desc.
4770000650	65

## Pliers for spring brakes



- Chrome steel-vanadium.

Code	Desc.	L mm
4430027400	340	210

## Tool for brake spring



- Tool to remove and install the return springs of the brakes on all types of automobiles, also works on the brakes that do not use the fixing pin.
- Spring max 2.5 mm.
- **USE**
- Insert the spring in the tool head and turn the handle to lock it to force the tool to install or to remove it.

Code	Desc.	Ø max filo mm
4770001300	130	2,5

## Tool by extension springs



- Tool by extension springs. usable for the removal and replacement of each type of traction spring: motorcycle exhaust, braking systems, drive handles, etc.
- Suitable for motorcycle workshop, workshops generic, body, etc.
- Practical tool hook designed for the trazione of each type of spring in any position they are.
- The grip at the particular inclination of the hook enable you to catch and reinsert the springs more easily.
- The steel construction makes it highly resistant.
- Length: 150 mm.

Code	Desc.
4770004860	345

## Pneumatic tool for pushing back brake cylinders



- Pneumatic device which allows to retract the brake calipers for the replacement of the pads with left and right rotation.
- It consists of 15 adapters for a wide range of applications.
- Suitable for the rear brakes and the vehicle's front.
- The pneumatic tool allows better application speed with less effort.

Code	Description
4770004100	314 - pneumatic tool for pushing back brake cylinders

Adat.	Applicazioni
0	GENERAL MOTORS
2	CITROEN/XM, Xantia
3	AUDI, FIAT/Alfa Romeo, FORD/Fiesta, ISUZU, HONDA/Concesto, JAGUAR/XJ6, XJ40, BMW/318, 320, 325, 518, 525, 740, 850, M5, MERCEDES Benz/190, 200, 300, 420, 560 series, MITSUBISHI/Colt, NISSAN/Miera, Stanza, Sunny, ROVER/Austin, Metro, 200, 400 series, Maestra, Montego, TOYOTA/Camry, Volvo, VW/Passat, Golf GTI
4	FORD Australia/NZ Telstar, Laser, MAZDA, SAAB 9000, FIAT/Alfa Romeo 164, HONDA/Prelude, CRS 16i, GM/Saturn
5	Adattatore 3/8"
6	NISSAN, PRIMERA, VW/Golf IV
7	AUDI/80, 90, V8+100, Coupe, ROVER/800, SUBARU, FORD/Sierra, Granada, Scorpio, NISSAN/Bluebird, Silvia Turbo, Primera, PEUGEOT/405, TOYOTA/Celica, Corolla, MR2, VW/Golf GTI, Jeta Synchro, Jetta GTI, Passat, Corrado
8	GENERAL MOTORS
9	GENERAL MOTORS
A	RENAULT/R21, Laguna
M	FORD Mondeo
N	SAAB, HONDA
F	OPEL
K	CITROEN
E	NISSAN



## Adapters for brake cylinders



- Specific adapters and indispensable for pushing back the brake cylinders in the process of replacing the pads.
- Suitable for car workshops generic.
- Used in combination pneumatic tool for pushing back the cylinders, our code 4770004100.
- Connector 3/8 "to be used in conjunction with codes 477 00 04101 - 4102 to

Code	Desc.
4770004104	314D



- Specific adapters and indispensable for pushing back the brake cylinders in the process of replacing the pads. Suitable for car workshops generic.
- Used in combination pneumatic tool for pushing back the cylinders, our code 4770004100.
- Adapter with three points for the brake cylinders Iveco Daily and Fiat Ducato 3/8 ".

Code	Desc.
4770004101	314A



- Specific adapters and indispensable for pushing back the brake cylinders in the process of replacing the pads. Suitable for car workshops generic.
- Used in combination pneumatic tool for pushing back the cylinders, our code 4770004100.
- Adapter for the brake cylinders Ford Focus 3/8 ".

Code	Desc.
4770004102	314B



- Specific adapters and indispensable for pushing back the brake cylinders in the process of replacing the pads. suitable for car workshops generic.
- Used in combination with the pneumatic tool for pushing back, our code 4770004100.
- Adapter cylinders BMW Mini 3/8 ".

Code	Desc.
4770004103	314C



- Specific adapters and indispensable for pushing back the brake cylinders in the process of replacing the pads.
- Suitable for car workshops generic.
- Used in combination pneumatic tool for pushing back, our code 4770004100.
- Adapter cylinders BMW Series 1, 3, 5 3/8 ".

Code	Desc.	Model
4770004105	314E	SERIES 1
4770004106	314F	SERIES 3 and 5



- Specific adapter and indispensable for pushing back the brake cylinders in the process of replacing the pads.
- 3-pin adapter for Ford cars and Audi / VW latest models.
- To be used with the n / s arretratore pneumatic art.4770004100
- Applicable directly without adapters

Code	Description	Model
4770004107	314G	FORD-AUDI-VW

8

### Tool adjustable brake calipers models fiat



- This pair of gears allows to retract the brake calipers for the replacement of the pads with left and right rotation.

APPLICAZIONE:

FIAT	
Multipla	1,6 16V
Multipla	1,9 JTD
Multipla	BIPOWER
Multipla	BLUEPOWER
Stylo	1242 16V
Stylo	1596 16V
Stylo	1747 16V
Stylo	1910 JTD
Stylo	2387 20V

Code	Desc.
4770003040	304

N.B.: ATTREZZI INDISPENSABILI PER NON DANNEGGIARE LE PINZE FRENI.

DATI TECNICI:

Pastiglia rotazione pistoncini	35 mm
Interasse spine	26 mm
Rotazione	Dx+Sx
Attacco	Esagono CH19



## Ribe inserts with hole



- Insert Kit short and long profile ribe hole.
- Reinforced inserts for use with screwdrivers.
- Door inserts with square drive 1/2 ".
- Inserts with hexagonal 3/8 ".
- Ribe profile with hole is used on screws put on head, tappets, tensioner, clutch, etc .... New group vehicles Alfa / Fiat and Lancia.
- Factory authorized and not bodies.

Code	Desc.	Length mm	Attachment
4430050660	1015	-	-
4430050665	1015-5x38	38	3/8"
4430050670	1015-6x38	38	3/8"
4430050675	1015-7x38	38	3/8"
4430050680	1015-8x38	38	3/8"
4430050685	1015-10x38	38	3/8"
4430050690	1015-12x38	38	3/8"
4430050692	1015-7x100	100	3/8"
4430050693	1015-8x100	100	3/8"
4430050694	1015-9x100	100	3/8"
4430050695	1015-10x100	100	3/8"
4430050696	1015-12x100	100	3/8"
4430050697	1015-13x100	100	3/8"
4430050700	1015-14x100	100	3/8"
4430044570	501	36	3/8"es-1/2Q

## Deposit "RIBE" 22 PCS



- Measure not included in the KIT Cod. 477 00 02358-235L-12



**COMPOSIZIONE CASSETTA:**

N° 3 BUSSOLE ATT. 1/2:  
 M6x250 PER COPPA OLIO FIAT/LANCIA/ALFA ROMEO  
 M7x250 PER COPPA OLIO FIAT/LANCIA/ALFA ROMEO  
 M8x250 PER COPPA OLIO FIAT/LANCIA/ALFA ROMEO

N° 6 CHIAVI RIBE A LATO CORTO:  
 M5x170 FRIZIONE PUNTO-COPERCHIO PUNTERIE  
 M6x170 FRIZIONE PUNTO-COPPE OLIO  
 M7x170 COPERCHIO VALVOLE  
 M8x170 COPERCHIO PULEGGIA MAREA  
 M9x170 BULLONI TESTATE GRUPPO FIAT  
 M10x170 PASSARUOTA FIAT

N° 13 BUSSOLE ATT. 1/4 DA M4A M13 PROFILO "SAFRANE" N.B. IL PROFILO SAFRANE (esagonale) CONSENTE LA PRESA SICURA DEL PROFILO RIBE MASCHIO  
 ESAGONALE 4.5 = RIBE 5  
 ESAGONALE 5.5 = RIBE 6  
 ESAGONALE 7 = RIBE 8  
 ESAGONALE 9 = RIBE 9  
 ESAGONALE 10 = RIBE 10

IL PROFILO SAFRANE INOLTRE È PRESENTE SU ALCUNI COMPONENTI DI CARROZZERIA E PANNELLATURA INTERNA DI VETTURE GIAPPONESI.

Code	Desc.
4770002350	235
4770002358	235L-12



## Deposit inserts "RIBE"



- Deposit inserts profile RIBE length 38mm and 100mm.
- The various measures to m5 m14 are employed by Fiat Group - Alfa Lancia bolts head / engine oil pan, valve cover and so on.
- The particular strength of the inserts and the door inserts with square 1/2 "it can be used with the impact wrench.
- For machine shops - elettrauto - etc.
- Supplied with 3/8 inserts.

CONTENUTO CASSETTA ATTACCO 3/8"

CODICE	DESC. MIS. mm	Attacco
477 00 05500	653 - 5x38	3/8"
477 00 05505	653 - 6x38	3/8"
477 00 05510	653 - 7x38	3/8"
477 00 05515	653 - 8x38	3/8"
477 00 05520	653 - 10x38	3/8"
477 00 05525	653 - 12x38	3/8"
477 00 05530	653 - 7x100	3/8"
477 00 05535	653 - 8x100	3/8"
477 00 05540	653 - 9x100	3/8"
477 00 05545	653 - 10x100	3/8"
477 00 05550	653 - 12x100	3/8"
477 00 05555	653 - 13x100	3/8"
477 00 05560	653 - 14x100	3/8"
443 00 44570	501	3/8" ES-1/2Q.



Code	Desc.
4770002330	233

8

## Parts box inserts Ribe with 5/16 attack



Code	Desc. / Meas. mm	Attachment
4770002331	233 - 5x38	5/16"
4770002332	233 - 6x38	5/16"
4770002333	233 - 7x38	5/16"
4770002334	233 - 8x38	5/16"
4770002335	233 - 10x38	5/16"
4770002336	233 - 12x38	5/16"
4770002342	233 - 7x100	5/16"
4770002343	233 - 8x100	5/16"
4770002344	233 - 9x100	5/16"
4770002345	233 - 10x100	5/16"
4770002346	233 - 12x100	5/16"
4770002347	233 - 13x100	5/16"
4770002348	233 - 14x100	5/16"
4430046908	764	5/16" ES-1/2Q.

## Key dismantling oil pan



- Special key profile "ribe".
- Specification for mounting / dismantling screws fixing the oil sump.
- Cars for Fiat, Lancia, Alfa Romeo.
- Sized spanner M 11.

Code	Desc.	Measure	L mm	Photo
4770001580	158	M 7	200	1
4770001590	159	M 8	250	2

## Key caps float tank



- Adjustable wrench, allows the disassembly and assembly of tank caps with dipstick on all types of automobiles.
- With the adjustable arms allows a secure grip on more measures of plugs.
- Steel arms adjustable knurled adjustment ring, sized spanner mis. 24.
- Suitable for all workshops and elettrauto.
- Particularly suitable for Renault, Peugeot, Citroen, Opel, VW / Audi, Alfa, etc..

Code	Desc.	For caps Ø
4770001700	170	75 - 120
4770001701	170/1	120 - 160

## Pliers spark plug with thermal insulation



- Beaks specially shaped mounting and removing caps with thermal insulation.

Code	Desc.
4430046014	627

## Spark plug pliers



- Special pliers extra long, prehensile grip with tubes from 45 mm.
- Special to mount and dismount spark plug caps housed deep (16-valve engines).
- Particularly useful when the engine is hot.
- Universal use.

Code	Desc.	L mm
4770001740	174	250

## Caliper seal 16 valve engines



- Forceps extraction rubber seal mounted on the stem of the valves on 16-20 24-valve.
- Jaws temperate.

Code	Desc.
4770001500	150

8

## Pliers for cable ties VW-Audi



- Pliers with jaws revolving facility for a cable mounted on sleeves cars VW-Audi.

Code	Desc.	L mm
4770000221	22/1	205



## Clamp with remote control



- Pliers with remote control (via cable) for the assembly and disassembly of all the elastic bands.
- For clamps with diameter 18 to 54 mm.
- It allows to work - thanks to the cable - even in inaccessible places (see bottom hose of the radiator).
- It also allows you to lock the clamp in the open position - to finish the job - and then replace the hose clamp on without ever removing it from the caliper.
- Suitable for all car models.

Code	Desc.	Range
4770001710	171	18-54 mm

## Caliper with remote maxi



- For use of elastic bands to measure 7 to 60mm.
- Allows the opening and locking the clamp open thanks to the locking system incorporated.
- The cable allows you to reach space without the straps sleeves positioned low in the engine compartment.
- Thanks to the high range (7-60mm) allows use of cable ties is small (car) that the big bands mounted on the sleeves of SUVs and light commercial vehicles.
- Indispensable tool for body builders and mechanics.

Code	Desc.	Range
4770001712	171/2	7-60 mm

## Special clamp for fittings of the fuel filter



- Special pliers to disconnect the connections of the fuel filter mounted on motors multijet Fiat group.
- Specific tool for car workshops.
- It allows to drop in a simple, safe and quick fittings plastic fuel filter, both those located in inaccessible places (eg commercial vehicles) and those more worn, that is very hard, for which it is difficult to remove them manually or with the generic use of tools.
- Unlock easily with no damage to the pipe.
- Made of high-strength steel for a long life.

Code	Desc.
4770005000	348



## Jointed gripper disengages water pipes and fuel



- Pliers to unhook the tubes pass water and fuel inside the engine.
- Product repair and body shops.
- The head opens up to 180° of the clamp allows to reach the most hidden parts of the motor with great time savings and efficiency in the work.
- The jaws of the pliers are very durable and do not allow to cut the tubes on which they work.
- Maximum length of pliers: 23.5 cm, maximum length of levers: 9.5 cm.

Code	Desc.
4770004740	334

## Clamp fittings for gasoline



- Gripper with special profile.
- It allows easy removal of the fuel hoses with quick coupling in the fuel filter (NB fuel filters are no longer fixed with clamps, the new cars have assembled these quick connectors).
- Inserting the two lugs on the clamp mounted in the recesses of the quick connector unlocks the tube easily without causing any damage.
- Cars for Fiat, Opel etc.

Code	Desc.
4770001690	169

## Clamp fittings for gasoline



- Caliper with a special profile to disconnect the quick connect couplings mounted on the fuel pipe during filter replacement.
- Beaks bent at 90°.
- Essential to disconnect the hose on the cars of the Fiat group; launches; Alfa Romeo; VW; Audi 98.

Code	Desc.
4770002030	203

## Clamping grippers for pipes



- Pliers with automatic adjustment for bottleneck sleeves and water pipes and gasoline.
- Made of high strength plastic.

Code	Desc.	Width cut mm	For pipes Ø mm
4770002080	208 - 15	20	8÷15
4770002081	208 - 28	37	15÷28
4770002082	208 - 65	76	26÷65

## Dipstick engine oil VW AUDI



- Adjustable metal rod to measure the engine oil level in the engines of VW Audi group with presonda.
- The auction once set according to the table in each room, depending on the type of engine, allows to carry out the control of the engine oil level.
- Indispensable tool for workshops, service stations, garages.
- These cars have the electronic control of the oil level on the display, when you make an oil change or replacement of the sensor, the level must be tested in this auction and the verified value compared with that reported by the display.

Code	Desc.	Length mm
4770005470	650	620

Motore	Valore da impostare sull'anello di impostazione	Livello olio minimo sulla scala in basso	Livello olio massimo sulla scala in basso
2.0 TDI	46	0	24
2.7 TDI	32	0	16
3.0 TDI	32	0	16
2.0 TFSI	39	0	24
2.8 TFSI	39	0	24
3.0 TFSI	132	0	13
3.2 TFSI	132	0	13



## Bushings disassembles-injectors



- Bushings with special slot.
- Polygonal version for cars.
- Hexagonal version for heavy trucks.
- The special slot allows Disassembling without any problem.
- Hexagonal version for heavy duty.

Code	Desc.	Attachment	Execution	Applications
4770002290	229-22P	1/2	POLYGONAL	VW Polo
4770002291	229-22E	1/2	HEXAGON	VW Polo
4770002294	229-28E	1/2	HEXAGON	Bravo/a-Alfa 164-145-146 engines VM-Scania

## Cutters for the cleaning of the seats of injectors



- Kit consists of 4 mills for cleaning the inside of the premises of common rail injectors type Bosch / Delphi.
- Suitable for car workshops generic, for those who carry out repair and overhaul of pumps and injectors.
- Indispensable to clean and wipe the seats of the injectors mounted on modern common rail diesel engines, during the operations of replacement or repair of the injectors.
- Removes residual calamine deposited in the housings of the injectors, eliminating the risk of malfunction of the engine (bad combustion), increasing the yield.
- No risk of damaging the cylinder head of the engine during the cleaning operation.
- Supplied a handle "T" resistant steel for added convenience during operation and an extension cord to reach the farthest points.
- Equipment provided in handy case.

Code	Description	Diameters	Applications	Quantity
4770005340	636- kit cutters for cleaning offices injectors	-	-	-
4770005341	636 / 1- flat cutter	15/19 MM	Universal	1
4770005342	636 / 2- flat cutter	17/17 MM	Injectors Bosch / Delphi (BMW, PSA, Renault, Ford)	1
4770005343	636/3- flat cutter	17/19 MM	Bosch injectors (Mercedes crd)	1
4770005344	636/4- conical cutter	17/21 MM	Fiat / Iveco	1
4770005345	636/5- "T" handle	/	/	1
4770005346	636 / 6- universal pin port cutters	/	/	1

## Bushing lambda probe model long



- Allen key with groove for the passage of the cable.
- Allows the assembly and disassembly of the lambda probe is not heated.
- For most of the cars or national import.

Code	Desc.	Measure mm	Attachment	Leng. mm
4770000950	95	22	1/2"	90

## Bushing lambda probe short model



- Bush for assembly / disassembly lambda probe for all those motors that can not use the long type for spaces required.
- Mis 22 for all European cars.
- Mis 20 for Japanese cars.
- Double square drive for greater maneuverability.

Code	Desc.	Measure mm	Attachment
4770001230	123-22	22	1/2
4770001232	123-20	20	3/8

## Keys for ignition plugs



- Socket wrench jointed for assembly and disassembly spark plugs mounted on 1.3 and 1.9 Multijet engines.
- For all models of Fiat Alfa Lancia Opel Saab.
- With square 3/8".
- For workshops and electricians.

Code	Desc.	Measure "	Attachment
4770001838	184-5/16	5/16	3/8
4770001837	184-8	8	3/8

## Bushing plugs HDI



- Open wrench for assembly and disassembly spark plugs mounted on HDI engines mounted on Phedra, Ulisse and Scudo.
- With sized spanner 10mm.
- The compass is an open type because of these models of cars you can not disconnect the plugs from the control unit, then you must first remove the spark plug and then unplug it. For all other plugs 9mm except those fitted to the engines in question (HDI), there is no problem and then you can operate safely.
- For workshops and electricians.

Code	Desc.	Measure mm	Attachment <i>esag.</i>
4770001839	184-9	9	10

## Special wrench for glow plugs



- Socket wrench articulated 3/8".
- The hex 3 check balls hold the glow plugs during assembly / disassembly.
- Hexagon 10 meters for all new plugs.
- Hexagon 12 m for all the old plugs.

Code	Desc.	Measure mm
4770001840	184 - 10	10
4770000490	49 - 12	12

8

## Special wrench for BOSCH alternators



- Indispensable tool for disassembly and repair of alternators ventilated latest generation of series "Bosch" pulley with free wheel.
- Without this tool it is impossible to remove the drive side pulley.
- For cars from 1995: Audi-BMW-Ford Mercedes-Skoda-VW.
- To be used with the compass XZN M8.

Code	Desc.	Wrench
4770002120	212	17

## Key alternator Fiat Grande Punto and Bravo



- Special wrench with square 3/8".
- Essential for removing the pulley alternators fiat punto and good.
- Technical product and specific use with alternator removed from its housing.
- For workshops and elettrauto.

Code	Description
4770004500	319 - KEY ALTERNATOR G.PUNTO / BRAVO



## Key Set belt tensioners 5 Pieces



- Series ring spanners for pulleys distribution, subsidiary bodies and nuts tensioner.
- Suitable for general car repair shops.
- Allow the effective and quick clamping of belts of type v-ribbed or toothed belts during the replacement, or adjustment of the same.
- The flat shape and thin, combined with the length of the keys, makes them ideal for operation in confined spaces, difficult to reach with the use of the normal keys.
- Treated steel, high strength and non-slip rubber handle.
- Set consists of 5 keys of length 46 cm.



Code	Desc.	Content
4770005075	375	set 5 Keys Polygon: 13-15-16-17-19 mm

Spare Parts	
Code	Description / Measure mm
4770005080	375 - 13
4770005085	375 - 15
4770005086	375 - 16
4770005087	375 - 17
4770005089	375 - 19

## 90° angle screwdriver extra long



- Screwdriver 90° suitable for adjusting carburetors for motorcycles and scooters. It can also be used for generic operations in a very small space.
- Product particularly suitable for motorcycle workshop, workshops generic body.
- The length of the screwdriver united to his particular angle makes it indispensable for adjusting the carburetors are located in less accessible places.
- The aluminum construction makes the product lightweight and easy to use.
- The interchangeable heads Bevel run on ball bearings guarantee excellent smoothness.
- Providing additional removable knob that allows a better grip of the screwdriver and consequently greater accuracy on the vine.
- Featuring 5 inserts flat blade, width 5 mm and length 4, 10, 19, 42, 78 mm and 2 inserts cross from Phillips 2x18 mm and 2x40 mm, making it suitable for other types of operations.
- Supplied in a practical case (size: 500l x 120p x 60h mm).

Code	Desc.	Width x length
4770004850	344	-
4770004851	344/4	5X4 mm
4770004852	344/10	5X10 mm
4770004853	344/19	5X19 mm
4770004854	344/42	5X42 mm
4770004855	344/78	5X78 mm
4770004856	344PH/18	2X18 mm
4770004857	344PH/40	2X40 mm



## Kit unravels chains and rivets



- Kits able to laddering and retort all types of transmission chains with sizes up to 530.
- Particularly suitable for motorcycle workshop.
- It allows users quick and easy disassembly / reassembly of the chain pin without having to use the hammer, with the risk of damaging the chain.
- The equipment is highly resistant hardened steel nitrided.
- The tool contains a nut on one side which allows to intervene with greater force by the use of a key.
- Complete with pins for extraction, diameter 3, 4, 5 mm, and for the riveting.

Code	Desc.
4770004840	343

Spare Parts	
Code	Description
4770004841	343/1 SPARE TIP 3 MM
4770004842	343/2 SPARE TIP 4 MM
4770004843	343/3 SPARE TIP 5 MM
4770004844	343 / 4.1 MOUNTING BASE 4.1
4770004845	343/4.2 MOUNTING BASE 4.2
4770004846	343/4.3 MOUNTING BASE 4.3

8

## Clamp for motorcycle chain



- Practical tool to be used whenever there is need to replace a motorcycle chain.
- Used in conjunction with the kit unravels chains and rivets n / s art.477 00 04840.
- For motorcycle chain measure 428,430,520,525,530.
- Thanks to the shape of the arms and the ability to adjust, you can keep close the two sides of the chain while reassembling the false mesh without the problem that the chain can move.



Code	Desc.
4770005490	652

## Cleaner hollow piston



- Universal tool for quick cleaning of the hollow piston.
- The powerful spiral spring holds the cutting tool in the slot with extreme ease and free from all deposits.
- Provided with two cleaning tools for the various thicknesses.
- For piston  $\varnothing$  51 to  $\varnothing$  127 mm.

Code	Desc.
4770000050	5

## Try sparks, candle cable tester



- Practical tool for the verification of the spark plug wires on.

Code	Desc.
4770000870	87

## Series 5 levers P.T.F.E. in plastic



- Set consists of 5 levers PTFE.
- The particular form of the levers lets you remove the plastic parts such as buttons, moldings, panels, etc.
- The PTFE allows, compared to other materials, to decrease the risk of producing scratches on paint.

Code	Description
4770004200	315 - Set 5 levers for bodywork P.T.F.E.

### Set wedges and levers plastic



- Set of four wedges in plastic anti-scratch and anti-wear material, various shapes and sizes, useful for lifting, disassemble, detach any kind of special car bodies and car interiors, even the most delicate.
- Can be used by the body, but also by mechanical, electrician, processing workshops, and in the automotive, motorcycle and heavy vehicle sectors.
- The set includes two wedges 20 cm long 3 and 6 centimeters wide, a smooth rounded wedge length of 13 cm and a 27 cm long lever wedge on the one hand and with the other slot for the detachment of buttons and rivets in plastic.

Code	Description
4770006560	743

### Cuneo Teflon for moldings



- Teflon wedge designed to fit the moldings of car.
- Suitable as a lever for positioning during assembly of doors, hoods and doors.
- Being teflon, resets, compared with other tools the risk of damage paints for rubbing.

Code	Desc.
4770001460	146

8

### Dismantling tool handles



- Tool to extract handle catch windows lifter before dismantling.
- Galvanized steel.

Code	Desc.
4430000050	27

## Special tool for handles



- Tool for removing door handles, front and rear of the new VW vehicles.
- Indispensable tool for mechanics and body shops.
- The special shape allows you to go to remove the handles without damaging the bodywork.
- Essential models: Golf VI, Fox, Tiguan, Passat.

Code	Description	Length mm	Weight gr.
4770005450	648-Tool for handles	240	70

## Hammer for bodywork - 2 round heads



- Forged steel.
- Wooden handle.
- 2 round heads.

Code	Desc.	Testa Piana	Testa convessa
4430035200	398	ø mm 33	ø mm 36

## Hammer for bodywork - with round and pointy

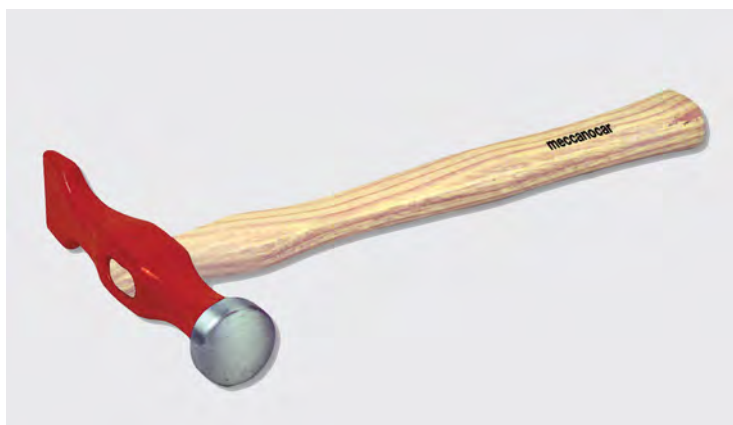

- Forged steel.
- Wooden handle.
- 2 heads: 1 round - 1 pen.

Code	Desc.	Testa tonda	Testa penna
4430035300	399	ø mm 35	mm 38



### Hammer for bodywork - with round rounded and square



- Forged steel.
- Wooden handle.
- 2 heads: 1 round domed - 1 square.

Code	Desc.	Testa bombata	Testa quadra
4430035400	400	ø mm 30	mm 30

### Hammer for bodywork



- Forged steel.
- Wooden handle.
- 2 heads: 1 knurled round - 1 square smooth.

Code	Desc.	Testa tonda	Testa quadra
4430035500	401	ø mm 45	mm 40

8

### Hammer for bodywork

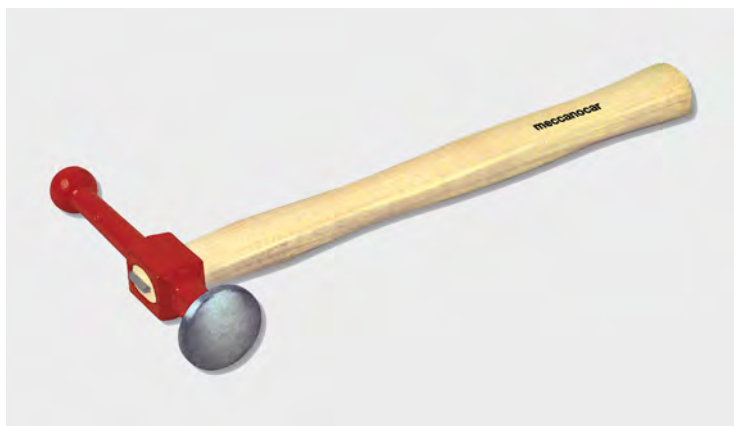

- Forged steel.
- Wooden handle.
- 2 heads: 1 round flat - 1 ball.

Code	Desc.	Testa tonda	Testa sfera
4430035600	402	ø mm 40	ø mm 20

### Hammer for bodywork - round head and rounded tip.

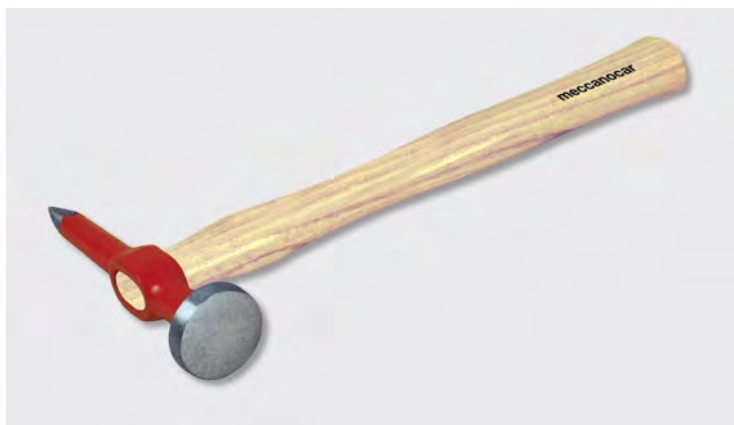

- Forged steel.
- Wooden handle.
- 2 heads: 1 round rounded - tip 1.

Code	Desc.	Testa tonda bombata	Testa punta
4430035700	403	ø mm 40	mm 135

## Hammer for bodywork - round head and rounded pen



- Forged steel.
- Wooden handle.
- 2 heads: 1 round domed - 1 pen.

Code	Desc.	Testa tonda <i>bombata</i>	Testa penna
4430035800	404	ø mm 40	mm 20

## Dowel bodywork



- Type rail.

Code	Desc.	H <i>mm</i>	Leng. <i>mm</i>	Width <i>mm</i>
4430036000	406	63	70	58

## Dowel bodywork



- Type 2 heads: 1 flat head - one convex head.

Code	Desc.	H <i>mm</i>	Ø testa mm
4430036100	407	58	57

## Dowel bodywork



- Type half-round.

Code	Desc.	H <i>mm</i>	Length <i>mm</i>	Width <i>mm</i>
4430036200	408	30	84	62

## Dowel bodywork



- Flat-type long-rounded.

Code	Desc.	H <i>mm</i>	Leng. <i>mm</i>	Width <i>mm</i>
4430036300	409	28	110	60

### Dowel bodywork

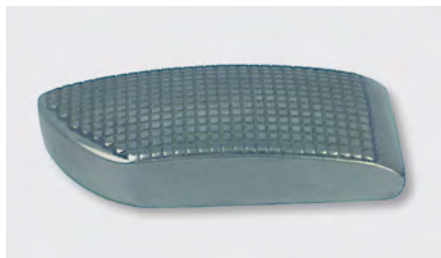

- Convex type.
- Face convex hull.

Code	Desc.	H mm	Length mm	Width mm
4430036400	410	28	120	58

### Dowel bodywork

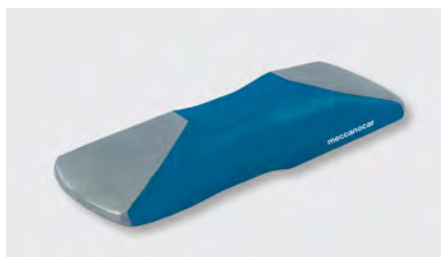

- Butterfly type.

Code	Desc.	H mm	Leng. mm	Width mm
4430036500	411	44	122	47

### Dowel bodywork

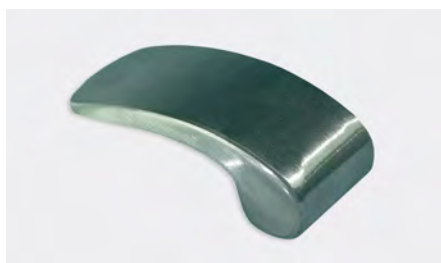

- Type a comma running heavy.

Code	Desc.	H mm	Length mm	Width mm
4430036800	414	45	145	63

8

### Piece three-headed



- Three in one.
- Dowel tip, piece Round Head d. 30 mm, flat curved.
- Thanks to the central ring the dowel "3 in 1" is usable with one hand and in places, unthinkable for a normal gusset much less for a hammer by body.

Code	Desc.	Weight gr.
4430050880	1026	300

### Coachbuilder levers



- Fold sheets.
- With seal leather.

Code	Desc.	Length mm
4430037500	421	420

### levers coachbuilders



- Lever bent trowel.

Code	Desc.	Length mm
4430037600	422	290 x 30

## levers coachbuilders



- Lever bent spoon.

Code	Desc.	Length mm
4430037700	423	310 x 55

## levers coachbuilders



- Lever slightly curved spoon.

Code	Desc.	Length mm
4430037800	424	365 x 60

## Levers coachbuilders



- Lever with two sides crankshafts.

Code	Desc.	Leng. mm
4430037900	425	400 x 60

## Levers coachbuilders



- Lever with two sides elbow bent.

Code	Desc.	Length mm
4430038000	426	450 x 60

## Adjustable door files



- Kits of files flexible 350mm (14 ").

Code	Desc.
4430040400	449

## File for body shops



- For art. 443 00 40400-449.

Code	Desc.	Taglio
4430040520	450TG	BIG

## Set cuscinetti gonfiabili apri-portiera



- Un semplice gonfiaggio manuale permette al cuscinetto gonfiabile meccanocar di esercitare una forte pressione distribuita, e quindi assolutamente non dannosa, sulle superfici a cui viene a contatto.
- Il cuscinetto gonfiabile meccanocar costituito da materiale sintetico rinforzato e' un prodotto testato di assoluta qualita'.
- Il set costituito da 3 pezzi di diversa misura permette un campo di utilizzo sempre diverso a seconda delle esigenze incontrate.
- Idoneo per svariate applicazioni, e' un prodotto veloce e semplice da utilizzare. permette di lavorare con entrambe le mani libere.
- **CARATTERISTICHE TECNICHE:**
- Pressione standard: 100kg per pezzo.
- Spessore minimo 2 mm.
- Spessore massimo in esercizio: 80 mm.
- Dimensioni in mm: 16x16, 6x19, 4x18.



**SET 3 CUSCINETTI  
DI DIVERSE  
DIMENSIONI**

**EVITA DEFORMAZIONI  
PERMANENTI SULLE  
PORTIERE E  
FORMAZIONI DI GRAFFI  
ACCIDENTALI.**

Code	Desc.
4770003090	309

### Vari utilizzi:



Scegliere la misura piu' idonea di cuscinetto e inserirlo tra il vetro e la guarnizione di gomma. Gonfiando il cuscinetto si esercita una forte pressione distribuita allo scopo di creare lo spazio necessario per l'inserimento degli strumenti.



Le diverse dimensioni dei cuscinetti permettono sempre di ottimizzare lo spazio necessario all'inserimento del prodotto. L'utilizzo dei cuscinetti permette l'apertura della portiera senza arrecare danni gravosi alla struttura.

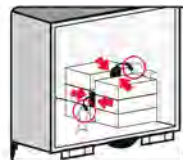
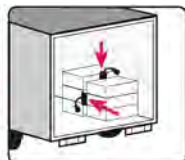

Utilizzare il set di cuscinetti permette inoltre una facile e pratica protezione dei carichi a contatto tra loro.

8

## Lever disassembly buttons



- Lever handle for removal without damaging the plastic buttons.

Code	Desc.
4430044670	507

## Clamp off buttons



- Ideal for quick disassembly of the plastic buttons.
- The lever system prevents loss of coatings.

Code	Desc.
4430045120	540



## Detach glass automatic



- Complete system with manual operation for disassembly by a single operator of the vehicle glazing panels.
- Suitable for specialists in the field of repair of cars and vans: bodies, centers windshield replacement.
- The complete kit contains all the necessary for cutting the sealant and detachment of the glass by a single person, in a simple and safe, without the need to disassemble the internal parts, without damaging parts of the car, without danger to the operator and without physical effort. By following the simple instructions you get precise removal in no time.
- Supplied in a practical carrying case, available all the necessary parts to use.



Code	Desc.
4770006380	729

Spare Parts		
Article	Code	Desc.
Cutting wire section. 0.7 mm square - 44 m	4770006360	727
Thread guide lever with T-handle	4770005400	642
Teflon wedge	4770006430	734
Protective plate for the dashboard	4770006400	731
Protective plate small	4770006410	732
Band of protection for internal parts	4770006420	733

## Positioning arm for crystals



- Adjustable telescopic arm equipped with suction cups for the disassembly and the simple replacement by a single operator of the crystals car.
- Suitable for specialists in the field of repair of cars and vans: bodies, centers windshield replacement.
- The kit includes two suction cups, one for the arm is fixed on the glass descending on the driver side and one for the lifting of the crystal, a rotating support and a telescopic arm, which together allow to move crystals of large dimensions without effort and with absolute precision.
- The system allows a considerable saving of time and does not control the user to force it dangerous or harmful.

Code	Desc.
4770006390	730

## Cutting wire with a square section and triangular



- Range of cutting wire ultra professional for the replacement of the crystals car and VI
- Articles suitable for body shops and shopping windshield replacement.
- Meccanocar offers a wide range of cutting wires: a model with a square section of side 0.6 mm provided in practice reel 22 mt, the other pattern, a triangular section, provided in rolls of 25 mt
- The thread with a triangular section is the **top of the range** between the various wires, as it has a cutting capacity much higher than average, and a reduced section easily maneuverable for the operator.
- Both items can be used with our handles (art. 477 00 04800 to 339) and the lever locks the wire (art. 477 00 05360-638).

Code	Description
4770005370	639 - WIRE TRIANGULAR SECTION 25 MT
4770005380	640 - WIRE SQUARE SECTION 22 MT 0,6x0,6 mmm
4770006360	727 - WIRE SQUARE SECTION 44 MT 0,7x0,7 mm

## Braided wire for cutting



- Braided metal wire for cutting.
- Golden finish.
- Used in the bodywork for the cutting of gaskets and sealants of the windscreen.

Code	Desc.	Ø mm	Length mt
4770002340	234	0,75	22

## Handles for cutting wire



- Useful aluminum handles for pulling the cutting wire.
- Product suitable for body and windshield replacement companies.
- For use in combination with the cutting wire type ns. 477 00 02340-234.

Code	Desc.
4770004800	339

## Lever locks cutting wire



- Lever provided with wire drive system for facilitating the cutting of the car windshield.
- Article suitable for car bodies and industrial vehicles and centers windshield replacement.
- The lever makes it very practical to remove the crystals from car with steeply inclined windscreen where the lower part of the sealant is difficult to achieve.
- Use of this article allows you to drive any cutting wire so as not to damage instrument panels and moldings.

Code	Desc.
4770005360	638

## Needle drilled grommet cutting



- Special needle with a hole to insert the cutting wire.
- Product suitable for car bodies and industrial vehicles, repair centers crystals.
- The article is composed of a needle of length 100 mm, fully pierced along its entire length, which allows to easily pierce the sealant between the crystals of the same car and the frame for the passage of the cutting wire.
- The item is provided with practical handle which allows the needle to pass accurately and without risk to the operator.
- To optimize the use of the article recommends inserting the needle from inside car resting it in the desired drilling point and push with one hand on the rod to cause it to bend.
- Article to use in conjunction with our cutting wires (cod. 477 000 5370 to 639 cod. 477 000 5380 to 640) and our handles (art. 477 00 04800-339).

Code	Desc.
4770005350	637

## Thread guide lever T-handle



- Thread guide lever to pass the cutting wire through the sealing of the crystals.
- Product suitable for car bodies and industrial vehicles, repair centers crystals.
- The handle "T" shaped plastic allows greater force to the blade in the cutting operations.
- Article to use in conjunction with our cutting wires (cod. 477 000 5370 to 639 cod. 477 000 5380 to 640) and our handles (art. 477 00 04800-339).

Code	Desc.
4770005400	642



## Tool for fitting seals



- Suitable tool for the installation of rubber seals installed on certain cars, trucks and commercial vehicles.
- Article suitable for industrial vehicles bodywork car body, windshield replacement centers.
- The tool is composed of 8 mt of nylon rope passing through a handle holes.
- The curvature of the tool allows you to work in an ergonomic position and simplifies the operation of the passage of the cord inside the seal.
- Using this tool, the operator can change the cord avoid injury from broken glass.
- Supplied with lanyard 8 mt diameter 8mm to use the product on glasses also large.

Code	Description
4770005410	643 - TOOL ASSEMBLY SEAL
4770005415	643C - ROPE REPLACEMENT

## Seals fixed roller



- Specified tool for installation of the crystals with gasket so-called "with core"
- Article suitable for industrial vehicles bodywork car body, windshield replacement centers, workshops earthmoving.
- The tool is designed to facilitate the operations for fixing the soul into the seals of the windcreens of many construction equipment and agricultural equipment.
- The roller mounted on the end allows you to fix the soul easily and perfectly.
- The item is supplied with six different loops can be used on different sizes of seals.

Code	Description
4770005420	644 - FIXED SEAL BY ROLLER
4770005425	644R - SERIE EYELETS REPLACEMENT

## Suckers for crystal



- Jointed pair of suction cups for lifting and positioning of crystals car during the replacement operation.
- Article suitable for body shops and the replacement centers crystals.
- The high angle of the joint allows a secure fixation on the glass very well rounded. The adhesion strength of about 45 kg for suction cup with two heads makes safe the use of every type of crystal.
- Equipped with a slit on the handle for the passage of a tape tensioning device type our cod. 507 00 02800.

Code	Desc.
4770005430	645





## Maxi suckers for glasses



- Articulated pair of suction cups for lifting and placing the car windows during replacement operations. Larger for grasping and sealing even in large crystals.
- Items shown for automobile bodies and centers substitution crystals.
- The high angle of the joint allows secure fixing even in very curved crystals.
- The adhesion strength reaches 60 kg per suction cup two heads and makes the use is safe in any type of glass, even for large heavy media.
- Slot in the handle for the passage of tape type Tensionadora our code. 507 00 02800.

Code	Desc.
4770005435	646

## Manual knife for cutting gaskets windshield



- Knife blade interchangeable.
- Aluminum structure.
- Handle Bowden cable.
- With standard blade.
- Indicated for the cutting of the seals of the windscreen in the operations of replacement of the same.

Code	Description	Dimensions mm
4770002820	282 detach glass	240x90x24
4770002822	282L blade replacement	25 mm profile cutting

## Sealants scraper (scraper)



- Scraper (scraper) for professional cutting and finishing of the old sealant on the windows and bodywork on cars and trucks.
- Indicated for the body in general and for the centers windshield replacement.
- The use of the scraper allows to obtain a bead of sealant perfectly smooth and well finished on which to lay the new adhesive. The correct use, also allows you to leave the right thickness on the surfaces of old putty for the laying of the new.
- Comes with 5 blades width 16 mm contained in the handle. No other measures available as spares.

Code	Desc.
4770005440	647

Spare Parts		
Article	Code	Description
Blade width 12 mm	4770002382	238-12
Blade width 16 mm	4770002383	238-16
Blade width 20 mm	4770002384	238-20
Blade width 16 mm angled 35 °	4770002385	238-16/35°

## Pliers for staples



- Plier-specific staples.
- Indicated for the vehicle repair industry.
- Usable with our staples cod. 477 00 00041.

Code	Description
4770000042	4 / 2- Pliers for staples

## Staples for upholstery



- Staples for upholstery.
- Indicated for the vehicle repair industry

Code	Description
4770000041	4/1 100 series staples

## Clamp pierces sheets



- Pliers to pierce the edge of the workpiece.
- Ideal of fenders wheel arches and side platforms.
- Maximum drilling thickness mm 1.2.
- Drilling diameter mm

Code	Description
4770000140	14
4770000145	14/5 Punzone di ricambio

## Gripper fold sheet



- Pliers for bending the edge of the workpiece prior to welding.
- Maximum thickness of sheet metal folding 1.2 mm.

Code	Desc.
4770000150	15

## Tool open doors



- Lever spring steel with special shape.
- It opens quickly and without damaging the car doors.

Code	Desc.
4770000590	59

## Magnet antistatic

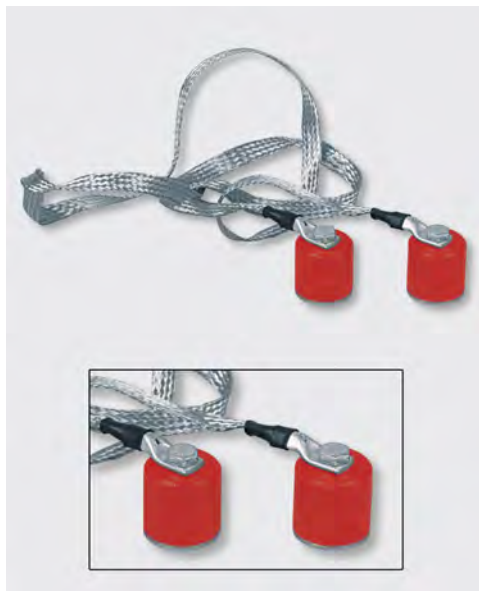

- Magnet antistatic coating oven.
- It allows a perfect painting because thanks to two magnets creates a discharge of static electricity from the part to be painted.
- Its use eliminates the problem of dusting of the paint, which by effect of electrostatic currents is deposited on the other walls of the bodywork and jeopardize the work done.

Code	Desc.
4770001480	148

## Key hinges VW-Audi



- Key to special angle.
- Essential for the disassembly of the bolt mounted on the door hinges of all VW; Audi.

Code	Desc.	Measures
4770001940	194	M10 XZN

## Key locks doors VW-Audi

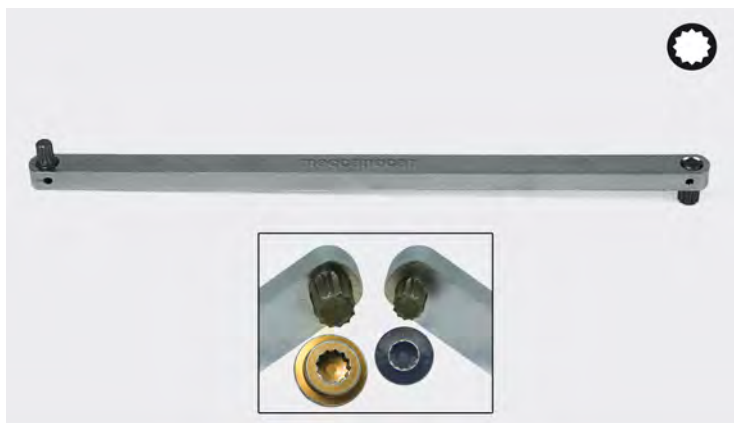

- Key to special angle.
- Double insert XZN M8 and M10.
- Indispensable for recording; the assembly and disassembly of the keeper locks VW; Audi.

Code	Desc.	Measures
4770001960	196	M8 XZN E M10 XZN

## Cartridge gun type silicon



- Cartridge gun silicones and adhesives professional.
- Body sheet metal and welded verniciatadi thick.
- Cast aluminum handle.
- New system of thrust practical and safe.

Code	Description
4430039810	443 PROFESSIONAL

## Cartridge gun type silicone bags and 400 ml



- Cartridge gun silicones and adhesives professional (400).
- Body tube thick aluminum.
- Cast aluminum handle.
- New system of thrust practical and safe.

Code	Description
4430039850	443 TUBE

## Cartridge gun type silicon



- Welded steel.

Code	Desc.
4430039800	443 P

## Pistola manuale per sigillanti in sacchetto 600 ml



- Pistola manuale professionale per l'applicazione di sigillanti in sacchetto con capacità fino a 600 ml. Costruita appositamente per l'estrusione anche di prodotti ad alta viscosità.
- Indicata per tutti i settori lavorativi: autocarrozzerie, trasformazione di veicoli, costruzione e posa infissi, carpenterie industriali, ecc.
- Impugnatura rivestita antiscivolo, frizione ed asta di spinta in acciaio temprato, tubo e ghiera di chiusura in alluminio. Rapporto di spinta 18:1.
- Peso: 1,17 Kg.

Code	Desc.
4430039880	443/600

## Pallets of aluminum work



- Folding pegs in aluminum for various machining operations in absolute safety.
- Used to elevate his position.
- Particularly suitable for body shops, mechanics, fitters and installers.
- The aluminum construction with steel joints fully riveted makes treadmills extremely robust, stable and indestructible. light weight makes them easy to handle, and the large platform ensures maximum safety in use.
- Available in different sizes in height, length and height: couple in the small and medium, single large.
- range Kg. 120

Code	Desc.	Platform measure cm	Type
4700005200	2590	Length .: 100. W .: 30. H from the ground: 29. Leng .: 128. Width .: 30. H from the ground: 52.	Two footboards small
4700005300	2595	Length .: 135. W .: 40. H from the ground: 79.	Large single pla

8

## adjustable stool



- Height-adjustable stool.
- With support plate.
- The further revolving pan.
- It allows you to keep everything you need at hand.
- Seat in sky.
- Load 150 kg.
- Ideal for work in the workshop and bodywork.

Code	Desc.	Dimension h-min-h-max
4700003700	2559	380-510



## Stand for windshield



- Tripod for the support of the windshield even of big size.
- Supporting arms with protective foam.
- The chain clamp allows a maximum opening of 1000 mm.
- Iron powder.



IDEALE PER  
CARROZZERIE  
E CENTRI  
SOSTITUZIONE  
CRISTALLI

Code	Desc.	Dimensions mm
4700000080	124	1300x800

## Tripod support with shelf



- Tripod made of galvanized sheet adjustable in height.
- With sheet metal shelf.
- Particularly suitable for the body to support the operations of sheet metal and crystal replacements.

Code	Desc.	Dimension cm
4700000094	125/P	P.100 L.40 H.106

## Tripod support



- Lightweight tripod made of galvanized sheet.
- Height adjustable chain.
- Particularly suitable in body shops for support of sheet metal during the operations of sanding, puttying etc ..

Code	Desc.	Dimension cm
4700000092	125/E	P.100 L.40 H.106

## Repair Kit body 4 Ton



- Hydraulic system to push, pull, enlarge and join the bodywork of cars, industrial vehicles, earthmoving, etc..
- Product suitable for body shops, workshops transformation commercial vehicles, metal structures, etc.
- The body kit 470 00 03693 is not compatible with the previous model.
- The thrust capacity of the kit varies depending on the number and type of accessories that are used.



### CONTENUTO KIT 2558/A

Accessorio	Fig. n°	Accessorio	Fig. n°
Pompa idraulica + Tubo AP 1,5 mt	1	Piastra spingidisco 60x110 mm	9
Pistone Idraulico 4 ton Ø 22mm	2	Piastra spingidisco a V	10
Allargatore martinetti per carrozzeria	3	Piastra spingidisco inclinata	11
Prolunga 440 mm	4	Cuneo	12
Prolunga 330 mm	5	Pistone inclinato	13
Prolunga 245 mm	6	Testa in gomma Ø 70mm	14
Prolunga 135 mm	7	Cilindro zigrinato Ø 35 mm	15
Adattatore 70 mm	8	Valigetta in ABS (170 x600 x 300)	

Code	Desc.	Portata
4700003693	2558/A	4 TON

Tecnical Features	
Pressione (bar)	70
Olio (cc)	27
L. min. cilindro (mm)	27
L. max cilindro (mm)	37
Hydraulic stroke (mm)	10
Peso Kg	18,

Spare Parts		
Article	Code	Desc.
Kit M + F connector for hydraulic unit	4700003688	2558R

## Repair Kit body 10 Ton



- Hydraulic system to push, pull, broaden and unite the vehicle body, industrial vehicles, earthmoving, etc..
- Product suitable for body shops, workshops transformation industrial vehicles, workshops mov. earth, etc.
- The body kit 4700003697 is not compatible with the previous model.
- The thrust capacity of the kit varies depending on the number and type of accessories that are used.
- Supplied in carrying case with wheels for easy transport.



CONTENUTO KIT 2588/A			
Accessorio	Fig. n°	Accessorio	Fig. n°
Pompa Idraulica + Tubo AP 1,5mt	1	Piastra spingidisco 95x150 mm	9
Pistone Idraulico 10 ton Ø 33mm	2	Piastra spingidisco a V	10
Allargatore martinetti per carrozzeria	3	Piastra spingidisco inclinata	11
Prolunga 500 mm	4	Cuneo	12
Prolunga 400 mm	5	Pistone inclinato	13
Prolunga 300 mm	6	Testa in gomma Ø 75mm	14
Prolunga 170 mm	7	Cilindro zigrinato Ø 50 mm	15
Adattatore 95 mm	8	Valigetta in ABS (950 x 380 x 160)	

Code	Desc.	Portata
4700003697	2588/A	10 TON

Tecnical Features	
Pressione (bar)	70
Olio (cc)	70
L. min. cilindro (mm)	37
L. max cilindro (mm)	53
Hydraulic stroke (mm)	16
Peso Kg	30

Spare Parts		
Article	Code	Desc.
Kit M + F connector for hydraulic unit	4700003688	2558R
Hydraulic piston 10 ton diam. 33mm	4700003696	2588P
Slanted piston	4700003689	13
Head in rubber diam.75mm	4700003686	3697/P10



## Bubbles remover kit for car bodies



FORNITO IN VALIGETTA

PISTOLA A CALDO



TERMOFFIATORE



APPLICAZIONE



- System quick and easy to restore small Dent on the body.
- Particularly suitable for restoring body affected by hail.
- It equipped with a practical pliers for the draft, 10 sticks of hot glue (hot melt) in black and 4 different sizes of mushrooms.
- For the use it is essential the aid of a heat gun type 3930000100 or 3930000600.
- For all the bodies.
- Note: on the mushroom bodies repainted in the draw could remove the paint.
- **INSTRUCTIONS:** Locate the size of the mushroom suitable depending on the size of the damage to be restored, the mushroom paste with hot glue through the gun, once that's done, place the clamp to draw on the fungus, providing to the adjustment of the air draft through the knurled screw positioned on the clamp, in a manner perpendicular, once hooked the fungus to the caliper, to start the restore operation using the lever until the complete recovery of the sheet. When finished, release the mushroom from the calipers to the detachment of the fungus, use a heat blower to soften the glue, then remove the fungus.

Code	Description
4770002870	287 BUBBLES REMOVE KIT

Spare Parts	
Code	Description
4770002871	15- Mushroom parts
4770002872	20- Funghetto di ricambioMushroom parts
4770002873	25- Mushroom parts
4770002874	32- Mushroom parts



## Punches for drilling bumper parking sensors



- Punches in specific steel for drilling of bumpers and plastic parts is rough or coated, specific for the application of the parking sensors without the use of finishing frames
- The punches are of the measures used in this type of machining: 17, 18, 19, 20, 21 and 22 mm. For use, you must make a pre-hole diameter 8 mm on the bumper, inside and out to apply the two sides of the punch united by steel M8 screw and tighten with a 13 mm wrench or ratchet up the realization of the hole.
- The processing is done perfect, flawless and with perfectly smooth edges and well finished, in order to avoid having to further finishing operations.
- Complete kit available from 7 pieces, tipped HSS, and all bulk punches in different sizes.



Code	Description	Content
4770006780	748 - Complete kits punches	Punches: 17, 18, 19, 20, 21, 22 mm. Tip in Hss 8 x 120 mm

Spare Parts		
Code	Desc.	Ø Punch mm
4770006790	748/17	17
4770006800	748/18	18
4770006810	748/19	19
4770006820	748/20	20
4770006830	748/21	21
4770006840	748/22	22





## Plastic repair kit 2



8

- Kit of second generation for the repair of plastic parts of each type, with carry-over hot of the missing part or cords for reinforcement.
- The article is suitable for automotive, industrial vehicles, transformation, and also for many applications in the areas of maintenance, repair of tanks and plastic containers, maintenance, etc.
- Typical applications of the automotive industry are: repair of bumpers, shells outside mirrors, dashboards, boxes, lids, caps radiator cowlings and fairings for motorcycles and scooters, tanks for liquids, coatings batteries, headlights, etc.
- Repairs carried out with the kit consists Meccanocar nell'appostare material equal in every way to what we are repairing, and merge together in order to create a single body which later will be 'worked smoothing it and bringing it back to its original shape. Using a network of stainless steel reinforcement will allow 'the secure estate and eternal.
- Standard: 1 soldering iron with electronic power / temperature, 1 terminal bronze standard perforated, 1 terminal bronze plate, 8 types of filler material in sticks or rolls, one reinforcing mesh stainless steel plate 1 d 'support for the welder, 1 steel brush for cleaning tips, detailed handbook and CD information.

Code	Desc.	SupplyV / Hz
4770005020	350HT	220-50

Spare Parts				
Article	Code	Description	Photo	
PUR-RIM - transparent polyurethane roll	4770005021	350/R1	/	
PP - Polypropylene black chopsticks	4770005022	350/R2	/	
ABS - Abs white chopsticks	4770005023	350/R3	/	
PE - Polyethylene translucent chopsticks	4770005024	350/R4	/	
TPO-TEO-TPE- OPT gray chopsticks	4770005025	350/R5	/	
NYLON-PA - Nylon opaque white roll	4770005026	350/R6	/	
POLYCARBONATE - Polycarbonate transparent chopsticks	4770005027	350/R7	/	
Fiberflex-sticks Universal reinforced with fiberglass	4770005028	350/R10	/	
Reinforcing mesh stainless steel 250 X 120 mm	4770005029	350/RM	/	
Terminal brass standards with passage hole	4770005031	350/HT2	1	
Terminal brass plate off	4770005032	350/RT	2	
Transformer / power regulator	4770005033	350/TC	3	
Welder parts reinforced	4770005030	350/HT1	4	

## Restore thermal plastic

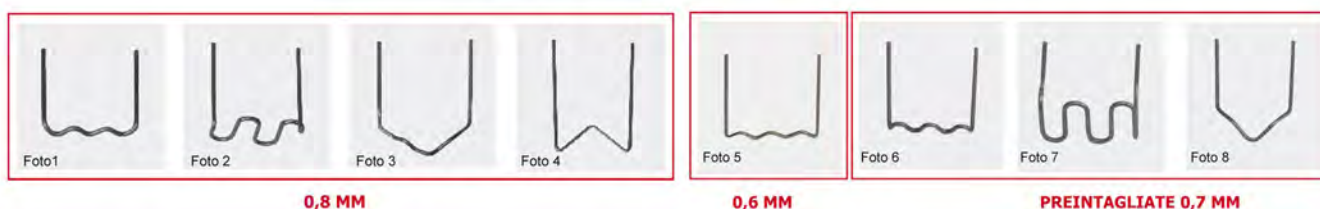

- Kit easy to use for the repair and reinforcement of breakage of plastic objects. It allows to gather the break points and strengthen them in order to weld them finally with the appropriate paper clips shaped steel inside.
- Usable in any sector of repair and maintenance: body shops, repair motorcycles and scooters, repair of trucks, maintenance of civil and industrial, etc.
- The kit consists of a series of staples of different shapes and sizes, bent to "U", which are heated dall'apposito welder with push of the terminals. the heated staple penetrates the plastic and stays in it by joining the edges of the tear and reinforcing the whole. The process takes a few seconds.
- Following repair, the piece can be repaired plastered, filled, sanded and repainted.
- Kit Contents: station power control and temperature, soldering iron with push of staples, paper clips assorted assortment of four different shapes and sizes.



Code	Description
4770006870	751

Spare Parts			
Article	Code	Description	Photo
Paperclip to U 0,8 mm	4770005790	702	1
Paperclip to S 0,8 mm	4770005800	703	2
Paperclip to V 0,8 mm	4770005810	704	3
Paperclip to M 0,8 mm	4770005820	705	4
Paperclip to U 0,6 mm	4770005870	710	5
Staple pre-carved to U 0,7 mm	4770005880	711	6
Staple pre-carved to S 0,7 mm	4770005890	712	7
Staple pre-carved to V 0,7 mm	4770005900	713	8

Tecnical Features	
Tensione di alimentazione V - Potenza W	220-5
Lunghezza cavo di alimentazione mm	1650
Dimension mm	170 X 90 X 90
Lunghezza cavo saldatore mm	1700
Peso g	1650

## Induction heater 1 kW Easy Ductor



8

- Innovative induction heater for parts in iron and steel, portable, easy to use, the power of 1 kW and current operation 220 Volts - 50 Hz network. Its compactness and power section separate from the handle allow it to be used anywhere you have a standard electrical outlet.
- Is used to heat up wanting to red heat: nuts, bolts, pipes, drainage systems, water pipes and gas, any particular built of iron or steel provided they have magnetic properties. It replaces in full the oxyacetylene flame to heat or unlock each thread seized by rust. The heat is distributed only on the process step by not affect the surroundings and ruin delicate parts.
- It can be used to heat sheet metal and help the detachment of adhesives and moldings, to heat pipes to facilitate the folding, for quickly removing paint surfaces in iron and steel.
- The separate generator increases the safety of use, away from the operator maintains the electromagnetic influences, allows an optimal cooling for a long time use of the device without overheating and interruptions.
- Equipped with power cord neoprene anti-oil and anti-cut length 2.20 m power cable for the neoprene handle anti-oil and anti-cut length of 5.00 m with metal connector screw, case power unit with stainless steel sink finned aluminum case of the grip of impact resistant plastic.
- Spirals copper coated with insulating Heat, easily moldable and long life, can be installed on all machines on the market without problems.
- Standard equipment: power unit from 1 Kw, handle shock-proof plastic, three spirals with inner diameter of 20, 25 and 30 mm, a spiral heating surfaces, plastic carrying case for storage and transportation.

Code	Desc.
4770006440	735

Spare Parts		
Article	Code	Desc.
Spiral inner diameter 20mm front	4770006450	736/20
Spiral internal diameter 25 mm front	4770006460	736/25
Spiral inner diameter 30mm front	4770006470	736/30
Spiral inner diameter 20mm side	4770006480	737/20
Spiral internal diameter 25 mm side	4770006490	737/25
Spiral inner diameter 30mm side	4770006500	737/30
Spiral diameter 55 mm for heating surfaces	4770006510	738
Free wire 1.100 mm	4770006520	739

Technical Features	
Peso impugnatura	1,7 Kg
Handgrip dimensions	42X10X10 cm
Normative	CEI EN 55011 CEI EN 6100-varie CEI EN 61010
Peso generatore	3,0 Kg
Generator dimensions	35X25X15 cm
Power supply cable length (cm)	220
Lunghezza cavo di potenza (cm)	500
V/Hz power supply	220/50
Fusibile di protezione	16 A
Potenza assorbita	1,0 Kw

## Key Chain



- Reinforced model.
- Also suitable for use pipe wrench.

Code	Desc.	For filters Ø max
4430040200	447	110

## Key double chain



- With swivel head.
- For oil and fuel filters.

Code	Desc.	For filters Ø max
4430040840	458	120
4430040842	460	145

## Key Chain



- Double link chain thin.
- Hex shank 19 "to maneuver.

Code	Desc.	For filters Ø max
4770001430	143	

## Strap wrench



- Belt slip material.

Code	Desc.	For filters Ø max
4430040300	448 A	140



## Strap wrench off

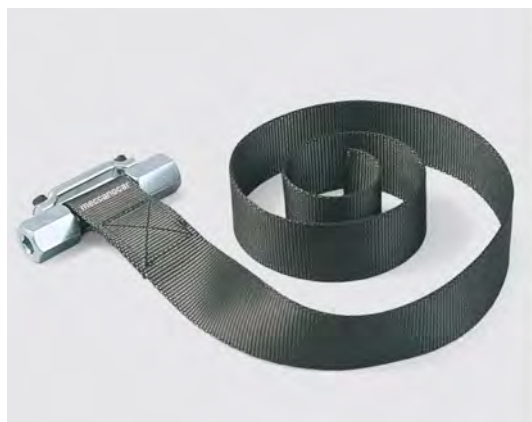

- Wide belt fabric.
- High grip and slip resistance.
- Ideal for all types of filter.
- To remove the filters double dryers.
- Double square drive 3/8 "and 1/2" for the maneuver.

Code	Desc.	For filters Ø max
4430045150	545	300

## Strap wrench



- Nylon tape special.
- Striker framework 1/2 "for the maneuver.

Code	Desc.	For filters Ø max
4770000730	73	152

8

## Key Metal Tape



- Particularly suitable on French cars.
- Adjustment knob on the handle.

Code	Description	For filters Ø max
4430043500	482	60 - 105
4430043510	482 R Ribbon Replacement	-

## Key to end articulated



- 180° swivel handle for easier grip in uncomfortable places.
- Steel band gear skid.

Code	Desc.	For filters Ø max
4770001680	168	60-66*
4770001030	103	76-85
4770000430	43	88-98



## Cup key in special steel



- Cup key in special steel.
- With square 3/8 ".
- With internal polygon.

Code	Desc.	For filters Ø	N° sides
4770000410	41	76	14
4770000420	42	90	15

## Wrench adjustable cup



- Key to large expansion adaptable to most of the filters on the market.
- The retaining spring makes sure that the steel jaws are gripping the filter without slipping.
- Square drive 3/8 ".

Code	Desc.	For filters Ø
4770000630	63	63 - 80
4770000631	63/1	79 - 98

## Key to 3 feet



Code	Desc.	For filters Ø
4770001220	122	65-120 mm

## Oil filter wrench



- Cartridge filter wrench from 65-120mm for cars
- Cartridge oil filter wrench with knurled edges for a secure grip of the filter
- Extremely robust
- Supplied with 3/8" panel attachment and a 1/2" adapto

Code	Desc.	Range
4770001221	122/1	65-120 mm

## Oil filter wrench for trucks 15-sided 106 mm



- Polygonal wrench for removing the oil filter.
- Suitable for workshops v.i and hauliers.
- Specification for trucks IVECO.
- 15 sides.
- Diameter: 106 mm.
- Connection 1/2.
- Sized spanner 24mm.

Code	Description
4770004000	313-KEY OIL FILTER DIAMETER 106 MM

## Socket wrench



- Special wrench socket.
- Square drive 1/2 "- M 36.
- Small footprint.
- Oil filters for diesel Mercedes E class - C and BMW.

Code	Desc.
4770001820	182

8

## Key band filter dryer



- Square drive 1/2 ".
- Steel band h75 mm for a sure grip on the filter.
- Extremely robust.

Code	Desc.	For filters Ø
4770002810	281	130-143

## Kit keys cup oil filters (30 pieces)



- Practical and comprehensive case key oil filters.
- Product suitable for machine shops and distributors.
- The case consists of 28 keys cup square drive 3/8" covering various applications, an enhancer to drive with levers or ratchet 1/2", 1 wrench to spider filter diameter from min 65 mm to 120 mm.

Code	Desc.
4770004750	335

Codice	Descrizione	N° lati	Attacco	Applicazione
4770006570	744-66/6	6	3/8"	Fiat Punto-Renault Clio 1.2 ,Express,Kangoo,Twingo
4770006575	744-65/14	14	3/8"	Napa,Purolator,Daihatsu, Toyota,Nissan
4770006580	744-65/67	14	3/8"	Daihatsu
4770006585	744-68	14	3/8"	Mazda,Ford Escort,Subaru
4770006590	744-73	14	3/8"	Toyota,Lexus
4770006595	744-74	15	3/8"	GM,Rover,Chrysler,Audi
4770006600	744-74/76	15	3/8"	Fram,Saturn
4770006605	744-75/77	15	3/8"	Audi,Mercedes,Opel
4770006610	744-76	8	3/8"	Fiat Marea,Lancia Delta
4770006615	744-76	12	3/8"	Fiat Ducato,Scudo;Ulisse-Renault Megane,Laguna,Espace
4770006620	744-76	14	3/8"	Vw,Porsche,Mercedes,Bmw, Audi A3td
4770006625	744-76	30	3/8"	Ford
4770006630	744-78	15	3/8"	Nissan,Ford,Toyota Accord
4770006635	744-80	15	3/8"	Isuzu,Subaru,Nissan,Honda, Mazda,Opel,Toyota

Codice	Descrizione	N° lati	Attacco	Applicazione
4770006640	744-80/82	15	3/8"	Subaru,Mazda,Honda
4770006645	744-86	16	3/8"	Volvo S40-60-70-80 ecc..
4770006650	744-86	18	3/8"	Audi A6, Renault,Citroen,Peugeot
4770006655	744-90	15	3/8"	Mitsubishi,Isuzu
4770006660	744-92	10	3/8"	Fiat Croma,500,Panda
4770006665	744-93	15	3/8"	Opel,Mazda,Volvo,Nissan, Vw,Porsche,Renault,Audi
4770006670	744-93	36	3/8"	Ford
4770006675	744-93	45	3/8"	Vw,Audi tdi
4770006680	744-95	15	3/8"	Toyota,Alfa,Ford,
4770006685	744-96	18	3/8"	Audi A4-A6tdi,Vw,Renault 2.2d
4770006690	744-100	15	3/8"	Isuzu
4770006695	744-106	15	3/8"	Fiat Ducato 2.5D,Td
4770006700	744-108	15	3/8"	Volvo C70,S70,V70
4770006705	744-108	18	3/8"	Renault Espace,Laguna,Master, Safrane,Trafic
4770001220	122		3/8"	Chiave regolabile da 65a120mm
4200001238	1/2F-3/8M		3/8" -1/2"	Adattatore per chiavi filtro 3/8M - 1/2F

## Kit keys cup oil filter (9 pieces)



- Practical and comprehensive case key oil filters for heavy vehicles.
- Product suitable for machine shops and commercial vehicles or industrial distributors.
- The case consists of 7 keys cup square drive 1/2" covering a variety of applications in the cargo sector, a strap wrench for filters up to 160mm, a ring wrench to operate the keys in the cup.

Code	Desc.
4770004810	340

Codice	Descrizione	N° lati	Attacco	Applicazione
4770006735	745-36	6	1/2"	Mercedes Axor Br400, Atego Br900, Br500, Scania PdeV8-hpi-motor
4770006750	745-74	14	1/2"	Mercedes Sprinter 600, Vw Trasporter
4770006710	745-106	15	1/2"	Man Serie L 2000, Scania Pde-motor, Fiat Ducato 2.5D, Td, Iveco
4770006715	745-107	15	1/2"	Volvo, Iveco, Renault, Scania
4770006720	745-108	15	1/2"	Volvo, Iveco, Renault, Scania
4770006725	745-108	18	1/2"	Renault Trasporter, Master, Trafic, Opel Movano
4770006730	745-135	18	1/2"	Man 18-48 serie F2000, Tga
4770006740	745-160		1/2"	Chiave a nastro x filtri d. max 160mm
4770006745	745-21			Chiave poligonale per manovra filtri

8

## assortment of oil pan caps



- Insert series with hexagonal 3/8" socket / door inserts square drive 1/2".
- They can operate on almost all oil plugs.
- Contents No. 6 inserts + 1 compass door inserts.

Code	Desc.	Content/size
4430040875	40085	Q8xQ10 8x3 / 8 10x11 12x13 14x17 19 + Bushing brings inserts

## Key oil plugs Audi A4



- Socket wrench special attack.
- 1/2".
- Essential for operating on oil plugs Audi A4 with transmission 01A profile XZN M 16 with the guide hole.

Code	Desc.
4770001780	178

## Key oil plugs VW / Audi 4WD, Mercedes



- Socket wrench special 1/2 ".
- Profile Torx TX70 with guide hole.
- Indispensable to operate on the oil plugs gearbox and differential on VW / Audi and Mercedes 4WD.

Code	Desc.
4770001790	179

## Filter wrench multijet diesel engines



- Key three-legged adaptable engines 1.3 16V Multijet.
- With square 1/2 ".
- Suitable for workshops authorized and not.

Code	Desc.	Attachment
4770003050	305	1/2

## Cup filters for diesel engines multijet



- Metal bowl to be used with the filter wrench multijet diesel.
- Locks the filter during removal thanks to bench vise.
- Essential to prevent damage to the fuel filter.
- Factory authorized and not.

### APPLICATIONS:

- **Fiat:**

Punto engine 1.3mj16v

Panda engine 1.3mj16v

Idea engine 1.3mj16v

Doblo' engine 1.3mj16v



Code	Desc.
4770003060	306

## Keyword filters for diesel engines HDi



- The HDi engines are mounted on Peugeot and Citroen.
- Factory authorized and not.
- The key is indispensable because the ring that closes the filter can not be removed with a normal key.

Code	Desc.	Attachment
4770003070	307	1/2 "



## Filter wrench diesel engine cdi



- The engines are mounted on vehicles cdi Mercedes.
- Factory authorized and not.
- The key is indispensable because the ring that closes the filter can not be removed with a normal key.

Code	Desc.	Attachment
4770003080	308	1/2 "

## Manual pump for oil



- Ideal for filling or topping up oil engine, gearbox and differential.
- Delivery capacity of 0.2 liters for pumped full.
- Equipped with hose 1.5 M and terminal curved.

Code	Desc.	Capacity Lt	Delivery x stroke
4430045595	597	16	LT 0,2

## Rotary pump for oil



- Piston pump for oil, fuel oil and kerosene.
- Delivery: 50 l / min.
- Telescopic suction tube.
- Not suitable for aqueous / corrosive.

Code	Desc.
4430044950	523

## Hand pump for oil and diesel



- Ideal for all types of oil and diesel fuel.
- Drum lt 50/200.
- Complete with bracket for attachment to the stem.
- Heavy pipe telescopic.
- Not suitable for aqueous / corrosive.

Code	Desc.	Delivery x stroke
4430049410	928	LT 0,5

## Manual pump for antifreeze and washer



- Manual pump for dispensing liquids antifreeze, washer and all kinds of water-based product from metal drums of capacity 50 to 200 liters.
- Telescoping suction tube, threaded body for fixing on the hydraulic drums. Made entirely of metal with tube of metal and rubber hose with metal spout for dispensing.
- Pumping capacity: 0.5 liters per cycle.

Code	Desc.	Delivery x stroke
4430049430	930	0.5 liters / cycle

Spare Parts			
Accessories	Code	Desc.	
Adapter for plastic drums	4430049432	930/2	

## Lever pump for transferring liquids



- Polypropylene pump ( PP )
- Internal piston in AISI 316 stainless steel with Viton sealing gaskets
- Telescopic scavenging tube suitable for 50 kg to 200 kg cans
- Adjustment of the fulcrum of the pumping lever for low viscosity liquids such as water
- Thanks to its construction, it is ideal for transferring water, oil, diesel, alcohols, antifreeze, acetone and petrol

Code	Description
4430057418	1792.PG pompa a leva in PP

Tecnical Features	
Weight kg	1,2
Used with can or tank	50-200kg
Sealing gasket	Viton
Product outlet attachment	M3/4 bsp
Pump flow capacity	0,5l

## Oiler portable



- Oiler heavy plate painted.
- Brass pump.
- Flexible tube.

Code	Desc.	Capacity gr.
4430034200	388-200	200
4430034210	388-300	300
4430034220	388-500	500

## Syringe for oil.



- Rigid spout ø 8 mm.
- Brass body.

Code	Desc.	Capacity	L. tot.
4430044200	489	500	480 mm

## Syringe for oil change / Differential



- Flexible spout.
- Steel body.

Code	Desc.	Capacity gr.	L. tot.
4430044860	515	500	590 mm

## Hand pump double acting



- Pump multifunctional: for every pump sucks and ejects liquids such as oils and fuels.
- It allows to execute transfer operations without the use of containers or funnels.

Code	Desc.	Pouring capacity	L. tot.
4770001320	132	260 ML	600 mm

## Complete kit for fat 25 kg



- Complete kit for fat content from 25 kg: 1 trolley for drums, one pump should 25kg, 1 triple junction, one drum cover diameter 310mm, 1 high pressure hose 3 m, 1 ns cod.4430047880 grease gun, 1 follower plate diameter 285mm, ns 4430049415 cod.
- We recommend the use of drums 24 kg and our cod.4110014840 4,110,016,595.
- Pneumatic pump for lubrication at high pressure using all kinds of fat.
- Indicated in the areas most prone to constant lubrication (car, mov. Land, industrial vehicles, etc.).

Code	Desc.	For buckets Kg
4430047890	867	25

Tecnical Features	
Air consumption	500 l /min
Massima gradazione	NLGI-2
Lunghezza asta pompante	480 mm
Pumping external diameter	30 mm
Grease outlet connection	3/8" M
Air inlet connection	1/4" F
Pressione max di uscita	480 bar
Portata	1800 gr /min.
Rapporto di compressione	65:1
pressione di utilizzo min./max.	5-8 bar

Spare Parts	
Code	Description
4430047892	867/P Pump grease Kg 25



## Complete kit for fat to 50 Kg



- Complete kit for fat content from 50 kg: 1 trolley for drums, one pump should 50-60kg, 1 triple junction, one drum cover diameter 385mm, 1 high pressure hose 3 m, 1 ns cod.4430047880 grease gun, 1 follower plate diameter 370mm our code 4430049420.
- Pneumatic pump for lubrication at high pressure using all kinds of fat.
- Indicated in the areas most prone to constant lubrication (car, mov. Land, industrial vehicles, etc.).

Code	Desc.	For drums Kg
4430047875	864	50

Tecnical Features	
Air consumption	500 l /min.
Massima gradazione	NLGI-2
Lunghezza asta pompante	740 mm
Pumping external diameter	30 mm
Grease outlet connection	3/8" M
Air inlet connection	1/4" F
Pressione max di uscita	480 bar
Portata	1800 gr /min.
Rapporto di compressione	65:1
Pressione di utilizzo	5-8 bar

Spare Parts	
Code	Description
4430047876	864A Aerosolometer Kg.50

8

## Aero-vacuum pump for 200 kg fat



- Pneumatic pump for the suction of fat, for 200 kg drums.
- Indicated in the automotive, industrial vehicles and earth moving.

Code	Desc.	Capacity (Kg)
4430045583	594/1	200

Tecnical Features	
Air consumption	500 l /min
Massima gradazione	NLGI-2
Lunghezza asta pompante	940 mm
Pumping external diameter	30 mm
Grease outlet connection	3/8" F
Air inlet connection	1/4" F
Portata	1800
Pressione max di uscita	480 bar
Pressione di utilizzo	5-8 bar
Rapporto di compressione	65:1

## High pressure hose to pump should - fat



- Grease tube complete with fittings for connecting the pump should supply gun.

Code	Desc.	Length m	Press. Eserc. Bar	Attachment
4430049440	932/2	2	400	1/4M+1/4F
4430049442	932/6	6	400	1/4M+1/4F



## Dispensing gun grease



- Gun with coupling head and greasing.

Code	Desc.	Attachment
4430047880	865	1/4 F

## Manual pump grease



- Use loose grease.
- Complete with tube A.P. and head greasing.
- Capacity 16 Kg

Code	Desc.	Melted fat capacity
4430045395	580	16 Kg

## Greaser compressed air



- Greaser used with grease cartridges 600 g. (our art. 411 00 411 00 03700 to 2622 and 14625 to 2737) and with loose grease up to 800 grams.
- Body diameter 60 mm.
- Length 500 mm.
- It can 'be powered with the air of the tractor truck.
- Complete with 2 cartridges lithium grease.

Code	Desc.	Operating press. BAR
4430033800	384	6 - 10

## Grease gun



- Greaser used with grease cartridges 600 g. (n / s art. 411 00 411 00 14625 03700-2622 and 2737) and with loose grease up to 800 grams.
- Body diameter 60 mm.
- Length 460 mm.
- Accompanied by the first cartridge lithium grease.

Code	Desc.
4430044430	494

8

## Manual grease gun 450 cm<sup>3</sup> (400 g)



- Grease gun for the use of cartridges 400 g., Diameter 53 mm, or bulk grease.
- Stop rod with lever, knurled grip handles, high boost pressure.

Code	Desc.
4430053930	1083

## Tube A.P. grease fitting



- Hose assemblies for greasers our art. 4430033800 to 384 / our art. 4430044430-494 and our art. 4430053930-1083

Code	Desc.	Length cm
4430033805	384/50	50
4430033810	384/100	100
4430033811	384/150	150

## Heads for grease

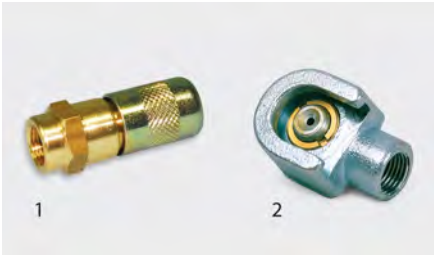

- Grease fitting standards.
- Grease fitting hexagon.

Code	Desc.	For lubricator type	Photo
4070002200	1420	ROUND	1
4070002300	1430	HEXAGONAL	2

## Greasers



Code	Desc. Diam. X passo x type
4070000100	6 x 1 - H1P
4070000200	6 x 1 - H1L
4070000300	6 x 1 - H 1
4070000400	8 x 1 - H 1
4070000500	8x1,25 - H 1
4070000600	1 0 x 1 - H 1
4070000700	10x1,25 - H 1
4070000800	10x1,5 - H 1
4070000850	1/4 GAS - H 1
4070000900	6 x 1 - H 2
4070001000	8 x 1 - H 2
4070001100	8x1,25 - H 2
4070001200	1 0 x 1 - H 2
4070001300	10x1,25 - H 2
4070001400	10x1,5 - H 2
4070001500	6 x 1 - H 3
4070001600	8 x 1 - H 3
4070001700	8x1,25 - H 3
4070001800	1 0 x 1 - H 3
4070001900	10x1,25 - H 3
4070002000	10x1,5 - H 3

## Assortment greasers



- Contents: 17 measures of grease from diam. 6 in diam. 10, H1 + H2 + H3 + n ° 2 heads with 4 jaws.
- Total 172 pieces.
- Supplied in a plastic carrying case n / s cod. 398 00 01800 201.

Contenuto kit

CODICE	DESCRIZIONE	Q.tà
4070000100	6X1-H1P INGRASSATORE	10
4070000300	6X1-H1 INGRASSATORE	10
4070000400	8X1-H1 INGRASSATORE	10
4070000500	8X1.25-H1 INGRASSATORE	10
4070000600	10X1-H1 INGRASSATORE	10
4070000700	10X1.25-H1 INGRASSATORE	10
4070000800	10X1.5-H1 INGRASSATORE	10
4070000900	6X1-H2 INGRASSATORE	10
4070001100	8X1.25-H2 INGRASSATORE	10
4070001200	10X1-H2 INGRASSATORE	10
4070001300	10X1.25-H2 INGRASSATORE	10
4070001400	10X1.5-H2 INGRASSATORE	10
4070001500	6X1-H3 INGRASSATORE	10
4070001700	8X1.25-H3 INGRASSATORE	10
4070001800	10X1-H3 INGRASSATORE	10
4070001900	10X1.25-H3 INGRASSATORE	10
4070002000	10X1.5-H3 INGRASSATORE	10
4070002200	1420 TESTINA INGRAS. 4 GRIFFE	2

Code	Desc.
4070100100	18



## Aero vacuum pump oil 200 kg



- Pneumatic pump for suction of oil and waste oil.
- To 200 kg drums.
- Indicated in the automotive, industrial vehicles and earth moving.

Code	Desc.
4430045580	594

Tecnical Features	
Air consumption	110
Massima gradazione	SAE 150
Lunghezza asta pompante	940 mm
Pumping external diameter	42 mm
Oil outlet connection	1/2" M
Air inlet connection	1/4" F
Portata	16L/min
Pressione max di uscita	480 bar
Pressione di utilizzo	5-8 bar
Rapporto di compressione	3:1

## High pressure hose to pump should - Oil



- Hose for oil complete with fittings.
- For connection to the pump should supply gun M + F 1/2.

Code	Desc.	Length m	Press. Eserc. Bar	Attachment
4430045590	596/2	2	30	1/2M+F
4430045592	596/5	5	30	1/2M+F

8

## Dispensing gun for oil



- Grease gun oil with beak bent.

Code	Desc.	Attachment
4430045585	595	1/2" F

## Nozzle meter for oil



- With digital counter.
- Maximum accuracy and reliability.
- Reading on the LCD, immediately and without errors.
- Partial zeroing.
- With drip spout.

Code	Desc.	Attachment
4430049405	927	1/2" F

## Inertia reel for oil



- Fed from a pump should.
- With specific pipe for the passage of oil.
- Supplied with pump nozzle and bracket.
- For wall mounting.

Code	Desc.	Length <i>m</i>	Attachment
4430049395	925	15	3/8" F

## Adblue kit with manual pistol



- Kit with tube and manual pistol per dispensing Adblue by gravity
- Suitable for 1,000 litre can holder
- 3/4" Epdm tube, length 5 m
- 3/4" bps-F tube attachment

Code	Description
4430057412	1770.URC9 KIT ADBLUE

## Stainless steel bracket for pistol

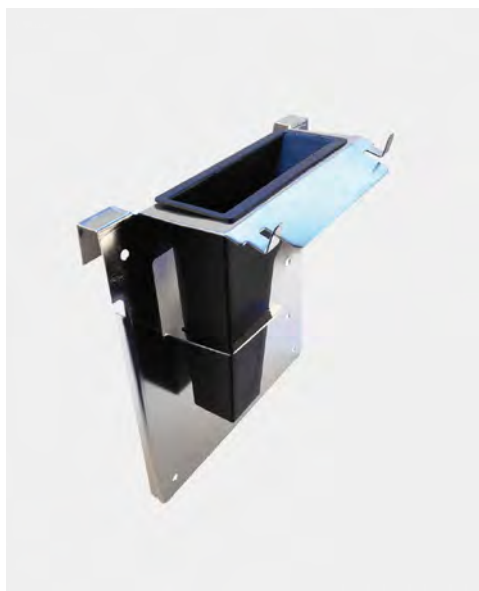

- Stainless steel bracket attachments for can holder
- Permits housing the dispenser pistol P { margin-bottom: 0.21cm; }

Code	Description
4430057414	Staffa inox per pistola



## ADBLUE kit for can holders of 1,000 litres.



- Dispenser kit with 230V electric pump
- for can holders of 1,000 litres
- with dispenser pistol
- Complete with stainless steel bracket (4430057414 )
- The can holder is not included in the kit

Code	Description
4430057408	1770.URA9

## Digital litre counter pistol for Adblue



- Litre counter pistol with double outlet
- Permits utilisation in the car sector and the industrial vehicle sector
- 15 mm diameter outlet for cars and 19 mm diameter outlet for lorries
- with clip to attach the trigger
- Not suitable for use in installations that operate by gravity.

Code	Description
4430057413	1767.UR21 Pistola contalitri digitale adblue

Tecnical Features	
Minimum operating pressure	3bar
Operating temperature	-10°+60°
Input	3/4 bps-F
Supply	5-35 litres/min

## Adblue manual dispenser pistol



- **Manual pistol for cars and lorries**
- 15mm outlet with fixed outlet
- For cars and lorries thanks to the flow capacity of 80 litres per minute
- In polypropylene
- With pin to block the trigger

Code	Description
4430057410	1767.UR41 Pistola manuale adblue

Tecnical Features	
Peso Kg	0,26
Operating temperature	-10°+60°
Input	3/4 bps-F
Supply	80 litres/min

## Adblue rotary pump



- Polypropylene pump
- Suitable for the distribution of oil, diesel and Adblue in drums up to 200 litres
- Dispensing capacity: up to 60 litres/min
- With fixing union for stainless steel drums

Code	Description
4430057411	1792.PRP6 POMPA ROTATIVA ADBLUE

## ADBLUE KIT pump with digital pistol for drums of 200 litres



- Complete with stainless steel bracket for plastic drums of 200 litres
- With 230V electric pump
- Supply capacity: 30L/Min
- For cars
- The drum is not included in the kit
- For moving drums of 200 kgs, refer to Trolley for drums, our art. nr. 4700001700

Code	Description
4430057404	1770 URB4



## Tape measures anti-shock



NASTRO CON  
SUDDIVISIONE A NORME CE

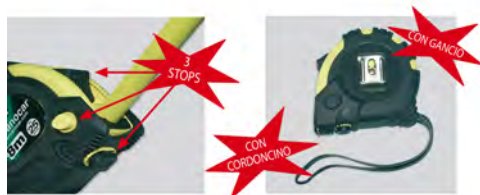

- Professional tape measures anti-shock.
- Full range of 2 to 10 meters.
- 3 with the locking systems of the tape.
- In two heights of tape; 19 mm and 25mm.
- With rear hook for belt clip and lanyard for transport or docking panel.

Code	Desc.	Length <i>m</i>	Tape height <i>mm</i>
4430050752	1016/2	2	19
4430050753	1016/3	3	19
4430050755	1016/5	5	25
4430050758	1016/8	8	25
4430050760	1016/10	10	25

## Measuring wheel 50 m



- Measuring wheel with steel tape painted yellow.
- Graduation in millimeters. 1 highlighted in red each decimal.
- Lightweight and impact resistant.
- Plastic body with rubber to absorb shock and protect against scratches and dust tape.
- With practical attack to hang the meter on the waist.
- Sturdy rope hook for easy transport.

Code	Desc.	Width <i>tape mm</i>	Tape leng. m.
4430051780	1059/50	13	50

## Misuratore telescopico fino a 5 m



GUAINA IMPERMEABILE  
PER LAVORARE ANCHE  
SU FONDO BAGNATO  
O SABBIOSO

- Misuratore telescopico a lettura diretta su nastro graduato con indicazione di misure interne ed esterne.
- Base a tenuta stagna con guaina impermeabile.
- Bloccaggio automatico di ogni asta a fine corsa.
- Fiala orizzontale e verticale per un corretto posizionamento dello strumento durante le misurazioni.
- Possibilita' di effettuare misurazioni ridotte grazie alla compattezza dello strumento.

Code	Desc.	Closed capacity cm	Capacity opening Max mm
4430049505	940 - 5	99	500

## Laser rangefinder – Measurer of distance 30 m



- Rangefinder – measurer of distance using laser technology; indication of the distance from 30 cm minimum to 30 metres maximum with instant indication of the measurement, memories, calculation functions of areas and volumes.
- Indicated for use by artisans and industries in many applications: plumbers, electricians, metal workers, air conditioning installers, finishing experts and plasterboard walls, carpenters, blacksmiths, etc.
- Visualisation of the measurement by the illuminated display on two lines, compact dimensions make it very practical and easy to use. Powered by two AAA batteries included as standard.
- Constructed in robust, impact-resistant material with soft protections against being dropped.
- Supplied as standard: batteries, transport and storage case.

Code	Desc.
4770006900	754



Technical Features	
Unit of Measure	metri
Automatic shutdown	Laser: 30 seconds – Equipment: 3 minutes
Functions	Distance, area, volume, min/max, duration of measuring
Precisione di misurazione	+/- 2 mm/30 m
Power supply	2 x 1.5V AAA batteries
Weight	90 g including batteries
Dimensions	40 x 110 x 24 mm
Storage temperature	From -20°C a +70°C
Laser wavelength	635 nm
Operating temperature	From -10°C a +40°C
Laser	Class 2 < 1 mW
Min/max measuring range	0,1/50 m

## Laser rangefinder – Measurer of distance 50 m



- Rangefinder – measurer of distance using laser technology; indication of the distance from 10 cm minimum to 50 metres maximum with instant indication of the measurement, memories, calculation functions of areas and volumes. Possibility of Bluetooth connection to transfer data to a Smartphone or computer.
- Indicated for use by artisans and industries in many applications: plumbers, electricians, metal workers, air conditioning installers, finishing experts and plasterboard walls, carpenters, blacksmiths, etc.
- Equipped with a 360° angle sensor for surveying horizontal and vertical measurements, Pythagorean functions for height calculations, min/max continuous measuring.
- Visualisation of the measurement by the illuminated display on three lines, compact dimensions make it very practical and easy to use. Powered by two AAA batteries included as standard.
- Constructed in robust, impact-resistant material with soft protections against being dropped.
- Supplied as standard: batteries, soft transport case

Code	Desc.
4770006530	740



Technical Features	
Weight	100 g including batteries
Dimensions	43 x 110 x 27 mm
Power supply	2 x 1.5V AAA batteries
Precisione di misurazione	+/- 2 mm/50 m
Laser wavelength	635 nm
Operating temperature	From -10°C a +40°C
Storage temperature	From -20°C a +70°C
Unit of Measure	m/ft/inch/_'/_"
Automatic shutdown	Laser: 30 seconds – Equipment: 3 minutes
Functions	Distance, area, volume, min/max, duration of measuring
Min/max measuring range	0,1/50 m
Laser	Class 2 < 1 mW



## Laser rangefinder – Measurer of distance 100 m



- Rangefinder – measurer of distance using laser technology; indication of the distance from 5 cm minimum to 100 metres maximum with instant indication of the measurement, memories, calculation functions of areas and volumes. Possibility of adding and subtracting measurements for the calculation of perimeters.
- Indicated for use by artisans and industries in many applications: plumbers, electricians, metal workers, air conditioning installers, finishing experts and plasterboard walls, carpenters, blacksmiths, etc.
- Equipped with Pythagorean functions for height calculations, min/max continuous measuring. Rear key insertable for taking measurements in corners.
- Visualisation of the measurement by the illuminated display on four lines, compact dimensions make it very practical and easy to use. Powered by two AAA batteries included as standard. Supplied with 1/4" threaded attachment (6.35 mm) for mounting on a support for accurate long distance measuring and out of doors.
- Constructed in robust, impact-resistant material with soft protections against being dropped.
- Supplied as standard: batteries, insertable key for corners, soft transport



Code	Desc.
4770007040	768

Technical Features	
Dimensions	51 x 124 x 27 mm
Weight	194 g including batteries
Precision di misurazione	+/- 1,5 mm/100 m
Power supply	2 x 1.5V AAA batteries
Storage temperature	From -20°C a +70°C
Unit of Measure	m/ft/inch/ ' / " "
Automatic shutdown	Laser: 30 seconds – Equipment: 3 minutes
Functions	Distance, area, volume, min/max, duration of measuring
Min/max measuring range	0,05/100 m
Laser	Class 2 < 1 mW
Laser wavelength	635 nm
Operating temperature	From -10°C a +40°C

8

## Double Meter m2



- Wood.
- Double graduation.
- Soft rust.
- Tested and red decimals.
- White yellow alternately.
- 3 mm thick.

Code	Desc.	N. sticks
4430044835	512	10



## Aluminum level



- Level professional aluminum. rugged and lightweight.
- Bubble horizontal and vertical clearly visible and protected by plexiglass. Vaporisation and waterproof.

Code	Desc.	Length mm
4430053720	1074/300	300
4430053730	1074/400	400
4430053740	1074/600	600
4430053750	1074/800	800
4430053760	1074/1000	1000

## Level magnetic aluminum



- Level professional aluminum. rugged and lightweight.
- Bubble horizontal and vertical clearly visible and protected by plexiglass. Vaporisation and waterproof.
- Magnetic base.

Code	Desc.	Length mm
4430053780	1075/400	400
4430053790	1075/600	600
4430053800	1075/800	800
4430053810	1075/1000	1000

## Level trapezoidal magnetic



- Level professional aluminum.
- Strong and light.
- Sharp profile for working in corners.
- Bubble horizontal and vertical clearly visible and protected by plexiglass. Vaporisation and waterproof.
- Magnetic base.

Code	Desc.	Length mm
4430053840	1076/500	500

## Magnetic pocket level



- Level professional abs with magnetic base.
- With three vials, clearly visible, protected. Vaporisation and waterproof.
- Light and practical.
- Minilivella Built-in magnetic and removable, for the leveling of wire.

Code	Desc.	Length mm
4430053880	1078	210

## Self-levelling laser level for measuring indoors



- Compact laser level with an excellent performance, ideal for measuring indoors. It projects single laser lines or horizontal and vertical laser lines at the same time, plus 5 laser points for plumb levelling and at the centre of three sides for perfect alignment. It self-levels autonomously within a drop of 3°.
- Indicated for use by artisans and industries in many applications: plumbers, electricians, metal workers, finishing experts and plasterboard walls, carpenters, blacksmiths, etc.
- Equipped with a levelling lock for tracking of inclined surfaces and laser lines activated autonomously. Complete with magnetic support for fixing directly on metal supports or temporary fixing on masonry via nails or wall plugs. Lower hole threaded with diameters of 1/4" and 5/8" for fixing on supports and optional tripods.
- the utilisation of the optional receiver, code 4770007060-770, the laser lines can be received up to a distance of 40 metres and they can also be utilized outdoors. Powered by four AA batteries that are included in the box/package.
- Supplied as standard: magnetic wall supports, batteries, transport and storage case.



Code	Desc.
4770007050	769

Technical Features	
Weight	550 g with batteries
Operating temperature	From 0°C to +45°C
Storage temperature	From -10°C to +70°C
Protection rating	IP 54
Dimensions	130 x 105 x 70 mm
Laser	Class 2 < 1 mW
Duration of the batteries	Approx. 10 hours
Power supply	4 x 1.5V AA batteries
Laser wavelength	635 nm
Self-levelling	+/- 3°
Measuring precision	2 mm/10 m

8

## Receiver for laser level 40 m and 100 m



- Laser level receiver for indoor and outdoor use, utilizable for all types of emitters, maximum reception distances: 40 m or 100 m.
- Utilised to increase the capacity of the levels, such as our models code 4770007050-769 or 4770007080-772 (supplied as standard) and for the utilization of the same under conditions of high luminosity and outdoors.
- Equipped with universal grip support also for the utilization on level staffs and various supports, upper and lateral magnet for application to metal supports.
- Powered by two AAA batteries that are included in the box.
- Supplied as standard: batteries and universal support.

Code	Desc.	Portata
4770007060	770	40 m
4770007070	771	100

Technical Features	
Maximum reception distance	40 m - 100 m
Power supply	2 x 1.5V AAA batteries
Dimensions	60 x 110 x 23 mm
Weight	145 g



## Rotating, self-levelling laser level for outdoor use 100 m



- Compact laser level, easy to use with a great performance; ideal for indoor and outdoor use, with a rotating laser tower and vertical projection and upper vertical projection of the plumb level. The level self-levels automatically within a level drop of 4°.
- Indicated for use by artisans and industries in many applications: plumbers, electricians, metal workers, finishing experts and plasterboard walls, carpenters, blacksmiths, in the building industry and earth moving industry, for laying tubing, etc.
- Receiver supplied as standard for distances up to 100 metres, support with 5/8" threaded hole for use on walls and for fixing on optional tripods and remote control to change the functions from a distance of up to 40 metres,
- The motorized rotary tower permits selecting each function, such as: point, adjustable scanning and rotation and 360° rotation. The equipment can be mounted either horizontally or vertically for each type of tracking. Possibility of utilizing a levelling lock for tracking of inclined surfaces.
- Equipped with all security devices against errors or instable mountings. The equipment disengages automatically if there are levelling errors or movements during use.
- Powered by an internal rechargeable battery, battery charger included in the standard supply. Batteries for powering the receiver and remote control are included in the supply
- Standard supply: laser receiver 100 metres, remote control, universal support, power feed battery/battery charger, case for transport and storage

Code	Desc.
4770007080	772

Technical Features	
Weight with mounted support	1,3 Kg
Dimensions with mounted support	130 x 160 x 145 mm
Protection rating	IP 66
Selectable functions	Punto, scansione, rotazione completa
Levelling type	Orizzontale e verticale
Maximum capacity	100 metri con ricevitore
Recharge time	Circa 5 ore
Durata carica batteria	Circa 12 ore
Power supply	Pacco batterie ricaricabili
Laser wavelength	635 nm
Laser	Classe 2 < 1 mW
Self-levelling	+/-5°
Measuring precision	+/-1,5 mm/10 m

**Light tripod h. 120 cm**

- Telescopic tripod manufactured entirely in aluminium, compact, stable and robust; for utilization with any measuring instrument and laser tracing instrument. Minimum height 57 centimetres, maximum height 122 centimetres.
- It can be utilised inside and outside thanks to the stable metal and rubber tips, precise and fluid movement via the handle, joints in impact-resistant material and precise movement.
- Can be easily collapsed and transported thanks to the reduced dimensions. Equipped with a spirit level for perfect levelling. 5/8" male thread attachment.

Code	Desc.
4770007090	773

8

**Heavy tripod h. 300 cm**

- Extremely robust telescopic tripod designed for demanding jobs above all outdoors. It can be utilised for any measuring instrument or laser tracking instrument; minimum height 129 centimetres, maximum height 295 centimetres.
- It can be utilised indoors or outdoors thanks to the stable metal and rubber tips, precise and fluid movement via the handle, joints in impact-resistant material and the precise movement. It has extreme stability in strong, windy conditions thanks to the lower fixing cross and rapid double blocking of the feet.
- It can be easily collapsed and has a robust profile construction in aluminium with steel feet. Supplied with a shoulder strap for transportation.

Code	Desc.
4770006890	753

## Telescopic level staff 4 metres

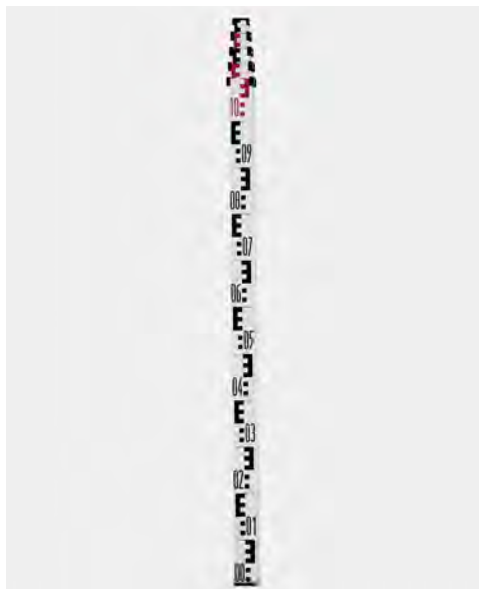

- Telescopic level staff in aluminium constructed for utilisation with laser levels and site levellers.
- Stable, robust, with clearly visible indications, excellent for demanding professional use. Closed it measures 1.19 metres and it can be extended at any level up to the maximum height of 4 metres.

Code	Desc.
4770006850	749

## Laservision glasses



- Specific glasses to improve the visibility of red laser rays even in unfavourable light conditions or at great distances
- The lens of these glasses improve the contrast between the laser lines and the rest of the view, thereby greatly improving the perception of the laser lines.

Code	Desc.
4770007100	774



## Digital levels with laser pointer



- Electronic levels with digital indication of the degrees of angle with an acoustic signal on reaching 0°, 45°, 90°, 135° and 180° to facilitate the utilization. Extension of the level utilizing the lateral laser point, with magnets in the lower part.
- Indicated for utilization by carpenters, window installers, for finishes, plasterboard walls, electricity lines and water lines, etc. Construction of the structure in aluminium with a graduated base, large illuminated display that automatically flips for overhead measurements. ¼" threaded hole (6.35 mm) in the lower central area for assembly on supports and tripods.
- Self-calibrating function for automatic recalibration of the angle sensor. Measuring precision: +/- 0.05° at 0°; +/- 0.1° at 90°; +/- 0.2° from 1° to 89°. Level precision: +/- 0.5 mm/m. Powered by two AAA batteries that are included in the box.
- Supplied as standard: soft transportation bag and batteries to make it function.

Code	Desc.	Length cm
4770007010	765	60
4770007020	766	120

8

## Simple precision squad



- Easy squad in hardened and ground steel.
- Accuracy according to DIN 875 / II.
- **Applications:** plumbing, blacksmithing, carpentry, maintenance.
- Suitable for commissioning team profiles, pipes, etc.

Code	Desc.	Measures
4430052800	1070/75x50	75x50
4430053000	1070/150x100	150x100
4430053100	1070/200x130	200x130
4430053500	1070/500x330	500x330

## Precision squad at cap



- Easy squad in hardened and ground steel.
- Accuracy according to DIN 875 / II.
- **Applications:** plumbing, blacksmithing, carpentry, maintenance.
- Suitable for commissioning team profiles, pipes, etc.

Code	Desc.	Measures
4430052000	1069/75X50	75x50
4430052100	1069/100x70	100x70
4430052200	1069/150x100	150x100
4430052300	1069/200x130	200x130
4430052400	1069/250x160	250x160
4430052500	1069/300x200	300x200
4430052600	1069/400x265	400x265
4430052700	1069/500x330	500x300

## Endoscopic inspection videocamera 6 mm – 1.5 m



8

- Endoscopic videocamera with fibre optic sensor, impermeable camera head (IP68) 9 mm diameter, 3.5" colour display for clear and easy inspection of inaccessible zones. Possibility of taking video or photos in JPEG and AVI.
- Can be utilized in all work sectors for internal inspection of parts even with restricted entries: plumbers, electricians, building sector, mechanical sector for the internal inspection of engines and mechanical parts.
- Equipped with LED illumination of the focused zone. Possibility of connecting external monitors via the TV-Out socket, recording function of photos and videos for successively analyzing and visualizing, SDHC additional memory with fast formatting, direct transmission of data to a PC via USB cable.
- Practical handgrip controls using a finger: 1.5x digital zoom in increments of 10%, rotation of the image on the monitor to 180°. DOF: depth of field from 1 to 6 metres. "Mirror" function to correct the image reflected in a mirror.
- Power supplied by rechargeable Ion Lithium batteries. Possibility of substituting the standard sensor with others of different diameters and lengths, depending on requirements.
- Supplied as standard: handgrip with monitor and integrated controls, sensor 1.5 metres in length and 6 mm diameter, rechargeable battery pack, 220V power feed/battery charger, USB/REC cable, CD-Rom with software for PC, 4GB micro SD card, video connection cable, transport and storage case.

Code	Desc.
4770006920	756

Tecnical Features	
Weight including batteries (kg)	0,56
Storage temperature	From -10°C a +60°C
Operating temperature	From 0°C a +45°C
Tempo di utilizzo con una carica	Approx. 4 hours
Recharge time	Approx. 4 hours
Power supply	Ion Lithium battery pack
Connectors	Micro-SD/Analogic video
Memory	SDHC card 8 GB maximum
Outlet port	Mini USB
Illumination	10 adjustable levels
Zoom	1.5x digital in increments of 10%
Formato immagini/Image format	JPEG/AVI
Display resolution	320 x 240 pixel
Focusing distance	From 1 a 6 cm
Videocamera resolution	640 x 480 pixel
Screen	3,5" colour TFT
Videocamera and sensor protection rating	IP68

## Endoscopic inspection videocamera 9 mm – 1.5 m and 10 m



- Fibre optic, endoscopic videocamera with the same characteristics as our model code 4770006920, but equipped with a 9 mm videocamera for more detailed and precise images and a sensor with a greater diameter, more robust and rigid, suitable for greater distances or numerous curvatures.
- Lengths of the sensors available: 1.5 m or 10 m.
- The standard equipment has been increased by the addition of: hook, magnet and mirror for mounting only on the 9 mm videocamera, and a reinforced metal tip for the protection of the videocamera during use in uneven, difficult areas

Code	Desc.	Lunghezza sonda
4770006930	757	1,5 m
4770006940	758	10 m

## Accessories for endoscopic videocameras

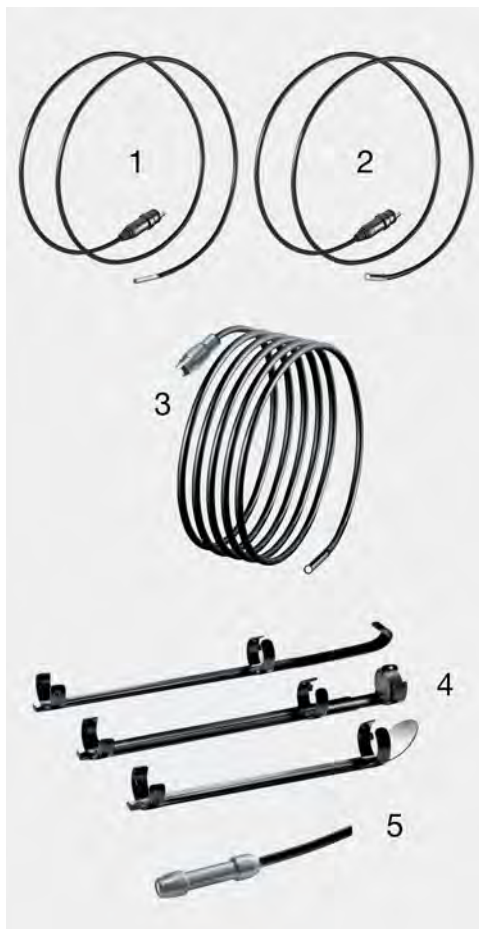

- Accessories to repair, modify or increase the range of our endoscopic inspection cameras. Different lengths and diameters of sensors can be mounted on the standard handgrip

Code	Desc.	Article	Photo
4770006950	759	Sonda diametro 6 mm lunghezza 1,5 m	1
4770006960	760	Sonda diametro 9 mm lunghezza 1,5 m	2
4770006970	761	Sonda diametro 9 mm lunghezza 10 m	3
4770006980	762	Kit gancio, magnete e specchio (solo per sonde da 9 mm)	4
4770006990	763	Punta di rinforzo in metallo (solo per sonde da 9 mm)	5



## Laser tracer



- **Precision optical instrument** for easy commissioning and lead allineatura of all objects to be fixed.
- The plotter, applied to the wall or to the floor, generates a **laser light beam is clearly visible** that allows to fix in a perfectly aligned with any object: wall coverings, furniture, electrical, plumbing, air conditioners, etc..
- Possibility to draw even on two adjacent walls, for leveling on the corners.
- The swing base and rotating on 360 ° allows you to draw lines in different angles, perpendicular and oblique.
- Can be fastened to the wall using steel nails or through the special double-sided adhesive strips provided as replacement 4,430,051,060.
- Thanks to the **adhesive strips supplied**, the laser tracer can be applied in a simple, clean and delicate on different surfaces: wallpaper, painted walls, plaster finish, plasterboard, tiles, glass, wood etc.
- Runs on two AA batteries AA, supplied as standard and as replacement 5,120,001,020.
- **Standard equipment:** laser ray, 2 AA batteries; 10 strips bioadhesive 3m; instruction manual.

Code	Desc.
4430053600	1071

Tecnical Features	
Weight	298 g
Dimension mm	105 lu.x94 h.x97 la.
Laser class	2
Lunghezza d'onda	635 nm
Precisione	± 0,8 mm/1m
Raggio d'azione	18m

8

## Presence detector (Metal detector)



- Electronic instrument for the detection of wood, metal pipes and electrical cables under walls and floors.
- Display with user guidance, which allows you to use the device easily and safely.
- **Applications:** carpentry, joinery, electrical, plumbing and heating, maintenance.
- **Features:** electronic recognition of wooden beams and cross beams bricked walls dry (plasterboard, wood paneling). Metal detection in walls of stone, concrete, plasterboard, wood panels. Localisation of live wires embedded in the plaster or under electric panels of wood and other non-metallic coatings.
- Possibility of identifying metal objects up to a maximum depth of 10 cm. Occurrences of wood up to 3 cm, copper pipes up to a maximum of 5 cm and power cables to 4 cm.
- Operation with 9V our code 512 00 01040, equipped série.

Code	Desc.
4430053890	1079

## Plotting probe



- Hardened steel and nickel.
- Straight tip and bent.

Code	Desc.
4430044990	527



## Retractable pen to trace



- Metal high resistance.
- Format pen clip.
- Replacement tips  $\varnothing$  2mm carbide.

Code	Desc.	Content
4430045060	534	(PEN + A TIP)
4430045062	534/P	(TIP EXTRA)

## Penna a tracciare in metallo duro



- Penna a tracciare in metallo duro.
- La struttura completamente in acciaio
- Conferisce all'utensile la massima robustezza e durata nel tempo.



Code	Description	Leng. mm	Content
4430056560	1766	165	Penna a tracciare
4430056565	1766P	-	Punta di ricambio $\varnothing$ 16mm

## Gessi in Steatite per Marcatura

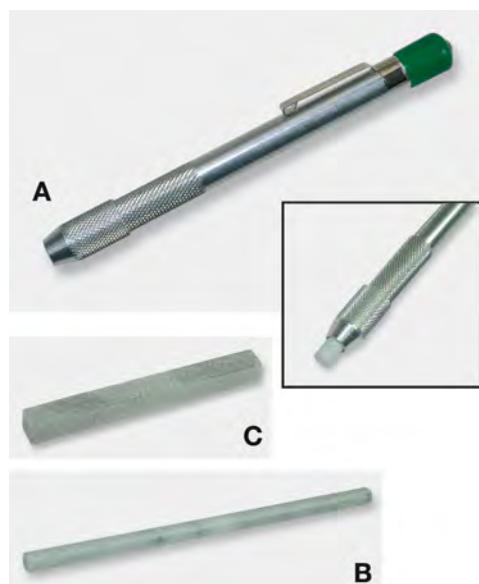

- Gessi in steatite.
- Ideali per scrivere e tracciare su: lamiera d'acciaio, ferro, pietra, calcestruzzo e legno.
- Da utilizzare anche per la marcatura di superfici bagnate.
- Settore di utilizzo: carpenteria, fabbri, serramentisti.

Code	Desc.	Characteristics	Photo
4430055005	1121	PENNA PORTA GESSO TONDO	A
4430055010	1122	GESSO TONDO	B
4430055015	1123	GESSO QUADRATO	C

## Thickness Gauges



- Steel with metal housing .
- Blade length 100mm.

Code	Desc.	N. Blades	Capacity
4430027200	338-8	8	0,05 ÷ 0,50 mm
4430027210	338-13	13	0,05 ÷ 1,00 mm
4430027220	338-20	20	0,05 ÷ 1,00 mm

### Precision caliper tip



- Extra robust Execution.
- A square section.
- Straight tips hardened steel.
- Suitable for body transformation, and users processing of sheet metal in general.

Code	Desc.	Diameter capacity
4430044844	513-250	200 mm

### Screw pitch gauges

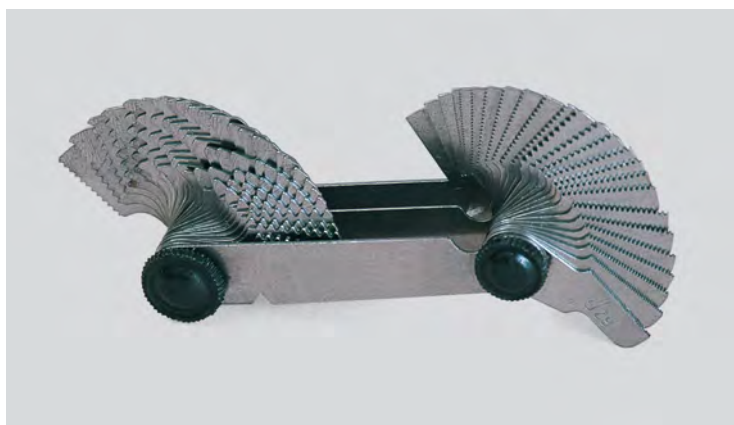

- Steel metal enclosure.
- 52 blades.
- For distance metric, UNC, UNF, Whitworth and gas.

Code	Desc.
4430027100	337

8

### Gauge swabs for holes

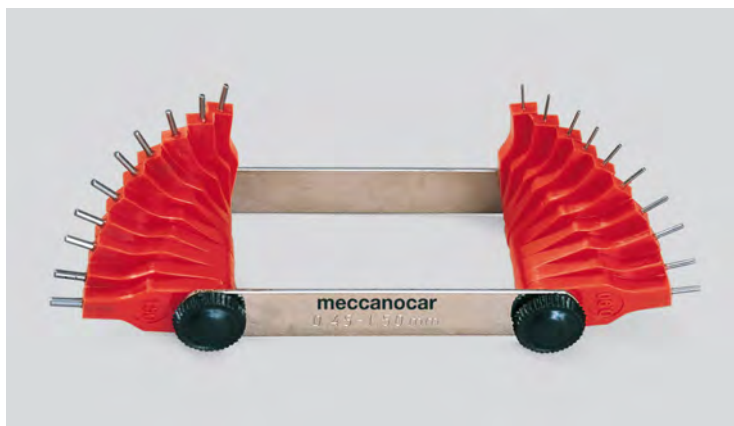

- With steel pins.
- Carburetor, for micromechanics.

Code	Desc.	Capacity
4430046032	637-1	0,45 ÷ 1,50 mm
4430046033	637-2	1,50 ÷ 3,00 mm

### Depth gauge

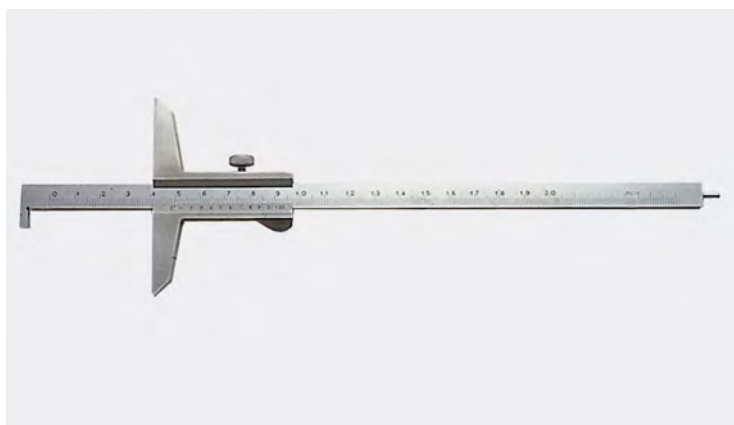

- Hardened stainless steel, scale matt chrome, dual scale (front and back), end needle and team, in case.
- Twentieth.

Code	Desc.	Capacity	Hooks mm
4430027050	336/5	0-200 mm	80

## Caliber precision



- Monoblock of hardened steel.
- Scale matt chrome.
- Caliper compound.
- Locking lever.
- Reading metric and inch.

Code	Desc.	Capacity	Hooks mm	Lettura mm - inch
4430027000	336	0 - 135 mm	45	0,05 - 1/128"

## Twentieth caliber high precision steel



- Monobloc stainless steel.
- Scale matt chrome.
- Caliper compound.
- Locking lever.
- Reading metric and inch.

Code	Desc.	Capacity	Hooks mm	Lettura mm - inch
4430027010	336/1	0 - 160 mm	40	0,05 - 1/128"

## Caliber high precision dial



- Monobloc hardened stainless steel.
- Protected rack.
- Square measure.
- The dial allows a more rapid and accurate.

Code	Desc.	Capacity	Hooks mm	Lettura mm - inch
4430027040	336/4	0 - 200 mm	40	0,02 - /

## Centesimal gauge high precision digital



- Hardened stainless steel.
- Square Measure.
- Reading 0.01mm.
- Accuracy  $\pm 0.02$  mm.
- Repeatability 0.01 mm.
- Printer output.
- Conversion mm / inch.

Code	Desc.	Capacity	Hooks mm	Lettura mm - inch
4430027030	336/3	0 - 155 mm	40	0,01 - 1/1000"

## Micrometers grads for outdoor



- High precision.
- DIN 863.
- Reading 0.01mm.
- Arco chrome.
- Contact width  $\varnothing$  6.5 mm.
- Drum  $\varnothing$  18.
- Locking lever and wooden case.

Code	Desc.	Capacity
4430044910	519-0-25	0 ÷ 25 mm
4430044920	520-25-50	25 ÷ 50 mm
4430044922	520-50-75	50 ÷ 75 mm
4430044923	520-75-100	75 ÷ 100 mm
4430044925	520-125-150	125 ÷ 150 mm

## Micrometro centesimale per interni



- Micrometro con becchi per misurazioni di interni DIN 863 con lettura 0,01 mm.

Code	Desc.	Capacity
4430049510	941 - 5 - 30	5 - 30 mm
4430049515	941 - 25 - 50	25 - 50 mm
4430049520	941 - 50 - 75	50 - 75 mm
4430049525	941 - 75 - 100	75 - 100 mm

8

## Squadra graduata in alluminio

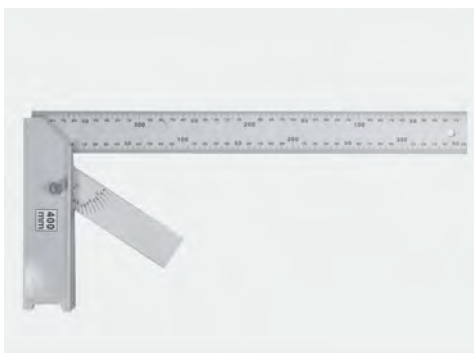

- Base in alluminio presso-fuso e asta in acciaio al carbonio.
- Con stampa millimetrata su entrambe i lati dell'asta.
- Asta inserita nella base per la misurazione degli angoli.
- Particolarmente indicata nel settore legno e meccanico.

Code	Desc.	Lunghezza asta-base
4430056610	1771-400	400/180

## Falsa squadra-regolabile



- Impugnatura in alluminio, lama in acciaio.
- Con sistema di bloccaggio manuale.
- Lama con asola di scorrimento.
- Consente il controllo degli angoli.
- Per fabbri e carpentieri

Code	Desc.	Length mm
4430056590	1769-250	250

## Pump pressure / depression



- The vacuum pump serves for the control and calibration of the various parts of an engine and hydraulic systems of a vehicle. In addition, most of the work will be done with the engine off. the pump works in both pressure position and in that of depression.
- For all workshops and repair shops generally.
- Supplied in plastic case with numerous accessories and illustrated booklet for the tasks you can perform.

Code	Desc.
4770002140	214



## Try radiators



- Device for controlling pressure of the cooling system of cars and trucks.
- It allows you to detect leaks of the cooling system and faults: defective sleeves, loose clamps, leaking seals water pump, radiator, head gasket burned, or poorly fitted.
- It equipped as standard with all caps for cars and trucks.

Code	Desc.
4480000400	796

**ACCESSORI FORNITI DI SERIE:**

MODELLO	CODICE MECCANOCAR	RIF. ORIGINALE	APPLICAZIONI	MODELLO	CODICE MECCANOCAR	RIF. ORIGINALE	APPLICAZIONI
	448 00 00665	416.65	MERCEDES Ø 46 mm		448 00 00605	416.05	FIAT GROUP - PSA RENAULT - NISSAN - MINI VOLVO ROVER
	448 00 00670	416.70	FIAT - SUZUKI - TOYOTA - MITSUBISHI		448 00 00610	416.10	VW GROUP - FORD - OPEL SAAB - CHEVROLET
	448 00 00680	416.80	MAZDA - FORD VOLVO		448 00 00624	416.24	BMW Ø 53 mm
	448 00 00685	416.85	BMW Ø 51 mm		448 00 00630	416.30	FIAT GROUP - OPEL - SAAB
	448 00 00700 + 448 00 00668	416.66 + 416.68	TAPPI A BAIONETTA		448 00 00635	416.35	VW GROUP - PORSCHE
	448 00 00673 + 448 00 00668	416.73 + 416.68	TAPPI A BAIONETTA		/	416.40	FORD
	448 00 00673 + 448 00 00675 + 448 00 00668	416.73 + 416.75 + 416.68	TAPPI A BAIONETTA		448 00 00645	416.45	MERCEDES Ø 63 mm
	448 00 00673 + 448 00 00676 + /	416.73 + 416.76 + 416.78	TAPPI A BAIONETTA		448 00 00655	416.55	SMART - PORSCHE

**ACCESSORI FORNIBILI A RICHIESTA:**

MODELLO	CODICE MECCANOCAR	RIF. ORIGINALE	APPLICAZIONI
	448 00 00664	416.64	TAPPO PER BAIONETTA Ø 48 mm
	448 00 00750	416.20	POMPA DI PRESSIONE MODELLO PRECEDENTE

## Fill radiator to depression

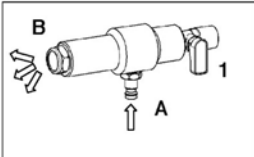
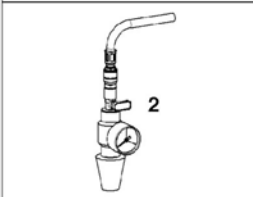

- Tool for rapid filling of the radiator and the cooling system of cars, motorcycles and trucks.
- The system works in depression, and allows the rapid and total filling of the cooling circuit, without the need to set in motion the vehicle several times during the operation.
- When a cooling circuit is filled with liquid, they are formed of the air bubbles that shall be completely removed, otherwise, you will have the partial filling that exposes the vehicle to the risk of overheating of the motor. To avoid this you need to put in motion the vehicle several times, and then proceed to subsequent refills.
- With riempiradiatori a vacuum is created inside the circuit, which allows a rapid and total filling, in a short time and without problems.
- The vacuum is generated with the use of compressed air.
- It is a suitable tool for cars, motorcycles and trucks.
- The kit provided 3 cones of different sizes, to accommodate different pipe unions radiator.
- The tool operates on a circuit previously emptied of the liquid, and it also allows the
- leak test.
- **Use of this tool greatly reduces the time and ensures a high quality work performed.**

	<p>Svuotare completamente il circuito dal liquido. L'attrezzo funziona con il radiatore vuoto. Aprire il riscaldamento al massimo per non avere strozzature. Collegare il GENERATORE DI VUOTO alla rete dell'aria compressa ( 6 - 10bar ). Aprire il rubinetto 1 e controllare il regolare funzionamento: A aspirazione B scarico Controllare che lo scarico sia libero. L'ostruzione dello scarico mette in pressione il radiatore, con gravi danni per lo stesso.</p>		<p>Introdurre il GRUPPO DI MISURA nel bocchettone del radiatore. Collegare il GENERATORE DI VUOTO. Aprire il rubinetto 1 Aprire il rubinetto 2 Controllare sul vuotometro il valore di vuoto ( zona verde ad ago stabilizzato ). Chiudere il rubinetto 2 Chiudere il rubinetto 1 Scollegare il generatore di vuoto. Se dopo circa 15 secondi l'ago non si è mosso l'impianto è a tenuta, procedere quindi all'operazione di riempimento. È normale che si schiaccino i manicotti in gomma per effetto della depressione.</p>
	<p>Montare sul GRUPPO DI MISURA il cono in gomma adatto per il radiatore da riempire.</p>		<p>Introdurre il TUBO DI PESCAGGIO nel liquido di raffreddamento e collegarlo al GRUPPO DI MISURA. Aprire il rubinetto 2 Quando il vuotometro sale a "0" il radiatore è riempito.</p>

Code	Desc.
4430055930	1538

Tecnical Features	
Adapter	Ø 16 - 33 mm Ø 23 - 41 mm Ø 34 - 52 mm
Press. Eserc.	from 5,5 to 12,0 bar.
Max air consumption	100 l/min to 6 bar.
Air connection	1/4
Temperature	from -20° to +50°C.

## Kit seal control



- To control the volume of CO2
- Special pump for the control of the heads of all the internal combustion engines water cooled.
- Thanks to the contrast fluid (which changes color in case of leakage) it is possible to detect cracks and leaks on cylinder heads and on the gaskets tested on the engine block.
- The device is provided for the liquid leak detection.
- With instructions for use.

Code	Description
4770000080	8 COMPLETE KIT

Spare Parts	
Code	Description
4770000081	1.8 FLUID CONTROL
4770000082	8.2 CLEANING FLUID

## Thickness gauge plates valves



- High precision.
- Reading 0.01mm.
- Depth 50 mm.

Code	Desc.
4640000100	164

Spare Parts			
Article	Code	Description	
REPLACEMENT COMPARATOR 0-10 mm	4640000200	165	

## Electronic torque measurer



- Electronic device to transform a ratchet wrench or a traditional spanner in a precise dynamometric torque wrench
- Interior/exterior square attachment
- Automatic calibration
- Zeroing of the setting when switching on
- Visual and acoustic indication on reaching or exceeding the preset torque
- Tracking/peak mode: visualizes the torque force utilised until the required torque is reached
- Precise measuring: +/- 2% tolerance
- 50 memories
- Batteries and DIN EN ISO 6789 test certificate included
- Supplied in a plastic case

Code	Desc.	Attachment	Torque Nm / Lb.ft	Inserted battery	Dimensions BxLxH mm
4430058010	1779- 6-30 Nm	1/4	6-30 Nm / 4,4-22,1 Lb.ft	1 x 5120001130-CR 2032	122x190x64
4430058020	1779 - 27-135 Nm	3/8	27-135 Nm / 19,9-99,6 Lb.ft	1 x 5120001130-CR 2032	122x190x64
4430058030	1779- 40-200 Nm	1/2	40-200Nm / 29,5-147,5 Lb.ft	1 x 5120001130-CR 2032	122x190x64
4430058040	1779- 100-500 Nm	3/4	100-500 Nm / 73,8-369 Lb.ft	2 x 5120001020-LR6-AA	156x110x80
4430058050	1779-200-1000 Nm	3/4	200-1000 Nm / 147,6-738 Lb.ft	2 x 5120001020-LR6-AA	156x110x80

## Torque wrench Standard



- Keys made of quality steel for heavy work involving ensuring precise and constant tightening.
- Calibration quick and practical thanks to a retractable lever housed in the handle. Pulled the lever is rotated until the chosen couple.
- Tightening with constant action, a strong shot, noticeable both acoustically and mechanically is reached, the setting level.
- Releasing the key resets automatically.
- Sliding square drive for right and left tightening.
- Equipped with 4 scales: Nm, Kgm, Ibf.in, Ibf.ft.
- With plastic case.
- Calibration certificate with referibilità sit.

Code	Desc.	Range Nm	Range kgm	Control panel attachment	l.mm	Weight gr.
4430026940	335-10-60	100-600	10-60	3/4"	880	5500
4430026950	335-20-100	200-1000	20-100	1"	1030	9700



## Torque wrench with goniometer



- Operation Snap and protractor head.
- Ability to perform tightenings references in pairs and degrees with a single tool.
- Staircase nm and references in Ft / lb or kgm.
- Made according to the norms bs 6703/88 and GGG-W-686.
- Accuracy  $\pm 4\%$ .
- Each key is tested according to the ISO / BS and accompanied by a numbered certificate of control.
- Only for right-handed screws.
- \* For serragi right and left.

### ESEMPIO DI FUNZIONAMENTO DEL GONIOMETRO



1. IMPOSTARE 0° SULLA SCALA GRADUATA AD INCREMENTI DI 15° (FIG. 1)
2. INSERIRE LA BUSSOLA SUL DADO ED ALLINEARE LA POSIZIONE DELLA CHIAVE (CON UN DADO O CON UN ALTRO RIFERIMENTO)
3. RUOTARE, IN SENSO OPPOSTO A QUELLO DI SERRAGGIO, LA CHIAVE FINO A RAGGIUNGERE IL VALORE ANGOLARE RICHIESTO (FIG. 2)
4. GIRARE ORA LA CHIAVE IN SENSO ORARIO FINO ALLA POSIZIONE ORIGINALE (SOLO PER VITI DESTROSE)

Code	Desc.	Capacity Nm	Turn handle	Scala manico	Length mm	Weight Kg.	Control panel attachment
4430049443	933 - 0,5 - 2,5	5 - 25	2 Nm	0,4 Nm	270	0,49	3/8"
4430049444	933 - 2 - 11	20 - 110	14 Nm	1 Nm	365	0,83	3/8"
4430049445	933 - 4 - 21	40 - 210	10 Nm	1 Nm	470	1,35	1/2"
4430049446	933 - 7 - 35	70 - 350	70 Nm	5 Nm	630	2,45	1/2"
4430049448	933 - 14 - 70	140 - 700	70 Nm	2,5 Nm	1065	6,00	3/4"
4430049950	975 - 7 - 35*	70 - 350	70 Nm	5 Nm	630	2,45	1/2"

8

## Torque wrenches



- With reversible ratchet 72 teeth.
- Turning angle of just 5°.
- Key setting in seconds with a simple movement of the cursor.
- Scale easy to read protected by a window with magnifying effect.
- Double signal at torque: acoustic trigger and effort decrease.
- Accuracy of tightening UNI EN 26789/1995.
- Calibration certificate traceable to sit.

Code	Desc.	Payload Nm	Portata	Attachment	l.mm	Weight gr.
4200090600	10-60	10-60	1-6 kgm	1/2"	380	1000
4200091000	20-100	20-100	2-10 kgm	1/2"	450	1200
4200092000	40-200	40-200	4-20 kgm	1/2"	450	1200
4200093000	60-350	60-350	6-35 kgm	1/2"	590	1450



## Protractors



- Protractors Universal tightening torque plus angle.
- Usable with a torque wrench waving on the bolts to a torque of initial and subsequently tightening with rotation.
- This system allows you to tighten the bolts to the limit of the yield guaranteeing a traction force more 'constant.
- Square drive 1/2 ".
- Index rubbed with nut and rubber ring for easy setting in any position.
- Auction anchor flexible alligator clip or magnet.

Code	Desc.	Panel	Tipo bloccaggio
4430044460	497	1/2"	PROTRACTOR WITH MAGNET
4430044465	497/1	1/2"	PROTRACTOR WITH CLAMP

## Rilevatore of angoli digitalis 60 cm



- Goniometer with digital angle indication and overlapping arms equipped with both horizontal and vertical spirit levels.
- Indicated for accurate measuring in the building field, metal and wood construction fields, installing of windows, constructions in plasterboard, finishing, constructions of all types.
- Equipped with bevel square that can be lifted with indication of the degrees, front and rear illuminated display, recall memory of the measurements, removable protractor to extend the mobile arm, automatic calculation of the angle bisector.
- Precision of the angle measurement: +/- 0.2°. Precision of the level: +/- 0.25 mm/60 cm. Powered by two AA batteries that are included in the box.
- Supplied as standard: soft transportation bag.



Code	Desc.
4770007030	767

## Goniometro a quadrante



- Bracci in alluminio incernierati con bloccaggio a vite.
- Lettura diretta in gradi sul quadrante.
- Capacita' di lettura 0-180°.
- Doppia fiala acrilica.
- Punte asportabili in acciaio temperato per uso compasso, per riporti e tracciature.
- Lunghezza bracci 60 cm.
- **IDEALE PER:**
  - Rilevare inclinazioni di scale, Tralicci inclinati etc.

Code	Desc.
4430049475	936



BRACCI AFFIANCATI

## Support gauge holder



- Support magnetic gauge holder.
- Consisting of 3 steel arms with adjustable spring for fine adjustment.
- With prismatic base.
- With toggle switch for switching off the magnet.
- Tool and particularly used in the workshop for the control of the surfaces.
- **Delivered without comparator.**
- For use see n / s dial indicator art. 4640000200

Code	Desc.	Payload kg	Stroke mm
4430055925	1536	60	-
4640000200	165	-	10

## Torque multipliers

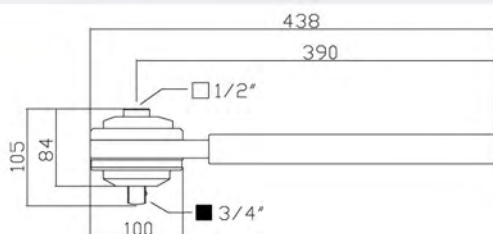

- Force multipliers for cars, vans and trucks.
- Designed to allow tightening with high torque, even in tight spaces or difficult to access, with security protection against overload.
- Light work when you need to tighten or loosen the screw connections difficult with high torques.
- The clamping forces are transmitted with extreme ease and with the utmost precision.
- The gears are built to a high standard of accuracy and with high quality materials.
- To avoid compromising the internal gear, the multiplier should always be used with a torque wrench, in which both screwing unscrewing.
- Supplied in convenient case abs transport, reaction bar and framework out parts.
- For tightening right and left, where of course the torque wrench used to have this feature.
- Equipped with a graduated scale (0-360 °), in order to make the tightenings in degrees.
- Do not use force multipliers impact tools.
- Their practicality and ease in transport enables use to those who must perform breakdown operations.
- Scope: generic workshops and authorized vehicles, industrial vehicles and body transformation, repair and body shops transformation special vehicles, truck drivers, private bus companies, companies municip. sanitation and public transportation, construction, agriculture.

Code	Desc.	Ratio	Max. torque input	Max. torque Output	Attachment □	Attachment	L mm	Diam. mm	H mm	Weight Kg.
4770005300	600	1:6 1:5,4	280 Nm	1680 Nm	1/2"	3/4"	128	110	105	4,9

## Force multiplier for truck wheel nuts



- Practical tools to loosen and / or tighten the bolts and / or nuts of the wheels of trucks, buses, tractors.
- Suitable for hauliers, farmers, roadside assistance.
- Thanks to the gear ratio 1:58 (1 kg = 58kg), the kit allows you to work without any effort on the bolts loosening.
- Supplied in case.
- Note. use compasses reinforced long series n / s Article 00 ..... 443 - 205.
- Max 3200 nm

Code	Desc.
4770005315	615



### COMPOSIZIONE DEL KIT

1 MOLTIPLICATORE DI FORZA CON RAPPORTO DI TRASMISSIONE 1:58  
 1 MANOVELLA CON ATTACCO 1"  
 1 PROLUNGA LG.200MM ATTACCO 1"  
 1 BUSSOLA RINFORZATA MISURA 32 ATTACCO 1"  
 1 BUSSOLA RINFORZATA MISURA 33 ATTACCO 1"  
 1 VALIGETTA IN MATERIALE TERMOPLASTICO L38 CM X H21 CM X S 13,5 CM

### ISTRUZIONI PER LO SMONTAGGIO

1 )prendere la bussola idonea ( nel kit sono presenti la misura 32 e la 33)  
 2 )inserire la manovella e la bussola sul moltiplicatore di forza,cominciare a girare in senso antiorario in modo da allentare con il minimo sforzo il bullone avendo cura di far appoggiare il piede di sostegno del moltiplicatore ad un altro bullone. In questo modo si riesce a allentare la presa con il minimo sforzo  
 3 ) una volta allentato il bullone,togliere il moltiplicatore ,togliere la bussola e montarla sulla prolunga insieme alla manovella e ultimare l'operazione,procedere di seguito su tutti i bulloni  
 Per il montaggio: procedere in senso inverso

## Optical densimeter at refraction



Code	Description
4770000800	80 - Optical densimeter

- Hydrometer optical refraction.
- Suitable for all workshops.
- Multiple applications: precision instrument allows the immediate control of the density of battery acid, the freezing point of the coolant, the freezing point of the washer fluid.
- Scale antifreeze liquid from 0 ° C to -50 ° C.
- Scale washer fluid from 0 ° C to -40 ° C.
- Scale liquid state of battery charge from 1.10 to 1.40 kg / l, with indication of the battery status.
- Consisting of a rubber grip, a regulator of focus and a monocular.
- It is offering tube for fluid sampling, one vial of distilled water and a mini screwdriver to carry out the operations of calibration, of a soft cloth for the cleaning of the prism.
- Instruction sheet inside.

### INSTRUCTIONS FOR USE

- **A-** Once calibrated the instrument, place the prism with the appropriate tube 2-3 drops of liquid that you want to examine and close the lid.
- **B-** Leave the liquid on the prism for approximately 30 seconds.
- **C-** Point in the hydrometer to the light source. And look in the monocular the scale, by reading the value on the line of demarcation.
- **D-** after use to clean carefully with a soft cloth and place the tool into the protective case.

8

## Antifreeze densimeter



- For checking and restoration of the anti-freeze mixture consisting of water mixed with antifreeze or any type of liquid for sealed circuits.
- Provided with thermometer and relative scale to compensate for the read values between density and temperature of the liquid at the time of reading.
- \* Glass Replacement 795.

Code	Desc.
4480000300	795
4480000310	795/1*



## Antifreeze densimeter professional



- Check and establish the exact temperature of the antifreeze.
- The mechanisms suction hinder the formation of bubbles or backflow.
- The measurement is independent of the cooling water temperature and the concentration of antifreeze liquid.
- Tolerance  $\pm 1\%$ .

Code	Desc.
4480000800	800

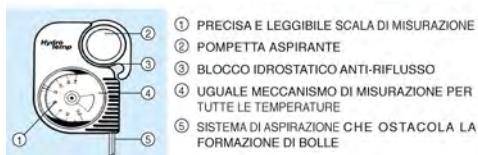

## Densimeter acid battery



- Check and measure the density in batteries.
- It determines the conditions of each element on both traditional batteries that single cover.
- Scale in degrees Baume and specific weight that indicates good, average, poor condition of the item.

Code	Desc.
4480000100	688

8

## Acid battery densimeter professional



- Verify and determine the exact state of charge and the density of battery acid.
- The mechanisms suction hinder the formation of bubbles or backflow.
- The measurement mechanism rotates 360 °, making the measurement independent of the position of the device.
- Tolerance  $\pm 1\%$ .

Code	Desc.
4480000900	801

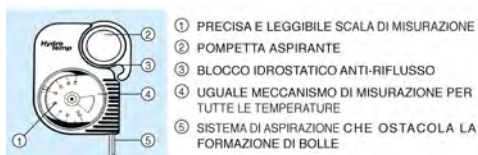



## Brake fluid tester



SEGNALA LA PRESENZA DI UMIDITÀ NEL LIQUIDO PER FRENI

CONTROLLA IL FLUIDO FRENI E FORNISCE UN'INDICAZIONE IMMEDIATA E INCONFUTABILE DELLA NECESSITA' O MENO DELLA SUA SOSTITUZIONE



- The main characteristic of the brake fluid is to be hygroscopic, a term which indicates a tendency to absorb moisture.
- Absorbing moisture through micropores present on pipes or through the seals, changes its main features, compromising the safety of the braking and then the driver.
- Due to the presence of water the boiling point of the brake fluid is lowered by increasing the possibility of formation of vapor bubbles, which prevents operation of the braking system.
- The increase of moisture also contributes to the formation of corrosion phenomena in the brake system.

### METHOD OF USE:

1. Press the button located at the end of the probe.
2. insert the probe in the reservoir of the brake fluid.
3. The color of the LED 3 shows the state of health of the liquid: green: the liquid is in excellent condition yellow: the liquid has absorbed a small amount of water. To check again in six months. red: the liquid contains a high amount of water. Drain the system and should be replaced. When done, double check with the tester.

### TECHNICAL DATA:

- Green led: <1.5% moisture.
- Yellow led: from 1.5 to 3% moisture.
- red led: > 3% moisture.
- Weight: 30 gr.
- Power: Supplied with battery 1.5V.

Code	Desc.
4770003100	311

8

## Infrared thermometer



ESEMPI DI APPLICAZIONE

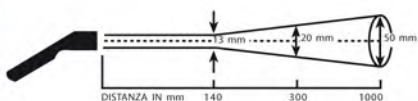

- Portable infrared thermometer.
- Fast and accurate diagnosis.
- Supplied with 9V battery.
- Essential for the temperature measurement of all types of mechanical parts, even difficult to reach.
- Measure the surface temperature of an object without touching it, based on infrared radiation.
- The ideal solution for measuring the temperature of inaccessible objects or moving.

### TECHNICAL FEATURES:

- Measuring range: -32 ° to 420 ° C.
- Optical resolution: 20: 1.
- Accuracy: ± 1% or ± 1 ° C from 0 ° C up to 420 ° C. ± 1% or ± 0.07 ° C from 0 ° C up to -32 ° C.
- Operating Temperature: 0 to 50 ° C.
- Response time: 0.3 sec.
- Weight: 150 gr.
- Dimensions: 190x38x45 mm.
- Display: ° C or ° F selectable backlit.

Code	Desc.
4770003105	312

## Digital thermometer



Code	Desc.
4770002280	228

- Essential tool whenever you need to detect temperatures.
- It is capable of detecting simultaneously two temperatures and to find the difference immediately thanks to the two probes in each room.
- It can keep memory temperatures by the "hold".
- It can detect the temperature in degrees centigrade (°C) or fahrenheit (°F).
- Thanks to the great work capacity (-50 + 1300 °C) is the ideal tool for the mechanic, the Radiatorista an electrical repair etc.
- Supplied with rubber coating for optimum protection against bumps and accidental falls.

### TECHNICAL DATA

- Measuring range: -50 to + 1,300 °C
- Margin of error: 0.3% ± 1 °C
- Overload Protection: 60V dc, 24V ac
- Probe: N - Cr - Ni - type "K"
- Battery: 9V type 5120000100
- Dimensions: 147 x 70 x 39 mm
- Weight: 0,370 kg.

### FUNCTION KEYS

- ON - Power
- OFF - off
- MAX - maximum temperature
- HOLD - key storage temperature
- F / C - key selection °C or °F
- T1 - select port / Probe No. 1
- T2 - select port / Probe No. 2
- T1 / T2 - key for the calculation of the temperature difference detected by the two probes.

## Try precision digital circuits



Code	Desc.
4770006550	742

- Practical circuits test instrument for voltages between 6 and 24 volts, with digital display of the detected voltage. Allows control of electrical circuits and the correct operation of electronic sensors on all vehicles.
- Can be used by all the garages and electrician, accurately detect voltages ranging from 5 to 28 Volts allowing you to control the output voltages from the electronic engine sensors.
- Current consumption of limited means, less than 10 mA, no effect on the tested circuit. instant indication of the voltage variations detected, illuminated display, the maximum length of ground wire 3.5 meters.
- The instrument is equipped with two probes needle to pierce the insulation of the wires and pick up the signal without damaging them. Length 18 cm each, a straight and a hook to fasten securely while you're working. The attack is the classic "banana" type for use with other tools and are also available separately from our test circuits.
- Instrument Dimensions: 130 X 35 mm. Weight: 160 g including the ground wire.

Spare Parts		
Article	Code	Desc.
Needle probe straight	4770006760	746
Needle probe hook	4770006765	746U

## Professional digital multimeter 500 V



- Digital multimeter with compact dimensions but very complete from the envelop, capable of current measurements and AC and DC voltages, Continuity test, resistance, square wave emission. Maximum applicable voltage: CAT II 600 V.
- Can be used anywhere you need accurate measurements: electrician, mechanics, electricians, electronic repair, maintenance, installation and maintenance in general.
- It has a clear backlit LCD display, of a body made of soft shock-absorbing material, backlight for a reading of the values even with low brightness, low battery indicator, memory of the readings.
- Supplied with: cables for measuring electrical classification 1000 V - 10 A, internal 9 V battery, internal fuse 200 mA, multilingual manual, shockproof casing.

Code	Desc.
4430057380	1050/1

Technical Features	
AC voltage	200V - 500V
Continuity	60Ω - +/-30Ω
square wave output value	50Hz - 10V - 470KΩ
Weight	170 g
Resistance	200Ω - 2MΩ
Dimensions	69 x 138 x 31 mm
Transistor hFE Test	NPN e PNP
Diode Test	1mV
DC Voltage	200mV - 500V
DC current	200μA - 10A



## Professional digital multimeter 1000V



- Professional digital multimeter compact, precise, the complete outfit.
- Ideal for all types of electrical and electronic measurement. Range of automatic measurement.
- Insulation Resistance class 2. IP67 dust and water.
- **Applications:** electricians, builders, installers, maintenance, automotive sector.
- **Features:** large high-contrast LCD display 4 digits. Button for the backlight.
- Auto-off after 15 minutes of inactivity. Possibility 't to store the measured values. gauge internal battery.
- Buzzer control continuity.
- Overload protection on all ranges, auto polarity.
- Operating temperature: or - 50 ° C.
- Power supply: 1 9V our article 5120000100
- Behind the protective shell: brings sleeves and eyelet for hanging the tester.
- Supplied with protective shell, ferrules, 9 volt battery (ns. Article 512 00 01040) custody and instruction booklet.

8

Code	Desc.
4430053900	1080

Tecnical Features	
Weight	375 g
Dimensions	182 X 82 X 66 mm
Test di continuità	Yes
Prova diodi	Yes
Frequenza max	10 MHz
AC max current	10 A
Resistenza max	40 Mohm
Max measurable capacity	200 µF
Duty cycle	99,9%
DC max current	10A
Tensione max AC	1000 V
Tensione max DC	1000V

Spare Parts		
Article	Code	Description
TIPS REPLACEMENT	4430053910	1081

# 1000 A digital clamp ammeter

 PUNTALINI  
DI RICAMBIO

8

- Professional digital caliper. precise, the complete outfit.
- Ideal for every type of electrical measurement.
- Buzzer control continuity and diode test.
- **Applications:** electricians, builders, installers, maintainers.
- **Features:** large LCD display with 4-digit analogue bar. Button for the backlight. ability to store the measured values.
- Overload protection on all ranges. operating temperature: -30 ° to 60 ° C. Automatic polarity. Out-of-scale.
- Auto-off after 20 minutes of inactivity.
- Power supply: 1 battery 9V our article 512 00 01040, the standard package. Battery level indicator.
- Equipped with a series of probe k for detections of temperatures from -40 ° C to + 1000 ° C.
- Provided with sleeves, probe, battery and instruction manual.

Code	Desc.
4430053920	1082

Tecnical Features	
Weight	303 gr with hull
Dimensions	229 x 80 x 49 mm
Opening	30 mm
Misurazione temporanea	-40°C to +1000°C
Temperatura	-40°C~1000c°
Misurazione capacità	4 nF to 40 mF
Frequenza max misurabile	4000 kHz
Misurazione resistenza	0,01 - 40MOhm
Tensione max AC	600 V
Tensione max DC	600 V
DC max current	1000 A
AC max current	1000 A

Spare Parts		
Article	Code	Description
TIPS REPLACEMENT	4430053910	1081



## Automotive Digital Multimeter



- Tester progettato secondo una tecnologia avanzata dotato di numerose funzioni elettriche e di misurazione.
- Apparecchio specifico per il settore auto-moto-cargo.
- Con libretto istruzioni e illustrazioni per le varie funzioni e misurazioni eseguibili.

Code	Desc.
4430049880	972-AM688

Technical Features	
Temperatura	750°
Resistance	Max 32 MW
Frequenza	320 Hz / 32 KHZ
DC Voltage	<1000 V
AC power	Up to 110A
DC current	Up to 10A
AC voltage	< 750 V

### MISURAZIONI

PROVA DIODI  
Contagiri motore (RPM, RPMx10)  
Dwell  
Impulso d'iniezione  
duty-cycle

## Universal kit for diagnosis (92 pieces)



- Full assortment of special terminals with wiring, specifically designed for quick and easy control of all sensors of the vehicles.
- Suitable for workshops and authorized generic, elettrauto, bodywork, camper, motorcycle workshop, fitters.
- The complete range can carry out checks and repairs of all the electrical and electronic vehicle without having to change the original wiring.
- Particularly suitable for control of electronic throttle bodies, airbags, air conditioning, engine operation sensors, satellite systems, alarms, hi - fi, parking sensors, electronic control units in general.
- Supplied in practical case with thermoformed to keep everything in perfect order and roll-top cover door tool.
- The kit is intended for use with our automotive digital multimeter (art. 443 00 49880) and with all diagnostic devices.
- The kit includes: 2 potentiometers, 2 LED indicators polarity, 2 connectors airbags, 2 connectors crocodile, 2 pointers generic probes 4 pin, 2 connectors female / male-male, 4 cables 1 m male-female, 75 wires wired male - female assorted.

Code	Desc.
4770004780	337

## Tester battery and alternator



- Test batterie 12V.
- Test alternatore.
- Uso facile ed intuitivo. Durata della prova: 15 secondi.
- Effettua il test della batteria secondo norme: EN - DIN - IEC - SAE - JIS.
- Adatto per batterie standard e con tecnologia gel.
- Compensazione della temperatura.
- Pinze ergonomiche isolate a doppio contatto (connessione tipo kelvin).
- Prova effettuata a bassa corrente, senza possibilita' di scintille o surriscaldamento per non danneggiare la centralina elettronica.
- Il test non scarica la batteria.
- Display 2x16 caratteri a elevata visibilita', con retroilluminazione a led.
- Possibilita' di lettura in 6 lingue.
- Contenitore in tecnopolimero, con guscio di protezione soft-touch.
- Imballaggio in custodia protettiva con semplici e dettagliate istruzioni per l'uso in piu' lingue.

Code	Desc.
4430047870	863

## Tester per batterie e alternatori con stampante



- IDEAL FOR WORKSHOPS AND ELETTRAUTI
- Tool to perform checks on batteries and alternators
- An important advantage is the printing to show to the customer
- Protected against reverse polarity of the terminals
- Equipped with thermal printer, use 57mm standard thermal paper
- Graphic LCD with lighting
- Data printing: (SOH) battery health and (SOC) charge level
- Clock-date and time function
- Powered by 6 AA batteries ns. code 5120001020 (not included)
- Equipment: 2 rolls of thermal paper, instruction manual, shockproof case



Code	Desc.
4430047872	863/ST Tester con stampante

Spare Parts	
Code	Description
5120001020	360-LR6 alkaline stylus
4430047873	863/C Cable with pliers
4430047874	863/R Thermal paper roll H 57 mm

Technical Features	
Operating temperature	0° C / 50° C ( 32° F / 122° F)
Dimensioni L x L x P mm	275 x 135 x 80
Weight	1,5Kg-Tester 3,7Kg (complete case)
Tipo di batterie	EFB-AGM FLAT PLATE-LIQUIDO STANDARD (PIOMBO)-AGM SPIRALE-VRLA-GEL
Misurazioni standard	SAE (CCA) (40-3000 CCA)   EN (40-2100 CCA)   IEC (30-1985 CCA)   DIN (25-1685 CCA)   JIS (da codice batteria)
Tipo alternatori	12 / 24 V
Battery voltage	12 V (start & stop) 6V-12V

## Battery tester with lid



- This tester provides two types of evidence:
  - 1) with resistance included: state of battery charge. The test is run from pole to pole: the instrument shows the state of charge of the battery.
  - 2) with resistance off: regulator setting.
- The test is performed on the battery poles: the instrument indicates the rated voltage of the regulator and the battery voltage load, the voltage drop when the tool.
- technical features:
  - Precision instrument with moving coil.
  - Large-scale reading at 6 and 12 volts.
  - Ergonomic handle plastic anti oil, anti-acid.
  - Detailed instructions in each box.

Code	Desc.
4430046134	654

### screwdriver phase finder



- For AC 110V - 380V.
- UNI 7076 - ISO 2380 - DIN 5264.

Code	Desc.
4430022600	299 - 4x160

### Screwdriver phase finder for cars



- For DC 6V to 24V.
- UNI 7076 - ISO 2380 - DIN 5264.
- Detects the presence of voltage; the circuit is closed by anchoring the clamp to a metal part.
- Lama silicon chromium nickel vanadium running.
- Cable length 750 mm.

Code	Desc.
4430022500	298 - 3x160

8

### Try gasoline fuel pressure



- Precision device for rapid diagnosis and recording of pressure and leak testing in gasoline injection engines.
- Compatible with Bosch LK-jetronic, motronic, weber, efi, etc ...
- The apparatus comprises: a precision pressure gauge d. 100 mm from 0 to 12 bar, three taps watertight, three pipes radiused 10x1-12x1.5- 14x1.5 and a series of threaded fittings and smooth for connecting the tester to all types of mechanical and electronic injection systems and a set of hoses with quick couplings for plants with this new system of insertion into the circuit of the fuel.
- Tests can be performed on the Fiat-Alfa-Romeo Lancia-BMW-VW-Ford-Citroen-Peugeot-Volvo-Porsche-Ferrari-Maserati-Mercedes-Seat-Audi-Honda-Toyota.
- With instruction booklet attached.
- For all workshops and elettrauto.

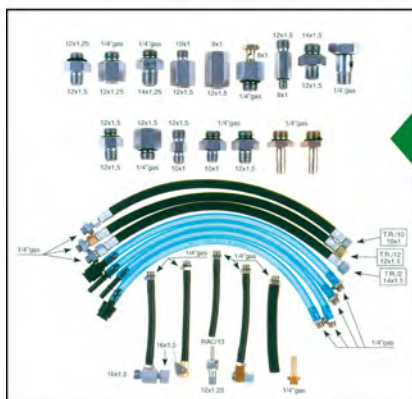

RACCORDI CONTENUTI NEL KIT

Code	Description
4430047865	862



## Try compression petrol



- To measure promptly the values of compression is not uniform among the individual cylinders.
- Scale: 0-21 bar, 0-300 psi.
- To plug hole  $\varnothing$  14 and 18 mm.
- Threaded connection with crosshatch for secure connection to the plug hole of the engine block.
- Outlet valve easily accessible.

Code	Desc.
4430045030	531

## Kit control common rail injectors



- Practical kit for the rapid diagnosis of the proper functioning of the injectors for common rail injection systems.
- Product suitable for workshops and authorized generic cars and commercial vehicles, elettrauto.
- The system allows, through containers, graduated, to accurately measure the return flow of diesel fuel from the injectors.
- The kit for testing engines up to 6 cylinders.
- Kit designed exclusively for iniettor Bosch.

Code	Desc.
4770004790	338

## Adapter kit for common-rail injectors



- The kit contains 24 adapters for injectors of last generation marked bosch, siemens, Delphi, dense.
- For use in combination with our code 4770004790-kit seal control common rail.
- Possibility of measurement for engines up to 6 cylinders.
- Product suitable for workshops generic cars and commercial vehicles.
- Details of the applications are in the instruction book.

Code	Desc.
4770004795	338 A



### Magnetic small parts holder



- ABS tray designed to contain small parts during the disassembly and reassembly phases of vehicles, machinery, and equipment of any type.
- The external magnet applied can be placed close to the working place.
- The inner magnet contains the parts in the tray.
- The tilted position allows to contain and give an easy access even if positioned on perpendicular surfaces.
- Size: diameter 145 mm, height 110 mm
- Weight: 360 g



Code	Description
4430058510	1798-Magnetic small parts holder

8

### Carafes graduated in polietilene



- With lip versatore
- With graduated staircase
- For the I decant of oils, combustible, various liquids
- Suitable also for foods
- Ideal for shops, body shop, laboratories
- Produced in material nontoxic

Code	Desc.	Capacity Lt	Photo
4430057420	1768/0,5	0,5	1
4430057430	1768/1	1	2
4430057440	1768/3	3	3
4430057450	1768/5	5	4
4430057460	1768/k	0,5+1+3+5	5

## Mixer for distilled water



- With automatic level.
- Plastic resistant to oils, acids and solvents.
- Capacity 2 liters.

Code	Desc.	Capacity Lt
4430044870	516	2

## Spout for liquids



- Polyethylene.
- With scale division lt / lt.

Code	Desc.	Capacity Lt
4430045800	610-1	1
4430045802	610-2	2
4430045804	610-5	5

## Funnel graduated



- Funnel graduated plastic material.
- Suitable for motorcycle workshop, workshops generic bodies, dealerships, service stations.
- Resistant to gasoline, solvents, oil, antifreeze.
- Composed of a detachable extension transparent rubber, length 30 cm, suitable for pouring liquids in uncomfortable positions and places not reached by the traditional funnels.
- Complete with handle for pre-mixing and cover that allows to use the article also as a handy container.
- Provided with valve open and close.
- Capacity: 1 liter.

Code	Desc.	Diameter cm
4430040847	460A	11,5 cm

### Plastic funnel with extension



- Funnel polyethylene.
- Resistant to gasoline, oil, antifreeze, solvents.
- With removable flexible neck.
- Supplied with filter.
- Diameter 21 cm.
- Total length: 55 cm.

Code	Desc.
4430040848	459/P

### Plastic funnel



- Resistant to gasoline, solvents, antifreeze, oil.
- Great ability to transfer.
- With filter.

Code	Desc.	Funnel Ø
4430045946	620-14	14 cm
4430045948	620-21	21 cm
4430045950	620-30	30 cm

### Funnel for fire



- Entrance framework.
- Resistant to gasoline, solvents, antifreeze, oils.

Code	Desc.
4430045952	620-F

8

## Tanks for flammable liquids



- Plastic tanks capable of transporting liquids.
- Suitable for car and motorcycle workshops, body shops, dealerships, all customers who make emergency road, marine industry, construction industry and handicrafts.
- Made of plastic material treated to contain flammable liquids (fuel, solvents). They can also be used for the transportation of gasoline or other substances on jobs for the purpose of powering a generator or internal combustion engines.
- The plastic tanks are available in different sizes (5, 10, 20 liters) to fit the available space.
- Equipped with nozzle spout anti regurgitation flexible for better management of the operation of racking and safety cap anti unscrewing.
- Complying with the directive "A" 96/49 / EC for the transport of flammable liquids.

Code	Description	Capacity Lt	H	L	P
4430055620	1360/5	5	250	230	150
4430055625	1360/10	10	298	298	195
4430055635	1360/20	20	400	350	195
4430055636	1360B - flexible spout for cans 5/10 lt	-	-	-	-

## Metal tank military



- For transport fuels.

Code	Description	Capacity Lt
4430046000	624-10	10
4430046001	624-20	20
4430046002	624B BECCUCCIO FLESSIBILE	-

### Binder used oil



- Ideal for oil change and cleaning individual parts.
- With rise in support for the dirty parts.
- With 3 handles for safe transport.
- Impact-resistant plastic.
- Secure payment via drip edge and spout outlet.

Code	Desc.	Litri	H mm	Dimension cm
4430051790	1060	8	130	32x38
4430051800	1061	16	150	40x45

### Waste oil collector 24 l



- Large collection tank waste oil 24 l.
- Produced polyethylene.
- Article VI indicated for workshops, earthmoving, truck bodies and service stations.
- Length .: 82 cm; width.: 53 cm; Height: 19cm.

Code	Description
4430051805	1061/24 COLLECT OIL 24 LT

8

### Tank for hub



- Practical pan-shaped plastic material.
- Ideal for oil recovery during the disassembly for maintenance or repair hub of commercial vehicles with dual rear wheels with hub.
- The tray fits perfectly on hard 13".
- With a capacity 'of recovery of 2.6 liters.

Code	Desc.	Capacity Lt
4430050890	1027	2.6





## Electric and pneumatic tools

Piping and hose reels . . . . .	pag. 1060	Tools wire electric. . . . .	pag. 1154
Compressed air fittings . . . . .	pag. 1064	Accessories for electric tools . . . . .	pag. 1208
Compressors . . . . .	pag. 1088	Workshop lamps and electric winders . . . . .	pag. 1213
Pneumatic tools . . . . .	pag. 1092	Starters and battery chargers. . . . .	pag. 1231
Battery-powered electric tools . . . . .	pag. 1125		

## Polyurethane spiral air passage



- Spiral polyurethane already filleted.
- Mount swivels threaded male.
- Operating temperature -40 ° C + 80 ° C.
- Operating pressure of 12 bar.

Code	Desc.	Ø int. x Ø est	Tipo di racc. girevole	Length m	Color
3450008230	253	5,5x8	1/4" GAS M.	12	GREEN
3450008240	254	8x12	1/4" GAS M.	8	LIGHT BLUE
3450008250	255	10x16	3/8" GAS M.	8	AZZURRO
3450008260	256	13x19	1/2" GAS M.	8	AZZURRO

## Polyurethane tube air passage connected



- Roll of tube already filleted.
- Mounted fittings with threaded outlet.
- Operating temperature -40 ° C + 80 ° C.
- Operating pressure of 12 bar.

Code	Desc. Ø int. x Ø ext.	Rotolo m	Gas Connector
373PU00100	8x12	10	1/4" F.
373PU00110	8x12	20	1/4" F.
373PU00200	10x16	10	3/8" F.
373PU00210	10x16	20	3/8" F.
373PU00300	13x19	10	1/2" M.
373PU00310	13x19	20	1/2" M.

## Rubber hose for compressed air



- Supplied in coils.
- Black color outer jacket.
- Soul black.
- Listing the polyester fabric.

Code	Desc. Ø int. x Ø ext.	Press. Eserc. Bar	Temp. Eserc. °C
3730G00100	6x14	20	-25 +60
3730G00200	8x17	20	-25 +60
3730G00350	10x19	20	-25 +60
3730G00400	13x23	20	-25 +60
3730G00450	16x26	20	-25 +60

## PVC pipe for compressed air



- Supplied in coils.
- Color outer jacket sand.
- Soul black.
- Listing fiber polistere intertwined.
- Complies with ISO 5744 and ISO 1401.
- NB: tube light and highly resistant to abrasion and UV rays.

Code	Desc. Ø int. x Ø ext.	Operating press. BAR
373AP00100	6x11	20
373AP00200	8x13	20
373AP00300	10x16	20
373AP00400	13x19	20
373AP00500	16x23	20

## Spiral Rilsan PA11



- Spirals Polyamide 11 for pneumatic use.
- Linear length 10 m.
- Color: orange.

Code	Desc. <i>∅ int. x ∅ ext.</i>	Explosion pressure <i>to + 20°C bar</i>
345000030	4x6	96
345000050	6x8	50
3450000100	8x10	53
3450000200	10x12	44

## Rilsan tube for pneumatic braking systems



- Polyamide 10 "Rilsan" PA11 depending on the supplies.
- To standard DIN 74324 and DIN 73378.
- Supplied in coils.

Code	Desc. <i>∅ int. x ∅ ext.</i>	Color	Explosion pressure <i>to + 20°C bar</i>
3740000150	2x4	NEUTRAL	132
3740000155	2x4	BLACK	132
3740000200	4x6	NEUTRAL	80
3740000210	4x6	GREEN	80
3740000220	4x6	BLUE	80
3740000230	4x6	RED	80
3740000240	4x6	YELLOW	80
3740000250	4x6	BLACK	80
3740000280	6x8	NEUTRAL	57
3740000300	6x8	BLACK	57
3740000305	6x9	BLACK	57
3740000350	7x10	BLACK	57
3740000450	8x10	BLACK	44
3740000460	8x10	BLUE	44
3740000500	8x12	BLACK	57
3740000510	9x12	YELLOW	57
3740000515	9x12	BLACK	57
3740000520	9x12	RED	57
3740000550	10x12	NEUTRAL	44
3740000560	10x12	BLACK	44
3740000600	12x14	BLACK	44
3740000650	12x15	BLACK	44
3740000700	12x16	BLACK	57
3740000800	14x18	BLACK	50
3740000950	16x20	BLACK	50



## Annealed copper pipe



- Suitable for civil and industrial installations.
- The annealing ensures a good malleability and a shaping manual.
- Supplied in coils in meters.
- Tube used for braking systems industrial vehicles.

Code	Desc. <i>external diameter</i>	Thickness <i>mm</i>	Meters per kg.
4290000100	5	1	1Kg. = m. 8,9
4290000150	6	1	1Kg. = m. 7,1
4290000200	8	1	1Kg. = m. 5,1
4290000300	10	1	1Kg. = m. 3,9
4290000400	12	1	1Kg. = m. 3,2
4290000500	14	1	1Kg. = m. 2,75
4290000600	15	1,5	1Kg. = m. 1,76
4290000700	16	1	1Kg. = m. 2,4
4290001000	20	1,5	1Kg. = m. 1,3
4290001100	22	1,5	1Kg. = m 1,01

## Hose reel for compressed air ø 8 mm 10-meters

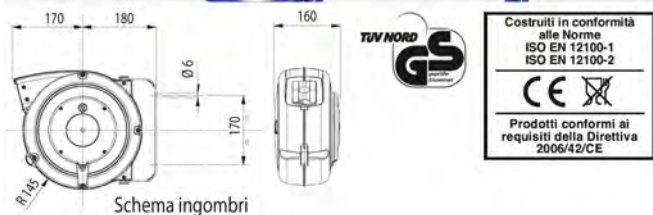

- Hose reel for compressed air ø 8 mm 10-meters
- Automatic hose reel with return spring, adjustable bracket, polyurethane hose wired polished length 9 meters + 1 meter outside.
- Housing impact resistant plastic, oil resistant, resistant to weathering and chemicals.
- Pipe extremely flexible and light.
- Steel mounting bracket.
- Device for automatic switching of the tube to the desired length which can be switched off to keep the tube in traction.
- Ideal in all companies for the transport of compressed air with a maximum pressure up to 15 bar, for the actuation of pneumatic machines, inflating, blow molding and cleaning, etc.
- Possibility of using the same for the passage also of cold water.
- Working temperature from -5 ° C to + 40 ° C, length of tube in input of internal diameter 8 mm and length 1.5 meters, fitting threaded outlet 1/4 "male with rubber protection.

Code	Desc.
3450100800	1708

## Compressed air hose reel $\varnothing$ 8:10



- New housing impact resistant plastic.
- New enhanced internal spring.
- Inner joint new concept for an optimum air passage.
- With automatic stop device of the tube to the desired length
- With adjustable bracket for wall mounting.
- Inner tube with polyurethane finish.
- With length of 2 m incoming.
- Operating temperature from  $-5$  to  $40$  ° C
- Max pressure 15 bar.
- Suitable for air and cold water.
- To power all air tools.

Code	Desc.	Length m	Raccordo entrata / uscita	$\varnothing$ int. tubo	$\varnothing$ est. tubo
3450100580	1706/8	15+1	1/4 M	8	10,5
3450100600	1706/10	15+1	3/8 M	10	14,5

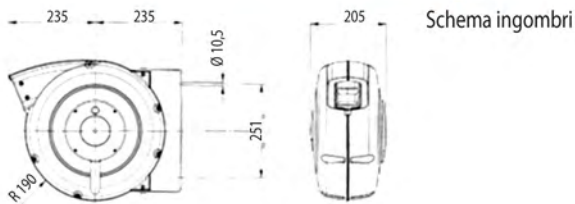

## Compressed air hose reel $\varnothing$ 13mm

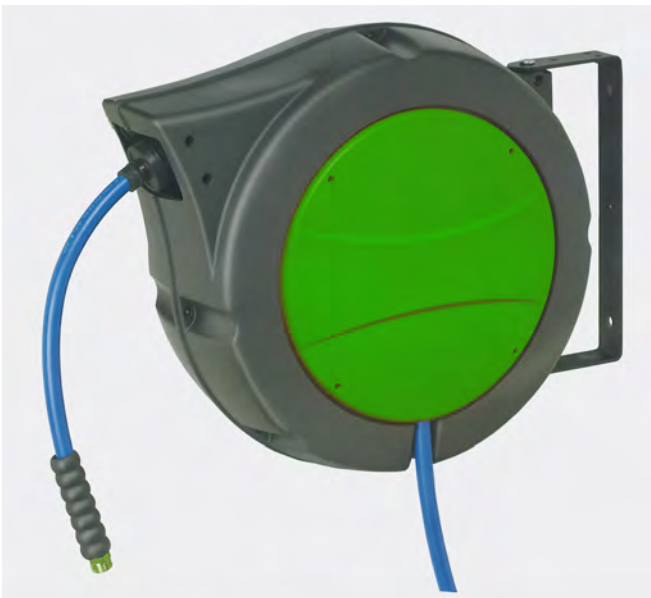

- Automatic hose reel with spring winding.
- Stop device of the tube.
- Swivel bracket.
- External structure polymer.
- Maximum operating pressure: 15 bar.
- Operating temperature:  $-5$  ° C +  $40$  ° C.
- Suitable for the passage of air and cold water.
- Pipe length: 15m + 1m wrapped outside.
- Supplied with 1.5 m hose inlet with 1 / 2M and male fitting 1/2 output.
- Weight: 13kg.

Code	Desc.
3450100450	1704/13

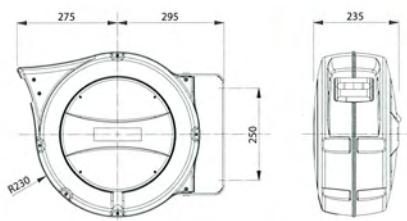



## Filter - regulator - lubricator



- Three in one tool which combines in a single body for the air filter, regulator and lubricator outlet pressure in line for pneumatic tools.
- Necessary where there is any type of compressed air system for the protection and longer life of machines and pneumatic tools.
- Cup condensate trap to jettison, pressure regulator piston with locking knob, lubricating oil mist with special cup and tap for the exclusion, when powered guns.
- Complete with mounting brackets, pressure gauge for the indication of the air outlet pressure, shock-proof plastic cups in unbreakable and reductions for inlet and outlet 1/2" - 3/8".

Code	Desc.
3450010100	280-3/8

Technical Features	
Lubricant Setting range	1 drop / 300-600 NL / min.
Inlet diameter with reductions	1/2" - 3/8"
Elemento filtrante	10 micron
Pressure setting range	0-10 bar
Pressione massima d'ingresso	14 bar
Temperatura massima d'esercizio	60° C

Spare Parts		
Article	Code	Description
Gauge parts	345RC04990	401
Reducing input-output 1/2" - 3/8"	1760023994	2614-1/2-3/8

## Pressure reducer at piston



- Pressure reducer piston control knob can be locked.
- Threaded holes in the inlet and outlet diameter 1/2".
- Maximum inlet pressure 14 bar.
- Setting range from 0 to 12 bar. Maximum air flow rate 6,000 l / min.
- Pressure gauge.

Code	Desc.
3450010330	286

Spare Parts		
Article	Code	Description
Gauge parts	345RC04990	401
Reducing input-output 1/2" - 3/8"	1760023994	2614-1/2-3/8

## Anti-condensation filter



- Filter condensation container for all compressed air systems.
- Collection cup quick exhaust, air inlet and outlet diameter threaded female 1/2 ".
- Minimum 10 micron filtration. Maximum inlet pressure 14 bar. Maximum flow rate 6,000 l / min. at 6 bar.

Code	Desc.
3450010340	287

Spare Parts			
Article	Code	Description	
Reducing input-output 1/2 "-3/8"	1760023994	2614-1/2-3/8	

## Mist lubrication oil



- Lubricator online oil mist for compressed air systems.
- Cup reinforced. Mixer tap for regulating the flow of oil and complete closure. Maximum inlet pressure 14 bar. Air flow maximum 6,000 nl / min. Oil flow in adjustable output of 1 drop from 300 to 600 l / min.
- Complete with brackets for wall fixing.

Code	Desc.
3450010350	288

Spare Parts			
Article	Code	Description	
Reducing input-output 1/2 "-3/8"	1760023994	2614-1/2-3/8	

## Air Oil



- Special oil of paraffinic nature for compressed air systems, to preserve them from the corrosive action of the condensate.
- Excellent resistance to oxidation.
- High power rust.
- High demulsibility, ease of spraying.
- Viscosity at 40 ° C: 13.5 to 15.5 Cst.
- Scrolling: -22 ° C.
- Essential lines of compressed air to preserve the solenoid valves and pneumatic tools.

Code	Desc.	Content It
4110014865	2785	1

## Raccordi rapidi di sicurezza ISO6150B



**COMPATIBILITA' FRA VALVOLE ED INNESTI**



- RACCORDI ARIA DI SICUREZZA PER ALIMENTAZIONE DI MACCHINE PNEUMATICHE DI OGNI TIPO, COSTRUZIONE IN ACCIAIO CON RIVESTIMENTO IN MATERIALE COMPOSITO RESISTENTE AGLI URTI ED ALL'ABRASIONE. REALIZZATI SECONDO LE NORMATIVE INTERNAZIONALI ISO 6150 B, US MIL 4109 C ED NF E 49053. LO SGANCIO DEGLI INNESTI AVVIENE IN DUE TEMPI, PERMETTENDO ALL'ARIA COMPRESA DI USCIRE DALLA TUBAZIONE. VENGONO ELIMINATI I PERICOLOSI COLPI DI FRUSTA AL MOMENTO DEL DISINNESTO, CON CONSEGUENTI URTI A COSE E PERSONE. RISPONDENTI ALLE NORMATIVE DI SICUREZZA ISO 4414 E DIN EN 983 CONTRO GLI INFORTUNI SUL LAVORO. ELEVATA PORTATA D'ARIA, LEGGEREZZA E RESISTENZA MASSIMA. AGGANCI SICURI E SEMPLICI, TENUTA ALLE ELEVATE PRESSIONI
- GARANTITA DA APPOSITE GUARNIZIONI IN NITRILE RESISTENTI AD OLI, CONDENSA ED ACQUA.

**NORMATIVE DI RIFERIMENTO COSTRUZIONE E COMPATIBILITA' PER IL MONTAGGIO CON RACCORDI RISPONDENTI ALLE NORMATIVE:**

- ISO 6150 Serie B
- US MIL 4109 C
- NF E 49053.

**COSTRUZIONE RISPONDENTE ALLE NORMATIVE INTERNAZIONALI SULLA SICUREZZA DEL LAVORO:**

- ISO 4414
- DIN EN 983

Ø passaggio aria	Ø entrata femmina mm	Ø esterno maschio mm
6 mm.	12	12
8 mm.	15	15
11 mm.	17	17

### Valve threaded female



- Female threaded gas.

Code	Desc.	Ø Tubo mm	Gas thread A	Thread A mm	Diametro interno B mm	Length mm	Key measure mm
3450010360	289-1/4	6	1/4	11.5	12	64	17
3450010370	289-3/8	6	3/8	15.0	12	71	21
3450010380	290-3/8	8	3/8	15.0	15	74	21
3450010390	290-1/2	8	1/2	19.0	15	84	25
3450010400	291-1/2	11	1/2	19.0	17	86	30

### Valve male thread



- Threaded gas with PTFE coating
- It ensures maximum speed of assembly and a perfect seal.

Code	Desc.	Ø Tubo mm	Gas thread C	Thread C	Int. diameter Dmm	Width mm	Key measure mm
3450010410	292-1/4	6	1/4	13 mm	12	74.5	17
3450010420	292-3/8	6	3/8	16.5 mm	12	77	21
3450010430	293-3/8	8	3/8	16.5 mm	15	86	21
3450010440	293-1/2	8	1/2	21 mm	15	89	25
3450010450	294-1/2	11	1/2	21 mm	17	89	30

## Valve with barb



- With barb fittings.
- It allows an extremely rapid mounting on any type of pipe for compressed air.

Code	Desc.	Ø passaggio aria mm	For pipes Ø int. mm	Ø interno E mm	Length mm
3450010460	295-6	6	6-7	12	82
3450010470	295-8	6	8	12	82
3450010480	295-10	6	9-10	12	82
3450010490	296-8	8	8	15	92
3450010500	296-10	8	9-10	15	92
3450010510	296-13	8	13	15	95
3450010520	297-16	11	16	17	109
3450010530	297-19	11	19	17	156

## Quick coupling female thread

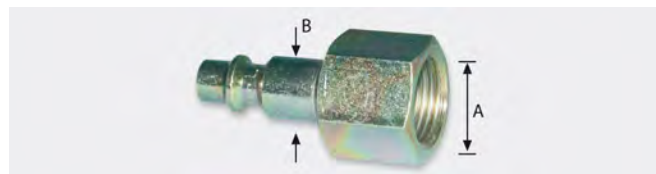

Code	Desc.	Ø Tubo mm	Gas thread A	Thread A mm	Ø esterno B mm	Length mm	Key measure mm
3450010540	298-1/4	6	1/4	11.5	12	41	17
3450010550	298-3/8	6	3/8	15.0	12	45	21
3450010560	299-1/4	8	1/4	11.5	15	45	17
3450010570	299-3/8	8	3/8	15.0	15	49	21
3450010580	299-1/2	8	1/2	19.0	15	53	25
3450010590	300-1/2	11	1/2	19.0	17	60	27

## Quick connect male thread

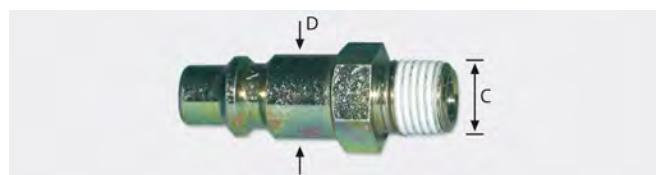

- Threaded gas with PTFE coating
- It ensures maximum speed of assembly and a perfect seal.

Code	Desc.	Ø Tubo mm	Gas thread A	Thread C	Ø esterno D mm	Length mm	Key measure mm
3450010600	301-1/4	6	1/4	13.0 mm	12	43	14
3450010610	301-3/8	6	3/8	16.5 mm	12	43	17
3450010620	302-1/4	8	1/4	13.0 mm	15	48	17
3450010630	302-3/8	8	3/8	16.5 mm	15	48	21
3450010640	302-1/2	8	1/2	21.0 mm	15	58	25
3450010650	303-1/2	11	1/2	21.0 mm	17	80	27

## Quick coupling with herringbone

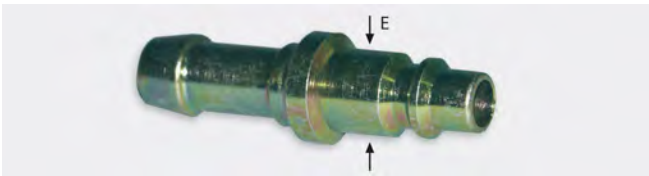

Code	Desc.	Ø passaggio aria mm	For pipes Ø <sub>int.</sub> mm	Ø esterno E mm	Length mm
3450010660	304-6	6	6-7	12	54
3450010670	304-8	6	8	12	56
3450010680	304-10	6	9-10	12	56
3450010690	305-8	8	8	15	62
3450010700	305-10	8	9-10	15	62
3450010710	305-13	8	13	15	67
3450010720	306-16	11	16	17	100
3450010730	306-19	11	19	17	116



## RACCORDI PER ARIA COMPRESSA

TABELLA FILETTATURA GAS CON COMPARAZIONE IN MILLIMETRI

Ø NOMINALE G (")	Ø d mm	FILETTI PER POLLICE	Ø D mm
G 1/8"	9,73	28	8,57
G 1/4"	13,16	19	11,45
G 3/8"	16,66	19	14,95
G 1/2"	20,96	14	18,63

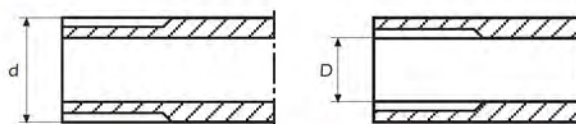

## IDENTIFICARE LA SERIE DI RACCORDI



SERIE ITALIA



SERIE GERMANIA



SERIE GIAPPONE

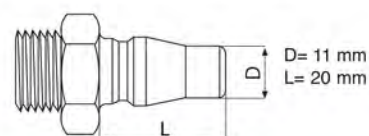
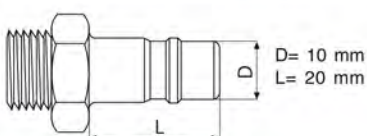
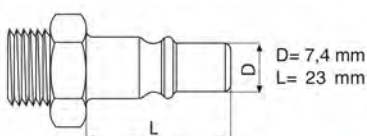

## VARIE POSSIBILITA' DI APPLICAZIONE

### ESEMPIO 1



TUBO IN RILSAN

TUBO IN POLIURETANO



POLIURETANO



RACCORDO GIREVOLE



### ESEMPIO 2



TUBO IN GOMMA

TUBO IN PVC



RACCORDO FILETTATO MASCHIO CON RESCA



FASCETTE CONSIGLIATE PER FISSAGGIO TUBO



NS. ART. 300 00



NS. ART. 312 00



## VARIE POSSIBILITA' DI APPLICAZIONE

L'innesto filettato maschio viene montato sull'utensile

La valvola o il raccordo a baionetta vengono montati sulla tubazione



### Male swivel fitting for spiral



- For spirals rilsan and polyurethane.

Code	Desc.	Gas thread
3450008270	257-6x4	1/4" M
3450008280	257-8x6	1/4" M
3450008290	257-10x8	1/4" M
3450008300	257-12x8	1/4" M
3450008305	257-12x8	3/8" M
3450008310	257-12x10	3/8" M
3450008330	257-16x10	3/8" M
3450008340	257-19x13	1/2" M

### Male adapter with herringbone

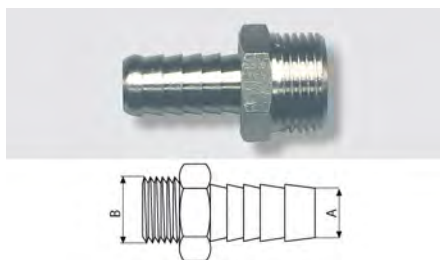

- For rubber and PVC hoses.

Code	Desc.	Diametro Resca A	Gas thread B
3450008850	270-6-1/4	6	1/4" M
3450008900	270-8-1/4	8	1/4" M
3450008910	270-8-3/8	8	3/8" M
3450008950	270-10-3/8	10	3/8" M
3450009000	270-12-3/8	12	3/8" M
3450009050	270-14-3/8	14	3/8" M
3450009100	270-16-3/8	16	3/8" M
3450009150	270-16-1/2	16	1/2" M

## Rotary connection with rubber hose



- For polyurethane tubing and PVC.

Code	Desc.	Gas thread
3450008350	258-12x8	1/4" M
3450008360	258-16x10	3/8" M
3450008370	258-19x13	1/2" M

## Joints for air fittings Male-Male

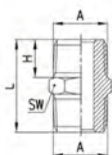

- Allow to join two of connected pipe sections.

Code	Desc.	gas thread male (A)
1760023950	2612-1/4	1/4" - 1/4"
1760023960	2612-1/8	3/8" - 3/8"
1760023961	2612-1/2	1/2" - 1/2"
1760023962	2612-3/4	3/4" - 3/4"

## Reduction for air fittings Male-Male

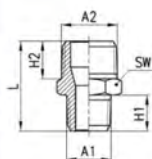

- Allow to join two lengths of hose assemblies.

Code	Desc.	gas thread male (A)
1760024100	2614-1/8-1/4	1/8" - 1/4"
1760024120	2614-1/4-3/8	1/4" - 3/8"
1760024130	2614-1/4-1/2	1/4" - 1/2"
1760024140	2614-3/8-1/2	3/8" - 1/2"
1760024150	2614-1/2-3/4	1/2" - 3/4"

## Reduction for air fittings Male-Female

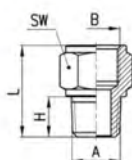

- Allow to join two lengths of hose assemblies.

Code	Desc.	gas thread male (A)	Gas thread female (B)
1760024200	2615-1/8-1/8	1/8"	1/8"
1760024210	2615-1/8-1/4	1/8"	1/4"
1760024240	2615-1/4-3/8	1/4"	3/8"
1760024250	2615-1/4-1/2	1/4"	1/2"
1760024260	2615-3/8-3/8	3/8"	3/8"
1760024270	2615-3/8-1/2	3/8"	1/2"
1760024280	2615-1/2-1/2	1/2"	1/2"



### Joints for fittings air Female – Female

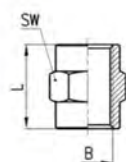

Code	Desc.	Gas thread female (B)
1760023970	2613-1/4-1/4	1/4" - 1/4"
1760023976	2613-3/8-3/8	3/8" - 3/8"
1760023980	2613-1/2-1/2	1/2" - 1/2"

### Reduction for air fittings Female – Female

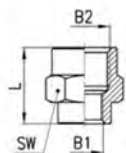

Code	Desc.	Gas female thread (B1-B2)
1760024300	2616-1/8-1/4	1/8" - 1/4"
1760024330	2616-1/4-3/8	1/4" - 3/8"
1760024340	2616-1/4-1/2	1/4" - 1/2"
1760024350	2616-3/8-1/2	3/8" - 1/2"

### Reduction for air fittings Female – Female

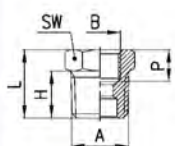

Code	Desc.	gas thread male (A)	Gas thread female (B)
1760023990	2614-1/4-1/8	1/4"	1/8"
1760023992	2614-3/8-1/4	3/8"	1/4"
1760023994	2614-1/2-3/8	1/2"	3/8"
1760023995	2614-3/4-3/8	3/4"	3/8"

### Fitting "L" for air connections Female – Female

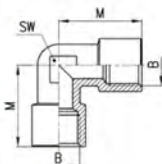

Code	Desc.	Gas thread female (B)
1760024000	2700-1/8	1/8"
1760024010	2700-1/4	1/4"
1760024020	2700-3/8	3/8"
1760024030	2700-1/2	1/2"

### Fitting "L" for air fittings Male – Female

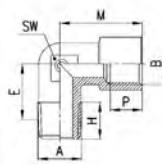

Code	Desc.	gas thread male (A)	Gas thread female (B)
1760024040	2710-1/4-1/4	1/4"	1/4"
1760024050	2710-3/8-3/8	3/8"	3/8"
1760024060	2710-1/2-1/2	1/2"	1/2"

### Union "T" fittings for air-female-male-female

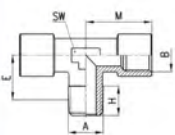

Code	Desc.	gas thread male (A)	Gas thread female (B)
1760024070	2720-1/4-1/4	1/4"	1/4"
1760024080	2720-3/8-3/8	3/8"	3/8"
1760024090	2720-1/2-1/2	1/2"	1/2"

## Union "Y" fittings for air Tapped- Female-Male



Code	Desc.	gas thread male (A)	Gas thread female (B)
3450009200	271-1/4	1/4"	1/4"
3450009250	271-3/8	3/8"	3/8"
3450009300	271-1/2	1/2"	1/2"

## Union "Y" fittings for air Tapped- Female



Code	Desc.	Gas thread female (B)
3450009350	272-1/4	1/4"
3450009400	272-3/8	3/8"
3450009450	272-1/2	1/2"

## Fitting "cross" for air fittings Female

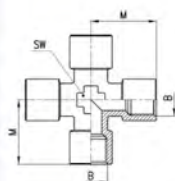

Code	Desc.	Gas thread female (B)
1760024095	2730-1/4	1/4"
1760024096	2730-3/8	3/8"

## Threaded plugs

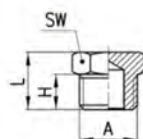

Code	Desc.	gas thread male (A)
1760023940	2611-1/4	1/4"
1760023946	2611-1/2	1/2"

SERIE ITALIA



## Raccordi per aria compressa

### Fitting with bayonet connection and spring spiral

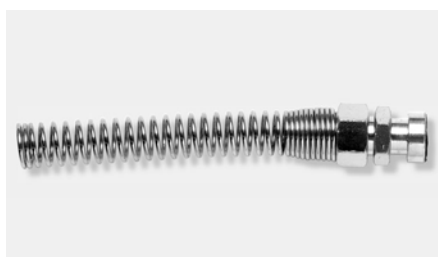

Code	Desc.	For spiral
3450001202	185-4x6	4x6
3450000450	174-6x8	6x8
3450000500	175-8x10	8x10
3450001207	188-10x12	10x12



## Fitting with bayonet connection for rubber tube



Code	Desc.	For pipe Ø
3450001050	182/1-8x17	8x17
3450001055	182/2-10x19	10x19

## Female fitting with bayonet connection



- For transformation of pipes already jointed.

Code	Desc.	Gas thread
3450009500	273-1/4	1/4" F
3450009550	273-3/8	3/8" F

## Seal for bayonet connection



- Replacement seal for fittings Italy bayonet.

Code	Desc.
3450008100	241

## Fitting for bayonet connection male thread



Code	Desc.	Gas thread
3450001090	183-1/4	1/4" M
3450001100	183-3/8	3/8" M

## Double fitting for bayonet connection



- For joining pipes with fittings Italy bayonet.

Code	Desc.
3450001200	184

## Coupling with bayonet connection



- For transformation tools by bayonet quick coupling.

Code	Desc.
3450000950	180

## Coupling with male thread



Code	Desc.	Gas thread
345000955	181-1/8	1/8" M
345000956	181-1/4	1/4" M
345000960	181-3/8	3/8" M

## Coupling with female thread

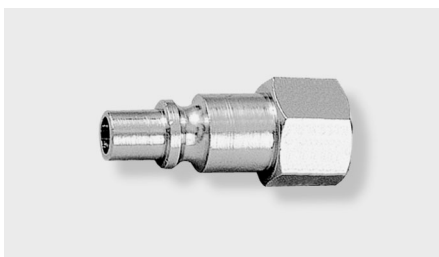

Code	Desc.	Gas thread
3450008400	259-1/4	1/4" F
3450008410	259-3/8	3/8" F

## Plug with spring

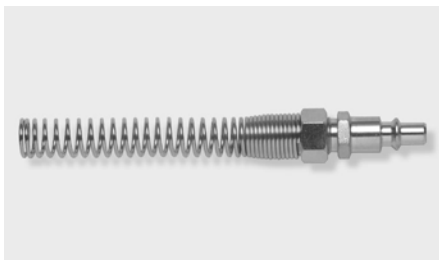

Code	Desc.	For spiral
3450002250	170-6x8	6x8
3450003300	171-8x10	8x10
3450001208	189-10x12	10x12

## Coupling with hose connection



Code	Desc.	For pipe Ø
3450000900	179-6x14	6x14
3450000940	179/1-8x17	8x17
3450000945	179/2-10x19	10x19

## Valve with male thread



Code	Desc.	Gas thread
3450000590	176-1/4	1/4" M
3450000600	176-3/8	3/8" M
3450000650	176-1/2	1/2" M

## Valve with female thread



Code	Desc.	Gas thread
3450000690	177-1/4	1/4" F
3450000700	177-3/8	3/8" F

### Valve with spring



Code	Desc.	For spiral
345000350	172-6x8	6x8
345000400	173-8x10	8x10
3450001209	190-10x12	10x12

### Valve with hose connection



Code	Desc.	For spiral
345000800	178-6x14	6x14
345000850	178/1-8x17	8x17
345000860	178/2-10x19	10x19

## SERIE GERMANIA



### Raccordi per aria compressa

#### Coupling with bayonet connection



- For transformation tools by bayonet quick coupling.

Code	Desc.
3450007200	232

#### Coupling with female thread



Code	Desc.	Gas thread
3450009600	274-1/4	1/4" F
3450009650	274-3/8	3/8" F

#### Coupling with hose connection



Code	Desc.	For pipe Ø
3450006700	227-6x14	6x14
3450006800	228-8x17	8x17

## Coupling with male thread



Code	Desc.	Gas thread
3450007900	239-1/4	1/4" M
3450008000	240-3/8	3/8" M
3450008002	240-1/2	1/2" M

## Plug with spring



Code	Desc.	For spiral
3450006900	229-6x8	6x8
3450007000	230-8x10	8x10
3450007100	231-10x12	10x12

## Valve with male thread



Code	Desc.	Gas thread
3450009700	275-1/4	1/4" M
3450009750	275-3/8	3/8" M

## Valve with female thread



Code	Desc.	Gas thread
3450009800	276-1/4	1/4" F
3450009850	276-3/8	3/8" F

## Valve with spring



Code	Desc.	For spiral
3450006400	224-6x8	6x8
3450006500	225-8x10	8x10
3450006600	226-10x12	10x12

## Valve with hose connection



Code	Desc.	For pipe Ø
3450006200	222-6x14	6x14
3450006300	223-8x17	8x17

SERIE GIAPPONE



Raccordi per aria compressa

Coupling with male thread



Code	Desc.	Gas thread
3450005600	216-1/4	1/4" M
3450005700	217-3/8	3/8" M
3450005800	218-1/2	1/2" M

Coupling with female thread



Code	Desc.	Gas thread
3450005900	219-1/4	1/4" F
3450006000	220-3/8	3/8" F
3450006100	221-1/2	1/2" F

Coupling with herringbone

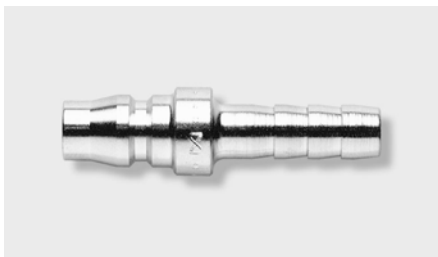

Code	Desc.	For pipe Ø
3450005100	211-6	6
3450005200	212-8	8
3450005300	213-10	10
3450005400	214-12	12
3450005500	215-15	15

Valve with male thread



Code	Desc.	Gas thread
3450004500	205-1/4	1/4" M
3450004600	206-3/8	3/8" M
3450004700	207-1/2	1/2" M

Valve with female thread



Code	Desc.	Gas thread
3450004800	208-1/4	1/4" F
3450004900	209-3/8	3/8" F
3450005000	210-1/2	1/2" F



## Valve with herringbone



Code	Desc.	For pipes Ø int. mm
3450004000	200-6	6
3450004100	201-8	8
3450004200	202-10	10
3450004300	203-12	12
3450004400	204-15	15

## Fittings for compressed air series Japanese giant



Foto 1



Foto 2



Foto 3



Foto 4

- Fittings series in the Japanese giant version, suitable for large air passages for pneumatic tools with large consumption.
- Construction of hardened steel and chrome.
- Extremely high air flow of 3900 liters / minute.
- Perfectly compatible with all fittings series Japan giant of other brands.

Code	Desc.	Article	Photo
3450004410	204 SG	Valve with herringbone diameter 15 mm	1
3450004710	207 SG	Valve male thread 1/2 "	2
3450005510	215 SG	Coupling with herringbone diameter 15 mm	3
3450005810	218 SG	Coupling with male thread 1/2 "	4

Articolo	Attacco/D. tubo	Lungh. tot.	Mis. esagano	Lungh. attacco	Lungh. resca/filettatura
204 SG	15 mm.	83 mm.	29 mm.	/	36 mm.
207 SG	1/2"M	63 mm.	29 mm.	/	16 mm.
215 SG	15 mm.	66 mm.	22 mm.	23 mm.	36 mm.
218 SG	1/2"M	50 mm.	22 mm.	23 mm.	16 mm.

## Air Connections super fast "T"



- Quick coupling automatic.
- Fitting body acetal resin with o-ring steel for food use, passage of nitrogen (N<sub>2</sub>) and anhydrite carbon dioxide (CO<sub>2</sub>).

Code	Desc.	For pipes Ø " mm
1760024400	6540-4	2x4
1760024500	6540-5	3x5
1760024600	6540-6	4x6
1760024700	6540-8	6x8
1760024800	6540-10	8x10

## Super quick couplings air at "L"



- Quick coupling automatic.
- Fitting body acetal resin with o-ring steel for food use, passage of nitrogen (N<sub>2</sub>) and anhydrite carbon dioxide (CO<sub>2</sub>).

Code	Desc.	For pipes Ø " mm
1760025000	6550-4	2x4
1760025100	6550-5	3x5
1760025200	6550-6	4x6
1760025300	6550-8	6x8
1760025400	6550-10	8x10

## Air Connections super fast Rights



- Quick coupling automatic
- Fitting body acetal resin with o-ring steel for food use, passage of nitrogen (n<sub>2</sub>) and anhydrite carbon dioxide (CO<sub>2</sub>).

Code	Desc.	For pipes Ø " mm
1760025600	6580-4	2x4
1760025700	6580-5	3x5
1760025800	6580-6	4x6
1760025900	6580-8	6x8
1760026000	6580-10	8x10
1760026012	6580-12	10x12
1760026014	6580-14	12x14
1760026015	6580-15	12x15
1760026016	6580-16	14x16

## Reduction straight fittings for air super fast

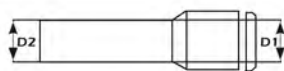

- Quick coupling automatic.
- Fitting body acetal resin with o-ring steel for food use, passage of nitrogen (N<sub>2</sub>) and anhydrite carbon dioxide (CO<sub>2</sub>).

Code	Desc.	Per tubi Ø esterno mm	For pipes Ø int. mm
1760027300	6610-4-6	6	4
1760027301	6610-5-6	6	5
1760027350	6610-4-8	8	4
1760027400	6610-6-8	8	6
1760027450	6610-6-10	10	6
1760027500	6610-8-10	10	8
1760027550	6610-8-12	12	8
1760027551	6610-10-12	12	10

## Air Connections super quick end with BSP (conical)



- Quick coupling automatic
- Fitting body acetal resin with o-ring steel for food use, passage of nitrogen (n<sub>2</sub>) and anhydrite carbon dioxide (CO<sub>2</sub>).

Code	Desc.	For pipes Ø " mm	Thread BSP
1760033010	10400-4-1/4	2x4	1/4
1760033030	10400-5-1/4	3x5	1/4
1760033050	10400-6-1/4	4x6	1/4
1760033070	10400-8-1/4	6x8	1/4
1760033080	10400-8-3/8	6x8	3/8
1760033090	10400-10-1/4	8x10	1/4
1760033100	10400-10-3/8	8x10	3/8
1760033110	10400-10-1/2	8x10	1/2
1760033120	10400-12-3/8	10x12	3/8
1760033130	10400-12-1/2	10x12	1/2
1760033134	10400-18-1/2	16x18	1/2

## Interim reduction straight fittings for air super fast



- Quick connect couplings automatic
- Fitting body acetal resin with o-ring steel for food use, passage of nitrogen (n2) and anhydrite carbon dioxide (CO2)

Code	Desc.	Tubo entrata	Tubo uscita
1760033140	10410-06-04	6	4
1760033150	10410-08-04	8	4
1760033160	10410-08-06	8	6
1760033170	10410-10-06	10	6
1760033180	10410-10-08	10	8
1760033190	10410-12-08	12	8
1760033200	10410-12-10	12	10

## Spigot hose holder for super fast fittings air



- Allows fast connection between fittings with rubber tubes.

Code	Desc.	Ø tubo interno 1	Tang Ø 2
1760033350	10450-6-4	4	6
1760033360	10450-8-6	6	8
1760033370	10450-10-8	8	10

## Terminal shank BSP (conical)



- Allows the assembly of fittings to "L, T" with threaded parts.

Code	Desc.	Tang x diam. pipe	Thread BSP
1760033210	10420-4-1/8	4X6	1/8
1760033220	10420-4-1/4	4X6	1/4
1760033230	10420-5-1/8	5X6	1/8
1760033240	10420-5-1/4	5X6	1/4
1760033250	10420-6-1/8	6X8	1/8
1760033260	10420-6-1/4	6X8	1/4
1760033270	10420-8-1/8	8X10	1/8
1760033280	10420-8-1/4	8X10	1/4
1760033290	10420-8-3/8	8X10	3/8
1760033300	10420-10-1/4	10X12	1/4
1760033310	10420-10-3/8	10X12	3/8
1760033320	10420-10-1/2	10X10	1/2
1760033330	10420-12-3/8	12X14	3/8
1760033340	10420-12-1/2	12X14	1/2

## Elbow with tang



Code	Desc.	For pipe Ø	Tang x diam. pipe
1760033380	10460-04-04	2x4	4X6
1760033390	10460-05-05	3x5	5X6
1760033400	10460-06-06	4x6	6X8
1760033410	10460-08-08	6x8	8X10
1760033420	10460-10-10	8x10	10X12
1760033430	10460-12-12	10x12	12X14

## Bulkhead with chromed ring



Code	Desc.	For pipe Ø
1760033440	10480-04	2x4
1760033450	10480-05	3x5
1760033460	10480-06	4x6
1760033470	10480-08	6x8
1760033480	10480-10	8x10
1760033490	10480-12	10x12

## Air Connections super fast all-brass "T"

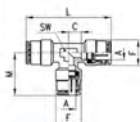

- Quick coupling automatically.
- Fitting body and completely made of brass and stainless attacks.
- Pressure range 0.99 15 bar.

Code	Desc.	For pipes Ø <i>internal</i>	For pipes Ø <i>external</i>
1760024920	6545-4	2	4
1760024930	6545-6	4	6
1760024940	6545-8	6	8
1760024950	6545-10	8	10
1760024900	6545-12	10	12
1760024910	6545-14	12	14

## Air Connections super fast all-brass "L"

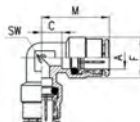

- Quick coupling automatic.
- Fitting body and attacks completely made of brass and steel.
- 15 bar pressure range 0.99.

Code	Desc.	For pipes Ø <i>int. mm</i>	Per tubi Ø <i>esterno mm</i>
1760025520	6555-4	2	4
1760025530	6555-6	4	6
1760025540	6555-8	6	8
1760025550	6555-10	8	10
1760025500	6555-12	10	12
1760025510	6555-14	12	14

## Air Connections super fast all-brass rights

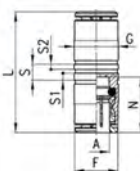

- Quick coupling automatic.
- Fitting body and attacks completely made of brass and steel.
- 15 bar pressure range 0.99.

Code	Desc.	For pipes Ø <i>int. mm</i>	Per tubi Ø <i>esterno mm</i>
1760026120	6545-4	2	4
1760026130	6545-6	4	6
1760026140	6545-8	6	8
1760026150	6545-10	8	10
1760026100	6545-12	10	12
1760026110	6545-14	12	14

## End fittings rights made of brass with O-ring mounted

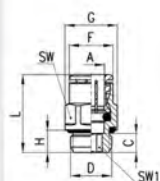

- Type of material: Brass

Code	Desc.	For pipes Ø <i>internal</i>	For pipes Ø <i>external</i>	Gas thread <i>male</i>
1760026919	6510-4-1/8	2	4	1/8"
1760026920	6510-4-1/4	2	4	1/4"
1760026990	6510-6-1/8	4	6	1/8"
1760027000	6510-6-1/4	4	6	1/4"
1760027100	6510-8-1/4	6	8	1/4"
1760027110	6510-8-3/8	6	8	3/8"
1760027115	6510-10-1/4	8	10	1/4"
1760027200	6510-10-3/8	8	10	3/8"
1760027201	6510-12-1/4	10	12	1/4"
1760027202	6510-12-3/8	10	12	3/8"

## The end fittings to "L" swivel with male connection

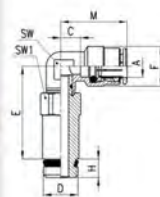

- With o-ring mounted.

Code	Desc.	For pipes Ø <i>external</i>	For pipes Ø <i>internal</i>	Gas thread <i>male</i>
1760026830	6505-6	6	4	1/8"
1760026840	6505-6	6	4	1/4"
1760026845	6505-8	8	6	1/8"
1760026850	6505-8	8	6	1/4"

## End fittings at "T" with O-ring and male coupling

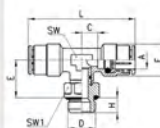

- With o-ring mounted.

Code	Desc.	For pipes Ø <i>external</i>	For pipes Ø <i>internal</i>	Gas thread <i>male</i>
1760027203	6525-4	4	2	1/8"
1760027204	6525-6	6	4	1/8"
1760027205	6525-6	6	4	1/4"
1760027206	6525-8	8	6	1/8"
1760027210	6525-8	8	6	1/4"
1760027220	6525-8	8	6	3/8"
1760027221	6525-10	10	8	1/4"
1760027230	6525-10	10	8	3/8"
1760027231	6525-12	12	10	1/4"
1760027232	6525-12	12	10	3/8"

## Reductions straight

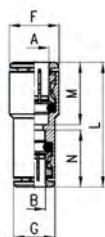

Code	Desc.	For pipes Ø <i>entrance</i>	For pipe Ø <i>exit</i>
1760026200	6525-6-4	6	4
1760026210	6525-8-6	8	6
1760026220	6525-10-8	10	8
1760026221	6525-12-10	12	10



### Swivels to "L" with O-ring

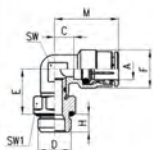

Code	Desc.	For pipes Ø <i>internal</i>	For pipes Ø <i>external</i>	Gas thread <i>male</i>
1760028000	6630-4	2	4	1/8"
1760028010	6630-4	4	6	1/4"
1760028020	6630-6	4	6	1/8"
1760028030	6630-6	4	6	1/4"
1760028040	6630-8	6	8	1/8"
1760028050	6630-8	6	8	1/4"
1760028060	6630-8	6	8	3/8"
1760028070	6630-10	8	10	1/4"
1760028080	6630-10	8	10	3/8"
1760028090	6630-12	10	12	3/8"

### Air Connections super fast cross entirely of brass



Code	Desc.	For pipes Ø <i>external</i>	For pipes Ø <i>internal</i>
1760028100	6631-4	4	2
1760028110	6631-6	6	4
1760028120	6631-8	8	6
1760028130	6631-10	10	8
1760028140	6631-12	12	10

### Bifurcation entirely of brass

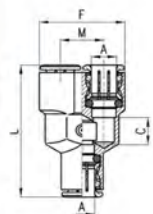

Code	Desc.	For pipes Ø <i>external</i>	For pipes Ø <i>internal</i>
1760028150	6632-4	4	2
1760028160	6632-6	6	4
1760028170	6632-8	8	6
1760028180	6632-10	10	8

## Super quick couplings air at Serie 5000N

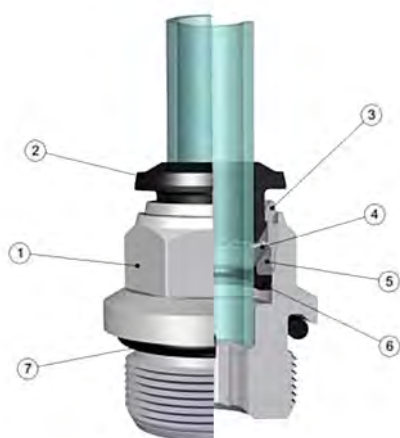

- Air Connections plug super fast built in nickel-plated brass, with forceps stainless steel inner ring and pusher release plastic black. Ideal for the quick connection of pipes in plastic material, usable in any situation for the transfer of pressures or vacuums.
- In particular, they are identical to what mounted by the manufacturers of trucks in the first plant on pneumatic systems braking. That meet very strict technical requirements, easy to assemble and secure the estate. They all have a pre-assembled seals that facilitate the most of their replacement in case of breakage or plant modifications. They resist pressures up to 15 bar and temperatures from -20 ° C to + 80 ° C.
- Used with pipes: PA6, PA11, PA12, Polyethylene, Polyurethane, PTFE, FEP, etc. For use with polyurethane tubing it is recommended to use a hardness of 98 Shore.
- Match threads gas = mm: 1/8 " : 9,73 - 1/4" : 13.16 - 08.03 " : 16.66.

Coppia di serraggio per filettature maschio ISO-228 con OR		
Misura	Coppia consigliata Nm	Coppia di rottura Nm
M5	0,8	3,2
1/8"	3	8
1/4"	9	30
3/8"	10	60

I valori di rottura possono variare in base all'articolo

1. Corpo in ottone nichelato
2. Spintore sgancio tubo in resina acetalica
3. Capsula in ottone nichelato
4. Pinza di aggraffaggio in acciaio inox AISI 301
5. Anello di sicurezza in tecnopolimero
6. Guarnizione a labbro in NBR
7. Guarnizione filetto in NBR

## Fittings and reductions intermediate rights



Code	Desc.	Per tubi Ø esterno mm
1760033500	10490/4	4
1760033510	10490/6	6
1760033520	10490/6-4	6-4
1760033530	10490/8	8
1760033540	10490/8-6	8-6
1760033550	10490/10	10
1760033560	10490/10-8	10-8
1760033570	10490/12	12
1760033580	10490/12-10	12-10
1760033590	10490/14	14

## Intermediate fittings 90 °



Code	Desc.	Per tubi Ø esterno mm
1760033600	10491/4	4
1760033610	10491/6	6
1760033620	10491/8	8
1760033630	10491/10	10
1760033640	10491/12	12
1760033650	10491/14	14

## Intermediate fittings T



Code	Desc.	Per tubi Ø esterno mm
1760033660	1050/4	4
1760033670	1050/6	6
1760033680	1050/8	8
1760033690	1050/10	10
1760033700	1050/12	12
1760033710	1050/14	14

## Tees adjustable threaded cylindrical



Code	Desc.	For pipes Ø ext. mm + thread
1760033720	1051/4	4 mm - 1/4"
1760033730	1051/6-1/8	6 mm - 1/8"
1760033740	1051/6-1/4	6 mm - 1/4"
1760033750	1051/8-1/4	8 mm - 1/4"
1760033760	1051/8-3/8	8 mm - 3/8"
1760033770	1051/10- 1/4	10 mm - 1/4"
1760033780	1051/10-3/8	10 mm - 3/8"
1760033790	1051/12-3/8	12 mm - 3/8"

## Automatic fittings rights with cylindrical thread



Code	Desc.	For pipes Ø ext. mm + thread	Wrench mm
1760033800	1052/4-18	4 mm - 1/8"	10
1760033810	1052/4-1/4	4 mm - 1/4"	10
1760033820	1052/6-1/8	6 mm - 1/8"	13
1760033830	1052/6-1/4	6 mm - 1/4"	13
1760033840	1052/8-1/4	8 mm - 1/4"	14
1760033850	1052/8-3/8	8 mm - 3/8"	14
1760033860	1052/10-1/4	10 mm - 1/4"	17
1760033870	1052/10-3/8	10 mm - 3/8"	17
1760033880	1052/12-3/8	12 mm - 3/8"	20

## 90° swivel fittings with cylindrical thread



Code	Desc.	For pipes Ø ext. mm + thread
1760033900	1053/4-1/8	4 mm - 1/8"
1760033910	1053/6-1/8	6 mm - 1/8"
1760033920	1053/6-1/4	6 mm - 1/4"
1760033930	1053/8-1/4	8 mm - 1/4"
1760033940	1053/8-3/8	8 mm - 3/8"
1760033950	1053/10-1/4	10 mm - 1/4"
1760033960	1053/10-3/8	10 mm - 3/8"
1760033970	1053/12-3/8	12 mm - 3/8"

## Straight fittings with cylindrical thread short



- Fittings with short straight metric threads are used mainly on air diverters.
- Mounting via internal hex 4 mm and 13 mm external hexagon.

Code	Desc.	For pipes Ø ext. mm + thread
1760034000	1054/1	6 mm – M 12X1,00
1760034010	14054/2	6 mm – M 12X1,25
1760034020	1054/3	6 mm – M 12X1,50

## 90° swivel fittings with cylindrical thread short



- Fittings with short straight metric threads are used mainly on air diverters.

Code	Desc.	For pipes Ø ext. mm + thread
1760034030	1055/1	6 mm – M 12X1,00
1760034040	1055/2	6 mm – M 12X1,25
1760034050	1055/3	6 mm – M 12X1,50
1760034060	1055/4	8 mm – M 12X1,50

## Compressors

- New range of portable compressors with a capacity from 0 to 200 litres.
- ABAC brand compressors; company leader in the manufacture of compressors.
- The commercialisation of ABAC compressors allows us to offer our customers a fast service and quick delivery of the products supplied.

### Direct transmission compressor without tank



- Model without lubrication
- Germania series outlet valve
- Easy to handle and transport
- Ideal for blowing, stapling, inflating bicycle or scooter tyres

Code	Description
4430050024	Compy 015 compressor without tank

Tecnical Features	
Peso Kg	4,5
Overall dimensions	280x180x347
Db (A)	97
Pression max (bar)	8
Power supply	230v
R.p.m.	3400
Power output HP	1,5
Power output (Kw)	1,1
Tank capacity	0 lt
Litres/min	180



## Compressor with 6 litre tank



- Model without lubrication
- Germania series outlet valve
- Ideal for blowing, aggraffaggio, inflating bicycle or scooter tyres

Code	Description
4430050026	Start 015 - 6 lt compressor

Technical Features	
Overall dimensions	330x360x350
Peso Kg	9,5
Db (A)	97
Pression max (bar)	8
Power supply	230v
Power output (Kw)	1,1
R.p.m.	3400
Tank capacity	6 lt
Power output HP	1,5
Litres/min	180

## Direct transmission compressor with 24 lt tank



- Model without lubrication
- Germany series outlet valve
- Ideal for blowing, aggraffaggio, spray painting and inflating car tyres

Code	Description
4430050028	Pole Position L20 - 24 lt compressor

Technical Features	
Overall dimensions	570x255x590
Db (A)	94
Pression max (bar)	8
R.p.m.	2850
Power supply	230v
Power output (Kw)	1,5
Tank capacity	24 lt
Power output HP	2
Litres/min	222
Peso Kg	24,6

## Direct transmission compressor with 50 lt tank



- Model without lubrication
- Germany series outlet valve
- Ideal for blowing, aggraffaggio, spray painting and inflating car tyres

Code	Description
4430050031	Montecarlo 020P - 50 lt compressor

Tecnical Features	
Overall dimensions	770x310x645
Db (A)	95
Pression max (bar)	8
R.p.m.	2850
Power supply	230v
Power output (Kw)	1,5
Tank capacity	50 lt
Power output HP	2
Litres/min	230
Peso Kg	30,5

Indicatori di pressione di grandi dimensioni e inclinati per facilitare la lettura

Copertura sicura e resistente

## Single-stage belt transmission compressor with 100 lt tank



- Model with lubrication
- Germany series outlet valve
- Ideal for blowing, grinding, powering screwdrivers, spray painting and inflating car tyres

Code	Description
4430050032	Pro A29B 100 CM2 - 100 lt compressor

Tecnical Features	
Peso Kg	56
Overall dimensions	1010x415x900
Db (A)	93
Pression max (bar)	10
Power supply	230v
R.p.m.	1075
Power output (Kw)	1,5
Power output HP	2
Litres/min	255
Tank capacity	100 lt

## Single-stage belt transmission compressor with 200 lt tank



- Lubricated model
- Germany series outlet valve
- Ideal for blowing, grinding, powering screwdrivers, spray painting and inflating car tyres

Code	Description
4430050033	Pro A39B 200 CM3 – 200 lt compressor

Technical Features	
Peso Kg	91
Overall dimensions	1500x470x1110
Db (A)	93
Pression max (bar)	10
Power supply	230v
R.p.m.	1050
Power output (Kw)	2,2
Power output HP	3
Tank capacity	200 lt
Litres/min	393

## Air blow gun



- Model nylon.
- Air connection 1/4 female gas.

Code	Desc.
3450001298	1150

## Air blow gun barrel length



- Model nylon.
- Barrel length 20 cm.
- Air connection 1/4 female gas.

Code	Desc.
3450001410	1153

## Air blow gun



- Aluminum model.
- Air connection Bayonet.

Code	Desc.
3450001300	1151

## Air blow gun barrel length



- Aluminum model.
- Barrel length 20 cm.
- Air connection Bayonet.

Code	Desc.
3450001400	1152

## Blow gun barrel curve



- Gun resin.
- Rod curve brass.
- Barrel length 110 mm.
- Air connection 1/4 female gas.

Code	Desc.
3450001570	1165

## Blow gun with protection



- Gun resin.
- Curve cane with rubber protection scratch resistant.
- Barrel length 110 mm.
- Air connection Bayonet.

Code	Desc.
3450001560	1163

## Blow gun extra-long barrel



- Gun resin.
- Barrel length 300 mm.
- Air connection 1/4 female gas.

Code	Desc.
3450001555	1162

## Mini compressed air blower



- Practical, reduced dimension compressed air blower
- Supplied with Germania series attachment already mounted
- Air attachment - Gas 1/4" F
- The turbo nozzle dispenses an excellent air flow
- Materials: thermoplastic and metal

Code	Description
3450001579	1169-Mini compressed air blower



## Air kit over the counter



- The kit includes: blowing gun nylon already connected to the spiral polyurethane  $\varnothing$  8x5 4 m long.
- Air connection to the spiral = 1/4 gas female.

Code	Desc.
3450008220	252

## Gun cleaning units



- Aluminum gun with tank painted steel adjustable jet.
- Air connection Bayonet.
- Screw tank capacity 1000 cc.
- Suitable for any type of liquid.

Code	Desc.
3450001505	1156

## Gun cleaning units



- Gun with aluminum tank adjustable jet.
- Air connection Bayonet.
- Tank with quick coupling.
- Fuel tank capacity 1000 cc.
- Suitable for any type of liquid.

Code	Desc.
3450001510	1157

## sandblasting gun



- Body: nickel-plated brass.
- Nozzle: casehardened steel  $\varnothing$  6 mm.
- Dip tube: 2 m,  $\varnothing$  16x22.
- Working pressure: 5-8 bar.
- Air connection Bayonet.
- Gun suitable for cleaning, scraping, removal of rust, paint and dirt resistant. Ideal for the preparation of materials such as wood, steel, aluminum, plastic etc. Used in various sectors: bodywork, industry, carpentry.

Code	Description
3450003800	5999 - Complete gun
345RC3170	317 - Nozzle Replacement

## Caulking gun cartridges



- Pneumatic gun for the application of silicones, sealants and putties in cartridge.
- Length cartridges: min. 192 mm max 225 mm.
- $\varnothing$  cartridges: min. 44 mm max 50 mm.
- Supplied with 3 nozzles of different forms.
- Air connection Bayonet.

Code	Desc.
3450001540	1160

## Thrust buffer for pipe guns



- Thrust pad in plastic. Internal diameter 51 mm. Central hole for hexagon nut of 8 mm.
- Spare parts for guns for sealants in bags.

Code	Desc.
4430055260	1146

## Gun for protection



- Gun for applying monocomponent soundproofing protective polyurethane bases.
- Ideal for protective wax.
- To use with pre-packaged products in milk 1l, you screw thread European.
- Equipped with tube length 600 mm with special nozzle to spray in closed parts.
- Air connection Bayonet.

Code	Desc.
3450001420	1154

## Gun Kit with nozze



- Kit for the application pneumatic of protective wax and soundproof, internal and external.
- Use with products packed in cans 1l, with screw thread and European.
- Air gun with bayonet coupling.
- The kit includes: 1 pistol; 2 suction tubes; 2 nozzles for milk L1.

Code	Desc.
3450003905	6001

## Nozzle kit parts



- Nozzles and suction tubes parts for our art. cod. 345 00 03905-6001.
- Contents: 6 nozzles handgun 6 suction tubes.

Code	Description
3450003912	6002N
3450003910	6002 (old model parts)

## Gun for protection



- Pneumatic gun for soundproofing treatments and protective.
- Suitable for products packed in cans L1 with screw thread for European and bulk.
- Provided with various nozzles and tubes for boxed.
- Air connection Bayonet.

Code	Desc.
3450003917	6004

## Mastic gun spraying and tang



- Pneumatic gun for the application of sealants spray shank for the body.
- Suitable for the use of cartridges from 280/310 ml and produced in the bag.
- Advancement of the bottom of the cartridge plunger.
- Air connection 1/4 male gas.

Code	Desc.
3450003919	6006

## Mini airbrush touch-up



MINI AEROGRAFO AD ALTA PRECISIONE, IDEALE PER LA VERNICIATURA DI PICCOLE SUPERFICI E PER RI-Tocchi. UTILIZZATO IN CARROZZERIA, NELL'INDUSTRIA E NELLA FALCIGNAMERIA.

- Nickel plated brass body.
- Needle and stainless steel nozzle.
- Reservoir gravity shiny aluminum.
- Fuel tank capacity: 125 cc.
- Pressure: 1-3.5 bar.
- Air consumption: 30-60 l / min.
- Nozzle diameter: 0.3-0.5.
- Air connection Bayonet.

Code	Desc.	Ø ugello
3450001210	333	0.3
3450001212	555	0.5

## Standard airbrush



- Nickel plated brass body.
- Needle and stainless steel nozzle.
- Reservoir gravity shiny aluminum.
- Pressure: 3-4.5 bar.
- Air consumption: 200-350 l / min.
- Ø nozzle: 1-1.2-1.4-1.7-1.9-2.2-2.5.
- Air connection Bayonet.
- Airbrushes with tank 1000 cc.
- Airbrush suitable for all painting requirements, a wide range of nozzles and reservoir gravity: 1000 cc.

Code	Desc.	Serbatoio	Ø Ugello mm
3450001218	1012	1000 cc	1
3450001234	1212	1000 cc	1.2
3450001241	1412	1000 cc	1.4
3450001700	1712	1000 cc	1.7
3450002100	1912	1000 cc	1.9
3450002800	2212	1000 cc	2.2
3450003200	2512	1000 cc	2.5

## Replacement Kit for standard spray guns



- The kit includes: needle; nozzle; hat.

Code	Desc.	Ø Ugello mm
345RC01060	144550-4-1.4	1.4
345RC01100	144959-4-2.2	2.2

## Airbrush super



- Nickel plated brass body.
- Needle and stainless steel nozzle.
- Tank suction polished aluminum capacity 1000 cc.
- Closing tank bayonet.
- Pressure: 3-4.5 bar.
- Air consumption: 200-350 l / min ..
- Ø nozzle: 1.2-1.4-1.7-1.9-2.2-2.5.
- Air connection Bayonet.
- Conventional airbrush suitable for various painting requirements, a wide range of nozzles and suction tank.

Code	Desc.	Ø Ugello mm
3450001225	1201	1.2
3450001239	1401	1.4
3450001250	1701	1.7
3450001900	1901	1.9
3450002600	2201	2.2
3450003000	2501	2.5

## Kit parts for airbrushes super



- **The kit includes:** needle; nozzle; hat.

Code	Desc.	Ø Ugello mm
345RC00580	139459-2-1.4	1.4
345RC00590	139556-2-1.7	1.7
345RC00600	139653-2-1.9	1.9
345RC00630	139955-2-2.5	2.5

## Gasket Set, 5 pieces, for tank bayonet



Code	Desc.	Content
345RC00510	136174-2	Seal tank 5 pcs.



## Special airbrush



- Professional spray gun. the balance in internal air passages and hat high pulverization, guarantee a high degree of atomization in any type of use: from the bodywork industry, the carpentry.
- Aluminum body.
- Needle and stainless steel nozzle.
- Hat high sputtering nickel plated brass.
- Pressure regulator air inlet.
- Tank suction polished aluminum, capacity 1000 cc, nylon filter mesh in 5000, closing the autoclave.
- $\emptyset$  nozzle: 1.3-1.5-1.7-1.9-2.2-2.5.
- Pressure: 2.5-5 bar.
- Air consumption: 150 to 340 l / min.
- Air connection Bayonet.

Code	Desc.	$\emptyset$ Ugello mm
3450001224	1200	1.3
3450001238	1400	1.5
3450001249	1700	1.7
3450001800	1900	1.9

## Airbrush to finish "GENESIS S GEO"



- Professional spray gun specifically for use in car body, allows to obtain a high degree of finishing with the new types of paint product. Thanks to a special nozzle with 6 holes, the varnish is pre-atomised inside the same and then be riatomizzata from the air of the beaks of the hat. This system determines: excellent finishing result, reduction of the smoke from 38% to 67% with considerable paint savings and reduced air consumption.
- Hat chemically nickel-plated brass-cally.
- Nozzle: Monobloc stainless steel AISI 303 (high pulverization).
- Forged aluminum body anodized.
- EC marking with serial no.
- Inlet air pressure regulator with gauge.
- Hostaform gravity tank, capacity 680 cc.
- Pressure: 1.5-2.5 bar.
- Air consumption: 200-240 l / min.
- Air connection 1/4 male gas.
- Nozzle diameter: 1.5.

Code	Desc.	$\emptyset$ Ugello mm
3450003920	9000 FXGEO-1,5	1.5
345RC04980	917013H	1.3 Kit FXGEO
345RC05000	936013 - 1,3	Kit FXGEO "GENESIS"

## Gun "Bi-Turbo Cleaner"



- Compressed air gun special for the cleaning of each type of surface and washable fabric. New model with double trumpet vaporization and aspiration to work faster and more effectively.
- Product suitable for bus, truck drivers, car dealers, car dealerships and vehicles, marine, upholstery, assembly and maintenance curtains, outdoor furniture, etc.
- The gun Bi-Turbo Cleaner should be used together with our detergent nanotechnology cod. 411 00 17660 and can degrease, clean and sanitize efficiently textiles, fabrics, plastics and any washable surface. Used with our leather cleaner and imitation leather cod. 411 00 15940-3280 allows deep cleaning of each coating prized.
- Gun made of aluminum and composite material with tank and spray nozzle impact plastic. Controller for opening the flow of detergent, and for closing the suction of the dirt. Nozzle wallet dirt easily removable for cleaning and rinsing. Air connection inlet female threaded 1/4 "gas.
- The cleaning system Meccanocar is practical, easy to use, it does not provide for efforts by the operator and thoroughly cleans the surfaces treated. Content: dispensing gun Bi-Turbo Cleaner, detergent tank cap, air clutch series japan.
- Can be used with detergent nanotechnology (4110017660), leather cleaner and imitation leather (4110015940) and sanitizing liquid disinfectant (41100 5950).
- INSTRUCTIONS: Fill the pan detergent and load the compressor 9 bar.
- Open the cock in vertical position and spray the detergent on the parts to be treated to approximately 1 cm away from the surface. Leave for a second detergent.
- Move the lever in a horizontal position and wipe the surfaces treated with the usual mode. Clean the nozzle in water disassembling or leaving the gun and shaking slightly.

Code	Desc.
4180008400	5980

Spare Parts		
Article	Code	Desc.
Horn Blower plastic	418RC00440	61
Tube with rings of parts	418RC00450	62
With inner tube fitting	418RC00460	63
Seal cap	418RC00470	64
Counterweight with suction filter	418RC00480	65
Horn Blower with steel interior for both models Turbo Cleaner and Bi-Turbo Cleaner	418RC00490	66

## Gun "Turbo Cleaner2"



- The rapid cleaning system " Meccanocar Turbo Cleaner2" allows an intensive cleaning, effective, fast and simple, in a very short time, without operator effort and with high results. The offer includes the use of a particular instrument, the turbo cleaner2 gun, which, combined together with our nanotech specific product allows you to cleanse and clean various surfaces in different applications.
- To special compressed air gun for cleaning any type of surface and washable fabric.
- Product suitable for bus, truck drivers, car dealers, car dealerships and V.I, marine, upholstery, curtains, installation and maintenance, outdoor furniture, etc.
- The gun Turbo Cleaner2 should be used together with our detergent nanotechnology cod. 411 00 17660 and allows to degrease, cleanse and sanitize efficiently fabrics, plastics and any washable surface. Used with our cleaner for leather and imitation leather cod. 411 00 15940- 3280 allows thorough cleaning of each fine coating.
- The version "2" of Turbo Cleaner gun is always constructed entirely of aluminum, with an embossed surface and handle covered by a rubber protection which ensures insulation from cold and vibration damping. Equipped with a controller for opening the flow of detergent, and for closing of the dirt suction nozzle wallet dirt easily removable for cleaning and rinsing, threaded inlet air attack female 1/4 "gas.
- The cleaning system Meccanocar Turbo Cleaner2 and 'practical, easy to use, does not require efforts by the operator and thoroughly cleans the treated surfaces. Contents: Turbo Cleaner2 dispensing gun with 500 ml tank, cap for detergent tank, grafting air japan series.
- Can be used with detergent Nanocleaner (411 00 17660), detergent for leather and artificial leather (411 00 15940) and odor neutralizer (411 00 15950).
- HOW TO USE:
- Fill the detergent tray and load the compressor 9 bar (photo 1).
- Open the valve in an upright position and spray the detergent on the parts to be treated to approximately 1 cm away from the surface 10. (Photo 2).
- Leave on for a few seconds the detergent.
- Move the valve lever in a horizontal position, and wipe the surfaces treated with the usual mode (Figure 3).
- Clean the nozzle by removing it in water or leaving it on the gun waving and dipping it in a container of water.



Code	Desc.
4180007910	5703/2

Spare Parts		
Code	Description	Photo
418RC00190	6-Trumpet only white model for 4180007900-5703	1
418RC00200	7-tube with connected rings	2
418RC00201	7 / A - Tube interior with fitting	3
418RC00210	8- transparent tank with cap	4
418RC00315	40- tap for detergent	5
418RC00480	65 - Counterweight with tube for suction filter	6
418RC00640	81- Red Trumpet only for model 4180007910-5703 / 2	8
418RC00490	66-Trumpet white with internal steel only for model 4180007900-5703	7

## Trombetta plastic with steel reinforcement



Code	Desc.
418RC00490	66

## “Nano Cleaner” system cleaner for quick cleaning



- Nanotechnological detergent for use with turbo gun cleaner.
- The product uses nanotechnological particles to obtain a deep cleaning inside the tissues with low foaming.
- Nanocleaner gets great results on all surfaces such as fabric upholstered seats, carpets, convertible roofs, awnings, etc. ..
- Besides a remarkable cleanliness of the fabric surfaces, nanocleaner brightens colors also releasing a pleasant fragrance.
- Nanocleaner can be used pure in the case of very dirty surfaces or diluted in water in ratio 1 to 2 (1 lt of product in 2 liters of water). Use according to the instructions inside the gun cleaner turbo code. 418 00 07800-5702.

Code	Desc.	Content It
4110017660	4460	5



## Impact wrench 1/2 "Mini-7 850 Nm



- Mini screwdrivers double hammer mechanism, with square drive for sockets reinforced 1/2 ".
- Suitable for all machine shops, tire shops, body shops, for assembly of metallic carpentry, etc..
- Tools with body in composite material, light and insulated from the cold, balanced grip and fatigue-free, small size for working in confined spaces.
- Powerful motor to 7 blades with maximum torque of 850 Nm, torque control of three positions in the tightening. Maximum speed of 8200 rev / min, maximum air consumption 470 liters / minute.
- It comes with air fitting series Japan our code 345 00 05600.

Code	Desc.
4180008340	5930

Spare Parts		
Article	Code	Description
Metal ring sealing sleeves	418RC00350	47
Complete kit of spare palette	418RC00380	53

DATI TECNICI											
Alt. Fil	Quadro	Coppia		RPM	Peso	Ø Int. Tubo Consigliato	Max. Pressione	Consumo Aria	LpA	Vibrazioni	
Inch	Inch	Min	Max	Min <sup>1</sup>	Kg	mm	Bar	L/Min	db (A)	m/s <sup>2</sup>	
1/4	1/2	390	850	11200	1,2	8	6,3	Min 210	Max 650	83,5	3,6

## Impact wrench 1/2" - 850 Nm "Compact2"



- Modern impact wrench with square drive 1/2 " , size and weight and maximum torque of 850 Nm.
- Suitable for professionals who constantly use this type of machine: tire shops, auto mechanics, assemblers, assembly lines, etc.
- Machine body made entirely of aluminum with non-slip paint coating and anti-cold, ability to adjust the torque of the three positions in screwing and unscrewing, type impact mechanism "Jumbo", and sealed at very low maintenance.
- The limited length allows it to be used even in very confined spaces and centers the weight on the handle of the tool, in order not to tire the operator even after long working time.
- 8800 rpm maximum speed per minute, maximum air consumption 550 liters per minute.
- Supplied as standard with Japan series air connection n/s code 3450005600-1/4M

Code	Desc.
4180008510	6020

UTILIZZARE SOLO BUSSOLE RINFORZATE

Spare Parts		
Article	Code	Desc.
Metallic ring seal 1/2"	418RC00350	47
Full small shovel of parts kits	418RC00590	76

DATI TECNICI												
Alt. Fil	Quadro	Coppia		RPM	Peso	Ø Int. Tubo Consigliato	Max. Pressione	Consumo Aria	LWA	LpA	Vibrazioni	
Inch	Inch	Min	Max	Min <sup>1</sup>	Kg	mm	Bar	L/Min	db (A)	db (A)	m/s <sup>2</sup>	
1/4	1/2	420	850	9000	2,4	8	6,3	Min 135	Max 540	95,0	4,40	<12,0



## Impact wrench 1/2 "



- Screwdrivers blowback single (rod-in-magic), with square drive for sockets reinforced 1/2 ".
- Ergonomic handle and centered to a perfect balance.
- The maximum torque of 580 nm makes it ideal for usage on the machine shops, tire shops, metal construction, maintenance workshops.
- Adjusting the power of four positions, exhaust air from the handle, cast aluminum painted black embossed slip.
- Supplied as standard with Japan series air connection n / s code 3450005600-1 / 4M

Code	Desc.
4180004000	5650



**UTILIZZARE SOLO BUSSOLE RINFORZATE**



Spare Parts		
Code	Description	Position split
418RC00350	47 - RING SEAL METAL	8
418RC00225	23 - KIT SCOOPS	22
418RC00216	14- COUPLE PLUGS	11
418RC00220	BASE CAM	13

DATI TECNICI												
Alt. Fil.	Quadro	Coppia		RPM	Peso	Ø Int. Tubo Consigliato	Max. Pressione	Consumo Aria	LWA	LpA	Vibrazioni	
Inch	Inch	Nm	Min <sup>1</sup>	Kg	mm	Bar	L/Min	db (A)	db (A)	m/s <sup>2</sup>		
1/4	1/2	Min 406	Max 580	7800	2,4	8	6,3	Min 130	Max 350	87,4	6,70	<2,5

## Impact wrench 1/2 "Ultra-7



- Impact wrench composite, double-hammer mechanism and powerful engine, square drive tool 1/2 ".
- Suitable for all types of machining onerous repair shops, tire shops, body shops, and assembly of structural steelwork.
- The composite material makes it light and does not transmit the cold, the pistol shape is balanced so as not to tire the operator, low vibration transmission, torque control in screwing, exhaust air handle.
- Maximum torque in unscrewing of 1250 nm, maximum speed 8000 rpm, air consumption of 750 liters / minute.
- Supplied as standard with Japan series air connection n / s code 3450005600-1 / 4M

Code	Desc.
4180008330	5920



DUOPACT

**UTILIZZARE SOLO BUSSOLE RINFORZATE**

Spare Parts	
Code	Description
418RC00350	47-Metal ring seal 1/2 "
418RC00365	50-Kit palette parts 7 pieces

DATI TECNICI												
Alt. Fil.	Quadro	Coppia		RPM	Peso	Ø Int. Tubo Consigliato	Max. Pressione	Consumo Aria	LWA	LpA	Vibrazioni	
Inch	Inch	Nm	Min <sup>1</sup>	Kg	mm	Bar	L/Min	db (A)	db (A)	m/s <sup>2</sup>		
1/4	1/2	Min 900	Max 1280	8200	2,0	8	6,3	Min 240	Max 750	93,0	8,50	9,2

## Impact wrench composite pulse 3/4" "Midi" - 1500 Nm



- Modern impact wrench with square drive 3/4", in size and limited weight, comparable to the keys 1/2", and maximum torque of 1500 Nm.
- Excellent for medium / small-sized work, offers the possibility of use of compasses Measuring greater than 1/2" without having to use adapters. Suitable for professionals who need a lightweight and compact machine, capable of entering into small spaces and manageable for long periods without tiring.
- Machine body made of non-slip composite material and anti-cold with less exhaust, aluminum front body. ability to adjust the torque of the three positions in screwing and unscrewing, double hammer impact mechanism.
- The limited length allows it to be used even in very confined spaces and centers the weight on the handle of the tool, in order not to tire the operator even after long working time.
- Maximum speed 5600 rpm, maximum air consumption of 780 liters per minute.
- Supplied as standard with Japan series air connection n / s code

Code	Description
4180008520	6030

Spare Parts		
Article	Code	Desc.
Metallic ring seal 3/4"	418RC00530	70
Full small shovel of parts kits	418RC00365	50

DATI TECNICI											
Alt. Fil	Quadro	Coppia		RPM	Peso	Ø Int. Tubo Consigliato	Max. Pressione	Consumo Aria		LpA	Vibrazioni
Inch	Inch	Min	Max	Min <sup>-1</sup>	Kg	mm	Bar	L/Min		db (A)	m/s <sup>2</sup>
1/4"	3/4"	1100	1500	5500	2,2	10	6,3	Min	Max	93,0	8,50
								255	780		

## Composite impact wrench 3/4" - 2130 Nm



- Avvitatore pneumatico con corpo in materiale composito leggero, bilanciato e potente, con attacco quadro da 3/4", indicato per lavorazioni medio pesanti gravose come montaggio/smontaggio di viti di grandi dimensioni e su mezzi commerciali e pesanti.
- Utilizzo tipico in officine meccaniche di mezzi pesanti, movimento terra, macchinari per edilizia, da cava, manutenzioni varie, ecc.
- Il corpo macchina in materiale composito è estremamente robusto e resistente agli urti, isola le mani dell'operatore dal freddo e dalle vibrazioni eccessive, l'impugnatura centrale bilancia perfettamente il peso e diminuisce la fatica.
- Scarico aria nell'impugnatura lontano dalla zona di lavoro. Massa battente con meccanismo a doppio martello per uno sviluppo della coppia graduale, regolazione della velocità e della coppia nella parte posteriore della macchina su tre posizioni.
- Foro di ingrassaggio della meccanica nella parte anteriore dell'avvitatore.
- Supplied as standard with Japan series air connection n / s code 3450005700-3 / 8M

Code	Description
4180008360	5950

DATI TECNICI												
Alt. Fil	Quadro	Coppia		RPM	Peso	Ø Int. Tubo Consigliato	Max. Pressione	Consumo Aria		LWA	LpA	Vibrazioni
Inch	Inch	Min	Max	Min <sup>-1</sup>	Kg	mm	Bar	L/Min		db (A)	db (A)	m/s <sup>2</sup>
3/8"	3/4"	1550	2130	5700	3,4	13	6,3	Min	Max		89,5	14,3
								255	970			

## Composite impact wrench 3/4" extended stem 1950 Nm



- Air screwdrivers with lightweight composite body, balanced and powerful, with square 3/4 "and extended shaft, designed for medium demanding heavy machining operations such as assembly / disassembly large screws and heavy commercial vehicles.
- Typical use in machine shops of trucks, earthmoving, general maintenance, etc..
- The body of composite material is extremely robust and shock resistant, island operator's hands from the cold and excessive vibration. The central grip perfectly balances the weight and decreases fatigue. Air exhaust through away from the work area.
- Mass swing with double hammer mechanism for a development of the gradual torque, speed control and torque in the rear of the machine on three positions. Hole greasing the mechanical in the front of the tool. Weight 3.74 kg, air consumption 972 liters / minute.
- **USE ONLY BUSH REINFORCED**
- Supplied as standard with Japan series air connection cod. 3450005700-3 / 8M

Code	Desc.
4180008410	5990

Technical Features	
Air inlet thread	3/8" gas female
Impact mechanism system	Twinhammer
Sound emission	97 dB(A)
Vibrations (m/s <sup>2</sup> )	14,5 m/s <sup>2</sup>
Maximum torque	1950 Nm
Max air consumption	972 liters/minute
Average air consumption (l/min)	255 l/min
Dimensions	374 x 84 x 199 mm
Minimum air supply hose size (mm)	13 mm
Weight	3,74 Kg
max torque (RPM)	6000 RPM
Couple working	1300 Nm
Square connection	3/4"

## Impact wrench 1 "- 2460 Nm



- Screwdrivers with light alloy body, balanced and powerful, with square drive 1 ", for working medium heavy heavy as assembly / disassembly of large screws and commercial vehicles and heavy.
- Typical use in machine shops trucks, earth moving machinery for construction, quarry, general maintenance, etc..
- The machine body entirely in light alloy is extremely robust and shock resistant, the central grip perfectly balances the weight and decreases the fatigue, the supplementary helps the operator to support the machine and center it on the workpiece. Exhaust air in the handle away from the working area.
- Striking mass with double hammer mechanism for a development of the couple gradual adjustment of the speed and torque at the rear of the machine on three positions. Lubrication hole mechanics in the front of the tool.
- Supplied as standard with Japan series air connection cod. 3450005800-1 / 2M

Code	Description
4180008370	5960

DATI TECNICI											
Att. Fil.	Quadro	Coppia	RPM	Peso	Ø int. Tubo Consigliato	Max. Pressione	Consumo Aria	LWA	LpA	Vibrazioni	
Inch	Inch	Nm	Min <sup>1</sup>	Kg	mm	Bar	L/Min	db (A)	db (A)	m/s <sup>2</sup>	
1/2"	1"	Min 1950 Max 2460	5750	10,7	13	6,3	Min 1020 Max 1300	96,80	92,55	13,40	



## Screwdriver heavy pulses 1" extended stem 2900 Nm



- Air screwdrivers with light alloy body, balanced and powerful, with square drive 1" and extended shank, suitable for demanding heavy machining operations such as assembly / disassembly of large screws and heavy commercial vehicles.
- Typical use in machine shops of heavy equipment, construction equipment, construction machinery, quarry, general maintenance, etc...
- The body entirely in light alloy machine is extremely robust and shock resistant, the rear handle and that extra help the operator to support the machine and center it on the workpiece. Air exhaust through away from the work area.
- Mass swing hammer mechanism maintenance, speed control and torque control of three positions. Weight 11.6 Kg, maximum air consumption 1150 liters / minute.
- **USE ONLY BUSH REINFORCED**
- Supplied as standard with Japan series air connection cod. 3450005800-1 / 2M

Code	Desc.
4180008380	5970



Tecnical Features	
Sound emission	100 dB(A)
Vibrations (m/s <sup>2</sup> )	7,8 m/s <sup>2</sup>
Couple working	2000 Nm
Maximum torque	2900 Nm
max torque (RPM)	5150 RPM
Weight	11,6 Kg
Minimum air supply hose size (mm)	13 mm
Dimensions	520 x 186 x 130 mm
Impact mechanism system	Close
Air inlet thread	1/2" gas female
Max air consumption	1150 liters / minute
Average air consumption (l/min)	370 L/min
Square connection	1

## Filters-oilers lubricators in line



COD.418RC00400

COD.418RC00390

Code	Description	Dimensions mm	Air entrance	Uscita aria
418RC00390	55	71 X Ø 43	3/8" F - (1/2" M)	3/8" F - (1/2" M)
418RC00400	57	50 X Ø 33	1/4" F	1/4" M

### Mini power regulator 1/4 "



- Mini flow regulator for pneumatic tools with air inlet 1/4" female. It is easily applied on any type of machine and adjusts the power and speed on the fly.
- Profit for the proper use of all the tools mounted on machines that do not have standard speed control. Built entirely of brass, air inlet female threaded 1/4" male threaded outlet 1/4".

Code	Description	Dimensions mm
418RC00410	58	30x20

### Mini grease gun for impact hammers



- Mini grease gun metal, professional, micro-nozzle designed specifically for the maintenance of impact hammers pneumatic tools.
- Tank of 100 grams, small and handy. Outside diameter 43 mm, height 145 mm.
- Supplied without fat, to be inserted manually.



Code	Desc.
418RC00370	51



## Pneumatic reversible ratchet 1/4 "



- Reversible ratchet small and handy for work in tight spaces. Square drive 1/4 ".
- Command survivor's tool head.
- Exhausted air flow rear and adjustable.
- Loop power adjustment on the back.
- Handgrip composite grip.
- Ideal for automotive, motorcycle and maintenance.
- Supplied as standard with Japan series air connection cod. 3450005600-1 / 4M

Code	Desc.
4180008220	5810

DATI TECNICI												
Att. Fil	Quadro	Coppia		RPM	Peso	Ø Int. Tubo Consigliato	Max. Pressione	Consumo Aria	LWA	LpA	Vibrazioni	
Inch	Inch	Min	Max	Min <sup>1</sup>	Kg	mm	Bar	L/Min	db (A)	db (A)	m/s <sup>2</sup>	
1/4	1/4	22	55	320	0,75	8	6,3	Min 160	Max 500	-	82,2	2,7

## Pneumatic reversible ratchet 3/8 "



- Reversible ratchet small, handy for working in tight spaces.
- Square drive 3/8 ".
- Command survivor's tool head, rear exhaust, handgrip composite material, rubber coating of the head, scratch.
- It equipped with adjustable torque in screwing and unscrewing.
- Ideal for automotive, motorcycle and maintenance.
- Supplied as standard with Japan series air connection cod. 3450005600-1 / 4M

Code	Desc.
4180007000	5694

DATI TECNICI												
Att. Fil	Quadro	Coppia		RPM	Peso	Ø Int. Tubo Consigliato	Max. Pressione	Consumo Aria	LWA	LpA	Vibrazioni	
Inch	Inch	Min	Max	Min <sup>1</sup>	Kg	mm	Bar	L/Min	db (A)	db (A)	m/s <sup>2</sup>	
1/4	3/8	34	34	270	0,60	6	6,3	Min 113	Max 600	-	88	2,8

## Pneumatic reversible ratchet 1/2 "



- Reversible ratchet with square 1/2 "
- Command survivor's head.
- Exhausted air flow, at the center of the tool body.
- Grip composite slip.
- Ideal for automotive, motorcycle and maintenance.
- Supplied as standard with Japan series air connection cod. 3450005600-1 / 4M

Code	Desc.
4180008210	5800

DATI TECNICI											
Att. Fil	Quadro	Coppia		RPM	Peso	Ø Int. Tubo Consigliato	Max. Pressione	Consumo Aria	LWA	LpA	Vibrazioni
Inch	Inch	Nm	Min	Max	Kg	mm	Bar	L/Min	db (A)	db (A)	m/s <sup>2</sup>
1/4	1/2	60	90	220	1,25	8	6,3	Min 220		87,2	<2,5
								Max 660			

## Pneumatic drill spindle max 10mm reversible



- Compact and lightweight pneumatic drill, of high power, for all drilling operations in each material.
- Maximum capacity of opening spindle 10mm., metal body with special coating for anti-skid paint, keyless chuck, exhaust air from under the handle.
- Supplied as standard with Japan series air connection cod. 3450005600-1 / 4M

Code	Desc.
4180008260	5850

Spare Parts		
Code	Description	Features
417RC02185	150-1/10	Spindle parts

DATI TECNICI											
Att. Fil	Mandri no	Potenza	RPM	Peso	Ø Int. Tubo Consigliato	Max. Pressione	Consumo Aria	LWA	LpA	Vibrazioni	
Inch	mm	Watt	Min <sup>-1</sup>	Kg	mm	Bar	L/Min	db (A)	db (A)	m/s <sup>2</sup>	
1/4	Ø 1-10	500	2200	0,95	8	6,3	Min 470		94,2	81,2	2,7
							Max 520				

## Reversible air drill chuck 13 mm max



- Pneumatic drill sturdy and easy to handle, high power, for all the operations of drilling in each material.
- Reversibility for use also as a screwdriver at high power.
- Maximum capacity of opening spindle of 13 mm., Body in shiny metal, keyless chuck, exhaust air from under the handle.
- It equipped as standard with additional handle for safe use also under considerable strain.
- Supplied as standard with Japan series air connection cod. 3450005600-1 / 4M

Code	Desc.
4180005500	5672

Spare Parts		
Code	Description	Features
417RC00085	2-1.5/13	Spindle parts 3 / 8X24 UNF

DATI TECNICI											
Alt. Fil	Mandri no	Potenza	RPM	Peso	Ø Int. Tubo Consigliato	Max. Pressione	Consumo Aria	LWA	LpA	Vibrazioni	
Inch	mm	Watt	Min <sup>-1</sup>	Kg	mm	Bar	L/Min	db (A)	db (A)	m/s <sup>2</sup>	
1/4	Ø 1,5-13	500	800	1,40	8	6,3	Min 585	Max 650	94,9	81,9	2,4

## Grinder straight composite yoke 6 mm



- Mini straight grinder of smaller dimension but by the great power, with the collet 6 mm for use with milling cutters and grinding wheels in any working field.
- Can be used in crafts in both industry for working on metal, wood, plastic materials, grinding operations, mechanical field, processing of fibers, etc.
- The construction of composite material allows the machine to be very light, isolated from the cold, and the ergonomic design makes it very easy to handle, sturdy, non-slip.
- Equipped with rear exhaust swiveling and adjusting the speed of rotation on the handle.
- Supplied as standard with Japan series air connection cod. 3450005600-1 / 4M

Code	Description
4180006700	5691

DATI TECNICI											
Alt. Fil	Albero	Potenza	RPM	Peso	Ø Int. Tubo Consigliato	Max. Pressione	Consumo Aria	LWA	LpA	Vibrazioni	
Inch	mm	Watt	Min <sup>-1</sup>	Kg	mm	Bar	L/Min	db (A)	db (A)	m/s <sup>2</sup>	
1/4	6	300	26000	0,4	8	6,3	Min 415	Max 490	95,1	82,1	<2,5



## Maxi straight grinder



- Straight pneumatic grinder with speed adjustment using a selector.
- Excellent comfort with high power levels, 0.5 HP
- Ideal for heavy-duty grinding.
- Can be used with hard metal or corundum cutters, and all abrasives
- fitted on 6 mm shank
- Complete with pre-fitted lubricator for automatic oil dosage
- Transparent oil tank for level control
- Starter lever with safety.
- Supplied as standard with Japan series air connection cod. 3450005600-1 / 4M

Code	Description
4180008800	6051- Maxi straight grinder

DATI TECNICI										
Alt. Fil	Pinza	Potenza	RPM	Peso	Ø Int. Tubo Consigliato	Max. Pressione	Consumo Aria	LpA	Vibrazioni	
			N <sub>2</sub>							
Inch	mm	HP	Min <sup>-1</sup>	Kg	mm	Bar	L/Min	db (A)	m/s <sup>2</sup>	
1/4 F	6	0,5	22000	0,48	8	6,3	Min 340	Max 415	82,1	< 2,5 m/s <sup>2</sup>

## Angle Grinder 125 mm



- Pneumatic angle grinder for deburring and cutting discs 115 and 125 mm.
- Securing discs via threaded flange M14 female, rear exhaust, metal body with special anti-slip coating in black patent leather embossed.
- Standard with additional handle and cap spark.
- Supplied as standard with Japan series air connection cod. 3450005600-1 / 4M

Code	Desc.
4180005200	5668



DATI TECNICI										DISCHI VELCRATI		
Alt. Fil	Albero	Potenza	RPM	Peso	Ø Int. Tubo Consigliato	Max. Pressione	Consumo Aria	LWA	LpA	Vibrazioni	CODICE	DESCRIZIONE
			N <sub>2</sub>								<b>340 00 XXXXX</b> <b>340 01 XXXXX</b>	<b>Dischi da taglio</b>
Inch	Spindle	Disc	Watt	Min <sup>-1</sup>	Kg	mm	Bar	L/Min	db (A)	db (A)	<b>341 00 XXXXX</b>	<b>Dischi da smeriglio</b>
1/4	M14X2,0 AG	22X100	750	10000	1,6	8	6,3	Min 650	Max 700	95,3	82,3	<b>Dischi lamellari</b>

## Remove protective / canceller pneumatic



- Handy and versatile tool with multiple uses, suitable for removing rust, old paint, coatings sound-, antirust, etc..
- By mounting the toothed disc, rubber can remove old adhesive from plates, plastic parts, glass, crystal, without heating or deform media for reuse.
- Available a great variety of brushes for adaptation to the job.
- Body of lightweight material and non-slip, progressive actuation lever to adjust the speed of the brushes, rear exhaust, additional handle for greater safety during machining operations.
- Bundled with 3 brushes coarse, our code RC 418 00100-3 / G, 1 brush, fine-grained, our code RC 418 00120-3 / F, 1 disc, rubber, Our markup 418 RC 00140-3 / R, all in cardboard box.
- Supplied as standard with Japan series air connection cod. 3450005600-1 / 4M

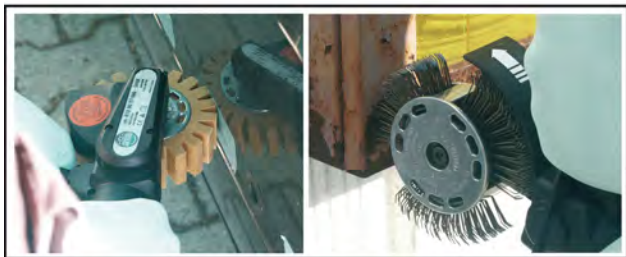
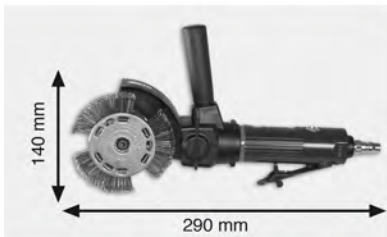

### DATI TECNICI

Att. Fil	Albero	RPM	Peso	Ø Int. Tubo Consigliato	Max. Pressione	Consumo Aria	LWA	LpA	Vibrazioni
Inch	mm	Min <sup>1</sup>	Kg	mm	Bar	L/Min	db (A)	db (A)	m/s <sup>2</sup>
1/4	6	3500	1,1	9,5	6,3	Min Med Max - 110 -	99	88	2,8



Code	Desc.
4180007400	5698

Spare Parts		
Article	Code	Description
Brush large underbody, mastics, deadening, tar sealants. Sandblasted	418RC00100	3/G
Brush average rust deadening. Sandblasted	418RC00110	3/M
Fine brush to paint, antirust, cleaning welds, cleaning sheets.	418RC00120	3/M
Special steel brush to remove paint from aluminum sheet metal.	418RC00130	3/I
Hard screed, rubber adhesive removers, adhesive tape, adhesive strips.	418RC00140	3/R
Flange brushes	418RC00150	3/F
Belt radiator red	418RC00170	5/R
Belt blue radiator	418RC00180	5/B



## Belt grinder straight 10mm



- Compact, lightweight and handy tool for grinding operations, deburring, scraping and sanding in difficult and hard to reach places.
- Tilt adjustable belt of 360 °, fast and simple replacement of the abrasive, metal body with special paint coating embossed slip.
- Rear exhaust.
- Dimensions of the tapes: 330 x 10 mm.
- Bundled with No. 1 tape 80 grit.
- Supplied as standard with Japan series air connection cod. 3450005600-1 / 4M

Code	Desc.
4180007200	5696

Spare Parts		
Article	Code	Description
330x10 tape 40 grit zirconia	418RC00005	1/40
330x10 tape 60 grit zirconia	418RC00008	1/60
330x10 tape 80 grit zirconia	418RC00010	1/80
330x10 tape 120 grit zirconia	418RC00020	1/120
330x10 tape 180 grit zirconia	418RC00030	1/180
330x10 tape 240 grit zirconia	418RC00040	1/240
Front wheel	418RC00305	38

DATI TECNICI									
Att. Fil.	Nastro	RPM	Peso	Ø Int. Tubo Consigliato	Max. Pressione	Consumo Aria	LWA	LpA	Vibrazioni
		N <sub>o</sub>	Kg						
Inch	mm	Min <sup>-1</sup>	Kg	mm	Bar	L/Min	db (A)	db (A)	m/s <sup>2</sup>
1/4 IG	10X330	18000	0,8	8	6,3	Min 520	92,4	79,4	<2,5
						Max 570			

## Belt grinder straight 20 mm



- Compact, lightweight and handy tool for grinding operations, deburring, scraping and sanding in difficult and hard to reach places.
- Tilt adjustable belt of 360 °, fast and simple replacement of the abrasive, metal body with special paint coating embossed slip.
- Rear exhaust.
- Dimensions of the tapes: 520 x 20 mm.
- Bundled with No. 1 tape 80 grit.
- Fornito di serie con connexiono aria seria giappone cod. 3450005600-1 / 4M

Code	Desc.
4180007300	5697

Spare Parts		
Article	Code	Description
520 x 20 Tape 40 grit zirconia	418RC00045	2/40
520 x 20 Tape 60 grit zirconia	418RC00048	2/60
520 x 20 Tape 80 grit zirconia	418RC00050	2/80
520 x 20 Tape 120 grit zirconia	418RC00060	2/120
520 x 20 Tape 180 grit zirconia	418RC00070	2/180
520 x 20 Tape 240 grit zirconia	418RC00080	2/240

DATI TECNICI									
Att. Fil.	Nastro	RPM	Peso	Ø Int. Tubo Consigliato	Max. Pressione	Consumo Aria	LWA	LpA	Vibrazioni
		N <sub>o</sub>	Kg						
Inch	mm	Min <sup>-1</sup>	Kg	mm	Bar	L/Min	db (A)	db (A)	m/s <sup>2</sup>
1/4 IG	20X520	17000	1,15	8	6,3	Min 520	91	78	<2,5
						Max 570			

## Pneumatic random orbital sander



- Roto-orbital sander high performance, for sanding simple and fast to all body parts.
- Amplitude of the orbit of 5 mm. Adjusting simple and intuitive of the rotation speed tramiteuna lever on the handle easily accessible.
- Ergonomically correct Handgrip for less fatigue, head of the coating, preparation for dust extraction.
- Reduced vibration for safeguarding the health of the operator is not causing nerve damage carpal.
- Attack pad threaded 5/16 "female.
- Exclusive speed controller in the handle.
- It allows adjustment even during operation.
- Supplied with pad 15 holes.
- Supplied as standard with Japan series air connection cod. 3450005600-1 / 4M

PLATORELLI ATTACCO VELCRO				
CODICE	DESC.	N° FORI	DIAM. mm	FILETTO
342 01 00400	20	NESSUNO	150	5/16" MASCHIO
342 01 00500	66/7	6+1	150	5/16" MASCHIO
342 01 00600	66/9	8+1	150	5/16" MASCHIO
342 01 02075	66/21	20+1	150	5/16" MASCHIO + BAIONETTA PER "FESTO"

Code	Desc.
4180008270	5860

DISCHI VELCRATI		
CODICE	N° FORI	ATTACCO
334 00 XXXXX	NESSUNO	VELCRO
334 01 XXXXX	6+1	VELCRO
334 02 XXXXX	8+9	VELCRO
334 06 XXXXX	14+1	VELCRO

DATI TECNICI											
Att. Fil	Platorello	Orbita	RPM	Peso	Ø Int. Tubo Consigliato	Max. Pressione	Consumo Aria	LWA	LpA	Vibrazioni	
			N <sub>6</sub>								
Inch	Ø-Filetto	mm	Min <sup>-1</sup>	Kg	mm	Bar	L/Min	db (A)	db (A)	m/s <sup>2</sup>	
1/4	125-150	5	12000	0,8	8	6,3	Min 410	Max 550	-	78	<2,5

## Mini sander angle clamp 6 mm



- Utensil by the small size but by the great power, with the collet 6 mm for use with milling cutters, serrated roller, sanding pads with shank 6 mm for diskettes, etc.
- Can be used in crafts in both industry for working on metal, wood, plastics, sanding and grinding, for the correction of defects on autocarrozzerie, by removal of material in hidden points.
- Construction completely in light alloy with coating machine oil-resistant and non-slip, head with reference to 90 ° with a lubrication hole for the inner mechanical, adjustment of speed on the machine body for the best use of each type of abrasive. Rear exhaust.
- Supplied as standard with Japan series air connection cod. 3450005600-1 / 4M

Code	Description
4180007100	5695

DATI TECNICI											
Att. Fil	Albero	Potenza	RPM	Peso	Ø Int. Tubo Consigliato	Max. Pressione	Consumo Aria	LWA	LpA	Vibrazioni	
			N <sub>6</sub>								
Inch	mm	Watt	Min <sup>-1</sup>	Kg	mm	Bar	L/Min	db (A)	db (A)	m/s <sup>2</sup>	
1/4	6	300	15000	0,55	8	6,3	Min 320	Max 380	-	85,1	<2,5

DISCHI E PLATORELLI	
DESCRIZIONE	CODICE
Dischetti abrasivi ad attacco rapido	494 00 XXXXX
Dischetti a filo abrasivo	493 00 XXXXX
Mini dischetti lamellari 50mm attacco rapido	337 01 XXXXX
Platorelli con attacco rapido a vite	342 01 XXXXX

## Mini random orbital sander 75 mm



- Random orbital sander latest generation for use with discs of small diameter, max 75 mm, ideal for sanding operations on small parts and in confined spaces, where are required high quality finishes.
- Used successfully in the areas of the body, metal working and wood.
- Particularly suitable in combination with our repair kits headlights code 411 00 18010-4645.
- Robust and ergonomic, light weight, orbit of only 3 mm, with air inlet female threaded 1/4 "gas, cruise control and exhaust air silencer.
- Non-slip rubber coated handle and anti-cold for the operator's hands.
- Provided with air connection inserted series japan and pad  $\varnothing$  75 mm.

Code	Desc.
4180008120	5715

Spare Parts				
Code	Description	Diam. mm	Features	Grain
3420102230	75-M6	-	Velcro backing pad diameter 75mm M6	-
3340500050	75X120	75	Velcro abrasive disks	120
3340500060	75X150	75	Velcro abrasive disks	150
3340500070	75X180	75	Velcro abrasive disks	180
3340500080	75X220	75	Velcro abrasive disks	220
3340500100	75X280	75	Velcro abrasive disks	280
3340500110	75X320	75	Velcro abrasive disks	320
3340500130	75X400	75	Velcro abrasive disks	400
3340500160	75X800	75	Velcro abrasive disks	800
3340500190	75X1500	75	Velcro abrasive disks	1500
3340500250	75X2500	75	Velcro abrasive disks	2500
3420102200	74	-	Interface soft velcro 75mm	-

9

DATI TECNICI														
Att. Fjl	Platorello	Orbita	RPM	Peso	$\varnothing$ Int. Tube Consigliato	Max. Pressione	Consumo Aria	LWA	LpA	Vibrazioni				
Inch	$\varnothing$ -Filetto	mm	Min <sup>-1</sup>	Kg	mm	Bar	L/Min	db (A)	db (A)	m/s <sup>2</sup>				
1/4 IG	70-6MA	3	10000	1.10	8	6,3	<table border="1"> <tr> <td>Min</td> <td>Max</td> </tr> <tr> <td>380</td> <td>430</td> </tr> </table>	Min	Max	380	430	-	80	<2,5
Min	Max													
380	430													



## Mini angle polisher 75 mm



- Mini angle polisher latest generation, specially designed for use with pads or discs of maximum diameter 75 mm. Ideal for polishing of small parts and in confined spaces, where are required high quality finishes.
- Used successfully in the areas of the body, metal working and wood. Particularly suitable in combination with our repair kits headlights code 411 00 18010-4645.
- Robust and ergonomic, light weight, equipped with air inlet female threaded 1/4 "gas, cruise control and exhaust air silencer.
- Non-slip rubber coated handle and anti-cold for the operator's hands.
- Provided with air connection inserted series japan and pad 75 mm.

Code	Desc.
4180008130	5720

Spare Parts				
Code	Color	Density	Description	Features
3420102240	-	-	76-5/46	Velcro backing pad diameter 75 mm 5/16 "UNF
3420102210	Arancio	Hard	75/D	Dented buffers
3420102220	Light blue	Soft	75/M	Dented buffers

DATI TECNICI														
Alt. Fil	Platello	Orbita	RPM	Peso	Ø Int. Tubo Consigliato	Max. Pressione	Consumo Aria	LWA	LpA	Vibrazioni				
Inch	Ø-Filetto	mm	Min <sup>-1</sup>	Kg	mm	Bar	L/Min	db (A)	db (A)	m/s <sup>2</sup>				
1/4 IG	70-5/16	-	2800	1,10	8	6,3	<table border="1"> <tr> <td>Min</td> <td>Max</td> </tr> <tr> <td>380</td> <td>430</td> </tr> </table>	Min	Max	380	430	-	80	<2,5
Min	Max													
380	430													

## Mini miter angle 75 mm



- Small, handy machine for cutting pipes, laminates, wire ropes, etc..
- Suitable for all sectors of metal working: bodywork, mechanical car / trucks, carpentry, maintenance, engineering, etc..
- Suitable for use with abrasive disks of 75 mm diameter, with a center hole of 10mm.
- The handle and the protective cover designed for working in any position.
- Machine body in metal coated with a special anti-skid paint, rear exhaust.
- Supplied as standard with Japan series air connection cod. 3450005600-1 / 4M

Code	Desc.
4180006400	5688

Spare Parts		
Article	Code	Description
Cutting discs	3400001000	75x1,2
Cutting discs	3400002600	75x3,2
Grinding Discs	3400001400	75x6,4



DATI TECNICI											
Att. Fil.	Albero	Potenza	RPM	Peso	Ø Int. Tubo Consigliato	Max. Pressione	Consumo Aria	LWA	LpA	Vibrazioni	
			N <sub>o</sub>								
Inch	Disc	Watt	Min <sup>-1</sup>	Kg	mm	Bar	L/Min	db (A)	db (A)	m/s <sup>2</sup>	
1/4	70X10	350	20000	0,8	8	6,3	Min 580	Max 620	105,2	93,2	<2,5

## Pneumatic saw



- Ideal for body shop and sheet metal processing workshops.
- With an insulated handle.
- Private non-slip material.
- Supplied as standard with Japan series air connection cod. 3450005600-1 / 4M

Code	Desc.
4180005600	5673

Spare Parts		
Code	Description	Teeth per inch
3220000600	39T18	18
3220000610	39T24	24
3220000620	39T32	32



**UTENSILE AD ALTA PRESTAZIONE DI TAGLIO  
TAGLIO PULITO NEGLI SPIGOLI**

DATI TECNICI											
Att. Fil.	Denti	Corsa	Corse	Peso	Ø Int. Tubo Consigliato	Max. Pressione	Consumo Aria	LWA	LpA	Vibrazioni	
Inch	Z=	mm	Min <sup>-1</sup>	Kg	mm	Bar	L/Min	db (A)	db (A)	m/s <sup>2</sup>	
1/4	14/24/32	10	9500	0,65	8	6,3	Min -	Max 220	95	82	27,2



## Pneumatic chipping hammer kit



- Chipping hammer ideal for jobs in construction and plumbing.
- Suitable for cutting sheet metal cutting and detachment rivets and rivets, removal of coatings and plasters.
- Kit in shockproof case.
- Chisels with 11 mm hex.
- Content: 1 hammer - 1 retaining spring and No. 5 chisels for metal and sheet metal.
- Supplied as standard with Japan series air connection cod. 3450005600-1 / 4M

Code	Desc.	Characteristics
4180004800	566	Kit complete chipping hammer

Spare Parts		
Code	Description	Features
4180004860	5664/1	Curved chisel for cutting sheet metal maximum thickness 1mm (1)
4180004880	5664/2	Chisel cutting by welding spots (2)
4180004900	5664/3	Rovetti curved chisel size (3)
4180004920	5664/4	Chisel universal (4)
4180004940	5664/5	Chisel double edged sheet metal (5)
4180002800	5641	Check spring (6)
4180004850	5663	Quick change chuck (7)

N.B.: l'accessorio mandrino cambio rapido sostituisce la molla e permette la sostituzione degli scalpelli in tempi rapidissimi.

DATI TECNICI										
Att. Fil.	Inserto Scalp.	Corsa	Colpi	Peso	Ø Int. Tubo Consigliato	Max. Pressione	Consumo Aria	LWA	LpA	Vibrazioni
Inch	Inch/mm	mm	Min <sup>1</sup>	Kg	mm	Bar	L/Min	db (A)	db (A)	m/s <sup>2</sup>
1/4	Ø 0,401 Ø 10,2	60	3000	1,50	8	6,3	Min Max	105,3	92,3	8,9

## Detach points with pneumatic torque arm



- Maximum convenience for the removal of the welding points.
- With special arm which holds the workpiece in place for the precise removal, no reaction of the welding point.
- By adjusting the drilling depth.
- Equipped with HSS drill diameter 8 mm length. 44 mm.
- Supplied as standard with Japan series air connection cod. 3450005600-1 / 4M

Code	Desc.
4180005700	5675

Spare Parts					
Code	Description	Dim. connection	Tip type	Total length	Use for
4770000250	25 - 6,5	8	HSS COBALT	40	Normal steels limited thickness
4770000260	26 - 8	8	HSS COBALT	40	Normal steels limited thickness
4770000262	26 - 44/8	8	HSS COBALT	44	Normal steels limited thickness
4770004870	346 - 6,5	8	HSS COBALT + TITANIUM	44	Cutting steels of low and medium hardness
4770004880	346 - 8	8	HSS COBALT + TITANIUM ALUMINIUM	44	Cutting steels of low and medium hardness
4770004890	347 - 40	8	INTEGRAL HARD METAL	40	Drilling spars
4770004900	347 - 4	8	INTEGRAL HARD METAL	44	Drilling spars

DATI TECNICI									
Att. Fil.	Utensile	RPM	Peso	Ø Int. Tubo Consigliato	Max. Pressione	Consumo Aria	LWA	LpA	Vibrazioni
Inch	mm	Min <sup>1</sup>	Kg	mm	Bar	L/Min	db (A)	db (A)	m/s <sup>2</sup>
1/4	Ø 8	1800	1,6	8	6,3	Min Max	700	74,1	<2,5

## Pneumatic Knife detach glass



- Detach glass swinging.
- Tool for the removal of glued glazing.
- Cutting with oscillating blades.
- Supplied without blade.
- Tool with feeding tube length about 140cm and protective cover exhaust air.
- Supplied as standard with Japan series air connection cod. 3450005600-1 / 4M

Code	Desc.
4180005800	5677



DATI TECNICI											
Att. Fil	Albero	Lama	RPM	Peso	Ø Int. Tubo Consigliato	Max. Pressione	Consumo Aria	LWA	LpA	Vibrazioni	
Inch	mm	mm	Min <sup>-1</sup>	Kg	mm	Bar	L/Min	db (A)	db (A)	m/s <sup>2</sup>	
1/4	6 - punte 19,8	12 - punte 22	20000	1,0	8	6,3	Min 370	Max 530	92,8	79,8	4,3

## Straight knife blade to detaches glass



- Steel blade knife detaches the glass, with universal double hexagon, for the separation of the windscreen and glued.
- Available in various shapes and sizes for the most common applications.

Code	Desc.	Extr. mm
4180006020	5679/G35-25	25/35

## Straight knife blade to detaches glass



- Steel blade knife detaches the glass, with universal double hexagon, for the separation of the windscreen and glued.
- Available in various shapes and sizes for the most common applications.

Code	Desc.	Extr. mm
4180006045	5679/G100-60	50/90

## Circular blade with hexagon for knife detaches glass



- Steel blades for knives detaches the glass, with universal double hexagon, for the separation of the windscreen and glued.
- Available in various shapes and sizes for the most common applications.

Code	Desc.	Ø mm
4180005900	5678/S80	80

## Blade at U 24 mm glass detach knife



- Steel blade knife staccavetro, with universal double hexagon, for the separation of the windscreen and glued.
- Available in various shapes and sizes for the most common applications.

Code	Desc.	Extr. mm
4180006000	5679/U24	24

## Blade at U 36 mm glass detach knife



- Steel blade knife detaches the glass, with universal double hexagon, for the separation of the windscreen and glued.
- Available in various shapes and sizes for the most common applications.

Code	Desc.	Extr. mm
4180006010	5679/U36	36

## blade at U 65 mm glass detach knife



- Steel blade knife detaches the glass, with universal double hexagon, for the separation of the windscreen and glued.
- Available in various shapes and sizes for the most common applications.

Code	Desc.	Extr. mm
4180006050	5880	60

## Blade offset, knife detaches glass



- Steel blade knife detaches the glass, with universal double hexagon, for the separation of the windscreen and glued.
- Available in various shapes and sizes for the most common applications.

Code	Desc.	Extr. mm
4180006040	5679/G57-35	35

## Angled blade knife detaches glass



- Steel blade knife detaches the glass, with universal double hexagon, for the separation of the windscreen and glued.
- Available in various shapes and sizes for the most common applications.

Code	Desc.	Extr. mm
4180006030	5679/H39-24	25,4-90°

## Blades hammer



- Steel blade knife detaches the glass, with universal double hexagon, for the separation of the windscreen and glued.
- Available in various shapes and sizes for the most common applications.

Code	Desc.
4180006055	5681

## Lama a L per coltello staccavetri



- Lama in acciaio per coltelli staccavetro, con attacco universale a doppio esagono, per il distacco di parabrezza e cristalli incollati.

Code	Desc.	L. tagliente mm
4180006070	FB-209	38-90°

## Lama dritta per coltello staccavetri



- Lama in acciaio per coltelli staccavetro, con attacco universale a doppio esagono, per il distacco di parabrezza e cristalli incollati.
- Con tagliente zigrinato

Code	Desc.	L. tagliente mm
4180006060	FB-081	60

## Lama dritta per coltello staccavetri



- Lama in acciaio per coltelli staccavetro, con attacco universale a doppio esagono, per il distacco di parabrezza e cristalli incollati.

Code	Desc.	L. tagliente mm
4180006065	FB-194	110

## Pneumatic rode-valves



- The rode-valves is essential in all the workshops of car repairs for the speed with which it allows to perform polishing of valves. This device makes automatic and therefore perfectly homogenous traditional technique of polishing abrasive, is the means for alternating rotations to the right and left side. Supplied in plastic case with full accessories.
- Contents: 1 sucker  $\varnothing$  20; 1 cup  $\varnothing$  33; 1 cup  $\varnothing$  38; 1 O 1 revolves reduction  $\varnothing$   $\varnothing$  9 reduction on July 1; 1 torque screwdriver for valves with intaglio.

Code	Desc.
4180001400	5627

Spare Parts		
Code	Description	Features
4180001500	5628	VACUUM SMALL $\varnothing$ 20
4180001600	5629	VACUUM AVERAGE $\varnothing$ 33
4180001700	5630	VACUUM HIGH $\varnothing$ 38
4180001800	5631	ARTICULATED JOINT

## Universal pneumatic disassemble Valves



- Universal pneumatic device for disassembly / assembly of all types of valves in petrol and diesel engines.
- Built specifically for 4/5 valves per cylinder engines.
- The new version of the valve-awards extractors allows greater convenience and a smaller footprint.
- Operating pressure: 6 bar.
- Max. thrust of the pneumatic piston: 6 bar 75 kg.
- Max. overall dimensions: width 42 cm, height 22 cm.

Code	Desc.
4430049600	952

Spare Parts	
Code	Description
4430054160	1107 - ESTRATTORE DIAM. 25,5 CON BOCCOLE:24,5-25-27-29-32 MM
4430054170	1108 - ESTRATTORE DIAM 34 CON BOCCOLE: 34-41-50 MM
4430054180	1109 - ESTRATTORE VALVOLE DIAM. 19,8MM



SCEGLIERE E MONTARE SUL S.M.V. IL COLLARE SPINGI MOLLA (ESTRATTORE) ADEGUATO ALLA VALVOLA DELLA TESTATA SU CUI SI DEVE INTERVENIRE (VEDI FIG. 1 POS. 1). ALLENTARE LA VITE (VEDI FIG. 1 POS. 2) CHE BLOCCA IL CILINDRO (VEDI FIG. 2 POS. 3) SUL BRACCIO (VEDI FIG. 1 POS. 4) AZIONARE IL COMANDO PNEUMATICO (VEDI FIG. 1 POS. 5). IL CILINDRO SCORRERÀ A BASSISSIMA VELOCITÀ NEL SUO ALLOGGIAMENTO FINO A RAGGIUNGERE IL FINE CORSA. CON QUESTA OPERAZIONE ABBIAMO RILEVATO L'ALTEZZA DELLA VALVOLA. CHIUDERE IL COMANDO PNEUMATICO (VEDI FIG. 1 POS. 5) AVANZARE IL CILINDRO PNEUMATICO (VEDI FIG. 1 POS. 3) DI UN SEGNO (CORRISPONDE A 1 cm). SE LA MOLLA E' DOPPIA AVANZARE DI 2 SEGNI. SERRARE LA VITE DI BLOCCAGGIO (VEDI FIG. 1 POS. 2), AZIONARE NUOVAMENTE IL COMANDO PNEUMATICO PER OTTENERE LA COMPRESSIONE DELLA MOLLA VALVOLA CHE CONSENTE L'ESTRAZIONE DEI CONI (VEDI FIG. 2). NEL CASO IN CUI I CONI RIMANGANO BLOCCATI, DARE QUALCHE COLPO DI MAZZUOLO (DI LEGNO O DI PLASTICA, VEDI FIG. 3). PER EFFETTUARE IL RIMONTAGGIO ESEGUIRE IN MODO INVERSO LE OPERAZIONE EFFETTUATE (VEDI FIG. 3).

**PRONTO PER ESSERE UTILIZZATO!**

**UTILIZZO**

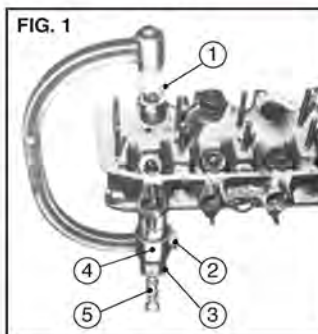

**Disassembles pneumatic shock absorbers**



Massima semplicità ed affidabilità

- Disassembles pneumatic dampers.
- Extremely versatile thanks to the self-leveling beam that fits perfectly in any spring shock absorbers conical or decentralized (see good, stylus, Alpha 147).
- For all cushions with Mac Pherson system.
- The particular composition of the cylinder, built in light aluminum, nylon resin and fiberglass prevents corrosion and oxidation of the internal parts of the machine.
- Equipped with protective cage that allows you to work freely and safely (also adaptable on the previous model).
- Supplied with two brackets for springs with a diameter of 78 to 130 mm and from 125 to 205 mm for a very wide range of use, and a locking clamp our code 4430049870.
- And 'particularly suitable for disassembly / reassembly of the dampers of type long, in vehicles comm.li, off-road, minivans and SUVs.
- This tool provides a high saving of time and a total security during all stages, thanks to the safety valves of the pneumatic system and the reliability of the parts that compose it.
- Convenient tray gear on the upper part of the machine.
- With CE certification.
- With operating instructions and maintenance.
- TECHNICAL DATA
- Pressure: min. 6 Atm; max 10 Atm.
- Overall dimensions: 140x65x40 cm.
- Weight: 62 kg.
- Max thrust: 6 Atm: 735 kg; 8 Atm: 980 kg; 10 ATM: 1250 kg.

Code	Desc.
4430049855	970-002

**Locking clamp for shock absorbers**



- Vice applicable to disassemble-pneumatic shock absorbers our art. 443 00 49855-970-002.
- The grip allows you to insert the shock absorbers to the tool when for reasons dimensional structural or not and 'can use one of two brackets supplied.
- The grip allows you to use it apart dampers for models mounted on cars alfa (see 156) that have small springs (not system MacPherson).

Code	Desc.
4430049870	971



## Adapters for springs tight coil



- Couple adapters with coil springs tight, for mounting on our dismounts pneumatic dampers cod. 443 00 49855-970-002.
- This pair of adapters allows the dismantling, in union with the chuck cod. 443 00 49870-971, also of the springs with very narrow coils mounted on some cars, where the jaws supplied as standard are not effective.
- Indicate on car with multi-link front suspension.
- Alfa 156.

Code	Desc.
4430049860	971A

## Bracket kit for shock absorbers Mercedes, Renault and Citroen



- Kit consists of three brackets applicable in many car models: Mercedes Class A, B, C, E, Renault Megane, Citroen C2, C3.
- Kit adaptable to our shock absorbers dismantled tire code 4430049855 (also the previous model).
- Consisting of: 1) Bracket take springs with diameters from 105 to 182 mm, adaptable to the Mercedes Class A, B, C, E, Renault Megane and Citroen C2, C3. 2) upper bracket for shock absorbers Mercedes Class A, B, C, E; 3) bracket galvanized white-specific shocks Mercedes E-Class.

Code	Desc.
4430049875	971C

CAMPO DI UTILIZZO	TIPOLOGIE DI STAFFE
MERCEDES CLASSE A,B,C	1- STAFFA PRENDI MOLLE CON DIAMETRO DA 105 A 182 MM 2- STAFFA SUPERIORE PER CLASSE A, B, C, E
MERCEDES CLASSE E	1- STAFFA PRENDI MOLLE CON DIAMETRO DA 105 A 182 MM 2- STAFFA SUPERIORE PER CLASSE A, B, C, E 3- STAFFA ZINCATA BIANCA SPECIFICA CLASSE E
RENAULT MEGANE, CITROEN C2, C3	1- STAFFA PRENDI MOLLE CON DIAMETRO DA 105 A 182 MM

## Staffa media



- Utilizzabile su smonta ammortizzatori sino a 2,5 Ton di potenza.
- Per ultime vetture del gruppo Fiat
- Range 105-182 mm
- Staffa non in dotazione dello smonta ammortizzatori

Code	Desc.	Range
4430049876	971F	105-182 Nm

## Screwdriver screwer 1/4 "3.6V-1.5Ah



- Practical screwdriver folding stylus with hexagonal 1/4 "for the direct use of bits of the same size. Lightweight, small and handy for assembly and dismantling, even in tight spaces.
- Can be used by anyone who needs to assemble or disassemble M6 screws with a maximum diameter in the fields: mechanical, bodywork, furniture makers, fitters and maintenance workers, electricians, builders, plumbers, etc.
- Equipped with double removable battery 3.6 Volts 1.5 Ah Li-Ion, 21 positions selectable clutch, handle covered in rubber anti-oil, non-slip, useful in an upright position and folded gun, LED light for illumination working point, last block of the gears for hand tightening.
- Standard equipment: double lithium battery, rapid charger for 30 minutes and carrying case. Dimensions: 46 X 276 X 134 mm. Weight: 0.5 Kg.

9

Code	Desc.
4170020000	EY7410-LA2S

Spare Parts		
Article	Code	Desc.
Li-Ion to put 3.6V-1.5Ah	417RC15000	EY9L10B
Quick charger	417RC15010	EY0L10B

Technical Features	
Peso (batterie incluse)	0,5 Kg
Dimensions (Ø x L straight X H at an angle)	46 X 276 X 134 mm
Clutch position torque	ca. 0,1 Nm
Posizioni della frizione	21
Clutch torque	2,9 Nm
Maximum torque (Nm)	4,4 Nm
Velocità a vuoto (min/max)	200/600 rpm
Tempo di ricarica (utilizzabile/100%)	15/30 minutes
Volts	3,6 Volts
Battery capacity	1,5 Ah (Li-Ion)

## Cordless drill 10.8V - 1.5Ah Li-Ion



- Cordless drill small, light and compact, easy to handle and great power. Powered with high-capacity batteries Li-Ion and has electronic protections against overload and overheating.
- Suitable for use in the areas of plant, maintenance, electrical and plumbing and heating, light carpentry and joinery, bodywork and machine shops in general.
- It equipped with adjustment of the tightening torque of 17 positions plus a fixed position for drilling, illumination of the working point, the battery charge indicator, double mechanical speed and speed regulation electronics with the start button. Reversible.
- Body in shock resistant material, covered with non-slip material, chuck capacity from 1 to 10 mm.
- Standard equipment: double battery Li-Ion 10.8 volts 1.5 Ah, rapid charger, carrying case Cordura resistant to transport and storage.

Code	Desc.
4170020250	EY7430-LA2S

Spare Parts		
Article	Code	Desc.
Lithium battery 10.8V - 1.5Ah	417RC15150	EY9L32
Quick charger	417RC15155	EY0L32
Chuck 1-10 mm 1/2 "X20UNF	417RC00080	02/01/10

Technical Features	
Diametro massimo foratura nel legno	18 mm
Diametro massimo foratura nell'acciaio	10 mm
Diametro massimo viti a ferro	M5
Maximum torque (2nd speed)	15 Nm
Maximum torque (1st speed)	30 Nm
Weight including batteries (kg)	1,0 Kg
Length x height dimensions	209 X 190 mm
Spindle capacity (mm)	1-10 mm
Tensione e capacità batteria	10,8 V - 1,5 Ah
Velocità massima in prima/seconda velocità	110-400 / 320-1300 rpm
Diametro massimo viti a legno	4,2 mm

## Cordless drill 14,4V-2,0Ah



- Compatto e potente trapano avvitatore reversibile dotato di pacchi batteria agli Ioni di Litio con capacità di 2,0 Ah. Grande potenza di avvitatura, lunga durata della carica, ottimo bilanciamento e leggerezza dell'utensile ne fanno lo strumento ideale per ogni tipo di lavoro.
- Indicato per applicazioni nei settori: meccanico, autocarrozzeria, mobiliari, montatori e manutentori, elettricisti, quadristi, idraulici, carpenteria metallica e in legno, costruzione e posa infissi, ecc.
- Dotato di doppia batteria da 14,4Volts 2,0 Ah agli Ioni di Litio, 18 posizioni di frizione regolabili e posizione fissa per foratura, mandrino autoserrante di capacità max 13 mm, regolazione elettronica di velocità e doppia posizione di velocità meccanica, freno elettronico al rilascio del pulsante, impugnatura rivestita antiscivolo ed antiolio, led per illuminazione del punto di lavoro, clip per aggancio a cintura.
- Dotazione di serie: doppia batteria al Litio, caricabatteria rapido, valigetta per trasporto. Dimensioni: 60 X 193 X 218 mm. Peso: 1,65 Kg.

Code	Desc.
4170020280	EY7441-LF2S

Spare Parts			
Article	Code	Desc.	
Li-Ion 14,4V-2,0Ah	417RC15180	EY9L47	
Li-Ion 14,4V-2,0Ah	417RC15030	EY0L82B	
Spindle 1.5 to 13 1 / 2X20 "UNF	417RC15040	1100	

Tecnical Features	
Volts	14,4 Volts
Weight including batteries (kg)	1,65 Kg
Dimensions	60 X 193 X 218 mm
Diametro massimo di foratura con fresa (metallo)	33
Maximum hole diameter (wood / metal)	35/13
Posizioni della frizione	18 + Fixed
Maximum torque (Nm)	41,5 Nm
Velocità a vuoto (min/max) II° velocità	200/1400 rpm
Velocità a vuoto (min/max) I° velocità	70/400 rpm
Tempo di ricarica (utilizzabile/100%)	30/35 minutes
Battery capacity	2,0 Ah (Li-Ion)



## Cordless drill 14,4V-4,2Ah



- Compatto e potente trapano avvitatore reversibile dotato dei nuovissimi pacchi batteria agli Ioni di Litio con capacità di 4,2 Ah. Grande potenza di avvitatura, lunga durata della carica, ottimo bilanciamento e leggerezza dell'utensile ne fanno lo strumento ideale per ogni tipo di lavoro.
- Indicato per applicazioni nei settori: meccanico, autocarrozzeria, mobiliari, montatori e manutentori, elettricisti, quadristi, idraulici, carpenteria metallica e in legno, costruzione e posa infissi, ecc.
- Dotato di doppia batteria da 14,4Volts 4,2 Ah agli Ioni di Litio, 18 posizioni di frizione regolabili e posizione fissa per foratura, mandrino autoserrante di capacità max 13 mm, regolazione elettronica di velocità e doppia posizione di velocità meccanica, freno elettronico al rilascio del pulsante, impugnatura rivestita antiscivolo ed antiolio, led per illuminazione del punto di lavoro, clip per aggancio a cintura.
- Dotazione di serie: doppia batteria al Litio, caricabatteria rapido, valigetta per trasporto. Dimensioni: 60 X 193 X 232 mm. Peso: 1,75 Kg.

Code	Desc.
4170020300	EY7441-LS2S

Spare Parts			
Article	Code	Desc.	
Li-Ion 14,4V-4,2Ah	417RC15020	EY9L45B	
quick Charger	417RC15030	EY0L82B	
Spindle 1.5 to 13 1 / 2X20 "UNF	417RC15040	1100	

Tecnical Features	
Weight including batteries (kg)	1,75 Kg
Dimensions	60 X 193 X 232 mm
Diametro massimo di foratura con fresa (metallo)	33
Maximum hole diameter (wood / metal)	35/13
Posizioni della frizione	18 + Fixed
Maximum torque (Nm)	41,5 Nm
Velocità a vuoto (min/max) II° velocità	200/1400 rpm
Velocità a vuoto (min/max) I° velocità	70/400 rpm
Tempo di ricarica (utilizzabile/100%)	50/60 minutes
Volts	14,4 Volts
Battery capacity	4,2 Ah (Li-Ion)

## Cordless drill 14.4 V-4.2 Ah Automatic with



**CAMBIO AUTOMATICO  
DI VELOCITÀ E COPPIA**

- Compact and powerful cordless drill reversible equipped with brand new lithium-ion battery packs with a capacity of 4.2 Ah. Great power tightening, long term of office, good balance and light weight make it the ideal tool for every job.
- Suitable for applications in: mechanical, bodywork, furniture makers, fitters and maintenance workers, electricians, builders, plumbers, metal and wood carpentry, construction and installation fixtures, etc.
- Equipped with double battery 14,4Volts 4.2 Ah Li-Ion, 18 positions adjustable clutch and fixed position for drilling, chuck capacity max 13 mm, electronic control of speed and double speed position mechanical, electronic brake to button is released, handle covered slip and oil resistant, LED lighting for the working point, clip belt holder.
- Standard equipment: double lithium battery, quick charger, carrying case. Dimensions: 62 X 199 X 254 mm. Weight: 1.85 kg.

Code	Desc.
4170020010	EY7443-LS2S

Spare Parts		
Article	Code	Desc.
Li-Ion 14,4V-4,2Ah	417RC15020	EY9L45B
Quick Charger	417RC15030	EY0L82B
Spindle 1,5-13 1/2X20" UNF	417RC15040	1100

Tecnical Features	
Peso (batterie incluse)	1,85 Kg
Dimensions	62 X 199 X 254 mm
Maximum hole diameter (wood / metal)	33
Diametro massimo di foratura con fresa (metallo)	35/13
Posizioni della frizione	18 + Fixed
Maximum torque (Nm)	41,5 Nm
Velocità a vuoto (min/max) II° velocità	160/1400 rpm
Volts	14,4 Volts
Battery capacity	4,2 Ah (Li-Ion)
Velocità a vuoto (min/max) I° velocità	60/400 rpm
Tempo di ricarica (utilizzabile/100%)	50/60 minutes

# Drill Driver 18V- 3,0 Ah



CE

- Drill reversible screwdriver powerful features of the newest battery packs Li-Ion with capacity of 3.0 Ah. Great power tightening, long term of office, good tool balance and lightness make it the ideal tool for every job.
- Suitable for applications in the fields of mechanical, bodywork, furniture makers, fitters and maintenance workers, electricians, builders, plumbers, metal carpentry and wood, construction and installation fixtures, etc.
- New ultra-compact and powerful brushless motor, which thanks to the new shell shock resistant "carbon look" reduces the size and weight of the machine, improves its balance and allows him to work in tight spaces.
- 18-volt battery and has dual 3.0 Ah Li-Ion, 18 clutch positions adjustable and fixed position for simple drilling, keyless chuck capacity of max 13 mm, electronic adjustment of speed and double position mechanical speed, electronic brake the button is released, coated non-slip grip and oil-resistant, LED lighting of the working point, clip belt holder.
- Standard equipment: double lithium battery, super charger, carrying case.

Code	Desc.
4170020480	EY74A2-PN2G

Spare Parts		
Article	Code	Desc.
Lithium battery 18V-5,0Ah	417RC15300	EY9L53B
Lithium battery 18V-3,0Ah	417RC15050	EY9L50B
rapid charger	417RC15030	EY0I82B
Spindle 1-13 - 1/2"X20UNF	417RC00110	3/1,5-13

Technical Features	
Tempo di ricarica (utilizzabile/100%)	45/60 minutes
Battery capacity	18V-3,0Ah
Maximum torque (Nm)	50 Nm
Posizioni della frizione	18+fixed
Velocità a vuoto (min/max) II° velocità	70-1580 rpm
Velocità a vuoto (min/max) I° velocità	20-480 rpm
Dimension mm	68X178X234
Ø max hole in the metal with cutter (mm)	33
Peso (batterie incluse)	1,8 Kg
Ø max hole in wood (mm)	38
Ø foro max metallo (mm)	13

## Cordless drill 18 V-5,0 Ah Li-Ion



- Potente trapano avvitatore reversibile dotato dei nuovissimi pacchi batteria agli Ioni di Litio con capacità di 5,0 Ah. Grande potenza di avvitatura, lunga durata della carica, ottimo bilanciamento e leggerezza dell'utensile ne fanno lo strumento ideale per ogni tipo di lavoro.
- Indicato per applicazioni nei settori: meccanico, autocarrozzeria, mobiliari, montatori e manutentori, elettricisti, quadristi, idraulici, carpenteria metallica e in legno, costruzione e posa infissi, ecc.
- Nuovo e potente motore brushless compattissimo, che grazie anche alla nuova scocca in materiale antiurto "carbon look" riduce le dimensioni ed il peso della macchina, migliora il suo bilanciamento e gli permette di poter lavorare negli spazi più angusti.
- Dotato di doppia batteria da 18 Volts 5,0 Ah agli Ioni di Litio, 18 posizioni di frizione regolabili e posizione fissa per foratura semplice, mandrino autoserrante di capacità max 13 mm, regolazione elettronica di velocità e doppia posizione di velocità meccanica, freno elettronico al rilascio del pulsante, impugnatura rivestita antiscivolo ed antiolio, led per illuminazione del punto di lavoro, clip per aggancio a cintura.
- Dotazione di serie: doppia batteria al Litio, caricabatteria rapido, valigetta per trasporto. Dimensioni: 75 X 250 X 180

Code	Desc.
4170020330	EY74A2-LJ2G

Spare Parts		
Article	Code	Desc.
Batteria al litio 18 V - 5,0 Ah	417RC15300	EY9L53B32
Caricabatterie rapido	417RC15030	EY0L82B
Mandrino 1-13 - 1/2"X20 UNF	417RC00110	3/1,5-13

Technical Features	
Peso (batterie incluse)	2,0 Kg
Ø max hole in wood (mm)	36 mm
Ø foro max metallo (mm)	13 mm
Ø max hole in masonry (mm)	13 mm
Dimension mm	75 X 250 X 180 mm
Velocità a vuoto (min/max) I° velocità	20-480 giri/minuto
Posizioni della frizione	18 + fisso + percussione
Maximum torque (Nm)	50 Nm
Velocità a vuoto (min/max) II° velocità	70-1580 giri/minuto
Tempo di ricarica (utilizzabile/100%)	65/80 minuti
Battery capacity	5,0 Ah
Volts	18,0



## Cordless drill percussion 18V- 3,0 Ah

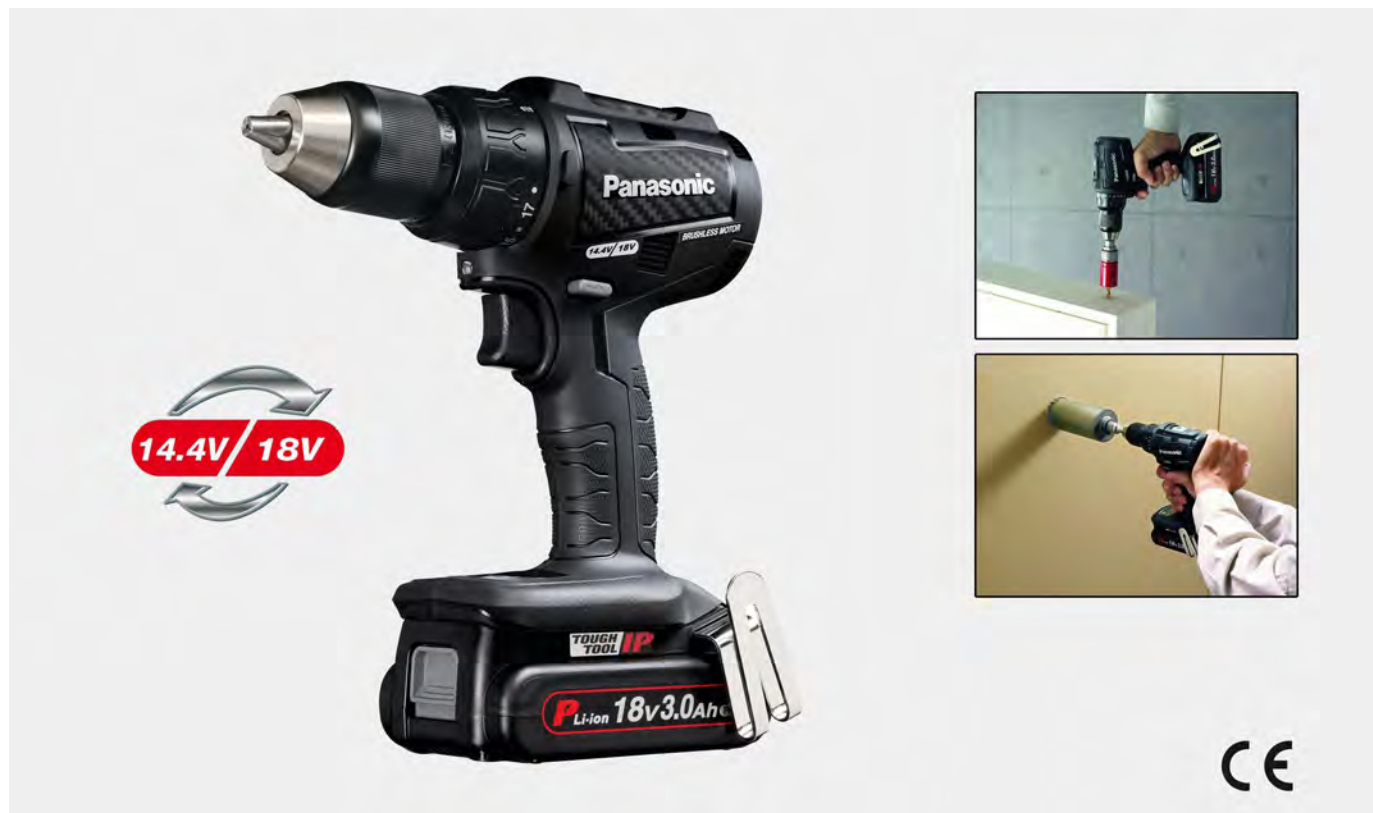

- Reversible drill driver with powerful mechanical hammer equipped with the latest lithium-ion battery packs with capacity of 3.0 Ah. Great power tightening, long term of office, good tool balance and lightness make it the ideal tool for every job.
- Suitable for applications in the fields of mechanical, bodywork, furniture makers, fitters and maintenance workers, electricians, builders, plumbers, metal carpentry and wood, construction and installation fixtures, etc.
- New ultra-compact and powerful brushless motor, which thanks to the new shell shock resistant "carbon look" reduces the size and weight of the machine, improves its balance and allows him to work in tight spaces.
- Equipped with dual 18-volt battery and 3.0 Ah Li-Ion, 18 clutch positions adjustable and fixed position for simple and swing drill, keyless chuck capacity of up to 13 mm, electronic adjustment of speed and double mechanical speed position, electronic brake the button is released, coated non-slip grip and oil-resistant, LED lighting of the working point, clip belt holder.
- Standard equipment: double lithium battery, super charger, carrying case.

Code	Desc.
4170020500	EY79A2-PN2G

Spare Parts		
Article	Code	Desc.
Battery Lithium 18V-5,0Ah	417RC15300	EY9L53B
Battery Lithium 18V-3,0Ah	417RC15050	EY9L50B
Rapid charger	417RC15030	EY0I82B
Chuck 1-13 - 1/2 "x20UNF	417RC00110	3/1,5-13

Technical Features	
Battery capacity	18V-3,0Ah
Tempo di ricarica (utilizzabile/100%)	45/60 minutes
Maximum torque (Nm)	50 Nm
Number percussions per minute speed 1	540-8500
Posizioni della frizione	18+fixed+percussion
Number percussions per minute speed 2	1260-28400
Velocità a vuoto (min/max) II° velocità	70-1580
Velocità a vuoto (min/max) I° velocità	30-470
Ø max hole in masonry (mm)	13
Dimension mm	68x188x234
Ø max hole in the metal with cutter (mm)	33
Ø foro max metallo (mm)	13
Ø max hole in wood (mm)	36
Peso (batterie incluse)	1,85 Kg

## Cordless Hammer drill 18 V-5,0 Ah



- Powerful reversible drill driver with mechanical hammer, equipped with the latest lithium-ion battery packs with 5.0 Ah capacity. Great power tightening, long term of office, good tool balance and lightness make it the ideal tool for every job.
- Suitable for applications in: mechanical, bodywork, furniture makers, fitters and maintenance workers, electricians, builders, plumbers, metal carpentry and wood, construction and installation fixtures, etc.
- New and powerful brushless motor very compact, which thanks to the new shell shock resistant "carbon look" reduces the size and weight of the machine, improves its balance and allows him to work in tight spaces.
- It equipped with dual battery 18 Volts 5.0 Ah Li-Ion, 18 clutch positions adjustable and fixed positions for simple and hammer drilling, the keyless chuck capacity max 13 mm, electronic adjustment of speed and double mechanical speed position, brake electronic release the button, coated non-slip grip and oil-resistant, LED lighting of the working point, clip belt holder.
- Standard equipment: double lithium battery, quick charger, additional handle, carrying case. Dimensions: 75 X 250 X 180 mm. Weight: 2.0 Kg.

Code	Desc.
4170020320	EY79A2-LJ2G

Spare Parts		
Article	Code	Desc.
Batteria al litio 18 V - 5,0 Ah	417RC15300	EY9L53B32
Caricabatterie rapido	417RC15030	EY0L82B
Mandrino 1-13 - 1/2"X20 UNF	417RC00110	3/1,5-13

Technical Features	
Peso (batterie incluse)	2,0 Kg
Ø max hole in masonry (mm)	13 mm
Dimension mm	75 X 250 X 180 mm
Ø foro max metallo (mm)	13 mm
Maximum torque (Nm)	50 Nm
Posizioni della frizione	18 + fisso + percussione
Ø max hole in wood (mm)	36 mm
Velocità a vuoto (min/max) I° velocità	20-480 giri/minuto
Velocità a vuoto (min/max) II° velocità	70-1580 giri/minuto
Volts	18,0
Battery capacity	5,0 Ah
Tempo di ricarica (utilizzabile/100%)	65/80 minuti

## Cordless hammer mechanism 1/4 "- 18V-5,0Ah



- Innovative cordless hammer mechanism with Female hexagon attach of 1/4" for direct mounting of bits with throat or portabits of any type.
- Suitable for craft and industrial sectors if necessary a reliable and lightweight tool: carpenters, light carpentry, sheet metal workers, fitters of windows in general, electrical and plumbing installers, assembly of structures in general, etc.
- New and powerful ultra-compact brushless motor, which thanks to the new shell shock resistant "carbon look" reduces the size and weight of the machine, improves its balance and allows him to work in tight spaces, the speed and torque control of three positions (low / medium / high) to adapt to all possible working conditions. The internal electronics allows him to work with different voltage batteries, and 14.4 is 18 volts with no problem and no significant performance
- **NEW FEATURE "Self drilling screws"**: selecting this function allows the machine to automatically adjust the speed and torque to the different moments of installation of self-drilling screws. Fast at the beginning and low torque, low speed and high torque once you have the hole and started the thread.
- compact size and low weight, excellent stability thanks to the well-centered masses. High battery capacity of 5.0 Ah for long-lasting power, reversibility, electronic speed control via the power button.
- Wood screws 4,2X75 of pine: n° 700
- Self drilling screws 4X13: n° 980
- metric screws M12X25: n° 360
- Standard equipment: double lithium battery, super charger, carrying case.

Code	Desc.
4170020340	EY75A7LJ2G

Tecnical Features	
Peso (batterie incluse)	1,7
Dimension mm	66 X 118 X 242
Maximum torque (3rd speed)	160 Nm
Maximum torque (2nd speed)	120 Nm
Maximum torque (1st speed)	26 Nm
Numero impulsi al minuto (3° velocità)	0 - 3100
Numero impulsi al minuto (2° velocità)	0 - 2900
Numero impulsi al minuto (1° velocità)	0 - 1900
Velocità a vuoto (min/max) III° velocità	0 - 2500
Velocità a vuoto (min/max) I° velocità	0 - 950
Velocità a vuoto (min/max) II° velocità	0 - 1400
Volts	18,0
Battery capacity	5,0 Ah
Tempo di ricarica (utilizzabile/100%)	65/80 minuti

Spare Parts		
Article	Code	Desc.
Batteria al litio 18 V - 5,0 Ah	417RC15300	EY9L53B32
Caricabatterie rapido	417RC15030	EY0L82B

## Cordless impact mechanism 1/2" - 18V-5,0Ah – 205Nm



- Powerfull cordless impact mechanism with square drive by 1/2" and engine by 18 Volts fully isolated. Handle perfectly balanced gun, low weight and maximum torque of 205 Nm.
- Can be used successfully in many craft and industry sectors: auto mechanics and heavy vehicles, roadside assistance, tire, various repairs and maintenance, and assembly of heavy plant and structures, the sector of industrial maintenance, etc .
- Mass swing double compact and powerful hammer, high capacity of 5.0 Ah battery for long-lasting power, reversibility, electronic speed control via the power button. The internal electronics allows him to work with different voltage batteries, and 14.4 is 18 Volts without any problem and without noticeable performance degradation.
- Coated handle slip and oil resistant, LED Lighting of the workplace, clip belt holder.
- Wood screws 4.2 x 75 mm of pine: n° 600
- Wood screws 5,2 x 120 of pine: n° 150
- Self-tapping screws 4 x 13 polycarbonate 1.6 mm thick: n° 1000
- Metric screws M16 x 25: n° 1100
- Metric screws M14 x 25: n° 1300
- Standard equipment: double lithium battery, super charger, carrying case.

9

Code	Desc.
4170020460	EY75A2LJ2S

Tecnical Features	
Peso (batterie incluse)	2,7 Kg
Tempo di ricarica (utilizzabile/100%)	55/70 minutes
Velocità a vuoto (g/min)	0 - 1550 rpm
Numero impulsi al minuto	0 - 2400
Maximum torque	205 Nm
Max diameter vines tightened	M16
Dimension mm	77 X 214 X 252 mm
Volts	18 Volts
Battery capacity	5,0 Ah

Spare Parts		
Article	Code	Desc.
Battery Li-Ion 18V-5,0Ah	417RC15300	EY9L53B
Rapid charger	417RC15030	EY0L82B



## Impact wrench 1/2 "x 18 V 3.0 Ah Li-Ion - 550 Nm



- Cordless impact wrench with square drive for sockets 1/2 ", lithium-ion batteries from 18 volts and capacity of 3.0 ha. High torque of 550 Nm. Replaceable brushes outside.
- Usable by mechanical automotive, tire, maintenance and mounting heavy carpentry, means breakdown.
- The lightweight, compact, and balance make it a tool easy and comfortable to use, the dual battery allows continuous use. With a charge you can make about 250 operations Tightening with 21mm. Adjustable speed by pressing the start button. Reversible for screwing and unscrewing.
- Cast aluminum body, grip in shockproof material lightweight and durable with anti-slip insert, screw caps on the outside for rapid brush replacement.
- Supplied with: plastic case, dual lithium battery and quick charger for 1 hour.

Code	Desc.
4170016180	M2028/2

Tecnical Features	
Dimensions	257X80X273
Weight including batteries (kg)	2,94 Kg
Indicatori di carica sulla batteria	4 led
Recharge time	1 h with automatic switch-off
Voltaggio/capacità batteria	18,0 V/3,0 Ah Li-Ion
Max. speed rpm	1650
Numero di impatti al minuto max	2100
Max. tightening torque (Nm)	550 Nm – 400 ft-lb

Spare Parts			
Article	Code	Desc.	
Battery 18.0 Volts - 3,0Ah Li-Ion	417RC15180	1136	
Charger for Li-Ion	417RC15185	1137	
Metal ring for square drive 1/2 "	418RC00350	47	
Coppia spazzole	418RC05200	178A	
19.2V battery - 2.0 Ah Ni-Cd old model	417RC01740	BGS1620	
Charger for Ni-Cd old model	417RC01750	90C	

## Cordless rotary-percussive drill 18V-5,0Ah



- Practical, compact and versatile tool that combines the two functions of the rotary hammer and drill-screwdriver reversible battery. Equipped with the latest lithium-ion battery packs with 5.0 Ah capacity. Possibility of use with batteries of 18 and 14.4 Volts for maximum flexibility of use. T-handle for better balance, quick attack tools SDS-Plus type with bits serial port adapter.
- Utensil indicated for all types of machining operations especially in the area of maintenance and plant engineering, assembly of fixtures and in iron, fittings of any kind of items of concrete and reinforced concrete.
- Equipped with double battery 18volts 5.0 Ah Li-Ion, 5 clutch positions adjustable and fixed positions for simple and hammer drilling, electronic speed regulation, electronic brake release the button, switch for use with swing function and drilling / screwing, coated non-slip grip and oil-resistant.
- Nylon plugs 4 x 30 mm on concrete (drilling + installation): n°300
- Nylon plugs 6 x 30 mm on concrete (drilling + installation): n°200
- Holes in concrete 4 x 30 mm: n°350
- Holes in concrete 8 x 30 mm: n°180
- Holes in concrete 10 x 40 mm: n°130
- Holes in concrete 12 x 40 mm: n°60
- Holes in concrete 16 x 40 mm: n°30
- Standard equipment: double lithium battery, super charger, port adapter with quick bits SDS-Plus, di lighting LED working point, carrying case. Dimensions: 64 X 249 X 272 mm. Weight: 2.7 kg with battery.

Code	Desc.
4170020470	EY78A1-LJ2G

Technical Features	
Peso (batterie incluse)	2,7 Kg
Dimensions	64 X 249 X 272 mm
Velocità a vuoto (min/max)	0-1250 rpm
Percussione colpi al minuto	0-4750
Volts	18 Volts
Tempo di ricarica (utilizzabile/100%)	55/70 minutes
Battery capacity	5,0 Ah (Li-Ion)

Spare Parts		
Article	Code	Desc.
Battery Li-Ion 18V-5,0Ah	417RC15300	EY9L53B
Rapid charger	417RC15030	EY0L82B

## Hammer and chisel hammer SDS-Plus 28.8V-3,0Ah



- One of the most compact hammers electro category, equipped with lithium-ion battery, quick coupler of the SDS-Plus, rotation functions with stop and stopping devices rotation for use as a stonemason light. Selecting the hitting power to better suit the characteristics of the material drilled.
- Utensil indicated for all kinds of machining operations especially in the area of maintenance and plant engineering, assembly of fixtures and iron structures, montages of any kind of items of concrete and reinforced concrete.
- Equipped with dual battery from 28.8 volts 3.0 Ah Li-Ion, selectors for rotation with hammering or one line and power of percussion, electronic adjustment of speed, electronic brake button is released, handle coated non-slip and anti-oil, led for lighting the working point.
- Standard equipment: double lithium battery, quick charger, additional handle, depth gauge, carrying case. Dimensions: 83 X 319 X 203 mm. Weight: 3.85 kg with battery.

9

Code	Desc.
4170020040	EY7880LP2C

Spare Parts		
Article	Code	Desc.
Li-Ion 28,8V-3,0Ah	417RC15070	EY9L81B
Quick charger	417RC15030	EY0L82B

Technical Features	
Weight including batteries (kg)	3,85 Kg
Dimensions	83 X 319 X 203 mm
Spindle connection	SDS-Plus
Percussione colpi al minuto (hard)	0-4500
Percussione colpi al minuto (soft)	0-2800
Velocità a vuoto (min/max)	0-920 rpm
Volts	28,8 Volts
Tempo di ricarica (utilizzabile/100%)	67/75 minutes
Battery capacity	3,0 Ah (Li-Ion)

## Cordless professional jig saw 14,4V-4,2Ah



- Powerful and lightweight cordless jigsaw, equipped with the latest lithium-ion battery packs with a capacity of 4.2 Ah. Excellent balancing of the weight and low vibration during operation that allow the execution of precise and perfect cuts on any type of material: metal, wood, plastic and fiber.
- Suitable for work in the areas of carpentry, crafts of each sector, carpentry, furniture assembly, installation work of all types.
- Equipped with a lithium-ion battery, adjustment of cutting 0-45 °, breath of air for cleaning the area of cutting, cutting speed electronically adjustable, adjustment of the pendulum movement of the blade, LED lighting in the area cutting, non-slip rubber coated handle and anti-oil.
- Standard: 1 Lithium battery, quick charger, carrying case. Dimensions: 63 X 277 X 177 mm. Weight: 2.25 kg with battery.

Code	Desc.
4170020050	EY4541-LS1S

Spare Parts			
Article	Code	Desc.	
Li-Ion 14,4V-4,2Ah	417RC15020	EY9L45B	
Quick charger	417RC15030	EY0L82B	
Scratch-resistant suction plate e	417RC15080	1105	

Technical Features	
Weight including batteries (kg)	2,25 Kg
Dimensions	63 X 277 X 177 mm
Spessore massimo delle lame	1,3 mm
Stroke mm	20 mm
Tempo di ricarica (utilizzabile/100%)	50/60 minutes
By minute strokes	2400
Profondità massima di taglio	65 mm
Volts	14,4 Volts
Battery capacity	4,2 Ah (Li-Ion)



## Universal saber saw 18V-5,0Ah



- Universal Saw to "catfish" with powerful 18-volt, battery by the large capacity 5.0 Ah for a long battery life, lightweight, compact and easy to handle.
- Suitable for cutting and demolition in every field of work: carpentry, building demolition, maintenance, auto wreckers, vehicle changes, assembly and modification of structures in general, etc.
- The machine has a fully insulated engine from great power and very compact, speed control via the power button. The internal electronics allows him to work with different voltage batteries, and 14.4 is 18 Volts without any problem and without noticeable performance degradation.
- Mechanics with balancer to limit vibrations, electronic stabilization for a constant speed even under load, standard connection for the use of all the blades present on the market for straight sawing machines.
- Stile pipe Ø 34 mm x spessore 3,2 mm:n° 48
- Stile pipe Ø 49 mm x spessore 3,5 mm:n° 34
- Stile pipe Ø 90 mm x spessore 4,2 mm:n° 13
- Pine wood 38 x 89 mm:n° 85
- Pine wood 38 x 235 mm:n° 55
- Standard equipment: Double lithium battery 18V - 5.0 Ah, quick charger, carrying case.

Code	Desc.
4170020430	EY45A1LJ2G

Technical Features	
Peso (batterie incluse)	3,5 Kg
Dimension mm	87 X 460 X 210 mm
Spessore massimo delle lame	1,6 mm
Volts	18 Volts
Battery capacity	5,0 Ah
Lunghezza della corsa	28 mm
By minute strokes	2800
Tempo di ricarica (utilizzabile/100%)	55/70 minutes

Spare Parts		
Article	Code	Desc.
Battery Li-Ion 18V-5,0Ah	417RC15300	EY9L53B
Rapid charger	417RC15030	EY0L82B

## Multipurpose Circular Saw 18V-5,0Ah - 135mm



- Universal portable circular saw with a powerful engine with 18 Volts, batteries from the large capacity 5.0 Ah for a long battery life, lightweight, compact and easy to handle.
- Suitable for cutting operations in every field of work: carpentry, building demolition, maintenance, vehicles transformations, assembly and modification of structures in general, etc. Changing the type of blade you can cut metals, iron pipes and rods, wood, laminates, fibers, and every kind of building material.
- The machine has a fully insulated engine from great power and very compact, speed control via the power button. The internal electronics allows him to work with different voltage batteries, and 14.4 is 18 Volts without any problem and without noticeable performance degradation.
- Equipped with transparent cover of the blade for a view of the cutting point, LED Lighting, dust extraction with three modes of collection, grip covered slip and oil resistant.
- Metal pipes Ø 25mm thickness 1,2 mm:n° 320
- PVC pipes Ø 34 mm thickness 5 mm:n° 65
- Wood 45 x 45 mm:n° 300
- Thickness plywood 12 mm x 900 mm:n° 130
- Thickness plywood 5 mm x 900 mm:n° 300
- Standard equipment: blade for metal, dual lithium battery 18 V - 5.0 Ah, quick charger, carrying case.

9

Code	Desc.
4170020440	EY45A2LJ2G

Tecnical Features	
Peso (batterie incluse)	2,9 Kg
Dimension mm	160 X 343 X 228 mm
Velocità a vuoto (g/min)	4500 rpm
Profondità massima di taglio	46 mm
Blade external diameter	135 mm
Tempo di ricarica (utilizzabile/100%)	55/70 minutes
Volts	18 Volts
Battery capacity	5,0 Ah

Spare Parts		
Article	Code	Desc.
Battery Li-Ion 18V-5,0Ah	417RC15300	EY9L53B
Rapid charger	417RC15030	EY0L82B
Blade 135 mm for wood	417RC15125	EY9PW13C
Blade 135 mm for thin wood	417RC15130	EY9PW13D
Blade 135 mm for metals	417RC15135	EY9PM13E

## Cordless angle grinder 115/125 mm 18V-5,0Ah



- Compact and powerful battery grinder, equipped with the latest lithium-ion packs 18 Volts Lithium with capacity of 5.0 Ah that give it a very high autonomy. Prepared for the use of standard disks in diameter 115 and 125 mm with a central hole 22,22 mm by cutting or emery.
- Designed for use in any field of work, from auto body shop top handicraft, transformations, carpentry, metal construction, electrical and plumbing installations, construction, maintenance, etc...
- The internal electronics allows him to work with different voltage batteries, and 14.4 is 18 volts with no problem and no significant performance degradation.
- The thin handle allows easy handling possibilities with all the fingers of the hand, the additional handle can be moved from both sides of the head, with lock button for the disk Exchange, steel protective cover, protection against 'accidental starting by inserting the battery with the switch to "oN", anti-oil, non-slip grip.
- Standard equipment: 2 lithium batteries, rapid charger, additional handle, protective cover, carrying case. Dimensions: 105 X 345 X 141 mm. Weight: 2.5 kg with battery.

Code	Desc.
4170020450	EY46A2-LJ2G

Technical Features	
Peso (batterie incluse)	2,5 Kg
Dimensions	105X 345 X141 mm
Velocità a vuoto (RPM)	10.000 rpm
Disc max external diameter	125 mm
Volts	18 Volts
Tempo di ricarica (utilizzabile/100%)	55/70 minutes
Battery capacity	5,0 Ah (Li-Ion)

Spare Parts		
Article	Code	Desc.
Lithium battery 18V - 5,0Ah	417RC15300	EY9L53B
Rapid charger	417RC15030	EY0L82B
Motor brushes	417RC15165	1133A
Headset of protection	417RC15170	1134
Disk mounting flange	417RC15110	1120
Disk fixing nut	417RC15115	1125

## Gun battery sealant 310-400 ml 3.6V-1.5Ah



\* NON UTILIZZABILE PER SIGILLANTI PER CRISTALLI AUTO!

- Gun battery for silicones and sealants both in cartridges of 290-310 ml, in plastic or aluminum, both the bags up to 400 ml. This lightweight, compact, very well balanced for continuous use and not tiring for the operator.
- Suitable for sealing and bonding in all areas is both craft industry. Excellent for sealing fixtures, plumbing fixtures, fittings elements firebreaks, the nautical, gluing tiles, etc.
- High thrust force, battery entirely drowned in the handle and not bulky, electronic speed boost, construction material shockproof rubber coating oil resistant and non-slip holder tube cartridges aluminum. Automatic release arrest to prevent drips. Telescopic push rod to minimize the overall dimensions.
- Standard: 1 Lithium battery and quick charger. Dimensions: 142 X 501 X 259 mm. Weight: 2.15 kg with battery.

Code	Desc.
4170020070	EY3610-LA1J

Spare Parts		
Article	Code	Desc.
Li-Ion to put 3.6V-1.5Ah	417RC15000	EY9L10B
Quick charger	417RC15010	EY0L10B
Thrust pad for pouches	4430055260	1146

Technical Features	
Forza di spinta	2450 N (250 Kgf)
Dimensions	142 X 501 X 259
Tempo di ricarica (utilizzabile/100%)	15/30 minutes
Volts	3,6 Volts
Battery capacity	1,5 Ah
Weight including batteries (kg)	2,15 Kg



## Gun battery sealant 290-400 ml 14,4V-4,2Ah



- Gun battery for silicones and sealants in cartridges of 290 to 310 ml, plastic or aluminum and pouches. Lightweight and compact, well balanced for continuous use and not tiring for the operator. Equipped with the new lithium-ion battery pack with a capacity of 4.2 Ah, which gives it a very high autonomy.
- Suitable for sealing and bonding in all areas is both craft industry. Excellent for sealing fixtures, gluing crystals cars and trucks, hydraulic installations, assemble elements firebreaks, the nautical, gluing tiles, etc.
- High thrust force that it can be used even with very dense sealants, electronic speed boost, construction material shockproof rubber coating oil resistant and non-slip holder tube cartridges aluminum. Automatic release arrest to prevent drips. Push rod rack.
- Standard: 1 Lithium battery, rapid charger and carrying case. Dimensions: 140 X 424 X 245 mm. Weight: 2.65 kg with battery.

Code	Desc.
4170020090	EY3640-LS1S

Spare Parts		
Article	Code	Desc.
Battery Li-Ion 14.4 V-4.2 Ah	417RC15020	EY9L45B
Quick charger	417RC15030	EY0L82B
Thrust pad for pouches	4430055260	1146

Technical Features	
Weight including batteries (kg)	2,65 Kg
Battery capacity	4,2 Ah
Tempo di ricarica (utilizzabile/100%)	50/60 minutes
Forza di spinta	4410 N (450 Kgf)
Dimensions	140 X 424 X 245
Volts	14,4 Volts

## Gun battery sealant 310-600 ml 14,4V-4,2Ah



- Gun battery for silicones and sealants both in cartridges of 290-310 ml, in plastic or aluminum, both the bags up to 600 ml. Lightweight and compact, well balanced for continuous use and not tiring for the operator. Equipped with the new lithium-ion battery pack with a capacity of 4.2 Ah, which gives it a very high autonomy.
- Suitable for sealing and bonding in all areas is both craft industry. Excellent for sealing fixtures, gluing crystals cars and trucks, hydraulic installations, assemble elements firebreaks, the nautical, gluing tiles, etc.
- High thrust force that it can be used even with very dense sealants, electronic speed boost, construction material shockproof rubber coating oil resistant and non-slip holder tube cartridges aluminum. Automatic release arrest to prevent drips. Push rod rack.
- Standard: 1 Lithium battery, rapid charger and carrying case. Dimensions: 140 X 560 X 245 mm. Weight: 2.8 kg with battery.

Code	Desc.
4170020080	EY3641-LS1S

Spare Parts		
Article	Code	Desc.
Li-Ion 14,4V-4,2Ah	417RC15020	EY9L45B
Quick charger	417RC15030	EY0L82B
Thrust pad for pouches	4430055260	1146

Technical Features	
Weight including batteries (kg)	2,8 Kg
Dimensions	140 X 560 X 245
Forza di spinta	4410 N (450 Kgf)
Tempo di ricarica (utilizzabile/100%)	50/60 minutes
Volts	14,4 Volts
Battery capacity	4,2 Ah

## Drill screwdriver kit + impact driver 1/4" 10.8 V – 1.5 Ah



- Kit consisting of Panasonic EY7430 drill driver, our code no. 4170020250, impact driver with female hex coupling (1/4"), portable swivel LED work lamp EY3732B, double lithium ion battery, 10.8 Volts – 1.5 Ah and rapid charger. The kit comes inside a robust tool bag in cordura.
- For drill characteristics, see the code above. The lamp and driver characteristics are provided on this page.

Code	Desc.
4170020390	EYC110LA2L

### Caratteristiche avvitatore EY7530

Volts	10,8 Volts
Capacità batteria	1,5 Ah
Tempo di ricarica (utilizzabile/100%)	40/50 minuti
Coppia massima	90 Nm
Velocità a vuoto	2200 giri/minuto
Numero di colpi al minuto	2700 al minuto
Diametro massimo viti serrabili	M 12
Dimensioni	165 x 180 x 54 mm
Peso	0,98 Kg

### Caratteristiche lampada EY3732B

Volts	10,8 Volts
Capacità batteria	1,5 Ah
Peso escluso batteria	0,14 Kg
Tipo di illuminazione	Led
Luminosità	540 Lux
Ore di utilizzo con batteria al 100%	4 ore

## Drill screwdriver kit + hammer drill 18 V - 5.0 Ah



- Full practical kit consisting of Panasonic EY74A2 drill driver, our code no. 4170020330, and SDS-Plus Panasonic EY78A1 hammer drill, our code no. 4170020470. The kit comes in a hardwearing cordura tool bag, with two lithium ion batteries (18 Volts - 5.0 Ah) and fast charger.
- Machines with brushless motors and maintenance free, both working with 14.4 or 18 Volt batteries, without significant drops in performance.
- For all of the machine characteristics, see the code numbers above.

Code	Desc.
4170020380	EYC2019LJ

## Panasonic machines "X" without batteries

- The range of machines Panasonic "X" in the box provided without batteries and chargers, is born to the customers passionate about the brand, and for those who use and has already supplied its excellent machines. They let you use the batteries of the other power tools, allowing you to create valuable Combo without having to spend money to complete systems, to replace the old machines now but they still have batteries that can be used, and to make the most efficient modular system Panasonic.
- Many of them can work either with batteries 14.4 or 18.0 Volts, with any amperage, without suffering performance degradation evident. To complete the range a portable lamp working, always working with the Panasonic batteries, and a duffel bag / trolley to store all the necessary materials for their work. Made of strong Cordura, it has internal dividers furniture, useful outer and inner pockets, wheels for easy transportation and strong lifting handles.

### Mastic gun 290-310 ml "X"



- Operation with batteries only 14.4 Volts, any amperage. For technical specifications see our article 4170020090-EY3640-LS1S.

Code	Desc.
4170020170	EY3640 X

### Mastic gun 310-600 ml "X"



- Funzionamento solo con batterie da 14,4 Volts, qualsiasi amperaggio. Per le caratteristiche tecniche vedere il nostro articolo 4170020080-EY3641-LS1S.

Code	Desc.
4170020270	EY3641 X



### Impact wrench 1/4 " « X »



- Possibilità di funzionamento con batterie da 14,4 o 18,0 Volts, qualsiasi amperaggio. Per le caratteristiche tecniche vedere il nostro articolo 4170020340-EY75A7-LJ2F.

Code	Desc.
4170020360	EY75A7 X

### Impact wrench 1/2 "" X "



- Operation with batteries 14.4 or 18.0 Volts, any amperage. For technical specifications see our article 4170020120-EY75A2-LS2G.

Code	Desc.
4170020200	EY75A2 X

### Angle grinder 115/125 mm "X"



- Operation with batteries 14.4 or 18.0 Volts, any amperage. For technical specifications see our article 4170020260-EY42A2-LS2G.

Code	Desc.
4170020240	EY46A2 X

## 135mm multi-purpose circular saw "X"



- Possibilità di funzionamento con batterie da 14,4 o 18,0 Volts, qualsiasi amperaggio. Per le caratteristiche tecniche vedere il nostro articolo 4170020140-EY45A1-LS1G.

Code	Desc.
4170020210	EY45A2 X

## Universal saber saw "X"



- Possibilità di funzionamento con batterie da 14,4 o 18,0 Volts, qualsiasi amperaggio. Per le caratteristiche tecniche vedere il nostro articolo 4170020130-EY45A1-LS1G.

Code	Desc.
4170020190	EY45A1 X

## Cordless rotary-percussive drill "X"



- Version without batteries Cordless rotary-drill our code 4170020470-EY78A1-LJ2G.
- Operation with batteries 14.4 or 18.0 Volts, any amperage. For technical specifications see the above model.

Code	Desc.
4170020490	EY78A1-X

### Screwdriver drill 14.4-18.0 V “X”



- Possibility to work with 14.4 or 18.0 Volt batteries and any amperage. For the technical characteristics, see our item 4170020330-EY74A2-LJ2G.

Code	Desc.
4170020550	EY74A2-X

### Hammer drill 14.4-18.0 V “X”



- Possibility to work with 14.4 or 18.0 Volt batteries and any amperage. For the technical characteristics, see our item 4170020320-EY79A2-LJ2G.

Code	Desc.
4170020590	EY79A2-X

## Halogen lamp portable "X"



- Lampada portatile fornita senza batterie e caricabatterie, funzionamento con qualsiasi pacco batterie Panasonic con voltaggio da 14,4/18,0/21,6 Volts, qualsiasi amperaggio. Dotata di lampada xenon dalla forte luminosità.
- Con batteria da 14,4 Volts 4,2 Ah montata ha una durata fino a 5 ore. Testa orientabile su quattro posizioni, ampia base di appoggio per la massima stabilità. Luminosità raggiunta di circa 4000 lux, angolo di illuminazione molto ampio.

Code	Desc.
4170020180	EY37C1 B

Tecnical Features	
Dimension mm	90 X 124 X 279
Peso escluso batteria	0,34 Kg
Ore di utilizzo con 14,4 V - 4,2 Ah	5,00 H
Luminosità	ca. 4000 Lux
Volts	21,6/18,0/14,4
Lampadina	Xenon 0,7 A
Battery capacity	4,2/3,3/3,1/1,5 Ah (Li-Ion)

Spare Parts	
Code	Description
417RC15195	Coppia lampade di ricambio

## Bag technique / trolley Panasonic



- Dimensions open: 700x400x300 mm



Code	Description
4170020220	Bag technique Panasonic



## Battery tapper M4 – M12



- Three-function machine: drill, screwdriver, and tapper with automatic reversal of the direction of rotation. Indispensable for quick and very easy tapping operations also repetitive. Ability to operate with taps having diameter from M4 to M12.
- It can be used in any workshop and in any construction site to make threading or to rework and clean the same.
- It is equipped with dual quick-change mandrel for cylindrical bits and square-attachment tools. Double mechanical speed, electronic torque adjustment, which stops the machine when reaching the value set, lightning of the working point, reversibility and brushless motor for a minimal maintenance.
- Pulse operation that can be activated to release blocked screws or start drilling on smooth surfaces. Hollow mandrel holder shaft with 1/4" hex for direct insertion of bits. Electronic overload protection of the machine, multi-purpose collar of 43 mm diameter.
- Supplied as standard: quick-change mandrel for taps M4-M6, quick-change double mandrel for taps M8-M12, additional handle, dual Lithium battery 18 Volts - 5.5 Ah, fast battery charger, plastic case.

9

Code	Description
4170040350	GB18LTX

Technical Features	
Weight including batteries (kg)	2,5 Kg
Spindle opening	1,5-13 mm
N° giri a vuoto 1° e 2° veloc.	0-600/0-2050 giri/min.
Ø max foratura nel legno	65 mm
Diametri filettature	M4-M12
Ø max foratura nell'acciaio	13 mm
Maximum torque	120 Nm
Regolazione della coppia	1-20 Nm
Battery capacity	5,5 Ah
Battery type	Li-Ion
Battery voltage	18 Volts

Vibrazioni	
Foratura su metallo	3,2 m/s <sup>2</sup>
Insicurezza della misurazione K	1,5 m/s <sup>2</sup>
Emissioni acustiche	
Livello di pressione acustica	78 dB(A)
Livello di potenza sonora (LwA)	89 dB(A)
Insicurezza della misurazione K	3 dB(A)

## Aspiratore – soffiatore a batteria 7,5 L



- Potente aspiratore – soffiatore professionale per l’aspirazione ed il soffiaggio in ogni luogo, grazie all’alimentazione tramite batterie da 18 Volts al Litio. Capacità del serbatoio di 7,5 litri.
- Utilizzabile per ogni operazione di pulizia industriale, nella manutenzione termoidraulica, nei cantieri, per la pulizia di autoveicoli, ecc.
- Dotato di sacchi intercambiabili in tessuto non tessuto per la raccolta dello sporco, filtro ripulibile con certificazione di categoria L, tubo flessibile diametro 27 mm lunghezza 3 metri.
- Possibilità di pulizia del filtro di tipo manuale tramite un potente getto d’aria interno, funzione di soffiaggio integrata che inverte il funzionamento del motore per soffiare ed asciugare, doppio funzionamento: eco per la maggior durata della carica delle batterie, boost per la maggiore potenza. Grande interruttore di accensione utilizzabile anche con i piedi. Trasporto tramite maniglia o tracolla.
- La macchina è contenuta in un box in materiale antiurto impilabile con tutte le valigette Metabo con sistema Metaloc. Tutti gli accessori hanno alloggiamenti all’interno del box.
- Dotazione di serie: tubo flessibile di aspirazione diametro 27 mm lunghezza 3 metri, sacchetto filtrante in tessuto non tessuto, bocchetta di aspirazione larghezza 120 mm, bocchetta di aspirazione piatta, cinghia per tracolla, doppia batteria a Litio da 18 Volts – 5,2 Ah, caricabatterie rapido.

Code	Description
4170040360	AS18LPC

Spare Parts		
Article	Code	Desc.
Sacchetti raccogli polvere 5 pezzi	417RC18020	1372

Tecnical Features	
Weight including batteries (kg)	7,4
Lunghezza tubo flessibile di aspirazione	3 m
Ø tubo flessibile di aspirazione	27 mm
Tank capacity	7,5 L
Superficie di filtraggio	3600 cmq
Depressione	120 hPa (mbar)
Volume max d’aria aspirato	2100 L/minuto
Battery capacity	5,2 Ah
Battery voltage	18 Volts
Battery type	Li-Ion

Emissione acustica	
Livello di pressione acustica	72 dB(A)
Livello di potenza sonora (LwA)	84 dB(A)
Insicurezza della misurazione K	2,4 dB(A)

## Reel mural for high water pressure



- Retractor fixed wall with a rubber hose to pass high-pressure water inside diameter 3/8 "(9.5 mm), max 200 bar and maximum temperature of 155 ° C. Ideal for connection to a water cleaning machines both cold and hot.
- Indicated for use in workshops, car washes and industries generally. Can be installed on the wall or floor.
- Reel port tube high strength polymer, support brackets fixed galvanized steel, stop device of the pipe to the desired length, hose stop buffer.
- Incoming attack on the swivel: 1/2 "male. Attack output: 3/8 "female. Tube length: 15 meters.
- With reduction 1/2 "F-3/8" male.

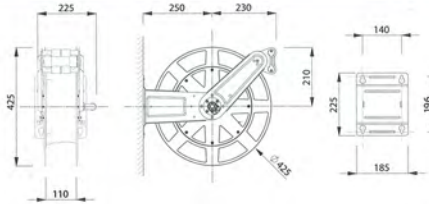

Code	Desc.
3450100700	1707

## Cold high pressure washer high pressure 130 bar - 600 l/h

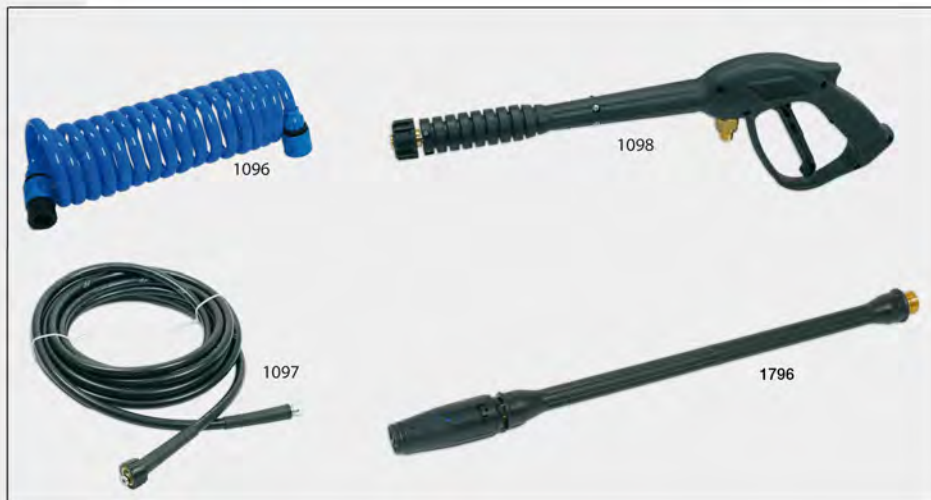

- Professional high pressure washer high pressure, functioning to cold water with or without detergents, with a hose reel, the reservoir for cleaning agents and rubber wheels for easy displacement.
- Suitable for quick and easy cleaning of vehicles, industrial floors, exterior walls, fences, industrial, motorcycles and scooters, equipment in general.
- With the kit on request and 'used to unclog clogged drain pipes.
- Useful for all business fields: mechanical, body shops, drivers, artisans typically, maintenance, etc.
- Three axial piston pump with ceramic rod / crank pressure adjustable output, automatic safety valve with pressure in the head, single phase electric motor with thermal protection, motor quiet, shock-proof plastic casing resistant and easy to clean.
- Total stop: high pressure cleaner shutdown system when not in use.
- Standard equipment: hose reel, rubber wheels of large diameter, high pressure hose of 10 meters, dispensing gun, lance with adjustable nozzle direct or fan, reservoir for application of detergents.

9

Code	Desc.
4430058490	RLW 767

Tecnical Features		Spare Parts		
		Article	Code	Description
Weight kg	36			
Dimensions Length x Depth x H (cm)	39 X 38 X 90	Pipe for water connection 4.5 m	4430054100	1096
Giri motore (rpm)	1450	High pressure hose 10 m	4430054105	1097
Power output (Kw)	2,6	Lance Handle	4430054110	1098
Pression max (bar)	150	Spare wheel	4430055765	1505
Portata d'acqua (l/h)	600	Spare lance	4430058500	1796
Minimum supply hose diameter (mm)	13			
High pressure hose threaded connection and accessories	M 22X1,5			
Lunghezza tubo alta pressione (m)	10			
Power supply cable length (m)	5			
Tensione di alimentazione (V/Hz)	220/50			



## Jet lance rotating pressure washer RLW767 - AR4550



- Jet lance round that form a powerful jet and rotating at high speed, the reduced diameter of the rotation allows him to impress firmly as possible to the jet.
- Ideal for fast and precise cleaning of stubborn dirt resistant, and cleaning of machinery and equipment or agricultural.
- **WARNING:** Do not use on motor vehicle bodies.

Code	Desc.
4430054020	1088

## Rotating brush with tank cleaner pressure washer RLW 767



- Rotary brush cleaner for Meccanocar RLW 757, complete with automatic tank for dispensing of the detergent.
- Ideal for intensive washing of cars, vans, campers, awnings, boats, wooden buildings, fixtures, etc.
- The softness of the brush allows its use on any surface, even the most 'delicate. The rotating brushes, combined delivery of detergent, allow to remove the dirt more 'tenacious hold without preventing scratches and tarnishing and removing the need for hot water, especially on the means of transport very dirty.

Code	Desc.
4430054030	1089

## Kit cleaning pipes for pressure washer RLW 767



- High-pressure piping with special head power, to release any type of pipe clogged by waste.
- Ideal for freeing domestic sewage, underground pipes, rain gutters, plumbing, etc .. The special head has a central jet that breaks through the shutter, and the side shoots that push forward into the pipe and clean it thoroughly the walls.
- It applies easily handle standard, which allows the drive. Available in lengths of 8 m to 16 m.

Code	Desc.	Length m
4430054040	1090	8
4430054050	1091	16

## Hot high pressure washer 150 bar 380V-900 liters / h



- Professional high pressure washer high pressure, with a boiler for heating water, the reservoir for cleaning agents and rubber wheels for easy displacement.
- Suitable for quick and easy cleaning of vehicles, industrial floors, exterior walls, fences, industrial vehicles, motorcycles and scooters, equipment in general.
- Useful for all business fields: mechanical, body shops, truck drivers, bus companies, craftsmen in general, maintenance, car washes, etc.
- Pump with three ceramic pistons, rod / crank pressure adjustable output, automatic safety valve with pressure in the head, three-phase electric motor with thermal protection, system Machine total stopping distance, silent motor, housing material shock resistant and easy to clean.
- Vertical boiler with cooling spiral, bottom refractory. Precision thermostat for temperatures from 30 to 150 ° C (with inlet water at 60 ° C), safety pressure switch for lack of water, water filter and diesel fuel.
- Standard: rubber wheels of large diameter, high-pressure pipe 1 0 meters, dispensing gun, lance with fan jet, tank for the application of detergents.
- \* ATTENTION: the spears are sold without nozzle, to be ordered separately.

Code	Desc.
4430054091	AR7850

Tecnical Features		Spare Parts		
Tensione di alimentazione (V/Hz)	380/50	<b>Article</b>	<b>Code</b>	<b>Description</b>
Power supply cable length (m)	10	High pressure hose 10 m	4430054121	1100/10A
Lunghezza tubo alta pressione (m)	10	High pressure hose 20 m	4430054146	1105/20
High pressure hose threaded connection and accessories	M 22X1,5	Lance handle	4430054126	1101/A
Minimum supply hose diameter (mm)	13	Lance to handle *	4430054131	1102/A
Portata d'acqua (l/h)	900	Lance 2m to handle *	4430054150	1106
Pression max (bar)	150	Fan nozzle 1/4 "for lance *	4430054136	1103/A
Fuel tank capacity (l)	15			
Detergent tank capacity (l)	4			
Temperatura acqua (°C)	30 - 150			
Power output (Kw)	4,0			
Giri motore (rpm)	1450			
Dimensions Length x Depth x H (cm)	98 X 59 X 92			
Weight kg	94			

## Hose reel AP pressure washers AR 7850-8860



- Reel manual for the correct positioning of the high pressure hose on pressure washers hot Meccanocar AR7850-AR8860
- Kit complete with mounting hardware. It allows to keep the machinery in order in the best way, and keep the pipe AP protected from abrasion and crushing.

Code	Desc.
4430054140	1104

## Jet lance rotating pressure washer AR7850



- Lance with round nozzle that forms a powerful jet and rotating at high speed, the restricted diameter of the rotation allows him to impress firmly as possible to the jet.
- Ideal for fast and precise cleaning of stubborn dirt resistant, and cleaning of machinery and equipment or agricultural.
- **WARNING:** Do not use on motor vehicle bodies.

Code	Desc.
4430054025	1088/A

## Rotating brush for pressure washers AR 7850-8860



- Rotating brush for pressure washers hot Meccanocar AR-7850 AR 8860.
- Ideal for intensive washing of cars, vans, campers, awnings, boats, wooden buildings, fixtures, etc ..
- The softness of the brush allows its use on any surface, even the most delicate. The rotating brushes, combined delivery of detergent, allow to remove stubborn dirt without holding, preventing scratches and tarnishing especially on the means of transport very dirty.

Code	Desc.
4430054095	1095

## Hot high pressure washer 200 bar 380V-1260 liters / h



- Professional high pressure washer high pressure, with a boiler for heating water, the reservoir for cleaning agents and rubber wheels for easy displacement. High pressure and water flow rate for easy descaling of dirt more 'intense and difficult.
- Suitable for intensive cleaning of vehicles, industrial floors, exterior walls, fences, industrial vehicles, construction equipment and quarrying, construction equipment, equipment in general.
- Useful for all business fields: mechanical, body shops, drivers, artisans typically, maintenance, car washes, farms, shipyards, dry docks, construction sites, etc.
- Pump with three ceramic pistons, rod / crank pressure adjustable output, automatic safety valve with pressure in the head, three-phase electric motor with thermal protection, system Machine total stopping distance, silent motor, housing material shock resistant and easy to clean.
- Vertical boiler with cooling spiral, bottom refractory. Precision thermostat for temperatures from 30 to 150 ° C (with inlet water at 60 ° C), safety pressure switch for lack of water, water filter and diesel fuel.
- Standard: rubber wheels of large diameter, high pressure hose of 10 meters, dispensing gun, lance with fan jet, tank for the application of detergents.
- CAUTION: the current consumption of very important of the machine requires a power supply of at least 7.4 kW. Using extension cords with electric cables must be made with the most 'short as possible and suitable section.
- \* ATTENTION: the spears are sold without nozzle, to be ordered separately.

9

Code	Desc.
4430054092	AR8860

Tecnical Features		Spare Parts		
		Article	Code	Description
Weight kg	135			
Dimensions Length x Depth x H (cm)	112 X 73 X 106	High pressure hose 10 m	4430054122	1100/10B
Giri motore (rpm)	1450	High pressure hose 20 m	4430054146	1105/20
Power output (Kw)	7,4	Lance Handle	4430054126	1101/A
Temperatura acqua (°C)	30 - 150	Lance to handle *	4430054131	1102/A
Detergent tank capacity (l)	8	Lance 2m to handle *	4430054150	1106
Fuel tank capacity (l)	15	Fan nozzle 1/4 "for lance *	4430054137	1103/B
Pression max (bar)	200			
Minimum supply hose diameter (mm)	13			
Portata d'acqua (l/h)	1260			
High pressure hose threaded connection and accessories	M 22X1,5			
Power supply cable length (m)	10			
Lunghezza tubo alta pressione (m)	10			
Tensione di alimentazione (V/Hz)	380/50			



# Angular grinder 750W – 115 mm



- Compact angular grinder, handy and light, suitable for all types of jobs. Equipped with a 750W motor, possibility of mounting 115 mm discs with a standard 22.2 mm hole.
- Indicated for light/medium grinding jobs, cutting and sanding in all sectors: metalwork, metal processing, car body shops, etc..
- Powerful motor with a high resistance to overloads, torque-resistant protective guard and anti-restart protection that stops accidental restarts following an interruption to the power supply. Motor equipped with self-releasing brushes to protect the armature.
- Supplied as standard: supplementary handgrip, protective steel guard, nut and flange for fixing the discs and a spanner for fixing the discs. Supplied in a cardboard box.

9

Code	Desc.
4170040010	W750-115

Spare Parts			
Article	Code	Desc.	
Pare brush pair	417RC16300	1240	
Disc blocking flange	417RC16310	1241	
Disc locking nut	417RC16320	1242	
Supplementary handgrip	417RC16330	1243	
Supplementary vibration-resistant handgrip	417RC16340	1244	
Protective cap	417RC16350	1245	

Technical Features	
Cable length	2,5 m
Weight without cable	1,8 Kg
Dimensions	351 x 234 x 99 mm
Grinder diameter	115 mm
Max. Power	750 W
Max. revolutions when idling No.	11.000/minutes
Shaft threading	M14
Max torque	1,7 Nm

Vibrations	
Sanding with disc	10 m/s <sup>2</sup>
Uncertainty of the measurement K	1.5 m/s <sup>2</sup>
Sanding utilising an abrasive sheet	5 m/s <sup>2</sup>
Uncertainty of the measurement K	1.5 m/s <sup>2</sup>
Acoustic emissions	
Sound pressure level	88 dB(A)
Sound power level	99 dB(A)
Uncertainty of the measurement K	3 dB(A)

## Angular grinder 900W – 115 mm

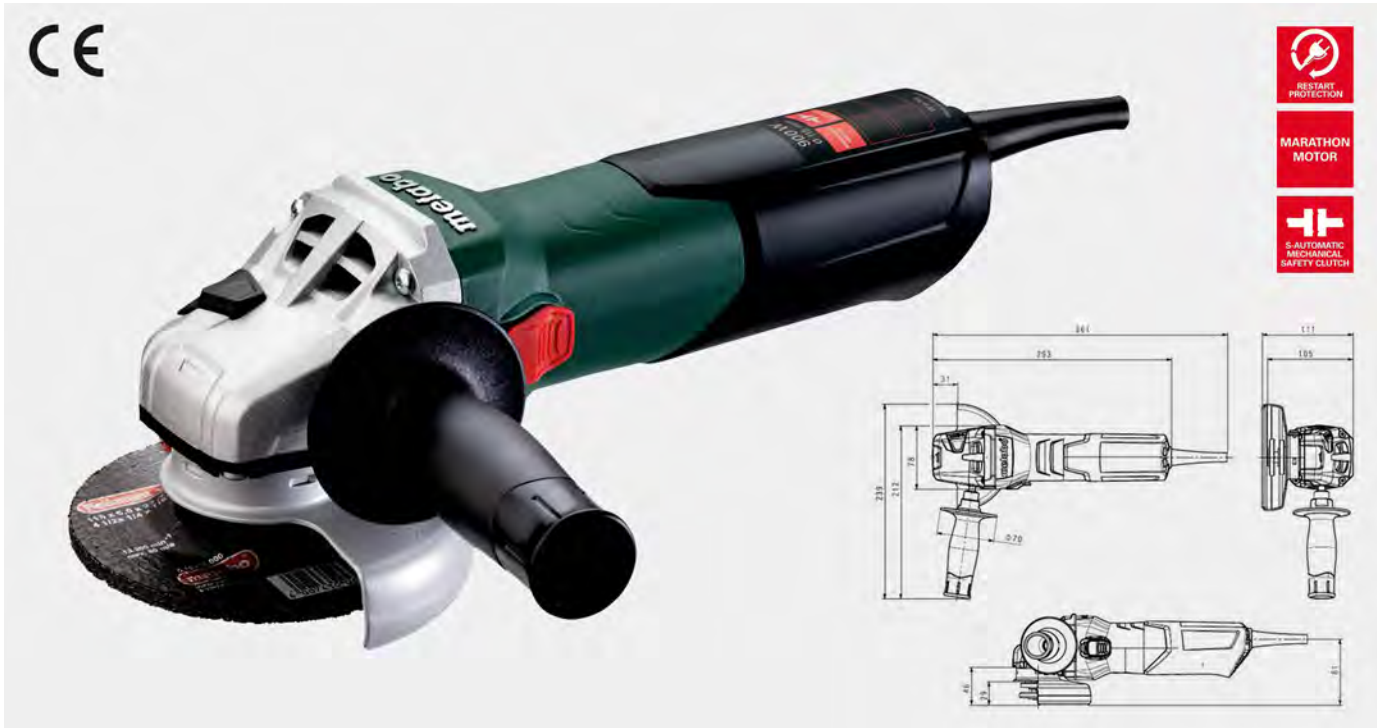

- Compact angular grinder, handy and light, suitable for all types of jobs. Equipped with the new Metabo Marathon motor (patent deposited) with up to 50% more torque and up to 20% more resistance to overloads that gives a greater removal performance and is more long lasting.
- Indicated for grinding jobs, cutting and sanding in all sectors: metalwork, metal processing, car body shops, etc..
- Even less tiring: compact angular grinders with the slimmest handgrip in its power class for perfect ergonomic.
- Powerful motor with a high resistance to overloads, torque-resistant protective guard and anti-restart protection that stops accidental restarts following an interruption to the power supply. Equipped with self-releasing brushes to protect the armature.
- Metabo S-automatic mechanical safety clutch: reduces recoil when the grindstone blocks that is the lowest level on the market. Maximum protection for the operator and less time taken to restart work.
- 90° pitch, revolving and fixed gearhead to permit the left-handed utilisation or for breaking off.
- Supplied as standard: Supplementary handgrip, steel protective guard positioned without using tools, nut and flange for fixing discs and key for blocking the discs. Supplied in a cardboard box.

9

Code	Desc.
4170040020	W9-115

Spare Parts		
Article	Code	Desc.
Spare parts - pair of brushes	417RC16360	1246
Disc blocking flange	417RC16310	1241
Disc locking nut	417RC16320	1242
Supplementary handgrip	417RC16330	1243
Supplementary vibration-resistant handgrip	417RC16340	1244
Protective cap	417RC16370	1247

Technical Features	
Cable length	2,5 m
Weight without cable	2,1 Kg
Grinder diameter	115 mm
Max. Power	900 W
Max. revolutions when idling No.	10.500/minute
Max torque	2,5 Nm
Dimensions	361 x 239 x 111 mm
Shaft threading	M 14

Vibrations	
Sanding with disc	4.9 m/s <sup>2</sup>
Uncertainty of the measurement K	1.5 m/s <sup>2</sup>
Sanding utilising an abrasive sheet	2.5 m/s <sup>2</sup>
Uncertainty of the measurement K	1.5 m/s <sup>2</sup>
Acoustic emissions	
Sound pressure level	93 dB(A)
Sound power level	104 dB(A)
Uncertainty of the measurement K	3 dB(A)

# Angular grinder 1100W – 125 mm



- Compact angular grinder, handy and light, suitable for all types of jobs. Equipped with a 1100 W motor, possibility of mounting 125 mm discs with a standard 22.2 mm hole.
- Indicated for grinding jobs, cutting and sanding in all sectors: metalwork, metal processing, car body shops, etc..
- Powerful motor with a high resistance to overloads, torque-resistant protective guard and anti-restart protection that stops accidental restarts following an interruption to the power supply. Motor equipped with self-releasing brushes to protect the armature.
- Supplied as standard: Supplementary handgrip, steel protective guard positioned without using tools, nut and flange for fixing discs and key for blocking the discs. Supplied in a cardboard box.

9

Code	Desc.
4170040030	W1100-125

Spare Parts			
Article	Code	Desc.	
Spare parts - pair of brushes	417RC16380	1248	
Disc blocking flange	417RC16310	1241	
Disc locking nut	417RC16320	1242	
Supplementary handgrip	417RC16330	1243	
Supplementary vibration-resistant handgrip	417RC16340	1244	
Protective cap	417RC16390	1249	

Technical Features	
Cable length	2,5 m
Weight without cable	1,8 Kg
Dimensions	351 x 234 x 99 mm
Shaft threading	M 14
Max. revolutions when idling No.	11.000/minute
Max torque	1,7 Nm
Grinder diameter	125 mm
Max. Power	1.100 W

Vibrations	
Sanding with disc	6 m/s <sup>2</sup>
Uncertainty of the measurement K	1.5 m/s <sup>2</sup>
Sanding utilising an abrasive sheet	4.2 m/s <sup>2</sup>
Uncertainty of the measurement K	1.5 m/s <sup>2</sup>
Acoustic emissions	
Sound pressure level	91 dB(A)
Sound power level	102 dB(A)
Uncertainty of the measurement K	3 dB(A)



## Angular grinder 1550W – 125 mm with speed adjustment



- Compact angular grinder, handy and light, suitable for all types of jobs. Equipped with the new Metabo Marathon motor with up to 50% more torque and up to 20% more resistance to overloads that gives a greater removal performance and is more long lasting.
- Indicated for demanding and finishing jobs with all types of abrasives, thanks to the speed adjustment that adapts to all types of required finish. Optimum for processing metals such as stainless steel, titanium, brass, bronze, etc.
- Powerful motor with a high resistance to overloads, torque-resistant protective guard and anti-restart protection that stops accidental restarts following an interruption to the power supply. Equipped with self-releasing brushes to protect the armature.
- Metabo S-automatic mechanical safety clutch: reduces recoil when the grindstone blocks that is the lowest level on the market. Maximum protection for the operator and less time taken to restart work.
- 90° pitch, revolving and fixed gearhead to permit the left-handed utilisation or for breaking off.
- Supplied as standard: Supplementary handgrip, steel protective guard positioned without using tools, nut for fixing discs "Quick" for tool-free assembly, flange for blocking the discs. Supplied in a plastic case.

Code	Desc.
4170040040	W15-125Q

Spare Parts			
Article	Code	Desc.	
Spare parts - pair of brushes	417RC16400	1250	
Disc blocking flange	417RC16310	1241	
Disc locking nut	417RC16320	1242	
Supplementary handgrip	417RC16330	1243	
Supplementary vibration-resistant handgrip	417RC16340	1244	
Protective cap	417RC16410	1251	

Technical Features	
Cable length	4 m
Weight without cable	2,5 Kg
Dimensions	383 x 248 x 111 mm
Shaft threading	M 14
Max torque	3,5 Nm
Grinder diameter	125 mm
Max. Power	1550 W
Max. revolutions when idling No.	2.800-11.000/minute

Vibrations	
Sanding with disc	6 m/s <sup>2</sup>
Uncertainty of the measurement K	1.5 m/s <sup>2</sup>
Sanding utilising an abrasive sheet	3.6 m/s <sup>2</sup>
Uncertainty of the measurement K	1.5 m/s <sup>2</sup>
Acoustic emissions	
Sound pressure level	93 dB(A)
Sound power level	104 dB(A)
Uncertainty of the measurement K	3 dB(A)



# Angular grinder 1900W – 180 mm



- Compact, angular grinder with a powerful Metabo Marathon motor for intensive work of cutting and grinding with 180 mm diam. discs. The same cutting depth of a 230 mm grinder with only half the weight.
- Indicated for heavy grinding jobs, cutting and sanding in all sectors: metalwork, metal processing, construction sites, etc.
- Powerful motor with a high resistance to overloads, torque-resistant protective guard that can be positioned without using tools, and anti-restart protection that stops accidental restarts following an interruption to the power supply. Motor equipped with self-releasing brushes to protect the armature.
- Equipped with an electronic control for slow start-up and no recoil, constant speed of the discs even under load, mechanical safety clutch that blocks the disc in the case blocking, thereby avoiding recoil for the operator.
- It is supplied with a supplementary vibration-resistant handgrip and also the possibility of rotating the gear head in steps of 90° to adapt it to all types of work. "M-Quick" disc locking nut for fixing and disassembly without tools.
- Supplied as standard: supplementary vibration-resistant handgrip, protective steel guard, M-Quick nut and flange for fixing the discs. Supplied in a cardboard box.

Code	Desc.
4170040270	WE19-180QRT

Spare Parts			
Article	Code	Desc.	
Spare parts - pair of brushes	417RC17380	1342	
Disc blocking flange	417RC16310	1241	
Disc locking nut	417RC16320	1242	
Supplementary vibration-resistant handgrip	417RC16440	1254	
Protective cap	417RC17390	1343	

Technical Features	
Cable length	4 m
Weight without cable	2,7 Kg
Max torque	5 Nm
Dimensions	495 x 348 x 149
Shaft threading	M 14
Max. revolutions when idling No.	8.200/minute
Max. Power	1900 W
Grinder diameter	180 mm

Vibrations	
Sanding with disc	7.7 m/s <sup>2</sup>
Uncertainty of the measurement K	1.5 m/s <sup>2</sup>
Sanding utilising an abrasive sheet	2.8 m/s <sup>2</sup>
Uncertainty of the measurement K	1.5 m/s <sup>2</sup>
Acoustic emissions	
Sound pressure level	94 dB(A)
Sound power level	105 dB(A)
Uncertainty of the measurement K	3 dB(A)

## Angular grinder 2400W – 230 mm



- Angular grinder with a contained weight, equipped with a powerful, 2,400W slow start motor. Supplementary handgrip mountable in three positions.
- Indicated for heavy grinding jobs, cutting and sanding in all sectors: metalwork, metal processing, construction sites, etc.
- Powerful motor with a high resistance to overloads, torque-resistant protective guard and anti-restart protection that stops accidental restarts following an interruption to the power supply. Motor equipped with self-releasing brushes to protect the armature.
- Supplied as standard: supplementary handgrip, protective steel guard, nut and flange for fixing the discs and a spanner for fixing the discs. Supplied in a cardboard box.

Code	Desc.
4170040050	WX2400-230

Spare Parts			
Article	Code	Desc.	
Spare parts - pair of brushes	417RC16420	1252	
Disc blocking flange	417RC16310	1241	
Disc locking nut	417RC16320	1242	
Supplementary handgrip	417RC16430	1253	
Supplementary vibration-resistant handgrip	417RC16440	1254	
Protective cap	417RC16450	1255	

Technical Features	
Cable length	4 m
Weight without cable	6,2 Kg
Shaft threading	M 14
Dimensions	495 x 348 x 149
Grinder diameter	230 mm
Max. revolutions when idling No.	6.600/minuto
Max. Power	2400 W

Vibrations	
Sanding with disc	8.1 m/s <sup>2</sup>
Uncertainty of the measurement K	1.5 m/s <sup>2</sup>
Sanding utilising an abrasive sheet	2.5 m/s <sup>2</sup>
Uncertainty of the measurement K	1.5 m/s <sup>2</sup>
Acoustic emissions	
Sound pressure level	94 dB(A)
Sound power level	105 dB(A)
Uncertainty of the measurement K	3 dB(A)

# Electronic straight grinder 710W – 6 mm



- Compact, straight grinder of a reduced weight with 710W of high power. Equipped with electronic speed adjustment and speed maintained when under load. Prolonged shaft with a removable rubber finish for maximum ease of handling and processing precision.
- Ideal for all types of precision processing on metals with the utilisation of milling cutters with a 6 mm cylindrical shaft.
- Supplied as standard: shaft lock button for simple substitution of tools, die-cast aluminium bearing holder flange for a long working life of the grinder, Vario-Constamatic (VC) electronics to work materials at sufficient speed that remains constant even under load.
- Electronic safety stop of the motor when the tool is blocked so as to operate in complete safety, anti-restart protection: blocks the accidental restart after an interruption to the power supply, electronic protection of the motor against overloads for a longer working life.
- Equipped with the new Metabo Marathon motor with dust-resistant protection (patent deposited) for an optimum protection and long-wearing over a long period of time.
- Supplied as standard: pincer with a 6 mm nut, rubber protective cap and a service key. Supplied in a cardboard box.

9

Code	Desc.
4170040060	GE710P

Spare Parts		
Article	Code	Desc.
Spare parts - pair of brushes	417RC16460	1256
Pincer with a 6 mm nut	417RC16470	1257
Pincer with a an 8 mm nut	417RC16480	1258

Technical Features	
Cable length	4 m
Weight without cable	1,6 Kg
Apertura della pinza	6 mm
Collar diameter	43 mm
Max. Power	710 W
Max. revolutions when idling No.	10.000-30.500/minute

Vibrations	
Sanding of surfaces	5.6 m/s <sup>2</sup>
Uncertainty of the measurement K	1.5 m/s <sup>2</sup>
Acoustic emissions	
Sound pressure level	80 dB(A)
Sound power level	91 dB(A)
Uncertainty of the measurement K	3 dB(A)



## Levigatrice rotorbitale palmare 350 W – 2,5 mm



- Levigatrice rotorbitale palmare con platorello velcrato multiforo da 150 mm, compatta e molto ergonomica, con regolazione di velocità elettronica per adattarsi a tutti i tipi di abrasivo utilizzati.
- Orbita da 2,5 mm indicata per lavorazioni che richiedono la massima finitura con un buon grado di asportazione nei settori dell'autocarrozzeria, su superfici grezze e verniciate o su stucchi, nella falegnameria e in tutti i settori per la lavorazione di resine, plastiche, metalli, legni, ecc.
- Funzionamento sicuro e duraturo assicurato dal nuovissimo motore ultracompatto senza spazzole. Bassissima emissione di vibrazioni alle mani dell'utilizzatore.
- Impugnatura palmare con interruttore/regolatore di velocità a leva, preselezione elettronica della velocità massima, avviamento lento, freno motore del platorello per poter appoggiare velocemente la macchina, mantenimento elettronico della velocità anche sotto sforzo.
- Dotata di aspirazione integrata delle polveri per usarla con un aspirapolvere, cavo velocemente intercambiabile ad attacco rapido.
- Dotazione di serie: platorello multiforo di diametro 150 mm fissaggio velcro, chiave di servizio. Fornita in scatola di cartone.

Code	Desc.
4170040250	SXE150-2.5BL

Spare Parts		
Article	Code	Desc.
150 mm multi-drilled pad	417RC17400	1344
Spare part power supply cable	417RC17410	1345

Technical Features	
Cable length	4,3 m
Weight without cable	1 Kg
Orbit diameter	2,5 mm
Pad diameter	150 mm
Max. revolutions when idling No.	4.000 - 10.000/minute
Max. Power	350 W

Acoustic emissions	
Sound pressure level	71 dB(A)
Sound power level	82 dB(A)
Uncertainty of the measurement K	2 dB(A)



# Hand-held orbital sander, 350W – 5.0 mm



- Hand-held sander with 150 mm, multi-drilled, Velcro pad with the same technical characteristics as our model, code 4170040250-SXE150-2.5BL, but with an orbital diameter of 5.0 mm to ensure a much faster dust removal with a lesser degree of finish.
- The 5.0 mm orbit permits much quicker work processing and dust removal in the bodyshop sector, on unfinished and painted surfaces or on stucco, in woodwork departments and in all sectors for the processing of resin, plastics, metals, woods, etc.



Code	Desc.
4170040240	SXE150-5.0BL

Spare Parts		
Article	Code	Desc.
150 mm multi-drilled pad	417RC17400	1344
Spare part power supply cable	417RC17410	1345

Technical Features	
Cable length	4,3 m
Weight without cable	1 Kg
Orbit diameter	5,0 mm
Max. revolutions when idling No.	4.000 – 10.000/minute
Pad diameter	150 mm
Max. Power	350 W

Acoustic emissions	
Sound pressure level	71 dB(A)
Sound power level	82 dB(A)
Uncertainty of the measurement K	2 dB(A)

## 310 W - 150 mm rotary orbital sander



- Compact and very ergonomic rotary orbital sander with 150 mm velcro pad with electronic speed adjustment to adapt to all types of abrasive materials utilised.
- Indicated for processing untreated and painted metals, wood and plastics. Work processing in carpentry shops, body shops, preparation for painting and the removal of old paints, etc.
- Softgrip slip-resistant handgrip even for hand processing, solid bearing housing in die-cast aluminium, work processing with less vibration, thanks to the well-balanced mechanism.
- Easy to empty fabric dust bag to work without vacuum extraction, or the possibility of a vacuum extractor thanks to the connection to a universal extractor.
- Supplied as standard: 150 mm velcro fixing, multi-drilled pad, service key, fabric dust bag. Supplied in a plastic case.

Code	Desc.
4170040070	SXE3150

Spare Parts		
Article	Code	Desc.
Spare parts - pair of brushes	417RC16490	1259
150 mm multi-drilled pad	417RC16500	1260
Fabric dust bag	417RC16510	1261

Technical Features	
Cable length	4 m
Orbit diameter	3 mm
Weight without cable	1,6 Kg
Pad diameter	150 mm
Max. revolutions when idling No.	4.000 - 12.000/minute
Max. Power	310 W

Vibrations	
Sanding of surfaces	5.5 m/s <sup>2</sup>
Uncertainty of the measurement K	1.5 m/s <sup>2</sup>
Polishing	8.2 m/s <sup>2</sup>
Uncertainty of the measurement K	1.5 m/s <sup>2</sup>
Acoustic emissions	
Sound pressure level	80 dB(A)
Sound power level	91 dB(A)
Uncertainty of the measurement K	3 dB(A)

## Orbital sander 92 x 184 mm – 210W



- Powerful and easy to handle, orbital sander with drilled plate with a velcro attachment or with 92 x 184 mm retaining clips. Equipped with electronic speed adjustment and speed maintained when under load.
  - Indicated for processing untreated and painted metals, wood and plastics. Work processing in carpentry shops, body shops, preparation for painting and the removal of old paints, etc.
  - Softgrip slip-resistant handgrip even for hand processing, work processing with less vibration, thanks to the well-balanced mechanism. Robust aluminium plate with a velcro surface and lateral clips for utilising with classical sand paper.
  - Easy to empty fabric dust bag to work without vacuum extraction, or the possibility of a vacuum extractor thanks to the connection to a universal extractor.
  - Supplied as standard: fabric dust bag. Supplied in a plastic case.
- P { margin-bottom: 0.21cm; }

9

Code	Desc.
4170040080	SRE3185

Spare Parts		
Article	Code	Desc.
Spare parts - pair of brushes	417RC16490	1259
Drilled plate 92 x 184 mm	417RC16520	1262
Fabric dust bag	417RC16510	1261

Technical Features	
Cable length	4 m
Weight without cable	1,5 Kg
Orbit diameter	2 mm
Plate dimensions	92 x 184 mm
Max. Power	210 W
Max. oscillations	8.800 – 22.300 /minute

Vibrations	
Sanding of surfaces	4 m/s <sup>2</sup>
Uncertainty of the measurement K	1.5 m/s <sup>2</sup>
Acoustic emissions	
Sound pressure level	73 dB(A)
Sound power level	84 dB(A)
Uncertainty of the measurement K	3 dB(A)

## 175 mm electronic polisher – 1200W



- Small, but powerful rotary polisher equipped with electronic speed adjustment and preset speed maintained when under load. Useful for polishing and sanding all types of surfaces.
- Indicated for polishing vehicle paintwork, stone and marble, for sanding paints and all types of untreated surfaces in the carpentry and metalwork sector.
- Extremely compact machine body that can be easily handled, with ergonomic slip-resistant front handgrip. Supplementary lateral handgrip can be mounted.
- High torque mechanism with double gear reduction transmission for microfinishing and mirror polishing surfaces. Full wave Vario-Tacho-Constamatic (VTC) electronics with a rotating knob to work at speeds that remain constant even under load and adequate for the materials being processed.
- Electronic protection against overloads, slow start to avoid recoil, anti-restart protection if the power supply fails. Motor equipped with self-releasing brushes to protect the armature.
- Supplied as standard: hand protection, supplementary lateral handgrip. Supplied without pad.

Code	Desc.
4170040090	PE12-175

Spare Parts		
Article	Code	Desc.
Spare parts - pair of brushes	417RC16530	1263
Supplementary handgrip	417RC16330	1243
147 mm diameter pad	3420102160	71

Technical Features	
Cable length	4 m
Weight without cable	2,4 Kg
Shaft threading	M 14
Max. revolutions when idling No.	700-2.200/minute
Max torque	14 Nm
Max. pad diameter	175 mm
Max. Power	1.200 W

Vibrations	
Polishing	5 m/s <sup>2</sup>
Uncertainty of the measurement K	2.5 m/s <sup>2</sup>
Acoustic emissions	
Sound pressure level	85 dB(A)
Sound power level	96 dB(A)
Uncertainty of the measurement K	3 dB(A)



## Reversible rotating drill 650W – 1.5/13 mm



- Compact, high performance reversible rotating drill with electronic speed adjustment that can drill up to 13 mm diameter holes in steel.
- Indicated for all types of jobs in all sectors. Any type of bit can be used with a cylindrical attachment and the adjustable speed permits the drill to be used for any type of work processing. The reversibility allows the drill to be used for small screwing/unscrewing jobs.
- Slip-resistant Softgrip handgrip, rack and pinion mandrel with jaws that open from 1.5 mm to 13 mm, speed adjustment wheel on the ON button and its locking button.
- Removing the mandrel, the shaft displays a ¼" hexagonal shank for the direct mounting of screw bits.
- Supplied as standard: 1.5/13 mm rack and pinion mandrel with a mandrel key. Supplied in a cardboard box.

9

Code	Desc.
4170040100	BE650

Spare Parts			
Article	Code	Desc.	
Spare parts - pair of brushes	417RC16550	1265	
1.5/13 mm rack and pinion mandrel	417RC00130	4-1,5/13	
Rack and pinion mandrel key	421RC00650	221378	
1.5/13 mm plastic self-tightening mandrel	417RC00090	2-1,5/13	
1.5/13 mm metal self-tightening mandrel	417RC00110	3-1,5/13	

Technical Features	
Max. Power	650 W
Ø max. hole in steel (mm)	13
Ø max hole in wood (mm)	30
Cable length	2,55 m
Weight without cable	1,8 Kg
Shaft threading	1/2" x 20 UNF
Spindle opening	1,5/13 mm
Collar diameter	43 mm
Max. revolution No.	0-2.800/minute

Vibrations	
Metal drilling	4.8 m/s <sup>2</sup>
Uncertainty of the measurement K	1.5 m/s <sup>2</sup>
Acoustic emissions	
Sound pressure level	85 dB(A)
Sound power level	96 dB(A)
Uncertainty of the measurement K	3 dB(A)

## Dual-speed reversible rotating drill 850W – 1.5/13 mm



- Compact, high performance reversible rotating drill with electronic adjustment of speed and dual mechanical speed, that can drill up to 13 mm diameter holes in steel.
- Indicated for all types of jobs in all sectors. Any type of bit can be used with a cylindrical attachment and the adjustable speed permits the drill to be used for any type of work processing. The reversibility allows the drill to be used for small screwing/unscrewing jobs.
- Slip-resistant Softgrip handgrip, rack and pinion mandrel with jaws that open from 1.5 mm to 13 mm, speed adjustment wheel on the ON button and its locking button, switch for 1st speed and high torque or 2nd speed and low torque.
- Mechanical safety clutch for the highest safety at work, powerful motor with high resistance to overload.
- Removing the mandrel, the shaft displays a ¼" hexagonal shank for the direct mounting of screw bits.
- Supplied as standard: 1.5/13 mm rack and pinion mandrel, supplementary handgrip. Supplied in a cardboard box.

Code	Desc.
4170040110	BE850-2

Spare Parts		
Article	Code	Desc.
Spare parts - pair of brushes	417RC16560	1266
1.5/13 mm rack and pinion mandrel	417RC00130	4-1,5/13
Mandrel key	421RC00650	221378
1.5/13 mm plastic self-tightening mandrel	417RC00090	2-1,5/13
1.5/13 mm metal self-tightening mandrel	417RC00110	3-1,5/13

Technical Features	
Cable length	4 m
Weight without cable	2,8 Kg
Shaft threading	1/2" x 20 UNF
Spindle opening	1,5/13 mm
Collar diameter	43 mm
Mechanical speed No.	2
Max. revolution No.	0-1.100 – 0-3.400/minute
Max. Power	850 W
Maximum torque	36/14 Nm
Ø max hole in wood (mm)	40/25
Ø max. hole in steel (mm)	13/8

Vibrations	
Metal drilling	4 m/s <sup>2</sup>
Uncertainty of the measurement K	1.5 m/s <sup>2</sup>
Acoustic emissions	
Sound pressure level	100 dB(A)
Sound power level	111 dB(A)
Uncertainty of the measurement K	3 dB(A)

# Reversible rotating core drill 1,100W



- Extra powerful reversible rotating core drill equipped with mechanical dual-speed adjustment designed to drill large diameter holes and for utilisation as a mixer for dense liquid materials.
- Indicated for drilling jobs even on hard and very thick steel and wood, dry crown coring of masonry and for mixing paints and mortar.
- Robust, die-cast aluminium gearhead for the maximum heat dissipation and long life, Vario electronics to work at an adequate speed on materials, mechanical dual speed for low speed and high torque or high speed and low torque.
- Mechanical safety clutch for the highest safety at work, powerful motor with high resistance to overload.
- Supplied as standard: 3/16 mm rack and pinion mandrel with supplementary handgrip with a depth rod. Supplied in a cardboard box.

Code	Desc.
4170040120	BDE1100

Spare Parts		
Article	Code	Desc.
Spare parts - pair of brushes	417RC16570	1267
3/16 mm rack and pinion mandrel	417RC00140	4-3/16
Mandrel key	417RC00170	5-3/16

Technical Features	
Cable length	3 m
Weight without cable	4,3 Kg
Shaft threading	5/8" x 16 UNF
Spindle opening	3/16 mm
Collar diameter	43 mm
Maximum torque	55/22 Nm
Max. Power	1.100 W
Ø max. hole in steel (mm)	16/10
Ø max hole in wood (mm)	40/25
Mechanical speed No.	2
Max. revolutions when idling No.	0-640/0-1.200/minute

Vibrations	
Metal drilling	4 m/s <sup>2</sup>
Uncertainty of the measurement K	1.5 m/s <sup>2</sup>
Acoustic emissions	
Sound pressure level	85 dB(A)
Sound power level	96 dB(A)
Uncertainty of the measurement K	3 dB(A)

## Reversible hammer drill 1,010W



- Powerful reversible hammer drill equipped with mechanical dual-speed adjustment and electronic speed adjustment to maintain the speed even under load and reversibility.
- Indicated for drilling jobs even on hard and very thick steel and wood, for hammer drilling on building materials and for screwing/unscrewing operations. Removing the mandrel, the shaft displays a 1/4" hexagonal shank for the direct mounting of screw bits.
- Vario-Tacho-Constamatic (VTC) full wave electronics to adjust the speed constantly for the materials being drilled. Robust, die-cast aluminium gearhead for the maximum heat dissipation and long life. Rotating brush holder for maximum power even when rotating anticlockwise; e.g., to easily unscrew even blocked screws.
- Metabo Marathon motor dust-resistant protection for long life. Metabo S-automatic safety clutch: mechanical release of the transmission when the tool being utilised becomes blocked and to work in complete safety.
- Supplied as standard: 1.5/13 mm self-tightening mandrel with supplementary vibration-resistant handgrip with a depth rod. Supplied in a plastic case.

Code	Desc.
4170040130	SBEV1000-2

Spare Parts			
Article	Code	Desc.	
Spare parts - pair of brushes	417RC16580	1268	
1.5/13 mm self-tightening mandrel	417RC00110	3-1,5/13	
Supplementary handgrip	417RC16590	1269	

Technical Features	
Weight without cable	2,7 Kg
Shaft threading	1/2" x 20 UNF
Collar diameter	43 mm
Spindle opening	1,5/13 mm
Mechanical speed No.	2
Max. No. of impacts	53.200/minute
Max. revolutions when idling No.	0-1.000/0-2800/minute
Ø max hole in wood (mm)	40/25
Ø max hole in masonry (mm)	22
Max. Ø hole in concrete (mm)	20
Ø max. hole in steel (mm)	16/10
Max. Power	1.010 W
Maximum torque	40/14 Nm

Vibrations	
Metal drilling	4.2 m/s <sup>2</sup>
Uncertainty of the measurement K	1.5 m/s <sup>2</sup>
Hammer drilling in reinforced concrete	17 m/s <sup>2</sup>
Uncertainty of the measurement	1.5 m/s <sup>2</sup>
Acoustic emissions	
Sound pressure level	103 dB(A)
Sound power level	114 dB(A)
Uncertainty of the measurement K	3 dB(A)



## 1/2" impact screwdriver – 600 Nm



- High-power, light, and compact screwdriver, which can be used for heavy duty, even continuous, of assembly of screws and bolts in each processing sector.
- Indicated for mechanical workshops, metalwork, woodwork, servicemen, assembly lines, etc.
- Current power supply 220 V - 50 Hz Supplied with a 5 m long power cable, speed adjustment by means of the ON button, reversibility, 1/2" tool cabinet attachment.
- Very strong structure with motor body in shock-resistant material and aluminium impact gearhead for the highest lightness and the optimal heat dissipation. Central handgrip for an optimal balancing during use.
- Supplied in a cardboard box.

Code	Desc.
4170040230	SSW650

Technical Features	
Weight without cable	3 Kg
Power supply cable length (m)	5 m
Square connection	1/2"
Max. No. of impacts	2800/minute
Maximum torque	600 Nm
Max. revolution No.	0 – 2100/minute
Power feed	220 V – 50 Hz
Power output	650 W

Vibrazioni	
Avvitatura a percussione	12 m/s <sup>2</sup>
Insicurezza di misurazione K	1,5 m/s <sup>2</sup>
Emissioni acustiche	
Livello di pressione acustica	98 dB(A)
Livello di potenza sonora	109 dB(A)
Incertezza della misurazione K	3 dB(A)

## SDS-Plus wall plug drill 800W – 2.3 Joules



- Compact and handy SDS-Plus wall plug drill with rapid bit and scalpel attachment suitable for drilling in reinforced concrete, masonry and light chiselling of plaster and finishes.
- Indicated for all drilling jobs of building materials, fixing of objects, drilling for anchorage fixings, removal of plaster and tiles and small chasing jobs, etc.
- Reversible, equipped with electronic speed adjustment. Suitable for hammer drilling, normal drilling and chiselling without rotation.
- Vario electronics to operate at the correct speed for various materials. Metabo S-automatic safety clutch: mechanical release of the transmission when the tool being utilised becomes blocked and to work in complete safety. Switch can be locked in position to work comfortably if the job being carried out is a long one.
- Supplied as standard: Supplementary handgrip with a depth rod. Supplied in a plastic case.

Code	Desc.
4170040140	KHE2444

Spare Parts		
Article	Code	Desc.
Spare parts - pair of brushes	417RC16600	1270
Supplementary handgrip	417RC16610	1271

Technical Features	
Cable length	4 m
Weight without cable	2,4 Kg
Collar diameter	43 mm
Rapid tool attachment	SDS-Plus
Ø max hole in wood (mm)	30
Max. revolution No.	0-1.230/minute
Maximum torque	15 Nm
Max. energy per single strike	2,3 Joule
Max. No. of impacts	5.400/minute
Max. hole Ø in reinforced concrete with full bits	24 mm
Ø max. hole in steel (mm)	13
Max. hole Ø in reinforced concrete with crown bits	68 mm
Max. Power	800 W

Vibrations	
Hammer drilling in reinforced concrete	13.7 m/s <sup>2</sup>
Uncertainty of the measurement K	1.5 m/s <sup>2</sup>
Chiselling	15 m/s <sup>2</sup>
Uncertainty of the measurement	1.5 m/s <sup>2</sup>
Acoustic emissions	
Sound pressure level	87 dB(A)
Sound power level	98 dB(A)
Uncertainty of the measurement K	3 dB(A)

## SDS-Plus wall plug drill 850W – 3 Joule



- Wall plug drill with double mandrel: SDS-Plus rapid attachment and 13 mm max. self-tightening mandrel, suitable for drilling in reinforced concrete, masonry and light chiselling of plaster and finishes.
- Indicated for all drilling jobs of building materials, fixing of objects, drilling for anchorage fixings, removal of plaster and tiles and small chasing jobs, etc.
- Reversible, equipped with electronic speed adjustment. Suitable for hammer drilling, normal drilling and chiselling without rotation.
- Metabo Quick: rapid substitution between mandrel and SDS-Plus hammer bit and self-tightening mandrel for drilling in wood and in metal. Vario electronics to operate at the correct speed for various materials. Metabo S-automatic safety clutch: mechanical release of the transmission when the tool being utilised becomes blocked and to work in complete safety. Switch can be locked in position to work comfortably if the job being carried out is a long one.
- High performance hammer action precisely mounted in an aluminium alloy housing: long lasting and robust
- Supplied as standard: Quick release double mandrel and supplementary vibration-resistant handgrip with depth rod. Supplied in a plastic case.

9

Code	Desc.
4170040150	KHE2660Q

Spare Parts			
Article	Code	Desc.	
Spare parts - pair of brushes	417RC16620	1272	
SDS-Plus mandrel spare part	417RC16630	1273	
1.5/13 self-tightening mandrel spare part	417RC16640	1274	
Supplementary handgrip	417RC16650	1275	

Technical Features	
Cable length	4 m
Weight without cable	3,1 Kg
Self-tightening mandrel opening	1,5/13 mm
Collar diameter	50 mm
Rapid tool attachment	SDS-Plus
Ø max hole in wood (mm)	32
Max. revolution No.	0-1.100/minute
Maximum torque	18 Nm
Max. hole Ø in reinforced concrete with full bits	26 mm
Max. hole Ø in reinforced concrete with crown bits	68 mm
Ø max. hole in steel (mm)	13
Max. energy per single strike	3 Joule
Max. No. of impacts	4.300/minute
Max. Power	850 W

Vibrations	
Hammer drilling in reinforced concrete	12.9 m/s <sup>2</sup>
Uncertainty of the measurement K	2.4 m/s <sup>2</sup>
Chiselling	8.5 m/s <sup>2</sup>
Uncertainty of the measurement	1.5 m/s <sup>2</sup>
Acoustic emissions	
Sound pressure level	89 dB(A)
Sound power level	99 dB(A)
Uncertainty of the measurement K	3 dB(A)



## SDS-Plus combined drill 800W – 3.1 Joules



- Combination drill with double mandrel: SDS-Plus rapid attachment and 13 mm max. self-tightening mandrel, suitable for drilling in reinforced concrete, masonry and light chiselling of plaster and finishes.
- Indicated for all drilling jobs of building materials, fixing of objects, drilling for anchorage fixings, removal of plaster and tiles and small chasing jobs, etc.
- Reversible, equipped with electronic speed adjustment. Suitable for hammer drilling, normal drilling and chiselling without rotation.
- Metabo VibraTech (MVT): integrated damping system and supplementary handle to reduce vibrations in order to protect the user's health Ergonomic housing shape for chiselling tasks without supplementary handle Vario electronics to operate at the correct speed for various materials. Metabo Marathon motor dust-resistant protection for long life.
- High performance hammer action precisely mounted in an aluminium alloy housing: long lasting and robust Metabo S-automatic safety clutch: mechanical release of the transmission when the tool being utilised becomes blocked and to work in complete safety. Cable-protecting ball joint for optimal freedom of motion when working
- Supplied as standard: Quick release double mandrel and supplementary vibration-resistant handgrip with depth rod. Supplied in a plastic case.

Code	Desc.
4170040160	KHE3251

Spare Parts			
Article	Code	Desc.	
Spare parts - pair of brushes	417RC16660	1276	
SDS-Plus mandrel spare part	417RC16635	1273	
1.5/13 self-tightening mandrel spare part	417RC16640	1274	
Supplementary handgrip	417RC16670	1277	

Technical Features	
Cable length	4 m
Weight without cable	3,6 Kg
Self-tightening mandrel opening	1,5/13 mm
Collar diameter	50 mm
Rapid tool attachment	SDS-Plus
Maximum torque	20 Nm
Max. revolution No.	0-1.150/minute
Ø max hole in wood (mm)	35
Ø max. hole in steel (mm)	13
Max. Power	800 W
Max. energy per single strike	3,1 Joule
Max. No. of impacts	4.470/minute
Max. hole Ø in reinforced concrete with crown bits	82 mm
Max. hole Ø in reinforced concrete with full bits	32 mm

Vibrations	
Hammer drilling in reinforced concrete	12.9 m/s <sup>2</sup>
Uncertainty of the measurement K	1.5 m/s <sup>2</sup>
Chiselling	10.9 m/s <sup>2</sup>
Uncertainty of the measurement	1.5 m/s <sup>2</sup>
Acoustic emissions	
Sound pressure level	91 dB(A)
Sound power level	102 dB(A)
Uncertainty of the measurement K	3 dB(A)



## SDS-Max combined drill 1100W – 8.5 Joules



- Combination drill with rapid attachment of SDS-Max tools, suitable for drilling in reinforced concrete, masonry, light chiselling of plaster and finishes, and light demolitions.
- Indicated for all drilling jobs of building materials, fixing of objects, drilling for anchorage fixings, removal of plaster and tiles, chasing jobs, demolitions, etc.
- Ergonomic housing shape for chiselling tasks also without supplementary handle. Optimal heat dissipation and weight reduction via the die-cast magnesium gearhead. Metabo S-automatic safety clutch: mechanical release of the transmission when the tool being utilised becomes blocked and to work in complete safety.
- Supplied as standard: supplementary rubberised handgrip, depth rod, tool lubricant. Supplied in plastic case.

Code	Desc.
4170040340	KH 5-40

Tecnical Features	
Cable length	4 m
Weight without cable	7,1 Kg
Collar diameter	61 mm
Rapid tool attachment	SDS-Max
Max. hole Ø in reinforced concrete with crown bits	105 mm
Max. revolution No.	620/minutes
Max. hole Ø in reinforced concrete with full bits	40 mm
Max. Power	110 W
Max. No. of impacts	2800/minutes
Max. energy per single strike	8,5 joule

Vibrazioni	
Foratura a martello su calcestruzzo	16,5 m/s <sup>2</sup>
Insicurezza della misurazione K	1,5 m/s <sup>2</sup>
Scalpellatura	13,3 m/s <sup>2</sup>
Insicurezza della misurazione K	1,5 m/s <sup>2</sup>
Emissioni acustiche	
Livello di pressione acustica	96 dB (A)
Livello di potenza sonora	106 dB(A)
Insicurezza della misurazione K	3 dB(A)

## SDS-Max combined drill 1300W – 8.5 Joules



- Combination drill with rapid attachment of SDS-Max tools, suitable for drilling in reinforced concrete, masonry, light chiselling of plaster and finishes, and light demolitions.
- Indicated for all drilling jobs of building materials, fixing of objects, drilling for anchorage fixings, removal of plaster and tiles, chasing jobs, demolitions, etc.
- Metabo VibraTech (MVT): integrated damping system and supplementary handle to reduce vibrations in order to protect the user's health Ergonomic housing shape for chiselling tasks without supplementary handle Vario-Tacho-Constamatic (VTC) electronics to operate at the correct speed for various materials.
- Selector for the optional 30% reduction of strikes to work with softer materials. Electronic soft start to start drilling with precision.
- Optimal heat dissipation and weight reduction via the die-cast magnesium gearhead. Metabo S-automatic safety clutch: mechanical release of the transmission when the tool being utilised becomes blocked and to work in complete safety. Service indicator: e.g., immediately before the substitution of the brushes; there is also a luminous warning light that advises that the power supply is on. Switch can be locked in position to work comfortably if the job being carried out is a long one.
- Supplied as standard: supplementary vibration-resistant handgrip, depth rod, tool lubricant, cleaning cloth. Supplied in a plastic case.

Code	Desc.
4170040170	KHE56

Spare Parts		
Article	Code	Desc.
Spare parts - pair of brushes	417RC16680	1278
Supplementary handgrip	417RC16690	1279

Technical Features	
Cable length	6 m
Weight without cable	6,7 Kg
Collar diameter	66 mm
Rapid tool attachment	SDS-Max
Maximum torque	90 Nm
Max. No. of impacts	2.840/minute
Max. hole Ø in reinforced concrete with full bits	45 mm
Max. revolution No.	0-300/minute
Max. Power	1.300 W
Max. energy per single strike	8,5 Joule

Vibrations	
Hammer drilling in reinforced concrete	11.5 m/s <sup>2</sup>
Uncertainty of the measurement K	1.5 m/s <sup>2</sup>
Chiselling	9.7 m/s <sup>2</sup>
Uncertainty of the measurement	2.4 m/s <sup>2</sup>
Acoustic emissions	
Sound pressure level	96 dB(A)
Sound power level	107 dB(A)
Uncertainty of the measurement K	3 dB(A)

## SDS-Max combined drill 1500W – 11.9 Joules



- Combination drill with rapid attachment of SDS-Max tools, suitable for drilling in reinforced concrete, masonry, light chiselling of plaster and finishes, and medium demolitions.
- Indicated for all drilling jobs of building materials, fixing of objects, drilling for anchorage fixings, removal of plaster and tiles, chasing jobs, demolitions, etc.
- Metabo VibraTech (MVT): integrated damping system and supplementary handle to reduce vibrations in order to protect the user's health Ergonomic housing shape. Vario-Tacho-Constamatic (VTC) electronics to operate at the correct speed for various materials.
- Selector for the optional 30% reduction of strikes to work with softer materials. Electronic soft start to start drilling with precision.
- Optimal heat dissipation and weight reduction via the die-cast magnesium gearhead. Metabo S-automatic safety clutch: mechanical release of the transmission when the tool being utilised becomes blocked and to work in complete safety. Service indicator: e.g., immediately before the substitution of the brushes; there is also a luminous warning light that advises that the power supply is on. Switch can be locked in position to work comfortably if the job being carried out is a long one.
- Supplied as standard: supplementary vibration-resistant handgrip, depth rod, tool lubricant, cleaning cloth. Supplied in a plastic case.

9

Code	Desc.
4170040000	KHE76

Spare Parts		
Article	Code	Desc.
Spare parts - pair of brushes	417RC16700	1280
Supplementary handgrip	417RC16710	1281

Technical Features	
Cable length	6 m
Weight without cable	8,4 Kg
Collar diameter	66 mm
Rapid tool attachment	SDS-Max
Maximum torque	100 Nm
Max. revolution No.	0-300/minute
Max. Power	1.500 W
Max. hole Ø in reinforced concrete with full bits	50 mm
Max. No. of impacts	2.735/minute
Max. energy per single strike	11,9 Joule

Vibrations	
Hammer drilling in reinforced concrete	9.7 m/s <sup>2</sup>
Uncertainty of the measurement K	1.5 m/s <sup>2</sup>
Chiselling	9.7 m/s <sup>2</sup>
Uncertainty of the measurement	1.5 m/s <sup>2</sup>
Acoustic emissions	
Sound pressure level	96 dB(A)
Sound power level	107 dB(A)
Uncertainty of the measurement K	3 dB(A)

## Multiuse electronic tool MT400Q



- Multiuse electronic tool for sawing, sanding, scraping and removing paint and protective materials, thanks to the variety of accessories that can be mounted.
- Indicated for all types of work sectors: metal, wood, resin, fibre, ceramic finishes, plasterboard, plastering, etc.
- A vast range of accessories is available that are compatible with electro-tools of other makes that have the OIOS attachment, Starlock, etc. Rapid change of the tools without the utilisation of equipment, dual LEDs for anterior illumination of the work zone, slip-resistant handgrip, possibility of dust removal via connection to a vacuum cleaner.
- Oscillation angle of 3.2° for fast action, electronic oscillation speed setting to adapt to different materials, maintenance of oscillation speed under load by electronic control.
- Supplied as standard: 93 mm triangular, drilled, Velcro plate, 32 mm blade for cutting wood, adaptors for vacuum cleaners and multiple adaptors for accessories. Supplied in a cardboard box.

Code	Desc.
4170040260	MT400Q

Technical Features	
Weight without cable	1,4 Kg
Max. oscillation number	11000 - 18500/min
Velcro drilled plate	93 mm
Oscillation angle	3,2°
Max. Power	400 W

Vibrations	
Sanding of surfaces	5 m/s <sup>2</sup>
Uncertainty of the measurement K	1.5 m/s <sup>2</sup>
Scraping	3.7 m/s <sup>2</sup>
Uncertainty of the measurement K	1.5 m/s <sup>2</sup>
Immersed blade cutting	6.1 m/s <sup>2</sup>
Cutting with segment blade	4.6 m/s <sup>2</sup>
Uncertainty of the measurement K	1.5 m/s <sup>2</sup>
Acoustic emissions	
Sound pressure level	83 dB(A)
Sound power level	94 dB(A)
Uncertainty of the measurement K	3 dB(A)



## Triangular, drilled, Velcro plate for the multiuse electric tool MT400Q

- Spare part triangular plate for utilisation with triangular, abrasive Velcro sheets with holes for the removal of the dust. Measurement from corner to corner: 93 mm. Starlock rapid attachment.



Code	Desc.
417RC17200	1324

## Set of accessories for restorations for the multiuse electric tool MT400Q

- Set for internal restorations, for work on floors and assembling, such as the reshaping of laminate/parquet, cutting to measure of door frames on floors, plunge cuts in finished panels, wood, cavity cutting in pieces of furniture
- Set composed of: 1 x 32 mm HCS immersion blade (wood), 1 x 85 mm segment blade BiM (wood + metal), 1 x 52 mm rigid scraper HCS, 1 x 32 mm immersion blade BiM (metal)



Code	Desc.
417RC17210	1325

## Set of accessories for tilers for the multiuse electric tool MT400Q

- Set for tilers, various restoration works and modifications, such as the removal of tile mortar or tile glue, milling of grout lines on wall and floor tiles, milling of small refinishings on soft wall tiles.
- Set composed of: 1 x 85 mm segment blade HM (tiles), 1 x 78 mm triangular sanding plate HM (tiles), 1 x 52 mm rigid scraper HCS, 1 x 32 mm immersion blade BiM (metal).



Code	Desc.
417RC17220	1326

## Triangular, Velcro, drilled Corundum sheets for the multiuse electric tool MT400Q



- Quality abrasive sheets with half-opened dissipation and high machining yield for a homogeneous sanded result.
- For veneering, solid wood, polyester, steel and stainless steel sheets, non-ferrous metals, light metals.
- For sanding veneered doors of wardrobes and side parts, for sanding laminate furniture with hot-glued edges, for decorative sanding of stainless steel sheets, for refinishing and removals of burrs from sheets cut to measure.

Code	Desc.	Grain
417RC17230	1327	P 40
417RC17240	1328	P 80
417RC17250	1329	P 100
417RC17260	1330	P 120
417RC17270	1331	P 180
417RC17280	1332	P 240
417RC17290	1333	P 320

## Top, triangular, drilled, Velcro sheets for the multiuse electric tool MT400Q



- Quality abrasive sheets with half-opened dissipation and high machining yield
- For working on details of paint, lacquers of all types and stucco.
- For chamfering and cleaning up compensates, veneered wood, solid wood, painted surfaces and for chamfering the edges of veneered furniture.

Code	Desc.	Grain
417RC17300	1334	P 40
417RC17310	1335	P 60
417RC17320	1336	P 80
417RC17330	1337	P 100
417RC17340	1338	P 120
417RC17350	1339	P 180
417RC17360	1340	P 240
417RC17370	1341	P 320

## Blades for multipurpose tools with Starlock attachment

- Vast assortment of blades compatible with the majority of Multitool tools on sale, with Starlock attachment, recommended for working all types of material. A range of lengths, widths and tooth sizes means you always have the right tool for every need.
- **CAUTION:** Always make sure that the machine has a Starlock coupling as other types (Starlock Plus – Starlock Max) are not compatible with these tools.

### Plunge cutting blade for wood (32 x 45 mm)



- HCS blade for clean cuts on soft wood, including plunge cuts. Convex teeth for cleaner, easier cuts.
- Graded scale engraved by laser on the body of the blade to check the depth of cut while machining.

Code	Desc.
417RC17430	1347

Technical Features	
Larghezza	32 mm
Dentatura	1,3 mm/20 TPI
Idoneità materiale	Soft wood
Tipo di attacco	Starlock
Materiale lama	HCS
Lunghezza	45 mm

### Plunge cutting blade for hard wood (32 x 45 mm)



- HCS blade for clean cuts on hard wood and panels with laminate base, including plunge cuts. Convex teeth for cleaner, easier cuts.
- Graded scale engraved by laser on the body of the blade to check the depth of cut while machining.

Code	Desc.
417RC17440	1348

Technical Features	
Dentatura	1,8 mm/14 TPI
Materiale lama	HCS
Lunghezza	45 mm
Larghezza	32 mm
Idoneità materiale	Hard wood laminates
Tipo di attacco	Starlock

## Plunge cutting blade for wood/metal (20 x 30 mm)



- Bimetallic blade for clean cuts on soft wood, hard wood, wood with nails, panels faced with plastics, including plunge cuts. Bimetallic teeth for excellent durability and cutting quality.
- Graded scale engraved by laser on the body of the blade to check the depth of cut while machining.

Code	Desc.
417RC17450	1349

Technical Features	
Materiale lama	BiM
Lunghezza	30 mm
Dentatura	1,3 mm/20 TPI
Larghezza	20 mm
Idoneità materiale	Soft wood Hard wood Wood with nails Faced panels Plastics
Tipo di attacco	Starlock

## Plunge cutting blade for wood/metal 32 x 45 mm



- Bimetallic blade for clean cuts on soft wood, hard wood, wood with nails, panels faced with plastics, including plunge cuts. Bimetallic teeth for excellent durability and cutting quality.
- Graded scale engraved by laser on the body of the blade to check the depth of cut while machining.

Code	Desc.
417RC17460	1350

Technical Features	
Materiale lama	BiM
Lunghezza	45 mm
Dentatura	1,3 mm/20 TPI
Larghezza	32 mm
Idoneità materiale	Soft wood Hard wood Wood with nails Faced panels Plastics
Tipo di attacco	Starlock

## Plunge cutting blade for wood/metal 65 x 35 mm



- Bimetallic blade for clean cuts on soft wood, hard wood, wood with nails, panels faced with plastics, including plunge cuts. Bimetallic teeth for excellent durability and cutting quality.
- Graded scale engraved by laser on the body of the blade to check the depth of cut while machining.

Code	Desc.
417RC17470	1351

Technical Features	
Idoneità materiale	Soft wood Hard wood Wood with nails Faced panels Plastics
Dentatura	1,3 mm/20 TPI
Lunghezza	35 mm
Larghezza	65 mm
Materiale lama	BiM
Tipo di attacco	Starlock



## Segmented blade for wood/metal Ø 85 mm

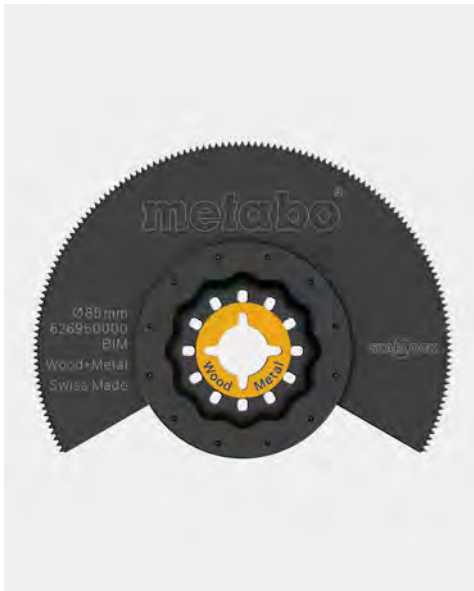

- Bimetallic blade for clean cuts on soft wood, hard wood, wood with nails, panels faced with plastics, including plunge cuts. Bimetallic teeth for excellent durability and cutting quality.

Code	Desc.
417RC17480	1352

Tecnical Features	
Idoneità materiale	Soft wood Hard wood Wood with nails Faced panels Plastics
Dentatura	1,3 mm/20 TPI
Materiale lama	BiM
Blade diameter mm	85 mm
Tipo di attacco	Starlock

## Plunge cutting blade for metal 32 x 45 mm



- Bi-metallic blade for clean cuts on light alloy profiles such as copper or aluminium, including plunge cutting. Bi-metallic teeth for excellent durability and cutting quality.
- Graded scale engraved by laser on the body of the blade to check the depth of cut while machining.

Code	Desc.
417RC17490	1353

Tecnical Features	
Dentatura	1,3 mm/20 TPI
Lunghezza	45 mm
Larghezza	32 mm
Materiale lama	BiM
Tipo di attacco	Starlock
Idoneità materiale	Copper profiles Aluminium profiles

## Plunge cutting blade for steel 32 x 35 mm



- Hartmetal blade that is ideal for clean cuts on all types of metal, iron, steel and stainless steel, including plunge cuts. Hard metal teeth for excellent durability and cutting quality.
- Graded scale engraved by laser on the body of the blade to check the depth of cut while machining.

Code	Desc.
417RC17500	1354

Tecnical Features	
Dentatura	1,3 mm/20 TPI
Larghezza	32 mm
Idoneità materiale	Metal Steel Stainless steel
Tipo di attacco	Starlock
Lunghezza	35 mm
Materiale lama	HM

## HCS scraper (52 mm)



- HCS blade width 52 mm, to remove paint, coverings, tongue and groove, fitted carpet, etc. Sharp, durable blade.

Code	Desc.
417RC17510	1355

Tecnical Features	
Lunghezza	25 mm
Larghezza	52 mm
Idoneità materiale	Paints Coatings Carpets
Materiale lama	HCS
Tipo di attacco	Starlock

## Segmented blade in HM for tiles and putty Ø 85 mm



- Blade with perimeter covered with Hartmetal granules (hard metal), suitable for clean cuts on tiles, building material, plaster, putty, grout widths, including plunge cuts.
- The covering on the cutting section guarantees a high degree of material removal and durable working life.

Code	Desc.
417RC17520	1356

Tecnical Features	
Dentatura	Riff 30
Idoneità materiale	Tiles Plaster Putty Building materials
Materiale lama	HM
Blade diameter mm	85 mm
Tipo di attacco	Starlock

## Triangular sanding plate in HM for building materials and putty 78 mm



- Triangular plate with 78 mm sides covered with Hartmetal granules (hard metal), suitable for sanding building material, plaster, putty, grout widths, and plasterboard.
- The covering on the plate guarantees a high degree of material removal and durable working life.

Code	Desc.
417RC17530	1357

Tecnical Features	
Materiale lama	HM
Idoneità materiale	Plaster Putty Plasterboard Building materials
Dentatura	Riff 30
Lato	78 mm
Tipo di attacco	Starlock

## Alternative electronic jigsaw 710W



- Alternative small jigsaw with a slim and compact body for the maximum handleability and ease of use. Equipped with electronic speed adjustment, pendulum movement of the blade, swarf blowing function and the possibility of mounting an extractor vacuum system.
- Indicated for all types of straight or shaped cuts on wood, compensate, metal, plastic, fibre, etc.
- Precise and material-matched sawing due to the variable stroke rate, pendulum stroke and low-lying saw blade guidance with spring support Metabo Quick system for tool-free saw blade change and with automatic ejection Selectable chip blowing function ensures free view of cutting line Vario-Tacho-Constamatic (VTC)-Full Wave Electronics for work with materials requiring customised stroke rates that remain almost constant under load
- Supplied as standard: anti-splinter plate, transparent anti-swarf protection, blade for wood, service key, inlet for vacuum extraction. Supplied in a plastic case.

9

Code	Desc.
4170040180	STE100Q

Spare Parts		
Article	Code	Desc.
Spare parts - pair of brushes	417RC16720	1282
Anti-splinter plate	417RC16730	1283

Technical Features	
Cable length	4 m
Weight without cable	2 Kg
Blade stroke (mm)	22
Number of strokes	1.000 - 3.100/minute
Max. Power	710 W
Blade pendulum movement levels	4
Max. cutting tilting	45° sx + dx
Maximum depth of the cut in steel mm	10
Max. cutting depth in non-ferrous metals (mm)	25
Maximum depth of the cut in wood (mm)	100

Vibrations	
Sawdust	13 m/s <sup>2</sup>
Shavings	13.7 m/s <sup>2</sup>
Uncertainty of the measurement	1.5 m/s <sup>2</sup>
Acoustic emissions	
Sound pressure level	86 dB(A)
Sound power level	97 dB(A)
Uncertainty of the measurement K	3 dB(A)

## 1100 W reciprocating saw



- Powerful 1,100W reciprocating saw with a tapered and ergonomic body equipped with a soft handgrip for a comfortable, easy and not tiring utilisation, ideal for cutting in all processing sectors.
- Indicated for all sectors: metalwork, cutting wood, metal, wood with nails, bodywork transformation, demolition, etc.
- Robust gearhead in die-cast aluminium and finished for an optimum grip. Metabo Quick system for tool-free saw blade change. 180° rotating blade for comfortable, overhead utilisation. Depth rod adjustable without using tools, for an optimal utilisation of the blade and various applications, such as plunge.
- Vario electronics (V) to operate at the correct number of strokes for various materials. Accelerator switch with locking function for continuous use. Gearing protected from dust and water spray.
- Supplied as standard: blade for wood and metal. Supplied in a plastic case.

Code	Desc.
4170040190	SSE1100

Spare Parts		
Article	Code	Desc.
Spare parts - pair of brushes	417RC16740	1284

Technical Features	
Cable length	4 m
Weight without cable	3,9 Kg
Blade stroke (mm)	28
Max. Power	1100
Number of strokes	0-2600

Vibrations	
Sawdust	14 m/s <sup>2</sup>
Uncertainty of the measurement	1.5 m/s <sup>2</sup>
Acoustic emissions	
Sound pressure level	89 dB(A)
Sound power level	100 dB(A)
Uncertainty of the measurement K	3 dB(A)



**Portable circular saw 1,400 W – 190 mm**

- Circular saw with 190 mm diam. Blade, maximum 66 mm cutting depth for clean and precise cutting. on most materials Powerful 1,400W motor and compact dimensions.
- Indicated for processing wood and metals: modifications, restorations, trimming, etc.
- Metabo S-automatic safety clutch: mechanical release of the transmission when the blade being utilised becomes blocked and to work in complete safety. Clearly visible cutting indicator for accurate line and curve sawing. Adjustable 0° rear position for maximum cutting precision. Lubrication system for longevity of the gearing.
- Possibility of vacuum extraction thanks to the universal extractor connection. Removal of loose shavings by the rotating extractor attachment. Self-releasing brushes to protect the motor.
- Supplied as standard: blade for cutting wood, guide for stop and parallel cuts, hexagonal service key. Supplied in a cardboard box.

9

Code	Desc.
4170040200	KS66

Spare Parts		
Article	Code	Desc.
Spare parts - pair of brushes	417RC16750	1285
Blade with 56 teeth for cutting laminates, plastics, aluminium, copper and brass at a reduced thickness	417RC16760	1286
Blade with 48 teeth for cutting soft and hard wood	417RC16770	1287
Blade with 16 teeth for cutting solid wood	417RC16780	1288

Technical Features	
Cable length	4 m
Weight without cable	5,5 Kg
Maximum torque	9 Nm
Max. revolution No.	4.200/minute
Side tilting	Da 0° a 45°
Hole blade Ø	190 x 30 mm
Max. Power	1400 W
Max. cutting depth at 45° mm.	47 mm
Max. cutting depth at 90° mm.	66 mm

Vibrations	
Chipboard sawing	2.5 m/s <sup>2</sup>
Uncertainty of the measurement	1.5 m/s <sup>2</sup>
Acoustic emissions	
Sound pressure level	95 dB(A)
Sound power level	106 dB(A)
Uncertainty of the measurement K	3 dB(A)

## 1200 W two-speed mixer



- Mixer equipped with a powerful 1,200W motor, mechanical two speeds and electronic speed adjustment, suitable for simple and easy mixing jobs of very dense and viscous materials.
- Indicated for building sector: restorations, painting, etc., or wherever it is necessary to quickly and simply mix any type of paint, mortar, glue or resin.
- Rounded edges and angles of the body for an efficient protection against injury, to replace the mixer safely and to place against the wall without slipping. The lateral exit of the cable reduces the risk of breakage. High torque thanks to the two speed transmission for viscous materials.
- Robust, die-cast aluminium gearhead for the maximum heat dissipation and long life. Accelerator switch rubber protection against dust and mud. Hermetic motor cover that protects against dirt, mud and sprays of water. Electronic soft start to avoid spraying. Vario-Tacho-Constamatic (VTC) full wave electronics to adjust the speed constantly for the materials being drilled. Speed selection knob
- Supplied as standard: 140 mm diam. paddle with mixing starting from the bottom upwards. Supplied in a cardboard box.

Code	Desc.
4170040210	RWEV1200-2

Spare Parts			
Article	Code	Desc.	
Spare parts - pair of brushes	417RC16790	1289	
140 mm diam. paddle with mixing starting from the bottom upwards of viscous materials.	417RC16800	1290	

Technical Features	
Weight without cable	4,3 Kg
Cable length	4 m
Collar diameter	43 mm
Tool connection	M 14 female
Mechanical speed No.	2
Diametro massimo delle fruste	140 mm
Recommended maximum quantity of mix	50 L
Max. Power	1200 W
Max. revolution No.	0-520/0-720/minute

Acoustic emissions	
Sound pressure level	85 dB(A)
Sound power level	96 dB(A)
Uncertainty of the measurement K	3 dB(A)

## Band saw portable inverter 220V - 1.010 W

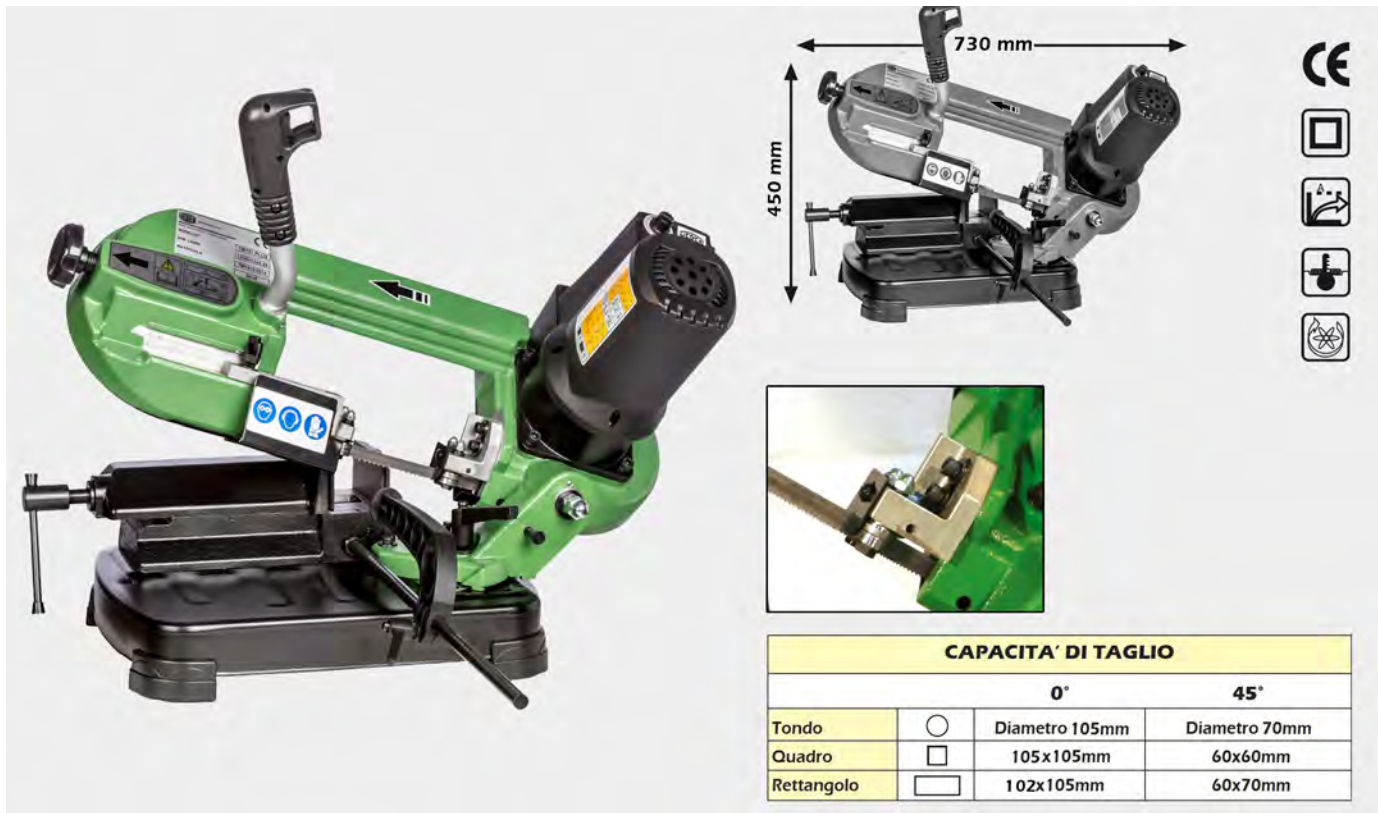

- Machine small portable dry cuts, designed for use on construction sites and in workshops.
- Ideal for working electricians, blacksmiths, tinsmiths, plumbers, carpenters, etc.
- Powerful 1000 W, single phase 230V-50Hz power supply with electronic speed control for adjusting the cutting of various materials, including stainless steel in small thicknesses.
- Cutting angle adjustable from 0 to 45 °, lock arc for easy transport, with most grip of precision steel, adjustable stop, power switch with system Antireset.

9

Code	Desc.
4170007600	TM100V

Technical Features	
Weight kg	21,5
Velocità di taglio m/min	30/80
Single-phase power supply	220V - 50 Hz
Blade dimensions mm	1.330x13x0,6
Potenza assorbita (W)	1.010
Power output HP	1,35

Spare Parts		
Article	Code	Description
Blade 1330x13x0.6 step 6/10	4950000005	1330x13x0.6-6/10
Blade 1330x13x0.6 step 8/12	4950000007	1330x13x0.6-8/12

## Band saw portable inverter 220V - 2.000 W

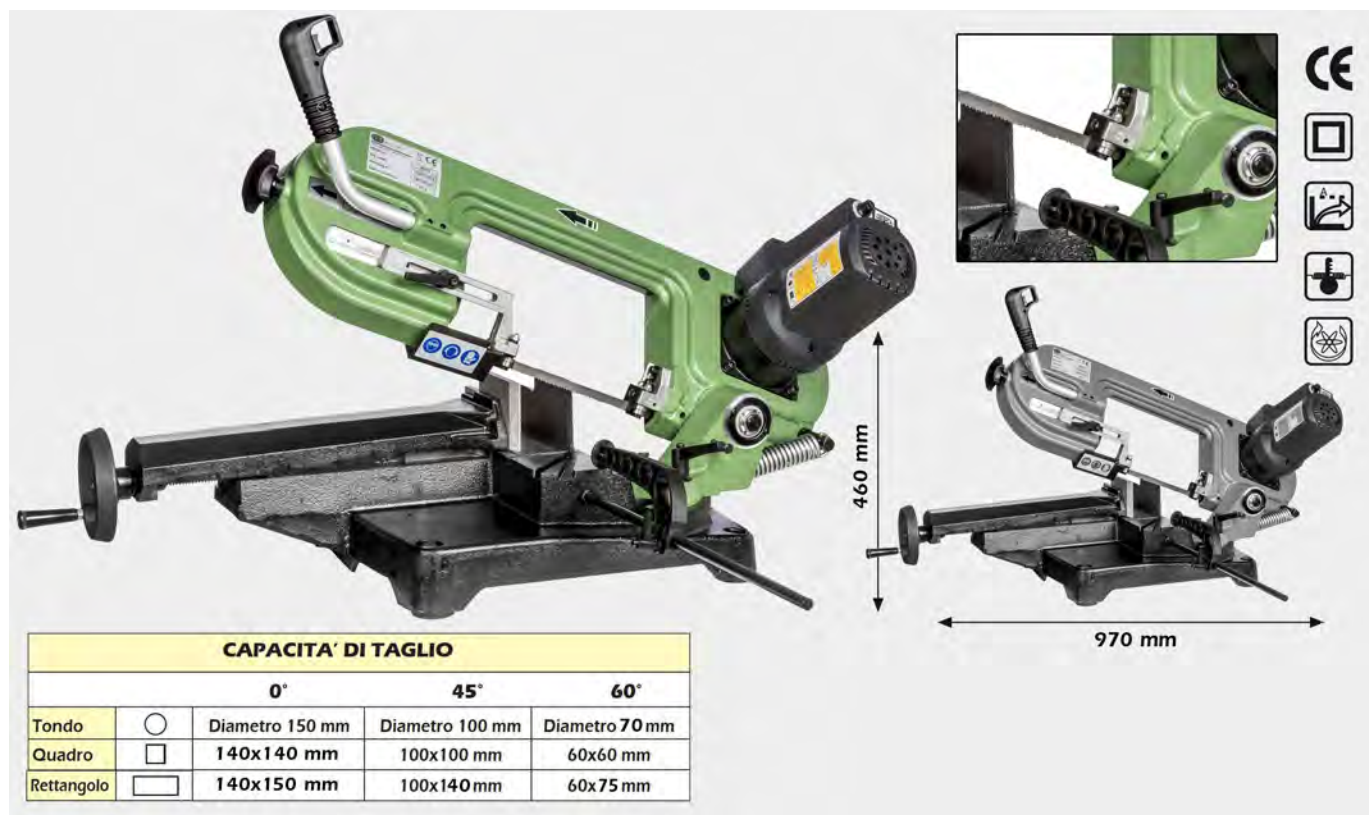

- Portable machine of average size for dry cutting, designed for use on construction sites and in workshops.
- Ideal for every type of machining, for cutting ferrous materials and plastics. Field of use vast possible thanks to the inclination of 60 °.
- Powerful 2,000 W, 230V-50Hz power supply with electronic speed control for adjusting the cutting of various materials, including stainless steel in small thicknesses.
- Cutting angle adjustable from 0 to 60 °, the locking device of the arc for easy transport, bitten accuracy with overs steel, adjustable stop, ignition switch with system Antireset.

Code	Desc.
4170007700	TM175

Technical Features	
Weight kg	64
Blade dimensions mm	1.735x13x 0,9
Potenza assorbita (W)	2.000
Velocità di taglio m/min	30/80
Single-phase power supply	220V - 50 Hz
Power output HP	2,65

Spare Parts		
Article	Code	Description
Blade 1735x13x0.9 step 6/10	4950000010	1735x13x0.6-6/10
Blade 1735x13x0.9 step 8/12	4950000015	1735x13x0.6-8/12



# Compound saw combined

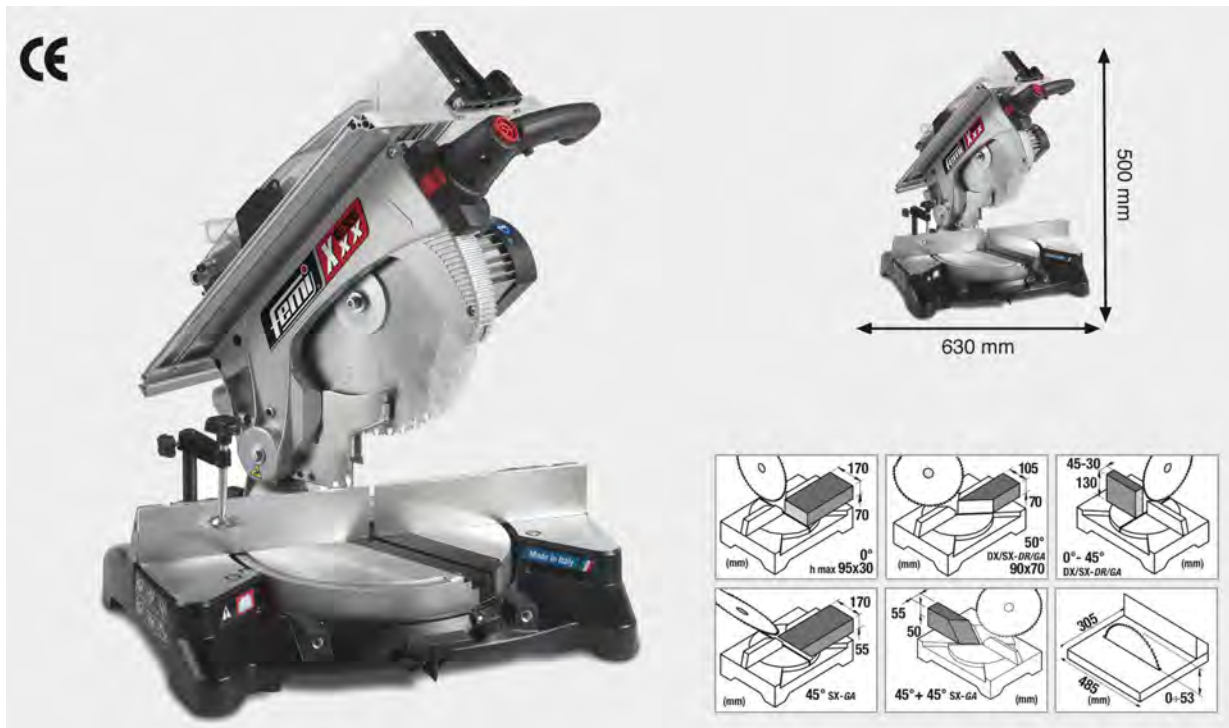

- **Motore monofase 230 Volt**
- Troncatrice combinata dalle grandi capacita' e prestazioni di taglio.
- Settori di utilizzo: carpenterie, fabbri, serramenti, falegnameria, montatori, manutentori, officine di trasformazione.
- Struttura in alluminio pressofuso, con movimenti su cuscinetti della tavola rotante, della testa e dello snodo.
- Controllo elettronico della funzione antiripristino di sicurezza.
- Impugnatura ergonomica frontale con comandi evidenziati per la massima sicurezza d'uso.
- Bocchetta di aspirazione di diametro 40mm per essere collegata ad appositi aspiratori.
- Angolo di taglio regolabile da 0° a 50° destra e sinistra, con dispositivo di bloccaggio semiautomatico a 0° - 15° - 22,5° - 30° - 45°. Taglio inclinato da 0° a 45° a sinistra. Taglio combinato 45° + 45° a sinistra.
- Motore a induzione silenzioso e potente da 1500 watt.
- La macchina e' predisposta per il montaggio di morsetti verticali e frontali per bloccare in modo stabile il pezzo da tagliare. Tali articoli sono ordinabili separatamente.
- Utilizzabile anche con dischi da taglio di diametro 300 mm, mediante regolazione del pomello fine corsa.
- Dotazione di serie: lama per legno in widia da 305mm, set di chiavi per la regolazione.

9

Code	Desc.
4170015950	XXXEVO

Spare Parts				
Article	Code	Description	Photo	
DISC FOR CUTTING ALUMINIUM BLADE Ø 305 Ø HOLE 30	417RC12150	664	-	
DISC FOR WOOD CUTTING BLADE Ø 300 Ø HOLE 30	417RC12155	669	-	
DISC FOR CUTTING ALUMINIUM BLADE Ø 300 Ø HOLE 30	417RC12160	674	-	

Tecnical Features	
Weight kg	23,5
Spessore max taglio superiore mm	50
Diametro lama x foro centrale mm	305 x 30
Taglio max 0° mm	170 x H70
Power output	1500 W
Max. revolutions when idling No.	2850 rpm
Tensione	230 V

## 1520W electric polisher roller

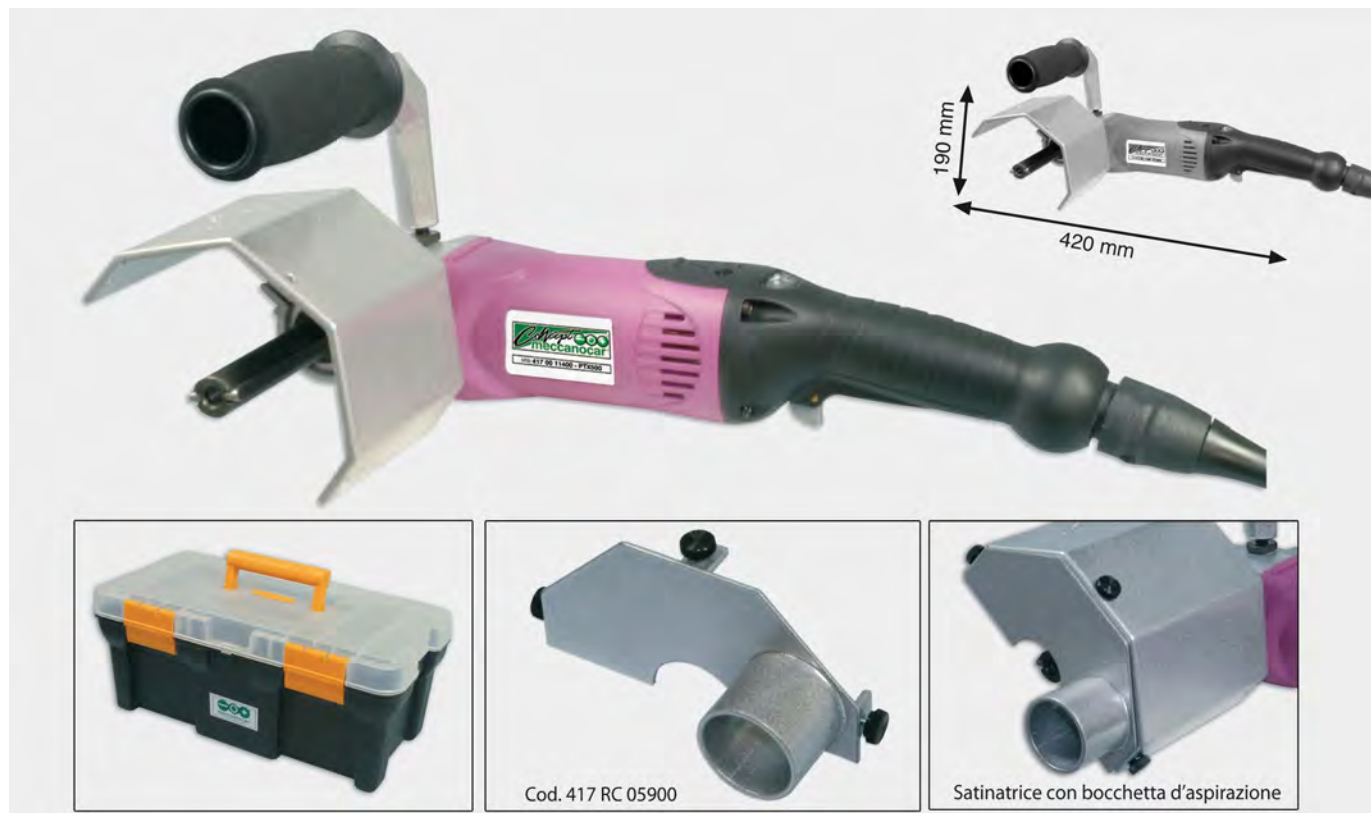

- Tool robust and easy to handle and powerful 1520W motor.
- Applications: steel structures.
- Ideal for abrasion, sanding, polishing, calendering and polishing of tubes and flat surfaces: metal, stainless steel, aluminum, hard plastic materials, wood.
- Powerful motor with adjustable speed 'to adapt the operation to any type of abrasive roller, felt, cotton and the like.
- Roll holder shaft diameter 19 mm. with double key drive for the proper locking of the rollers.
- Protective cover wrap and adjustable, with possibility 'of applying cater for dust extraction 417RC05900 our code.
- Ergonomic anti-vibration side handle and rear handle rubber grip.
- Service cover for quick access to the couple brushes 417RC06200 our code.
- Bundled in plastic case for transport.

Code	Desc.
4170011400	PTX500

Tecnical Features	
V/Hz power supply	220 5
Potenza assorbita (W)	1520
Weight kg	3,1
Diametro massimo rulli mm	100
Shaft diameter mm	19

Spare Parts		
Article	Code	Description
Side closure suction nozzle	417RC05900	185
Clamping screw rollers	417RC06000	186
Electric cable parts	417RC06100	187
Replacement brushes	417RC06200	188/A
Roller grinding and polishing	Vedi 34200	-
Polishes	Vedi 41100	-

## Combined single-phase bench grinders



- Grinding machines Bench professional with aluminum body, steel guards thick, interlock Antireset.
- 50 Hz single-phase power 220 volts-, available with disc diameter 150 mm with central hole of 16 mm., And a diameter of 200 mm disc. with a central hole of 20 mm.
- Protective cap of the abrasive disk of thickness 3 mm., With protection slides orientable, protective cover of the brush of thickness 3 mm., With a predisposition for the dust suction.
- Suitable for all types of work in the workshops which, sharpening tools, burrs, polishing, peeling, etc.
- Standard equipment: protective covers, accessories for mounting disks.
- Warning: The machine is supplied without discs and brushes. To use it is recommended to provide the appropriate accessories.

Code	Desc.	Disc diameter mm
4170007900	CE9	150x20x16
4170008000	CE10	200x25x20

Technical Features	
Dimensions cm.	51x24x31   65x29x36
Brush diameter mm	Hole 16 150   200 Hole 20
Weight kg	12,2   19,9
Grinder diameter	150x20x16   200x25x20
Velocità di rotazione giri/min	2.800   2.800
Power output HP	0,5   1,0
Potenza assorbita (W)	375   750
Power supply	220/50   220/50
Modello	CE9   CE10

Spare Parts	
Article	Code
Vitrified abrasive wheels	44300*****
Brushes	44300*****/49400*****

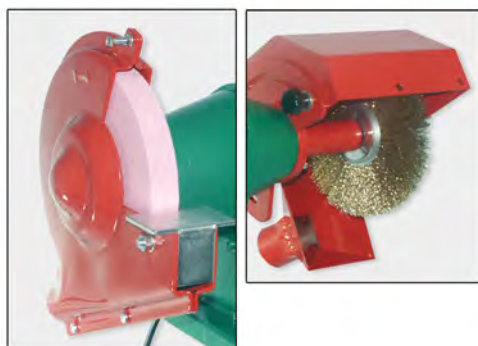

## Columns for bench grinders



- Steel columns painted to fire, to secure the support of our bench grinders.
- Equipped with tray pieces, or for water cooling.
- Holes on the crankcase for eventual fixing, perforated base for locking the machine.
- Attention: to provide the right fit column for each type of machine.

DIMENSIONI E PESI		
	CVE1	CVE2
Altezza mm	700	700
Dimensioni piano mm	380x380	380x380
Dimensioni base mm	285x345	335x385
Peso Kg	26,0	33,0

Code	Desc.	For article
4170008100	CVE1	CE9
4170008150	CVE2	CE10

## Groover to diamond disks

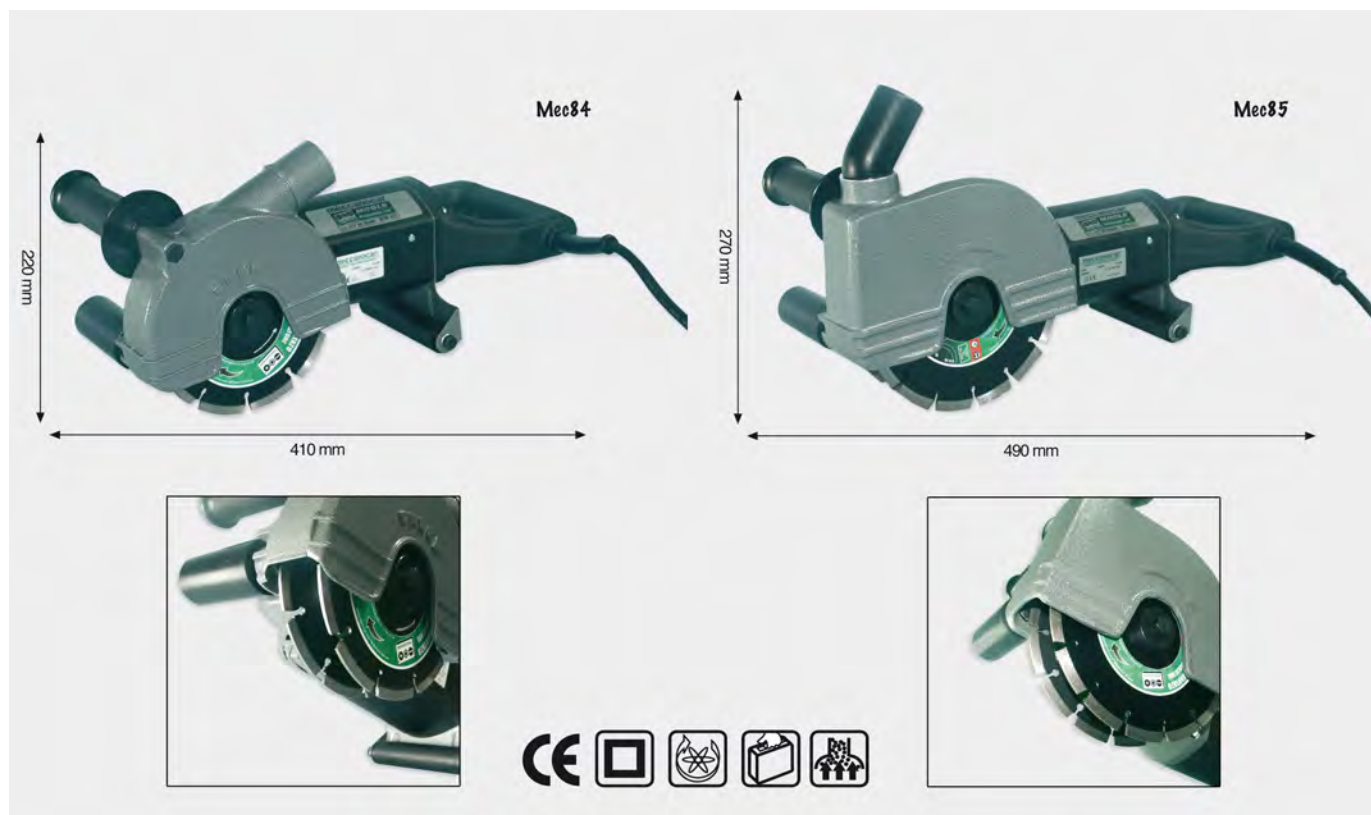

- Milling machines double diamond disc for the making of grooves on all types of masonry material, even the most 'hard and abrasive.
- Rugged construction. Die-cast aluminum powder coated with filler for vacuum integrated, hardened steel gears for long life, electronic pointer on the handle and overload protection against overload and overheating.
- Compact design, easy to handle and low weight, optimal synchrony between motor, gear and speed for performing traces in one step, starting slow controlled electronically.
- Electronic detachment of operation in case of overload or incorrect working angle. Immediate restart.
- The model MEC85 and 'able to achieve markings with width up to 43 mm. Ideal for professionals sanitary fixture.
- Standard equipment: double diamond wheel, keys for replacement discs, metal carrying case.

Code	Desc.	Model
4170008400	MEC84	Groover DISC 150 MM.
4170008500	MEC85	Groover DISC 180 MM.

Tecnical Features	
Modello	MEC84   MEC85
Weight kg	5.6   6.0
Elettronica di controllo	green / red   green / red
Elettronica	Yes   Yes
Discs diameter mm	150   185
Central disc hole diameter mm	22.2   22.2
Profondità di taglio mm	7-45   15-60
Larghezza di taglio mm	7-35   9-43
Max. speed rpm	7.800   4.100
Potenza assorbita (W)	1.800   1.800

Spare Parts		
Article	Code	Description
COUPLE BRUSHES	417RC02480	143A
DISCS FOR MEC84	417RC02250	135/150
DISCS FOR MEC 85	417RC02260	135/180



## Thermo 1.600W dual temperature



- Conveyor unit heaters with temperature switching on two stages. Practical and easy to use tool for the most diverse applications such as brazing, forming, drying, keying, paint removal, bonding and detachment points pasted, disinfections, thawing, preheat, etc..
- Switching of the air temperature on two-stage fixed via the ignition switch.
- Ideal for use by painters, installers, carpenters, mechanics, body shops, etc.

Code	Desc.
4170016160	HL 1620S

Tecnical Features	
Dimensions	250x200x75 mm
Supply voltage	230 V 50 Hz
Power output	1.600 W
Temperature	Grade 1:300°C - Grade 2 :500°C
Weight	670 g.
Portata d'aria	Grade 1: 240 l/min - Grade 2: 450 l/min.

## Thermo Electronic 2.300W 650 ° C



- Conveyor of warm air next-generation high performance.
- Continuous adjustment of the temperature rheostat via easily adjustable with one hand, filter incoming air, double turbine, heating system ceramic, temperature control via electronic probe.
- Continuous adjustment of the temperature and the indication through LCD, allows fine adjustment to better adapt to any type of work performed.
- Adjusting the air flow out of four preset positions.
- Ideal for use by painters, electricians, fitters, carpenters, mechanics, body shops, etc.
- Supplied in a metal carrying case.
- Available from a wide range of spouts To accommodate the tool to the type of machining to be carried out.

Code	Desc.
4170016170	HG 2320 E

Tecnical Features	
Dimensions	260x200x90 mm
Weight	960 g
Portata d'aria	Grade 1: 150 l/min. - Grade 2: 150-500 l/min.
Supply voltage	230 V 50HZ
Power output	2.300 W
Temperature	Grade 1: 250°C-350 l/min. - Grade 2: 350°C-400 l/min. - Grado 3: 450°C-500 l/min. - Grado 4: 550°C-400 l/min.

## Reflector nozzle for hot air tool HG 2320 E



- Welding pipes or threading pipe.

Code	Desc.
417RC01300	51

## Window nozzle for hot air tool HG 2320 E



- It protects from overheating by deflection, for example in narrow spots.

Code	Desc.
417RC01310	52

## Soldering reflector nozzle for hot air tool HG 2320 E



- Welding and threaded sleeves welding and heat shrinkable.

Code	Desc.
417RC01320	53

## Reduction nozzle 14 mm for hot air tool HG 2320 E



- To heat specific points when they melt solder joints or welds datatype of PVC, etc.

Code	Desc.
417RC01330	54

## Surface nozzle for hot air tool HG 2320 E



- To be used with 14mm round nozzle
- Nozzle flow of heat expanded, to engage on our round nozzle 14mm diam, cod. 417 RC01330-54.
- Suitable for welding of tarpaulins, truck tarps type, etc. in conjunction with the pressure roller 417 RC 01350.

Code	Desc.
417RC01340	55

## Manual pressure roller for hot air tool HG 2320 E



- Pressure roller manual useful to crush the material evenly heated to bond.
- Indicated for the gluing strips of any material and of tarpaulins PVC.

Code	Desc.
417RC01350	56

## Aspire solids / liquids 3300 W-77 liters



- Industrial vacuum cleaner for solids and non-flammable liquids, equipped with three motors two-stage, stainless steel tank 77 liters, high strength for heavy work of all kinds and industrial cleaning.
- Suitable for every field of work where necessary a great suction power: car washes, car dealerships, truck drivers, cleaning environments, industries in general.
- Accessories and stainless steel body, the possibility of ignition of the three separate motors to select the desired power, stem folding for easy emptying and cleaning the inside, sponge filters and washable polyester.
- It equipped as standard with all accessories for cleaning floors, machinery and vehicles and aspiration of liquids, with pipe diameter 40 mm length 2.5 meters, sponge filter 36 liter, polyester filter.
- Available optional: cartridge filter hepa the detention of mites, pollen and allergens.
- Antifoam device to be fitted inside the vacuum cleaner for liquids containing detergents.

Code	Desc.
4170015790	AR4400

9



Diametro imbocco accessori 44 mm

\*\* Articoli forniti di serie

\* Articoli a richiesta

Spare Parts			
Article	Code	Description	Photo
Hose length 2.5 meters, diameter 40 mm	417RC12050**	564	1
Flat lance	417RC11800**	539	2
brush lance	417RC11810**	540	3
Full Brush for floors	417RC11820**	541	4
Full brush for liquids	417RC11830**	542	5
HEPA cartridge filter	417RC11840*	543	6
Foam cleaner for sucking up liquids	417RC11850**	544	7
Polyester filter for dust extraction	417RC11860**	545	8
Anti-foam device	417RC11870*	546	9
Fixed wheel	417RC11880*	547	-
Castor wheel	417RC11890*	548	-
40mm diameter flexible hose 15 meters	417RC12060*	565	-
Kit terminals for flex hose	417RC12070*	566	-
Extension plastic 45cm	417RC12080*	567	-

Tecnical Features	
Weight kg	29
Dimensions cm.	59 X 62 X 106
Barrel total capacity l.	77
Livello rumore dB(A)	68
Max. Power	3300
Air sucked m3/h	510
Depression mm H2O	2250
V/Hz power supply	220/50
Motori n°/stadi	3 engines / 2 stages



## Aspires shavings Industrial 3600 W-77 liters



- Industrial vacuum cleaner designed to clean metal shavings from also mixed with liquids and lubricants of jobs and the machine tool, indispensable in the workshops of all kinds.
- Especially suitable for the cleaning of the machine tools and jobs around them. It allows you to vacuum without any problem scrap metal and shavings including cutting, alone or mixed with cutting fluids and coolants in general. Possibility to use the shavings aspires also as aspirator for solids or solids and liquids traditional.
- Large stainless steel tank, internal security system "cyclone" to protect the motor and the moving parts. Stem folding for easy emptying and cleaning.
- It equipped with three double stage motors with separate switches to select the desired suction force.
- Equipped as standard with anti-static tube can diameter 50 mm and length 2.5 m, 4 antistatic nozzles of various shapes to reach the furthest corners of machinery and floors available Optional kit internal basket in stainless steel for the separation of chips metallic oils, polyester filter tapered to a dust extraction adapter for mounting tubes 40 mm diameter for the intake of solids and liquids, complete kit for the use as an aspirator for solids and liquids with stainless steel tubes.
- For the bulk of the spare parts kits suction solid and liquid you can use parts of our solid and liquids vacuum 3300 W-77 liters code 417 00 15800 - AR4800.

Code	Desc.
4170015810	AR4900



\*\* Articoli forniti di serie  
\* Articoli a richiesta

Spare Parts				
Article	Code	Description	Photo	
PU anti-static tube diameter 50 mm length 2.5 meters	417RC11940**	553	1	
Lancia conical antistatic	417RC11950**	554	2	
Windy wavy antistatic	417RC11960**	555	3	
Truncated cone antistatic	417RC11970**	556	4	
Lancia galvanized length 500 mm	417RC11980**	557	5	
Galvanized sleeve junction accessories	417RC11990**	558	6	
Cartridge filter in polyester	417RC12000**	559	7	
Internal system "Cyclone"	417RC12010**	560	8	
Foam cleaner for sucking up liquids	417RC11850**	544	9	
Polyester filter for dust extraction	417RC11860**	545	10	
Kit internal basket for separation shavings / oils	417RC12020*	561	11	
Adaptor sleeve for pipes of diameter 40 mm	417RC12030*	562	12	
Complete kit for use as solid and liquids vacuum	417RC12040*	563	-	
Fixed wheel	417RC11880*	547	-	
Castor wheel	417RC11890*	548	-	

Tecnical Features	
Weight kg	30
Dimensions cm.	50 X 60 X 106
Barrel total capacity l.	77
Livello rumore dB(A)	68
Max. Power	3600
Air sucked m3/h	645
Depression mm H2O	2400
V/Hz power supply	220/50
Motori n°/stadi	3 engines / 2 stages



## Automatic vacuum-1400W 37 liters



- Industrial vacuum cleaner for non-toxic dusts also fine with a large suction force, additional outlet for starting and stopping with power tools, automatic shaking of the filters at regular intervals, tank and stainless steel accessories.
- Suitable for every field of work where necessary a great suction power and easy transportation: car washes, car dealerships, truck drivers, cleaning environments, carpenters, assembly of windows and frames, electricians, plumbers, etc..
- Automatic start and stop with auxiliary jack for the application of power tools with dust extraction with a maximum power of 2,000 watts. Series is to clean the filter cartridge. Automatic shaking the dust sucked for longer life without clogging.
- It equipped as standard with all accessories for cleaning floors, machinery and motor vehicles with tube diameter 40 mm length 2.5 meters. Pipe for connection of power tools diameter 28 mm length 3.3 meters with adjustable sleeves, cartridge filter is to clean.
- Available optional: polyester filter conical and polyester filters disposable 36 liter, both required for dust extraction purposes.



Code	Desc.
4170015800	AR4800

9



Diametro interno accessori 44 mm



\*\* Articoli forniti di serie

\* Articoli a richiesta

Spare Parts			
Article	Code	Description	Photo
Hose length 2.5 meters, diameter 40 mm	417RC12050**	564	1
Flat lance	417RC11800**	539	2
Nozzle brush	417RC11810**	540	3
Brush Full for floors	417RC11820**	541	4
Hose length 3.3 meters, diameter 28 mm	417RC11900**	549	5
Cartridge filter Conical	417RC11910**	550	6
Conical filter in polyester	417RC11920*	551	7
Polyester filters disposable 36 liter (5 pieces)	417RC11930*	552	8
Castor wheel	417RC11890*	548	-
40mm diameter flexible hose 15 meters	417RC12060*	565	-
Kit terminals for flex hose	417RC12070*	566	-
Extension plastic 45cm	417RC12080*	567	-

Tecnical Features	
Weight kg	13,9
Dimensions cm.	41 X 41 X 81
Barrel total capacity l.	37
Livello rumore dB(A)	60
Motori n°/stadi	Motor 1 / 2 stages
Max. Power	1400
V/Hz power supply	220/50
Depression mm H2O	2400
Air sucked m3/h	215

## Professional sharpener Drill Doctor



- Affilapunte elettrico professionale per la perfetta riaffilatura di punte per foratura in HSS, Metallo Duro, Cobalto, Titanio, e con punta in Widiarm per muratura. Ricrea l'affilatura perfetta potendo scegliere fra due angolazioni di 118° o 135° per il modello 500X, o da 115° a 140° con il modello 750X, e permette di creare lo "Split Point" o punta autocentrante.
- Indicato per ogni tipo di professionista, permette il riutilizzo delle punte anche rotte o spezzate. Risparmio economico enorme per l'utilizzatore.
- La macchina funziona con corrente di rete 220 Volts, è leggera e facilmente trasportabile, dispone di predisposizione per l'applicazione di un aspiratore per le polveri. La mola al diamante montata di serie garantisce circa 400 affilature prima di dover essere sostituita, unico materiale di consumo della macchina.
- Disponibile in due versioni a seconda delle prestazioni occorrenti, fornite entrambe in valigetta in plastica per trasporto, libretto dettagliato di istruzioni, cd-rom con video sul funzionamento ed il corretto utilizzo, chiave per smontaggio e rimontaggio mola.
- **ATTENZIONE:** gli affilapunte Drill Doctor non sono adatti per la riaffilatura di punte per staccapunti, frese o simili.

Code	Desc.	Ø punte mm	Dimensions mm	Weight Kg.	Spare Parts		
					Article	Code	Desc. Grain
4170015760	DD750X	da 2,5 a 19	200 X 125 X 110 h	1,4	Grinding parts	417RC15165	1133 180
4170016150	DD500X	Da 2,5 a 13	200 X 125 X 110 h	1,4			

## Professional labeling Meccanocar



- Etichettatrice professionale Meccanocar.
- Design compatto e portatile, con guscio protettivo in gomma.
- Costruisce etichette dettagliate, leggibili e durevoli.
- Simboli elettrici, audio e video incorporati. Memorizzazione delle etichette piu' utilizzate. Stampa su nastri con diversa ampiezza da 3,5; 6; 9; 12mm.
- Taglia nastro su lato macchina.
- Display LCD di facile lettura da 12 caratteri.
- Funzionamento con 6 batterie AAA (non incluse) ns codice 512 00 01030 o tramite presa elettrica grazie all'adattatore in dotazione.
- Stampa su una o due righe(su nastri 9 e 12mm). Funzione di impostazione margini identici su entrambi i lati del nastro.
- Settore di utilizzo: elettricisti, posatori di cavi, elettrauti, ufficio.
- Ideale per la creazioni di etichette per: quadri elettrici, identificazione cavi, etichettare fascicoli e oggetti.
- Contenuto: etichettatrice PT7100VP, adattatore, un nastro con fondo giallo e scritta nera (ns cod. 443 00 55046, istruzioni multilingua, valigetta in plastica antiurto.

Code	Desc.	Article
4430055020	PT7100VP	-
4430055025	IWB-500	ADAPTER PT7100VP

Tecnical Features	
Dimensions	19x9x5H cm
Peso (batterie incluse)	0,477 Kg
Memoria testo	720 characters
Impostazione lungh. etichette	YES (30 TO 300mm)
N° copie di stampa	9
Dimensioni testo	Large, medium, small
Text width size	Small, normal, large
Stampa	Horizontal, vertical or mirror
Tipo di carattere	Helsinki (uppercase and lowercase)
Stili di stampa	9 (normal, bold, outline, shadow, italic, bold italic, strikethrough italics, italics ombreg., Vertical)
Tipi cornici	6 (pointed, round, candy, didactic, banner, wood)
AC power supply	100V-240V 50-60Hz
DC power supply	9V/1,6A
Velocità di stampa	10 mm/sec
Maximum print height	9 mm

## Tapes Labeling Meccanocar



- Nastri laminati per uso professionale modello TZ.
- A differenza dei nastri tradizionali, quelli Meccanocar rimangono leggibili nel tempo e non si scollano.
- Pellicola trasparente che protegge l'etichetta da: luce del sole, abrasioni, umidità, caldo, freddo, i più comuni prodotti per la pulizia.
- Non si inceppano all'interno della macchina. Facili da sostituire, basta aprire il coperchio della etichettatrice ed inserire un nuovo nastro.
- L'etichettatrice professionale Meccanocar rileva automaticamente la larghezza del nastro inserito.
- Adatte per tutte le superfici piane, e per le applicazioni su cavi elettrici si consiglia l' utilizzo del nastro flessibile.
- Lunghezza dei nastri 8 metri.

Code	Desc.	Length <i>mt</i>	Width <i>tape</i>	Characteristics	For surface
4430055027	9x8MT-BN	8	9 mm	WRITTEN BLACK WHITE FUND	FLAT
4430055029	9x8MT-NB	8	9 mm	FUND WRITTEN BLACK WHITE	FLAT
4430055030	9x8MT-GN	8	9 mm	WRITTEN FUND YELLOW BLACK	FLAT
4430055031	9x8MT-FXGN	8	9 mm	YELLOW RIBBON FLEXIBLE FUND WRITTEN BLACK	CURVA
4430055032	9x8MT-RN	8	9 mm	RED BACKGROUND WRITTEN BLACK	FLAT
4430055040	12x8MT-TN	8	12 mm	BACKGROUND TRANSPARENT WRITTEN BLACK	FLAT
4430055041	12x8MT-BN	8	12 mm	WRITTEN BLACK WHITE FUND	FLAT
4430055042	12x8MT-FXBN	8	12 mm	TAPE FLEXIBLE FUND WRITTEN BLACK WHITE	CURVA
4430055043	12x8MT-BB	8	12 mm	WRITTEN BLUE WHITE FUND	FLAT
4430055044	12x8MT-NB	8	12 mm	BACKGROUND WRITTEN BLACK WHITE	FLAT
4430055046	12x8MT-GN	8	12 mm	YELLOW BACKGROUND WRITTEN BLACK	FLAT
4430055047	12x8MT-FXGN	8	12 mm	YELLOW RIBBON FLEXIBLE FUND WRITTEN BLACK	CURVA
4430055048	12x8MT-RN	8	12 mm	RED BACKGROUND WRITTEN BLACK	FLAT
4430055049	12x8MT-RB	8	12 mm	BACKGROUND WRITTEN RED WHITE	FLAT



## Diamond blades sectors for building



- Cutting discs with laser welded diamond segments, each indicated for use on various building materials such as granite, concrete, reinforced concrete.
- High cutting speed, high durability, low noise and vibration.
- Suitable for use in dry with angle grinders portable machines. Center hole fixing diameter 22.2 mm.
- Products certified for safety according to EN 13236.

Code	Desc.	Diam. mm	Vel. max giri/min.
417RC02190	131/115	115	80 M/S-13.300
417RC02195	131/125	125	80 M/S-12.200
417RC02200	131/230	230	80 M/S-6.600

## Chucks with external plastic



- Chucks for drills and electric screwdrivers and battery, with internal and external hex drilled for assembly and disassembly.
- The hollow body for clamping to the shaft.
- Ergonomic shape with metal shells, ease of use, high concentricity.
- For maintenance and lubrication we are recommended to use our spray cod. 411 00 15265-2881.
- \* Shaft diameter: 1 / 2x20 = 12.7 mm. 3 / 8x24 = 9.53 mm.

Code	Desc.	Capacity	Attachment	Ext. Diameter	Lunghezza aperto	Lunghezza chiuso	Ref. picture
417RC00080	2-1/10	1-10 mm	1/2 X 20 UNF	42,7 mm	55 mm	60,9 mm	1
417RC00090	2-1,5/13	1,5-13 mm	1/2X 20 UNF	42,7 mm	64,5 mm	72,4 mm	1
417RC02185	150-1/10	1-10 mm	3/8 X 24 UNF	42,7 mm	55 mm	60,9 mm	2
417RC00085	2-1,5/13-3/8	1,5-13 mm	3/8 X 24 UNF	42,7 mm	64,5 mm	72,4 mm	1

## Spindles Keyless for percussion drills

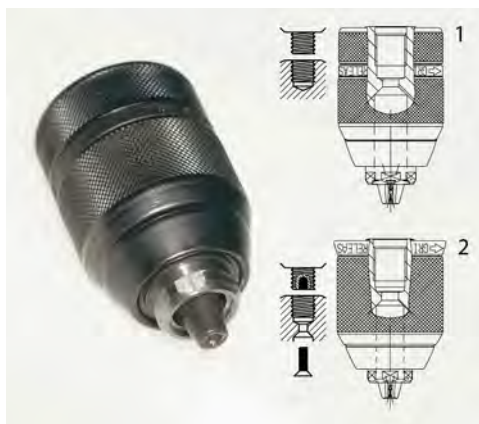

- Chucks with body made entirely of steel for drills and electric screwdrivers and battery with percussion, with drilled internal and external hexagon for assembly and disassembly.
- Safety shutter at the end of closing against loosening during work. Jaws with carbide-tipped versions with opening up to 13 mm.
- The hollow body for clamping to the shaft.
- Ergonomic shape with metal shells, ease of use, high concentricity.
- For maintenance and lubrication we are recommended to use our spray cod. 411 00 15265-2881.
- \* Shaft diameter: 1 / 2x20 = 12.7 mm. 3 / 8x24 = 9.53 mm.
- Photo 1 = With metal shell with and without locking ring
- Photo 2 = For machines with spindle lock

Code	Desc.	Capacity	Attachment	Ext. Diameter	Lunghezza aperto	Lunghezza chiuso	Photo
417RC00100	3-1/10	1-10 mm	1/2 X 20 UNF	42,7 mm	55 mm	60,9 mm	1
417RC00105	3-1/10-3/8	1-10 mm	3/8 x 24 UNF	42,7 mm	55 mm	60,9 mm	2
417RC00110	3-1,5/13	1,5-13 mm	1/2 x 20 UNF	42,7 mm	64,5 mm	72,4 mm	1

## Spindle rack for rotary drills and percussion



- Chucks with steel rack for rotary drills and percussion.
- Internal female threaded connection, the hollow body for clamping shaft.
- Article 417 RC 00140 specific drills core drills.
- Supplied with screw and key.
- For maintenance and lubrication we are recommended to use our spray cod. 411 00 15265-2881.
- \* Shaft diameter: 1 / 2x20 = 12.7 mm. 5 / 8x16 = 15.88 mm.

Code	Desc.	Capacity	Attachment	External Diameter	Lunghezza aperto	Lunghezza chiuso
421RC00620	219667	1-10 mm	1/2 X 20 UNF	34,5 mm	49,5 mm	61 mm
417RC00130	4-1.5-13	1,5-13 mm	1/2 x 20 UNF	42,8 mm	59 mm	74 mm
417RC00140	4-3/16	3-16 mm	5/8 x 16 UNF	50 mm	68,5 mm	87,5 mm

## Replacement keys for chucks rack



- Steel keys with teeth DIN 6349 for our spindle rack.
- Also adaptable spindle rack of other brands. It is advisable to check the measurements of the original key.



Code	Desc.	Measure	D mm	L mm	For mandrel
417RC00150	5-10	S3	8	50	1-10
421RC00650	221378	S2	6	51	1-10/1,5-13
417RC00170	5-3/16	S3T	8	51	4-3/16

## Keyless chuck for drill presses



- Chuck steel, running heavy drills stationary column.
- Large clamping force, massive clamping ring, weight and size limited.
- Keyless during drilling, clamping force reliably even in the harshest conditions.
- Attack female taper B18. Adaptable to most drill presses using our adapters cod. 417 RC 00190-7 M3-B18 and cod. 417 RC 00195-7 M2-B18.
- For maintenance and lubrication we are recommended to use our spray cod. 411 00 15265-2881.
- \* Conical B18 = 18 mm diameter mandrel entrance.

Code	Desc.	Opening	Attachment	Ext. Diameter	Lunghezza aperto	Lunghezza chiuso
417RC00180	6-3/16	3-16 mm	B18	50 mm	95 mm	107 mm

## Accessories for drills taper



- Accessories for drills taper
- Attacks double cone for the assembly of our spindles cod. RC 00180-6- 417 3/16 with conical on drill presses and heavy drills.
- Construction in concrete and ground.
- Available for drills with taper No. 2 and 3.
- Attack taper No. 3 for Chuck taper B 18 (drawing 1)
- Attack taper No. 2 for Chuck taper B 18 (drawing 2)

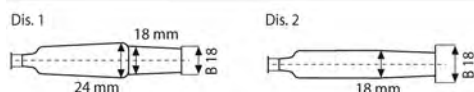

Code	Desc.	Article
417RC00190	7 M3-B18	Morse taper No. 3 spindle B18 cod. 417 RC 00180
417RC00195	7 M2-B18	Attack taper No. 2 spindle B18 cod. 417 RC 00180

## Reduction Sleeves for taper



- Taper bushes reduction for attacks drill taper.
- Construction steel according to DIN 2185, external taper adjusted.

Code	Desc.	Reduction
417RC00200	8 M3-2	Da cono Morse n° 3 a cono Morse n° 2
417RC00210	8 M3-1	Da cono Morse n° 3 a cono Morse n° 1
417RC00215	8 M4-3	Da cono Morse n° 4 a cono Morse n° 3

## Spindle Screwdriver hexagonal connection 1/4 "



- Keyless chuck, outer body of plastic material with a clamping range of 1 to 10 mm.
- Hexagonal 1/4 "male for fast assembly on the trees of electric screwdrivers, battery or tires for use as drill.
- For maintenance and lubrication we are recommended to use our spray cod. 411 00 15265-2881.

Code	Desc.
417RC01190	40-1/4

## Bevel gearbox with spindle



- Practical Angle drive 90 ° with keyless chuck with external plastic, open from 1 to 10 mm.
- Realisation of heavy metal with movements entirely on ball bearings for maximum precision and reliability.
- Very useful for working in confined spaces with spikes or bits. Applicable on any spindle electric drills or battery.
- Hexagonal attachment for fast fixing and no slippage during use.
- For maintenance and lubrication we are recommended to use our spray cod. 411 00 15265-2881.

Code	Desc.
417RC01200	41 A

## SDS-Max adapter / SDS-Plus



- SDS-Max adapter / SDS-Plus
- Adapter for hammers electro mounting of drill bits and chisels with quick SDS-Plus on machines with SDS-Max.

Code	Desc.	Entrance	Uscita
417RC02490	144	SDS-Max	SDS-Plus

## Spindle adapter SDS-Plus



- Spindle adapter SDS-Plus.
- Adapter to mount any type of chuck, chuck is both rack with female thread 1/2 "x 20 UNF, any electro-pneumatic hammer with quick SDS-Plus.
- Supplied complete with center retaining screw for use for screwing and unscrewing.

Code	Desc.	Rapid attachment	Male thread
417RC00470	17 SDS-Plus	SDS-Plus	1/2"X20UNF

## Whips mixing with hexagonal shank



- Whips to mixing of different materials, with movement from the bottom upwards and vice versa.
- Hexagonal for the application of spindles with rack and keyless.
- Model of diameter 80 mm., With mixing from top to bottom. Spatter.
- Suitable for: mixing of water-based paints, lacquers, tempera for walls, glue for wallpaper.

Code	Desc.	Ø mm	Length mm	Kg min. mixture	kg max. mixture
417RC00450	16-80	80	400	5	10





- Model of diameter 120 mm., With mixing from bottom to top.
- Suitable for: ready plaster, concrete, mortar, floor polish.

Code	Desc.	Diam. mm	Length mm	Kg min. mixture	kg max. mixture
417RC00460	16-120	120	600	15	25

## Column bracket for portable drills



- Column support universal portable drills with standard collar diameter 43 mm.
- It equipped with integrated strain relief for maximum safety, bit holder, depth stop.
- Variable stroke adjustment with scale of 70 mm.

Code	Desc.
417RC02175	140

Tecnical Features	
Base dimensions mm	160X165
Lunghezza colonna mm	450
Column diameter mm	35
Working stroke mm	110
Sporgenza mm	43
Collar tightening diameter mm	43
Weight kg	2,3

9

## Clamp support column



- Straining clamp for professional support column, our article RC 417 02175.
- Grip hollow profiled steel jaws with run special profile of the jaws prism for clamping pipes in every position, cast iron construction stable.
- Hole distance: 135 mm. Max opening: 100 mm. Jaw width: 100 mm.

Code	Desc.
417RC02180	140M

## Lamp Twilight



- Lamp twilight intermittent light.
- Supplied without batteries.
- To use insert 2 batteries ns / cod. 446 00 08021-4038/1.
- Equipped with fixing system.

Code	Description
4460008022	4038/2 - Yellow
4460009500	4302 - Orange

## Red lamp for construction site



- Lamp construction site red light fixed.
- Supplied without batteries.
- To use insert 2 batteries ns / cod. 446 00 08021-4038/1.
- Equipped with fixing system.

Code	Description
4460008023	4038/3 Red

## Portable lamp LED 6V



- Supplied without batteries.
- It can work with a stack our cod. 08021- 446 00 4038/1 or 4 batteries torch our cod. 512 00 01000-350.

Code	Desc.
4460009505	4303

## Flexible Lamp



- Portable lamp for inspections in hard to reach places (inside the dashboard, engine room, etc ..).
- Thanks to the flexible probe 25 cm long can brighten areas that can not be reached.
- The krypton bulb illumination with an effective and focused on the point concerned.
- Equipped with hood transparent scratch-resistant and insulating causing no damage and short circuit.
- Easy to carry thanks to the practical attack.
- Powered by two 1.5V batteries not included.
- Batteries inserted art. 5120001020-360-LR6.

Code	Description
5120000310	310
5120000315	315 - Replacement Lamp

## Kit Lights and mirrors



- Kits with lights and mirrors inspection in practical case.
- Product suitable for workshops cars, motorcycles and industrial vehicles, dealerships, body shops, electrician for cars, installers hi fi, campers, airports, marine workshops, hauliers and earthmoving in general.
- The kit is composed of a series of tools for the inspection in the hidden points, for the verification of damage or problems.
- The trousse comprises a handle on which to mount various extensions, to support a mirror to hidden points, a magnet for recovery small parts, a lamp with high efficiency LED for illumination, a LED to ultraviolet light can highlight products tracers reveals leaks.
- The particular shape of the tool allows maximum access to even the most inaccessible.
- The kit includes: (A) 1 folding mirror (L. 7 cm - width. 4.5 cm), (B) 1 flexible shaft (L. 23 cm), (C) 1 handle with power button (L. 18 cm), (D) 1 white bulb, (E) 1 UV bulb, (F) 1 magnet (length. 7 cm), (G) 1 extension curve (L. 20 cm), (H) 1 extension Straight (L. 20 cm).
- The tools are contained in a practical case with thermoformed in order to keep the tools. The lights can be powered by 3 AA batteries (type ns. 512 00 00120) is not included in the kit.

Code	Description
4770004770	336 - KIT LIGHTS AND MIRRORS
4770004771	336 / R WHITE LAMP REPLACEMENT
4770004772	336 / RU UV LAMP REPLACEMENT

## Magnifier articulated with LED lighting



- Powerful magnifying glass mounted on a magnetic base with articulated arm, equipped with lighting with 14 LEDs, handy to zoom small details even in low light conditions.
- Very useful in all types of work: mechanical, electronic, electrical, maintenance, etc.
- Magnification up to 3X, dual power options with two AAA 1.5 Volt batteries or with transformer 220 V - 4.5 V supplied as standard.
- Constructed of optical glass, lens support and grip in shockproof plastic material weighted with the magnet and metal base to ensure maximum stability. Arm articulated in plasticized 25 cm long steel. Lens can be rotated by 150 ° on the support arm.
- Lens diameter 95 mm, total length 500 mm, weight 540 grams with batteries. Standard equipment: for mains power supply 220 V - 50 Hz with cable length of 190 cm, table metal support with screw terminal.

Code	Desc.
5120001220	506

Spare Parts			
Article	Code	Desc.	
Power pack 220 V - 4,5 V	5120001230	507	

## LED pocket flash light



- Anodized aluminum torch.
- High efficiency LED.
- Adjustable focus.



Code	Desc.
5120000010	10-IM33

PILE INSERIBILI	
CODICE	DESCRIZIONE
512 00 01020	360-LR6 ALCALINA
512 00 01200	400-FR6 LITIO

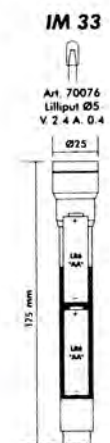



## Torch



- Torch rubber oil resistant.
- Button protected.
- Krypton lamp.
- Safety strap.

**ANTIURTO.  
IDEALE PER TUTTE  
LE CASSETTE UTENSILI.**

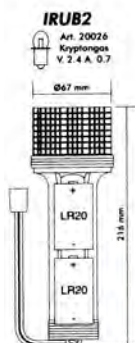

PILE ALCALINE INSERIBILI	
CODICE	DESCRIZIONE
512 00 01000	350-LR20 N°2xIRUB2

Code	Desc.
5120000060	60-IRUB2

## Winder with portable lamp without transformer



- Automatic cord complete with portable lamp, with recovery spring, suitable for application on the wall.
- Ideal for use in all workshops, self-repair, bodywork, motorcycle workshop, carpentry, etc.
- Cable reel with fluorescent bulb 11W white light.
- Type H05RN-F, cable length 15.5 meters (14 meters wrapped, 1.5 meters external), cable section 2x1 sq mm; length power cord 1 meter.
- Structure impact resistant plastic.
- Stop device cable rack, inserted every 50 cm.
- Fixing bracket wall made of sheet steel which allows the rotation of the cable reel.
- Supply voltage: 230V or 24V.
- Degree of protection IP 42 cable reel.
- Degree of protection IP 55 lamp.
- Built in accordance with IEC 1242, EN 60598-1, EN 60598-2-8, EN 61242, EN 60335-1, 626.
- Products meeting the requirements of the 2006/95 / EC, 2006/42 / EC, 2002/95 / EC.
- CE mark.
- NB: 24V models must be fed only at 24V; the use with different voltages irreparably damage the power supply circuit of the lamp.

Code	Description
3480100210	908-230V winder with fluorescent lamp
3480100220	909-24V winder with fluorescent lamp

Spare Parts		
Article	Code	Desc.
Ring nut parts	3480002575	432/G

## Winder with portable lamp with transformer 24V



- Automatic cord complete with portable lamp and transformer, with recovery spring, suitable for application on the wall.
- Ideal for use in all workshops, self-repair, bodywork, motorcycle workshop, carpentry, etc.
- Cable reel with fluorescent bulb 11W white light.
- Type H05RN-F, cable length 15.5 meters (14 meters wrapped, 1.5 meters external), cable section 2x1 sq mm. Power cord length 1 meter.
- Safety transformer: 25 VA power, supply voltage 230 V, output voltage 24 V circuit breakers with manual reset, places on the secondary, for the protection circuits and overloads.
- The primary and secondary winding are separated.
- Structure impact resistant plastic.
- Stop device cable rack, inserted every 50 cm.
- Fixing bracket wall made of sheet steel which allows the rotation of the cable reel.
- Degree of protection IP 42 cable reel.
- Degree of protection IP 55 lamp.
- Built in accordance with IEC 1242, EN 60598-1, EN 60598-2-8, EN 61242, EN 60335-1, 626.
- Products meeting the requirements of the 2006/95 / EC, 2006/42 / EC, 2002/95 / EC.
- CE mark.

Code	Description
3480200410	910-230V reel with fluorescent lamp and transformer

Spare Parts		
Article	Code	Desc.
Ring nut parts	3480002575	432/G

## Winder with lamp Led Strip 12-24 Volts



- Wall electric winder with lamp lighting "Led Strip" with very high light output and with white color.
- Ideal for use in all workshops. The use of the LED system allows unmatched brightness, a clear color of the light and easy on the eyes, a very high energy savings and an unmatched life expectancy than traditional lamps.
- It equipped with a total cable length of 15.5 meters, length of 1 meter of cable for power supply, adjustable wall bracket. Degree of protection IP64 lamp, IP42 degree of winder protection.
- Lamp with protected switch, rotated and swiveled hook disappearance, non-slip grip. Winder dimensions: 390 x 310 x 165 mm. Weight 4.5 kg.
- **WARNING:** the item must be powered with low voltage 12 or 24 Volts. No internal transformer.
- **Regulations: Rhos EN 60598-1 EN 60598-2-8 EN 60335-1 2006/95 CE 2004-108-CE 2011-65-UE**

Code	Description
3480100230	910

Tecnical Features	
Winder measures	390 x 310 x 165 mm
Weight	4,5 Kg
Degree of protection to the lamp shock	IK 09
Light flow	360 lm
Type electric cable	H05 RN-F - 2 x 1 mmq
Degree of protection of the lamp	IP64
Degree of protection of the winder	IP42
Power supply cable length (m)	1 m
Supply voltage	12 - 24 V dc/ac
Lamp cable length	15,5 m

## Winder with transformer and lamp Strip Led

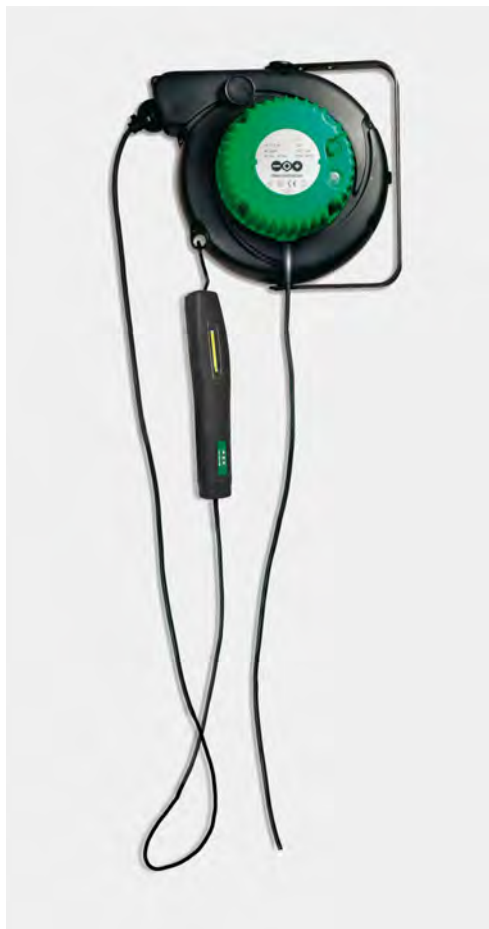

- Wall electric winder with 24 Volts low voltage transformer and lighting lamp "Led Strip" with very high light output and with white color. Power supply via mains voltage 220 V 50 Hz.
- Ideal for use in all workshops. The use of the LED system allows unrivaled brightness, a color of the light and relaxing light for the eyes, a very high energy savings and an unmatched life expectancy than traditional lamps.
- It equipped with a cable length of 15.5 meters, length of 1 meter of cable for power supply, adjustable wall bracket. IP64 degree of protection lamp, IP42 degree of winder protection.
- Lamp with protected switch, rotated and swiveled hook disappearance, non-slip grip. Winder dimensions: 390 x 310 x 165 mm. Weight 4.5 kg.
- **Regulations: Rhos EN 60598-1 EN 60598-2-8 EN 60335-1 2006/95 CE 2004-108-CE 2011-65-UE**

Code	Description
3480100240	924

Tecnical Features	
Weight	5,5 Kg
Winder measures	390 x 310 x 165 mm
Light flow	360 lm
Degree of protection to the lamp shock	IK 09
Degree of protection of the winder	IP42
Supply voltage	220 V – 50 Hz
Lamp cable length	15,5 m
Degree of protection of the lamp	IP64
Type electric cable	H05 RN-F – 2 x 1 mmq
Power supply cable length (m)	1 m

## Holder with and without cable IP20



- Lamp holder with switch admitted by Presidential Decree 547 "for use in dry places and not in contact with large metal masses."
- Grip anatomically shaped plastic anti-oil, anti-acid, anti-solvent.
- Wire cage steel hinge and reflector in galvanized steel.
- Lamp cap screw E27, maximum power 60W.
- Version with cable length of 10 meters, section 2x0.75 mm<sup>2</sup>, IMQ approved.
- IP20 protection.

	60W IP20
EN 60598-1	EN 60598-2-8
CEI 34-21	CEI 34-34
ART. 317 - DPR 547	

Code	Desc.	Model
3480000100	305 T	WIRELESS
3480000200	306 T	CABLE 10 mt IMQ

## Electric cable winder 1.8 Kw Max 3x1.5 sq mm



- Winder electric power lamps and power tools.
- New housing impact resistant plastic black.
- Built in accordance with IEC 1242, CE, responding to the security law 626, complete with thermal circuit breaker, protection degree IP42.
- Total cable length: 14 mt wrapped + 1 mt exterior, section 3x1.5 sq mm.
- Operating Temperature: -5 ° C to + 40 ° C.
- Max power cord wrapped 1200W, 1800W extended cable.

Code	Description	Cable	W avvolto	W steso
3480101000	1325 - WINDER CABLE 3x1.5	3x1,5	1200	1800

## Enrouleur manuel pour câble électrique.



- Enrouleurs manuels de cable électrique.
- Cable marque vde et aux normes.
- Dotes de disjoncteurs thermiques, frein de blocage.
- Modele 220V dote de 4 schuko + france.

Code	Desc.	Cable n. X mmq	Lung. mt	V Volts
3480100810	1230	3X1.5	25	220



## Manual electric cable winders



- Winders manuals of electrical cable constructed in accordance with IEC 1242, CE marked
- IMQ-branded cable and plugs taken under.
- Equipped with thermal circuit breaker, locking brake, steel support stand and external flanges in galvanized sheet.
- Models 220 V. Equipped with 2 outlets G 10/16 at 2P + T, 1 CEE socket 16 at 2P + T, 1 CEE plug 16 at 2P + T. 380 V models with 2 CEE sockets 16 3P + T, 1 CEE plug 16A 3P + T.

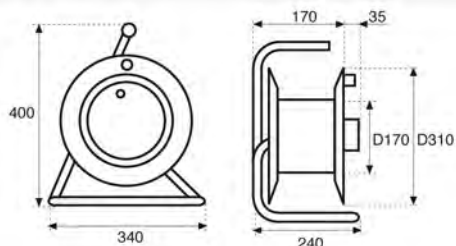

Code	Desc.	Cable n. X mmq	Length mt	W avvolto	W steso	V Volts
3480100600	1226	3X1.5	40	1200	1700	220
3480100700	1227	3X2.5	40	1800	2800	220
3480100800	1228	4X2.5	30	2500	4500	380

## Spare parts for fluorescent lamp 308



- Spare parts for fluorescent lamps our codes: 348 00 01 300, 348 00 01 310, 348 00 and 348 00 01400 01410 no more provided.

Code	Desc.	Article
3480001500	308/R	Tubo fluorescente di ricambio 220/24 Volts
3480001600	508	Campana trasparente di ricambio
3480001415	308/24V	Circuito elettronico interno di ricambio 24 Volts

## Fluorescent lamp workshop



- Workshop lamp with fluorescent tube, very bright white light and last up to eight times longer than ordinary light bulbs.
- Less energy consumption, absence of heating.
- Ideal for use in all the workshops of self-repair, body shops, motorcycle workshop, carpentry, machine shops, etc ..
- Provided with power at 220 volts and 24 volts at low voltage.
- Rubber covered handle oil-resistant and non-slip, switch protected from dust and moisture, removable hook to hang the lamp, internal protection fuse easily accessible, protection against dust and moisture IP55.
- Available with and without cable 10 meter neoprene very flexible, section 2x1 mm<sup>2</sup>.



Code	Desc.	Supply	Cable
3480002360	330/C	220Volts	Neoprene 10 meters
3480002370	330/S	220 Volts	No
3480002380	331/C	24 Volts	Neoprene 10 meters
3480002390	331/S	24 Volts	No

Spare Parts		
Article	Code	Description
Fluorescent tube replacement 220/24 Volts	3480001500	308/R
Transparent hood parts	3480002400	332/C
Internal electronic circuit parts 24 Volts	3480002410	332/E
Hook parts	3480002361	-
Glass fuse for 220V	3580000200	2A-L20
Glass fuse for 24V	3530000060	500MA-L20

## Portable lamp fluorescent mod.2



- Portable lamp with fluorescent bulb 11W white light.
- Ideal for use in all workshops, self-repair, bodywork, motorcycle workshop, carpentry, etc.
- Beam of light up to eight times longer than ordinary light bulbs.
- Less energy consumption, absence of heating.
- Available with 230V and 24V. Electronic power circuit in the handle, protection switch. Hook hidden adjustable.
- Component handles high strength: the rigid part in PP and glass fiber, soft part Santoprene TPE-V.
- Degree of protection IP 55, when supplied with a cable.
- Available with or without cable (type H05RN-F) to 10 meters, 2x1 sq mm, highly flexible neoprene material. Built in accordance with EN 60598-1, EN 60598-2-8, EN 60335-1.
- Complies with the requirements of the 2006/95 / EC, 2002/95 / EC.
- NB: 24V models must be fed only at 24V; the use with different voltages irreparably damage the power supply circuit of the lamp.

Code	Desc.	Supply	Cable
3480002550	430/230C	230 V	10 meters
3480002555	430/230	230 V	no
3480002560	431/24C	24 V	10 meters
3480002565	431/24	24 V	no

Spare Parts		
Article	Code	Description
Fluorescent tube replacement 230v / 24V	3480001500	308/R
Electronic circuit 230V	3480002556	430/CE
Electronic circuit 24V	3480002566	431/CE
Transparent hood parts	3480002570	432/CT
Hook parts	3480002361	-
Green bezel parts	3480002575	432/G

## Workshop lamps



- Led by a new system Strip exceptional light output.
- The system Strip Led has a light output of 150 traditional LEDs.
- Light beam with an angle of 120 °.
- Reduced power consumption, only 3.5 W and the absence of heating.
- Ergonomic handle, switch protected, oil-resistant casing.
- For workshops, laboratories, construction sites.
- Used as holders for electric reels
- Technical features:
- Dimensions: L 295 mm H 57 mm.
- Angle of light output (°) 120.
- Color Temperature (K) 6500.
- Power consumption (W) 3.5.
- Luminous Flux (lm) 360.
- IP64.
- Power button function anti-rebound.
- Bright and shining light, no heat generation, and with minimal power consumption.
- Available with 230V or 12V DC / AC - 24V DC / AC.
- Cable H05 RN-F. 2x1 mm<sup>2</sup>.
- Switch protected.



Code	Desc.	Supply	Cable
3480002600	530-230/10c	230v	Neoprene 10 mt
3480002610	530-230s	230v	No
3480002620	530-24/10c	12v cc/ca - 24v cc/ca	Neoprene 10 mt
3480002630	530-24s	24v cc/ca - 12v cc/ca	No

Spare Parts		
Article	Code	Description
Transparent cover	3480002640	530/1 black / transparent cover
Hook parts	3480002365	Hook + support

## Rechargeable Lamp 6 SMD LED



- Lamp equipped with 6 powerful LEDs capable of delivering 220lm and 1 front LED
- Folding handle at 180 ° for easy maneuverability
- With magnetic base and retractable hook
- Equipped with indicator x the battery charge status
- The lamp is equipped with 2 magazines: mains 220V and 12V car

Code	Description
3480002690	535-Rechargeable Lamp 6 SMD LED

Tecnical Features	
Recharge time	3,5 h
Autonomy	3 h
Indicator of the battery charge status	Yes
Light flow	220 lm
Front luminance	660 lux a 50 cm
Angle of light output	90°
Magnet	on the basis
Charger	Mains Charger + cigarette lighter plug

Spare Parts	
Code	Description
3480002710	Power supply 110 / 240V - USB + cable
3480002720	Power supply 12V - USB + cable

## Articulated LED lamp Compact Slim



- Led lamp with the rotating body by 180 °
- With magnetic base and retractable hook
- With indicator x the battery charge status
- The small size and the folding body makes the lamp a useful tool for lighting in tight spaces.
- Equipped with 2 magazines: from 220V and 12V car

Code	Description
3480002680	534-rechargeable lamp articulated

Tecnical Features	
Light flow	340 lm
Front luminance	520 lux a 50cm
Indicator of the battery charge status	Yes
Autonomy	3 h
Recharge time	3,5 h
Charger	Mains Charger + cigarette lighter plug
Magnet	On the basis

Spare Parts	
Code	Description
3480002710	Power supply 110 / 240V - USB + cable
3480002720	Power supply 12V - USB + cable



## Portable Rechargeable Lamp 4 SMD LED



- Lamp is equipped with 4 powerful LEDs capable of delivering 220lm
- Folding at 180 degrees for easy maneuverability
- Magnetic base and retractable hook
- Equipped with indicator x the battery charge status
- Equipped with 2 magazines: from 220V and 12V car

Code	Description
3480002700	536-Rechargeable lamp 4 SMD LEDs

Tecnical Features	
Autonomy	4 h
Indicator of the battery charge status	Yes
Light flow	220 lm
Front luminance	450 lux a 50 cm
Magnet	on the basis
Recharge time	3 h
Charger	Mains Charger + cigarette lighter plug

Spare Parts	
Code	Description
3480002710	Power supply 110 / 240V - USB + cable
3480002720	Power supply 12V - USB + cable

## Workshop lamps



**PHILIPS**



- LED Flashlight Penlight.
- Torch LED pocket.
- Practical light source with powerful LED long life.
- Pointer led end.
- Inspection light to all repairers, installers etc ..

Code	Description
3480003000	Led Penligh

Tecnical Features	
Spare batteries	5120001030
Autonomy	8 ore
Tipo di batterie	tipo AAA ( ministilo )N° 3 incluse
Durata led	10.000 ore
Emissione luminosa	90lm
Puntatore a led	20 lumen

## Work lamp rechargeable Led RCH 10 professional PHILIPS



- Lighting cordless tool.
- Compact instrument for workshops ideal for fast and long repairs.
- Illumination intensity 150 LM white light at 6500 K.
- Beam of light at 70 ° with 6 LED-life LED 10,000 h
- It can resist shocks, protection IK07.
- Degree of protection IP54 water and dust-resistant to oils, greases, solvents.
- With retractable hook in the upper part swiveling 360 ° and the magnet on the base.
- Autonomy 5h- charging time 4h lithium-ion battery without memory effect with 1500 mAh capacity.
- Weight 180 g-size length 189 mm-38 mm-63 mm depth.

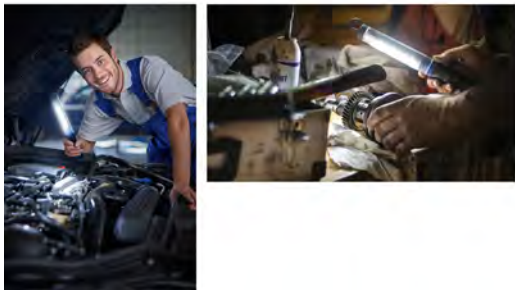

Code	Desc.
3480003080	RCH 10

## Work lamp 72W



- Work lamp 72W, with shell and rubber bumper. Equipped with 2 schuko sockets on the back can be used as extension cables (max 1,500 watts).
- Ideal for all workplaces in the dark or low light.
- Excellent lighting in workshops, for work carried out outside and in the pipeline.
- Suitable for carpenters, fabricators, maintenance personnel, electricians, thermohydraulic, body shops, mechanics, drivers.
- Compared to a halogen lamp does not heat, and has low energy consumption.
- IP54 protection. The lamp is protected against dust and splashing water.
- It can be hung, and used with the stand 348 00 02250 to fit on any type of terrain.
- It may replace the fluorescent tube with burned parts cod. 348 00 02585.
- Equipment: 2 fluorescent tubes of 36W (72W total power); 2 integrated sockets schuko 230V / 16A on the back; 5 m cable type HO7RN-F 3G 1.5 mm neoprene Extra flexible, with excellent resistance to oils and fats, and mechanical stress, with schuko plug.

Code	Desc.	Article
3480002580	442	Work lamp
3480002585	442R	Fluorescent tube replacement 36W

Tecnical Features	
Cable length	5 m
Weight	5 Kg
Dimensions	H285 X L495 X P110
Protection rating	IP 54
Tensione	230V 50Hz

## Replacement lamp cod. 3480002200



Code	Desc.	Article
3480002210	325R	Neon tube replacement

## Stand for work lamp 72W



- Trestle with 3 legs, galvanized steel work lamp 72W cod. 348 00 02580.
- Stable and safe on all surfaces, with height adjustment and swivel.
- Easy to transport, and space saving when closed.

Code	Desc.
3480002250	325C

Technical Features	
Weight	5,42 Kg
Maximum height	210 cm
Minimum height	90 cm

## C+R under bonnet strip light



- Professional Scangrip under bonnet LED strip light to illuminate the complete under bonnet engine area.
- With adjustable telescopic support and padded hooks to protect the vehicle's paintwork.
- It operates by cable or battery.
- Without cable and unhooked from the support, it becomes a large inspection lamp.
- **Technical features;**
- 48 SMD LED
- 500/1000 Lumen
- 1000/2000 Lux
- 3 hours/1.5 hours autonomy.
- 6000 Kelvin
- Supplied with a lithium-ion battery 3.7V/5200mAh
- Recharge time: 4 hours
- 5 metre cable
- Protection rating: IP65
- Dimension: Length 1,027 mm x diameter 25 mm
- Weight: 0.49 kg.

Code	Desc.
3480003120	540



## Line Light C+R lamp



- Powerful Scangrip LED inspection lamp that also operates as a torch.
- Ultraslim, the 25 mm diameter permits inspections in the most inaccessible places.
- Upper spotlight
- It operates by cable or battery.
- Magnetic hook supplied to assist the positioning.
- **Technical features**
- 24 X SMD LED/ 1 X CREE XP G2
- 1300/1500 Lux
- 600/150 Lumen
- 2.5 hours/8 hours autonomy.
- 6000 Kelvin
- Recharge time: 4 hours
- Lithium-ion battery 3.7V/5200mAh
- 5 metre cable
- Protection rating: IP65
- Robust and impermeable
- Dimension: 357 mm x diameter 25 mm
- Weight: 0.27 kg.

Code	Desc.
3480003130	541

## Vega 1500 C+R lamp



- Scangrip professional, powerful LED worklamp
- Emits a powerful diffused light without dazzle.
- Robust, light, impact-resistant structure.
- As opposed to halogen work lamps, it does not create any fire risk inasmuch that LEDs do not produce heat.
- It operates by cable or battery.
- Ideal in all work environments.
- The support is manufactured in epoxy resin painted steel.
- It can be mounted onto the Scangrip tripod, code number 3480003190.
- **Technical features**
- 83 LED
- Step1-Step2
- 750/1500 Lumen
- 1700/3000 lux at 0,5m
- 3 hours/1.5 hours autonomy.
- 6000 Kelvin
- Protection rating: IP54
- Recharge time: 1.5 hours
- 5 metre cable
- Supplied with a lithium-ion battery 11.1V/2600mAh
- Dimensions: 288x103x280 mm
- Weight: 1.6 kg.

Code	Desc.
3480003140	542



## Zone forehead lamp



- Scangrip professional, rechargeable LED forehead lamp.
- Designed for the optimum illumination of the work area.
- Robust and light, it leaves the hands free and permits good visibility of the work area.
- **Technical features**
- COB LED
- Step1-step2
- 110/220 lux at 0,5m
- 60/120 Lumen
- 5 hours/2.5 hours autonomy.
- Lithium-ion battery 3.7V/800mAh
- 6000Kelvin
- Recharge time: 3 hours
- Protection rating: IP30
- 5 hours/2.5 hours autonomy.
- Dimensions: 100x30x35 mm
- Weight: 0.084 kg



Code	Desc.
3480003150	543

## Forehead lamp



- Scangrip professional, rechargeable LED forehead lamp with touchless sensor
- Ideal in all sectors; it illuminates the work area and leaves the hands free to work.
- If set in sensor mode, the lamp can be switched OFF/switched ON by passing the hand in front of the lamp.
- Resistant to dust and weighs only 120 grams.
- **Technical features:**
- COB LED 2W
- Step1-step2
- 300/500 lux at 0,5m
- 100/200 Lumen
- 6 hours/3 hours autonomy.
- 1600 mAh lithium-ion polymer battery
- 6000 Kelvin
- Recharge time: 4 hours
- Protection rating: IP65
- Dimensions: 101x49x35 mm



Code	Desc.
3480003160	544

## Sunmatch 2 lamp



- Scangrip professional LED lamp for comparing colours and the search for small imperfections
- Utilisation sector: Industry and all bodyshops and painting stations
- Possibility of choosing between two intensities of light and two different colour temperatures,
- Keeping the switch pressed for more than 10 seconds, the light changes from warm light to cold light and vice versa.
- After three consecutive minutes of use, an intelligent system reduces the power.
- The COOL WHITE (6500K, 500 lumen) option is ideal for dark coloured surfaces
- The WARM WHITE (4500K, 250 lumen) option is especially useful for bright surfaces
- **Technical features**
- COB LED
- 4500/6500 KELVIN
- 1100/550 lux at 0,5m (step1/step2)
- IP67 protection rating: resistant to water and dust with glass lens resistant to solvents.
- 1 hours/2 hours autonomy
- Recharge time: 4 hours
- Supplied with a lithium-ion battery 3.7V/2600mAh
- Dimensions: 60x190x40 mm
- Weight: 0.30 kg.

Code	Desc.
3480003170	545

## Multimatch lamp 2



- Scangrip LED light to check colours.
- Ideal for the inspection of large surfaces whilst polishing and painting. Light output: 2,500 lumens.
- Utilisation sector: Industry and all bodyshops and painting stations
- It operates by cable or battery.
- Possibility of choosing between two intensities of light and two different colour temperatures,
- The intuitive display signals the battery capacity and the remaining power autonomy.
- **Technical features**
- IP67 protection rating: resistant to water and dust.
- 1 hours/14 hours autonomy
- Recharge time: 2 hours
- 5 metre cable
- Lithium-ion battery 11.1V/4400mAh
- Integrated handle and flexible support to position the lamp to the required illumination angle.
- Dimensions: 235 x 88 x 233 mm
- Weight: 2.2 kgs.
- The support is predisposed for mounting directly on the tripod with wheels: our code. 3480003200 and on tripod code 3480003190.

Code	Desc.
3480003180	546

## Tripod



- Stable and useful accessory for Scangrip worklamps
- Extendable from 1.35 metres to 3 metres thereby permitting the height adjustment required.
- The metal construction makes it stable even when completely extended.
- The electric cable can be fixed to the clip positioned on each leg.
- Thermoplastic fixing ring with an M10 steel pin.
- Maximum load: 10 kgs.
- Base diameter: 1.20 metres
- Weight: 6 kgs.

Code	Desc.
3480003190	547

## Tripod on wheels

9



- Accessory for the mobile positioning of the Scangrip worklamp.
- Permits adjusting the position of the light towards the work area.
- Extendable from 0.7 metre to 1.9 metres.
- Thermoplastic fixing ring with an M10 steel pin.
- Two of the three wheels can be blocked in position.
- Maximum load: 10 kgs.
- Base diameter: 0.8 metres
- Weight: 6 kgs.

Code	Desc.
3480003200	548



## Emergency starter Meccanocar M.2-STARTER 600A



- **Emergency starter** for motorcycles, car, SUV, off road, campers and vans
- **Charger** for all mobile phones (standard connections Micro-USB, Apple 1° and 2° generation), tablet and laptop. Outputs USB 5V from 1A and 2,1A: for all electronic devices with rechargeable batteries (cameras, Go-Pro, etc.). In addition to the equipment for the supply of notebooks than 19V,3,5A the unit is provided with an outlet 12V 10A for powering small devices such as fans, navigation systems, etc..
- **The kit contains:** Main unit with integrated LED lamp fixed and flashing light, car ignition cable, set cables for phone and tablet, notebook set connectors, 12V charger with cigarette lighter socket, 230V charger.
- **System "Smart cable":** The ignition cable has electronic protection unit that protects against short circuit and from an incorrect connection. It also allows start-up of vehicles without battery or battery to 0V.
- With Pin for temperature
- The starter and all accessories are supplied in handy case with zip.
- **IN ORDER TO PROTECT THE CLAMP TO EXCESSIVE OVERHEATING, M2 IS STARTE HAS A TEMPERATURE PROBE THAT PREVENTS THE OPERATION UP TO RESTORE THE PROPER USE OF TEMPERATURE.**
- **PLIER WITH DOUBLE CABLE AND TEETH X MORE CONTACT SURFACE.**
- Product suitable for occasional use, for intensive use is recommended ns. 4430049960 - 976
- **Technical specifications:**
  - Battery with nano lithium polymer (LiCco2)-18000mAh
  - Dimensions 223x80x28,5 mm
  - Weight 720 gr
  - Input 15V-1A
  - Output 5V-1A; 5V-2,1A; 12V-10A; 19V-3,5A;
  - Charging time 6 h
  - Starting power 600A
  - Operating temperature -20 °C/60 °C
  - Shock-resistant aluminum casing



Code	Description
4430057062	M.2-Starter 600A

Spare Parts	
Code	Description
4430057035	DC/DC 12V power supply ( 1 )
4430057040	Charging cable device with 3 connectors ( 2 )
4430057070	Power supply unit 110/240V ( 3 )
4430057082	Cable set with pliers 3 pin x 600A ( 4 )



## Set cavi di ricambio con pinze per 600A

Set cavi con pinze per 600A per modello 4430057060



Code	Description
4430057080	Set cavi con pinze x 600 A

## Emergency Starter 4.0 - 12V 800A



- Ideal for starting motorbikes, cars and vans.
- Practical, easy to handle, light and easy to use.
- Includes charge level indicator.
- Mobile phones and tablets can be recharged using a USB 5V-2A socket.
- Equipped with a fixed or flashing LED lamp.
- **N.B. THE STARTER DOES NOT HAVE A FUSE, BUT GOES INTO PROTECTION MODE IF IT OVERHEATS. IT WILL BE READY TO FUNCTION AGAIN AFTER THREE MINUTES.**



Code	Description
4430058100	Starter 4.0

Technical Features	
Weight	1250 gr
Power output	800 A
Operating temperature	-20° C / 60°C
Dimensions	274 x 165 x 60 mm
Lithium-ion polymer battery capacity	18000 mAh (66.6 Wh)
Output	5V-2A ; 12V starter
Recharge time	6 hours
Input	15V-1A



Spare Parts	
Code	Description
4430057035	DC/DC 12V feeder (1)
4430057070	110V/240V electricity power feeder (2)

## Jump starter model 12V-2400°



- Portable Emergency starter for the setting in motion of motor vehicles with working batteries but exhausted.
- The carcass polyethylene provides extreme durability and excellent resistance to accidental knocks.
- With blue clamp provided with leds to better identify the point of contact.
- Standard: 12v-220v charger automatic, dual cigarette lighter plug.
- The starter is connected to the cigarette lighter, it can be used as the maintainer of memories of all those vehicles which have the circuit of the memories on the cigarette lighter socket.
- With a spare fuse.

### ISTRUZIONI D'USO

Collegare prima la pinza rossa (+) al polo positivo (+) della batteria, quindi collegare la pinza nera (-) ad un punto fisso del telaio possibilmente non verniciato. Non collegare mai al polo negativo (-) della batteria.

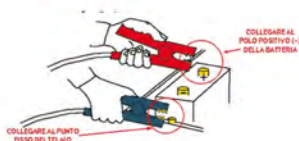

Code	Power	Desc.
4430049960	2400A	976-12V

Tecnical Features	
Weight	10,5 Kg
Dimensions	Width 430 mm - Height 360 mm - Depth 90 mm
Cable clamps	1,5 mt x 25 mm2
Peak current	2400A
Voltaggio	12 Volt
Starting current	800A

Spare Parts	
Code	Description
4430049366	918 - Battery 12V-2400A / H Dimensions 16,7x L18xP7,5cm
4430049630	955 - Double Cable cigarette lighter plug
4430049961	976C - Auto charger 220v-12v
4430049962	Cigarette lighter female
4430049963	976B - Blue pliers with LEDs
4430049964	976R - Red pliers
4430049965	976F - Fuse 300A
4430049966	Voltmeter
4430049967	976P- button for starters
4430050535	male cigarette lighter plug

## Starter 12v - 3100 A peak



N.B. UTILIZZARE IL MORSETTO BATTERIA NEGATIVO QUANDO VIENE ESCLUSA LA BATTERIA O QUANDO QUESTA NON C'E'

**ISTRUZIONI D'USO**  
Collegare prima la pinza rossa (+) al polo positivo (+) della batteria, quindi collegare la pinza blu (-) ad un punto fisso del telaio possibilmente non verniciato. Non collegare mai al polo negativo (-) della batteria.



- AVVIATORE A 12 V-3100 A PICCO - 1200 A IN CONTINUO.
- LUNGHEZZA CAVI 150 Cm.
- CARICATORE AUTOMATICO.
- PROTEZIONE SOVRATENSIONE.
- PESO Kg. 14,5.
- CARCASSA IN POLIETILENE AD ALTA RESISTENZA.

**NB: PRIMA DELL'USO LEGGERE ATTENTAMENTE IL LIBRETTO DI USO E MANUTENZIONE**

- Indicated for the start of any vehicle of any power with or without battery.
- Voltmeter for indicating charge status.
- With automatic charger and cable with double cigarette lighter adapter.
- Overvoltage protection.
- With instruction booklet.
- With a spare fuse
- A EC regulations.

Code	Description
4430050060	985-12V 3100A STARTER

Spare Parts	
Code	Description
4430049961	976 C-AUTO CHARGER. 220V / REPLACEMENT
4430049630	955 CABLE DOUBLE PIN LIGHTER / REPLACEMENT
4430049982	978 B - SPARE CLAMP BLUE C/LED
4430049984	978 R CLAMP RED REPLACEMENT
4430050080	986 F - FUSE REPLACEMENT
4430050075	986B BATTERY REPLACEMENT 248x96x145
4430050535	male cigarette lighter plug

## Jump starter 12-24 volts from 4800 to 2400 A



- Starter portable emergency for the setting in motion of vehicles with working batteries but unloaded, with the possibility of delivering voltages to choice from 12 or 24 volts.
- Suitable for use on all types of means: cars, commercial vehicles, trucks, construction equipment, tractors, boats, etc. useful for mechanics, auto electricians, road transport driver, farms, shipyards, breakdown, etc.
- The shape of the casing allows you to place it in tight spaces or behind the seats of vehicles. The fuse protection against short circuits is easily accessible on the front panel to replace it quickly in case of need.
- Extremely robust: shockproof casing Polyethylene, brass terminals Professional, heavy gauge wiring length of 1.5 meters, plugs for the switching voltage of professional.
- Protected from any kind of operating error or malfunction of the vehicle batteries.
- It equipped as standard with automatic charger with power at 220V-50Hz.
- With a spare fuse.



Code	Desc.
4430049980	978

Spare Parts			
Article	Code	Description	
Automatic charger 220V - 12V	4430049981	978C	
12V battery-2400A / H Dimensions 16.7 L18 P 7.5	4430049366	918BATT	
Blue clamp with LED	4430049982	978B	
Red clamp	4430049984	978R	
Fuse	4430049965	976F	
Yellow plug	4430049986	978S	
Red handle	4430049987	978MA	

Tecnical Features	
Dimensions	Width 500 mm - Height 480 mm - Depth 160 mm
Weight	21 Kg
Reverse polarity alarm	Yes
Uscita a 12 V protetta	16A
Cable clamps	1,5 m x 50 mmq
Voltaggio	12/24 volt
Starting current	1600/800A
Battery charger	12V-1300mA
Peak current	4800/2400 A



## Jump starter combined 12-24 Volts 6200-3100 A



- Combination starter highly professional dedicated to the world of cargo, realized without compromising quality.
- Possibility to supply voltages from 12 to 24V range.
- The voltage selector, 12-24V, is made with sockets anderson, the only able to hold the large amperages generated by this type of starter.
- The heavy gauge wiring completely changed ensure maximum flow of current without overheating.
- The supplied battery charger, allows a full recharge very quickly.
- The special reduced form of the carcass, allows storing it in tight spaces or behind the seats of vehicles. The fuse protection against short circuits is easily accessible on the front panel to replace it quickly in case of need.
- Extremely robust construction: carcass antiurtain polyethylene, brass terminals Professional, heavy gauge wiring length of 1.5 meters, professional plug for direct connection also to vehicles. Protected from any kind of operating error and malfunction of vehicle batteries.
- Suitable for use on any type of medium, in particular where they are needed multiple starts in difficult conditions of industrial vehicles without batteries on board or discharged batteries.
- Aimed at all those working in the fields haulage vehicles: truck drivers, transport companies, sanitation, breakdown services, quarries, construction sites, shipyards, repair and body shops commercial vehicles, agricultural, earthmoving, elettrauto.
- With a spare fuse.

Code	Desc.
4430055000	1120

Technical Features	
Dimensions	W. 520 mm - H. 400 mm - D. 160 mm
Weight	24 Kg
Reverse polarity alarm	Yes
Uscita a 12 V protetta	16A
Cable clamps	1,5mt x 50 mmq
Peak current	6200/3100A
Voltaggio	12/24 Volt
Starting current	2400/1200A

Spare Parts			
Article	Code	Description	
Battery charger	4430049981	978C	
Blue clamp c/led	4430049982	978B	
Red clamp	4430049984	978R	
Fuse	4430050080	986F	
Replacement battery 248x96x145	4430050075	986B	
Yellow plug	4430049986	978S	
Red handle	4430049987	978MA	

## Jump starter 24 volts - 3100 A



- Portable emergency starter for the setting in motion of vehicles powered by voltages from 24 volts.
- Suitable for use on any type of medium: commercial vehicles, trucks, construction equipment, tractors, military vehicles, boats, etc. Useful for mechanics, auto electricians, road transport driver, farms, shipyards, breakdown, etc.
- The shape of the casing allows you to place it in tight spaces or behind the seats of vehicles. The fuse protection against short circuits is easily accessible on the front panel to replace it quickly in case of need.
- Extremely robust: shockproof casing Polyethylene, brass terminals professional, heavy gauge wiring length of 1.5 meters, professional plug for direct connection also to vehicles.
- Protected from any kind of operating error or malfunction of the vehicle batteries. It equipped as standard with automatic charger with power at 220V-50Hz.
- With spare fuse.

Code	Desc.
4430050070	986

Spare Parts		
Article	Code	Description
Battery charger	4430050071	986C
Clamp blue	4430049982	978B
Red clamp	4430049984	978R
Fuse	4430050080	986F
Replacement battery 248x96x145	4430050075	986B

Tecnical Features	
Voltaggio	24 volt
Starting current	1200A
Peak current	3100A
Battery charger	24V-3500mA
Cable clamps	1,5 m x 50 mmq
Uscita a 12 V protetta	16A
Reverse polarity alarm	Si
Weight	24 Kg
Dimensions	Width 500 mm - Height 480 mm - Depth 160 mm

## Avviatore carrellato bomo24-truck



- Avviatore professionale carrellato 24 V-7920 A
- Indicato per l'uso pesante e ripetuto nelle grandi aziende di trasporto, trasporto pubblico urbano, trasporto rifiuti, flotte, carrozzerie e officine industriali.
- Apparecchio affidabile anche in condizioni di temperature estremamente rigide e batterie completamente scariche.
- Dotato di allarme di polarità inversa.

Code	Desc.
4430058120	BOMO24-TRUCK

Technical Features	
Weight	55 Kg
Charger	AC230V 24V/3,5A
Dimensions	47x34x97
Sezione cavi	70 mmq
Lunghezza cavi	180 cm
Corrente di spunto	7920A
Starting current	2640A

Spare Parts		
Article	Code	Description
Pinza blu	4430049982	978B
Pinza rossa	4430049984	978R
Fusibile	4430050080	986F
Caricabatterie	4430050071	986C
Batteria di ricambio	4430058125	1780

## New save memories for 12V vehicles



- Instrument save memories with OBD socket
- By connecting the unit to a battery starter 12V, you can perform the replacement or maintenance of a battery without losing the memories of the vehicle.
- **The practical adapter is also possible to use the n / s M600-600A starter**
- **Features:**
- Fully Automatic
- Cigarette lighter plug protected by glass fuse 5A extent 6,3x32n / s 3530000800
- Automatic Detection System: If the vehicle's electronics enables the device to safeguard memories taken by Obd or function via the cigarette lighter.
- The LED indicators supplied verify that there is the right connection between the Obd taken with the starter and if the battery can be removed without the risk of losing the edge memories
- **INSTRUCTIONS FOR USE:**
- 1. Connect the cigarette lighter plug of the device to the power source at 12V and make sure it is fully inserted. The yellow light # 1 "CONNECTED" should light to confirm the goodness of the connection.
- CAUTION: Do not connect the plug of the device into the cigarette lighter of the vehicle which you intend to replace the battery.
- 2. Fully insert the plug into the OBD diagnostic socket of the vehicle, you must turn on the yellow light # 2 "RELATED" to confirm the connection.
- 3. Verify that the green light comes on # 3, in this case you can proceed to disconnecting battery. If the light is red NOT

Code	Description	Application
4430057600	Save memories x OBD	12V



## Protection apparatus 12 / 24V



- The device reduces the voltage spikes caused by welding, thereby protecting the electronics of the vehicle.
- It connects directly to the batteries at 12 or 24 V.

Code	Desc.
4770001620	162

## Caricabatterie

MECCANOCAR PRESENTA UNA GAMMA RIVOLUZIONARIA DI CARICABATTERIE, NUOVA NELLA TECNOLOGIA E NEGLI INGOMBRI, SIAMO RIUSCITI A RACCHIUDERE IN POCHI CENTIMETRI QUADRI QUANTO DI MEGLIO SI CONOSCA IN FATTO DI CARICABATTERIE PRENDENDO SPUNTO DALLA STESSA TECNOLOGIA UTILIZZATA PER ALIMENTARE I COMPUTER PIU' MODERNI.

RISPETTO AI CARICABATTERIA TRADIZIONALI, QUELLI MECCANOCAR PRODUCONO ENERGIA STABILE SIA NEI VALORI DI TENSIONE CHE DI CORRENTE SENZA PROVOCARE ALCUN DISTURBO ELETTROMAGNETICO.

CON SISTEMA DI MANTENIMENTO AD IMPULSI CHE PERMETTE DI TENERE LA BATTERIA COLLEGATA AL CARICABATTERIE ANCHE PER LUNGI PERIODI, UNO SPECIALE CIRCUITO ELETTRONICO PROVEDE AD INVIARE BREVI IMPULSI QUANDO LA BATTERIA SCENDE AL DI SOTTO DEI 12.9V E MANTENENDO LA BATTERIA COSTANTEMENTE TRA IL 95% E IL 100% DELLA CARICA. IL MODELLO PIU' POTENTE, 4430050530-XS7000 E' DOTATO DEL PROGRAMMA BOOST IN GRADO DI DARE NUOVA VITA ALLE BATTERIE STANCHE GRAZIE AD UN SOVRAVOLTAGGIO ACCURATAMENTE PILOTATO.

TUTTI I MODELLI SONO PROTETTI CONTRO L'INVERSIONE DI POLARITA' E NON PROVOCANO SCINTILLA AL MOMENTO DELLA CONNESSIONE.

### DIAGRAMMI DEI DISTURBI DI CORRENTE

**OGGI**

DISTURBO DI CORRENTE SUL CARICABATTERIE MECCANOCAR

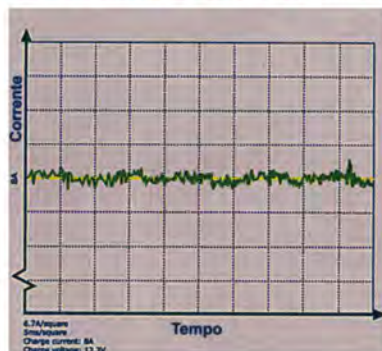

**IERI**

DISTURBO DI CORRENTE SU UN CARICABATTERIE LINEARE

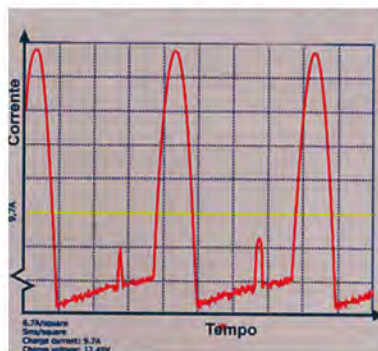

### ESEMPIO DI CARICA



Diagramma di carica XS 3600

## Battery charger Meccanocar XS 0.8A

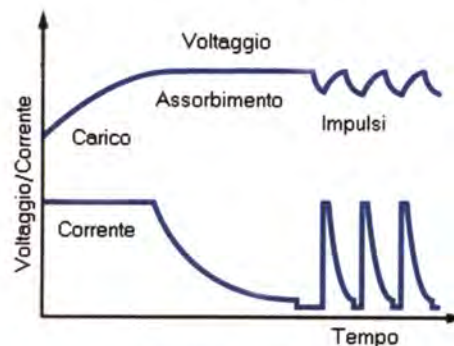

- Chargers of the latest generation for small batteries.
- Fully automatic for optimal charging of all lead-acid.
- Suitable for charging batteries of motorcycles, snowmobiles, quads, lawnmowers.
- It is also indicated for the maintenance of normal sized batteries up to 100Ah.
- Ideal for workshops motorcycles, cars, garages, dealerships.
- A CE.
- 5 year warranty.
- FULLY AUTOMATIC:
  - 1) connect the charger to the battery
  - 2) connect the charger to the wall socket (220V)
  - 3) without ...
- Charging the battery takes place in a completely automatic and takes place in six stages:
  - 1) Desulphation: pulse voltage removes sulphates from the lead plates of the battery restoring the battery capacity
  - 2) Mass: Charging with maximum current up to 80% of the battery capacity
  - 3) Absorption: ready to use, recharge with current decreasing to 100% of the battery capacity
  - 4) Analysis: verify if the battery is able to retain the charge.
  - 5) Float: maintains the battery voltage at maximum level by providing a constant voltage charge (This phase is timed and lasts at least 10 days if the battery is kept in a state of relative rest.)
  - 6) Trickle charge pulsed: keeps the battery at 95-100% capacity. The charger monitors the battery voltage and gives a pulse when necessary to keep it fully charged.
- (This step is activated not before 10 days from the start of the charge, and is designed for the long term maintenance).

Code	Desc.
4430050522	XS 0,8A

Spare Parts			
Code	Description	Model	Photo
4430050537	connettore stagno accendisigari	Con connettore in gomma per accendisigari Ø 12-21 mm.	1
4430050539	connettore stagno batteria	Con connettore in gomma ed occhielli preisolati Ø 6,5 mm.	2

Technical Features	
Tensione minima batteria	2,0V
Tipo di batterie	batterie al piombo-acido 12V
Isolamento	IP65 (a prova di schizzi e polveri)
Battery capacity	1,2-32AH, 100AH per mantenimento
Tensione di ricarica	14,4v
Charging current	Max 0,8A
Tipo di caricabatterie	6 fasi, ciclo di ricarica completamente automatico

## Meccanocar battery charger MXS 3.8 (ex. XS 3600)



- Fully automatic, with three programs:
- 14.4 V / 0.8 to batteries for from 1.2 to 14 A / h.
- 14.4 V / 3.8 to for batteries from 14 to 130 A / h.
- 14.7 V / 3.8 in to the winter cycle or AGM batteries (Acid Glass Mat).
- Cycle constant current - constant voltage.
- Pulse maintenance.
- Automatic reduction of power due to excessive temperature.
- A EC regulations.
- Ideal for all types of modern cars and boats up to 350 Hp.
- Warranty 5 years.
- IP65 (dust proof and splash proof).

Code	Desc.	V Volts	Capacity Ah
4430050525	MXS 3.8	12	1,2 - 130

Technical Features	
Weight	0,5 Kg
Dimensions	165x31x38 mm (LxLxA)
Tensione CA	220-240 VCA, 50-60Hz
Current	0,6A rms
Return current	< 1,3mA
Tensione di ricarica	14,4 V/0,8A - 14,4V/3,8A, 14,7V/ 3,8A
Oscillazione	Max 50 mV rms max 0,05 A rms
Charging current	0,8-3,8 A max
Range di temperatura	da -20°C a +50°C
Isolamento	IP65 (dust proof and splash proof)
Batteries capacity	da 1,2 a 130 Ah

## Meccanocar battery charger MXS 7.0



- Fully automatic, with four programs: 14.4V / 7A for standard batteries, 14.7V / 7A for winter cycle or AGM batteries, power supply 13.6V / 7A, boost 16V / 1.5A.
- Cycle diagnosis - constant current - constant voltage-pulse maintenance.
- The way power allows replacement of the battery of the vehicle without the loss of memories.
- The boost mode allows the recovery of batteries also subjected to excessive discharge.
- Automatic reduction of power due to excessive temperature.
- Supplied in carrying case with instructions.
- A CE
- Ideal for batteries of 12V trucks, industrial vehicles and construction machines, vessels up to 800 hp.
- \* To Back current drain is defined as the current that returns from the battery if the charger is connected to the battery without connecting the power cord. This value is on average 30 times lower than in conventional chargers.
- \*\* The quality of the current and voltage is very important. a linear charger produces a current with a high ripple that heats up the battery and makes the positive electrode age prematurely. A high value of the oscillation can also harm other equipment connected to the battery. The chargers Meccanocar allow to obtain high quality current low ripple. There is no need to disconnect the battery from the vehicle to protect the electronics.

Code	Desc.	V Volts	Capacity Ah
4430050530	XS7000	12	14-225

Tecnical Features	
Weight	0,8 Kg
Isolamento	IP65 (dust proof and splash proof)
Batteries capacity	da 14 a 225 Ah
Oscillazione**	Max 150 mV rms max 0,3A rms
Charging current	7 A max
Range di temperatura	da -20°C a +50°C
Tensione CA	220-240 VCA, 50-60Hz
Current	0,9 A rms
Tensione di ricarica	14,4 V, 14,7V, 13,6V continuous, 16 V Boost
Dimensions	191x89x48 mm (LxLxA)
Return current*	< 3 mA



## Battery charger Meccanocar 24V



- Fully automatic, with 3 programs.
- Cycle diagnosis, constant current, constant voltage, pulse maintenance.
- The program allows power to change the batteries and to supply loads without losing the memories. You can also protect the control units during welding operations.
- The program also lets you boost the recovery of discharged batteries where excessive power is reduced automatically when the temperature increases.
- \* To Back current drain is defined as the current that returns from the battery if the charger is connected to the battery without connecting the power cord. This value is on average 30 times lower than in conventional chargers.
- \*\* The quality of the current and voltage is very important. A linear charger produces a high ripple current that heats up the battery and makes the positive electrode age prematurely. A high value of the oscillation can also harm other equipment connected to the battery. The chargers Meccanocar allow to obtain high quality current low ripple. There is no need to disconnect the battery from the vehicle.

Code	Desc.	Capacity Ah
4430050532	Multi XT14000	28-500

Tecnical Features	
Weight	1,4 Kg
Dimensions	233x128x64 mm (LxLxA)
Batteries capacity	from 35 to 225 Ah
Isolamento	IP 44 (outdoor use)
Charging current	14 A max
Range di temperatura	from -20°C to +50°C
Tensione di ricarica	from 28.8 to 31.0 V, which varies as a function of temperature.
Oscillazione**	Max 50 mV rms max 0,13A rms
Tensione CA	220-240 VCA, 50-60Hz
Return current*	14 mA
Current	3,0 A rms

## Connectors battery charger Meccanocar



- Connectors cigarette lighter socket and direct battery connection for connecting electronic caribatterie Meccanocar XS800 and XS3600.
- The connectors allow for cigarette lighter to recharge the batteries using the special sockets present on the media, like BMW motorcycles.
- The connectors for direct connection to the battery allow to quickly change the availability by a connection to the battery without removing fairings motorcycle or covers on the car.
- Complete with cable of adequate length of about 30 cm.

Code	Description	Model	Photo
4430050535	Cigarette lighter connector	Old model with plastic connector for cigarette lighter Ø 12-21 mm.	1
4430050537	Waterproof connector cigarette lighter	New model with rubber connector for cigarette lighter Ø 12-21 mm.	2
4430050539	Waterproof connector battery	New model with rubber connector and pre-insulated eyelet Ø 6,5 mm.	3



## Furniture workshop and equipping vans

Carts e toolholders . . . . .	pag. 1246	Easel and motorcycle lift. . . . .	pag. 1303
Workshop furniture . . . . .	pag. 1270	Lifting and transport systems. . . . .	pag. 1308
Van equipment . . . . .	pag. 1289	Ladders and scaffolding . . . . .	pag. 1326



### Cart 7 drawers



- Tool holder trolley with 7 drawers.
- With Centralised locking.
- 4 small drawers format 576x415x60mm.
- 2 drawers average size 576x415x130mm.
- 1 trolley 576x415x200mm large format.
- With integrated carry handles for not having protruding organs.
- With perforated panel toolholder + port spray cans on one side.
- Upper floor with carpet anti-oil.
- With wheels diam.125mm.
- Structure green RAL6029 shiny, drawers gray RAL7011.
- Capacity Shopping 400 kg, 45 kg capacity drawers

Code	Desc.
4700007600	797

Spare Parts	
Code	Description
4700000780	Kit 4 wheels diam.125mm
4700007645	801 / S lock for drawers with folding key
4700007640	801- Couple telescopic guides L: 400mm

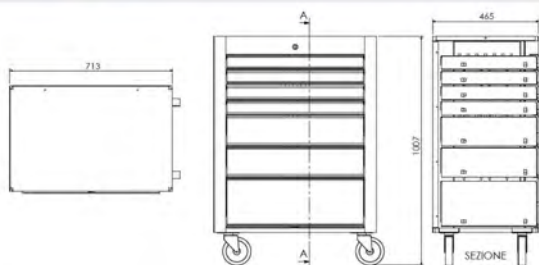

### Cart 4 drawers



- Tool holder trolley with 4 drawers. with central locking.
- 3 small drawers format 576x415x60mm.
- 1 medium size drawer 576x415x130mm.
- With integrated carry handles for not having protruding organs. with perforated panel toolholder + port spray cans on one side.
- Upper floor with carpet anti-oil with wheels diam.125mm.
- Structure green RAL6029 shiny, drawers gray RAL7011.
- Capacity Shopping 400 kg, 45 kg capacity drawers.

Code	Desc.
4700007610	798

Spare Parts	
Code	Description
4700000780	Kit 4 wheels diam.125mm
4700007645	801 / S lock for drawers with folding key
4700007640	801- Couple telescopic guides L: 400mm

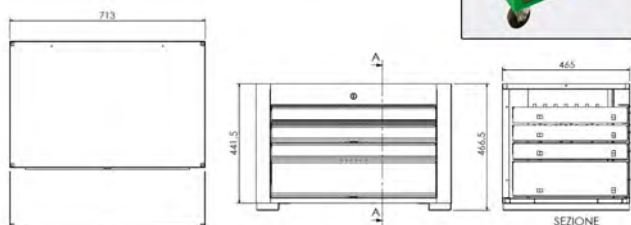

## Assortimento utensili 3 cassettei -121 utensili

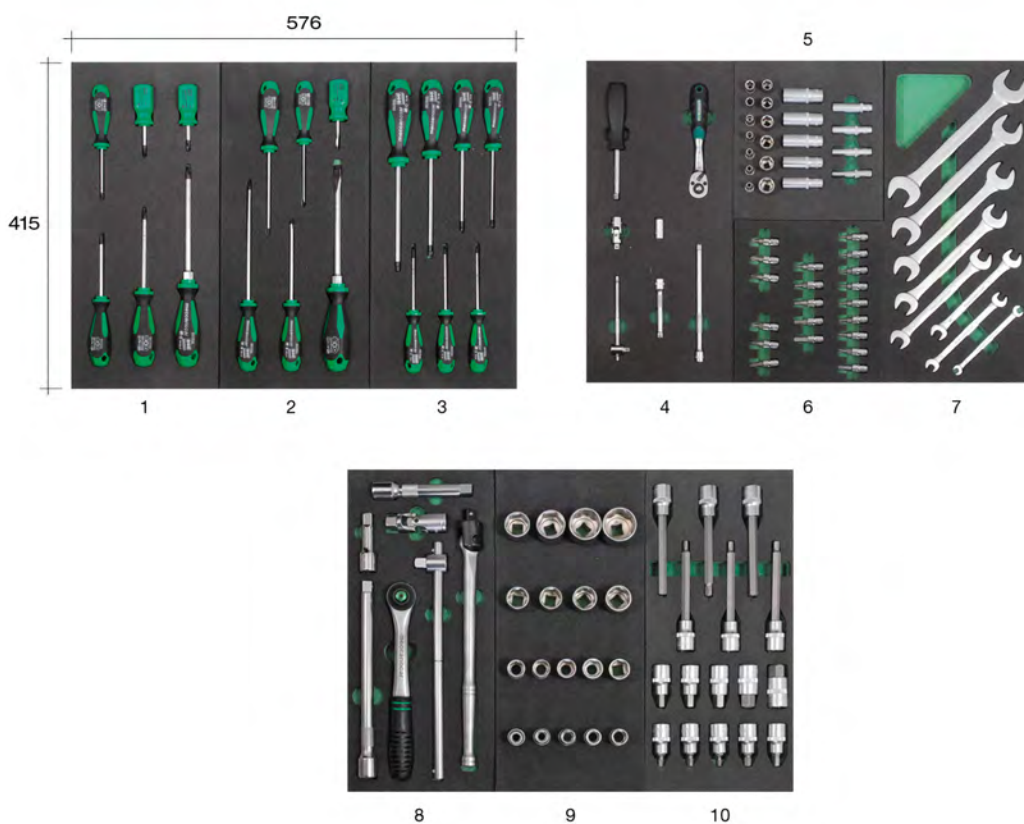

- In polietilene a bassa densità espanso

Code	Description
420000010	10-kit 121 pezzi

**Composizione:**

CODICE	DESCRIZIONE	N° pezzi	Foto
4200004001	4001-accessori per bussole 1/4"	7	4
4200004002	4002-bussole esagonali c+1 1/4"	22	5
4200004004	4004-bussole corte profili vari 1/4"	20	6
4200004010	4010-accessori per bussole 1/2"	7	8
4200004011	4011-bussole esagonali corte 1/2"	18	9
4200004016	4016-bussole torx c+1 1/2"	20	10
4200004039	4039-cacciaviti a croce ph	6	1
4200004040	4040-cacciaviti a taglio	6	2
4200004041	4041-cacciaviti torx	7	3
4200004024	4024-chiavi fisse da 6x7 a 20x22	8	7



## Assortimento utensili 4 cassetti -163 utensili

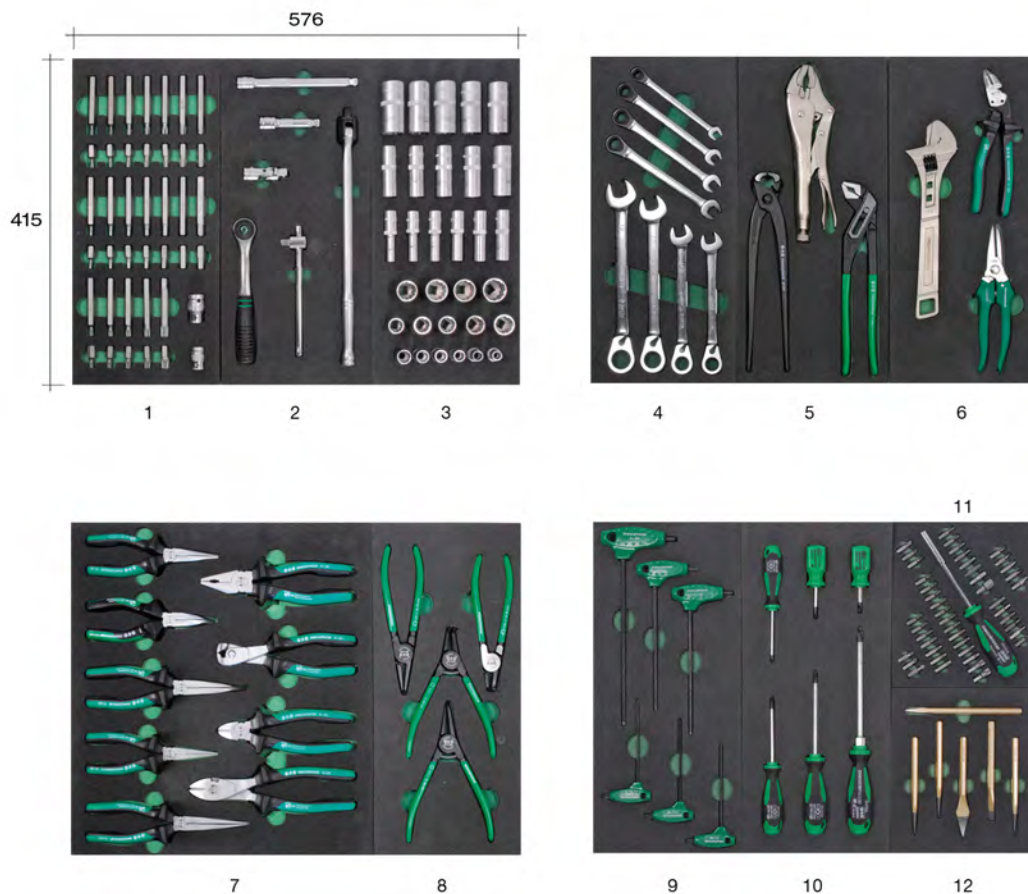

- In polietilene a bassa densità espanso
- Indicato per MOTO

Code	Description
420000025	25M kit moto 4 cassetti 163 utensili

### Composizione:

CODICE	DESCRIZIONE	N° pezzi	Foto
4200004005	4005-Accessori per bussole 3/8"	6	2
4200004009	4009-Bussole poligonali C+L attacco 3/8"	31	3
4200004043	4043-Bits vari profili +2 bussole 3/8"+1/2"	40	1
4200004028	4028-Chiavi combinate a cricchetto 8-19	8	4
4200004039	4039-cacciaviti a croce ph	6	10
4200004033	4033-chiavi maschio esagonali L da 2 a 6	6	9
4200004023	4023-pinze seeger x interni e esterni	4	8
4200004036	4036-pinze miste	3	5
4200004047	4047-scalpelli punteruolo e punzoni	6	12
4200004042	4042-bits + porta bits attacco 1/4"	41	11
4200004035	4035-pinze	9	7
4200004038	4038-pinza-cesoia e chiave inglese	3	6

## Assortimento utensili 6 cassettei -192 utensili

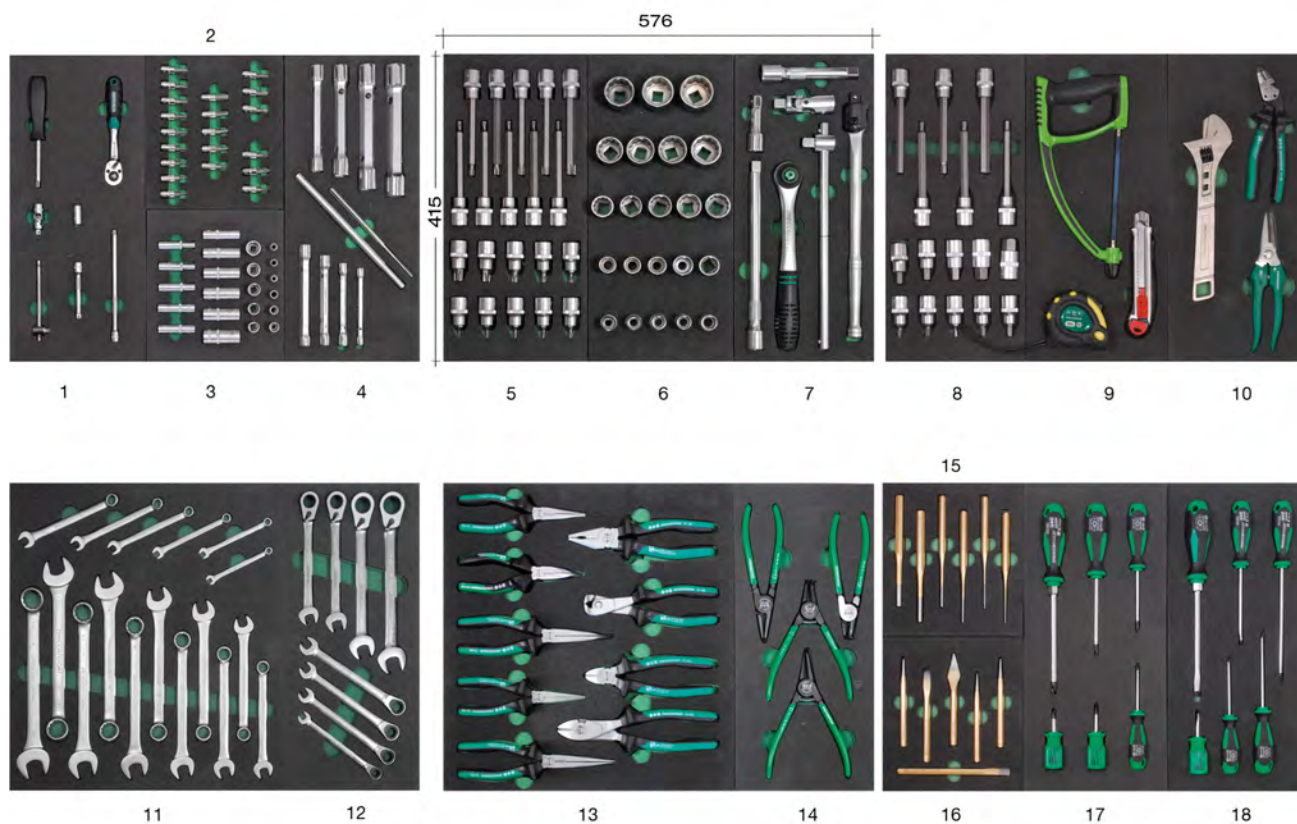

- In polietilene a bassa densità espanso

Code	Description
420000026	26 kit 6 cassettei 192 utensili

**Composizione:**

CODICE	DESCRIZIONE	N° pezzi	Foto
4200004001	4001-accessori per bussole 1/4"	7	1
4200004003	4003-bussole poligonali corte e lunghe attacco 1/4"	22	3
4200004004	4004-bussole corte profili vari 1/4"	20	2
4200004010	4010-accessori per bussole 1/2"	7	7
4200004013	4013-bussole poligonali corte 1/2"	22	6
4200004015	4015-bussole esagonali corte e lunghe 1/2"	16	8
4200004016	4016-bussole torx corte+lunghe 1/2"	20	5
4200004026	4026- chiavi combinate 6-22	17	11
4200004028	4028-chiavi combinate a cricchetto 8-19	8	12
4200004032	4032-chiavi a tubo pesanti 6x7-20x22	10	4
4200004039	4039-termo cacciaviti a croce PH	6	17
4200004040	4040-cacciaviti a taglio	6	18
4200004035	4035-pinze	9	13
4200004038	4038-pinza-cesoia e chiave inglese	3	10
4200004047	4047-scalpelli punteruolo e punzoni	6	16
4200004049	4049-cacciaspine	6	15
4200004044	4044-cutter-flessometro -seghetto	3	9
4200004023	4023-pinze seeger x interni e esterni	4	14



## Assortimento utensili 7 cassetti -143 utensili

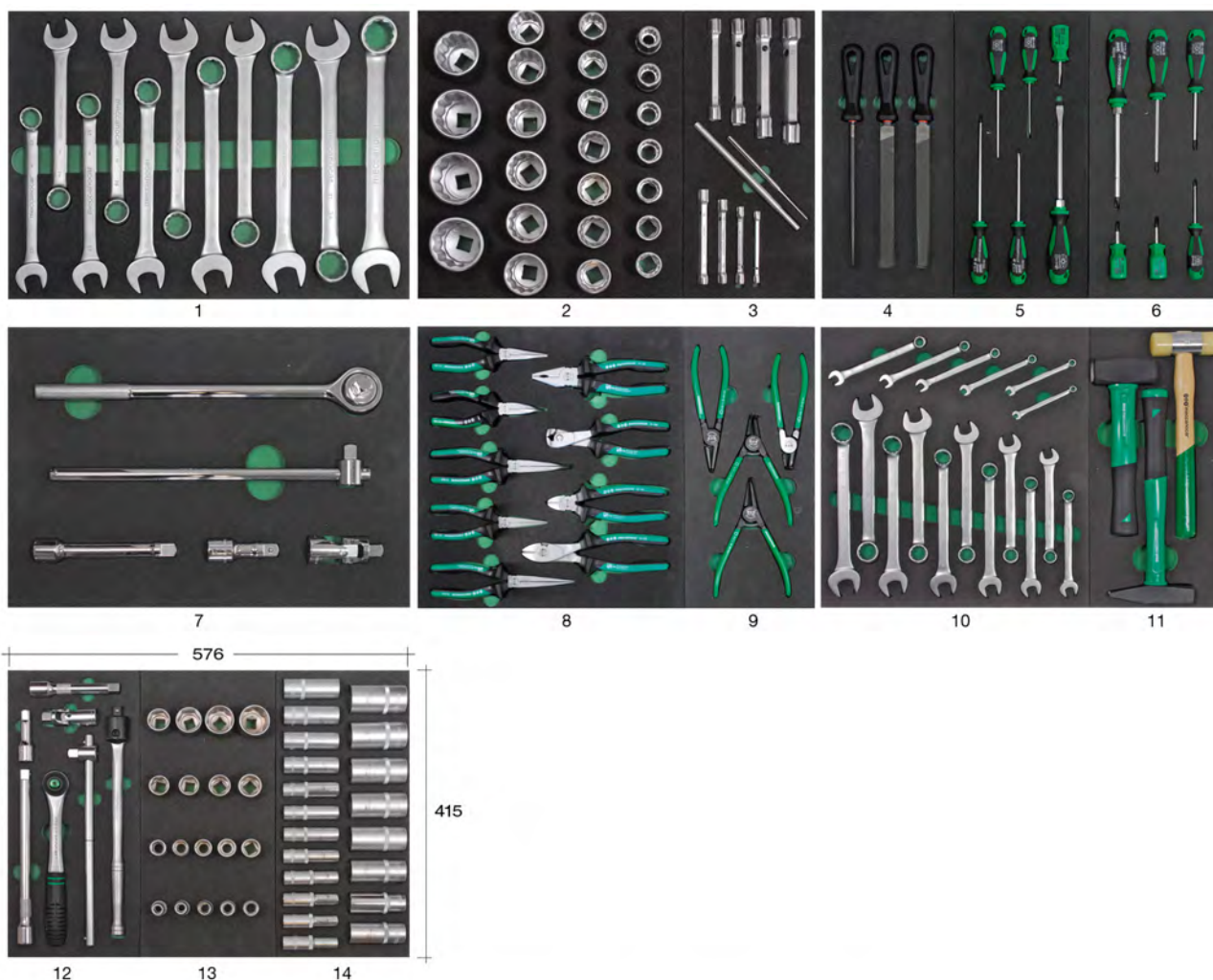

- In polietilene a bassa densità espanso
- Indicato per veicoli industriali

Code	Description
420000027	27C kit cargo 7 cassetti 143 utensili

### Composizione:

CODICE	DESCRIZIONE	N° pezzi	Foto
4200004010	4010-accessori per bussole 1/2"	7	12
4200004022	4022-bussole poligonali corte attacco 3/4"	24	2
4200004020	4020-accessori per bussole attacco 3/4"	5	7
4200004012	4012-bussole esagonali lunghe attacco 1/2"	20	14
4200004026	4026- chiavi combinate 6-22	17	10
4200004027	4027-chiavi combinate 23-36	11	1
4200004032	4032-chiavi a tubo pesanti 6x7-20x22	10	3
4200004039	4039-cacciaviti a croce ph	6	6
4200004040	4040-cacciaviti a taglio	6	5
4200004011	4011-bussole esagonali corte 1/2"	18	13
4200004035	4035-pinze	9	8
4200004045	4045-lime per meccanica	3	4
4200004023	4023-pinze seeger x interni e esterni	4	9
4200004037	4037-martelli e mazzuola	3	11

## Trolley model base 6 drawers



- Trolley model base 6 drawers
- Worktop with protective ribbed carpet
- With central locking
- Equipped with 4 different sizes of drawers that fit to contain tools of various sizes
- Equipped with 4 wheels d.125 of which 2 fixed and 2 pivoting with brake
- **DIMENSIONS:**
- Width: 680mm
- Height: 925mm
- Depth: 405mm
- Capacity: Kg150

Code	Description	N° cassetti
4700010500	Trolley 6 drawers	6

Spare Parts	
Code	Description
4700010502	Replacement lock
4700010507	Pair of guides with bearings



CASSETTO	LARGH. mm	LUNGH. mm	ALTEZZA mm	PORTATA CASSETTO Kg
1	570	370	65	20
2	570	370	65	20
3	570	370	90	20
4	570	370	90	20
5	570	370	115	20
6	570	370	165	20

## Carrello premium 7 cassetti



- Carrello portautensili 7 cassetti versione Premium il cui design è ispirato al mondo racing nasce per essere capiente, solido ma anche compatto e pratico.
- Piano di lavoro in abs con alloggiamenti porta minuterie.
- Struttura in lamiera ultra resistente verniciata in nero a polvere epossidica antigraffio e resistente ai prodotti chimici.
- Cassetti di colore grigio con maniglie in alluminio e predisposizione per strisce per l'indicazione del contenuto.
- Pratiche tasche laterali porta bombolette e utensili.
- Chiusura centralizzata e chiusura su ogni singolo cassetto.
- Dotato di 4 ruote d.125 di cui 2 fisse e 2 piroettanti con freno.
- **DIMENSIONI CARRELLO:** Base 698 (con manico 715) - Altezza 910 mm - Larghezza 475 mm - Portata 240 kg

Code	Description	N° cassetti
4700010300	Carrello premium	7

Spare Parts	
Code	Description
4700010306	Replacement lock
4700010308	Pair of fixed wheels d.125
4700010309	Pair of swivel wheels with brake d.125
4700010310	Pair of guides with bearings



CASSETTO	LARGH. mm	LUNGH. mm	ALTEZZA mm	PORTATA CASSETTO Kg
1	532	406	43	25
2	532	406	43	25
3	532	406	58	30
4	532	406	58	30
5	532	406	58	30
6	532	406	58	30
7	532	406	170	30



## Carrello premium 8 cassetti



- Carrello portautensili modello premium a 8 cassetti.
- Piano di lavoro in abs con alloggiamenti porta minuterie
- Struttura in lamiera ultra resistente verniciata in nero a polvere epossidica antigraffio e resistente ai prodotti chimici.
- Cassetti di colore grigio con maniglie in alluminio con predisposizione per strisce per l'indicazione del contenuto.
- Con chiusura centralizzata e chiusura su ogni singolo cassetto.
- Dotato di protezioni sui 4 lati contro gli urti accidentali.
- 4 ruote d.125 di cui 2 fisse e 2 piroettanti con freno.
- **DIMENSIONI CARRELLO:**
- Base 650 (con manico 690) - Altezza 980 mm - Larghezza 485 mm
- Portata 265 kg

Code	Description	N° cassetti
4700010400	Carrello premium	8

Spare Parts	
Code	Description
4700010402	Replacement lock
4700010308	Pair of fixed wheels d.125
4700010309	Pair of swivel wheels with brake d.125
4700010310	Pair of guides with bearings



CASSETTO	LARGH. mm	LUNGH. mm	ALTEZZA mm	PORTATA CASSETTO Kg
1	532	411	60	25
2	532	411	60	25
3	532	411	60	25
4	532	411	60	25
5	532	411	60	25
6	532	411	108	30
7	532	411	108	30
8	532	411	108	30

## Kit base 4 cassettei 95 utensili

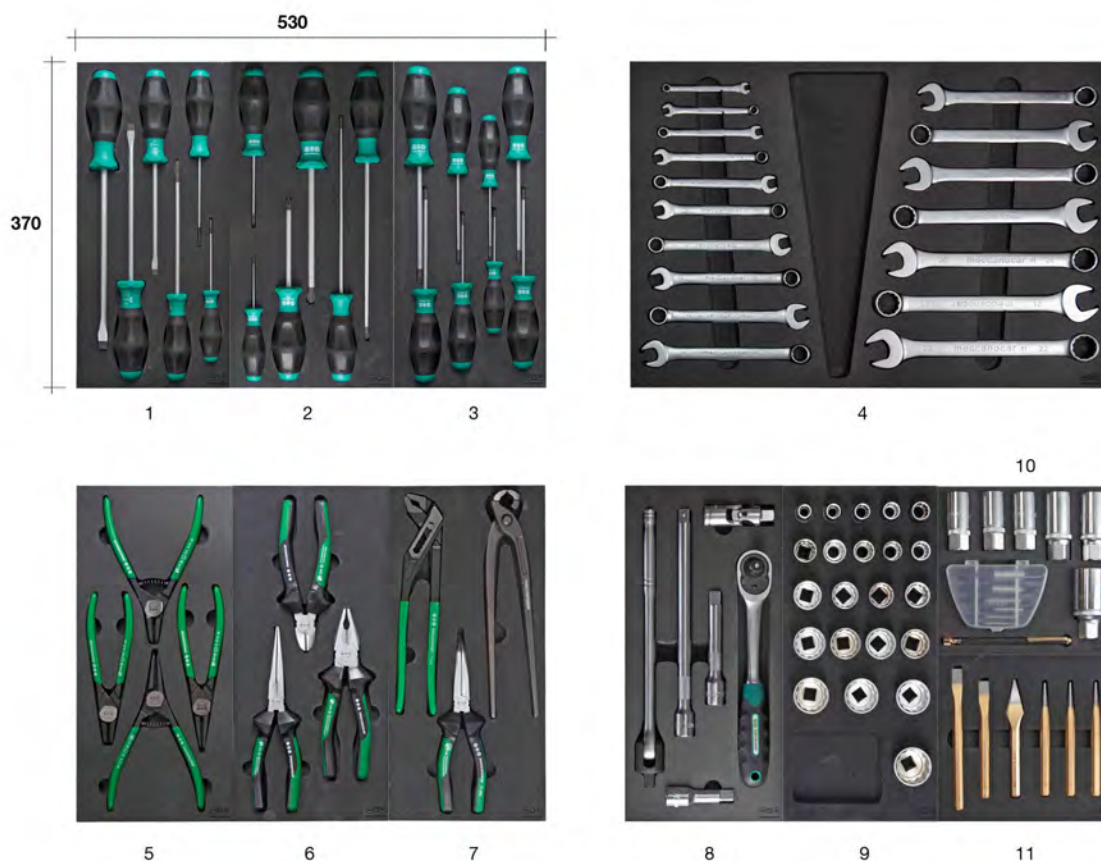

- Kit utensili per nuovi carrelli Meccanocar
- Per cassettei formato 530x370mm

Code	Description
420000074	74-4 kit base 4 cassettei 95 pz

### Contenuto:

CODICE	DESCRIZIONE	PEZZI	FOTO
4200005006	5006-TERMO CACCIAVITI A TAGLIO	6	1
4200005007	5007-TERMO CACCIAVITI CROCE PH	6	2
4200005008	5008-TERMO CACCIAVITI TORX	8	3
4200005023	5023-TER.CH.COMBIN.DA MIS 6 A 22	17	4
4200005003	5003-TER.P.SEEGER X AN.EST.INT.	4	5
4200005001	5001-TERMO 3 PINZE	3	6
4200005005	5005-TERMO PINZE+TENAGLIA	3	7
4200005016	5016-TERMO ACCES.X BUS.DA 1/2"	6	8
4200005019	5019-TERMO BUS.POL. 1/2"CORTE	22	9
4200005033	5033-TERMO ESTRATTORI	13	10
4200005027	5027-TERMO PUNT.PUNZONI	6	11

## Kit Moto 5 cassettei 205 utensili



- Kit utensili per nuovi carrelli Meccanocar
- Per cassettei formato 530x370mm

Code	Description
420000075	75-5 kit moto 5 cassettei 205 pz

### Contenuto:

CODICE	DESCRIZIONE	PEZZI	FOTO
4200005023	5023-TER.CH.COMBIN.DA MIS 6 A 22	17	1
4200005013	5013-TER.BITS3/8+2 BUS.POR.BITS	40	2
4200005016	5016-TERMO ACCES.X BUS.DA1/2"	6	3
4200005035	5035-TERMO BUS.ESA.1/2"CORTE	18	4
4200005033	5033-TERMO ESTRATTORI	13	5
4200005006	5006-TERMO CACCIAVITI A TAGLIO	6	6
4200005007	5007-TERMO CACCIAVITI GROCE PH	6	7
4200005008	5008-TERMO CACCIAVITI TORX	8	8
4200005029	5029-TERMO ACCES.XBUS.DA1/4"	7	9
4200005027	5027-TERMO PUNT.PUNZONI	6	10
4200005030	5030-TER.1/4" BUS.COR.VARI PROF.	53	11
4200005028	5028-TERMO CACCIASPINE	6	12
4200005012	5012-TER.CH.CO.CRIC.MIS.DA 8 A 19	8	13
4200005001	5001-TERMO 3 PINZE	3	14
4200005005	5005-TERMO PINZE+TENAGLIA	3	15
4200005003	5003-TER.P.SEEGER X AN.EST.INT.	4	16



## Kit Professional 6 cassettei 139 utensili

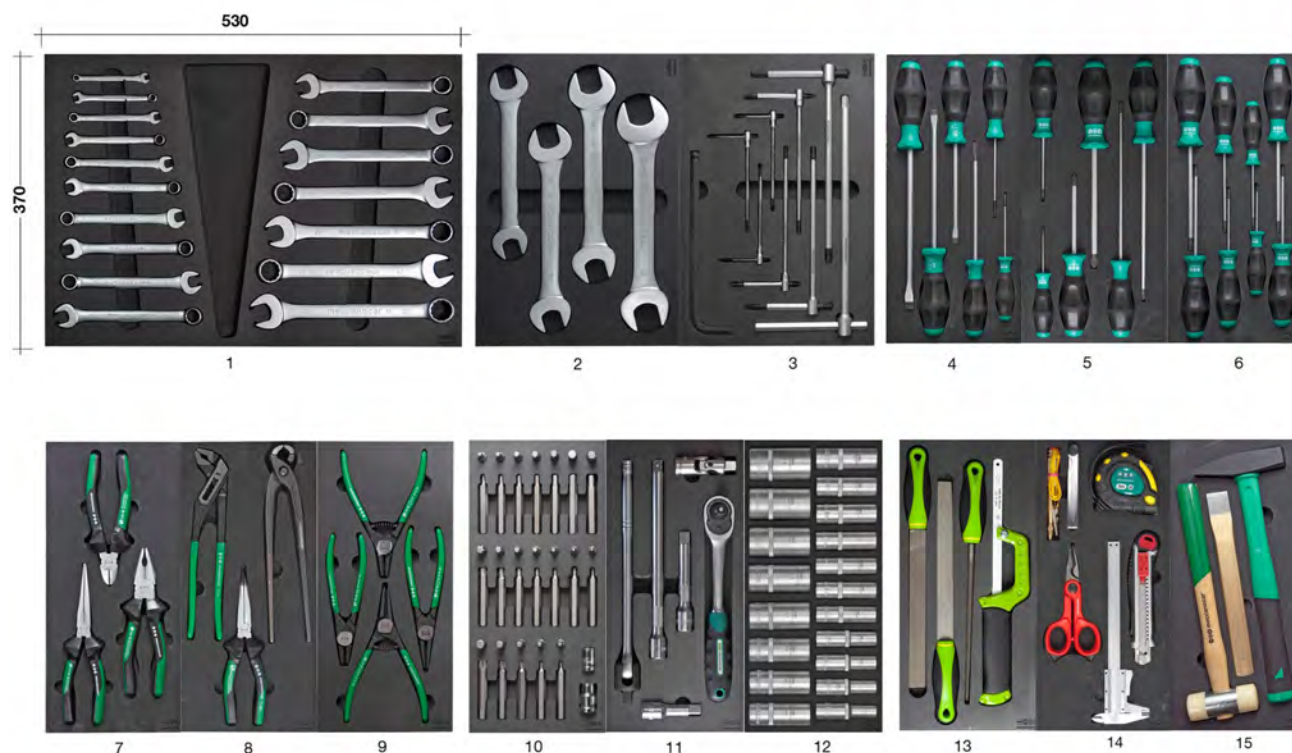

- Kit utensili per nuovi carrelli Meccanocar
- Per cassettei formato 530x370mm

Code	Description
420000076	420000076 76-6 kit porofessional 139pz

### Contenuto:

CODICE	DESCRIZIONE	PEZZI	FOTO
4200005023	5023-TER.CH.COMBIN.DA MIS 6 A 22	17	1
4200005021	5021-TERMO CH.FISSE 21X23-30X32	4	2
4200005000	5000-TERMO CHIAVI A 3 T.+M12	9	3
4200005006	5006-TERMO CACCIAVITI A TAG	6	4
4200005007	5007-TERMO CACCIAVITI CROCE PH	6	5
4200005008	5008-TERMO CACCIAVITI TORX	8	6
4200005001	5001-TERMO 3 PINZE	3	7
4200005005	5005-TERMO PINZE+TENAGLIA	3	8
4200005003	5003-TER.P.SEEGER X AN.EST.INT.	4	9
4200005013	5013-TER.BITS3/8+2 BUS.POR.BITS	40	10
4200005016	5016-TERMO ACCES.X BUS.DA1/2"	6	11
4200005017	5017-TERMO BUS.ESA.1/2"LUNGHE	19	12
4200005009	5009-TERMO LIME + IMP.LAME SEGHET	4	13
4200005010	5010-TERMO UTENSILI VARI	6	14
4200005004	5004-TERMO MARTELLI+SCALPELLO	3	15



## Kit Cargo 7 cassettei 151 utensili

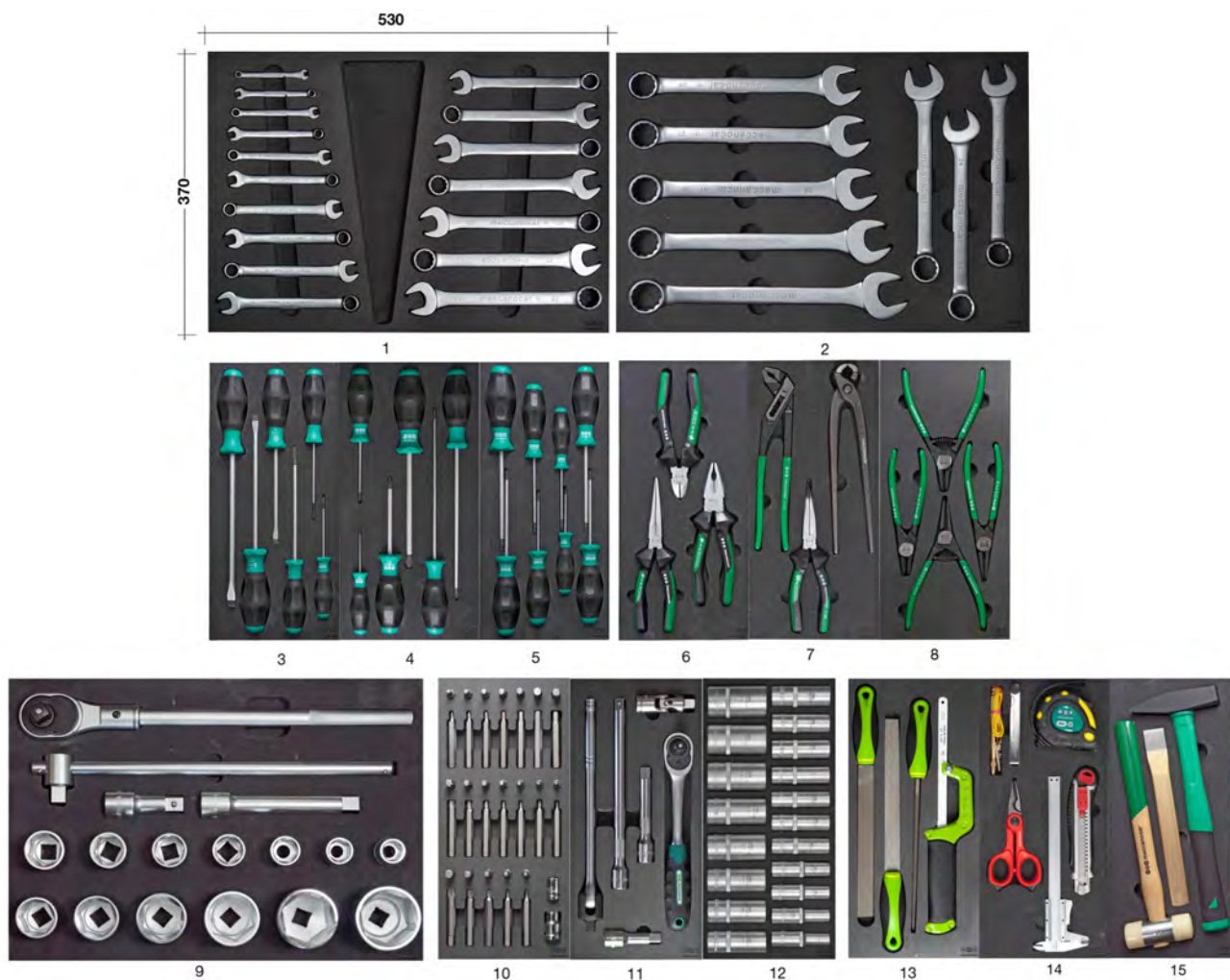

- Kit utensili per nuovi carrelli Meccanocar
- Per cassettei formato 530x370mm

Code	Description
420000077	77-7 kit cargo 7 cassettei 151 pz

### Contenuto:

CODICE	DESCRIZIONE	PEZZI	FOTO
4200005023	5023-TER.CH.COMBIN.DA MIS 6 A 22	17	1
4200005022	5022-TER.CH.COMBIN.DA MIS 23A32	8	2
4200005006	5006-TERMO CACCIAVITI A TAG	6	3
4200005007	5007-TERMO CACCIAVITI GROCE PH	6	4
4200005008	5008-TERMO CACCIAVITI TORX	8	5
4200005001	5001-TERMO 3 PINZE	3	6
4200005005	5005-TERMO PINZE+TENAGLIA	3	7
4200005003	5003-TER.P.SEEGER X AN.EST.INT.	4	8
4200005031	5031-TERMO ACCES.+BUS.DA3/4"	17	9
4200005013	5013-TER.BITS3/8+2 BUS.POR.BITS	40	10
4200005016	5016-TERMO ACCES.X BUS.DA1/2"	6	11
4200005017	5017-TERMO BUS.ESA.1/2"LUNGHE	19	12
4200005009	5009-TERMO LIME + IMP.LAME SEGHET	4	13
4200005010	5010-TERMO UTENSILI VARI	6	14
4200005004	5004-TERMO MARTELLI+SCALPELLO	3	15

## Workshop trolley 3 levels



- Worktops covered with rubber mats.
- 2 swivel wheels.
- Shockproof polypropylene handle.
- Max Capacity 200, weight 16 kg.
- To be assembled.

Code	Desc.
4700000100	2200

Spare Parts	
Code	Description
4700000105	2200 / R WHEELS PARTS DIAM 80 MM
4700000106	2200/100RWHEELS PARTS DIAM 100 MM

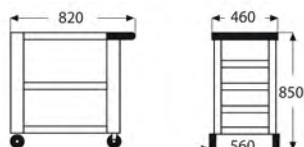

## Utility cart



- Cart multi use with folding handle.
- 4 Wheel diameter 125mm to be able to move on all surfaces.
- The folding handle allows the user to store the cart also under a shelf once used
- Sheet painted green ral 6029 shiny
- For workshops, warehouses, laboratories, etc. ..
- Reach 250 kg.

Code	Desc.
4700007650	803

Spare Parts	
Code	Description
4700000780	Kit 4 wheels diameter 125mm

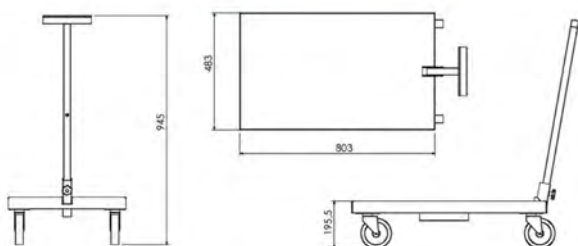

### Cart for drums of 200 Kg



- Cart for handling drums of 200 kg, is particularly suitable for automotive, industrial vehicles and earth moving.
- Robust Carbon steel, with pump support, support hose and coupling stops cover.
- Complete with 4 wheels; 2 turning plate  $\varnothing$  200 mm. and 2 solid rubber with hub bearings  $\varnothing$  250 mm.
- Dimensions: height 960mm, width 740mm, depth 960mm.
- Large working surface (630x660 mm).

Code	Desc.	Weight Kg.
4700001700	2500	41

### Grids brings drums

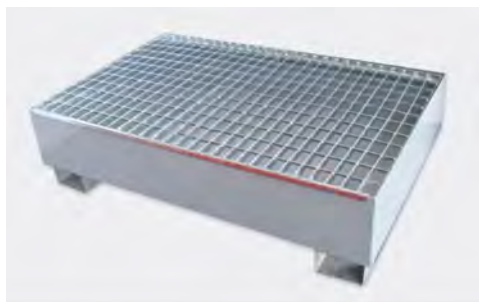

- For workshops.
- Grids brings drums are essential for the storage and handling of hazardous products for the pollution of soil and groundwater.
- The steel tanks are used for storage of most of the chemicals, oil etc ..
- Not suitable for products acids, alkalis and solvents.
- Important: the collection tank must be able to contain 1 / 3 of the volume stored and must not be less than the capacity of the largest container.
- If storage takes place in the area of protection of ground water the tub must contain 100% of the product.

Code	Description
4430055902	1532-Grid for 2 drums

Tecnical Features	
Weight kg	54
Portata Lt	205
Dimensions A+B+C mm	1210 x 740 x 330

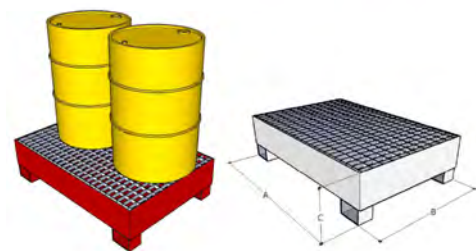

10

### Drums support



- Support saddle steel 2 drums with a capacity of 200 kg.
- For horizontal placement of the drums.

Code	Description
4430055912	1534- Drums support

Tecnical Features	
Weight kg	19,5
Portata Lt	600
Dimensions A+B+C mm	1180 x 600 x 380

## Grab for lifting of steel drums 200 kg



- Tool used with lift systems like our hydraulic crane 470 03000-470 00 00 08050.
- Max Capacity 350.



Code	Description
4700007560	791-Clamp raises drums of 200 Kg

## Tool holders technical suitcases



- Suitcase model professional in ABS with aluminum frame.
- With ergonomic handle.
- Double key lock.
- With 4 rubber feet on metal reinforcement.

### TECHNICAL FEATURES:

- 1 document wallet with pockets gripper.
- 1 flap at PPL PVC coated with 6 rows of elastic loops + 1 panel with 3 rows of elastic loops.
- 2 cassettes for small parts, one with a bit holder.
- 1 bath internal modular with three separators that can hold even a cordless screwdriver.



Code	Desc.	Dimensions mm	Weight Kg.
4700003400	2540	490x400x195	4,5



### Tool holders technical suitcases



- Professional aluminum suitcase model.
- The ultimate expression of elegance combined with maximum strength.
- Professional suitcase with chrome handle with soft grip.
- Double key lock.
- 8 rubber feet.
- 3 sturdy hinges.
- With hooks for the shoulder strap.
- Reinforced with steel frame.

**TECHNICAL FEATURES:**

- 1 document wallet with pockets gripper.
- 1 flap at PPL PVC coated with 6 rows of elastic loops + 1 panel with 3 rows of elastic loops.
- 2 boxes for small parts 1 with bit holder.
- 1 bath internal modular with three separators that can hold even a cordless screwdriver.
- 1 belt strap.

Code	Desc.	Dimensions mm	Weight Kg.
4700003450	2541	500x400x220	7

### Tool holders technical suitcases



- shockproof ABS case;
- **Field of use:** maintenance workers, electricians and plumbers, repairmen electronic equipment.
- **Key features:**
- External profile aluminum, black rubber seals shock.
- Mortise locks with lock and further Central Lock number combination.
- Ergonomic handle with return spring.
- 2 fiber panels with 3 rows of elastic loops.

Code	Desc.	Measures internal mm	Measures external mm	Weight Kg.
4700004900	2588	475x355x180	490x400x180	4,8

## Tool boxes 5 compartments

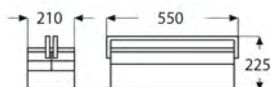

- Long model.
- Allows the insertion of the keys "T" long.
- Painted sheet metal.
- Double handle for a better opening.
- Weight 6.5 kg.

Code	Desc.
4700001100	2230/5L

## Modular toolboxes



- Professional toolboxes in shockproof ABS
- Excellent for carrying manual tools or electro-tools.
- With the use of blisters, they are perfect as small part holder.
- Modular with quick release system.
- It is enough to put a box on the other, even only with one hand, to automatically stack them thanks to the side hooks.
- The handle goes back into the lid seat and slides on rails to balance the weight.
- The internal part is sealed for protecting the content against moisture and rain.

10

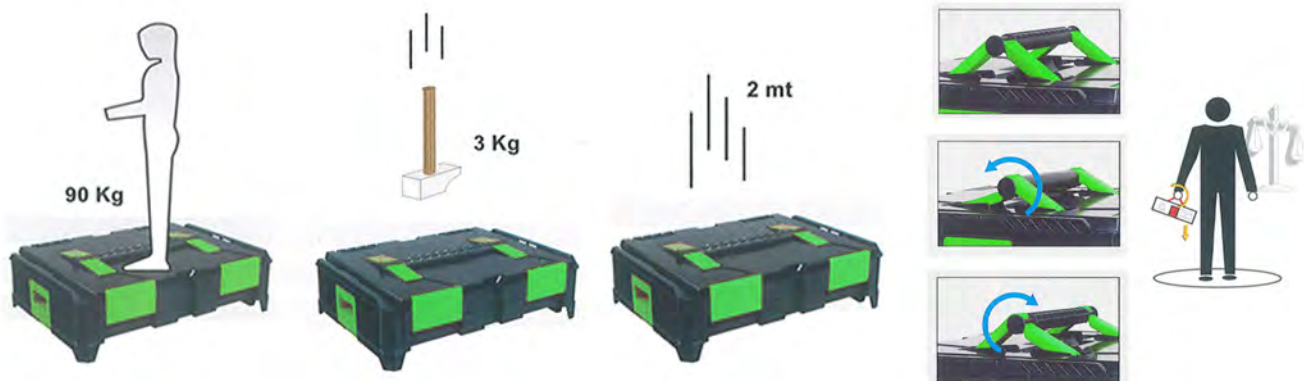

Code	Description	D. int. mm	D. est. mm	Weight Kg.	Capacity Lt
3980004600	Toolbox SC1	400x300x80h	464x335x142h	2,15	9,6
3980004610	Toolbox SC2	400x300x150h	464x335x212h	2,60	18
3980004620	Toolbox SC3	400x300x312h	464x335x362h	3,75	37,4

## Cassetta sc3 con due pannelli interni con elastici



- Panels with elastic bands for positioning the manual tools.

Code	Description	Conf.	D. est. mm
3980004630	Toolbox SC3P22	Due pannelli con elastici	464x335x362h

## Blister in thermo-plastic material for toolbox SC1



- Note: the toolbox SC1 features already a sponge mounted on the plug bottom to allow a precise closure with the blisters.
- Blister mm. 396 x 296 x 70

Code	Description	Photo
3980004640	Blister with 5 internal dividers for SC1	1
3980004650	Blister with 10 internal dividers for SC1	2
3980004660	Blister with 18 internal dividers for SC1	3
3980004670	Blister with 12 internal modular dividers for SC1	4
3980004680	Sponge for bottom 400X300X150 for SC1, SC2, SC3.	5



## Metal base on wheels for moving the SC toolboxes.



- The SC toolboxes locks on the base with a simple click, as on another toolbox.
- It can be used only on smooth surfaces.

Code	Description	Dim. mm
3980004690	SC/CW Base with wheels	470x340x100 ruote incluse ( di cui 2 con freno)

## Polypropylene carrying cases 13"



- Handy and convenient cases.
- Various sizes for many different requirements.
- Suitable for keeping grouped and carrying tools and small parts.

Code	Description	Dim. mm	Characteristics
3980004700	Case 13"	335x150x145h	2 small part holders on the lid + 1 Single holder inside

## Polypropylene carrying cases 16"



- Handy and convenient cases.
- Various sizes for many different requirements.
- Suitable for keeping grouped and carrying tools and small parts.

Code	Description	Dim. mm	Characteristics
3980004710	Case 16"	415x215x200h	2 small part holders on the lid + 1 Single holder inside

## Polypropylene carrying cases 20"



- Handy and convenient cases.
- Various sizes for many different requirements.
- Suitable for keeping grouped and carrying tools and small parts.

Code	Description	Dim. mm	Characteristics
3980004720	Case 20"	530x290x280h	Small part holder on the lid + 1 Single holder inside

## Polypropylene carrying cases 70/12



- Case without internal dividers
- That can be used for tools, drills, electric screwdrivers, grinders, and any power tools.

Code	Description	Dim. mm
3980004730	70/12 Case	375x285x130h

## Bag for plumbers / electricians



- Leather Bag.
- Length 55 cm.
- With belt strap.

Code	Desc.
4720007800	189

## Scabbard drill



- Sheath polyester capacious to contain a cordless drill. It equipped with 4 slot external brings tips or bits, 1 buckle horizontal tool holder or tape.
- Intended Use: termidraulico, electrical, maintenance, window fitters, carpenters, workshops, emergency medical, municipal utilities.
- Suitable for all operators who need to work with your hands free from obstruction, and have the tools always at hand. Practical for those working at heights.
- Attached to the belt of the operator.
- Seams resistant and well-appointed, provide additional strength to the scabbard.



Code	Desc.	Width dimension/depth/height
4700006830	2730	170x95x345 mm

## Belt tools satchel



- Belt pouch polyester fabric, made up of: 4 pockets for tools, 2 slots bits or bits, 2 metal hooks.
- Intended Use: plumbing and heating, electrical, maintenance, window fitters, carpenters, workshops, emergency medical, municipal utilities.
- Suitable for all those operators who need to work with your hands free from obstruction, and have the tools always at hand. Practical for those working at heights.
- Capacious, sturdy and not cumbersome.
- Seams resistant and well finished.

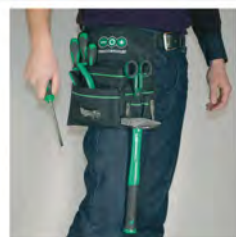

Code	Desc.	Dimensione mm larghezza/altezza
4700006820	2720	265x270

## Tool holders chair



- Sedia richiudibile in tessuto poliestere e struttura di sostegno in alluminio.
- Settore di utilizzo: termidraulico, elettrico, manutenzione, serramentisti, carpenterie, officine, soccorso stradale, aziende municipalizzate.
- Leggera, pratica e robusta. Permette all'operatore di lavorare nel comfort in qualsiasi posto.
- 2 spaziose tasche laterali esterne.
- 2 capienti vani laterali con chiusura a zip, di cui: uno con 6 tasche interne aperte e porta utensili estraibile (foto A); l'altro con 9 tasche aperte interne.
- Facile trasporto grazie alla fibbia regolabile a tracolla, e l'impugnatura spugnata.
- Cuciture resistenti e ben rifinite.
- Portata della seduta max 150kg.

Code	Desc.	Width dimension/depth/height
4700006840	2740	300x340x340 mm

## Tool bag



- Practical, handy tool bag
- Main open compartment with 10 external pockets.
- 600D polyester bag (cordura type) reinforced with fixed metal handle
- Max transport weight 20 kg
- Size cm 38x22x28h

Code	Description
4700030100	Tool bag



### XL Tool bag



- Large size tool bag.
- Main wide compartment.
- Four inner pockets plus sixteen tool compartments.
- Forty external pockets of different sizes for screwdrivers and tools.
- Metal handle with slip-resistant handle rotating on pins.
- Padded shoulder strap for carrying.
- Made of 600D polyester (cordura type).
- Max transport weight 20 kg
- Size cm 51x28x36h

Code	Description
4700030110	XL Tool bag

### Tool case



- Practical case in 600D polyester (cordura type).
- With handle and shoulder strap for easy carrying.
- Opening with zips on both sides.
- Various inner pockets for positioning different equipment.
- Inner panel with elastics for screwdrivers and/or tools.
- This case can be used also for carrying computers or diagnostics equipment.
- Dimensions mm: L425XH355XP160.

Code	Description
4700030120	Tool case

10

### Tool backpack



- Tool backpacks in 600D polyester (cordura type).
- Suitable for carrying instruments and tools for any kind of work.
- The 24 inner and side pockets allow to distribute the weight and track down the items easily.
- Upper slip-resistant handle.
- Strong rubber base.
- Comfortable padded adjustable straps.
- Size mm: L370xH430xP200.

Code	Description
4700030130	Tool backpack

## XXL Tool backpack



- Large size tool backpack in 1680D polyester.
- Suitable for carrying tools and equipment for any kind of work.
- Inner panel with double-sided tool holder.
- The various inner/side pockets allow to insert and carry different kinds of equipment.
- Furthermore, it is equipped with pockets with zip for personal objects and documents.
- Large upper padded carrying handle.
- Strong rubber base.
- Reflective strip for a better visibility at night.
- Comfortable padded adjustable straps with quality belts.
- Max transport weight 20 kg
- Size mm: L400xH550xP200.

Code	Description
4700030140	XXL Tool backpack

## Metal shelving Meccanocar line "Taurus"



ESEMPIO DI SCAFFALATURA MONTATA ED ALLESTITA

- Metal shelving, equipped with small parts for mounting, robust, versatile, allows you to maximize space in any work environment.
- Painting green RAL 6029 gloss.
- Metal shelving in line Taurus supplied assembled, comprising:
  - 2 modules based art. 4700003325-2525 (A).
  - 1 module mat varied art. 470 00 0335-2527 (B).
  - 1 module p. chemical aerosol art. 00 470 03340-2528 (C).
  - 1 module c / drawers art. 470 00 03370-2534 (D).
  - 1 module for silicone cartridges art. 00 470 03345-2529 (G).
  - 1 module for small boxes art. 00 470 03330-2526 (F).
  - 1 module to a plan art. 00 470 03360-2532 (E).
  - Assembled Size: l1220mm x x p350mm h1680mm.

Code	Desc.
4700003320	2524

## Base Module



- With galvanized hardware for mounting.

Code	Desc.	Dimensions mm
4700003325	2525	L610xP350xH180

## Module for hardware box



- With galvanized hardware for mounting.
- Movable dividers.

Code	Desc.	Dimensions <i>mm</i>
4700003330	2526	L610xP350xH500

## Module for all kinds of material shot with slatted



- With galvanized hardware for mounting.

Code	Desc.	Dimensions <i>mm</i>
4700003335	2527	L610xP350xH500

## Module chemical (aerosol) - 70mm widths partitions



- With galvanized hardware for mounting.

Code	Desc.	Dimensions <i>mm</i>
4700003340	2528	L610xP350xH500



### Module cartridge type sealants - dividers width. 50 mm



- With galvanized hardware for mounting.

Code	Desc.	Dimensions mm
4700003345	2529	L610xP350xH500

### Module for electric cable reels with the insertion of Article. 357 B4 00200 to 14001



- With galvanized hardware for mounting.

Code	Desc.	Dimensions mm
4700003355	2531	L610xP350xH500

10

### Module 1 plan



- With galvanized hardware for mounting.

Code	Desc.	Dimensions mm
4700003360	2532	L610xP350xH500

## Caisse 4 Drawer Tool

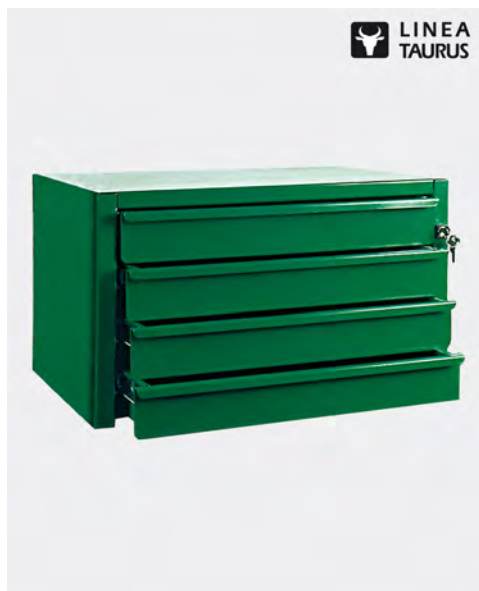

- With centralized closing.
- Drawer height: 55 mm.
- Drawer cm 30x39 mm

Code	Desc.	Dimensions <i>mm</i>
4700003365	2533	L485xP345xH280

## Module 4 drawer tool box



- The module consists of the module to a plane over a chest of 4 drawers - joined together.
- With galvanized hardware for mounting.

Code	Desc.	Dimensions <i>mm</i>
4700003370	2534	L610xP350xH500

## Magnetic label holders



- Precut magnetic label holders.
- Addressed to all types of customers
- Suitable to label in a simple and rapid shelving, cabinets and any type of metallic container.
- Allow the application and the immediate replacement of bar codes, writings and codes relating to products in the warehouse.
- The label holders are made of soft magnetic rubber with profile magnetized from one side, which allows an effective fastening system, preventing any damage to the surfaces and facilitating the operations of application and replacement of the fingers.
- Possibility of applying the double-sided tape (cod 4060700400-4060700050-4060700100-4060700120) for fixing the magnet to the supports non-metallic.
- Provided of white card on which customize the labels, and a transparent PVC protective and dust.

Code	Desc.	Measures L x H mm
4700007100	360	120 X 20
4700007105	365	120 X 25
4700007110	370	120 X 30
4700007120	380	120 X 40

## Drawers assembled door hardware model Madia



- System consists of removable trays tilt opening.
- Suitable for those who want to order and efficiency in the workplace (workshops, coachwork, shops, etc ..).
- The system includes accessories for the creation of wall shelves and floor with stops to prevent unintentional opening of the drawers.
- Drawers, available in different sizes, are realized in transparent plastic materials unbreakable tabs team for product classification.
- A complete storage system by 60 cm.
- Example of the structure, several other possibilities exist.

10

## Cupboard 9 drawers



- Drawer dimensions: l 56, p 43, h 64/47 mm.

Code	Description	Length total mm	P	H
3980004400	M1-9 drawers	600	96	112

### Cupboard 6 drawers



- Drawer dimensions: l 88, p 65, h 98/70 mm.

Code	Description	Length total mm	P	H
3980004405	M2-6 drawers			

### Cupboard 5 drawers



- Drawer dimensions: l 108, p 98, h 148/107 mm.

Code	Description	Length total mm	P	H
3980004410	M3-5 drawers	600	140	168

### Cupboard 4 drawers



- Drawer dimensions: l 138, p 127 h 190/134 mm.

Code	Description	Length total mm	P	H
3980004415	M4-4 drawers	600	178	206

### Cupboard 3 drawers



- Drawer dimensions: l 180, p 145 h 220/161 mm.

Code	Description	Length total mm	P	H
3980004420	M5-3 drawers	600	210	242

### Latches for cupboard



- Material: metal.

Code	Desc.	Tipologia
3980004430	FM1	Freeze for kneading trough 9 drawers
3980004435	FM2	Arrêt pour cupboard 6 tiroirs
3980004440	FM3	Arrêt pour cupboard 5 tiroirs
3980004445	FM4	Arrêt pour cupboard 4 tiroirs
3980004450	FM5	Arrêt pour cupboard 3 tiroirs

### Guides for hanging cupboards



- Practical and sturdy frame for wall mounting.
- Made of welded sheet metal and oven-painted with epoxy powder.
- It equipped with 4 holes on the back for convenient wall mounting.
- It provided no cupboards.

Code	Desc.	LxHxP mm
3980004460	MP125	600 x 1000 x 40



## Exhibitor with base cupboards



- Practical and sturdy frame exhibitor base.
- Made of welded sheet metal and oven-painted with epoxy powder.
- It delivered dismantled, with screws provided for assembly.
- It provided no cupboards.

Code	Desc.	Dimensions mm
3980004470	MP195	L 600 xP x H 325 1950 (1850 usable space)

## Casket for bands and various small parts



- Plastic.
- Container with limit switch.
- With 12 containers and carrying handle.

Code	Desc.	Dimensions mm
3980001500	198	355x460x170

## Small part holder



- Small part holder with movable dividers
- Supplied with dividers
- Dimensions mm 400x305x62h

Code	Description
3980004740	4515- Case with movable dividers
3980001910	ABH6-Spare dividers

## Polypropylene container assortments - empty case for removable compartments



- Unbreakable polypropylene container.
- For removable compartments.
- Transparent cover.
- The special lid hinge guaranteed not dump parts, even of very small dimensions in phase transport the briefcase.

Code	Desc.	Dimensions mm
3980001900	ABH4	H 57xL 340xP 265

## Containers assortments Polypropylene transparent removable

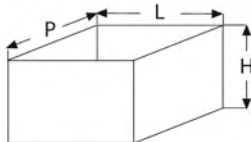

Code	Desc.	Dimensions mm	Filling % bag
3980002000	A 78	H 45xL 80xP 110	1/8
3980002100	A 816	H 45xL 80xP 55	1/16
3980002200	A 916	H 45xL 40xP 110	1/16
3980002300	A 932	H 45xL 40xP 55	1/32

## Cases for assortments with 12 or 18 fixed compartments



- Unbreakable polypropylene container.
- Fixed compartments, transparent lids.

Code	Desc.	Dimensions mm
3980001700	200	H 32xL 175xP 145
3980001800	201	H 42xL 240xP 195

### Impact polystyrene tray

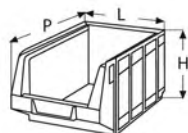

- Polystyrene green.
- Maxime resistance to oils and greases
- Dual system of vertical side follow suit.

Code	Desc.	Dimensions <i>mm</i>
4000000100	2 K	L 108xP 167xH 75
4000000200	3 K	L 151xP 237xH 126
4000000300	4 K	L 213xP 350xH 164
4000000400	5 K	L 310xP 490xH 190

### Perforated panel keychain

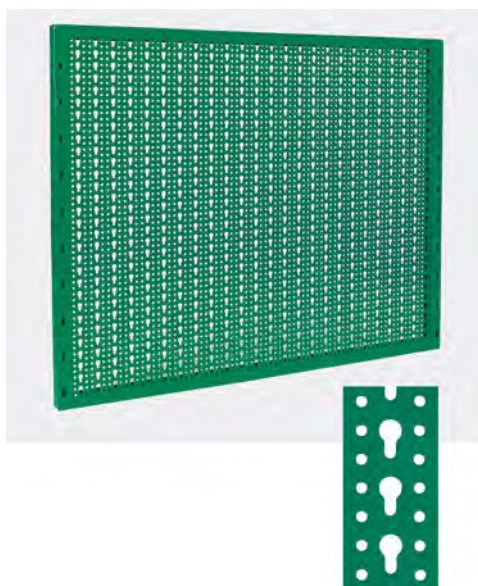

- Double drilling system.
- Hooks for engagement with a slot.
- Painted sheet metal.
- Green RAL 6029 gloss.
- To see hooks n / s Article 443-442.

Code	Desc.	Dimensions <i>mm</i>
4430039600	441	1000x800
4430039610	441-2	2000x800

## Ganci portachiavi per pannelli forati



Code	Desc.	Characteristics
4430039700	442-1	STRAIGHT
4430039710	442-2	CURVED
4430039720	442-3	CLAMP
4430039730	442-4	STRAIGHT SHORT
4430039765	442-6	AT HOLE
4430039770	442-7	AT GLASS
4430039775	442-8	AT PAN

## Key clip for perforated panels



- Hooks with attachment slots.
- ABS support.

Code	Desc.	Characteristics
4430039740	442-5-L10	STRAIGHT L 100
4430039750	442-5-L15	STRAIGHT L 150
4430039760	442-5-L20	STRAIGHT L 200



### Kit plastic hooks for panels



- Hook Kits mount slotted

Code	Desc.	N. Pieces
4430039780	442 KIT	50

**Contenuto kit**

CODICE	DESCRIZIONE	Q.tà
443 00 39700	DIRITTO	N° 10
443 00 39710	CURVO	N° 10
443 00 39720	A PINZA	N° 10
443 00 39730	DIRITTO CORTO	N° 10
443 00 39765	A OCCHIELLO	N° 10

### Pegboard keychain



- Perforated plate (4 holes  $\varnothing$ ) wheelbase mm22.
- With removable shelf.
- Color: Grey.
- To see our art hooks 443-432.

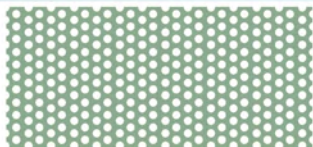

Code	Desc.	Dimensions mm
4430038500	431	1000x850

10

### Single hook for perforated panels



- For our panel coloré gray.
- Hooks made of galvanized steel.
- 22 mm wheelbase.

Code	Description	Length mm
4430038600	432-5	60
4430038700	432-10	120
4430038900	432-0 - WITH RING	-

## Metal storage shelf for small parts



- Painted sheet, color gray.
- Dividers made of galvanized sheet.
- Cardboard labels.

Code	Desc.	Boxes	Dimensions mm
4430039200	435	36	600x600x12
4430039300	436	114	600x1800x12

## Safe Lock Meccanocar | Canvas to entry gates



- Safety lock for gates.
- Made entirely of tempered steel.
- It equipped with patented safety lock with drill protection and anti-bumping.
- Nickel-plating treatment to ensure the corrosion resistance.
- Piston locking protected.
- Piston locking fracture calibrated.
- Cut resistant.
- Easy to use.
- Easy to install.
- Complete with two steel brackets to be welded to the two perforated gate leaves.
- Supplied several pieces with the same key.
- Supplied with three copies of keys.

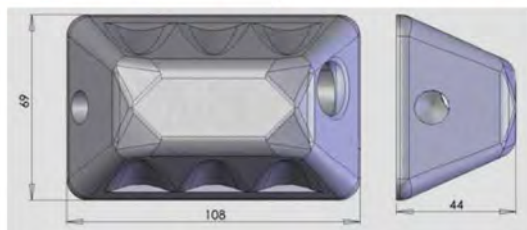

Code	Desc.
4700008000	90-01

## Meccanocar Lock Safe II Canvas for shutters



- Security lock for rolling.
- The safest system for closing intrusion of your shutter.
- Lock made entirely of tempered steel.
- It equipped with patented safety lock with drill protection and anti-bumping.
- Nickel-plating treatment to ensure the corrosion resistance.
- Piston locking protected.
- Piston locking fracture calibrated.
- Cut resistant.
- Easy to use.
- Easy to install.
- It comes with two removable head nuts for fixing and related caps to seal the installation holes.
- Supplied several pieces with the same key.
- Supplied with three keys and corresponding card to any requests for copies.
- We recommend the use of two threaded rods M12 length. 200/250 mm.per fixing.

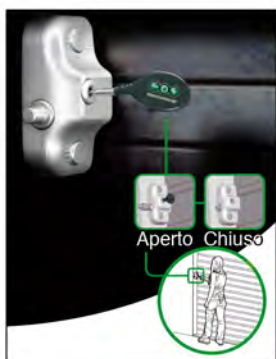
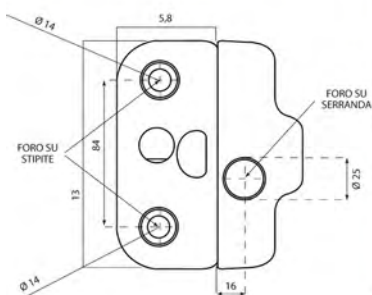

Code	Desc.
4700008010	90-02

## Lock Meccanocar Van safety device for commercial vehicles loading location



- Safety device for all types of commercial vehicles, usable both on rear doors that on those side-down.
- Useful to all those who have the need to protect the contents of your van es. electricians, plumbers, couriers, vans roadside assistance etc ..
- Corazza tempered steel with chemical nickel coating which ensures the corrosion resistance.
- Possibility of use with two locking functions, manual or automatic.
- It is sold individually and twice with the same key.
- Supplied with three keys and corresponding card to any requests for copies.

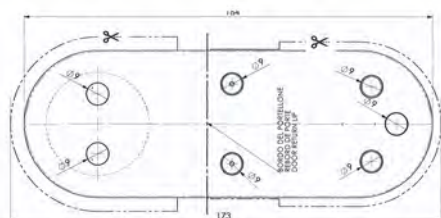

Code	Description
4700008020	90-03
4700008030	90-04 (Double)

## Security locks block arc

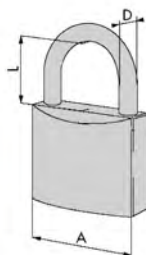

- Security padlock brass cylinder block.
- Arco in hardened steel and chrome.
- Standard equipment: two keys.

Code	Desc.	D mm	A mm	L mm
4700003640	2552/5	5	30	17
4700003645	2552/6	6	40	23
4700003650	2552/8	8	50	27,5

## Padlock security steel

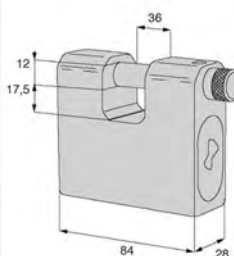

- Armored padlock security rectangular with ball locking.
- Piece body in hardened steel with anticorrosive treatment of chemical nickel.
- Hardened steel shackle with anti-cut chemical nickel treatment.
- Protective plates per cylinder and cylinder, both in hardened steel midsole.
- Standard equipment: two keys.

Code	Desc.
4700003665	2554C

## Cart under machine



- Tubular and painted sheet cushion.
- 4 Wheel  $\varnothing$  40.
- Dimensions: alt. 100 mm - lung. 950 mm - larg. 435 mm.

Code	Desc.
3920000200	107

## Trolley tour



- Trolley anti-oil rubber. Supporting structure in tube  $\varnothing$  25x1,5 mm.
- 6 rotating wheels  $\varnothing$  50mm.
- Length 980 mm.
- Width 440 mm.
- Height 90 mm.
- Kg Weight with wheels. 9.

Code	Desc.	Characteristics
3920000400	110	CART
3920000500	111	SPARE WHEEL



## Tool trays applicable to Cart



- Polypropylene tub shockproof supplied as an accessory.
- Length 300 mm.
- Width 185 mm.
- 40 mm deep.
- Weight 215 grams.
- On the trolley can be mounted up No. 2 pans.

Code	Desc.	Characteristics
3920000600	112	BOWL

## Carpets protection



- New carpets in plastzote
- Green Colour
- New material resistant to oils and fats
- Practical Rugs suitable for those who prefer models with wheels
- Extremely lightweight and strong
- Practical to transport
- Large carpet only 500 gr
- Small carpet only 200 gr

Code	Description	Measures (mm)
3920000700	113-large protection mat	995x495
3920000800	114-small protective mat	550x245



## Established 1 meter workshop



- Machining plane bench with galvanized sheet metal.
- Thickness: 3mm plan galvanized sheet metal, 1.5 mm structure.
- With bottom shelf and amounts tole painted in green colors ral6029 brilliant.
- Supplied disassembled.
- Weight: 42 kg.
- Range: 1000 kg.

Code	Desc.
4700007700	805-1MT

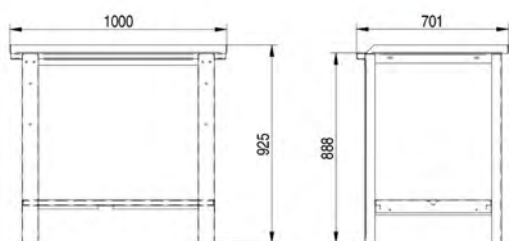

## Established Workshop 2 meters



- Machining plane bench with galvanized sheet metal.
- Thickness: 3mm plan galvanized sheet metal, 1.5 mm structure.
- With bottom shelf and amounts tole painted in green colors ral6029 brilliant.
- Weight 76 kg.
- Range: 2000 kg

Code	Desc.
4700007710	806-2MT

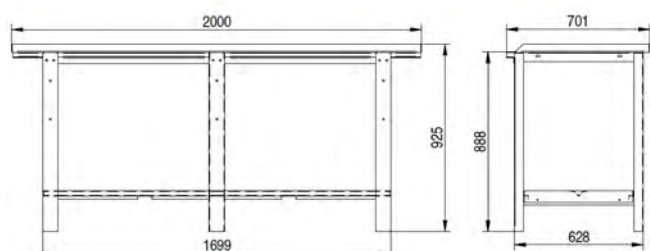

## 1 drawer for our machining benches and 2 meters



- Drawer guides.
- In tole painted in bright green colors ral6029.
- Weight: kg12.
- Drawer dimensions: 470x470 mm inside hauteur147 mm.

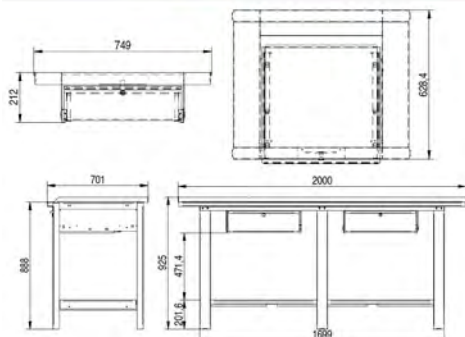

Code	Description
4700007720	807-DRAWER

## Perforated panels complete with mounting brackets to our workbenches

- Dimensions: length 980mm x 460mm height.
- Green RAL 6029 gloss.

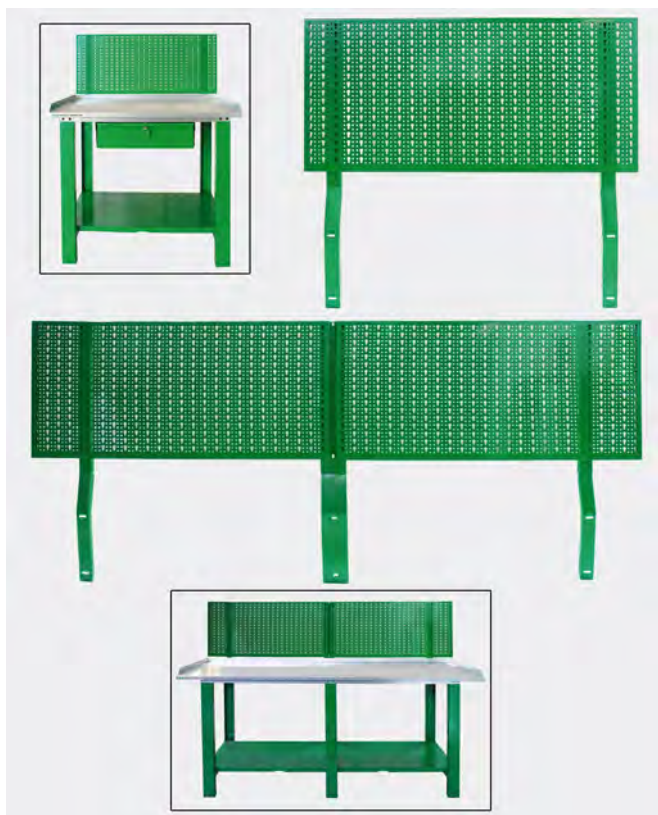

Code	Description	Measure	Attaching
4700007730	808 X 1MT BENCH	980X460	with 2 brackets
4700007740	809 X 2 MT BENCH	2X980X460	with 3 brackets

## Wardrobe toolholders



- Painted sheet metal cabinet in the color green ral 6029 shiny.
- With 2 doors and gray ral 7011 internal drawer.
- Perforated panels also introduced on 2 wickets.
- Load capacity: 27 kg.
- Dimensions: length 655mm x 800mm high x 310mm deep.

Code	Desc.
4700007665	804

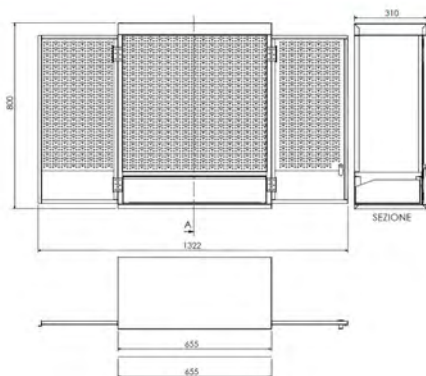

## Steel vise



- Parallel vise entirely forged steel C43.
- Double adjustable prismatic guide.
- Serrated jaws induction hardened and ground.
- Hardness: HRC 45/48.

Code	Desc.	Clamp width mm	Jaw opening mm	Jaws slide height mm	Weight Kg.
4430034450	391 - 100	100	130	60	7
4430034470	391 - 125	125	150	70	12
4430034500	391 - 150	150	180	80	19



## Covers magnetic jaws

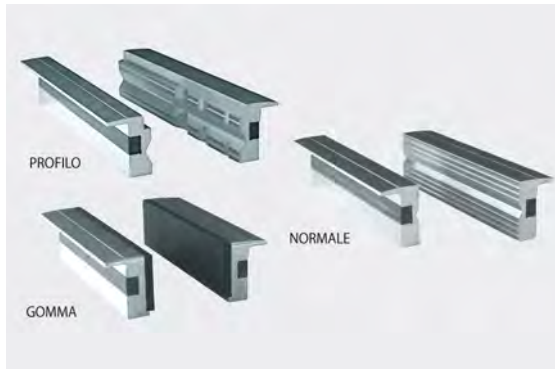

- Magnetic Cover jaw pair for all types of vices.
- With aluminum support.

Code	Desc.	For clamps with jaws	Finishing
4430034510	391G - 100	80 A 105	GUM
4430034515	391G - 125	110 A 125	GUM
4430034520	391G - 150	130 A 150	GUM
4430034530	391N - 100	80 A 105	NORMAL
4430034535	391N - 125	110 A 125	NORMAL
4430034540	391N - 150	130 A 150	NORMAL
4430034550	391P - 100	80 A 105	PROFILES
4430034555	391P - 125	110 A 125	PROFILES
4430034560	391P - 150	130 A 150	PROFILES

## EQUIPMENT COMMERCIAL VEHICLES MECCANOCAR

- Meccanocar proposes nine modular standard solutions for the preparation of the vans and commercial vehicles.
- Intended Use: electrical, plumbing, installers generally, bodywork and maintenance in general, repairers, roadside assistance, tire dealers, repair shops forklifts.
- The settings allow you to create mobile workshops within each half and to have at hand all the necessary equipment for their work in an orderly and efficient.
- Wide choice of equipment designed to meet the diverse needs of professionals and cover almost all 'of commercial vehicles in circulation.
- Possibility 'to handle even the individual modules that make up the engine blocks to create the right solution for the customer.
- The engine blocks and the individual modules of the kit components are supplied respectively of brackets and small parts for assembly.

### Fixing brackets kit for monoblock



- Kit of brackets indicated for the fixing of the monoblock to the van.
- Consisting of four brackets and sixteen steel rivets 4.8 x 16.

Code	Description
4700007345	605 - mounting brackets kit monoblock

### Monoblock model 1



- Monoblock model 1.
- High-strength steel structure.
- A wheel arch with retractable aluminum roll.
- Worktop plywood treated anti-oil.
- A chest of drawers composed of three briefcases extractable of which a by H.66 mm equipped with 23 plastic trays managed as spare parts.
- A chest of drawers with three drawers with fixed handles ergonomic, anti-oil and anti-vibration pad.
- Supplied with fixing kit to anchor the structure to the medium, our code 470 00 07345.

Code	Desc.	LxHxP mm	Weight Kg.
4700007300	560	1014 X 986 X 360	72

#### COMPOSIZIONE

CODICE	DESCRIZIONE	PEZZI
470 00 07385	COPRIPASSARUOTA CON SERRANDA 1.014X483X360 MM	1
470 00 07350	CASSETTIERA DA 507X483X360 MM CON 1 CASSETTO H.200 MM E 2 CASSETTI H.100 MM	1
470 00 07375	CASSETTIERA 507X483X360 MM CON 3 VASSOI, 1 VALIGIA H.66 MM CON 23 VASCHE, 1 VALIGIA H.100 MM VUOTA E 1 VALIGIA H.130 MM VUOTA	1
470 00 07440	PIANA IN LEGNO PER PIANO DI LAVORO 1.014X20X360 MM	1

## Monoblock model 2



- Monoblock model 2.
- Particularly suitable for the electricity sector, and plumbing and heating where you need to make space for the transport of bulky material.
- High-strength steel structure.
- A wheel arch with retractable aluminum roll.
- Shelving with 12 dividers, oil resistant and anti-vibration pad.
- Supplied with fixing kit to anchor the structure to the medium, our code 470 00 07345.

Code	Desc.	LxHxP mm	Weight Kg.
4700007305	565	1014 X 1065 X 360	30

### COMPOSIZIONE

CODICE	DESCRIZIONE	PEZZI
470 00 07385	COPRIPASSARUOTA CON SERRANDA 1.014X483X360 MM	1
470 00 07410	SCAFFALATURA 1.014X241X360 MM CON 4 DIVISORI	2
470 00 07425	SCAFFALATURA TERMINALE 1.014X100X260 MM CON 4 DIVISORI	1

## Monoblock model 3



- Monoblock model 3.
- High-strength steel structure.
- A wheel arch with retractable aluminum roll.
- Worktop plywood treated anti-oil.
- A chest of drawers made of four cases extractable by H 66 mm including two equipped with 23 plastic.
- Two drawers composed of four fixed drawers each, equipped with ergonomic handles, anti-oil and anti-vibration pad.
- Supplied with fixing kit to anchor the structure to the medium, our code 470 00 07345.

Code	Desc.	LxHxP mm	Weight Kg.
4700007310	570	1521 x 986 x 360	135

### COMPOSIZIONE

CODICE	DESCRIZIONE	PEZZI
470 00 07395	COPRIPASSARUOTA CON SERRANDA 1.521X483X360 MM	1
470 00 07360	CASSETTIERA DA 507X483X360 MM CON 4 CASSETTI H.100 MM	1
470 00 07355	CASSETTIERA DA 507X483X360 MM CON 1 CASSETTO H.66 MM , 2 CASSETTI H.100 MM E 1 CASSETTO H.130 MM	1
470 00 07380	CASSETTIERA 507X483X360 MM CON 4 VASSOI E 4 VALIGIE H.66 MM DI CUI DUE CON ALL'INTERNO 23 VASCHE	1
470 00 07450	PIANA IN LEGNO PER PIANO DI LAVORO 1.521X20X360 MM	1



## Monoblock model 4



- Monoblock model 4.
- Particularly suitable for the electricity sector, and plumbing and heating where you need to make space for the transport of bulky material.
- High-strength steel structure.
- A wheel arch with retractable aluminum roll.
- A dresser with two drawers with fixed handles ergonomic, anti-oil and anti-vibration pad; two cases, one from removable H.66 mm equipped with 23 plastic.
- Shelving with 14 dividers, oil resistant and anti-vibration pad.
- Supplied with fixing kit to anchor the structure to the medium, our code 470 00 07345.

Code	Desc.	LxHxP mm	Weight Kg.
4700007315	575	1521 x 1075 x 360	84

### COMPOSIZIONE

CODICE	DESCRIZIONE	PEZZI
470 00 07395	COPRIPASSARUOTA CON SERRANDA 1.521X483X360 MM	1
470 00 07365	CASSETTIERA 507X483X360 MM CON 2 VASSOI, 1 VALIGIA H.66 MM CON 23 VASCHETTE, 1 VALIGIA H.130 MM E 2 CASSETTI H. 66 MM.	1
470 00 07410	SCAFFALATURA 1.014X241X360 MM CON 4 DIVISORI	2
470 00 07435	SCAFFALATURA TERMINALE 1.521X110X360 MM CON 6 DIVISORI	1

## Monoblock model 5



- 5-piece model.
- Particularly suitable for the electricity sector, and plumbing and heating where you need to make space for the transport of bulky material.
- High-strength steel structure.
- A wheel arch with retractable aluminum roll.
- Shelving with 15 dividers, oil resistant and anti-vibration pad.
- Supplied with fixing kit to anchor the structure to the medium, our code 470 00 07345.

Code	Desc.	LxHxP mm	Weight Kg.
4700007320	580	1268 x 1075 x 360	38

### COMPOSIZIONE

CODICE	DESCRIZIONE	PEZZI
470 00 07390	COPRIPASSARUOTA CON SERRANDA 1.268X483X360 MM	1
470 00 07415	SCAFFALATURA 1.268X241X360 MM CON 5 DIVISORI	2
470 00 07430	SCAFFALATURA TERMINALE 1.268X110X360 MM CON 5 DIVISORI	1



## Monoblock model 6



- Monoblock model 6.
- Particularly suitable for the electricity sector, and plumbing and heating where you need to make space for the transport of bulky material.
- High-strength steel structure.
- A wheel arch with retractable aluminum roll.
- A dresser with two drawers with fixed handles ergonomic, anti-oil and anti-vibration pad; two cases, one from removable H.66 mm equipped with 23 plastic.
- Shelving with 11 dividers, oil resistant and anti-vibration pad.
- Supplied with fixing kit to anchor the structure to the medium, our code 470 00 07345.

Code	Desc.	LxHxP mm	Weight Kg.
4700007325	585	1268 x 1075 x 360	75

### COMPOSIZIONE

CODICE	DESCRIZIONE	PEZZI
470 00 07390	COPRIPASSARUOTA CON SERRANDA 1.268X483X360 MM	1
470 00 07365	CASSETTIERA 507X483X360 MM CON 2 VASSOI, 1 VALIGIA H.66 MM CON 23 VASCHETTE, 1 VALIGIA H.130 MM E 2 CASSETTI H.66 MM	1
470 00 07405	SCAFFALATURA 760X241X360 MM CON 3 DIVISORI	2
470 00 07430	SCAFFALATURA TERMINALE 1.268X110X360 MM CON 5 DIVISORI	1

## Monoblock model 7



- Monoblock model 7.
- Particularly suitable for the electricity sector, and plumbing and heating where you need to make space for the transport of bulky material.
- High-strength steel structure.
- A wheel arch with retractable aluminum roll.
- Shelving with 18 dividers, oil resistant and anti-vibration pad.
- Supplied with fixing kit to anchor the structure to the medium, our code 470 00 07345.

Code	Desc.	LxHxP mm	Weight Kg.
4700007330	590	1521 x 1075 x 360	41

### COMPOSIZIONE

CODICE	DESCRIZIONE	PEZZI
470 00 07395	COPRIPASSARUOTA CON SERRANDA 1.521X483X360 MM	1
470 00 07420	SCAFFALATURA 1.521X241X360 MM CON 6 DIVISORI	2
470 00 07435	SCAFFALATURA TERMINALE 1.521X110X360 MM CON 6 DIVISORI	1

## Monoblock model 8



- Monoblock model 8.
- Particularly suitable for the electricity sector, and plumbing and heating where you need to make space for the transport of bulky material.
- High-strength steel structure.
- A wheel arch with door swinging.
- Shelving with 12 dividers, oil resistant and anti-vibration pad.
- Supplied with fixing kit to anchor the structure to the medium, our code 470 00 07345.

Code	Desc.	LxHxP mm	Weight Kg.
4700007335	595	1014 x 984 x 360	34

### COMPOSIZIONE

CODICE	DESCRIZIONE	PEZZI
470 00 07400	COPRIPASSARUOTA CON ANTINA DI CHIUSURA SCANTONATO 1014X402X360 MM	1
470 00 07410	SCAFFALATURA 1.014X241X360 MM CON 4 DIVISORI	2
470 00 07425	SCAFFALATURA TERMINALE 1.014X100X260 MM CON 4 DIVISORI	1

## Monoblock model 9



- Monoblock model 9.
- High-strength steel structure.
- A wheel arch with door swinging.
- A dresser with four drawers with fixed handles ergonomic, anti-oil and anti-vibration pad.
- A dresser with two drawers with fixed handles ergonomic, anti-oil and anti-vibration pad; two cases, one from removable H.66 mm equipped with 23 plastic.
- Shelving with four dividers, oil resistant and anti-vibration pad.
- Supplied with fixing kit to anchor the structure to the medium, our code 470 00 07345.

Code	Desc.	LxHxP mm	Weight Kg.
4700007340	600	1014 x 984 x 360	92

### COMPOSIZIONE

CODICE	DESCRIZIONE	PEZZI
470 00 07400	COPRIPASSARUOTA CON ANTINA DI CHIUSURA SCANTONATO 1014X402X360 MM	1
470 00 07355	CASSETTIERA DA 507X483X360 MM CON 1 CASSETTO H.66 MM, 2 CASSETTI H.100 MM E 1 CASSETTO H. 130 MM	1
470 00 07370	CASSETTIERA 507X483X360 MM CON 2 VASSOI, 2 VALIGIE H.66 MM DI CUI UNA DOTATA DI 23 VASCHE E 2 CASSETTI H.100 MM	1
470 00 07425	SCAFFALATURA TERMINALE 1.014X100X260 MM CON 4 DIVISORI	1

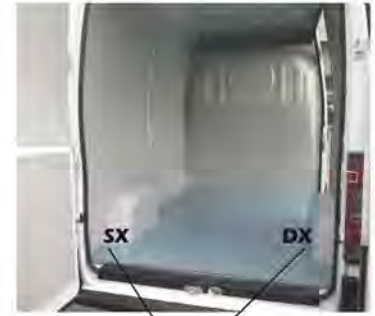
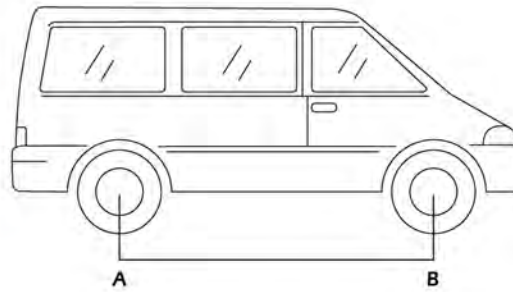

**TABELLA APPLICAZIONI MONOBLOCCHI**

**esempio allestimento**

**passaruota**

		1014x483		1014x483		1521x483		1521x483		1268x483		1268x483		1521x483		1014x402		1014x402	
		MON.1 470 00 07300		MON.2 470 00 07305		MON.3 470 00 07310		MON.4 470 00 07315		MON.5 470 00 07320		MON.6 470 00 07325		MON.7 470 00 07330		MON.8 470 00 07335		MON.9 470 00 07340	
MODELLO	A - B (MM)	SX	DX	SX	DX	SX	DX	SX	DX	SX	DX	SX	DX	SX	DX	SX	DX	SX	DX
<b>BERLINGO</b> <b>NUOVO BERLINGO</b>	2693			X												X			X
	2728			X						X		X				X			X
<b>JUMPY L1</b> <b>JUMPY L2</b>	3000	X	X	X	X	X		X		X		X		X					
	3122	X	X	X	X	X		X		X	X	X		X					
<b>JUMPER L1</b> <b>JUMPER L2</b> <b>JUMPER L3</b> <b>JUMPER L4</b>	3000	X	X	X	X	X		X		X		X	X	X					
	3450	X	X	X	X	X	X	X	X	X		X	X	X	X				
	4035	X	X	X	X	X	X	X	X	X		X	X	X	X				
	4035	X	X	X	X	X	X	X	X	X		X	X	X	X				

		MON.1 470 00 07300		MON.2 470 00 07305		MON.3 470 00 07310		MON.4 470 00 07315		MON.5 470 00 07320		MON.6 470 00 07325		MON.7 470 00 07330		MON.8 470 00 07335		MON.9 470 00 07340	
MODELLO	A - B (MM)	SX	DX	SX	DX	SX	DX	SX	DX	SX	DX	SX	DX	SX	DX	SX	DX	SX	DX
<b>DOBLO</b> <b>DOBLO</b>	2583	X		X						X		X		X					
	2963	X	X	X	X	X		X		X	X	X	X	X					
<b>SCUDO</b> <b>SCUDO</b>	3000	X	X	X	X	X		X		X		X		X					
	3122	X	X	X	X	X		X		X	X	X	X	X					
<b>DUCATO</b> <b>DUCATO</b> <b>DUCATO</b> <b>DUCATO</b>	3000	X	X	X	X	X		X		X		X	X	X					
	3450	X	X	X	X	X	X	X	X	X	X	X	X	X	X				
	4035	X	X	X	X	X	X	X	X	X	X	X	X	X	X				
	4035 XL	X	X	X	X	X	X	X	X	X	X	X	X	X	X				

		MON.1 470 00 07300		MON.2 470 00 07305		MON.3 470 00 07310		MON.4 470 00 07315		MON.5 470 00 07320		MON.6 470 00 07325		MON.7 470 00 07330		MON.8 470 00 07335		MON.9 470 00 07340	
MODELLO	A - B (MM)	SX	DX	SX	DX	SX	DX	SX	DX	SX	DX	SX	DX	SX	DX	SX	DX	SX	DX
<b>CONNECT</b> <b>CONNECT</b>	2664	X		X						X		X		X		X		X	
	2912	X		X		X		X		X		X		X		X		X	
<b>TRANSIT</b> <b>TRANSIT</b> <b>TRANSIT</b> <b>TRANSIT JUMBO</b>	2933	X	X	X	X	X		X		X		X	X	X					
	3300	X	X	X	X	X	X	X	X	X		X	X	X	X				
	3750	X	X	X	X	X	X	X	X	X	X	X	X	X	X				
	3750	X	X	X	X	X	X	X	X	X	X	X	X	X	X				

		MON.1 470 00 07300		MON.2 470 00 07305		MON.3 470 00 07310		MON.4 470 00 07315		MON.5 470 00 07320		MON.6 470 00 07325		MON.7 470 00 07330		MON.8 470 00 07335		MON.9 470 00 07340	
MODELLO	A - B (MM)	SX	DX	SX	DX	SX	DX	SX	DX	SX	DX	SX	DX	SX	DX	SX	DX	SX	DX
<b>VITO COMPACT</b> <b>VITO COMPACT LONG</b> <b>VITO EXTRA LONG</b>	3200	X	X	X	X	X		X		X		X		X		X	X	X	X
	3430	X	X	X	X	X	X	X	X	X	X	X	X	X	X	X	X	X	X
	3430	X	X	X	X	X	X	X	X	X	X	X	X	X	X	X	X	X	X
<b>SPRINTER</b> <b>SPRINTER</b> <b>SPRINTER</b> <b>SPRINTER EXTRA LONG</b>	3000	X	X	X	X	X		X		X	X	X	X	X		X	X	X	X
	3550	X	X	X	X	X	X	X	X	X	X	X	X	X	X	X	X	X	X
	4025	X	X	X	X	X	X	X	X	X	X	X	X	X	X	X	X	X	X
	4025	X	X	X	X	X	X	X	X	X	X	X	X	X	X	X	X	X	X



		1014x483		1014x483		1521x483		1521x483		1268x483		1268x483		1521x483		1014x402		1014x402	
		MON.1 470 00 07300		MON.2 470 00 07305		MON.3 470 00 07310		MON.4 470 00 07315		MON.5 470 00 07320		MON.6 470 00 07325		MON.7 470 00 07330		MON.8 470 00 07335		MON.9 470 00 07340	
MODELLO	A - B (MM)	SX	DX	SX	DX	SX	DX	SX	DX	SX	DX	SX	DX	SX	DX	SX	DX	SX	DX
<b>KUBISTAR</b> KUBISTAR MAXI	2605	X		X								X				X		X	
	2605	X	X	X				X				X				X	X	X	X
<b>PRIMASTAR</b> PRIMASTAR	3098	X	X	X	X	X		X		X		X		X		X	X	X	X
	3498	X	X	X	X	X		X		X	X	X		X		X	X	X	X
<b>INTERSTAR</b> INTERSTAR INTERSTAR	3078	X	X	X	X	X		X		X	X	X		X					
	3578	X	X	X	X	X	X	X	X	X	X	X	X	X	X				
	4078	X	X	X	X	X	X	X	X	X	X	X	X	X	X				

		MON.1 470 00 07300		MON.2 470 00 07305		MON.3 470 00 07310		MON.4 470 00 07315		MON.5 470 00 07320		MON.6 470 00 07325		MON.7 470 00 07330		MON.8 470 00 07335		MON.9 470 00 07340	
MODELLO	A - B (MM)	SX	DX	SX	DX	SX	DX	SX	DX	SX	DX	SX	DX	SX	DX	SX	DX	SX	DX
<b>COMBO</b>	2716	X		X												X		X	
<b>VIVARO</b> VIVARO	3098	X	X	X	X	X		X		X		X		X		X	X	X	X
	3498	X	X	X	X	X		X		X	X	X		X		X	X	X	X
<b>MOVANO</b> MOVANO MOVANO	3078	X	X	X	X	X		X		X	X	X		X					
	3578	X	X	X	X	X	X	X	X	X	X	X	X	X	X				
	4078	X	X	X	X	X	X	X	X	X	X	X	X	X	X				

		MON.1 470 00 07300		MON.2 470 00 07305		MON.3 470 00 07310		MON.4 470 00 07315		MON.5 470 00 07320		MON.6 470 00 07325		MON.7 470 00 07330		MON.8 470 00 07335		MON.9 470 00 07340	
MODELLO	A - B (MM)	SX	DX	SX	DX	SX	DX	SX	DX	SX	DX	SX	DX	SX	DX	SX	DX	SX	DX
<b>RANCH</b>	2693	X		X												X		X	
<b>PARTNER</b>	2728	X		X						X		X				X		X	
<b>EXPERT L1</b> EXPERT L2	3000	X	X	X	X	X		X		X		X		X					
	3122	X	X	X	X	X		X		X	X	X		X					
<b>BOXER L1</b> BOXER L2 BOXER L3 BOXER L4	3000	X	X	X	X	X		X		X		X		X					
	3450	X	X	X	X	X	X	X	X	X	X	X	X	X	X				
	4035	X	X	X	X	X	X	X	X	X	X	X	X	X	X				
	4035	X	X	X	X	X	X	X	X	X	X	X	X	X	X				

		MON.1 470 00 07300		MON.2 470 00 07305		MON.3 470 00 07310		MON.4 470 00 07315		MON.5 470 00 07320		MON.6 470 00 07325		MON.7 470 00 07330		MON.8 470 00 07335		MON.9 470 00 07340	
MODELLO	A - B (MM)	SX	DX	SX	DX	SX	DX	SX	DX	SX	DX	SX	DX	SX	DX	SX	DX	SX	DX
<b>KANGOO</b> KANGOO MAXI NUOVO KANGOO	2605	X		X								X				X		X	
	2605	X	X	X				X				X		X		X	X	X	X
	2697	X		X								X				X		X	
<b>NEW TRAFFIC L1</b> NEW TRAFFIC L2	3098	X	X	X	X	X		X		X		X		X		X	X	X	X
	3498	X	X	X	X	X		X		X	X	X		X		X	X	X	X
<b>MASTER L1</b> MASTER L2 MASTER L3 MASTER L4	3078	X	X	X	X	X		X		X	X	X		X					
	3578	X	X	X	X	X	X	X	X	X	X	X	X	X	X				
	4078	X	X	X	X	X	X	X	X	X	X	X	X	X	X				
	4078	X	X	X	X	X	X	X	X	X	X	X	X	X	X				

		MON.1 470 00 07300		MON.2 470 00 07305		MON.3 470 00 07310		MON.4 470 00 07315		MON.5 470 00 07320		MON.6 470 00 07325		MON.7 470 00 07330		MON.8 470 00 07335		MON.9 470 00 07340	
MODELLO	A - B (MM)	SX	DX	SX	DX	SX	DX	SX	DX	SX	DX	SX	DX	SX	DX	SX	DX	SX	DX
<b>CADDY</b> CADDY MAXI	2682	X		X						X		X				X		X	
	3002	X		X						X		X				X		X	
<b>TRANSPORTER</b> TRANSPORTER	3000	X	X	X	X	X		X		X		X		X		X	X	X	X
	3400	X	X	X	X	X	X	X		X	X	X		X	X	X	X	X	X
<b>CRAFTER</b> CRAFTER CRAFTER CRAFTER EXTRA LONG	3250	X	X	X	X	X		X		X	X	X		X		X	X	X	X
	3665	X	X	X	X	X	X	X	X	X	X	X	X	X	X	X	X	X	X
	4325	X	X	X	X	X	X	X	X	X	X	X	X	X	X	X	X	X	X
	4325	X	X	X	X	X	X	X	X	X	X	X	X	X	X	X	X	X	X



## COMPONENTS MODULES

Meccanocar offers the possibility to create a customized design for customers through management of individual modules. To offer a good service to the customer, measure the maximum dimensions of the passage of the wheel (WxHxD) and select the guard indicated for the van.

Having established the correct module, it is possible to achieve the desired development on the basis of the dimensions of the protective casing for the passage of the wheel.

Regarding the total height of the development, it is advisable to carefully measure the vehicle possibly helping with the measurements given in the diagrams of the piece.

### Cover wheel with damper



- The wheel cover can mount and align all the modules above it at the same time obtaining practical loading zones.
- Aluminum roll retractable.
- A wheel arch full of small parts for the application on other modules.

Code	Desc.	LxHxD mm	Weight Kg.
4700007385	645	1014 x 483 x 360	11,63
4700007390	650	1268 x 483 x 360	12,69
4700007395	655	1521 x 483 x 360	14,12

### Cover wheel housing with door closing notched



- The wheel arch allows you to mount and align all the modules above it at the same time obtaining practical loading zones.
- Antina closing tilting high-strength steel.
- A wheel arch full of small parts for the application on other modules.

Code	Desc.	LxHxD mm	Weight Kg.
4700007400	660	1014 x 402 x 360	9,08

## Module 1 drawer H 200 mm and 2 drawers H 100 mm



- Composition: a drawer H.200 mm, two drawers H.100 mm.
- Drawers with double automatic locking system, ergonomic handles, oil resistant mat and antibrazione.
- Drawer full of small parts for the application on other modules.

Code	Description	LxHxP mm	Weight Kg.
4700007350	610 - Module 1 drawer H 200 mm, 2 drawers 100 mm h	507 x 483 x 360	17,75

## Module 1 drawer H 66 mm, 2 drawers H 100 mm, 1 drawer 130 mm H



- Composition: a drawer H.66 mm, two drawers H.100 mm, a drawer H 130 mm.
- Drawers with double automatic locking system, ergonomic handles, oil resistant mat and antibrazione.
- Drawer full of small parts for the application on other modules.

Code	Description	LxHxP mm	Weight Kg.
4700007355	615 - Module 1 drawer H 66 mm, 2 drawers H 100 mm, 1 drawer 130 mm H	507 x 483 x 360	19,81

## Module with 4 drawers H 100 mm



- Composition: four drawers H.100 mm.
- Drawers with double automatic locking system, ergonomic handles, anti-oil and anti-vibration pad.
- Drawer full of small parts for the application on other modules.

Code	Description	LxHxP mm	Weight Kg.
4700007360	620 - Module with 4 drawers H 100 mm	507 x 483 x 360	19,44

## Module 2 drawers H 66 mm, 66 mm H 2 briefcases and H 130 mm



- Composition: two drawers H.66 mm, a briefcase removable empty H.130 mm, a briefcase removable H.66 mm comes with 23 plastic.
- Drawers with double automatic locking system, ergonomic handles, anti-oil and anti-vibration pad.
- Cases made of steel and powder coated polyester for long life, with ergonomic handle and safety lock. Inside the lid is inserted a sponge to seal up the containers during transportation.
- Drawer full of small parts for the application on other modules.

Code	Description	LxHxP mm	Weight Kg.
4700007365	625 - Module with 2 drawers H 66 mm, 130 mm H 1 case, 1 case H 66 mm	507 x 483 x 360	23,97

## Module 2 briefcases H 66 mm and 2 drawers H 100 mm



- Composition: 2 removable 66mm cases h, one containing 23 plastic bins, 2 drawers h 100 mm.
- Drawers with automatic double locking system, ergonomic handles, mat protection against oil and vibration.
- Cases made from steel and painted polyester powders for long term provided ergonomic handle and a safety closure. The inside cover contains a sponge to block and protect the containers during transportation.
- Drawer module provided with all the fixing screws for application to the other modules.

Code	Description	LxHxP mm	Weight Kg.
4700007370	630 - Module 2 briefcases H 66 mm, 2 drawers H 100 mm	507 x 483 x 360	25,09

## Module 3 Cases H 66 mm, H 100 mm and 130 mm H



- Composition: a briefcase removable H.66 mm comes with 23 plastic trays, a removable briefcase empty H.100 mm and a briefcase removable empty H.130 mm.
- Cases made of steel and powder coated polyester for long life. with an ergonomic handle and safety lock. Inside the lid is inserted a sponge to seal up the containers during transportation.
- Drawer full of small parts for the application on other modules.

Code	Description	LxHxP mm	Weight Kg.
4700007375	635 - Module 3 Cases H 66 mm, H 100 mm and 130 mm H	507 x 483 x 360	26,63

## Module 4 Cases H 66 mm



- Composition: four briefcases removable H.66 mm, two of which came with 23 plastic.
- Cases made of steel and powder coated polyester for long life. with an ergonomic handle and safety lock. Inside the lid is inserted a sponge to seal up the containers during transportation.
- Drawer full of small parts for the application on other modules.

Code	Description	LxHxP mm	Weight Kg.
4700007380	640 - Module 4 Cases H 66 mm	507 x 483 x 360	30,72

## Intermediate Shelves

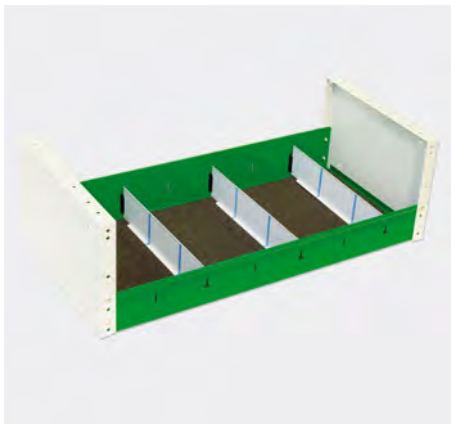

- Shelves fitted with adjustable partitions, a non-slip mat and anti-vibration
- Supplied in block two pieces already assembled.
- Provided with all the screws for application to the other modules.

Code	Desc.	LxHxP mm	Weight Kg.	Dividers
4700007405	665	760 X 241 X 360	6,91	3
4700007410	670	1014 X 241 X 360	9,57	4
4700007415	675	1268 X 241 X 360	11,13	5
4700007420	680	1521 X 241 X 360	13,03	6

## Final Shelves

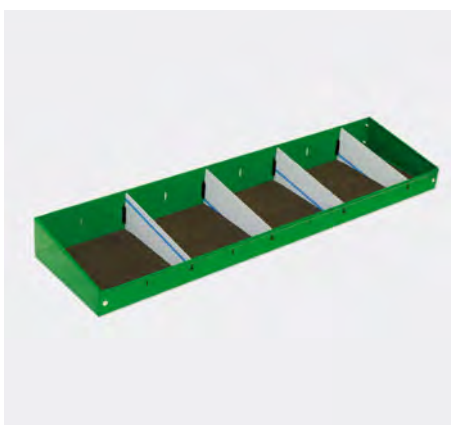

- Shelves fitted with adjustable partitions, a non-slip mat and anti-vibration.
- Provided with all the screws for application to the other modules.

Code	Desc.	LxHxP mm	Weight Kg.	Dividers
4700007425	685	1014 X 100 X 260	4,59	4
4700007430	690	1268 X 110 X 360	9,41	5
4700007435	695	1521 X 110 X 360	11,31	6



## Wooden worktops



- End wooden worktops.
- Wood laminate factories 20mm treats against oil.
- Provided with all the fixing screws for the assembly on the other components.

Code	Desc.	LxHxP mm	Weight Kg.
4700007440	700	1014 X 20 X 360	3,43
4700007445	705	1268 X 20 X 360	4,29
4700007450	710	1521 X 20 X 360	5,13

## Toggle clamp holder



- Étau à latch holder provided with a device consists of a gas piston and a quick release system.
- Varnished steel manufactures powders for optimal resistance.
- Allows the operator to have, in the van, a bench vise on any door without having the support of the development.
- Compatible with our étaus a steel bench code 443 00 34450-443 00 34470-443 00 34 500.
- Length of the work plan (open): 891 mm.
- Holder clamp supplied with all the fixing screws.

Code	Description	L x H x P mm (closed)	Weight Kg.
4700007455	715 - toggle clamp holder	215 X 930 X 223	12,3

## Stands footing to toggle clamp holder



- Stands footing to toggle clamp holder (code 470 00 07 455).
- Varnished steel manufactures powders for optimal resistance.
- Increases the height of the holder clamp to allow the operator to work in an ergonomic position.
- Base with the fixing screws.

Code	Description	LxHxP mm	Weight Kg.
4700007460	720 - heightening base for rocking holder vise	215 X 161 X 223	3,7

## Universal roll holder for paper



- Aluminum structure painted in powders.

Code	Description	LxHxP mm	Weight Kg.
4700007465	725 - Holder for universal roll paper	297 X 200 X 154	0,7

## A container holder for plastic container



- Aluminum container holder for plastic container of 10 liters.
- Team of a belt to attach the container during transport.
- Compatible with our plastic container of 10 liters code 470 00 07471.

Code	Description	L x P mm (internal)	Weight Kg.
4700007470	730 - Porte container for plastic container of 10 liters	286 X 154	1,5

## Plastic canister for liquids



- Plastic container for liquids (capacity 10 liters).
- Equipped with a practical tap adjusts the water outflow.
- Compatible with our container carrier code 470 00 07470.
- Warning: not indicated to contain flammable liquids.

Code	Description
4700007471	731 - Plastic container 10 liters for 730

## Bar load retaining belt



- Load retaining bar steel.
- It allows to keep anchored to the van every type of load.
- Equipped with nylon strap, length 1500 mm, with tensioning ratchet.
- Bar length: 360 mm.
- Max capacity: 4000 kg.

Code	Description	Weight Kg.
4700007475	735 - Load locking bar L 360 MM	1,45

## Saddle cable carrier



- Saddle cable carrier made in aluminum, which is supporting cables with a maximum diameter of 90 mm.
- It can be attached to the modules or directly on the van.

Code	Description	Depth mm	Weight Kg.
4700007480	740 - Saddle cable carrier L 260 mm	90	0,52

## STANDS FOR MOTORCYCLE

- Painted tubular steel trestles.
- Extremely rugged and reliable.
- The stands are indicated, as well as for the interventions of maintenance or repair, even for long periods of stationary bikes, in fact avoid the ovality of the tires.

### Rear Model Universal



- With adjustable supports according to the opening of the rear swing arm motion.
- For motorcycles equipped with double swing arm with a rectangular section.
- For workshops and motorcycle dealerships.

Code	Desc.
4700003550	2543

Spare Parts	
Code	Description
4700003551	2543/A RUOTA DI RICAMBIO Ø 80mm
4700003552	SUPPORTI IN GOMMA



### Pair of supports to fork

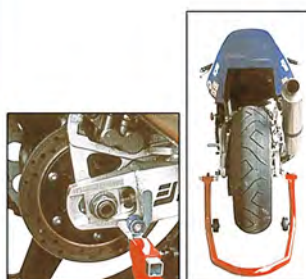

- Suitable for rear stand.
- For motorcycles equipped with double swing arm and fingers screw.
- For workshops and motorcycle dealerships.

Code	Desc.
4700003610	2549

### Couple aluminum adapters

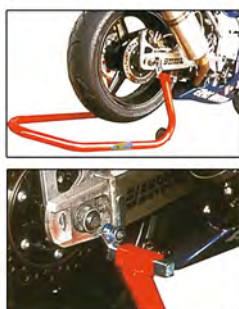

- Aluminum threaded adapters.
- With thread M6-M8-M10.
- Screw on the fork to attach the stand supports with fork.

Code	Desc.	Thread M
4700003620	2550 - M6	6
4700003625	2550 - M8	8
4700003630	2550 - M10	10



### Rear stand single arm Ducati.



- With pivot mounted on bearings to protect the hole housing the hub of the rear wheel.
- Particularly suitable for Ducati 916-748.

Code	Desc.
4700003560	2544

### Pin adapter for rear stand for use on Triumph Speed Triple T509, Daytona



- Stand cod. 470 00 03560.
- Diameter: 27mm.

Code	Desc.
4700003570	2545

### Front stand universal



- End part steel for long life and greater reliability.
- For workshops and motorcycle dealerships.

Code	Desc.
4700003580	2546

## Telescopic front stand under fork



- Suitable for all types of motorcycle provided with the hole in the steering head.
- With possibility of height adjustment.
- Equipped with 5 pins to fit various models  $\varnothing$  13-15-18-20-27.
- To be used only in combination with the rear stand.
- For workshops and motorcycle dealerships.

Code	Description
4700003600	2548

Spare Parts	
Code	Description
4700003601	Kit perni



PARTICOLARE  
PERNI

## Center easel for dirt bikes



Code	Desc.
4700003590	2547

## Centre stand for custom bikes

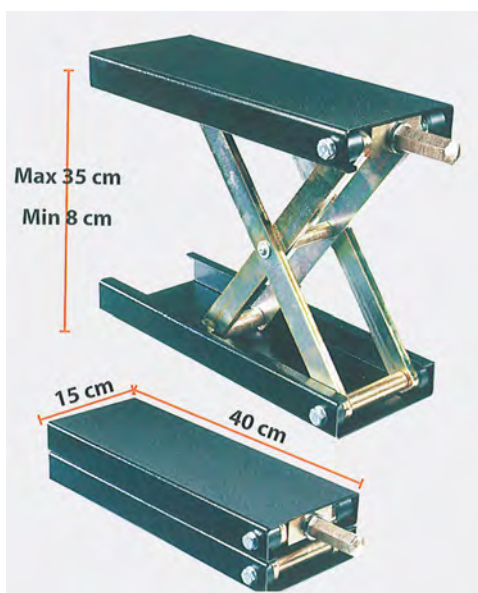

- Centre stand with mechanical lifting screw.
- Product Factory motorcycles and scooters.
- Do not use air guns to lift.

Code	Desc.
4700005700	2599

Technical Features	
Portata kg	400
Min/max height cm	8/35
Dimensions cm.	15x40

## Accessories Centre stand for custom bikes

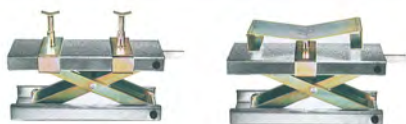
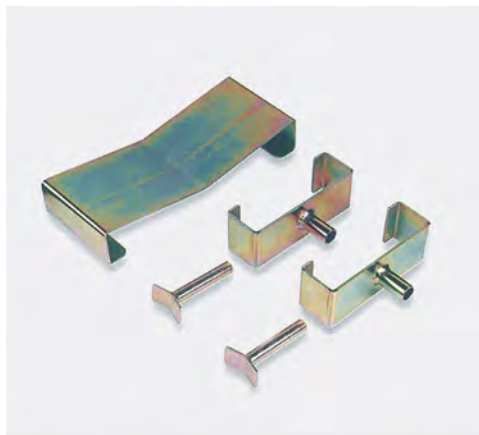

Code	Desc.
4700005705	2599K

## Universal support for motorcycles



- Universal support for motorcycles, scooters and maxi scooters.
- Complete rotation to 360°.
- With universal plate.
- Equipped with oil collection tank.
- With 4 swivel casters, two with brake.
- It allows you to work safely with the engine attached to the supports.
- Suitable for motorcycle workshop.

Code	Description	Photo
4700005915	2625-supporto universale per moto	1
4700005910	2620-adattatore moto Ducati	2
4700005912	2622-adattatore motori , scooter e maxiscooter	3

## Bridge for bike Meccanocar



- Lifting system for motorcycles.
- Product for workshops and dealers motorcycles and scooters.
- Tool particularly robust, stable and professional.
- The bridge motion Meccanocar with a height of 130 cm, superior to traditional lifters, and 11 positions of the mechanical safety, which makes it particularly suitable for working comfortably in all positions.
- The capacity of 500 kg makes it suitable to lift all two-wheeled vehicles on the market, the steel support structure allows considerable established 'during work.
- The system of vertical scissor lift gives established 'safety and reducing clutter than lifters who lift even obliquely.
- The plan of lifting large (210x99 cm) allows to work in a practical way, also, the curved side flaps allow a valid support for tools and small parts without risk of falling.
- Has a drawer concealed in order to work on the wheel without the lifting table bother the operator.
- Lift system quickly and safely through the pump hydropneumatic external foot or in the version with the electro-hydraulic pump with manual control provided.
- Supplied with ramp and tube stops motorcycles, grip chock supplied separately.
- In the electro-hydraulic version the supply voltage and of 220V.

Code	Description
4700005400	2596-Sollevatore moto con pompa idropneumatica
4700005500	2597-Sollevatore moto con pompa elettroidraulica 220V
4700005601	259N-Morsa meccanica apertura 70-215 mm

Technical Features	
Air consumption	300 Lt/min
Weight	250 kg
Ingombro totale	220x92 cm
Rising ramp dimensions	62x44,5cm
Ingombro totale piano di sollevamento	210x92cm
Drawer dimensions	50x36cm
Side wings dimensions	200x8,5cm
Lifting table dimensions	210x75cm
Min. height from the ground	19 cm
Portata	500 kg
max height. from the ground	130 cm



## Hydraulic bottle jack



- Hydraulic bottle jack for industrial use. suitable for cars and V.I. workshops, drivers, service stations, etc.
- Hydraulic system with by-pass valve against the overextension of the piston, for a total safety of the operator.
- The very compact dimensions allow easy transport and opportunity to store it in small spaces.
- Possibility to provide the model 20 tons in low version.
- **\*\* Model without the adjustment screw**

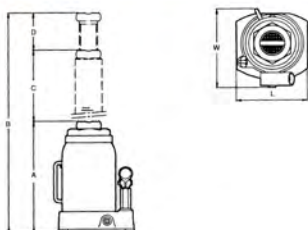

Code	Desc.	Payload (TON)	A mm	B mm	C mm	D	LxW mm	Weight Kg.
4700007020	320/2	2	158	308	90	60 mm	92x90	2,2
4700007025	320/4	4	180	350	110	60 mm	110x101	3,5
4700007030	320/6	6	197	382	125	60 mm	115x112	4,3
4700007035	320/8	8	205	390	125	60 mm	121x120	6,3
4700007040	320/12	12	214	399	125	60 mm	131x130	8
4700007045	320/16	16	225	425	140	60 mm	141x138	9,45
4700007050	320/20	20	244	449	145	60 mm	159x150	10,75
4700007055	320/20S*	20	190	340	90	60 mm	159x150	8,7
4700007060	320/30**	30	285	465	180	-	207x174	15,8

## Lifter trolley aluminum 1,35 ton

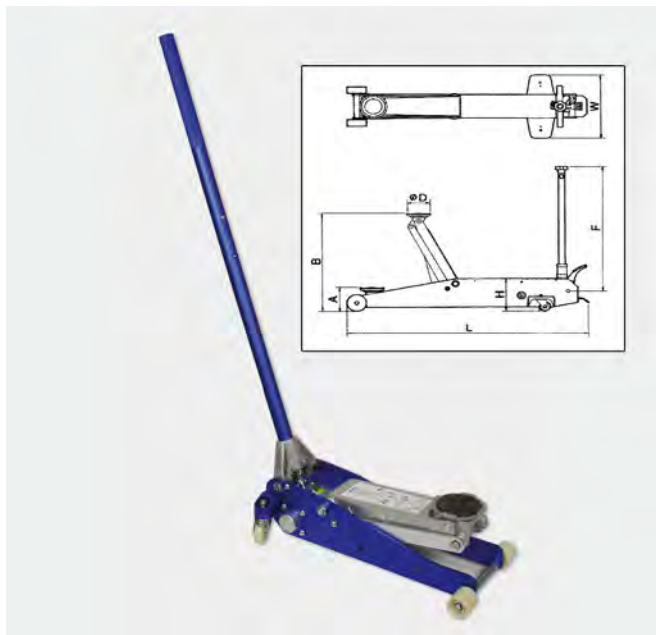

- Lifter trolley compact and lightweight, with a structure entirely made of aluminum alloy and professional hydraulic pump capacity of 1.35 tons lifting.
- Useful in machine shops, body shops, roadside assistance, automotive team.
- Maximum flexibility of use thanks to the compactness and light weight of only 10 kilograms which makes it easily transportable and storable in any space.
- The minimum height of 8 cm from the ground allows to enter under the cars also very lowered, the handle is easily removable and divisible in two pieces, which limits the overall dimensions further.
- With nylon wheels very resistant and very sliding.
- With safety valve that protects the hydraulic unit from overloads and increases its safety of use.

Code	Desc.	Payload (TON)	A H Min (mm)	B H Max (mm)	F. mm	Ø D mm	LxWxH (mm)	Weight Kg.
4700006050	2629	1,35	80	380	950	100	500x240x130	10

Spare Parts		
Article	Code	Description
COPPIA RULLI ANTERIORI	4700006850	2741/A
COPPIA RUOTE POSTERIORI	4700006860	2741/P
PIATTELLO IN GOMMA	4700006870	2741/T

## Lift trolley lowered short range capacity 2 Ton.



- Lowered Lift for use in heavy industry workshop.
- With its 70 mm dimensions without the plate it can also work on sports cars.
- With quick lift pedal.
- With nylon wheels are also suitable on delicate surfaces of exhibition halls.
- With compact handle and a safety system that prevents accidental opening of the descent valve.
- To open the valve must in fact slightly lift the handle and rotate it.
- **Hydraulic units guaranteed 3 years !!**

Code	Desc.	Payload (TON)
4700002320	2320F	2
4700002322	2322/R	Piattello in gomma

Tecnical Features	
Code	470000232
Minimum height (mm) with plate	89
Lunghezza x larghezza mm	720x370
Handle height mm	1060
Weight kg	37
H max (mm)	500
H min (mm)	70

## Hoist trolley 2 ton

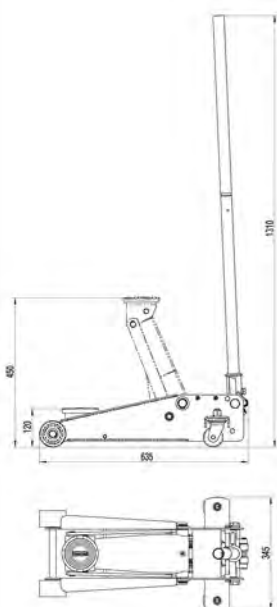

- With new double piston system for a fast approach to the load
- New structure which allows a weight saving of about 10 kg over the previous model
- With nylon wheels, ideal on all surfaces.
- With rubber pad inside a metal support in wear proof
- **Guaranteed hydraulic unit 3 years**

Code	Desc.	Payload (TON)
4700008340	4202	2

Tecnical Features	
Weight	29,5 Kg
Total height (mm)	1300mm
Dimensions	630x340mm
Maximum height	445mm
Minimum height	115mm

## 2.7 ton hoist trolley

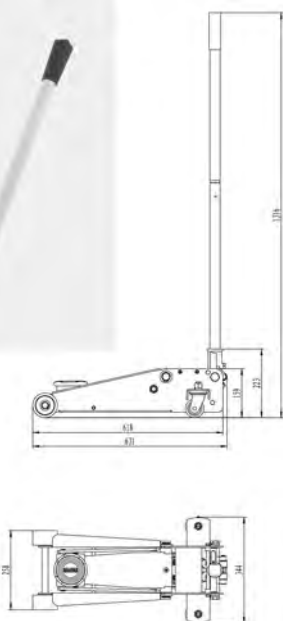

- With new double piston system for a fast approach to the load
- New structure which allows a weight saving of about 9 kg over the previous model
- Ideal for cars and vans
- With PU wheels, perfect on all surfaces.
- With rubber pad inside a metal support in wear proof
- **Hydraulic unit guaranteed 3 years**

Code	Desc.	Payload (TON)
4700008350	4203	2,7

Tecnical Features	
Minimum height	120 mm
Weight	32 kg
Total height (mm)	1315 mm
Dimensions	631x344 mm
Maximum height	450 mm

## Hydraulic jack 5 Ton.



- Hydraulic jack indicated for the lifting of machine tools or Forklift thanks to the particularly low foot (25mm only).

Code	Desc.	Payload (TON)	Min. H Foot mm	Max H Foot mm	Min. H head mm	Max H Head mm	Stroke Hydr. (mm)	Weight Kg.
4700007205	465/5	5	25	230	368	573	205	26,0

## Binda idraulica 8 Ton.



- Per il sollevamento sicuro di carichi pesanti
- Robusta struttura in acciaio saldato
- Velocità di abbassamento regolabile attraverso valvola di scarico
- Struttura piccola e compatta
- **Costruito secondo direttive CE**

Code	Desc.	Carico max sollevamento	Height min. (mm)	Stroke mm	Weight Kg.
4700007208	468-MH8	8 Ton.	20	140	28



## Lift for lift trucks and tractors

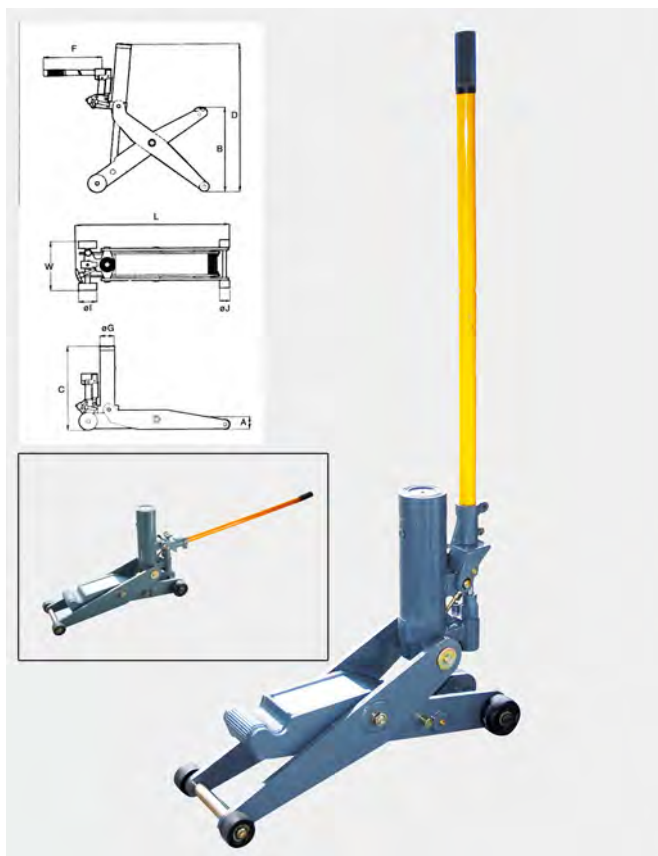

- Lifter combined with multiple properties.
- The extremely lowered front part is ideal for lifting of forklift trucks or machinery with a minimum ground clearance of 65mm and a max of 4 tons weight.
- The raised rear part allows the lifting of tractors and machinery with a minimum ground clearance of 415mm and a maximum weight of 5 tons.
- The piston walls and the lucid cylinder for longer life and less wear of the seals.
- Safety valve against overloading.
- Adjustable front plate (concave or convex) for optimal grip during the lifting.

Code	Desc.	Portata max ton
4700008080	813-T4/5	4 per carrelli - 5 per trattori

Technical Features	
W (mm)	240
L (mm)	790
ØI (mm)	100
C (mm)	415
D (mm)	765
F (mm)	750
ØJ (mm)	50
Peso Kg	45
Portata ant.	4
Portata post.	5
A (mm)	65
B (mm)	420
ØG (mm)	75

## Model short range



- Short range hydraulic lifter.
- Product suitable for workshops, tire, car wrecking, service stations and body shops.
- Remarkable maximum lift, equal to 525 mm, with static maintenance of the vehicle.
- Handle provided with descent system at dual safety system.
- Cast iron wheels, suitable for exteriors and interiors, and iron plate for added strength of the product.
- Article suitable for those wishing good payload and reduced size.
- Equipped with automatic safety valve that prevents loads superior to the nominal payload.
- Maximum payload: 1,5 Ton.
- The wheels in cast iron do not allow the sliding of grilling surfaces.

Code	Description	Payload (TON)	Max. width mm	Weight Kg.	A mm	B mm	C mm	D mm	E mm
4700006100	2630 - T 1,5 - sollevatore	1,5	365	37	1560	700	130	200	525

## Model short range dual wheels polyurethane 2 TON

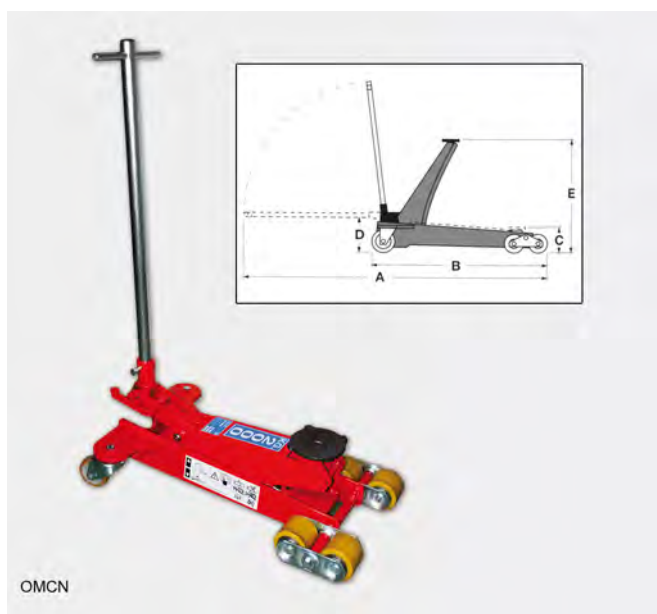

- Model short range dual wheels polyurethane 2 TON
- Product suitable for body shops, tire shops, car wrecking, and service stations.
- Remarkable maximum lift of 520 mm.
- Double front polyurethane wheels particularly suitable for gratings bodywork.
- Iron plate.
- Provide of automatic safety valve that prevents loads superior to the nominal payload.
- Max payload: 2 TON.

Code	Description	Payload (TON)	Max. width mm	Weight Kg.	A mm	B mm	C mm	D mm	E mm
4700006200	2631 PU - T 2 - sollevatore	2	530	45	1520	740	140	180	520

Spare Parts		
Article	Code	Desc.
Piattello in metallo	4700006202	2631/P
Manico completo	4700006204	2631/M
Coppia ruote posteriori	4700006220	2631/CP
Coppia ruote anteriori	4700006230	2631/A

## Model long range 3 TON



- Long series hydraulic lifter.
- Product suitable for workshops, tire, car wrecking, service stations and body shops.
- Remarkable maximum lift, equal to 520 mm, with static maintenance of the vehicle.
- Handle provided with descent system at dual safety system.
- Cast iron wheels, suitable for exteriors and interiors, iron plate for added strength. Product features for quick lift pedal.
- Equipped with automatic safety valve that prevents loads superior to the nominal capacity.
- Max Payload: 3 TON.
- The wheels in cast iron do not allow the sliding of grilling surfaces.

Code	Description	Payload (TON)	Max. width mm	Weight Kg.	A mm	B mm	C mm	D mm	E mm
4700006300	2632 - T3 - sollevatore	3	335	59	2100	1265	140	185	520

Spare Parts	
Code	Description
4700006310	2632M-Manico di ricambio

### Bottle oleopneumatic lifter



- Large payload lifter with pneumatic operation with compressed air from 6 to 12 bar, 300lt / minute (also from truck air intake).
- With the height adjustment screw.
- With two powerful springs that ensure the piston return.
- Particularly suitable for maintenance work on industrial vehicles and earth moving machines.

Code	Desc.	Portata max ton
4700003306	432020-T20	20

Tecnical Features	
Ingombro base	220X130
Screw stroke mm	80
Weight kg	16,6
Hydraulic stroke (mm)	145
H max (mm)	470
H_min (mm)	245
Code	4700003306
Portata Ton.	20

### Oleopneumatic lift extra short range



- Minimum encumbrance lift.
- Oleopneumatic lift mounted on the frame that facilitates its use and stowed vertically.
- Dual operation, air (pressure between 8 and 12 bar) and manual.
- Featuring plug-air japan range.
- With extension screw on the piston.
- Particularly suitable for mobile workshops due to low weight and practicality of use.

Code	Desc.	Payload (TON)
4700008060	811-T20	20

Tecnical Features	
Peso Kg	26
Larghezza mm	150
Lunghezza (mm)	420
H max (mm)	480
H_min (mm)	255
Code	4700008060



## Pneumatic elevators

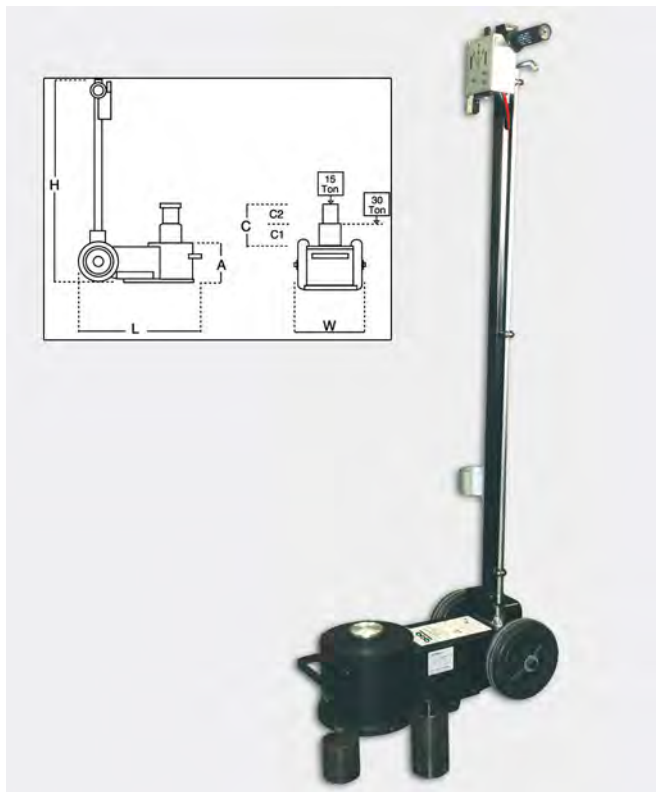

- Lifters with hardened and chrome plated piston for longer life and better protection of the seals.
- Hardened head for a secure and solid contact surface.
- The overload control system.
- Bypass system against the piston overextension.
- Pneumatic operation with compressed air from 6 to 12 bar, 300l / min.
- lockable handle tilted, vertically and horizontally.
- The model of 20 Ton has hardened expansion screw to adjust easily the height.
- Air attack Japan series.
- Particularly indicated in the V.I. workshop.

Code	Desc.	Portata max ton	Capacity (tonn)	A mm	B mm	C mm	C1 (mm)	C2 (mm)	L mm	W (mm)	H mm	Press. operating	Consumption air l/m	Weight Kg.
4700002708	2513-T15/30	15-30	15/30	170	340	190	70	120	525	300	1.400	6~12	300	41

## Oleopneumatic lift three extracts



- Professional lifter suitable for all uses heavy, especially repair and body shops of commercial vehicles, private bus companies, dealers industrial vehicles, earthmoving.
- The three modular extensions (10, 70 and 120 mm) are designed for precise approach to the base of the vehicle and a better exploitation of the hydraulic travel.
- The dual descent valve allows to have a constant speed under load and no-load increase.
- It equipped with a safety device that ensures the holding of the load even in case of accidental breakage of the air or oil pipes.
- Possibility to lock the handle in 3 different angles (vertical, inclined and horizontal), in order to operate in a practical and safe.
- To the maximum extent, the lift reaches a height of 540 mm
- Approved according to EN 1494.

Code	Desc.	H min (mm)	Stroke Hydr. (mm)	Length mm	H max (mm)	Weight Kg.	P (Bar)
4700002713	2513 - T18/30/60	150	66 + 56 + 63	730	1400	46	8 - 12



## Bench press 12 ton

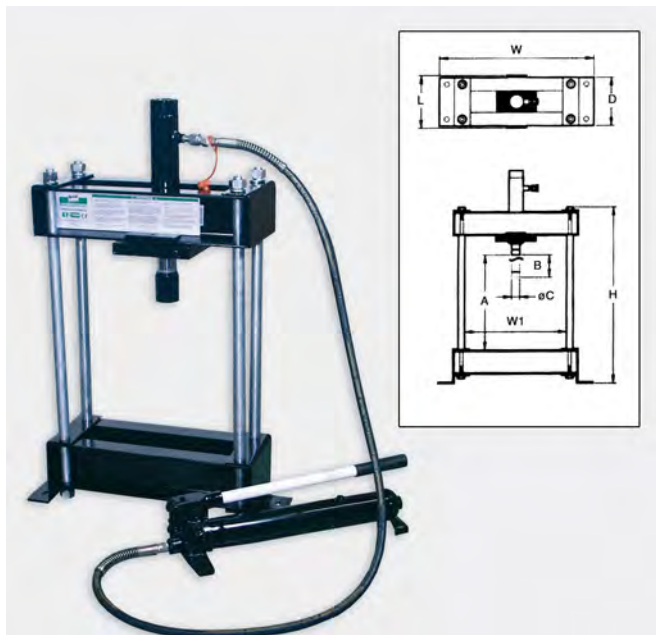

- Equipped with safety valve against overloading and piston overextension.
- Adjustable thrust unit position transversely to work in all relevant points.
- The power from 0 to 12 tons makes this machine a valid working tool and a valid support for all workshops.

Code	Desc.	Portata max ton	Capacity (tonn)	A mm	B mm	Ø C (mm)	D mm	H mm	L mm	W (mm)	W1 (mm)	Weight Kg.
4700002900	2517-T12	12	12	360	154	25	175	715	175	570	375	50

## Buffer and washers kit for bearings extraction



- Practical kit consists of a steel buffer and three washers with different diameter
- These tools allow the extraction of the hub bearings in combination with the bench press or similar and with the spacers.
- The buffer has a pusher function while the washers, depending on the diameter of the bearing, facilitate the task of increasing the contact surface.

Code	Desc.
4770002390	239

## Plates of supports to fork

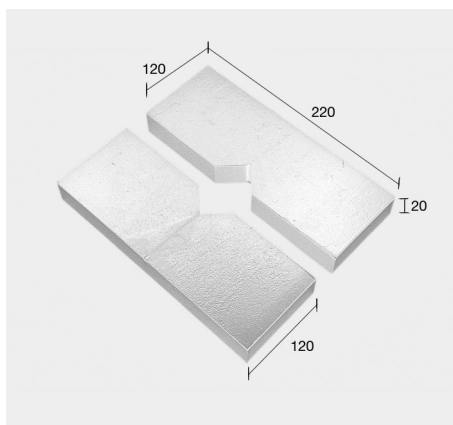

- Pair plates for support on the work surface.
- Allow, thanks to the central hollow, the retaining pieces with particular shapes or with pins.
- Essential for all owners of presses.

Code	Desc.	Dimensions
4700002905	2517P	220x120 H20

## Lifters underbridge and pit



Code	Desc.	Payload (TON)	H min (mm)	H max (mm)	Weight
4700002880	2516-T 0,3	0,3	1150	1960	30 kg
4700002890	2516-T 0,5	0,5	1150	1960	32 kg

Spare Parts		
Code	Description	Ton. Capacity
4700002851	Ruota con perno per 2516-T,03	0,3
4700002871	Ruota con perno per 2516-T,05	0,5

## Lifters underbridge and pit



- Hydraulic jacks for pits and underbridge.
- Product suitable for cars and V.I. workshops, wrecking, service stations and body shops.
- Highly professional articles provided with safety valve to overcharging.
- Max. payload 250, 600 and 1,000 kg for a wide range of applications.
- The overall dimensions of the base are contained for the convenience of the operator.
- The 250-kg model has a manual lowering system via knob placed on the lifter body. The other models are regulated by a hand lever.

Code	Desc.	Payload kg	Height min. (mm)	Piston stroke (mm)	Width base (mm)	Lunghezza base (mm)
4700006400	2633 - T.0,25	250	1.240	850	410	585
4700006500	2634 - T.0,6	600	1.180	780	520	520
4700006600	2635 - T.1	1.000	1.190	800	530	530
4700006602	2635 - T.2,5	2.500	1.350	870	550	550

Spare Parts	
Code	Description
4700006401	2633R Ruota di ricambio per 2633
4700006402	2633C Culla di ricambio per 2633
4700006605	2635C Culla di ricambio per 2635
4700006610	2635R Ruota ricambio per 2634/2635

## Columns rack



- Columns in printed and welded steel.
- With a safety device that prevents the accidental extraction of the support column.
- The columns are a fixed tool for the sustenance of the load and not performing any movement are not subject to CE certification - Safety coefficient of 2/1.
- For all repair and auto body shops.

Code	Desc.	Portata max ton	Capacity (tonn)	A mm	B mm	C mm	D mm	I mm.	J (mm)	L mm	W (mm)	Peso cad. (Kg)
4700002910	2518-T3	3	3	292	432	140	16	27	94	195	170	3
4700002920	2518-T6	6	6	390	618	228	18	32	110	270	230	5.8

## Columns plug



- Support columns with rectangular foot welded to the leg for a perfect stability on the ground.
- Locking system with through pin and safety chain.
- The robust design allows its use to support heavy loads up to 20 tons.
- For all garages and body shops V.I.
- The columns are a fixed tool for load support and not performing any movement are not subject to CE certification - safety factor 2/1.

Code	Desc.	Portata max ton	Capacity (tonn)	A mm	B mm	C mm	D mm	I mm.	J (mm)	L mm	N.W. (mm)	Peso cad. (Kg)
4700002950	2519-T12	12	12	485	750	265	53.0	95	130	315	23.5	11.8
4700002970	2519-T20	20	20	550	900	350	70.0	95	130	450	36.0	18



## Folding hydraulic crane



- Particularly suitable equipment for workshops that have space problems.
- Once used, the crane can be closed and placed vertically extremely safe thanks to the supports positioned at the base that ensure stability.
- With pumping high initial speed for a fast approach to the load.
- The speed decreases according to the load.
- Pumping unit is rotatable about 180 ° which allows the use also within an engine compartment by a single operator.
- The chrome-plated piston stem for greater durability.
- hydraulic unit security against accidental descent of the load system.
- With 4 positions of the arm that allows payload from 1000 to 500kg fully extended.
- Thanks to the front wheels nylon of large diameter, the crane can be moved outside.
- Equipped pre-assembled.
- Particularly suitable for car and motorcycle workshops.

Code	Payload (TON)	Description	Payload kg
4700008050	1	810-T 1,0	-
4700003670	-	2555 bil. carico	680 max

Spare Parts	
Code	Description
4700008100	810RP Rear wheel
4700008105	810RA Front wheel
4700008107	810RC Central wheel

Technical Features	
Code	4700008050
H min (mm)	300
H max (mm)	1940
Larghezza mm	460
Lunghezza (mm)	900
Peso Kg	71

## Tool for the sustenance of the engine.



- Universal tool for the sustenance of the engine.
- Suitable for car and V.I. workshops.
- Made of epoxy powder coated steel.
- Thanks to the many adjustments allows you to keep suspended the engine block without removing it completely and removing the organs attached to it quickly and accurately.
- Tilting support system to facilitate the fixing tool on the vehicle body.
- It equipped with two brackets with non-slip rubber feet to prevent damage to the bodywork.
- Complete with two threaded anchors and two chains to engage the engine and keep it in tension during the lifting of the vehicle.

Code	Description	Payload kg	Min. width mm	Max. width mm	Stroke mm	Weight Kg.
4700003680	2556 - Attrezzo solleva motore	500	950	1460	200	13

## Transpallet

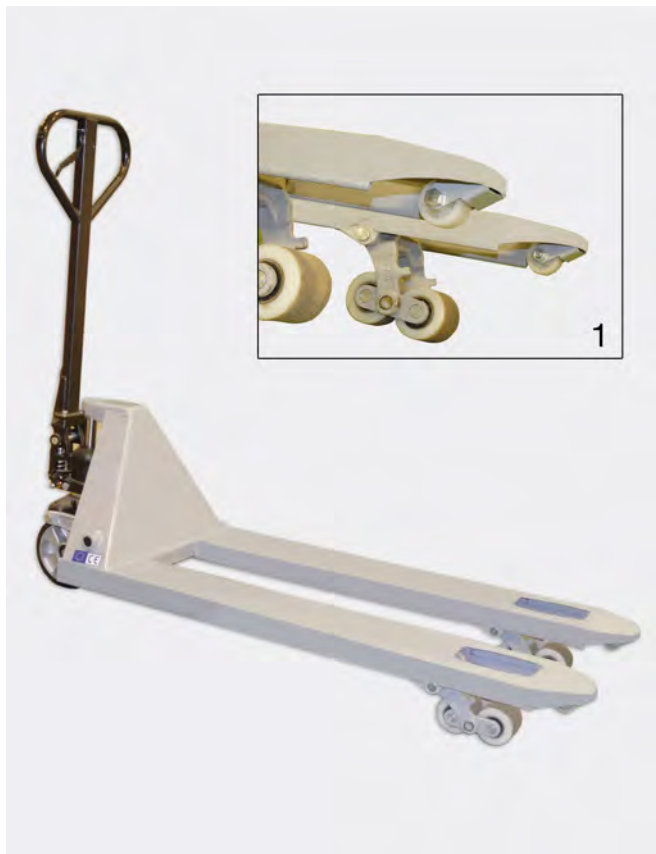

- Professional transpallet indispensable for the handling of materials.
- Indicated for workshops, hauliers and warehouses in general, service stations, couriers, etc..
- Dual front nylon rollers for a great smoothness and quietness even in the most delicate flooring.
- Under the forks (picture 1) there are two nylon rollers which facilitate the entry and the exit from the pallet.
- It equipped with grease fittings for easy maintenance.
- The powder painting provides a durable finish and quality.
- Complies with the Machinery Directive 2006/42 / EEC.

Code	Description
4700003390	2538
4700003391	2538 RA-Roller Ant.
4700003392	2538 RP-Ruota Post.

Tecnical Features	
Portata kg	2.000 kg
Forks min. height (mm)	85
Larghezza forche (mm)	550
Lunghezza forche (mm)	1.100
Larghezza forca (mm)	160
Weight kg	70
Total height (mm)	1.230
Forks max. height (mm)	195

## Mod. Car



- Universal carriage to moves cars.
- Particularly suitable for garages and body shops to maneuver car also crashed, as long as the wheels are intact.
- The solid rubber wheels with ball bearings enable you to use carriage in showrooms without any damage to the floor.
- Wide field of application, the trolley has indeed the ability to lift car with tires from 13" up to many profiles 16".
- With self-lubricating ball bearings.

Code	Description
3920000300	108 - Modello auto

Tecnical Features	
Rulli	Pvc antiurto ed autolubrificante
Ruote	4x100mm
Tire size	13" e molti profili da 16"
Portata	565 kg(2260kg con 4 unità)
Meccanismo	Doppia camma, cricco bi-direzionale
Larghezza max. pneumatico	Fino a 23 cm

## Mod. car and off-road vehicle



- Carriage for maneuvering cars and off-road vehicles, for tires with a maximum width of 32 cm.
- Using 4 units it's possible to lift 2820 kg well.

Code	Description
3920000310	109 L-SX Modello auto e fuoristrada
3920000311	109 R- DX Modello auto e fuoristrada

Tecnical Features	
Rulli	Acciaio nichelato
Portata	705 kg (2820 kg con 4 unità)
Meccanismo	Doppia camma, cricco bi-direzionale
Ruote	2x100mm+2x125mm
Tire size	Da 13" a 22"
Larghezza max. pneumatico	Fino a 32cm

## Side lift - lift Meccanocar



- Lifter electric Side lift particularly suitable for car bodies.
- It allows to raise obliquely cars and minivan of 2500 kg of total weight.
- The lift side - lift Meccanocar is practical to use, allows you to raise the machine easily and safely: it takes an operator and a few seconds.
- Possibility to work on the lower parts of the car in a handy position preventing backache and reducing fatigue.
- Unlike normal lifters that act directly on the frame, side-lift does not go to affect the plastic sills.
- The lifting via wheel allows the perfect alignment of the frame, and prevents the torsion of the same.
- Possibility to clean the bottom of car and apply the underbody protection in a simple, convenient way and without dirtying the operator.
- The oblique position of the car creates excellent lighting conditions to see imperfections on the body.
- Minimum dimensions and easy transportability make side-lift a practical product that solves space problems.
- possibility of front and rear lift or, with an accessory, also from the sill profile height of the rear-view mirror.
- mechanical lifting system with worm screw to ensure maximum safety of the product.
- Comes with fork for wheel and base for sill profile.(470 00 05050-2589/B) to use side - lift like a conventional column lift and extendable up to 70 cm (470 00 05100- 2589 / C) to operate in maximum security.

Code	Description	Photo
4700005000	2589 - Sollevatore Side Lift	1
4700005050	2589/B - Accessori per sottoporta	2
4700005100	2589/C - Colonnina di sicurezza	3

Spare Parts	
Code	Description
4700005030	2589/RP Ruota posteriore
4700005040	2589/RA Ruota anteriore (2 pezzi)
4700005005	2589/I Invertitore
4700005010	2589/M Motore side lift

Tecnical Features	
Larghezza interna forcella	430 (mm)
Supply voltage (v)	230
Protezione di contatto	Messa a terra totale
Protezione elettrica	IP 40
Max. capacity of wheel	18"
Tempo di elevazione	35 sec.
Elevation max. height	1 (mt)
Misure max (lxhxp)	680 X 1340 x 950 (mm)
Total weight	75 (Kg)



## BUFFERS FOR AUTO LIFT

### CARATTERISTICHE:

- Universal Meccanocar buffers: they fit perfectly with most major brands of auto fit available on the market.
- Constructed with ultra-resistant rubber.

### Buffer 1



- $\varnothing$  internal: 106 mm
- $\varnothing$  external: 148 mm.
- $\varnothing$  central hole: 12mm.
- Height: 31 mm.
- For auto lift OMCN 199

Code	Desc.
4430051900	1062

### Buffer 2



- $\varnothing$  external: 148 mm.
- $\varnothing$  central hole: 12 mm.
- $\varnothing$  internal: 116 mm.
- Height: 27 mm.
- For auto lift Ravaglioli

Code	Desc.
4430051910	1063

### Buffer 3



- $\varnothing$  external: 155 mm.
- $\varnothing$  internal: 136 mm.
- Height: 31 mm.
- For auto lift Ravaglioli

Code	Desc.
4430051920	1064

### Buffer 4



- $\varnothing$  external: 131 mm.
- $\varnothing$  internal: 110 mm.
- Height: 32 mm.
- For auto lift Ravaglioli

Code	Desc.
4430051930	1065

### Buffer 5



- $\varnothing$  external: 131 mm.
- $\varnothing$  internal: 108 mm.
- Height: 31 mm.
- For auto-lift OMCN/Ravaglioli

Code	Desc.
4430051940	1066

## Buffer 6



- $\varnothing$  external: 152 mm.
- $\varnothing$  central hole: 12 mm.
- $\varnothing$  internal: 132 mm.
- Height: 32 mm.
- For auto lift OMCN

Code	Desc.
4430051950	1067

## Rubber tile



- Length: 180 mm
- Width: 140 mm
- Height: 40 mm
- Possibility to join two rubber tiles through 4 bolts in such a way that to double the height of the tile.
- Minuteria not provided.
- Bolt recommended 10x45 galvanized white (ns. Art. 12600).
- Minuteria to be used::
  - N°4 - 1260004441 - 10x45x1,5
  - N°4 - 2080000700 - 10x15
  - N°8 - 2450000600 - 10

Code	Desc.
4430051960	1068

## Aluminum telescopic ladder



- Telescopic ladder as a support, adjustable.
- Anodized aluminum.
- Suitable for professional use
- **FEATURES:** minimum space during transport. Once it closed reaches a maximum height of 0.80 m, which allows it to be placed in any small space.
- Wide flight of stairs with non-slip tread rungs of 4 cm, which allows the operator to work in comfort 'and safety.
- Maximum height 3.80 m.
- Basic width ramp 49 cm width 45 cm top ramp.
- Non-skid pads to the lower extremities.
- Scala patented and produced in Italian legislation DPR 547, European standard EN 131, complies with the use according to the D. LGS. 626/94.



Code	Desc.	N. steps	Total height mt	Payload kg	Weight Kg.
4310003500		35	3,80	150	11,50

## Double ladder climb



PARTICOLARE ULTIMO GRADINO

- **Scale openable double ascent of industrial type, very robust, completely built in duralumin, with strap anti - opening safety.**

### Technical features:

- Scale professional duralumin.
- Double staircase climb shaped treads and non-slip profile.
- Safety strap tamper.
- Measures steps mm. 80x300.
- Total height mm. 1090.
- Overall width mm. 340.
- Raised mm steps. 250.
- Mm rectangular pillar. 70x20.
- Maximum working height mm. 2850.
- **Compliance with Italian DPR 547.**

Code	Description	N. steps	Total height mt	Payload kg	Weight Kg.
4310000800	10-ladder double ascent	4	1,09	150	5

## Universal telescopic ladder EN131



- Specifically designed with compact dimensions that help solve the difficult problems of transport and storage. It turns out to be particularly easy to handle as done in high-strength aluminum. Extremely versatile, it can be used as a stepladder, lame or countertop.
- Duralumin professional ladder.
- Made with non-slip steps to peg. section of the upper upright 68x25 mm, 77x26 mm lower mast section.
- Usable open, closed and extension of support.
- Conforming to European standard EN 131.
- Open "B"
- Closed "A"
- At extension "C".

Code	Desc.	N. steps	Height A mt	Height B mt	Height C mt	Width a mm	Width b mm	Payload kg	Weight Kg.
4310004150	64	(4+4)x2	1,29	2,05	4,28	338	630	150	12,40
4310004160	74	(5+4)x2	1,59	2,65	5,48	338	630	150	14,90



## Extensible ladders 3 items



- Industrial ladder elements which manages probably best to satisfy different user requirements that may arise. Its adaptability makes it either as a support level, a stool, or is a sliding scale. The absolute guarantee of safety is due to its all-aluminum structure consisting of non-slip rungs and amounts having passed the stress tests required by European standards. the devices provided by EN 131, the lateral rollover, accidental anti-sliding hook and anti-open / pinch protection, guarantee the maximum security.

### Technical data

- Ladder professional duraluminium.
- Ladder has skid bars.
- Complies with EN 131.
- Section bars 30x30 mm.
- Usable open, closed and sliding.
- Rectangular uprights 100x25 mm (4310001450 code).
- **Safety Certification EN 131.**

10



Code	Description	N. steps	Height A mt	Height B mt	Height C mt	Payload kg	Weight Kg.
4310001450	16/1-extendable ladder 3 elements	11X3	3,50	3,40	8,45	150	28,5
4310001400	16-extendable ladder 3 elements	6x3	1,98	1,90	3,80	150	14,8

## Universal ladder with platform and railing EN131



- Openable ladder with platform and railing.
- Aluminum made.
- Ideal for construction, assemblers, warehouse.
- The main features are the rail, the step tread with 130 mm, and the platform 270x250 mm polypropylene with safety catch.
- Step for a best supporting surface
- **Technical features:**
- professional aluminum ladder.
- Safety strap tamper.
- Platform size 270x250.
- Measure 130x30 mm steps
- Upright rectangular 70x20
- maximum load 150kg
- Conforming to European standard EN 131

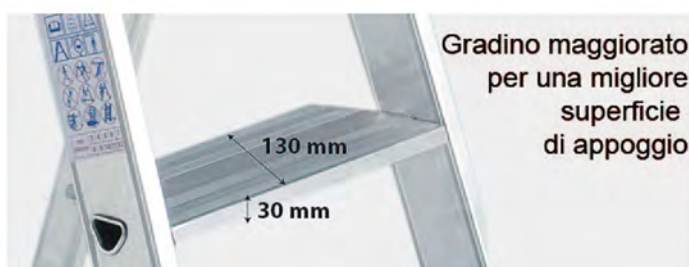

Code	Description	N. steps	Total height mt	Weight Kg.	Height platform mt	Width external of the base mm	Payload a kg
4310004190	90	6	2,01	8,50	1,37	540	150
4310004195	95	7	2,24	9,72	1,60	560	150

## Scaffolding mec22 h max 14,60 meters

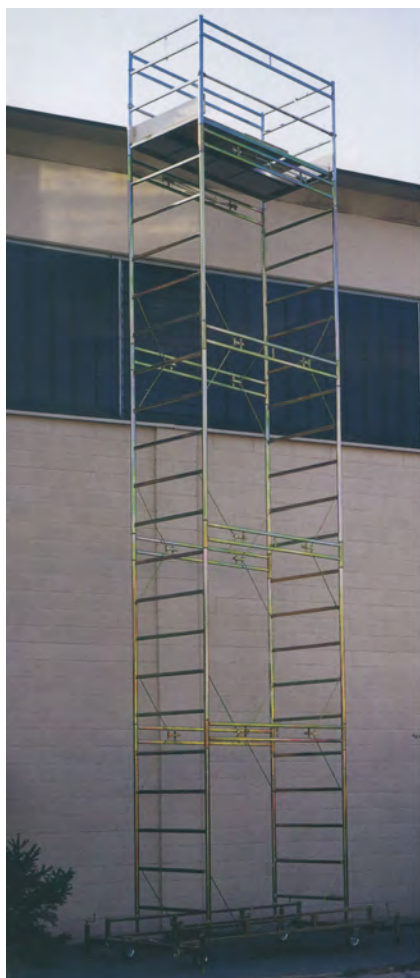

- **Completely disassembled, it does not create problems either for storage, or for transport. It differs in its domain for the extreme simplicity and ease of assembly. The heavy-duty has been specially designed to ensure maximum stability and safety even at high altitudes. The special treatment of galvanization to 8 micron medium to which it is subjected also ensures a long durability.**

**Technical features:**

- Rails made of tubular galvanized steel diam. 50 mm.
- Swivel wheels pivoting wheel diam. 200 mm.
- Basic dimensions, including stabilizers mt. 2,74x1,84
- Height alone basis mt. 0.44
- Height of each single span mt. 2.00
- Working surface dimensions mt. 1,97x1,06
- Capacity (including 2 people) kg. 200
- Approved according to European
- Maximum extent permitted mt. 14,60.

**Complete basic kg. 57:**

- Consisting of two side wheels.
- Complete with two stabilizer

**Complete basic kg. 35:**

- It consists of two elements each.
- Complete with two cross each.

**Span kg final. 28.5:**

- It consists of two elements from mt. 1.00.
- Final set.
- Complete with two railings.

**Accessories on request (\* not required):**

- Worktop full aluminum.
- Toeboards protection floor.
- Approval DPR 164 complete with instructions and rules of use.

Code	Description	Height mt	Weight Kg.
4310002000	20-BASED SCAFFOLDING	0,44	57
4310002100	21-SPAN SCAFFOLD M 2	2	35
4310002200	22-FINAL SCAFFOLDING M 1	1	28,5
4310002300	PLAN WORKING ALUMINIUM	-	30
4310002400	24-TOEBOARD SOF PROTECTION	-	6

## Scaffolding mec7 h max 8,50 meters



- **The scaffolding "MEC7" is the ideal tool for all types of maintenance: dall'imbiancatura cleaning, electricity from plant to plumbing. Its features, lightness and functionality, it provides the user with the stability and security needed to perform their jobs in absolute tranquility. The special treatment of galvanization to 8 microns average, which is subjected this scaffold, allows a long duration in time.**

- **Technical features:**

- Rails made of tubular galvanized steel diam. 42 mm.
- Swivel wheels pivoting wheel diam. 150 mm.
- Basic dimensions, including stabilizers mt. 2,31x1,54.
- Height alone basis mt. 0.23.
- Height of each single span mt. 1.50.
- Working surface dimensions mt. 1,74x0,90.
- Capacity (including 2 people) kg. 200.
- Approved according to European legislation.
- Maximum extent permitted mt. 8.50.

- **Complete basic kg. 30:**

- Consisting of two side wheels.
- Complete with two stabilizers.

- **Full span kg. 20:**

- It consists of two elements each.
- Complete with two cross each.
- 4 rods.

- **Span kg final. 20:**

- It consists of two elements from mt. 1.00.
- 4 rods end.
- 2 final.
- 2 railings.

- **Accessories on request (\* not required)**

- Worktop full aluminum.
- Toeboards protection floor.
- **Approval DPR 164 complete with instructions and rules of use.**

Code	Description	Height mt	Weight Kg.
4310003000	30- SCAFFOLDING BASE	0,23	30
4310003100	31-SPAN SCAFFOLDING MT. 1.5	1,5	20
4310003200	32-FINAL SCAFFOLDING MT. 1	1	20
4310003300	33- ALUMINIUM WORKING PLAN *	-	19
4310003400	34-TOEBOARDS OF PROTECTION *	-	5,2







## Antinfortunistica







Guanti .....	pag. 1334	Pronto soccorso .....	pag. 1368
Protezioni da cantiere e officina .....	pag. 1348	Segnaletica di sicurezza .....	pag. 1378

## Guanti di protezione

Guanti di protezione corrispondenti a quanto prescritto dalla direttiva 92/58/CEE - UNI 7543 - ISO 3864, cui fa riferimento il D.Lgs.493/96, trafuso nel nuovo D.Lgs. 81/08.

La certificazione identifica la normativa di sicurezza alla quale il guanto risponde ed e' esplicitata da una serie di valori che ne riassumono le performances. Ad un numero alto corrisponde un alto livello di prestazione.

Pittogrammi stampati su guanti conformi alla direttiva su i D.P.I. (Dispositivi di Protezione Individuale):

<b>CE</b>	Indica che il guanto risponde a delle esigenze di rischi minori ed intermedi, e che può circolare liberamente nel mercato europeo.
<b>CE 0000</b>	I guanti per rischi irreversibili o mortali, dopo il logo CE dovranno riportare un numero che identifichi l'ente che ha effettuato il controllo di qualità.
<b>Categoria I</b>	D.P.I. di disegno semplice per salvaguardare le persone da rischi fisici di lieve entità.
<b>Categoria II</b>	D.P.I. di disegno intermedio che salvaguarda l'operatore dai rischi medi.
<b>Categoria III</b>	D.P.I. di disegno completo, destinato a salvaguardare da rischi di morte, lesioni gravi e permanenti.
<b>EN 420</b>	Questa norma specifica i requisiti generali di ergonomia, realizzazione dei guanti, alta visibilità, innocuità, pulizia, confort ed efficienza, marcatura ed istruzioni. Si applica a tutti i guanti di protezione e ai guanti permanentemente contenuti, in contenitori chiusi. Non si applica ai guanti per elettricista e ai guanti chirurgici.
<b>EN 388</b>  <b>ABCD</b>	Guanti di protezione contro i rischi meccanici A) Resistenza all'abrasione da 0 a 4. B) Resistenza taglio da lama da 0 a 5. C) Resistenza alla lacerazione da 0 a 4. D) Resistenza alla perforazione da 0 a 4.
<b>EN 374</b> 	Guanti di protezione contro i rischi chimici
<b>EN 374</b> 	Guanti di protezione contro i rischi da microorganismi
<b>EN 374</b> 	Guanti di bassa protezione contro i rischi chimici
<b>EN 407</b>  <b>ABCDEF</b>	Guanti di protezione contro i rischi da calore e/o fiamma A) Resistenza all'infiammabilità da 1 a 4. B) Resistenza al calore da contatto da 1 a 4. C) Resistenza al calore convettivo da 1 a 4. D) Resistenza al calore radiante da 1 a 4. E) Resistenza a piccole proiezioni di metallo fuso da 1 a 4. F) Resistenza ad importanti proiezioni di metallo fuso da 1 a 4.
<b>EN 511</b>  <b>ABC</b>	Guanti di protezione contro i rischi da freddo A) Resistenza al fresco convettivo da 1 a 4. B) Resistenza al calore da contatto da 1 a 4. C) Impermeabilità all'acqua da 0 a 1.
	Guanto per uso alimentare.



## Mechanix Utility multipurpose gloves



- Multi-purpose technical gloves for a range of applications. Made with top-quality technical material, they are comfy, sensitive, breathable and stand out for exceptional durability, good fit and great comfort.
- Recommended for all work areas, from mechanics to body work, metal structural work, workshops for vehicle electricians, tyre fitters, construction and the installation of metal structures, etc.
- Made with palm in robust, dirt proof, synthetic leather. Back in breathable stretch fabric to keep hands cool and dry, even in very warm climates. Elastic wrist fastening with Velcro to keep the glove close fitting and allowing hand movement in the utmost comfort.
- Machine washable. Compliant with EN 388 standards with 3131 protection grade.



Code	Desc.	Taglia
4460000408	8717S	7-S
4460000410	8717M	8-M
4460000420	8717L	9-L
4460000430	8717XL	10-XL
4460000435	8717XXL	11-XXL

## Leather gloves flower



- Leather Gloves flower calf.
- White, does not stain the skin.
- Tighten internal elastic wrist.
- Ideal for various jobs in the workshop and to maneuver pieces dry.
- A CE cat. II.

Code	Desc.	Taglia
4460000348	8715/8	M
4460000350	8715/9	L
4460000355	8715/10	XL
4460000360	8715/11	XXL



## Guanti in pelle fiore



- Guanti in pelle fiore di vitello.
- Colore bianco, non macchia la pelle.
- Stringipolso elastico interno.
- Ideali per lavori vari in officina e per manovrare pezzi asciutti.
- A norme CE cat. II.

Code	Desc.	L mm	Taglia
4460000289	8602-8	240	8
4460000290	8602-9	240	9
4460000300	8602-10	240	10
4460000305	8602-11	240	11

## Grain leather gloves padded



- Gloves grain leather calf.
- White, does not stain the skin.
- Tighten internal elastic wrist.
- Ideal for various jobs in the workshop and to maneuver any piece dry.
- Interior padding sweatshirt.
- Recommended in cold places.
- In accordance with CE cat. II.

Code	Desc.	Length mm	Taglia
4460000270	8601-9	240	9
4460000280	8601-10	240	10
4460000283	8601-11	240	11

## Grain leather and cotton gloves



- Grain leather and cotton gloves.
- White, does not stain the skin.
- Back and cuff in cotton.
- Suitable for handling crates, cartons, storage operations, loading and unloading.
- Ideal for all general maintenance.
- Glove with palm, thumb and saves nails, leather.
- In accordance with CE cat. The only minimal risks.

Code	Desc.	Length mm	Taglia
4460000250	8600-9	240	9
4460000260	8600-10	240	10

## Grain leather and cotton gloves with Velcro



- Work gloves pig grain leather cotton back.
- Suitable for handling crates, cartons, storage operations, loading and unloading and for all maintenance in general.
- Velcro closure can be easily adapted to any size of wrist, which guarantees a secure closure with some added comfort.
- Excellent sensitivity '.
- Glove size 8 comes in red, yellow for the other two measures.
- A CE cat. I.

Code	Desc.	Taglia
4460018940	19675/M	8-M
4460018950	19675/L	9-L
4460018970	19675/XL	10-XL
4460018980	19675/XXL	11-XXL

## Gloves in crust and canvas



- Gloves in cowhide split.
- Back in denim and canvas hose.
- Elastic on the back.
- For their convenience they are suitable for general work and highly appreciated by dispatchers and storekeepers.
- A CE cat. I.

Code	Desc.	L mm	Taglia
4720008100	192	270	10

## Gloves crusted veal



- Gloves all entirely crusted veal.
- Palm and reinforced thumb.
- Hose of 15 cm.
- Ideal for carpentry work.
- A CE cat. I.

Code	Desc.	L mm	Taglia
4460000310	8603	260	10

## Gloves in crust for welders



- Split leather gloves for welders.
- Felt-lined cotton fabric.
- With saves seams.
- A CE cat. I.
- Product suitable for welding, foundry, handling of metallurgical products.

Code	Desc.	L mm	Taglia
4460007400	4017	320	10

## Guanti anticalore in poliestere rivestiti in nitrile 250°C



- Guanti anticalore in tessuto jersey di cotone e poliestere con interno in feltro di poliestere, spalmatura esterna in nitrile antiscivolo. Ideali per lavorazioni con oggetti caldi fino a +250°C.
- Comodissimi e molto protettivi, adatti per lunghi tempi di lavorazione. Indicati per le industrie dello stampaggio della plastica e del vetro, forni industriali, industria metallurgica, fonderie, acciaierie, manipolazione di stampi e di lastre metalliche, lavorazioni a contatto con materiali taglienti e abrasivi.
- Offrono, oltre all'isolamento dal calore da contatto, anche una buona presa e buone caratteristiche antistrappo ed anti abrasione. La lunghezza della manichetta permette di proteggere efficacemente anche gli avambracci.

Code	Description	L mm	Taglia
4460000480	Guanti WT	350	10

## Guanti anticalore in Kevlar® e cotone 350°C



- Guanti anticalore in filo continuo di Kevlar® esterno e cotone interno, che offrono un'eccezionale resistenza al taglio, alla lacerazione, all'infiammabilità e al calore da contatto.
- Comodissimi e molto protettivi, adatti per lunghi tempi di lavorazione. Indicati per le industrie dello stampaggio della plastica e del vetro, forni industriali, industria metallurgica, fonderie, acciaierie, manipolazione di stampi e di lastre metalliche, lavorazioni a contatto con materiali taglienti e abrasivi anche in presenza di oli e grassi. Idonei per la protezione dalla fiamma viva.
- L'assenza di cuciture nei punti di sforzo li rende estremamente confortevoli ed evita ogni irritazione, oltre ad evitare rotture premature dei guanti. La

Code	Description	L mm	Taglia
4460000490	Guanti KW	340	10

## Nitrile gloves heavy ventilated back



- Ventilated back.
- Excellent resistance to abrasion and cutting.
- Good hygiene guaranteed by the processing performed on the cotton lining.
- Version with cotton back and cuff canvas.
- The nitrile coating is not altered in the presence of oils and fats.
- Ideal for machining in the mechanical / Built.
- A CE - Cat. II.

Code	Desc.	L mm	Taglia
4460006810	4001	250	9

## Guanti in nitrile pesante interamente spalmati



- Interamente spalmati
- Ottima resistenza all'abrasione, idrocarburi e derivati, oli e grassi
- Con trattamento antibatterico Sanized R( Registrato)
- Manichetta di sicurezza in tela di cotone
- A norme CE cat II

Code	Desc.	L mm	Taglia
4460006815	4002/9	260	9

## Nitrile fully coated heavy



- Entirely coated.
- Excellent resistance to abrasion and cutting.
- Good hygiene guaranteed by the processing performed on the cotton lining.
- Canvas cuff.
- The nitrile coating is not altered in the presence of oils and fats.
- Ideal for machining in the mechanical / Built and for use in the food industry.
- A CE cat. II.

Code	Desc.	L mm	Taglia
4460006820	4002	260	10



## Nitrile gloves



- Nitrile gloves with cotton interlock lining.
- Lightness and maneuverability.
- Free of silicones.
- Ideal for work in the workshop, in light carpentry, the packaging sector, in the public services, the shippers.
- A CE cat. II.

Code	Desc.	L mm	Taglia
4460007430	4020	235	9

## Nitrile gloves light



- Excellent abrasion resistance as well as greases and oils.
- Model with ventilated back to the breathing of the hand.
- Elasticized wrist.
- Free of silicones, ensure absolute cleanliness in metalworking.
- Ideal for work in the workshop, building, cleaning companies, plumbing and carpentry.
- A CE - CAT. II.

Code	Desc.	L mm	Taglia
4460006830	4003-S	270	8
4460006840	4004-M	270	9
4460006850	4005-L	270	10

## Gloves coated with nitrile palm gray



- Gloves polyester back with the palm and fingertips coated with nitrile.
- Particularly suitable in the field of plumbing, mechanics, carpentry, maintenance, electronics, components and construction.
- The light coat nitrile glove on the hand gives the user a high dexterity.
- Highly breathable glove on the back and high resistance break.
- In accordance with CE cat. II

Code	Desc.	Taglia
4460030810	32250 - S	7/S
4460030820	32250 - M	8/M
4460030830	32250 - L	9/L
4460030840	32250 - XL	10/XL

## Nitrile gloves coated with black palm



- Gloves back in nylon with palm and fingertips lightly coated with nitrile.
- Ideal for the plumbing industry, mechanics, carpentry, maintenance and construction.
- Highly breathable glove on the back and considerable resistance on the palm.
- The coated nitrile black favors the grip and abrasion resistance.
- A CE cat. II.

Code	Description	Taglia	Length mm
4460019370	19720-M-smearred NITRILE GLOVE BLACK	8	240
4460019380	19720-XLQUANTO smearred NITRILE BLACK	9	240
4460019390	19720-XL-smearred NITRILE GLOVE BLACK	10	240



## Polyurethane coated gloves gray



- Gloves with palm coated in polyurethane and knit back.
- Particularly suitable in the fields of assembly, mechanical maintenance, mechanical precision.
- Aerated back to improve breathability of the hand, elastic wristband finished in different colors depending on the size.
- Product specially created for maximum strength and remarkable sensitivity 'than reusable gloves.
- A CE cat. II.

Code	Description	Taglia	Leng. mm
4460019340	19710-M-smearred GLOVE POLYURETHANE GREY	8	240
4460019350	19710-L-smearred GLOVE POLYURETHANE GREY	9	240
4460019360	19710-XL-smearred GLOVE POLYURETHANE GREY	10	240

## Gloves coated in polyurethane



- Knitted glove built with continuous filament nylon.
- Ventilated back to minimize perspiration.
- Wrist and back stretch.
- Palm coated in polyurethane.
- Use sectors: assembly workshops mechanics, precision mechanics, maintenance assembly.
- The special elasticity of the glove allows a sensitivity superior to all reusable gloves.

Code	Desc.	Taglia	Leng. mm
4460010010	4339-M	8/M	240
4460010020	4339-L	9/L	240
4460010030	4339-XL	10/XL	240

## Guanti antitagliosalmati poliuretano



- Guanto in filo continuo di fibra aramidica con spalmatura sul palmo in poliuretano.
- Ideale per la protezione delle mani contro oggetti taglienti e spigoli vivi.
- Settori di utilizzo: lavorazioni metalliche, manutenzione, falegnameria, vetreria, impiantisti, carrozzerie, officine meccaniche, manipolazione oggetti taglienti.
- Guanto morbido ed elastico, studiato appositamente per offrire il massimo comfort e protezione nelle lavorazioni.
- La completa assenza di cuciture nei punti di maggiore sforzo salvaguarda la pelle da eventuali irritazioni.

Code	Desc.	Measure
4460030540	32120-S	7/S
4460030545	32120-M	8/M
4460030550	32120-L	9/L
4460030555	32120-XL	10/XL

## Coated cut-resistant gloves of polyurethane Plus



- Cut-resistant gloves made of Aramid fibre continuous filament, with polyurethane waterproof coating slip-resistant on the palm. Extremely cut-resistant (level 5, the highest possible).
- Suitable for hand protection from sharpened objects and sharp edges.
- Application sectors: metal processing, maintenance, joinery, glasshouses, installers, body shops, mechanical workshops, handling of sharp objects.
- Soft and elastic gloves, especially designed to offer the utmost comfort and protection during processing. The complete absence of seams in the points of maximum stress protects the skin from irritations.
- In compliance with CE cat. II.

Code	Desc.	Measure
4460001220	3947/7	S/7
4460001230	3947/8	M/8
4460001240	3947/9	L/9
4460001250	3947/10	XL/10

## Cut resistant gloves latex



- Polyester cotton glove with latex coated palm.
- To be used to protect the operator from cutting elements, glass, foils.
- Intended Use: glaziers, window fitters, sheet metal, assembly.
- Benefits: ventilated back and wrist stretch.
- Treaty to protect the user from bacteria and microbes.
- Under EC CAT.II

Code	Desc.	Taglia
4460027355	32105/7	S
4460027360	32105/8	M
4460027365	32105/9	L
4460027370	32105/10	XL

## Cut resistant gloves latex prevent



- Cotton gloves with latex coated palm.
- To be used to protect the operator from cutting elements, glass, foils.
- Intended Use: glaziers, windows, plumbing, assembly, construction, structural steel work.
- Benefits: ventilated back and wrist stretch.
- Reinforced between thumb and forefinger.
- Treaty to protect the user from bacteria and microbes.
- In accordance with CE cat. II.

Code	Desc.	Taglia
4460027390	32110/10	XL

## Cotton gloves



- Cotton gloves continuous thread.
- Hemmed at the bottom.
- Extremely sensitive.
- Ideal for inspection, assembly lines and light work and clean.
- A CE cat. 1.

Code	Desc.	L mm	Taglia
4460007410	4018	230	8 - 9

## Gloves antivibration



- Cotton gloves and nylon with anti-vibration coating. Perfect.
- Particularly suitable for the area of carpentry, the frame, plant, workshop and construction. For use with electric and pneumatic tools that emit strong vibrations, such as: hammer drills, hammers, sanders, impact wrenches.
- Palm coated by a special support chloroprene which absorbs effectively the vibrations to the hand.
- Comply with the requirements of EN ISO 10819: 1996 for the prevention of risks of exposure to hand-arm vibration.
- In accordance with CE - Cat. I.

Code	Desc.	Taglia
4460030480	32065/9	L

## thermal gloves



- Gloves yarn acrylic-nylon and foam composite, without seams.
- Particularly suitable for working storage, shipping, hydraulic, assembly, building and in cold storage. Suitable for food contact
- Internally lined with elasticized wrist.
- Palm coated with a special compound foam with water-repellent treatment that ensures a perfect grip in both wet and dry conditions.
- Specially designed to withstand the cold and contact with objects at room temperature until -50 °. Able to prevent the spreading of heat from hands.
- In accordance with CE - Cat. I.

Code	Desc.	Taglia
4460030460	32045/8	M
4460030465	32045/9	L
4460030470	32045/10	XL
4460030475	32045/11	XXL

## Nitrile gloves



- Excellent resistance against chemical and mechanical resistance.
- Exceptional flexibility '.
- Excellent resistance to abrasion and puncture.
- Great entry, plush lining.
- It contains fungicidal and bacteriostatic agent that preserves the hygiene of the hand.
- Ideal for chemical, automotive, machine shop, automotive, machining.
- In accordance with CE - Cat. III.

Code	Desc.	L mm	Taglia
4460008530	4200-M	330	8
4460008535	4200-L	330	9
4460008540	4200-XL	330	10

## PVC gloves



- PVC coated glove.
- To be used to protect the operator from chemicals and microorganisms.
- Intended Use: mechanical, chemical, refineries, recycling, waste collection.
- Benefits: cotton lined interior.
- Antibacterial treatment.
- Waterproof.
- Excellent abrasion resistance.
- In accordance with CE cat. III.

Code	Desc.	L cm	Photo	Taglia
4460027400	31115	35	A	10 - XL
4460027410	31120	58	B	10 - XL

## 60 cm knurled rubber gloves



- Gloves of pure natural latex (rubber) with slip-resistant knurled palm and back, smooth inside, total length 60 cm, with antidrip hem.
- Indicated for the following working sectors: building and installation of ceramic, handling of slippery, sharp objects, sandblasting, dismantling of vehicles, waste collection.
- Featuring high mechanical strength and slip-resistant. Suitable for processing slippery parts and for cleaning extremely dirty and greasy material.
- Good shear and perforation strength, high elasticity of the material.

Code	Desc.	Taglia
4460042095	32370/10	XL

## Nitrile gloves Standard Meccanocar



- Ambidextrous gloves nitrile disposable.
- Wholly nitrile, latex, with pulverization and internal light rough finish to allow a better grip of objects.
- Packed in practical dispenser 100 pieces.
- Quality Standard AQL 1.5.
- Complying with EN 455 1 and 2.



CE EN 455 1 & 2  
AQL 1,5



Code	Desc.	Taglia	Leng. mm
4460021000	24000/M	8/M	240
4460021010	24000/L	9/L	240
4460021020	24000/XL	10/XL	240



## Nitrile gloves standard powder



- Disposable glove SYNTHETIC NITRILE light blue, beaded ambidextrous, powder free.
- Indicated in all employment sectors, from mechanical industry, crafts. Suitable for contact with foods, and can be used in all areas of the food industry.
- High sensitivity, dexterity and comfort. Fingertips to non-slip palms. Chemical resistance to detergents and cleaners also concentrated, hydrocarbons, solvents, ethers and freon (TF). Good mechanical strength to the glove disposable latex / vinyl.
- Disposable multipurpose controlled quality AQL 1.5 (freedom from holes) for long-term use to protect the hand and / or the product handled. High biocompatibility (free from natural latex).
- Recommended for people allergic to latex.

Code	Desc.	Taglia
4460000370	8716-S	S/6-6,5
4460000375	8716-M	M/7-7,5
4460000380	8716-L	L/8-8,5
4460000385	8716-XL	XL/9-9,5

## Guanti usa e getta in nitrile “Grease Monkey”



- Guanti in nitrile usa e getta dalla costruzione robusta e dalla resistenza altissima, dotati di un'ottima presa, una comodità ineguagliabile e, grazie alla completa assenza di lattice, assolutamente sicuri per le persone allergiche al contatto con tale materiale. Non contengono talco.
- Indicati per lavorazioni a contatto con superfici umide o oleose: assemblaggi e manutenzioni, autofficine, autocarrozzerie, carpenterie meccaniche, metalliche, costruzioni e montaggi di strutture metalliche. Conformi anche per l'utilizzo nel campo alimentare.
- Il tipo di nitrile utilizzato permette di avere alti spessori sia sul palmo sia sulle dita, mantenendo un'elevata flessibilità ed un grado di destrezza massimo, la superficie di dita, palmo e dorso con la speciale finitura in rilievo a squama di pesce permette una presa sicura sui materiali scivolosi, una leggera rugosità interna garantisce la migliore aderenza del guanto alla mano.
- Forniti in dispenser di cartone, dotati di bordino salvagoccia sul polsino. Indice AQL 1,5.

Code	Desc.	Taglia
4460000440	8718M	8 - M
4460000450	8718L	9 - L
4460000460	8718XL	10 - XL
4460000470	8718XXL	11 - XXL

## Blacks nitrile gloves standard without powder



- Disposable glove SYNTHETIC NITRILE black, beaded ambidextrous, powder free. The special compound makes them very flexible and resistant to tearing.
- Indicated in all employment sectors, from mechanical industry, crafts and in the medical industry as non-sterile glove.
- High sensitivity, dexterity and comfort. Fingertips to non-slip palms. Chemical resistance to detergents and cleaners also concentrated, hydrocarbons, solvents, ethers and freon (TF). Good mechanical strength to the glove disposable latex / vinyl.
- Disposable multipurpose controlled quality AQL 1.5 (freedom from holes) for long-term use to protect the hand and / or the product handled. High biocompatibility (free from natural latex).
- Recommended for people allergic to latex.

Code	Desc.	Taglia
4460000140	7119-S	S/6-6,5
4460000150	7119-M	M/7-7,5
4460000160	7119-L	L/8-8,5
4460000170	7119-XL	XL/9-9,5

## Nitrile gloves Plus Meccanocar



- Nitrile disposable gloves ambidextrous not pulverized.
- Wholly nitrile, latex, light rough finish to allow a better grip of objects.
- High resistance to oils, grease, hydrocarbons and some solvents.
- The thickness and the material used make the gloves extremely resistant and durable.
- Packaged in convenient dispenser of 50 pieces.
- Quality Standard AQL 1.5.
- Complying with EN 455 1 and 2.

Code	Desc.	Taglia	Leng. mm
4460021100	24100/M	8/M	240
4460021110	24100/L	9/L	240
4460021120	24100/XL	10/XL	240

## Nitrile disposable gloves Ansell Touch N Tuff ®



- Nitrile ambidextrous.
- Treated with powdered version.
- Protection against chemical irritants.
- Ideal for workshops, body shops, fuel pumps.
- A CE cat. III.
- In accordance with EN 374.

Code	Desc.	L mm	Taglia
4460008570	4202-M	240	8
4460008575	4202-L	240	9
4460008577	4202-XL	240	10

## Disposable vinyl gloves



- Vinyl gloves ambidextrous highly sensitive 'i'.
- Contain no talc to avoid contaminating the products.
- Inside treated with powdered version.
- Ideal for body shops, handling of Plexiglas, precision assembly, inspection work, suitable for the food industry, essential in the handling of paints, dyes, glues and resins
- Solvent resistant.
- A CE cat. III.

Code	Desc.	L mm	Taglia
4460007420	4019-L	235	8 - 8 1/2
4460007425	4019-XL	235	9 - 9 1/2

## Latex gloves shimmed caql 1.5



- Protective gloves disposable latex rubber, high thickness and increased length for maximum protection from chemical and mechanical hazards. Dust free and treated for minimizing the risk of allergies.
- Suitable for use in body shops, machine shops, in the area of maintenance and professional cleaning, industrial processes, in contact with hydrocarbons and food.
- Roughened externally for a good grip, high durability and protection, high resistance to mechanical stress and hydrocarbons, acids and bases.
- Supplied in dispenser box of 50 pieces.

Code	Desc.	Taglia
4460031050	32355M	8
4460031055	32355L	9
4460031060	32355XL	10
4460031065	32355XXL	11

## Standard latex gloves without powder



- Disposable glove of natural latex, milky white, beaded ambidextrous, powder free.
- Indicated in all employment sectors, from mechanical industry, crafts and in the medical industry as non-sterile glove. Suitable for contact with foods, and can be used in all areas of the food industry.
- High sensitivity, dexterity and comfort. Fingertips to non-slip palms. Chemical resistance to detergents and cleaners also concentrated acids and bases. Good mechanical strength and high elasticity.
- Disposable multipurpose controlled quality AQL 1.5 (freedom from holes) for long-term use to protect the hand and / or the product handled.

Code	Desc.	Taglia
4460000180	7120-S	S/6-6,5
4460000190	7120-M	M/7-7,5
4460000200	7120-L	L/8-8,5
4460000210	7120-XL	XL/9-9,5

## Disposable latex gloves with talc



- Guanto monouso in lattice naturale, di colore bianco latte, ambidestro con bordino, trattato internamente con polvere di amido vegetale.
- Indicato in tutti i settori lavorativi, dalla meccanica all'industria, all'artigianato e nel settore medico come guanto non sterile. Idonei al contatto con alimenti, e utilizzabili in tutti i campi del settore alimentare.
- Elevata sensibilità, destrezza e comfort. Punta delle dita a superficie ruvida antiscivolo. Resistenza chimica a detersivi e detergenti anche concentrati, acidi e basi. Buona resistenza meccanica ed elevata elasticità.
- Monouso polivalente di qualità controllata AQL 1.5 (per assenza di fori) per utilizzi di lunga durata a protezione della mano e/o del prodotto manipolato.

Code	Desc.	Taglia
4460004790	3983-S	S/6-6,5
4460004795	3983-M	M/7-7,5
4460004800	3983-L	L/8-8,5
4460004810	3983-XL	XL/9-9,5



## Helmet for work at height



- Helmet in ABS, light and ergonomic.
- Suitable for carrying out work at height, including the erection of scaffolding.
- It equipped with harness with fabric fasteners to six points that conforms to the shape of the head and ensures optimal comfort.
- With sweatband.
- And adjustable padded chin strap with quick release. Designed to limit the risk of losing the helmet in case of impact during a fall.
- The absence of visor increases the field of vision upwards.
- One size from 53 to 61.
- Weight 460 grams.
- White color.
- Conforming to European standard EN 397. It responds also to the optional extension of EN 397 on lateral deformation.

Code	Desc.
4460030485	32070

## Helmet dielectric construction



- Protective helmet construction High density polyethylene, dielectric protection up to 400 volts.
- Shaped at the top for greater impact resistance, with internal adjustable headband and sweatband.
- Intended Use: construction, demolition, construction of hydraulic, maintenance and construction elevators, shipbuilding, on large reservoirs, etc.
- One size adjustable from 53 to 62.
- Chinstrap universal available separately.
- Weight 332 grams.

Code	Description	Color
4720008000	191/G	Yellow
4720008010	191/B	White
4720008020	191/R	Orange
4720008030	191/A	Light blue
4720008040	191/RO	Red
4720008041	191 S/RO - CHINSTRAP FOR RED HELMET	-
4720008050	191/S - CHINSTRAP	-

## Half helmet abs



- Half helmet ergonomic adjustable (photo 1).
- Use sectors: carpenters, blacksmiths, fabricators, installers, maintenance personnel, building, body shops, mechanical industries, etc.
- With the upper band for adjusting the height of the cap.
- Adjusting the head circumference (53 to 61 cm).
- Visor folding of 90 °. Headband sweat sponge.
- half helmet sold separately from polycarbonate visor (photo 2). Combined with the visor and 'ideal for repairing the operator's face by mechanical impacts, liquids and dust (picture 3).
- Compliant to EN 166 generic protection

Code	Desc.	Article
4460031030	32335	Half helmet polypropylene (photo 1)
4460031035	32340	Vis. Prot. L395 x H.200 x 1mm thick (3 photos)

## Ear muffs 27 dB



- Headphones anti-noise polypropylene.
- Extra-lightweight, weight 127 gr.
- Excellent level of attenuation.
- A standard EN 352-1.

Code	Desc.
4720007700	188

TABELLA DI ATTENUAZIONE

SNR = 27 dB	H = 33 dB		M = 15 dB				L = 16 dB	
FREQUENZA IN Hz	125	250	500	1000	2000	4000	8000	
ATTENUAZIONE MEDIA (Mf) IN dB	12.9	15.2	24.8	34.2	32.0	36.1	28.4	
DEVIAZIONE STANDARD (Sf) IN dB	3.0	2.0	3.1	3.1	3.1	2.9	3.7	
PROTEZIONE PRESUNTA (APVf) IN dB	9.9	13.2	21.7	31.1	28.9	33.2	24.7	

## Ear muffs 29 dB

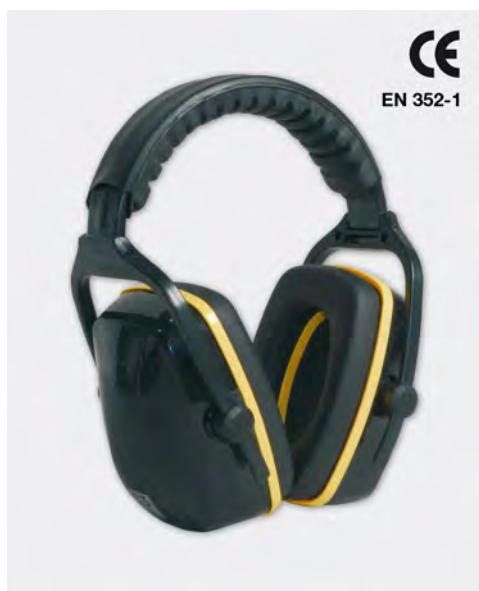

- Headphones noise in ABS, light and comfortable.
- Industry: carpenter, carpenters, all building trades, general industries, building sites and road ..
- Advantages: headband with anatomical padding, only 230 gr.
- Cups for ears very comfortable equipped with internal foam, height adjustment.
- Complies with EN 352-1. DPI Class II.

Code	Desc.
4460027430	31123

TABELLA DI ATTENUAZIONE

SNR = 29 dB	H = 34		M = 26				L = 18	
FREQUENZA IN Hz	125	250	500	1000	2000	4000	8000	
ATTENUAZIONE MEDIA dB	14.0	15.2	23.6	32.1	33.1	37.2	31.7	
LIMITE dB	5	8	10	12	12	12	12	

## Earplugs expansion 37 dB



- Earplugs expanding polyurethane foam hypoallergenic.
- They model themselves easily to all ducts earphones.
- High comfort, one size, and 'possible reuse.
- Attenuate ambient noise of 33 dB, leaving, however, perceive the spoken.
- Conforming to European standard EN 352-2.

Code	Desc.
4460007440	4021

TABELLA DI ATTENUAZIONE

SNR = 37 dB	H = 36 dB		M = 34 dB				L = 33 dB	
FREQUENZA IN Hz	63	125	250	500	1000	2000	4000	8000
ATTENUAZIONE MEDIA (Mf) IN dB	28.4	37.3	37.9	39.1	36.0	34.6	42.5	46.4
DEVIAZIONE STANDARD (Sf) IN dB	6.4	9.0	9.2	9.7	7.9	4.6	4.9	4.7
PROTEZIONE PRESUNTA (APVf) IN dB	22.0	28.3	28.7	29.4	28.1	30.0	37.6	41.7

## Earplugs expansion with cord 32 dB

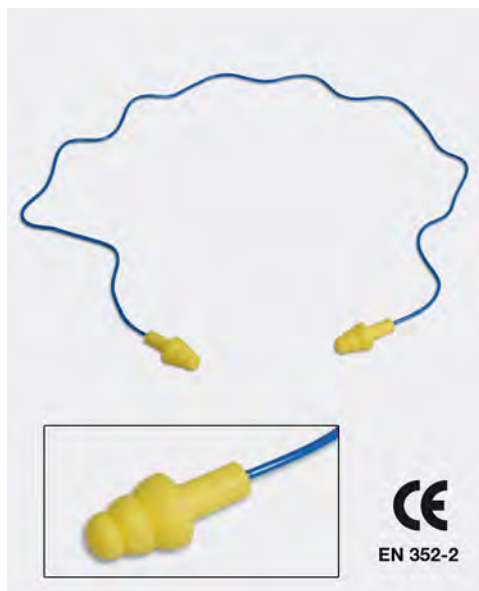

- Reusable earplugs.
- Use sectors: carpentry, joinery, construction, general industry, road making and construction, etc ..
- Flanges and smooth surface structure which increases the hygiene and comfort.
- Anatomically shaped self-modeling.
- Recommended for prolonged use.
- Earphones connected with cord that allows you to keep them hanging around his neck.
- Easy insertion cone-shaped caps. One size.

Code	Desc.
4460027435	31124

TABELLA DI ATTENUAZIONE

SNR 32 dB	H = 33 dB	M = 28 dB	L = 25 dB
-----------	-----------	-----------	-----------

## Earplugs with headband 26 dB



- Earplugs on lightweight headband.
- Articles designed to be comfortably worn even for the whole day.
- Foam sleeves ipoallergica that mold easily to all ducts earphones.
- Binaural special material, arranged to adapt to the movements of the head and jaw.
- It Can 'be brought both under the chin, that above his head.

Code	Desc.	Model
4460007450	4022	INSERTS-PHONES WITH BOW
4460007460	4023	TORQUE TRIM PARTS FOR ARCH

TABELLA DI ATTENUAZIONE

SNR = 26 dB	H = 30 dB	M = 22dB	L = 19dB				
FREQUENZA IN Hz	125	250	500	1000	2000	4000	8000
ATTENUAZIONE MEDIA (Mf) IN dB	22.5	21.5	19.0	22.6	30.3	35.7	38.8
DEVIAZIONE STANDARD (Sf) IN dB	3.5	3.6	2.9	2.7	3.1	4.2	4.3
PROTEZIONE PRESUNTA (APVf) IN dB	19.0	17.9	16.1	19.9	27.2	31.5	34.5

## Dust mask



- Disposable dust masks suitable for working with low toxicity.
- Shown against the irritating effects of non-toxic dusts as normal dust, pollen, etc..
- Unalterable in humid conditions.
- It does not irritate the skin, it is light and does not stop talking.

Code	Desc.
4460000900	2621

**N.B.: QUESTA MASCHERA NON È UN RESPIRATORE. DA NON USARSI PER VERNICI A SPRUZZO, AMIANTO, SABBIAIATURE, FUMI E GAS. NON INDICATA ALTRESI' PER POLVERI DI SILICIO E PESTICIDI.**

## Facemask folding FFP1 D



- FFP1 Protection D.
- Particularly suitable for the industry: bodywork, industry of wood, glass, cement, construction, mechanical, steel, chemicals, textiles and mining.
- Suitable for use in the presence of: iron, rust, concrete, stone, fillers.
- Protection from solid aerosols or liquids without specific toxicity at concentrations up to 4 x TLV.
- The particular form Allows to wear corrective eyewear that is protective.
- Rubber bands are stopped wing outside the edge of the skirt for added grip.
- Soft seal gasket in correspondence of the support of the nose.
- In accordance with EN 149: 2001 + A1: 2009.
- The masks are individually wrapped.

Code	Desc.	Characteristics
4460030490	32075	FFP1 MASK WITH VALVE INTAKE

## Facemask folding low toxicity FFP2 D



- FFP2 Protection D.
- Intended Use: body, pharmaceutical, chemical, metallurgy, shipbuilding, marine, agriculture and laboratories.
- Suitable for use in the presence of: wood, steel, concrete, spray paints, paints, antirust, fiber glass and mineral fibers, welding fumes, zinc, pesticides in aqueous solution, flours, molds, and spores, bacteria, soot .
- Protection from solid aerosols or liquids without specific toxicity or low toxicity in concentrations up to 12 x TLV.
- The particular form Allows to wear corrective eyewear that is protective.
- Rubber bands are stopped wing outside the edge of the skirt for added grip.
- Soft seal gasket in correspondence of the support of the nose.
- In accordance with EN 149: 2001 + A1: 2009
- The masks are individually wrapped.

Code	Desc.	Characteristics
4460030495	32080	MASK FFP2 WITH VALVE INTAKE



## Facemask folding high toxicity FFP3 D



- FFP3 Protection D.
- Intended Use: body, pharmaceutical, chemical, metallurgy, shipbuilding, marine, laboratory and field ecology.
- Suitable for use in the presence of: stainless steel, anti-fouling paints, asbestos, tuberculosis bacteria.
- Protection from solid aerosols or liquids without specific toxicity, low toxicity 'high toxicity' in concentrations up to 50 x TLV.
- The particular form Allows to wear corrective eyewear that is protective.
- Rubber bands are stopped wing outside the edge of the skirt for added grip.
- Soft seal gasket in correspondence of the support of the nose.
- In accordance with EN 149: 2001 + A1: 2009
- The masks are individually wrapped.

Code	Desc.	Characteristics
4460030500	32085	FFP3 MASK WITH VALVE INTAKE

## Face mask for harmful dust FFP1 (S)

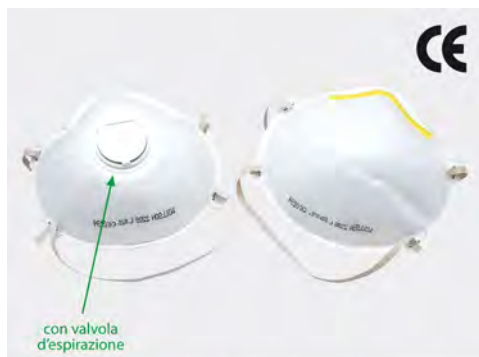

- Protection FFP1 (S).
- Industry use: Body, wood industry, glass, cement, construction, mechanical, steel, chemicals, textiles and mining.
- Harmful dust protection: protection from dust, fibers, aqueous mists of particulate material with a particle size > 0.02 microns. Mechanical and electrostatic filtration. Filtering efficiency > 78%.
- Other features: The special shape allows you to wear corrective eyewear that is protective.
- Rubber bands are stopped wing outside the edge of the skirt for added grip.
- Seal at the support of the nose.
- Limit use: 4.5 x TLV. (filters up to 4.5 times the level of human endurance). A EN 149 EC.
- **Complies with EN 149:2001+A:2009**

Dopo averla indossata modellare la zona del naso sul viso, premendo sullo stringinaso lungo i due lati.



Code	Desc.	Characteristics
4460009900	4330	MASK FFP1 (S) without exhalation valve
4460009910	4331	MASK FFP1 (S) with exhalation valve

## Activated carbon mask FFP1 (S)



Dopo averla indossata modellare la zona del naso sul viso, premendo sullo stringinaso lungo i due lati.

- Protection FFP1 (S).
- Industry use: body, chemical, pharmaceutical, laboratory, field ecology and shipbuilding.
- Specific mask for organic vapors and odors: The special layer of activated carbon can retain unpleasant odors caused by organic gases and vapors for concentration below its TLV.
- Other features: Soft seal at the nose.
- Adjustable nose clip.
- The elastic bands provide even tension.
- Limitation to use: Vapors <TLV; Dust 4.5 xTLV.
- **Complies with EN 149: 2001 + A: 2009**

Code	Desc.	Characteristics
4460009940	4335	MASK FFP1 (S) with exhalation valve

## Face mask for dust and fumes of low toxicity FFP2 (S)



Dopo averla indossata modellare la zona del naso sul viso, premendo sullo stringinaso lungo i due lati.

- Protection FFP2 (S).
- Industry use: Body, pharmaceutical, chemical, metallurgy, shipbuilding, agriculture and laboratories.
- Harmful dust protection: protection from dust, fibers, aqueous mists of particulate material with a particle size > 0.02 microns. Mechanical and electrostatic filtration. Filtering efficiency > 92%.
- Other features: The special shape allows you to wear corrective eyewear that is protective.
- Rubber bands are stopped by external fins on the edge of the face to ensure greater adherence.
- Seal at the support of the nose.
- Limit use: 12 x TLV. (filters up to 12 times the level of human endurance).
- Complies with EN 149: 2001 + A: 2009

Code	Desc.	Characteristics
4460009930	4333	MASK FFP2 (S) with the intake valve
4460027440	31125	MASK FFP2 (S) without intake valve

## Face mask for dust and toxic fumes FFP3 (S)



Dopo averla indossata modellare la zona del naso sul viso, premendo sullo stringinaso lungo i due lati.

- FFP3 protection (S).
- Intended Use: Body, chemical, pharmaceutical, laboratory, field ecology and shipbuilding.
- Features: harmful dust, fibers and aerosols based organic particulate material with a particle size > 0.02 microns. Mechanical and electrostatic filtration. Filtering efficiency 98%.
- Other features: Soft seal at the nose.
- Adjustable nose clip.
- The elastic bands provide even tension.
- Limitation to use: Vapors <TLV; Powder 50 xTLV.
- Complies with EN 149: 2001 + A: 2009

Code	Desc.	Characteristics
4460009935	4434	MASK FFP 3 (S) with exhalation valve

### Half mask with filters FFA1P1



- Disposable half mask complete with filters to CE EN 405:2001.
- Use sectors: paint jobs, body.
- Benefits: Lightweight ergonomic, comfortable.
- Double filter for maximum protection.
- Possibility 'to adapt to the operator's face thanks to the adjustable edge.
- Filter type FFA1P1, organic vapor, harmful dust and spray painting, solvents etc.

Code	Desc.
4460007600	4030

### Filtering half masks to fume and dust FFA1P2 RD



- Facemask filter ready for use and extremely comfortable.
- Intended Use: body, pharmaceutical, chemical, metallurgy, shipbuilding, marine, agriculture.
- Usable for different types of applications: spray painting, use of organic diluents or materials containing solvents, production of paints, varnishes, resins, inks and dyes, insecticides, herbicides and pesticides.
- Maintenance-free, non-latex particles are natural.
- From the ergonomic profile, provides the operator with maximum visibility to work in optimal conditions.
- Protection class FFA1P2 R D.
- Maximum usage level: gases and vapors in concentrations up to 1000 ppm or 10 times the Threshold Limit Value (TLV).
- According to EN 405: 2001 + A1: 2009.

Code	Desc.
4460030510	32095

## Semimaschera facciale



- Half-face mask of soft silicone rubber, with replaceable filters.
- Use sectors: paint jobs, body, waste disposal, industrial work, handling chemicals, plastics processing, etc.
- Advantages: lightweight, ergonomic, comfortable.
- With double filter and exhalation valve. Filter with bayonet. Wide range of filter types for all kinds of work carried out.
- Possibility 'to suit the operator's face thanks to the adjustable edge.
- Supplied without filters.

Code	Desc.
4460007500	4024

### FILTRI DI RICAMBIO (compatibili solo con prodotti Honeywell)

CODICE	DESCR.	TIPO FILTRO	CARATTERISTICA
446 00 07510	4025/1	A2P3	Filtro combinato per gas e vapori organici, polveri tossiche. Classe 2 (per concentrazioni di gas e vapori fino a 5000 ppm).
446 00 07530	4025/3	K2	Filtro per ammoniaca e derivati, classe 2 (per concentrazioni di gas e vapori fino a 5000 ppm)
446 00 07540	4025/4	A1B1E1K1	Filtro combinato per gas e vapori organici, acidi, ammoniaca e derivati. Classe 1( per concentrazioni di gas e vapori fino a 1000 ppm)
446 00 07550	4025/5	P3	Filtro per polveri tossiche e fumi
446 00 07580	4025/6	A1B1E1K1P3	Filtro combinato, per gas e vapori organici, inorganici, acidi, ammoniaca e derivati, polveri tossiche. Classe 1( per concentrazioni di gas e vapori fino a 1000 ppm)

## Knee polyurethane



- Pair of knee pads in polyurethane foam.
- Intended Use: installers, electricians, thermo-hydraulic, tilers, mechanics, body shops, wherever they have needs' to work on his knees for a long time.
- Benefits: the ergonomic and comfortable fit for any type of knee ensuring maximum comfort of use.
- Waterproof. setting around the knee with fixing tape. easy to clean.
- Built in keeping with the legislation 89/686 / EWG7II, I 4ff.

Code	Desc.
4460027445	31126



## Protective glasses



- Protective glasses with single polycarbonate lens anti-scratch and anti-fog.
- Lightweight only 23 grams, and wrap-around shape.
- Nose pads with soft rubber grip.
- Used in various industries including: carpenters, blacksmiths, fabricators, installers, maintenance personnel, building, body shops, mechanical industries, etc.
- Providing protection from grinding, turning, assembly, assembly, drilling, sanding, etc.
- Lens choice between the following colors: transparent, yellow and gray.
- According to EN 166 generic protection, according to EN 170 UV filters

Code	Desc.	Lens Color	Application
4460027450	31127T	Transparent (1)	Closed environments
4460027455	31127A	Yellow (2)	Environments with low light, laser pointers.
4460027460	31127G	Grey (3)	External use against the glare of the sun.

## Mirrored safety glasses



- Safety glasses with single lens mirrored silver polycarbonate scratch and fog.
- Lightweight only 27 grams. wraparound design of the lens that offers excellent side protection.
- Used in various industries including: carpenters, blacksmiths, fabricators, installers, maintenance personnel, building, body shops, mechanical industries, etc.
- Suitable for operators working both internally and outside.
- Providing protection from grinding, turning, assembly, assembly, drilling, sanding, etc.
- According to EN 166 generic protection, according to EN 170 UV filters, in accordance with EN 172 sunscreens for industrial use.

Code	Desc.	Lens Color	Application
4460009760	4314/S	Mirror	for use both internally and externally against the glare of the sun

## Protection Safety glasses with earpiece



- Safety glasses with side shields.
- Intended Use: carpenters, blacksmiths, fabricators, maccanici, body shops, machine shops in general.
- Advantages: practical and lightweight rods fixed.
- Glasses sold with clear lens
- Available as replacement lenses convex mineral glass transparent color and green DIN 5.
- With central screw for fast and easy replacement of the lens.
- In accordance with EN 166.

Code	Desc.	Characteristics	Compliance
4460009025	4229	Glasses	EN 169
4460009030	4230	Clear Lens	EN166 protects the operator from high speed particles' and low impact energy.
4460009033	4230-V	Lenses for welding	EN 175 protects the operator from the particles at high speed 'and low impact energy.

## Protective glasses with adjustable rods



- Protection eyewear with a modern, very comfortable.
- Intended Use: carpenters, blacksmiths, fabricators, installers, maintenance personnel, machine shops in general.
- Benefits: modern line and enveloping. Lightweight frame, only 36 gr. Rods adjustable in length and inclination to adapt to all faces.
- Lens-piece scratchproof, colorless.
- In accordance with EN 166 DPI CAT. II.

Code	Desc.
4460027470	31128

## Occhiali di Protezione Meccanocar Premium



- Occhiale di protezione dal design accattivante con lente trasparente e trattamento antigraffio plus, che assicura la massima resistenza all'abrasione.
- Certificato secondo la normativa EN166 antigraffio certificato K
- Gli occhiali di protezione Premium Meccanocar sono studiati con un'esclusiva tecnologia che permette la massima adattabilità al viso dell'utilizzatore migliorando la stabilità.
- Sistema di ventilazione integrato che consente il naturale flusso d'aria.
- Le lenti, in classe ottica 1 , permettono di ottenere prestazioni migliori senza affaticare la vista durante l'impiego quotidiano.
- Studiati per ottenere il massimo comfort per l'operatore, la struttura e i materiali utilizzati permettono di ammortizzare al massimo i punti di contatto dell'occhiale al viso.
- <Massima leggerezza del prodotto: solo31 gr

Code	Description
4460000540	5X3M

## Protection Safety glasses with mask



- Safety glasses for various processes.
- Lens treated durafon unbreakable.
- Misters.
- Adjustable elastic.
- Frame and lens colorless.
- A CE EN 166.
- Indirect ventilation.
- Optical class 1.

Code	Desc.
4460008000	4036

## Mask Protective glasses



- Protective glasses for various applications.
- Direct ventilation.
- Clear Lens optical class 1.
- Adjustable elastic.
- In accordance with CE EN 166.

Code	Desc.
4460009480	4298

## Warning tape industrial boundaries for various-reflective and fluorescent



- For various signals, such as areas of construction sites, delimited paths within industrial, boundaries of areas depending on the safety regulations, reports protruding objects etc ...
- With to the right and to the left.
- Tape length 11.5 m and h. 50 mm.

Code	Desc.	Characteristics
4460000105	7121/R/DX	red / white right-refracting
4460000110	7121/R/SX	red / white left-refracting
4460000120	7122/R/DX	yellow / black- right-refracting
4460000125	7122/R/SX	yellow / black- left-refracting
4460000130	7118/R	fluorescent red
4460000135	7118G	yellow-fluorescent

## PVC column h 90 cm



- Colonnina in PVC bianca e rossa ø 4 cm.
- Base appesantita in cemento cm 29x29.
- In abbinamento con la catena PVC n/s cod. 446 00 04200 3977 è velocemente possibile creare una barriera segnaletica.
- Idonea per ambienti interni ed esterni.
- Utilizzata da: stazioni di servizio, concessionarie, autosaloni ecc..

Code	Desc.
4460004400	3979

## Chain PVC white / red



- PVC chain white and red.
- To use as a barrier signs.

Code	Desc.	Length mt
4460004200	3977	25



### PVC cone h 30 cm



- Red / white.
- To be used as a delimitation and median.

Code	Desc.	Characteristics
4460002550	3961/30	CONE PVC H30 cm

### PVC cone h 50cm



- Red / white.
- To be used as a delimitation and median.

Code	Desc.	Characteristics
4460002600	3961/50	CONE PVC H50 cm

### Tape bounding



- Warning tape bounding white / red sided.
- Made of polyethylene.

Code	Desc.	Measures
4460000100	2000	H70mmx200m

## Safety harness



- Safety harness in polyester and polyamide with two anchorage points: dorsal ring with "D", and sternal with slots in the fabric.
- The 2 front webbing loops are mandatory joint with a carabiner, to which you must connect a fall arrest (eg our cod. 4460009036).
- Shoulders, chest and adjustable leg. one size.
- CE compliant to EN 361.
- Suitable for work on scaffolding, scaffolding, roofs.
- Intended Use: plant engineering, construction, builders, maintainers, editors.
- Complete instructions inside the package.

Code	Desc.
4460027550	31135

## Full body harness with positioning belt



- Safety harness in polyester and polyamide with positioning belt and two anchor points: dorsal ring with "D", and sternal with slots in the fabric.
- The 2 front webbing loops are mandatory joint with a carabiner, to which you must connect a fall arrest (eg our cod. 4460009036)
- Shoulders, chest and adjustable leg. one size.
- CE compliant to EN 361 - EN 358.
- Suitable for work on scaffolding, scaffolding, roofs.
- Intended Use: plant engineering, construction, builders, maintainers and editors.
- Complete instructions inside the package.

Code	Desc.
4460027555	31136

## Positioning Belt



- Positioning belt in polyester and polyamide. frontal attack 2 rings "D" in galvanized steel.
- Adjustable waist. One size.
- Complies with CE EN 358.
- Positioning belt padded for increased comfort. Along with the positioning lanyard Code 446 00 09045 and not 'a fall arrest system.
- Complete instructions inside the package.

Code	Desc.
4460009040	4232

## Positioning lanyard with carabiner



- Positioning lanyard in polyamide, with light alloy carabiner closing.
- Complies with CE EN 358.
- To be used together with positioning belt Code 446 00 09040. Along with positioning belt is not 'a fall arrest system.
- Complete instructions inside the package.

Code	Desc.
4460009045	4233

## Carabiners



- Carabiner steel (picture 1) with manual locking screw.
- Carabiner light alloy (photo 2) with automatic lock that prevents accidental opening.
- EU standard EN 362.

Code	Desc.	Article	Photo
4460027560	31137	KARABINER STEEL	1
4460027565	31138	KARABINER LIGHT ALLOY	2

## Aluminum hook



- Aluminum hook with 60mm opening.
- Opening with double security, which prevents accidental opening.
- Ideal for work on scaffolding and pylons.
- Opening with only one hand. Automatic closing.
- Complies with CE EN 362.

Code	Desc.
4460027570	31139

## Energy absorber with lanyard hook



- Lanyard with energy absorber, supplied with hook 60mm opening and snap.
- If dropped absorbs the tear on the body, allowing a smooth stop and without repercussions.
- Use with other fall protection systems, for working on floors above ground, roofing, roofs, yards.
- Tape length 2 mt.
- So that 'the device features the minimum space between the operator and the point of impact, if any must be at least 6 meters.
- Complies with CE EN 355.
- Complete instructions inside the package.

Code	Desc.
4460027575	31140

## Dispositivo anticaduta retrattile da 10 mt



- Dispositivo anticaduta retrattile in materiale antiurto abs.
- Indicato per lavori in verticale o inclinati massimo 40° su ponteggi, coperture, piani rialzati da terra e cantieri.
- Fornito di cavo retrattile d'acciaio galvanizzato da 10 mt e moschettone girevole. il moschettone e' inoltre dotato di rilevatore di caduta (foto 1).
- La sua funzione e' quella di assorbire l'energia cinetica acquisita dall'utilizzatore nel corso di una caduta.
- Il meccanismo situato all'interno del dispositivo entra in azione immediatamente e blocca progressivamente la caduta dell'operatore rallentando dolcemente la sua velocita'.
- Il dispositivo si collega direttamente all'imbracatura e permette all'operatore di muoversi liberamente.
- Peso massimo ammissibile fino a 130 kg.
- Conforme alla normativa ce en 360.

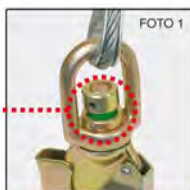

L'ANELLO VERDE INDICA CHE IL DISPOSITIVO NON HA ASSORBITO CADUTE

Code	Desc.	Lunghezza cavo mt	Ø cavo mm	Weight Kg.
4460030570	32155	10	4,5	6,25



## Winder fall arrester



- Security system consisting of polyamide webbing retractor equipped to allow the free movement of the operator up to a maximum distance of 2.25 mt linear. It equipped with sink energy, which when dropped absorbs the tear on the body allowing a fall arrest sweet and without repercussions.
- Can be used by anyone who has to work on floors above ground, roofing, roofs, yards, wherever there is the need to be free to move with the assurance of effective protection in the event of a fall.
- To be used always coupled with positioning belt and the safety harness.
- The belt retractor is provided with two hooks, one to place it in a fixed point sealing with a minimum of 10 KN, and the other by positioning the sealing ring on the back of the harness. Maximum weight 150 kg user. The minimum space required under the operator because the device exerts its function is 5 mt.
- Complies with standards EN 360: 2003. Classified as PPE under the European directive 89/686 / EEC.

Code	Description
4460009036	Winder fall arrester

## Temporary lifeline

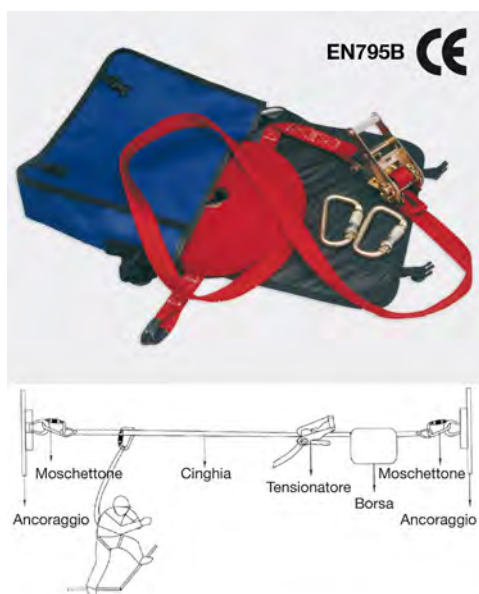

- Fall arrester temporary lifeline length 20 meters. Polyester belt width of 30 mm.
- Supplied in a practical bag with two safety carabiners and with a Strap-tensioner.
- Indicated for the horizontal displacement of roofs, for the assembly and dismantling of scaffolding, etc.
- Intended Use: plant engineering, construction, builders, maintainers and editors.
- It can support up to two operators. If dropped supports the operator, not by sliding into the void.
- CE compliant to EN 795B.
- Complete instructions inside the package.

Code	Desc.
4460027585	31142

## Protective suit disposable white



- Body protection white polypropylene coated with a microporous breathable film.
- Intended Use: painting, repair shops, body shops, construction, carpentry, agriculture, waste and asbestos, pharmaceutical, food.
- Piece suit complete with hood with elastic around the face, elastic stringipolso, stringicaviglia and constriction.
- Zipper closure.
- It protects the user from direct contact with chemical agents due to exposure to light sprays and solid particles dispersed in the air.
- Hydrophobic, does not absorb any liquid.
- With properties' anti-static.
- Lightweight and comfortable, resistant to tearing and abrasion. It does not leave lint.
- The suit must be replaced at the end of its use being disposable.
- In accordance with CE CAT. III

Code	Desc.	Taglia
4460030860	32270	M
4460030865	32270	L
4460030870	32270	XL
4460030875	32270	XXL

## Coverall Tyvek®



- Body protection Tyvek® white - laced - with zippers, elastic wrists and ankles - breathable, allowing the elimination of the water vapor produced by the body.
- Water repellent, not impolpa any liquid.
- It protects during the steps of coating, sealing with underbody and polyurethane, from alkaline and acid solutions and lubricants.
- Does not fray, and 'light and comfortable - is resistant to tearing and abrasion - A CE cat. III.

Code	Desc.	Taglia
4460007350	4016-M	M
4460007360	4016-L	L
4460007370	4016-XL	XL
4460007380	4016-XXL	XXL

## White suit polypropylene



- Polypropylene material.
- White color.
- Complete with hood, rear pocket.
- Application of elastic hood, wrists, waist and ankles.
- Available Sizes: M-L-XL-XXL.
- A CE.
- Pack per carton nr. 25 pcs.
- Identified as disposable suits.

Code	Description	Taglia
4460211940	White suit size M	M
4460211945	White suit size L	L
4460211950	White suit size XL	XL
4460211955	White suit size XXL	XXL

## Protective apron, PVC



- PVC apron tear.
- Dimensions: 75x100 cm.
- With laces.
- White color.

Code	Desc.	Measure
4720007500	186	75 x 100

## Rubber insulating mat: insulation to 26,500 Volts AC



- Dielectric insulating mat for working at high voltages up to 26,500 Volts AC. Manufactured in slip-proof rubber with printed material surfaces.
- Indicated for use by electrical installers, electricians, building sector, transport sector, mechanics and mechatronic technicians for working on electric and hybrid cars, etc.
- Flexible and stable, 3 mm thick, does not propagate flames in accordance with IEC 61111. Test mark marked on every metre of mat.
- Supplied in 1 m wide rolls with a length of 2 m

Code	Desc.	IEC 61111	Tensione di prova	Tensione di tenuta	Tensione di utilizzo	Spessore
4460042280	32377	Class 3	30 KV	40 Kvac	26,5 Kvac	3 mm

## Guanti in lattice isolanti “dielettrici”



- Guanti in lattice naturale specifici per lavori sotto alte tensioni, disponibili in cinque classi diverse a seconda dell'isolamento richiesto.
- Specifici per lavorazioni che prevedono il contatto diretto con cavi che trasportano elevate tensioni.
- Ogni paio di guanti viene fornito all'interno di una confezione richiudibile, in cui devono essere conservati fra un uso e l'altro, ed accompagnati da istruzioni specifiche per l'uso e l'eventuale pulizia e controlli periodici.
- Superfici interna ed esterna lisce, lunghezza dei guanti 36 centimetri, interno talcato. Taglia unica.
- **\* Proprietà speciali:**
  - A: resistente agli acidi
  - H: resistente agli oli
  - Z: resistente all'ozono
  - R: resistente agli acidi, agli oli e all'ozono
  - C: resistente a temperature molto basse

Code	Desc.	Voltage max. of use	Tensione di prova	Classe	Proprietà speciali*	Thickness mm
4460000610	7111/00	500 V	2500 V	00	AZC	0,5
4460000620	7111/0	1000 V	5000 V	0	RC	1,0
4460000630	7111/1	7500 V	10000 V	1	AZC	1,5
4460000640	7111/2	17000 V	20000 V	2	RC	2,3
4460000650	7111/3	26500 V	30000 V	3	RC	2,9

## Dielectric insulating boots 20,000 Volts



- Specific insulating boots for working at high voltages; tested and certified to 20,000 Volts AC, equipped with antiperforation soles in composite material and integral steel toe cap with resistance up to 200 Joules.
- Indicated for use by electrical installers, electricians, building sector, transport sector, mechanics and mechatronic technicians for working on electric and hybrid cars, etc.
- Antislip sole equipped with crampons for stairways, internal rotproof material.
- Responding to the norms: EN ISO 20345:2007 SBPE, CI, SRC; EDF HTA 70B specification. PPE durable: 5 years from the date of production printed on the sole. Supplied with detailed user and maintenance manual

Code	Description	Taglia
5170004200	37-38/nsulating boots	37-38
5170004210	40-41/Stivali isolanti	40-41
5170004220	43-44/Stivali isolanti	43-44
5170004230	46-47/Stivali isolanti	46-47



## Provisions on the company first aid

- Published in the Official Gazette 101 of 30 April 2008 entered into force on 81 DGLS of 9 April 2008. The Decree lays down the provisions for first aid in the workplace and, as regards the allocation of materials for first aid in the company, with the art. 45 is riconfermata the validity of the Ministerial Decree 388 of 15 July 2003. In order to identify the cassette suitable for every type of business need to follow the following classification:
- Group A
  - Companies or production units with industrial activity, thermal power plants, nuclear plants and laboratories, companies and other mining and quarrying, underground work, companies for the manufacture of explosives, gunpowder and munitions.
  - Companies or establishments with more than five workers belonging or related to the tariff groups with INAIL injury rate of permanent disability than four.
  - Companies or establishments with more than five permanent workers of the sector of agriculture.
- Group B
  - Companies or production units with three or more workers who do not fall into Group A.
- Group C
  - Companies or production units with less than three workers who do not fall in the group A.

## First aid kits for all companies



- Metal cabinet with 3 compartments, 2 shelves.
- Lock and key.
- Recommended for companies which are in group A and B.
- Dimensions 460x300x140mm.
- Weight: 7.50 kg.
- CONTENT:
  - 1 min Copy Decree 388 of 07/15/03
  - 5 Pairs of sterile gloves
  - 1 mask with eye protection visor
  - 3 Sterile saline solutions 500 ml CE
  - 2 bottles 500 ml disinfectant IODOPOVIDONE 10% iodine PMC
  - 10 Envelopes compressed sterile gauze 10x10 cm
  - 2 Envelopes compressed sterile gauze 18x40 cm
  - 2 Sterile drapes cm 40x60 DIN 13152-BR
  - 2 Sterile forceps
  - 1 pack of cotton wool
  - 1 Case tubular elastic bandage
  - 2 10 assorted dressings
  - 2 Spools adhesive plaster m 5x2.5 cm
  - 1 pair scissors tagliabendaggi 14.5 cm DIN 58279
  - 3 Tourniquets
  - 2 ICE PACK Disposable instant ice
  - 2 bags for medical waste
  - 1 Medical digital thermometers
  - 1 personal sphygmomanometer with stethoscope
  - 1 Operating MULTILANGUAGE pronto rescue.
- **\* Replacement kit usable also for the reinstatement of the cabinet of product aid for all companies (same content to the left indicated).**

Code	Desc.
4460007915	4035/1
4460009608	4308/3 KIT*

## First aid kit over 3 people



Code	Desc.
4460009611	4309/1
4460009608	4308/3 KIT*

- Activity 'over 3 people.
- Case in abs with support for wall mounting.
- Recommended for companies which are in group A and B.
- Dimensions 395x270x135 mm.
- Weight. 6.20.
- CONTENT:
- 1 Copy of ministerial decree 388 of 07/15/03
- 5 Pairs of sterile gloves
- 1 mask with eye protection visor
- 3 Sterile saline solutions 500 ml CE
- 2 bottles disinfectant 500 ml to IODOPOVIDONE
- 10% iodine PMC
- 10 Envelopes compressed sterile gauze 10x10 cm
- 2 Envelopes compressed sterile gauze 18x40 cm
- 2 Sterile drapes 40 cm x 60 DIN 13152-BR
- 2 Sterile forceps
- 1 pack of cotton wool
- 1 Case tubular elastic bandage
- 2 10 assorted dressings
- 2 Spools adhesive plaster m 5 x 2,5 cm
- 1 pair of scissors tagliabendaggi 14.5 cm DIN 58279
- 3 Tourniquets
- 2 ICE PACK instant ice
- 2 bags for medical waste minigrip
- 1 Clinical thermometer with case EC
- 1 sphygmomanometer PERSONAL
- 1 Operating MULTILANGUAGE p. rescue
- \* Complete kit parts can also be used to replenish the deposit for more than 3 people (same content indicated above).

## First aid kit up to 2 people



Code	Desc.
4460009606	4308/1
4460009607	4308/2 KIT*

- Activity 'up to 2 people.
- ABS case with support for wall mounting and carrying handle.
- Recommended for companies which are in group C.
- Dimensions 250x190x90 mm.
- Weight. 1.40.
- CONTENT:
- 1 Copy of ministerial decree 388 of 07/15/03
- 2 Pairs of sterile gloves
- 1 bottle disinfectant 125 ml
- IODOPOVIDONE 10% iodine PMC
- 1 Sterile saline solutions 250 ml CE
- 1 Envelope compressed sterile gauze 18x40 cm
- 3 Envelopes compressed sterile gauze 10x10 cm
- 1 sterile pliers
- 1 pack of cotton wool
- 1 10 assorted dressings
- 1 Spool adhesive plaster m 5x2.5 cm
- 1 gauze bandage m 3,5x10 cm
- 1 pair of scissors tagliabendaggi 14.5 cm DIN 58279
- 1 Tourniquet Latex free
- 1 ICE PACK Disposable instant ice
- 1 bag for medical waste 250x350 mm
- 1 Operating MULTILANGUAGE emergency
- \* Complete kit parts can also be used to replenish the tape up to 2 people (same content as described above).

## Kit remove splinters in case



- Useful to extract splinters of various kinds and for a first dressing of the injured party.
- The pencil remove splinters and 'equipped with a magnetic tip neodymium which allows for the removal of ferrous splinters avoiding dangerously approach the tip to the eyeball, the other tip of the pencil and' includes a slot nylon for the removal of Nonferrous splinters.
- Dimensions: 235x190x43 mm.
- Weight: 0.5 kg.
- CONTENT:
- 1 pencil remove shrapnel professional, 1 magnifying glass, 1 mirror, 1 bottle of 100 ml with sterile saline eye cap, 1 pliers remove splinters steel 115 cm, 2 envelopes sterile gauze 18x40 cm.

Code	Desc.
4460008040	4039

## Kit Eye wash emergency



- Kit for emergency eye wash consists of 2 bottles of saline sterile disposable 500 ml with cap eyepiece mounted for quick use.
- Product indicated for all work activities where the operators can be in contact with splinters, dust or subjected to possible accidents to the eyeball for which the need exists for a quick intervention.
- The anatomical shape of the cap allows you to place it directly on the eyeball preventing any contact between the eye and the hand.
- Support is thermoformed material with transparent cover and dust with mirror.
- It can be applied to the wall of any local working, provided with screws and dowels.
- Dimensions: 32x41x7,5 cm.
- Ideal for all workplaces, especially shops, body shops, carpentry and wherever they want to avoid problems related to waste processing.
- It can be used in marine or by hauliers as a briefcase to hold on means.
- CONTENT:
  - 2 vials of sterile saline 500 ml
  - 2 integrated eye showers
  - 1 mirror.
- HOW TO USE:
  - To open the package to pull the cover slightly, letting it fall down. Pull out the bottle, turn the cap breaking the seal and apply on the affected part. The anatomic cork allows you to direct precisely the jet, obtaining an efficient eye wash without waste.
  - The mirror mounted in the station can be a useful accessory to make a first assessment of any injuries.
- Kit
- Saline 500ml parts

Code	Desc.	Characteristics
4460027900	31340	Kit
4460027905	31345	Soluzione salina da 500ml di ricambio



## Empty first aid case



- Empty case for first aid kit, complete with wall bracket, carry handle, and double fastening clip.
- Sturdy, shockproof, and made in polypropylene. Two movable dividers. Measurements: 320 x 230 x 90 mm

Code	Desc.
4460001190	3946.9

## Self-adhesive elastic dressing

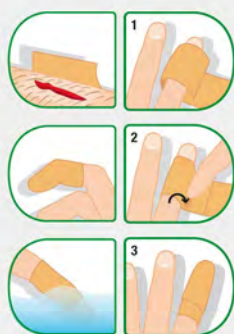

- Practical elastic dressing utilizable as a first-aid plaster.
- The self-adhesive dressing is a practical dressing that can be cut into large pieces of the correct dimension of product to suitably cover the injured parts to protect.
- The dressing is self-adhesive that permits easy application without sticking to the injury or the body hair
- The product is particularly absorbent and resistant to water. A fast, practical, effective system to protect injuries. Can be used as a replacement for the medical cabinet or the first-aid box (4460007915 – 4460009606 – 4460009611)

Code	Measure cm	Color
4460009609	6x100 cm	Skin



## Cerotti assortiti



- Assortimento di 10 cerotti di varie dimensioni: n° 2 pezzi 6x2 cm, n° 2 pezzi 7x2 cm, n° 3 pezzi 4x1 cm, n° 3 pezzi diametro 2 cm.
- A norma CE 93/42.

Code	Desc.
4460009604	4704/4

## Ghiaccio istantaneo



- Ghiaccio istantaneo in busta, pronto all'uso, per piccoli traumi ed emorragie. Mantiene fredda la parte lesa per circa 15 minuti dopo l'attivazione.
- A norma CE 93/42. Dimensioni: 15x18 cm, peso 250 g.

Code	Desc.
4460009601	4307/1

## Soluzione fisiologica salina sterile



- Flaconi monouso di soluzione fisiologica salina sterile, contenente lo 0,9% di cloruro di sodio. Indicata per il lavaggio di ferite ed escoriazioni, lavaggi oculari, irrigazioni e pulizie del cavo orale.
- Prodotto conforme alla direttiva 93/42/EEC, Annex II, sezione 3.2 - Marchio CE 0123 - classe di appartenenza: IIa

Code	Desc.	Cont. ml
4460001040	3945.4	500
4460009603	4307/3	250

## “Iodopovidone” antiseptic, antibacteria



- Antiseptic, antibacterial solution (diluted to 10%), ideal for the disinfection of hard surfaces: preparation in working area, disinfection of the skin before injection, antiseptic and microbicide for doctor's surgeries.

Code	Desc.	Content
4460001030	3945.3	500 ml
4460009602	4307/2	125 ml

## Cotton wool



- Ultra-fine cotton wool to cleanse and bandage wounds. Conforms to EC 93/42 standard.

Code	Desc.	Content
4460001120	3946.2	20 g

## Adhesive dressing roll



- Adhesive dressing roll. Ideal for securing dressings to be maintained for any length of time.
- 5-metre roll. 2.5 cm high. Compliant with EC 93/42 standard.

Code	Desc.	Dimensions
4460001130	3946.3	2,5 cm x 5 m

## Hemmed gauze bandage



- 100% cotton wool hemmed gauze bandage. Not sterile. Packed individually in cellophane and polyethylene bag.
- Class I medical device, 93/42/EEC, conforming with current Official Pharmacopoeia. Free from barium thread.

Code	Desc.	Dimensions
4460001110	3946.1	10 cm x 3,5 m

## Sterile cotton gauze compresses



- Disposable sterile compresses in cotton gauze. Free from other fibres and barium thread. Precut and not folded. Intended use: compression and absorption of blood and exudates.
- Fabric count: 12/8. Yarn count: 32/40. Product sterilised with ethylene oxide, in conformity with the UNI EN 550 standard.

Code	Desc.	Dimensions
4460001050	3945.5	10 x 20 cm
4460001060	3945.6	18 x 40 cm

## Tubular elastic mesh



- Tubular elastic mesh to secure dressings on the limbs. Medium calibre: extends to up to 1 metre.
- Compliant with EC 93/42 standard.

Code	Desc.
4460001090	3945.10

## Flat tourniquet



- Flat, elastic tourniquet. Resistant and completely free from latex. Made in nitrile.
- Compliant with EC 93/42 standard.

Code	Desc.
4460001150	3946.5

## Ecological thermometer



- Oval ecological thermometer, made in glass for hygienic use and easy disinfection. Precise model with no need for calibration.
- Compliant with EC 93/42 standard. May be disposed of as normal household waste.

Code	Desc.
4460001160	3946.6

## Blood pressure monitor



- Blood pressure monitor with stethoscope. Pressure gauge with needle in light alloy, complete with adult-size armband in cotton with Velcro fastening. Integrated stethoscope to listen to the heartbeat.
- Measuring tolerance +/- 3 mm/Hg. Compliant with CE 93/42 and DL 24.2.97 standards. Supplied in faux leather case with zipper.

Code	Desc.
4460001170	3946.7



## Surgical mask with visor



- Disposable surgical mask in TNT. Three layers in green with splash protection visor. Worn with side elastics and complete with soft, modelling nose clips.
- Three layers of fabric for the maximum protection against external agents. Class I medical device, compliant with EC 93/42 directive.

Code	Desc.
4460001195	3946.10

## Disposable sterile tweezers



- Disposable sterile tweezers in polypropylene. Individually packed. Length 11 cm

Code	Desc.
4460001080	3945.8

## Steel bandage scissors



- Bandage scissors with steel blades and plastic handles. Rounded tips for injury protection.
- Lister model. 19 cm in length.

Code	Desc.
4460001140	3946.4

## Sterile sheet in non-woven fabric



- Absorbent sterile sheet in non-woven fabric. Individually packed and ideal for covering beds during examinations or patients during medication.
- Size: 40 x 60 cm

Code	Desc.
4460001070	3945.7

## Clear refuse bags



- Clear refuse bags specifically for hospital waste. Suitable for use in containers for special waste. Size 20 x 30 cm

Code	Desc.
4460001180	3946.8

## SAFETY SIGNS

- Safety signs built with size, color characteristics and colorimetric comply with the requirements of Directive 92/58 / EEC - UNI 7543 - ISO 3864, referred to by the D.Lgs.493 / 96 released in the new Legislative Decree 81/08 . Dimensional tolerances according to UNI EN 485-4.

### Obligation signs



- Signs must aluminum.
- To be exhibited on site or in workshops.
- Suitable for exterior and interior. Good solvent resistance.
- The pictogram visible on the sign is useful in working environments where there are foreign workers.

Code	Desc.	Spessore cartello mm	Formato mm	Max reading distance mt
4460026700	31510	0,7	333X500	10
4460026705	31515	0,7	166X210	6



- Aluminum obligation signs.
- To be exhibited on site or in workshops.
- Suitable for exterior and interior. Good solvent resistance.
- The pictogram visible on the sign is useful in working environments where there are foreign workers.

Code	Desc.	Spessore cartello mm	Formato mm	Max reading distance mt
4460026710	31520	0,7	333x500	10
4460026715	31525	0,7	166x210	6

11



- Aluminum obligation signs.
- To be exhibited on site or in workshops.
- Suitable for exterior and interior. Good solvent resistance.
- The pictogram visible on the sign is useful in working environments where there are foreign workers.

Code	Desc.	Spessore cartello mm	Formato mm	Max reading distance mt
4460026720	31530	0,7	333X500	10
4460026725	31535	0,7	166X210	6



- Aluminum obligation signs.
- To be exhibited on site or in workshops.
- Suitable for exterior and interior. Good solvent resistance.
- The pictogram visible on the sign is useful in working environments where there are foreign workers.

Code	Desc.	Spessore cartello mm	Formato mm	Max reading distance mt
4460026730	31540	0,7	333X500	10
4460026735	31545	0,5	270X370	10



- Aluminum obligation signs.
- To be exhibited on site or in workshops.
- Suitable for exterior and interior. Good solvent resistance.
- The pictogram visible on the sign is useful in working environments where there are foreign workers.

Code	Desc.	Spessore cartello mm	Formato mm	Max reading distance mt
4460026740	31550	0,7	333X500	10
4460026745	31555	0,7	166x210	6



- Aluminum obligation signs.
- To be exhibited on site or in workshops.
- Suitable for exterior and interior. Good solvent resistance.
- The pictogram visible on the sign is useful in working environments where there are foreign workers.

Code	Desc.	Spessore cartello mm	Formato mm	Max reading distance mt
4460026750	31560	0,7	333X500	10
4460026755	31565	0,7	166x210	10



- Aluminum obligation signs.
- To be exhibited on site or in workshops.
- Suitable for exterior and interior. Good solvent resistance.
- The pictogram visible on the sign is useful in working environments where there are foreign workers.

Code	Desc.	Spessore cartello mm	Formato mm	Max reading distance mt
4460026760	31570	0,7	333X500	10
4460026765	31575	0,7	270X330	10





- Aluminum obligation signs.
- To be exhibited on site or in workshops.
- Suitable for exterior and interior. Good solvent resistance.
- The pictogram visible on the sign is useful in working environments where there are foreign workers.

Code	Desc.	Spessore cartello mm	Formato mm	Max reading distance mt
4460026770	31580	0,7	333X500	10



- Aluminum obligation signs.
- To be exhibited on site or in workshops.
- Suitable for exterior and interior. Good solvent resistance.
- The pictogram visible on the sign is useful in working environments where there are foreign workers.

Code	Desc.	Spessore cartello mm	Formato mm	Max reading distance mt
4460026775	31585	0,7	270X330	10



- Aluminum obligation signs.
- To be exhibited on site or in workshops.
- Suitable for exterior and interior. Good solvent resistance.
- The pictogram visible on the sign is useful in working environments where there are foreign workers.

Code	Desc.	Spessore cartello mm	Formato mm	Max reading distance mt
4460026780	31590	0,7	270X330	10



- Aluminum obligation signs.
- To be exhibited on site or in workshops.
- Suitable for exterior and interior. Good solvent resistance.
- The pictogram visible on the sign is useful in working environments where there are foreign workers.
- Obligation ground symbol.

Code	Desc.	Spessore cartello mm	Formato mm	Max reading distance mt
4460026785	31595	0,7	115X115	4

## Prohibition Signs



- Sign posts to prohibition aluminum.
- As expound on the construction site or in the workshop.
- Suitable for exterior and interior. Good solvent resistance.
- The pictogram visible on the sign is useful in working environments where there are foreign workers.

Code	Desc.	Spessore cartello mm	Formato mm	Max reading distance mt
4460026790	31600	0,7	333X500	10
4460027285	32075	0,5	270X260	10



- Aluminum sign posts to prohibition.
- As expound on the construction site or in the workshop.
- Suitable for exterior and interior. Good solvent resistance.
- The pictogram visible on the sign is useful in working environments where there are foreign workers.

Code	Desc.	Spessore cartello mm	Formato mm	Max reading distance mt
4460026795	31605	0,7	166x262	6
4460027290	32080	0,7	166x210	6



- Aluminum sign posts to prohibition.
- As expound on the construction site or in the workshop.
- Suitable for exterior and interior. Good solvent resistance.
- The pictogram visible on the sign is useful in working environments where there are foreign workers.

Code	Desc.	Spessore cartello mm	Formato mm	Max reading distance mt
4460026800	31610	0,7	333X500	10
4460027300	32090	0,7	166x210	6



- Aluminum sign posts to prohibition.
- As expound on the construction site or in the workshop.
- Suitable for exterior and interior. Good solvent resistance.
- The pictogram visible on the sign is useful in working environments where there are foreign workers.

Code	Desc.	Spessore cartello mm	Formato mm	Max reading distance mt
4460026805	31615	0,7	333X500	10
4460026810	31620	0,7	116X233	6



- Aluminum sign posts to prohibition.
- As expound on the construction site or in the workshop.
- Suitable for exterior and interior. Good solvent resistance.
- The pictogram visible on the sign is useful in working environments where there are foreign workers.

Code	Desc.	Spessore <i>cartello mm</i>	Formato <i>mm</i>	Max reading distance <i>mt</i>
4460026815	31625	0,7	333X500	10
4460026820	31630	0,7	166X233	6



- Aluminum sign posts to prohibition.
- As expound on the construction site or in the workshop.
- Suitable for exterior and interior. Good solvent resistance.
- The pictogram visible on the sign is useful in working environments where there are foreign workers.

Code	Desc.	Spessore <i>cartello mm</i>	Formato <i>mm</i>	Max reading distance <i>mt</i>
4460026825	31635	0,7	270X370	10



- Aluminum sign posts to prohibition.
- As expound on the construction site or in the workshop.
- Suitable for exterior and interior. Good solvent resistance.
- The pictogram visible on the sign is useful in working environments where there are foreign workers.

Code	Desc.	Spessore <i>cartello mm</i>	Formato <i>mm</i>	Max reading distance <i>mt</i>
4460026830	31640	0,7	270X370	10



- Aluminum sign posts to prohibition.
- As expound on the construction site or in the workshop.
- Suitable for exterior and interior. Good solvent resistance.
- The pictogram visible on the sign is useful in working environments where there are foreign workers.

Code	Desc.	Spessore <i>cartello mm</i>	Formato <i>mm</i>	Max reading distance <i>mt</i>
4460026835	31645	0,7	270X370	10
4460026850	31660	0,7	166X233	6



- Aluminum sign posts to prohibition.
- As expound on the construction site or in the workshop.
- Suitable for exterior and interior. Good solvent resistance.
- The pictogram visible on the sign is useful in working environments where there are foreign workers.

Code	Desc.	Spessore cartello mm	Formato mm	Max reading distance mt
4460026855	31665	0,7	270X370	10



- Aluminum sign posts to prohibition.
- As expound on the construction site or in the workshop.
- Suitable for exterior and interior. Good solvent resistance.
- The pictogram visible on the sign is useful in working environments where there are foreign workers.

Code	Desc.	Spessore cartello mm	Formato mm	Max reading distance mt
4460026860	31670	0,7	270X370	10

## Fire signs



- Aluminum Fire Signs, with written and without.
- Suitable for exterior and interior. Good solvent resistance.
- The pictogram visible on the sign is useful in working environments where there are foreign workers.

Code	Desc.	Spessore cartello mm	Formato mm	Max reading distance mt
4460026870	31680	0,5	160X210	6
4460026865	31675	0,5	160X160	6



- Aluminum Fire Signs, with written and without.
- Suitable for exterior and interior. Good solvent resistance.
- The pictogram visible on the sign is useful in working environments where there are foreign workers.

Code	Desc.	Spessore cartello mm	Formato mm	Max reading distance mt
4460026875	31685	0,5	160X210	6





- Aluminum Fire Signs, with written and without.
- Suitable for exterior and interior. Good solvent resistance.
- The pictogram visible on the sign is useful in working environments where there are foreign workers.

Code	Desc.	Spessore cartello mm	Formato mm	Max reading distance mt
4460026880	31690	0,5	160X210	6
4460026885	31695	0,5	250X250	10



- Aluminum Fire Signs, with written and without.
- Suitable for exterior and interior. Good solvent resistance.
- The pictogram visible on the sign is useful in working environments where there are foreign workers.

Code	Desc.	Spessore cartello mm	Formato mm	Max reading distance mt
4460026890	31700	0,5	160X210	6
4460026895	31705	0,5	250X310	10



- Aluminum Fire Signs, with written and without.
- Suitable for exterior and interior. Good solvent resistance.
- The pictogram visible on the sign is useful in working environments where there are foreign workers.

Code	Desc.	Spessore cartello mm	Formato mm	Max reading distance mt
4460026900	31710	0,5	160x210	6

11

## Safety Signs



- Safety signs, in aluminum with written and without.
- To be displayed in public buildings and other workplaces.
- Suitable for exterior and interior. Good solvent resistance.
- The pictogram visible on the sign is useful in working environments where there are foreign workers.

Code	Desc.	Spessore cartello mm	Formato mm	Max reading distance mt
4460026905	31715	0,5	250X310	10



- Signs of safety, in aluminum with and without.
- To be displayed in public buildings and other workplaces.
- Suitable for exterior and interior. Good solvent resistance.
- The pictogram visible on the sign is useful in working environments where there are foreign workers.

Code	Desc.	Spessore cartello mm	Formato mm	Max reading distance mt
4460026910	31720	0,5	250X310	10



- Signs of safety, in aluminum with and without.
- To be displayed in public buildings and other workplaces.
- Suitable for exterior and interior. Good solvent resistance.
- The pictogram visible on the sign is useful in working environments where there are foreign workers.

Code	Desc.	Spessore cartello mm	Formato mm	Max reading distance mt
4460026915	31725	0,5	250X310	10



- Signs of safety, in aluminum with and without.
- To be displayed in public buildings and other workplaces.
- Suitable for exterior and interior. Good solvent resistance.
- The pictogram visible on the sign is useful in working environments where there are foreign workers.

Code	Desc.	Spessore cartello mm	Formato mm	Max reading distance mt
4460026920	31730	0,5	250X310	10



- Signs of safety, in aluminum with and without.
- To be displayed in public buildings and other workplaces.
- Suitable for exterior and interior. Good solvent resistance.
- The pictogram visible on the sign is useful in working environments where there are foreign workers.

Code	Desc.	Spessore cartello mm	Formato mm	Max reading distance mt
4460026925	31735	0,5	250X310	10



- Signs of safety, in aluminum with and without.
- To be displayed in public buildings and other workplaces.
- Suitable for exterior and interior. Good solvent resistance.
- The pictogram visible on the sign is useful in working environments where there are foreign workers.
- Scale emergency climb left.

Code	Desc.	Spessore cartello mm	Formato mm	Max reading distance mt
4460026930	31740	0,5	250X250	10

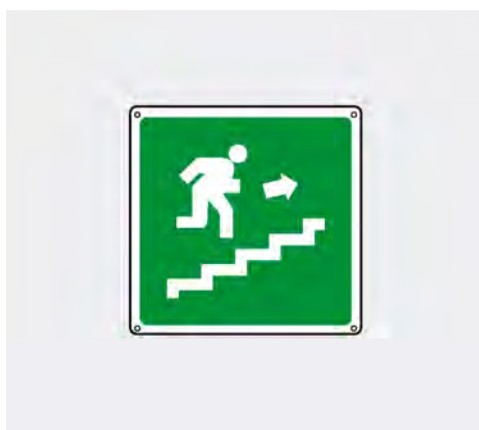

- Signs of safety, in aluminum with and without.
- To be displayed in public buildings and other workplaces.
- Suitable for exterior and interior. Good solvent resistance.
- The pictogram visible on the sign is useful in working environments where there are foreign workers.
- Scale emergency climb right.

Code	Desc.	Spessore cartello mm	Formato mm	Max reading distance mt
4460026935	31745	0,5	250X250	10

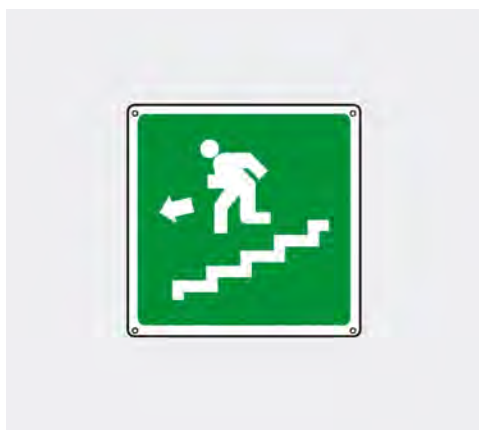

- Signs of safety, in aluminum with and without.
- To be displayed in public buildings and other workplaces.
- Suitable for exterior and interior. Good solvent resistance.
- The pictogram visible on the sign is useful in working environments where there are foreign workers.
- Scale emergency descent left.

Code	Desc.	Spessore cartello mm	Formato mm	Max reading distance mt
4460026940	31750	0,5	250X250	10



- Signs of safety, in aluminum with and without.
- To be displayed in public buildings and other workplaces.
- Suitable for exterior and interior. Good solvent resistance.
- The pictogram visible on the sign is useful in working environments where there are foreign workers.
- Scale emergency descent right.

Code	Desc.	Spessore cartello mm	Formato mm	Max reading distance mt
4460026945	31755	0,5	250X250	10

## Danger signs



- Signs of danger aluminum.
- Suitable for exterior and interior. Good solvent resistance.
- Indication as to expose on the construction site, or in other environments to indicate the presence of a hazard. Apply also on local hazards such as power plants: electrical panels, gas, heating, etc ...

Code	Desc.	Spessore cartello mm	Formato mm	Triangle side mm	Max reading distance mt
4460026950	31760	0,7	360X360	350	10



- Signs of danger aluminum.
- Suitable for exterior and interior. Good solvent resistance.
- Indication as to expose on the construction site, or in other environments to indicate the presence of a hazard. Apply also on local hazards such as power plants: electrical panels, gas, heating, etc ...

Code	Desc.	Spessore cartello mm	Formato mm	Triangle side mm	Max reading distance mt
4460026955	31765	0,7	360X360	350	10



- Signs of danger aluminum.
- Suitable for exterior and interior. Good solvent resistance.
- Indication as to expose on the construction site, or in other environments to indicate the presence of a hazard. Apply also on local hazards such as power plants: electrical panels, gas, heating, etc ...

Code	Desc.	Spessore cartello mm	Formato mm	Triangle side mm	Max reading distance mt
4460026956	31775	0,7	220X220	350	6



- Signs of danger aluminum.
- Suitable for exterior and interior. Good solvent resistance.
- Indication as to expose on the construction site, or in other environments to indicate the presence of a hazard. Apply also on local hazards such as power plants: electrical panels, gas, heating, etc ...

Code	Desc.	Spessore cartello mm	Formato mm	Triangle side mm	Max reading distance mt
4460026960	31770	0,7	360X360	350	10





- Signs of danger aluminum.
- Suitable for exterior and interior. Good solvent resistance.
- Indication as to expose on the construction site, or in other environments to indicate the presence of a hazard. Apply also on local hazards such as power plants: electrical panels, gas, heating, etc ...

Code	Desc.	Spessore cartello mm	Formato mm	Max reading distance mt
4460026970	31780	0,7	220X220	6
4460027295	32085	0,7	360X360	10



- Signs of danger aluminum.
- Suitable for exterior and interior. Good solvent resistance.
- Indication as to expose on the construction site, or in other environments to indicate the presence of a hazard. Apply also on local hazards such as power plants: electrical panels, gas, heating, etc ...

Code	Desc.	Spessore cartello mm	Formato mm	Max reading distance mt
4460026975	31785	0,7	333X500	10



- Signs of danger aluminum.
- Suitable for exterior and interior. Good solvent resistance.
- Indication as to expose on the construction site, or in other environments to indicate the presence of a hazard. Apply also on local hazards such as power plants: electrical panels, gas, heating, etc ...
- Symbol attention is forbidden to carry out work on live electrical equipment.

Code	Desc.	Spessore cartello mm	Formato mm
4460026985	31795	0,5	145X182



- Signs of danger aluminum.
- Suitable for exterior and interior. Good solvent resistance.
- Indication as to expose on the construction site, or in other environments to indicate the presence of a hazard. Apply also on local hazards such as power plants: electrical panels, gas, heating, etc ...

Code	Desc.	Spessore cartello mm	Formato mm	Max reading distance mt
4460026990	31780	0,5	350X125	4



- Signs of danger aluminum.
- Suitable for exterior and interior. Good solvent resistance.
- Indication as to expose on the construction site, or in other environments to indicate the presence of a hazard. Apply also on local hazards such as power plants: electrical panels, gas, heating, etc ...

Code	Desc.	Spessore cartello mm	Formato mm	Max reading distance mt
4460026995	31785	0,5	350x125	4



- Signs of danger aluminum.
- Suitable for exterior and interior. Good solvent resistance.
- Indication as to expose on the construction site, or in other environments to indicate the presence of a hazard. Apply also on local hazards such as power plants: electrical panels, gas, heating, etc ...

Code	Desc.	Spessore cartello mm	Formato mm	Max reading distance mt
4460027000	31790	0,5	350x125	4



- Signs of danger aluminum.
- Suitable for exterior and interior. Good solvent resistance.
- Indication as to expose on the construction site, or in other environments to indicate the presence of a hazard. Apply also on local hazards such as power plants: electrical panels, gas, heating, etc ...

Code	Desc.	Spessore cartello mm	Formato mm	Max reading distance mt
4460027005	31795	0,5	350x125	4

## Information signs



- Information signs aluminum.
- Suitable for exterior and interior. Good solvent resistance.
- Indication to be displayed on site or local, for information purposes.

Code	Desc.	Spessore cartello mm	Formato mm
4460027010	31800	0,7	333X500
4460027015	31805	0,5	165X250



- Aluminum information boards .
- Suitable for exterior and interior. Good solvent resistance.
- Indication to be displayed on site or local, for information purposes.

Code	Desc.	Spessore cartello mm	Formato mm
4460027020	31810	0,5	300X200



- Aluminum information boards .
- Suitable for exterior and interior. Good solvent resistance.
- Indication to be displayed on site or local, for information purposes.

Code	Desc.	Spessore <i>cartello mm</i>	Formato <i>mm</i>
4460027030	31820	0,5	300X200



- Aluminum information boards .
- Suitable for exterior and interior. Good solvent resistance.
- Indication to be displayed on site or local, for information purposes.

Code	Desc.	Spessore <i>cartello mm</i>	Formato <i>mm</i>
4460027035	31825	0,5	300X200



- Aluminum information boards .
- Suitable for exterior and interior. Good solvent resistance.
- Indication to be displayed on site or local, for information purposes.

Code	Desc.	Spessore <i>cartello mm</i>	Formato <i>mm</i>
4460027045	31835	0,5	300X200



- Aluminum information boards .
- Suitable for exterior and interior. Good solvent resistance.
- Indication to be displayed on site or local, for information purposes.

Code	Desc.	Spessore <i>cartello mm</i>	Formato <i>mm</i>
4460027050	31840	0,5	300X200



- Aluminum information boards .
- Suitable for exterior and interior. Good solvent resistance.
- Indication to be displayed on site or local, for information purposes.

Code	Desc.	Spessore cartello mm	Formato mm
4460027055	31845	0,5	300X200



- Aluminum information boards .
- Suitable for exterior and interior. Good solvent resistance.
- Indication to be displayed on site or local, for information purposes.

Code	Desc.	Spessore cartello mm	Formato mm
4460027060	31850	0,5	300X200



- Aluminum information boards .
- Suitable for exterior and interior. Good solvent resistance.
- Indication to be displayed on site or local, for information purposes.

Code	Desc.	Spessore cartello mm	Formato mm
4460027065	31855	0,5	300X200

### Adhesive labels non-removable



- Adhesive labels tamper, in plasticized vinyl film.
- Good resistance to aging, weathering, chemicals (acids, bases, alcohol).
- Flammable self-extinguishing ISO 3795. The products meet the European Regulatory Requirements under Directive 2002/95 (ROHS).
- Screen printing ink resistant to ultraviolet rays.
- Suitable for exterior and interior.
- Suitable for marking of electrical installations.
- Voltage symbol attention.

Code	Desc.	Formato foglio	Triangle side mm	N. Labels
4460027070	31860	175X115	50	10
4460027075	31865	200X85	22	30





- Adhesive labels tamper, in plasticized vinyl film.
- Good resistance to aging, weathering, chemicals (acids, bases, alcohol).
- Flammable self-extinguishing ISO 3795. The products meet the European Regulatory Requirements under Directive 2002/95 (ROHS).
- Screen printing ink resistant to ultraviolet rays.
- Suitable for exterior and interior.
- Suitable for marking of electrical installations.
- Symbol attention 230 volts.

Code	Desc.	Formato foglio	Triangle side mm	N. Labels
4460027080	31870	175X115	60	6
4460027085	31875	180X100	30	12



- Adhesive labels tamper, in plasticized vinyl film.
- Good resistance to aging, weathering, chemicals (acids, bases, alcohol).
- Flammable self-extinguishing ISO 3795. The products meet the European Regulatory Requirements under Directive 2002/95 (ROHS).
- Screen printing ink resistant to ultraviolet rays.
- Suitable for exterior and interior.
- Suitable for marking of electrical installations.
- Symbol attention 400 volts.

Code	Desc.	Formato foglio	Triangle side mm	N. Labels
4460027090	31880	175X115	60	6
4460027095	31885	180X100	30	12

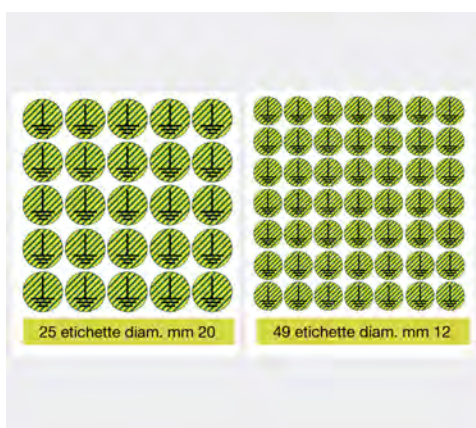

- Adhesive labels tamper, in plasticized vinyl film.
- Good resistance to aging, weathering, chemicals (acids, bases, alcohol).
- Flammable self-extinguishing ISO 3795. The products meet the European Regulatory Requirements under Directive 2002/95 (ROHS).
- Screen printing ink resistant to ultraviolet rays.
- Suitable for exterior and interior.
- Suitable for marking of electrical installations.
- Symbol grounding.

Code	Desc.	Formato foglio	Triangle side mm	N. Labels
4460027100	31890	140X140	20	25
4460027105	31895	125X125	12	49



- Adhesive labels tamper, in plasticized vinyl film.
- Good resistance to aging, weathering, chemicals (acids, bases, alcohol).
- Flammable self-extinguishing ISO 3795. The products meet the European Regulatory Requirements under Directive 2002/95 (ROHS).
- Screen printing ink resistant to ultraviolet rays.
- Suitable for exterior and interior.
- Suitable for marking of electrical installations.
- Symbol not open to unauthorized opening of the framework and 'allowed only for electricians.

Code	Desc.	Formato foglio	Triangle side mm	N. Labels
4460027110	31900	330X170	165X85	4
4460027115	31905	330X170	82X42	16



- Adhesive labels tamper, in plasticized vinyl film.
- Good resistance to aging, weathering, chemicals (acids, bases, alcohol).
- Flammable self-extinguishing ISO 3795. The products meet the European Regulatory Requirements under Directive 2002/95 (ROHS).
- Screen printing ink resistant to ultraviolet rays.
- Suitable for exterior and interior.
- Suitable for marking of electrical installations.
- Symbol here do not use water to extinguish fires.

Code	Desc.	Formato foglio	Triangle side mm	N. Labels
4460027120	31910	250X80	61X80	4
4460027125	31915	250X160	125X60	2





## Fastening elements

Fixings for plate holder . . . . .	pag. 1396	Fixing for upholstery. . . . .	pag. 1456
Plastic nuts. . . . .	pag. 1400	Fissaggi per targhette modello . . . . .	pag. 1458
Special plastic cable ties . . . . .	pag. 1405	Fixing for radiators. . . . .	pag. 1459
Fixings to lock rod and door. . . . .	pag. 1407	Fixing for carpets. . . . .	pag. 1460
Fixings wires and cables . . . . .	pag. 1409	Fixing for car doors. . . . .	pag. 1463
Fixings finishes and internal profiles . . . . .	pag. 1410	Screws fixing plate. . . . .	pag. 1477
Generic fixings. . . . .	pag. 1413	Plastic rivets . . . . .	pag. 1479
Generic fixings external body. . . . .	pag. 1431	Capping caps. . . . .	pag. 1484
Fixings guides of the side windows . . . . .	pag. 1434	Special screws and rivets. . . . .	pag. 1485
Fixings exterior moldings. . . . .	pag. 1436	Assortments . . . . .	pag. 1489
Fixing for Bumper and Fenders. . . . .	pag. 1445	Windscreen wiper. . . . .	pag. 1496
Fixing for windscreen. . . . .	pag. 1449	Car carpets . . . . .	pag. 1501
Fixing for wheel arches . . . . .	pag. 1453		



## Rivets Trimecc



- Indicated for the fixing of the plate holder to the license plate

Code	Measures	Color
506TA01500	4,8x16	Blue
506TA02200	4,8x16	White

## Graf rivets



- Rivets graf painted aluminum
- Indicated for the fixing of the plate holder to the license plate

Code	Desc. dxL	Color
3890002000	4,8x12	White Ral 9010
3890002100	4,8x12	Blue

## Blind rivets aluminum



- Specific for fixing plates
- Indicated for the fixing of the plate holder to the license plate

Code	Desc. dxL	Color	Spess. serr. mm
3850B02500	4,8x12/B mm	White RAL 9010	6,5÷8

## Colored screws



- Indicate per il fissaggio della targa tra portatarga e carrozzeria

Code	Measures	Color
3560401395	3,9x9,5	Blue
3560401400	4,2x16	Blue
3560401500	4,2x16	White
3560401600	Kit	7 Blue + 1 White

## Viti fissaggio TMT targhe



Code	Measures	Color
3560401405	4,2x18	Blu
3560401505	4,2x18	Biana

## Color caps for rivets and socket head cap screws



- Nylon caps which allow a remarkable aesthetic finish.
- Available in white and blue commonly used for license plates.
- For cheese head screws head diameter max 10mm (4.8 mm shank).
- Rivet diameter max 4.8 and 10mm head.
- White RAL 9002.
- Blue RAL 5017.
- For those intending to use screws and / or rivets standards without sacrificing the aesthetic finish on the car of the client.

Code	Desc.	Color
3560402065	26	Ral 9002
3560402070	27	Ral 5017



## Bottoni di fissaggio



- Indicated for the fixing of the plate holder to the license plate

Code	Desc.	Color
2940001000	370	Blue
2940001105	370B	White

## Bottoni di fissaggio



- Indicated for the fixing of the plate holder to the license plate

Code	Desc.	Color
2940085015	00603	White

## Bottone di fissaggio



- For fixing the old model license plates

Code	Desc.	Color
2940001100	371	Black

## Madreviti



Code	Desc.
2930000052	52

**Vite=Ø4,2 T=Ø10 Foro quadro=7  
52=Col. naturale**

Madrevite fissaggio  
targa immatricolazione Fiat 500, 126,  
Panda, Alfa 33, 75, 155, 164, Lancia  
Delta, prisma, Thema, Nuova Punto,  
Bravo, Brava.



Code	Desc.
2930000057	57

**Vite = Ø 4,2 T = Ø 16  
Foro quadro=7,5**

Colore naturale. Madrevite  
fissaggio targa immatricolazione Fiat  
126, Croma, Punto, Uno, Multipla, Lancia  
Y, Y10, Thema, Delta.



Code	Desc.
2930002302	2302

**Screw=Ø 4,8 T=Ø 13  
Square hole=7**

Natural color. nut screw for various  
applications Fiat Tipo, Tempra, Punto,  
Bravo / a, Palio, Marea, Ducato 290,  
Automobiles Alfa Romeo 145/146, Lancia  
Delta, Prisma, Y10, Thema, Automobiles  
Peugeot, Citroën.



Code	Desc.
2930005685	5685

**Vite=Ø 4,2 T=Ø 16  
Foro quadro=7**

Colore naturale. Madrevite fissaggio  
targhe A.R. Giulia 16> Fiat Panda 12>

## Paracolpo antivibrante

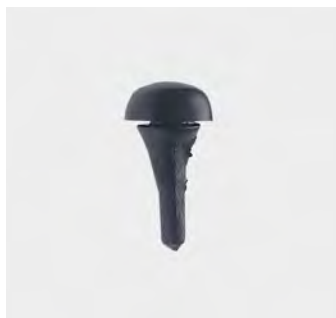

Code	Desc.
2930002072	2072

**H =4,5**

Paracolpo cofano H=4,5 in gomma  
usato anche come antivibrante per  
targhe.

## Aggancio centrale per portatarga



Code	Desc.	Color
3560400400	4332	Black
3560400300	4331	White

12

## Aggancio centrale piccolo per portatarga

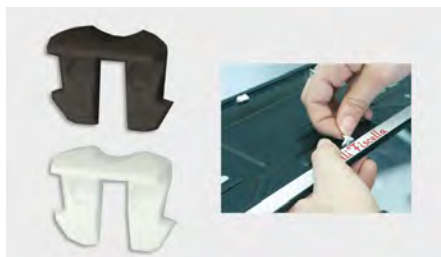

Code	Desc.	Color
3560400440	4333	White
3560400450	4334	Black

## Tapping screws Mushroom head with flange galvanized black



- Indicated for the fixing of the plate holder to the bodywork

Code	Measures	D head mm
3560401640	4,8x13	11,5
3560401645	4,8x16	11,5
3560401650	4,8x22	11,5

## Distanziali in gomma



- Used as spacers between bodywork and plate holder

Code	Desc.	Misure Ø int. X Ø est. X h
2940031600	52201	6x20x6
2940005900	5350	6x20x12
2940031599	52200	8x25x3

## Distanziale completo



- Used for fixing the license plate to the bodywork

Code	Measures
3560400100	6x25

## Viti TTDE zincate



Code	Measures
1820000200	6x25
1820000205	6x30

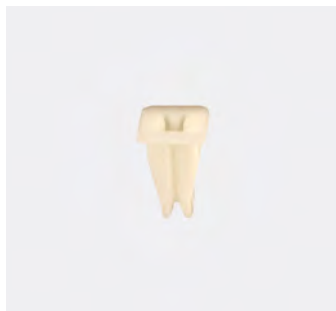

**BMW-Mini**

Code	Desc.
2930110950	10950

Ø vite o bullone: Ø 3,9 à 4,8  
Applicazioni: tutti i veicoli



Code	Desc.
2930112679	12679

Misure: 9 x 9  
Ø vite o bullone: Ø 5  
Applicazioni: Série 1, 3, 5, 5GT, 6, 7, X3



Code	Desc.
2930112680	12680

Misure: 7,1 x 7,1  
Ø vite o bullone: Ø 4,8  
Applicazioni: Serie 1, 3, 5, 6, 7, X1, X5, X6, Z4



Code	Desc.
2930112681	12681

Misure: 7 x 7  
Ø vite o bullone: Ø 5  
Applicazioni: BMW tutti itipi

**Ford**

Code	Desc.
2930110346	10346

Ø vite: 4  
Applicazioni: Ka, Fiesta, Escort



Code	Desc.
2930110349	10349

Ø vite: 4,8  
Applicazioni: Fiesta



Code	Desc.
2930110373	10373

Ø vite: 4,2  
Applicazioni: Ka, Fiesta, Escort, Focus, Mondeo



Code	Desc.
2930110778	10778

Ø vite: 6,35  
Applicazioni: Focus, Mondeo, C-Max



Code	Desc.
2930111386	11386

Ø vite: 5/6  
Applicazioni: Tutti i tipi



Code	Desc.
2930112237	12237

Ø vite: 4,5  
Applicazioni: Fiesta 2009, Ranger 2012

## Jeep



Code	Desc.
2930005675	5675

Bumper fixing nutsquare hole = 10 mm3.9 mm screwFor Fiat 500x and Jeep Renegade 14 p

## Nissan



Code	Desc.
2930112379	12379

Applicazioni: Tutti i tipi

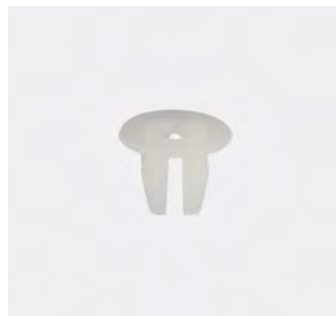

Code	Desc.
2930112541	12541

Misure: 8,5 x 8,5  
Ø vite o bullone: Ø 5 / 6  
Applicazioni: Note



Code	Desc.
2930112542	12542

Misure mm: 8,5 x 8,5  
Ø vite mm: Ø 5  
Applicazioni: Note, Juke, Qashqai



Code	Desc.
2930112551	12551

Misure mm: 8,5 x 8,5  
Ø vite mm: Ø 5/6  
Applicazioni: Qashqai



Code	Desc.
2930112553	12553

Ø vite mm: Ø 6  
Applicazioni: Note



Code	Desc.
2930112582	12582

Misure mm: 8,5 x 8,5  
Ø vite mm: Ø 6  
Applicazioni: Juke, Qashqai



Code	Desc.
2930112599	12599

Ø vite mm: Ø 5  
Applicazioni: Tutti i tipi



Code	Desc.
2930112600	12600

Ø vite mm: Ø 6  
Applicazioni: Tutti i tipi



Code	Desc.
2930112738	12738

Misure mm: 10 x 10  
 Ø vite mm: Ø 6  
 Applicazioni: Micra K13



Code	Desc.
2930112742	12742

Misure mm: 8,5 x 8,5  
 Ø vite mm: Ø 6  
 Applicazioni: Tutti i tipi



Code	Desc.
2930112747	12747

Misure mm: 9,5 x 4,5  
 Ø vite mm: Ø 6  
 Applicazioni: Tiida CII, Note E12 Micra K11/12/13



Code	Desc.
2930112748	12748

Misure mm: 10 x 10  
 Ø vite mm: Ø 6  
 Applicazioni: Micra K13, Cube A12

## Peugeot-Citroën

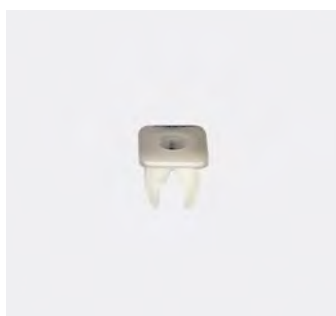

Code	Desc.
2930100218	218

Misure mm: 7 x 7  
 Applicazioni: Partner, Berlingo



Code	Desc.
2930100477	477

Misure mm: 11,2 x 11,2  
 Applicazioni: 207, 309, 607, 1007, Partner, C3, C5, Berlingo



Code	Desc.
2930101317	1317

Misure mm: 7 x 7  
 Applicazioni: Tutti i tipi



Code	Desc.
2930101319	1319

Misure mm: 7,2 x 14,2  
 Applicazioni: Tutti i tipi



Code	Desc.
2930109237	9237

Misure mm: 7,2 x 14,2  
 Applicazioni: 106, 806, 807, Partner, Saxo, Xsara, C8, Berlingo



Code	Desc.
2930109487	9487

Misure mm: 6,5 x 6,5  
 Applicazioni: Tutti i tipi



Code	Desc.
2930109941	9941

Misure mm: 8,2 x 8,2  
 Applicazioni: 206, 406



Code	Desc.
2930110011	10011

Misure mm: 7,2 x 7,2  
 Applicazioni: Tutti i tipi

## Plastic nuts



Code	Desc.
2930111705	11705

Misure mm: 7,2 x 14,2  
Applicazioni: C3 A51, 308 CC



Code	Desc.
2930111712	11712

Misure mm: 7,2 x 14,2  
Applicazioni: 308 SW, 3008



Code	Desc.
2930111982	11982

Applicazioni: C5, X7

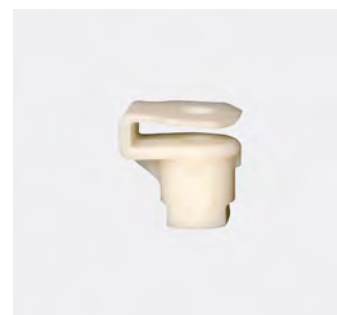

Code	Desc.
2930112020	12020

Applicazioni: 207, B9, 3008, 5008



Code	Desc.
2930112102	12102

Misure mm: 8,2 x 8,2  
Ø viti autofilettanti: Ø 4,2 o 4,5  
Ø viti per i materiali morbidi: Ø 4,5 o 5  
Applicazioni: 3008, 5008, C3 Picasso



Code	Desc.
2930112800	12800

Plastic nut for M5 screws  
Applications: Citroen, Peugeot



Code	Desc.
2930005620	5620

11.3 mm square hole  
For M6 screws - 20 mm head  
For applications on bumper-underbody  
Citroen c3-c4 -ds3-ds4-ds5-Jumpy II  
Peugeot 207-patner RCZ

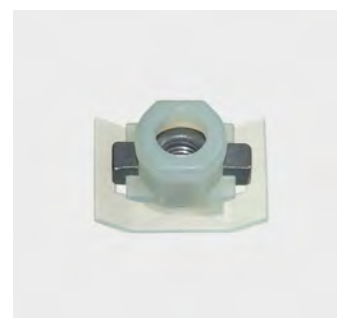

Code	Desc.
2930005625	5625

- 11.3 mm square hole
- For M6 screws - 15x22 mm head
- For applications on under enginecovers, Citroen carpet floor matsjumpy III-IV Peugeot expert IIIIV

## Renault-Dacia



Code	Desc.
2930100218	218

Misure mm: 7 x 7  
Ø viti autofilettanti: Ø 4,2  
Ø viti per i materiali morbidi: Ø 4,5  
Applicazioni: Tutti i tipi



Code	Desc.
2930101319	1319

Misure mm: 7,2 x 14,2  
Applicazioni: Tutti i tipi



Code	Desc.
2930109237	9237

Misure mm: 7,2 x 14,2  
Applicazioni: 106, 806, 807, Partner, Saxo, Xsara, C8, Berlingo



Code	Desc.
2930110991	10991

Per viti VMT: Ø 5  
Applicazioni: Twingo II, Scenic II





Code	Desc.
2930111441	11441

Per vite prigioniera: 5 mm  
 Applicazioni: tutti i tipi



Code	Desc.
2930111712	11712

Misure mm: 7,2 x 14,2  
 Ø viti autofilettanti: Ø 4,2  
 Ø viti per i materiali morbidi: Ø 4,5  
 Applicazioni: Tutti i tipi

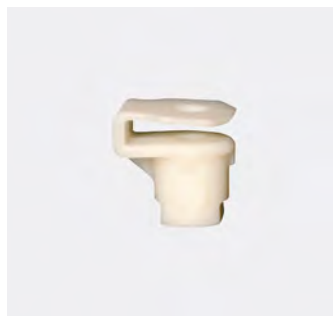

Code	Desc.
2930112020	12020

Ø viti per i materiali morbidi: Ø 5  
 Applicazioni: Scenic III, Megane III CC

## Plastic bands



Foratura: Ø 6,5 mm  
Serraggio Ø mm: 2-28  
Long. x larghezza. mm: 150 x 5  
Materiale: Poliammide 6.6  
Colore: Nero

Code	Desc.
2930100764	764

## Plastic bands



Ø foro = 6,5/8 4,6x215 mm  
Fascetta plastica, varie applicazioni.

Code	Desc.
2930000825	825

## Plastic bands



- Ø foro = 6,5/7 4,7x200 mm
- Fascetta plastica, varie applicazioni Volkswagen.

Code	Desc.
2930000826	826

## Plastic bands



Ø foro = 6 4,5x140 mm  
Colore nero. Fissaggio cavi nel vano motore Volkswagen, Audi.

Code	Desc.
2930000828	828

## Plastic bands



**8x180 mm**

Colore nero. Fissaggio cavi nel vano motore Volkswagen, Audi.

Code	Desc.
2930000830	830

## Plastic bands



**Ø foro = 8 7x160 mm**

**Riapribile.** Fascetta varie applicazioni Fiat, Lancia, Alfa Romeo.

Code	Desc.
2930002056	2056

## Fiat



Code	Desc.
2930002248	2248

Colour white. Bushing for rod of door Fiat Bravo, Brava, Marea.

## Peugeot-Citroën



Code	Desc.
2930100446	446

Ø asta mm: da 2,5 a 4  
Applicazione: tutti i tipi



Code	Desc.
2930101172	1172

Ø asta mm: 3  
Applicazione: tutti i tipi



Code	Desc.
2930101276	1276

Ø asta mm: 3  
Applicazione: 306, Partner Xantia, Berlingo



Code	Desc.
2930101279	1279

Ø asta mm: 3  
Applicazione: 206, 306, 307, 406, C4 Picasso, C5



Code	Desc.
2930101361	1361

Ø asta mm: 3 à 3,5  
Applicazione: 307, 806, Evasion



Code	Desc.
2930101362	1362

Ø asta mm: 3  
Applicazione: Tutti i tipi

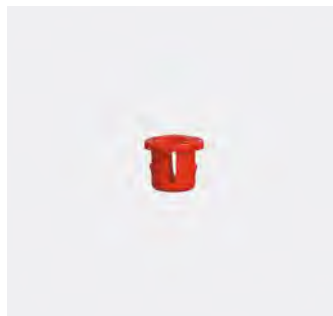

Code	Desc.
2930101363	1363

Ø asta mm: 3,5  
Applicazione: Tutti i tipi



Code	Desc.
2930101394	1394

Ø asta mm: 7  
Applicazione: Capot / Bonnet 106, 306, AX, Saxo, C2, C3, C4 Picasso, C15





Code	Desc.
2930110493	10493

Ø asta mm: 3  
Applicazione: 307, C5



Code	Desc.
2930111269	11269

Ø asta mm: 7,2  
Applicazione: Capot / Bonnet - Partner, C4 Picasso, Berlingo



Code	Desc.
2930005640	5640

Bonnet rod fixing  
Application: Citroen C3-PicassoC4cactus-PicassoDs3Jumpy IVSpacetourerPeugeot2008-207-208-3008(P84)308(T9)-Expert-4(KO)-Traveller

## Renault-Dacia



Code	Desc.
2930100446	446

Ø asta mm: 2,5 à 4  
Applicazione: Vecchi modelli



Code	Desc.
2930101276	1276

Ø asta mm: 3  
Applicazione: Kangoo



Code	Desc.
2930101361	1361

Ø asta mm: 3 a 3,5  
Applicazione: R5, R19, R21, R9/11, R25, Clio, Logan

## Ford

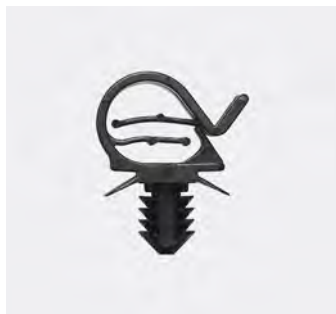

Code	Desc.
2930110357	10357

Ø filo mm: 3 a 10  
Applicazione: Tutti i tipi

## Fiat



Code	Desc.
2930000159	159

Ø=8  
Color: Grey. Strap for various applications. universal

## Fiat-Alfa Romeo-Lancia



Code	Desc.
2930109783	9783

Applicazione: Tutti i tipi



Code	Desc.
2930109832	9832

Misure mm: 6.7 x 6.7  
Ø Vite mm: 3,5 di 4,2



Code	Desc.
2930110753	10753

Applicazione: Radiatore Scudo



Code	Desc.
2930110754	10754

Applicazione: Radiatore Scudo

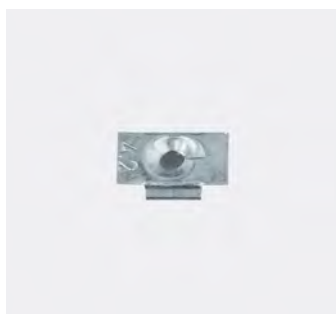

Code	Desc.
2930110870	10870

Ø vite mm: 4,2  
Applicazione: Tutti i tipi



Code	Desc.
2930111793	11793

Applicazione: coperture  
fonoassorbenti tutti i tipi



Code	Desc.
2930112139	12139

Ø vite mm: 4,8  
Applicazione: Tutti i tipi



Code	Desc.
2930005645	5645

Burnished self-tapping screw Size 4.8  
x16- torx TX25 Head 14 mm  
diameter Applications: interiors, bumper,  
rocker panel, Alfa R. projector  
lamps Giulia 16- Stelvio 17- Fiat 500-12-  
Jeep Renegade 14-

## Peugeot-Citroën



Code	Desc.
2930101344	1344

Applicazione: Fourchette / Yoke 106,  
306, 405, 406 AX, Saxo, ZX, XM



Code	Desc.
2930101347	1347

Misure mm: Ø 4,7  
Applicazione: Peugeot, Citroën tutti i tipi

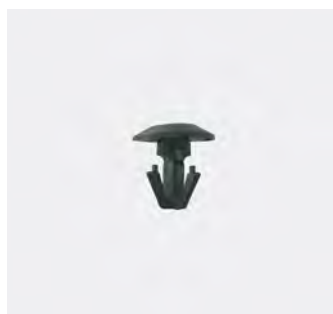

Code	Desc.
2930110029	10029

Misure mm: Ø 5,2  
Applicazione: 1007, 207, 307, 407,  
Xsara, C5, C6

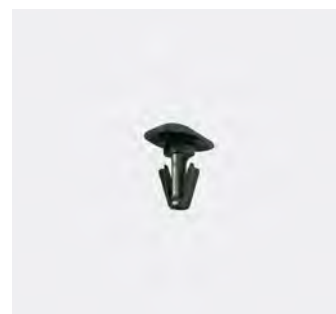

Code	Desc.
2930110748	10748

Misure mm: Ø 5  
Applicazione: 807, C4 Picasso, C8



Code	Desc.
2930111320	11320

Misure mm: Ø 5,2  
Applicazione: 307, 407 Coupé

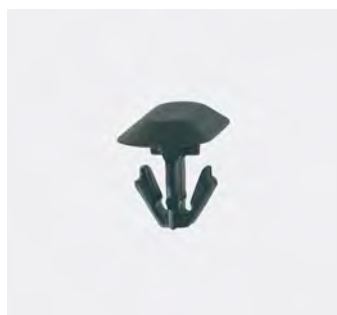

Code	Desc.
2930111452	11452

Misure mm: Ø 5,2 à 6,2  
Applicazione: 307, 407, 607 Xsara, C4, Expert, Jumpy



Code	Desc.
2930111453	11453

Impronta: Torx  
Applicazione: Ali anteriori 307, 308, C4



Code	Desc.
2930111469	11469

Impronta: Torx  
Applicazione: 307 I-II, 3008



Code	Desc.
2930111629	11629

Misure mm: Ø 5,2  
Applicazione: 308, 3008, 308 T9



Code	Desc.
2930111740	11740

Misure mm: Ø 5,1  
Applicazione: 308, 3008, C4 Picasso, C5 X7, Partner, Berlingo



Code	Desc.
2930111927	11927

Applicazione: Qualsia motore HDI tutti i tipi



Code	Desc.
2930111936	11936

Applicazione: Qualsia motore HDI tutti i tipi



Code	Desc.
2930112207	12207

Applicazione: Vetri Boxer III, Jumper III



## Renault-Dacia



Code	Desc.
2930101380	1380

Anello di tenuta  
Misure mm: Ø 5,2  
Applicazione: Laguna, Safrane



Code	Desc.
2930110029	10029

Anello di tenuta  
Misure mm: Ø 5,2  
Applicazione: Kangoo, Laguna, Master



Code	Desc.
2930110843	10843

Anello di tenuta  
Misure mm: Ø 5 a 6  
Applicazione: Megane II, Scenic II



Code	Desc.
2930110854	10854

Anello di tenuta  
Misure mm: Ø 5,2  
Applicazione: Megane II et III, Scenic III, Vel Satis

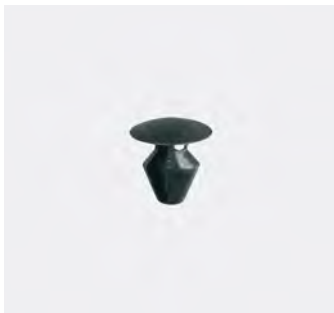

Code	Desc.
2930111337	11337

Anello di tenuta  
Misure mm: Ø 5,2  
Applicazione: Megane CC, Scenic II



Code	Desc.
2930111417	11417

Anello di tenuta  
Misure mm: Ø 8 a 8,2  
Applicazione: Vel Satis, Laguna III



Code	Desc.
2930111584	11584

Anello di tenuta  
Misure mm: Ø 6,2  
Applicazione: Kangoo II, Trafic II



Code	Desc.
2930111740	11740

Anello di tenuta  
Misure mm: Ø 5,1  
Applicazione: Kangoo II, Laguna, coupé III

## BMW-Mini



Code	Desc.
2930112043	12043

Applicazioni: Scuttle - E32, E34



Code	Desc.
2930112678	12678

Misure mm: Ø 7  
Applicazioni: BMW tutti i tipi 2005>

## Fiat



Code	Desc.
2930000302	302

**T=Ø 16 L=16 Foro Ø=8**  
Colore nero. Bottone fissaggio rivestimenti interni vetture Fiat, Lancia, Alfa Romeo tutti modelli.



Code	Desc.
2930004795	4795

**T=Ø 22 F= 6,5.**  
Rivetto in plastica cofano motore Scudo, Ulisse, Phedra, 206. Locari passaruota Ulisse, Phedra, 206. Mascherina radiatore 206. Pannello porta 306. Colore nero.



Code	Desc.
2930000058	58

**Vite = Ø 3,5 Foro quadro=7,5**  
Madrevite fissaggio rivestimenti Fiat Bravo, Brava, Iveco, VW Golf, Lupo, Passat, New beetle.



Code	Desc.
2930000338	338

Graffetta fissaggio modanatura porta Peugeot 206, 806. Modanatura laterale Stilo.



Code	Desc.
2930000073	73

**Ø=M6**  
Zincatura gialla. Dado con rondella mobile per varie applicazioni - Fiat Nuova Punto - Renault Megane, Laguna - Peugeot - Volkswagen - Ford.



Code	Desc.
2930000874	874

**874=6x18**  
Steel washer fixing fenders trucks.



Code	Desc.
2930000294	294

**T=Ø 15 L=16 Hole Ø=6,5**  
Color: Grey. Button fastening interior trim Fiat Vans, Trucks.

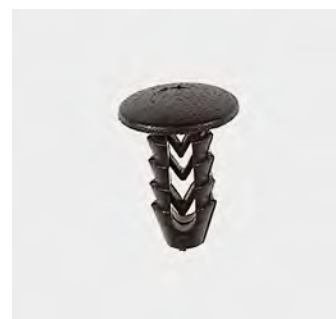

Code	Desc.
2930000293	293

**T=Ø 15 L=16 Hole Ø=6,5**  
Black Colour. Button fastening interior trim Automobiles Fiat New Punto, Lancia Lybra, Alfa Romeo.



Code	Desc.
2930000319	319

**T=Ø 20 L=17 Hole Ø=6,5**  
Black Colour. Button Mounting interior trim Fiat Multipla - Lybra Lancia, Alfa Romeo.



Code	Desc.
2930002059	2059

**T=Ø 24 L=17 hole Ø=8,5**  
Black Colour. Button Mounting coatings Fiat Bravo, Brava, Marea, Fiat Ducato, 145-146 Alfa, Lancia Dedra.



Code	Desc.
2930000326	326

**T=Ø 20 L=13 hole Ø=6,5**  
Black Colour. Button Mounting insulation hood Fiat Uno, Cinquecento, Palio, Punto, Bravo, Brava, Multipla, Lybra.



Code	Desc.
2930000324	324

**T=Ø 25 L=16 hole Ø=6,5**  
Black Colour. Button Mounting interior trim Fiat.



Code	Desc.
2930000565	565

**T=Ø 15 hole Ø=6,5**  
Black Colour. Rivet fastening interior trim Fiat Uno, Tempra, Cromia, point, Vans, Alfa 75, 90, 155, 164, Lancia Dedra.



Code	Desc.
2930000288	288

**T=Ø 20 L=17 Hole Ø=6,5**  
Black Colour. Button Mounting interior trim - Fiat.



Code	Desc.
2930000367	367

**T=Ø 15 L=13 hole Ø=6,5**  
Black Colour. Button Mounting interior trim - Fiat - Lancia - Alfa Romeo. Locari wheel arches Fiat Multipla.



Code	Desc.
2930000585	585

**hole Ø=8**  
Yellow color. Button panel blocking door Fiat Tipo, Tempra, Lancia Delta, Prisma.



Code	Desc.
2930000349	349

**T=Ø 20 L=29 hole Ø=6,5**  
Black Colour. Button Mounting interior trim Fiat Uno.



Code	Desc.
2930000612	612

Natural color. Clip fastening sills Fiat Punto GT Convertible, New Punto.



Code	Desc.
2930005680	5680

Applications: Rocker panel - side sill moulding Fiat 500x side rocker panel sill moulding Jeep Renegade 14-P

## Ford



Code	Desc.
2930110345	10345

Misure mm: Ø 6,3 à 7,5  
Applicazioni: Focus, C-Max, S-Max, Galaxy, Mondeo



Code	Desc.
2930110351	10351

Applicazioni: Tutti i tipi



Code	Desc.
2930110356	10356

Misure mm: Ø 8,4  
Applicazioni: Fiesta, Escort, Mondeo, Connect



Code	Desc.
2930110361	10361

Applicazioni: Ka, Fiesta, Escort



Code	Desc.
2930110804	10804

Misure mm: Ø 8,4  
Applicazioni: Ka



Code	Desc.
2930110817	10817

Misure mm: Ø 10  
Applicazioni: paraurti Ka



Code	Desc.
2930111619	11619

Misure mm: 5,7 a 6,6  
Applicazioni: S-Max, Galaxy, Mondeo



Code	Desc.
2930111620	11620

Misure mm: Ø 5,5  
Applicazioni: Tutti i tipi



Code	Desc.
2930111622	11622

Misure mm: Ø 6,25  
Applicazioni: S-Max, Galaxy, Mondeo



Code	Desc.
2930111633	11633

Misure mm: 10 x 20  
Applicazioni: S-Max, Galaxy, Mondeo



Code	Desc.
2930112232	12232

Misure mm: Ø 8  
Applicazioni: Fiesta 2009



Code	Desc.
2930112233	12233

Misure mm: Ø 6,2 à 6,7  
Applicazioni: Tutti i tipi





Code	Desc.
2930112570	12570

Misure mm: Ø 5,2  
Applicazioni: guarnizioni porte tutti i tipi



Code	Desc.
2930112638	12638

Misure mm: Ø 8  
Applicazioni: Fiesta 2008>, B-Max >2012



Code	Desc.
2930112639	12639

Misure mm: Ø 8,7 a 9,1  
Applicazioni: Fiesta 2008>, B-Max 2012>, EcoSport



Code	Desc.
2930112640	12640

Misure mm: Ø 6,2 a 6,5  
Applicazioni: C-Max >2011, Focus >2011, Kuga, Transit Connect, Explorer, Ranger



Code	Desc.
2930111473	11473

Misure mm: Ø 6.8  
Applicazione: Focus 2011



Code	Desc.
2930004945	4945

**Ø=4,8x14**  
Vite autofilettante per rivestimenti e ripari Opel, Volkswagen, Ford. Zincatura nera

## Honda



Code	Desc.
2930111754	11754

Applicazioni: Guarnizioni interne Civic

## Iveco



Code	Desc.
2930000331	331

Colore grigio. Molletta fissaggio modanatura New Daily.



Code	Desc.
2930000332	332

Colore bianco. Molletta fissaggio modanatura New Daily.

## Kia



Code	Desc.
2930112709	12709

Applicazioni: Cerato, Sorento, Carnival, Optima, Sedona, Sportage, Soul

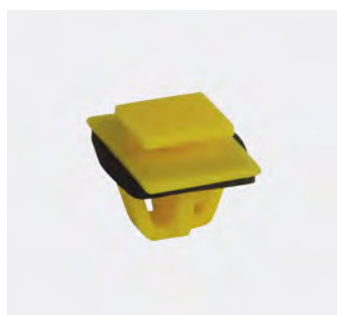

Code	Desc.
2930112710	12710

Applicazioni: Picanto, Morning

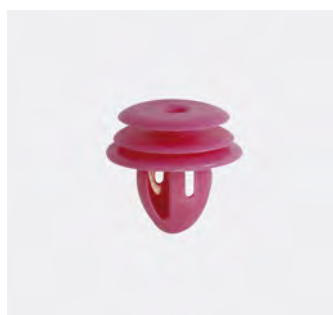

Code	Desc.
2930112711	12711

Applicazioni: Carens, Carnival, Sedona, Cee'd, Cerato, Forte, Optima, Rio, Soul, Sportage, Venga



Code	Desc.
2930112712	12712

Applicazioni: Cadenza, Cee'd, Optima, Picanto, Morning, Rio, Sorento, Soul, Sportage



Code	Desc.
2930112713	12713

Applicazioni: Carens, Rio, Picanto, Sorento, Soul, Sephia, Shuma, Mentor, Sportage



Code	Desc.
2930112714	12714

Applicazioni: Cadenza, Carnival, Sedona, Cerato, Optima, Rio



Code	Desc.
2930112715	12715

Applicazioni: Cadenza, Carnival, Sedona, Cee'd, Cerato, Forte, Optima, Picanto, Hyundai tutti i modelli



Code	Desc.
2930112716	12716

Applicazioni: Optima, Magenti, Soul, Sportage, Rio, Sorento, Picanto, Cerato, Cee'd, Carnival

## Mercedes-Smart



Code	Desc.
2930111008	11008

Misure mm: 11 x 14  
Applicazioni: tutti i tipi



Code	Desc.
2930111938	11938

Misure mm: Ø 8  
Applicazioni: Sprinter



Code	Desc.
2930111960	11960

Misure mm: Ø 8  
Applicazioni: Tutti i tipi



Code	Desc.
2930112388	12388

Misure mm: Ø 4,75  
Applicazioni: Tutti i tipi



Code	Desc.
2930112439	12439

Misure mm: Ø 8,5  
Applicazioni: Scatola sotto motore

## Nissan

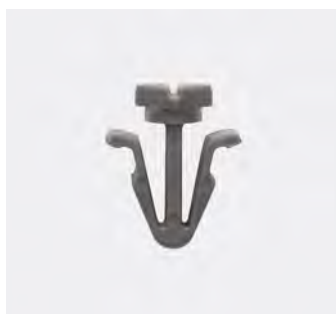

Code	Desc.
2930112378	12378

Applicazioni: Tutti i tipi

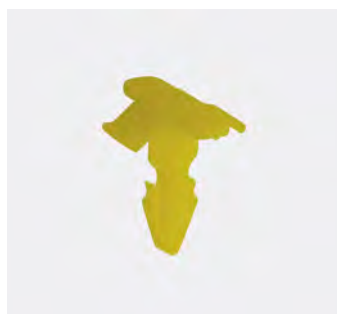

Code	Desc.
2930112537	12537

Applicazioni: Micra, Juke, Note



Code	Desc.
2930112549	12549

Misure mm: Ø 8  
Applicazioni: Carena, assetto tutti i tipi



Code	Desc.
2930112550	12550

Misure mm: Ø 5,2  
Applicazioni: capote insonorizzata tutti i tipi



Code	Desc.
2930112570	12570

Misure mm: Ø 5,2  
Applicazioni: Guarnizioni porta tutti i tipi

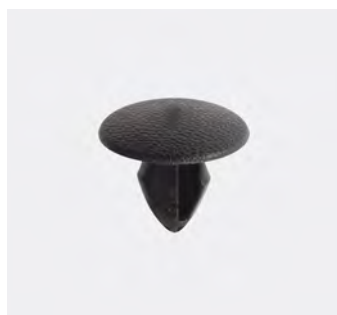

Code	Desc.
2930112737	12737

Misure mm: Ø 8  
Applicazioni: Mika K13, NU200, Almera, N15/N16

## Opel



Code	Desc.
2930110262	10262

Misure mm: Ø 7,9 a 8,7  
Applicazioni: cofano Tutti i tipi



Code	Desc.
2930110330	10330

Misure mm: Ø 5,9 a 7,1  
Applicazioni: Tutti i tipi



Code	Desc.
2930110332	10332

Misure mm: Ø 7  
Applicazioni: Cofano motore Corsa B et C, Astra G, Zafira, Vectra A, B et C



Code	Desc.
2930110995	10995

Misure mm: 7,2 x 7,2  
Applicazioni: Tutti i tipi



Code	Desc.
2930111008	11008

Misure mm: 11 x 14  
Applicazioni: Tutti i tipi



Code	Desc.
2930111061	11061

Misure mm: Ø 6  
Applicazioni: Tutti i tipi



Code	Desc.
2930111100	11100

Misure mm: Ø 6  
Applicazioni: Tutti i tipi



Code	Desc.
2930111160	11160

Ø Vite: 5 mm  
Applicazioni: Corsa C, Vectra B, Astra G, Zafira,





Code	Desc.
2930112233	12233

Misure mm: Ø 3,2 a 6,7  
Applicazioni: Tutti i tipi



Code	Desc.
2930112444	12444

Misure mm: Ø 7,2 à 7,5  
Spessore mm: 0,7 a 4  
Applicazioni: Tutti i tipi



Code	Desc.
2930004945	4945

**Ø=4,8x14**  
Vite autofilettante per rivestimenti e ripari Opel, Volkswagen, Ford. Zincatura nera

## Peugeot-Citroën



Code	Desc.
2930100421	421

Misure mm: Ø 5,5  
Applicazioni: Tutti i tipi



Code	Desc.
2930101177	1177

Misure mm: Ø 6,7  
Applicazioni: Testa larga 20 mm 106, 306, BX, CX, C15



Code	Desc.
2930101232	1232

Misure mm: 5 x 14  
Applicazioni: Bottone di fissaggio insonorizzazione su perno



Code	Desc.
2930101267	1267

Misure mm: Ø 6,5  
Applicazioni: tutti i tipi



Code	Desc.
2930101348	1348

Misure mm: Ø 4,7  
Applicazioni: 106, 205, 206, 306, 807, Xsara, Picasso, C8



Code	Desc.
2930101349	1349

Misure mm: Ø 6,5  
Applicazioni: Guarnizioni interne 106, 306, Saxo, ZX



Code	Desc.
2930101350	1350

Misure mm: Ø 6,5  
Applicazioni: Guarnizioni interne 106, 306, Saxo, ZX



Code	Desc.
2930101353	1353

Misure mm: Ø 6,5  
Applicazioni: 106, Partner AX, Saxo, ZX, Xantia, Berlingo

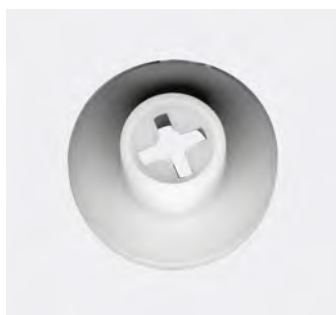

Code	Desc.
2930101357	1357

Applicazioni: Bottone di fissaggio insonorizzazione su perno

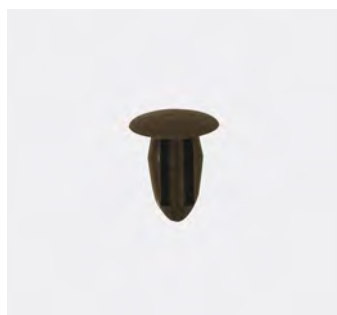

Code	Desc.
2930109448	9448

Misure mm: Ø 6,5  
Applicazioni: ZX, Picasso, C5, C15



Code	Desc.
2930109789	9789

Misure mm: Ø 6,2  
Applicazioni: Tutti i tipi

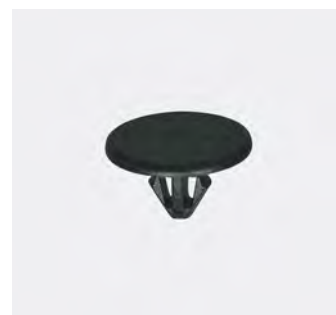

Code	Desc.
2930109841	9841

Misure mm: Ø 6,2  
Applicazioni: Tutti i tipi



Code	Desc.
2930110010	10010

Misure mm: Ø 6,3 à 6,7  
Applicazioni: Xsara, Picasso, Berlingo 407, C6



Code	Desc.
2930110417	10417

Misure mm: Ø 6,2 a 6,7  
Applicazioni: 07, Saxo ph.2, C2, C5 ph. 2, 207, C6, C3 II, DS3



Code	Desc.
2930110473	10473

Misure mm: Ø 6,2  
Applicazioni: Portellone Picasso

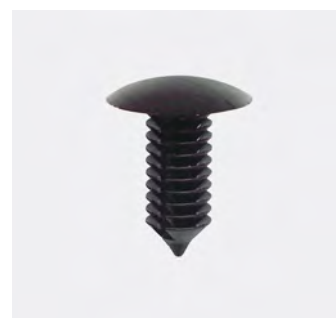

Code	Desc.
2930110591	10591

Misure mm: Ø 7,15  
Applicazioni: 307, Xsara II, C4



Code	Desc.
2930110750	10750

Misure mm: Ø 6,5  
Applicazioni: 407, C3, C4 Expert, Jumpy



Code	Desc.
2930111240	11240

Misure mm: Ø 5,2  
Applicazioni: bottone di fissaggio 407, C5



Code	Desc.
2930111376	11376

Misure mm: Ø 8,2  
Applicazioni: portellone 407 SW

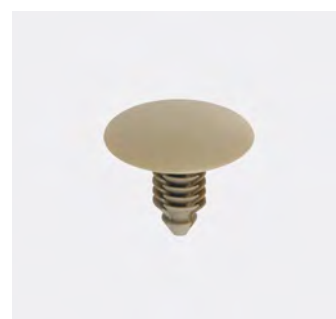

Code	Desc.
2930111391	11391

Misure mm: Ø 6,5  
Applicazioni: 407



Code	Desc.
2930111520	11520

Misure mm: Ø 6,5  
Applicazioni: 207, 1007



Code	Desc.
2930000338	338

Graffetta fissaggio modanatura porta Peugeot 206, 806. Modanatura laterale Stilo.

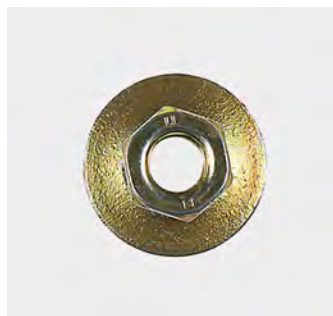

Code	Desc.
2930000073	73

**Ø=M6**  
Zincatura gialla. Dado con rondella mobile per varie applicazioni - Fiat Nuova Punto - Renault Megane, Laguna - Peugeot - Volkswagen - Ford.

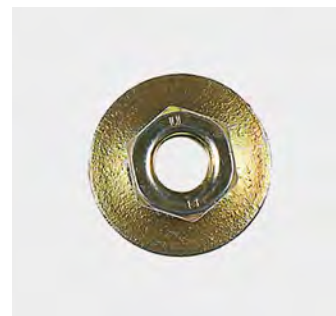

Code	Desc.
2930000072	72

**Ø M8**  
Dado con rondella mobile per varie applicazioni - Renault Twingo, Clio - Peugeot 605.



Code	Desc.
2930112903	12903

Silent block air filter -All V6 engines  
Applications: Citroen, Peugeot

## Renault-Dacia



Code	Desc.
2930100470	470

Misure mm: Ø 6,5  
Applicazioni: tutti i tipi



Code	Desc.
2930101177	1177

Misure mm: Ø 6,7  
Applicazioni: Testa larga 20 mm



Code	Desc.
2930101179	1179

Misure mm: Ø 10,4 à 11,4  
Applicazioni: tutti i tipi



Code	Desc.
2930101180	1180

Misure mm: Ø 7  
Applicazioni: Testa larga - 20 mm

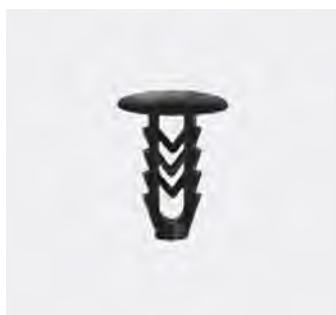

Code	Desc.
2930101229	1229

Misure mm: Ø 6,5  
Applicazioni: Tutti i tipi



Code	Desc.
2930101349	1349

Misure mm: Ø 6,5  
Applicazioni: R19



Code	Desc.
2930101353	1353

Misure mm: Ø 6,5  
Applicazioni: R19, Twingo



Code	Desc.
2930101355	1355

Misure mm: Ø 8,2  
Applicazioni: Tutti i tipi

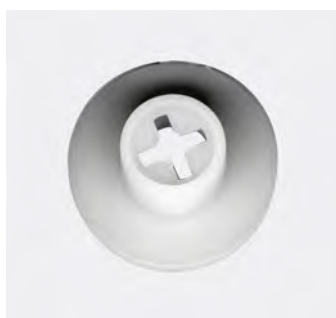

Code	Desc.
2930101357	1357

Misure mm: Ø 8,2  
Applicazioni: Tutti i tipi



Code	Desc.
2930109987	9987

Misure mm: Ø 6,5  
Applicazioni: insonorizzazione cofano motore tutti i tipi

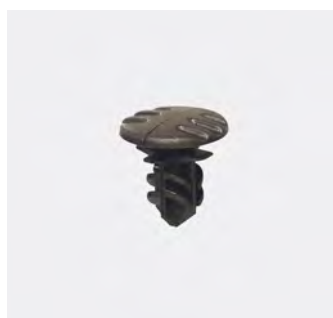

Code	Desc.
2930109993	9993

Misure mm: Ø 6,7  
Applicazioni: Kangoo



Code	Desc.
2930110017	10017

Misure mm: Ø 8,2  
Applicazioni: Clio II, Kangoo, Trafic



Code	Desc.
2930110135	10135

Misure mm: Ø 6,7  
Applicazioni: Insonorizzazione cofano motore Laguna ph.2

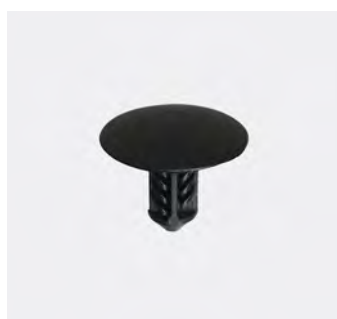

Code	Desc.
2930110226	10226

Misure mm: Ø 6,7  
Applicazioni: Insonorizzazione cofano motore tutti i tipi



Code	Desc.
2930110548	10548

Misure mm: Ø 5,3 à 5,8  
Applicazioni: Clio III, Laguna II, Espace IV



Code	Desc.
2930110881	10881

Applicazioni: Bottone di fissaggio Insonorizzazione su perno M6 tutti i tipi





Code	Desc.
2930110892	10892

Misure mm: Ø 6,2



Code	Desc.
2930111107	11107

Misure mm: 12 x 14,2  
Applicazione: Modus



Code	Desc.
2930111274	11274

Misure mm: Ø 8,2  
Applicazione: Kangoo II Master II



Code	Desc.
2930111853	11853

Misure mm: Ø 8,2  
Applicazione: Kangoo II



Code	Desc.
2930111855	11855

Misure mm: Ø 6,7  
Applicazione: Kangoo III



Code	Desc.
2930111858	11858

Misure mm: Ø 8,2  
Applicazione: Kangoo II



Code	Desc.
2930111861	11861

Misure mm: Ø 6,7  
Applicazione: Kangoo III



Code	Desc.
2930112052	12052

Misure mm: Ø 8,2  
Applicazione: portello Scenic III



Code	Desc.
2930112168	12168

Misure mm: Ø 8,2  
Applicazione: Tutti i tipi



Code	Desc.
2930112432	12432

Fixing M5x14 mudguard  
Application: all types



Code	Desc.
2930000428	428

**T=Ø 16 L=20 Foro Ø=9**  
Colore nero. Bottone fissaggio paraurti anteriore su traversa frontale Renault Twingo.



Code	Desc.
2930005765	5765

Applications: various on all Renault models



Code	Desc.
2930005635	5635

Applications: various on all Renault models

## Suzuki

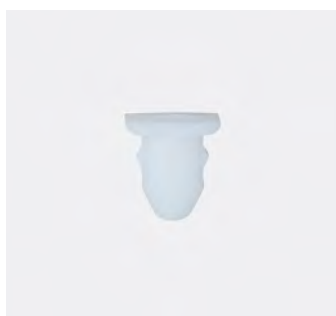

Code	Desc.
2930111781	11781

Applicazione: Tutti i tipi



Code	Desc.
2930111782	11782

Applicazione: Swift, Vitara



Code	Desc.
2930111783	11783

Applicazione: Tutti i tipi



Code	Desc.
2930111784	11784

Applicazione: Tutti i tipi



Code	Desc.
2930111785	11785

Applicazione: Tutti i tipi

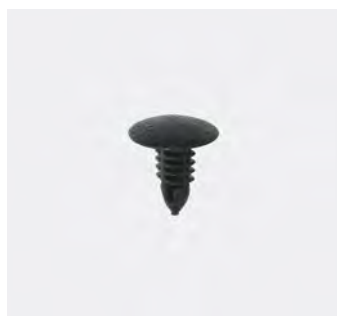

Code	Desc.
2930111786	11786

Applicazione: Tutti i tipi



Code	Desc.
2930111787	11787

Applicazione: Tutti i tipi

# Toyota



Code	Desc.
2930111762	11762

Applicazione: Tutti i tipi

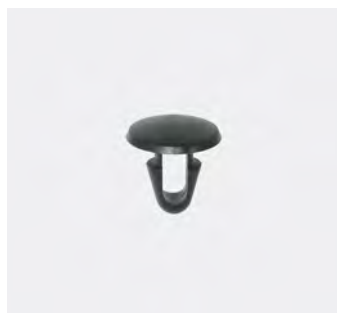

Code	Desc.
2930111765	11765

Applicazione: Tutti i tipi

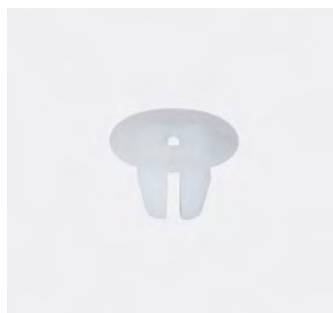

Code	Desc.
2930111766	11766

Applicazione: Tutti i tipi



Code	Desc.
2930111767	11767

Applicazione: Tutti i tipi



Code	Desc.
2930111769	11769

Applicazione: cofano Yaris, Corolla



Code	Desc.
2930111770	11770

Applicazione: Tutti i tipi

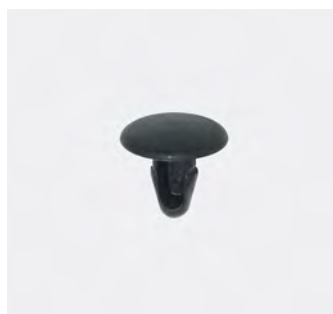

Code	Desc.
2930111771	11771

Applicazione: Tutti i tipi



Code	Desc.
2930111782	11782

Applicazione: Swift, Vitara



Code	Desc.
2930112381	12381

Applicazione: Tutti i tipi



Code	Desc.
2930112382	12382

Applicazione: Tutti i tipi



Code	Desc.
2930112383	12383

Applicazione: Tutti i tipi



Code	Desc.
2930112384	12384

Applicazione: Tutti i tipi



Code	Desc.
2930004420	4420

**T=Ø 18 Foro Ø=9**  
 Rivetto in plastica mascherina  
 radiatore Toyota Corolla. Colore nero.

## VW-Audi-Seat-Skoda



Code	Desc.
2930109920	9920

Misure mm:Ø 8  
 Applicazione: Volkswagen Tutti i tipi  
 Actea, Toledo



Code	Desc.
2930110262	10262

Misure mm:Ø 7,9 à 8,7  
 Applicazione: Golf III A3, A4, A6



Code	Desc.
2930110265	10265

Misure mm:7,4 x 7,4  
 Ø viti per lamiera mm: 4,8  
 Ø viti per materiali morbidi: 5  
 Applicazione: VW, Seat, Skoda tutti i tipi

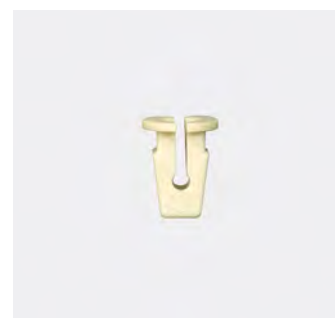

Code	Desc.
2930110289	10289

Misure mm:7 x 7  
 Ø viti per lamiera mm: 4,2  
 Applicazione: Polo 95, Golf III / IV  
 Sharan, Ibiza, Altea, Alhambra, Leon



Code	Desc.
2930110293	10293

Misure mm:8 x 8  
 Ø viti per lamiera mm: 4,8  
 Ø viti per i materiali morbidi: 5  
 Applicazione: Golf III



Code	Desc.
2930110298	10298

Misure mm:Ø 4,2  
 Applicazione: A3, A4



Code	Desc.
2930110303	10303

Misure mm:8,2 x 8,2  
 Ø viti per lamiera mm: 4,8  
 Ø viti per i materiali morbidi: 5  
 Applicazione: Golf IV Ibiza, Leon, Toledo  
 P { margin-bottom: 0.21cm;



Code	Desc.
2930110308	10308

Misure mm:5 x 15  
 Applicazione: VW, Seat, Skoda





Code	Desc.
2930110316	10316

Misure mm: 7,4 x 7,4  
 Ø viti per lamiera mm: 4,8  
 Ø viti per i materiali morbidi: 5  
 Applicazione: Golf IV, Passat 2000, A3, A4, A6



Code	Desc.
2930110391	10391

Misure mm: 7 x 7  
 Ø viti per lamiera mm: 4,8  
 Ø viti per i materiali morbidi: 5  
 Applicazione: Polo, Golf III, Passat 2000, A3, A4 2008

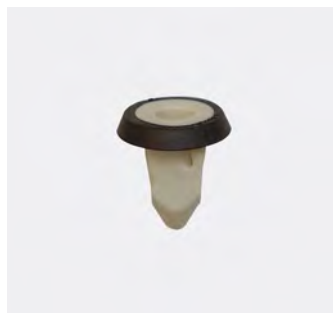

Code	Desc.
2930110630	10630

Misure mm: 8 x 8  
 Ø viti per lamiera mm: 4,8  
 Ø viti per i materiali morbidi: 5  
 Applicazione: VW, Seat, Skoda



Code	Desc.
2930110698	10698

Misure mm: 7,2 x 7,2  
 Ø viti per lamiera mm: 4,8  
 Ø viti per i materiali morbidi: 5  
 Applicazione: Polo 95, Golf IV, Golf V, Golf VI, Leon, Octavia II

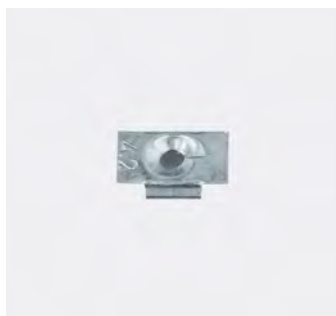

Code	Desc.
2930110870	10870

Misure mm: Ø 4,2  
 Applicazione: VW, Seat, Audi, Skoda



Code	Desc.
2930110991	10991

Misure mm: Ø 5  
 Applicazione: Twingo II, Scenic II



Code	Desc.
2930111125	11125

Misure mm: Ø 6 à 6,5  
 Applicazione: Twingo II, Scenic II

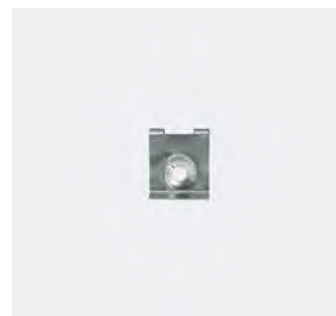

Code	Desc.
2930111168	11168

Misure mm: Ø 4,8  
 Applicazione: Polo, A3, A4 2005



Code	Desc.
2930111169	11169

Misure mm: Ø 4,8  
 Applicazione: VW, Seat, Audi, Skoda



Code	Desc.
2930111176	11176

Misure mm: Ø 4,8  
 Applicazione: VW, Seat, Audi, Skoda



Code	Desc.
2930111205	11205

Misure mm: Ø 4,6 à 4,8  
 Applicazione: VW, Audi, Seat, Skoda

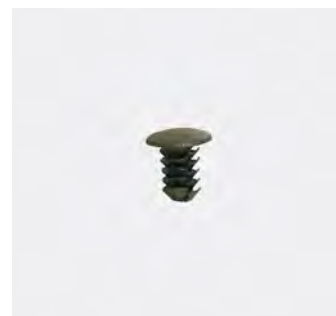

Code	Desc.
2930111345	11345

Misure mm: Ø 5  
 Applicazione: Fabia, Octavia, Ibiza, Cordoba



Code	Desc.
2930111480	11480

Misure mm: Ø 16  
Applicazione: Tutti i tipi



Code	Desc.
2930111493	11493

Applicazione: Audi A4, A6



Code	Desc.
2930111506	11506

Misure mm: Ø 5 à 5,5  
Applicazione: Audi A4, A6



Code	Desc.
2930111569	11569

Misure mm: Ø 6,5  
Applicazione: Seat Ibiza 2006, León II, Altea, Toledo 3



Code	Desc.
2930111960	11960

Misure mm: Ø 8  
Applicazione: Ibiza, UP, Mii Citigo

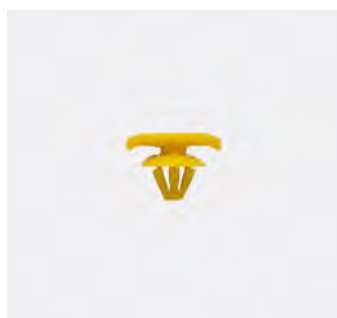

Code	Desc.
2930112064	12064

Misure mm: Ø 4,6  
Applicazione: Golf VI, Scirocco, Polo 2009



Code	Desc.
2930112329	12329

Misure mm: Ø 7,5  
Applicazione: tutti i tipi

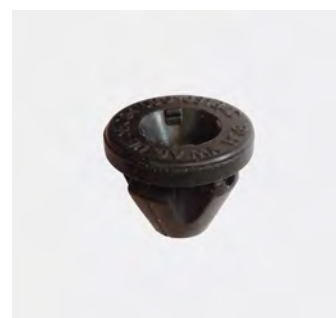

Code	Desc.
2930112440	12440

Applicazione: Motore 1,4 / 1,9 - 2,0 TDI



Code	Desc.
2930112734	12734

Misure mm: Ø 8,2  
Applicazione: Golf VII, Caddy, Amarok, A5 Sportback



Code	Desc.
2930112735	12735

Applicazione: Golf VII, Caddy, Amarok, A5 Sportback



Code	Desc.
2930111473	11473

Misure mm: Ø 6.8  
Applicazione: tutti i tipi



Code	Desc.
2930004660	4660

Ø=4,8x16  
Vite autofilettante/speciale varie applicazioni vari modelli Audi e VW, Testa 15.



Code	Desc.
2930000455	455

**T=Ø 18 hole Ø=7**  
 Black Colour. Rivet fastening interior trim Volkswagen Golf.



Code	Desc.
2930000119	119

Metal plate for housing fixing protection engine Volkswagen Golf 4.



Code	Desc.
2930004063	4063

**Ø 5,5 T 10**  
 Black Colour. Rivet wheel BMW series 3,5,7 D.5,5 T.10.



Code	Desc.
2930111953	11953

Measurements mm: d.7,5  
 Application: Fixing seals Skoda Fabia

## Peugeot-Citroën



Code	Desc.
2930110327	10327

Applicazione: 306, Partner, Berlingo



Code	Desc.
2930110465	10465

Applicazione: Guarnizioni carena tutti i tipi

## Renault-Dacia



Code	Desc.
2930100400	400

Spessore acciaio mm: 0,5 à 4  
Vite Ø mm: 6  
Dimensioni mm: 22,2x15  
Assegnazione: Peugeot, Citroën, Renault



Code	Desc.
2930111385	11385

Misure mm: 1/4 giro  
Assegnazione: Laguna III



Code	Desc.
2930111404	11404

Misure mm: 1/4 giro  
Assegnazione: Laguna III, Vel Satis, Espace IV



## VW-Audi-Seat-Skoda



Code	Desc.
2930111073	11073

Applicazioni: Passat 2000, A4, A6, Superb



Code	Desc.
2930111074	11074

Applicazioni: VW, Audi, Seat, Skoda



Code	Desc.
2930111076	11076

Applicazioni: Passat 2000, A4, A6, Superb



Code	Desc.
2930111077	11077

Applicazioni: Passat 2000, A4, A6, Superb



Code	Desc.
2930111133	11133

Applicazioni: Passat 2000, A4, A6, Superb



Code	Desc.
2930111134	11134

Applicazioni: A4, A6



Code	Desc.
2930111508	11508

Applicazioni: Passat 2000, A4, A6, Superb



Code	Desc.
2930111509	11509

Applicazioni: Audi

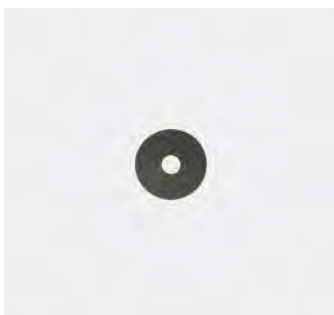

Code	Desc.
2930111510	11510

Applicazioni: Tutti i tipi

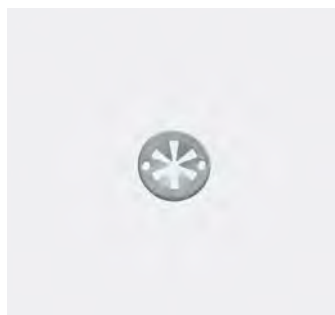

Code	Desc.
2930111550	11550

Applicazioni: Tutti i tipi

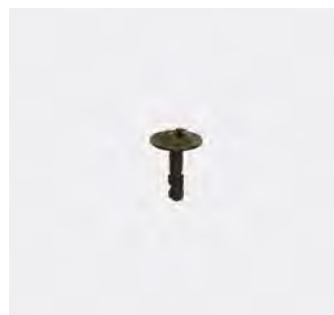

Code	Desc.
2930111963	11963

Applicazioni: Passat 2000, A4, A6, Superb



Code	Desc.
2930111964	11964

Applicazioni: Audi



Code	Desc.
2930112244	12244

Misure mm: Ø 7,9

Applicazioni: Sotto motore carena tutti i tipi

## Fiat-Alfa Romeo-Lancia



Code	Desc.
2930110203	10203

Applicazioni: Panda 2003, Punto I et II, Multipla, Doblo, 147, New Ypsilon, Lybra



Code	Desc.
2930112207	12207

Applicazioni: Panda II, Bravo, Multipla, Ducato III, 147, 159, GT, Ypsilon

## Peugeot-Citroën



Code	Desc.
2930101370	1370

Applicazioni: 106, 306, Saxo



Code	Desc.
2930111262	11262

Applicazioni: 308, 407, C4, C4 Picasso

## Renault



Code	Desc.
2930005775	5775

Applications: front dash guard  
Renault Traffic



**BMW-Mini**

Code	Desc.
2930101416	1416

Misure mm: Ø 6,7  
Applicazione: E34



Code	Desc.
2930101439	1439

Misure mm: Ø 9  
Applicazione: E36



Code	Desc.
2930101440	1440

Misure mm: Ø Ø 9  
Applicazione: E38, E39



Code	Desc.
2930101441	1441

Misure mm: Ø 8,2  
Applicazione: E30



Code	Desc.
2930110325	10325

Applicazione: E36 - si monta con il cod. 10326



Code	Desc.
2930110326	10326

Misure mm: Ø 9  
Applicazione: E36



Code	Desc.
2930112034	12034

Misure mm: Ø 7,8 a 8  
Applicazione: F01, F02, F07, F10, F11, F12, F13, E84



Code	Desc.
2930004580	4580

Staple fastening side sill kick plates Mini Cooper. White color.



Code	Desc.
2930004585	4585

Staple fastening side sill kick plates Mini Cooper. Black Colour.



Code	Desc.
2930005670	5670

Applications: sill and wheelhouse mouldingBmw X1 14-X3 16-

## Fiat-Alfa Romeo-Lancia



Code	Desc.
2930110160	10160

Misure mm: Ø 8,5  
Applicazione: Stilo, Mutipla, Doblo II, Delta, Ypsilon



Code	Desc.
2930110757	10757

Misure mm: Ø 8  
Applicazione: Fiat Ducato, Lancia Thesis, Fiorino, Qubo



Code	Desc.
2930112631	12631

Misure mm: Ø 8  
Applicazione: Panda III



Code	Desc.
2930112632	12632

Misure mm: Ø 8  
Applicazione: Panda III



Code	Desc.
2930005630	5630

Size 3.9x13 T12 torx PZ2  
Side windows, exterior moulding  
Giulia 16-stelvio 17- Door handle,  
side windows, exterior moulding 500l  
12-.500x 15- Exterior moulding  
moulding Ypsilon 11- Side windows,  
exterior moulding Jeep Renegade 14-



Code	Desc.
2930005755	5755

Applications: door panel Tipo15-Door  
panel Jeep Renegade 14-  
2930005760Light blue-coloured locking  
profileApplications: rear door Tipo 15-

## Ford



Code	Desc.
2930111324	11324

Misure mm: Ø 5  
Applicazione: Tutti i tipi

## Honda



Code	Desc.
2930111755	11755



Code	Desc.
2930111782	11782

Applicazione: Tutti i tipi

## Iveco



Code	Desc.
2930005770	5770

Applications: front dash fitting

## Jeep



Code	Desc.
2930005690	5690

Applicazioni: Renegade 14-



Code	Desc.
2930005660	5660

Applications: exterior moulding Renegade 14-

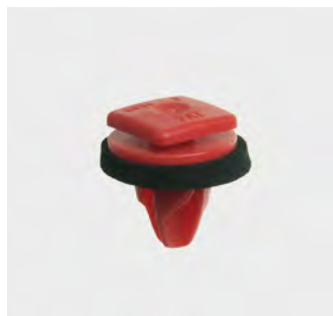

Code	Desc.
2930005665	5665

Applications : moulures externes Renegade 14-

## Mercedes-Smart

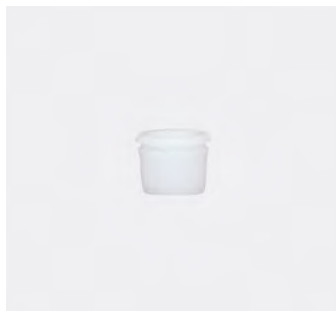

Code	Desc.
2930100390	390

Misure mm: Ø 9  
Applicazione: Tutti i tipi



Code	Desc.
2930112649	12649

Misure mm: 5,5 x 13  
Dimensioni mm: 21 x 43  
Applicazione: Classe C, CLK, E, ML, GL, S, Vito



Code	Desc.
2930112651	12651

Misure mm: Ø 9  
Dimensioni mm: 22 x 22,3  
Applicazione: Classe C/CLK

## Nissan



Code	Desc.
2930112547	12547

Misure mm: Ø 6  
Applicazione: Qashqai



Code	Desc.
2930112559	12559

Applicazione: Porte, portellone tutti i tipi



Code	Desc.
2930112573	12573

Applicazione: Porte, portellone tutti i tipi



Code	Desc.
2930112591	12591

Misure mm: Ø 8  
Applicazione: Qashqai



Code	Desc.
2930112592	12592

Misure mm: Ø 8  
Applicazione: Qashqai



Code	Desc.
2930112688	12688

Misure mm: Ø 8  
Applicazione: Tutti i tipi

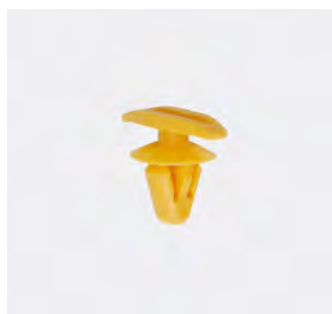

Code	Desc.
2930112854	12854

Measurements mm: d.5,2  
Application: all kindsP { margin-bottom: 0.21cm; }

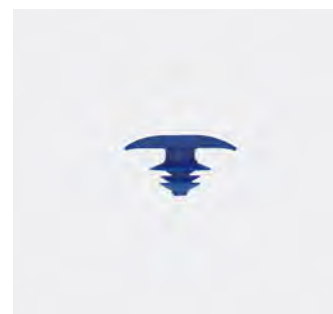

Code	Desc.
2930112855	12855

Measurements mm: d.5,2  
Application: all kinds





Code	Desc.
2930112857	12857

Measurements mm: d.7  
Application: all kinds



Code	Desc.
2930112866	12866

Measurements mm: d.5,2  
Application: all kinds



Code	Desc.
2930112841	12841

Measurements mm: d.8  
Application: Nissan, Range Rover

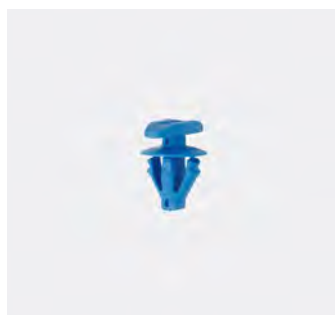

Code	Desc.
2930112845	12845

Measurements mm: d.5,2  
Application: all kindsP { margin-bottom: 0.21cm; }

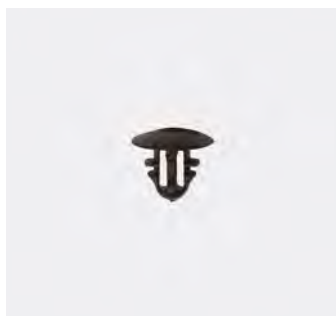

Code	Desc.
2930112848	12848

Measurements mm: d.5,2  
Application: Nissan,Skoda,Vw

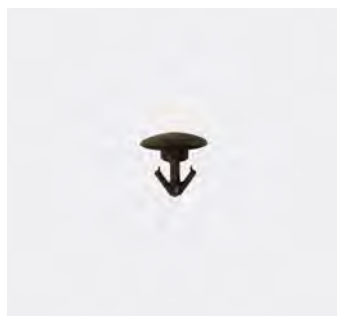

Code	Desc.
2930112851	12851

Measurements mm: d.4  
Application: Nissan



Code	Desc.
2930112532	12532

Measurements mm: d.4  
Application:Nissan Note,Hayon Juke,Leaf Patrol 370Z

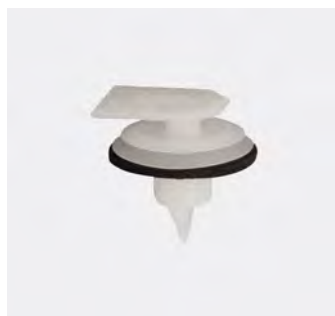

Code	Desc.
2930112566	12566

Measurements mm: d.8  
Application:Nissan Note,Hayon Juke



Code	Desc.
2930112827	12827

Application:Nissan Note E12,Qashqai

## Opel



Code	Desc.
2930111099	11099

Altezza mm: 11,1  
Applicazione: Astra G



Code	Desc.
2930111120	11120

Altezza mm: 7  
Applicazione: Astra G

## Peugeot-Citroën

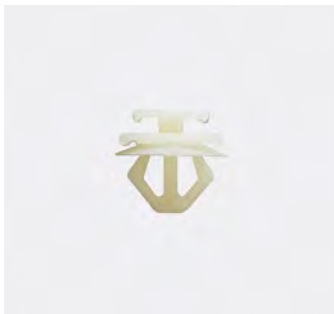

Code	Desc.
2930101301	1301

Misure mm: Ø 8,5  
Applicazione: Corpo modanatura laterale 106, 206, 306



Code	Desc.
2930101303	1303

Misure mm: Ø 9,5  
Applicazione: Corpo modanatura laterale cintura Saxo, Xsara, Xantia, Picasso, 407, C5, 206+, Berlingo, 307, Partner

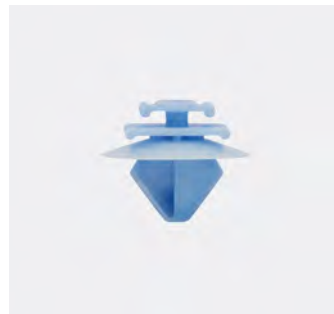

Code	Desc.
2930101492	1492

Misure mm: Ø 8,5  
Applicazione: Corpo modanatura laterale DS3, DS5



Code	Desc.
2930110160	10160

Misure mm: Ø 8,5  
Applicazione: modanatura laterale 206, 806 ph.2 Saxo, C2, Evasion II, 1007, 207, 308

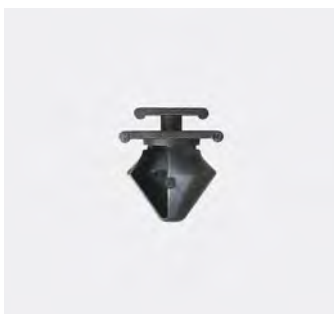

Code	Desc.
2930110237	10237

Misure mm: Ø 8  
Applicazione: Corpo modanatura laterale 406 ph.2 106



Code	Desc.
2930110757	10757

Misure mm: Ø 8  
Applicazione: Corpo modanatura laterale Boxer, Jumper, Bipper, Nemo



Code	Desc.
2930111267	11267

Misure mm: Ø 8,2  
Applicazione: 407, C4 Picasso, C6, 407 Coupé



Code	Desc.
2930111338	11338

Misure mm: Ø 8,2 a 8,5  
Applicazione: Portellone C4, Expert, Jumpy

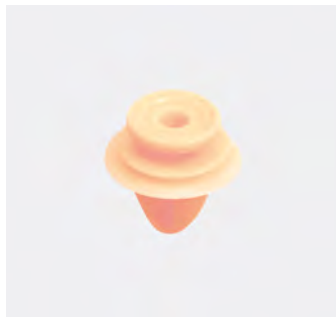

Code	Desc.
2930111650	11650

Misure mm: Ø 8,2  
Applicazione: Expert, 308, Jumpy



Code	Desc.
2930111802	11802

Misure mm: Ø 8,2  
Applicazione: 308



Code	Desc.
2930111828	11828

Misure mm: 8,2  
Applicazione: Modanatura naturale C4 Picasso, 207 CC



Code	Desc.
2930112877	12877

Measurements mm:d.8,2  
Application: Peugeot, Citroen



Code	Desc.
2930112882	12882

Measurements mm:d.8,2  
Application: door panels Citroen C4 Cactus-DS5, Peugeot 3008-5008



Code	Desc.
2930112890	12890

Measurements mm:d.8,2  
Application: Citroen C4 Cactus-Peugeot 2008



Code	Desc.
2930112816	12816

Measurements mm:d.5,2  
Application: Citroen C1, Peugeot 108, Toyota Aygo



Code	Desc.
2930112813	12813

Measurements mm:d.8,5  
Application: Citroen C1, Peugeot 108, Toyota Corolla, Kluger Highlander

## Renault-Dacia

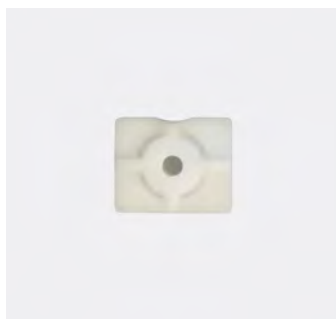

Code	Desc.
2930101292	1292

Misure mm: Ø 2,9  
Applicazione: Terminali Modanature laterali Clio II, R19, Kangoo, Megane, Scenic, Laguna



Code	Desc.
2930101293	1293

Misure mm: Ø 2,9  
Applicazione: Modanature laterali Megane et Scenic



Code	Desc.
2930101294	1294

Misure mm: Ø 2,9  
Applicazione: Modanature laterali Megane et Scenic



Code	Desc.
2930109978	9978

Misure mm: 6,2 x 12,2  
Applicazione: Kangoo, Master, Trafic

## Fixings exterior moldings

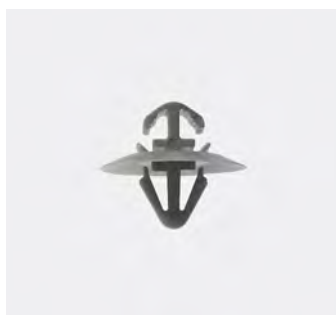

Code	Desc.
2930109979	9979

Misure mm: 6,2 x 12,2  
Applicazione: fasce laterali Kangoo, Master, Scenic 3, Trafic



Code	Desc.
2930109980	9980

Misure mm: 6,2 x 10,2  
Applicazione: Modanature laterali e modanature portellone posteriore - Kangoo

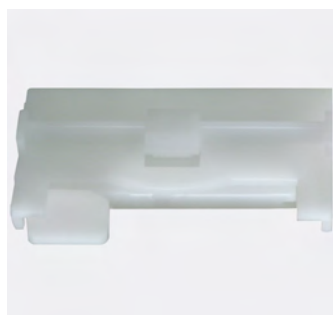

Code	Desc.
2930109992	9992

Applicazione: Modanature pannello del tetto - Kangoo



Code	Desc.
2930110036	10036

Misure mm: 6,2 x 12,2  
Applicazione: fasce laterali Master



Code	Desc.
2930110077	10077

Misure mm: 6,2 x 12,2  
Applicazione: Corpo modanature sottoporta Clio II, Kangoo, Megane, Vel Satis, Scenic 3



Code	Desc.
2930110100	10100

Misure mm: 6,2 x 12,2  
Applicazione: Modanature laterali Clio II, Laguna, Scenic 3, Kangoo ph2, Twingo, Modus



Code	Desc.
2930110109	10109

Misure mm: 6,2 x 12,2  
Applicazione: modanature portellone pannello porta Clio II, Megane break, Megane 3, Fluence

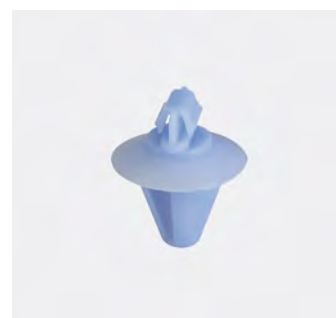

Code	Desc.
2930110110	10110

Misure mm: Ø 8,2 à 10  
Applicazione: modanature portellone Clio II

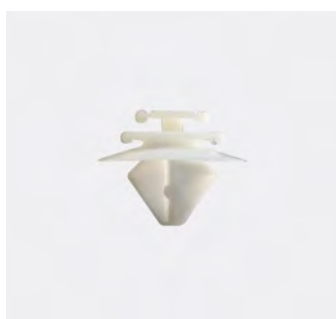

Code	Desc.
2930110160	10160

Misure mm: Ø 8,5  
Applicazione: Megane II



Code	Desc.
2930110370	10370

Misure mm: 8,2 x 16,2  
Applicazione: Corpo modanature laterali Espace 3, J6,6



Code	Desc.
2930110435	10435

Misure mm: Ø 8,2  
Applicazione: Dacia Logan

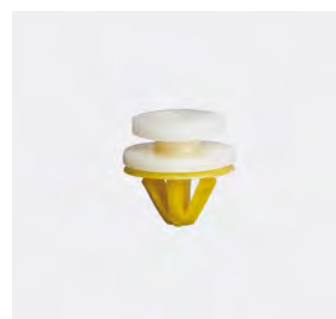

Code	Desc.
2930110448	10448

Misure mm: Ø 8,2  
Applicazione: Master, Trafic



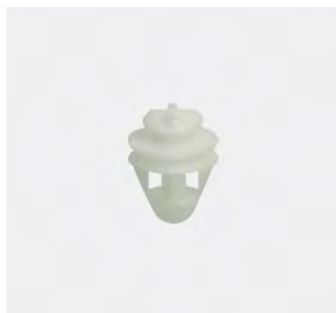

Code	Desc.
2930111435	11435

Misure mm: Ø 8 à 8,2  
Applicazione: Modanature clip Clio III, Twingo II



Code	Desc.
2930111637	11637

Applicazione: modanature laterali Express

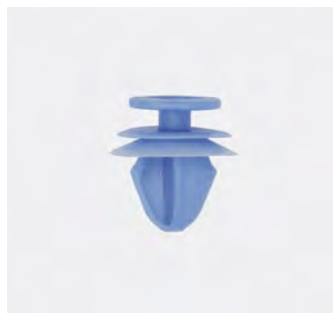

Code	Desc.
2930111811	11811

Misure mm: Ø 8,2  
Applicazione: Tutti i tipi

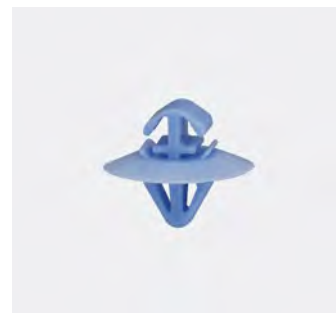

Code	Desc.
2930112700	12700

Misure mm: 6,2 x 12,2  
Applicazione: modanature laterali Trafic, Master, Kangoo

## VW-Audi-Seat-Skoda

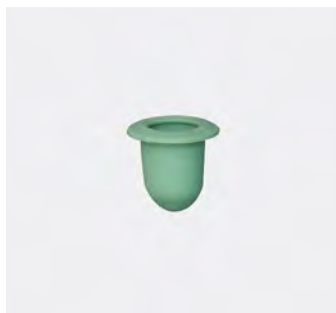

Code	Desc.
2930101408	1408

Misure mm: Ø 9  
Applicazione: Golf II et III, Passat



Code	Desc.
2930101487	1487

Misure mm: Ø 9  
Applicazione: Fabia II, Roomster



Code	Desc.
2930101488	1488

Misure mm: Ø 8,8  
Applicazione: Tiguan, Passat, Touareg, Scirocco, Sharan, Alhambra, Yeti



Code	Desc.
2930101490	1490

Misure mm: Ø 10  
Applicazione: Si monta con il cod. 1408 - Q3, Q5



Code	Desc.
2930110295	10295

Misure mm: Ø 6,4  
Applicazione: A3, A4



Code	Desc.
2930110629	10629

Misure mm: Ø 6,4  
Applicazione: Si monta con il cod. 1408 - Passat 200



Code	Desc.
2930112862	12862

Measurements mm:d.6,2  
Application:Seat Toledo,Skoda Rapid

## Fiat



Code	Desc.
2930000008	8

**Ø=6x16**  
 Black galvanizing. Key T30. Screw fixing bumper - Fiat Marea, Seicento, New Punto, Multipla, Palio, Lybra.

## Ford



Code	Desc.
2930004076	4076

**Ø 4,8x14 T 16**  
 Black Colour. Rivet bumper Ford Ka D. 4,8x14 T.16

## Honda



Code	Desc.
2930111753	11753

Applicazione: paraurti Accord



Code	Desc.
2930004340	4340

**T=Ø 20 hole Ø=8**  
Plastic rivet various applications various models Honda, Mitsubishi, Nissan. Color nero.Vite 6.30



Code	Desc.
2930004350	4350

**T=Ø 20. Ø=6x16**  
Button fastener coatings and guards Honda models. Black Colour.



Code	Desc.
2930004320	4320

**T=Ø 20 hole Ø=10**  
Rivet plastic bumper various Honda models. Black Colour.

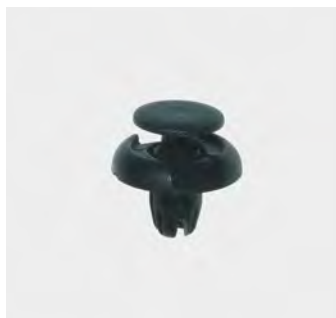

Code	Desc.
2930004315	4315

**T=Ø 20 hole Ø=8**  
Rivet plastic locari wheel arches Honda Civic, HRV, CRV, Jazz. Black Colour.

## Mercedes-Smart



Code	Desc.
2930112671	12761

Applicazione: paraurti Accord

## Nissan

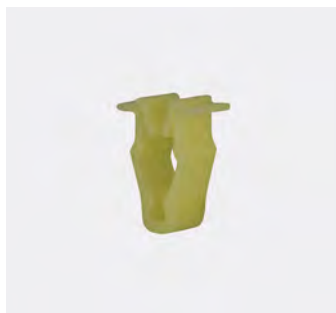

Code	Desc.
2930101493	1493

Applicazione: protezione Parafango Qashqai



Code	Desc.
2930111776	11776

Applicazione: Paraurti, assetto ruote Micra, Pajero



Code	Desc.
2930111777	11777

Applicazione: Paraurti - Tutti i tipi

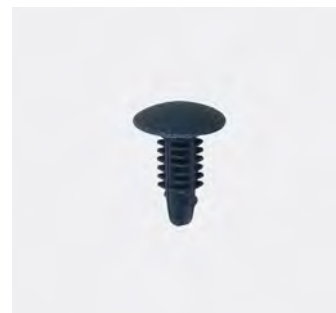

Code	Desc.
2930111779	11779

Applicazione: Supporto Paraurti Micra

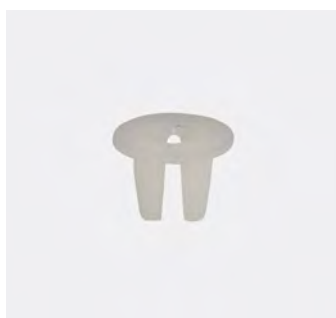

Code	Desc.
2930112588	12588

Misure mm: Ø 10 x 10  
 Ø vite mm: Ø 6  
 Applicazione: paraurti anteriore Juke, Qashqai



Code	Desc.
2930101498	1498

Measurements mm:d.7  
 Application:Nissan Quashqai

## Opel - Chevrolet

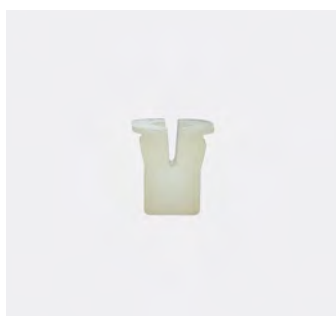

Code	Desc.
2930110331	10331

Misure mm:8,2 x 8,2  
 Ø vite mm: 4,2 mm  
 Applicazione: Aile, bouclier, Corsa B et C, Combo

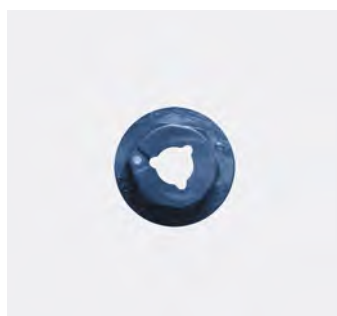

Code	Desc.
2930110362	10362

Applicazione: Ala, paraurti, Astra F Vectra B



Code	Desc.
2930110363	10363

Applicazione: Ala, paraurti, Corsa B et C Combo, Zafira

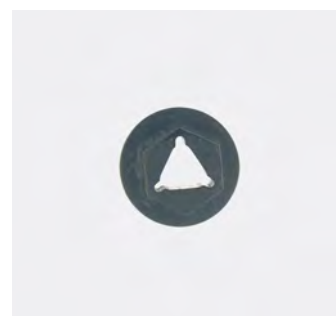

Code	Desc.
2930111004	11004

Applicazione: Ala, paraurti, tutti i tipi



## Peugeot-Citroën



Code	Desc.
2930100372	372

Dimensioni mm: 6 x 16  
Applicazioni: Viti a metallo con base seghettata - Testa H - Peugeot, R21



Code	Desc.
2930109647	9647

Applicazioni: Paraurti 306, 806, Partner, Berlingo, Evasion



Code	Desc.
2930111773	11773

Misure mm: Ø 8  
Applicazioni: rivestimento interno paraurti 107, C1



Code	Desc.
2930112774	12774

Misure mm: 8 x 15  
Applicazioni: Paraurti C3 Picasso

## Renault

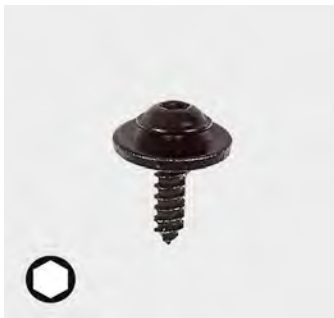

Code	Desc.
2930000976	976

Ø 4,2x13  
Black galvanizing.  
Screw fixing shelter wheel compartment (with captive washer) Renault Twingo, Laguna, Nevada, Safrane.

## Toyota



Code	Desc.
2930004450	4450

**T=Ø 18 hole Ø=7,5**  
Rivet plastic locari wheel arches Toyota Land Cruiser, Lexus LX470, RAV 4. Black color.



Code	Desc.
2930004425	4425

**T=Ø 18 hole Ø=7**  
Rivet plastic locari wheel arches Toyota Corolla, Yaris. Black Colour.



Code	Desc.
2930004430	4430

Fixing molding bumper Toyota Rav4. White color.

## BMW-Mini



↗ 50%

Code	Desc.
2930112049	12049

Applicazioni: Parabrezza E32, E34



Code	Desc.
2930112035	12035

Applicazione: Parabrezza R50, R52, R53



Code	Desc.
2930112036	12036

Applicazione: Parabrezza R50, R52, R53



Code	Desc.
2930112037	12037

Applicazione: Parabrezza R50, R52, R53

## Fiat



Code	Desc.
2930003029	3029

### Per tubi Ø 4

Con valvola. Raccordi tubi per impianto lavacrystallo Fiat Panda, Tipo, Tempra, Cinquecento, Punto, Marea, Bravo, Brava, Seicento, Coupé, Alfa Romeo 145, 146 Lancia Delta, Prisma, Y, Nuova Delta, Dedra.



Code	Desc.
2930003044	3044

### Per tubi Ø 4

Raccordo tubi per impianto lavacrystallo Fiat Cinquecento, Panda, Punto, Tipo, Tempra, Croma, Ducato.



Code	Desc.
2930003051	3051

### Per tubi Ø 4

Raccordo tubi per impianto lavacrystallo Fiat Uno, Punto.

## Ford



Code	Desc.
2930112236	12236

Applicazioni: Parabrezza Fiesta 2009

## Opel



Code	Desc.
2930112016	12016

Applicazioni: Parabrezza Astra G



Code	Desc.
2930112017	12017

Applicazioni: Parabrezza Astra G

## Peugeot-Citroën



Code	Desc.
2930110909	10909

Applicazioni: Parabrezza C2, 407



Code	Desc.
2930111383	11383

Applicazioni: Parabrezza 308, 508, C5/X7

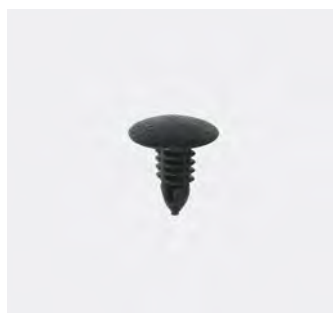

Code	Desc.
2930111786	11786

Misure mm: Ø 5  
Applicazioni: Parabrezza 4007, C-Crosser



Code	Desc.
2930111983	11983

Applicazioni: Parabrezza 508, C5/X7

## Fixing for windscreen



Code	Desc.
2930112029	12029

Applicazioni: Scuttle griglia Berlingo, Partner



↗ 50%

Code	Desc.
2930112100	12100

Applicazioni: parabrezza 3008, 5008, C4/B7, DS5



Code	Desc.
2930112155	12155

Applicazioni: parabrezza C3 Picasso

## Renault-Dacia



Code	Desc.
2930111079	11079

Applicazioni: Parabrezza apertura Clio III, Modus, Zoé



↗ 50%

Code	Desc.
2930111085	11085

Applicazioni: Modanature pannello del tetto Modus



Code	Desc.
2930111327	11327

Misure mm: Ø 8,2  
Applicazioni: Megane CC

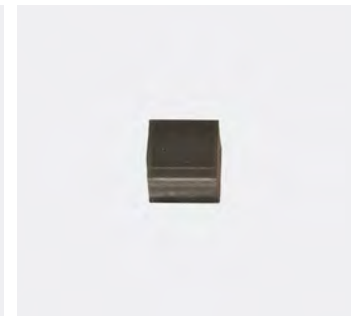

Code	Desc.
2930111334	11334

Applicazioni: Clio III, Modus Adesivo



Code	Desc.
2930111370	11370

Applicazioni: Modus



Code	Desc.
2930111434	11434

Applicazioni: Modanature pannello del tetto Clio III



↗ 50%

Code	Desc.
2930111457	11457

Applicazioni: parabrezza Clio III, Symbol



Code	Desc.
2930111672	11672

Applicazioni: Modanature pannello del tetto Twingo, Wind





Code	Desc.
2930111697	11697

Misure mm: Ø 6,8  
Applicazioni: Laguna III



Code	Desc.
2930111966	11966

Misure mm: Ø 8,2  
Applicazioni: Scenic III



Code	Desc.
2930111988	11988

Misure mm: Ø 6,2  
Applicazioni: Fluence, Megane III



Code	Desc.
2930112014	12014

Misure mm: Ø 8,2  
Applicazioni: Scenic III



Code	Desc.
2930112052	12052

Misure mm: Ø 8,2  
Applicazioni: Clio III



Code	Desc.
2930112074	12074

Applicazioni: Modanature pannello del tetto Megane III, Scenic III



Code	Desc.
2930112212	12212

Applicazioni: Adesivo tutti i modelli

## VW-Audi-Seat-Skoda



Code	Desc.
2930110666	10666

Applicazioni: parabrezza Golf III



Code	Desc.
2930112352	12352

Misure mm: 3,2 x 6  
Applicazioni: parabrezza Audi, Volkswagen, Seat, Skoda



Code	Desc.
2930112356	12356

Applicazioni: parabrezza Touran

## BMW-Mini



Code	Desc.
2930112665	12665

Ø Vite prigioniera mm: Ø 5  
Applicazioni: Tutti i generi



Code	Desc.
2930112666	12666

Ø Vite prigioniera mm: Ø 5  
Applicazioni: Série 1, 3, X1, X3, Z4, Mini Countryman, Paceman



Code	Desc.
2930112667	12667

Ø Vite prigioniera mm: Ø 5  
Applicazioni: BMW Tous types



Code	Desc.
2930004595	4595

**T=Ø 20 L= 18 X Ø=5,8**  
Rivetto in plastica locari passaruota BMW X3,X5. Colore nero.

## Fiat,Alfa Romeo



Code	Desc.
2930005695	5695

Rivetto riutilizzabile x foro d.7mm Testa d.20mm  
Applicazioni:Giulia 16-Stelvio 17-



Code	Desc.
2930005750	5750

Black button for square hole m5-head T18mm  
Applications: door compartment guards Giulia 16-Stelvio 17-

## Mercedes-Smart



Code	Desc.
2930112667	12667

Misure mm: vite prigioniera M5  
Applicazioni: tutti i tipi



Code	Desc.
2930004545	4545

**T=Ø 16, F= 6,5 L= 14.**

Rivetto in plastica locari  
passaruota Mercedes C 200. Colore nero.

## Nissan



↗ 50%

Code	Desc.
2930112596	12596

Applicazioni: tutti i tipi

## Renault-Dacia



Code	Desc.
2930101233	1233

Misure mm: Ø 10,2  
Applicazioni: Insonorizzazione Ampia  
testa: 35 mm - passaruota Tutti I Tipi



Code	Desc.
2930101358	1358

Misure mm: 6,2 x 12,2  
Applicazioni: Parafanghi Megane, Scenic,  
Lagunai



Code	Desc.
2930110082	10082

Misure mm: Ø 10,2 à 10,7  
Applicazioni: Insonorizzazione Ampia  
testa: 35 mm - passaruota Tutti I Tipi



Code	Desc.
2930111889	11889

Misure mm: 8 x 20  
Applicazioni: Laguna III, Megane III

## Toyota

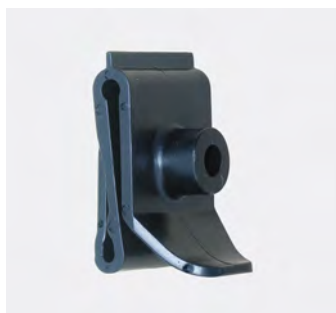

Code	Desc.
2930111764	11764

Applicazioni: Modanature passaruota  
Carina, Celica, Corolla, Previa

## VW-Audi-Seat-Skoda



Code	Desc.
2930111356	11356

Misure mm: vite prigioniera 5 x 14  
Applicazioni: tutti i tipi



Code	Desc.
2930112334	12334

Misure mm: Ø 0,7 à 3  
Applicazioni: Audi A1



## BMW-Mini



Code	Desc.
2930111473	11473

Misure mm: Ø 6.8  
 Ø vite o bullone mm: Ø 5  
 Applicazione: Tutti i tipi BMW

## Fiat-Alfa Romeo-Lancia



Code	Desc.
2930005655	5655

Bottone nero x foro 10mm testa 18mm  
 Applicazioni: rivestimenti interni, vano  
 vagagliaio Idea 02-12- Panda 12-Musa  
 04-12-



Code	Desc.
2930005615	5615

Plastic nut  
 Applications: Fiat car interiors Doblò 00-



Code	Desc.
2930005650	5650

Multigrip aluminium rivet  
 Size 4.8x11 TL  
 16 mm  
 Applications: interiors, guards,  
 rear light fitting 500 12-.500L 12-Panda  
 12-Tipo 15- 500 Abarth 12-

## Nissan



Code	Desc.
2930112380	12380

Applicazione: tutti i tipi

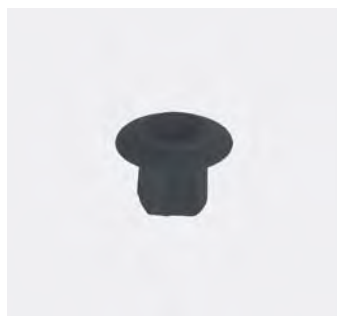

Code	Desc.
2930112538	12538

Misure mm: Ø 10  
Applicazione: tutti i tipi



Code	Desc.
2930112691	12691

Misure mm: 8 x 12  
Applicazione: Juke



Code	Desc.
2930112743	12743

Misure mm: 8 x 12  
Applicazione: tutti i tipi



Code	Desc.
2930112744	12744

Misure mm: 8 x 12  
Applicazione: tutti i tipi

## Peugeot-Citroën

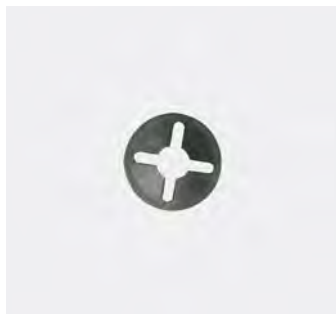

Code	Desc.
2930100559	559

Ø gambo mm: 8 x 12  
Applicazione: C3



Code	Desc.
2930110680	10680

Ø asse mm: 5  
Applicazione: C3, C4, C5, 407

Peugeot-Citroën



Code	Desc.
2930110753	10753

Applicazione: 207, 508, DS3, C3 Picasso



Code	Desc.
2930110754	10754

Applicazione: 207, C3, DS3, C3 Picas



Code	Desc.
2930112154	12154

Applicazione: 207, C3, C3 Picasso



Code	Desc.
2930112157	12157

Applicazione: 207, DS3, C3 Picasso



## BMW-Mini



Code	Desc.
2930112652	12652

Applicazione: Serie 1, 3, 6, X1, X6  
Si monta con il cod. 12653



Code	Desc.
2930112653	12653

Misure mm: Ø 11  
Applicazione: Série 1, 3, 6, X1, X6

## Ford



Code	Desc.
2930112405	12405

Misure mm: Ø 9  
Applicazioni: Focus 2011



Code	Desc.
2930112417	12417

Misure mm: Ø 9  
Applicazioni: C-max 2010, B-Max 2012

## Nissan

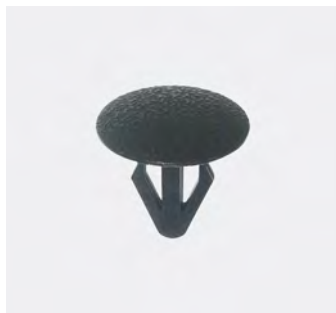

Code	Desc.
2930111774	11774

Applicazione: Tappeti - tutti i tipi

## Peugeot-Citroën



Code	Desc.
2930100424	424

Misure mm: Ø 10,5  
 Applicazione: Pulsante di fissaggio tappeto bagagliaio Peugeot, Citroën tutti i tipi. si monta con il cod. 425



Code	Desc.
2930101111	1111

Misure mm: Ø 7,2  
 Applicazione: Pulsante di fissaggio tappetini 106, 205, 306, 309, 405 Vecchi modelli



Code	Desc.
2930101484	1484

Applicazione: Tutti i tipi



Code	Desc.
2930110596	10596

Applicazione: Tutti i tipi



Code	Desc.
2930100425	425

Misure mm: Ø 10,5  
 Applicazioni: Si monta con il cod.424



Code	Desc.
2930000260	260

Colore bianco (con guarnizione in gomma). Bottone fermapannello e rivestimenti interni Peugeot.

## Renault-Dacia



Code	Desc.
2930101232	1232

Applicazione: vite prigioniera -  
insonorizzazione tappetini tutti i tipi

## VW-Audi-Seat-Skoda



Code	Desc.
2930112672	12672

Misure mm: Ø 8,2  
Applicazione: volante inferiore Exeo

## BMW-Mini



Code	Desc.
2930109611	9611

Misure mm: Ø 8  
Applicazione: tutti i tipi



Code	Desc.
2930111152	11152

Misure mm: Ø 8  
Applicazione: tutti i tipi



Code	Desc.
2930112135	12135

Misure mm: Ø 8  
Applicazione: E70/71, E89, R60



Code	Desc.
2930112159	12159

Misure mm: Ø 8,3  
Applicazione: R50, R52, R53, R56



Code	Desc.
2930112160	12160

Misure mm: Ø 8  
Applicazione: Serie 1 tutti i tipi , E46 compact, R55, R56, R57

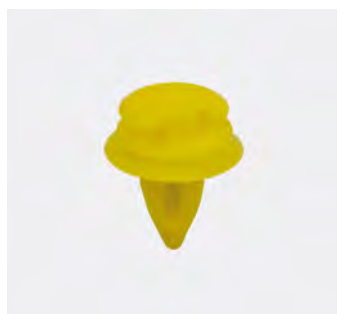

Code	Desc.
2930112162	12162

Misure mm: Ø 8  
Applicazione: E39, E52, E85, E86, E89



Code	Desc.
2930112654	12654

Misure mm: Ø 8  
Applicazione: BMW T tutti i tipi 1998> Mini Tutti i tipi



Code	Desc.
2930112659	12659

Misure mm: Ø 8  
Applicazione: Serie 3 E36, E46, Serie 5 E34, E39, Série 5 E53, E70



Code	Desc.
2930112661	12661

Misure mm: Ø 8  
Applicazione: X1, Mini Clubman



Code	Desc.
2930112662	12662

Misure mm: Ø 8  
Applicazione: Serie 5 GT, Serie 7, Serie 6 F13, Z4



Code	Desc.
2930112663	12663

Misure mm: Ø 8  
Applicazione: Z4, Mini Clubman



Code	Desc.
2930112664	12664

Misure mm: Ø 8  
Applicazione: Serie 1 E88, Serie 3 E36, E46, E9..., Serie 5 E6..., Serie 6 E6... F25, Mini Cabrio



Code	Desc.
2930112675	12675

Misure mm: Ø 8  
 Applicazione: Serie 1, 3, X3, Z

## Chrysler



Code	Desc.
2930112818	12818

Misure mm: Ø 8,5  
 Applicazione: Freemont, Thema, Flavia, Voyager

## Fiat-Alfa Romeo-Lancia



Code	Desc.
2930101338	1338

Misure mm: Ø 8,2 à 8,5  
 Applicazione: Portellone C4 Expert, Jumpy



Code	Desc.
2930101339	1339

Applicazione: Fiat tutti i tipi, Alfa 156, 159, 166, Ypsilon  
 Si monta con il cod. 1340 o 10383 o 10488

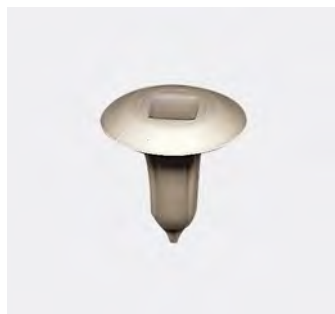

Code	Desc.
2930101340	1340

Misure mm: 8 x 8  
 Applicazione: Fiat Seicento, Panda, Punto, Stilo, Lancia Ypsilon, Lybra, Multipla, Qubo



Code	Desc.
2930101341	1341

Misure mm: 8 x 8  
 Applicazione: Fiat Tutti i tipi, Alfa 147, 156, 166, Lancia Y, Lybra



## Fixing for car doors



Code	Desc.
2930101354	1354

Misure mm: Ø 8  
Applicazione: Fiat Punto, Stilo, Marea, Bravo, Brava, Lybra



Code	Desc.
2930101403	1403

Misure mm: Ø 6 à 6,2  
Applicazione: tutti i tipi

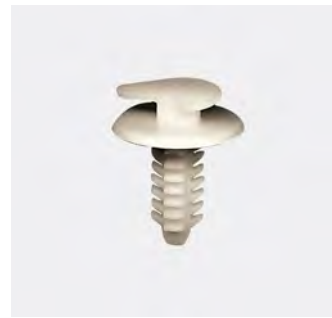

Code	Desc.
2930101404	1404

Applicazione: Fiat Bravo, Brava, Marea, Ducato  
Si monta con il cod. 1338



Code	Desc.
2930109833	9833

Misure mm: Ø 6  
Applicazione: tutti i tipi



Code	Desc.
2930109957	9957

Misure mm: Ø 6,5 à 6,7  
Applicazione: Fiat Panda



Code	Desc.
2930110202	10202

Applicazione mm: Fiat Seicento, 500, Panda 2004, Multipla, Lancia Lybra, Fiorino, Qubo  
si monta con il cod. 1340 o 10383 o 10488

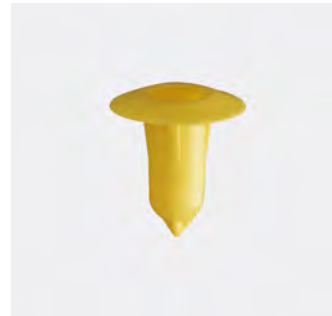

Code	Desc.
2930110383	10383

Misure mm: Ø 8,2  
Applicazione: Fiat Panda, 500, Punto, Idea, Stilo, Alfa 166, Lancia Musa, Ypsilon, Ducato



Code	Desc.
2930110389	10389

Misure mm: 8x8  
Applicazione: Fiat Punto, Lancia Ypsilon, Ducato



Code	Desc.
2930110476	10476

Misure mm: Ø 6,2  
Applicazione: Fiat Punto, 500, Idea, Stilo, Doblo, Alfa 147, 156, Lancia Lybra, Ypsilon, Fiorino

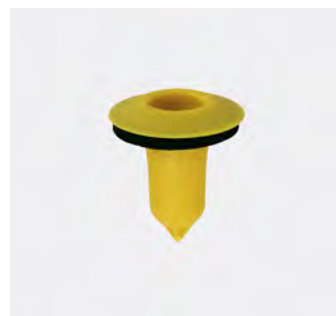

Code	Desc.
2930110488	10488

Misure mm: Ø 8,2  
Applicazione: Alfa 147, 156, 159, Fiorino



Code	Desc.
2930110790	10790

Misure mm: Ø 8,2  
Applicazione: Fiat Ulysse, Scudo

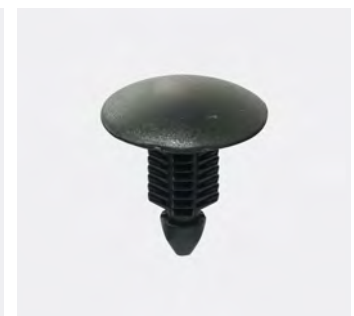

Code	Desc.
2930111730	11730

Misure mm: Ø 8 a 9  
Applicazione: Tutti i tipi



Code	Desc.
2930111790	11790

Misure mm: Ø 8  
Applicazione: Grande Punto



Code	Desc.
2930111795	11795

Misure mm: Ø 8  
Applicazione: Bravo II, Idea, Musa, Grande Punto, Panda, Qubo, Mito, Giuletta, Doblo II  
With gasket

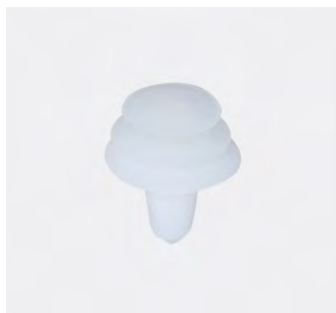

Code	Desc.
2930111845	11845

Misure mm: Ø 8  
Applicazione: Bravo II



Code	Desc.
2930111875	11875

Misure mm: Ø 6,5  
Applicazione: Fiat 500



Code	Desc.
2930111892	11892

Misure mm: Ø 8  
Applicazione: Tutti i tipi



Code	Desc.
2930112633	12633

Misure mm: Ø 8  
Applicazione: Panda III, 500L



Code	Desc.
2930112216	12216

Misure: Ø 8,5  
Applicazione: Panda III, 500L, New Ypsilon



Code	Desc.
2930112630	12630

Applicazione: Panda III, 500L, New Ypsilon



Code	Desc.
2930112911	12911

Application: Fiat 500X-Jeep Renegade



Code	Desc.
2930112913	12913

Measurements mm: d:8  
Application: Fiat 500X-Jeep Renegade



Code	Desc.
2930000241	241

Light blue. Button stops the door panel  
Fiat Uno, Alfa 75.155, 164.



Code	Desc.
2930005595	5595

L= 29 T=Ø 25 Ø hole=8  
Dark beige. Button liners Alfa Romeo 159.



Code	Desc.
2930005760	5760

Light blue-coloured locking profile  
Applications: rear door Tipo 15-

## Ford



Code	Desc.
2930101337	1337

Misure mm: Ø 8,2  
Applicazione: Fiesta, Escort



Code	Desc.
2930110347	10347

Misure mm: Ø 8 a 8,2  
Applicazione: Focus, Galaxy



Code	Desc.
2930110523	10523

Misure mm: Ø 6,5  
Applicazione: Focus



Code	Desc.
2930110524	10524

Misure mm: Ø 6,5  
Applicazione: Focus, Mondeo 97



Code	Desc.
2930110790	10790

Misure mm: Ø 8,2  
Applicazione: Fiesta, C-Max



Code	Desc.
2930111264	11264

Misure mm: Ø 8,2  
Applicazione: Focus, C-Max



Code	Desc.
2930111892	11892

Misure mm: Ø 8  
Applicazione: Ka 2009



Code	Desc.
2930112161	12161

Misure mm: Ø 6  
Applicazione: Fiesta 2009



Code	Desc.
2930112403	12403



Code	Desc.
2930112578	12758

Misure mm: Ø 9,1  
Applicazione: Focus 2011, Ranger 2012

Measurements mm:d.8,5  
Application:Ford Transit Custom

## Mercedes-Smart



Code	Desc.
2930101337	1337

Misure mm: Ø 8,2  
Applicazione: W210



Code	Desc.
2930110692	10692

Misure mm: Ø 8  
Applicazione: W168



Code	Desc.
2930110777	10777

Misure mm: Ø 8,2  
Applicazione: Smart For Four



Code	Desc.
2930111851	11851

Misure mm: Ø 10,2  
Applicazione: W245



Code	Desc.
2930112437	12437

Misure mm: Ø 8,6  
Applicazione: Tutti i tipi



Code	Desc.
2930112438	12438

Misure mm: Ø 8,2  
Applicazione: Tutti i tipi



Code	Desc.
2930112445	12445

Misure mm: Ø 8,2  
Applicazione: Tutti i tipi



Code	Desc.
2930112660	12660

Misure mm: Ø 8  
Applicazione: Classe C, E, Sprinter



Code	Desc.
2930112668	12668

Misure mm: Ø 8,2  
Applicazione: Classe A, B, C, CLS, E, ML, GL, SLR



Code	Desc.
2930112670	12670

Misure mm: Ø 8  
Applicazione: Classe A, B



Code	Desc.
2930112672	12672

Misure mm: Ø 8,2  
Applicazione: Vito, Sprinter

## Nissan

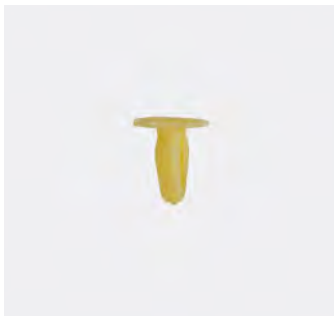

Code	Desc.
2930112608	12608

Measurements mm:d.5,2  
Application: All models



Code	Desc.
2930112773	12773

Measurements mm:d.5,2  
Application: All models



Code	Desc.
2930112579	12579

Measurements mm:d.5,2  
Application:Juke,X trail



Code	Desc.
2930112572	12572

Measurements mm:d.6,2  
Application:Juke,Note



Code	Desc.
2930112569	12569

Measurements mm:d.8  
Application:Juke,Note370Z-X-Trail



## Opel - Chevrolet



Code	Desc.
2930110333	10333

Misure mm: Ø 8 a 8,2  
Applicazione: Corsa B e C, Combo, Astra F et G, Zafira, Vectra A, B e C

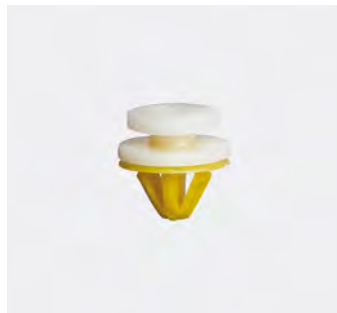

Code	Desc.
2930110448	10448

Misure mm: Ø 8,2  
Applicazione: Vivaro, Movano



Code	Desc.
2930111016	11016

Misure mm: Ø 8 a 8,2  
Applicazione: Astra F, Vectra C



Code	Desc.
2930111889	11889

Misure mm: 8,0 x 20  
Applicazione: Corsa C, D, Meriva, Astra H, Zafira B, Signum, Insignia



Code	Desc.
2930112441	12441

Applicazione: Astra J, Insignia, Zafira C, Meriva B, Aveo 2012, Cruze 2010, Orlando 2011



Code	Desc.
2930112442	12442

Applicazione: Astra J, Insignia, Zafira C, Meriva B, Aveo 2012, Cruze 2010, Orlando 2011



Code	Desc.
2930112443	12443

Misure mm: Ø 7,4  
Applicazione: Astra H

## Peugeot-Citroën



Code	Desc.
2930100132	132

Misure mm: Ø 8  
Applicazione: Collare di tenuta



Code	Desc.
2930100340	340

Misure mm: Ø 8  
Applicazione: 106, 205, 306, 309, 405, 406, 605, 806 AX, BX, Evasion, C15



Code	Desc.
2930101330	1330

Misure mm: Ø 8  
Applicazione: 106 ph.2, 405, 806

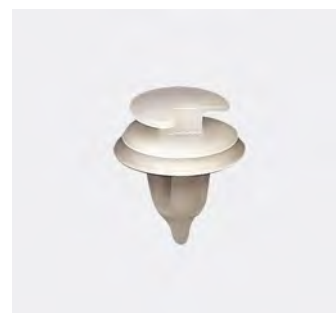

Code	Desc.
2930101331	1331

Misure mm: Ø 8,2  
Applicazione: 406

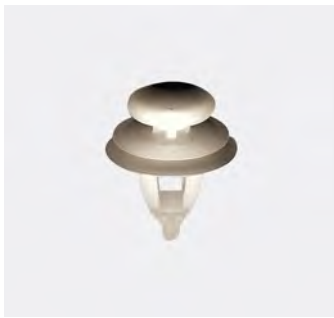

Code	Desc.
2930101332	1332

Misure mm: Ø 8,2  
Applicazione: Partner, Saxo, Xsara, Xsara Picasso, Berlingo



Code	Desc.
2930109931	9931

Misure mm: Ø 8,2  
Applicazione: 206, 306 ph.2 C4 Picasso



Code	Desc.
2930110435	10435

Misure mm: Ø 8,2  
Applicazione: 206, 207, 307, 407, 607, C2, C3, C4, Xsara II, C5, 1007, 308, C4 Picasso



Code	Desc.
2930110455	10455

Misure mm: Ø 8,2  
Applicazione: portellone 307, 607, C4 Picasso



Code	Desc.
2930110790	10790

Misure mm: Ø 8,2  
Applicazione: 407, 807, C8, 1007, Expert, Jumpy, C3, DS3, B9



Code	Desc.
2930111638	11638

Misure mm: Ø 8,2  
Applicazione: 508, 308 T9, Picasso B78, 301, C4 Elysée



Code	Desc.
2930111650	11650

Misure mm: Ø 8,2  
Applicazione: Expert III, Jumpy III, Scudo III



Code	Desc.
2930111762	11762

Misure mm: Ø 8,5  
Applicazione: 107, 4007, 4008, C1, C-Crosser, C4 Aircross

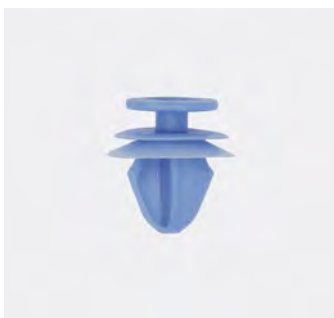

Code	Desc.
2930111811	11811

Misure mm: Ø 8,2  
Applicazione: 07, 3008, 5008, C3 II, DS3, Berlingo B9

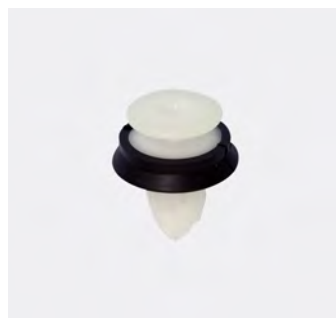

Code	Desc.
2930111973	11973

Misure mm: Ø 8,4  
Applicazione: C5/X7



Code	Desc.
2930112030	12030

Misure mm: Ø 8,5  
Applicazione: B9



Code	Desc.
2930112813	12813

Measurements mm:d.8,5mm  
Application: Citroen C1, Peugeot 108, Toyota Corolla-Kluger Highlander



Code	Desc.
2930112815	12815

Measurements mm:d.8,2  
Application :Peugeot 308T-92



Code	Desc.
2930112812	12812

Measurements mm:d.5,2  
Application :Citroen C1-Peugeot 108-  
Toyota Aygo



Code	Desc.
2930112806	12806

Measurements mm:d.5,2  
Application :Citroen C4 Picasso,C-Elisee-  
Peugeot 308



Code	Desc.
2930112778	12778

Measurements mm:d.8,2  
Application :Citroen C4 Picasso B78,-  
Peugeot 308 T9



Code	Desc.
2930112506	12506

Measurements mm:d.5,2  
Application :Citroen DS5-Peugeot 3008  
-5008



Code	Desc.
2930112910	12910

Measurements mm:d.8,5  
Application :Citroen C1-Peugeot 108 -  
Toyota Aygo,Corolla,Kluger,Highlander

## Renault-Dacia



Code	Desc.
2930100132	132

Misure mm: Ø 8  
Applicazione: Collare di tenuta



Code	Desc.
2930100340	340

Misure mm: Ø 8  
Applicazione: Trafic, R9-R11

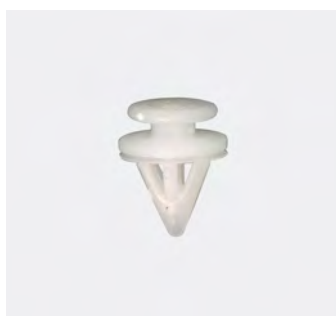

Code	Desc.
2930101224	1224

Misure mm: Ø 8,2  
Applicazione: Tutti i tipi

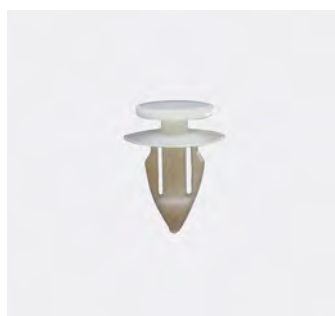

Code	Desc.
2930101173	1173

Misure mm: Ø 8,2  
Applicazione: R21, R25 Megane II  
Si monta con il cod.132

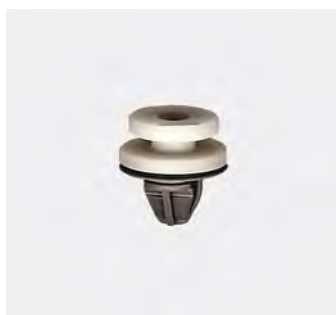

Code	Desc.
2930101327	1327

Misure mm: Ø 8,2  
Applicazione: Tutti i tipi



Code	Desc.
2930101336	1336

Misure mm: Ø 7,5  
Applicazione: Laguna  
Si monta con il cod.132



Code	Desc.
2930110435	10435

Misure mm: Ø 8,2  
Applicazione: Tous types

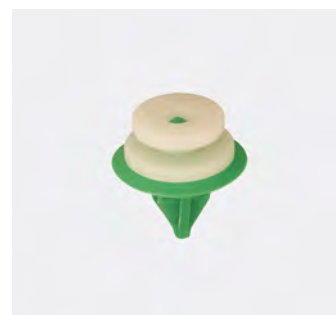

Code	Desc.
2930110445	10445

Misure mm: Ø 8,2 à 8,5  
Applicazione: Bordatura laterale tutti i tipi

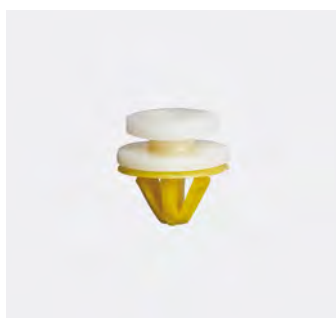

Code	Desc.
2930110448	10448

Misure mm: Ø 8,2  
Applicazione: Master, Trafic

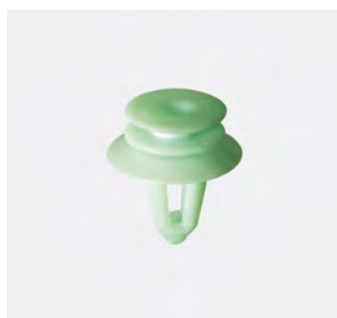

Code	Desc.
2930110692	10692

Misure mm: Ø 8  
Applicazione: Vel Satis Espace IV



Code	Desc.
2930110777	10777

Misure mm: Ø 8,2  
Applicazione: Vel Satis, Clio III



Code	Desc.
2930110790	10790

Misure mm: Ø 8,2  
Applicazione: Tutti i tipi

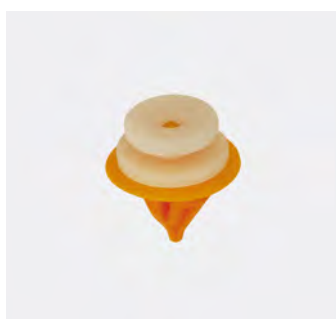

Code	Desc.
2930110840	10840

Misure mm: Ø 8,2  
Applicazione: Laguna II, Espace IV, Modus

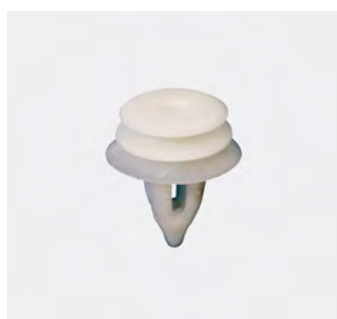

Code	Desc.
2930111152	11152

Misure mm: Ø 8  
Applicazione: Logan Sandero



Code	Desc.
2930111376	11376

Misure mm: Ø 8  
Applicazione: Laguna II Master II



Code	Desc.
2930111638	11638

Misure mm: Ø 8,2  
Applicazione: Kangoo II, Megane, Scenic III



Code	Desc.
2930111642	11642

Misure mm: Ø 8,2  
Applicazione: Duster, Master III, Megane III CC

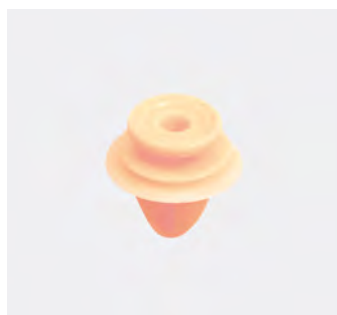

Code	Desc.
2930111650	11650

Misure mm: Ø 8,2  
Applicazione: Duster, Master III, Wind III



Code	Desc.
2930111811	11811

Misure mm: Ø 8,2  
Applicazione: Duster, Clio III, Kangoo II, Megane III, Sandero

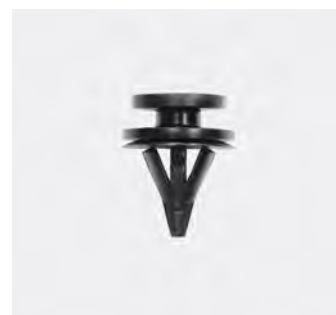

Code	Desc.
2930112163	12163

Measurements mm:d.8,2  
Application :Renault Clio II-Megane I - Scenic I e II ,Zoe

## Toyota



Code	Desc.
2930112902	12902

Measurements mm:d.8,5  
Application : Toyota Auris,Camry,Rav4, Corolla,Prius,Yaris.Land Cruiser IS,ES,GX

## VW-Audi-Seat-Skoda



Code	Desc.
2930101409	1409

Misure mm: Ø 9  
Applicazione: Golf III



Code	Desc.
2930101410	1410

Misure mm: Ø 9  
Applicazione: Polo 95



Code	Desc.
2930101413	1413

Misure mm: Ø 7 à 7,2  
Applicazione: Golf II



Code	Desc.
2930101414	1414

Misure mm: Ø 7 à 7,2  
Applicazione: Golf II





Code	Desc.
2930110347	10347

Misure mm: Ø 8 a 8,2  
Applicazione: Sharan, Toledo 3, Alhambra



Code	Desc.
2930110628	10628

Misure mm: Ø 10  
Applicazione: A3, A4



Code	Desc.
2930110669	10669

Misure mm: Ø 8,2  
Applicazione: Ibiza, Cordoba



Code	Desc.
2930110692	10692

Misure mm: Ø 8  
Applicazione: Fabia, Octavia II, Roomster



Code	Desc.
2930110723	10723

Misure mm: Ø 8 a 8,2  
Applicazione: Polo 2002, Golf V, Touran, A6, Passat, Tiguan, Superb



Code	Desc.
2930111188	11188

Misure mm: Ø 10  
Applicazione: A3 et A3, Sportback



Code	Desc.
2930111216	11216

Misure mm: Ø 5  
Applicazione: Fox, Golf VI, Tiguan, Scirocco, Seat Ibiza 2006



Code	Desc.
2930111511	11511

Misure mm: Ø 8,2  
Applicazione: Fox



Code	Desc.
2930111571	11571

Misure mm: Ø 8 a 8,3  
Applicazione: Touareg, Golf VI, Scirocco, A4, Polo, T5



Code	Desc.
2930112262	12262

Misure mm: Ø 8  
Applicazione: VW Up, Skoda tutti i tipi



Code	Desc.
2930112438	12438

Misure mm: Ø 8,2  
Applicazione: VW Crafter



Code	Desc.
2930112823	12823

Application: Audi A3



Code	Desc.
2930101497	1497

Measurements mm:d.6,5  
Application : Audi A5

## Fiat



Code	Desc.
2930000971	971

**D=21 L=14,5 H=12 Ø=5MA**  
Nut screw rear - Fiat Bravo, Brava,  
Marea.

## Ford



Code	Desc.
2930100362	362

Spessore lamiera mm: 0,7-1,5  
Ø vite mm: 6,35  
Dimensioni mm : 24 x 16  
Applicazione: Ali Ford



Code	Desc.
2930110343	10343

Spessore lamiera mm: 0,7 à 4  
Ø vite mm: 6  
Dimensioni mm : 23,8 x 16  
Applicazione: Ford

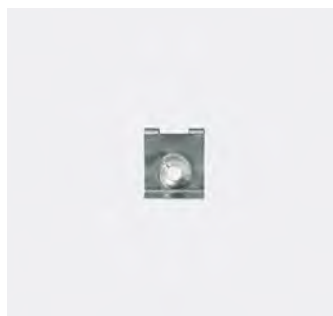

Code	Desc.
2930111168	11168

Spessore lamiera mm: 1 a 2,8  
Ø vite mm: 4,8  
Dimensioni mm : 16 x 18,6  
Applicazione: Ford

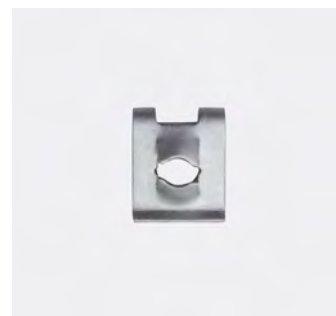

Code	Desc.
2930112139	12139

Spessore lamiera mm: 1 a 2,8  
Ø vite mm: 4,8  
Dimensioni mm : 12 x 14,3  
Applicazione: Ford

## Mercedes-Smart



Code	Desc.
2930100362	362

Spessore lamiera mm: 0,7-1,5  
 Ø vite mm: 6,35  
 Dimensioni mm : 24 x 16  
 Applicazione: Ali Mercedes

## Opel



Code	Desc.
2930100362	362

Spessore lamiera mm: 0,7-1,5  
 Ø vite mm: 6,35  
 Dimensioni mm : 24 x 16  
 Applicazione: Ali Opel

## Peugeot-Citroën



Code	Desc.
2930100400	400

Spessore acciaio mm: 0,5 à 4  
 Vite Ø mm: 6  
 Dimensioni mm: 22,2x15  
 Assegnazione: Peugeot, Citroën, Renault



Code	Desc.
2930112430	12430

Spessore lamiera mm: 0,5 a 4  
 Ø vite mm: 6  
 Dimensioni mm : 23 x 15  
 Applicazione: Peugeot, Citroën

BMW-Mini



Code	Desc.
2930110328	10328

Misure mm: Ø 6,5 à 7,25  
Applicazione: Tutti i tipi



Code	Desc.
2930110376	10376

Misure mm: Ø 6,5  
Applicazione: Tutti i tipi



Code	Desc.
2930111959	11959

Misure mm: Ø 6,5  
Applicazione: Serie 3, 5, 6, X3, X5, X6, Z4



Code	Desc.
2930112044	12044

Applicazione: E36, E38



Code	Desc.
2930112045	12045

Applicazione: E39, E53, E70



Code	Desc.
2930112645	12645

Misure mm: Ø 7,8 a 8,8  
Applicazione: Serie 1, 3, 5, 6, 7, X6, Z3



Code	Desc.
2930112655	12655

Misure mm: Ø 8  
Applicazione: tutti i tipi



Code	Desc.
2930112676	12676

Misure mm: Ø 12  
Applicazione: Serie 1, 3, 7, X1, X3, Z4



Code	Desc.
2930112683	12683

Misure mm: 5,9 a 25 T13  
Applicazione: X3, X5, X6



Code	Desc.
2930112684	12684

Misure mm: 5,9 x 19 T20  
Applicazione: Serie 3, X1, X3, X5, X6, Z4, Mini Countryman, Paceman



Code	Desc.
2930004066	4066

Ø 6,5 T 20  
Black Colour. Rivet bumper BMW 3



**Fiat-Alfa Romeo-Lancia**

Code	Desc.
2930002052	2052



Code	Desc.
2930000421	421

**hole Ø=10**

Rivet fastening coatings Fiat Cromia, Punto, Lancia Delta, Prisma, Thema.

**Hole Ø=10,5**

Black Colour. Rivet fastening shelter wheel compartment Ford Fiesta, Escort.

**Mercedes-Smart**

Code	Desc.
2930110376	10376

 Misure mm: Ø 6,5  
 Applicazione: Tutti i tipi

Code	Desc.
2930112644	12644

 Misure mm: Ø 5 à 5,5  
 Applicazione: Classe CL, E, ML, GL, R, S, SL, SLK

Code	Desc.
2930112645	12645

 Misure mm: Ø 7,8 à 8,8  
 Applicazione: Classe ML, GL

Code	Desc.
2930112648	12648

 Misure mm: Ø 5,9 à 7,1  
 Applicazione: Classe CLK, CL, CLS, S, SL, SLK

Code	Desc.
2930112650	12650

 Misure mm: Ø 8  
 Applicazione: Classe B

Code	Desc.
2930112655	12655

 Misure mm: Ø 8  
 Applicazione: Classe CL, ML, GL, R, S, SLK, Sprinter

Code	Desc.
2930112656	12656

 Misure mm: Ø 9,2 x 13  
 Applicazione: tutti i tipi

Code	Desc.
2930112657	12657

 Misure mm: Ø 8,5  
 Applicazione: Classe A, C, CL, CLK, CLS, E, S, SLK

## Peugeot-Citroën



Code	Desc.
2930100442	442

Misure mm: Ø 6  
Applicazione: 206, AX, Berlingo



Code	Desc.
2930100443	443

Misure mm: Ø 8,5  
Applicazione: 106, 309, 605, Saxo



Code	Desc.
2930101152	1152

Misure mm: Ø 5,5  
Applicazione: vecchi modelli



Code	Desc.
2930101271	1271

Misure mm: Ø 6,2  
Applicazione: Tutti i tipi



Code	Desc.
2930101272	1272

Misure mm: Ø 6  
Applicazione: Cavo ripiano posteriore - tutti i tipi



Code	Desc.
2930101273	1273

Misure mm: Ø 6,2  
Applicazione: 106, 207, 306, 307, 308, 607, 1007, Xsara, Picasso, Xantia, C4 Picasso, C5



Code	Desc.
2930109096	9096

Misure mm: Ø 4  
Applicazione: 206



Code	Desc.
2930109942	9942

Misure mm: Ø 8  
Applicazione: 206, 306, 406, Xsara



Code	Desc.
2930110464	10464

Misure mm: Ø 8,2  
Applicazione: 307, 607, 807 C3, C4, C5, C8



Code	Desc.
2930110484	10484

Misure mm: Ø 6,2  
Applicazione: Xsara Picasso, 407 SW, C5/X7, B9



Code	Desc.
2930110735	10735

Misure mm: Ø 8  
Applicazione: 207, 407, 807, C2, C3, C4 Picasso, C5, C8



Code	Desc.
2930110810	10810

Misure mm: Ø 5,5  
Applicazione: 307



Code	Desc.
2930111470	11470

Misure mm: Ø 8 à 8,2  
Applicazione: Tutti i tipi



Code	Desc.
2930111549	11549

Misure mm: Ø 6,2  
Applicazione: 206, 1007



Code	Desc.
2930112216	12216

Misure mm: Ø 8,5  
Applicazione: Boxer III, Jumper III

## Renault-Dacia



Code	Desc.
2930101271	1271

Misure mm: Ø 6,2  
Applicazione: cofano - tutti i tipi



Code	Desc.
2930110443	10443

Misure mm: Ø 8  
Applicazione: Scenic RX4



Code	Desc.
2930110444	10444

Misure mm: Ø 6,2  
Applicazione: Cofano - Tutti i tipi



Code	Desc.
2930110484	10484

Misure mm: Ø 6,2  
Applicazione: Clio III



Code	Desc.
2930110553	10553

Misure mm: Ø 8,2  
Applicazione: Cofano - Tutti i tipi



Code	Desc.
2930111286	11286

Misure mm: Ø 8 à 10  
Applicazione: Kangoo, Master



Code	Desc.
2930111777	11777

Misure mm: Ø 10  
Applicazione: Latitude



Code	Desc.
2930112130	12130

Misure mm: Ø 8 à 8,2  
Applicazione: Tutti i tipi



Code	Desc.
2930110182	10182

Measurements: d.4,6mm  
Application: Renault Master II

## VW-Audi-Seat-Skoda



Code	Desc.
2930110317	10317

Misure mm:21,5 à 23,5  
 Applicazione: Volkswagen, Audi, Seat -  
 tutti i tipi



Code	Desc.
2930110636	10636



Code	Desc.
2930110672	10672

Misure mm:27  
 Applicazione: Volkswagen, Audi, Seat -  
 tutti i tipi



## Peugeot-Citroën



Code	Desc.
2930101431	1431

Dimensioni mm: 6 x 20  
Applicazione: Peugeot, Citroën



Code	Desc.
2930110758	10758

Spessore rivettabile mm: 0,5 à 1,5  
Dimensioni mm: 7,5 x 25  
Applicazione: Peugeot, Citroën



Code	Desc.
2930111174	11174

Measurements mm: d.7,5x30  
Thickness lockable da 2 a 13mm  
Application : Citroen,Peugeot,Renault

## Tutti i Modelli



Code	Desc.
2930100653	653

Dimensione mm: 6,35 x 19  
Ø rondella mm: 18



Code	Desc.
2930111010	11010

Dimensione mm: 4,8 x 19  
Ø rondella mm: 16



Code	Desc.
2930111023	11023

Dimensione mm: 5,5x19  
Ø rondella mm: 15



Code	Desc.
2930101450	1450

Dimensione mm: 6 x 20



Code	Desc.
2930000002	2

**Vite = Ø 3,5 Foro quadro=8**  
Colore azzurro. Madrevite fissaggio rivestimenti interni Fiat Panda, Cromia, Punto, Multipla, Lancia Thema.



Code	Desc.
2930000003	3

**Vite = Ø 5,5 Foro quadro=11**  
Colore giallo. Madrevite fissaggio maniglia appiglio e rivestimenti interni Fiat 126, Panda, Nuova Punto. Paraurti Multipla.



Code	Desc.
2930000004	4

**Vite = Ø 4,2 Foro quadro=10**  
Colore rosso. Madrevite fissaggio tasca su porta, supporto pianale cappelliera Fiat Panda.



Code	Desc.
2930000005	5

**Vite = Ø 5,5 Foro=11**  
Colore naturale. Madrevite fissaggio maniglia appiglio Fiat Panda. Varie applicazioni Lancia Y10.



Code	Desc.
2930000006	6

**Vite = Ø 4,2 Foro quadro=9**  
 Colore verde. Madrevite  
 fissaggio cerniera porta Fiat Uno, Tipo,  
 Tempra, Cromia, Lancia Delta, Y10.  
 Madrevite fissaggio riparo vano ruota  
 Fiat Tipo, Tempra, Cinquecento, Bravo,  
 Brava, Marea, Alfa 145, 146, Lybra.

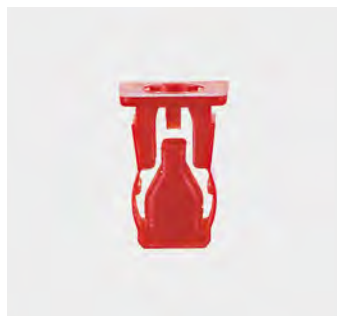

Code	Desc.
2930000007	7

**Vite = Ø 4,8 Foro quadro=10**  
 Colore rosso. Madrevite  
 fissaggio rivestimenti interni Fiat 126,  
 Panda, Uno, Lancia Y10, K.



Code	Desc.
2930000084	84
2930000086	86
2930000085	85

**Ø84=M5 Ø85=M6 Ø86=M8**  
 Dado in gabbia per varie applicazioni  
 - Universali.  
 Spessore di utilizzo:  
 M5=2,7 M6=2,7 M8=3 mm



Code	Desc.
2930000098	98

**Ø M6**  
 Zincatura gialla. Dado in gabbia per  
 varie applicazioni - Renault - Ford.



Code	Desc.
2930000474	474
2930000475	475
2930000476	476

Misure 474  
**ØT=16,7 ØF min/max.=9,5/13,5**  
 Misure 475  
**ØT=24,8 ØF min/max.=14/21**  
 Misure 476  
**ØT=34,8 ØF min/max.=22/30**  
 Colore nero. Tappo copriforo universale.



Code	Desc.
2930000628	628

**Internal diameter: M6; Outside  
 diameter: 9; H: 15.5**  
 Yellow zinc. Special insert rivetable.  
**Countersunk head.**



Code	Desc.
2930000632	632

**Ø internal = M6 outside diameter =  
 9**  
**ØT. = 13 H = 14 thickness = 1.5**  
 Yellow zinc. Cylindrical insert rivetable.  
 Injection - Transmission - Hydraulic  
 Power Steering System - Bravo / a, Tide,  
 A, Duchy.



Code	Desc.
2930000635	635

**Ø internal Ø external = M8 = 14 H =  
 6**  
 Galvanized white. Insert rivetable  
 cylindrical, **countersunk head**, shelter  
 frame - Bravo / a, Marea. knurled



Code	Desc.
2930000663	663

**Ø Internal.=M6 Ø external=9**  
**ØT.=12 H=15 thickness T=1,5**  
 White zinc. Special insert Fiat Unified.

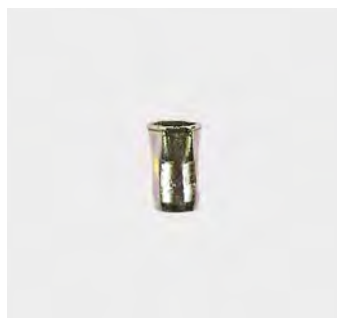

Code	Desc.
2930000669	669

**Ø internal Ø = M4 hexagon = 6**  
**ØT. = 7 H = 10 thickness T = 0.5**  
 Yellow zinc. Insert rivetable - Fiat all  
 kinds.



Code	Desc.
2930000671	671

**Internal diameter: M6; Ø Hexagon:  
 9; Ø t.: 10; X: 15; thickness t.: 1**  
 Yellow zinc. Insert rivetable fixing liners  
 fiat panda. Fender Fiat Punto (1st  
 series), Fiat Bravo, Brava.



Code	Desc.
2930000672	672

**Ø int.=M6 Ø esag.=9**  
**ØT.=16 H=14,5 Spess.T=2,5**  
 Zincatura gialla. Inserto rivetabile  
 fissaggio parafrangente - Fiat Uno, Marea,  
 Bravo, Bravo, Palio, Multipla, Nuova  
 Punto - Lancia Dedra, Voletto Lancia  
 Y10, Y, Lybra, 145, 146, 147, 156



Code	Desc.
2930000675	675

**Ø internal = M6 hexagon Ø = 9**  
**ØT. = 13 H = 22 thickness T = 1.5**  
 Yellow zinc. Blind. Insert rivetable  
 Fender fixing - Fiat Tipo, Tempra. Rear  
 bumper Fiat Palio.



Code	Desc.
2930000676	676
2930000679	679

**Measures 676 = internal diameter =**  
**M6 hexagon Ø = 9**  
**ØT. = 17 H = 14 thickness T = 1.4**  
**Measures 679 = internal diameter =**  
**Ø M8 hex = 14**  
**ØT. = 16 H = 16 thickness T = 1.4**  
 Yellow zinc. Insert rivetable fixing  
 fenders Lancia Y, Fiat Punto, Doblo.



Code	Desc.
2930000680	680

**Internal diameter: M4; Ø Hexagon:**  
**6; Øt.: 9; H: 9; thickness t.: 1**  
 Yellow zinc. Insert rivetable fixing stone  
 guard - Fiat Cinquecento, Seicento.  
 Seats Fiat Uno.



Code	Desc.
2930000682	682

**Ø int.=M5 Ø esag.=7**  
**ØT.=10 H=20 Spess.T=1**  
 Zincatura gialla. Inserto rivettabile  
 unificato. Cieco.  
 Seats Fiat Uno.



Code	Desc.
2930003024	3024
2930000683	683

**Measures 3024 = internal diameter =**  
**M6 hexagon Ø = 9**  
**ØT. = 23 H = 27 thickness T = 1.5**  
**Measures 683 = internal diameter =**  
**Ø M8 hex = 11**  
**ØT. = 16 H = 25 thickness = 1.5 .T**  
 Yellow zinc. Blind. Rivettable insert on  
 rear cross - Fiat Bravo, Brava, Marea,  
 Punto, Multipla, New Point - Lancia Y.



Code	Desc.
2930000798	798
2930000799	799
2930000800	800
293 00 00796	796

**798 nero=4,8x16**  
**799 nero=4,8x19**  
**800 giallo=5,5x19**  
**796 giallo=6,3x19**  
 Zincatura. Vite autofilettante fissaggi  
 vari (con rondella imperdibile).



Code	Desc.
2930000958	958

**Internal diameter = Ø M5 hex = 7**  
**ØT. = 10 H = 18 thickness T = 1**  
 Yellow zinc. Insert rivetable fixing  
 handles - Fiat Bravo, Brava, Spoiler Side  
 Road - Fiat Punto. Roof lining Fiorino.



Code	Desc.
2930002035	2035

**D=16 L=11 H=8,5 Ø=3,5**  
 Metal nut for various applications -  
 Universal.

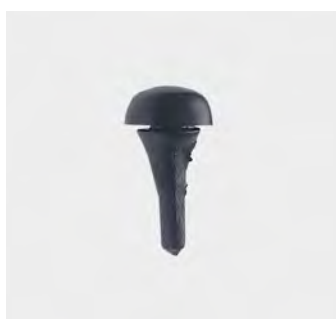

Code	Desc.
2930002071	2071

**H=6,5**  
 Paracolpo cofano H=6,5 in gomma.

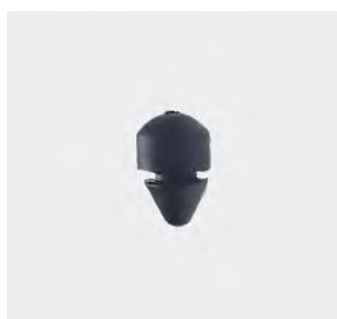

Code	Desc.
2930002073	2073

Paracolpo porta in gomma Fiat Panda.



Code	Desc.
2930003018	3018

**Ø internal = M6 hexagon Ø = 9**  
**ØT. = 10 H = 16 thickness T = 1**  
 Yellow zinc. Insert rivetable fixing  
 pavilion roof - Fiat Bravo, Brava. Blind.



Code	Desc.
2930003025	3025

**Ø int.=M6 Ø esag.=9**  
**ØT.=17 H=14 Spess.T=4,5**  
 Zincatura gialla. Inserto rivettabile  
 fissaggio parafango - Fiat Bravo, Brava,  
 Marea, Thesis.



Code	Desc.
2930003028	3028

**Ø int.=M6 Ø esag.=9  
ØT.=13 H=14,5 Spess.T=1**  
Zincatura gialla. Inserto rivettabile fissaggio parafrangente - Fiat Punto, Palio, Nuova Punto, Bravo '98, Bravo '98.

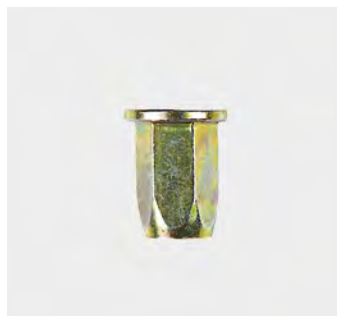

Code	Desc.
2930003096	3096

**Ø internal = M6 hexagon Ø = 9  
ØT. = 13 H = 14 thickness T = 1.5**

Yellow zinc. Insert rivettable fixing bumper - Fiat Cinquecento. Door and tailgate - Fiat Punto, Bravo, Brava, Marea, Palio, Multipla, New Point - Peugeot 205, 306, 309. fender - Lancia Kappa, Lybra, Thesis.



Code	Desc.
2930004685	4685

**T=Ø 10.- M5 - H14 Ø=12,9**  
Dado - inserto/speciale varie applicazioni su vari modelli Alfa Romeo, Fiat e Lancia Dedra.



Code	Desc.
2930004985	4985

6x20-Vite autofilettante speciale zincata bianca per parafrangente Bravo '07 Grandepunto dopo '05 Nuova 500 '07. In Opposizione a ns. 293 00 05090



Code	Desc.
2930000090	90
2930000091	91
2930000092	92

**Ø=M5  
L=12,4mm H=5,8mm Spessore=0,8mm**  
Dado in gabbia per varie applicazioni - Universale.



Code	Desc.
2930000101	101

**Ø=M6**  
Cage nut for various applications - Universal.



Code	Desc.
2930000449	449

**449=4,3x13**  
Under-screws in burnished iron



## Plastic parts trolley



Code	Desc.	H	P	L1	L2
2930100066	66	89 cm	40 cm	56 cm	40 cm

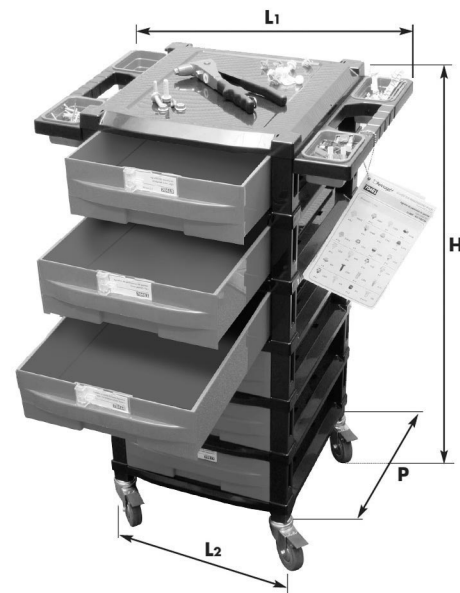

Acquista 6 assortimenti tra quelli disponibili e riceverai  
**GRATUITAMENTE** Il carrello minuterie metalliche!

Gli assortimenti sono progettati esclusivamente per la composizione  
del carrello minuterie metalliche cod. 2930100066



**OMAGGIO**





## Mini madia 2 drawers



Code	Description
2930100067	R67 mini madia 2 drawers

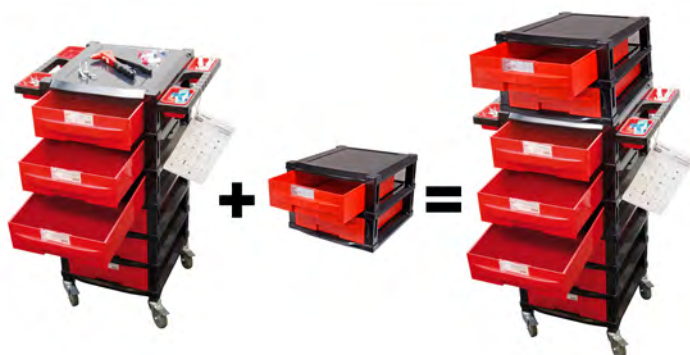
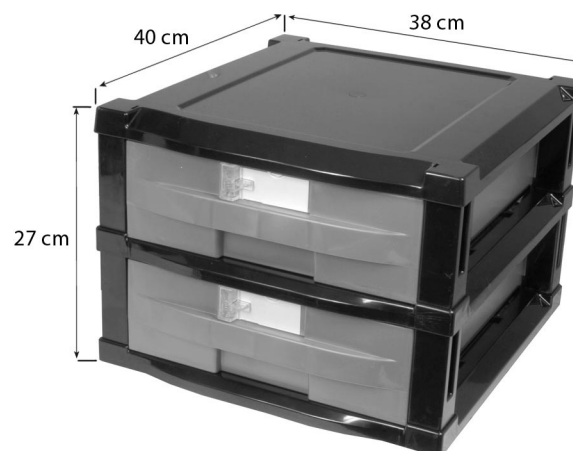

Acquista **2** assortimenti tra quelli disponibili e riceverai **GRATUITAMENTE** La mini madia 2 cassetti!

Termoformati non fornibili vuoti

**OMAGGIO**



## Fissaggi generici - Tutti i modelli



- Clip Trim
- 15 codici - 384 pezzi
- Tutti i marchi europei
- \* **Non acquistabile singolarmente**

Code	Desc.
2930170402	70402

## Fissaggi generici - Renault-Dacia



- Clip Trim
- 17 codici - 420 pezzi
- Per veicoli tipo RENAULT
- \* **Non acquistabile singolarmente**

Code	Desc.
2930170420	70420

## Fissaggi generici - Peugeot-Citroën



- Clip Trim
- 17 codici - 425 pezzi
- Per veicoli tipo PEUGEOT, CITROËN
- \* **Non acquistabile singolarmente**

Code	Desc.
2930170423	70423

**Fissaggi generici - Fiat-Alfa Romeo-Lancia**

- Clip
- 22 codici - 434 pezzi
- Per veicoli tipo FIAT, ALFA ROMEO, LANCIA
- \* **Non acquistabile singolarmente**

Code	Desc.
2930170428	70428

**Fissaggi generici - VW-Audi-Seat-Skoda**

- Clip
- 21 codici - 408 pezzi
- Per veicoli tipo AUDI, SEAT, SKODA, VOLKSWAGEN
- \* **Non acquistabile singolarmente**

Code	Desc.
2930170436	70436

**Fissaggi generici - Mercedes-Smart**

- Clip
- 24 codici - 587 pezzi
- Per veicoli tipo MERCEDES
- \* **Non acquistabile singolarmente**

Code	Desc.
2930170439	70439



### Fissaggi generici - BMW-Mini



- Clip
- 19 codici - 530 pezzi
- Per veicoli tipo BMW
- \* **Non acquistabile singolarmente**

Code	Desc.
2930170441	70441

### Fissaggi generici carrozzeria esterna - VW-Audi-Seat-Skoda



- Graffette per carenatura sotto motore
- 24 codici - 310 pezzi
- Per veicoli tipo VOLKSWAGEN, AUDI, SEAT, SKODA
- \* **Non acquistabile singolarmente**

Code	Desc.
2930170429	70429

### Fissaggi generici carrozzeria esterna - Renault-Dacia



- Graffette per carenatura sopra motore e sotto motore
- 18 codici - 304 pezzi
- Per veicoli tipo RENAULT, DACIA
- \* **Non acquistabile singolarmente**

Code	Desc.
2930170430	70430

## Fissaggi generici carrozzeria esterna - Peugeot-Citroën



- Grafette per carenatura sopra motore e sotto motore
- 20 codici - 238 pezzi
- Per veicoli tipo PEUGEOT, CITROËN
- \* **Non acquistabile singolarmente**

Code	Desc.
2930170431	70431

## Fissaggi modanature esterne - Tutti i Modelli



- Clip di stampaggio
- 20 codici - 370 pezzi
- Per veicoli tipo : Tutte le marche europee
- \* **Non acquistabile singolarmente**

Code	Desc.
2930170403	70403

## Fissaggi modanature esterne - Renault-Dacia

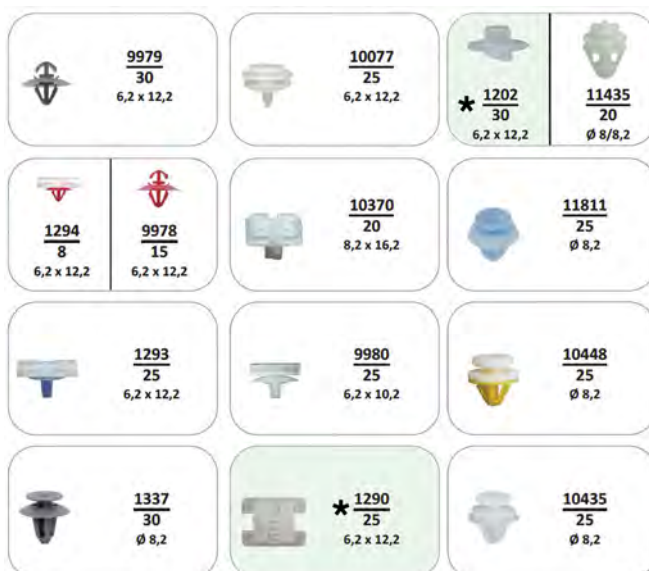

- Clip di stampaggio
- 14 codici - 328 pezzi
- Per veicoli tipo RENAULT
- \* **Non acquistabile singolarmente**

Code	Desc.
2930170419	70419



## Pannelli portiere - Tutti i Modelli



- Graffette pannelli porta
- 23 codici - 423 pezzi
- Per veicoli tipo: Tutte le marche europee
- \* **Non acquistabile singolarmente**

Code	Desc.
2930170401	70401

## Rivetti plastici - Tutti i Modelli

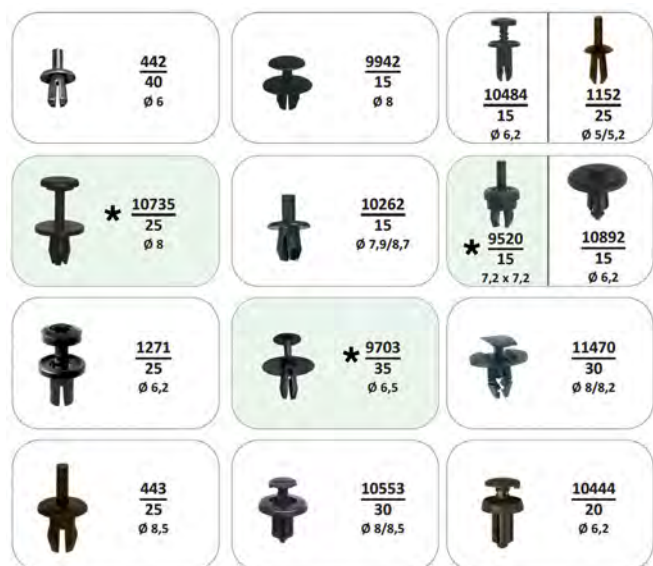

- Graffette pannelli e modanature
- 14 codici - 330 pezzi
- Per veicoli tipo : Tutte le marche europee
- \* **Non acquistabile singolarmente**

Code	Desc.
2930170404	70404

## Rivetti plastici - Tutti i Modelli



- Graffette pannelli e modanature
- 15 codici - 375 pezzi
- Per veicoli tipo : Tutte le marche europee
- \* **Non acquistabile singolarmente**

Code	Desc.
2930170437	70437

**Refill windscreen wiper car**

Per non cambiare più tutto il tergicristallo...  
Risparmiando e inquinando di meno ora  
c'è Refil M, si applica in pochi secondi  
al vecchio tergicristallo (sostituendo  
solo la gomma usata)

- Refill in pure natural rubber and ABS frame.
- Long life and high resistance to different temperatures.
- Quiet operation even in the presence of ice, snow, rain, sand and dust.
- Adaptable to all vehicles, boats.

Code	Desc.	Measure	Application
2980000100	63610	6,3x610	AUTO
2980000200	63650	6,3x650	TWINGO

**Wiper blades Wipermec**

- Wiper blades standard model with steel structure for passenger cars and commercial vehicles.
- Indicate for body shops and car and truck repair shops, service stations, car dealerships, car dealerships, car washes.
- Building with a painted galvanized steel frame in epoxy powder, resistant to weathering and the action of ultraviolet rays. Mounting stainless steel rivets.
- Rubber high quality detergent, coated graphite, from the long resistance to extremely low temperatures and high, the sun, to salt. It maintained over time the good properties without wiping streaks and extreme quiet operation.
- The perforated carrying structure prevents the brush to rise even at high speeds. The two stainless steel plates inserted in the rubber allow it to adhere to the crystals also in presence of strong curvatures.
- With multi-function mount mounted.

Code	Desc.	Measure mm /"
2980002400	CX350	350/14
2980002410	CX375	375/15
2980002420	CX400	400/16
2980002430	CX450	450/18
2980002440	CX480	475/19
2980002450	CX500	500/20
2980002460	CX525	525/21
2980002470	CX550	550/22
2980002480	CX580	580/23
2980002490	CX600	600/24
2980002600	CX650	650/26

## Wiper blades Wiper HD



- Wiper blades standard for heavy commercial vehicles and construction.
- Indicate for body shops and repair shops, industrial, service stations, dealerships, car washes, hauliers.
- Rubber high quality detergent, coated graphite, from the long resistance to extremely low temperatures and high, the sun, to salt. It maintained over time the good properties without wiping streaks and extreme quiet operation.
- Package equipped with universal adapters easy to apply for the mounting of the brushes on each type of motor vehicle which mounts this type of wiper as the first plant.
- The codes (\*) are furnished with sprinkler it is not to mark meccanocar.
- From the 550 to the 700 new all-rubber range.

Code	Desc.	Measure mm /"	Photo
2980002605	HD550	550/22	1
2980002610	HD600	600/24	1
2980002620	HD650	650/26	1
2980002630	HD700	700/28	1
2980001425	HD1000	1000/39	2
2980001795	HD600S *	600/24	3
2980001805	HD650S *	650/26	3
2980001815	HD700S *	700/28	3

## Wiper blades Mecflex Universal



- Wiper blades "Flat" model all rubber, with steel internal structure, for passenger cars and commercial vehicles. Universal mounting even on vehicles equipped in first plant with steel brushes.
- Indicate for body shops and car workshops and industrial vehicles, service stations, car dealerships, car dealerships, car washes, drivers.
- Construct with a great wind resistance at low profile structure that ensures and at high speeds. top rubber with an aerodynamic profile that promotes the adhesion to the glass. Extremely flexible for use even on highly curved crystals.
- Rubber high quality detergent, coated graphite, from the long resistance to extremely low temperatures and high, the sun, to salt. It maintained over time the good properties without wiping streaks and extreme quiet operation.
- Package equipped with universal adapters easy to apply for the mounting of the brushes on each type of motor vehicle, also of last generation.

Code	Desc.	Measure mm /"
2980002700	FU350	350/14
2980002710	FU375	375/15
2980002720	FU400	400/16
2980002730	FU425	425/17
2980002740	FU450	450/18
2980002750	FU475	475/19
2980002760	FU500	500/20
2980002770	FU525	525/21
2980002780	FU550	550/22
2980002790	FU575	575/23
2980002800	FU600	600/24
2980002810	FU625	625/26
2980002820	FU700	700/28

## Wall expositor for wiper blades



- Display for wall mounting, made of steel rod painted with scratch-proof epoxy powder, with 9 arms for the display of wiper blades.
- Wall mounting by two screw anchors included.  
Dimensions: 690 x 275 mm h.

Code	Description	Measures L x H mm
2980001600	Wall expositor 9 arms	690 x 275

## Floor expositor for wiper blades



- Wheeled exhibitor tubular steel painted with scratch resistant epoxy powder, with 9 arms for the display of wiper blades.
- Equipped with two free rotating wheels and two swivel wheels with brakes. Dimensions: 550 x 430 x 1660 mm h.

Code	Description	Measures L x h x P mm
2980001610	Floor expositor	550 x 1660 x 430



## Wall kit car 26 pieces



- Complete kit of assorted wiper blades Wipermec and Mecflex Universal, 26 pieces in total, made up of the most used in the automotive and commercial vehicle sector measures.
- Kit includes our wall bracket code 2980001600.

Code	Description
2980001662	EXPO6/N

Contenuto del kit			
Codice	Descrizione	Articolo	N° pezzi
2980002400	CX350	Tergi Wipermec 350 mm	2
2980002420	CX400	Tergi Wipermec 400 mm	2
2980002430	CX450	Tergi Wipermec 450 mm	2
2980002440	CX480	Tergi Wipermec 480 mm	2
2980002450	CX500	Tergi Wipermec 500 mm	2
2980002470	CX550	Tergi Wipermec 550 mm	2
2980002730	FU400	Tergi Mecflex Universal 400 mm	2
2980002740	FU450	Tergi Mecflex Universal 450 mm	2
2980002750	FU475	Tergi Mecflex Universal 475 mm	2
2980002760	FU500	Tergi Mecflex Universal 500 mm	2
2980002780	FU550	Tergi Mecflex Universal 550 mm	2
2980002800	FU600	Tergi Mecflex Universal 600 mm	2
2980002810	FU625	Tergi Mecflex Universal 625 mm	2

## Wall kit truck 26 pieces



- Complete kit with assorted brushes wipers Wipermec, Wiper HD and Mecflex Universal, 26 pieces in total, made up of the most used in the auto industry, and commercial means measures.
- Kit includes our wall bracket code 2980001600.
- Kit includes our wall bracket code 2980001600.

Code	Description
2980001672	EXPO7/N

Contenuto del kit			
Codice	Descrizione	Articolo	N° pezzi
2980002400	CX350	Tergi Wipermec 350 mm	2
2980002420	CX400	Tergi Wipermec 400 mm	2
2980002430	CX450	Tergi Wipermec 450 mm	2
2980002440	CX480	Tergi Wipermec 480 mm	2
2980002450	CX500	Tergi Wipermec 500 mm	2
2980002620	HD650	Tergi Wiper HD 650 mm	2
2980002630	HD700	Tergi Wiper HD 700 mm	2
2980002730	FU400	Tergi Mecflex Universal 400 mm	2
2980002740	FU450	Tergi Mecflex Universal 450 mm	2
2980002750	FU475	Tergi Mecflex Universal 475 mm	2
2980002780	FU550	Tergi Mecflex Universal 550 mm	2
2980002800	FU600	Tergi Mecflex Universal 600 mm	2
2980002810	FU625	Tergi Mecflex Universal 625 mm	2



## Floor wheeled car kit 54 pieces



- Complete kit of assorted wiper blades Wipermec and Mecflex Universal, 54 pieces in total, made up of the most used in the automotive and commercial vehicle sector measures.
- Kit includes our wall bracket code 2980001610.

Code	Description
2980001642	EXPO 4/N

Contenuto del kit			
Codice	Descrizione	Articolo	N° pezzi
2980002400	CX350	Tergi Wipermec 350 mm	2
2980002420	CX400	Tergi Wipermec 400 mm	2
2980002430	CX450	Tergi Wipermec 450 mm	6
2980002440	CX475	Tergi Wipermec 475 mm	2
2980002450	CX500	Tergi Wipermec 500 mm	4
2980002460	CX525	Tergi Wipermec 525 mm	2
2980002470	CX550	Tergi Wipermec 550 mm	6
2980002490	CX600	Tergi Wipermec 600 mm	2
2980002710	FU375	Tergi Mecflex Universal 375 mm	2
2980002720	FU400	Tergi Mecflex Universal 400 mm	4
2980002730	FU425	Tergi Mecflex Universal 425 mm	2
2980002740	FU450	Tergi Mecflex Universal 450 mm	2
2980002750	FU475	Tergi Mecflex Universal 475 mm	2
2980002760	FU500	Tergi Mecflex Universal 500 mm	2
2980002770	FU525	Tergi Mecflex Universal 525 mm	2
2980002780	FU550	Tergi Mecflex Universal 550 mm	2
2980002790	FU575	Tergi Mecflex Universal 575 mm	2
2980002800	FU600	Tergi Mecflex Universal 600 mm	4
2980002810	FU625	Tergi Mecflex Universal 625 mm	4

## Floor kit wheeled truck 54 pieces



- Complete kit of assorted wiper blades Wipermec, Wiper HD and Mecflex Universal, 54 pieces in total, made up of the most used in the automotive and commercial vehicle sector measures.
- Kit includes our wall bracket code 2980001610.

Code	Description
2980001652	EXPO 5/N

Contenuto del kit			
Codice	Descrizione	Articolo	N° pezzi
2980002400	CX350	Tergi Wipermec 350 mm	2
2980002420	CX400	Tergi Wipermec 400 mm	2
2980002430	CX450	Tergi Wipermec 450 mm	4
2980002440	CX475	Tergi Wipermec 475 mm	2
2980002450	CX500	Tergi Wipermec 500 mm	4
2980002460	CX525	Tergi Wipermec 525 mm	2
2980002470	CX550	Tergi Wipermec 550 mm	6
2980002490	CX600	Tergi Wipermec 600 mm	2
2980002500	CX650	Tergi Wipermec 650 mm	2
2980002620	HD650	Tergi Wiper HD 650 mm	2
2980002630	HD700	Tergi Wiper HD 700 mm	2
2980002720	FU400	Tergi Mecflex Universal 400 mm	2
2980002730	FU425	Tergi Mecflex Universal 425 mm	2
2980002740	FU450	Tergi Mecflex Universal 450 mm	2
2980002750	FU475	Tergi Mecflex Universal 475 mm	2
2980002760	FU500	Tergi Mecflex Universal 500 mm	2
2980002770	FU530	Tergi Mecflex Universal 530 mm	2
2980002780	FU550	Tergi Mecflex Universal 550 mm	2
2980002790	FU575	Tergi Mecflex Universal 575 mm	2
2980002800	FU600	Tergi Mecflex Universal 600 mm	4
2980002810	FU625	Tergi Mecflex Universal 625 mm	4

## Universal mats for car pure rubber



- Adattabili su tutte le seguenti marche di auto:
- Alfa Romeo-Audi-Bmw-Citroen-Chrysler-Daewoo-Daihatsu-Fiat-Ford-Honda-Hyundai-Kia-Lancia-Mazda-Mitsubishi-Mercedes-Nissan-Opel-Peugeot-Renault-Rover-Saab-Seat-Suzuki-Subaru-Skoda-Toyota-Vw-Volvo.
- **Info tecniche**
- In pura gomma, presagomati per essere tagliati su misura.
- Con rilievi antiscivolo nella parte retro.
- Parte superiore con rilievi antiscivolo e antispurco.
- Battitacco completamente in gomma.
- 4 pezzi, 2 anteriori e 2 posteriori.

Code	Description
4440101580	255-tappeto auto tutta gomma

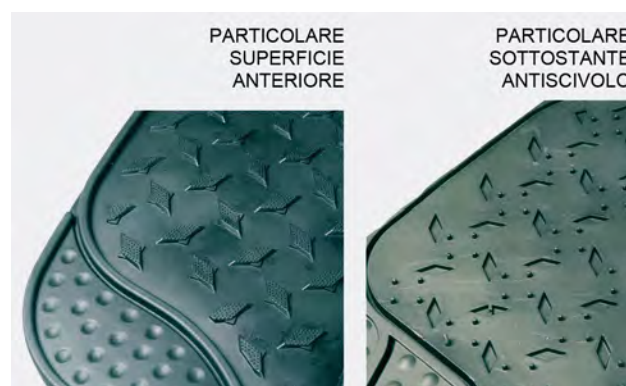

## Universal car mats pure rubber and carpet



- Adaptable on all the following car brands:
- alphaRomeo-Audi-Bmw-Citroen-Chrysler-Daewoo-Daihatsu-Fiat-Ford-Honda-Hyundai-Kia-Lancia-Mazda-Mitsubishi-Mercedes-Nissan-Opel-Peugeot-Renault-Rover-Saab-Seat-Suzuki-Subaru-Skoda-Toyota-Vw-Volvo.
- Technical info.
- In pure rubber and scuff carpet gray.
- Preformed to be cut to size.
- Anti-slip design on the back.
- Top with non-slip and dirt.
- 4 pieces, 2 front and 2 rear.

Code	Description
4440101582	256-rubber car mat and carpet





## Carpets Smart Fortwo



- In pure rubber in the upper part and in linen rubber in the lower part.
- With non-slip at the top.
- Sewing fabric edges.
- 2 pieces only front.

Code	Description
4440101584	257-car carpet Smart Fortwo

## Mats universal car in non-toxic pvc



- Adaptable to all types of cars thanks to the pre-cuts on the carpets
- Products with non-toxic material
- Compliant with European standards
- Easily washable
- Set consists of 4 pc
- Front measuring 45x70cm
- Rear measuring 43x45

Code	Description
4440101586	258-September 4 pz.universali car carpets



## Tappetini in PVC



- Caratteristiche:
- Materiale: PVC senza piombo.
- Misure: 230 x 370 mm.
- Modello a rombi a vaschetta.
- Peso 0,760 Kg.

Code	Description
4460006400	3996 - Neutro

## Set tappeti auto 4 pezzi



- Materiale fibra: 100% Polipropilene (PP).
- Retro: Polipropilene antiscivolo .
- Struttura superficie: "velour ad ago".
- Bordo del set: nero.
- Peso totale: 1400 grammi al metro quadro.
- Peso della fibra: 450 grammi al metro quadro.
- Colore tappeti: nero.

Code	Description
4440101290	195-mod.1 Neutro
4440101300	200-mod.2 Neutro
4440101350	210-mod.3 Neutro
4440101360	212-mod.4 Neutro

Personalizzazione a ricamo



Personalizzazione battitacco





## TAPPETI AUTO UNIVERSALI

CASA AUTOMOBILISTICA	GRUPPO 1M	GRUPPO 2M	GRUPPO 3M	GRUPPO 4M
<b>ALFA ROMEO</b>	155 - 33	MITO-GIULIETTA-GIULIA	75-145-146-147-156-164-166-159-GT	
<b>AUDI</b>	80-100-A2-A4-A6-A8<2001	Q3-Q5-Q7-A1-TT-A3-A4-A6-A8>2001	A3-A4-A5-A6>2003	
<b>BMW</b>		X1-S1-X3-X5-X6-S4		S3-S5-S7-Z4
<b>CITROEN</b>	AX-XANTIA-ZX-SAXO	DS5-NEMO-CCROSSER	BERLINGO-C1-C2-C3-C4PICASSO-DS3-DS4	C5-C6
<b>DACIA</b>		LODGY-DUSTER-DOKKER	LOGAN-SANDERO	
<b>FIAT</b>	PALIO-TEMPRA-TIPO-UNO-PANDA1-PUNTO1-MAREASTILO-IDEA	500-500L-500X-PANDA2/3-DOBLO'-QUBO-FREEMONT	PUNTO-16-MAREA-600-CROMA	
<b>FORD</b>	SIERRA-ESCORT-PUMAMONDEO1-FUSION-COUGAR	FIESTA-CMAX-SMAX-BMAX-KUGA-KA-FOCUS2010>	FIESTA-FOCUS<2005	
<b>HONDA</b>			ACCORD-CRV-HRV-JAZZ-CIVIC-FRV2001>	CIVIC-FRV<2001
<b>HYUNDAI</b>	ACCENT-COUPÉ-ELANTRA	ATOS-GETZ-I10-I20-IX20-I30-IX35-I40	MATRIX-SANTAMO-LANTRA-TUCSON-TRAJECT	GALLOPER-SANTA FE
<b>KIA</b>		CARENS-RIO-PICANTO-SPORTAGE2004>	RIO-SPORTAGE<2004-CEED-VENGA-SOUL	SORENTO
<b>LANCIA</b>	K-DELTA-LYBRA-THEMAY10	DELTA-MUSA-YPSILON2008>		
<b>LAND ROVER</b>			SPORT-VOGUE-FREELANDER-EVOQUE-DISCOVERY SPORT	DISCOVERY-DEFENDER
<b>MAZDA</b>	2-626-B2500	DEMIO-CX5-CX3-CX7	2-3-PREMACY	
<b>MERCEDES</b>		ML-CLA-GL-SMART FOR2-FOR4		A-B-C-E-CLK-SLK
<b>MINI</b>				ONE-COUNTRYMAN
<b>NISSAN</b>	TERRANO-XTRAIL-MURANO-PRIMERA	MICRA-NOTE-QUASQHAI		
<b>OPEL</b>	CALIBRA-VECTRA-INSIGNAZAFIRA-AGILA-OMEGA	CORSA-MERIVA-KARL	AGILA-ANTARA-ASTRA-MOKKA-ADAM	
<b>PEUGEOT</b>	106-205-306	2008-3008-4007-407-BIPPER-PARTNER	107-207-206-307-405	308-508
<b>RENAULT</b>	19-21-5	TWINGO-CLIO4-KANGOO-MEGANE-SCENIC	TWINGO-CLIO2-LAGUNA-MEGANE2	
<b>SEAT</b>	AROSA-ALTEA-IBIZA98-TOLEDO99	KOLEOS-MODUS-MEGANE-KADJAR-LEON-IBIZA-MII	IBIZA-LEON02	
<b>SUZUKI</b>	WAGONR-SJ-410-ALTO-IGNIS	SPLASH-SX4-SCROSS-VITARA15		VITARA-GRAN VITARA
<b>TOYOTA</b>	4RUNNER-LAND CRUISER	YARIS10-AYGO-IQ	COROLLA-PREVIA	YARIS99-RAV4-AVENSIS
<b>VOLKSWAGEN</b>	GOLF2-3-4-MAGGIOLINO-NEWBEATTLE-TUAREG	GOLF5-6-7-CADDY-TIGUAN-POLO-UP-TOURAN	POLO'00-PASSAT	
<b>VOLVO</b>	740-760-850-940-V50-S80-V70-C70	C30-V60-XC60-XC90	S40	V40





## Truck

Tachograph systems .....	pag. 1506	Spirals, joints and pipes .....	pag. 1569
Signage .....	pag. 1508	Fittings for braking and diesel systems .....	pag. 1575
Accident prevention and ADR .....	pag. 1528	Fissaggio per teloni .....	pag. 1590
Outdoor accessories .....	pag. 1531	Electrical equipment for vehicles .....	pag. 1602
Interior accessories .....	pag. 1538		

## Discs for chronotachygraph



- Chronotachygraph discs Meccanocar in wax paper.
- Designed for use with high precision.
- Approved for regulations.
- 100 piece packs, each, valid for 1 day per piece.



**OMOLOGAZIONI:**  
 03, 04, 07, 08, 09, 10,  
 11, 12, 15, 18, 21, 22,  
 23, 26, 29, 30, 31, 32,  
 35, 36, 37, 40, 41, 44,  
 45, 46, 47, 48, 53, 54,  
 55, 56, 57, 58, 59, 60,  
 63, 64, 65, 66, 67, 68,  
 69, 70, 72, 73, 74, 75,  
 78, 79, 80, 81, 82, 83.

Code	Desc.	Utilization
3680T00500	100 KM/H	LOW SPEED VEHICLES
3680T00600	125 KM/H	TRUCKS AND BUSES
3680T00700	140 KM/H	VANS
3680T00800	180 KM/H	VANS AND MINIBUS

## Kienzle tachograph charts 125km / h (125 to 24 EC 4K)



- Kienzle tachograph charts.
- Pack of 100 pcs. valid for 1 day per piece.
- Full scale 125 km / h.

**UTILIZZATO SUL 90% DEI MEZZI IN CIRCOLAZIONE**



**OMOLOGAZIONI:**  
 03,04,09,10,11,12,  
 15,18,21,22,23,26,  
 29,30,31,32,35,36,  
 37,40,41,44,45,46,  
 47,48,53,54,55,56,  
 57,58,59,60,63,64,  
 65,66,67,68,69,70,  
 72,73,74,75,82, 83.

Code	Desc.
3680T01100	125-24K



## Kienzle tachograph charts 125km / h (125 to 24/2 EC 4B)

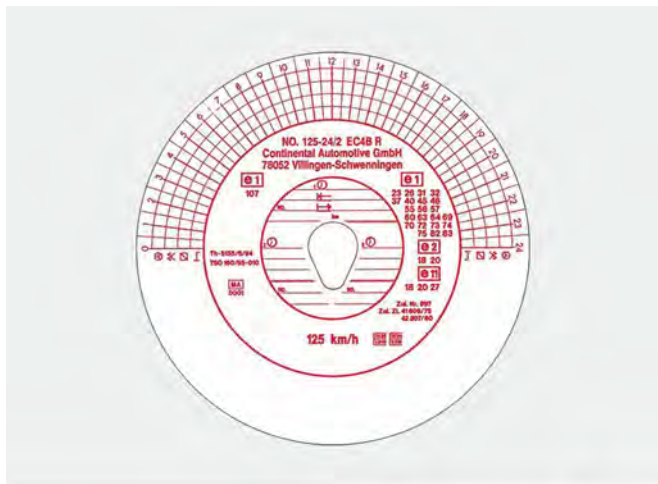

- Kienzle tachograph charts.
- Suitable for reading with scanner.
- Pack of 100 pcs. valid for 1 day per piece.
- Full scale 125 km / h.

Code	Desc.
3680T01110	125-24/2K



**OMOLOGAZIONI:**  
 23,26,31,32,37,40,  
 45,46,55,56,57,60,  
 63,64,69,70,72,73,  
 74, 75, 82, 83

## Paper for digital chronotachygraph



- Digital chronotachygraph paper rolls long 8m.
- Ideals and approved for equipment siemens vdo, actia, stoneridge.
- Products with special thermal paper resistant to temperature, UV and high humidity rates.
- A pack 3 pieces.



Code	Description
3680T01000	ROLL CHRONOTACHYGRAPH 3 PIECES

**ECE 70.00**

(normativa mezzi fino al 31/1/2010)

**ECE 70.01**

(normativa mezzi post 1/2/2010)

Esempio di applicazione per pannelli posteriori e laterali per motrici e rimorchi

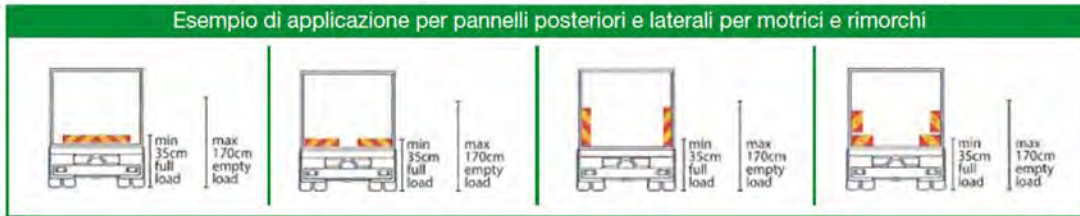
**Pannelli motrici ECE 70.00**

- Classe 2
- 2 pannelli spessore 1,0 mm in alluminio + ADESIVO
- Dimensione 565 x 132 mm

Code	Description
4460006200	3994

**Pannelli motrici ECE 70.01**

- Classe 3 (pellicola RINFRANGENTE/FLUORESCENTE)
- 2 pannelli spessore 1,0 mm in alluminio+adesivo
- Dimensione 565 x 132 mm

Code	Description
4460009130	4240 RF

**Pannelli motrici ECE 70.01**

- Classe 2 (pellicola RINFRANGENTE/RINFRANGENTE)
- 2 pannelli spessore 1,2 mm in alluminio COMPRESO ADESIVO
- Dimensione 565 x 132 mm

Code	Description
4460009135	4241 RR

## Pannelli rimorchio ECE 70.00

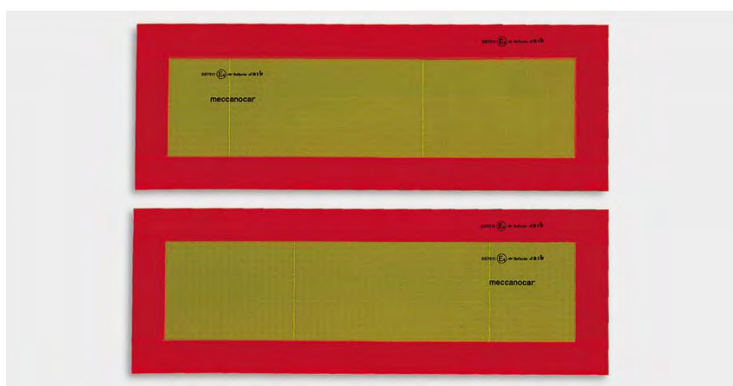

- Classe 2
- 2 pannelli spessore 1,0 mm in alluminio+ADESIVO
- Dimensione 565 x 196 mm
- Dimensioni 1130x196 singolo

Code	Description
4460006300	3995-565x196
4460006302	3995/2-1130x196

## Pannelli rimorchio ECE 70.01

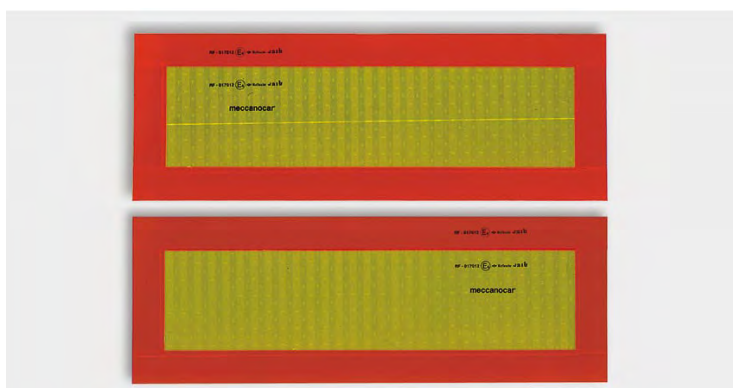

- Classe 3 (pellicola RINFRANGENTE/FLUORESCENTE)
- 2 pannelli spessore 1,0 mm in alluminio+ADESIVO
- Dimensione 565 x 196 mm

Code	Description
4460009140	4242 RF

## Pannelli rimorchio ECE 70.01

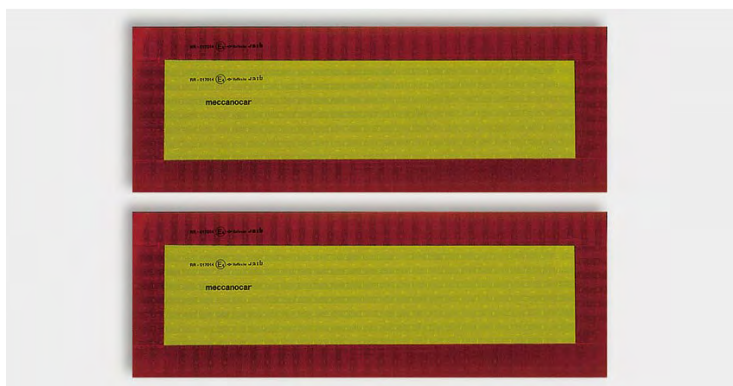

- Classe 2 (pellicola RINFRANGENTE/RINFRANGENTE)
- 2 pannelli spessore 1,2 mm in alluminio COMPRESO ADESIVO
- Dimensione 565 x 196 mm

Code	Description
4460009145	4243 RR

## Adesivi per motrici ECE 70.00



- Classe 2.
- 2 adesivi che possono essere attaccati direttamente su superfici.
- Dimensione 565 x 132 mm.
- **ATTENZIONE: PRODOTTO VALIDO SOLO PER L'ESTERO.**

Code	Description
4460006201	3994/1



## Adesivi per motrici ECE 70.01



- Classe 3 (RINFRANGENTE/FLUORESCENTE)
- 2 adesivi che possono essere attaccati direttamente su superfici
- Dimensione 565 x 132 mm
- **ATTENZIONE: PRODOTTO VALIDO SOLO PER L'ESTERO**

Code	Description
4460009131	4240/1 RF

## Adesivi per rimorchi ECE 70.01



Code	Description
4460009141	4242/1 RF

## Nastro retro-riflettente Reflexite ad elevata visibilità per la bordatura dei veicoli

- NASTRO DA APPLICARE POSTERIORMENTE E LATERALMENTE AI VEICOLI INDUSTRIALI PER LA BORDATURA LINEARE E DELLA SAGOMA
- NASTRO AUTOADESIVO CON PELLICOLA RETRO-RIFLETTENTE PER SUPERFICI RIGIDE E TELONATE
- ROTOLI DI NASTRO H 50 mm
- DISPONIBILE NEI COLORI: ROSSO - BIANCO - GIALLO

APPLICAZIONI	
Rosso	Bordatura posteriore
Giallo	Bordatura laterale e posteriore
Bianco	Bordatura laterale

**“I VEICOLI PROVISTI DI BORDATURA RETRO-RIFLETTENTE HANNO UNA MINOR PROBABILITÀ DEL 21% DI ESSERE COINVOLTI IN INCIDENTI NOTTURNI”**

- Conforme alle specifiche del regolamento ECE-ONU 104 e ECE 48 per superfici rigide
- Si riduce il numero di incidenti
- Si aumenta la sicurezza dei conducenti
- Elevata rifrangenza
- Visibile ad ampie angolazioni
- Si riducono i danni alle merci trasportate
- Si migliora l'immagine aziendale
- Facile da applicare
- Monostrato
- Disponibile per superfici rigide e telonate

## TAPE RETROREFLECTIVE ORAFOL FOR SOFT TOP SURFACES



- Orafol retro-reflective tape, for flow lorries exceeding 3.5 tonnes.
- Compliant and approved to UN-ECE 104 and ECE Regulation 48 for hard surfaces and soft top.
- It minimizes nr. of accidents.
- High reflectivity. Visible from wide angles.
- Easy to apply.
- Built on a single layer.
- adhesive side high adhesion power.

Bordatura obbligatoria

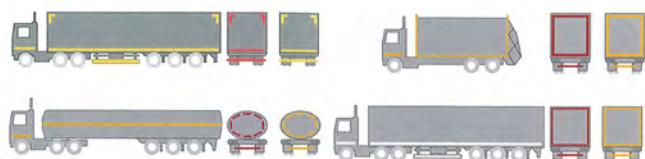

Code	Description	Confection
4460009182	4249/2 NAS.GIALLO ADESIVO TELONI ROT.	H 50 mm X 50 METRI
4460009183	4249/3 NAS.BIANCO ADESIVO TELONI ROT.	H 50 mm X 50 METRI
4460009184	4249/4 NAS.ROSSO ADESIVO TELONI ROT.	H 50 mm X 50 METRI
4460009185	4249/5 NAS.GIALLO ADESIVO TELONI ROT.	H 50 mm X 25 METRI
4460009186	4249/6 NAS.BIANCO ADESIVO TELONI ROT.	H 50 mm X 25 METRI
4460009187	4249/7 NAS.ROSSO ADESIVO TELONI ROT.	H 50 mm X 12,5 METRI
4460009165	4247 NASTRO ROSSO ADESIVO TELONI ROT.	H 50 mm X 25 METRI

## TAPE RETROREFLECTIVE ORAFOL FOR HARD SURFACES



- Adhesive tape for high visibility retro-reflective to the edging of the vehicles.

Code	Desc.	Color	Dimensions	Application
4460009150	4244	ROSSO	H50mmx25mt	SUPERFICI RIGIDE
4460009151	4244/1	ROSSO	H50mmx12,5mt	SUPERFICI RIGIDE
4460009155	4245	GIALLO	H50mmx50mt	SUPERFICI RIGIDE
4460009156	4245/1	GIALLO	H50mmx25mt	SUPERFICI RIGIDE
4460009160	4246	BIANCO	H50mmx50mt	SUPERFICI RIGIDE
4460009161	4246/1	BIANCO	H50mmx25mt	SUPERFICI RIGIDE

## TAPE SIGNAL OF SAFETY ECE-48 ECE-104 FOR HARD SURFACES AND TELONATE- 3M.



- Each box contains a roll of tape, instruction booklet and spatula to apply the tape.
- **Application guidelines:**
- The installed retroreflective materials may be formed by a single element or of several elements, as much as possible parallel to the ground and continuous.
- The mounting of the markings, must draw the entire length and width of the vehicle as possible.
- In the case of non-continuous strips, the separation can not exceed 50% of the shortest element length.
- They must be placed at least 25 cm from the ground and a maximum height of 1.5 m.
- Laterally you have to use yellow or white markers, while rear red or yellow.

Code	Description	Applications
4680001700	7165-Giallo 3M- rigido -L.50m X h.50mm	Per superfici rigide
4680001710	7168-BIANCO 3M- rigido -L.50 m X h.50mm	Per superfici rigide
4680001720	7167/S-Rosso 3M- rigido -L.12,5m X h.50mm	Per superfici rigide
4680001722	7167-Rosso 3M- rigido -L.50 m X h.50mm	Per superfici rigide
4680001730	7177-Giallo 3M- rigido -L.50m X h.50mm	Per autocisterne
4680001740	7178/S-Rosso 3M- rigido -L.12,5m X h.50mm	Per autocisterne
4680001750	7174-Giallo 3M- s.telonate -L.50m X h.50mm	Per superfici telonate
4680001760	7175-Bianco 3M- s.telonate-L.50m X h.50mm	Per superfici telonate
4680001770	7176/S-Rosso 3M- s.telonate -L.12,5m X h.50mm	Per superfici telonate

### Nastro retroriflettente AVERY per superfici rigide



- Nastro adesivo retro-riflettente ad elevata visibilità
- Conforme alla normativa ECE 104
- Fornito in rotoli H 50mm x 50m

Code	Description	Applications
4680002020	Nastro bianco Avery S.R. H50mmx50m	Superfici rigide
4680002030	Nastro giallo Avery S.R.H50mmx50m	Superfici rigide
4680002040	Nastro rosso Avery S.R.H50mmx50m	Superfici rigide





## Nastro retroriflettente AVERY per superfici telonate



- Nastro adesivo retro-riflettente ad elevata visibilità
- Conforme alla normativa ECE 104
- Fustellato per un incollaggio ottimale alla superficie
- Fornito in rotoli H 50mm x 50m

Code	Description	Applications
4680002050	Nastro bianco fust. Avery H50mmx50m	Superfici telonate
4680002060	Nastro rosso fust. Avery H50mmx50m	Superfici telonate
4680002070	Nastro giallo fust. Avery H50mmx50m	Superfici telonate



## PANNELLO TRASPORTO ECCEZIONALE



- Pannello posteriore
- Dimensione 600 x 150 mm
- Spessore 1,5 mm supporto alluminio

Code	Description
4460009190	4250



## PANNELLO LATERALE PER TRASPORTO ECCEZIONALE

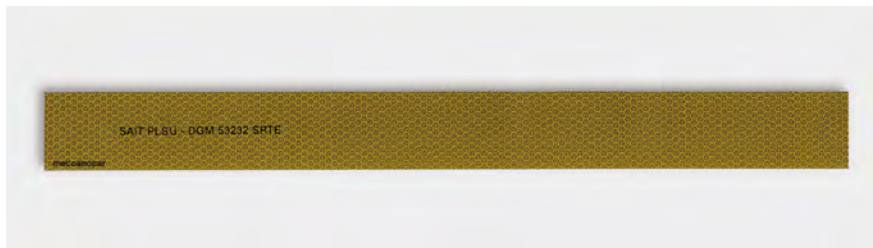

- Pannello laterale da applicare ogni 5 mt sulle fiancate del mezzo
- Dimensione 900 x 50 mm
- Spessore 1,5 mm supporto alluminio
- Classe 2

Code	Description
4460009195	4251

## PANNELLI ANTERIORE+POSTERIORE PER TRASPORTO ECCEZIONALE

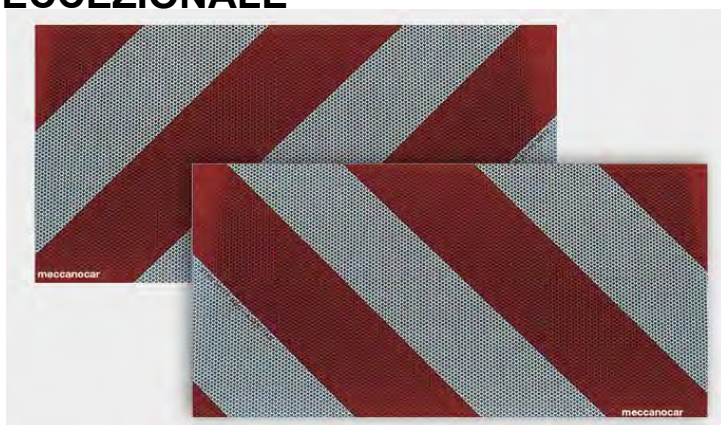

- 2 pannelli anteriore e posteriore per delimitazione sagoma mezzo
- Dimensione 600 x 300 mm
- Spessore 1,5 mm supporto alluminio
- Classe 2

Code	Description
4460009200	4252 kit

## Pannelli per carichi sporgenti



- dimensione 500 x 500 mm
- spessore 1,0 mm supporto alluminio
- classe 2
- con fori antitaglio, angoli arrotondati

Code	Description
4460007100	4008

## Bande per sponde idrauliche



- Banda da applicare su bordo sponde idrauliche.
- Da utilizzare con nostro codice 4460030020.
- Misure 25 x 41.

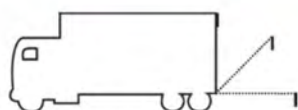

Code	Description
4460030025	31540DX
4460030030	31550SX

## Supporto per bande sponde idrauliche



- Supporto in alluminio per bande per sponde idrauliche.
- Da utilizzare con i nostri codici 4460030025 e 4460030030.

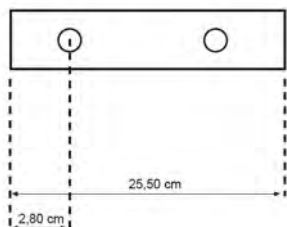

Code	Description
4460030020	31530

## Segnali adesivi di velocità per autoveicoli

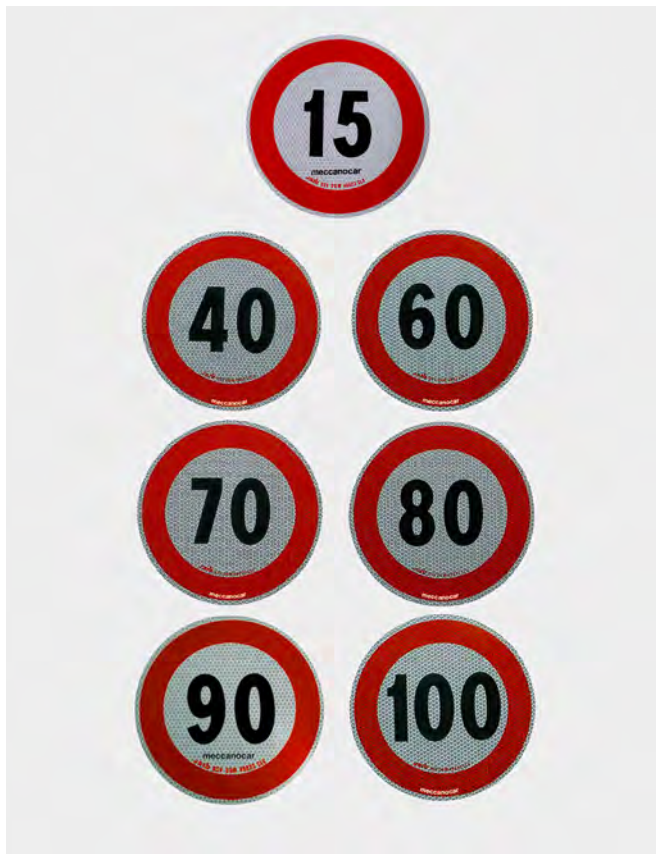

- Omologati dal ministero dei trasporti.
- Realizzati in pellicola rifrangente classe 2.
- Dischi adesivi diametro mm 200.
- Da applicare sulla parte posteriore del veicolo.
- **CARATTERISTICHE:**
- 15- 40 Macchine agrigole
- 40-60 Mezzi d'opera scarichi e a pieno carico
- 70-80 Autocarri con portata superiore a 120 Q.li
- 90 Veicoli est Europeo
- 80-100 Autocarri con portata fino a 120 Q.li

Code	Description
4460004840	3984 - 15
4460004850	3984 - 40
4460004900	3984 - 60
4460005000	3984 - 70
4460005100	3984 - 80
4460005200	3984 - 90
4460005210	3984 - 100
4460005212	Supporto all. D.200

## Pannelli agricoli



SCHEMA PER L'INSTALLAZIONE DEI PANNELLI

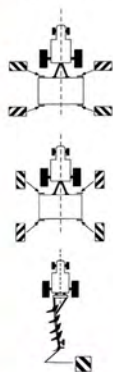

PER I PANNELLI MARCATI CON LA PAROLA "TOP" L'INSTALLAZIONE DOVRA' ESSERE TALE CHE LA PAROLA "TOP" RISULTI SUL LATO PIU' ALTO DEL PANNELLO

- Pannelli retroriflettenti e fluorescenti di segnalazione delle attrezzature portate o semiportate dalle trattrici agricole durante la circolazione su strada in ottemperanza al D.M. N. 391 del 19/06/1992.
- Pannelli in alluminio.
- Spessore 2 mm.

Code	Description	Dimensions
4460006900	4006	564x282
4460007000	4007	423x423

## Mark vehicle



- Adhesive labels to be applied on the front of the vehicle to identify in countries like Austria, Germany and Switzerland.
- Diameter 200 mm.

Code	Desc.	Significato simbolo	Country
4460030200	31810 - L	Silenced	Austria
4460030210	31815 - S	Silenziato	Germany
4460030220	31820 - G	Emission reduced	Austria
4460030230	31825 - U	Silenced / Emission reduced	Austria

## Film third parties

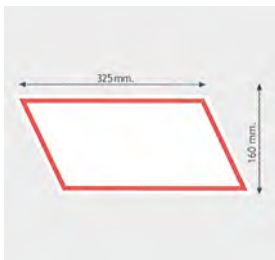

- White PVC adhesive film.
- Dimensions 325x160 mm.

Code	Desc.
4460004505	3980/B

## Film on their own

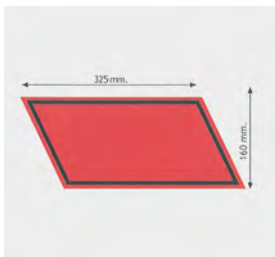

- Adhesive film PVC red.
- Dimensions 325x160 mm.

Code	Desc.
4460004500	3980/R



ESEMPI DI APPLICAZIONE A.D.R.

I seguenti disegni sono da considerarsi esclusivamente esempi

1 TRUCK - 1 MATERIAL / 1 MOTRICE - 1 MATERIALE  
1 VEHICULE - 1 MATIERE / 1 FAHRZEUG - 1 STOFF

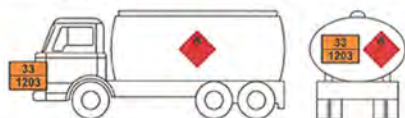

	Front Davanti Avant Vorne	Rear Dietro Arrière Hinten	Side Laterale Lateral Seiten
	33 1203	33 1203	◆
	◆	◆	◆

TRUCK + TRAILER - 1 MATERIAL / MOTRICE + RIMORCHIO - 1 MATERIALE  
2 VEHICULES - 1 MATIERE / FAHRZEUG + ANHÄNGER - 1 STOFF



	Front Davanti Avant Vorne	Rear Dietro Arrière Hinten	Side Laterale Lateral Seiten
	30 1202		◆
	◆	30 1202	◆

TRUCK + TRAILER - 2 MATERIALS / MOTRICE + RIMORCHIO - 2 MATERIALI  
2 VEHICULES - 2 MATIERES / FAHRZEUG + ANHÄNGER - 2 STOFF

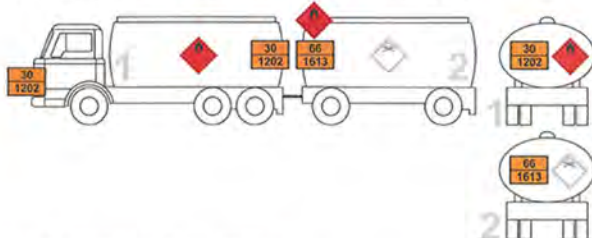

	Front Davanti Avant Vorne	Rear Dietro Arrière Hinten	Side Laterale Lateral Seiten
	30 1202	66 1613	◆
	30 1202	◆	◆
	◆	66 1613	◆

MORE MATERIALS / PIU' MATERIALI  
PLUSIEURES MATIERES / MEHRERE STOFFE



	Front Davanti Avant Vorne	Rear Dietro Arrière Hinten	Side Laterale Lateral Seiten
	Blank panels	85 1791	◆
	◆	◆	◆
	◆	◆	◆
	◆	◆	◆

1 TRUCK - 1 MATERIAL / 1 MOTRICE - 1 MATERIALE  
1 VEHICULE - 1 MATIERE / 1 FAHRZEUG - 1 STOFF



	Front Davanti Avant Vorne	Rear Dietro Arrière Hinten	Side Laterale Lateral Seiten
	33 1203	33 1203	◆

TRUCK + TRAILER - 1 MATERIAL / MOTRICE + RIMORCHIO - 1 MATERIALE  
2 VEHICULES - 1 MATIERE / FAHRZEUG + ANHÄNGER - 1 STOFF

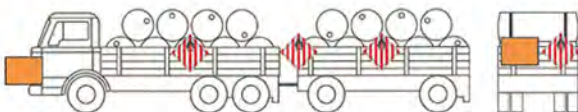

	Front Davanti Avant Vorne	Rear Dietro Arrière Hinten	Side Laterale Lateral Seiten
	33 1203		◆
	◆	33 1203	◆

TRUCK + TRAILER - 2 MATERIALS / MOTRICE + RIMORCHIO - 2 MATERIALI  
2 VEHICULES - 2 MATIERES / FAHRZEUG + ANHÄNGER - 2 STOFF

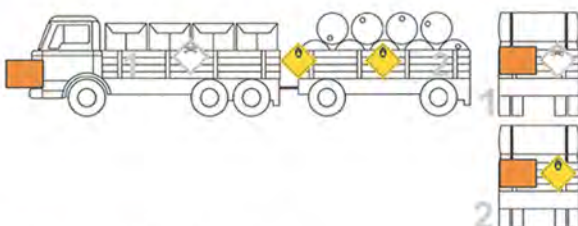

	Front Davanti Avant Vorne	Rear Dietro Arrière Hinten	Side Laterale Lateral Seiten
	33 1203		◆
	◆	33 1203	◆

MORE MATERIALS / PIU' MATERIALI  
PLUSIEURES MATIERES / MEHRERE STOFFE



	Front Davanti Avant Vorne	Rear Dietro Arrière Hinten	Side Laterale Lateral Seiten
	33 1203		◆
	◆	33 1203	◆

One panel each material

## PANNELLO A.D.R. IMBOSSATO PER MERCI PERICOLOSE



- Per applicazioni su veicoli con cisterna o per trasporto merci pericolose
- 400 mm x 300 mm
- Lamiera zincata spessore 0,8 mm

Code	Description	Tipo Sostanza
4460009225	4257	30-1202 GASOLIO
4460009230	4258	33-1203 BENZINA
4460009240	4260	23-1965 GPL

## Panels signaling "dangerous cargo" - STEEL HOLDER NUMBERS



- Fixed panels embossed to apply to vehicles with tank.
- Numbers for dimensions 70x118 mm.

Code	Desc.	Dimensions mm
4460009255	4263	400x300

## Embossed numbers 118x70 mm stainless



- Numbers to be included in the panel brings numbers art. ... 00 446 4263/4264.

RIPORTIAMO LE NUMERAZIONI PIÙ COMUNEMENTE UTILIZZATE	
TIPO	SOSTANZA
30-1202	GASOLIO
33-1203	BENZINA
30-1223	CHEROSENE
23-1965	GPL
23-1978	PROPANO LIQUIDO
23-1971	GAS NATURALE
22-1951	ARGON LIQUIDO
22-1977	AZOTO LIQUIDO
22-2187	BIOSSIDO DI CARBONIO
223-1966	IDROGENO LIQUIDO
225-1073	OSSIGENO LIQUIDO
236-1040	OSSIDO ETILENE
23-1011	BUTANO
223-1038	ETILENE REFRIGERATO
223-1972	GAS NATURALE LIQUIDO

Code	Desc.	N°
4460009265	4265 - 1	1
4460009270	4265 - 2	2
4460009275	4265 - 3	3
4460009280	4265 - 4	4
4460009285	4265 - 5	5
4460009290	4265 - 6	6
4460009295	4265 - 7	7
4460009300	4265 - 8	8
4460009305	4265 - 0	0
4460009310	4265 - X	X
4460009315	4265 - N	N

## Kit 10 pieces - Embossed figures 118x70 mm galvanized



- **CONTENTS:** PZ 0/2 - 1/1 PZ - PZ 2/2 - 3/3 PZ - N / 2 PZ.

Code	Desc.
4460009320	4266

## Kit 33 pieces - plasticized numbers 118x70 mm galvanized



- **CONTENTS:** PZ 0/3 - 1/3 PZ - PZ 2/3 - 3/4 PZ - PZ 4/2 - 5/3 PZ - PZ 6/5 - 7/2 PZ - PZ 8/3 - X / 2 PZ - N / 3 PZ.

Code	Desc.
4460009325	4267

## Heavy Goods Vehicle horizontal folding table



- Table 10/10 aluminum to be applied to the vehicle.

Code	Desc.	Dimensions mm
4460009335	4269	400x300

## PANNELLI A.D.R. PER MERCI PERICOLOSE



- Dimensione 400 x 300 mm
- Spessore 0,8 mm supporto lamiera zincata
- Classe 1
- Con fori antitaglio, angoli arrotondati

Code	Description
4460009205	4253

## LINING FOR PANEL FOR DANGEROUS GOODS



- Lining for the panel size 400 x 300 mm.
- Used to cover the panels when the vehicle does not carry dangerous goods.

Code	Description
4460009210	4254

## Pannello A.D.R. verticale per merci pericolose



Code	Description
4460009215	4255

## Pannello A.D.R. verticale ridotto per merci pericolose



Code	Description
4460030240	1830

## Pannello A.D.R. orizzontale per merci pericolose



Code	Description
4460009220	4256

## PANNELLO "R" RIFIUTI

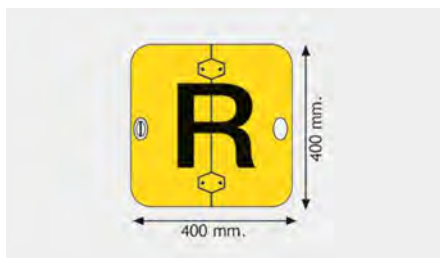

- Con supporto in alluminio pieghevole verticale
- Dimensioni 400x400mm
- Spessore 2 mm

Code	Desc.	Dimensions mm
4460042070	40X40X2 R	400x400



## CLIPS PICCOLA PER PANNELLI PIEGHEVOLI



- Fori mm 4 con interasse mm25
- L35X13 H 21mm

Code	Desc.
4460009328	CLIPS PICCOLA

## Fixing kit for stainless swivel plate holder



- The kit includes: 1 stainless bolt yourself, 1 hex nut steel, 1 washer stainless steel apron washer 1, 1 wing nut steel.
- The kit does not provide the hardware for the zipper.

Code	Desc.
3560401100	4335

## Repeater plate provisional double sided for trailers

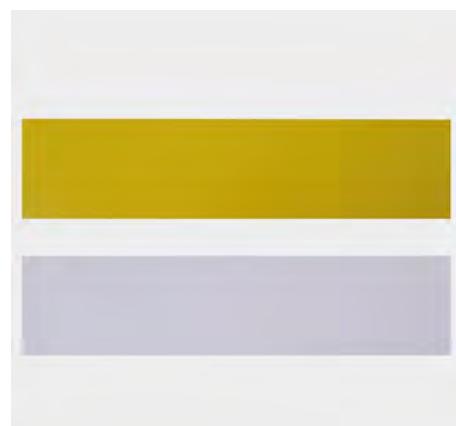

- Aluminum plaque 1 mm thick.
- For use with our license plate 4680000840.

Code	Desc.	Dimensions mm
4460030250	31840	480X115

## Holder spring plates for repeaters

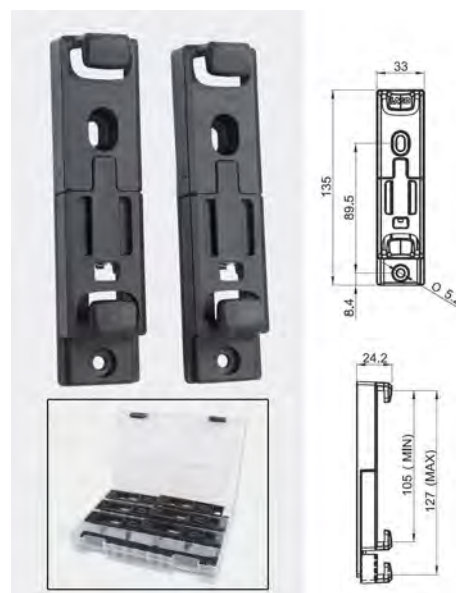

- Plate holder polypropylene for plates repeaters of industrial vehicles.
- Product suitable for drivers, VI dealerships, repair and body shops VI.
- Suitable for a steady attachment of license plates on trailers and semitrailers.
- Manufactured in plastic material gives greater convenience than traditional plate holder in steel.
- Equipped with beveled surfaces and polished that avoid that the operator can cut off during use.
- It allows the replacement of the plate in a few seconds.
- Weatherproof.
- The fixing can be effected with self-tapping screws or self-tapping max. 4.8 mm (eg. Fam.23300 or 15800).

Code	Desc.	Content
4680000850	170	2 pieces
4680000860	180	14 pieces in carrying case

## Steel swivel Plate holder



- Plate holder with hinge for repeater plate.
- Plate holder to apply to the vehicle by means of hardware.
- It allows fast and safe repeater plate.
- Dimensions 500x115 mm.

Code	Desc.
4680000840	1602

## Numbers and letters on plates repeaters



- Adhesive letters and numbers, to be used with our repeater plate 446 00 30250.
- Height 80 mm.

Code	Desc.
4460030255	31845 - 0
4460030260	31850 - 1
4460030265	31855 - 2
4460030270	31860 - 3
4460030275	31865 - 4
4460030280	31870 - 5
4460030285	31875 - 6
4460030290	31880 - 7
4460030295	31885 - 8
4460030300	31890 - 9
4460030310	31895 - A
4460030315	31900 - B
4460030320	31905 - C
4460030325	31910 - D
4460030330	31915 - E
4460030335	31920 - F
4460030340	31925 - G
4460030345	31930 - H
4460030350	31935 - I
4460030355	31940 - K
4460030360	31945 - L
4460030365	31950 - M
4460030370	31955 - N
4460030375	31960 - O
4460030380	31965 - P
4460030385	31970 - Q
4460030390	31975 - R
4460030395	31980 - S
4460030400	31985 - T
4460030405	31990 - U
4460030410	31995 - V
4460030415	32000 - Z
4460030420	32005 - X
4460030425	32010 - Y
4460030430	32015 - W
4460030435	32020 - J

### Adhesive letters - PERISHABLE FOODSTUFFS (a)



- Letter "a" sticker green background black writing.

Code	Desc.	Dimensione mm
4460009340	4270	500x400

### Adhesive letters - PERISHABLE FOODSTUFFS (d)



- Letter "d" sticker green background black writing.

Code	Desc.	Dimensione mm
4460009345	4271	500x400

### Adhesive letters - WASTE (R)



- "R" sticker yellow background black writing.

Code	Desc.	Dimensions mm
4460009350	4272	400x400
4460009352	4272/1	150x150

### ADHESIVE LABELS CL.2

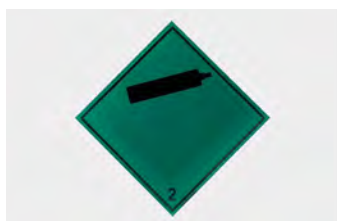

- CL. 2.
- Compressed gas not flammable.

Code	Description
4460009355	4273



- CL.3.
- Inflammabili.

Code	Description
4460009360	4274



- CL. 4.1.
- Flammable solids.

Code	Description
4460009365	4275



- CL. 4.2
- Spontaneously flammable substances.

Code	Description
4460009370	4276



- **CL. 4.3.**
- Evolution of flammable gas on contact with water.

Code	Description
4460009375	4277



- **Adesivo CL. 5.1**
- Oxidising, or organic peroxides.

Code	Description
4460009410	4284



- **Adesivo CL. 5.2**
- Comburenti o perossidi organici.
- Da applicare direttamente sul veicolo o su piastra in alluminio ns. cod. 446 00 09420-4286
- Dimensioni mm 300x300

Code	Description
4460009415	4285



- **CL. 6.1.**
- Toxic.

Code	Description
4460009385	4279



- **CL. 6.2.**
- Biological hazard.

Code	Description
4460009390	4280



- **CL. 8**
- Corrosive.

Code	Description
4460009395	4281

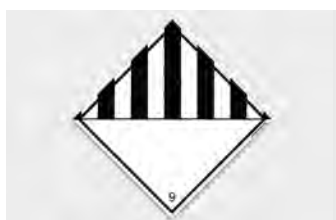

- **CL. 9.**
- Generic danger.

Code	Description
4460009400	4282



- **Adesivo CL. 9**
- With thermometer.

Code	Description
4460009405	4283



- **CL. 2**
- Inflammable.

Code	Description
4460009362	4274/1



- Materia pericolosa per l'ambiente.
- Da applicare direttamente sul veicolo o su piastra in alluminio ns. cod. 446 00 09420-4286
- Dimensioni mm 300x300

Code	Description
4460030035	31560





- Dangerous goods in quantity limited.

Code	Description
4460030040	31570



- CL 9A
- Pile o batterie a litio

Code	Description
4460042250	32376

## Accessories adhesive labels dim. 300x300 - 300x300 STICKERS ALUMINIUM PLATE 10/10 DOOR TO PLACARDS HOLDER

- Aluminum plate 10/10 door 300x300 adhesives for placards holders.

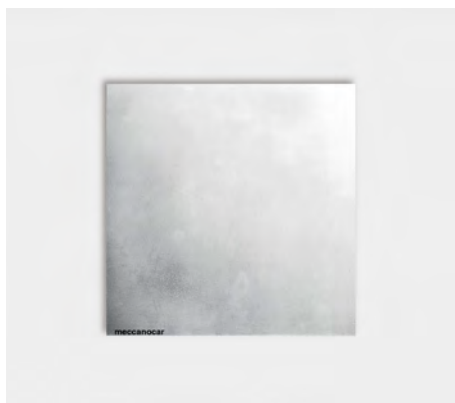

Code	Desc.
4460009420	4286

## ACCESSORI PER ETICHETTE ADESIVE DIM. 300X300 - PORTACARTELLO INOX DOPPIO 300X300 CON SUPPORTO



Code	Description
4460009435	4286

## ACCESSORI PER ETICHETTE ADESIVE DIM. 300X300 - SUPPORTO A SQUADRA INOX PER PORTACARTELLO

- Piastra alluminio 10/10 porta adesivi 300x300 per portacartelli.



Code	Description
4460009430	4288

## ACCESSORI PER ETICHETTE ADESIVE DIM. 300X300 - PORTACARTELLO INOX SEMPLICE 300X300

- Piastra alluminio 10/10 porta adesivi 300x300 per portacartelli.



Code	Description
4460009425	4287

## ADESIVI PER CASSONETTI PER RIFIUTI, SIA PVC SIA RINFRANGENTI



- Adesivi in pvc e in pvc rinfrangente classe 1 e 2 da apporre sui cassonetti per raccolta dei rifiuti misti e differenziati.
- Normativa art. 68 (art 25 Cod. della strada).

Code	Description	Dimensione mm	Material and class
4460009455	4293	200 x 400	PVC-classe 1
4460000604	7111	200 x 200	PVC-classe 1
4460000602	7109/MHI-kit 2 pcs dx+sx	100 x 400	PVC rinfrangente classe 2
4460000500	2170 DX	100 x 400	PVC rinfrangente-classe 1 destro
4460000600	2171 SX	100 x 400	PVC rinfrangente-classe 1 sinistro

## Bag A.D.R. standard composition



- The bag A.D.R. contains material for safety and signaling by the transport of dangerous goods by road, if there is an accident or spill material.
- NOTE: those who transport dangerous goods must have on board a purse ADR, and it is his task to integrate it with any items not contained, depending on the type of substance that is to carry.

### CONTENUTO BORSA ADR MECCANOCAR:

CODICE	DESCRIZIONE	Q.TÀ
4460002550	CONO IN PVC H.30	2
446000100	NASTRO DI SEGNALAZIONE BIANCO/ROSSO 200M	1
4460009500	LAMPADA CREPUSCOLARE ARANCIO CON INTERRUETTORE	2
4460008021	PILE PER LAMPADA CREPUSCOLARE ARANCIO	4
	COMPLETO GIACCA E PANTALONE IMPERMEABILE	1
4720008000	ELMETTO GIALLO DI SICUREZZA	1
4460027400	GUANTI PVC TG.10	1
47200033320	STIVALI IN PVC VERDI TG.43	1
4460009480	OCCHIALI A MASCHERINA	1
4460027905	LIQUIDO LAVA OCCHI	1
	FLACONE LAVA OCCHI	1
4460009485	BORSA ADR VUOTA	1

Code	Desc.	Characteristics
4460009460	4294	BAG A.D.R. STANDARD
4460009485	4299	BAG A.D.R. EMPTY

## Folding shovel spark



- Items to integrate bag A.D.R.

Code	Desc.
4460009465	4295

## Full face mask



- Article to supplement bag A.D.R.

Code	Desc.
4460009470	4296

## Filter full face mask



- Article to supplement bag A.D.R.
- Suitable for: gases, organic vapors, inorganic, sulfur dioxide, ammonia and derivatives, powders.

Code	Desc.
4460009475	4297

## Carpet manhole cover 60 x 70 cm



- Article to supplement bag A.D.R.

Code	Desc.
4460009495	4301

## Borsa A.D.R. composizione standard classe 1



- **Classe 1- 1.4 – 1.5 – 1.6 – 2.1 -2.2 -4.2 -5.1 -5.2 -6.2 – 7 A B C E**
- La borsa A.D.R. contiene materiale per la sicurezza e la segnalazione da parte del trasportatore di merci pericolose su strada, qualora si verifichi un incidente o fuoriuscita di materiale.
- N.B. chi fa trasporti di merci pericolose deve avere a bordo una borsa A.D.R., ed è suo compito integrarla con eventuali articoli non contenuti, a seconda del tipo di sostanza che va a trasportare
- **Per avere una borsa conforme alla classe 2.3 6.1** incrementare con maschera pieno facciale e filtro nostri codici 4460009470 e 4460009475
- **Per avere una borsa conforme alla classe 3- 4.1-4.3 -8-9,** incrementare con pala pieghevole antiscintilla cod.4460009465, tappeto copritombino cod.4460009495 e contenitore antiacido cod.4460042230.

Code	Description
4460042240	32375-BORSA ADR Classe 1

CONTENUTO		
CODICE	DESCRIZIONE	Q.TA'
4460009500	LAMPADA CREPUSCOLARE ARANCIO	2
4460008021	PILA PER LAMPADA CREPUSCOLARE	4
5120000080	TORCIA A BATTERIA ANTIDEFLAGRANTE	1
4460027905	FLACONE LAVACOCCHI	2
4460008955	GILET ARANCIO TG. UNICA	1
4460027400	GUANTO IN PVC	1
4460009480	OCCHIALI A MASCHERA	1
4460009485	4299- BORSA A.D.R. VUOTA	1



## Wedge chock block rules A.D.R.

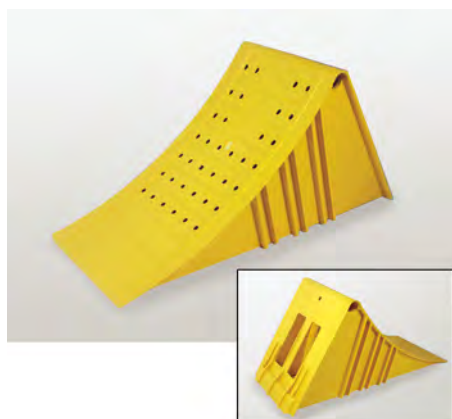

- Thermoplastic yellow.
- Complies with the new rules A.D.R.
- Complies with DIN 76051.
- Approved by TUV.
- Measurements: 494x200x230.
- Universal for all industrial vehicles.

Code	Description	Measures
4460010130	1870-53 wedge chock block	494X200X230



## Support wedge chock block



- Galvanized steel sheet support for wedge chock block 1870-53.
- Supplied without fasteners.

Code	Description
4460010140	Support 1871 x wedge 1870-53

## Absorbent material Kg. 1



- Article to supplement bag A.D.R.

Code	Desc.
4460009490	4300

## TORCIA ANTIDEFLAGRANTE



- Torcia antideflagrante (quando si accende e spegne , fornita di batterie
- Indispensabile in ambienti dove possano accumularsi prodotti infiammabili come interni di depositi e cisterne e dove una scintilla potrebbe creare un' esplosione.
- Monta n°4 stilo nostro codice 5120001020.

Code	Description
5120000080	80SL02-IP 68

## Portaestintori

### ESTRATTO NORMATIVA ADR 2011 CAPITOLO 8.1.4

OGNI UNITA' DI TRASPORTO TRASPORTANTE MERCI PERICOLOSE DEVE ESSERE MUNITA DI :  
ALMENO UN ESTINTORE PORTATILE DI CAPACITA MINIMA DI 2KG ( DA TENERSI SOLITAMENTE IN CABINA).  
UN NUMERO DI ESTINTORI PORTATILI DI CAPACITA TOTALE SECONDO LA MASSA DEL VEICOLO (VEDI FIGURA.1)



GLI ESTINTORI DEVONO ESSERE INSTALLATI A BORDO DELLE UNITA' DI TRASPORTO IN MODO CHE SIANO FACILMENTE ACCESSIBILI PER L'EQUIPAGGIO.  
PER LA LORO INSTALLAZIONE E' NECESSARIO L'UTILIZZO DI PORTAESTINTORI IN MODO CHE LE CAPACITA' OPERATIVE DEGLI ESTINTORI NON SIANO ALTERATE DAGLI EFFETTI CLIMATICI.

### Fire extinguisher holders in pvc extinguisher 6 kg



- Available in two colors: fully black or red.
- Direct application to the vehicle.
- Closing system practical and durable in all weather conditions and vibrations.

Code	Desc.	Color	L mm	H mm	P mm	Kg
4460009511	4304/1	BLACK	290	560	180	2,5
4460009512	4304/2	RED	290	560	180	2,5

### Fire extinguisher in Polypropylene for 6/9 kg fire extinguishers



- Fire extinguisher in Polypropylene for 6/9 kg fire extinguishers.
- Black with red cap.
- Direct application to the vehicle.

Code	Desc.	Color	L mm	H mm	P mm	Kg
4460009509	4304-6/9	Nero/rosso	330	670	260	4,2

## 9-12 kg Fire extinguisher holders in pvc lockable



- Color: black with red cap.
- Adaptable to Extinguishing 9 or 12 kg.
- Direct application to the vehicle.
- Practical closing and resistant to all weather and vibration.
- Reinforced inner and seal on the sealing cap.
- Opening locked with padlocks our cod. 470 00 03640 control slide extinguisher.

Code	Desc.	L mm	H mm	P mm	Kg
4460009513	4304/3 - 9/12 KG	340	780	240	5,9

## Powder extinguisher 6 Kg



- Model approved.
- Fire class 13A/89BC.
- Certificate of conformity and year of manufacture printed on the tank.
- Model indicated x drivers.

Code	Desc.	Height mm	Diameter mm	Weight Kg.
4460009514	4306/6	510	160	9,4

## Trumpet above cabin, stainless steel



- Compressed air horn in stainless steel.
- Powerful sound of 108 db.
- Universal, applicable to any of the truck equipped with compressed air.
- Can also be used for marine services in the construction has been made extensive use of precious metals such as stainless steel for croissant, Zama to stand, phosphor bronze for membrane. In order to ensure a large margin of safety, durability and corrosion resistance.
- Available in two lengths: 60cm / 65cm.
- It works with pressure from 4 to 20 ATM.
- Conforms to current regulations.
- Applicable in pairs to have bitonality.
- Weight: 1400 g.



Code	Description	Length	Photo
4680000100	40- stainless steel Horn 60 cm	60 cm	1
4680000110	41-stainless steel Horn 65 cm	65 cm	-
4680000140	44-Solenoid valve 24V	-	2

## Two tone horn



- Warning bitonal black.
- Powerful sound from 110 Db.
- Audibility 200-300 meters.
- Operating pressure 6-12 atm.
- Applicable on any vehicle with compressed air.
- Conforms to current regulations with spoiler to prevent the intrusion of insects and condensation.

Code	Description	Power
4680000130	43- Warning bitonal	110 db
4680000140	44- Solenoid valve 24V	-

## Trumpet under cabin



- Horn alloy with compressed air solenoid valve.
- Powerful sound from 108 Db.
- Audibility 200-300 meters.
- Operating pressure 6-12 atm. 24V.
- Applicable on any vehicle with compressed air.
- Product compliant with local regulations.
- The ease of installation of all heavy goods vehicles makes a trumpet industry leader.

Code	Description	Power
4680000120	42-Horn with solenoid	108db



## Electric horn 24V - 400Hz



- Electric horn when running on 24 Volts, the sound frequency of 400 Hz. Construction steel, supplied with mounting bracket with hole diameter 9 mm.
- Electrical connections via faston pitch 6.3 mm. Can be installed under the cabin, engine compartment, wheel arches, etc.
- Dimensions: diameter 112 mm, maximum thickness 56 mm.



Code	Desc.
4680000150	44/1

## Ring hubcap 10 holes steel



- Stainless steel ring 10 holes.
- Allowing ventilation of the hub.
- Quick and easy installation.
- Brackets incorporated for fastening.
- Height 425 mm wheelbase 335 mm.
- For wheels 22.5".
- Weight 1,400 gr.
- Bracket holes from 23 mm.
- 45-ring hubcap 10 holes steel.

Code	Description
4680000200	45-Anello coprimozzo 10 fori inox

## Hard hubcap 10 holes steel



- Cup stainless steel 10 holes.
- Brackets incorporated for fastening.
- Quick and easy installation.
- Height 425 mm wheelbase 335 mm.
- For wheels 22.5".
- Weight 1,480 gr.
- Bracket holes from 23 mm.

Code	Description
468000210	46-disc hubcap 10 holes steel

## Bolt caps chrome wheels for trucks



- Bolt caps in chromed plastic material for wheels of industrial vehicles.
- Available for bolts 32 mm - 33 mm.
- As well as an aesthetic fulfill the task of protecting the bolts from weather and dirt.

Code	Desc.	Characteristics
4460009620	4310-32	Bolt caps 32mm
4460009625	4310-33	Bolt caps 33 mm

## Checkpoint® - The original indicators tightening



- Driving safety of heavy vehicles, whether they are dedicated to the transport of goods, persons, dangerous goods, etc.. It is very important. The Checkpoint Safety has conceived of simple indicators to be applied on the wheel nuts of such means, immediately visible and arranged to indicate quickly if one or more of these loosens compromising safety. Also it speeds up enormously the security checks carried out on vehicles with high mileage and on public transport.
- Keep tightening the wheel nuts, in addition to avoiding the separation of the same, avoids damage to the nuts, studs and especially circles, avoiding costs for the restoration of the wheel assembly. Indicators are also required in some states for those carrying dangerous goods.
- The range includes various models, in size and in the most popular colors. The material with which they are constructed makes them stable and safe over time, resistant to weather, salt spilled on the streets in winter, at temperatures up to + 125 ° C.



### Checkpoint

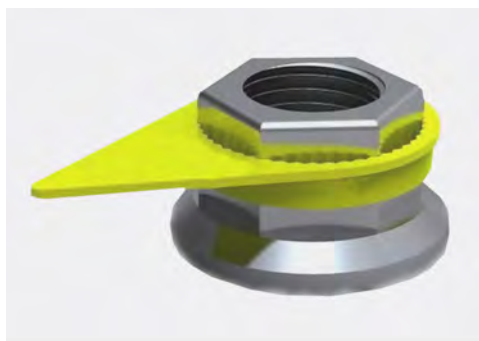

- The simplest model but equally effective indicators tightening Checkpoint®. It simply inserts the wheel nuts following a precise pattern decided by the installer. The displacement of the tip of the bar indicates the loosening of the nut, and then the loss of security.
- Available in two colors, to suit the personal tastes of the user, and in the two most commonly used measures of dice.
- The measure of the Checkpoint is related to the aperture size of the key that is necessary for the assembly and disassembly of the wheel nuts.

Code	Desc.	Measure mm	Color
4680001510	350-33GF	33	Fluorescent yellow
4680001520	350-32RV	32	Bright red
4680001530	350-33RV	33	Rosso vivo

## Dustite



- Destiny combines the action of the clamping indicator to those of dust cap and aesthetic finish. It fits perfectly on the wheel nuts remaining in solidarity with them and long-lasting. The displacement of the tip of the bar indicates the loosening of the nut, and then the loss of security.
- Available in three colors, to suit the personal tastes of the user, and in the two most commonly used measures of dice.
- The measure of Dustite refers to the measure of the opening of the key that is necessary for the assembly and disassembly of the wheel nuts.

Code	Desc.	Measure mm	Color
4680001540	360-32GR	32	Silver gray
4680001550	360-33GR	33	Silver gray
4680001560	360-32NE	32	Black
4680001570	360-33NE	33	Black
4680001580	360-32RV	32	Bright red
4680001590	360-33RV	33	Bright red

## Dustite LR



- The Dustite LR is designed for the use of the model Dustite where there are wheel covers with access holes wheel nuts. It combines the action of the clamping indicator to those of dust cap and aesthetic finish. It fits perfectly on the wheel nuts remaining in solidarity with them and long-lasting. The displacement of the tip of the bar indicates the loosening of the nut, and then the loss of security.
- Available in three colors, to suit the personal tastes of the user, and in the two most commonly used measures of dice.
- The measure of Dustite LR refers to the measure of the opening of the key that is necessary for the assembly and disassembly of the wheel nuts.

Code	Desc.	Measure mm	Color
4680001600	370-32GR	32	Silver gray
4680001610	370-33GR	33	Silver gray
4680001620	370-32NE	32	Black
4680001630	370-33NE	33	Black
4680001640	370-32RV	32	Bright red
4680001650	370-33RV	33	Bright red
4680001660	370-32 GF	32	Fluorescent yellow
4680001670	370-33 GF	33	Fluorescent yellow



## Universal linings for vans



COLORI DISPONIBILI:



Code	Description	Color
4440001495	12505 Cover van	Grey
4440001505	12515 Cover van	Blue
4440001515	12525 Cover van	Black

### Adaptability:

- Citroën Jumpy until 2006.
- Citroën Jumpy until 2001.
- Fiat Scudo until 2006.
- Fiat Ducato until 2001.
- Ford Transit until 2000.
- Iveco Daily until 2005 and from 2006 to 2013
- Mercedes Sprinter up to 2005.
- Mercedes Vito until 2003.
- Nissan Trade.
- Opel Movano until 2002.
- Peugeot Expert until 2006.
- Peugeot Boxer until 2001.
- Renault Trafic up to 2000.
- Renault Master until 2002.
- Renault Mascott until 2002.
- Toyota Hiace 1995.
- Volkswagen Transporter until 2002.
- Volkswagen Lt 1996-2002.
- and commercial vehicles alike not mentioned.
- Composition: cotton blend.
- Ideal for all seasons.
- Washable at 30 ° C.
- Set consists of: 1 seat - 1 bench - 3 headrests.

## Universal linings for vans



COLORI DISPONIBILI:

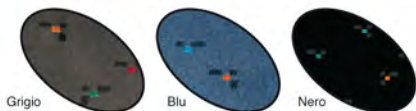

Code	Description	Color
4440004000	16000 Cover van	Grey
4440004010	16010 Fodera furgone	Blu
4440004020	16020 Fodera furgone	Nero

- Adaptability: Ford Transit from 2001 to 2005 and from 2006.
- Composition: cotton blend.
- Ideal for all seasons.
- Washable at 30°C.
- Set consists of: 1 seat - 1 bench.

## Universal linings for vans



COLORI DISPONIBILI:

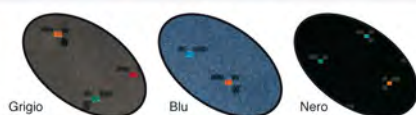

Code	Description	Color
4440004030	16030 Cover van	Grey
4440004040	16040 Fodera furgone	Blu
4440004050	16050 Fodera furgone	Nero

### Adaptability:

- **Nissan Primastar - since 2001.**
- **Opel Vivaro - since 2001.**
- **Renault Trafic - 2001.**
- Composition: cotton blend.
- Ideal for all seasons.
- Washable at 30 ° C.
- Set consists of: 1 seat - 1 bench - 3 headrests.

## Universal linings for vans



COLORI DISPONIBILI:

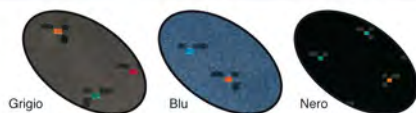

Code	Description	Color
4440004060	16060 Cover van	Grey
4440004070	16070 Cover van	Blue
4440004080	16080 Cover van	Black

### Adaptability:

- **Citroën Jumper to 2017**
- **Fiat Ducato.**
- **Peugeot Boxer.**
- **FROM 2002 TO 2005, and since 2006.**
- Composition: cotton blend.
- Ideal for all seasons.
- Washable at 30 ° C.
- Set consists of: 1 seat - 1 bench - 3 headrests.

## Universal linings for vans



**COLORI DISPONIBILI:**

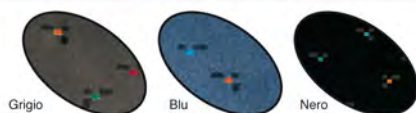

Code	Description	Color
4440004090	16090 Cover van	Grey
4440004100	16100 Cover van	Blue
4440004110	16110 Cover van	Black

### Adaptability:

- Nissan Interstar - SINCE 2003.
- Opel Movano - IN 2003.
- Renault Mascott - SINCE 2003.
- Renault Master - SINCE 2003.
- Composition: cotton blend.
- Ideal for all seasons.
- Washable at 30 ° C.
- Set consists of: 1 seat - 1 bench - 3 headrests.

## Universal linings for vans



**COLORI DISPONIBILI:**

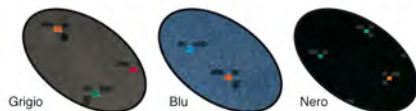

Code	Description	Color
4440004120	16120 Cover van	Grey
4440004130	16130 Cover van	Blue
4440004140	16140 Cover van	Black

### Adaptability:

- Citroen Jumpy - SINCE 2007.
- Fiat Scudo - SINCE 2007.
- Peugeot Expert - SINCE 2007.
- Composition: cotton blend. Ideal for all seasons.
- Washable at 30°C.
- Set consists of: 1 seat - 1 bench - 3 headrests.



## Covers Iveco Eurocargo



COLORI DISPONIBILI:

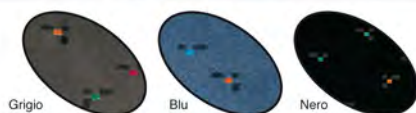

- Adaptability: **IVECO EUROCARGO FROM 1999 TO 2007.**
- Composition: cotton blend.
- Ideal for all seasons.
- Washable at 30 ° C.
- Set consists of: 1 driver's seat - one seat passenger side - 2 back side passengers - 3 headrests.

Code	Description	Color
4440004150	16150 Cover Eurocargo	Grey
4440004160	16160 Cover Eurocargo	Black
4440004170	16170 Cover Eurocargo	Blue

## Fodere universali per camion mod. TOP



- Fodere con marchio della casa costruttrice.
- Adattabili: Iveco Stralis; Man Tga; Mercedes Actros e Axor.
- **I PARTICOLARI FANNO LA DIFFERENZA:**
- Adattabili a sedili con o senza cintura di sicurezza.
- Adattabili a sedili con o senza bracciolo.
- Disponibili in tre colori
- Composizione: cotone-poliuretano-maglina

Code	Description	Color
4440001252	11722-FODERA TOP STRALIS GRIG	GRIGIO
4440001254	11724-FODERA TOP STRALIS BLU	BLU
4440001256	11726-FODERA TOP STRALIS NERO	NERO
4440001258	11728-FODERA TOP M.TGA GRIG	GRIGIO
4440001260	11730-FODERA TOP M.TGA BLU	BLU
4440001262	11732-FODERA TOP M.TGA NERO	NERO
4440001264	11734-FOD.TOP ACTROS AXOR GR	GRIGIO
4440001266	11736-FOD.TOP ACTROS AXOR BLU	BLU
4440001268	11738-FOD.TOP ACTROS AXOR NER	NERO



## Fodere universali per camion mod. TURBO



**COLORI DISPONIBILI:**

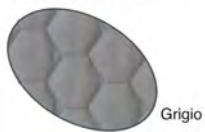

- Adattabili: Iveco Stralis; Man Tga; Mercedes Actros e Axor.
- **I PARTICOLARI FANNO LA DIFFERENZA:**
- Adattabili a sedili con o senza cintura di sicurezza.
- Adattabili a sedili con o senza bracciolo.
- Disponibili in tre colori
- Composizione: cotone-poliuretano-maglina

Code	Description	Color
4440001472	11422-FOD. TURBO STRALIS GRIG	GREY
4440001474	11424-FOD. TURBO STRALIS BLU	BLU
4440001476	11426-FOD. TURBO STRALIS NERO	NERO
4440001478	11428-FOD. TURBO M.TGA GRIG	GREY
4440001480	11430-FOD. TURBO M.TGA BLU	BLU
4440001482	11432-FOD. TURBO M.TGA NERO	NERO
4440001484	11434-FOD.TURBO ACTROS AXOR GR	GRIGIO
4440001486	11436-FOD.TURBO ACTROS AXOR BLU	BLU
4440001488	11438-FOD.TURBO ACTROS AXOR NER	NERO

## FODERE CAMION



### Colori standard



Grigio 01



Blu 03

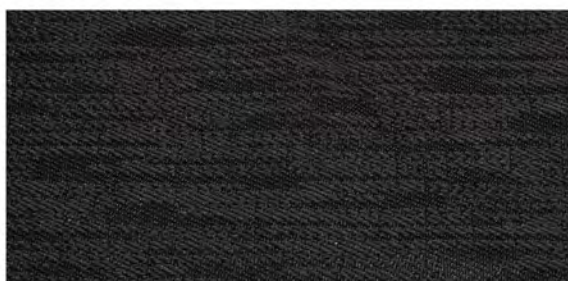

Nero 04

- Fodere realizzate interamente in cotone + poliestere di ottima qualità
- Fodere nei colori originali in poliestere 100%
- Finiture accurate
- Prodotto completamente Italiano

### DAF XF 95



Code	Desc.	Seats	Headrest	Belt <i>integrated</i>	Characteristics	Color
4440004300	201	1+1	Integrato	Si	2 sedili uguali	Grigio 01
4440004310	203	1+1	Integrato	Si	2 sedili uguali	Blu 03
4440004320	204	1+1	Integrato	Si	2 sedili uguali	Nero 04

### DAF XF105



Code	Desc.	Seats	Headrest	Belt <i>integrated</i>	Characteristics	Color
4440004330	301	1+1	Integrato	Si	2 sedili uguali guida con bracciolo	Grigio 01
4440004340	303	1+1	Integrato	Si	2 sedili uguali guida con bracciolo	Blu 03
4440004350	304	1+1	Integrato	Si	2 sedili uguali guida con bracciolo	Nero 04

## DAF XF 105 EURO 5/6 DAL 2014



Code	Desc.	Seats	Headrest	Belt <i>integrated</i>	Characteristics	Color
4440004470	401	1+1	Integrato	Si	2 sedili uguali	Grigio 01
4440004480	403	1+1	Integrato	Si	2 sedili uguali	Blu 03
4440004490	404	1+1	Integrato	Si	2 sedili uguali	Nero 04

## DAF CF



Code	Desc.	Seats	Headrest	Belt <i>integrated</i>	Characteristics	Color
4440004500	501	1+1	Integrato	Si	2 sedili uguali	Grigio 01
4440004510	503	1+1	Integrato	Si	2 sedili uguali	Blu 03
4440004520	504	1+1	Integrato	Si	2 sedili uguali	Nero 04

## IVECO STRALIS

**Originali**

Originale Rosso



Originale virgole blu



Originale virgole Grigio

Code	Desc.	Seats	Headrest	Belt <i>integrated</i>	Characteristics	Color
4440004560	801	1+1	Integrato	Si	2 sedili uguali	Grigio 01
4440004570	803	1+1	Integrato	Si	2 sedili uguali	Blu 03
4440004580	804	1+1	Integrato	Si	2 sedili uguali	Nero 04
4440004590	874	1+1	Integrato	Si	2 sedili uguali	Originale Rosso
4440004600	875	1+1	Integrato	Si	2 sedili uguali	Originale virgole blu
4440004610	876	1+1	Integrato	Si	2 sedili uguali	Originale virgole grigio

## IVECO STRALIS EURO 6

**Originali**

Originale Beige bicolore



Originale Nero

Code	Desc.	Seats	Headrest	Belt <i>integrated</i>	Characteristics	Color
4440004620	901	1+1	Integrato	Si	2 sedili uguali - con 3 braccioli	Grigio 01
4440004630	903	1+1	Integrato	Si	2 sedili uguali - con 3 braccioli	Blu 03
4440004640	904	1+1	Integrato	Si	2 sedili uguali - con 3 braccioli	Nero 04
4440004650	905	1+1	Integrato	Si	2 sedili uguali - con 3 braccioli	Originale beige bicolore
4440004660	906	1+1	Integrato	Si	2 sedili uguali - con 3 braccioli	Originale nero



## IVECO TRAKKER



Originali



Originale Rosso

Code	Desc.	Seats	Headrest	Belt <i>integrated</i>	Characteristics	Color
4440004660	1001	1+1	Integrato	Si	2 sedili uguali	Grigio 01
4440004670	1003	1+1	Integrato	Si	2 sedili uguali	Blu 03
4440004680	1004	1+1	Integrato	Si	2 sedili uguali	Nero 04
4440004690	1005	1+1	Integrato	Si	2 sedili uguali	Originale rosso

## IVECO EUROTECH/EUROSTAR/EUROTRAKKER



Originali



Originale Grigio a righe

Code	Desc.	Seats	Headrest	Belt <i>integrated</i>	Characteristics	Color
4440004700	1101	1+1	Staccato	Si	2 sedili uguali	Grigio 01
4440004710	1103	1+1	Staccato	Si	2 sedili uguali	Blu 03
4440004720	1104	1+1	Staccato	Si	2 sedili uguali	Nero 04
4440004730	1158	1+1	Staccato	Si	2 sedili uguali	Originale grigio e righe

## IVECO EUROTECH /EUROTRAKKER CURSOR



Originali



Originale Grigio e viola

Code	Desc.	Seats	Headrest	Belt <i>integrated</i>	Characteristics	Color
4440004740	1201	1+1	Staccato	Si-guida	Sedili diversi cintura solo su guida	Grigio 01
4440004750	1203	1+1	Staccato	Si-guida	Sedili diversi cintura solo su guida	Blu 03
4440004760	1204	1+1	Staccato	Si-guida	Sedili diversi cintura solo su guida	Nero 04
4440004770	1257	1+1	Staccato	Si-guida	Sedili diversi cintura solo su guida	Originale grigio e viola

## IVECO TURBOSTAR



Code	Desc.	Seats	Headrest	Belt <i>integrated</i>	Characteristics	Color
4440004780	1301	1+1	Staccato	No	2 sedili uguali	Grigio 01
4440004790	1303	1+1	Staccato	No	2 sedili uguali	Blu 03
4440004800	1304	1+1	Staccato	No	2 sedili uguali	Nero 04



## IVECO EUROCARGO I SERIE 2 POSTI



Code	Desc.	Seats	Headrest	Belt <i>integrated</i>	Characteristics	Color
4440004840	1501	1+1	Si-guida	Si	2 sedili diversi - cintura su guida	Grigio 01
4440004850	1503	1+1	Si-guida	Si	2 sedili diversi - cintura su guida	Blu 03
4440004860	1504	1+1	Si-guida	Si	2 sedili diversi - cintura su guida	Nero 04

## IVECO EUROCARGO I SERIE 3 POSTI



Code	Desc.	Seats	Headrest	Belt <i>integrated</i>	Characteristics	Color
4440004900	1701	1+2	Si-guida	Si	Guida + panca 2 posti	Grigio 01
4440004910	1703	1+2	Si-guida	Si	Guida + panca 2 posti	Blu 03
4440004920	1704	1+2	Si-guida	Si	Guida + panca 2 posti	Nero 04

## IVECO EUROCARGO TECTOR 2 POSTI

**Originali**

Originale Rosso/blu



Originale rombi azzurro

Code	Desc.	Seats	Headrest	Belt <i>integrated</i>	Characteristics	Color
4440004930	1801	1+1	Staccato	Si-guida	2 sedili diversi cintura solo su guida	Grigio 01
4440004940	1803	1+1	Staccato	Si-guida	2 sedili diversi cintura solo su guida	Blu 03
4440004950	1804	1+1	Staccato	Si-guida	2 sedili diversi cintura solo su guida	Nero 04
4440004960	1859	1+1	Staccato	Si-guida	2 sedili diversi cintura solo su guida	Originale rombi azzurro
4440004970	1860	1+1	Staccato	Si-guida	2 sedili diversi cintura solo su guida	Originale rosso/blu

## IVECO EUROCARGO TECTOR 3 POSTI

**Originali**

Originale Rosso/blu

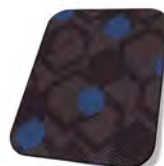

Originale rombi azzurro

Code	Desc.	Seats	Headrest	Belt <i>integrated</i>	Characteristics	Color
4440004980	1901	1+2	Staccato	Si-guida	panca 2 posti (schienali divisi)	Grigio 01
4440004990	1903	1+2	Staccato	Si-guida	panca 2 posti (schienali divisi)	Blu 03
4440005000	1904	1+2	Staccato	Si-guida	panca 2 posti (schienali divisi)	Nero 04
4440005020	1906	1+2	Staccato	Si-guida	panca 2 posti (schienali divisi)	Originale rosso/blu
4440005010	1959	1+2	Staccato	Si-guida	panca 2 posti (schienali divisi)	Originale rombi azzurro

## IVECO EUROCARGO TECTOR DAL 2008 2 POSTI



Originali



Originale Nero

Code	Desc.	Seats	Headrest	Belt <i>integrated</i>	Characteristics	Color
4440005080	2101	1+1	Integrato	Si	2 sedili uguali	Grigio 01
4440005090	2103	1+1	Integrato	Si	2 sedili uguali	Blu 03
4440005100	2104	1+1	Integrato	Si	2 sedili uguali	Nero 04
4440005110	2173	1+1	Integrato	Si	2 sedili uguali	Originale nero

## IVECO EUROCARGO TECTOR DAL 2008 3 POSTI



Originali



Originale Nero

Code	Desc.	Seats	Headrest	Belt <i>integrated</i>	Characteristics	Color
4440005030	2001	1+2	Integrato	Si-guida	Panca 2 posti (schienali divisi)	Grigio 01
4440005040	2003	1+2	Integrato	Si-guida	Panca 2 posti (schienali divisi)	Blu 03
4440005050	2005	1+2	Integrato	Si-guida	Panca 2 posti (schienali divisi)	Nero 04
4440005060	2005	1+2	Integrato	Si-guida	Panca 2 posti (schienali divisi)	originale nero

## MAN TGA XXL



Code	Desc.	Seats	Headrest	Belt <i>integrated</i>	Characteristics	Color
4440005220	2501	1+1	Integrato	Si	2 sedili uguali	Grigio 01
4440005230	2503	1+1	Integrato	Si	2 sedili uguali	Blu 03
4440005240	2504	1+1	Integrato	Si	2 sedili uguali	Nero 04

## MAN TGA-TGL-TGS



Code	Desc.	Seats	Headrest	Belt <i>integrated</i>	Characteristics	Color
4440005250	2601	1+1	Integrato	Si-guida	Sedili diversi cintura solo su guida	Grigio 01
4440005260	2603	1+1	Integrato	Si-guida	Sedili diversi cintura solo su guida	Blu 03
4440005270	2604	1+1	Integrato	Si-guida	Sedili diversi cintura solo su guida	Nero 04

## MAN TGX



Code	Desc.	Seats	Headrest	Belt <i>integrated</i>	Characteristics	Color
4440005280	2701	1+1	Integrato	Si-guida	Sedili diversi- guida isri o grammer (specificare)	Grigio 01
4440005290	2703	1+1	Integrato	Si-guida	Sedili diversi- guida isri o grammer (specificare)	Blu 03
4440005300	2704	1+1	Integrato	Si-guida	Sedili diversi- guida isri o grammer (specificare)	Nero 04

## MERCEDES ACTROS MP1 ISRI



Code	Desc.	Seats	Headrest	Belt <i>integrated</i>	Characteristics	Color
4440005370	3001	1+1	Staccato	Si-guida	2 sedili diversi-cintura su guida	Grigio 01
4440005380	3003	1+1	Staccato	Si-guida	2 sedili diversi-cintura su guida	Blu 03
4440005390	3004	1+1	Staccato	Si-guida	2 sedili diversi-cintura su guida	Nero 04

## MERCEDES ACTROS MP2 GRAMMER



Code	Desc.	Seats	Headrest	Belt <i>integrated</i>	Characteristics	Color
4440005400	3101	1+1	Integrato	Si	Sedile guida grammer passeggero isri	Grigio 01
4440005410	3103	1+1	Integrato	Si	Sedile guida grammer passeggero isri	Blu 03
4440005420	3104	1+1	Integrato	Si	Sedile guida grammer passeggero isri	Nero 04

## MERCEDES ACTROS MP2 ISRI



Code	Desc.	Seats	Headrest	Belt <i>integrated</i>	Characteristics	Color
4440005440	3201	1+1	Integrato	Si	2 sedili isri	Grigio 01
4440005450	3203	1+1	Integrato	Si	2 sedili isri	Blu 03
4440005460	3204	1+1	Integrato	Si	2 sedili isri	Nero 04

## MERCEDES ACTROS MP3 GRAMMER



Code	Desc.	Seats	Headrest	Belt <i>integrated</i>	Characteristics	Color
4440005470	3301	1+1	Integrato	Si	Sedile guida grammer-passeggero isri	Grigio 01
4440005480	3303	1+1	Integrato	Si	Sedile guida grammer-passeggero isri	Blu 03
4440005490	3304	1+1	Integrato	Si	Sedile guida grammer-passeggero isri	Nero 04

## MERCEDES ACTROS MP3 ISRI



Code	Desc.	Seats	Headrest	Belt <i>integrated</i>	Characteristics	Color
4440005510	3401	1+1	Integrato	Si	2 sedili isri	Grigio 01
4440005520	3403	1+1	Integrato	Si	2 sedili isri	Blu 03
4440005530	3404	1+1	Integrato	Si	2 sedili isri	Nero 04

## MERCEDES ACTROS MP4 /ANTOS-AROCS



Code	Desc.	Seats	Headrest	Belt <i>integrated</i>	Characteristics	Color
4440005540	3501	1+1	Integrato	Si	Sedile guida grammer passeggero isri	Grigio 01
4440005550	3503	1+1	Integrato	Si	Sedile guida grammer passeggero isri	Blu 03
4440005560	3504	1+1	Integrato	Si	Sedile guida grammer passeggero isri	Nero 04

## MERCEDES UNIMOG U 400



Code	Desc.	Seats	Headrest	Belt <i>integrated</i>	Characteristics	Color
4440005600	3701	1+1	Si	Si	2 sedili isri con sedile guida poggiatesta integrato	Grigio 01
4440005610	3703	1+1	Si	Si	2 sedili isri con sedile guida poggiatesta integrato	Blu 03
4440005620	3704	1+1	Si	Si	2 sedili isri con sedile guida poggiatesta integrato	Nero 04

## MERCEDES ATEGO ISRI



Code	Desc.	Seats	Headrest	Belt <i>integrated</i>	Characteristics	Color
4440006510	6601	1+1	Si-gomma	Si-guida	2 sedili isri guida con cintura	Grigio 01
4440006520	6603	1+1	Si-gomma	Si-guida	2 sedili isri guida con cintura	Blu 03
4440006530	6604	1+1	Si-gomma	Si-guida	2 sedili isri guida con cintura	Nero 04



## MERCEDES ATEGO



Code	Desc.	Seats	Headrest	Belt <i>integrated</i>	Characteristics	Color
4440006540	6701	1+1	Integrato staccato	Si-guida	sedile guida con poggiatesta integrato (isri o grammer)	Grigio 01
4440006550	6703	1+1	Integrato staccato	Si-guida	sedile guida con poggiatesta integrato (isri o grammer)	Blu 03
4440006560	6704	1+1	Integrato staccato	Si-guida	sedile guida con poggiatesta integrato (isri o grammer)	Nero 04

## MERCEDES ATEGO EURO 6 DAL 2014



Code	Desc.	Seats	Headrest	Belt <i>integrated</i>	Characteristics	Color
4440006570	6801	1+1	Integrato	Si-guida	2 sedili isri con poggiat.integrato -cintura solo su guida	Grigio 01
4440006580	6803	1+1	Integrato	Si-guida	2 sedili isri con poggiat.integrato -cintura solo su guida	Blu 03
4440006590	6804	1+1	Integrato	Si-guida	2 sedili isri con poggiat.integrato -cintura solo su guida	Nero 04

## RENAULT PREMIUM DISTRIBUZIONE



Code	Desc.	Seats	Headrest	Belt <i>integrated</i>	Characteristics	Color
4440005780	4301	1+1	Integrato	Si	2 sedili uguali	Grigio 01
4440005790	4303	1+1	Integrato	Si	2 sedili uguali	Blu 03
4440005800	4304	1+1	Integrato	Si	2 sedili uguali	Nero 04

## RENAULT PREMIUM STRADA



Code	Desc.	Seats	Headrest	Belt <i>integrated</i>	Characteristics	Color
4440005810	4401	1+1	Integrato	Si	2 sedili uguali	Grigio 01
4440005820	4403	1+1	Integrato	Si	2 sedili uguali	Blu 03
4440005830	4404	1+1	Integrato	Si	2 sedili uguali	Nero 04

## RENAULT MAGNUM 440



Code	Desc.	Seats	Headrest	Belt <i>integrated</i>	Characteristics	Color
4440005870	4601	1+1	Integrato	Si	Sedili uguali- cintura dalla stessa parte-dx	Grigio 01
4440005880	4603	1+1	Integrato	Si	Sedili uguali- cintura dalla stessa parte-dx	Blu 03
4440005890	4604	1+1	Integrato	Si	Sedili uguali- cintura dalla stessa parte-dx	Nero 04

## RENAULT SERIE T



Code	Desc.	Seats	Headrest	Belt <i>integrated</i>	Characteristics	Color
4440006390	6201	1+1	Integrato	Si	Gamma K e C uguale	Grigio 01
4440006400	6203	1+1	Integrato	Si	Gamma K e C uguale	Blu 03
4440006410	6204	1+1	Integrato	Si	Gamma K e C uguale	Nero 04

## RENAULT MIDLUM



Code	Desc.	Seats	Headrest	Belt <i>integrated</i>	Characteristics	Color
4440006000	4901	1+2	Integrato	Si/No	Guida con poggiatesta integrato-panca 2 posti con schienali divisi	Grigio 01
4440006010	4903	1+2	Integrato	Si/No	Guida con poggiatesta integrato-panca 2 posti con schienali divisi	Blu 03
4440006020	4904	1+2	Integrato	Si/No	Guida con poggiatesta integrato-panca 2 posti con schienali divisi	Nero 04

## SCANIA SERIE 4 BASIC



Code	Desc.	Seats	Headrest	Belt <i>integrated</i>	Characteristics	Color
4440006060	5101	1+1	Staccato	Si	Serie 94/114/124/164 - 2 sedili uguali	Grigio 01
4440006070	5103	1+1	Staccato	Si	Serie 94/114/124/164 - 2 sedili uguali	Blu 03
4440006080	5104	1+1	Staccato	Si	Serie 94/114/124/164 - 2 sedili uguali	Nero 04

## SCANIA SERIE 4 LUXURI



Code	Desc.	Seats	Headrest	Belt <i>integrated</i>	Characteristics	Color
4440006090	5201	1+1	Integrato	Si	Serie 94/114/124/164 - 2 sedili uguali	Grigio 01
4440006100	5203	1+1	Integrato	Si	Serie 94/114/124/164 - 2 sedili uguali	Blu 03
4440006110	5204	1+1	Integrato	Si	Serie 94/114/124/164 - 2 sedili uguali	Nero 04

## SCANIA R



Code	Desc.	Seats	Headrest	Belt <i>integrated</i>	Characteristics	Color
4440006180	5501	1+1	Integrato	Si	2 sedili uguali	Grigio 01
4440006190	5503	1+1	Integrato	Si	2 sedili uguali	Blu 03
4440006200	5504	1+1	Integrato	Si	2 sedili uguali	Nero 04

## SCANIA R/P



Code	Desc.	Seats	Headrest	Belt <i>integrated</i>	Characteristics	Color
4440006210	5601	1+1	Integrato staccato	Si	lato guida con poggiat.integrato-lato passeggero staccato	Grigio 01
4440006220	5603	1+1	Integrato staccato	Si	lato guida con poggiat.integrato-lato passeggero staccato	Blu 03
4440006230	5604	1+1	Integrato staccato	Si	lato guida con poggiat.integrato-lato passeggero staccato	Nero 04

## VOLVO FH12-16



Code	Desc.	Seats	Headrest	Belt <i>integrated</i>	Characteristics	Color
4440006270	5801	1+1	Staccato	No	2 sedili uguali	Grigio 01
4440006280	5803	1+1	Staccato	No	2 sedili uguali	Blu 03
4440006290	5804	1+1	Staccato	No	2 sedili uguali	Nero 04

## VOLVO FH-FM12 DAL 2000



Code	Desc.	Seats	Headrest	Belt <i>integrated</i>	Characteristics	Color
4440006300	5901	1+1	Integrato	No	2 sedili uguali-può avere cintura integrata	Grigio 01
4440006310	5903	1+1	Integrato	No	2 sedili uguali-può avere cintura integrata	Blu 03
4440006320	5904	1+1	Integrato	No	2 sedili uguali-può avere cintura integrata	Nero 04

## VOLVO FH-FM12 DAL 2008



Code	Desc.	Seats	Headrest	Belt <i>integrated</i>	Characteristics	Color
4440006330	6001	1+1	Integrato	Si	2 sedili diversi con 4 braccioli	Grigio 01
4440006340	6003	1+1	Integrato	Si	2 sedili diversi con 4 braccioli	Blu 03
4440006350	6004	1+1	Integrato	Si	2 sedili diversi con 4 braccioli	Nero 04

## VOLVO NUOVO FL DAL 2007



Code	Desc.	Seats	Headrest	Belt <i>integrated</i>	Characteristics	Color
4440006360	6101	1+1	Integrato	Si	2 Sedili uguali	Grigio 01
4440006370	6103	1+1	Integrato	Si	2 Sedili uguali	Blu 03
4440006380	6104	1+1	Integrato	Si	2 Sedili uguali	Nero 04

## VOLVO FH4 DAL 2013



Code	Desc.	Seats	Headrest	Belt <i>integrated</i>	Characteristics	Color
4440006420	6301	1+1	Integrato	Si	2 sedili diversi con 4 braccioli	Grigio 01
4440006430	6303	1+1	Integrato	Si	2 sedili diversi con 4 braccioli	Blu 03
4440006440	6304	1+1	Integrato	Si	2 sedili diversi con 4 braccioli	Nero 04



## VOLVO FH4 DAL 2013



Code	Desc.	Seats	Headrest	Belt <i>integrated</i>	Characteristics	Color
4440006450	6401	1+1	Integrato	Si-guida	lato guida con cintura /passeggero senza-con 4 braccioli	Grigio 01
4440006460	6403	1+1	Integrato	Si-guida	lato guida con cintura /passeggero senza-con 4 braccioli	Blu 03
4440006470	6404	1+1	Integrato	Si-guida	lato guida con cintura /passeggero senza-con 4 braccioli	Nero 04

## Catalogo Truck tappeti e copricofano



- La gamma dei tappeti si compone di:
- Tappeti in sky nei colori:blu-grigio-nero-beige-rosso
- Tappeti in gomma colore nero
- Tappeti in moquettes nei colori:grigio-antracite-nero
- Copricofano in Sky nei colori: blu-grigio-nero-beige-rosso

### Ski

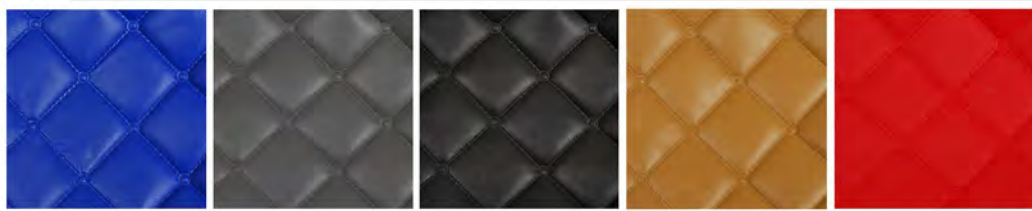

### Gomma millerighe



### Moquette



## DAF XF95 Dal 2002 al 2006 - Copricofano in sky

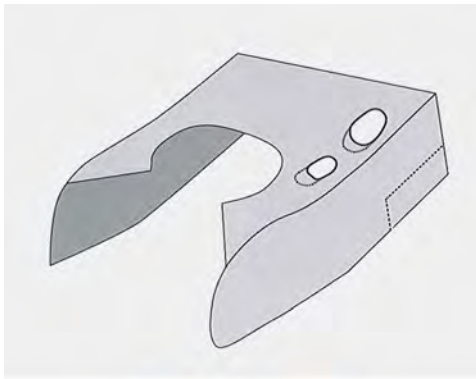

Code	Descrizione/Colore	Model
4440007024	24-blu	cambio manuale
4440007025	25-grigio	cambio manuale
4440007026	26-nero	cambio manuale
4440007027	27-beige	cambio manuale
4440007028	28-rosso	cambio manuale
4440007029	29-blu	cambio automatico
4440007030	30-grigio	cambio automatico
4440007031	31-nero	cambio automatico
4440007032	32-beige	cambio automatico
4440007033	33-rosso	cambio automatico

## DAF XF95 Dal 2002 al 2006 - Tappeto

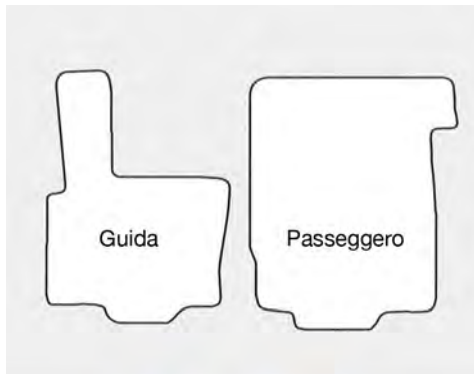

Code	Descrizione/Colore	Material
4440007034	34-blu	sky
4440007035	35-grigio	sky
4440007903	903-nero	sky
4440007036	36-beige	sky
4440007037	37-rosso	sky
4440007038	38-nero	gomma millerighe
4440007039	39-grigio	moquette
4440007040	40-antracite	moquette
4440007041	41-nero	moquette

## DAF XF105 Dal 2006 al 2013 - Copricofano in sky

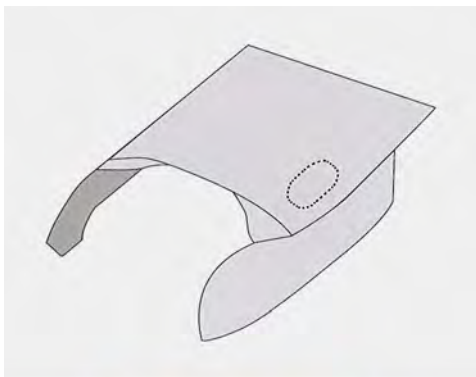

Code	Descrizione/Colore	Model
4440007042	42-blu	cambio manuale
4440007043	43-grigio	cambio manuale
4440007044	44-nero	cambio manuale
4440007045	45-beige	cambio manuale
4440007046	46-rosso	cambio manuale
4440007047	47-blu	cambio automatico
4440007048	48-grigio	cambio automatico
4440007049	49-nero	cambio automatico
4440007050	50-beige	cambio automatico
4440007051	51-rosso	cambio automatico

## DAF XF105 Dal 2006 al 2013 - Tappeto

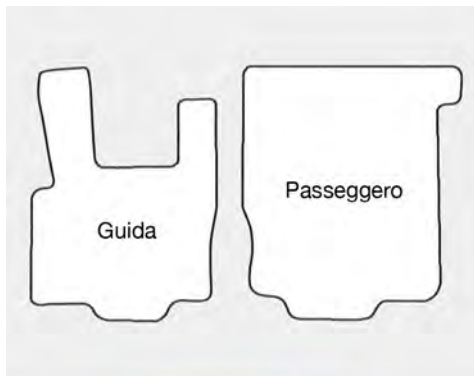

Code	Descrizione/Colore	Material
4440007052	52-blu	sky
4440007053	53-grigio	sky
4440007054	54-nero	sky
4440007055	55-beige	sky
4440007056	56-rosso	sky
4440007057	57-nero	gomma millerighe
4440007058	58-grigio	moquette
4440007059	59-antracite	moquette
4440007060	60-nero	moquette

## DAF XF 106 DAL 2013 - Copricofano in sky

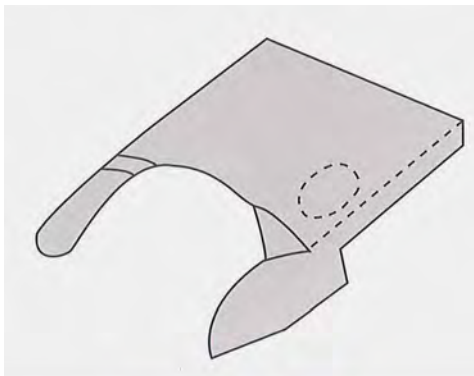

Code	Descrizione/Colore	Model
4440007061	61-blu	cambio manuale
4440007062	62-grigio	cambio manuale
4440007063	63-nero	cambio manuale
4440007064	64-beige	cambio manuale
4440007065	65-rosso	cambio manuale
4440007066	66-blu	cambio automatico
4440007067	67-grigio	cambio automatico
4440007068	68-nero	cambio automatico
4440007069	69-beige	cambio automatico
4440007070	70-rosso	cambio automatico

## DAF XF 106 DAL 2013 - Tappeto

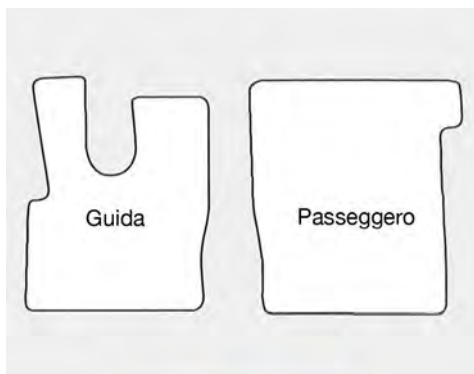

Code	Descrizione/Colore	Material
4440007071	71-blu	sky
4440007072	72-grigio	sky
4440007073	73-nero	sky
4440007074	74-beige	sky
4440007075	75-rosso	sky
4440007076	76-nero	gomma millerighe
4440007077	77-grogio	moquette
4440007078	78-antracite	moquette
4440007079	79-nero	moquette

## DAF CF ( 65-75-85 ) DAL 2001 AL 2013 - Copricofano in sky

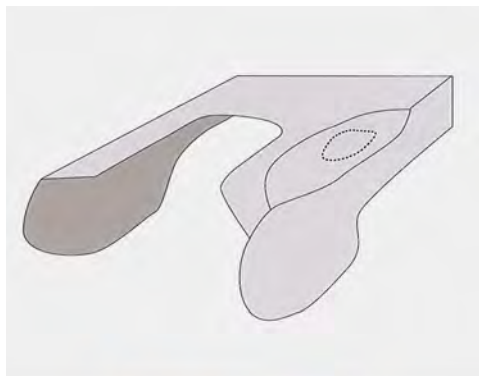

Code	Descrizione/Colore	Model
4440007080	80-blu	cambio manuale
4440007081	81-grigio	cambio manuale
4440007082	82-nero	cambio manuale
4440007083	83-beige	cambio manuale
4440007084	84-rosso	cambio manuale
4440007085	85-blu	cambio automatico
4440007086	86-grigio	cambio automatico
4440007087	87-nero	cambio automatico
4440007088	88-beige	cambio automatico
4440007089	89-rosso	cambio automatico

## DAF CF ( 65-75-85 ) DAL 2001 AL 2013 - Tappeto

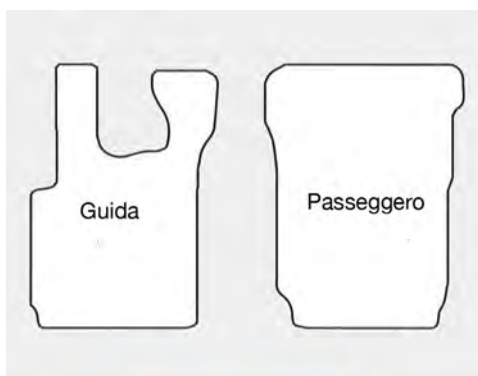

Code	Descrizione/Colore	Material
4440007090	90-blu	sky
4440007091	91-grigio	sky
4440007092	92-nero	sky
4440007093	93-beige	sky
4440007094	94-rosso	sky
4440007095	95-nero	gomma millerighe
4440007096	96-grigio	moquette
4440007097	97-antracite	moquette
4440007098	98-nero	moquette

## IVECO EUROCARGO DAL 2008 - Tappeto

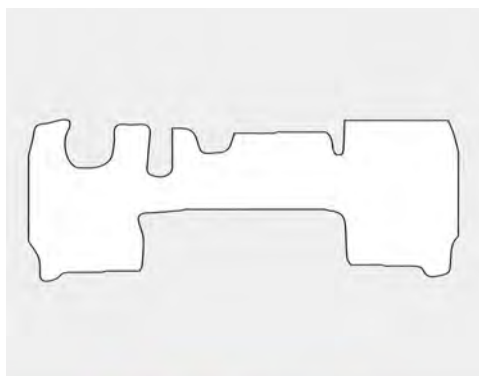

Code	Descrizione/Colore	Material
4440007508	508-blu	sky
4440007509	509-grigio	sky
4440007510	510-nero	sky
4440007511	511-beige	sky
4440007512	512-rosso	sky
4440007513	513-nero	gomma millerighe
4440007514	514-grigio	moquette
4440007515	515-antracite	moquette
4440007516	516-nero	moquette



## IVECO STRALIS AS EURO 5 DAL 2007 - copricofano in sky

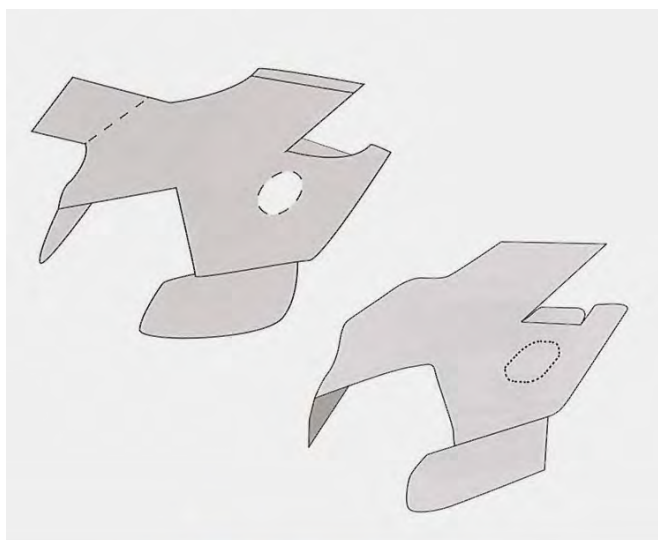

Code	Descrizione/Colore	Model
4440007588	588-blu	cambio manuale 1 sedile
4440007589	589-grigio	cambio manuale 1 sedile
4440007590	590-nero	cambio manuale 1 sedile
4440007591	591-beige	cambio manuale 1 sedile
4440007592	592-rosso	cambio manuale 1 sedile
4440007593	593-blu	cambio manuale 2 sedili
4440007594	594-grigio	cambio manuale 2 sedili
4440007595	595-nero	cambio manuale 2 sedili
4440007596	596-beige	cambio manuale 2 sedili
4440007597	597-rosso	cambio manuale 2 sedili
4440007598	598-blu	cambio automatico 1 sedile
4440007599	599-grigio	cambio automatico 1 sedile
4440007600	600-nero	cambio automatico 1 sedile
4440007601	601-beige	cambio automatico 1 sedile
4440007602	602-rosso	cambio automatico 1 sedile
4440007603	603-blu	cambio automatico 2 sedili
4440007604	604-grigio	cambio automatico 2 sedili
4440007605	605-nero	cambio automatico 2 sedili
4440007606	606-beige	cambio automatico 2 sedili
4440007607	607-rosso	cambio automatico 2 sedili

## IVECO STRALIS AS EURO 5 DAL 2007 - Tappeto

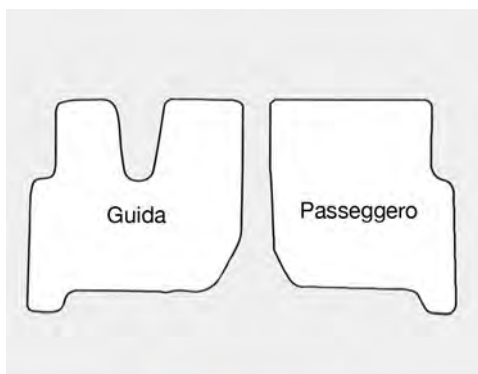

Code	Descrizione/Colore	Material
4440007608	608-blu	sky
4440007609	609-grigio	sky
4440007610	610-nero	sky
4440007611	611-beige	sky
4440007612	612-rosso	sky
4440007613	613-nero	gomma millerighe
4440007614	614-grigio	moquette
4440007615	615-antracite	moquette
4440007616	616-nero	moquette

## IVECO STRALIS HI WAY dal 2013 - copricofano in sky

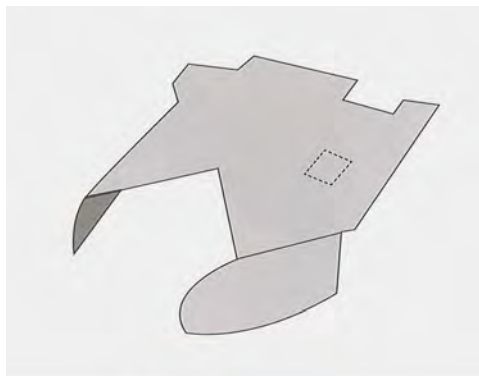

Code	Descrizione/Colore	Model
4440007636	636-blu	cambio manuale
4440007637	637-grigio	cambio manuale
4440007638	638-nero	cambio manuale
4440007639	639-beige	cambio manuale
4440007640	640-rosso	cambio manuale
4440007641	641-blu	cambio automatico
4440007642	642-grigio	cambio automatico
4440007643	643-nero	cambio automatico
4440007644	644-beige	cambio automatico
4440007645	645-rosso	cambio automatico

## IVECO STRALIS HI WAY dal 2013 - Tappeto

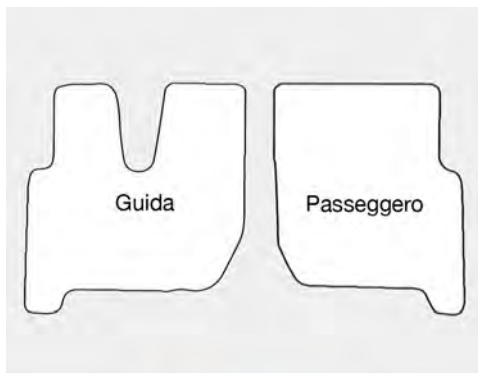

Code	Descrizione/Colore	Material
4440007646	646-blu	sky
4440007647	647-grigio	sky
4440007648	648-nero	sky
4440007649	649-beige	sky
4440007650	650-rosso	sky
4440007651	651-nero	gomma millerighe
4440007652	652-grigio	moquette
4440007653	653-antracite	moquette
4440007654	654-nero	moquette

## MAN TGA ( CAB XL/XLX/XXL ) DAL 2000 - Copricofano in sky

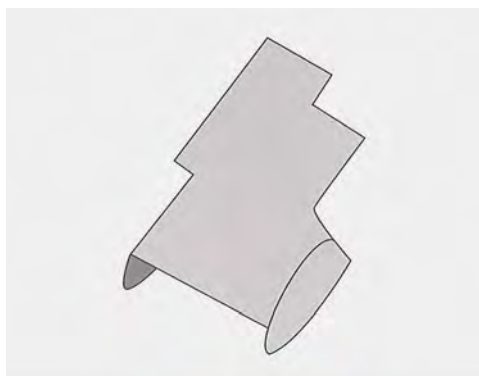

Code	Descrizione/Colore
4440007216	216-blu
4440007217	217-grigio
4440007218	218-nero
4440007219	219-beige
4440007220	220-rosso

## MAN TGA ( CAB XL/XLX/XXL ) DAL 2000 - Tappeto

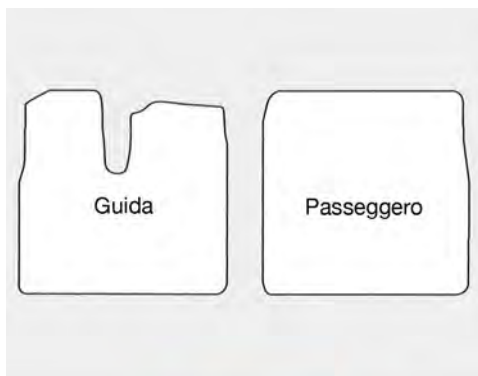

Code	Descrizione/Colore	Material
4440007221	221-blu	sky
4440007222	222-grigio	sky
4440007223	223-nero	sky
4440007224	224-beige	sky
4440007225	225-rosso	sky
4440007226	226-nero	gomma millerighe
4440007227	227-grigio	moquette
4440007228	228-antracite	moquette
4440007229	229-nero	moquette

## MAN TGL ( 1+1 ) DAL 2005 - Tappeto

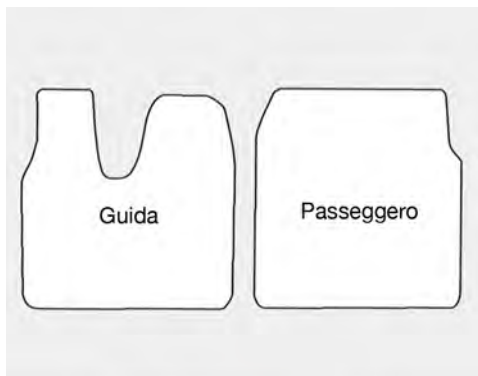

Code	Descrizione/Colore	Material
4440007315	315-blu	sky
4440007316	316-grigio	sky
4440007317	317-nero	sky
4440007318	318-beige	sky
4440007319	319-rosso	sky
4440007320	320-nero	gomma millerighe
4440007321	321-grigio	moquette
4440007322	322-antracite	moquette
4440007323	323-nero	moquette

## MAN TGL ( 1+2 ) DAL 2005 - Tappeto

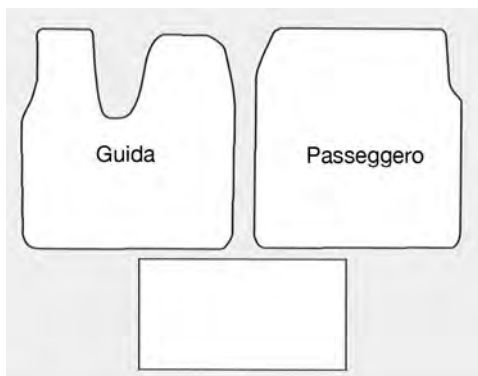

Code	Descrizione/Colore	Material
4440007301	301-blu	sky
4440007302	302-grigio	sky
4440007303	303-nero	sky
4440007304	304-beige	sky
4440007305	305-rosso	sky
4440007306	306-nero	gomma millerighe
4440007307	307-grigio	moquette
4440007308	308-antracite	moquette
4440007309	309-nero	moquette

## MAN TGM ( 1+1 ) DAL 2007 - Tappeto

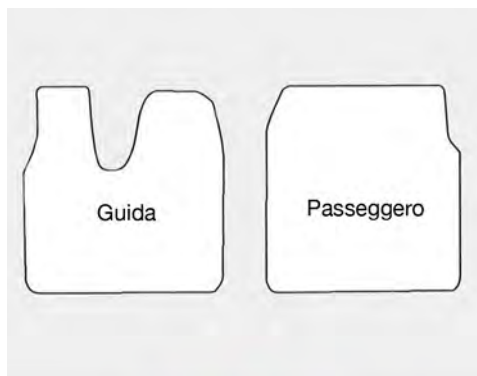

Code	Descrizione/Colore	Material
4440007287	287-blu	sky
4440007288	288-grigio	sky
4440007289	289-nero	sky
4440007290	290-beige	sky
4440007291	291-rosso	sky
4440007292	292-nero	gomma millerighe
4440007293	293-grigio	moquette
4440007294	294-antracite	moquette
4440007295	295-nero	moquette

## MAN TGM ( 1+2 ) DAL 2007 - Tappeto

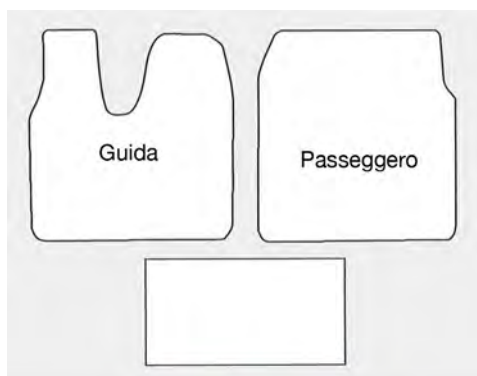

Code	Descrizione/Colore	Material
4440007273	273-blu	sky
4440007274	274-grigio	sky
4440007275	275-nero	sky
4440007276	276-beige	sky
4440007277	277-rosso	sky
4440007278	278-nero	gomma millerighe
4440007279	279-grigio	moquette
4440007280	280-antracite	moquette
4440007281	281-nero	moquette

## MAN TGS DAL 2007 - Copricofano in sky

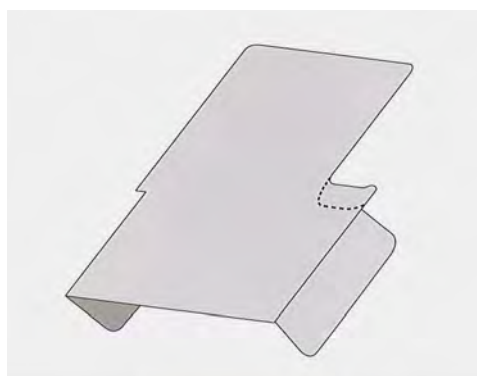

Code	Descrizione/Colore	Model
4440007249	249-blu	cambio manuale
4440007250	250-grigio	cambio manuale
4440007251	251-nero	cambio manuale
4440007252	252-beige	cambio manuale
4440007253	253-rosso	cambio manuale
4440007254	254-blu	cambio automatico
4440007255	255-grigio	cambio automatico
4440007256	256-nero	cambio automatico
4440007257	257-beige	cambio automatico
4440007258	258-rosso	cambio automatico



## MAN TGS DAL 2007 - Tappeto

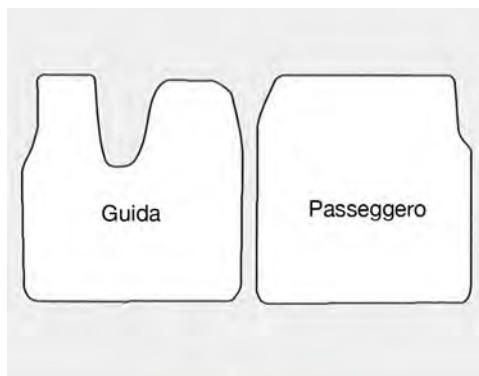

Code	Descrizione/Colore	Material
4440007259	259-blu	sky
4440007260	260-grigio	sky
4440007261	261-nero	sky
4440007262	262-beige	sky
4440007263	263-rosso	sky
4440007264	264-nero	gomma millerighe
4440007265	265-grigio	moquette
4440007266	266-antracite	moquette
4440007267	267-nero	moquette

## MAN TGX DAL 2007 - Copricofano in sky

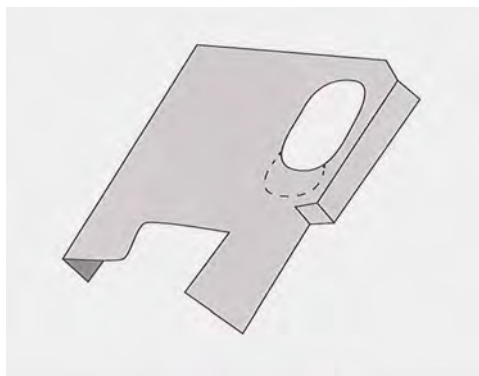

Code	Descrizione/Colore	Model
4440007230	230-blu	cambio manuale
4440007231	231-grigio	cambio manuale
4440007232	232-nero	cambio manuale
4440007233	233-beige	cambio manuale
4440007234	234-rosso	cambio manuale
4440007235	235-blu	cambio automatico
4440007236	236-grigio	cambio automatico
4440007237	237-nero	cambio automatico
4440007238	238-beige	cambio automatico
4440007239	239-rosso	cambio automatico

## MAN TGX DAL 2007 - Tappeto

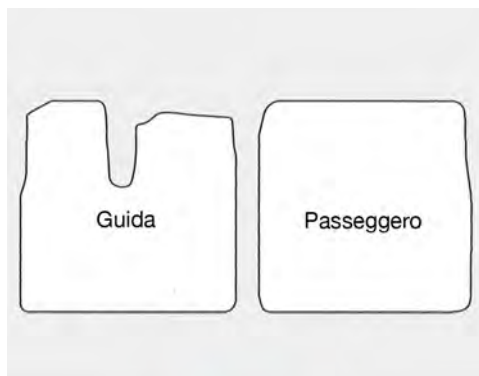

Code	Descrizione/Colore	Material
4440007240	240-blu	sky
4440007241	241-grigio	sky
4440007242	242-nero	sky
4440007243	243-beige	sky
4440007244	244-rosso	sky
4440007245	245-nero	gomma millerighe
4440007246	246-grigio	moquette
4440007247	247-antracite	moquette
4440007248	248-nero	moquette

## MERCEDES ACTROS ( MP2+MP3 ) DAL 2003 AL 2008 - copricofano in sky

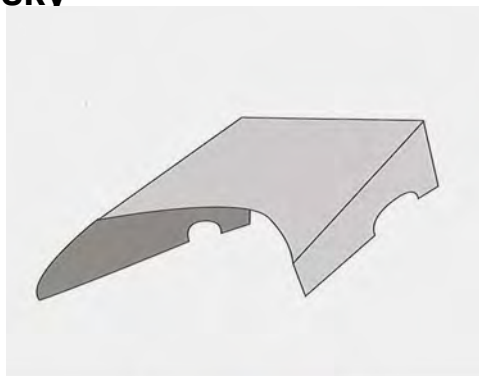

Code	Descrizione/Colore
4440007453	453-blu
4440007454	454-grigio
4440007455	455-nero
4440007456	456-beige
4440007457	457-rosso



## MERCEDES ACTROS ( MP2+MP3 ) DAL 2003 AL 2008 - Tappeto

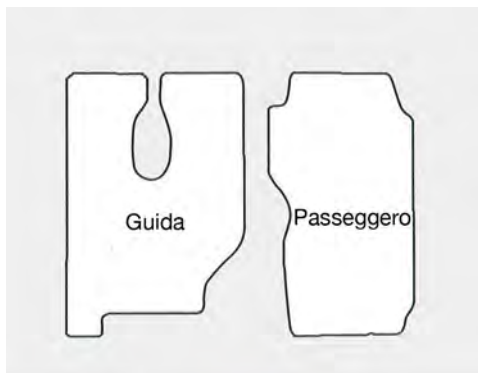

Code	Descrizione/Colore	Material
4440007458	458-blu	sky
4440007459	459-grigio	sky
4440007460	460-nero	sky
4440007461	461-beige	sky
4440007462	462-rosso	sky
4440007463	463-nero	gomma millerighe
4440007464	464-grigio	moquette
4440007465	465-antracite	moquette
4440007466	466-nero	moquette

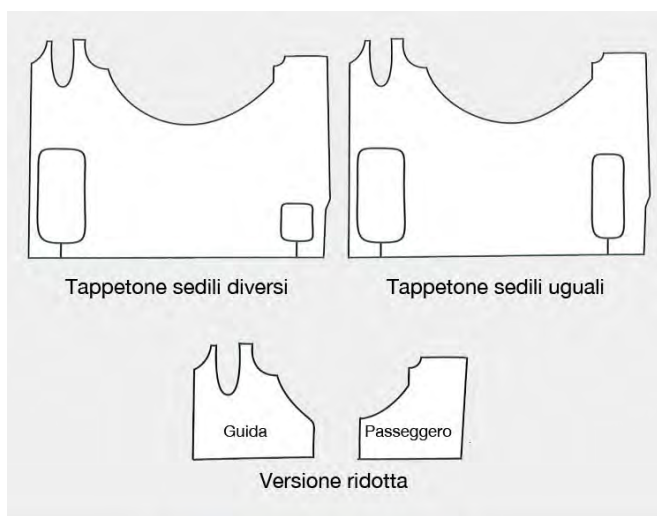

**MERCEDES ACTROS (MP4+MP4 RIDOTTO) DAL 2012 - Tappeto**

Code	Descrizione/Colore	Material
4440007467	467-blu	sky sedili diversi
4440007468	468-grigio	sky sedili diversi
4440007469	469-nero	sky sedili diversi
4440007470	470-beige	sky sedili diversi
4440007471	471-rosso	sky sedili diversi
4440007941	941-blu	sky sedili uguali
4440007942	942-grigio	sky sedili uguali
4440007943	943-nero	sky sedili uguali
4440007954	954-beige	sky sedili uguali
4440007955	955-rosso	sky sedili uguali
4440007472	472-blu	sky (versione ridotta)
4440007473	473-grigio	sky (versione ridotta)
4440007474	474-nero	sky (versione ridotta)
4440007475	475-beige	sky (versione ridotta)
4440007476	476-rosso	sky (versione ridotta)
4440007477	477-nero	gomma millerighe (versione ridotta)
4440007478	478-grigio	moquette sedili diversi
4440007479	479-antracite	moquette sedili diversi
4440007480	480-nero	moquette sedili diversi
4440007944	944-grigio	moquette sedili uguali
4440007945	945-antracite	moquette sedili uguali
4440007946	946-nero	moquette sedili uguali
4440007922	922-grigio	moquette versione ridotta
4440007923	923-antracite	moquette versione ridotta
4440007924	924-nero	moquette versione ridotta

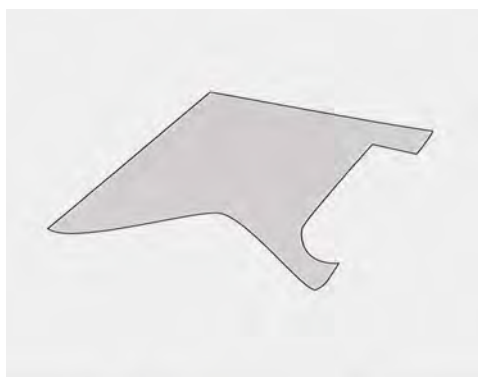
**RENAULT PREMIUM DAL 2006 - copricofano in sky**

Code	Descrizione/Colore
4440007678	678-blu
4440007679	679-grigio
4440007680	680-nero
4440007681	681-beige
4440007682	682-rosso



## RENAULT PREMIUM DAL 2006 - Tappeto

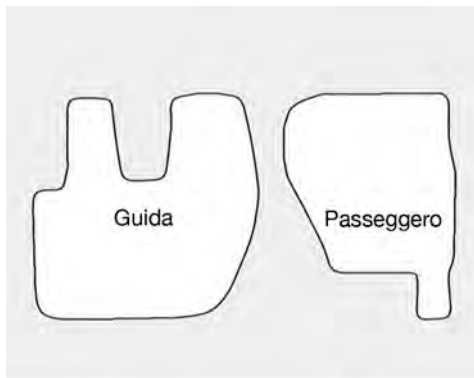

Code	Descrizione/Colore	Material
4440007664	664-blu	sky
4440007665	665-grigio	sky
4440007666	666-nero	sky
4440007667	667-beige	sky
4440007668	668-rosso	sky
4440007669	669-nero	gomma millerighe
4440007670	670-grigio	moquette
4440007671	671-antracite	moquette
4440007672	672-nero	moquette

## SCANIA SERIE G DAL 2004 - Copricofano in sky

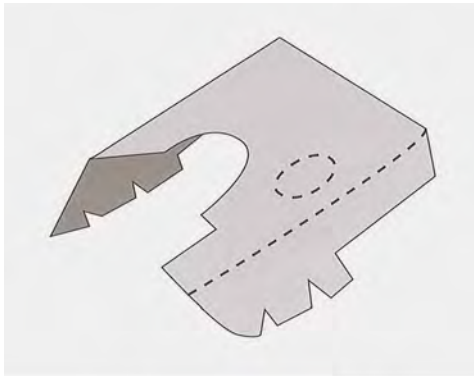

Code	Descrizione/Colore	Model
4440007183	183-blu	cambio manuale
4440007184	184-grigio	cambio manuale
4440007185	185-nero	cambio manuale
4440007186	186-beige	cambio manuale
4440007187	187-rosso	cambio manuale
4440007188	188-blu	cambio automatico
4440007189	189-grigio	cambio automatico
4440007190	190-nero	cambio automatico
4440007191	191-beige	cambio automatico
4440007192	192-rosso	cambio automatico

## SCANIA SERIE G DAL 2004 - Tappeto



Code	Descrizione/Colore	Material
4440007193	193-blu	sky
4440007194	194-grigio	sky
4440007195	195-nero	sky
4440007196	196-beige	sky
4440007197	197-rosso	sky
4440007198	198-nero	gomma millerighe
4440007199	199-grigio	moquette
4440007200	200-antracite	moquette
4440007201	201-nero	moquette



## SCANIA SERIE P dal 2004 - Copricofano in sky

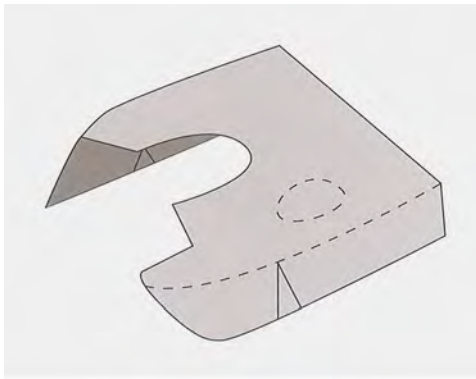

Code	Descrizione/Colore	Model
4440007164	164-blu	cambio manuale
4440007165	165-grigio	cambio manuale
4440007166	166-nero	cambio manuale
4440007167	167-beige	cambio manuale
4440007168	168-rosso	cambio manuale
4440007169	169-blu	cambio automatico
4440007170	170-grigio	cambio automatico
4440007171	171-nero	cambio automatico
4440007172	172-beige	cambio automatico
4440007173	173-rosso	cambio automatico

## SCANIA SERIE P dal 2004 - Tappeto

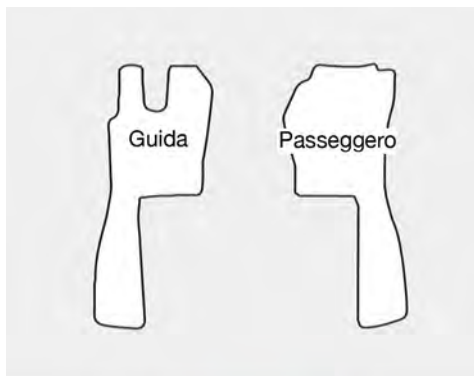

Code	Descrizione/Colore	Material
4440007174	174-blu	sky
4440007175	175-grigio	sky
4440007176	176-nero	sky
4440007177	177-beige	sky
4440007178	178-rosso	sky
4440007179	179-nero	gomma millerighe
4440007180	180-grigio	moquette
4440007181	181-antracite	moquette
4440007182	182-nero	moquette

## SCANIA SERIE R DAL 2005 AL 2010 - Copricofano in sky

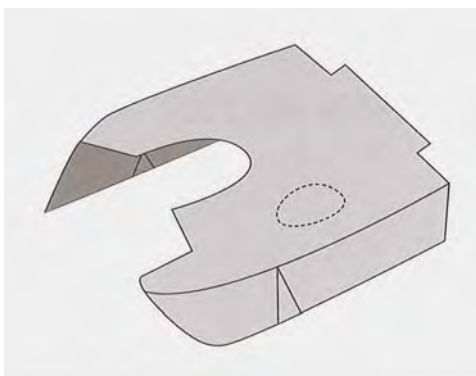

Code	Descrizione/Colore	Model
4440007127	127-blu	cambio manuale
4440007128	128-grigio	cambio manuale
4440007129	129-nero	cambio manuale
4440007130	130-beige	cambio manuale
4440007131	131-rosso	cambio manuale
4440007132	132-blu	cambio automatico
4440007133	133-grigio	cambio automatico
4440007134	134-nero	cambio automatico
4440007135	135-beige	cambio automatico
4440007136	136-rosso	cambio automatico

## SCANIA SERIE R DAL 2005 AL 2010 - Tappeto



Code	Descrizione/Colore	Material
4440007137	137-blu	sky
4440007138	138-grigio	sky
4440007139	139-nero	sky
4440007140	140-beige	sky
4440007141	141-rosso	sky
4440007142	142-nero	gomma millerighe
4440007143	143-grigio	moquette
4440007144	144-antracite	moquette
4440007145	145-nero	moquette

## SCANIA SERIE R DAL 2010 - Copricofano in sky

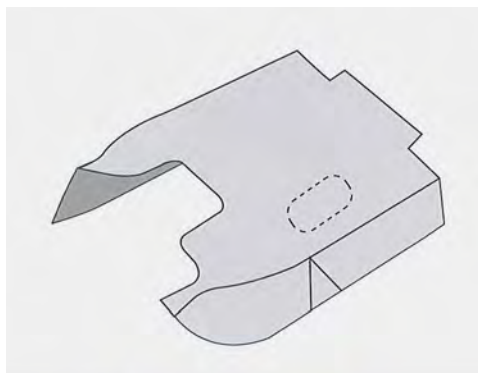

Code	Descrizione/Colore	Model
4440007146	146-blu	cambio manuale
4440007147	147-grigio	cambio manuale
4440007148	148-nero	cambio manuale
4440007149	149-beige	cambio manuale
4440007150	150-rosso	cambio manuale
4440007151	151-blu	cambio automatico
4440007152	152-grigio	cambio automatico
4440007902	902-nero	cambio automatico
4440007153	153-beige	cambio automatico
4440007154	154-rosso	cambio automatico

## SCANIA SERIE R DAL 2010 - Tappeto

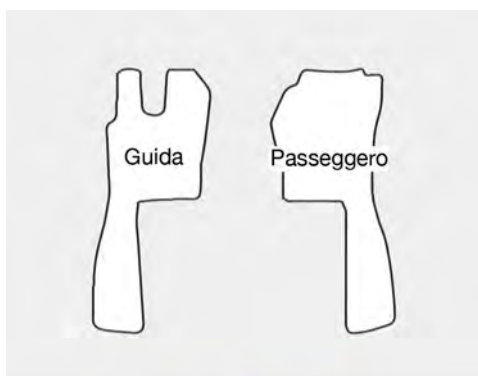

Code	Descrizione/Colore	Material
4440007155	155-blu	sky
4440007156	156-grigio	sky
4440007157	157-nero	sky
4440007158	158-beige	sky
4440007159	159-rosso	sky
4440007160	160-nero	gomma millerighe
4440007161	161-grigio	moquette
4440007162	162-antracite	moquette
4440007163	163-nero	moquette

## VOLVO FH DAL 2012 - copricofano in sky

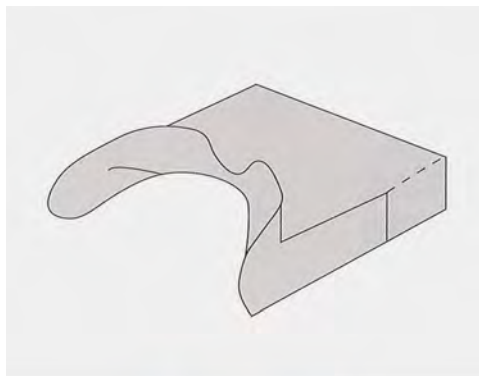

Code	Descrizione/Colore	Model
4440007384	384-blu	Cambio automatico
4440007385	385-grigio	Cambio automatico
4440007386	386-nero	Cambio automatico
4440007387	387-beige	Cambio automatico
4440007388	388-rosso	Cambio automatico



## VOLVO FH DAL 2012 - Tappeto

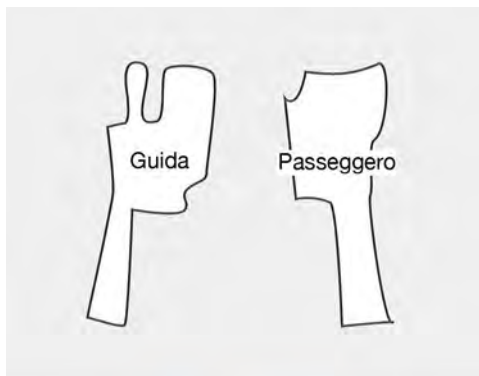

Code	Descrizione/Colore	Material
4440007389	389-blu	sky
4440007390	390-grigio	sky
4440007391	391-nero	sky
4440007392	392-beige	sky
4440007393	393-rosso	sky
4440007394	394-nero	gomma millerighe
4440007395	395-grigio	moquette
4440007396	396-antracite	moquette
4440007397	397-nero	moquette



## VOLVO FL6 DAL 2006 - Tappeto

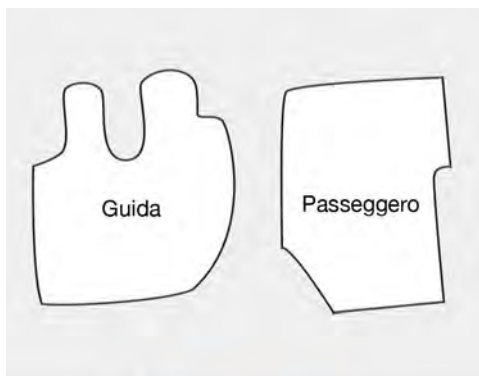

Code	Descrizione/Colore	Material
4440007342	342-blu	sky
4440007343	343-grigio	sky
4440007344	344-nero	sky
4440007345	345-beige	sky
4440007346	346-rosso	sky
4440007347	347-nero	gomma millerighe
4440007348	348-grigio	moquette
4440007349	349-antracite	moquette
4440007350	350-nero	moquette



## Spirals jointed for pneumatic brakes cargo



- Connection between tractor and trailer or semitrailer outlet fitting male / male 16x1.5 moveable.
- To create female outlet depending on the on requirements.
- Coiled tubing diameter 9x12.
- Black spiral full bulkhead fitting for IVECO 190-48.

Code	Desc.	Type
3450008550	260 N	BLACK SPIRAL CONNECTION WITH LONG 18x1.5
3450008450	260 G	YELLOW SPIRAL
3450008500	260 R	RED SPIRAL



## Cable sections polyurethane jointed



- New spirals in polyurethane.
- Jointed at the ends with 16x1.5 fitting.
- Conforming to DIN 74323 to 74324.
- Universal for all vehicles.
- Reduced diameter spiral.
- Polyurethane material with high resistance.
- Available colors yellow and red.
- Extension mt. 5.

Code	Desc.	Color	Measure	Connection extremity Male	Spiral diam.	N° coils	Explosion press.	Press. operating
3450010312	SPU 12	RED	12X8	16x1,5+18x1,5	70 mm	25	45 bar	20 bar
3450010313	SPU 13	YELLOW	12X8	16x1,5+18x1,5	70 mm	25	45 bar	20 bar
3450010300	SPU 11	RED	12X8	16x1,5+16x1,5	70 mm	24	45 bar	20 bar
3450010310	SPU 10	YELLOW	12X8	16x1,5+16x1,5	70 mm	24	45 bar	20 bar



## Spirals red and yellow polyurethane jointed "2 in 1"

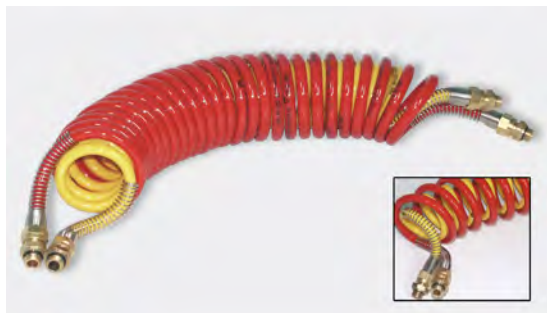

- New spirals in polyurethane.
- Jointed at the ends' with 16x1.5 fitting.
- Conforming to DIN 74323 to 74324.
- Universal for all vehicles.
- Polyurethane material with high resistance.
- Available colors yellow and red.
- Extension mt. 4.5.
- Small footprint at maximum performance.

Code	Desc.	Color	Tubo	Spiral diam.	N° coils	Explosion press.	Press. operating
3450010320	SPU 20	RED / YELLOW	12x8	90/70 mm	24	45 bar	20 bar

## Spirali sottotimone



- Tubo sottotimone in pa 12 parzialmente spiralato
- Indicate per il collegamento dell'impianto frenante tra rimorchio e motrice

Code	Desc.	Color	Tubo	Connector M (1)	Connector M (2)	Leng. mm
3450008572	270ST-R	Rosso	12x9	16x1,5	22x1,5	2970
3450008573	270ST-G	Giallo	12x9	16x1,5	22x1,5	2970
3450008574	280ST-R	Rosso	12x9	16x1,5	no	2970
3450008575	280ST-G	Giallo	12x9	16x1,5	no	2970
3450008576	290ST-R	Rosso	12x9	no	no	2970
3450008577	290ST-G	Giallo	12x9	no	no	2970

## Couplings motive



- The valve opens when there 'pressure and closes when you drop the joints.

Code	Desc.	Type
3450008650	261 V-R	RED WITH VALVE
3450008600	261 V-G	YELLOW WITH VALVE

## Kit spare joints



- kit spare joints.

Code	Description
3450008757	262/2 - kit spare joints

## Couplings trailer and semitrailer



- Coupling fixed on the trailer or semi-trailer to be coupled to the one with the valve.

Code	Desc.	Type
3450008750	262 R	RED WITHOUT VALVE
3450008700	262 G	YELLOW WITHOUT VALVE

## Rubber spare joints



- Rubber spare joints.

Code	Description
3450008755	262/1 - Rubber spare joints

## Giunti per rimorchio



- Giunti per rimorchio con filtro e con presa di pressione
- Questi giunti sono la versione aggiornata per quanto concerne i giunti per rimorchi

Code	Description	Color	Tthread	Adaptable Wabco
3450008772	265R/Rosso c/filtro	Rosso	F 16x1,5	952.201.002.0
3450008774	265G/Giallo c/filtro	Giallo	F 16x1,5	952.201.001.0
3450008776	266g/Giallo c/filtro e presa pressione	Giallo	F16x1,5	952.201.008.0
3450008778	266G/Giallo c/filtro e presa pressione	Giallo	F16x1,5+M24x1,5	952.201.007.0

## Kits detaches joints braking system



Facilitano le operazioni di accoppiamento e disaccoppiamento dei giunti fornendo alta protezione alle mani.

Garantiscono maggiore sicurezza stradale.

- Handles functional energisation and engagement of the joints of the brake system.
- Kit complete with 2 handles and 2 connections for joints.
- Convenient to install.
- Shape and ergonomic design specially designed to ensure the absolute safety of hands during the coupling and uncoupling.
- Enable effective protection of the pipes of the braking system for greater road safety.
- Certificates ISO, allow the compatibility 'with each type of vehicle.

### HOW TO USE:

- Make sure that the joints are not under pressure.
- Unscrew the hose fittings spiral from couplings furniture.
- Assemble fittings "to" washers and sealing joints.
- Tighten the fittings, coiled and washers seal the fittings "A".
- Tighten the semi-grips with the screws.
- Restore the pressure in the joints to verify the correct coupling and relative operation of the plant.

Code	Description
3450008752	262K- KIT DETACHES JOINTS

## Giunti di accoppiamento motrice



- Versione con valvola
- Giunti per impianto frenante pneumatico cargo tra motrice e rimorchio o motrice e semirimorchio
- A norma iso 1728
- Filetto F.16x1,5

Code	Description
3450008651	261C V rosso con valvola
3450008601	261C V Giallo con valvola

## Giunti di accoppiamento rimorchio e semirimorchio



- Versione senza valvola
- Giunti per impianto frenante pneumatico fissato sul rimorchio o semirimorchio
- A norma iso 1728
- Filetto F.16x1,5

Code	Description
3450008751	262C rosso senza valvola
3450008701	262C giallo senza valvola

## Filtro aria



- Da utilizzarsi in abbinamento ai giunti ISO tradizionali per rimorchio e semirimorchio n/s 3450008700/08750

Code	Description	Tthread	Adaptable <i>Wabco</i>
3450008780	267-filtro aria	F 22x1,5	432.500.000.0
1760034130	822205 raccordo adattatore	M22x1,5-F 16x1,5	-

## Supporto per giunti



- Staffa di aggancio per giunti
- Serve per agganciare i giunti iso quando non vengono utilizzati

Code	Description	Adaptable <i>Wabco</i>
3450008782	268 Staffa x giunti	452.402.000.0

## Kit air passage for trucks



- The kit includes: blowing gun nylon, polyurethane spiral length 4 me "T" to intercept air tubes  $\varnothing$  6 mm.
- Used mainly for internal cabin industrial vehicles.

Code	Desc.
3450008200	250

## Kit air passage for trucks



- The kit includes: blowing gun nylon, polyurethane spiral length 4 me "T" to intercept air tubes  $\varnothing$  6 mm.
- Used mainly for internal cabin industrial vehicles.

Code	Desc.
3450008210	251



## Kit per cabina autocarro



- Con adattatori per l'impiego su :Scania,Man,Stralis e Eurocargo

Code	Description	Adaptable
3450008212	251/S-KIT ARIA	Scania, Man, Stralis, Eurocargo

## Raccordi gasolio forati 1 via

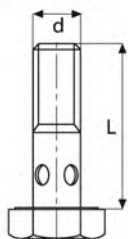

Code	Desc. d x L x pace
1450000100	6x15x1
1450000195	8x16x1
1450000200	8x16x1,25
1450000210	10x23x1
1450000212	10x18x1,25
1450000214	10x20x1,5
1450000240	12x23x1,5
1450000245	12x23x1,25
1450000250	14x28x1,5
1450000280	16x28x1,5
1450000285	18x34x1,5
1450000300	20x35x1,5
1450000350	22x36x1,5
1450000500	24x38x1,5

- Tipo di materiale: acciaio
- Filettatura metrica

## Connections eye no beat

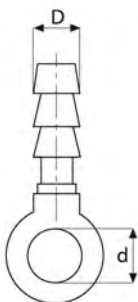

- Type of material: steel.
- For rubber hoses.

Code	Desc. d - D
1500000100	8 - 4
1500000400	10 - 6
1500000600	12 - 8
1500000700	14 - 8
1500000800	14 - 10

## Bicones brass joints

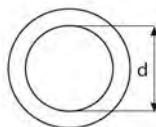
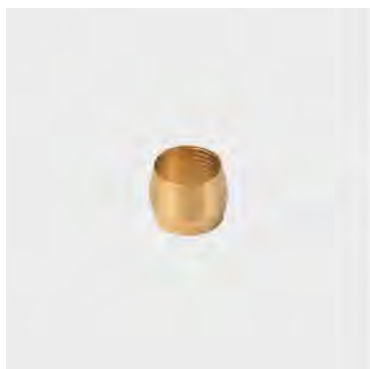

Code	Desc. d
1490000100	4
1490000200	5
1490000300	6
1490000400	8
1490000500	10
1490000600	12
1490000700	14

## Brass joints

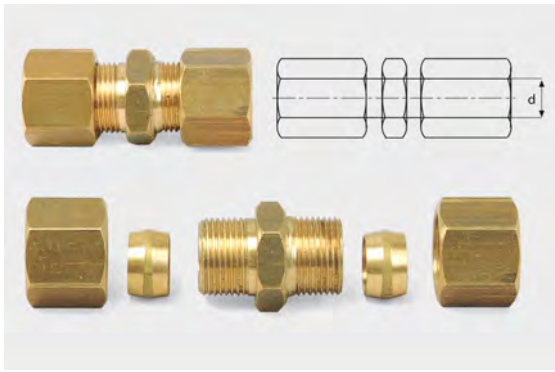

- Complete with bicones and nuts.
- For the joining of metal tubes.
- Article. 148 and 'made of five pieces.

Code	Desc. <i>d</i>
1480000100	4
1480000200	5
1480000300	6
1480000400	8
1480000500	10
1480000600	12
1480000700	14

## Connections diesel IVECO - Union elbow



Code	Desc.	For pipe Ø
5050000400	4147-10-8	10 - 8

## Connections diesel IVECO - Union straight



Code	Desc.	For pipe Ø
5050000500	416-10-10	10 - 10

## Air connection union rights for braking systems

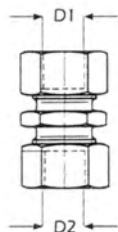

Code	Desc.	Ø tubo D1	Ø tubo D2
1760029000	112002	6	6
1760029010	112052	8	8
1760029020	112062	8	6
1760029030	112102	10	10
1760029040	112112	10	8
1760029050	112152	12	12
1760029060	112162	12	10
1760006740	112702	14	14
1760029080	112202	15	15
1760029090	112212	15	12
1760029100	251932	16	16
1760029105	251936	16	10
1760029110	112252	18	18
1760029120	112262	18	15
1760029122	112802	20	20
1760029124	112812	20	16
1760029126	112832	20	12
1760029128	112842	20	10
1760029130	112302	22	22
1760029132	112312	22	18
1760029134	112322	22	15
1760029136	112332	22	12

- For rigid and Rilsan tubes.
- Complete with sleeves and nuts.

## Air connection union to "L" for braking systems

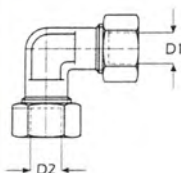
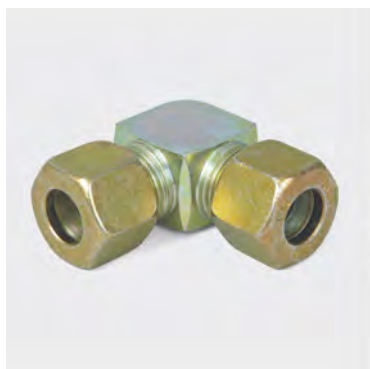

Code	Desc.	Ø tubo D1	Ø tubo D2
1760029200	120002	6	6
1760029210	120052	8	8
1760029220	120102	10	10
1760029230	120152	12	12
1760029240	120702	14	14
1760029250	120202	15	15
1760029260	120752	16	16
1760029270	120252	18	18
1760029271	120802	20	20
1760029272	120302	22	22

- For pipes and Rilsan.
- Complete with bushings and nuts.



## Air connection union "T" for braking systems

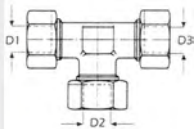

Code	Desc.	Ø tubo D1	Ø tubo D2	Ø tubo D3
1760029300	134003	6	6	6
1760029310	134052	8	8	8
1760029320	134102	10	10	10
1760029330	134152	12	12	12
1760029340	134702	14	14	14
1760029350	134202	15	15	15
1760029360	134752	16	16	16
1760029370	134252	18	18	18
1760029372	134802	20	20	20
1760029374	134812	20	16	20
1760029376	134832	20	12	20
1760029378	134842	20	10	20
1760029380	134302	22	22	22
1760029382	134312	22	18	22
1760029384	134322	22	15	22
1760029386	134332	22	12	22
1760029388	134342	22	10	22

- For pipes and Rilsan.
- Complete with bushings and nuts.

## Raccordo a T con dado e anello premontato



Code	Desc.	Ø tubo D1	Ø tubo D2	Ø tubo D3
1760012590	162022	6	6	6
1760012690	162072	8	8	8
1760013050	162262	16	16	16

## Air connection union to cross for braking systems

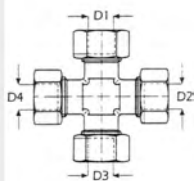

- For pipes and Rilsan.
- Complete with bushings and nuts.

Code	Desc.	Ø tubo D1	Ø tubo D2	Ø tubo D3	Ø tubo D4
1760029400	136002	6	6	6	6
1760029410	136052	8	8	8	8
1760029420	136102	10	10	10	10
1760029430	136152	12	12	12	12

## Air connection bulkhead right for braking systems

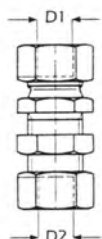

Code	Desc.	Ø tubo D1	Ø tubo D2
1760029500	137002	6	6
1760029510	137052	8	8
1760029520	137102*	10	10
1760029530	137152	12	12
1760029540	137702	14	14
1760029560	255782	16	16
1760029570	137252	18	18
1760029571	137802	20	20
1760029572	137302	22	22

- For pipes and rilsan.
- Complete with bushings and nuts.
- Ideal for spirals like bulkhead (removing nuts and bushings). thread M16x1,5.

## Air connection bulkhead fitting "L" for braking systems

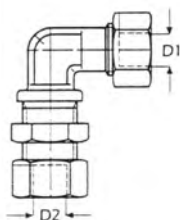

Code	Desc.	Ø tubo D1	Ø tubo D2
1760029600	138002	6	6
1760029610	138052	8	8
1760029620	138102	10	10
1760029630	138152	12	12
1760029640	138202	15	15
1760029660	138252	18	18
1760029665	138802	20	20
1760029670	138302	22	22

- For pipes and Rilsan.
- Complete with bushings and nuts.

## Raccordo a L con dado girevole



Code	Desc.	Ø tubo D1	Ø tubo D2
1760034116	GOG06LACA	6	6
1760034117	GOG08LACA	8	8
1760034118	GOG10LACA	10	10
1760034119	GOG12LACA	12	12
1760034120	GOG16LACA	16	16
1760034121	GOG18LACA	18	18
1760034122	GOG20LACA	20	20

## Connection crossing specific Scania

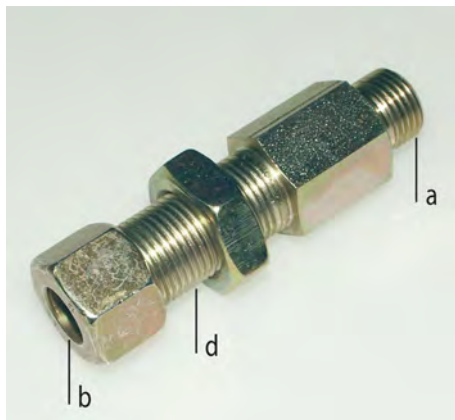

- Complete with bushings and nuts.
- Hexagon increased thickness.
- Specific application for Scania (given the particular location).
- Provided for the passage from a wall and fixing to it.
- Specific for Scania given the particular location.

Code	Desc.	a	b	d
1760029580	137260*	M16X1,5	T12	M18X1,5
1760029590	137270	M22X1,5		

## Connection elbow orientable



- Complete with bushings and nuts.
- It equipped with O-rings under the nut to be orientable.

Code	Desc.	a	b
1760029280	120260	M12X1,5	T8
1760029285	120265	M12X1,5	T10
1760029286	120266	M16X1,5	T10
1760029287	120267	M22X1,5	T10
1760029291	120271	M14X1,5	T12
1760029292	120272	M16X1,5	T12

## Connection elbow orientable bulkhead



- Complete with bushings and nuts.
- It equipped with O-rings under the nut to be orientable.
- Provided for the passage from a wall and fixing to it.

Code	Desc.	a	b
1760029295	120275	M16X1,5	T12

## End connection straight male

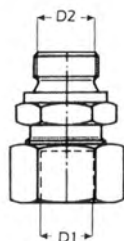

- Complete with bushings and data.

Code	Desc.	Ø tubo D1	Thread D2
1760029700	107002	6	10x1 M
1760029705	107012	6	12x1 M
1760029710	107022	6	12x1,5 M
1760029720	107032	6	14x1,5 M
1760029730	250012	6	16x1,5 M
1760029740	250002	6	22x1,5 M
1760029750	107063	8	10x1 M
1760029760	250032	8	12x1,5 M
1760029770	107072	8	14x1,5 M
1760029780	250042	8	16x1,5 M
1760029790	250062	8	22x1,5 M
1760029800	107112	10	12x1,5 M
1760029810	107102	10	14x1,5 M
1760029820	107122	10	16x1,5 M
1760029830	107132	10	18x1,5 M
1760029840	250152	10	22x1,5 M
1760029850	107192	12	12x1,5 M
1760029860	107162	12	14x1,5 M
1760029870	107152	12	16x1,5 M
1760029890	250212	12	22x1,5 M
1760029892	250214	14	16x1,5 M
1760029894	250216	14	20x1,5 M
1760029896	250218	14	22x1,5 M
1760029900	250222	16	16x1,5 M
1760029920	250224	16	22x1,5 M
1760029930	250226	18	22x1,5 M

## End connection straight female

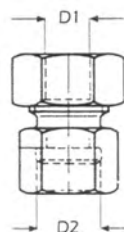

Code	Desc.	Ø tubo D1	Thread D2
1760030000	143002	6	10x1
1760030010	148162	8	16x1,5
1760030020	256182	8	22x1,5
1760030030	143102	10	14x1,5
1760030040	256302	10	22x1,5
1760030050	143152	12	16x1,5
1760030060	256432	12	22x1,5

## Extremity connection "L"

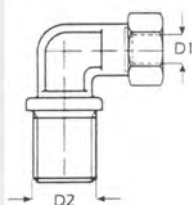

- Complete with bushings and nuts.

Code	Desc.	Ø tubo D1	Thread D2
1760030096	252001	6	10x1 M
1760030100	252002	6	12x1,5 M
1760030110	252032	8	12x1,5 M
1760030120	252062	8	14x1,5 M
1760030130	252092	10	12x1,5 M
1760030140	252122	10	14x1,5 M
1760030150	252252	12	16x1,5 M
1760030152	252262	12	22x1,5 M
1760030160	252432	16	22x1,5 M
1760030170	252452	18	22x1,5 M



## Nut spare connections



Code	Desc.	For pipes Ø ext.
1760014600	004002	6
1760014700	004052	8
1760014800	004102	10
1760014900	004152	12
1760015000	004202	15
1760015200	004252	18
1760015250	004802	20
1760015300	004302	22

## Support sleeves for tubes Rilsan



Code	Desc.	For pipes Ø ext.	Thickness mm
1760017900	022425	6	1
1760018000	022465	8	1
1760018800	022455	8	1,5
1760018100	022495	10	1
1760018900	022485	10	1,5
1760018200	022525	12	1
1760019000	022515	12	1,5
1760018300	022545	14	1
1760019200	022555	15	1,5
1760019720	022605	18	2

## Clamping rings for Rilsan tubes and metal



Code	Desc.	For pipes Ø ext.
1760032600	100020	6
1760032610	100524	8
1760032620	101024	10
1760032630	101524	12
1760032640	107024	14
1760032650	102024	15
1760032660	107524	16
1760032670	102524	18
1760032671	108020	20
1760032672	103020	22

## Condensate drain valve

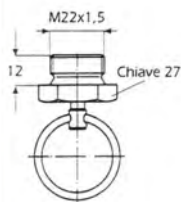

- Air tanks.

Code	Desc.	Tthread
1760032500	258825	22x1,5

## Straight connector series 230 - MERCEDES - DAF - MAN

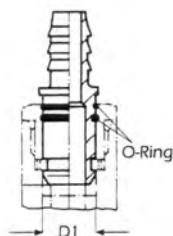

Code	Desc.	Series	For pipe Ø	D1
1760031000	230005	8	4x6	9,4
1760031050	230015	8	6x8	9,4
1760031100	230025	12	4x6	14,9
1760031150	230035	12	6x8	14,9
1760031200	230045	12	9x12	14,9
1760031250	229915	12	12x16	14,9

## Connection "L" series 230 - MERCEDES - DAF - MAN

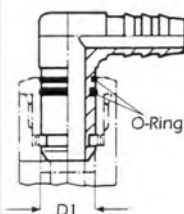

Code	Desc.	Series	For pipe Ø	D1
1760031400	230125	12	4x6	14,9
1760031450	230135	12	6x8	14,9
1760031550	230185	12	12x16	14,9

## Connection "T" series 230 - MERCEDES - DAF - MAN

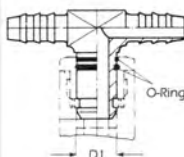

Code	Desc.	Series	For pipe Ø	D1
1760031600	230525	8	4x6	9,4
1760031650	230505	8	6x8	9,4
1760031700	230585	12	4x6	14,9
1760031750	230565	12	6x8	14,9

## Connection 60 ° series 230 - MERCEDES - DAF - MAN

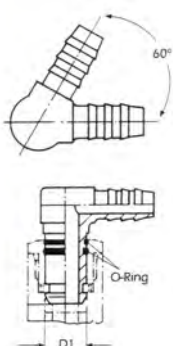

Code	Desc.	Series	For pipe Ø	D1
1760032000	229595	8	8x1	9,4
1760032050	229385	12	8x1	14,9
1760032100	229605	12	12x1,5	14,9

## Place for fitting series 230 - MERCEDES - DAF - MAN

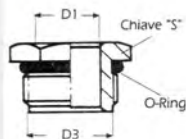

Code	Desc.	Series	Thread D3	Wrench S	D1
1760032200	620299	8	16x1,5	19	9,5
1760032250	620399	12	22x1,5	24	15

## Raccordi istantanei per impianti frenanti

### CARATTERISTICHE E CAMPO D'IMPIEGO

IL RACCORDO ISTANTANEO IN OTTONE VIENE IMPIEGATO CON TUBI IN RILSAN E HYTREL SUI CIRCUITI PNEUMATICI FRENANTI DI AUTOCARRI E RIMORCHI. E' UN RACCORDO SICURO GIA' PRONTO PER L'ACCOPIAMENTO MANUALE CON IL TUBO SENZA DOVER USARE ALCUN UTENSILE. NEL MONTAGGIO RISPETO AI RACCORDI TRADIZIONALI SI HA UN RISPARMIO DI TEMPO PARI AL 70÷80% LE TOLLERANZE DEI TUBI IMPIEGATI DEVONO ATTENERSI A QUANTO STABILITO DALLA NORMA ISO 7628 E DIN 74324-73378. LA TEMPERATURA DI ESERCIZIO E' DI +100° C/-40°C

### ISTRUZIONI DI MONTAGGIO TERMINALE DIRITTO

LA TENUTA DEI TERMINALI DIRITTI SI RIFERISCE A QUANTO STABILITO DALLA NORMA ISO 6149-DIN 3482. PER OTTENERE UN CORRETTO MONTAGGIO SU TUTTI I RACCORDI TERMINALI OCCORRE ATTENERSI SCRUPolosAMENTE AI VALORI DI SERRAGGIO INDICATI NELLA TABELLA

FILETTO	COPPIA SERRAGGIO (Nm) ± 10%
M 10x1	22
M 12x1,5	24
M 14x1,5	30
M 16x1,5	35
M 18x1,5	36
M 22x1,5	40

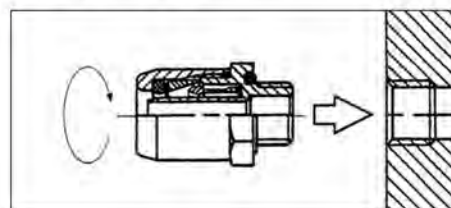

IL TUBO DEVE ESSERE TAGLIATO AD ANGOLO RETTO CON UNA TOLLERANZA MASSIMA DI 15°. IL CORRETTO MONTAGGIO SI REALIZZA SOLO CON L'INSERIMENTO DEL TUBO FINO ALLA BATTUTA NELLA SEDE DEL RACCORDO. PER AVERE L'ASSOLUTA CERTEZZA CHE SI REALIZZI TALE CONDIZIONE E' OPPORTUNO SEGNARE GRAFICAMENTE LA PROFONDITA' D'INNESTO DEL TUBO (QUOTA H)

Ø TUBO	PROFONDITA' DI INNESTO "H"
6x4	19,8
8x6	20,5
10x7	24
12x9	25
15x12	27
16x12	27

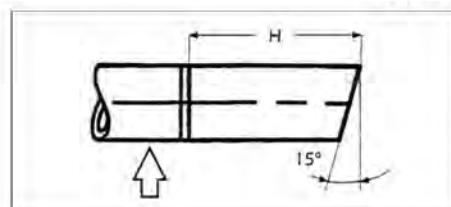

L'INNESTO TUBO-RACCORDO NON NECESSITA' DI UTENSILI. PER AGEVOLARE L'OPERAZIONE E' SUFFICIENTE RUOTARE LIEVEMENTE IL TUBO. LO SFORZO NECESSARIO ALL'INNESTO E' RIPORTATO NELLA SEGUENTE TABELLA.

Ø TUBO	FORZA DI INNESTO "N"
6	60
8	80
10	82
12	95
15	100
16	100

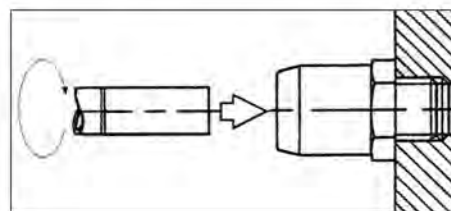

## Terminals rights

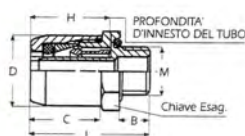

Code	Desc.	Tubo	M	B	D	C	H	L	Ch
1860012000	800210	4x6	10x1	9	15	19,5	19,8	33,5	16
1860012100	800212	4x6	12x1,5	9	15	19,5	19,8	33,5	18
1860012200	800216	4x6	16x1,5	9	15	19,5	19,8	34	22
1860012300	800222	4x6	22x1,5	10	15	19,5	19,8	35,5	28
1860012400	800310	6x8	10x1	9	17	19,7	20,5	34,2	18
1860012500	800312	6x8	12x1,5	9	17	19,7	20,5	34,2	18
1860012600	800314	6x8	14x1,5	9	17	19,7	20,5	34,2	20
1860012700	800316	6x8	16x1,5	9	17	19,7	20,5	34,2	22
1860012800	800322	6x8	22x1,5	10	17	19,7	20,5	35,7	28
1860012900	800412	7x10	12x1,5	9	20	22,5	24	37	20
1860013000	800416	7x10	16x1,5	9	20	22,5	24	37	22
1860013100	800422	7x10	22x1,5	10	20	22,5	24	38,5	28
1860013200	800512	9x12	12x1,5	9	22	23,5	25	38,5	22
1860013300	800516	9x12	16x1,5	9	22	23,5	25	38,5	22
1860013400	800522	9x12	22x1,5	10	22	23,5	25	39,5	28
1860013500	800616	12x15	16x1,5	9	28	25,5	27	42,5	28
1860013600	800622	12x15	22x1,5	10	28	25,5	27	42,5	28
1860013700	800716	12x16	16x1,5	9	28	25,5	27	42,5	28
1860013800	800722	12x16	22x1,5	10	28	25,5	27	42,5	28

## Terminals swivel to 90°

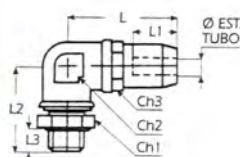

Code	Desc.	Tubo	M	L	L1	L2	L3	Ch1	Ch2	Ch3
1860013900	815210	4x6	10x1	42,5	19,8	33,5	9	19	16	18
1860014000	815212	4x6	12x1,5	42,5	19,8	33,5	9	19	18	18
1860014100	815216	4x6	16x1,5	42,5	19,8	33,5	9	19	22	18
1860014200	815222	4x6	22x1,5	42,5	19,8	34,5	10	19	28	18
1860014300	815310	6x8	10x1	43,5	20,5	33,5	9	19	16	18
1860014400	815312	6x8	12x1,5	43,5	20,5	33,5	9	19	18	18
1860014500	815316	6x8	16x1,5	43,5	20,5	33,5	9	19	22	18
1860014600	815322	6x8	22x1,5	43,5	20,5	34,5	10	19	28	18
1860014700	815412	7x10	12x1,5	46	24	33,5	9	19	18	20
1860014800	815416	7x10	16x1,5	46	24	33,5	9	19	22	20
1860014900	815422	7x10	22x1,5	46	24	34,5	10	19	28	20
1860015000	815512	9x12	12x1,5	50	25	36	9	22	22	22
1860015100	815514	9x12	14x1,5	50	25	36	9	22	22	22
1860015200	815516	9x12	16x1,5	50	25	36	9	22	22	22
1860015300	815522	9x12	22x1,5	50	25	37	10	22	28	22
1860015400	815616	12x15	16x1,5	54	27	36	9	22	22	28
1860015500	815622	12x15	22x1,5	54	27	37	10	22	28	28
1860015600	815716	12x16	16x1,5	54	27	36	9	22	22	28
1860015700	815722	12x16	22x1,5	54	27	37	10	22	22	28

## Terminals swivel to "L"

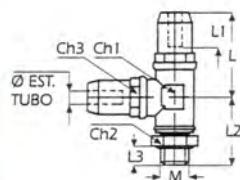

Code	Desc.	Tubo	M	L	L1	L2	L3	Ch1	Ch2	Ch3
1860015800	825210	4x6	10x1	42,5	19,8	33,5	9	19	16	18
1860015900	825212	4x6	12x1,5	42,5	19,8	33,5	9	19	18	18
1860016000	825216	4x6	16x1,5	42,5	19,8	33,5	9	19	22	18
1860016100	825222	4x6	22x1,5	42,5	19,8	34,5	10	19	28	18
1860016200	825310	6x8	10x1	43,5	20,5	33,5	9	19	16	18
1860016300	825312	6x8	12x1,5	43,5	20,5	33,5	9	19	18	18
1860016400	825316	6x8	16x1,5	43,5	20,5	33,5	9	19	22	18
1860016500	825322	6x8	22x1,5	43,5	20,5	34,5	10	19	28	18
1860016600	825412	7x10	12x1,5	46	24	33,5	9	19	18	20
1860016800	825422	7x10	22x1,5	46	24	34,5	10	19	28	20
1860016900	825512	9x12	12x1,5	50	25	36	9	22	22	22
1860017000	825514	9x12	14x1,5	50	25	36	9	22	22	22
1860017100	825516	9x12	16x1,5	50	25	36	9	22	22	22
1860017200	825522	9x12	22x1,5	50	25	37	10	22	28	22
1860017300	825616	12x15	16x1,5	54	27	36	9	22	22	28
1860017400	825622	12x15	22x1,5	54	27	37	10	22	28	28
1860017500	825716	12x16	16x1,5	54	27	36	9	22	22	28
1860017600	825722	12x16	22x1,5	54	27	37	10	22	22	28



### Terminals swivel "T"

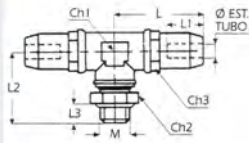

Code	Desc.	Tubo	M	L	L1	L2	L3	Ch1	Ch2	Ch3	
1860017700	835210	4x6	10x1	42,5	19,8	33,5		9	19	16	18
1860017900	835216	4x6	16x1,5	42,5	19,8	33,5		9	19	22	18
1860018000	835222	4x6	22x1,5	42,5	19,8	34,5	10	19	28	18	
1860018100	835310	6x8	10x1	43,5	20,5	33,5		9	19	16	18
1860018200	835312	6x8	12x1,5	43,5	20,5	33,5		9	19	18	18
1860018300	835316	6x8	16x1,5	43,5	20,5	33,5		9	19	22	18
1860018400	835322	6x8	22x1,5	43,5	20,5	34,5	10	19	28	18	
1860018500	835412	7x10	12x1,5	46	24	33,5		9	19	18	20
1860018600	835416	7x10	16x1,5	46	24	33,5		9	19	22	20
1860018700	835422	7x10	22x1,5	46	24	34,5	10	19	28	20	
1860018800	835512	9x12	12x1,5	50	25	36		9	22	22	22
1860018900	835514	9x12	14x1,5	50	25	36		9	22	22	22
1860019000	835516	9x12	16x1,5	50	25	36		9	22	22	22
1860019100	835522	9x12	22x1,5	50	25	37	10	22	28	22	22
1860019200	835616	12x15	16x1,5	54	27	36		9	22	22	28
1860019300	835622	12x15	22x1,5	54	27	37	10	22	28	28	28
1860019400	835716	12x16	16x1,5	54	27	36		9	22	22	28
1860019500	835722	12x16	22x1,5	54	27	37	10	22	22	28	28

### Straight unions

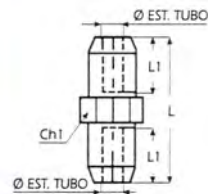

Code	Desc.	Tubo	L	L1	Ch1
1860019600	850200	4x6	47	19,8	18
1860019700	850300	6x8	47,5	20,5	18
1860019800	850400	7x10	53	24	20
1860019900	850500	9x12	56,5	25	22
1860020000	850600	12x15	60,5	27	28
1860020100	850700	12x16	60,5	27	28

### Unions 90 °

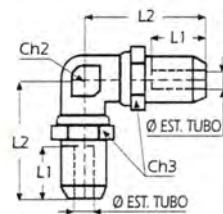

Code	Desc.	Tubo	L	L1	Ch1	Ch2
1860020200	860200	4x6	19,8	42,5	19	18
1860020300	860300	6x8	20,5	43,2	19	18
1860020400	860400	7x10	24	46	19	20
1860020500	860500	9x12	25	50	22	22

## T unions

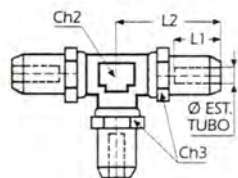

Code	Desc.	Tubo	L	L1	Ch1	Ch2
1860020800	870200	4x6	19,8	42,5	19	18
1860020900	870300	6x8	20,5	43,2	19	18
1860021000	870400	7x10	24	46	19	20
1860021100	870500	9x12	25	50	22	22

## Cross unions

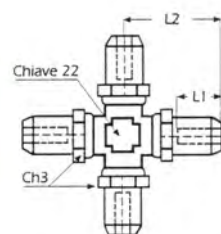

Code	Desc.	Tubo	L1	L2	Ch3
1860021500	880300	6x8	47,5	20,5	18

## Unions straight bulkhead

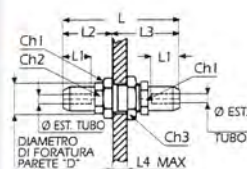

Code	Desc.	Tubo	D	L	L1	L2	L3	L4	Ch1	Ch2	Ch3
1860022000	853200	4x6	19	75	19,8	30,5	44,5	12	18	22	24
1860022100	853300	6x8	19	76,4	20,5	31,2	45,2	12	18	22	24
1860022200	853400	7x10	19	82	24	34	48	12	20	22	24
1860022300	853500	9x12	23	89	25	35,5	53,5	12	22	22	27

## Unions at 90 ° bulkhead

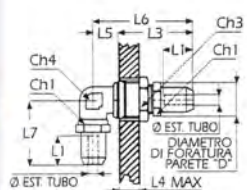

Code	Desc.	Tubo	D	L1	L3	L4	L5	L6	L7	Ch1	Ch2	Ch3	Ch4
1860023000	863600	12x15	23	27	57,5	12	22	80	54	28	27	27	22

## Caps

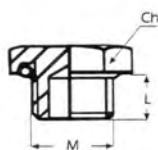

- Prese di pressione pneumatiche maschio a norme ISO 3583

Code	Desc.	M	L	Ch
1860023200	695012	12x1,5	9	18
1860023300	695016	16x1,5	9	22
1860023320	695018	18x1,5	10	24
1860023400	695022	22x1,5	10	28

## Reductions

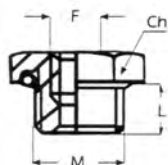

Code	Desc.	M	F	L	Ch
1860023500	696316	16x1,5	12x1,5	9	22
1860023600	696322	22x1,5	12x1,5	10	28
1860023700	696522	22x1,5	16x1,5	10	28

## Pressure taps

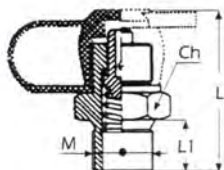

Code	Desc.	M	L	L1	Ch
1860023800	790012	12x1,5	42	10	18
1860023900	790016	16x1,5	40	12	22
1860024000	790022	22x1,5	40	12	27

## Reductions for braking systems



- Reduction for hydraulic systems and braking systems.
- Reduction adapters and connectors to transition from metric thread to gas and vice versa.
- Resistant to high pressures.
- Via these adapters and can use the compressed air braking system for the use of pneumatic tools.

Code	Desc.	Fig.	Tthread
3450008760	263	1	F 16X1,5 - M 1/4 GAS
3450008770	264	2	M 16X1,5 - M 1/4 GAS

## Raccordi per presa di pressione



Code	Description	Tthread	Gas thread	Fig.
1860024050	7022	16x1,5	1/4"	1
3450008771	Adattatore girevole	16x1,5	1/4"	2

## Sistemi ancoraggio telo – sponda con gancio tondo ad uncino e fibbia in acciaio inox



- Sistemi d'ancoraggio telo – sponda con fibbia in acciaio inox e gancio ad uncino
- Prodotto per rimorchi e semirimorchi telonati
- L'art. 4680000040 e' provvisto di chiusura a scatto
- L'art. 4680000035 ha la chiusura a molla
- Disponibile la piastra con viti di fissaggio
- I sistemi d'ancoraggio Meccanocar sono prodotti con fibbie in acciaio inox per una maggiore resistenza e durata del prodotto

Code	Desc.	Article	Fig.	Closing	Width max plate mm	Width belt mm
4680000035	35/M	Ancoraggio a molla gancio unico	A	Molla di sicurezza	58	50
4680000040	35/S	Ancoraggio a scatto gancio unico	B	Chiusura a scatto	67	50
4680000045	35/P	Contropiastra	C	-	-	-

## Sistemi ancoraggio telo – sponda con gancio piatto e fibbia in acciaio inox



- Sistemi d'ancoraggio telo – sponda con fibbia in acciaio inox e gancio piatto (modello tedesco)
- Prodotto per rimorchi e semirimorchi telonati dei principali allestitori europei
- L'art. 4680000050 e' provvisto di chiusura a scatto
- L'art. 4680000055 ha la chiusura a molla
- I sistemi d'ancoraggio Meccanocar sono prodotti con fibbie in acciaio inox per una maggiore resistenza e durata del prodotto

Code	Desc.	Article	Fig.	Closing	Width max plate mm	Width belt mm
4680000050	36/S	Ancoraggio a scatto gancio piatto	A	Chiusura a scatto	65	50
4680000055	36/M	Ancoraggio a molla gancio piatto	B	Chiusura a molla di sicurezza	58	50
4680000045	35/P	Contropiastra	C	-	-	-



## Sliding carriages tarpaulins 2 bearings



- Sliding carriages tarpaulins for banks.
- Trolley with 2 stainless steel bearings with big plate.
- Products for hauliers.
- The trolleys are fixed through a special counter and rivets diameter 5 mm (not included).
- Wheels of 24 mm diameter.
- The wheels metallic material allow a remarkable resistance of the product without damaging the rails.

Code	Desc.	Article
468000065	37/C	Trolley with 2 bearings
468000070	37/P	Large counterplate

## Sliding carriages tarpaulins 2-bearing plate small



- Sliding carriages tarpaulins for banks.
- Cart 2-bearing plate with small.
- Products for hauliers.
- The trolleys are fixed through a special counter and rivets diameter 5 mm (not included).
- Wheels of 24 mm diameter.
- The wheels metallic material allow a remarkable resistance of the product without damaging the rails.

Code	Desc.	Article
468000075	38/C	Shopping in small plate
468000080	38/P	Small counterplate

## Sliding carriages tarpaulins 4 bearing plate bent



- Tarpaulins for trucks slip bands.
- 4 bearing carriage with folded plate.
- Truck products.
- The carts are secured by the corresponding counterplate and 5mm diameter rivets.

Code	Desc.	Article
468000085	39/C	Carriage 4 bearings
468000090	39/P	Counterplate

## Jumper Belt 2 holes

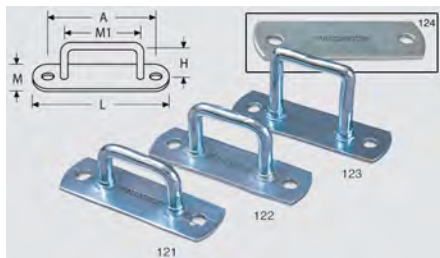

- In acciaio zincato.

Code	Desc.	Misure mm H-L-M-A-M1
4860000300	121-15	15 66 20 51 25
4860000310	122-20	20 66 20 51 25
4860000320	123-30	30 66 20 51 25
4860000330	124	Counterplate 66x20

## Jumper for banks 2 holes



- Galvanized steel.

Code	Desc.	h mm
4860000340	125-25	25

## CAVALLOTTO A 2 FORI A PIPA



- In acciaio zincato.

Code	Description	H mm
4860000348	126-30	30
4860000349	126-P	CONTRO PIASTRINA 56x72

## Hook-nose edge



- Galvanised iron.

Code	Desc.
4860000520	308

## GANCIO SPONDA DIRITTO



- In ferro zincato

Code	Description	Dimens. (mm)
4860000500	305-72x20	20x72x20

## GANCI PER SPONDE



- In nylon

Code	Description	Dimens. (mm)
4860001060	727-N nero	41x39
4860001070	727-B bianco	41x39

## GANCIO A S GIRATO



- In ferro zincato

Code	Description	Dimens. (mm)
4860001090	729-4	45x4

## GANCIO A S CHIUSO



- In ferro zincato

Code	Description	Dimens. (mm)
4860001080	728-4	50x4

## Hook "S"

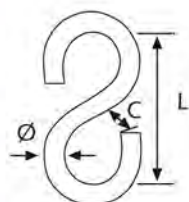

- Acciaio zincocromato.
- Utilizzabile con la nostra catena genovese.

Code	Desc.	Ø mm	L mm	C mm	Color
1550011000	3-GS	3	28	3,5	WHITE
1550011010	4-GS	4	32	4	WHITE
1550011030	6-GS	6	50	7	WHITE

## GANCIO ZIG-ZAG APERTO



- Per chiusura teloni tramite corde.

Code	Description	Measure mm
4860000530	311	63x20X20
4860000550	313-Piastrina di supporto	36x20

## GANCIO ZIG-ZAG APERTO 3 fori



- Per chiusura teloni tramite corde.
- Gancio e piastrina in nylon.

Code	Description	Measure mm
4860000522	309	60x35

## GANCIO APERTO A "T" BIANCO



- In nylon

Code	Description	H mm
4860000535	311-T	60x20
4860000550	313 - Piastrina di supporto	36x20

## GANCIO IN NYLON CHIUSO TIPO "C"



- In nylon

Code	Description	Dimens. (mm)
4860000540	312	61x20X22
4860000550	313-Piastrina di supporto	36x20

## GANCIO IN NYLON PICCOLO PER SPONDE



- Per sponde autocarro.

Code	Description	Dimens. (mm)
4860000570	315	26x45x38

## Small triangle hook



- Truck edge.
- Nylon hook.
- In closing tarpaulins by means of ropes.

Code	Desc.	Measure mm
4860000560	314	28x47x39

## Medium hook with hole



- Truck edge.
- Nylon hook for closing tarpaulins by means of ropes.

Code	Desc.	Measure mm
4860000580	316	30x55x45

## Hook with round hole



- For banks truck.
- Nylon hook for closing tarpaulins bracings.

Code	Desc.	Measure mm
4860000590	317	30x55x47

## Rivet for nylon hooks n / s art. 486-311



- With brass head nickel - shank l. mm 10.

Code	Desc.	Measure mm
4860000620	332	3x10x11 T11

## Cable T.I.R. with nylon core



- Nylon core.
- Exterior PVC treated antifreeze.
- Roll of 100 meters.

Code	Desc.	Ø est.	Ø internal	Lung. mt
4860000420	253	8	4	100
4860000430	254	6	3	100
4860000434	254-34	6	-	34

## Nylon rope white



- Roll of 100 meters.
- Treated to ultraviolet.

Code	Desc.	Ø
4860000639	404-6	6
4860000640	404-8	8
4860000642	404-10	10

## Rope-blocks Necklaces



- Fascette in ferro zincato.

Code	Desc.	Length mm
4860000600	321	12
4860000610	322	25



## Elastic rope



- High resistance.
- Rubber Soul.

Code	Desc.	Ø	Color	Length mt
4860000660	522-8	8	RED	100
4860000670	523-8	8	GREEN	100
4860000680	524-8	8	BLUE	100
4860000690	525-8	8	GREY	100
4860000665	522-6	6	RED	300
4860000675	523-6	6	GREEN	300
4860000685	524-6	6	BLUE	300
4860000695	525-6	6	GREY	300

## Hook elastic rope basket



- Completo di ranella.
- In ferro zincato.
- Per fune diametro 6 e 8 mm.

Code	Desc.
4860000510	307

## Black canvas tensioner elastic



- Completo di gancio a cestello.

Code	Desc.	Measure cm
4860000700	551	20
4860000710	552	30

## Black canvas tensioner rubber



- In pura gomma.

Code	Desc.	Measure cm
4860000720	555	20
4860000740	557	40

## TUBETTO DESMOPAN IN PVC ELASTICIZZATO



- Tubetto diam 7 Pieno

Code	Desc.	Diam. mm	Color	Length m
4860000697	550-7	7	BIANCO	150

## Cable terminals T.I.R.



- Completo di occhiello e chiodo in acciaio.
- Per cavi diametro 6 e 8 mm.

Code	Desc.	Ø
4860000440	255-8	8
4860000450	256-6	6

## Punch for cable lugs T.I.R.



- Complete with accessories for cable diameter 6 to 8 mm.

Code	Desc.	Ø
4860000460	257-8	8
4860000465	257-6	6

## CAVO TIR IN ACCIAIO CON RIVESTIMENTO IN NYLON



- Rotolo da 100 metri.
- Trattata ai raggi ultravioletti

Code	Desc.	Dimens. (mm)	Lung. mt
4860000435	254-6	6	100
4860000438	254-8	8	100

## CAVO TIR ACCIAIO CON CAPOCORDA



- Fascette in ferro zincato

Code	Desc.	Dimens. (mm)	Lung. mt
4860001010	701-33	6	33
4860001020	702-34	6	34
4860001024	701-40	6	40

## CAVO TIR ACCIAIO ANTI-GIRO



- 133 fili in acciaio zincato.
- Per copri-scopri.

Code	Desc.	Dimens. (mm)	Length mt
4860001000	600-6	6	100
4860001008	600-8	8	100

## CINTURINI IN PVC



- Colore grigio

Code	Desc.	Dimension cm
4860001030	725-25	25x2,1 cm
4860001040	725-40	40x2,1 cm

## CINGHIE IN PVC



- Cinghia TIR in pvc trasparente

Code	Description	Dimensions
4860001050	726-22	50m x22mm

## Adhesive Tape Velcro Male + Female



- White color.
- Black Colour.
- Adhesive base.



Base adesiva



Tipo tenace

Code	Desc.	Dim. LxH. cm	Color
4720018796	789/1B	20mmx25m	WHITE
4720018797	789/2B	25mmx25m	WHITE
4720018798	789/3B	50mmx25m	WHITE
4720018791	789/1N	20mmx25m	BLACK
4720018792	789/2N	25mmx25m	BLACK
4720018793	789/3N	50mmx25m	BLACK

## OCCHIELLI ROTONDI IN ALLUMINIO



- Per teloni.

Code	Description	Dimensione mm
4860000742	906-10	10x20x5,5
4860000744	906-16	16x30x7,1
4860000750	906-18	18x34x7,5
4860000752	906-24	24x49x10
4860000758	906-40	40x62x11

## OCCHIELLI ROTONDI IN ALU-ZINK



- Per teloni.

Code	Description	Dimension Ø X Width mm
4860000770	910-38	38x62x13

## OCCHIELLI OVALI



- Per teloni

Code	Description	Dimens. (mm)	Material
4860000760	909-42	42x22	Alluminio
4860000762	909-40	40x20	Aluzink

## PUNZONI A MARTELLO TONDI

- Per chiudere gli occhielli tondi dei teloni



Code	Description	For eyelets Ø
4860000792	1906-10	10
4860000796	1906-16	16
4860000800	1906-18	18
4860000804	1906-24	24
4860000820	1910-40	38

## PUNZONI MARTELLO OVALI

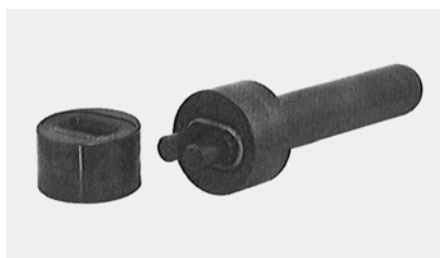

- Per chiudere gli occhielli ovali dei teloni.

Code	Description	For eyelets Ø
4860000810	1909-42	42x22
4860000808	1909-40	40x10

## TARPAULINS DIE FOR ROUND EYELETS



Code	Description	Ø mm
4430044710	510-2	2
4430044712	510-4	4
4430044714	510-6	6
4430044716	510-8	8
4430044718	510-10	10
4430044720	510-12	12
4430044722	510-14	14
4430044724	510-16	16
4430044726	510-18	18
4430044735	510-20	20
4430044740	510-24	24
4430044742	510-26	26
4430044743	510-28	28
4430044745	510-30	30
4430044760	510-40	40

- Die forged steel.
- Polished head painted body.

## FUSTELLE PER TELONI PER OCCHIELLI OVALI



- Fustella in acciaio forgiato.

Code	Description	Dimens. (mm)
4860000858	2909-40	40x10
4860000860	2909-42	42x22

## COLLA PER TESSUTO IN PVC



- Per teloni

Code	Description	Content ml
4110019970	319	200



## Adhesive tape for repairing tarpaulins



- Adhesive tape for quick repair, simple and durable tarpaulins for trucks, both on the road and in the workshop.
- It is usable without the use of glue, hot air tool or other equipment to make repairs. It can also be used for events of tents, caravans, marine industry or other sheeting coated with PVC.
- It is fabricated with the same material used in the production of the sheets and, together with the layer of glue, represents a very high adhesive power and a resistance to temperatures from -40 ° C up to + 80 ° C.
- Working temperature: -15 ° C to + 40 °.
- All tapes have a width of 5 cm and a length of 5 meters.
- **Attention:** just applied on the canvas becomes almost impossible to remove the tape to make corrections of the position.
- **How to use:**

1. Clean the area to be repaired so that no dirt, dust and grease. In addition, the area to be repaired must be dry.
2. Cut the appropriate measures for the repair and remove the protective film. It is advisable to round the four corners with scissors or a utility knife.
3. Glue the patch on the tarpaulin with no creases and exert pressure, possibly by pressing with a flat object.

Code	Desc.	Color	RAL
4060007000	19295	WHITE	9016
4060007010	19295-H100	WHITE	9016
4060007100	19296	GREY	7038
4060007200	19297	BLUE	5002
4060007210	19297-H100	BLUE	5002
4060007300	19298	RED	3002
4060007400	19299	SILVER	9006
4060007500	19300	GREEN	6026
4060007600	19301	YELLOW	1003

## KIT FOR TARPAULINS



- Leister product.
- Hot air gun with accessories.
- With spout 20mm.

Code	Description
4170008320	731-20

## Manual pressure roller for hot air tool



- Pressure roller manual useful to crush the material evenly heated to bond.
- Indicated for the gluing strips of any material and of tarpaulins PVC.

Code	Desc.
417RC01350	56

## Electrical coils polyurethane 24V - 7 poles (ISO 1185 - DIN 72579)



- Electrical connection between tractor and semitrailer.
- Soft material for excellent extensibility at high temperatures.
- Excellent resistance to weathering and chemicals.
- Diameter of coil x reduction reduced footprint.
- Working length: 3.5 m - section cables: n. 6x1 sq mm + n. 1x1,5 sq mm.

Code	Desc.	Characteristics
3170200170	12F - TP-PUR	POLYURETHANE SPIRAL
3170200105	8F - TP	PLUG PARTS WITH CONNECTIONS TERMINALS

## Electrical coils polyurethane 24V - 7 poles (ISO 3731)



- Electrical connection between tractor and semitrailer.
- Soft material for excellent extensibility at low temperatures.
- Excellent resistance to weathering and chemicals.
- Diameter of coil x reduction reduced footprint only 40 mm ext.
- Working length: 3.5 m - section cables: n. 6x1 sq mm + n. 1x1,5 sq mm.

Code	Desc.	Characteristics
3170200175	12M - TP-PUR	POLYURETHANE SPIRAL
3170200115	8M - TP	PLUG PARTS WITH CONNECTIONS TERMINALS

## Electrical coils polyurethane 24V - 7 poles (ISO 1185 - DIN 72579)

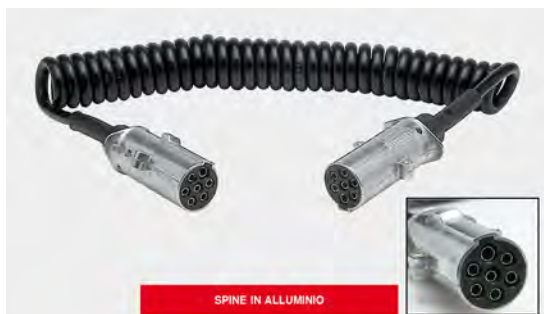

- Electrical connection between tractor and semitrailer.
- Soft material for excellent extensibility at low temperatures.
- Excellent resistance to weathering and chemicals.
- Diameter of coil x reduction reduced footprint only 40 mm ext.
- Working length: 3.5 m - section cables: n. 6x1 sq mm + n. 1x1,5 sq mm.

Code	Desc.	Characteristics
3170200180	13F - ALL-PUR	POLYURETHANE SPIRAL
3170200125	80F - ALL	PLUG PARTS WITH CONNECTIONS TERMINALS

## Electrical coils polyurethane 24V - 7 poles (ISO 3731)



- Electrical connection between tractor and semitrailer.
- Soft material for excellent extensibility at low temperatures.
- Excellent resistance to weathering and chemicals.
- Diameter of coil for reduced footprint reduction only 40 mm ext.
- Working length: 3.5 m - section cables: n. 6x1 sq mm + n. 1x1,5 sq mm.

Code	Desc.	Characteristics
3170200185	13M - ALL-PUR	POLYURETHANE SPIRAL
3170200135	80M - ALL	PLUG PARTS WITH CONNECTIONS TERMINALS

## Short adapter 15-pin 24V



- Adapter with 15-pin plug (ISO 12098) and 7-pin connectors (ISO 1185-ISO 3731).
- Used when driving with a 15-pin socket must be attached to a semi-trailer with 7-pin plugs.
- Simple mounting.
- Its small footprint allows an ideal connection in cases where between tractor and trailer space is limited.
- Used by: VI workshops, fleets, conveyors, body transformation.

Code	Desc.	Characteristics
3170200190	15	SHORT ADAPTER 15/7 + 7

## Adattatore micro 24v



- Spina 15 poli +2 prese 7P N/S
- Modello ultra compatto
- Norma iso 12098/1185/3731

Code	Description
3170200191	15M adattatore micro

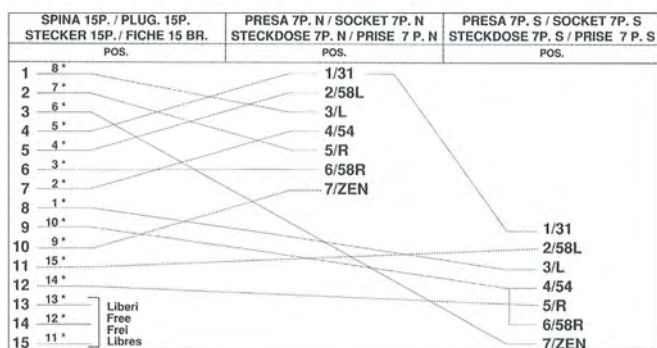

## Spiral adapter



- Adapter / spiral for connecting the drive with 15-pin socket and trailer with 7-pin connectors.
- The same adapter is used for the opposite solution.
- Working length = 4.5 m.
- Article that allows + connections of between 15 and 7 pole in reduced times.
- Used by: drivers, fleets, body transformation, workshops VI.



Code	Desc.	Characteristics
3170200195	16	Adapter / SPIRAL

## Bi-spirale in poliuretano d.20mm



- Spina 15 poli+2 spine 7 poli -24V
- Lunghezza 3,5 metri
- **Versione per IVECO**

Code	Description
3170200196	16/20 I-bi-spirale Iveco

## Bi-spirale in poliuretano d.20mm



- Spina 15 poli+2 spine 7 poli -24V
- Lunghezza 3,5 metri
- **Versione per MERCEDES**

Code	Description
3170200197	16/20 M-bi-spirale Mercedes

## Spiral 15-pin 24V power



- Electrical connection between tractor and trailer (ISO 4141).
- Hytrel cable  $\varnothing$  13.5 mm and st.
- Section wires: 2x1 sq mm + 10x1,5 mm<sup>2</sup> + 3x2.5 sq mm.
- Working length = 3.5 m.
- Spiral with a reduced diameter, designed to reduce clutter and entanglement.
- Used by: drivers, workshops VI, body transformation, fleets.

Code	Desc.	Characteristics
3170200280	32	SPIRAL 15 POLES 24V

## Presse e spina 15poli 24V



- Contatti a vite -cavo d.15,5mm per la presa
- Contatti a vite -cavo d.15/17 per la spina
- A norma ISO 12098

Code	Description
3170200281	32F presa 15poli -24v
3170200282	32m spina 15poli 24v



## Presa 15poli 24V parcheggio



- Corpo in plastica
- Conforme alla norma ISO 12098

Code	Description
3170200284	32P-presa parcheggio

## Spiral for "ABS" 24V



- Electrical coiled cable ABS ADR / GGVS tractor semitrailer for connection (ISO 4141).
- Used to connect the braking system with ABS (5-pin).
- Polyurethane cable  $\varnothing$  13.5 mm and east sect. cables =  $2 \times 4 \text{ mm}^2 + 3 \times 1.5 \text{ sq mm}$ .
- Working length = 3.5 m.
- Spiral of excellent quality, fitted in the first plant, small footprint of the spiral.
- Used by: drivers, fleets, workshops VI, body transformation.

Code	Desc.	Characteristics
3170200200	17	SPIRAL ABS 24V

## 24V sockets - 7 pole



- He took spare for trucks, trailers and semitrailers.
- Sockets with lamellar attacks.
- Easy to change without tools.
- Used by: VI workshops, fleets, body transformation, hauliers.

Code	Desc.	Characteristics
3170200285	33M - TP	JACK 7 POLES THERMOPLASTIC

## 24V sockets - 7 pole



- He took spare for trucks, trailers and semitrailers.
- Sockets with lamellar attacks.
- Easy to change without tools.
- Used by: VI workshops, fleets, body transformation, hauliers.

Code	Desc.	Characteristics
3170200290	33F - TP	JACK 7 POLES THERMOPLASTIC



## 24V sockets - 7 pole



- He took spare for trucks, trailers and semitrailers.
- Sockets with lamellar attacks.
- Easy to change without tools.
- Used by: VI workshops, fleets, body transformation, hauliers.

Code	Desc.	Characteristics
3170200295	34M - ALL	JACK 7 POLES ALUMINIUM

## 24V sockets - 7 pole



- He took spare for trucks, trailers and semitrailers.
- Sockets with lamellar attacks.
- Easy to change without tools.
- Used by: VI workshops, fleets, body transformation, hauliers.

Code	Desc.	Characteristics
3170200300	34F - ALL	JACK 7 POLES ALUMINIUM

## Plug to "ABS" 24V



- Plug 5-pole "ABS" ISO / DIN 7638.1.
- Plug with electrical contacts to clamp in nickel-plated brass.
- Easy to change without tools.
- 2 models for the different outer diameters of the cable.

Code	Desc.	Characteristics
3170200205	18 S	PLUG FOR CABLES X CAVI Ø 15÷17 mm
3170200210	19 S	PLUG FOR CABLES Ø 11.5 to 14.5 mm



## Kit electrical contacts for plug "ABS" 24V



- Contacts to clamp spare.
- Easy tightening of the wire without special tools.
- 5-piece kit.
- 2x6 + 3x1,5 mm<sup>2</sup>

Code	Desc.	Characteristics
3170200215	20 KIT	KIT 5 PIECES

## Socket for "ABS" 24V



- 5-pin socket "ABS" ISO / DIN 7638.
- Taken with electrical contacts to clamp in nickel-plated brass.
- Easy to change without tools.
- 2 models for the different outer diameters of the cable.

Code	Desc.	Characteristics
3170200220	21P	JACK CABLE ø 15.5
3170200225	22P	JACK CABLE ø 7 ÷ 12

## Kit electrical contacts for socket "ABS" 24V



- Contacts to clamp spare.
- Easy tightening of the wire without special tools.
- 5-piece kit.
- 2x6 + 3x1,5 mm<sup>2</sup>

Code	Desc.	Characteristics
3170200230	23 KIT	KIT 5 PIECES

## Spiral "EBS" 24V



- Electrical coiled cable EBS ADR / GGVS connection for truck / trailer (ISO 4141).
- Used to connect the braking system with EBS (7-pin).
- Hytel cable OD 13.5 mm section. cables = 2x4 mm<sup>2</sup> + 3x1.5 mm<sup>2</sup> + 1x (2x1.5 sq mm).
- Used by: VI workshops, fleets, drivers, body transformation.
- NB: spiral with two poles in the spiral more "ABS" whose contacts n ° 6 and n ° 7 are intended for data transmission.



Code	Desc.	Characteristics
3170200235	24	SPIRAL EBS

## Plug "EBS" 24V



- 7 pin plug "EBS" ISO / DIN 7638-1.
- Plug with electrical contacts to clamp in nickel-plated brass.
- Two models for the different outer diameters of the cable.

Code	Desc.	Characteristics
3170200240	25S	PLUG FOR CABLE $\varnothing$ 15 ÷ 17 mm
3170200245	26S	PLUG FOR CABLES $\varnothing$ 11.5 to 14.5 mm

## Kit electrical contacts for plug "ABS" 24V



- Contacts to clamp spare.
- Easy tightening of the wire without special tools.
- Kit 7 pieces.
- 2x6 + 5x1,5 mm<sup>2</sup>

Code	Desc.	Characteristics
3170200250	27 KIT	Kit 7 pieces.

## Socket for "EBS" 24V



- Socket 7-pin "EBS" ISO 7638-1 - ISO / DIN 7638.
- Taken with electrical contacts to clamp in nickel-plated brass.
- Easy to change without tools.
- 2 models for the different outer diameters of the cable.

Code	Desc.	Characteristics
3170200255	28 P	JACK CABLE $\varnothing$ 15.5
3170200260	29 P	JACK CABLE $\varnothing$ 7 ÷ 12

## Kit electrical contacts for socket "ABS" 24V



- Contacts to clamp spare.
- Easy tightening of the wire without special tools.
- Kit 7 pieces.
- 2x6 + 5x1,5 mm<sup>2</sup>

Code	Desc.	Characteristics
3170200265	30 KIT	KIT 7 PIECES

## Spina volante 2 poli 5A



- Spina volante a due poli per basse tensioni (12 – 24 Volts) utilizzabile per l'alimentazione di apparecchi con consumo massimo di 5 Ampere.
- Indicata per l'utilizzo su tutti i tipi di mezzi nel settore dell'autotrasporto, soccorso stradale, movimento terra, nautica, mezzi agricoli, mezzi di soccorso, ecc.
- Costruzione in nylon resistente alle intemperie ed al salmastro, rispondente alla normativa DIN 9698, contatti in acciaio stagnato antiossidazione, fissaggio dei cavi tramite terminali elettrici cilindrici tipo il nostro codice 317 00 15800.
- Utilizzo con la presa da pannello a 2 poli nostro codice 3170200410-02.

Code	Desc.
3170200400	01



## Presca stagna da pannello 2 poli 5A



- Presca stagna con fissaggio a pannello a due poli per basse tensioni (12 – 24 Volts), con cappuccio di protezione a molla, creata come presa di corrente per bassi consumi fino a 5 Ampere.
- Indicata per l'utilizzo su tutti i tipi di mezzi nel settore dell'autotrasporto, soccorso stradale, movimento terra, nautica, mezzi agricoli, mezzi di soccorso, ecc.
- Costruzione in nylon resistente alle intemperie ed al salmastro, rispondente alla normativa DIN 9698, contatti in acciaio stagnato antiossidazione, fissaggio dei cavi tramite terminali elettrici cilindrici tipo il nostro codice 317 00 15800.
- Utilizzo con la spina volante a 2 poli nostro codice 317 02 00410-02.

Code	Desc.
3170200410	02



## Presa a 2 poli 12-24 V



- Con contatti a vite
- Per fissaggio esterno
- Corpo in alluminio

Code	Description
3170200420	Pres a 2 poli fissaggio esterno

## Pres a 2 poli per interni 12-24V



- In ottone nichelato
- Contatti faston da 6,3
- Con coperchio
- SPECIFICA IVECO 4790609
- Per apparecchi ausiliari come lampade di ispezione

Code	Description
3170200430	Pres a 2 poli fissaggio interno

## Spina a 2 poli 12-24V



- In plastica
- Contatti a vite

Code	Description
3170200440	Spina 2 poli in plastica



## 6-24V 3-pin connections (DIN 9680) plugs and socketse



- The connection system, 3-pin (in accordance with DIN 9680) is used on tractors and farm equipment for the electrical connection of mowers, backhoes for construction and sweepers, with a maximum current of 25A.
- This type of connection is not suitable for powering light devices (see ISO 1724 7-pole connections).



6,35  
ATTACCHI POSTERIORI  
LAMELLARI

Code	Description	Photo
3170200500	JACK TPU 3 POLES 6-24V DIN 9680	1
3170200505	PLUG TPU 3 POLES 6-24V DIN 9680	2

## Connections 7-pin 12v (ISO 1724) Aluminum plugs and sockets



- The system connection 7-pin 12v under ISO 1724 is the most widespread system for the electrical connections between tractor and trailer or for connection of additional tools with on-board network from 12v.
- Convenient system for simple applications.
- Easy assembly.
- Contacts with screw connection



Code	Description	Photo
3170200520	52 F-JACK ALUMINIUM 7 POLES 12V ISO 1724	1
3170200525	52M-PLUG ALUMINIUM 7 POLES 12V ISO 1724	2

## Connections 7-pin 12v (ISO 1724) TPU plugs and sockets



- The system connection 7-pin 12v under ISO 1724 | DIN 72577 is the most widespread system for the electrical connections between tractor and trailer or for connection of additional tools with on-board network from 12v.
- Convenient system for simple applications.
- Easy assembly.
- Connection with screw terminals.



Code	Description	Photo
3170200530	53F- TPU JACK 7 POLES 12V ISO 1724	1
3170200535	53M-TPU PLUG 7-POLE 12V ISO 1724	2

## Spirals 7-pin 12v (ISO 1724)



- The system connection 7-pin 12v under ISO 1724 is the most widespread system for the electrical connections between tractor and trailer or for connection of additional tools with on-board network from 12v.
- Polyurethane spirals Treaty coferisce an excellent resistance to chemicals, weathering, heat and light.
- Excellent properties rewind.
- Available with plastic plugs or aluminum.



Code	Description	Ø cavo mm	L m	Ø Est. spirale	Composizione cavo (n° x sez.)
3170200540	54T-SPIRAL TPU 7 POLES 12V WITH PLUGS TPU	9 mm	3	19 mm	6 x 1-1x1,5 mmq
3170200545	54A-12V SPIRAL TPU 7 POLES WITH ALUMINIUM PLUGS	9 mm	3	19 mm	6 x 1-1x1,5 mmq

## 7-13 pin adapter 12v



- Adapter 7-pin plug (ISO 1724) on the tractor to the 13-pin connector (ISO 11446) on the trailer cable.
- Robust plastic body with high mechanical strength.



Code	Description
3170200547	54AD-TPU ADAPTER JACK PLUG 7-POLE 12V 13

## Connections 13-pin 12v (ISO 11446) plugs and sockets



- The connection system 13-pin 12v allows, thanks to the high number of poles compared with the 7-pole system, the transmission of all the lighting functions and additional through only one connector. The system replaces more and more the older generation of connectors, thanks to its advantages, also as regards the sealing, the stability, safety of contact. sturdy plastic body with high mechanical strength.
- Easy assembly.
- Contacts with screw connection.



Code	Description
3170200550	55F-TPU JACK 13 POLES 12V DIN 11446
3170200555	55M- TPU PLUG 13 POLE 12V DIN 11446

## Presa 13 poli 12V



- Con stacco retronebbia con micro interruttore
- Contatti a vite in ottone nichelato
- Conforme alla norma Din 72570 Iso 11446
- Il micro interruttore consente l'accensione del faretto retronebbia dalla vettura a quello del rimorchio o caravan

Code	Description
3170200556	56F -presa 13poli 12v con microint.

## INTERRUTTORI STACCABATTERIE AD AZIONAMENTO MANUALE

Sono denominati anche interruttori generali di corrente , nei quali l'apertura o la chiusura dei contatti avviene mediante l'azionamento di una leva metallica, di una chiave o di un pomello .

Possono essere utilizzati indifferentemente su impianti elettrici a 12v o a 24v e possono interrompere il polo positivo( + )o il polo negativo ( - )

Possono essere utilizzati anche in maniera impropria come antifurti....se montati non a vista e soprattutto i modelli che hanno il sistema di azionamento estraibile.

## Battery switch 100A



- Isolators are "security products", their main function is to remove power to the electrical system of the vehicle by breaking the link between the battery and users. The purpose is to:
- Protect the electrical system in the event of a short circuit.
- Perform maintenance or repairs safely.
- Reduce the self-discharge of the battery when the vehicle is not used for a long time. Choosing the correct battery switch must be made in relation to the amperage of the battery of the vehicle.
- Battery disconnect switch with removable key and rubber cap.
- Scope: cars, small boats, small agricultural vehicles and caravans.

Code	Desc.
3200008000	8000

Technical Features	
Contact nuts	M8 Galvanized steel
Tensione nominale	Max 24 V
Maximum continuous current	100 A
Maximum short time current	500 A x 5 sec
Protection rating	IP 43
Contacts	Copper
Temperatura d'impiego	- 40°C / + 50° C

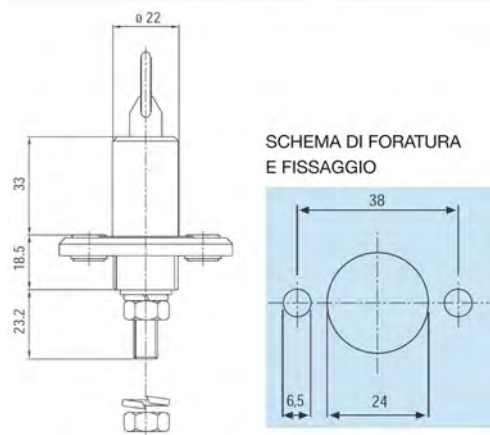

Spare Parts		
Accessories	Code	Description
Switching lever with gasket	3200008010	8010

## Battery switch 150A



- Con chiave estraibile e cappuccio in gomma

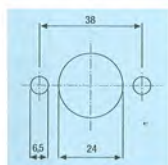
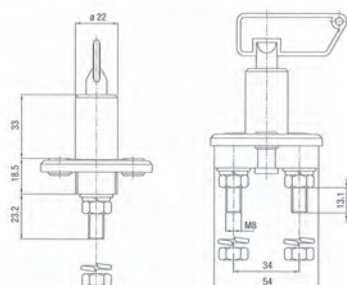

SCHEMA DI FORATURA E FISSAGGIO

Code	Desc.
3200008015	8015

Tecnical Features	
Contact nuts	M10 in acciaio zincato
Contacts	In rame
Temperatura d'impiego	-30°C +60 ° C
Protection rating	IP43
Maximum short time current	1000A x 5 sec
Tensione nominale	Max 24V
Maximum continuous current	150A

Spare Parts	
Code	Description
3200008010	Leva di commutazione con guarnizione

## Battery switch 150A



- Con pomello
- Il vantaggio di questo modello è che può essere azionato anche con il piede.

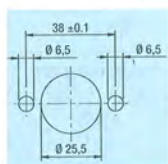
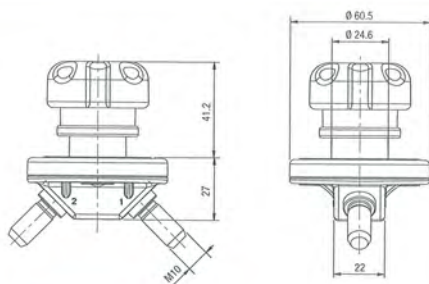

SCHEMA DI FORATURA E FISSAGGIO

Code	Desc.
3200008016	8016

Tecnical Features	
Contact nuts	M10 in ottone
Contacts	In rame argentato
Temperatura d'impiego	-30°C +60 ° C
Protection rating	IP65
Maximum continuous current	150A
Maximum short time current	1200A x 5 sec
Tensione nominale	Max 24V



## Battery switch 150A



- Con chiave estraibile e cappuccio in gomma
- Con 4 contatti supplementari per il montaggio di indicazioni luminose

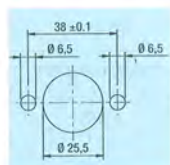
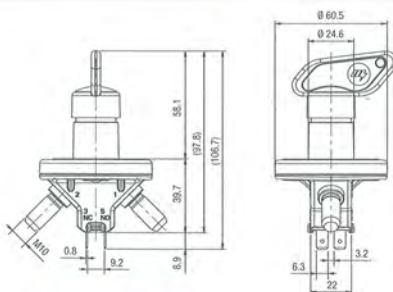

SCHEMA DI FORATURA  
E FISSAGGIO

Code	Desc.
3200008017	8017

Tecnical Features	
Contact nuts	M10 in ottone
Contacts	In rame argentato
Temperatura d'impiego	-30°C +60 ° C
Protection rating	IP65
Maximum continuous current	150A
Maximum short time current	1200A x 5 sec
Tensione nominale	Max 24V

Spare Parts	
Code	Description
3200008030	Leva di commutazione
3200008040	Cappuccio di protezione

## Battery switch 150A



- Battery disconnect switch with actuation by key removable.
- Scope: cars, marine engines, trucks, agricultural vehicles and caravans.

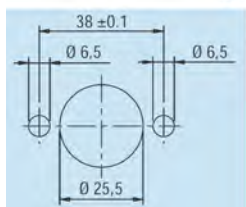
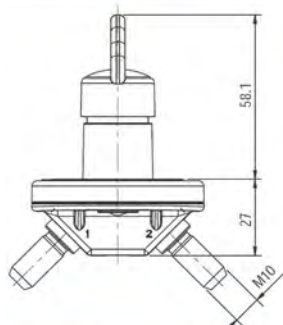

SCHEMA DI FORATURA  
E FISSAGGIO

Code	Desc.
3200008020	8020

Tecnical Features	
Contact nuts	M10
Contacts	Silver-plated copper
Tensione nominale	Max 24 V
Maximum continuous current	150 A
Maximum short time current	1200 A x 5 sec
Temperatura d'impiego	- 30°C / + 60° C
Protection rating	IP 65

Spare Parts		
Accessories	Code	Description
Switching lever spare	3200008030	8030
Cap with eyelet for key	3200008040	8040

## Battery switch 200A



- Con chiave estraibile
- Omologato RINA 8846

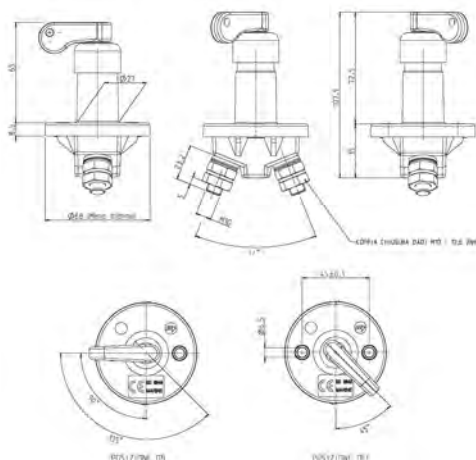

Code	Desc.
3200008098	8098

Tecnical Features	
Tensione nominale	Max 24V
Maximum continuous current	200A
Maximum short time current	1000A x 5 sec
Protection rating	IP67
Temperatura d'impiego	-40°C + 85 ° C
Contacts	In rame
Contact nuts	M10 ottone

## Battery switch 250A



- Interruttore staccabatteria con maniglia fissa. Campo di applicazione: veicoli industriali in genere e veicoli Fiat Iveco.
- Compatibile con il modello Iveco 4822229.

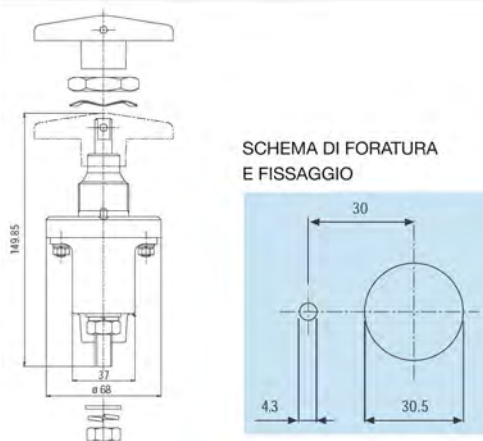

Code	Desc.
3200008050	8050

Tecnical Features	
Temperatura d'impiego	- 40°C / + 80° C
Contacts	silver-plated copper
Contact nuts	M10 Brass
Protection rating	IP 65
Maximum short time current	2500 A x 3 sec
Maximum continuous current	250 A
Tensione nominale	Max 24 V

## Battery switch 250A



- Diverter with fixed handle.
- Scope: industrial vehicles in general.
- Mounted 1st plant on Iveco Stralis.

Code	Desc.
3200008060	8060

Tecnical Features	
Maximum short duration current auxiliary contact	5 A
Maximum continuous current auxiliary contact	1 A
Contact nuts	M10 Brass
Contacts	Silver-plated copper
Temperatura d'impiego	- 40°C / + 80° C
Maximum short time current	2500 A x 3 sec
Protection rating	IP 65
Tensione nominale	Max 24 V
Maximum continuous current	250 A

Spare Parts		
Accessories	Code	Description
Kit 2 caps for connecting pins	3200008090	8090
Cap for auxiliary contact switch	3200008100	8100

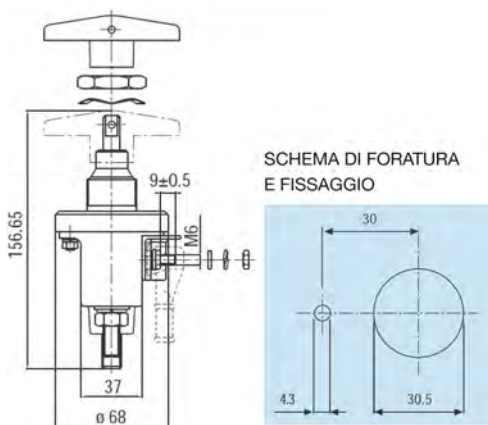

## Battery switch 250A



- Con chiave estraibile

Code	Desc.
3200008062	8062

Tecnical Features	
Tensione nominale	Max 24V
Maximum continuous current	250A
Maximum short time current	2500A x 5 sec
Protection rating	IP65
Temperatura d'impiego	-40°C +80 ° C
Contacts	In rame argentato
Contact nuts	M10 in ottone

Spare Parts	
Code	Description
3200008063	Chiave estraibile

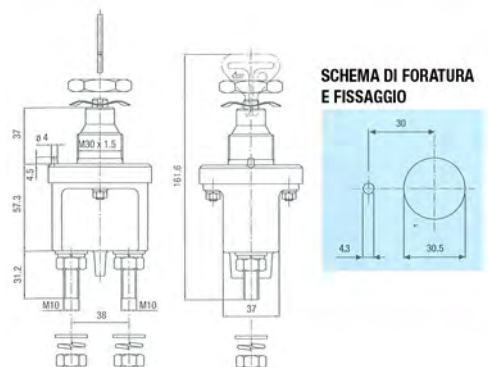

## Battery switch 300A



- Con manopola rotante
- Manopola rotante a 2 posizioni on-off
- Indicato anche per il settore nautico

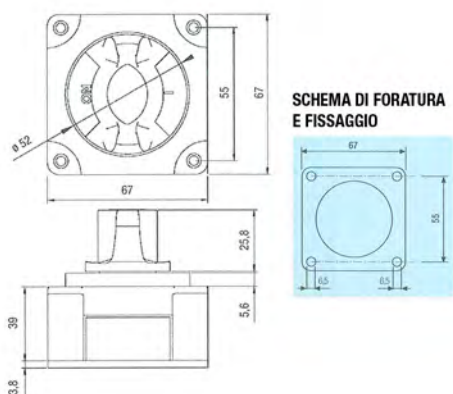

Code	Desc.
3200008065	8065

Tecnical Features	
Tensione nominale	Max 24V
Maximum continuous current	300A
Maximum short time current	1000A x 5 sec
Protection rating	IP54
Temperatura d'impiego	-40°C +80 ° C
Contacts	In rame argentato
Contact nuts	in ottone

## Battery switch 300A



- Con maniglia fissa
- Indicato per macchine movimento terra
- Oem IVECO 4758238

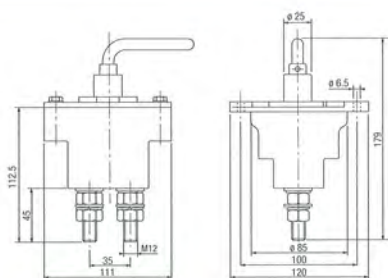

Code	Desc.
3200008095	8095

Tecnical Features	
Contact nuts	M12 in ottone
Contacts	In rame argentato
Temperatura d'impiego	-40°C +80 ° C
Protection rating	IP65
Maximum continuous current	300A
Maximum short time current	2500A x 3 sec
Tensione nominale	Max 24V

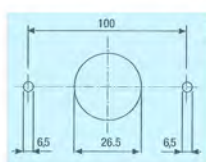

## Battery switch 350A



- Interruttore staccabatteria con leva estraibile.
- Campo di applicazione: veicoli industriali in genere, autobus, macchine movimento terra, mezzi agricoli, carrelli elevatori, sponde montacarichi ed altri motori elettrici ausiliari.
- La notevole portata (350A), rende lo staccabatteria Meccanocar tra i più potenti attualmente in commercio.

Code	Desc.
3200008070	8070

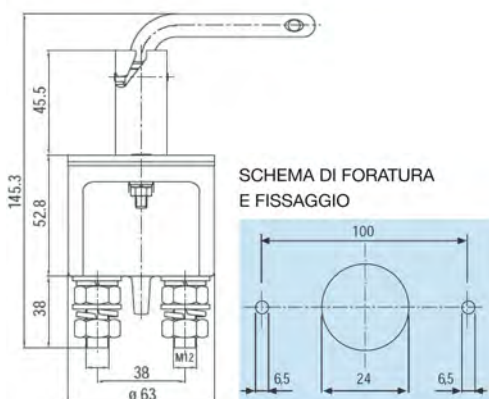

Technical Features	
Contacts	Rame argentato
Contact nuts	M12 Acciaio zincato
Temperatura d'impiego	- 40°C / + 80° C
Protection rating	IP 65
Tensione nominale	Max 24 V
Maximum short time current	2500 A x 3 sec
Maximum continuous current	350 A

Spare Parts		
Accessories	Code	Description
Handle spare	3200008080	8080
Kit 2 caps for connecting pins	3200008090	8090

## Kit staccabatteria elettronico a norme ADR



- Per Impianti a 12V
- Per batterie sino a 250A
- Intervento automatico in caso di corto circuito con distacco del polo positivo

Code	Desc.
3200008212	Kit ADR12V

Technical Features	
Maximum continuous current	250A
Maximum short time current	2500A x 3 sec.
Tensione nominale	12V
Protection rating	IP65/XP7
Contacts	rame argentato
Contact nuts	ottone
Temperatura d'impiego	-40° +85°



## Kit staccabatteria elettronico a norme ADR



- Per Impianti a 24V
- Per batterie sino a 250A
- Intervento automatico in caso di corto circuito con distacco del polo positivo

Code	Desc.
3200008224	Kit ADR 24V

Tecnical Features	
Maximum continuous current	250A
Maximum short time current	2500A x 3 sec.
Tensione nominale	24V
Protection rating	IP65/XP7
Temperatura d'impiego	-40° + 85°
Contact nuts	ottone
Contacts	rame argentato

## Connettori bipolari per muletti



- Kit connettori maschio+femmina 160A
- Fissaggio cavo a serrafilo
- Cavo da 35mm<sup>2</sup>
- Ottima resistenza all'umidità, agli acidi e ai raggi UV..
- Temperatura di esercizio da -20° a + 90°
- **Tensione max di utilizzo 48V**

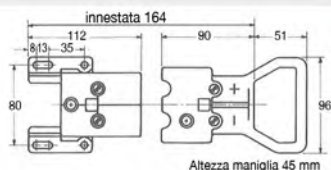

Code	Desc.
3200010100	KIT CONNETTORI M+F 35mm <sup>2</sup>

## Connettori bipolari per muletti



- Kit connettori maschio+femmina 250A
- Fissaggio cavo a serrafilo
- Cavo da 50mm<sup>2</sup>
- Ottima resistenza all'umidità, agli acidi e ai raggi UV..
- Temperatura di esercizio da -20° a + 90°
- **Tensione max di utilizzo 48V**

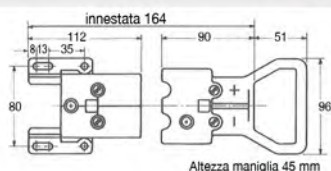

Code	Desc.
3200010150	KIT CONNETTORI M+F 50mm <sup>2</sup>

## Treccia di massa strisciante

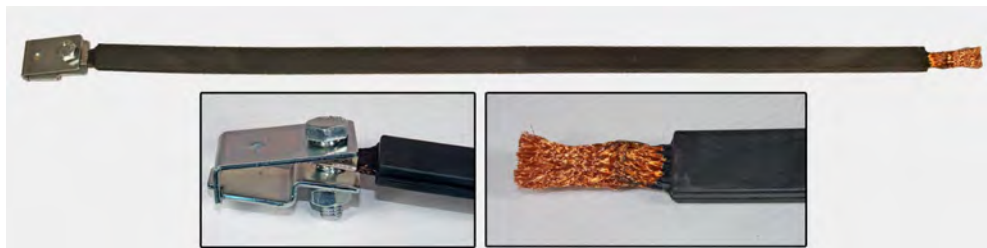

- Indicata per lo scarico a terra nei veicoli industriali
- Lunghezza 88cm
- Sezione del cavo in rame :20 mm<sup>2</sup>
- Con minuteria x il fissaggio a telaio
- **Con certificazione di conformità allegata**

Code	Desc.
4460042190	Treccia di massa

## Cicalino



- Campo di applicazione da 5 a 32V
- Protetto contro l'inversione di polarità
- Temperatura di esercizio da -30° a +80°
- Intensità sonora 85+-5 Db
- Corrente assorbita 3-20ma
- Grado di protezione IP65

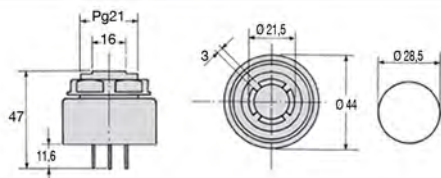

Code	Desc.
4280000920	92 CICALINO 5-32V

## Buzzer intermittent sound multitension



- Protected against reverse polarity.
- IP66 protection.
- Operating temperature -20 ° C to 85 ° C.
- Operating voltage 3-100V.
- Loudness output 95 db.

Code	Desc.
4280000900	90

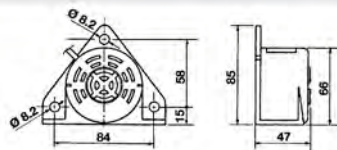

## Buzzer intermittent sound



- Protected against reverse polarity.
- Degree of protection IP 32.
- Loudness output 75 db.
- OP frequency. 2000Hz 1Hz.
- Operating voltage 12-24V.

Code	Desc.
4280000910	91

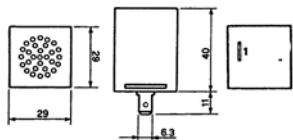

## Buzzer 102 dB (A) for reversing



- Buzzer electronic high power for the reporting of reversing operations, usable on any type of medium with the electric circuit 12 or 24 Volts.
- Suitable for use on commercial vehicles, trucks, buses, construction equipment, means for handling goods, agricultural vehicles, etc..
- Easy assembly, instructions attached to the electrical connections and the possibility of switching off during night. Sound pressure of 102 dB (A), compliant with SAE J994.

Code	Desc.
4280000901	90/1

## Buzzer 112 dB (A) to reverse

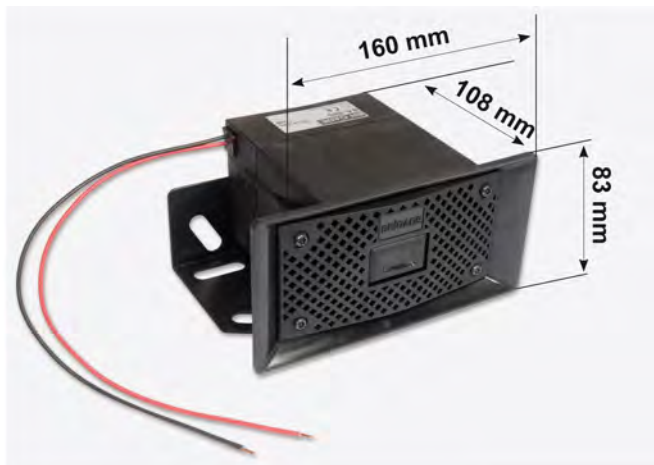

- Buzzer electronic high power for the reporting of reversing operations, usable on any type of medium with the electric circuit 12 or 24 Volts.
- The sound pressure of 112 dB (A) makes it particularly suitable for use in a noisy place, and where people wear hearing protection.
- Suitable for use on commercial vehicles, trucks, buses, construction equipment, means for handling goods, agricultural vehicles, etc..
- Easy assembly. Sound pressure of 112 dB (A), compliant with SAE J994.

Code	Desc.
4280000902	90/2





## Tire service

Balancing weights . . . . .	pag. 1626	Tools for tire specialists . . . . .	pag. 1636
Tubeless valves . . . . .	pag. 1632	TPMS System . . . . .	pag. 1655



## Sticky bars and balances lead to alloy wheels



- Directions for the use of counterweights in lead. These counterweights NOT comply with the European directive ELV N ° 2000/53 / EC and therefore should not be used in respect of this EU Directive, vehicles of class M1 and N1.
- The thickness includes the adhesive film.
- Adhesive film of high quality.
- 60 grams total, 4 pieces of 5 gr. + 4 pieces of 10 gr.
- Lead natural color.
- Easily formed and separated.

Code	Desc gr.	Grams	Thickness mm	Width mm	Utilization
3670000300	60 SLIM	4x5 + 4x10	3,8	18	Suitable for motorbikes and scooters



- Directions for the use of counterweights in lead. These counterweights NOT comply with the European directive ELV N ° 2000/53 / EC and therefore should not be used in respect of this EU Directive, vehicles of class M1 and N1.
- The thickness includes the adhesive film
- Adhesive film of high quality SPEEDLINER to detach without leaving sticky residue
- 40 grams total, 8 pieces to 5 grams.
- Optimal dimensions for wheels with narrow channel
- Easily formed and separable.

Code	Desc gr.	Grams	Thickness mm	Width mm	Color	Utilization
3670000390	40 SLIM-P	8x5 gr.	4,8	10	lead natural	Suitable for motorcycles
3670000395	40 SLIM-N	8x5 gr.	4,8	10	Black	Suitable for motorcycles



- Directions for the use of counterweights in lead. These counterweights NOT comply with the European directive ELV N ° 2000/53 / EC and therefore should not be used in respect of this EU Directive, vehicles of class M1 and N1.
- The thickness includes the adhesive film.
- Adhesive film of high quality.
- 60 grams total, 4 pieces of 5 gr. + 4 pieces of 10 gr.
- Lead natural color.
- Easily formed and separated.

Code	Desc gr.	Grams	Thickness mm	Width mm	Utilization
3670000100	60 standard	4x5 + 4x10	5	15	Moto-Caravan-commercial vehicles



- Directions for the use of counterweights in lead. These counterweights NOT comply with the European directive ELV N ° 2000/53 / EC and therefore should not be used in respect of this EU Directive, vehicles of class M1 and N1.
- The thickness includes the adhesive film.
- Adhesive film of high quality.
- 100 grams total, 5 pieces from 20 gr.
- Lead natural color.
- Easily formed and separated.

Code	Desc gr.	Grams	Thickness mm	Width mm	Utilization
3670000700	100	5x20 gr.	7	15	Truck



- Directions for the use of counterweights in lead. These counterweights NOT comply with the European directive ELV N ° 2000/53 / EC and therefore should not be used in respect of this EU Directive, vehicles of class M1 and N1.
- The thickness includes the adhesive film.
- Adhesive film of high quality.
- Silver, due to the powder coating epoxy.
- Easily formed.
- Our product is mounted in the first plant by Renault-Volvo-Mercedes-Benz Evobus.

Code	Desc gr.	Grams	Utilization
367PL00050	50	50 gr.	Truck
367PL00100	75	75 gr.	Truck
367PL00200	100	100 gr.	Truck
367PL00300	150	150 gr.	Truck

## Counterweights spring in lead for truck for tubeless tires from 22.5 in and above



- Clips particularly adaptable for steel wheels with thin edge.
- Silver, due to the powder coating epoxy.
- Our product is mounted in the first plant by Mercedes Benz.

Code	Desc gr.	Grams	Utilization
364TR00050	50	50 gr.	Truck
364TR00100	100	100 gr.	Truck
364TR00200	150	150 gr.	Truck
364TR00300	200	200 gr.	Truck
364TR00400	250	250 gr.	Truck
364TR00500	300	300 gr.	Truck

## Pesi per autocarro tubeless



- Contrappesi in piombo con molla fissa in acciaio.
- Per autocarri con cerchi tubeless.

Code	Desc gr.
364CA00100	50
364CA00200	75
364CA00300	100
364CA00400	150
364CA00500	200
364CA00600	250
364CA00700	300

## Sticky bars and balances iron for alloy wheels



- The thickness includes the adhesive film.
- Adhesive film of high quality.
- 60 grams total.
- Optimal dimensions for wheels with narrow channel.
- Easily formed and separated.

Code	Desc.	Grams	Thickness mm	Width mm	Color	Utilization
3670000600	60 SLIM-Z	12x5 gr.	3,8	19	Galvanized	Auto -Caravan - V.I.
3670000604	60 SLIM-N	12x5 gr.	3,8	19	Black	Auto -Caravan - V.I.
3670000602	60 SLIM-R	12x5 gr.	3,8	19	Silver powder	Auto -Caravan - V.I.
3670000606	60F SLIM-R	4x5 gr+4x10 gr	3,8	19	Silver powder	Auto -Caravan - V.I.
3670000610	61F SLIM-Z	4x5 gr+4x10 gr	3,8	19	Galvanized	Auto -Caravan - V.I.

## Adhesive weights in roller iron for alloy wheels

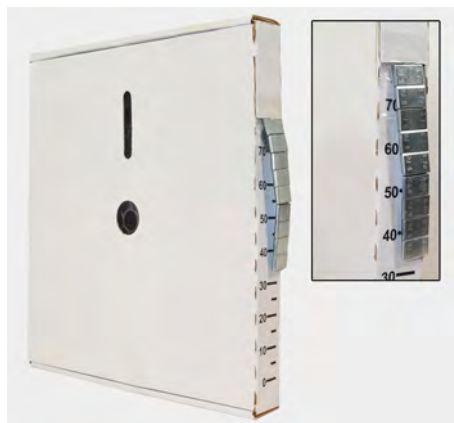

- The thickness includes the adhesive film.
- Adhesive film of high quality.
- 6 kg. Compounds of 1200 from 5 gr.
- Color galvanized.
- Easily formed and separated.

Code	Desc.	Grams	Thickness mm	Width mm	Utilization
3670000800	397 RU	1200x5 gr.	3,8	19	Car-bike

## Roller door for 397RU



- Suitable for roller weights from 5 kg.
- Multifunctional, either on the wall or on the workbench.
- Not suitable for 6 kg rollers

Code	Desc.
3670000810	2800

## Universal balancing spring fixed in zinc for steel wheels



Code	Desc gr.	Grams	Utilization
364EC00050	5	5 gr.	Auto-Commercial Vehicles
364EC00100	10	10 gr.	Auto-Commercial Vehicles
364EC00150	15	15 gr.	Auto-Commercial Vehicles
364EC00200	20	20 gr.	Auto-Commercial Vehicles
364EC00250	25	25 gr.	Auto-Commercial Vehicles
364EC00300	30	30 gr.	Auto-Commercial Vehicles
364EC00350	35	35 gr.	Auto-Commercial Vehicles
364EC00400	40	40 gr.	Auto-Commercial Vehicles
364EC00450	45	45 gr.	Auto-Commercial Vehicles
364EC00500	50	50 gr.	Auto-Commercial Vehicles
364EC00550	55	55 gr.	Auto-Commercial Vehicles
364EC00600	60	60 gr.	Auto-Commercial Vehicles

- Zinc coated with epoxy powder in silver.
- The special clip attachment of the counterweight enables universal use for almost all circles in iron and steel also of French cars and light trucks.

## Universal balancing spring fixed in zinc for alloy wheels



Code	Desc gr.	Grams	Utilization
366EC00050	5	5 gr.	Auto-Commercial Vehicles
366EC00100	10	10 gr.	Auto-Commercial Vehicles
366EC00150	15	15 gr.	Auto-Commercial Vehicles
366EC00200	20	20 gr.	Auto-Commercial Vehicles
366EC00250	25	25 gr.	Auto-Commercial Vehicles
366EC00300	30	30 gr.	Auto-Commercial Vehicles
366EC00350	35	35 gr.	Auto-Commercial Vehicles
366EC00400	40	40 gr.	Auto-Commercial Vehicles
366EC00450	45	45 gr.	Auto-Commercial Vehicles
366EC00500	50	50 gr.	Auto-Commercial Vehicles
366EC00550	55	55 gr.	Auto-Commercial Vehicles
366EC00600	60	60 gr.	Auto-Commercial Vehicles

- Zinc coated with epoxy powder in silver.
- The special clip attachment of the counterweight enables universal use for almost all alloys and aluminum.

## Universal balancing spring fixed in zinc for steel wheels type French



- Zinc coated with epoxy powder in silver.
- The special clip attachment of the counterweight enables universal use for steel wheels French cars.

Code	Desc.	Grams	Utilization
365EC00050	5	5 gr.	Auto-Commercial Vehicles
365EC00100	10	10 gr.	Auto-Commercial Vehicles
365EC00150	15	15 gr.	Auto-Commercial Vehicles
365EC00200	20	20 gr.	Auto-Commercial Vehicles
365EC00250	25	25 gr.	Auto-Commercial Vehicles
365EC00300	30	30 gr.	Auto-Commercial Vehicles
365EC00350	35	35 gr.	Auto-Commercial Vehicles
365EC00400	40	40 gr.	Auto-Commercial Vehicles
365EC00450	45	45 gr.	Auto-Commercial Vehicles
365EC00500	50	50 gr.	Auto-Commercial Vehicles
365EC00550	55	55 gr.	Auto-Commercial Vehicles
365EC00600	60	60 gr.	Auto-Commercial Vehicles

## Universal balancing adhesive zinc for alloy wheels



- Zinc coated with epoxy powder in silver.
- The special invoice of construction grooved easy to service of all types of curvatures of the circle.
- Mounted in first plant from Porsche-VW-Audi-Volvo-Ford-Opel.
- Thickness of 3.8 mm tape.
- Width 19 mm.

Code	Desc.	Grams	Number Gorges <i>horizontal</i>	Utilization
367ZI00050	5	5 gr.	0	Auto-Moto-commercial vehicles
367ZI00100	10	10 gr.	1	Auto-Moto-commercial vehicles
367ZI00150	15	15 gr.	1	Auto-Moto-commercial vehicles
367ZI00200	20	20 gr.	1	Auto-Moto-commercial vehicles
367ZI00250	25	25 gr.	1	Auto-Moto-commercial vehicles
367ZI00300	30	30 gr.	2	Auto-Moto-commercial vehicles
367ZI00350	35	35 gr.	2	Auto-Moto-commercial vehicles
367ZI00400	40	40 gr.	3	Auto-Moto-commercial vehicles
367ZI00450	45	45 gr.	3	Auto-Moto-commercial vehicles
367ZI00500	50	50 gr.	3	Auto-Moto-commercial vehicles
367ZI00550	55	55 gr.	4	Auto-Moto-commercial vehicles
367ZI00600	60	60 gr.	4	Auto-Moto-commercial vehicles

## Powder balancing Meccanocar 505



- By placing a bag inside the tire, due to centrifugal force, the powder is distributed evenly on the walls, and where there is an imbalance, is deposited and goes to compensate. Compensation is perennial, dust adapts to changes of temperature, road conditions and driving style.
- DUST 505 is MECCANOCAR DIFFERENT, because it is a source of study and research with Hofmann Technology. In fact it is made from red grains larger, which are concentrated in the center of the tire and compensate the static unbalance and granules smaller blue which move outward and reduce the dynamic imbalance. Composition of the granules: is a natural mineral material to special coating.
- Each envelope must be paid entirely inside the tire, and is contained within a dispenser
- Cap and internal mechanism integrated in the envelope and easy to pull out for easy use.
- Installation instructions on the envelope inside with accessories to be mounted to pour the contents through the valve. Each bag contains the application table.
- Product also compatible with TPMS.
- There is no need to balance.
- Ecological product for disposal.
- Sector-specific truck and construction equipment.

Code	Desc.	Content gr.
3970012500	120XS	120
3970012510	180S	180
3970012520	230M	230
3970012530	290L	290
3970012540	350XL	350



## Application table

A	B	A	B	TAGLIA	A	B	TAGLIA	A	B	TAGLIA
315/70R	22,5	31/10,5	15	XS	275/65	18	S	385/55	22,5	XL
		265/75	16	XS	265/70	18	XS	285/60	22,5	L
		235/85	16	XS	275/70	18	S	295/60	22,5	L
		285/70	17	S	385/55	19,5	XL	305/60	22,5	L
		215/70	17,5	XS	255/60	19,5	S	315/60	22,5	L
		265/70	17,5	S	385/65	19,5	XL	500/60	22,5	XL+XL
		215/75	17,5	XS	225/70	19,5	M	385/65	22,5	XL+XS
		245/75	17,5	S	245/70	19,5	S	425/65	22,5	XL+S
		315/80	17,5	L	265/70	19,5	S	445/65	22,5	XL+S
		8,5	17,5	XS	275/70	19,5	M	255/70	22,5	M
		10	17,5	M	285/70	19,5	M	265/70	22,5	M
		225/75	16	XS	295/70	19,5	M	275/70	22,5	L
		285/75	16	S	305/70	19,5	L	305/70	22,5	L
		245/70	17	XS	315/70	19,5	L	315/70	22,5	L
		245/75	17	XS	275/65	20	S	295/75	22,5	XL
		235/70	17,5	XS	405/70	20	XL+XS	315/75	22,5	XL
		315/70	17,5	M	375/75	20	XL+XS	345/75	22,5	XL
		225/75	17,5	XS	425/75	20	XL+S	350/75	22,5	L+XS
		205/80	17,5	S	275/80	20	L	445/75	22,5	L+L
		225/90	17,5	S	335/80	20	XL	255/80	22,5	M
		9	17,5	S	475/80	20	XL+XL	275/80	22,5	L
		245/75	16	XS	365/85	20	XL+XS	295/80	22,5	XL
		215/85	16	XS	395/85	20	XL+S	315/80	22,5	XL
		265/70	17	XS	10,5	20	L	11	22,5	L
		235/80	17	XS	12,5	20	XL	12	22,5	XL
		245/70	17,5	XS	14,5	20	XL+XS	13	22,5	XL
		205/75	17,5	XS	24	20,5	L	405/70	24	L+L
		235/75	17,5	S	495/45	22,5	XL+S	445/70	24	XL+L
		225/80	17,5	S	355/50	22,5	XL	455/70	24	XL+XL
		8	17,5	XS	435/50	22,5	XL+XS	495/70	24	XL+XL
		9,5	17,5	S	445/50	22,5	XL+XS	285/75	24,5	XL
					455/50	22,5	XL+XS	11	24,5	XL
					275/65	18	S	385/55	22,5	XL

## Tubeless valves rubber



- General applications in passenger cars and vans.

Code	Desc.	Length mm	Base (mm)	For hole mm
3970002750	27/1 - TR 412	33	19,5	11,3
3970002800	28 - TR 413	43	19,5	11,3
3970002900	29 - TR 414	49	19,5	11,3
3970000100	1 - TR 414 L	56,5	19,5	11,3
3970000200	2 - TR 415	43	23,5	15,7
3970003000	30 - TR 418	61	19,5	11,3
3970003010	30/1 - TR 423	74	19,5	11,3
3970003020	30/2 - TR 425	60	23,5	15,7

## Tubeless valves rubber chrome



- Mounted on alloy wheels and rims where the valve remains in full view.

Code	Desc.	Length mm	Base (mm)	For hole mm
3970000350	3/1 - TR 412 C	33	19,5	11,3
3970000400	4 - TR 413 C	42,5	19,5	11,3
3970000500	5 - TR 414 C	49	19,5	11,3
3970000700	7 - TR 418 C	61,5	19,5	11,3

## Valves HP-high pressure for commercial vehicles



- HP = high pressure valves.
- For commercial vehicles, caravans, trailers, SUVs and vans.
- Pressure up to 6.9 bar.

Code	Desc.	Length mm	For hole mm
3970016140	TR600HP	44	11,3
3970016150	TR602HP	63	11,3

## Tubeless valves for motorcycles



- Aluminum valve 80 ° bent.

Code	Desc.	Length mm	For hole mm
3970000800	8	25	8,3
3970000810	8/11	25	11,3



- Rubber valve.

Code	Desc.	Length mm	For hole mm
3970000900	9 - TR 438	40,5	8,8

### Valve for scooters



- Valve bent 90 °.

Code	Desc.	Length mm	Lean angle	For hole mm
3970001000	10	30	90°	8,3
3970001010	90/30	30	90°	11,3

### Tubeless valves truck



- Valves 1 curve.

Code	Desc.	A mm	B mm	a
3970007300	73	25	40	27°
3970007400	74	25	50	27°
3970007500	75	25	60	27°
3970007600	76	25	85	27°
3970007700	77	30	95	27°
3970007800	78	50	25	27°

### Tubeless valves tractor

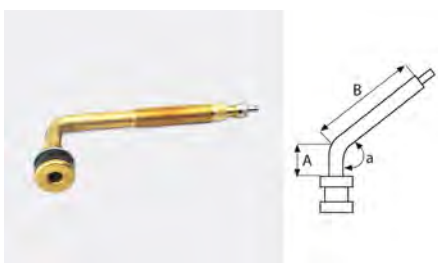

- Valves 1 curve.

Code	Desc.	A mm	B mm	a
3970009300	93 - TR 621A	39	54,5	115°
3970009400	94 - TR 622A	44,5	94,5	90°
3970009500	95 - TR 623A	39	36,5	115°

### Tubeless valves Civil Engineers

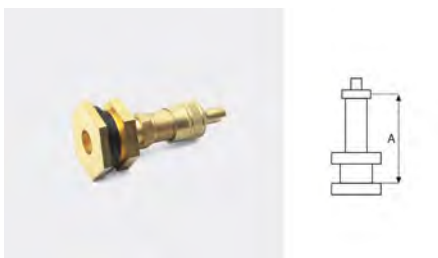

- Straight valves.

Code	Desc.	A mm
3970009800	98 - TRJ 670	41

## Reducing valve for Civil Engineers



- Essential for inflating valve Civil Engineers with a common inflator, ie head for autocamion.

Code	Desc.
3970009900	99

## Extensions flexible rubber



- For inflating the wheels.

Code	Desc.	Length mm
3970010000	100	140
3970010100	101	180
3970010200	102	210

## Extensions in plastic



- Ideal for use with trip valves rubber for vans and commercial vehicles.
- With short design 15 mm.

Code	Desc.	Length mm
3970010300	103	85
3970010400	104	115
3970010500	105	140
3970010600	106	160

## Fixing plate single



- Plate to be applied on the wheel rim with slot for housing extension.

Code	Desc.
3970010700	107

## Fixing plate double



- Plate to be applied on the rim wheel with slots for housing extensions.

Code	Desc.
3970010800	108

## Brass extension at 45 °



- To be mounted on valves facing the wheel rim so with difficult access to the thesis of the inflator.

Code	Desc.
3970010900	109

## Universal caps for steel valves and nylon



- Material nylon or steel.
- Available colors nylon: red, green, blue.
- caps chrome for our valves cod. 3970000350 ..... .3970000700.

Code	Desc.	Characteristics
3970001200	12	STEEL CAPS
3970001210	12/1	NYLON BLUE CAPS
3970001220	12/2	NYLON GREEN CAPS
3970001230	12/3	NYLON RED CAPS
3970001240	12/4	CHROME CAPS
3970001300	13	NYLON BLACK CAPS



## Striper for tires



- Tool suitable for regrooving of tires for industrial vehicles and construction equipment.
- The intervention of regrooving is to reproduce the design of the grooves, by removing the rubber pad below this' can extend the life of the tire.
- Article suitable for tire, truck drivers, construction, etc.
- The tire suitable for regrooving must state on the side marked "regloovable" or the symbol "u".
- The 11 positions for heating the engraving allow a wide range of applications making the article extremely professional.
- The blades are not included in the package.

Code	Desc.
3970001310	14/2RIG

Technical Features	
Power supply cable length (cm)	220
Length cable support, bladesport (cm)	150
Total weight	6320
Weight blade holder support (gr)	500
Progressive regulation	0-11
Supply voltage (v)	220
Max power consumption (W)	400

Spare Parts		
Article	Code	Description
HEAD DOOR BLADES COMPLETE V. MODEL	3970001340	14 TPL
COUPLE HEADS SPARE V. MODEL	3970001350	14 CP
COUPLES SCREW HEADS FOR SPARE V. MODEL	3970001360	14 CV
HEAD DOOR HANDLE BLADES AND RIG 14/2	3970001338	14 TN

## Blades for striper tires



- Lame round and square provided in box no. 2 pcs.

Code	Desc.	Shaped blade	Width cut mm
3970001315	14 LR	ROUND	2 MM
3970001316	14 LR	ROUND	3 MM
3970001317	14 LR	ROUND	5 MM
3970001318	14 LR	ROUND	7 MM
3970001319	14 LR	ROUND	9 MM
3970001330	14 LQ	SQUARE	2 MM
3970001331	14 LQ	SQUARE	4 MM
3970001332	14 LQ	SQUARE	6 MM
3970001333	14 LQ	SQUARE	8 MM
3970001334	14 LQ	SQUARE	10 MM

## Pliers for counterweights



- Ideal for installing and removing the weights from the rim

Code	Desc.
4430027300	339

## Tool mounting weight



- Tool for fitting counterweights.
- Particularly suitable for mounting counterweights German cars and Chrysler.

Code	Description
3970001395	14 ME-TOOL ASSEMBLY COUNTERWEIGHTS

## Tool bars remove adhesive



- Completely Teflon to avoid damaging the rim.
- Ideal for removing adhesive from tool bars balancing alloy wheels.

Code	Description
3970001390	14RIM-REMOVE TOOL BARS

## Tool fitting valves



- Ideal for use with trip valves rubber for vans and commercial vehicles.
- With short design 15 mm.

Code	Description	Article
3970001100	11	All metal
3970001110	11 / Plastic	Plastic and metal tip + unscrews internal valve

## Tool unscrews interior plastic



- Specific tool to remove the mechanism located inside the valve.
- One side valve motorcycle-car-truck, one hand for civil engineering.

Code	Desc.
3970003300	33

## Plasters for marking (steatite)



- Also write on wet tires.

Code	Desc.	Color	Ø mm
3970002400	24	WHITE	14
3970002500	25	YELLOW	14

## Spherical pencil rasp

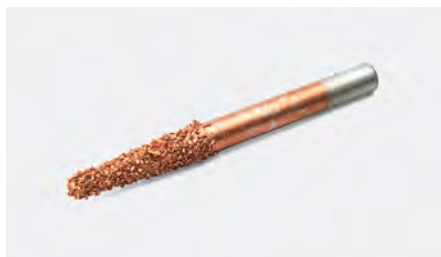

- For use with electric or pneumatic die grinder.
- To clean the inside of the tire before the repair.

Code	Desc.	Ø stem (mm)	Length mm
3970011000	110	6	65

## Mola curved profile



- To clean the inside of the tire before the repair.
- For use with adapter n / s art. cod. 397 00 11200-112.

Code	Desc.	Dimensions mm	Tthread	Grain
3970011100	111	ø 50x25	3/8"x24 UNF	36

## Adapter for grinder



- Specific wheel n / s art. cod. 397 00 11100-111.
- Adapter to be mounted on pneumatic or electrical grinders straight.

Code	Desc.	Length mm	Ø stem (mm)	Tthread
3970011200	112	47	6	3/8"x24 UNF

## Cutters carbide (or carbide) for tire repair



- For internal repairs of tires, are used to clean and prepare the positioning of mushrooms repair.
- Cutters are sintered metal carbides (tungsten carbide).
- They must be used with a straight grinder 22.000giri / min. NS CODE 4180006700.

Code	Desc.	Diameter mm
3970012450	3	D.3
3970012460	6	D.6
3970012470	9	D.9

## Measuring tread

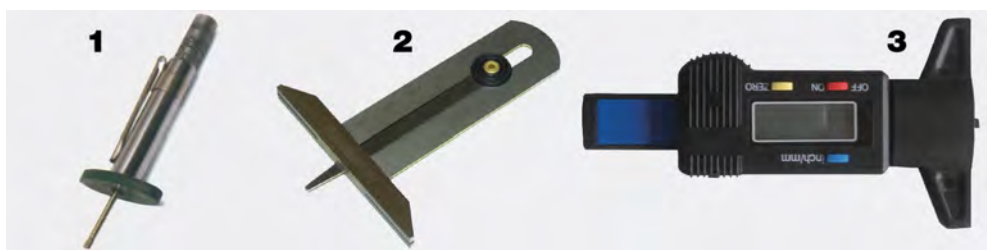

Code	Desc.	Characteristics
3970002350	23/1	Entirely metal-spring for securing the pockets
3970002360	23/2	All metal-delivered in a box
3970002370	23/3	Digital meter tread

## Roller for repairs



- Measuring: D.40 x 4 mm
- Ideal for adhering patched tire.

Code	Description
3970012480	Roller

## Lever tires



- Tire lever in chrome vanadium steel.
- Zinc-chrome execution.

Code	Desc.	L mm	h mm
4430039910	444	300	22,0
4430039920	444	400	24,5
4430039930	444	500	26,0
4430039940	444	600	28,0

## Bushings for alloy wheels



- Long sleeves hexagonal version for alloy wheels.
- The special outer coating made of plastic you can not scratch the rim while the internal protection protects against scratches nuts or shiny chrome.
- Particularly suitable for tire specialists, mechanics, body shops and repair shops generally.

Code	Desc.
4430049910	974 - 17
4430049920	974 - 19
4430049930	974 - 21

## Series compasses for wheels



- Kit version hexagonal long sleeves for alloy wheels.
- The special outer coating made of plastic you can not scratch the rim while the internal protection protects against scratches nuts or shiny chrome.
- Particularly suitable for tire specialists, mechanics, body shops and repair shops generally.

Code	Desc.	Content	Application
4430049900	974S	3 BUSHES ATT. 1/2 "	UTILITY = M17 M19 M21 = = BERLINE VETT. JAPANESE AND OFF-ROAD

## Impact torsion bars



- Torsion bars for tightening wheel nuts.
- Used only with impact wrench.
- Pre-calibrated for different tightening torques.
- With square male-female 1/2 ".
- Full assortment to cover all needs fixing.

**ATTENZIONE**

TABELLA APPLICATIVA INDICATIVA	
<b>Cerchi in ferro</b>	BARRA ROSSA
<b>Cerchi in lega leggera</b>	BARRA ROSA
<b>Cerchi Mercedes e furgoni</b>	BARRA BIANCA

LA COPPIA PUO' ESSERE INFLUENZATA DAL TIPO E CONDIZIONI DI AVVITATORE, BULLONE O DADO E ARIA DI ALIMENTAZIONE. SI CONSIGLIA PERTANTO DI EFFETTUARE UN CONTROLLO CON CHIAVE DINAMOMETRICA

Code	Desc.	Color	Torque Nm	Female	Male	Ø mm	L mm	Hooking type
4430049450	934 - 80	Rosso	÷ 75	1/2"	1/2"	25,5	152	Red
4430049455	934 - 120	Pink	÷ 120	1/2"	1/2"	25,5	152	SPHERE
4430049460	934 - 170	White	÷ 160	1/2"	1/2"	25,5	152	SFERA

## Compasses bolt damaged 1/2 "



- Socket set with coned coil.
- Suitable for car workshops, tire repairers and bodywork.
- Allow it to loosen and remove easily, safe and timely nuts and bolts locked, with threads or damaged heads and / or rounded.
- Particularly useful to remove bolts "theft" mounted on the wheels of most cars on the road.
- The conical helical profile allows the compass to firmly engage the screw or bolt in order to create a sturdy grip.
- The series carries a lower expenditure of time and energy in the process of unlocking and less risk of damage to the bolt.
- Content box: 4 sleeves with 1/2 "metal rod to eject the 80mm bolt compasses.

Code	Desc.	Content
4770005320	620	Kit 4 compasses conical coil: 17-19-21-23 mm
4770005321	620/17	17 mm
4770005322	620/19	19 mm
4770005323	620/21	21 mm
4770005324	620/23	23 mm



## Guns inflates tires Professional EEC



- Available with pressure gauge  $\varnothing$  63 and 80 mm.
- Pressure 0 ÷ 10 bar.
- Tube length 100 cm.
- Bayonet.
- \* For n / s art. cod. 345 00 345 00 01530 to 1159 and from 01,576 to 1,167.

Code	Desc.	Characteristics
3450001530	1159	GUN WITH MAN. $\varnothing$ 63 EEC
345RC03770	377	SPARE MANOMETER $\varnothing$ 63 EEC
345RC03760	376	PIPE REPLACEMENT COMPLETE *
3450001576	1167	GUN WITH MAN. $\varnothing$ 80 EEC
345RC04000	400	SPARE MANOMETER $\varnothing$ 80 EEC

## Inflating gun eurodainu



- Built under license Michelin.
- Manometer  $\varnothing$  90 mm.
- Maximum pressure 11 bar.
- Tube length 150 cm.
- Air connection 1/4 "female gas.

Code	Desc.	Characteristics
3450001577	1168	GUN EURODAINU SCALE ONLY BAR
345RC03180	318	PIPE REPLACEMENT FEMALE THREAD
345RC03190	319	PIPE REPLACEMENT MALE THREAD

## Eurodainu inflating gun with double scale bar-psi



- Built under license Michelin.
- Manometer  $\varnothing$  90 mm.
- Pressure 0 ÷ 12 bar.
- Tube length 150 cm.
- Air connection 1/4 "female gas.

Code	Desc.	Characteristics
3450001578	1168-Bar-Psi	EURODAINU GUN WITH DOUBLE SCALE BAR AND PSI
345RC03180	318	PIPE REPLACEMENT FEMALE THREAD
345RC03190	319	PIPE REPLACEMENT OLD THREAD MALE MODEL

## Head for tire inflators



- Replacement head for n / s art. cod .: 345 00 01530-1159; 345 00 01576 to 1167; 345 00 01577-1168; 345 00 01577- 1168.

Code	Desc.
345RC03840	384

## Inflation nozzle for wheels



- Ideal where space is a problem for inflation.
- Apply directly to the head of the inflator without removing anything.

Code	Desc.	L. tot.
345RC03841	384/1	cm 33

## Precision manometer "Quicker"



- Precision pressure gauge for monitoring the tire pressure.
- It ensures total reliability 'of reading done.
- Particularly appreciated by the preparatory team ran two four wheels.

Code	Desc.
4770001250	125

## Manometer feedback



- Only for tire pressure control.
- Manometer  $\varnothing$  63 mm.
- Pressure 0-12 bar.
- Tube length 40 cm.

Code	Desc.
3450001520	1158

## Tire inflator



- Portable tire inflator.
- It is equipped with a coil and pressure gauge for inflation / deflation of the tire.
- Tank equipped with EC testing.

Code	Desc.	Tank capacity LT
4430045600	598	10

Spare Parts		
Article	Code	Description
GUN PARTS	4430045602	598/P
SPIRAL	4430045614	599/3
MONOMETRO DI RICAMBIO SERBATOIO	4430045603	598M

## Centers wheels cart



- Cart centering.
- Suitable for car workshops and VI, VI and auto body shops, tire shops.
- It allows to lift, carry and center in a simple way and with minimum effort the tires on the bolts of the hub.
- Especially useful for people who have to operate alone or in the presence of heavy tires and large in size.
- It is equipped with arms with rotating rollers mounted on bearings for a more 'easy search of centering.
- Provided with two rubber wheels and four in plastic, of which two parts.
- Three settings for tires 6.5 "to 22.5".
- Supplied with small parts for mounting.
- Handle length: 990 mm.
- Overall Width: 700 mm.

Code	Description	Weight Kg.
4700001720	2502 - Centering cart	11,2

Spare Parts	
Code	Description
4700001730	2502R - Ruota ant.nera
4700001740	2502RP Ruota post. bianca

## Static balancer for motorcycles



- Hand Tool to verify the correct balancing of the tires of the bikes. Painted steel structure, with bubble for perfect positioning. For workshops, tire. Supplied disassembled.
- Specifications: For wheels up to 21". With pin diameter and 12mm diameter cones max 40mm. Supplied disassembled for safety in transport. Dimensions: LCM 50xPcm20xHcm50
- N: B: Ducati 916,748,998, e996, BMW motorcycles and maxi scooters can be balanced only by using the appropriate adapters.
- Instructions: A) Remove a cone from the auction of media, insert the wheel to be balanced, put the cone and tighten the Allen screw just enough to secure the position. Always place the wheel as much as possible to the center of the shaft. Place the two cones so that the two Allen screws are opposite each other, to prevent weight imbalances.
- B) Place the rod with the wheel on the balancing machine, making sure that the rod correctly rests in the middle of the disks on which must rotate the rod.
- C) Turn the wheel in order to visually check whether the tire is fitted properly in the center. After this occurs stop the wheel in any position.
- D) Leave the wheel free to move, if the wheel is unbalanced it will slowly begin to move then going to stop the heaviest part below.
- E) At this point we have a chalk mark with the highest point of the wheel (diametrically opposite the heaviest point of the wheel).
- F) At the point found to be affixed to the leads adhesives, possibly at the center of the wheel rim. The faster the movement of the wheel towards the heaviest part, the greater the weight to be applied.
- G) To see if the weight is correct, rotate the wheel ¼ turn and check that the wheel remains firm, repeat 3 more times to do testing at the four cardinal points. After this occurs, the balancing operation is to be considered completed

Code	Desc.	Characteristics
4700005920	2626	Per cerchi fino a 21"



Codice	Desc.	Accessori
4700005921	2626 SR	Kit centraggio cerchi - Foto 1
4700005922	2626-A01	Kit adattatori ruote monobraccio - Foto 2
4700005923	2626-A02	Kit adattatori ruote BMW - Foto 3
4700005924	2626-A03	Kit con perno per ruote scooter - Foto 4 (d.10)
4700005925	2626-A04	Kit adattatori Piaggio x9 - Foto 5 (d.16)
4700005926	2626-A05	Kit adattatori ruote BMW dal 2006 - Foto 6
4700005927	2626-A00	Perno standard in dotazione con coni - Foto 7 (d.12)
4700005928	2626-ACR	Cono ricambio standard diam max40mm - Foto 8



## White paste PNEU - ideal for cars and motorcycles



- Pasta lubricant and sealant for installation of car and motorcycle tires.
- Lubricates the treated part by preventing slippage of the tire during mounting.
- It regenerates and protects the rubber in part where it needs a seal on the rim (bead).
- A plant-based, soft doughy.
- Leaves no stain on the tire (white halo).

Code	Desc.	Content Kg
4110015155	2859	4

## Black paste PNEU - ideal for cars and motorcycles



- Pasta lubricant and sealant for installation of car and motorcycle tires.
- Lubricates the treated part by preventing slippage of the tire during mounting.
- It regenerates and protects the rubber in part where it needs a seal on the rim (bead).
- A plant-based, soft doughy.
- Leaves no stain on the tire-stain.

Code	Desc.	Content Kg
4110015161	2860N	5

## Blue paste pneumatic - for low-profile tires and RUNFLAT



- Pasta lubricant and sealant for the mounting of car tires inflated runflat or, that due to the hardness of the shoulder of the tire with the normal pulp would be difficult.
- Lubricates the treated part by preventing slippage of the tire during mounting.
- It regenerates and protects the rubber in part where it needs a seal on the rim (bead).
- A plant-based, soft doughy.
- Specification for assembly machines and automatic tire fitting alloy wheels.

Code	Desc.	Content Kg
4110019990	6321	4



## Yellow pasta PNEU - ideal for TRUCK



- Pasta lubricant and sealant for mounting tires VI and earthmoving.
- Lubricates the treated part by preventing slippage of the tire during mounting.
- It regenerates and protects the rubber in part where it needs a seal on the rim (bead).
- A plant-based, soft doughy much like Michelins.
- Leaves no stain on the tire.

Code	Desc.	Content Kg
4110015160	2860	4

## Brush curved wood for pulp pneumatic



- Brush specific wood with curved bristles for applying paste on the heels of the tires.

Code	Description	D
3970012490	Brush Pneu	D. 51,8

## Tire repair kit - car



**PNEUMATICO RIUTILIZZABILE DOPO L'USO DEL KIT TRAMITE SEMPLICE LAVAGGIO INTERNO CON PANNO**

**SOSTITUISCE LA RUOTA DI SCORTA**

### 6 FACILISSIME OPERAZIONI

- 1- Prendere il kit all'interno della bauliera
- 2- Togliere la valvola
- 3- Inserire gel riparatore
- 4- Rimettere la valvola
- 5- Collegare spina compressore alla presa 12V del veicolo
- 6- Gonfiare il pneumatico con il compressore controllando la pressione ottimale con il manometro

- Necessary tool for the temporary repair of punctured tires.
- Suitable for tires tubeless.
- Usable in any condition: just insert the plug into the cigarette lighter socket of the vehicle.
- Equipped with a compressor and through which you can restore the optimal pressure of the punctured tire after entering the sealant.
- Multi-purpose compressor, ideal for: flat tires, balls, cots, bicycle wheels, etc ..
- It avoids the awkward presence of a spare wheel.
- The presence of the pressure gauge reading absolutely allows a precise inflation pressure.
- Complete with sock protects compressor.
- The liquid of the tire repair kit does not affect the internal structure of the tire. With a simple cleaning by the tire through cloth and subsequent repair, the tire and 'reusable again.

### TECHNICAL FEATURES

- Plastic body.
- Repairs up to max diameter hole: 6 mm.
- Compressor size: 14,5x16,5 cm.
- Weight: 1.55 kg.
- Max pressure: 300 Psi.
- The sealant and effective at temperatures not lower than -40° C.

Code	Desc.
3970012200	410

## Spray sealant charging



- Replacement sealant in a practical canister.
- The sealant and 'effective at temperatures not lower than - 40 ° C.

Code	Description	Content ml
3970012250	410/R	473
3970012360	Dispensing cap	-

## No stop



- Inflate and repair immediately punctured tires.
- It can be used on pneumatic air chamber that tubeless.
- It applies the tube connecting the cylinder to the tire valve after eliminating the cause of the puncture. Then press the nozzle to inflate the tire.
- Just can proceed to check tire pressure.
- It is not suitable for large lacerations.

Code	Desc.	Content ml
4110010700	2692	300
4110015480	3050	200

## Kit repair tubeless tires



- In case.

Code	Desc.	Content	Applications
3970011300	113	50 STRINGS 1 RASP 1 ATTR. A "T" WITH NEEDLE	KIT FOR CARS AND MOTORCYCLES
3970011400	114	25 STRINGS 1 RASP 1 ATTR. A "T" WITH NEEDLE	KIT FOR TRUCKS

Spare Parts				
Applications	Article	Code	Description	Photo
FOR CARS	TOOL T	3970011340	113/T	1
FOR CARS, TRUCKS AND MOTORCYCLES	RASP SPARE	3970011460	113/R	2
FOR CARS	NEEDLE SPARE	3970011350	113/1	3
FOR TRUCKS	NEEDLE SPARE	3970011450	114/1	4

## Strings self vulcanizing



**MATERIALE AUTOVULCANIZZANTE**

- Strings parts for kit Ripar. tires.

Code	Desc.	Length in inches	Applications
3970011500	115	4"	CARS-MOTO
3970011600	116	8"	TRUCKS

## Materiale autovulcanizzante.

### Istruzioni

LA STRINGA AVRÀ ASSUNTO QUESTA FORMA FACENDO IN MODO CHE QUANDO SI AUTOVULCANIZZERÀ GRAZIE AL CALORE DATO DALLA VELOCITÀ DEL VEICOLO LA RIPARAZIONE SARÀ SIA INTERNA SIA SU TUTTO LO SPESSORE DEL PNEUMATICO, IMPEDENDO ALL'ACQUA DI ENTRARE E MAGARI CREARE RUGGINE NELLE TELE METALLICHE.



**1** RIMUOVERE OGNI OGGETTO DALLA GOMMA



**2** PULIRE ED ALLARGARE IL FORO CON LA RASPETTA



**3** INSERIRE LA STRINGA NELL'ATTREZZO A "T" CON AGO



**4** SPINGERE LA STRINGA NELLA GOMMA SUPERANDO LO SPESSORE DEL PNEUMATICO



**5** ESTRAENDO L'ATTREZZO L'AGO LASCERA' LA STRINGA NELLA GOMMA



## Mushroom tire repair standard



- Only for use with punctures penetration angle to the perpendicular of less than 20 °, if further utilize the pieces of repair.
- Material self vulcanizing Patch Rubber.
- Car-commercial vehicles-trucks.

Code	Desc.	Measures
3970012000	250	9X76 mm
3970011980	248	6x75 mm
3970011970	246	3x40 mm

## Mushroom repair radial tires and bias ply



- Only for use with punctures penetration angle to the perpendicular it is less than 20 °, if further utilize the pieces of repair.
- Material self vulcanizing SPEEDY PLUGS.
- Car-commercial vehicles-trucks.

Code	Desc.	Measures
3970012050	300	3X47 mm
3970012055	305	6X57 mm



## Patches for repairing inner tubes



- Material self vulcanizing.
- Provided in the box.
- Type of material "Chemical Cure".

Code	Desc.	Diam. mm	Form
3970011700	120	28	ROUND
3970011710	125	38	ROUND
3970011720	130	51	ROUND
3970011730	135	57	ROUND
3970011745	145	114	ROUND

## Patches for repairing tubeless radial



- Material self vulcanizing Patch Rubber.
- These patches are used to repair holes and damage to the radial tires of commercial vehicles-cars, trucks and earth moving.
- They have a special reinforcement that reduces the effects of the downturn.
- They can be used on the crown, shoulder and sidewall.

Code	Desc.	Measures	Form
3970011800	150	55X70 mm	SQUARE
3970011810	155	65X110 mm	SQUARE
3970011820	160	75X135 mm	SQUARE
3970011825	165	70X115 mm	SQUARE
3970011830	170	75x140 mm	SQUARE
3970011840	175	105x205 mm	SQUARE

## Universal patches for holes



- These patches are used to repair minor repairs on all types of tires of radial or diagonal weave cars-VI-truck-heavy.
- Both on inner tubes on both tubeless.
- To bore small holes - maximum 9mm.
- For repairs of crown-shoulder-hip.

Code	Desc.	Measures	Form	Applications
3970011900	180	45X45 mm	SQUARE	For holes up 3mm
3970011910	185	55X55 mm	SQUARE	For holes from 3 mm to 6 mm
3970011920	190	67X67 mm	SQUARE	For holes from 6 mm to 9 mm

## Diagonal patches CX



- Patches used to repair section, reinforcements, holes on car tires, industrial vehicles and earth moving.
- Suitable for applications also on bias ply tires, tubeless or with an air chamber.

Code	Desc.	Diam. mm	Form
3970011950	200	76	OCTAGONAL
3970011960	205	95	OCTAGONAL



## Solution for vulcanizing-bonding pieces mushrooms and strings



- Solution self vulcanizing.
- It has a quick-drying, speeds up the repair time.
- Eliminate defects in repairs due to incomplete drying time.
- Activates the chemical process that adheres units (pieces-fungi) to the tire.

Code	Description	Content	Characteristics
3970012100	350	200 ml	Transparent color, extra fast drying
3970012151	401 / Blue	200 ml	Blue-speed drying media

## Sealant heels tires



- It is a chemical solution to seal the tire beads.
- The heel is the part of the tire which in contact with the rim.
- Form a watertight seal between tire and rim, usable all times that the circle does not seal perfectly with the tire.
- Black Colour.

Code	Desc.	Content	Color
3970012152	402	Bead sealer-1 lt	black

## Sealant repairs



- It is a solution that allows you to seal the patch when applied and glued, covering the area where it is frosted excess tire for the application of the patch.
- Black Colour.

Code	Desc.	Content	Color
3970012150	400	Repair sealer-473 ml	Black

## Liquid for the cleaning of the tires



- Cleaning fluid, tires and inner tubes.
- Suitable for tire and repair shops generally.
- Allows the complete elimination of all contamination deposited around the injury (eg graphite, silicon, etc ..).
- Prepare the surface in an optimal way to allow for a speeding up of successive stages of repair.
- Effectively dissolves the release agent used in the production of tires. To be used after the operation of the buffing inside the tire, before applying the solution self vulcanizing (ns cod 3970012100).
- Particularly useful to remove residual adhesive left by balancing weights.
- Supplied with nozzle for accurate application of the liquid on the affected area.
- HOW TO USE:
- 1- After passing the wheel to apply the liquid to the working area and let stand for about 1 minute.
- 2- Remove the contamination using a scraper or a cloth.
- 3- proceed with the repair.

Code	Desc.	Content ml
3970012105	355	1000

## Specific product to remove all types of glue alloy wheels and steel



- Ready to use product for the easy cleaning of each type of surface to be hardened sealants.
- Effective on any type of sealant such as silicone, acrylic, polyurethane, MS polymer, etc ..
- Applicable on almost any surface without injuring it: raw metals and painted, ceramics, laminates, glass, aluminum.
- Do not use on surfaces made of nylon.

Code	Desc.	Color	Cont. ml
4110016480	4055	TRANSPARENT	400

## Bags brings tires



- Particularly suitable for tire.
- Many benefits to the end user: withdrawal of the replaced tire in a practical way, without the risk of getting dirty and smearing of the trunk of their car, tidy in the garage.
- Improve the quality and image of the service offered to the end customer certifying the attention and care for the goods of its customers. 1 Reel: 100 bags.
- Used with our wall mount plastic or metal cod cod 4440100250 4440101700.
- material color: white with Meccanocar logo or customer logo.
- Meccanocar gives the ability to customize the product with their own brands up to a maximum of 5 colors with a minimum quantity of 10 coils.
- Print Space: 2 reps max 300 x 300 mm.

Code	Desc.	Print
4440101800	100/M	Meccanocar
4440101805	100/1	1 color
4440101810	100/2	2 color
4440101815	100/3	3 color
4440101820	100/4	4 color
4440101825	100/5	5 color
4440101915	395/M	Meccanocar
4440101920	395/1	1 color
4440101925	395/2	2 color
4440101930	395/3	3 color
4440101935	395/4	4 color
4440101940	395/5	5 color

Tecnical Features	
Sheet count	100
Sack dimension mod.100	56+15+15*110 cm
Coil weight in Kg	6,7
Sack dimension mod.395	76+15+15*110 cm
Material	Polyethylene
Thickness	40 micron

## Labels for tires

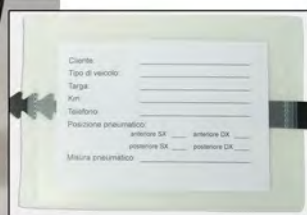

- Identification tags for tires.
- Suitable for tire dealers, repair shops, body shops.
- Allow quick and easy recognition of the tires of the end user during their stay in stock.
- Easy to apply on the tire thanks to clamp opened and closed.
- The paper labels are protected from humidity 'with the appropriate tags in reusable plastic over time.
- Set consists of 100 labels, tags 100 and 100 plastic ties.
- Label measures: 104 x 148 mm.
- Maximum diameter tire: 240 mm.

Code	Description
3970012400	470 - Complete set
3970012405	475 - Paper labels 100 pieces

## Coupons for tire adhesives



- Material: PVC adhesive.
- Practical coupons adhesives suitable for certify the servicing.
- Useful as a reminder to the end user in future inspections.
- Customization: Digital printing.
- Measurements: H150xL100 mm.
- On request the coupons can be fully customizable.
- Adhesive overwritten with crayon.

Code	Desc.
4720035390	2990

## TPMS-TYRE PRESSURE MONITORING SYSTEM

- Brief notes on TPMS
- What is TPMS = Tyre Pressure Monitoring System, which is the control system of the integrated tire pressure.
- It aims: increased safety, lower tire consumption, lower fuel consumption, lower emissions.
- Statement: starting from 01.11.2012 all new models of cars and campers must be equipped with a TPMS system, and from 1/11/2014, all registered passenger cars and campers must be equipped with a TPMS system.
- What types of TPMS exist: there is a DIRECT system, through sensors mounted behind the tire valve, pressure and temperature detect and constantly transmit information and INDIRECT system unit, through the tire speed determined by the EBS / ABS system, transmits information to the control unit that warns the driver via warning on the display.
- Advantages / disadvantages: Direct system is more accurate, it also works at a standstill and even the spare tire engine. The system Direct presents higher costs for maintenance, repair shops requires a greater set of tools and attention for maintenance.
- TPMS-Direct.
- Sensors: The Meccanocar sensors are universal and programmable.

### Sensors Schrader EZ-sensor



- Are the most used in valve sensors.
- European frequency 433Mhz.
- Reprogrammable and universal.
- Minimum battery life 5 years.

Code	Description	Characteristics
3970015000	Ez-Sensor Snap-in	Sensore europeo con valvola in gomma
3970015020	Valvola per Ez-Sensor Clamp-in	Valvola completa di ricambio e vite
3970015040	Valvola per Ez-Sensor Snap-in	Valvola completa di ricambio e vite per Ez-Sensor snap-in



## Sensors alligator sens.it



- Valve sensors.
- European frequency 433Mhz.
- Reprogrammable and universal.
- Minimum battery life 5 years.

Code	Description	Characteristics
3970015100	Sens.it Alligator sensore per valvole alluminio	Sensore europeo per valvole in alluminio
3970015110	Valvola Sens.it Alligator-Clamp-in alluminio	Valvola completa in alluminio per Sens.it Alligator
3970015120	Sens.it Alligator sensore per valvole in gomma	Sensore europeo per valvole in gomma
3970015130	Valvola Sens.it Alligator-Snap-in gomma	Valvola completa in gomma per Sens.it Alligator

## Sensors intellisens-huf/beru



- Valve sensors.
- European frequency 433Mhz.
- Programmable and universal.
- Minimum battery life 5 years.

Code	Description	Characteristics
3970015200	IntelliSens Huf/Beru Sensore universale UVS02	Sensore completo di valvola in alluminio modello UVS02
3970015210	Intellisens Huf/Beru sensore universale UVS4010	Sensore completo di valvola in alluminio

## Sensors vdo/continental redi-sensor



- Valveless sensors, non-programmable.
- European frequency 433Mhz.
- They are glued inside the tire and communicate directly with the control unit.
- Automatically interface.
- Minimum battery life 7 years.

Code	Description	Characteristics
3970015300	SENSOR 1	Per Bmw-Mini-Renault-Nissan-Opel-Chevrolet
3970015310	SENSOR 2	Per Volvo-Land Rover-Jaguar-Hyundai-Kia-Suzuki-Mitsubishi
3970015320	SENSOR 3	Per Toyota-Ford-Fiat
3970015330	SENSOR TOOLS	Utensile per montare il sensore nella slot in gomma quando si fa un cambio gomma.
3970015340	SLOT IN GOMMA	Slot in gomma senza sensore
3970015350	COLLA SENSORE/SLOT	9,6 gr di colla da mettere all'interno della slot

## Sensors cub unisensor



- Valve sensors.
- European frequency 433Mhz.
- Programmable and universal.
- Minimum battery life 5 years.
- They need their own CPU to be programmed.

Code	Description	Characteristics
3970015400	CUB 01-Sensore con valvola Snap-in	Sensore europeo con valvola in gomma

## Cpu BARTEC tech 500 and Interface for cub sensors



- Micro specific diagnosis computer for all TPMS systems, SCHRADER, HUF, ALLIGATOR, CUB, is the market leader for its incomparable coverage vehicles.
- Performs control of the vehicle to detect any faults, the program copying or creating new sensors using the main universal sensors.
- **With the appropriate interface, it can also program the Cub sensors.**
- TPMS reading and programming tool, all in one. Easy to use, large display with a clear Menu Updates simple software to download (for free the first year).
- solid design with a robust OBD connector and cable to use the workshop Communication PC via Bluetooth, WLAN or USB keyboard resistant to dust, water, oil and grease Long life of the internal battery, even loadable via USB.
- Decoding the signals coming from the sensors (OF, tire pressure, temperature and battery).
- The Kit includes Tech 500: Device Tech 500 User's Guide CD & OBD II cable USB cable USB charger Bluetooth Stick PC communication via Wi-Fi and Bluetooth wireless Reload (Standard Qi).
- The USB flash drive provides an easy connection thanks to Tech500 software. TECH 500 also interfaces with the TPMS desktop free application that offers a revolutionary technology to manage together with your complete, adjustable and storable reporting tool, management of multiple vehicles, look for TPMS information for a specific vehicle in quick manner.

Code	Description	Characteristics
3970015520	Bartech Tech 500	CPU
3970015530	Interfaccia Bartech per Cub	Kit Interfaccia per sensori Cub

## SERVICE KITS MECCANOCAR-TPMS



COLORE	COD.MECCANOCAR	cod. schrader & tpmseuroshop	APPLICAZIONE	Q.TA'
1	3970015620	65655-KD / 5002	Renault	8
2	3970015640	65657-KD / 5004	Lotus, Nissan, Volvo, Opel, Chevrolet, Peugeot	8
3	3970015660	65659-KD / 5006	Ford, Volvo, Mazda, Jaguar, Citroen, Fiat, Lancia, Land Rover	8
4	3970015720	65962-KD / 5017	Mercedes-Benz, Smart	8
5	3970015730	65963-KU / 5018	Renault	8
6	3970015840	66070-KU / 5020	Volvo, Ford, Jaguar, Land Rover	8
7	3970015770	66071-KU / 5021	Hyundai, Kia	8
8	3970015780	66072-KU / 5022	Mazda	8
9	3970015790	65731-67 / 5009	Audi, VW, BMW, Porsche	8
10	3970015810	65732-67 / 5010	Audi, VW, BMW, Porsche	8
11	3970015820	65733-67 / 5011	Audi, VW, BMW, Porsche	8
12	3970015800	65734-67 / 5012	Audi, VW, BMW, Porsche	8
13	3970015760	66118-68 / 5026	Peugeot, Opel, Hyundai, Citroen, Chevrolet	8
14	3970015700	65958-KU / 5015	Mercedes	8
15	3970015850	-	Tutti i veicoli	25
16	3970015860	-	Tutti i veicoli	25

- **SERVICE KITS MECCANOCAR-TPMS:** For maintenance at each tire change of the TPMS sensors OE components.
- In case there is the presence of TPMS, some components of the valves must be replaced. For each replacement tire, the TPMS Service Kit should be used to replace these components that are subject to wear such as the nut, the gasket, the internal mechanism and the cover. When changing the tires on a car without TPMS is normal replace valves; Therefore, even in the presence of TPMS sensors, you have to ensure the proper maintenance. This action, prevents breakage and avoids major damage and very expensive which could also result in the replacement of the entire sensor.
- **FEATURES AND BENEFITS OF THE RANGE MECCANOCAR-TPMS (briefcase assorted kit):**
  - The Service Kits covering more than 88% of all new European cars circulating in Italy;
  - It is made up of OE quality parts for guaranteed quality jobs;
  - All metal components are subjected to anti-corrosion treatment;
  - high quality seals ensure maximum reliability even in extreme conditions;
  - It is the ideal solution to optimize warehouse and to be always ready to handle any car you are facing.

Code	Desc.	Contenuto/Compatibile
3970015600	112-Service kit	112 articoli assortiti
3970015610	33B	Original Schrader 65654
3970015620	33C	Original Schrader 65655
3970015630	33D	Original Schrader 65656
3970015640	33E	Original Schrader 65657
3970015650	33F	Original Schrader 65658
3970015660	33G	Original Schrader 65659
3970015670	33H	Original Schrader 65660
3970015680	33H1	Original Schrader 43148-67
3970015690	33J	Original Schrader 65768
3970015700	33K	Original Schrader 65958
3970015710	33L	Original Schrader 65961
3970015720	33M	Original Schrader 65962
3970015730	33N	Original Schrader 65963
3970015740	33N1	Original Schrader 43611-68
3970015750	33P	Original Schrader 65964
3970015760	33Q	Original Schrader 65567
3970015770	33R	Original Schrader 66071-KU
3970015780	33S	Original Schrader 66072-KU
3970015790	33T	Original Schrader 65731-67/RDV001
3970015800	33U	Original Schrader 65734-67/RDV004
3970015810	33V	Original Schrader 65732-67/RDV002
3970015820	33W	Original Schrader 65733-67/RDV003
3970015830	33W1	Original Schrader 65086-67
3970015840	33X	Original Schrader 66070-KU
3970015850	33Y	KIT Interno valvola 25 pezzi
3970015860	33Z	Tappino valvola grigio 25 pezzi.



## Tools kit for TPMS



- Wera tools kit for the installation of the TPMS tire pressure monitoring systems.
- Required to install or replace the TPMS sensors and do the maintenance on TPMS valves.

**Contenuto Kit:**

Codice	Contenuto
3970016000	1 cacciavite a pistola dinamometrico-1 cacciavite porta bits dinamometrico - 1 cacciavite torx 10-1 punzone per valvole-1 adattore 1/4-1 bitz torx T20x50-1 bitz torx T15x50- 1 bussola esagonale da 1/4 da 12 e 1 bussola esagonale da 1/4 da 11
3970016010	Per inserti esagonali da 1/4, valore preimpostato Nm 3,3, precisione
3970016020	Cacciavite a pistola dinamometrico Nm 4 a Nm 8,8 per inserti esagono da 1/4
4200068502	Cacciavite Torx 10 x 65
4430056110	Adattatore da 1/4 es+1/4 quadro x 25
4200000150	Bussola 11 x 50 esagonale 1/4
4200000152	Bussola 12 x 50 esagonale 1/4
4430046786	Bitz Torx T15 x 50
4430046788	Bitz Torx T20 x 50

Code	Desc.	Photo
3970016000	744/61/9-Kit TPMS	-
3970016010	7461	1
3970016020	7443	2
4200068502	68502-TX 10	3
4430056110	1622/A	4
4200000150	414-11L	5
4200000152	414-12L	6
4430046786	751 TX T 15X50	7
4430046788	751 TX T20X50	8





# Welding

Ossigas welding .....	pag. 1662	Tin welding.....	pag. 1687
Electrode welding and TIG .....	pag. 1670	Consumables for Spotter.....	pag. 1693
Wire welding .....	pag. 1677	Personal protection .....	pag. 1697
Plasma cutting .....	pag. 1685		

**COMPOSIZIONE PER SALDARE**

**Interchangeable torch spears**

- Universal use.
- Welding, brazing and cutting thicknesses from 0.4 to 175 mm.
- One-piece body forged aluminum.
- Detachable hose for 6 to 10mm.

Code	Desc.
4020002700	553

**Lance for welding and braze welding**

- For acetylene.
- To handle n / s art. 402 00 02700-553.

Code	Descr. Lt/h	Spessore saldabile
4020001500	40 LT	0,4 mm
4020001600	80 LT	0,8 mm
4020001700	160 LT	2 mm
4020001800	225 LT	3 mm
4020001900	315 LT	4 mm
4020002000	500 LT	5 mm
4020002050	800 LT	8 mm

**Replacement tips for spears by welding**

- For acetylene.
- Caution: Do not mount the lance tips of magnitude different from the original, the sizes printed on the tip and on the lance must match.

Code	Desc.	Spessore saldabile
4020005200	540393	0,4 mm
4020005300	540401	0,8 mm
4020005400	540419	2 mm
4020005500	540427	3 mm
4020005600	540435	4 mm
4020005700	540476	5 mm
4020005800	540484	8 mm

## Cutting Attachment tap



- Cutting lance with standard tap water, mixing system by aspiration. The gas is mixed in the handle and comes already ready to tip for maximum cutting quality.
- Possibility to mount monobloc our tips for a better flame and a gas consumption lower.

Code	Desc.
4020006100	508143

## Monobloc tip for cutting lance 508,143-Acetylene



- Cutting Bits block for mounting on our launches cod. 402 00 06,100 to 508,143.
- The construction allows to obtain a flame straighter and thermally efficient machining with the best and great savings in gas.
- Increased security during processing, lower risk of clogging of the holes.

Code	Desc.	Cutting capacity
4020006200	545103	5-15 mm
4020006300	545111	15-25 mm
4020006400	545129	25-50 mm
4020006500	545137	50-75 mm

## Cutting Attachment lever



- Cutting Attachment drive lever, gas mixing toe for greater job security.
- The mixing system reduces practically to zero the path of the gases already mixed, minimizing the danger of backfiring.
- Use with automix tips to attack international IC.

Code	Desc.
4020008200	508499

## IC tips for cutting lance 508,499 -Acetilene



- Cutting tips with international attack IC for mounting on our cutting lance code. 402 00 08,200 to 508,499.
- The mixing inside the tip allows to obtain the maximum processing safety and best quality of cut.

Code	Desc.	Cutting capacity
4020009250	46500	3-10 mm
4020009260	46550	10-25 mm
4020009270	46600	25-75 mm
4020009280	46650	75-125 mm
4020009290	46700	125-175 mm

## IC cutting tips for propane-LPG-CNG



- Cutting Bits special copper and brass for use with fuel gases propane, LPG and CNG. Suitable for use on all sets cutting mount IC, like our item code 402 00 08,200 to 508,499.
- Version in two separable pieces for cleaning. Wide range of cutting capacity.

Code	Description	Cutting capacity mm	OX consumption	Gas consumption
4020017190	13724	3-10	1,4 m3/h	0,3 m3/h
4020017200	13725	10-25	3 m3/h	0,4 m3/h
4020017210	13726	25-75	8 m3/h	0,5 m3/h
4020017220	13727	75-125	15 m3/h	0,6 m3/h
4020017230	13728	125-175	20 m3/h	0,7 m3/h

## Cutting tips for propane-LPG-CNG



- Punta da taglio in rame speciale ed ottone per l'utilizzo con gas combustibili Propano, GPL e Metano. Indicate per l'utilizzo su tutte le lance da taglio tipo il nostro articolo codice 402 00 06100-508143.
- Versione in due pezzi separabili per la pulizia. Ampia gamma di capacità di taglio

Code	Description	Cutting capacity mm	Pressure bar ox./gpl
4020017150	13720	10-15	2,5 / 0,2
4020017160	13721	15-25	3,0 / 0,2
4020017170	13722	25-50	3,5 / 0,2
4020017180	13723	50-75	4,0 / 0,3



## Twin hose for technical gases



- Double hose rubber hose.
- Welding and oxy-gas cutting.
- Colours of gas (blue and red).
- Rubber cover smooth wear.
- Marking with technical guidance.
- Complies with EN 559.

Code	Desc.	Ø mm
4020007000	1105642	8x15
4020007050	1105642/10	10x17

## Pressure regulators for industrial gases



- Robust and reliable pressure reducing valves for technical gases in cylinders, pressure resistant up to 230 bar.
- High stability of supply.
- Fittings of entry and exit differentiated for the different types of gas according to UNI.
- Outlet fittings for rubber hose  $\varnothing$  8 mm and 10 mm.

Code	Desc.	For gas	Photo
4020007200	600437	OXYGEN	1
4020007300	610469	ACETYLENE	2
4020007350	622258	PROPANE	3
4020007250	610468	ACETYLENE	4
4020007150	610469	OXYGEN	5

## Cleaning Kit for tips ossigas



- Practical case containing a series of reamers for cleaning holes of the tips for welding or cutting ossigas.
- Keep clean and efficient tips allows you to work safely and to always have a perfect flame, avoiding sudden shutdowns torch.

Code	Desc.
4020012300	13110



## Safety valves for pressure reducers



- Safety devices against flashbacks from malfunction or misuse of the ossigas.
- Robust construction in forged brass valve with stainless steel inner and vent valve to prevent damage to the pipes.
- Manufactured according to EN 730-1.
- Available for oxygen and combustible gases.
- **IMPORTANT:** the devices have a maximum maturity of five years, and must be replaced anyway in case of backfiring.

Code	Desc.	For gas
4020007400	1102375	Oxygen
4020007500	1102409	Acetylene

## Safety valves for handgrips



- Safety devices against flashbacks from malfunction or misuse of the oxygen to be applied on the handle instead of herringbone gas inlet.
- Rugged construction in cast aluminum with internal valve in stainless steel with controlled porosity and certified for the arrest of flame.
- Manufactured according to EN 730-1.
- Available for oxygen and combustible gases.
- **IMPORTANT:** the devices have a maximum maturity of five years, and must be replaced anyway in the event of a flashback.

Code	Desc.	For gas
4020008800	1102140	oxygen
4020008810	1102145	acetylene

## Safety valves hose-pipe



- Safety devices against the returns of Famma by malfunction or misuse of the ossigas be applied between two tube sections.
- Rugged construction in cast aluminum with stainless steel internal valve to prevent damage to the pipes.
- Manufactured according to EN 730-1.
- Available for oxygen and combustible gases.
- **IMPORTANT: the devices have a maximum maturity of five years, and must be replaced anyway in the event of a flashback.**

Code	Desc.	For gas
4020007600	1103209	Oxygen
4020007700	1103217	Acetylene

## Chopstick for the welding of iron and steel in gender



- Finger in annealed iron for the welding of iron and steel in general.
- High malleability, suitable for use in hydrothermal fields, health care, art, carpentry.
- It complies with DIN 8554, AWS A5.2: R45.

Code	Desc.	Dimensions mm
4020000900	219/2	2X1000
4020000910	227/3	3X1000

Technical Features	
Punto medio di fusione	1530° C
C	0.08%
Si	0.03%
Mn	0.50%
P	0.025%
S	0.025%
Cu	0.11%
Rm	450 N/mm <sup>2</sup>

## Copper silver chopsticks



- Finger bare copper-phosphorus alloy with 5% silver.
- Suitable for brazing copper alloys in the fields plumbing and heating, refrigeration, electrical.
- Unions in copper-copper alloy and 'self-fluxing'.
- Complies with DIN 8513: L Ag5P, AWS A5.8A, BCuP3.

Code	Desc.	Dimensions mm	Qty. Kg/nr
4020012400	13120	2x500	1,0/75

Technical Features	
Punto medio di fusione	710°C
Ag	5.00%
P	6.00%
Cu	89.00%

## Copper silver chopsticks



- Finger bare copper-phosphorus alloy with 5% silver.
- Suitable for brazing copper alloys in the fields plumbing and heating, refrigeration, electrical.
- Unions in copper-copper alloy and 'self-fluxing'.
- Complies with DIN 8513: L Ag5P, AWS A5.8A, BCuP3.

Code	Desc.	Dimensions mm	Qty. Kg/nr
4020003160	210/B2	2x500	0,5/35
4020003170	211/B3	3x500	0,5/16

Technical Features	
Punto medio di fusione	880°C
Si	0.20%
Zn	39.00%
Cu	60.00%

## Generic chopsticks for aluminum



- Finger aluminum flux built for welding aluminum and its alloys in extruders, evaporators, chassis, bus bars, pipes and refrigerators in building the frames.
- In conformity, AWS A5.10: ER 1100.

Code	Desc.	Dimensions <i>mm</i>	Qty. Kg/nr
4020003200	208/2	2x850	1,0/76
4020004600	216/3	3x850	1,0/50

Tecnical Features	
Al	99.50%
Rm	90 N/mmq.
Punto medio di fusione	630°C

## Silver alloy chopsticks coated (Argentana)



- Wand high silver content with coating flux for brazing of copper alloys, steel and stainless steels.
- Suitable for processing in precision mechanics and delicate work in the sectors water & heating, air conditioning, cooling circuits, electrical contacts.
- Complies with DIN 8513: L-Ag40Cd.

Code	Desc.	Dimensions <i>mm</i>	Qty. Kg/nr
4020005000	0822114-Ag12S-1.5	1.5x500	0,25/19
4020005100	0822122-Ag12S-2	2x500	0,25/11

Tecnical Features	
Rm	310 N/mmq.
Punto medio di fusione	610°C
Sn	20.00%
Zn	21.00%
Cu	19.00%
Ag	40.00%

## Guida applicativa alla scelta del metallo d'apporto per la saldatura ossigas

NATURA DEI METALLI DA UNIRE	RAME	OTTONE	FERRO ACCIAIO	INOX	ALLUMINIO	GHISA	LAMIERE ZINCATE
<b>RAME</b>	402 00 05000 402 00 05100 402 00 12400 402 00 12500	402 00 05000 402 00 05100	402 00 03160 402 00 03170 402 00 05000 402 00 05100	402 00 05000 402 00 05100	-----	402 00 03160 402 00 03170	402 00 05000 402 00 05100
<b>OTTONE</b>	402 00 05000 402 00 05100	402 00 03160 402 00 03170 402 00 05000 402 00 05100	402 00 05000 402 00 05100	402 00 05000 402 00 05100	-----	402 00 03160 402 00 03170	402 00 05000 402 00 05100
<b>FERRO ACCIAIO</b>	402 00 03160 402 00 03170 402 00 05000 402 00 05100	402 00 05000 402 00 05100	402 00 00900 402 00 00910 402 00 03160 402 00 03170	402 00 05000 402 00 05100	-----	402 00 03160 402 00 03170	402 00 05000 402 00 05100
<b>INOX</b>	402 00 05000 402 00 05100	402 00 05000 402 00 05100	402 00 05000 402 00 05100		-----	402 00 03160 402 00 03170	402 00 05000 402 00 05100
<b>ALLUMINIO</b>	-----	-----	-----	-----	402 00 03200 402 00 04600	-----	-----
<b>GHISA</b>	402 00 03160 402 00 03170	402 00 03160 402 00 03170	402 00 03160 402 00 03170	402 00 03160 402 00 03170	-----	-----	402 00 05000 402 00 05100
<b>LAMIERE ZINCATE</b>	402 00 05000 402 00 05100	402 00 05000 402 00 05100	402 00 05000 402 00 05100	402 00 05000 402 00 05100	-----	402 00 05000 402 00 05100	402 00 05000 402 00 05100

CODICE	APPLICAZIONI	TIPO DI DISSODANTE
<b>402 00 00900-219/2</b> <b>402 00 00910-227/3</b>	<b>PROFILATI</b> <b>SCATOLATI</b> <b>ARTISTICO</b>	-----
<b>402 00 03160-210/B2</b> <b>402 00 03170-210/B3</b>	<b>PER UNIONE E RIPORTI DI:</b> <b>FERRO</b> <b>BRONZO</b> <b>OTTONE</b> <b>RAME</b> <b>MARMITTE</b>	-----
<b>402 00 12400-13120</b> <b>402 00 12500-13130</b>	<b>PER SALDATURE E BRASATURE DI:</b> <b>RAME</b> <b>BRONZO</b> <b>OTTONE</b> <b>TERMO-SANITARIA</b> <b>ROTORI ELETTRICI</b> <b>CAPICORDA ELETTRICI</b> <b>SCAMBIATORI DI CALORE</b>	-----
<b>402 00 03200-208/2</b> <b>402 00 04600-216/3</b>	<b>PER UNIONE E RIPORTI SU</b> <b>ALLUMINIO SENZA DISSODANTE</b>	-----
<b>402 00 05000-0822114</b> <b>402 00 05100-0822122</b>	<b>NICHEL E SUE LEGHE</b> <b>METALLI PREZIOSI</b> <b>MANICOTTI PER</b> <b>IDROTERMOSANITARIA</b> <b>CONDIZIONAMENTO-OCCHIALI</b> <b>BIGIOTTERIA</b> <b>CIRCUITI DI RAFFREDDAMENTO</b> <b>CONTATTI ELETTRICI</b> <b>METALLI DURI (INOX, ECC.)</b>	-----



## Rutile electrodes for common steels



Posizioni saldatura:



Corrente: AC/DC -

Approvazioni e Classificazioni	Composizione chimica %	Caratteristiche meccaniche
CE, EN 13479 SFA/AWS A5.1: E6013, EN ISO 2560-A, E38 0 R 12	C: 0,06 – Mn: 0,4 – P: 0,02 S: 0,01 – Cr: <0,1 – Ni: <0,1 Mo: <0,1 – Nb: 0,1 – Cu: <0,1 V: 0,01	Rs: 360 N/mm <sup>2</sup> Rm: 500 N/mm <sup>2</sup> KV: 40 Joule a 0°C

- Electrode with rutile coating of medium thickness.
- Type easy to use, sliding and of great aesthetic.
- Arco sweet and quiet, splashing almost 'non-existent', slag that detach themselves. Ignition and re-ignition very easy.
- The features and the kind it can be used in any general work and any construction on average solicited.
- Indicated for works of small and medium carpentry, for structural steels, and for pressure tanks.

Code	Desc.	D mm	L mm
4020000300	513	2	250
4020000400	521	2.5	260
4020000500	539	3.25	360

## Rutile coated red for common steels



Posizioni saldatura:



Corrente: AC/DC -

CLASSIFICAZIONI	COMPOSIZIONE CHIMICA VALORI TIPICI %	CARATTERISTICHE MECCANICHE DEL DEPOSITO
	C: 0,07 Si: 0,4 Mn: 0,5	Rs: 360 N/mm <sup>2</sup> Rm: 500 N/mm <sup>2</sup> δ5: 24% KV: 40 J a 0°C

- Coating electrode with rutile medium thickness with the addition of Fe<sub>2</sub>O<sub>2</sub> that, in addition to the particular red coloration, gives a better performance to the electrode.
- Type easy to use, sliding and of great aesthetic.
- Arco sweet and quiet, splashing at unsustainably debris that fall off by themselves. Ignition and re-ignition very easy.
- The features and the kind it can be used in any general work and any construction on average solicited.
- Indicated for works of small and medium carpentry, for structural steels, and for pressure tanks.

Code	Desc.	D mm	L mm
4020002200	624	2.5	300

## Basic electrodes for mild steel



Posizioni saldatura:



Corrente: AC/DC -

Approvazioni e Classificazioni	Composizione chimica %	Caratteristiche meccaniche
ABS: 3Y H5, BV: 3YH5 CE: EN 13479 DNV: 4YH5 GL: 4YH5 LR: 3YH5 RINA: 4YH5 VdTUV: 11813 SFA/AWS A5.1: E7018-1 H4R: EN ISO 2560-A E 42 4 B 32 H5	C: 0,07 Si: 0,51 Mn: 1,16 P: 0,016 S: 0,006 Cr: 0,03 Ni: 0,02 Nb: <0,1 Cu: <0,1 V: 0,02	Rs: 500 N/mm <sup>2</sup> Rm: 570 N/mm <sup>2</sup> KV: 70 Joule

- Ellettrodo Basic coating of medium thickness.
- Low hydrogen, of consistently high quality, with excellent mechanical properties.
- Welding of responsibility and of the greatest importance mechanical, radiographic and sealing.
- Recommended in all cases of welding of structures with high-quality steels with lower carbon contents up to 0.30% and with impurities such as sulfur and phosphorus.
- It is used for shipbuilding, railway industries, vehicles, pressure pipes, tanks and high-pressure boilers, heavy carpentry, bridges, etc..
- Approval: RINA-ISPESL.

Code	Desc.	D mm	L mm
4020000600	329	2.5	350
4020000700	337	3.25	450
4020007900	1902345	4	450



## Basic electrodes for hardfacing



- Basic electrode with excellent weldability in all positions.
- Excellent performance both in direct current (+ pole) and alternating current.
- Suitable for welding of steels tough, high sulfur or rusty. It presents a bead of good appearance.
- Designed for all maintenance and repair.
- It is used for shipbuilding, welding of boilers, pressure vessels as well as repairs of vehicle frames, machines and pipes for heating.



Approvazioni e Classificazioni	Composizione chimica %
EN 14700 E Z Fe 2	Mn: 0,4 Mo: 0,5 C: 0,46 Si: 0,5 Cr: 6,0

Code	Desc.	D mm	L mm
4020003500	537	3.25	350

## Electrodes for welding stainless steel 308



- Rutile electrode giving a deposit of austenitic stainless steel type 19/9 with very low carbon content.
- Excellent operation both in direct current and in alternating current.
- Suitable for welding of stainless steels meet the following classifications: AISI 301, 302, 304, 304L, 308, 321, 347.

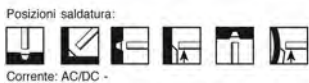

Approvazioni e Classificazioni	Composizione chimica %	Caratteristiche meccaniche
EN ISO 3581-A; E 19 9 L R 12 SFA/AWS A5.4; E308L-17 CSA W48; E308L-17 Werkstoffnummer: 1.4316	C: 0,03 Si: 0,84 Mn: 0,7 O: 0,02 S: 0,007 Cr: 19,5 Ni: 9,7 Mo: 0,04 Cu: 0,06 N: 0,08 FN WRC-92: 6,0	Rs: 430 MPa Rm: 580 MPa KV: 70 Joule a +20°C

Code	Desc.	D mm	L mm
4020000990	117	2	300
4020001000	125	2.5	300

## Electrodes for welding stainless steel 316



- Titanium electrode giving a deposit of austenitic stainless steel type 19/12 with a very low carbon content.
- Good operating characteristics both in direct current and in alternating current.
- Suitable for welding of stainless steels meet the following classifications: AISI 316, 316L, 202, (317).



Approvazioni e Classificazioni	Composizione chimica %	Caratteristiche meccaniche
EN ISO 3581-A; E 19 12 3 L R 12 SFA/AWS A5.4; E316L-17 CSA W48; E316L-17 Werkstoffnummer: 1.4430	C: 0,03 Si: 0,73 Mn: 0,6 P: 0,021 S: 0,009 Cr: 18,8 Ni: 11,3 Mo: 2,7 Cu: 0,07 N: 0,14 FN WRC-92: 4	Rs: 460 MPa RS: 570 MPa KV: 60 Joule a +20°C

Code	Desc.	D mm	L mm
4020002400	216	2	300
4020002410	217	2.5	300

## Welding inverter electronic 140-160 A



- Electronic welding machines portable inverter technology for welding with coated electrodes. Suitable for welding of iron and stainless steel TIG with contact striking. Power single-phase current 220 Volts 50 Hz.
- Indicate for each type of processing, especially on construction sites thanks to their portability and light weight and low current consumption. Be powered by motor generators type stabilized adequate power.
- The version 1425M has a power supply circuit reinforced for use with motor-generators is not stabilized or in areas where there are significant power surges harmful to electronic machines Classic.
- Constructed entirely of painted steel frame, internal motherboard with forced cooling fan, frontal attacks DINSE 25 standards for the application of any type of cable of 16-25 sq mm.
- The machines are supplied in a cardboard box, without accessories. For cables is available our kit code 402 00 01350-11K or loose components for building customized. The availability of masks is large and varied models manual to automatic darkening.

Code	Desc.	Model
4020017090	1425	Portable welding inverter 220 Volts 140 A
4020017100	1625	Portable welding inverter 220 Volts 160 A
4020017110	1425M	Portable welding inverter 220 Volts 140 A "motor generator"

Caratteristiche Tecniche						
Modello	1425 - 1425M			1625		
Alimentazione	220 Volts - 50 Hz			220 Volts - 50 Hz		
Potenza	2,5 kW			3 kW		
Corrente di saldatura	10 - 140 A			10 - 160 A		
Fattore di servizio	20%	60%	100%	20%	60%	100%
	130A	90A	70A	150A	105A	90A
Elettrodi utilizzabili	1,6 - 3,2 mm			1,6 - 4 mm		
Norme di costruzione	EN60974-1 EN60974-10			EN60974-1 EN60974-10		
Dimensioni	135 X 290 X 230h mm			135 X 290 X 230h mm		
Peso	4,5 Kg			4,8 Kg		

## Cable kit for welding coated electrodes



- Cables for arc welding with coated electrodes.
- Content: clamp electrode holder with cable 3 m long, clamp with cable length of 2 m.
- Cables neoprene section of 25 mm<sup>2</sup>.

Code	Desc.
4020001350	11 K

## Hammer for welders



- Hammer two-headed welder.
- For removing welding slag.
- Iron grip.

Code	Desc.
4430045642	602

## Copper cable for welders



- Unipolar wire copper coated neoprene extra flexible.
- Construction and marking according to current regulations.

Code	Desc.	Sez. mmq	D. est. mm
4020011950	12800	25	10
4020012000	12900	50	13
4020012100	13000	70	16

## Male connectors for welding



- Male connectors for connecting the cables to the welding.
- Available in three sizes for different cable sections.

Code	Desc.	For sect. cables mmq	D mm
4020001300	10-25	25	9
4020001310	10-50	50	13
4020001320	10-70	70	13

## Pliers electrode holder



- Pliers electrode holder completely isolated.
- Suitable for intensive use with excellent characteristics of fastening of the electrode.
- High impact resistance.
- Complies with CE EN 60974-11
- Insulation class: B.

SIMBOLI TECNICI	600
	520 A al 35%
	MAX 50 mm <sup>2</sup>
	MAX 8 mm

Code	Desc.	Weight gr.	For electrodes diam. Max. mm	A (35%)	Sezione max cavo mmq
4020001050	300	315	4,0	250	35
4020001100	600	580	8,0	500	50

## Clamp for mass



- Clamp for mass pressed steel.
- Spring locking.
- Copper and brass contact strip of a copper connection.

Code	Desc.
4020001200	400

## Brass clamp for mass



- Earth clamp designed for use industrialie very intense.
- Made entirely of cast brass for maximum electrical and thermal conductivity.
- Securing the cable made by brass screws.

Code	Desc.
4020001250	400/BR

## Tig welding torch



- Torch complete with cable and connection for the welding process "TIG" (Tungsten Inert Gas).
- Equipped with a valve for regulating the flow of the gas.
- Cable length of 4 m.
- To be used in conjunction with bottled gas "Argon" through pressure reducer type ns. art. 402 00 11,500 to 12,140.
- Supplied as standard for use with Ø1.6 electrodes, for use with electrodes ø2.4 provide pliers and calliper ns. Articles. 402 00 11750 to 12400, 11850 to 12600 00 402.

Code	Desc.	Length m
4020011300	12-TIG	4

## Tungsten electrodes for TIG welding



- Tungsten electrodes for welding process "TIG".
- Models available: with 21% thorium specific for stainless and steel.
- Available in two diameters.

Code	Desc.	Ø mm	Tipo elettrodo	Color
4020011400	13 - 1.6/T	1.6	THORIATED	Red
4020011410	13 - 2.4/T	2.4	THORIATED	Red
4020011440	16 - 1.6	1.6	PURE	Green
4020011450	16 - 2.4	2.4	PURE	Green

## Ceramic gas diffuser for TIG torch



- Diffuser ceramic parts for our torch code 402 00 11300-12 / TIG.
- The hole diameter of the gas outlet 8 mm.

Code	Desc.
4020011650	12200

## Pliers holders for TIG torch



- Pliers holder turned brass for our torch cod. 402 00 11300-12 / TIG.
- Available for two diameters of electrode.

Code	Desc.	Cutting capacity
4020011700	12300	1.6
4020011750	12400	2.4

## Pliers for TIG torch



- Pliers turned brass for our torch cod. 402 00 11300-12 / TIG.
- Available for two diameters of electrode.

Code	Desc.	Cutting capacity
4020011800	12500	1.6
4020011850	12600	2.4

## Pens parts for TIG torches



- Pens long and short parts for TIG torch cod. 4020011300 and 4020014800.

Code	Desc.	Length mm	Photo
4020011310	12L	100	2
4020011320	12C	7	1



## Filler chopstick for TIG welding of aluminum



LEGHE ALLUMINIO-SILICIO

CLASSIFICAZIONI	COMPOSIZIONE CHIMICA VALORI TIPICI %
AWS A5.10: ER 4013 DIN 1732 SG- Al Si 5 W n° 3.2245	Fc 0.30 Si 5.00 Mg 0.05 Al 93.00

LEGHE ALLUMINIO-MAGNESIO

CLASSIFICAZIONI	COMPOSIZIONE CHIMICA VALORI TIPICI %
AWS A5.10: ER 5356 DIN 1732 SG- Al Mg 5 W n° 3.3556	Fc 0.30 Si 0.20 Mg 5.00 Al 93.00

- Filler material in chopsticks for welding with TIG method of aluminum and its alloys.
- Available for aluminum-silicon alloys and aluminum-magnesium.

Code	Desc.	Dimensions mm	Alloy
4020012200	13100	2.4x1000	Al-Mg
4020012210	13105	2.4x1000	Al-Si

## Filler chopstick for TIG welding of stainless steels



Acciaio AISI 308

CLASSIFICAZIONI	COMPOSIZIONE CHIMICA VALORI TIPICI %	CARATTERISTICHE MECCANICHE DEL DEPOSITO
AWS A5.9: ER308L DIN 8556 X2CrNi9-9	C = 0.025 Si = 0.40 Mn = 1.80 Cr = 20.00 Ni = 10.00	Rm = 530 N/mmq. Rs = 400 N/mmq. A(50) = 40% KV = 130 J

Acciaio AISI 316

CLASSIFICAZIONI	COMPOSIZIONE CHIMICA VALORI TIPICI %	CARATTERISTICHE MECCANICHE DEL DEPOSITO
AWS A5.9: ER316L	C = 0.025 Si = 0.40 Mn = 1.60 Cr = 18.50 Ni = 12.50	Rm = 530 N/mmq. Rs = 390 N/mmq. A(50) = 35% KV = 130 J

- Filler material in chopsticks for welding with TIG method of stainless steel AISI 308 and 316.
- Excellent resistance to chemical corrosion, low carbon content.

Code	Desc.	Dimensione mm	AISI steel
4020012850	13165	1,6x1000	308
4020012900	13170	2x1000	308
4020013000	13180	2x1000	316

## Filler chopstick for TIG welding of carbon steel



- Filler material into rods for TIG welding with carbon steel.
- Excellent mechanical properties and toughness.

CLASSIFICAZIONI	COMPOSIZIONE CHIMICA VALORI TIPICI %	CARATTERISTICHE MECCANICHE DEL DEPOSITO
AWS A5.18 ER70S-3 DIN 8559WSG1	C = 0.007 Si - 0.60 Mn = 1.20	Rm = 520 N/mmq. Rs = 420 N/mmq. A(50) = 29% Kv = 80J

Code	Desc.	Dimensions mm
4020012800	13160	2x1000

## Welding wire for generic steels



- Welding wire of sg2 type with external copper universal application suitable for general steels, such as type FE45.52.
- Suitable for use in all sectors such as carpentry, locksmiths, car body, processing factories, construction sites, etc.
- Product dedicated to the construction generally, metal structures, boilers, tanks, pipes.
- Convolution of coil winding on spools of 16 kg, random coils of 5 kg. steel coils k300 16 kg, 5 kg plastic. shielding gases: CO2 or mixture (M21 - M33).
- REGULATIONS: AWS A5.18; ER70S-6; EN ISO 14341; A: G464MG3Si1

Code	Description	Diam. mm	Weight Kg.	Coil
4020000200	5	0.6	5,0	Plastica
4020000250	6	0.8	5,0	Plastica
4020016990	13656	0.8	16,0	Ferro
4020016995	13657	1,0	16,0	Ferro
4020017000	13658	1.2	16,0	Ferro

COMPOSIZIONE CHIMICA TIPICA %											
C	Si	Mn	S	P	Cu	Ni	Cr	Mo	Al	V	N
0,06	0,835	1,42	0,01	0,014	0,048	0,024	0,036	0,005	0,003	0,006	0,007

NORMATIVE
AWS A5.18
ER70S-6
EN ISO 14341
A:G464MG3Si1

**Caratteristiche meccaniche del riporto.**  
**Rm:** 565 Mpa  
**Rs:** 465 Mpa  
**A5d:** 29%  
**Kv (-30°C):** 85 Joule

## Welding wire of stainless steel AISI 304-308



- Recommended for machining of stainless steels in the construction of objects of all kinds, and for the construction of cryogenic plants that work at very low temperatures.
- Winding coil on coil in rolls of 15 kg steel k300.
- Gas protection to use: 100% argon or argon + 2% oxygen. 18-20 liters / minute.
- REGULATIONS: AWS A5.9 / A5.9M; ER308LSI; ISO 14343-A-19 9 LSI

Code	Description	Diam. mm	Weight Kg.	Coil
4020009100	308-0.8	0.8	15,0	Metallo
4020009110	308-1	1,0	15,0	Metallo
4020009120	308-1.2	1.2	15,0	Metallo

COMPOSIZIONE CHIMICA TIPICA %											
C	Mn	Si	S	P	Cr	Ni	Mo	Cu	Co	N	
0,013	1,90	0,78	0,009	0,017	19,76	10,71	0,09	0,09	0,003	0,005	

NORMATIVE
AWS A5.9/A5.9M
ER308LSI
ISO 14343-A-19 9 LSI

**Ferrite %: 7,30 FERRITE SECONDO DELONG. IL VALORE E' INDICATIVO**  
**Caratteristiche meccaniche del riporto.**  
**Rm:** 580 Mpa  
**Rs:** 450 Mpa  
**A5d:** 38%  
**Kv (20°C):** 100 Joule

## Welding wire of stainless steel AISI 316



- Recommended for machining stainless steels in construction carpentry, boats, appliances, metal work including chemical and oil, pipes.
- Winding coil on coil in rolls of 15 kg steel k300. shielding gas to be used: argon + 2.1% oxygen. 18-20 liters / minute.
- REGULATIONS: AWS A5.9 / A5.9M; ER316LSI; ISO 14343-A-19 12 3 LSI

Code	Description	Diam. mm	Weight Kg.	Coil
4020009200	316-0.8	0.8	15,0	Acciaio
4020009210	316-1	1,0	15,0	Acciaio
4020009220	316-1.2	1.2	15,0	Acciaio

COMPOSIZIONE CHIMICA TIPICA %																
C	Mn	Si	S	P	Cr	Ni	Mo	Cu	Co	N	Ti	Nb+Ta	B	V	Sn	
0,019	1,82	0,79	0,009	0,019	18,21	12,16	2,54	0,17	0,06	0,057	0,011	0,016	0,0009	0,07	0,004	

NORMATIVE
AWS A5.9/A5.9M
ER316LSI
ISO 14343-A-19 12 3 LSI

Ferrite %: 4,80 FERRITE SECONDO DELONG. IL VALORE E' INDICATIVO

Caratteristiche meccaniche del riporto.

Rm: 600 Mpa  
Rs: 400 Mpa  
A5d: 30%  
Kv (20°C): 47 Joule

## Aluminum welding wire AlMg5

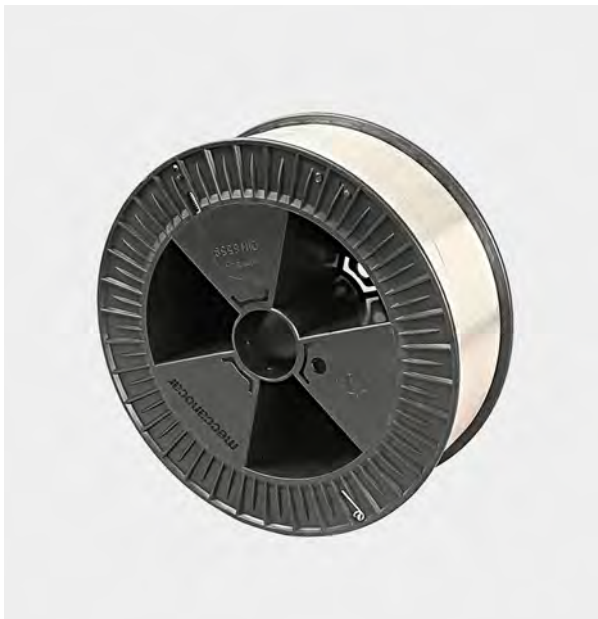

- Aluminum magnesium alloy wire designed for welding of sheet metal and aluminum profiles 5050, 05052, 05083, 05154, 05356, 06061 and 6063
- Suitable for processes such structures truck, engine stands, alloy wheels, ship superstructures, structural steel and architectural structures.
- Good corrosion resistance, can be used on metals where it is not possible for the heat treatment after welding to increase mechanical resistance.
- Winding coil on coil in coils from 7 kg plastic.
- Gas protection to use: pure argon, argon-helium mixtures.
- Measures to be taken: use torches as short as possible, keep the cable stretched and without sharp bends, use Teflon line guide sheaths.
- REGULATIONS: AWS A5.10; ER5356; ISO ER SA5356; UNS A95356

Code	Desc.	D mm	Weight Kg.	Coil
4020009000	5356-0.8	0.8	7	Plastica
4020009010	5356-1	1	7	Plastica
4020009020	5356-1.2	1.2	7	Plastica

COMPOSIZIONE CHIMICA TIPICA %						
Al	S	Fe	Mn	Mg	Cr	Zn+Ti
bal	0,25	0,40	0,15	4,5-5,6	0,80	0,25

NORMATIVE
AWS A5.10
ER5356
ISO ER SA5356
UNS A95356

Caratteristiche meccaniche del riporto.

Rm: 230 Mpa  
Rs: 195 Mpa  
A5d: 12%



## Wire for welding galvanized sheet



- Special steel wire specific for the welding of galvanized sheets and galvanized.
- Ideal for welding of sheet metal parts and chassis in vehicle and in the transformation of the media, in the naval sector and carpentry in general.
- The composition of the yarn and the particular protective coating eliminate any problem of interference with the galvanizing surface, low spatter formation and limited "boiling" of the weld pool.
- Packs of 5 kg of small coils.
- REGULATIONS: AWS A5.18; ER 70S-2; ISO14341-A; G2TI.

Code	Desc.	Ø filo mm	Weight Kg.
4020000280	10	0,6	5
4020000290	11	0,8	5

COMPOSIZIONE CHIMICA TIPICA %									
Fe	C	Si	Mn	Al	Ti	Cu	Zr	S	P
Base	0,06	0,6	1,2	0,1	0,1	0,2	0,08	0,01	0,015

NORMATIVE
AWS A5.18
ER70S-2
ISO14341-A
G2TI

**Caratteristiche meccaniche del riporto.**  
**Rm:** 560 Mpa  
**Rs:** 460 Mpa  
**A5d:** 28%

## Wire solder copper-silicon for galvanized steel and steel with a high elastic limit (THLE)



- Special wire for welding of low-temperature galvanized sheet metal and steels with high and very high elastic limit, of the type used in modern bodies and chassis of vehicles.
- Suitable for all body shops and steel structures using steel THLE.
- Usable for any type of low temperature brazing to be carried out with special machines.
- The weld obtained is resistant to all types of corrosion, even without any type of protection applied.
- Is easily worked, the low melting temperature does not alter the characteristics of the base metal, it does not interfere with zinc plating.
- Packs of 5 kg, small coils.
- REGULATIONS: AWS A5.7; ER CuSi-A; EN14640; Scu6560 (CuSi3Mn1)

Code	Desc.	Ø filo mm	Weight Kg.
4020016900	13648	0,8	5
4020016910	13649	1,0	5

COMPOSIZIONE CHIMICA TIPICA %						
Cu	Si	Sn	Mn	Zn	Al	Pb
Base	3,0	0,8	1,0	/	/	/

NORMATIVE
AWS A5.7
ER CuSi-A
EN14640
Scu6560 (CuSi3Mn1)

**Caratteristiche meccaniche del riporto.**  
**Rm:** 350 Mpa  
**Rs:** 150 Mpa  
**A5d:** 42%

## Adapter for iron coils K300



- Adapter impact-resistant plastic for mounting of the coils in iron k300 on welding machines with pin diameter 50 mm.

Code	Description
4020002300	Adattatore per bobine

## Pressure reducing valves for technical gases: MIG / MAG / TIG



- Pressure reducers designed for combination with MIG / MAG / TIG and pulsed arc synergistic.
- Exceptional stability of supply.
- Equipped with a safety device.
- Available with flow meter Precision-argon / mixture and CO2.

Code	Desc.	Press. Ent. Bar	Press USC. Bar	Max Flow rate l/min.	Tipo di Gas
4020011500	12140	0 - 315	0 - 22	20	ARGON/MISCELA
4020011550	12100	0 - 315	0 - 22	20	CO2

## TIG torch 50 sq mm



- TIG torch complete with power cord from 50 sq mm.
- The use of this torch can weld "TIG smear" all metals, outside of aluminum and its alloys.
- Supplied as standard for the use of electrodes with a diameter of 2.4 mm.

Code	Desc.	Lunghezza cavo
4020014800	13300	4 m



## Come riconoscere il tipo di torcia delle saldatrici a filo

I NOSTRI RICAMBI PER TORCE DI SALDATRICI A FILO, SONO ADATTABILI SOLO AD UTENSILI COSTRUITI CON LO STANDARD "BINZEL", METODO DI COSTRUZIONE CHE RICOPRE ORMAI L'80-90% DELLA PRODUZIONE ATTUALMENTE IN COMMERCIO. E' BENE CONTROLLARE QUINDI CHE I PEZZI DI RICAMBIO SIANO UGUALI, SE NON MOLTO SIMILI, A QUELLI RAFFIGURATI NELLE NOSTRE FOTO.

I BECCUCCI GUIDA GAS AIUTANO - CON LE LORO DIMENSIONI - A RICONOSCERE LA GRANDEZZA E LA CORRENTE MASSIMA SOPPORTABILE DALLA TORCIA STESSA. IL CONTROLLO SI EFFETTUA MISURANDO CON UN CALIBRO IL DIAMETRO INTERNO DEL GUIDA GAS DAL LATO IN CUI ESSO VIENE INFILATO SULLA TORCIA, O COLLO DI CIGNO (Fig. 1).

LE TORCE DA 180 A MAX HANNO UN DIAMETRO INTERNO DI 12 mm

LE TORCE DA 250 A MAX HANNO UN DIAMETRO INTERNO DI 15 mm

LE TORCE DA 360 A MAX HANNO UN DIAMETRO INTERNO DI 20 mm OLTRE AD AVERE DEGLI INTAGLI SUL FONDO ED UNA FASCETTA IN ACCIAIO CHE STRINGE IL TUTTO (Vedere foto sul catalogo). GLI UGELLI GUIDAFILO (Fig. 2) SONO IDENTICI NELLE TORCE DA 250 E 360 A MAX. GLI UGELLI GUIDAFILO PER LE TORCE BZ 15 HANNO UNA FORMA LEGGERMENTE DIVERSA, E COMUNQUE POSSONO FUNZIONARE UGUALMENTE ANCHE CON ALTRI GUIDAFILO INSTALLATI. I DIFFUSORI GAS SONO INVECE TOTALMENTE DIVERSI PER OGNI TIPO DI TORCIA (Fig. 3) COME SI PUÒ' FACILMENTE VEDERE DALLE FOTO SUL CATALOGO. L'IMPORTANTE E' CHE SI SIA SICURI CHE TUTTE LE FILETTATURE DEGLI UGELLI SIANO M6 E NON M8 O DIVERSE ANCORA. L'ATTACCO DEL CAVO DELLA TORCIA E' DEL TIPO "EURO" E COME IL SISTEMA "BINZEL" E' COMPATIBILE CON L'80-90% DELLE SALDATRICI OGGI IN COMMERCIO.



## Torches Mig complete type Binzel



- Flashlights system Binzel, complete with cables and sheath of various lengths.
- Available for different welding powers.

TIPO TORCIA	CORRENTE MAX
BZ 15	180 A
BZ 25	250 A
BZ 36	360 A

Code	Desc.	Tipo torcia	Lunghezza cavo
4020010300	BZ15/3	BZ 15	3 m
4020010310	BZ15/4	BZ 15	4 m
4020010330	BZ25/3	BZ 25	3 m
4020010340	BZ25/4	BZ 25	4 m
4020010360	BZ36/3	BZ 36	3 m
4020010370	BZ36/4	BZ 36	4 m

## Spring for gas diffuser for torches 180 and 250A



- Spare parts for torches for welding wire tubes using system Binzel.
- Parts most subject to wear and replacement.

Code	Desc.	Ø molla	For torches
4020009300	15/M	12 mm	180 A
4020010000	25/M	15 mm	250 A

## Diffuser gas torches 180 A



- Spare parts for torches for welding wire tubes using system Binzel.
- Parts most subject to wear and replacement.

Code	Desc.
4020009310	15/D

## Diffuser gas torches 250 A



- Spare parts for torches for welding wire tubes using system Binzel.
- Parts most subject to wear and replacement.

Code	Desc.
4020010010	25/D

## Support tip M6 brass torches 360A



- Spare parts for torches for welding wire tubes using system Binzel.
- Parts most subject to wear and replacement.

Code	Desc.
4020010100	36/S

## Speaker insulating gas torches to 360A



- Spare parts for torches for welding wire tubes using system Binzel.
- Parts most subject to wear and replacement.

Code	Desc.
4020010110	36/D

## Contact tip M6 torches 180A



- Spare parts for torches for welding wire tubes using system Binzel.
- Parts most subject to wear and replacement.

Code	Desc.	Ø filo mm
4020009320	15/0.6	0.6
4020009330	15/0.8	0.8

## Contact tip M6 for torches 250 and 360A



- Spare parts for torches for welding wire tubes using system Binzel.
- Parts most subject to wear and replacement.

Code	Desc.	Ø filo mm
4020010020	25/0.8	0.8
4020010030	25/1	1
4020010130	36/1.2	1.2
4020010140	36/1.6	1.6

## Ugello guidafile M8 per torce da 250 e 360 A



- Spare parts for torches for welding wire tubes using system Binzel.
- Parts most subject to wear and replacement.

Code	Desc.	Ø filo mm
4020010195	M8-1.0	1,0
4020010200	M8-1.2	1,2
4020010205	M8-1.6	1,6

## Guidagas nozzle for torches 180 and 250A



- Spare parts for torches for welding wire tubes using system Binzel.
- Parts most subject to wear and replacement.

Code	Desc.	Diameter D int.	Ø d mm	For torches
4020009360	15/16	12 mm	16	180 A
4020009370	15/12	12 mm	12	180 A
4020010060	25/16	15 mm	16	250 A
4020010070	25/12	15 mm	12	250 A

## Guidagas nozzle for torches 360A



- Spare parts for torches for welding wire tubes using system Binzel.
- Parts most subject to wear and replacement.

Code	Desc.	Type
4020010170	36/19	UGELLO GUIDAGAS CILINDRICO Ø 19
4020010180	36/16	UGELLO GUIDAGAS CONICO Ø 16

## Replacement covers for torches MIG “Binzel”



- Wire hose isolated teflon type Binzel torches for welding wire.
- Ideal for welding wire of aluminum.
- Available in various lengths.
- Head stops sheath provided separately.

Code	Desc.	Length m	Ø filo
4020010460	3 - 0.6/0.8	3	0.6/0.8
4020010470	4 - 0.6/0.8	4	0.6/0.8
4020010480	5 - 0.6/0.8	5	0.6/0.8
4020010490	3 - 1/1.2	3	1/1.2
4020010500	4 - 1/1.2	4	1/1.2
4020010510	5 - 1/1.2	5	1/1.2
4020010520	3 - 1.2/1.6	3	1.2/1.6
4020010530	4 - 1.2/1.6	4	1.2/1.6
4020010540	5 - 1.2/1.6	5	1.2/1.6

## Teflon sheaths parts for MIG torches "Binzel"



- Wire hose isolated teflon type Binzel torches for welding wire.
- Ideal for welding wire of aluminum.
- Available in various lengths.
- Head stops sheath provided separately.

Code	Description	Length <i>m</i>	Ø int. x Ø est
4020010550	3T - 4	3	4x1.5
4020010560	4T - 4	4	4x1.5
4020010570	5T - 4	5	4x1.5
4020010580	6 - TE TESTINA PER GUAINA IN TEFLON Ø4	-	-



## Portable plasma cutting machine "Plasma 36"



- Portable electronic machine with built-in compressor plasma cutting of any metal. operation with single phase 220 volts, low power consumption, light weight.
- Ideal for fast and precise cutting of thick metal up to 10 mm. Can be used both in the workshop and on construction sites with motor generators by: body, transformations, machine shops, roadside assistance, road maintenance, blacksmiths, carpenters, builders fixtures, fitters, etc ..
- The machine automatically adjusts the ignition, the function for cutting grinded, full protection against overload. Low power consumption, built-in compressor inside. Clean cut with a thickness up to 10 mm., Separation cut up to 12 mm.
- Built according to the standards EN60974-1, 60974-7 and 60974-10. IP23 protection.

Code	Desc.
4020017430	PEC36

Technical Features	
Weight	16 Kg
Spessore di taglio su acciaio	10 mm
Dimensions	210 X 350 X 460 mm
Norme di costruzione	EN 60974-1 - EN 60974-7 - EN 60974-10
Protection rating	IP23
Fattore di servizio (EN 60974-1)	20%: 30A - 60%: 18A - 100%: 15A
Power supply	220 V - 50 Hz
Potenza assorbita	20%: 3,6 kWA - 60%: 2,1 kWA - 100%: 1,9 kWA
Cutting current	30 A
Separazione massima	12 mm

## Nozzle holder with 4 holes - Parts "Plasma Easy Cut 25, 26 and 36"



- Compatibili con torce PT-25C.

Code	Desc.
4020016580	13570

## Nozzle diameter 0.65 mm - Parts "Plasma Easy Cut 25, 26 and 36"



- Compatible with torches PT-25C.

Code	Desc.
4020016585	13571

## Electrode threaded M5 - Parts "Plasma Easy Cut 25, 26 and 36"



- Compatible with torches PT-25C.

Code	Desc.
4020016590	13572



## Diffuser insulation - Parts "Plasma Easy Cut 25, 26 and 36"



- Compatible with torches PT-25C.

Code	Desc.
4020016595	13573

## Nozzle holder - Parts inverter plasma cutting 35/P



- Ground Engaging parts for plasma cutting inverters Meccanocar 402 00 10900-35 / P.

Code	Desc.
4020013400	13220

## Diffuser insulation - Parts inverter plasma cutting 35 / P



- Ground Engaging parts for plasma cutting inverters Meccanocar 402 00 10900-35 / P.

Code	Desc.
4020013600	13240

## Protection nozzle holder - Parts inverter plasma cutting 35 / P



- Ground Engaging parts for plasma cutting inverters Meccanocar 402 00 10900-35 / P.

Code	Desc.
4020013800	13260

## Ø nozzle 0.8 mm - Parts inverter plasma cutting 35 / P



- Ground Engaging parts for plasma cutting inverters Meccanocar 402 00 10900-35 / P.

Code	Desc.
4020013500	13230

## Electrode - Parts inverter plasma cutting 35 / P



- Ground Engaging parts for plasma cutting inverters Meccanocar 402 00 10900-35 / P.

Code	Desc.
4020013700	13250

## Welding station at a controlled temperature



- Electronic welding station at a controlled temperature, with a soldering iron with a power of 40 W.
- Ideal for soldering and desoldering work on electronic cards and delicate and sensitive electronic components heat: electronics, audio / video repairs, control units of vehicles, repair and service centers, maintenance.
- Digital display of set temperature and the actual one, the adjustment range between 200 ° C and 450 ° C, sealing professional stylus with ceramic resistance and long life tip.
- Standard equipment: Electronic station, soldering iron 40 W, spring support and puff nettapunta.



Code	Desc.	W Watt	SupplyV/Hz	Weight gr.
4020016650	13637	40	220/50	1460

Spare Parts			
Article	Code	Description	
Spare tip Long Life for soldering iron	4020016660	13637/P	
Couple sponges for cleaning tip	4020016670	13637/S	

## Soldering irons for electronics



- Soldering irons of small and medium power for working on electronic circuit boards and electronic components also small.
- Suitable for machining of printed circuit boards and wiring flying: repair centers, maintenance, elettrauto, mechanical, electricians, aerial fitters, etc.
- The handle of insulating material is coated in non-slip material, the conformation allows support for the welder without danger of burning the support or the support surface, and in the head are mounted three LEDs with high brightness which illuminate the working area.
- Professional construction robust, stainless steel elements, heat insulated handles, steel bits long life for long life, size and weight very low.
- Current supply 220 volt 50 hz. Warm-up time of just 180 seconds.

Code	Desc.	Power W	Temperatura punta
4020016690	13638	25	400°C
4020016720	13639	40	482°C

Spare Parts			
Article	Code	Description	
Long Life tip for "13638" 25 W	4020016700	13638/P	
Long Life tip for "13639" 40 W	4020016730	13639/P	

## Soldering iron for electronic high power



- Saldatore a stilo per elettronica ad alta potenza, dotato di punta a scalpello larghezza 9,5 mm.
- Indicato per lavori di saldatura su componenti elettronici con elevata dissipazione di calore e di grandi dimensioni: centri di riparazione, manutentori, elettrauto, meccanici, installatori elettrici, antennisti, ecc.
- L'impugnatura in materiale isolante è rivestita in materiale antiscivolo, la conformazione permette di appoggiare il saldatore senza pericolo di bruciare il supporto o il piano di appoggio, ed in testa sono montati tre led ad alta luminosità che illuminano la zona di lavoro.
- Costruzione professionale robustissima, resistenza in acciaio inox, manico isolato dal calore, punta in acciaio long life per la massima durata, ingombro e peso ridottissimi.
- Alimentazione a corrente 220 volts 50 hz. Tempo di riscaldamento di soli 180 secondi.



Code	Desc.	Power W	Temperatura punta
4020016750	13640	80	482°C

Spare Parts			
Article	Code	Description	
Punta Long Life per "13640" 80 W	4020016760	13640/P	

## Instant gun soldering 100W



- Saldatore istantaneo a pistola professionale di grande potenza, per lavori gravosi quali: saldatura di pezzi di grandi dimensioni, taglio di materiale fusibile, sigillatura e pirografia.
- Utilizzabile praticamente in ogni settore: elettrauto, installatori, meccanica, autocarrozzeria, elettricisti, manutentori, antennisti, ecc.
- Elevata velocità di riscaldamento della punta di circa 7 secondi, peso e dimensioni contenute, luce d'illuminazione del punto di lavorazione, velocità e semplicità del cambio della punta. Alimentazione a corrente 220 volts 50 hz.
- Fornito di serie con punta per saldare, punta per tagliare e spianare, lega saldante universale.



Code	Desc.	W Watt	SupplyV/Hz	Weight gr.
4020016780	13641	100	220/50	1300

Spare Parts		
Article	Code	Description
Spare tip for welding (a)	4020016790	13641/P
Spare tip for smoothing (b)	4020016800	13641/T
Spare tip for cutting (c)	4020016805	13641/S

## Instant gun soldering 250W



- Instant gun soldering professional high power, suitable for heavy work such as welding and heating of large pieces, cutting of fusible material, sealing and pyrography.
- Can be used in virtually every industry: elettrauto, fitters, mechanics, bodywork, electricians, maintenance, aerial fitters, etc..
- High rate of heating of the tip of about 7 seconds, weight and dimensions, illumination light of the machining point, speed and simplicity of changing the tip. Current supply 220 volt 50 hz.
- It comes with steel toe plated long life with very long life.

Code	Desc.	W Watt	SupplyV/Hz	Weight gr.
4020016810	13642	250	220/50	1830

Spare Parts		
Article	Code	Description
Spare tip Steel Long Life (a)	4020016820	13642/P
Spare tip for cutting (b)	4020016825	13642/T

## Welders hammer Eavy Duty



- Welders hammer with copper bat for heavy work of welding or heating of large pieces.
- Used in plumbing, bodywork, electrical and hydraulic systems, etc.
- Professional construction with armored elements in stainless steel, monolithic tips corrosion tinned copper, insulated handle the heat. AC operation 220 Volts, 50 Hz neoprene cable highly flexible.

Code	Desc.	W Watt	SupplyV/Hz	Weight gr.
4020017240	13729	100	430°C	450
4020017250	13730	180	460°C	620
4020017260	13731	250	480°C	850

Spare Parts		
Article	Code	Description
Copper tip 100 W	4020017270	13729R
Copper tip 180 W	4020017280	13730R
Copper tip 250 W	4020017290	13731R

## Handheld gas welder



- Refillable butane-gas welder and heater for welding, cutting and heating electrical and electronic parts as well as parts in plastic or wood (pyrography).
- Useful for working in any site without the need for wires or electricity. Piezoelectric ignition.
- Compact size and extremely easy refill. A canister of lighter gas (our code no. 4020016890) make this a unique, essential tool for welding, braze welding, tightening connectors and sheaths, carving wood, cutting plastics for the electrical and electronic industries, vehicle electronics, etc.
- Naked flame temperature: 1300°C. Maximum tip temperature; 450°C. temperature adjustment.
- Supplied in plastic case. Equipment: hot air nozzle, 1 mm bit, 2.4 mm diameter bit, blade tip, bit cleaner, chuck for bit replacement, package of solder for electronics. Welder weight: 468 grams

Code	Desc.
4020017460	WP3U

## Butane gas for welders and portable lighters



- Butane gas cylinder for charging portable welders, lighters and lighters of all kinds.
- It equipped with a complete set of adapters for each valve.

Code	Desc.	Content ml
4020016890	13647	200



## Butane gas welding torch



- 1 Bruciatore a fiamma appuntita
- 2 Bruciatore standard
- 3 Bruciatore a fiamma avvolgente
- 4 Bruciatore ad aria calda
- 5 Bruciatore a fiamma dolce

- Torch light and well balanced with piezoelectric ignition push-button operation with tank mixture of propane-butane.
- Ideal for welding, heating, stripping, etc .. in any field of work, such as: mechanical, plumbing and heating and plumbing, electricity', construction vehicles, etc.
- Simple and precise flame adjustment with lock for continuous. Full support for keeping standing the burner.
- The equipment includes a burner flame pointed for precision work (cod. 443 00 45212) and a standard burner for soft soldering (cod. 443 004 5213).
- Accessories: burner flame enveloping soft soldering and brazing tubes (cod. 443 00 45214), burner hot air for removing paint and termoretract (cod.443 00 45215), the burner on low heat for particularly challenging (cod. 443 00 45216).

### CARATTERISTICHE TECNICHE DEI BRUCIATORI

Articolo	Modello / foto	Consumo gas g/h	Temperatura °C	Effetto calorico kW	Ø bruciatore mm
551/1	Fiamma appuntita/1	30	500	400	15
551/2	Standard/2	70	700	900	16
551/3	Fiamma avvolgente/3	80	800	2150	14
551/4	Aria calda/4	85	900	1000	38
551/5	Fiamma dolce/5	130	700	3500	23

Code	Desc.	Article	Photo
4430045210	551	Torch complete with standard burner flame and sharp (551 / 1-551 / 2)	/
4430045211	551/B	Cylinder parts 600 ml - 330 g.	/
4430045212	551/1	Flame burner pointed	1
4430045213	551/2	Standard burner	2
4430045214	551/3	Burner flame enveloping	3
4430045215	551/4	Burner hot air	4
4430045216	551/5	Burner on low heat	5

## Sucks pond manual



- Sucks pond manual tipped Teflon antistatic.
- Suitable for all desoldering operations on electronic circuits.

Code	Desc.	Model
4430049845	969	Sucks pond
4430049850	969/R	Spare tip

## Tin wire for electronics



- Wire tin solder core pickling in rosin, ideal for use in the electrical and electronic fields.
- Available in convenient reels.
- Percentage tin / lead: 60/40.

Code	Desc.	Ø mm	Weight gr.
4020000100	4/2	2,0	500
4020016870	13645	1,5	250
4020016880	13646	1,0	100

## Tin Rods for welding

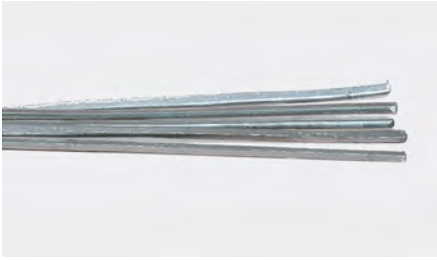

- Rods of tin / lead for use in electromechanical.
- Ideal for welding of pipes and plates.

Code	Desc.	Length <i>mm</i>	Conf. Kg	N. <i>Pieces</i>	Sn/Pb
4020000150	4/35	450	2	14	35/65
4020000160	4/50	450	1	6	50/50

## Automatic electronic spotter

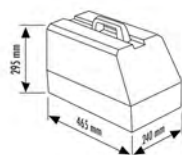

- Spotter electronic synergistic inverters, fully automatic and easy to use for each type of steel sheet. The machine is adjusted alone during welding according to the type of sheet, the thickness and the conductivity of the metal.
- Suitable for all straightening operations of sheet metal and profiles / molded in the body shop. Spot welding of all types of accessories for the draw, heating function and swaging.
- Automatic triggering of the welding current, single-phase current 220 Volts operation, low power consumption and easy portability.
- Equipped with double cable series, mass and gun, flashlight with universal connection for accessories, swing hammer electrode for tack and hot.

Code	Desc.
4020017470	610SG

Tecnical Features	
Dimensions	225X360X235 mm
Weight	24 Kg
Lunghezza/sezione cavo massa	2 m / 70 mmq
Lunghezza/sezione cavo torcia	2 m / 70 mmq
Termostato di sicurezza sui connettori	70°C max
Tensione secondaria	7,5 Volts
Fusibili ritardati di protezione	16 A
Power supply	220 Volts - 50/60 Hz
Secondary current maximum welding	2800 KA
Short circuit secondary current	3500 KA

## Automatic electronic spotter for aluminum



- Digital inverter electronic spotter for laminates and aluminum profiles, with great power and easy and intuitive adjustments of great precision.
- Suitable for all straightening operations of sheet metal and profiles / molded in the body shop. Spot welding of all types of accessories for the draw made in aluminum / silicon alloys and aluminum / magnesium.
- Automatic triggering of the welding current without trigger on the torch, it triggers with the push of the hand. Single-phase current 220 Volts operation, low power consumption and easy portability.
- Electronic control with 9 power preset menus that allow you to adapt the sealing temperature to any situation without burning the material.
- The mass of the machine is directly formed on the handle of the score counter, no need to discover painted areas for its application.
- Equipped with a dual-function special cable series for gun, flashlight with universal connection for accessories.

Code	Desc.
4020017050	ASPS230

Tecnical Features	
Weight	14 Kg
Dimensions	210X360X240 mm
Lunghezza/sezione cavo torcia	3 m / 25 mmq
Capacitor discharge capacity	53 millifarad
Termostato di sicurezza sui connettori	70°C max
Fusibili ritardati di protezione	5 A
Power supply	220 Volts - 50/60 Hz

### 3-prong washer



- The replacement of the tip of use using the rotation of the washer allows to increase the useful life.
- In copper-plated steel.

Code	Desc.	Ø hole mm	S mm	H mm	B mm
4020016100	13340	10	2	50	5

### Electrode 3 tips washer



- Electrode 3 tips washer.

Code	Desc.	H mm	L mm	Ø d mm
4020016350	13390	60	3	13

### Washer slotted straight

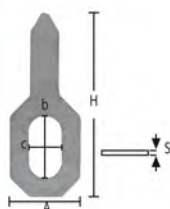

- The use of slotted washers allows the execution of a draw in multiple points of attachment.
- In copper-plated steel.

Code	Desc.	Foro b x c	S mm	H mm	A mm
4020016150	13350	19x10	1,5	57	22

### Electrode slotted washer



- Electrode slotted washer.

Code	Desc.	H mm	A mm	Ø d mm
4020016400	13400	71	24	10

### Copper plug



- Nail for the pulling of the bodywork.
- In copper-plated steel.

Code	Desc. Ø x L
4020016000	13320-2x50 mm

### Electrode copper plug



- electrode for copper plug 2 x 50 mm.

Code	Desc.	A mm	L mm	Ø d mm	Ø D mm
4020016200	13360	16	50	3	4

## Wavy wires

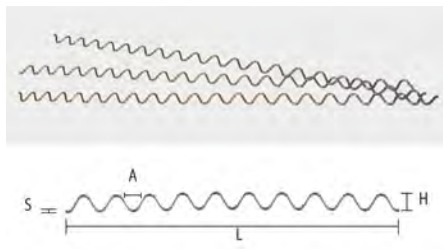

- Suitable for simultaneous draw in multiple points.
- In copper-plated steel.

Code	Desc.	L mm	A mm	H mm	S mm
4020016050	13330	345	16	10	2

## Electrode for wavy wire

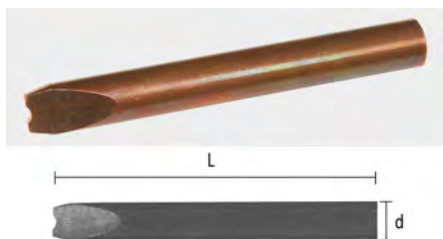

- Special electrode to wiggly wires.

Code	Desc.	Ø d mm	L mm
4020016250	13370	10	80

## Support for wavy wire

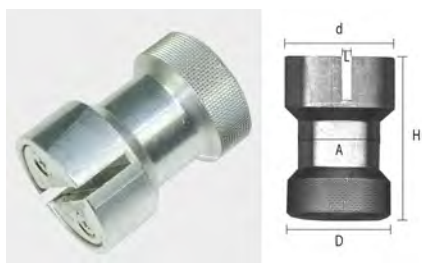

- Special magnetic support for wavy wire.

Code	Desc.	H mm	Ø d mm	Ø D mm	Ø A mm	L mm
4020016300	13380	42	30	28	22	3,5

## Threaded studs for aluminum / silicon



- Threaded studs for the pulling of metal sheets and profiles or parts box-aluminum-silicon alloy (Al-Si). Usable with all spotter machines for aluminum on the market.
- Indicated for use in all the bodies for the repair of vehicles and all light alloy parts used in the transformations: tarpaulin, lorries and refrigerator installations, banks, etc.
- Dimensions: Thread M4 X 15 mm. Usable with our threaded slotted washers 402 00 17080-13718 Code steel.

Code	Desc.	Dimensions mm
4020017060	13716	M4 X 15

## Threaded studs for aluminum / magnesium



- Threaded studs for the pulling of metal sheets and profiles or parts box-aluminum-silicon alloy (Al-Si). Usable with all spotter machines for aluminum on the market.
- Indicated for use in all the bodies for the repair of vehicles and all light alloy parts used in the transformations: tarpaulin, lorries and refrigerator installations, banks, etc.
- Dimensions: Thread M4 X 15 mm. Usable with our threaded slotted washers 402 00 17080-13718 Code steel.

Code	Desc.	Dimensions mm
4020017070	13717	M4 X 15



## Slotted washers for M4 studs



- Threaded steel eyebolts for the pulling of the sheets in conjunction with our studs of aluminum alloys, codes 402 00 and 402 00 17060-13716 17070-13717.
- Indicated for use in all the bodies for the repair of vehicles and all light alloy parts used in the transformations: tarpaulin, lorries and refrigerator installations, banks, etc.
- Dimensions: M4 thread.

Code	Desc.	Dimensions <i>mm</i>
4020017080	13718	M4

## Splash protection Soldering



- For carpentry, blacksmithing.
- Anti-adhesive liquid that prevents the fusion of weld spatter on the surface around the area to be welded.
- If sprayed on the nozzles of welding, it prevents seizure.
- It does not contain silicone or products that prevent the adhesion of paints, galvanizing, etc..
- Create an anticorrosive film, as long as the product is not removed.
- To be used preferably with our regulator pressure Meccanocar code: 4110001205.

Code	Desc.	Cont. Lt
4110017060	4195	5

## anti-slag pasta



### CHARACTERISTICS

- Anti-slag pasta based soldering of pure greases in aqueous solution, completely free of silicones and chlorinated.
- It prevents the adhesion of weld spatter in spouts of electric welders.
- Product absolutely nonflammable, vapor almost nonexistent, odorless.

### HOW TO USE

- Directly immerse the tip of the welding gun, hot, in the product, which will settle forming a protective film on the outside and the inside of the spout.
- **Suitable for all types of torches jumpers in wire and process tig.**

Code	Desc.	Content gr.	Color
4110015230	2874	300	GREEN

## Pastasalda



- E' un disossidante per saldature a stagno.
- Va applicata una piccola quantità di prodotto sulle parti da unire per saldatura.
- Evita l'ossidazione e la formazione di scaglie dal processo di saldatura eseguito con stagno a filo, favorendo la perfetta esecuzione.
- Prodotto adatto in ogni campo di applicazione: elettrica, meccanica, idraulica, ecc.

### APPLICAZIONE:

- Scaldare leggermente le parti da unire, stendere su di esse un po' di pastasalda indi applicare lo stagno.

Code	Desc.	Content gr.
4110009000	2675	75

## Splash protection water based for welding



- **CHARACTERISTICS:**
- Not inflammable product water-based protection from weld spatter of welding nozzles and weldments.
- Forms a very thin film and transparent that prevents seizure of the droplets of solder on any media or corrosion by chemical agents.
- Thixotropic product, sprayed from a suitable distance, not drip even when applied to vertical surfaces.
- The product is free of silicones, which allows any subsequent processing such as painting, galvanizing, etc.. no problem.
- **HOW TO USE:**
- Spray the product from a distance of about 20 cm. on the part to be treated, metal, nozzles, spouts, etc.
- **CAUTION:** Spray the product only on the points where you should not be welded. Free up the tract that affects the weld.

Code	Desc.	Content ml
4110015235	2875	400

## Splash protection solder non-silicone



- It protects surfaces from weld spatter.
- It prevents weld spatter (splinters) to pause on the nozzles of welding.
- It forms a thin film that protects the treated parts by the formation of oxide.
- It decreases the effect of blooming that is created when you operate welding stainless steel.
- Does not contain silicone, it allows for the immediate treatment of the surface welded during painting or galvanizing.
- Allow to dry before processing.

Code	Desc.	Content ml
4110014660	2744	400

## Flame protection glasses



- Sunglasses classic plastic soft green with round lenses with protection DIN 5.
- Built in accordance with EN 166.
- Available replacement lenses  $\varnothing$  50 mm.

Code	Desc.	Model
4020004000	1104280	Glasses complete
4020006900	1104462	Couple lens replacement

## Protective glasses for grinding / welding



- Glasses with clear lenses and protective lenses folding fixed.
- Highly practical for welding and grinding operations simultaneously, protection of green DIN 5 lenses, oxy-gas cutting and welding.
- Mask equipped with valves ventilation to prevent fogging.
- Built in accordance with EN 166.

Code	Desc.	Model
4020004020	1104298	Protection glasses
4020004100	1104454	Couple transparent protective lenses
4020006900	1104462	Couple protective lenses DIN 5

## Glass parts for welding masks



- Protective glasses for welders' masks with window size 75x98 mm in accordance with DIN.
- Transparent and available for protection adiacinic varying degrees DIN.

Code	Desc.	Color	Degrees DIN
4020002500	307	Transparent	- - - -
4020002600	026	Adiacinic	11
4020002605	026S	Mirrored	12
4020002607	027S	Mirrored	13

### Mask by hand for welding



- Welding shield, curved model with anatomic grip plastic.
- Construction cellulose fiber glare riveted with quick glass of protection.
- Window size 75x98 mm in accordance with DIN.
- Supplied without glass.
- Complies with CE and EN 175.

Code	Desc.
4020003000	903

### Welding helmet for welding



- Protective helmet for welding polypropylene, designed to offer maximum protection in the solder that you can not stand the classical mask with your hands.
- Quick fixing of the protective glass, adjustable headrest for the best comfort at work.
- Window size 75x98 mm in accordance with DIN.
- Supplied without glass.
- Complies with CE standards.

Code	Desc.
4020003010	904

### Welding mask automatic darkening



- Exclusive mask optoelectronics with cell patented automatic darkening with unique degree of 11 DIN.
- Cell block inviolable and fully waterproof and shock resistant.
- Perfectly impervious to fluids, to welding fumes, dust and sweat.
- Protection level at rest DIN 3, darkening to DIN 11 in time of 0.5 milliseconds.
- Maximum freedom 'of movement even in very challenging work.
- Complies with DIN - EC, EN 166-379.

Code	Desc.	Model
4020015100	13311	Optoelectronics mask
4020002610	090	Protective glass 90x110 mm outer
4020002620	091	Protective glass 46x110 mm internal



## Darkening welding mask for automatic adjustment



- Exclusive mask optoelectronics with cell patented automatic darkening degree adjustable with continuity 'from 9 to 13 DIN.
- Cell block inviolable and fully waterproof and shock resistant.
- Perfectly impervious to fluids, to welding fumes, dust and sweat.
- Protection level at rest DIN 3, darkening over time of 0.5 milliseconds adjustable from outside via potentiometer.
- Maximum freedom 'of movement even in very challenging work.
- Complies with DIN - EC, EN 166-379

Code	Desc.	Model
4020015000	13310	Optoelectronics adjustable mask
4020002610	090	Protective glass 90x110 mm outer
4020002620	091	Protective glass 46x110 mm internal

## Apron crust for welders



- Smock completely crust for welders, CE mark.
- Format 60x90 cm / C.

Code	Desc.
4720008200	193

## Gloves in crust for welders



- Glove crust full of seam-fully lined inside with cotton fabric.
- It allows to handle with dexterity tools for welding.
- According to the EC, category 2.

Code	Desc.
4460007400	4017

## Gaiters crust for welders



- Protective gaiters totally crust for welders.
- Velcro straps, which greatly simplifies the operations of the shoe.
- In conformity with EN 470.

Code	Desc.
4460008895	4221

## Protection blanket sparks



- Spark-proof blanket / fireproof.
- Produced in glass fiber, it ensures total protection during the grinding operations and appuntatura in the workshop and bodywork.
- 2x1 m size.

Code	Desc.	Formato m
4770001830	183	2 x 1