

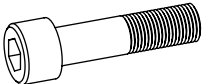



FI	Concept vaunu	DE	Concept Wagen
SV	Concept vagn	FR	Desserte mobile Concept
EN	Concept trolley		

	M8x60	8
	5x20	4
	M10x25	4
	Ø10	4
	M10	4





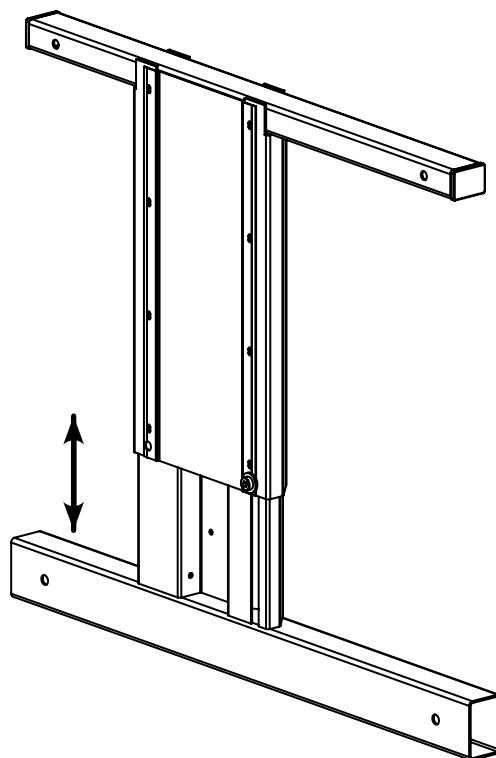
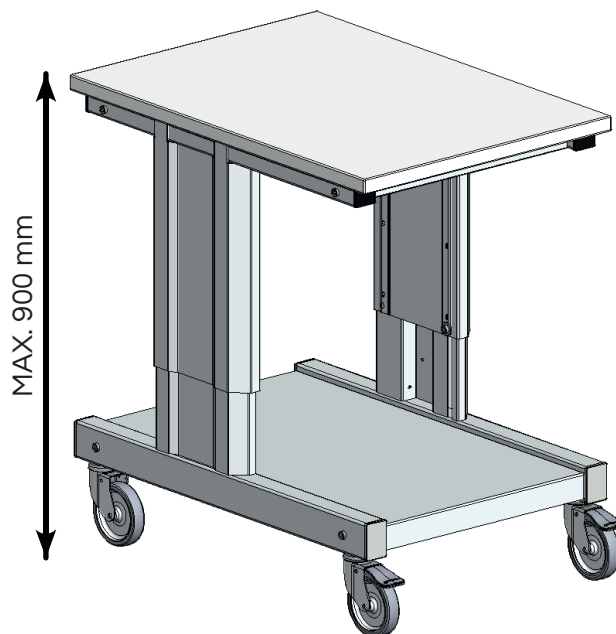
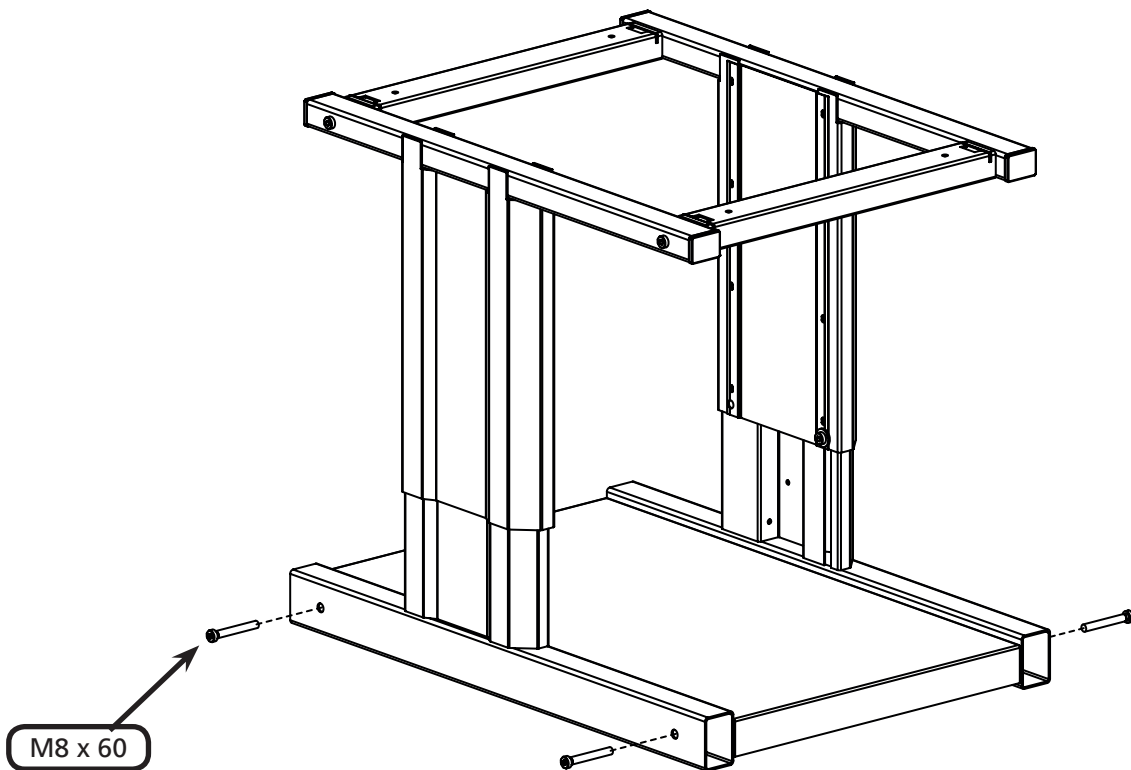
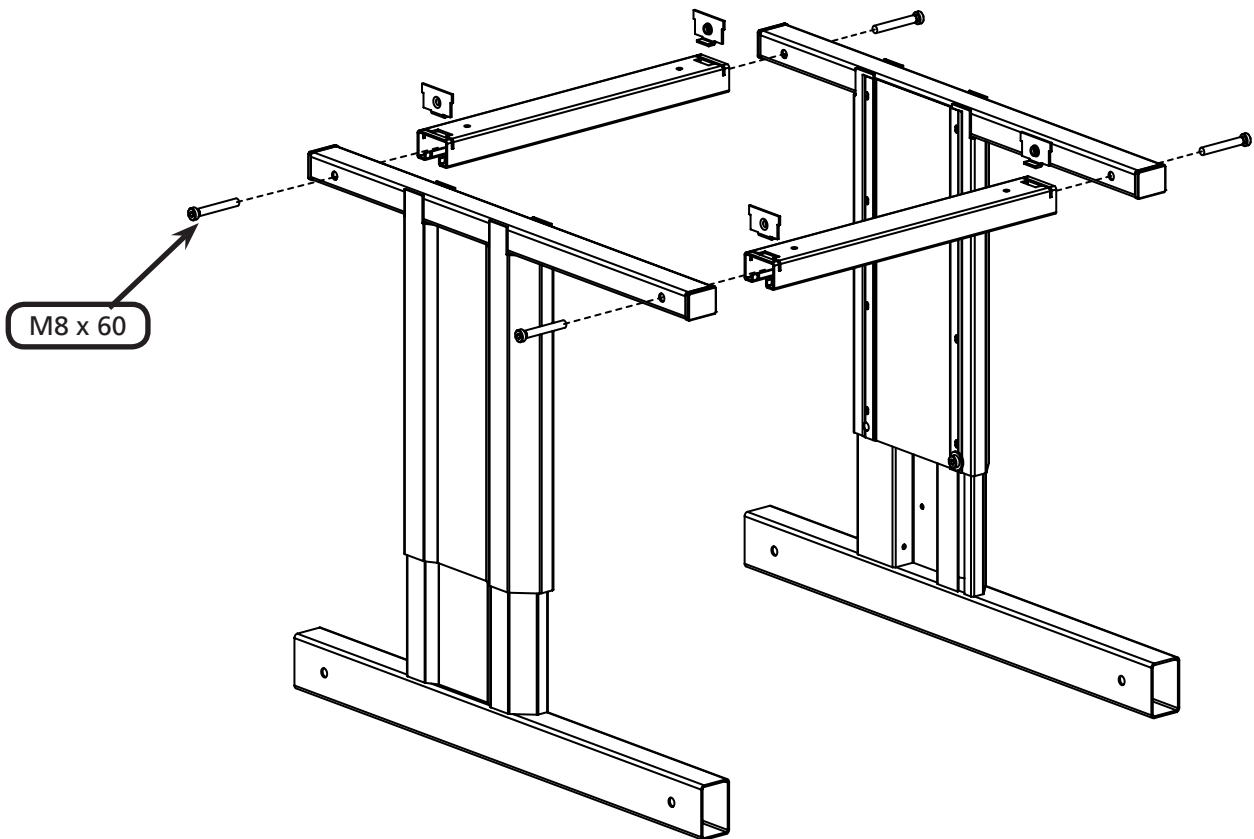
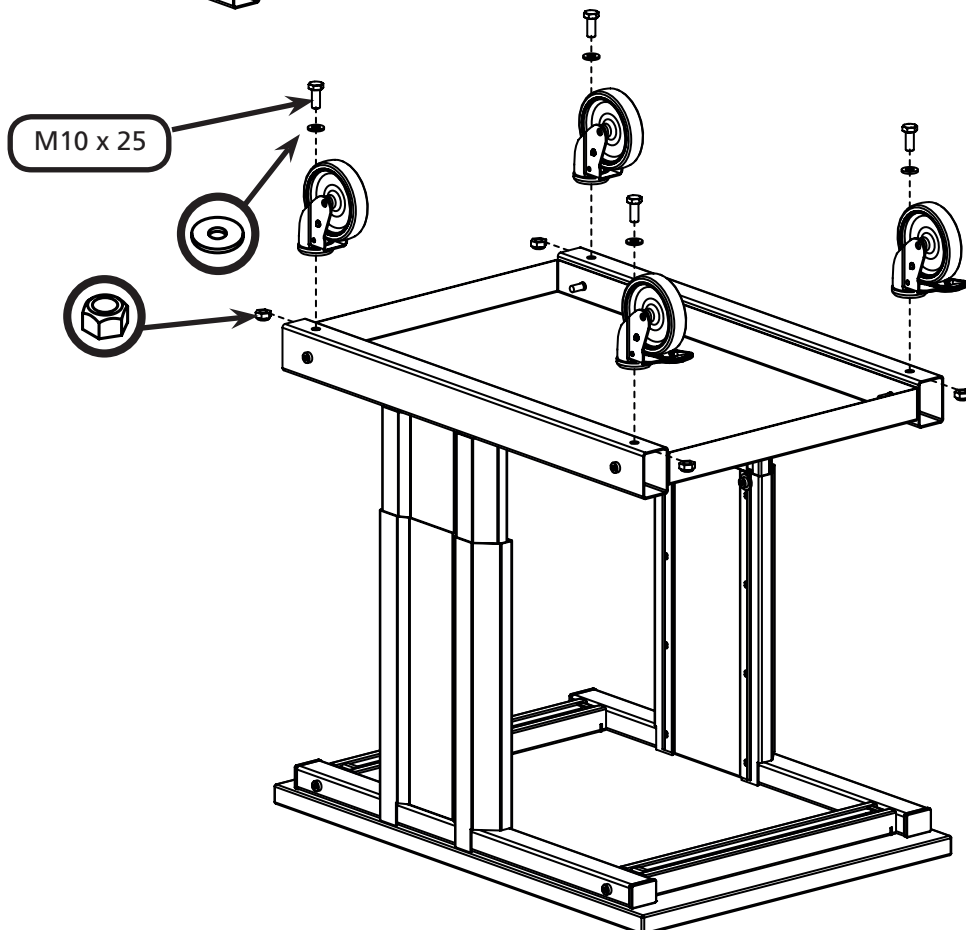
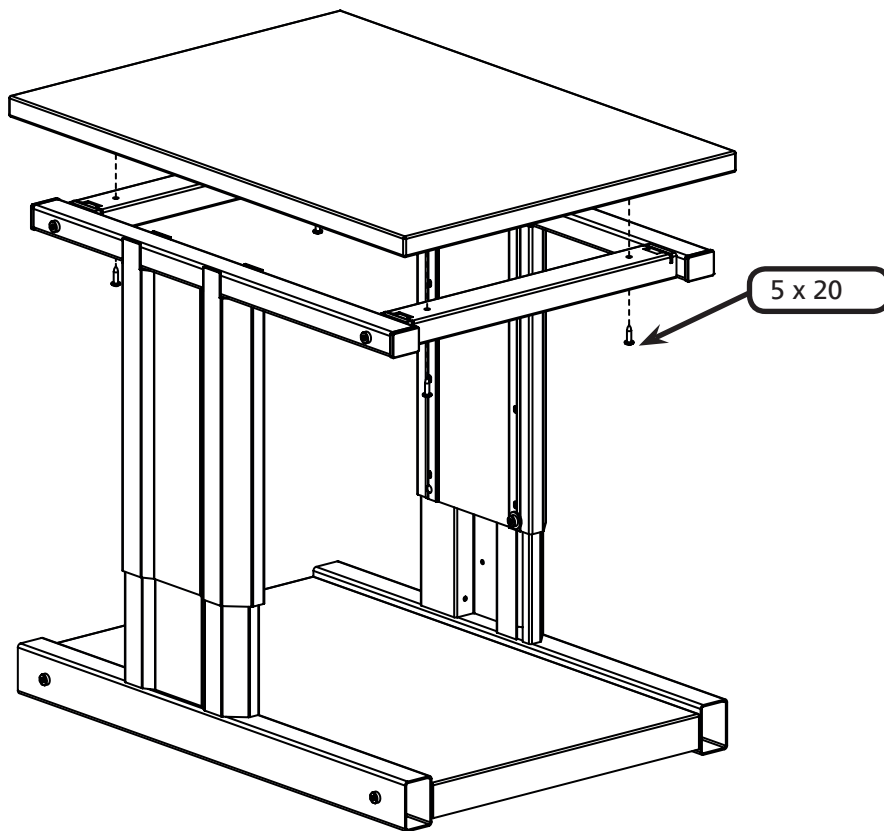

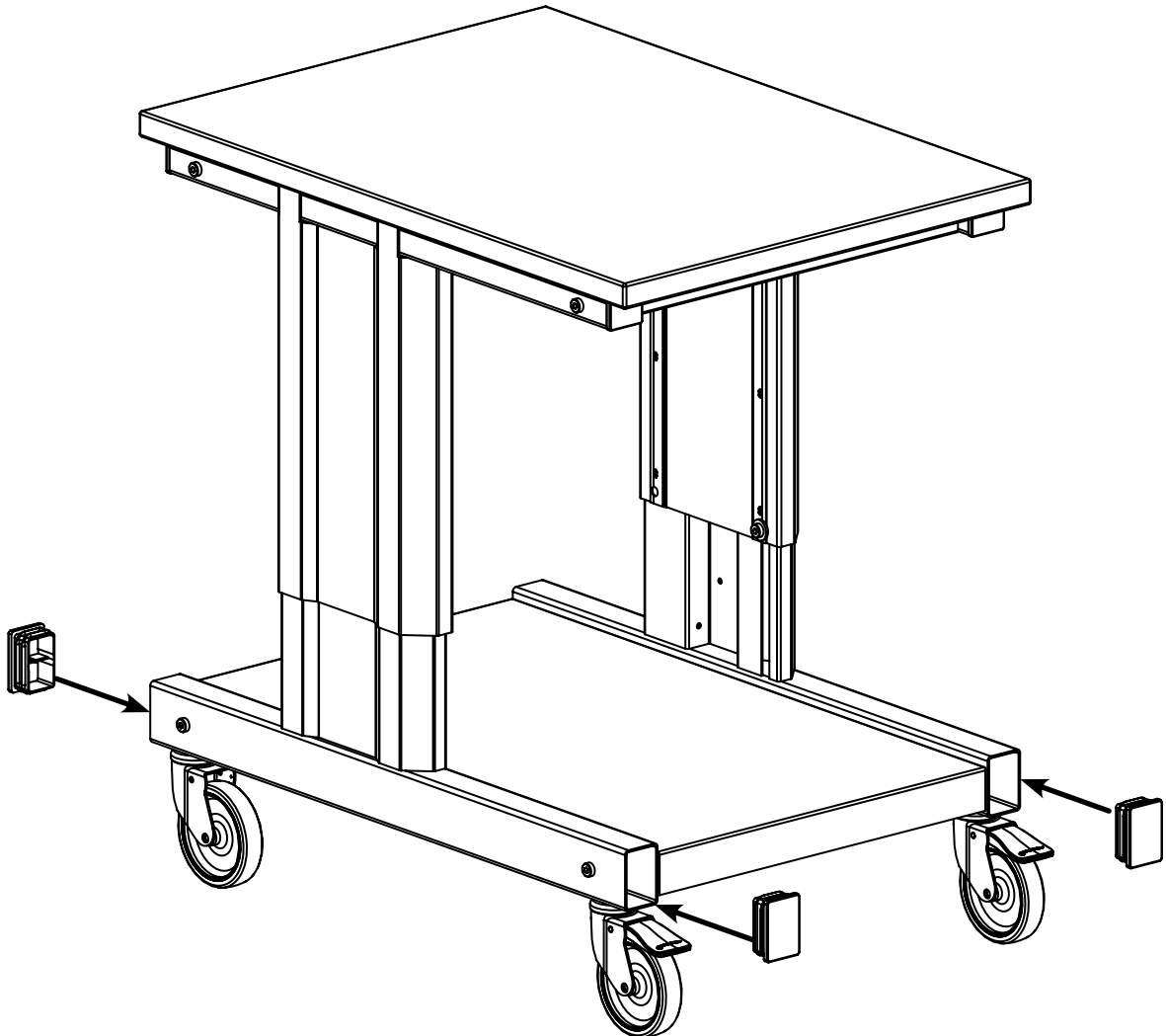

PHENOLIC

DO NOT USE provided screws from the hardware pack provided with the table. These screws are for laminate work surfaces only.

Phenolic tops can be assembled in 2 ways:

Mechanical fasteners - Screws to be provided by the installer. Pre-drill a pilot hole in the bottom of the work surface, taking care to keep from penetrating through the top. The pre-drilled hole should be the same length as the screw shaft. The screw should be slightly larger in diameter than the pilot hole. Use a coarse threaded screw, wood or machine.

Adhesive - Provided by the installer. Use 100% silicon. Apply several "spots" or a continuous bead to the top of the table frame. Position the work surface as centered on the frame and let cure for 12 hours at room temp.