

മികവ്

പഠന സഹായി

ഹയർ സെക്കണ്ടറി

ഉറുർജ്ജതന്ത്രം



ജില്ലാ പഞ്ചായത്ത്, കാസർഗോഡ്

2013-14

മിതവ് 2014

Advisory Committee

- Chairman** : **Adv. P.P. Syamala Devi**
President, District Panchayath, Kasaragod.
- Vice Chairman** : **Smt. K. Sujatha**
Standing Committee Chairman for Education & Health,
District Panchayath, Kasaragod.
- Convenors** : **Sri. Srikrishna Kayarthaya**, DDE, Kasaragod
Dr. P.V. Krishna Kumar, Principal, DIET, Kasaragod.
Smt. Vijayalakshmi H.S, DPO, SSA, Kasaragod.
- Members** : **Sri. I. Sathyanarayana Bhat**, DEO Kasaragod.
Sri. Mohanan, DEO, Kanhangad.
Sri. K. Kamalakshan, Sr. Lecturer, DIET, Kasaragod.
- Academic Support** : **DIET Kasaragod.**

ADV. P.P. SYAMALA DEVI
President
District Panchayath
Kasaragod
Ph: 04994 - 256277
Fax: 256277



‘Athira’
Nelkkala Road
Vidyanagar
Kasaragod - 671 123
Ph: 04994 - 220926
04994 - 230791
Mob: 9495653810

Date: 28.10.2013

മുഖമൊഴി

ഗുണനിലവാരമുള്ള വിദ്യാഭ്യാസം ഓരോ കുട്ടിയുടെയും അവകാശമാണ്. അത് ഉറപ്പു വരുത്തുക എന്നത് നമ്മുടെ കർത്തവ്യമാണ്. വിദ്യാർത്ഥികളുടെ പഠനനിലവാരം മികവുറ്റതാക്കുവാനുള്ള യത്നങ്ങൾ എല്ലാ സ്കൂളുകളിലും നടപ്പിലാക്കി വരുന്നത് ഏറെ സന്തോഷകരമാണ്. ഹയർ സെക്കണ്ടറി വിദ്യാർത്ഥികളുടെ പഠനനിലവാരം ഉയർത്തുവാൻ കാസറഗോഡ് ജില്ലാ പഞ്ചായത്തിന്റെ നേതൃത്വത്തിൽ നടപ്പിലാക്കിവരുന്ന മികവ് പദ്ധതി ജില്ലയിലെ ഹയർ സെക്കണ്ടറി വിജയശതമാനം ഗണ്യമായ രീതിയിൽ ഉയർത്തുവാനും ജില്ലയുടെ വിദ്യാഭ്യാസ പിന്നോക്കാവസ്ഥ ഒരു പരിധിവരെ പരിഹരിക്കുവാനും സഹായിച്ചിട്ടുണ്ട്. ഹയർ സെക്കണ്ടറി പരീക്ഷയ്ക്കുള്ള മുന്നൊരുക്ക പ്രവർത്തനങ്ങൾ എല്ലാ സ്കൂളുകളിലും നടന്നുവരുന്ന ഈ സന്ദർഭത്തിൽ കുട്ടികളിൽ ആശയങ്ങൾ കൂടുതൽ ദൃഢീകരിക്കാൻ ഉതകുന്ന, അധ്യാപകർക്ക് സഹായകമായ ഒരു കൈപുസ്തകം ‘**മികവ് 2014**’ കാസറഗോഡ് ജില്ലാ പഞ്ചായത്ത് ഈ വർഷവും പുറത്തിറക്കുകയാണ്. ചോദ്യങ്ങൾ, ചർച്ചകൾ, ചെറു ഗ്രൂപ്പ് പ്രവർത്തനങ്ങൾ തുടങ്ങിയവയിലൂടെ ഇത് സാധിക്കുമെന്നു ഞങ്ങൾ വിശ്വസിക്കുന്നു. താഴ്ന്ന നിലവാരമുള്ള കുട്ടികൾക്കും ഉയർന്ന നിലവാരമുള്ള കുട്ടികൾക്കും ഒരു പോലെ ഗുണകരമാകുന്ന വ്യത്യസ്ത നിലവാരത്തിലുള്ള പഠന പ്രവർത്തനങ്ങൾ ഇതിൽ ഉൾപ്പെടുത്താൻ ഞങ്ങൾ ശ്രദ്ധിച്ചിട്ടുണ്ട്. ഈ വർഷം ജില്ലയിലെ മുഴുവൻ കുട്ടികളെയും C+ നു മുകളിലുള്ള ഗ്രേഡുകളിലേക്ക് ഉയർത്തുക എന്ന നമ്മുടെ ലക്ഷ്യം സാക്ഷാത്കരിക്കാൻ ഇത് സഹായകമാകുമെന്ന് ഞങ്ങൾ പ്രത്യാശിക്കുന്നു. അതിനായി ജില്ലയിലെ മുഴുവൻ പ്രധാന അധ്യാപകരുടെയും, അധ്യാപകരുടെയും, കുട്ടികളുടെയും, രക്ഷിതാക്കളുടെയും നാട്ടുകാരുടെയും ആത്മാർത്ഥമായ സഹകരണവും പിന്തുണയും പ്രതീക്ഷിച്ചുകൊണ്ട്,

പ്രസിഡണ്ട്

ജില്ലാ പഞ്ചായത്ത്, കാസറഗോഡ്.

ഉള്ളടക്കം

1. ഉൾജ്ജതനം

5 - 148

Resource Team :

- 1) **M. Balagopalan, HSST**
Chattanchal HSS
- 2) **M. Gangadharan , HSST**
HHSIBHSS Edneer
- 3) **N. Venunathan, HSST**
Durga HSS Kanhangad

HIGHER SECONDARY

PHYSICS

Chapter 1

ELECTROSTATICS

Electrostatics : study of electric charges at rest.

Experiment : A glass rod rubbed with silk shows the property to attract small object such as bits of paper- why-They posses electric charges.

- What is the Process - Electricfication - The process of a cquiring electirc charges by friction (rubbing)
- Can all the bodies charged by friction - No- only insulators.
If the material is conductor(Eg:- Cu), any charge produced on it by friction can easily get discharged to earth.
- The electrostatic experiment should be performed in dry air or climate -why? If the air is moist it is slightly conducting the electric charges get discharged to earth.
- Can electric charges be created during rubbing - No- only transfer of charges from one body to other takes place - The body which looses electrons becomes +ve charged and that which gains electrons became -ve charged.
- In the above experiment which is +ve and which is -ve? Glassrod is +ve while silk is -ve
- Is there any there transfer of mass -yes, Electron has finite mass.

What are the properties of electric charge

1) Quantization Property

Total Charge of a body $Q = \pm ne$

n - an integer, $e = 1.6 \times 10^{-19}$ C, charge of electron

- Find no. of electrons in charge IC

$$\begin{aligned} \text{No of electrons } n &= \frac{IC}{1.6 \times 10^{-19}} \\ &= 6.25 \times 10^{18} \end{aligned}$$

2) Conservative Property - Total charge remains constant

- What is coulombus inverse sqaure law in electrostatics

Electrostatic force (F) between two electric charges q_1 and q_2 seperated by a distance r in a medium

$$F \propto \frac{q_1 q_2}{r^2}$$

$$F = \frac{1}{4\pi\epsilon} \frac{q_1 q_2}{r^2}$$

Where ϵ = absolute permituvityof the medium.

If the medium is air or free space

$$F = \frac{1}{4\pi\epsilon_0} \frac{q_1 q_2}{r^2}$$

where $\epsilon_0 = 8.85 \times 10^{-12} \text{ C}^2\text{N}^{-1}\text{m}^{-2}$, Permittivity of air

What is the relation between ϵ and ϵ_0

Relative permittivity of a medium $\epsilon_r = \frac{\epsilon}{\epsilon_0}$, it is dielectric constant. For air $\epsilon_r = 1$.

- Electric force between two charges in a medium of relative permittivity ϵ_r is $F = \frac{1}{4\pi\epsilon_0\epsilon_r} \frac{q_1 q_2}{r^2}$
- What is the new force between two charges, when magnitude of the charges doubled and distance between them halved.

$$F = \frac{1}{4\pi\epsilon_0\epsilon_r} \frac{q_1 q_2}{r^2}$$

$$F^1 = \frac{1}{4\pi\epsilon_0\epsilon_r} \frac{2q_1 2q_2}{\left(\frac{r}{2}\right)^2}$$

$$\therefore \frac{F^1}{F} = 16, \text{ Hence } F^1 = 16F$$

- Comparison of Electric force between two electric charges in a medium to air.

$$F_{\text{medium}} = \frac{1}{4\pi\epsilon_0\epsilon_r} \frac{q_1 q_2}{r^2}$$

$$F_{\text{air}} = \frac{1}{4\pi\epsilon_0} \frac{q_1 q_2}{r^2}$$

$$\frac{F_{\text{medium}}}{F_{\text{air}}} = \frac{1}{\epsilon_r}$$

$$\therefore F_{\text{medium}} = \frac{F_{\text{air}}}{\epsilon_r}$$

ϵ_r always greater than one. $\therefore F_{\text{medium}} < F_{\text{air}}$

- Two point charges q_1 and q_2 such that $q_1 + q_2 = 0$ what is the nature of force between them?
If $q_1 + q_2 = 0$ $q_1 = -q_2$ Attractive nature since charges are of opposite signs
- Unit of electric charge - coulomb (C)
 $1\text{C} = 6.25 \times 10^{18}$ electronic charge.

What is Electric Field

- The vector representation of Electric field.
- Space around an electric charge where electric force of attraction or repulsion is felt.
- What is the intensity of electric field? It is the electric force per unit charge.
 $E = \frac{F}{q}$
- Force experienced by unit charge
 \therefore Electric force = Electric field Intensity x charge
 $F = qE$

unit of electric field - N/C

Other unit is V/m ,

(Since $E = -\frac{dv}{dR}$, electric field is -ve of the potential gradient)

What is the EF due to a point charge (q) - It is the force experienced by the charge IC at A

Let $E(r)$ - Electric field at A due q.

$$F = \frac{1}{4\pi\epsilon_0} \frac{q \cdot 1C}{r^2} \quad E(r) = \frac{1}{4\pi\epsilon_0} \frac{q}{r^2} \quad q \cdots \cdots \cdots \xrightarrow{\text{A}} \bullet \rightarrow$$

Note : If the charge is +ve EF points outward and it is inward if it is -ve

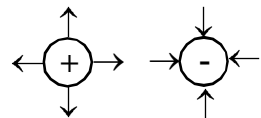

- Write Dimensional formula of intensity of electric field .

$$E = \frac{F}{q} \quad E = \frac{m a}{I t} \quad [E] = \frac{M^1 L^1 T^{-2}}{A^1 T^1}$$

$$[E] = M^1 L^1 A^{-1} T^{-3}$$

- Q1. How can represent electric field around a charge
By Farady EF is represented by Electric line of force
 - Q2. Two field lines never in set Why?
At the point of intersection EF has two directions. At a point EF has only one direction.
 - Q3. How to represent an uniform EF- Electric lines of force are equally spaced parallel lines.
- For isolated +ve charge E1. Field lines starting from the +ve charge and ending to infinity.
- Q4. What is elctric dipole- A system which consists of two equal and opposite charges seperated by a distance.

strength of the dipole is dipole moment $+q \cdots \cdots \cdots \overset{2a}{\cdots \cdots \cdots} - q$

Itis the product of the magnitude of any one of the charge and distance between the charges.

$$P = 2aq$$

Its unit is C - m

- What happens when a dipole is placed in an uniform Electric field.

E - uniform Electric field

Net force acting on the dipole

$$F = -qE + qE = 0$$

Torque acting as the dipole

$$\tau = |F| \times \text{lever arm of forces}$$

$$= qE \cdot 2a \sin \theta$$

$$= PE \sin \theta$$

$$\vec{\tau} = \vec{P} \times \vec{E}$$

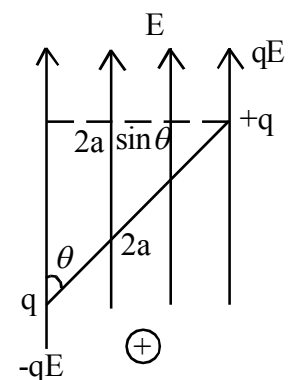

- When a dipole placed in non uniform Electric field it experiences both Force and Torque
- What is dipole field- Electric field around a dipole

i) Expression for electric field at the axial point

A - axial point - (Point on the axis). O - mid point of the dipole

EF at A due to the charge +q

$$E_+ = \frac{1}{4\pi\epsilon_0} \frac{q}{(r-a)^2} \text{ along OA}$$

EF at A due to the charge -q

$$E_- = \frac{1}{4\pi\epsilon_0} \frac{q}{(r+a)^2} \text{ along AO}$$

Net field at A, $E = E_+ - E_-$ (Opposite direction)

$$E = \frac{q}{4\pi\epsilon_0} \left(\frac{1}{(r-a)^2} - \frac{1}{(r+a)^2} \right)$$

$$E = \frac{q}{4\pi\epsilon_0} \frac{4ra}{(r^2 - a^2)^2}$$

$$= \frac{q}{4\pi\epsilon_0} \frac{4ra}{(r^2 - a^2)^2} \text{ using } P = q \cdot 2a$$

Since $r \gg a$, $(r^2 - a^2)^2 \sim r^4$

$$E = \frac{1}{4\pi\epsilon_0} \frac{2P}{r^3} \text{ along OA}$$

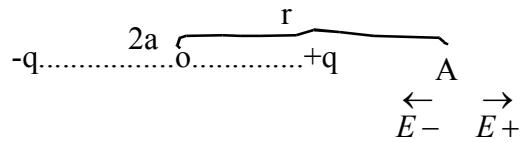

ii) Expression of Electric field at the Equatorial point

A - Equatorial point

$$E_+ = \frac{1}{4\pi\epsilon_0} \frac{q}{r^2 + a^2}$$

$$E_- = \frac{1}{4\pi\epsilon_0} \frac{q}{r^2 + a^2}$$

Net EF at A, $E = E_+ \cos \theta + E_- \cos \theta$

$$E = (E_+ + E_-) \cos \theta$$

$$E = 2 \frac{1}{4\pi\epsilon_0} \frac{q}{(r^2 + a^2)} \frac{a}{(r^2 + a^2)^{1/2}}$$

$$\frac{1}{4\pi\epsilon_0} \frac{P}{(r^2 + a^2)^{3/2}} \quad \left| \begin{array}{l} \text{using} \\ P = q \cdot 2a \end{array} \right.$$

since $r \gg a$

$$(r^2 + a^2)^{3/2} \sim r^3$$

$$E = \frac{1}{4\pi\epsilon_0} \frac{P}{r^3}, \text{ acting parallel to the axis of the dipole.}$$

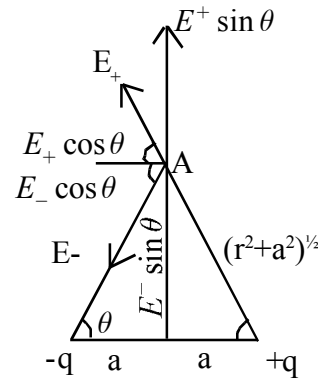

- Compare Electric field at the axial point to that at the equatorial point of a dipole

$$\frac{E_{axial\ point}}{E_{equatorial\ point}} = \frac{\frac{1}{4\pi\epsilon_0} \frac{2p}{r^3}}{\frac{1}{4\pi\epsilon_0} \frac{p}{r^3}} = 2$$

∴ E axial point = 2 E equatorial point for same distance.

What is Electric flux?

$\phi_E = \int_S E \cdot ds$ Surface integral of Electric field.

$|\phi_E| = ES \cos \theta$ where θ is the angle between, E and normal to the surface (s)

When $\theta = 0$ $\phi_E = ES$, Maximum

When $\theta = 90$ $\phi_E = 0$, Minimum

Electric flux (ϕ_E) = Electric field x Total area (if field is normal to the surface)

Its unit is $\frac{N - m^2}{C}$ or v - m

Write Gauss's Theorem:

Total electric flux over a closed surface is directly proportional to the total charge enclosed by the surface.

$$\phi_E \propto q$$

$\phi_E = \frac{q}{\epsilon_0}$, Where ϵ_0 is a constant called permittivity of free space.

Impotence - Help us to calculate the electric field due to a charged body

(i) Electric field due to a straight wire of uniform charge density

ℓ → Length of the straight wire of uniform charge density $\lambda C/m^2$

P → Field point at distance r from the wire

E → Electric field at P due to the wire

Here Gaussian surface is a cylinder of length ℓ and radius r with wire as axis

(Gaussian Surface - Surface we choose to calculate the electric flux)

Total Electric flux over the Gaussian Surface = EF over cylindrical surface + EF over two end faces.

$$\phi_E = E 2\pi r \ell + ES \cos 90 + ES \cos 90$$

$$\phi_E = E 2\pi r \ell.$$

Total charge enclosed by the Gaussian surface $q = \lambda \ell$

$$\text{By Gauss's theorem } E 2\pi r \ell = \frac{\lambda \ell}{\epsilon_0}$$

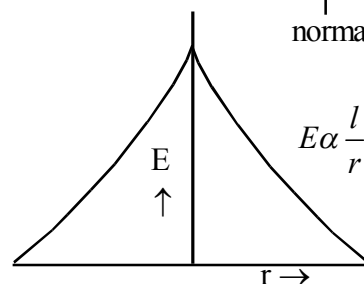
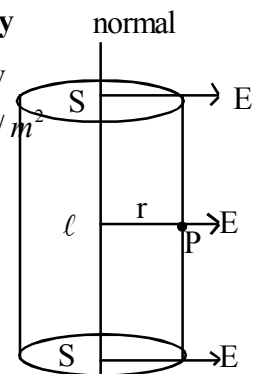

$$E = \frac{l \lambda}{2\pi\epsilon_0 r}$$

It is not uniform since it depends on the distance (r)

(ii) EF due to a plane sheet of uniform charge density

S Plane sheet of uniform charge density, $\sigma \text{ C/m}^2$
 P and P' be the field points at equidistant r from S
 E be the electric fields field at P and P' due to S

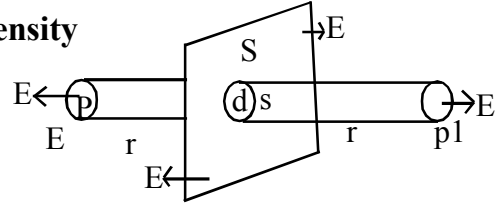

Here Gaussian surface is cylinder of area cross section ds and length 2r

Electric flux over the Gaussian surface = EF over the cylindrical surface + EF over the two end faces.

\therefore Total electric flux over the Gaussian surface $\phi_E = 0 + E ds + E ds = 2E ds$

Total charge enclosed by the Gaussian Surface $q = \sigma ds$

By Gauss's Theorem $2E ds = \frac{\sigma ds}{\epsilon_0}$

$E = \frac{\sigma}{2\epsilon_0}$ It is uniform since it is independent distance

$\sigma > 0$, Electric field is outward from the sheet, $\sigma < 0$, Electric field is towards the sheet.

Case : Electric field due to two Parallel Plane Sheets of Charge

Electric Field at P_I $E_1 = \left(\frac{\sigma_1}{2\epsilon_0} + \frac{\sigma_2}{2\epsilon_0} \right)$

Electric Field at P_{II} $E_2 = \left(\frac{\sigma_1}{2\epsilon_0} - \frac{\sigma_2}{2\epsilon_0} \right)$

Electric Field at P_{III} $E_3 = \left(\frac{-\sigma_1}{2\epsilon_0} + \frac{-\sigma_2}{2\epsilon_0} \right)$

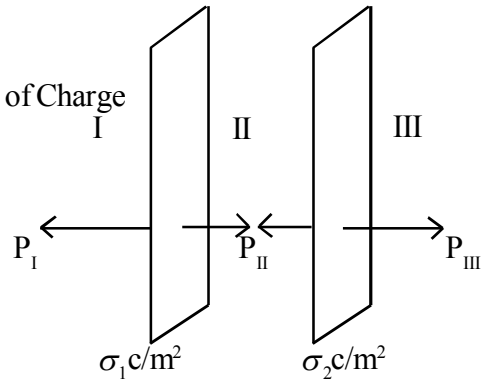

(Since Electric field is measured from left to right)

If $\sigma_1 = +\sigma$, $\sigma_2 = -\sigma$ two sheets of equal and opposite charge densities

$E_1 = 0$, $E_2 = \frac{\sigma}{\epsilon_0}$, Uniform and $E_{3III} = 0$

(iii) Electric field due to a spherical shell of uniform charge density

1) Conducting shell of radius R

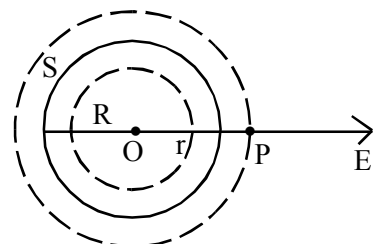

S- Spherical conducting shell of uniform charge σ c/m²

P- Field point at a distance r form O

E - Electric field at P

Here Gaussiann Surface is a sphere of radius r

Case I : If $r > R$, Field point outside the shell

Electric flux over the Gaussian surface $\phi E = E 4\pi r^2$

Total charge $q = 4\pi R^2 \sigma$

By Gauss's theorm $E 4\pi r^2 = \frac{4\pi R^2 \sigma}{\epsilon_0}$

$$E = \frac{R^2 \sigma}{r^2 \epsilon_0}$$

Case II : if $r = R$, field point on the shell $E = \frac{\sigma}{\epsilon_0}$, uniform Magnitude.

Case III : if $r < R$, field point inside the shell, $E = 0$, no charge is enclosed by the inner Gaussian surface

Graphical representation EF due to a shell

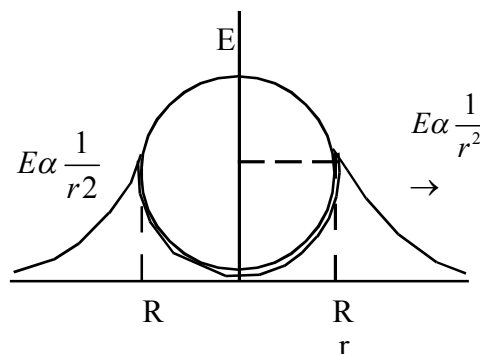

- What is electrostatic shielding - Disappearance of electric field in side a cavity in a conductor

Importance

- During th under accompanied with lighting the safest place is inside a car
- Farady's cage - protect certain instruments from external EF
- Can electro static shielding provided with earthed metal sheet- Yes, how - see the figure

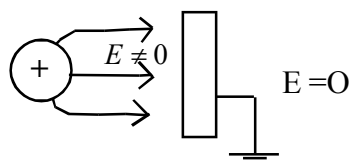

Case - non conducting shell of uniform charge q

a) if $r > R$, $E 4\pi r^2 = \frac{q}{\epsilon_0}$

$E = \frac{1}{4\pi\epsilon} \frac{q}{r^2}$ Charge assumed to be concentrated at the centre

b) $r = R, E = \frac{1}{4\pi\epsilon_0} \frac{q}{R^2}$ Charge enclosed by the inner gaussian surface

c) If $r < R$, Volume charge density, $\frac{q^1}{\frac{4}{3}\pi r^3} = \frac{q}{\frac{4}{3}\pi R^3}$ where q^1 - charge enclosed by the inner Gaussian surface.

(Charge - Volume - Volume charge density)

$$q^1 = q \left(\frac{r}{R} \right)^3$$

$$E \cdot 4\pi r^2 = \frac{q^1}{\epsilon_0} = \frac{q}{\epsilon_0} \left(\frac{r}{R} \right)^3$$

$$E = \frac{1}{4\pi\epsilon_0} \frac{q}{R^3} \times r$$

$$E \propto r$$

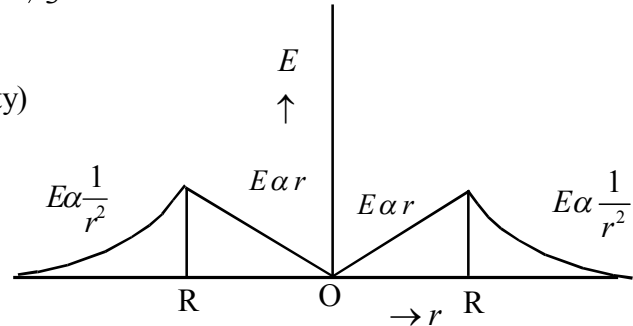

Variation of E1. Field due to a non conducting shell of uniform charge

d) At the centre of the shell $r = 0, E = 0$

Calculate the E Flux from IC charge

Since $\phi_E = \frac{q}{\epsilon_0}$

$$\phi_E = \frac{10 \times 10^{11}}{8.83 \times 10^{-12}} = \frac{10 \times 10^{11}}{8.85} = 1.13 \times 10^{11} \frac{Nm^2}{C}$$

- What is electrostatic potential - Scaler representation of E Field
- Electrostatic P.d between two points in an EF is the work done in bringing unit +ve charge from one point to other.

$$V_B - V_A = W_{AB} \text{ Since } V_B > V_A$$

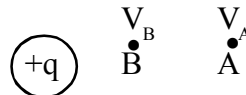

Electrostatic potential at B

Let $V_A = 0$ (Point A is at infinity)

$$V_B = W_{AB} \propto B$$

Electric potential at B is the work done in bringing unit +ve charge from infinity to B

In general, Electric potential at a point is the work done in bringing unit +ve charge from infinity to the point, $V = \frac{W}{q}$

ST Pot difference is the line integral of EF

Force of repulsion experienced by the charge $1c$ at P, $F = 1c \cdot E$

Work done in moving the charge from P through a small distance $d\ell$ against the force.

$$dw = Fd\ell = -Ed\ell$$

$$\therefore \text{Total work done in moving charge from A to B } W_{AB} = \int_A^B -Ed\ell$$

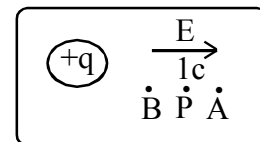

Note : $W = Fd\ell \cos\theta$
When $\theta = 0$
 $W = Fd\ell$

$$V_B - V_A = -\int_A^B E d\ell$$

Expression for Electric potential at B, $V_B = -\int_A^B E d\ell$

ie, Electric Potential is the the -ve line integral of electric field.

Derive expression for Electric Potential due to a point charge

$$EFatA, E = \frac{1}{4\pi\epsilon_0} \frac{q}{\ell^2}$$

Electric potential P, $V = -\int_A^r E d\ell$

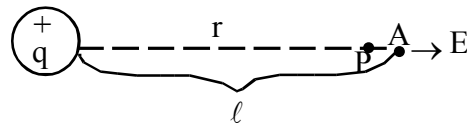

$$= -\int_A^r \frac{1}{4\pi\epsilon_0} \frac{q}{\ell^2} d\ell$$

$$V = \frac{-q}{4\pi\epsilon_0} \int_A^r \ell^{-2} d\ell$$

$$\frac{-q}{4\pi\epsilon_0} \left(\frac{-1}{\ell} \right)_A^r$$

$$V = \frac{1}{4\pi\epsilon_0} \frac{q}{r}$$

Note : $\int \ell^{-2} d\ell = \frac{\ell^{-2+1}}{-2+1}$
 $= -1/\ell$

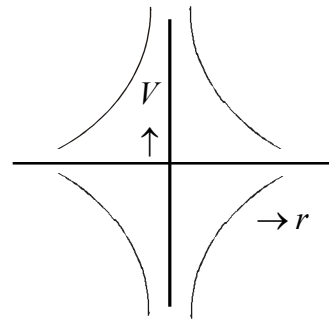

If q is placed in medium of relative permittivity ϵ_r , $V = \frac{1}{4\pi\epsilon_0\epsilon_r} \frac{q}{r}$

- Can a sphere of radius 1 cm hold charge 1C ,
No. Its potential become very large.

$$V = \frac{1}{4\pi\epsilon_0} \cdot \frac{q}{r} \quad V = \frac{9 \times 10^9 \text{ IC}}{1 \times 10^{-2}} = 9 \times 10^{11} = 9 \times 10^{11} \text{ Volt}$$

- Electric field is the -ve of Potential gradient, $E = \frac{-dv}{d\ell}$
- If the electric field intensity at a given point is zero, will electric potential necessarily be zero at that point - No. Since $E = \frac{-dv}{d\ell}$ if $E=0$, $\frac{-dv}{d\ell} = 0$

$\therefore V$ is constant

- Draw variation of EF and EP with respect to a distance from a point charge

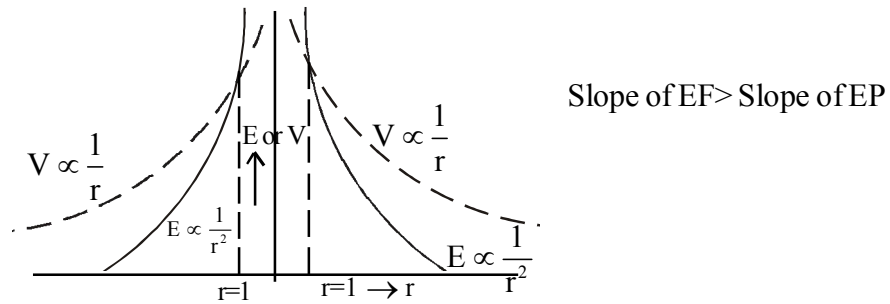

- What is the electric potential at a point A of due to a dipole

$$V = \frac{1}{4\pi\epsilon} \frac{P \cos\theta}{r^2} \text{ Where } P \text{ dipole moment}$$

At the axial point

$$\theta = 0, V = \frac{1}{4\pi\epsilon_0} \frac{P}{r^2}$$

At the equatorial point $\theta = 90, V = 0$

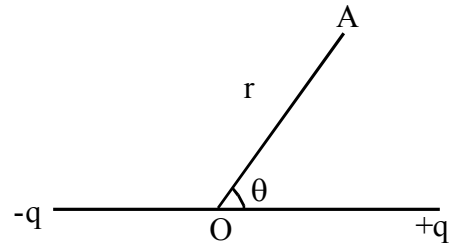

- What in the EF and EP at the mid point of a dipole

At the centre O, resultant EF = $E_{++}E_{--}$

$$\begin{aligned} E &= E_+ + E_- \\ &= \frac{1}{4\pi\epsilon_0} \frac{q}{a^2} + \frac{1}{4\pi\epsilon_0} \frac{q}{a^2} \\ &= 2 \left(\frac{1}{4\pi\epsilon_0} \frac{q}{a^2} \right) \end{aligned}$$

At the mid point O, $V = V_+ + V_-$

$$\begin{aligned} &\frac{1}{4\pi\epsilon} \frac{q}{a} + \frac{1}{4\pi\epsilon_0} \frac{-q}{a} \\ &= 0 \end{aligned}$$

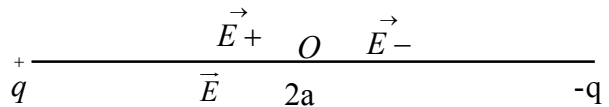

Note: V- due to +ve charge is +ve
that of -ve charge is -ve.

- **Capacitor** : System of two conductors separated by a dielectric medium.

Which is used to store Electric charge and hence energy

Capacitance : Ability to store electric charge

When a Charge Q is given to a conduct its potential increases to V.

ie, $V \propto Q$

$$V = CQ - \text{Where } C - \text{Capacitance}$$

- Its unit is Farad (f)

$$f = \frac{IV}{IC}$$

Slope of graph $C = \frac{Q}{V}$

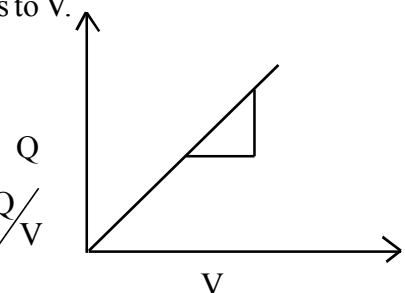

- When charge given to a conductor is doubled what is it potential - It is doubled, since $V \propto Q$
- Is a single conductor posses capacitance. Yes - Seceond conductor is at infinity

- Principle of capacitor - An earthed conductor is placed near a charged conductor the capacitance of the charged conductor increases (use of earthed conductor - It reduces the potential)
- Capacitance of an isolated spherical conductor of radius R

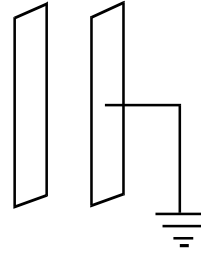

$$C = \frac{Q}{V}$$

$$C = 4\pi\epsilon R \quad \text{But } V = \frac{1}{4\pi\epsilon} \frac{Q}{R}$$

$$C \propto R \quad (\text{Where 'R' is the radius})$$

- What happens when the second plate of a parallel plate capacitor is earthed. Potential difference reduces

Explain Capacitance of a Parallel plate capacitor

A - surface area of each plate

d - Distance between the plates

+Q - charge given to a plate P₁

By induction plate P₂ acquires the charge -Q

∴ Surface charge density on each plate $\sigma = \frac{Q}{A}$

$$Q = \sigma A$$

The EF between two plates $E = \frac{\sigma}{\epsilon_0}$

PD between the plates $V = Ed$

$$V = \frac{\sigma}{\epsilon_0} d$$

$$C = \frac{Q}{V} = \frac{\sigma A}{\frac{\sigma}{\epsilon_0} d} = \frac{\epsilon_0 A}{d}$$

If the plates are separated by a medium of dielectric constant ϵ_r , $C = \frac{\epsilon_0 \epsilon_r A}{d}$

Case (i) : What is the capacitance of a parallel plate capacitor -

When a conducting slab of thickness t is placed b/w the plates

Reduced p.d b/w the plates

$$V^1 = E(d - t) = \frac{\sigma}{\epsilon_0} (d - t)$$

$$C^1 = \frac{Q}{V^1} = \frac{\sigma A}{\frac{\sigma}{\epsilon_0} (d - t)}$$

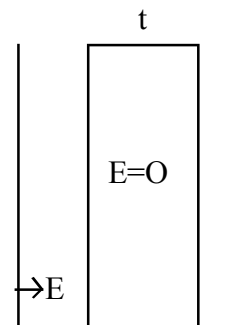
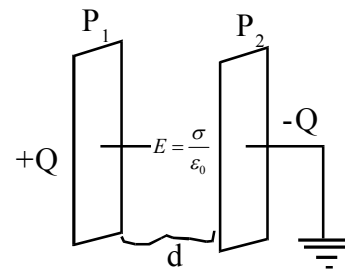

$$\frac{\epsilon_0 A}{d(1 - \frac{t}{d})} = \frac{C}{1 - \frac{t}{d}}$$

If $t=d$, $C \Rightarrow$ infinity

(ii) When an insulating slab of thickness t is placed b/w the plate

Reduced pd b/w the plates $V^{11} = E(d-t) + \frac{E}{\epsilon_r} t$ Where $E = \frac{\sigma}{\epsilon_0}$

$$V = \frac{\sigma}{\epsilon_0} \left[d - t + \frac{t}{\epsilon_r} \right]$$

$$C = \frac{Q}{V^{11}} = \frac{\sigma A}{\frac{\sigma}{\epsilon_0} \left(d - t + \frac{t}{\epsilon_r} \right)}$$

$$= \frac{\epsilon_r \epsilon_0}{\epsilon_r d - \epsilon_r t + t} = \frac{\epsilon_0 \epsilon_r A}{d \left[\epsilon_r \left(1 - \frac{t}{d} \right) + \frac{t}{d} \right]} \quad \therefore C^{11} = \frac{\epsilon_r C}{\epsilon_r \left(1 - \frac{t}{d} \right) + \frac{t}{d}}$$

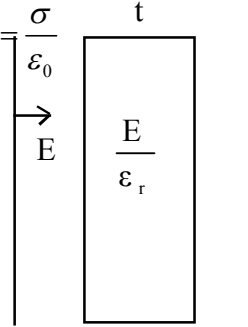

When $t=d$, $C^{11} = \epsilon_r C$ its capacitance increases, Faradays Explanation.

- What is equi potential surfaces
The surface over which electric potential has constant value.
- Eg:-
- For a point charge equipotential surfaces are the surface of spheres with charge q as the centre
 - The planes \perp to the uniform EF b/w two charged parallel plates

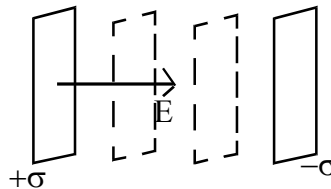
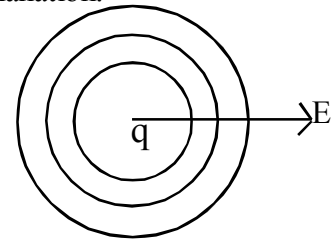

- In the fig what is the workdone in moving a charge q from A to B

$$V_A - V_B = \frac{W}{q}$$

$$\text{Since } V_A = V_B \quad \therefore W = 0$$

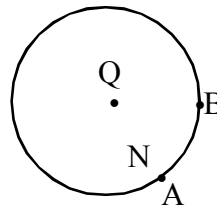

Work done in moving a charge in an EF

- $w=qv$, this work is stored as PE,
 $U = qv$
- What is the expression for velocity of charge q moving in an EF of potential V
By conservation of energy $qV = \frac{1}{2} mv^2$

$$v = \sqrt{\frac{2qV}{m}}$$

- Expression for Potential energy of a system of two charges

$$V = \frac{q_1 q_2}{4 \pi \epsilon_0 r_{12}}$$

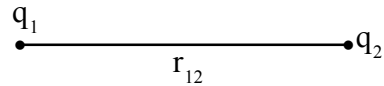

- Unit of the electrostatic PE electron volt (eV)

$$1 \text{ eV} = 1.6 \times 10^{-19} \text{ J}$$

- Time period of oscillation of a dipole in uniform EF

since torque $\tau = PE \sin \theta$, Where θ angular displacement

$\tau = PE \theta$ when θ is small

Angular acceleration, $\alpha = \frac{d^2 \theta}{dt^2}$

But $\tau = I \alpha$ Where I - Moment of Inertia

$$\frac{d^2 \theta}{dt^2} + \frac{PE}{I} \theta = 0 \quad (-\text{ve sign show Torque decreases } \theta)$$

$$\frac{d^2 \theta}{dt^2} + \frac{PE}{I} \theta = 0, \text{ Equation for SHM, } \frac{d^2 x}{dt^2} + \omega^2 x = 0$$

$$\text{Frequency of oscillation } \omega = \sqrt{\frac{PE}{I}}$$

$$\therefore \nu = \frac{\omega}{2\pi} = \frac{1}{2\pi} \sqrt{\frac{PE}{I}}$$

$$\text{Time period } T = \frac{2\pi}{\omega} = 2\pi \sqrt{\frac{I}{PE}}$$

- PE of a dipole in an E1 field.

$$W = \int_{\theta_1}^{\theta_2} \tau d\theta$$

$$= \int_{\theta_1}^{\theta_2} PE \sin \theta d\theta$$

$$= -PE (\cos \theta)_{\theta_1}^{\theta_2}$$

$$= -PE (\cos \theta_2 - \cos \theta_1)$$

When $\theta_1 = 90^\circ$, $\theta_2 = \theta$

$$U = -PE$$

Since $\tau = PE \sin \theta$
 $\tau \propto \sin \theta$
 τ variable

Polar and non Polar dielectrics(Insulators)

Polar Dielectric

- i) In each atom the two centres of charges do not coincide (Atomic dipole)
- ii) It has Permanent dipole moment
- iii) In an external electric field it experiences torque

Eg : H_2O, NH_3

Non Polar dielectric

- i) In each atom the two centres of charges coincide
- ii) It has zero dipole moment
- iii) In an external electric field it experiences induced dipole moment

Eg : H_2, N_2, O_2

+ve centre of charge produced by protons and -ve centre of charge produced by electrons.

- What happens when a non polar dielectric is placed in an EF? Induced dipole moment takes place. In an external EF, in each non polar dielectric atom +ve centre of charge and -ve centre of charge are separated a small distance.
- What is electric polarisation - Induced dipole moment in non polar dielectric in an EF

- What is the EF inside a dielectric

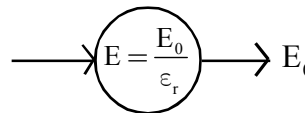

In an external field $E = \frac{E_0}{\epsilon_r}$

E_0 - External Electric field

- **Behaviour of a conductor in an EF**

(Electrostatics of Conductor)

1. Inside the conductor the electric field is zero
2. Electric charges can be seen only on the surface
3. Outside the conductor EF is normal to the surface of the conductor
4. Surface of the conductor is an equipotential.

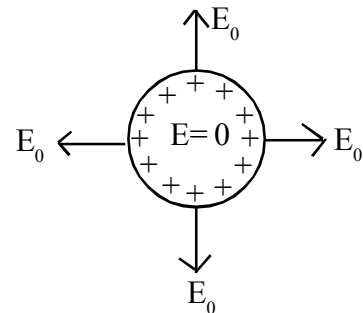

- **Calculate dielectric constant of a conductor**

Since $\epsilon_r = \frac{E_0}{E}$

For a conductor $E=0$, $\epsilon_r = \frac{E_0}{0} \Rightarrow \text{infinity}$

- What is the capacitance of a parallel plate capacitor of n plates

Capacitance of a parallel plates capacitor - having n - plates $C = (n-1) \frac{\epsilon_0 A}{d}$

- Dielectric constant or Relative Permittivity (ϵ_r) of a medium is the factor by which the capacitance of capacitor increases. Since $C'' = \epsilon_r C$

Expression for energy stored in a capacitor - During charging the capacitor, at a particular stage

$\pm q$ - be the charge, corresponding potential difference is V

Hence work required to give additional charge dq

$$dw = V dq \quad \text{but } V = \frac{q}{C} = \frac{q}{C} dq$$

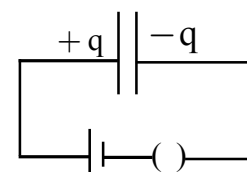

∴ Total work done to charge the capacitor from O to Q (max)

$$w = \int_0^Q dw = \frac{1}{C} \int_0^Q qdq = \left[\frac{q^2}{2C} \right]_0^Q = \frac{Q^2}{2C}$$

This work is stored as PE, $U = \frac{Q^2}{2C}$

Put $Q = CV$

$$U = \frac{1}{2} CV^2$$

OR

Note: since, work done =

Area under the $\Delta OAB = \frac{1}{2} VQ$

Put $Q = CV$, $W = \frac{1}{2} CV^2$.

Hence Energy stored $U = \frac{1}{2} CV^2$

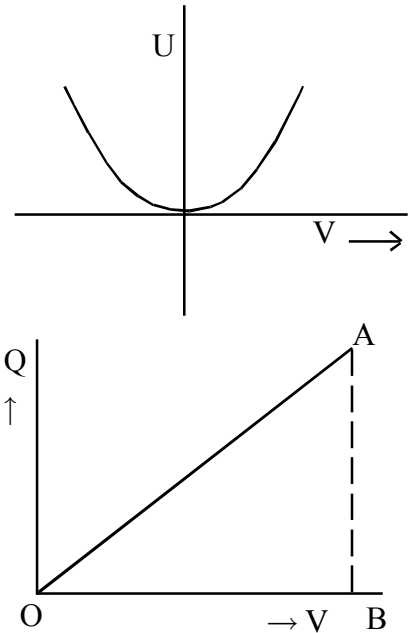

Energy density of the parallel plate capacitor

It is the energy stored/ unit volume, $\frac{U}{Ad}$

$$= \frac{1}{2} \frac{CV^2}{Ad} = \frac{1}{2} \frac{\epsilon_0 A}{dAd} V^2 \quad \text{using } C = \frac{\epsilon_0 A}{d}$$

$$= \frac{1}{2} \epsilon_0 \left(\frac{V}{d} \right)^2$$

$$= \frac{1}{2} \epsilon_0 E^2 \text{ (J/m}^3\text{)} \quad \text{(since } Pd = E \cdot F \times \text{distance } V = Ed\text{)}$$

Hence the energy stored in a capacitor is in the form of electric field.

Explain combinations of capacitors

1) Series Combination

Reduces the effective capacitance

From Fig.(1) $V = V_1 + V_2$

$$V = \frac{Q}{C_1} + \frac{Q}{C_2} \dots\dots\dots(1)$$

$$\text{From fig (2) } V = \frac{Q}{C_{\text{eff}}} \dots\dots(2)$$

$$\text{From eqs(1) and (2) } \Rightarrow \frac{1}{C_{\text{eff}}} = \frac{1}{C_1} + \frac{1}{C_2} \quad \therefore C_{\text{eff}} = \frac{C_1 C_2}{C_1 + C_2}$$

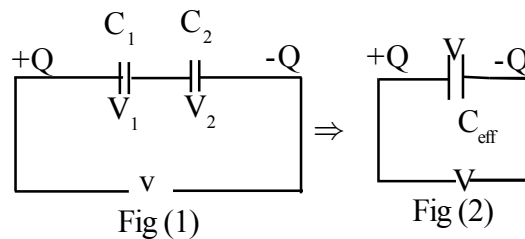

(Note : Charge will be same)

1) Parallel Combination

Increases the effective capacitance

From Fig.(1) : $Q = Q_1 + Q_2$
 $= (C_1 + C_2)V \dots\dots\dots(1)$

From Fig.(2) : $C_{eff} V \dots\dots\dots(2)$

From eqs (1) and (2) $C_{eff} = C_1 + C_2$

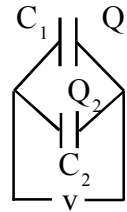

Fig(1)

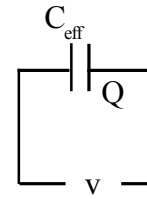

Fig(2)

Note : Potential will be same

- A, B, C and D are equally spaced equipotential surfaces inclined of at angle of 100° with X-axis

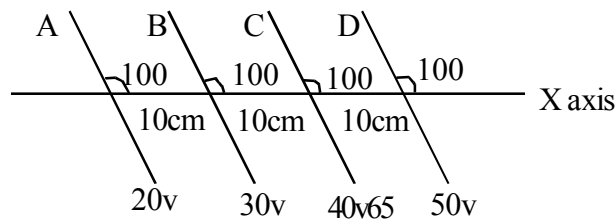

- Predict the direction of \vec{E} in terms of angle w.r to +ve x-axis.
- Find the magnitude of the Electric field.

- Direction of \vec{E} along 190° w.r to x-axis

b) $|E| = \frac{dv}{dr} = \frac{10}{10 \cos 10} \text{ v/m}$

- Find the effective capacitance in b/w A and B

$C_1 = C_2 = C_3 = 3\mu F$ $C_{eff} = 3\mu F$

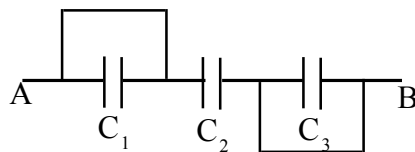

Chapter 2

CURRENT ELECTRICITY

The branch of Physics which deals with motion of charges is called current Electricity.

- What is electric current? Give its direction

The rate of flow of charge through any section of a conductor is the electric current.

$$\text{Electric current} = \frac{\text{charge}}{\text{time}}$$

$$I = \frac{\Delta q}{\Delta t}$$

- Unit of current is Ampere. $1A = \frac{1C}{1S}$ it is a scalar quality. Direction of flow of positive charge (direction opposite to the flow of negative charge) is taken as the direction of current.
- If the current through a conductor does not vary with time, it is said to be steady current. If it varies with time, the instantaneous value of current is given by

$$I(t) = \frac{dq(t)}{dt}$$

- What are the charge carriers in metal, semiconductor and electrolytes.

In metal free electrons are the charge carriers

In semiconductor free electrons and holes

In electrolytes and gases +ve and -ve ions

- What is electromotive force (EMF)

An electric current can be maintained in a conductor only if a potential difference exists between its ends. A device which can provide a potential difference across two points is called EMF source. (For eg : cell)

The EMF of the source is numerically equal to the work done on a unit charge in order to drive it once around the closed circuit containing the source. Its unit is Volt.

- Explain drift velocity and obtain an expression for it.

When a potential difference V volt is applied across the length ' ℓ ' of the conductor using a cell an electric field $E = \frac{V}{\ell}$ establishes at every point along the length of the conductor.

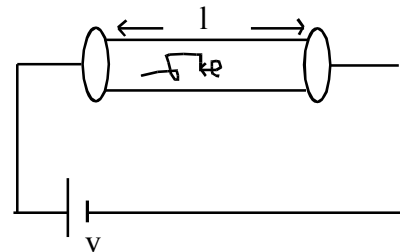

∴ Each electron will experience a force $F = -eE$ (Direction of force is opposite to the direction of E)

∴ Acceleration of each electron $a = \frac{F}{m} = \frac{-eE}{m}$ (Where m is mass of electron)

Velocity imposed on each electron, $V_d = a\bar{t} = V_d = \frac{-eE}{m}\bar{t}$ where-relaxation time - average time between successive collision of free e^- with +ve ions.

- Obtain an expression for current in terms of drift velocity.

Consider a conductor of length 'l' and uniform area cross section A. Let 'n' be number of free e^- per unit volume. Consider a small section Δ of the conductor.

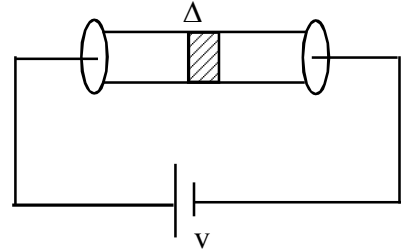

Let Δ be the time taken by electrons to cross the section Δ

Number of e^- in the section, $N = nA\Delta$

Charge Δ in the section = $nA\Delta \cdot e$

$$\text{Current } I = \frac{\Delta q}{\Delta t} = \frac{nA\Delta l e}{\Delta t} = nAeV_d$$

$$\text{Current density } j = \frac{I}{A} = neV_d$$

$$\left(I = \vec{j} \cdot \vec{A} \right)$$

- **State and explain Ohm's law**

Ohm's law states that the current passing through a conductor is directly proportional to potential difference applied across it, when the temperature is kept constant.

At constant temperature $I \propto V$.

or $V \propto I$

ie, $V = IR$

or $\frac{V}{I} = R$, a constant (R is called Resistance of the conductor)

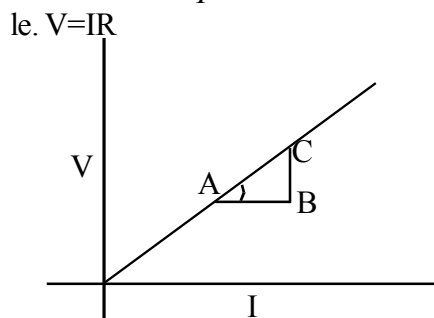

Unit of R is Ohm (Ω). Reciprocal of R is called

conductance $C = \frac{1}{R}$. Its unit is Ω^{-1}

slope of V- I graph = $\text{Tan } \theta = \frac{BC}{AB} = \frac{\Delta V}{\Delta I} = R$, Resistance

- Derive ohm's law

We have $I = neAV_d$

$$\text{but } V_d = \frac{eE}{m}\tau = \frac{e}{m} \frac{V}{l}\tau \quad \left(\text{Since } E = \frac{V}{l} \right)$$

$$I = neA \frac{eV\tau}{m\ell}$$

$$\text{By } \Omega \text{'s law } \frac{V}{I} = R$$

$$\frac{V}{I} = \frac{m\ell}{ne^2 A\tau} = \text{a constant (R)} \quad \text{ie, } R = \frac{m\ell}{ne^2 A\tau}$$

- What are the factors effecting resistance of a conductor
 - a. Resistance R is directly proportioned to length 'ℓ' of the conductor ($R \propto \ell$)
 - b. Inversly proportioned to Area of cross section of the conductor ($R \propto \frac{1}{A}$)
 - c. Depends on nature and temp. of the material ($R \propto T$).
- Expression for specific resistance

- Since $R \propto \ell$

$$R \propto \frac{\ell}{A}$$

$$\text{or } R \propto \frac{\ell}{A}$$

$$= \frac{\rho \ell}{A} \quad \text{Where } \rho \text{ is called specific resistance or resistivity. } \rho = \frac{RA}{\ell}$$

- We have $R = \frac{m\ell}{ne^2 A\tau}$

$$\therefore \rho = \frac{m}{ne^2 \tau}$$

$$\rho = \left(\frac{m}{e^2} \right) \frac{1}{n} \frac{1}{\tau}, \text{ it depends on nature of material (n) and Temperature}$$

(Note: When temperature increases τ decreases)

- Unit of ρ is Ω
- Reciprocal of ρ called conductivity $\sigma = \frac{1}{\rho}$ (unit Ω^{-1} -)
- Since Note : $R = \frac{\rho \ell}{A}$, When $\ell = 1\text{m}$, $A = 1\text{m}^2$ $R = \rho$

\therefore Sp. resistance of a material is defined as the resistance of unit length and unit area of cross section.

- Explain the temperature dependence of Resistance (or Resistents)

$$\text{We have } \rho = \frac{m}{ne^2 \tau}$$

When temp of a metallic conductor increases, the thermal speed of free e⁻ increases and hence

relaxation time τ decreases. \therefore Resistivity (and Resistance) increases with increase in temperature.

- Temperature coefficient of resistance

ρ - Resistivity of 0°C ,

Δ - Increase in temperature.

α - Temperature coefficient of resistivity

$$\rho = \rho(1 + \alpha \Delta)$$

$$\text{or } \alpha = \frac{\rho - \rho_0}{\rho_0 \Delta} \text{ or } \alpha = \frac{R - R_0}{R_0 \Delta T}$$

α is +ve for metals, (Eg: Cu, Al etc)

For semiconductors α is -ve, ie, when temp. increase resistance (or Resistivity) decreases. (eg: Si, Ge). For insulator, $\alpha = 0$.

- For certain alloys like manganin, constantan the value of α is very small (nearly zero). The resistance (or resistivity) of these substances remain constant when temp varies. So these alloys are preferred for making standard resistors and Resistance boxes.

Colour code of Resistors

The resistance value of commercially available carbon resistors are usually represented using certain standard colour codes.

First two bands indicate the first two significant digits and third coloured band indicates the multiplier. The last band indicates percentage tolerance.

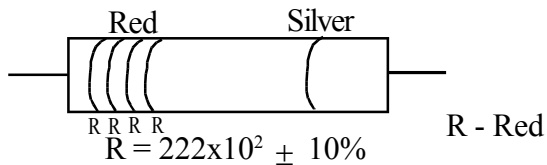
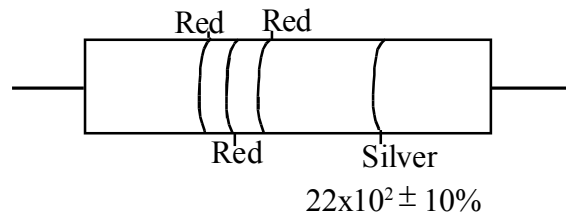

Value of colour codes			
Colour	Value	Multiplier	Tolerance
Black	0	10^0	-
Brown	1	10^1	-
Red	2	10^2	-
Orange	3	10^3	-
Yellow	4	10^4	-
Green	5	10^5	-
Blue	6	10^6	-
Violet	7	10^7	-
Grey	8	10^8	-
White	9	10^9	-
Gold	-	10^{-1}	5%
Silver	-	10^{-2}	10%
No colour	-	-	20%

- Write the colour code for $1\text{K}\Omega \pm 10\%$
 $1\text{K}\Omega = 1 \times 10^3 \Omega = 10 \times 10^2 \pm 10\% \Rightarrow$ Brown, Black, Red, Silver
- **Failures of 'ohms' law**
 1. $V \propto I$, only for small value of current.
 2. The relation between V and I depends on the sign of V.
 3. The relation between V and I is non unique.

Combination of resistance

a. Series

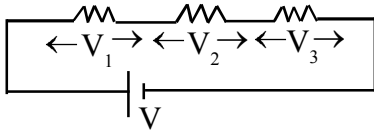

In Series combination current is same (I) through R_1 , R_2 , and R_3

$$\therefore \text{P.d across } R_1, V_1 = IR_1$$

$$\text{P.d across } R_2, V_2 = IR_2$$

$$\text{P.d across } R_3, V_3 = IR_3$$

$$\therefore \text{Total applied } V = V_1 + V_2 + V_3$$

$$V = I (R_1 + R_2 + R_3)$$

$$\frac{V}{I} = R_1 + R_2 + R_3$$

$$R_{\text{eff}} = R_1 + R_2 + R_3$$

le. In series combination equivalent resistance is the sum of individual resistance. Equivalent value is greater than the highest individual resistor.

For 'n' identical resistors R in series, Effective value $R_s = nR$

b. Parallel

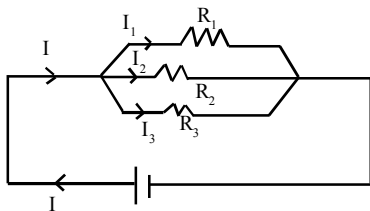

In parallel combination P.d across each resistor is same (V) \therefore Current through each Resistor is

$$\text{given by } I_1 = \frac{V}{R_1}, I_2 = \frac{V}{R_2}, I_3 = \frac{V}{R_3}$$

\therefore Current drawn from the cell

$$I = I_1 + I_2 + I_3$$

$$= \frac{V}{R_1} + \frac{V}{R_2} + \frac{V}{R_3}$$

$$= V \left(\frac{1}{R_1} + \frac{1}{R_2} + \frac{1}{R_3} \right)$$

$$\frac{I}{V} = \frac{1}{R_1} + \frac{1}{R_2} + \frac{1}{R_3}$$

$$\frac{1}{R_{eff}} = \frac{1}{R_1} + \frac{1}{R_2} + \frac{1}{R_3}$$

Reciprocal of effective resistance is the sum of reciprocal of individual resistor. Equivalent resistance in parallel combination is less than the least individual resistance.

For 'n' identical resistors in parallel

$$\frac{1}{R_p} = \frac{n}{R}$$

$$\therefore R_p = \frac{R}{n}$$

- What is the difference between terminal P.d & EMF of a cell.
EMF of a cell is the work done on a unit charge in order to drive it once around the closed circuit containing the cell.
Terminal P.d. is the work done on a unit charge in driving it from the +ve to -ve terminal of the cell through the external load.
- What is internal resistance of a cell.
Resistance offered by the electrolyte and electrodes of a cell when current flows through it is called internal resistance (r)
It depends on
 1. Distance between electrode
 2. Nature of electrolytes and electrodes
 3. Area of electrodes immersed in electrolyte.
 4. Temperature

• Expression for internal resistance of a cell

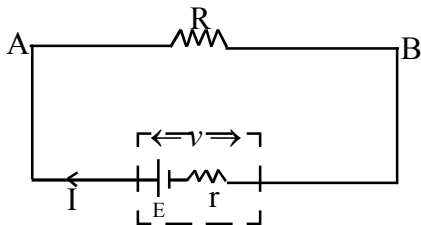

In the circuit shown

$$I = \frac{E}{r + R}$$

$$V = E - Ir$$

$$= E \left(1 - \frac{r}{r + R}\right)$$

$$r = R \left(\frac{E}{V} - 1\right)$$

Note : $E = V + Ir$ (during charging) or $V = E - Ir$ (during discharging)

Where V - Terminal Pd

E - EMF

r - Internal Resistance

When $I = 0$, $E = V$

The EMF of a cell is also defined as the terminal P.d across the cell when it is not sending.

Ir - lost volt - potential drop due to internal resistance.

Also $V = IR$

• Kirchoff's Rules - State and Explain Kirchoff's Rule

First Rule (Kirchoff's Current law)

Algebraic sum of currents meeting at a junction in a circuit is zero. At a junction $\sum I = 0$

The sum of currents entering a junction is equal to sum of current leaving that junction.

Consider the circuit shown below.

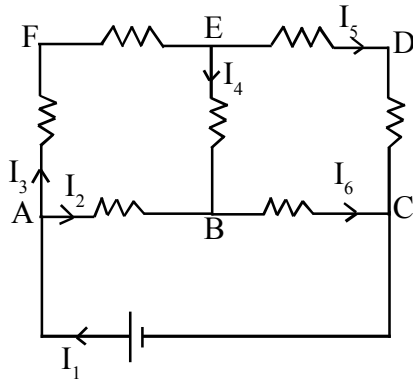

using Kirchhoff's Current rule at junction A,

$$I_1 - I_2 - I_3 = 0$$

or $I_1 = I_2 + I_3$

At junction E, $I_3 - I_5 - I_4 = 0$

$$I_3 = I_4 + I_5$$

This law is in accordance with conservation of charge. That is In any circuit total amount of electric charge reaching a point at any instant is equal to the total charge leaving that point at that instant.

Second Rule (Kirchhoff's Voltage law)

Algebraic sum of changes in potential in any closed loop is zero. That is $\sum V=0$ in a closed loop.

This law is in accordance with law of conservation of energy.

consider the circuit shown below

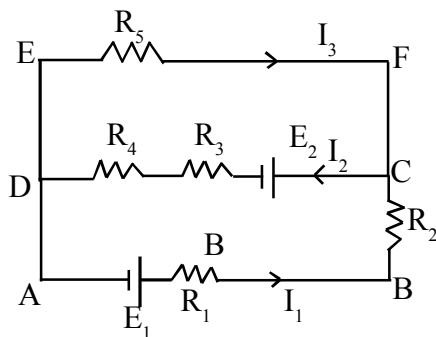

Using KVL in the mesh ABCDA

$$E_1 - I_1 R_1 - I_1 R_2 - E_2 - I_2 R_3 - I_2 R_4 = 0$$

Using KVL in the mesh DCFED

$$+I_2 R_4 + I_2 R_3 + E_2 + I_3 R_5 = 0$$

(Higher potential to low is treated as negative and law to higher is treated as positive)

Wheatstone's Bridge

- What is Wheatstone's bridge and obtain a condition for balancing the bridge.

It is an arrangement using four resistor as shown in figure. It is used to find unknown resistance.

Current through different branches are shown in figure. The current through Galvanometer is I_g and hence galvanometer shows a deflection.

To find unknown resistance, adjust the values of known resistor P, Q and S so as to make galvanometer deflection as zero (That is $I_g=0$). Now the bridge is said to be balanced. The circuit diagram of the balanced bridge is shown below.

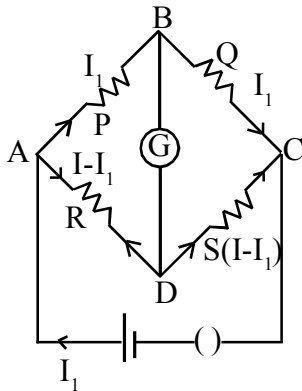

Now applying KVL in the loop ABDA,

$$- I_1 P + (I - I_1) R = 0$$

$$I_1 P = (I - I_1) R \dots\dots\dots 1$$

In the mesh BCDB

$$- I_1 Q + (I - I_1) S = 0$$

$$I_1 Q = (I - I_1) S \dots\dots\dots 2$$

$$\frac{①}{②} \Rightarrow \frac{P}{Q} = \frac{R}{S} \text{ This is the balancing condition of the bridge (Wheatston's Principle)}$$

Note: If the position of galvanometer and cell in a balanced bridge interchanged, there is no change in balancing condition (The galvanometer still shown zero deflection)

But the equation is $\frac{P}{R} = \frac{Q}{S}$.

Metre Bridge

- Explain the principle of Metre Bridge and how resistance can be measured using it.
Metre Bridge is a device used to find resistance of a wire (resistor) using wheatston's priciple.
Shemetic diagram of metre bridge is shown below.

To find the unknown resistance X, the bridge should be balanced by moving the sliding contact D (Jockey) along the wire AC (1m length uniform wire) When the gelvanometer shows zero deflection, the bridge is balanced and measure the balancing length 'l' from the end A. (From the side where unknown resistor X is connected)
Now using Wheatston's priciple.

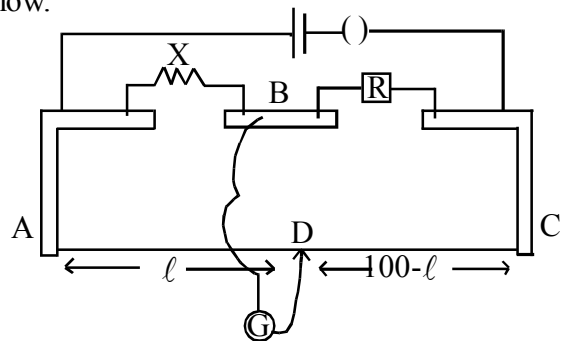

$$\frac{X}{R} = \frac{R_{AD}}{R_{DC}} \dots\dots\dots 1$$

But $R_{AD} = l\sigma$ Where σ is resistance per unit length metre bridge wire.

$$R_{DC} = (100 - l)\sigma$$

$$= \frac{X}{R} = \frac{l\sigma}{(100-l)\sigma}$$

$$\frac{X}{R} = \frac{l}{100-l}$$

$$X = \frac{Rl}{100-l}$$

Potentiometer

A Potentiometer consists of 10m long uniform resistance wire fixed on a wooden platform.

Principle : When a constant current is passed through the potentiometer wire, the p.d across any two points of the wire is directly proportional to the length between the points.

If A and B are two points separated by length ' ℓ ' $V_{AB} = I R_{AB}$

or $V_{AB} = (IR_r)\ell$ where R_r is resistance/length of the potentiometer wire.

$V \propto \ell, IR_r$ - Potential gradient is a constant.

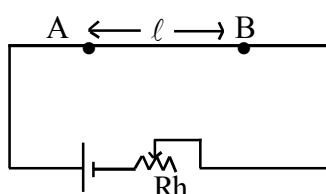

Uses

- 1) Measure emf of a cell
- 2) Compare emf's of two cells
- 3) Internal resistance of a cell

Measurement of emf

The cell whose emf is to be measured is connected in the potentiometer as shown below.

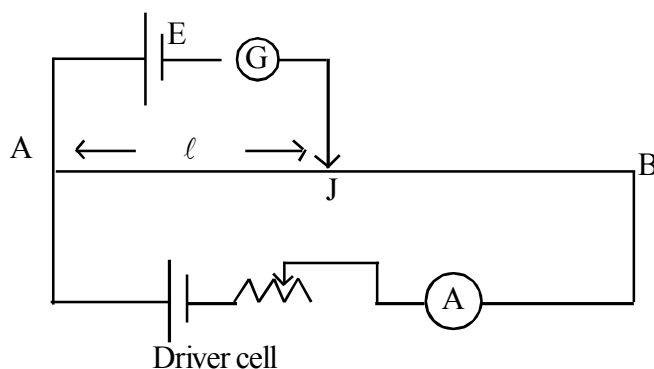

Now slide the jockey along the potentiometer wire till galvanometer shows zero deflection.

Now the current through the cell E becomes zero

Emf of the cell $E = V_{AJ}$

But using the principle of potentiometer $V_{AJ} = IR_r \ell$

Where ℓ is the length between A & J

$E = IR_r \ell$

Knowing R_r of the potentiometer wire and by measuring balancing length for a known current I , emf of the cell can be measured.

Precautions

- 1) Emf of the cell in the primary should be greater than that in the secondary.
- 2) The potentiometer point A always +ve w.r. to B
- 3) Current should be passed for a small time.

Advantages of a Potentiometer over a voltmeter

If we use a voltmeter to measure emf of a cell, due to the finite resistance of the voltmeter, a current will be drawn from the cell. So the measured value will be only terminal p.d not emf.

Emf of a cell can be measured only if no current is drawn from the cell while measuring the emf. This is made possible in Potentiometer. (Null method)

Measurement of internal resistance of a cell

Figure shows the connections.

Internal resistance of the cell in the primary is r .

When the cell is in the open circuit.

(Close the plug key K_1 and open plug Key K_2)

Now emf of the cell E appears in the $E \propto \ell_1$ - ①

Primary ℓ - corresponding balancing length

When the Cell is in the closed circuit (Close both K_1 and K_2)

Introduce a certain resistance in R . Now terminal potential difference V of the cell appears in the primary,

ℓ_2 corresponding balancing length.

$$V \propto \ell_2 \text{ - ②}$$

But $V = IR$

$$V = \frac{E}{r + R} R, \quad \frac{ER}{r + R} \propto \ell_2 \text{(3)}$$

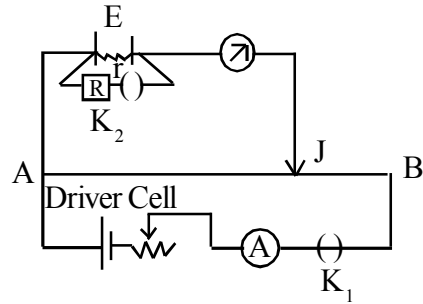

Note: $r = R \left(\frac{E}{V} - 1 \right)$

$$= \frac{(1)}{(3)}, \quad \frac{r + R}{R} = \frac{\ell_1}{\ell_2}, \quad r = R \left(\frac{\ell_1}{\ell_2} - 1 \right)$$

- * As the external resistance R increases, internal resistance of cell increases.
- * It is easier to start a car engine on a warm day than on a chilly day - on warm day the internal resistance of the car battery decreases. Large current can be drawn from the battery.
- * In the potentiometer circuit shown the balance point is at J . state with reason where the balance point will be shifted when

a) Resistance R is decreased keeping all parameters unchanged.

$$E = (IR + rI) \ell$$

Potential gradient $IR \ell$ is increased. If E is constant.

So balancing length AJ decreases.

b) Resistance S is increased keeping R constant.

At null point no current drawn from the cell E . Hence no effect.

(Resistance S is used only to protect the galvanometer)

c) The driver cell in the primary is replaced by another cell whose emf is lower than that of E .

Balance point not found on the potentiometer wire. Because Pd across the potentiometer wire is less than the emf of the cell E .

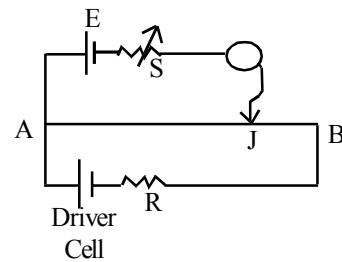

- The variation of V with ℓ in the case of two potentiometers X and Y shown which one of these two

will you prefer for comparing emf's of cells why $\rightarrow Y$ - potential gradient $\frac{V}{\ell}$ is low.

(Slope of the graph) So it is highly sensitive.

- * Electric power - Electrical energy consumed by an instrument in 1 Second.

$$P = \frac{W}{t}, \quad P = IV = I^2 R = \frac{V^2}{R}$$

Its unit is watt.

$$1 \text{ Watt} = 1 \text{ amp} \times 1 \text{ Volt}$$

(Since $P = IV$)

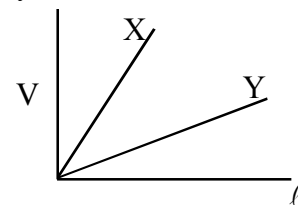

Note : Electrical energy work done by electric current in a given time

$$W = I^2 R t = IV t = \frac{V^2}{R} t$$

- Three bulbs 40, 60 and 100w are designed to work on 220v mains. Which will burn more brightly when they are connected (1) In series (2) In parallel across 220v main.

$$R_{40} > R_{60} > R_{100}$$

Brightness depends on power dissipation,

- (1) In series

$$P=I^2R, I \text{ constant}$$

$P \propto R$ Higher the resistance higher the power dissipation. So 40w bulb burns most brightly.

- (1) In parallel $P = \frac{V^2}{R}$, V - Constant . $P \propto \frac{1}{R}$, lower the resistance higher the power dissipation.
So 100w bulb burns most brightly.

Chapter 3

MOVING CHARGES AND MAGNETISM

Introduction

In 1820 Hans Christian Oersted noticed that a current carrying conducting wire create a magnetic field around the wire.

His experimental observations are,

1. Alignment of the magnetic compass needle tangent to an imaginary circle around the current carrying wire at its centre.
2. By reversing the direction of current the orientation of the needle also reverses.
3. Deflection of the needle depends upon the strength of the current through the wire.
(Increases with increasing current)

Conclusion

Moving charges or Current produces a magnetic field in its surrounding space.

Note

1. Charges at rest produces electric field only.
 2. Charges in motion produces both magnetic field as well as electric field.
- What is the Lorentz Force?
A point charge 'q' moving with a velocity \vec{v} in a magnetic field \vec{B} experiences a force on it.
It is given by, $\vec{F} = q(\vec{v} \times \vec{B})$
ie, $\vec{F} = qVB \sin \theta \hat{n}$
Where ' θ ' is the angle between velocity vector and the magnetic field vector.

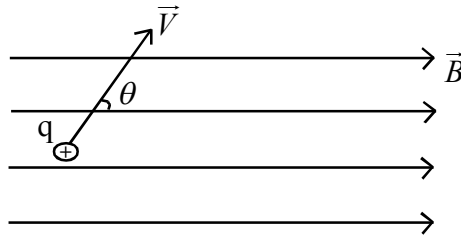

The direction of the force experienced is obtained by right hand screw rule. -

Curl the fingers of the right hand from \vec{v} to \vec{B} , the direction of extended thumb gives the direction of Lorentz force.

Note

1. If the charge is negative, the force experienced is opposite to that of the +ve charge.
2. The force experienced by the charge q is 'Zero' when,
 - a) \vec{v} and \vec{B} are parallel or antiparallel
ie, $\theta = 0^\circ$ or $\theta = 180^\circ$ ($\sin 0 = 0$, $\sin 180 = 0$)
 - b) $|\vec{v}| = 0$
 - c) The particle is neutral

3. Force on the charge is maximum for the given $|\vec{v}|$ and $|\vec{B}|$

When,

a) \vec{v} is perpendicular to \vec{B} . ie, when $\theta = 90^\circ$ ($\sin 90^\circ = 1$)

State Direction of Lorentz Force

The direction of the Lorentz force is perpendicular to both \vec{v} and \vec{B} and is obtained by right hand screw rule or right hand rule.

Features of Magnetic Lorentz Force

- ◆ Magnetic Lorentz force does no work on the charged particle, because it is perpendicular to \vec{v} and \vec{B} .
- ◆ Magnetic Lorentz force does not change the kinetic energy of the charged particle.
- ◆ Magnetic Lorentz force changes the momentum of the charge particle.

Magnetic Force On a Current Carrying Conductor in a magnetic field

Find the equation for magnetic force on current carrying conductor.

A straight conductor of length 'l' area of cross section 'A' carrying a current 'i' ampere is placed in a magnetic field \vec{B} .

Let 'e' be the charge of an electron (current carrier)

Let No. of electrons/unit volume = n

Volume of the conductor = $A\ell$

∴ No. of electrons in the conductor = $nA\ell$

Amount of charge conducting per unit time

$$q = neA\ell$$

This charge is drifting with a velocity \vec{v} .

Then the force on the conductor. (by using Lorentz force)

$$* \quad \vec{F} = qVB \sin\theta \hat{n}$$

$$|\vec{F}| = qVB \sin\theta$$

Substituting $q = neA\ell$

$$|\vec{F}| = neA\ell VB \sin\theta$$

$$neAV = i \left[V = \frac{l}{t} \therefore \frac{neAl}{t} \text{ which is } \frac{q}{t}, i = \frac{q}{t} \right] \text{ (Charge per unit time)}$$

$$|\vec{F}| = iB\ell \sin\theta$$

$$\text{ie, } \vec{F} = i(\vec{l} \times \vec{B})$$

Magnitude of Force on the current carrying conductor.

$$F = Bil \sin\theta$$

Force is maximum when $\theta = 90^\circ$

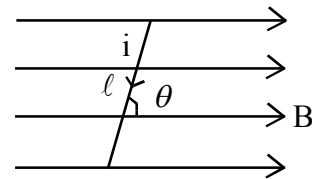

$$F = BIl \sin 90^\circ$$

$$F = BIl$$

The direction of force is given by Fleming's left hand rule - stretch mid finger, forefinger and thumb of the left hand in three mutually perpendicular directions. Mid finger indicates direction of current, Forefinger indicates direction of magnetic field then thumb will indicate the direction of force.

Question

- ◆ A current carrying straight wire is aligned in N.S direction. What is the force on the conductor.
 - a) Zero b) $Bi \sin \theta$ c) Bi
- ◆ A current straight wire is aligned in E-W direction. What is the force on the conductor.
 - a) Zero b) $Bi \sin \theta$ c) Bi

Explain Motion of a charged particle in a magnetic field

- ◆ A charged particle is travelling with velocity \vec{v} parallel to the field \vec{B} , the trajectory is a straight line because the magnetic lorenz force is zero.
 - Same is the result when the particle is antiparallel to \vec{B} .
- ◆ If \vec{v} is perpendicular to \vec{B} , the magnetic lorenz force is perpendicular to both \vec{v} and \vec{B} . It provides necessary centrepetal force and the trajectory is a circle.

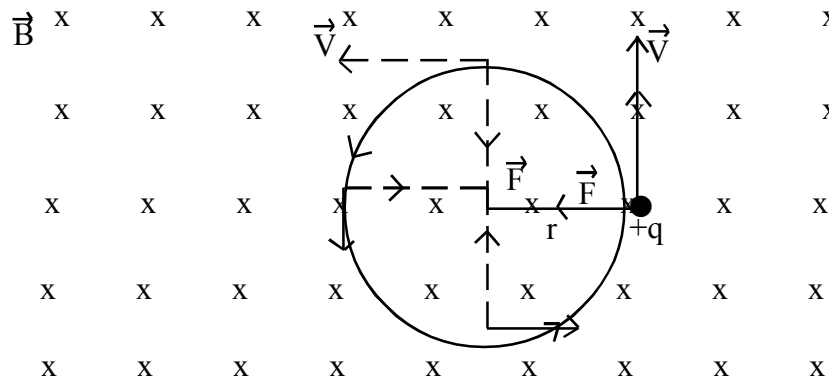

$$\text{Centrepetal force} = \frac{mV^2}{R}$$

$$\text{Lorenz force} = qVB$$

Both are the same since the lorenz force is acting as the centrepetal force.

$$\frac{mV^2}{R} = qVB$$

$$\therefore V = \frac{qBR}{m}$$

From the equation; We obtain

$$\therefore V \propto R, \text{ for constant 'B' and 'q/m'}$$

$V=Rw$ Where w - angular velocity.

$$\therefore R\omega = \frac{qBR}{m}$$

$$\therefore \omega = \frac{qB}{m}, \quad \omega = 2\pi\nu$$

ν is the frequency.

$$\therefore 2\pi\nu = \frac{qB}{m} \quad \therefore \nu = \frac{qB}{2\pi m}$$

This frequency called cyclotron frequency.

Cyclotron

What is cyclotron

Cyclotron is a particle accelerator - used to accelerate charged particle to a very high speed (KE)

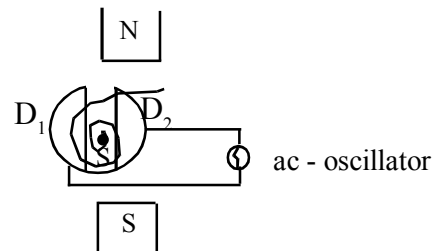

Who invented cyclotron

E.O. Lawrence and M.S. Livingston in 1934.

Explain the Principle of cyclotron

In a cyclotron, charged particle is made to move in a circular path using magnetic field and is accelerated using electric field.

(Motion of the charged particle is a crossed electric and magnetic field)

Construction and working of cyclotron

Cyclotron consist of two semicircular hollow metallic cylinders called dees, D_1, D_2 these Dees are arranged such that their surface is perpendicular to the magnetic field. The dees are connected to an ac oscillator that provides a constant alternating electric field which is perpendicular to the magnetic field.

Working

The charged particle (s) that is to be accelerated is placed in the gap between the dees.

As the particle moves from one dee towards the other, the polarity of the dees should be changed. This can be done by ac oscillator.

At the gap between the dees, the particle is accelerated by means of suitable electric field.

The frequency of the ac oscillator is adjusted with the cyclotron frequency of the particle.

(precaution of cyclotron)

$$\nu = \frac{qB}{2\pi m}$$

KE of the particle ejected from the cyclotron in a cyclotron, (Speed \propto radius of the path $V \propto R$)

For maximum speed of the particle.

$V(\text{max}) \propto R$, where 'R' is the radius of the dees.

$$V_{(\text{max})} = \frac{qBR}{m}$$

$$KE_{(\text{max})} = \frac{1}{2} m (V_{\text{max}})^2 = \frac{q^2 B^2 R^2}{2m} \quad \text{OR} \quad KE_{(\text{max})} = 2\pi^2 \nu^2 m R^2$$

$$\text{But } qB = 2\pi\nu m$$

Question

- Is it possible to accelerate a particle like electron using cyclotron? Why?
No, Due to relativistic effect, the mass of the particle increases with speed. The electron has got negligibly small mass and so the relativistic effect on an electron is more and there is frequent change in the cyclotron frequency which is dependent on mass of the particle to be accelerated.

Limitation of cyclotron

Due to the relativistic effect, the mass of the particle being accelerated increases with speed. Therefore cyclotron frequency constantly changes and hence it is difficult to synchronise with the frequency of the ac oscillator.

Questions

- Explain the construction of a cyclotron
- Explain the working principle of cyclotron
- What is cyclotron frequency

Note : Cyclotron frequency

The Frequency at which a charged particle undergoes circular motion in a perpendicular ($\perp r$) magnetic field \vec{B} .

$$\nu \propto \left(\frac{q}{m}\right) \text{ (Charge to mass ratio of the particle)}$$

ν is independent of the particle speed V .

Question

A proton, deuteron and α - particle are entering in a uniform \vec{B} with same speed transverse to \vec{B} direction. Which particle circulate in the field with more frequency and more radius.

$$i) \quad R \propto \frac{1}{\left(\frac{q}{m}\right)},$$

α - particle of least $\left(\frac{q}{m}\right)$, hence it traces with circular path more radius.

$$ii. \quad \nu \left(\frac{q}{m}\right) \text{ electrons has more } \left(\frac{q}{m}\right) \text{ and have more frequency.}$$

Note: If the charge entered with velocity \vec{v} in a uniform magnetic field \vec{B} making an angle θ , the path of the charged particle is helical.

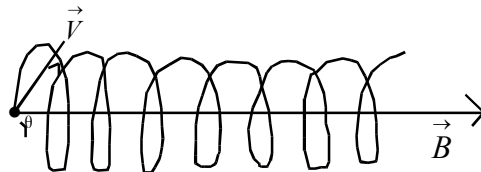

Total Lorentz force

The electric force on a charged particle of charge 'q' in a uniform \vec{E} is given by $\vec{F}_e = q\vec{E}$

Magnetic force on the charge in a uniform magnetic field is given by

$$\vec{F}_m = q(\vec{V} \times \vec{B})$$

The total force on the charge in a perpendicular \vec{E} and \vec{B} is given by

$$\vec{F} = q\vec{E} + q(\vec{V} \times \vec{B})$$

This is called total Lorentz force.

Note

A charged particle of charge 'q' undergoes an undeflected path in a perpendicular electric and magnetic field, then $\vec{F} = 0$

$$qE = qVB$$

$$V = \frac{E}{B}$$

Where V is the speed.

This condition can be used to select charged particles of particular velocity out from a beam containing charges moving with different velocities.

This condition is used in velocity selector.

Note :

- i. This method is used by JJ Thomson to determine the charge to mass ratio of electron ($\frac{e}{m}$).
- ii. This principle is also used in mass spectrometer used to separate charged particles according to their $\frac{e}{m}$ ratio.

Biot - Savart Law

What is current element?

An infinitesimally small current carrying segment is called current element.

State Biot - savart law

Consider a current carrying conductor xy carrying current 'i' ampere. AB is a small current element of length dl, The Magnetic field at a point 'p' due to this current element is given by \vec{dB} .

Biot - savart law states that; the magnetic field.

- i) dB is proportional to the strength of the current.
- ii) dB is proportional to the length of the current element.
- iii) dB is proportional to $\sin \theta$
- iv) dB is inversely proportional to the square of the distance of that point from the current element

$$\Rightarrow dB \propto \frac{idlR \sin \theta}{r^2}$$

$$dB = \frac{kidl \sin \theta}{r^2} \text{ where } k = \frac{\mu_0}{4\pi}$$

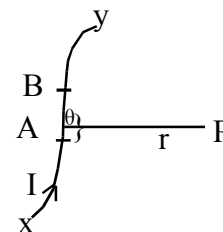

$$= 4\pi \times 10^{-7} \frac{NS^2}{C^2} \quad \mu_0 \text{ is called as the permeability of free space.}$$

Note :

Biot savart law when expressed in vector form.

$$\vec{dB} = \frac{\mu_0}{4\pi} \frac{id\vec{\ell} \times \hat{r}}{r^2}$$

$$\vec{dB} = \frac{\mu_0}{4\pi} \frac{id\vec{\ell} \times \hat{r}}{r^3}$$

Questions

A point P is at a distance 'r' perpendicular to current element

- a. Write the expression for magnetic field at P

$$\vec{dB} = \frac{\mu_0}{4\pi} \frac{id\ell \sin 90^\circ}{r^2}$$

$$\Rightarrow \vec{dB} = \frac{\mu_0}{4\pi} \frac{id\ell}{r^2}$$

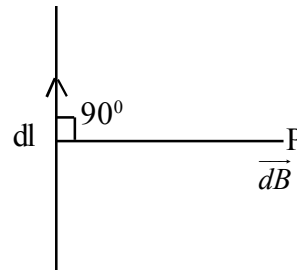

- b. How to find the direction of \vec{dB}

Right hand screw rule. Rotate a right hand screw from \vec{idl} to \vec{r} the tip of the screw advances gives direction of \vec{dB}

Application of Biot - savart law

Magnetic field at the centre of the circular coil carrying current i .

Consider a circular coil of radius R carrying a current i

$$dB = \frac{\mu_0}{4\pi} \frac{idl \sin \theta}{r^2} \quad \theta = 90^\circ, \sin 90^\circ = 1$$

$$dB = \frac{\mu_0}{4\pi} \frac{idl \sin \theta}{R^2} \quad r = R$$

$$dB = \frac{\mu_0}{4\pi} \frac{idl}{R^2} \dots \dots \dots (1)$$

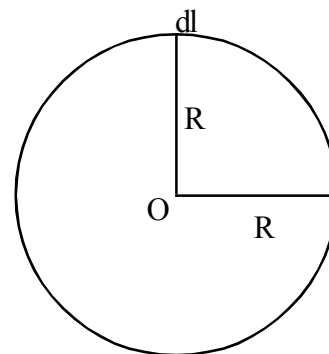

Total magnetic field at the centre can be found by integrating the expression (1).

$$\Rightarrow B = \frac{\mu_0 i}{4\pi R^2} \int dl \qquad \int dl = 2\pi R (\text{circumference})$$

$$B = \frac{\mu_0 i 2\pi R}{4\pi R^2}$$

$$B = \frac{\mu_0 i}{2R}$$

Direction of the magnetic field at the centre.

By right hand thumb rule.

Curl the palm of the right hand such that the curled fingers are in the direction of the current through the coil, then the extended thumb gives the direction of \vec{B}

I in anticlockwise direction

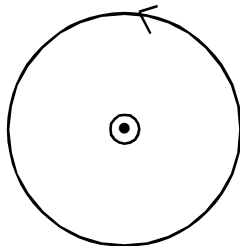

\vec{B} outwards

in clockwise direction

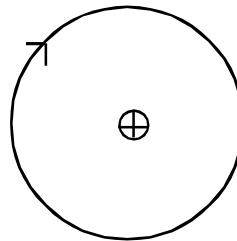

\vec{B} Inwards

Question

Is the field uniform inside the coil.

No, It is maximum at the centre and decreases towards the periphery of the coil.

Magnetic field at any point along the axis of circular coil carrying current.

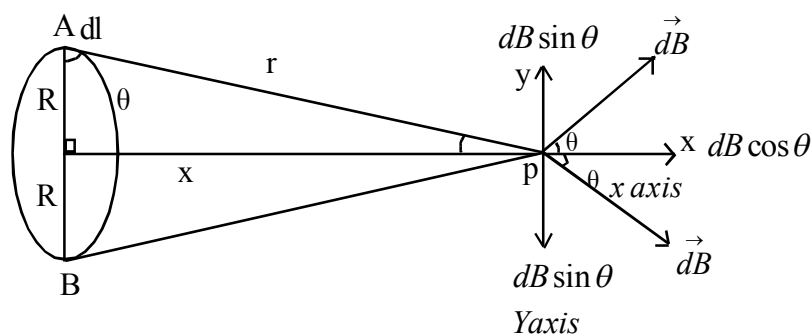

Consider a coil of radius R carrying current i ampere in the anticlockwise direction

A and B are two current elements of length dl at the diametrically opposite edges of the coil.

Magnetic field at P due to A

$$dB = \frac{\mu_0 i dl}{4\pi r^2}$$

Resolving dB at P into 2 components

$dB \cos \theta$ and $dB \sin \theta$ along x and y axis respectively.

$dB \sin \theta$ components, being equal in magnitude and in opposite direction cancel out.

Magnetic field at P is $dB^1 = dB \cos \theta$

$$\text{i.e } dB = \frac{\mu_0 i dl}{4\pi r^2} \cos \theta$$

$$r = \sqrt{x^2 + R^2}$$

$$\cos \theta = \frac{R}{r} \Rightarrow \cos \theta = \frac{R}{\sqrt{x^2 + R^2}}$$

$$r = \sqrt{x^2 + R^2} \text{ or } (x^2 + R^2)^{1/2}$$

$$\Rightarrow dB^1 = \frac{\mu_0 i dl}{4\pi (x^2 + R^2)} \times \frac{R}{(x^2 + R^2)^{1/2}}$$

$$\Rightarrow dB^1 = \frac{\mu_0 i dl R}{4\pi (x^2 + R^2)^{3/2}}$$

Total magnetic field B^1 at P is $\int dB^1$

$$\Rightarrow B^1 = \frac{\mu_0 i R}{4\pi (x^2 + R^2)^{3/2}} \int dl$$

$$\Rightarrow B^1 = \frac{\mu_0 i \times 2\pi R}{4\pi (x^2 + R^2)^{3/2}} \quad (\int dl = 2\pi R, (\text{circumference}))$$

$$\Rightarrow B^1 = \frac{\mu_0 i R^2}{2(x^2 + R^2)^{3/2}}$$

If the coil has N turns

$$B^1 = NB^1$$

$$\Rightarrow B = \frac{\mu_0 Ni R^2}{2(x^2 + R^2)^{3/2}}$$

At the centre, $x=0$

$$\Rightarrow B^1 = \frac{\mu_0 i R^2}{2(R^2)^{3/2}}$$

$$\Rightarrow B^1 = \frac{\mu_0 i}{2R} \quad B = NB^1 = \frac{\mu_0 Ni}{2R}$$

Draw the graph showing the relation between B and x

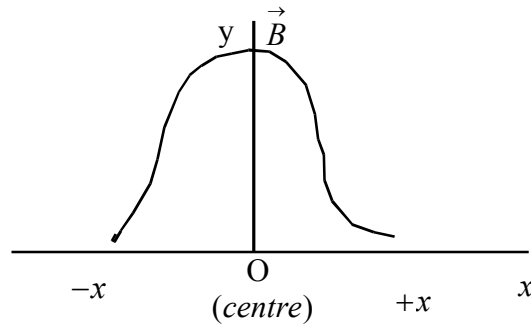

Question

A coil of length l make an angle 60° with its vertex. If it carries a current i ampere.

- a. Find the equation for magnetic field at the centre.
- b. If $i = 2A$ in anticlockwise direction find the magnitude and direction of the field at the centre.

We have ;

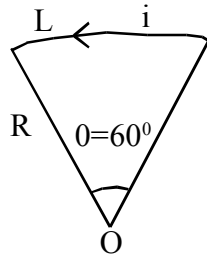

$$\theta = \frac{\text{Arc}}{\text{Radius}}$$

$$\theta = \frac{L}{R}$$

We also have $L = R\theta$ (1)

$$dB = \frac{\mu_0 i dl}{4\pi R^2}$$

$$\int dl = L$$

$$B = \frac{\mu_0 i}{4\pi R^2} \int dl$$

$$\Rightarrow \int dl = R\theta \text{ Fromk (1)}$$

$$\Rightarrow B = \frac{\mu_0 i \theta}{4\pi R}$$

$$B = \frac{\mu_0 i \theta}{4\pi R}$$

$$\theta = 60^\circ \text{ or } \frac{\pi}{3}$$

$$\Rightarrow B = \frac{\mu_0 i}{4\pi R} \times \frac{\pi}{3}$$

$$\Rightarrow B = \frac{\mu_0 i}{12R}$$

2. $i = 2A$

$$\mu_0 = 4\pi \times 10^{-7}$$

$$B = \frac{4\pi \times 2 \times 10^{-7}}{12R}$$

$$B = \frac{4\pi \times 10^{-7}}{6R}$$

$$B = \frac{2\pi \times 10^{-7}}{3R}$$

Ampere's circuital law

The line integral of the magnetic field along any closed path is equal to μ_0 times the current enclosed by the path.

$$\oint \vec{B} \cdot d\vec{l} = \mu_0 i$$

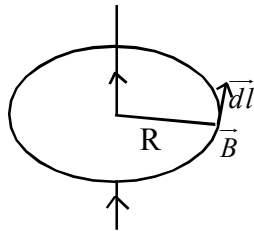

Application of Ampere circuital law

1. Magnetic field at a point due to a long straight wire. - Consider a long straight wire carrying a current i . P is point at a distance 'R' from the wire. - B - magnetic field at P.

From ampere circuited law we have

$$\oint B \cdot dl = \mu_0 i$$

Draw amperian loopat P - Here it is a circle of radius R.

Since B is constant at any point on the loop; $B \oint dl = \mu_0 i$

$$\Rightarrow B \times 2\pi R = \mu_0 i$$

$$B = \frac{\mu_0 i}{2\pi R}$$

The direction of the magnetic field is found by right hand thumb rule.

Curl the fingers of the right hand with thumb extended and hold the wire such that the thumb is along the direction of the current, then the curled fingers give the direction of the magnetic field at any point.

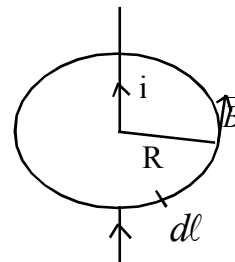

Magnetic field due to a solenoid

A conductor wound in the form of a helical spring. A short solenoid behaves as a short magnet with North pole on one side and south pole on the other side.

Polarity depends upon the current through it.

Consider an ideal solenoid (Magnetic field at a point inside the solenoid is strong and uniform, but outside is zero)

n - Number of turns/unit length, I - Current through the solenoid. p - magnetic field point.

By ampere's circuital law $\oint B dl = \mu_0 I_{\text{enclosed}} \dots\dots\dots(1)$ B - magnetic field at P .

Draw Amperian loop at P -here it is a rectangle of length ℓ number of turns of wire over the length = $n \ell$. $\therefore I_{\text{enclosed}} = n \ell I$

Eq.(1) $\Rightarrow \oint_{ABCD} B dl = \mu_0 n \ell I \dots\dots\dots(2)$

$$\oint_{ABCD} B dl = \int_{AB} B dl + \int_{BC} B dl + \int_{CD} B dl + \int_{DA} B dl$$

$$\int_{AB} B dl = B \ell \quad (\theta = 0, \ell \parallel \text{to } B)$$

$$\int_{BC} B dl = \int_{DA} B dl = 0 \quad (\theta = 90, \ell \perp \text{ to } B)$$

$$\int_{CD} B dl = 0 \quad (\text{For ideal solenoid, outside the solenoid } B=0)$$

$$\oint_{ABCD} B dl = B \ell \dots\dots\dots(3)$$

using (2) and (3),

$$B \ell = \mu_0 n \ell I$$

$$B = \mu_0 n I \quad (\text{core is air})$$

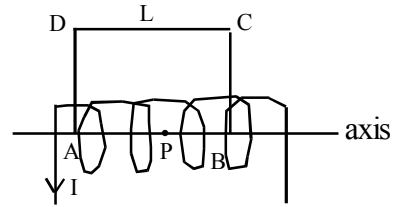

$$\int B dl = B \ell \cos \theta$$

If the core is a material of relative permeability μ_r $\mu_r \mu_0 = \frac{\mu}{\mu_0}$

$$B = \mu_0 \mu_r n I$$

3. Magnetic field due to a Toroid

Toroid - Endless current carrying solenoid.

a) Field point inside the toroid

By ampere's circuital law $\oint_1 B dl = \mu_0 I_{\text{enclosed}}$

But I_{enclosed} by the amperian loop is zero. $\therefore B = 0$

b) Field point P on the circular axis of the toroid.

By Ampere's circuital law $\oint_2 B dl = \mu_0 I_{\text{enclosed}} \dots\dots\dots(1)$

$$\oint_2 B dl = B 2\pi a \dots\dots\dots(2) \quad \text{where } a = \frac{a_1 + a_2}{2}$$

$$I_{\text{enclosed}} = n 2\pi a I \dots\dots\dots(3)$$

From Eg. (1), (2), (3) - $B 2\pi a = \mu_0 n 2\pi a I = B = \mu_0 n I$

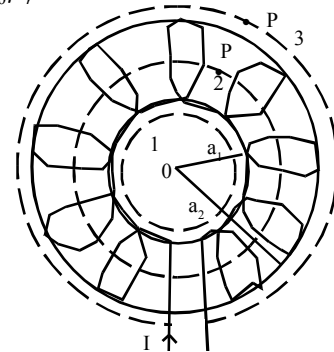

c) Field point P is outside toroid.

By ampere's circuital law $\oint B d\ell = \mu_0 I_{\text{enclosed}}$

$I_{\text{enclosed}} = 0$ Since current entering the plane of the paper is cancelled by the current leaving from the plane of the paper. $\therefore B=0$

● A Toroid has no free N - pole and south pole (its is endless)

Force between two parallel short conductors carrying currents.

By Biot-Savaret's Law

Magnetic field produced by the current element

$$I_1 d\ell_1 \text{ at } d\ell_2, dB_1 = \frac{\mu_0 I_1 d\ell_1}{4\pi r^2} (\theta = 90)$$

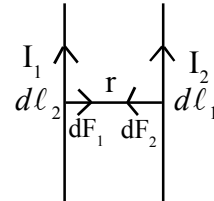

\therefore Force experienced by the current element $I_2 d\ell_2$ in this magnetic field is $dF_2 = I_2 d\ell_2 dB_1$

$$= \frac{\mu_0 I_1 I_2 d\ell_1 d\ell_2}{4\pi r^2} (\theta = 90)$$

ie, $dF_1 = \frac{-\mu_0 I_1 I_2 d\ell_1 d\ell_2}{4\pi r^2}$ (-ve sign shows direction opposite)

$\therefore dF_1 = -dF_2$, attractive

Force between parallel conductors carrying currents in the same direction (parallel currents) is attractive, it is repulsive in nature. If the currents are in the opposite directions (Anti Parallel Currents).

Qn. An over head cable carries a current of 90 A in the N-S direction. What is the magnitude of magnetic field at a distance 2cm below the wire. What is the direction which principle is used.

$$B = \frac{\mu_0 I}{2\pi r} = \frac{2 \times 10^{-7} \times 90}{2 \times 10^{-2}} = 9 \times 10^{-4} \text{ A}, \text{ towards East using right hand grip rule.}$$

* When a charged particle moves perpendicular to a magnetic field its momentum changes but its KE and speed remain constant. Because motion of a charged particle in a perpendicular magnetic field is circle.

* Torque acting on a dipole in a magnetic field is $\tau = NIAB \sin\theta$ (N-Number of turns, A-area, θ angle between m and B. $m = NIA$, Magnetic moment, Hence $\tau = mB \sin\theta$)

Moving Coil Galvanometer (MCG) - Used for the measurement of electric current & voltage.

Devised by Kelvin Principle - A current loop (Dipole) in a magnetic field experiences torque.

Ns - field magnet - produces radial magnetic field (B)

A-Copper coil of N turns and area A

Sp - Spring - Produces restoring torque.

C - Soft iron core to increase the magnetic field B. When electric current I flows through the coil deflection torque experienced by the coil $\tau_{def} = NIAB$. Restoring torque act by the spring τ_{rest}

$$= K\theta \text{ (Since B parallel to the plane of the coil)}$$

Where θ is the angle through which the coil rotates.

K - Torsional constant of the spring. At equilibrium $\tau_{def} = \tau_{rest}$. The coil does not rotate.

$$NIAB = \theta$$

$$I = \left(\frac{K}{NAB} \right) \theta$$

$I \propto \theta$, working principle of MCG

- * Pole pieces are cylindrical in shape - To produce radial magnetic field.

- * Current sensitiveness of MCG -

The deflection in a galvanometer per unit current, $\theta/I = \frac{NAB}{K}$

- * How can increase the sensitiveness of MCG : Increase N, B, A and decrease K.

- * Voltage sensitiveness of MCG - The deflection in a Galvanometer per unit voltage

$$\theta/V = \frac{\theta}{IR_g} = \frac{NAB}{KR_g}$$

where R_g - Resistance of Galvanometer coil.

- * Increase in current sensitivity by doubling number of turns may not increase voltage sensitivity - Justify.

$$\frac{\theta}{I} = \frac{NAB}{K}$$

$$\text{If } N \Rightarrow 2N, \quad (\theta/I)' = 2 \cdot \frac{\theta}{I}$$

But $R_g \Rightarrow 2R_g$ (Since $R \propto l$)

$$\theta/V = 2 \frac{\theta}{I \cdot 2R_g} \Rightarrow \frac{\theta}{IR_g}$$

- * Resistance of Milli Ammeter is greater than resistance of Ammeter - To measure small current greater is the sensitivity of MCG. To increase the sensitivity increase the number of turns (N). This will increase the resistance of Milli Ammeter Since $R \propto l$.

- * Figure of merit - Minimum current required to produce a deflection of I_{div} on a galvanometer. $I \propto \theta$, then $I = K\theta$, $K = \frac{I}{\theta}$, Figure of merit.

- * Smaller the figure of merit greater is the sensitivity.

- * A Galvanometer cannot as such is used as an ammeter to measure the current.

(i) Due to small resistance and high sensitivity

(ii) When it is connected to a circuit this will change the value of current because it has a resistance.

- * Conversion of Galvanometer into Ammeter.

A Low resistance (or shunt resistance) connected in parallel to Galvanometer.

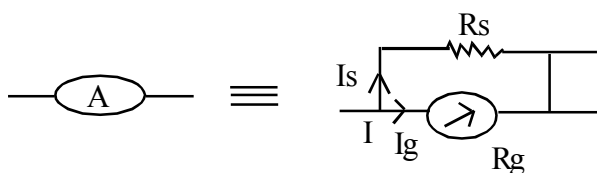
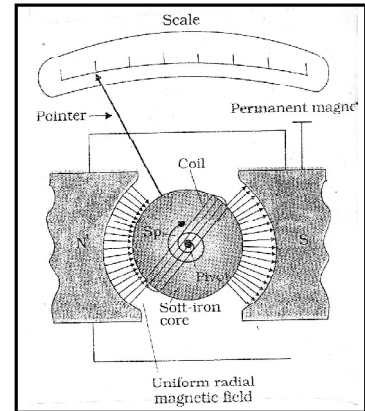

- R_s - Shunt resistance
- R_g - Galvanometer resistance
- I_g - Current for full scale deflection in Galvanometer.

- * Resistance of Ammeter (R) Since R_s and R_g are in parallel

$$\frac{1}{R_{eff}} = \frac{1}{R_s} + \frac{1}{R_g}$$

$$R_{eff} = \frac{R_s R_g}{R_s + R_g} \ll R_g \text{ of } R_s < R_g$$

- * Ammeter has very low resistance. So it is connected in series with an electrical circuit to measure the current in the circuit.

- * Expression for shunt resistance used

$$P.d(R_s) = P.d(R_g)$$

$$I_s R_s = I_g R_g$$

$$R_s = \frac{I_g R_g}{I_s} \quad I = I_s + I_g$$

$$R_s = \frac{I_g R_g}{(I - I_s)}$$

- * Conversion of Galvanometer into voltmeter.

A high resistance is connected in series with Galvanometer.

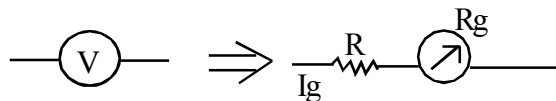

- * Resistance of voltmeter: Since R and R_g are in series.

Resistance of voltmeter $R_{eff} = R + R_g$

- * Voltmeter has very high resistance so it is connected in parallel to a circuit to measure voltage.

Chapter 4

MAGNETISM AND MATTER

Magnetism and Matter

- * Magnetism is the proper of moving electric charge.

Qn. Difference between electricity and magnetism?

In electricity isolated electric charge exists. In magnetism isolated magnetic poles do not exist.

- * Is magnetic pole required for producing magnetic field?

No. magnetic field is produced by a current carrying conductor.

- * Properties of a magnet (a) Attraction and repulsion (b) Magnetic length is less than its Geometric length (c) Directive property d) Isolated magnetic poles do not exist.

- * Magnetic potential energy - work done to turn a magnet in magnetic field.

$$w = \int \tau d\theta = \int mB \sin\theta d\theta = -mB \cos\theta$$

$$U = -m \cdot B$$

Case (i) $\theta = 0$ $U = -mB$, minimum - stable state

(ii) $\theta = 90$ $U = 0$

(iii) $\theta = 180$, $U = mB$, maximum - unstable state

- * Gauss's Theorem in magnetism - The surface integral of magnetic field over a closed surface is Zero.

$$\oint B ds = 0$$

- * Gauss's Theorem establishes that isolated magnetic poles do not exist.

Gauss's Theorem in electrostatics $\oint_s E \cdot ds = \frac{q}{\epsilon_0}$

For an electric dipole net charge $q=0$ (Since it has equal and opposite charges)

$$\text{So } \oint_{\text{for dipole}} E \cdot ds = 0$$

Similarly $\oint_{\text{for dipole}} B \cdot ds = 0$ says a dipole has North (N) and South (S) poles.

- * What are the magnetic properties of a material Intensity of magnetisation(M). The extent to which a material is magnetised.

Magnetic intensity (H) - Ability of a magnetising field to magnetise a material.

Magnetic susceptibility (X_m)- Ability of a material to become a magnet.

Magnetic Permiability (μ) - Ability of a material to transmit magnetic field lines.

- * Relation between magnetic susceptibility and magnetic permiability, $\mu_r = 1 + X_m$

- * Air is not responding to external magnetic field - Because susceptibility of air is zero.

- * Classification of magnetic materials - Faraday Classified

Properties	Diamagnetic	Paramagnetic	Ferro magnetic
1. Intensity of magnetisation	Feebly magnetised in the direction opposite to the magnetising field	Feebly magnetised in the direction of magnetising field.	Strongly magnetic in the direction of magnetising field.
2. Magnetic susceptibility	Small and -ve	Small and +ve	High and +ve
3. Magnetic Permiability	<1	>1	Very high
4. Dipolemoment	Zero	Non Zero	Non Zero
5. Examples	Bi, Cu, Pb, Au, Ag, Hg	Al, Cr, Ca, Na, Mg,	Fe, Co, Ni, Steel

* All the materials exhibit diamagnetic property

* Behaviour of dia, para and Ferromagnetic material in a magnetic field.

Note: Magnetising field
- Magnetic field used for induced magnetism

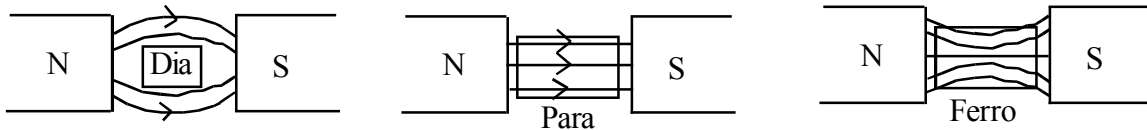

* Core of a solenoid is used as Bismath - write your opinion. Bismath is diamagnetic and field will be less inside the solenoid but it is greater outside the solenoid.

* Magnetic Hysterisis : The laging of induced magnetic field behind the magnetising field.

* Define Retentivity - The residual induced magnetism in a material even when the magnetising field is reduced to Zero.

* Coercivity - The reverse magnetising field is required to damagnetise a material.

* Hysterisis loss - Energy loss per unit volume when a magnetic material undergoes a cycle of magnetisation. It is given by area under the hysteresis curve greater the area greater in the hysteresis loss.

* Core of dynamo, Transformer made of soft iron not steel - Hysterisis loss is minimum.

* One of the reason for the magnetic field of earth - electric current produced by molten metallic fluids, mainly iron and nickel, with in its interior called Dynamo effect.

* Magnetic elements of earth - The quantities which describe the magnetic field of earth.

(1) Declination (2) Inclination (dip) (3) Horizontal intensity.

* Dipangle is Zero at equator and 90 at poles.

* At the poles of earth magnetic instruments do not work - Horizontal intensity of earth's magnetic field in zero.

* Dip needle - Compass needle, which is used to find the direction at the pole.

* Horizontal intensity of Earth's magnetic field (H_E) = $0.38 \times 10^{-4} T$.

* Earth's core contan Iron yet Geologists do not regard this as source of earths magnetism - In the molten state Iron is not ferromagnetic.

* Why soft iron is preferred morethan steel for making electromagnet. It has high permiability suceptibility low coercivity.

* Explanation of Hysterisis curve of Ferromagnetic (Fe, Co, Ni)

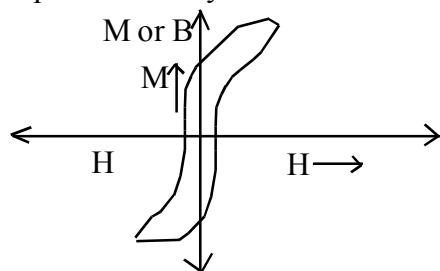

* It has large induced magnetism for small value of H.

* It has large μ_r and x_m (slope of the graph indicates).

* It has low coercivity.

* Low hysteresis loss.

Note : Soft iron has low retentivity, but graph only indicates large induced magnetism for small magnetising field.

Chapter 5

ELECTROMAGNETIC INDUCTION

Michel Faraday and Joseph Henry demonstrated that a moving magnetic field (changing magnetic flux) can produce emf and hence electric current.

Experiments:

- 1) **Coil-Magnet experiment** - Galvanometer show deflection when N-pole moving towards the coil. It shows deflection in the opposite direction if the pole is moving away from the coil. It shows Zero deflection when the magnet is kept stationary inside the coil.
Thus an emf hence electric current is induced in the coil due to the relative motion of the magnet.
(Source of Magnetic field)

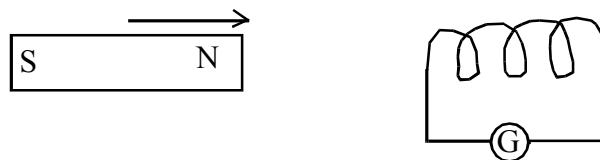

- 2) **Coil - Coil experiment**

By making and breaking the current through the coil 1, an emf and hence electric current is induced in the coil 2.

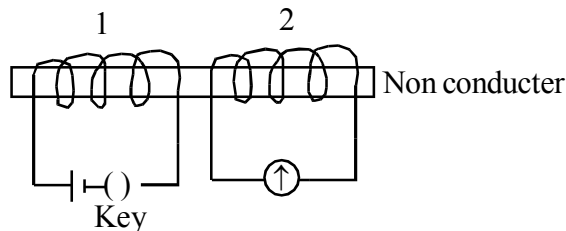

- **Electromagnetic Induction** : The process of inducing emf and hence electric current as a result of change in magnetic field or magnetic flux linked with a conductor.

- **Laws of electromagnetic Induction :**

- i) **Faraday's Rule or Flux Rule** : When magnetic flux linked with a conductor changes there will be an induced emf

The induced emf is directly proportional to the rate of change of magnetic flux (ϕ_B)

$$\text{Induced emf} \propto \frac{d\phi_B}{dt}$$

- ii) **Lenz's Rule** : The direction of induced emf and hence induced current is such that it opposes the change in magnetic flux which is responsible for induced emf.

$$e = \frac{-d\phi_B}{dt}, \text{ -ve sign shows } e \text{ opposes } \phi_B$$

It is the consequence of Law of conservation of energy.

- Lenz's Rule and Conservation of energy :**

In fig (1) in order to move the magnet towards the coil work has to be done against the force of repulsion in fig. (2). In order to move the magnet away from the coil work has to be done against the force of attraction.

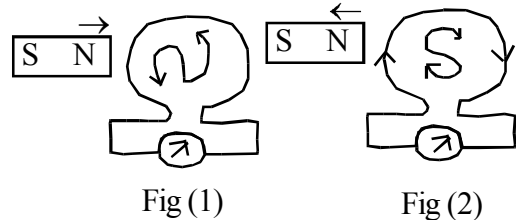

This work appears in the coil as emf. Hence energy is therefore conserved.

- A bar magnet is accelerated through a coil with its length parallel to the axis of the coil as shown what is the relation between a and g, in fig (1) and (2).

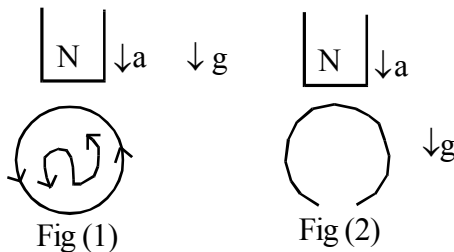

(Note : Direction of induced current - clock wise (S) - Induces S - Pole. Anti clockwise (N) - Induces - N Pole)

In fig (1), $a < g$, since magnet experiences force of repulsion.

In fig (2), $a = g$, since there is no current is flowing, Because curcuit is open.

- Predict the polarity of the capacitor.

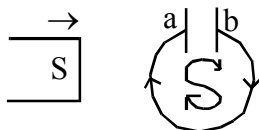

Plate a is +ve (current entering)

Plate b is -ve (current leaving)

- A conductor of length ℓ is moving with a velocity v in a perpendicular magnetic field B , emf induced in the conductor $e = B\ell v$. emf induced is called motion at emf.

- An aeroplane with wing span of 25m flies at a horizontal speed of 1800 km/h at a place where the magnetic field of earth is 5G and dip angle is 30° . What is Potential difference between the tip fo the wing.

Induced emf $e = B_v \ell v$, where $B_v = B \sin \theta = 5 \sin 30 = 2.5 \times 10^{-4} T$

$$\therefore e = 2.5 \times 10^{-4} \times 25 \times \frac{1800 \times 10^{-3}}{60 \times 60} = 3.13 V$$

- Magnetic Lorenz force is the reason for Electro-magnetic induction.

Note: B-magnetic field of earth
 δ -dip angle
 $B_v = B \sin \delta$, Vertical component
 $B_H = B \cos \delta$, Horizontal Component

- The magnetic flux passing perpendicular to the plane of a coil is varying according to the relation $\phi_B = 6t^2 + 7t + 1$ What is the magnitude of emf induced in the loop when $t=2s$. ϕ_B is in mwb.

$$|e| = \frac{d\phi_B}{dt}, \quad |e| = \frac{d}{dt}(6t^2 + 7t + 1) = 12t + 7$$

$$\text{When } t = 2s \quad e = 24 + 7 = 31 \text{ mv}$$

- Eddy Current (Foucault's Current):**

When a non magnetic metallic block (Cu/Al) is placed in a varying magnetic field or moves in a magnetic field, induced circular current setup inside the block due to electromagnetic induction. Such currents are called Eddy Currents.

- Demonstration -**

Metallic Block moves up and down due to eddy current in accordance with Lenz's Rule.

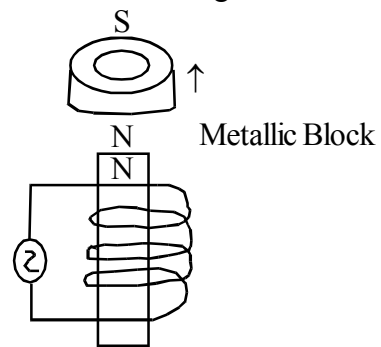

- Demerit -**

Eddy current results in wastage of energy in the form of heat.

- The slots cut across the block reduces induced Eddy Current. (Area available for the flow of eddy current decreased)

- The metal block is laminated and insulated from each other reduces induced Eddy current (increase the resistance to the flow of eddy current)

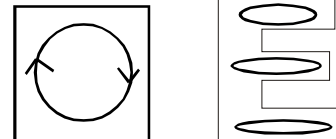

Difference between metal block and slots cut metal block.

- To minimise the energy loss due to eddy current the core of dynamo and transformer are made of slots cut thin sheets of iron insulated from each other.

- Practical uses of Eddy current - speedometer, Induction oven, Breaking system in modern trains, Dead beat galvanometer.

- Inductance** - Electrical property of a conductor by which it opposes the growth or decay of current through it.

ϕ_B - Magnetic flux linked with the coil.

I - Current, Then $\phi_B \propto I$

$$\phi_B = LI$$

L - Inductance of the coil. Its unit is Henry (H)

But $|e| = \frac{d\phi_B}{dt}$ induced emf $e = L \frac{dI}{dt}$

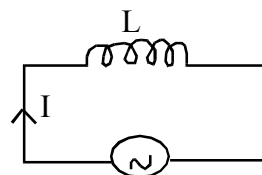

- Expression for inductance of a solenoid**

Let l - length, A - area cross section, n - number of turns / unit length, I - current.

Magnetic field inside the solenoid, $B = \mu_0 nI$

Magnetic flux each turn of the solenoid $d\phi_B = BA$

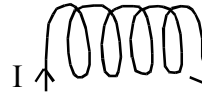

$$= B = \mu_0 nI$$

Note : $\phi_B = BA \cos \theta$

$$\theta = 0$$

Total number of turns in the solenoid, $N = n\ell$.

Therefore Total flux linked with the solenoid $\phi_B = N(d\phi_B)$

$$\phi_B = n\ell\mu_0 nIA$$

$$\text{Induced emf } e = \frac{d\phi_B}{dt} = n^2 I \mu_0 A \frac{dI}{dt} \dots\dots\dots (1)$$

If L is the inductance of the solenoid

$$e = \frac{-LdI}{dt} \dots\dots\dots (2)$$

Note : $\phi_B = LI$ $e = \frac{d\phi_B}{dt}$

From equations (1) and (2),

$$L = \frac{dI}{dt} = \mu_0 n^2 A \ell \frac{dI}{dt}$$

$$L = \mu_0 n^2 A \ell$$

$$= \frac{\mu_0 N^2 A}{\ell}$$

i.e., Inductance depends on (1) size (l) and shape (A) of the coil (Geometry of the Coil) (2) Number of turns (N).

If the core is filled with a material of relative permeability, μ_r , $L = \frac{\mu_0 \mu_r N^2 A}{\ell}$

- Choke Coil : Inductance coil having large number of turns and made of thick copper wire of small resistance/used to control AC through a Circuit without loss of energy.

- Sparks are produced across the switch when light is switched off - large induced emf is produced due to self induction.

- Expression for energy stored in an inductor.

Let I be the current through the inductor L at a certain time t

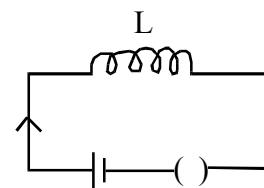

during the growth of current from 0 to max (I_0).

then $\phi_B = LI$

Back emf induced $e = \frac{LdI}{dt}$

Note : $\int IdI = \frac{I^2}{2}$

Work done by the source $dw = eIdt$
 $LIdI$

\therefore Total work done $W = \int_0^{I_0} dw$

$$W = \frac{LI_0^2}{2}$$

This work is stored as energy $u = \frac{1}{2}LI_0^2$, in the form of magnetic field.

- Self inductance plays the role of inertia in a coil.
- **Mutual Induction** : When electric current flowing through a coil (P) changes, the magnetic flux linked with the neighbouring coil (ϕ_B) changes which induces an emf and hence current in the neighbouring coil.

I - Current through P.

ϕ_B Magnetic flux linked with Q

$\phi_B \propto I$

$\phi_B = MI$ where I - Mutual inductance of the coil Q.

But $|e| = \frac{d\phi_B}{dt}$

Induced emf $e = \frac{M.dI}{dt}$

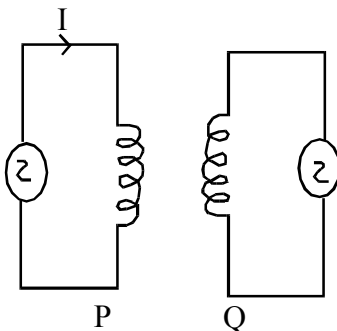

-

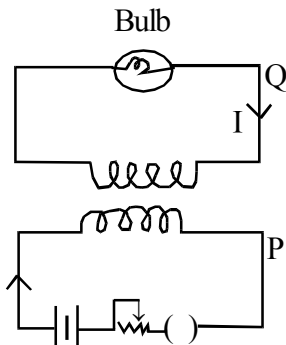

(i) What do you observe when Key K is (1) just closed (2) Being closed (3) Just opened coil P. Why?

a) Bulb glows, Magnetic flux linked with the coil Q changes an emf is induced.

b) Bulb does glow. There is no change in flux. Hence no emf.

(ii) What is the phenomenon called - Mutual Induction.

- (iii) How can you increase the brightness of the bulb in the coil Q.
 Increase the number of turns in the coil Q.
- (iv) Can you name an instrument which works on this principle - Transformer.
- Applications of electromagnetic Induction -
 (1) AC generator (2) Transformer.

AC Generator : Converts Mechanical energy into Electrical energy.

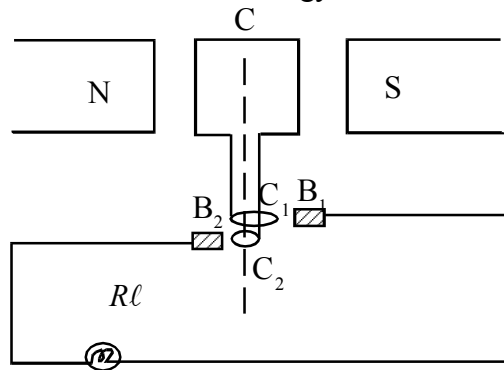

NS - Field Magnet - used for producing magnetic field, usually electromagnet.

C - Armature Coil - Insulated copper wire wound over an iron drum.

$C_1 C_2$ - Slip Rings, $B_1 B_2$ - Graphite brushes. R_l - Bulb. (Load resistance)

When armature coil rotates in the Magnetic field B, the magnetic flux linked with the coil changes.

So an emf and hence current is induced in the coil due to electromagnetic induction.

N - Number of turns in the armature coil.

A - Area of the coil.

B - Magnetic field produced by the field magnet.

Total Magnetic flux linked with the coil $\phi_B = N(B \cdot A)$.

$$= NBA \cos \theta$$

where θ is the angle between B and A (Area Vector)

If the coil rotates with an angular velocity ω , at a particular time t, $\theta = \omega t$.

$$\text{Then } \phi_B = NAB \cos \omega t.$$

By laws of electromagnetic induction,

$$\text{Induced emf, } e = \frac{d\phi_B}{dt}$$

$$e = NAB\omega \sin \omega t, \text{ Instantaneous emf.}$$

$$e = V_0 \sin \omega t \text{ ----- (1) where } V_0 = NAB\omega - \text{Amplitude of emf.}$$

If R is the resistance of the armature coil.

$$\text{Induced current, } I = \frac{e}{R}$$

$$I = \frac{e_0}{R} \sin \omega t$$

$$I = I_0 \sin \omega t \text{ ----- (2) where } I_0 = \frac{V_0}{R} = \frac{NAB\omega}{R} \text{ Amplitude of current.}$$

Chapter - 6

ALTERNATING CURRENT

A simple type of ac is one which varies with time in simple harmonic manner- Represented by sine curve.

ac voltage $V = V_0 \sin \omega t$ - Where $V_0 = NAB\omega$ Amplitude and $\omega = 2\pi v$

ac current $I = I_0 \sin \omega t$ Where $I_0 = \frac{NAB\omega}{R}$, Amplitude

ac - Time depend emf current
dc - Time independent emf current

What are the advantages of AC

- 1) Easily stepped up or stepped down using transformer
- 2) Can be regulated using choke coil without loss of energy
- 3) Easily converted into dc using rectifier (Pn - diode)
- 4) Can be transmitted over distant places
- 5) Production of ac is more economical

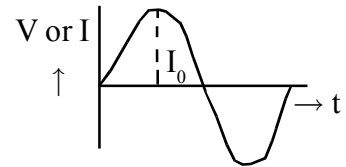

VI relation for Resistor, Inductor and capacitor

For resistor $V=IR$ Inductor $V = L \frac{dI}{dt}$ capacitor $I = C \frac{dv}{dt}$

Note :
 $Q = CV$
 $\frac{dQ}{dt} = C \frac{dv}{dt}$
 $I = C \frac{dv}{dt}$

What is AC circuit Electrical circuit to which ac voltage is applied

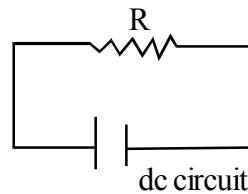
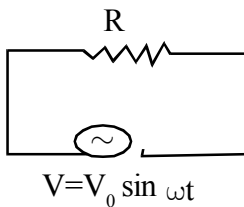

What is Phasor (Rotating Vector)

To study ac circuit alternating voltage and current in a circuit can be treated as phasor.

(Note : Voltage and current are scalars)

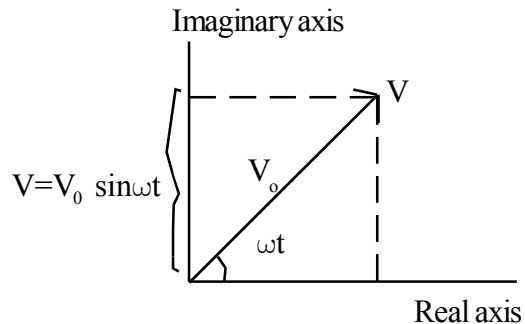
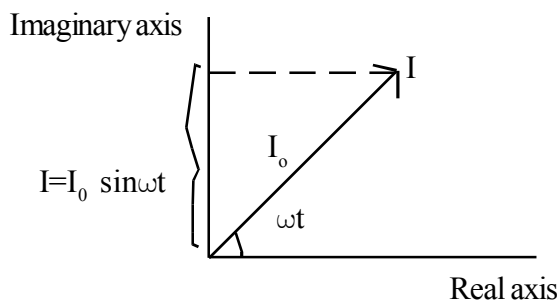

Length of the Phasor is amplitude

Projection of Phasor along the imaginary axis - Instantaneous value of voltage or current

What is RMS value or virtual value of AC (Since Average value of ac for a cycle is Zero)

$$V_{\text{rms}} = \sqrt{V_{\text{ms}}^2}$$

$$V = V_0 \sin \omega t$$

$$V^2 = V_0^2 \sin^2 \omega t$$

$$V_{\text{ms}}^2 = \frac{V_0^2}{2} \text{ (since average value of } \sin^2 \omega t \text{ for a complete cycle of ac is } \frac{1}{2}\text{)}$$

$$V_{\text{rms}} = \frac{V_0}{\sqrt{2}}, \quad I_{\text{rms}} = \frac{I_0}{\sqrt{2}}$$

- **Importance of RMS value**

- 1) To express ac power in the same form as dc power
- 2) It is used to construct hot wire instrument used for the measurement of ac

Note :

dc - Power $P = VI$

ac power $P_{\text{av}} = V_{\text{rms}} \times I_{\text{rms}}$

- **Ordinary MCG cannot used for measuring AC**

It indicates average value, The average value of ac is 0. Hence it shows no deflection

- Hot wire instrument is used for measuring ac. Principle of hotwire instrument is Heating effect

- 1) It is common to both ac and dc
- 2) It is independent of direction of current

- Graduation in the Galvanometer used for the measurement of ac is not equidistant.

It works on the basis of Heating effect.

Since $H = I^2 R$. Deflection in the galvanometer is directly \propto to I^2 But in MCG Deflection is $\propto I$

Disadvantages of ac -

1. Cannot used for electroplating - can't fix cathode and anode (Polarity of ac changes)
2. ac is more dangerous

$V_{\text{rms}} = 230\text{V}$ (line voltage)

$$V_0 = \sqrt{2} V_{\text{rms}}$$

$$\sqrt{2} \times 230 = 325\text{V}$$

3. It can't store for longer time.

Note - Thick Cu wire is used for flowing dc - It has low resistance - It is used as connecting wire in the lab.

- **Number of thin wires are used for flowing ac - why**

ac shows skin effect - ac is flowing on outer layer of a wire.

- **Electric main in a house is marked as 230V, 50Hz, write down the equation for instantaneous ac voltage.**

Instantaneous ac voltage $V = V_0 \sin \omega t$

$$V_0 = \sqrt{2}V_{\text{rms}} = \sqrt{2} \times 230 = 325 \text{ volt}$$

$$\omega = 2\pi\nu = 2\pi \times 50 = 100\pi$$

$$\therefore V = 325 \sin 100\pi t$$

AC circuit Containing resistor

Applied voltage, $V = \sin \omega t$ (1)

By Ω 's law, $I = \frac{V}{R} = \frac{V_0 \sin \omega t}{R}$

$I = I_0 \sin \omega t$ (2) where $I_0 = \frac{V_0}{R}$

From equation (1) and (2)

V and I are in the same phase

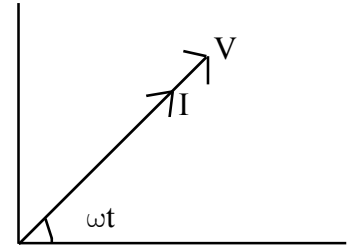
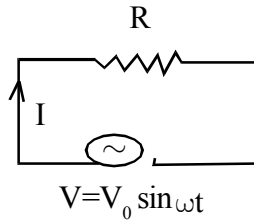

Power dissipation

$$P_{\text{av}} = \langle VI \rangle$$

$$= V_0 \sin \omega t I_0 \sin \omega t$$

$$2 \sin^2 \omega t = 1 - \cos 2\omega t$$

$$= V_0 I_0 \left(\frac{1 - \cos 2\omega t}{2} \right)$$

But $\frac{V_0 I_0}{2} \langle \cos 2\omega t \rangle = 0$ for 1 cycle of ac, $P_{\text{av}} = \frac{V_0 I_0}{2}$

$$P_{\text{av}} = V_{\text{rms}} \cdot I_{\text{rms}}$$

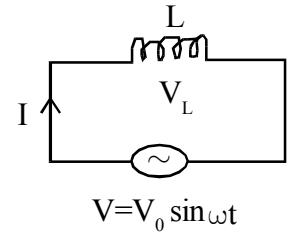

AC circuit containing inductor (L)

$$V = V_0 \sin \omega t$$

$$V_L = \frac{LdI}{dt} \quad (\text{since } V_L = V)$$

$$-LdI = V_0 \sin \omega t dt$$

$$LI = \frac{V_0 \cos \omega t}{\omega}$$

$$I = \frac{V_0}{\omega L} \sin \left(\omega t - \frac{\pi}{2} \right)$$

$$I = I_0 \sin \left(\omega t - \frac{\pi}{2} \right)$$

I lags V or V_L by $\frac{\pi}{2}$

Where $I_0 = \frac{V_0}{\omega L}$

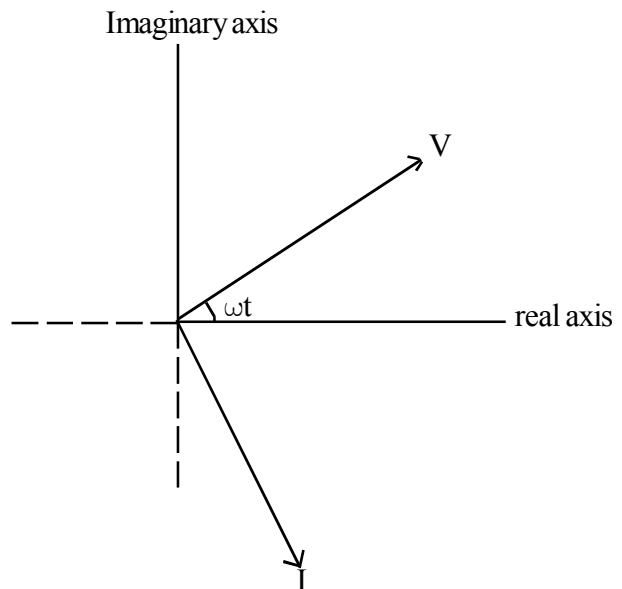

Hence ωL is the opposition offered by the inductor to ac called inductive reactance.

Inductive Reactance

$$X_L = \omega L$$

Note : for dc $\nu = 0$, $X_L = 0$

$$= 2\pi v L$$

$$\boxed{X_L \propto v}$$

Power Dissipation $P_{av} = \langle VI \rangle$

$$P_{av} = V_0 \sin \omega t - I_0 \cos \left(\omega t - \frac{\pi}{2} \right)$$

$$P_{av} = \frac{V_0 I_0}{2} 2 \sin \omega t \cos \omega t$$

$$P_{av} = \frac{V_0 I_0}{2} \sin 2\omega t$$

Average value $\langle \sin 2\omega t \rangle = 0$ for a cycle of ac

$P_{av} = 0$ (For ideal inductor)

AC circuit containing Capacitor C

$$V = V_0 \sin \omega t$$

$$I = C \frac{dV_c}{dt} \text{ But } V_c = V, I = C \frac{dv}{dt}$$

$$I = C \frac{d}{dt} V_0 \sin \omega t$$

$$I = C \omega V_0 \cos \omega t$$

$$\frac{V_0}{1/\omega C} \sin \left(\omega t + \frac{\pi}{2} \right)$$

$$I = I_0 \sin \left(\omega t + \frac{\pi}{2} \right)$$

I leads V or V_c by $\frac{\pi}{2}$

Where $I_0 = \frac{V_0}{1/\omega C}$ Amplitude of current

Here $\frac{1}{\omega C}$ is the opposition offered by capacitor to ac - capacitive reactance

$$X_c = \frac{1}{\omega C}$$

$$= \frac{1}{2\pi v C}$$

$$\boxed{X_c \propto \frac{1}{v}}$$

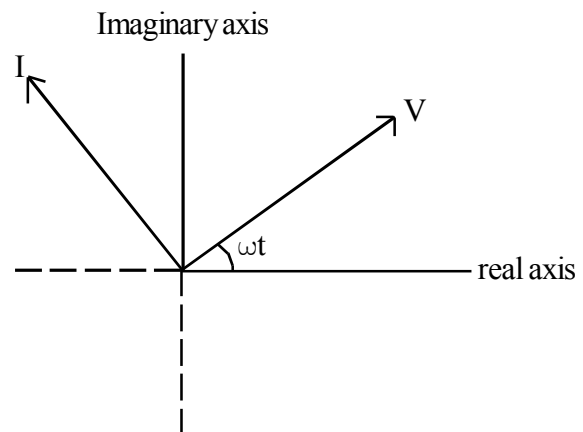
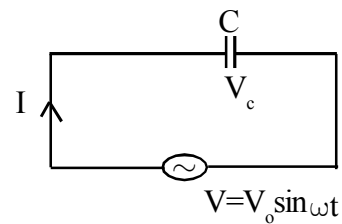

Note : for dc $v = 0$

$$X_c = \frac{1}{0} \Rightarrow \text{infinity}$$

Capacitor blocks dc

Power desipation $P_{av} = \langle VI \rangle$

$$P_{av} = V_o \sin \omega t \ I_o \sin (\omega t + \pi/2)$$

$$= \frac{V_o I_o}{2} \sin 2\omega t$$

Average value of sine $2 \omega t = 0$ for a complete cycle

$$\therefore P_{av} = 0 \text{ (Ideal)}$$

- In a purely resistive circuit power dissipation never be zero - Because V and I are always either +ve or -ve. Hence the product always +ve.
- In a purely inductive or capacitive circuit $P_{av} = 0$ what it shows - In the a circuit Inductor or capacitor offers opposition to ac with out loss of energy ie, current in the circuit does not perform any work. The current is called Idle or watt less current.

Explain AC circuit conatining LR

Amplitude of $V_R = I_o R$, which is in phase with current

$V_L = I_o X_L$ Which leads I by $\pi/2$

If V is the resultant of V_L and V_R , by vector algebra.

$$V = \sqrt{V_R^2 + V_L^2 + 2V_R V_L \cos \pi/2} \quad (\cos \pi/2 = 0)$$

$$V = \sqrt{(I_o R)^2 + (I_o X_L)^2}$$

$$\frac{V}{I_o} = \sqrt{R^2 + X_L^2} = Z, \text{ Impedence of LR circuit - Resistance offered by combination of L and R}$$

δ is the phase angle between V and I

$$\tan \delta = \frac{V_L}{V_R} \quad \tan \delta = \frac{I_o X_L}{I_o R}$$

$$\therefore \delta = \tan^{-1} \left(\frac{X_L}{R} \right)$$

Hence $V = V_o \sin \omega t$ 1

$I = I_o \sin (\omega t - \delta)$ 2

$V_R = R_o \sin (\omega t - \delta)$ 3

$V_L = X_L I_o \sin (\omega t - \delta + \pi/2)$ 4

$$\therefore |V|^2 = |V_R|^2 + |V_L|^2$$

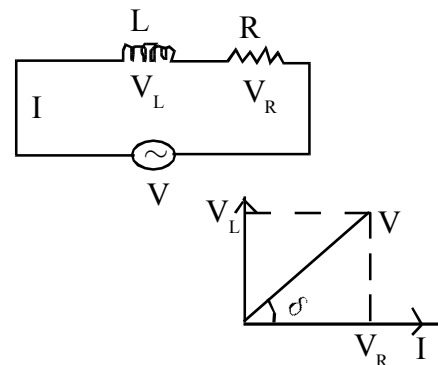

Phaser diagram

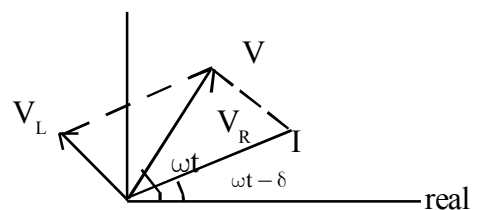

AC circuit cantaining C and R

Amplitude of

$V_R = I_o R$, Which is phase with I

$V_C = I_o X_C$ Which lags I by $\pi/2$

If V is the resultant voltage by vector algebra.

$$V = \sqrt{V_R^2 + V_C^2 + 2V_R V_C \cos \frac{\pi}{2}}$$

$$\frac{V}{I_0} = \sqrt{R^2 + X_C^2} = Z, \text{ Impedence of R C circuit}$$

δ - phase angle between V and I

$$\tan \delta = \frac{V_C}{V_R}$$

$$= \frac{I_0 X_C}{I_0 R} \therefore \delta = \tan^{-1} \left(\frac{X_C}{R} \right)$$

$$\text{Hence } V = V_0 \sin \omega t \dots\dots\dots 1$$

$$I = I_0 \sin (\omega t + \delta) \dots\dots\dots 2$$

$$V_R = R I_0 \sin (\omega t + \delta) \dots\dots\dots 3$$

$$V_C = X_C I_0 \sin (\omega t + \delta - \frac{\pi}{2}) \dots\dots\dots 4$$

$$|V|^2 = |V_R|^2 + |V_C|^2$$

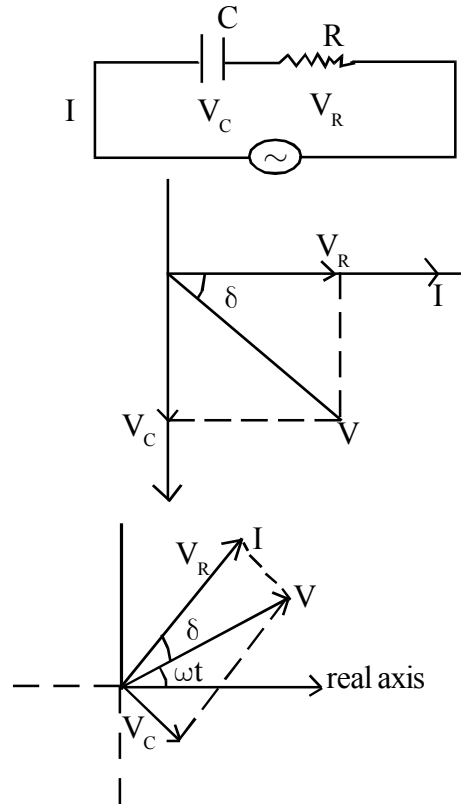

AC circuit Containing L and C

Amplitude of $V_L = I_0 X_L$ leads I by $\frac{\pi}{2}$

$V_C = I_0 X_C$ lags I by $\frac{\pi}{2}$

\therefore Phase angle between V_L and V_C is π

If V is the resultant voltage, by vector algebra.

$$V = \sqrt{V_L^2 + V_C^2 + 2V_L V_C \cos \pi}$$

$$V = V_L - V_C$$

$$V = I_0 X_L - I_0 X_C$$

$$\frac{V}{I_0} = X_L - X_C = Z, \text{ Impedence of LC circuit}$$

$$\text{Amplitude of current } I_0 = \frac{V}{Z}$$

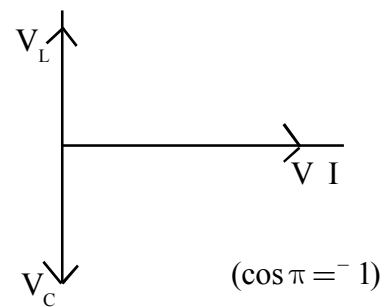
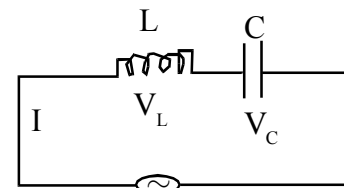

$X_L > X_C$ (At high frequency) Circuit is inductive $\therefore X_L \propto \omega$

$X_C > X_L$ (At low frequency circuit is capacitive $\therefore X_C \propto \frac{1}{\omega}$)

If $X_L = X_C, Z=0, I_0 \Rightarrow \infty$ (max). The circuit exhibits electrical resonance.

- Difference b/w resistance reactance and Impedence
Resistance - Opposition offered by a resistor - same for both dc and ac
Reactance - Opposition offered by inductor and capacitor to ac.

Impedences

Combined opposition offered by L, C & R to ac

- In heating coil heat produced is greater in dc than in ac

Impedence of heating coil is greater for ac

Since In dc $P = \frac{V^2}{R}$ In ac $P = \frac{V^2}{Z}$ Where $Z = \sqrt{R^2 + (WL)^2}$

- A coil of inductance $\frac{4}{\pi} H$ is joined in series with a resistance of 30Ω calculate the current in the circuit when it connected to an ac main of 200v and frequency 50Hz

$$I_{rms} = \frac{V_{rms}}{Z} \quad \text{Where } Z = \sqrt{R^2 + (\omega L)^2} = \sqrt{R^2 + (2\pi \nu L)^2} = \sqrt{30^2 + \left(2 \times 3.14 \times 50 \times \frac{4}{\pi}\right)^2}$$

$$= 401.1\Omega$$

$$\therefore I_{rms} = \frac{200}{401.1}$$

$$= 0.499A$$

- A lamp L is connected in series with the capacitor C. Predict your observations for dc and ac

For pure dc, bulb will not glow - capacitor blocks dc

For ac bulb glows - when c is low, X_C , $\frac{1}{WC}$ large .

Brightness reduces

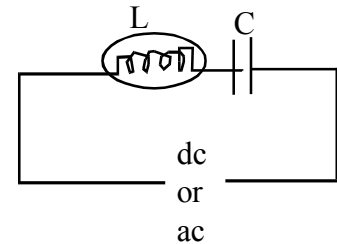

Explain ac circuit containing L, C and R - Series L C R circuit

Amplitude of $V_R = I_0 R$ which is in phase with I

$V_L = I_0 X_L$ which leads I by $\frac{\pi}{2}$

$V_C = I_0 X_C$ which lags I by $\frac{\pi}{2}$

Resultant of V_L and V_C is $V_L - V_C$ if $V_L > V_C$

If V is the resultant of V_C , V_L and V_R

$$V = \sqrt{V_R^2 + (V_L - V_C)^2 + 2V_R(V_L - V_C)\cos\frac{\pi}{2}}$$

$$V = \sqrt{V_R^2 + (V_L - V_C)^2}$$

$$V = \sqrt{(I_0 R)^2 + I_0^2 (x_L - X_C)^2}$$

$$\frac{V}{I_0} = \sqrt{R^2 + (X_L - X_C)^2} = Z, \text{ impedance of LCR circuit}$$

δ in the phase angle b/w V and I

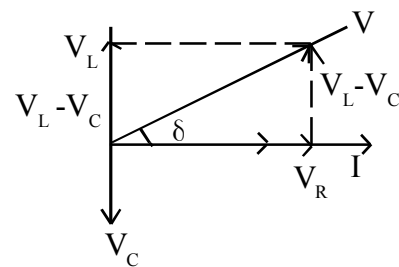
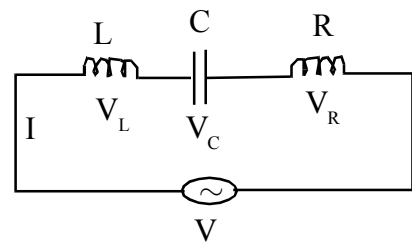

$$\tan \delta = \frac{V_L - V_C}{V_R} = \frac{I_0 X_L - I_0 X_C}{I_0 R} = \frac{X_L - X_C}{R}$$

$$\therefore \delta = \tan^{-1} \left(\frac{X_L - X_C}{R} \right) \therefore I = I_0 \sin(\omega t - \delta), \text{ where } I_0 = \frac{V_0}{Z}$$

Hence $V = V_0 \sin(\omega t)$ applied voltage

$I = I_0 \sin(\omega t - \delta)$ current in the circuit.

I lags V by δ .

$$V_L = I X_L = X_L \sin(\omega t - \delta + \pi/2) \text{ leads } I \text{ by } \pi/2$$

$$V_C = I X_C = X_C \sin(\omega t - \delta - \pi/2) \text{ lags } I \text{ by } \pi/2$$

$$V_R = I R = R I_0 \sin(\omega t - \delta) \text{ Phase with in current.}$$

Phaser diagram ($X_L > X_C$) of LCR Circuit

$$\therefore \therefore |V|^2 = |V_R|^2 + |V_L|^2 + |V_C|^2$$

Electrical resonance in LCR

At resonance Amplitude of current

$$I_0 \Rightarrow \max$$

$$\text{But } I_0 = \frac{V_0}{\sqrt{R^2 + (X_L - X_C)^2}}$$

It is maximum only when $X_L = X_C$ or $V_L = V_C$ or $\delta = 0$

\therefore Impedence of resonant LCR circuit $Z = R$

* Resonant current in the circuit $I_0 = \frac{V_0}{R}$

* The frequency at which LCR circuit exhibits resonance is called resonant frequency

$$\text{Since } X_L = X_C \quad \omega L = \frac{1}{\omega C} \quad \therefore \omega_r = \frac{1}{\sqrt{LC}} \quad \text{Hence frequency } \nu_r = \frac{1}{2\pi\sqrt{LC}} \quad \text{Note: } \omega = 2\pi\nu$$

Resonance depends on L and C

What are the uses of LCR circuit

1. Used in the tuning mechanism of Radio, TV
2. Metal detector

What is Q factor in LCR circuit - Shows sharpnes of resonance. If I_0 is max sharpnes is greater

$$\text{At resonance } Q = \frac{X_L}{R} \text{ or } \frac{X_C}{R} \quad \text{i e, } Q = \frac{\omega_r L}{R} \text{ or } \frac{1}{\omega_r C R}$$

If

$X_L > X_C, \delta$ is +ve I lags V

$X_L < X_C, \delta$ is -ve I leads V

$X_L = X_C, \delta$ is zero I and V

in the same phase

Assignment :
Draw Phaser diagram of
LCR circuit with $X_C > X_L$

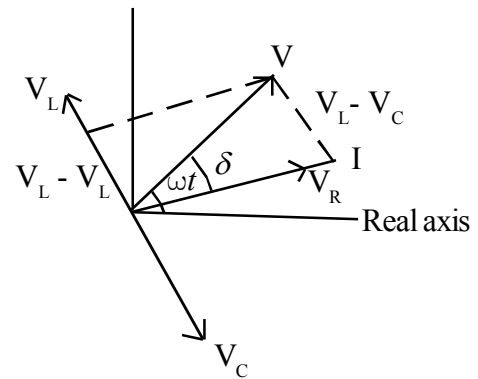

Selectivity of LCR circuit - Depends on Q - factor

I_0 is max when R is low since at resonance $I_0 = \frac{V_0}{R}$

* In parallel LCR circuit Current vanishes for a certain frequency only such a circuit is filter circuit.

Power dissipation in LCR circuit

Average power (True power) consumed during one cycle of ac.

$$P_{av} = \frac{\int_0^T VI dt}{\int_0^T dt}$$

$$P_{av} = \frac{\int_0^T V_0 \sin \omega t I_0 \sin(\omega t - \delta) dt}{\int_0^T dt}$$

$$\frac{\int_0^T V_0 \sin \omega t I_0 (\sin \omega t \cos \delta - \cos \omega t \sin \delta) dt}{\int_0^T dt}$$

$$P_{av} = \frac{\int_0^T V_0 I_0 \sin^2 \omega t - \cos \delta dt}{\int_0^T dt} - \frac{\int_0^T V_0 I_0 \sin \omega t - \cos \omega t \sin \delta dt}{\int_0^T dt}$$

$$= V_0 I_0 \cos \delta \frac{\int_0^T \sin^2 \omega t dt}{\int_0^T dt} - \frac{V_0 I_0}{2} \sin \delta \frac{\int_0^T \sin 2\omega t - dt}{\int_0^T dt}$$

$$\text{For a complete cycle } \left\langle \frac{\int_0^T \sin^2 \omega t dt}{\int_0^T dt} \right\rangle = \frac{1}{2}, \left\langle \frac{\int_0^T \sin 2\omega t dt}{\int_0^T dt} \right\rangle = 0$$

$$P_{av} = \frac{V_0 I_0}{2} \cos \delta$$

$$P_{av} = V_{rms} I_{rms} \cos \delta$$

True Power = Apparent power x Power factor

- Explain power factor - It signifies power loss

$$\cos \delta = \frac{R}{Z}$$

At resonance $Z = R$, $\cos \delta = 1$ $P_{av} = I_{rms} V_{rms}$, maximum

- If the circuit is pure inductive or capacitive $\delta = \pi/2$, $\cos \pi/2 = 0$, $p_{av} = 0$
- What is power factor in Resistive circuit.

In ac resistive circuit $\delta = 0$, V and I are in same phase

$$\cos \delta = 1, P_{av} = I_{rms} V_{rms}$$

- What is the min and max value of power factor - 0 and 1
- Total impedance of circuit decreases when capacitor is added in series with the given impedance - Explain -
The capacitance reduces the net reactance and hence the impedance decreases
- What is the disadvantage in supplying a given power to a circuit having low power factor. To supply a given power in a circuit (Transmission line) having low power factor a large current is required. This produces large heat loss.

Evaluation

- 1) What is meant by ac, How can you represent ac mathematically
- 2) What is the mean value of ac for one complete cycle
- 3) An ac of 220 V is more dangerous than a DC of 220V -
- 4) In a DC circuit what is the reactance of
a) Inductor b) Capacitor
- 5) Why voltages across L and C in series are π out of phase
- 6) What is the nature of impedance of an LCR circuit if the applied frequency (ν)(i),
 $\nu = \nu_r$ (2), $\nu > \nu_r$ (3) $\nu < \nu_r$
- 7) Draw graphics showing variation of reactance 1) A capacitor 2) an inductor with frequency of applied voltage

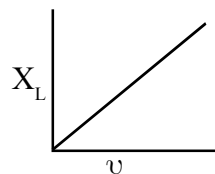
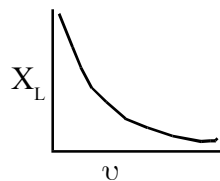

- 8) Properties of resonant LCR circuit
- 9) If the frequency of ac is doubled how do R, X_L and X_C get affected
- 10) What do you mean by amplitude of AC, How it related to RMS value

* There is no electrical resonance in LR or RC circuit - Resonance takes place only if L and C. Present, Because V_L cancelled by V_C .

* Variation of X_L with ω .
 $X_L = \omega L$

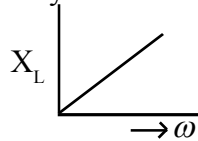

* Resonant LCR circuit is acceptor circuit - Admits maxi current at resonance.

* Variation of X_C with ω
 $X_C = \frac{1}{\omega c}$

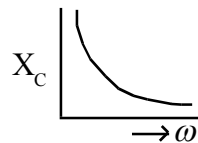

* Importance of acceptor circuit in tuner of Radio, TV receiver by tuning (varying) the capacitance of variable capacitor in the LCR circuit the natural frequency of LCR circuit is made equal to the frequency of the signal (EM wave) to be detected.

* Variation of R with ω
 R independent of ω

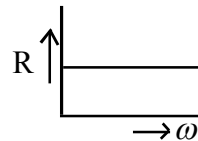

* Variation of I with ω
 $I = I_0 \sin \omega t$
 (Sine curve)

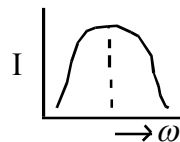

* Variation of Z with ω
 $Z = \sqrt{R^2 + \left(\omega L - \frac{1}{\omega c}\right)^2}$

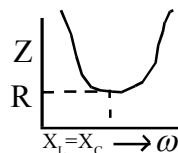

* Can a capacitor of suitable capacitance replace a choke coil in an AC circuit.
 Yes. AC voltage lags behind the current in capacitor circuit and $P_{av} = 0$.

Transformers

- Used to change the alternating voltage and current without changing its frequency
- Working Principle Mutual induction. (Electro magnetic induction)
- Transformers works in only ac not in dc. Because its working principle is Electromagnetic Induction.

Transformer law of voltages

N_p, N_s , Number of turns in the primary and secondary coils

ϕ_B Magnetic flux in the ironcore linked with Primary and Secondary coils.

Total flux linked with the Primary coil $\phi_p = N_p \phi_B$

\therefore Emf induced in the primary coil $\varepsilon_p = -N_p \frac{d\phi_B}{dt}$

similarly, $\varepsilon_s = -N_s \frac{d\phi_B}{dt}$

$$\frac{\varepsilon_s}{\varepsilon_p} = \frac{N_s}{N_p}$$

$\varepsilon_p = V_{p-}$, applied voltage, $\varepsilon_s = V_s$, Terminal voltage $\frac{V_s}{V_p} = \frac{N_s}{N_p} = K$ is a constant called turns ratio or Transformer ratio.

Types of transformers

Step up transformer

If $N_s > N_p$, $V_s > V_p$ primary voltage is increased

so, $I_s < I_p$ then $R_s > R_p$, secondary coil is thinner than primary coil.

Step down transformer

If $N_s < N_p$, $V_s < V_p$ primary voltage is reduced.

SO, $I_s > I_p$ then $R_s < R_p$ secondary coil is thicker than primary coil.

- For a transformer if there is no power loss (Ideal case)

ac input power = ac output power

$$V_p I_p = V_s I_s$$

- Efficiency of transformer = $\frac{\text{output power}}{\text{input power}}$ $\eta = \frac{V_s I_s}{V_p I_p}$
- In a transformer there is no violation of law of conservation of energy.
Input ac energy = output ac energy (Ideal case)

* Application of Transformer - Electrical Power Transmission.

- * Electric power is transmitted in ac not dc - In Electrical power transmission transformer is used in various stages. It works only in ac.
- * Energy losses in a transformer.
 - (i) Copper loss or Joule loss - Due to resistance of primary and secondary coils.
 - (ii) Eddy current loss or Iron loss.
 - (iii) Hysteresis loss
 - (iv) Flux leakage - Because total flux linked with the primary coil is not
 - (v) Humming Noise- linked with secondary coil
- * How can reduce the flux leakage in a transformer.
By winding secondary coil over primary coil and insulated each other.
- * Device which is used to step down dc - Resistor
- * Device which is used to step up dc - Induction coil

* * *

Chapter 7

ELECTROMAGNETIC WAVES

- ST Ampere's circuital law $\oint Bdl = \mu_0 I$ is inconsistent

$$\oint_{C_1} Bdl = \mu_0 I \dots \textcircled{1}$$

$$\oint_{C_2} Bdl = 0 \dots \textcircled{2}$$

If amperian loops C_1 and C_2 are very close and it is logical to expect that

$$\oint_{C_1} Bdl = \oint_{C_2} Bdl \dots \textcircled{3}$$

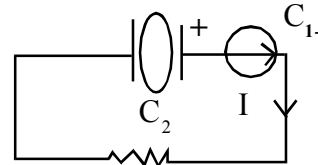

(Note: Outside the capacitor $I_c \neq 0$,
Conduction Current
inside the capacitor $I_c = I_d \neq 0$,
displacement Current)

This shows that Ampere's circuit law is inconsistent because equation (3) is a contradiction with eqs: (1) and (2)

- Maxwell's modified form of Ampere's circuital law.

$$\oint Bdl = \mu_0 \left(I_c + \epsilon_0 \frac{d\phi_E}{dt} \right)$$

I_c - Conduction current - Rate of flow of electric charge

$$\frac{\epsilon_0 d\phi_E}{dt} = I_d \text{ - Displacement current - Current due to changing Electric field.}$$

Significance of displacement current

The concept of displacement current satisfies the current is continuous

Electric flux $\phi_E = EA$

$$\phi_E = \frac{Q}{\epsilon_0 A} A \left(\text{Using } E = \frac{\sigma}{\epsilon_0}, \sigma = \frac{Q}{A} \right)$$

$$\frac{d\phi_E}{dt} = \frac{1}{\epsilon_0} \frac{dQ}{dt}$$

$$\therefore I_d = \epsilon_0 \frac{d\phi_E}{dt} = \frac{dQ}{dt} \text{ Rate flow of electric charge}$$

- Consequences of displacement current
 - 1) Farady's law of electromagnetic induction $e = \frac{d\phi_B}{dt}$
 - 2) Modified form of ampere's circuital law/
- Total current is the sum of conduction current and displacement current is $I = I_c + I_d$

Maxwell's four equations

1. $\oint E \cdot ds = \frac{q}{\epsilon_0}$ - Gauss' law in electrostatics
2. $\oint B \cdot ds = 0$ Gauss' law in Magnitism
3. $\oint E \cdot dl = \frac{d\phi_B}{dt}$ (Fareday's law)
4. $\oint B \cdot dl = \mu_0 \left(I_C + \epsilon \frac{d\phi_E}{dt} \right)$ Ampere - Maxwell Law

- Induced emf $e = \frac{d\phi_B}{dt} = \int E d\ell$, work done in bringing unit charge along a closed path.
- Source of electromagnetic wave - oscillating electric charge
- An electric charge osulating with a frequency ν Produces electromagnetic wave of same frequency

Note : A charge at rest Produces electric field
 A Charge in motion Produces EF and MF

- Graphical representation of EF(E_0) and MF(B_0) associated with EMW

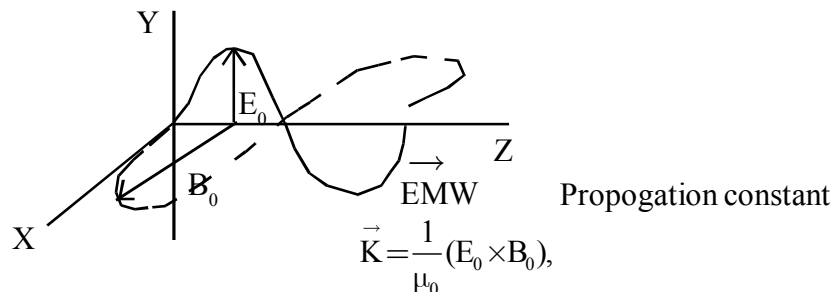

- Mathematical representation of EF and MF associated with EMW

$$B_x = B_0 \sin(Kz - \omega t)$$

$$E_y = E_0 \sin(Kz - \omega t)$$

$$B_x = B_0 \sin 2\pi v \left(\frac{z}{c} - t \right)$$

$$E_y = E_0 \sin 2\pi v \left(\frac{z}{c} - t \right) \text{ Where } c \text{ velocity of EMW}$$

E_0, B_0 - amplitude of \vec{E} and \vec{B}

$K = \frac{2\pi}{\lambda}$ - Propagation constant or wave number. Gives the direction of propagation of EM wave.

Expressions for velocity of EMV

$$C = v \lambda, \quad C = \frac{1}{\sqrt{\mu_0 \epsilon_0}}, \quad C = \frac{\omega}{K}, \quad C = \frac{E_0}{B_0}$$

- What is the phase angle b/w E and B in EM W zero. Because EF and MF reach their max value and min value at the same time.
- What is the orientation of EMW, It is mutually perpendicular EF and MF

Important observations of electromagnetic waves

I. James clerk Maxwell's predictions -

- 1) EM waves propagate in the form of EF and MF, such that both the fields are perpendicular to each other and perpendicular to the direction of propagation of wave.
- 2) Velocity of em wave in free space is $C = \frac{1}{\sqrt{\mu_0 \epsilon_0}}$
 μ_0 - permeability of free space ϵ_0 - permittivity of free space
- 3) There is a definite ratio between E and B, is $C = \frac{E}{B}$
- 4) \vec{E} and \vec{B} at each point of oscillate in the same phase (Phase angle between E and B is zero)
- 5) Accelerated electric charge (oscillating electric dipole) is the source of em wave.
- 6) An electric charge oscillate with a frequency produces em waves of the same frequency.

- II In 1888 Hertz demonstrated the production of em wave using accelerating electric charge with help of "Spark gap oscillator"

- III In 1895 J C Bose succeeded in producing electromagnetic wave of much smaller wave length (5mm - 25mm) called microwaves
- IV In 1896 Macroni discovered that electromagnetic wave can radiate up to several kilometers.

Properties of EM waves

- 1) Combination of EF and MF
 - 2) Propagates with the speed of 3×10^8 m/s in free space
 - 3) Shows Transverse wave nature
 - 4) No Material medium for its propagation
 - 5) No deflection in EF and MF
 - 6) Wavelength is less hence frequency will be greater
 - 7) It carries momentum as well as energy
- Shows that EM waves carry momentum as well as energy
 $U = mc^2$ where c velocity of EM wave
 $U = mc \cdot c$
 $U = pc$
Momentum $P = \frac{U}{C}$
 - When sun rays fall on our hand you do not feel pressure. Due to small momentum. Average force
 $F = \frac{\Delta P}{\Delta t}$ But $\Delta P = \frac{U}{C}$ if C is large, momentum ΔP is small.
Hence F is small
Pressure exerted $\Delta P = \frac{F}{A}$ if F is small, ΔP is small
 - Light with an energy flux (Intensity) 18 w/cm^2 fall on a perfectly non reflecting surface at normal incidence. If the surface of area in 20 cm^2 , Find the average force exerted on the surface in 3 minutes.

$$\text{Average force } F = \frac{\Delta P}{At} \text{ But } \Delta P = \frac{U}{C} \text{ where } U = \phi At$$

$$= 18 \times 10^4 \times 20 \times 10^{-4} \times 3 \times 60 = 6.48 \times 10^4 \text{ J}$$

$$\Delta P = \frac{6.48 \times 10^4}{3 \times 10^8} = 2.16 \times 10^{-4} \text{ kgm/s}$$

$$F = \frac{2.16 \times 10^{-4}}{3 \times 60} = 1.2 \times 10^{-5} \text{ N}$$

Note : Energy flux is the energy incident per unit area per unit time, $\phi = \frac{U}{At}$. It unit is w/m²

- What is radiation Pressure - Pressure exerted by em wave-)
- Which factor is used for distinguishing em wave - justify.

Frequency It remains un changed

- Total energy density of em wave

$$\text{Energy density of EF} = \frac{1}{2} \epsilon_0 E^2$$

$$\text{Energy density of MF} = \frac{1}{2\mu_0} B^2$$

$$\text{Total energy density of EM wave } U = \frac{1}{2} \epsilon_0 E^2 + \frac{1}{2\mu_0} B^2$$

- Electro magnetic spectrum

Arrangments of em waves according to their wave length or frequency

10^{-12}	10^{-10}	10^{-8}	10^{-7}	10^{-4}	10^{-3}	10^6
γ rays	x rays	uv	VL	IR	MW	RW

→ wave length (λ) in metre.

γ - Radiations

Definition : EM wave of wave length $\sim 10^{-12}$ m

Origin - Nuclear reactions

Uses - Study structure of nuclei, Medical Applications

Used to produce nuclear changes - γ - radiation are high energy radiations.

X-rays

Definition : EM waves of wavelength $\sim 10^{-10}$ m

Origin : When high speed electrons are stopped by a target(x-ray tube by Roentgen)

Uses : Study structure of atoms molecules and crystals, medical application.

UV rays

Definition : EM wave of wave length of $\sim 10^{-8}$ m

Source : Sun, Outer Electrons in atoms

Uses : Medical Application, Increase the resolving Power of micro scope, develops vitamin D in human body. Water purification

- Importance of ozone layer in the earth's atmosphere - uv radiation emitted form the sun are harmful to all living organisms. Ozone layer protect us from the harmful effect of these radiations.

- Why uv radiations used In LASIK (eyesurgery) - due to short wavelength it can be focussed in to a narrow beam.
- Use of goggles (face mask used by welders) and glass window, uv radiations are absorbed.

IR waves

Definition : EM waves of wavelength $\sim 10^4\text{m}$

Source : Hot object, sun

(Vibrations of atoms, molecules)

Uses Distant photography - IR radiations are not absorbed by air or mist or fog.

Medical application, Secret Signalling (Remote control in TV)

- IR radiations are Heat radiations, - Materials absorbs these radiations and gets heated up.
- Glass is opaque to these radiations.
- What are the two invisible radiations present in sun light - How they are detected.

IR and UV : Presence of IR from their heating effect, UV can change photographic plate.

What is Green House effect

- The clouds, CO_2 , O_2 , N_2 and other gas molecules present in the lower atmosphere of the earth reflects IR radiations back and keep the earth's surface warm at night,
(Note : Earth's atmosphere - Gases envelope around the earth)
- We feel warm on cloudy day -
If the atmosphere contains more clouds then due to green house effect a large amount of IR radiations will be reflected back to the earth.
- If the earth did not have an atmosphere would its average temperature (15°C) be higher or lower. If there is no atmosphere it can't retain the IR radiations.
- What is Nuclear Winter : If a global nuclear war takes place the dust particles and nuclear waste may form clouds covering major part of the sky. This prevents solar energy from reaching the earth. Thus the earth became cooler.

Mircro waves

Definition : EM wave of wavelength $\sim 10^{-3}\text{m}$

Source : Electron oscillating in a cavity (device Magnetron Valve)

Uses : Radar, Telecommunication, Telecast

- Why microwaves are used for signal Transmission -Due to small wavelength. They can be sent in a particular direction because they are not diffracted by obstacles.
- It is necessary to use satellites for long distance TV transmission. Microwaves are used for long distance TV transmission. Microwaves are not reflected by the Ionosphere (Highest atmosphere of the earth) Hence satellites are used to reflect those waves.

Explain the principle of Microwave oven

The frequency of the microwave is selected in match with the resonant frequency of water molecules. So that energy from the waves is transferred to the KE of the molecules. This raises the temperature of any food containing water

Radio Waves

Definition : EM waves of wavelength $\sim 10^6\text{m}$

Source : Accelerated motion of charge in conducting wire (Oscillator or Tank Circuit)

Uses : Radio, TV, Cellular Phone

- Optical and Radio Telescope are built on the ground but x ray astronomy is possible only from satellite - The earth's atmosphere is transparent to visible light and radio waves, But x-rays are absorbed. Therefore x-ray astronomy is not possible on the ground. Since satellites are at high altitude above the atmosphere x-ray astronomy is possible from satellite.

What are the frequency range of Radio waves

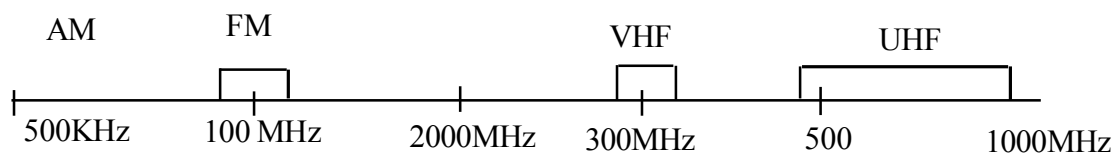

AM - Amplitude Modulation, 530KHz-1710KHz. For short distance Broad casting

SW - 1710KHz - 54Mhz long distance Broad casting

FM - Frequency modulated 88Mhz 108Mhz (FM radio)

UHF - Cellular Phones 500Mhz - 1000Mhz

- Radio waves diffract around a building while light waves are not. For a wave to suffer diffraction the wave length should be of the order of the size of the obstacle. Wave length of Radio wave is of the order of size of the building but that of light wave is small compared with the size of the obstacle.

Chapter 8

OPTICS AND OPTICAL INSTRUMENTS

Optics deals origin, motion and detection of light. It is classified in to three.

- 1) **Ray optics (Geometrical optics)** : Deals light as ray- stream of corpuscles (Tiny, weightless elastic particles emitted by luminous body) moving along a straight line
- 2) **Wave Optics (Physical Optics)** : Deals light as wave
- 3) **Photon optics** : Deals light as waves with discrete Photon

What is the nature light?

Maxwell and Hertz realised that light is em wave

Important Phenomenon of light

Reflection : The process of rebounding beam of light form a Polished surface

(Note: Beam of light - Combination of light rays)

Write laws of reflection

- 1) IR and RR and Normal (N) to the point of incidence all lie in the same plane.
- 2) Angle of incidence (i) is equal to Angle of reflection (r)

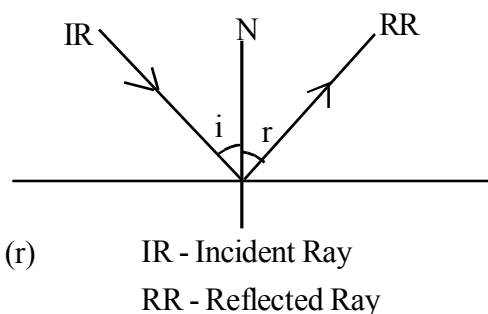

Spherical Mirrors :

- (i) **Concave** : Reflecting side bend inward
- (ii) **Convex** : Reflecting side band outward.

Show that Principal focus is the mid point of radius of curvature

$$\text{From } \triangle BDC, \tan \theta = \frac{BD}{DC}$$

$$\text{From } \triangle BDF, \tan 2\theta = \frac{BD}{DF}$$

For small aperture of the mirror D is very close to V

$$\tan \theta = \frac{BD}{VC}$$

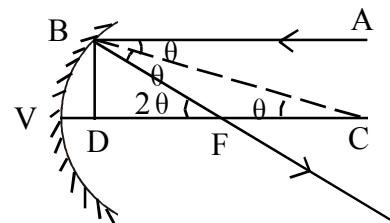

Note: Aperture \overline{AB} , is small compared with aperture $\overline{A'B'}$

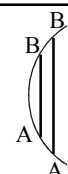

$$\tan 2\theta = \frac{BD}{VF}$$

If θ is small,

$$\frac{2\theta}{\theta} = \frac{VC}{VF} = \frac{R}{f}$$

(VF = f, focal length
VC = R, Radius of curvature)

$$\therefore f = \frac{R}{2}$$

- Difference between real and virtual images.
Real image - Formed on a screen, inverted
Virtual image - Can not formed on a screen, erect.
- Virtual images can not formed on a screen but can be seen - virtual image formed acts as virtual object to the eye lens which produces real image on the retina.
- Nature of image formed by a plane mirror - virtual, erect, same size, laterally inverted and $u=v$
- Focus of a plane mirror is at infinity- Justify
Reflected rays do not converge
- Why convex mirror is used as rear view mirror in automobiles-wider field of view.
- OBJECTS IN THE MIRROR ARE CLOSER THAN THEY APPEAR'
This is written on rear view mirror - Justify
It can not give exact distance of approaching vehicle
(For a convex mirror if object is placed at any where in front of the mirror the image is formed in between the mirror and Principle focus)

• Derrive Mirror Equation

OB - Object, IM Image

AB, BV - Incedent rays,

VO = -u object distance

VI = -v image distance

VF = -f focal length.

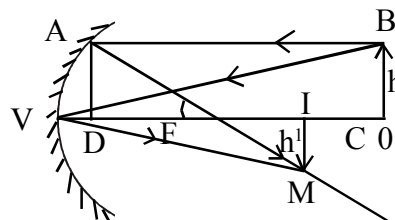

Sign Conventions

[**Note I** : All the distances are measured from V (vertex of mirror - mid point of mirror)]

- (i) distance against IR is -ve
 - (ii) distance along IR is +ve
- II** All heights are measured from the Principal axis
- (i) Height upward is +ve
 - (ii) Height down ward is -ve]

$$\triangle IMF \sim \triangle ADF, \frac{IM}{AD} = \frac{IF}{DF} \quad \begin{matrix} (AD = OB \\ DF = VF \text{ for small aperture}) \end{matrix}$$

$$\frac{IM}{OB} = \frac{IF}{VF} = \frac{-V + f}{-f} \quad \text{----- (1)}$$

$$\triangle IMV \sim \triangle OBV, \frac{IM}{OB} = \frac{OV}{IV} = \frac{-V}{-u} \quad \text{----- (2)}$$

From equation, (1) and (2), $\frac{-v + f}{-f} = \frac{-v}{-u}$

x and by $\frac{1}{v}$, $\frac{V}{f} - 1 = \frac{V}{u}$

$$\frac{1}{f} - \frac{1}{v} = \frac{1}{u} \quad \text{(Note : Lesser the diameter lesser the aperture)}$$

$$\frac{1}{f} - \frac{1}{v} = \frac{1}{u}$$

$$\underline{\underline{\frac{1}{f} = \frac{1}{u} + \frac{1}{v}}}$$

Note: Put $f = \frac{R}{2}$, $\frac{1}{u} + \frac{1}{v} = \frac{2}{R}$

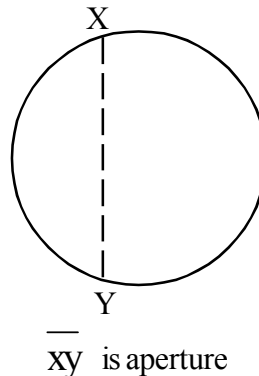

Linear Magnification

$$m = \frac{\text{Height of Image}}{\text{Height of Object}} = \frac{-h^1}{h} \quad \text{or} \quad m = \frac{\text{Image Distance}}{\text{Object Distace}} = \frac{-v}{-u}$$

$$m = \frac{h^1}{h} = \frac{-v}{u}$$

Relation between m, u and f

$$\frac{1}{u} + \frac{1}{v} = \frac{1}{f}$$

Multiplying by u

$$1 + \frac{u}{v} = \frac{u}{f}$$

$$\frac{-u}{v} = 1 - \frac{u}{f}$$

$$\frac{1}{m} = \frac{f - u}{f}$$

$$m = \frac{f}{f - u}$$

Relation between m, v and f

$$\frac{1}{u} + \frac{1}{v} = \frac{1}{f}$$

Multiplying by v

$$\frac{v}{u} + 1 = \frac{v}{f}$$

$$\frac{v}{u} = \frac{v}{f} - 1$$

$$-m = \frac{v - f}{f}$$

$$m = \frac{f - v}{f}$$

- What do you mean by conjugate focus of concave mirror?
The positions of the object and real image formed by a concave mirror are interchangeable. Pairs of such points on the principal axis are conjugate foci.
- What is Spherical aberration - Inability of a concave mirror to converge all parallel rays to a single point (Defect of concave mirror)
- Methods to reduce spherical aberration
Use small aperture concave mirror.
(Use Parabolic concave mirror)
- Will focal length of a mirror change if it is placed in water?
No Focal length of a mirror is independent of the medium.
- What is the minimum distance between the object - and its real image formed by a concave mirror - Explain.

0 (Since $u = -R$, Radius of curvature)

$$\frac{1}{f} = \frac{1}{u} + \frac{1}{v}$$

$$\text{if } u = -R, \quad \frac{1}{f} = \frac{1}{-R} + \frac{1}{v}$$

$$\frac{1}{v} = \frac{1}{f} + \frac{1}{R}$$

$$\frac{1}{v} = \frac{-2}{R} + \frac{1}{R} \text{ (Using } f = \frac{-R}{2} \text{)}$$

$$\frac{1}{v} = \frac{-1}{R}$$

$v = -R$ (For real image V is -ve)

- Show that the image formed by a convex mirror is virtual erect and diminished.

$$\frac{1}{u} + \frac{1}{v} = \frac{1}{f}, \text{ for convex mirror } u \text{ is -ve, } f \text{ is +ve.}$$

$$\frac{1}{v} = \frac{1}{f} + \frac{1}{u}$$

Hence v is the +ve - image is formed behind the mirror (virtual)

$$m = \frac{f}{f - u}$$

Put sign convention, $m = \frac{f}{f + u} < 1$, diminished. (u is -ve)

m is +ve erect image.

- ST for a plane mirror, $u=v$

$$\frac{1}{f} = \frac{1}{u} + \frac{1}{v}$$

By sign convention, u is -ve, v is +ve

For a plane mirror, $f = \infty$, $\frac{1}{f} = 0$

$$0 = \frac{1}{-u} + \frac{1}{v}, \therefore u=v.$$

- A ray of light incident normally on a plane mirror it retraces its path. For normal incidence on a plane mirror, angle of incidence = 0, Hence angle of reflection must be zero. It is possible only when the ray retraces its path.
- Can you Photograph virtual image. Yes Virtual image acts as virtual object to the lens of camera. Which produces real image on the Photographic plate

Assignments :

- Show that $f = \frac{R}{2}$ using convex mirror

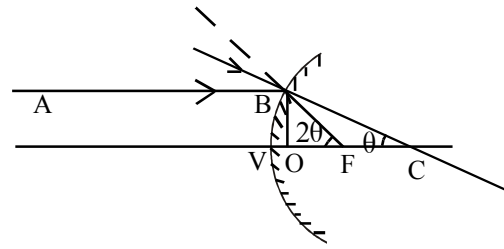

- Derrive mirror equation using convex mirror

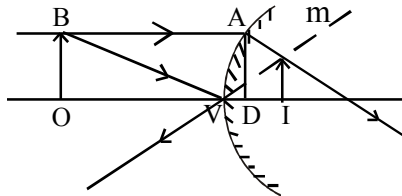

Spherical Abberation

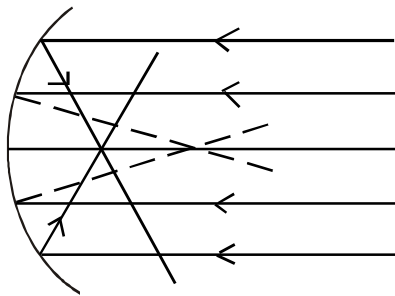

Note : Marginal ray - Ray far from Principal axis

Paraxial Ray - Ray close to Principal axis ray.

Innability of a concave mirror to converge all the parallel lays to a single point. This defect can be minimised by using stops which cut off marginal rays. Stops - Diaphrem with small opening.

Uses of Spherical Mirror

Concave Mirror

- 1) Shaving Mirror
- 2) Used in search light, Automobile head light
- 3) Concave shade
- 4) Reflecting Telescope

Convex Mirror

- 1) Rear view mirror in Automobiles
- 2) As the shades in street light. In order to spread light in large areas.

- **Assignments :** Image formed by spherical mirror. Draw the diagrams.

I Concave Mirror

- a) Object at infinity
- b) Object beyond C
- c) Object at C
- d) Object in between C and F
- e) Object at F
- f) Object in between F and V

II Convex Mirror

- (a) Object at Infinity
- (b) Object in between V and infinite distance

- If a and b are the distances of the object and the real image from the focus of a concave mirror of focal length f . Show that $f = \sqrt{ab}$

$$u = -(f+a)$$

$$v = -(f+b)$$

For concave mirror,

$$-\frac{1}{f} = \frac{1}{-(f+a)} + \frac{1}{-(f+b)}$$

$$-\frac{1}{f} = \frac{-f-b-f-a}{(f+a)(f+b)}$$

$$-f^2 - fb - af - ab = -f^2 - fb - f^2 - fa$$

$$f^2 = ab$$

$$f = \sqrt{ab}, \text{ Newtons formula}$$

Refraction

- What is refraction? - What is the reason?

Bending of light at the surface of separation of two media. It is because of difference in optical density between the media.

- Difference between optical density and mass density

Optical density - Opposition offered by a medium to the propagation of light

Mass density - Mass per unit volume, called density.

- Define angle of deviation (d) - Angle b/w the incident ray and refracted ray
- Snell's Law of Refraction -

Refractive index of medium 2 with respect to medium 1

$$n_{21} = \frac{\sin i}{\sin r} \quad i \text{ angle of incident, } r \text{ angle of refraction}$$

- $n_{21} = \frac{n_2}{n_1}$

- Refractive index of a medium with respect to air $n = \frac{c}{V}$

c - velocity of light in air

v - velocity of light in glass

$$\therefore V = \frac{c}{n}$$

$v \propto \frac{1}{n}$ greater the refractive index smaller is the velocity of light.

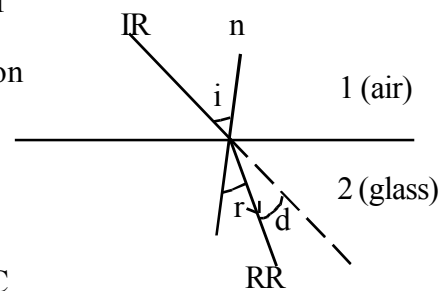

RR - Refracted Ray

Eg: for glass $n = 1.5$ and for water $n = 1.3$

$$\therefore V_{\text{glass}} < V_{\text{water}}$$

- Refractive indices of water and glass are $4/3$ and $3/2$ respectively. A light ray travelling in water is incident on water glass interface at 30° ,

What is, 1) n_{gw}

2) Angle of refraction at water - glass interface.

$$n_{\text{gw}} = \frac{n_{\text{ga}}}{n_{\text{wa}}} = \frac{3/2}{4/3} = \frac{9}{8}$$

$$\frac{\sin r_1}{\sin r_2} = n_{\text{gw}} = \frac{9}{8}$$

$$\sin r_2 = \frac{8}{9} \sin 30$$

$$\sin r_2 = \frac{8}{9} \times 0.5$$

$$r_2 = \sin^{-1}(0.44)$$

- Show that, $n_{21} = \frac{n_2}{n_1}$

$$n_{21} = \frac{v_1}{v_2}$$

$$n_{21} = \frac{v_1}{c} \cdot \frac{c}{v_2} = \frac{1}{n_1} \cdot n_2$$

$$n_{21} = \frac{n_2}{n_1}$$

- Refractive index decreases with temperature

- Show that $n_{\text{gw}} = \frac{n_{\text{ga}}}{n_{\text{wa}}}$

$$n_{\text{wa}} = \frac{\sin i}{\sin r_1}, \quad n_{\text{gw}} = \frac{\sin r_1}{\sin r_2}, \quad n_{\text{ag}} = \frac{\sin r_2}{\sin i}$$

since as the interfaces are parallel

angle of incidence = angle of emergence (i)

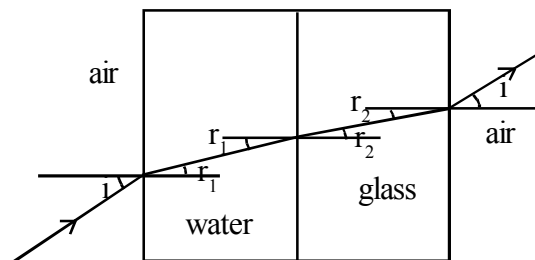

$$n_{wa} \cdot n_{gw} \cdot n_{ag} = \frac{\sin i}{\sin r_1} \cdot \frac{\sin r_1}{\sin r_2} \cdot \frac{\sin r_2}{\sin i}$$

$$n_{wa} \times n_{gw} = \frac{1}{n_{ag}} = \frac{1}{\frac{n_a}{n_g}} = \frac{n_g}{n_a} = n_{ga}$$

$$n_{gw} = \frac{n_{ga}}{n_{wa}}$$

- When light travels from one medium to other its speed, wavelength and intensity changes, while frequency remains same.

$$n_{21} = \frac{n_2}{n_1} = \frac{v_1}{v_2} = \frac{v\lambda_1}{v\lambda_2} = \frac{\lambda_1}{\lambda_2}$$

$\therefore \lambda \propto v \propto \frac{1}{n}$, relation between λ , v and n .

- **Explain refraction through a glass slab**

ABC - Glass Prism

AB, AC, Refracting sides,

BC- Base of the Prism

$\angle A$ Refracting angle of the Prism -

Angle between the refracting sides

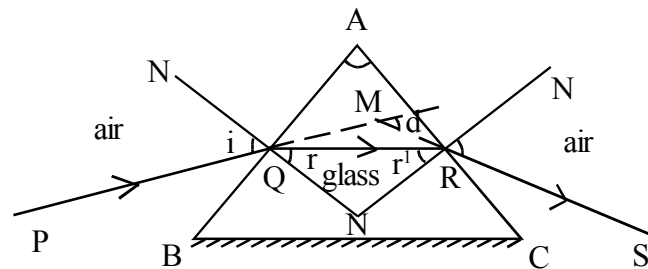

PQ - Incident Ray, QR - Refracted ray, RS - Emergent ray

i, r - angle of incidence and angle of refraction at the interface AB

i', r' - angle of incident and angle of emergence at the interface AC

d - angle between incident ray and emergent ray or refracted ray, called angle of deviation

In the quadrilateral AQMR, $\angle A + \angle QNR = 180^\circ$

From $\triangle QNR$, $\angle r + \angle r' + \angle QNR = 180^\circ$

Hence, $\angle A = \angle r + \angle r'$ ----- (1)

From $\triangle QMR$,

$$d = \angle MQR + \angle MRQ$$

$$d = (i - r) + (i' - r')$$

$$d = (i + i') + (r + r')$$

$$d = (i + i') - (r + r')$$

$$d = i + i' - A \quad \text{----- (2)}$$

- Says, a) Angle of deviation depends on angle of incidence.
 b) As the angle of incidence increases angle of deviation decreases at first then reaches a minimum value then increases.
 c) For an angle of deviation, angle of incidence has two values (i and i')
 d) For a particular angle of incidence, angle of deviation is to be minimum
 The minimum value of angle of deviation is Angle of minimum deviation (D).

When the Prism is at the minimum deviation position the ray passes symmetrically through the Prism. Incident ray, emergent ray are symmetrical with respect to the refracting sides ($i=i'$) and Refracted Ray inside the prism is parallel ($r=r'$) to the base of the Prism - Symmetrical Condition

i.e. At the minimum deviation Position $d=D$, when $i = i'$ and $r = r'$

From eq. (1), $A = 2r$, $D = 2i - A$

$$r = A/2 \qquad i = \frac{A + D}{2}$$

By Snell's law, Refractive index of the material (glass) Prism, $n = \frac{\sin i}{\sin r}$

$$n = \frac{\sin \frac{A + D}{2}}{\sin \frac{A}{2}}$$

i - d curve - A graph between angle of incidence and angle of deviation of glass Prism.

- As the angle of incidence increases angle of deviation decreases and reaches a minimum value and then increases.
- For any angle of deviation, angle of incidence has two values.
- For a particular angle of incidence ($i=i'$) the deviation is found to be minimum called angle of minimum deviation (D)
- A glass prism is placed in water in stead of air, what happens to the angle of minimum deviation.

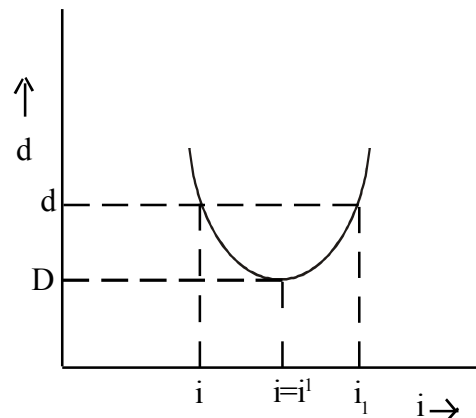

$$\text{In air, } n_{ga} = \frac{\sin \frac{A + D}{2}}{\sin \frac{A}{2}} = \frac{n_g}{n_a}$$

$$\frac{\sin \frac{60+D}{2}}{\sin 30} = \frac{1.55}{1} \quad \therefore D=37^\circ$$

$$\text{In glass, } n_{gw} = \frac{\sin 30+D}{\sin 30} = \frac{n_g}{n_w} = \frac{1.55}{1.33} \quad \therefore D=10^\circ, \text{ decreases}$$

- Explain refraction at a spherical surface

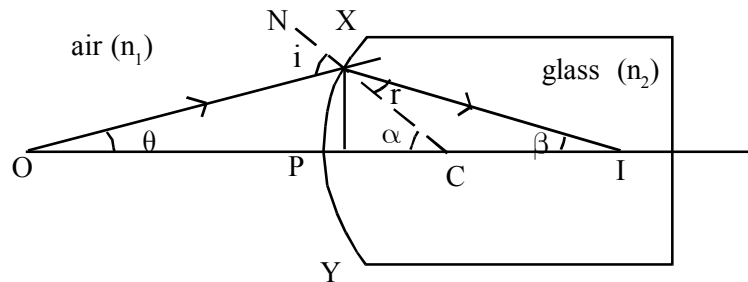

XPY - spherical refracting surface made of glass of refractive index of n_2 . i - Angle of incidence.

r - angle of refraction, O - object, I - real image, C - Centre of curvature, $OP \rightarrow u$ - Object distance

$PI \rightarrow v$ - image distance, $DC \rightarrow R$ - Radius of curvature.

$$\text{From } \triangle OAC, i = \theta + \alpha$$

$$\text{From } \triangle AIC, A = \alpha - \beta$$

If A is very close to P, $i, \theta, \lambda, \alpha, \beta$ are small.

$$\text{From Snells Law, } \frac{i}{r} = \frac{n_2}{n_1}$$

$$n_1 i = n_2 r$$

$$n_1 (\theta + \alpha) = n_2 (\alpha - \beta)$$

$$n_1 \theta + n_1 \alpha = n_2 \alpha - n_2 \beta$$

$$n_1 \frac{AM}{-u} + n_1 \frac{AM}{R} = n_2 \frac{AM}{R} - n_2 \frac{AM}{v}$$

$$\text{Multiplying by } \frac{1}{AM}, \frac{n_1}{-u} + \frac{n_2}{v} = \frac{n_2 - n_1}{R},$$

Spherical Interface equation

Note :

$$\text{From } \triangle OMA, \tan \theta = \frac{AM}{OM}$$

$$\text{If } \theta \text{ is small, } \theta = \frac{AM}{OP} \text{ (For small aperture } OM=OP)$$

$$\theta = \frac{AM}{-u}$$

$$\text{Similarly, from } \triangle AMI \alpha = \frac{AM}{R}$$

$$\text{From } \triangle AMI \beta = \frac{AM}{v}$$

Note : If the object is in glass and the ray is refracted to air, n_1 and n_2 are interchanged.

$$\frac{n_2}{-u} + \frac{n_1}{v} = \frac{n_1 - n_2}{R}$$

- When white light enters in to a glass slab it splits in to different clours. But it comes out of the slabs they combine to form white light. Why?

Equal and opposite refraction at two surfaces.

- Prove the ratio, $\frac{\text{Actual depth}}{\text{Apparent depth}} = n_{\text{denser medium}}$

O - Object under water

OE - Observers eye

I - Image

t - actual depth

t' - Apparent depth

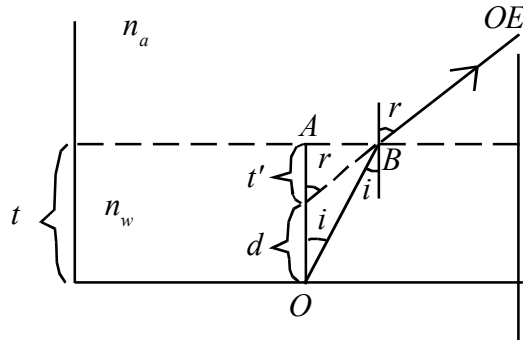

By Snell's law and Principle of Reversibility

$$n_{wa} = \frac{\sin r}{\sin i}$$

$$\text{From } \triangle OAB, \sin i = \frac{AB}{OB}$$

$$\text{From } \triangle IAB, \sin r = \frac{AB}{IB}$$

$$\text{Hence, } n_{wa} = \frac{OB}{IB} \dots\dots\dots (1)$$

When the observer at A, i and r are small. $OB \sim OA$ and $IB \sim IA$

$$n_{wa} = \frac{OA}{IA} = \frac{t}{t'} \quad \text{Apparent swift of the object } d = t - t' = t(1 - \frac{1}{n_{wa}})$$

- Two letters A and B are written, A with red ink and B with Blue Ink, A glass slab is kept on this if viewed from above which letter will appear to be raised more Justify.

Letter B It has lower apparent depth

$$\text{Apparent depth} = \frac{\text{Actual depth}}{n}$$

$$\text{Apparent depth} \propto \frac{1}{n}, \quad \text{But } n \propto \frac{1}{\lambda}$$

$$\lambda_B < \lambda_R \quad \therefore n_B > n_R$$

Hence apparent depth of B is small.

- Define critical angle of medium.

The angle of incidence in denser medium for which the angle of refraction in the rarer medium is 90° .

- Relation between critical angle and refractive index of medium

By Snell's law, $n_{ag} = \frac{\sin c}{\sin 90}$

$$n_{ga} = \frac{1}{\sin c}$$

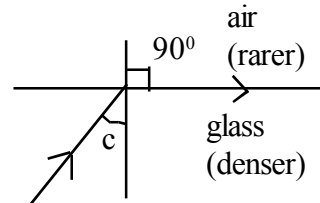

- Define total internal reflection - write its conditions. The phenomenon by which the angle of incidence in the denser medium is greater than the critical angle of the medium the ray of light reflected totally in to the medium.

- Light should travel from denser medium to rarer medium
- Angle of incidence in the denser medium is greater than its critical angle.

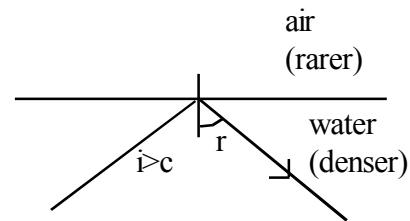

- Absolute refractive index of glass is $3/2$ and water $4/3$. Find the critical angle at glass water interface.

$$n_{gw} = \frac{n_g}{n_w} = \frac{3/2}{4/3} = \frac{9}{8}$$

At the critical angle, $n_{gw} = \frac{1}{\sin c}$

$$\sin c = \frac{8}{9}$$

$$c = \sin^{-1} \left(\frac{8}{9} \right)$$

Write the application of total internal refraction

- 1) Total reflecting Prisms
- 2) Brilliance of Diamond
- 3) Mirage
- 4) Optical Fibre Cable (OFC) - It consists of very long and fine quality glass or Quartz fibres of Refractive Index (1.7) called Core. It is coated with a material of low refractive index 1.5 called cladding.

Different uses of total reflecting Prisms

Total reflecting prism -

Right angled glass prism of critical angle 42°

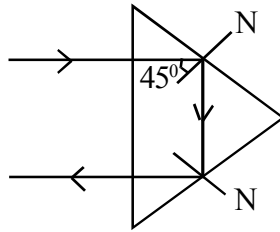

Turned ray of light in to 180°

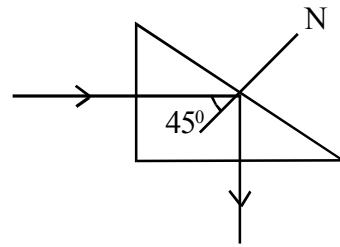

Turned ray of light in to 90°

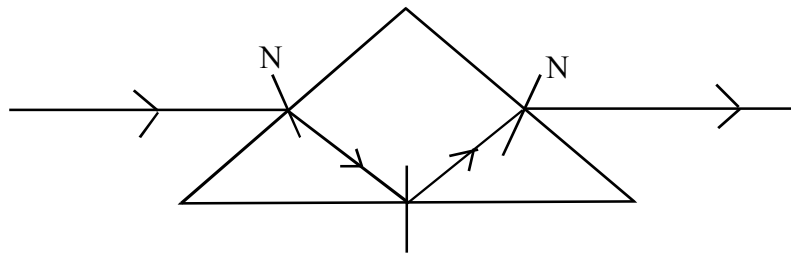

Ray of light passes without bending

- Find the range of angle of incidence with the axis of OFC. So that Total Internal Reflection takes place.

c - critical angle at the core - cladding interface

$$\frac{1}{\sin c} = \frac{n_2}{n_1} = \frac{1.7}{1.5}$$

$$\therefore c=59, \text{ but } c+r=90, \text{ } r=31$$

$$\frac{\sin i}{\sin r} = \frac{n_2}{n_{\text{air}}}, \text{ i.e. } \frac{\sin i}{\sin 31} = \frac{1.7}{1}, \text{ Hence } i=60$$

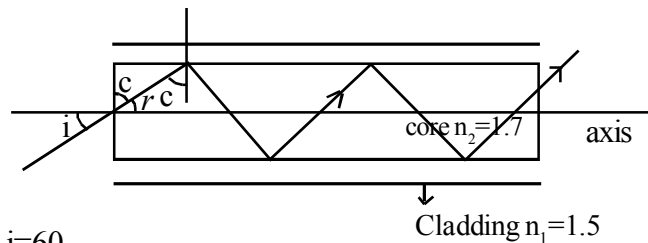

Then all incident rays of angles in the range

$0 < i < 60$ will suffer total internal reflection in the OFC (Light Pipe)

If there is no cladding (air is cladding)

$$c' = \sin^{-1}\left(\frac{1}{1.7}\right) = 37^\circ$$

$$c'+r=90, \text{ Hence } r=53^\circ > c'$$

$$\frac{\sin i}{\sin r} = \frac{n_2}{n_{\text{air}}}, \therefore \frac{\sin i}{\sin 53} = \frac{1.7}{1}, \therefore i=90$$

Thus all incident rays angles in the range $53 < c' < 90$ will suffer total internal reflection.

Explain refraction through a lens

I. Lens Makers formula

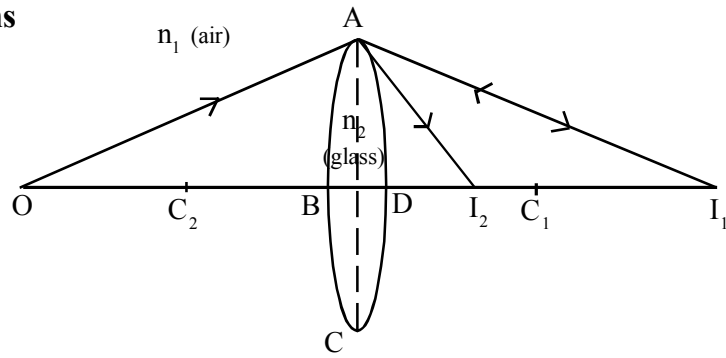

ABCD A: Thin lens, made of glass(n_2), placed in air (n_1)

O - object, $BC_1=R_1$, $DC_2=R_2$, $BI_1=v'$ and $DI_2=v$

- a) Spherical surface ABC forms the image at I_1 (Object is in air and ray of light refracted to glass)

By spherical interface equation,

$$\frac{n_1}{-u} + \frac{n_2}{v'} = \frac{n_2 - n_1}{R_1} \quad \text{----- (1)}$$

- b) Spherical surface of ADC forms the final image at I_2

(Virtual object is in glass and ray of light refracted to air)

$$-\frac{n_2}{v'} + \frac{n_1}{v} = \frac{n_1 - n_2}{R_2} \quad \text{----- (2)}$$

(1) + (2),

$$\frac{n_1}{-u} + \frac{n_1}{v} = n_2 - n_1 \left(\frac{1}{R_1} - \frac{1}{R_2} \right) \quad \text{----- (3) (since the lens within } BI_1=DI_1)$$

When the object is at infinity ($u=\infty$), final image is formed at principal focus ($v=f$)

$$\frac{n_1}{f} = n_2 - n_1 \left(\frac{1}{R_1} - \frac{1}{R_2} \right)$$

$$\frac{1}{f} = \frac{(n_2 - n_1)}{n_1} \left(\frac{1}{R_1} - \frac{1}{R_2} \right)$$

$$\frac{1}{f} = (n_{21} - 1) \left(\frac{1}{R_1} - \frac{1}{R_2} \right)$$

$$\frac{1}{f} = (n - 1) \left(\frac{1}{R_1} - \frac{1}{R_2} \right)$$

After sign convention,

$$\frac{1}{f} = (n - 1) \left(\frac{1}{R_1} + \frac{1}{R_2} \right)$$

where $\frac{n_2}{n_1} = n_{21} = n$

Note :

For Convex lens f +ve, R_1 +ve, R_2 -ve
 For Concave lens f -ve, R_1 -ve, R_2 +ve

II Derive the equation for Law of Distances

$$\frac{n_1}{-u} + \frac{n_2}{v} = (n_2 - n_1) \left(\frac{1}{R_1} - \frac{1}{R_2} \right) \text{ ----- (1)}$$

$$\frac{n_1}{f} = n_2 - n_1 \left(\frac{1}{R_1} - \frac{1}{R_2} \right) \text{ ----- (2)}$$

$$\frac{n_1}{-u} + \frac{n_1}{v} = \frac{n_1}{f}$$

$$\frac{1}{-u} + \frac{1}{v} = \frac{1}{f}$$

III Write the expression for refractive index of the material (glass)lens

(For both convex and concave lens)

$$\frac{1}{f} = (n - 1) \left(\frac{1}{R_1} + \frac{1}{R_2} \right)$$

$$n - 1 = \frac{R_1 R_2}{f(R_1 + R_2)}$$

$$n = 1 + \frac{R_1 R_2}{f(R_1 + R_2)}$$

IV Write the expression for the Power of Lens

Power of lens : Ability to converge or diverge beams of light.

It is the reciprocal of focal length expressed in metre $p = \frac{1}{f}$

$$\frac{1}{f} = (n - 1) \left(\frac{1}{R_1} - \frac{1}{R_2} \right) \quad \text{For convex lens, P is +ve}$$

$$\therefore P = (n - 1) \left(\frac{1}{R_1} - \frac{1}{R_2} \right) \quad \text{For concave lens, P is -ve}$$

- What is the unit of Power of lens

Diopetre (D)

1D is the power of a lens of focal length 1 m

- Difference between power and magnification of a lens.

$$P = \frac{1}{f} \text{ it is constant}$$

$$m = \frac{v}{u} \text{ it is not a constant}$$

- What happens when a convex lens is placed in water ($n_1=1.33$) and carbon di sulphide ($n_1=1.65$) and in glass ($n_1=1.55$)

$$\frac{1}{f} = \left(\frac{n_2}{n_1} - 1\right) \left(\frac{1}{R_1} - \frac{1}{R_2}\right)$$

$$\text{In air, } \frac{1}{f_a} = \left(\frac{n_g}{n_a} - 1\right) \left(\frac{1}{R_1} - \frac{1}{R_2}\right)$$

$$= \left(\frac{1.55}{1} - 1\right) \left(\frac{1}{R_1} - \frac{1}{R_2}\right) = 0.55 \left(\frac{1}{R_1} - \frac{1}{R_2}\right)$$

$$\text{In water, } \frac{1}{f_w} = \left(\frac{n_g}{n_w} - 1\right) \left(\frac{1}{R_1} - \frac{1}{R_2}\right)$$

$$= \left(\frac{1.55}{1.33} - 1\right) \left(\frac{1}{R_1} - \frac{1}{R_2}\right) = 0.17 \left(\frac{1}{R_1} - \frac{1}{R_2}\right)$$

$$= \frac{1/f_a}{1/f_w} = \frac{0.55}{0.17}, \quad f_w = 3.2 f_a \text{ (} f_w \text{ is +ve) acts as converging lens.}$$

$$\text{In Carbon di sulphide, } \frac{1}{f_c} = \left(\frac{n_g}{n_c} - 1\right) \left(\frac{1}{R_1} - \frac{1}{R_2}\right) = \left(\frac{1.55}{1.65} - 1\right) \left(\frac{1}{R_1} - \frac{1}{R_2}\right)$$

$$\frac{1}{f_c} = -0.06 \left(\frac{1}{R_1} - \frac{1}{R_2}\right)$$

$$\frac{1/f_a}{1/f_c} = \frac{0.55}{-0.06}$$

$$f_c = -9.2 f_a \text{ acts as diverging lens. (} f_c \text{ is -ve)}$$

$$\text{If } n_2 = n_1, \frac{1}{f} = 0$$

$$f \Rightarrow \infty, \text{ lens acts as plane glass.}$$

- Compare power of a convex lens in air and water.

$$P_a = \left(\frac{n_2}{n_1} - 1\right)\left(\frac{1}{R_1} - \frac{1}{R_2}\right) = \left(\frac{1.55}{1} - 1\right)\left(\frac{1}{R_1} - \frac{1}{R_2}\right) = 0.55 \left(\frac{1}{R_1} - \frac{1}{R_2}\right)$$

$$P_w = \left(\frac{n_2}{n_1} - 1\right)\left(\frac{1}{R_1} - \frac{1}{R_2}\right) = \left(\frac{1.55}{1.33} - 1\right)\left(\frac{1}{R_1} - \frac{1}{R_2}\right) = 0.17 \left(\frac{1}{R_1} - \frac{1}{R_2}\right)$$

$$\frac{P_a}{P_w} = \frac{0.55}{0.17} = 3.2$$

$$P_{\text{air}} > P_{\text{water}}$$

- Power of sun glasses (cooling) is zero though they have curved surface. Justify

Both the surfaces of sun glasses have the same radius (small thickness)

i.e., $R_1 = R_2 = R$

$$\therefore P = (n-1) \left(\frac{1}{R_1} - \frac{1}{R_2}\right)$$

= 0, so sun glass acts plane glass.

- What are the advantages of lens combination.

- 1) To increase the magnification
- 2) To make the final image erect
- 3) To reduce certain defect of image

Note : Magnification says how much image size is smaller or larger than that of object , $m = \frac{IM}{OB}$

- Explain lens combination

L_1 and L_2 - the two thin lenses of focal lengths f_1 and f_2 respectively.

O - Object, L - Effective lens,

P - Pole, $OP = u$, $PI_1 = v'$, $PI_2 = v$.

By Law of distances,

$$\frac{1}{u} + \frac{1}{v'} = \frac{1}{f_1} \quad \text{----- (1) for lens } L_1$$

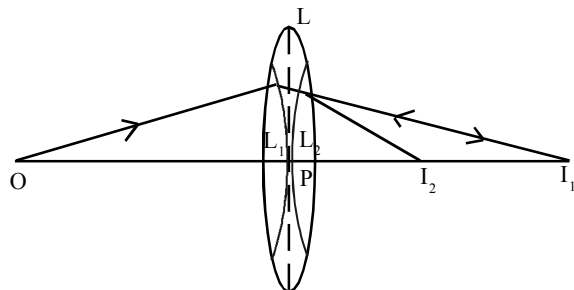

u - object distance
 v' - distance of image I_1
 v - distance of image I_2

$$\frac{1}{-v'} + \frac{1}{v} = \frac{1}{f_2} \text{ ----- (2) for lens } L_2$$

(-ve sign show image formed by L_1 acts as virtual object to L_2)

(1) + (2),

$$\frac{1}{u} + \frac{1}{v} = \frac{1}{f_1} + \frac{1}{f_2} \text{ ----- (3)}$$

If the combination is replaced by a single lens (L) of focal length F

$$\frac{1}{u} + \frac{1}{v} = \frac{1}{F} \text{ ----- (4)}$$

from (3) and (4),

$$\frac{1}{F} = \frac{1}{f_1} + \frac{1}{f_2}, \text{ Effective focal length decreases}$$

- What is the (1) effective focal length, (2) Effective power, (3) Effective magnification

If n - number of identical convex lens of focal length f, power p and magnification m are combined.

$$F = \frac{f}{n}, \quad P = np, \quad M = m^n$$

- What is the effective power of two lenses of focal length f_1 and f_2 are combined.

Since $\frac{1}{F} = \frac{1}{f_1} + \frac{1}{f_2}$

$p = p_1 + p_2$, power increases.

- What is the effective magnification of two lenses of magnification m_1 and m_2 are combined.

$$m = m_1 \cdot m_2$$

- Convex lens of focal length f_1 and concave lens of focal length f_2 are combined what will be the nature of the combination of (1) $f_1 < f_2$, (2) $f_1 > f_2$, (3) $f_1 = f_2$

$$\frac{1}{F} = \frac{1}{f_1} + \frac{1}{-f_2} \text{ (for concave lens } f \text{ is -ve)}$$

$$F = \frac{f_1 f_2}{f_2 - f_1}$$

If $f_1 < f_2$, F is +ve, combination is Converging (convex)

If $f_1 > f_2$, F is -ve, combination is Diverging (concave)

If $f_1 = f_2$, $F = 0$, combination is Plane glass.

- Convex lens ($n=1.5$) is in contact with a liquid layer on the top of a plane mirror. (Called liquid lens arrangement) A small needle with its tip on the principal axis is moved along to the axis until its inverted image is formed at the position of the needle. The distance of the needle from the lens is 45cm. The liquid is removed and the experiment is repeated the new distance is 30cm, What is the refractive index of the liquid.

Note: Ist measurement gives focal length of combination (convex lens and plano concavo liquid lens) by place mirror method.

IInd Measurement gives focal length of the convex lens by Plane mirror method.

$$F = 45 \text{ cm}, f_1 = 30 \text{ cm},$$

$$\frac{1}{45} = \frac{1}{30} + \frac{1}{f_2}, \quad f_2 = -30 \text{ cm} \quad (-\text{ve sign shows liquid lens in concave})$$

To find radius of curvature of concave liquid lens (equal to that of convex lens)

$$\frac{1}{f_1} = \left(\frac{n_2}{n_1} - 1\right) \left(\frac{1}{R_1} - \frac{1}{R_2}\right)$$

$$\frac{1}{30} = \left(\frac{1.5}{1} - 1\right) \left(\frac{1}{R} - \frac{1}{-R}\right)$$

$$\frac{1}{30} = 0.55 \times \frac{2}{R}$$

$$R = 33 \text{ cm}$$

For plano concave liquid lens,

$$R_1 = -33 \text{ cm}$$

$$R_2 = \infty$$

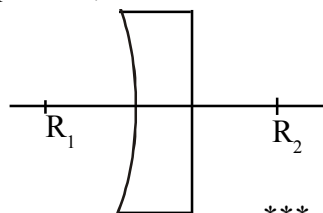

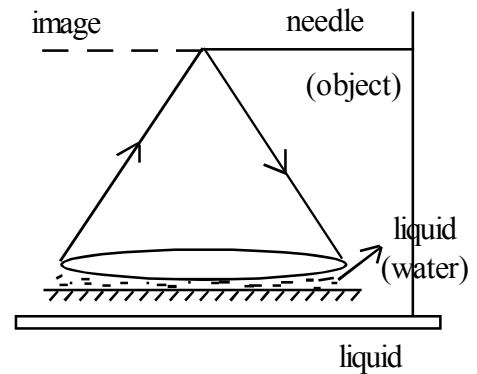

$$\frac{1}{-90} = \left(\frac{n_2}{n_1} - 1\right) \frac{1}{-33}$$

$$\frac{n_2}{n_1} = \frac{33}{90} + 1$$

$$\frac{n_2}{n_1} = n_{\text{liquid, air}}$$

$$n_{\text{liquid, air}} = 1.36$$

Chapter 9

WAVE OPTICS

- Who proposed wave theory of light - Christian Hygens
- What is wave theory - A luminous body is a source of disturbance and the disturbance is propagated in the form of wave and energy is distributed in all directions
- Difference between wave front and Ray -
Wave front is a surface in which particles of the medium vibrate in the same Phase (same amplitude) and are displaced at the same time
Any line Perpendicular to the wave front is a ray along which energy Propagates.

What are Different wave fronts

I Plane wave front - The surface perpendicular to the parallel Rays.

Produced by a far distant source.

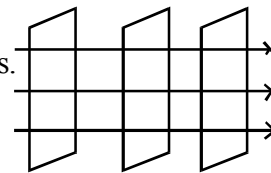

II Spherical wave fronts - Produced by point source.

a) Converging wave fronts. The surfaces perpendicular to the converging rays

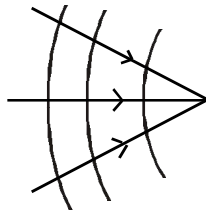

b) Diverging wave fronts -
The surface perpendicular to the diverging rays.

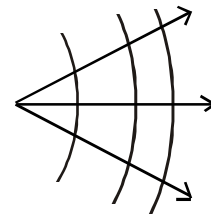

- Write Hygens Principle of wave front
 - 1) Light is propagated in the form of wave
 - 2) Each portion of a wave front moves perpendicular to itself and at the speed of light.
 - 3) In a medium set of straight lines which are perpendicular to the wave fronts are called rays of light along which energy propagates.
 - 4) Every point on a wave front can be regarded as the origin of secondary wave front
- How to construct a wave front if the position of earlier wave front is known.
Consider a number of points on the given wave front, Draw number of spheres of radius ct , with these points as centres. Draw envelop to all these spheres. The envelop will give wave front after the time t . (c - velocity of light)

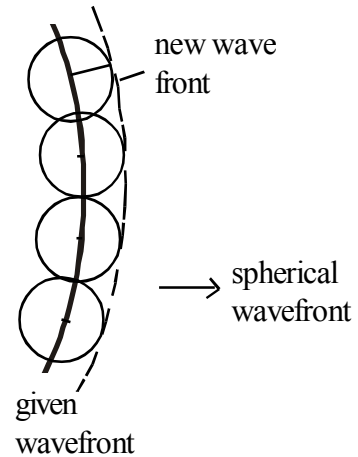
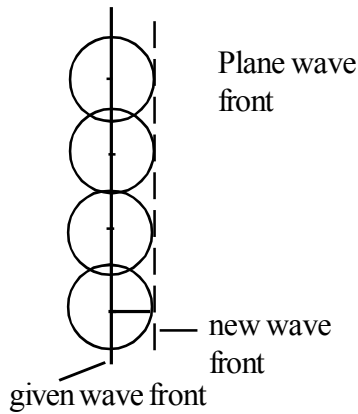

- Explain Law of Reflection on the basis of wave theory

F - Incidenting wave front

F' - Reflected wave front

Po - incident Ray,

oQ - Reflected ray

i - angle of incidence,

r - angle of reflection

Total time taken by F to move to F' along the

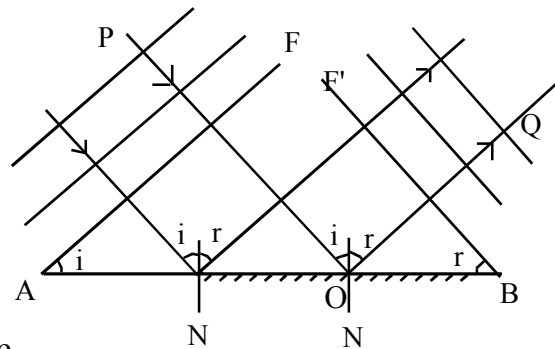

ray POQ is, $t = \frac{PO}{v} + \frac{OQ}{v}$ where 'v' velocity of light in the medium

From the figure $PO = OA \sin i$, $OQ = OB \sin r = (AB - OA) \sin r$

$$t = \frac{OA \sin i}{v} + \frac{AB \sin r}{v} - \frac{OA \sin r}{v}$$

$$t = \frac{AB \sin r}{v} + \frac{OA(\sin i - \sin r)}{v}$$

This time should be same for all rays, The condition for this is

$$(\sin i - \sin r) = 0$$

$$\angle i = \angle r$$

- Explain law of refraction on the basis of wave theory

F - incidenting wave front

F' - Refracted wave front

PO - Incident Ray

OQ - Refracted Ray

i - angle of incidence,

r - angle of refraction

Total time taken by F to move'

F' along the ray POQ is

$$t = \frac{PO}{v_1} + \frac{OQ}{v_2}$$

where v_1 velocity of light in the 1st medium, v_2 -

Velocity of light in the II medium

$$t = \frac{OA \sin i}{v_1} + \frac{(AB - OA) \sin r}{v_2}$$

$$\frac{AB \sin r}{v_2} + OA \left(\frac{\sin i}{v_1} - \frac{\sin r}{v_2} \right)$$

This time should be the same for all the rays. The condition for this

$$\frac{\sin i}{v_1} - \frac{\sin r}{v_2} = 0$$

$$\frac{\sin i}{\sin r} = \frac{v_1}{v_2} = \frac{c}{v_2} = \frac{n_2}{n_1} = n_{21}, \text{ Snells Law of refraction.}$$

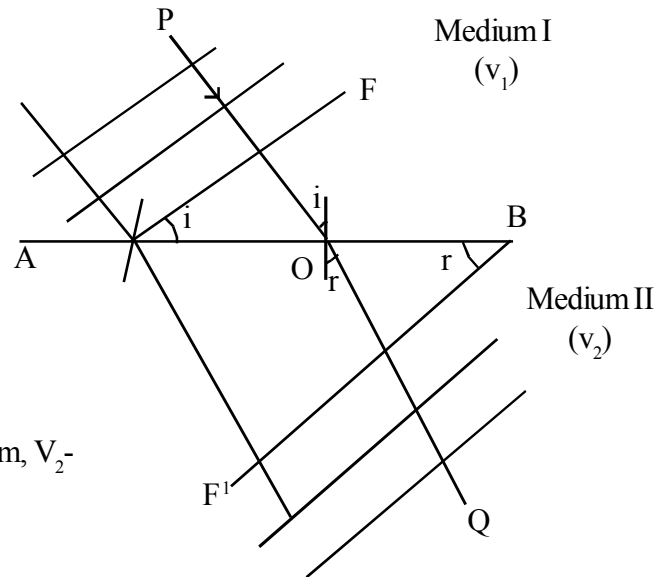

- Explain coherent light sources - write the examples.

Two light sources which emit light waves having same Frequency, Amplitude and Zero / Constant phase difference.

Eg : Youngs double slit - Light coming from two parallel and close slits on an opaque screen illuminated by a narrow slit which is brightened by a light source.

Lloyd's Mirror : A light source and its mirror image

- What is interference - The effect produced in a region of space by the superposition of two or more identical waves.

These are two types,

Constructive interference - The resultant displacement (Amplitude) of two identical waves after Super position is maximum.

A - Amplitude of electric field vector of each wave,

Resultant Displacement = $A+A$

Intensity $I = (2A)^2$

Note:- Electric field vector is used to represent monochromatic (single frequency) light.

Destructive Interference - The resultant displacement (Amplitude) of two identical waves after super position is zero(min). Resultant displacement = $A-A$ ∴ Intensity = 0

- What is the interference pattern - Alternative maximum intensity and minimum intensity.
- What is sustained interference write the condition for it.

The interference pattern in which the positions of maximum and minimum intensities do not change with time.

Conditions :

- 1) The sources of light must be coherent
 - 2) The sources must be narrow and close to each other
 - 3) They should emit light continuously
 - 4) The Screen must be comparately at large distance from the coherent sources.
- Write the conditions for constructive interference and destructive interference

For constructive interference

Phase difference between two waves, $\theta = 2n\pi$, where $n = 0, 1, 2, 3, \dots$

Path difference between two waves, $\delta = n\lambda$ where $n = 0, 1, 2, 3, \dots$

For destructive interference,

Phase difference, $\theta = (2n+1)\pi$ where $n = 0, 1, 2, 3, \dots$

Path difference, $\delta = (2n+1)\frac{\lambda}{2}$

- Relation between Path difference and Phase difference

Phase difference, $\theta = 2\pi = \lambda = \delta$, Path difference

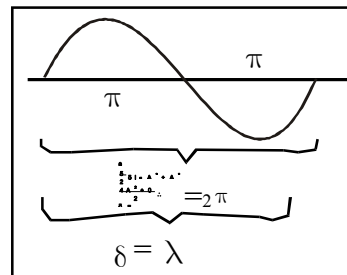

For unit wavelength, phase difference $\theta = 2\pi/\lambda$

For Path difference δ , Phase difference $\theta = 2\pi/\lambda \cdot \delta$

- Draw variation of intensity (I) of light due to double slit.

Intensity of light due to double slit is in between 0 (min) and 4 times (max) the contribution of single slit

A - Amplitude of light wave from each slit

Intensity of light due to double slit : $I \propto A^2 + A^2 = 2A^2$

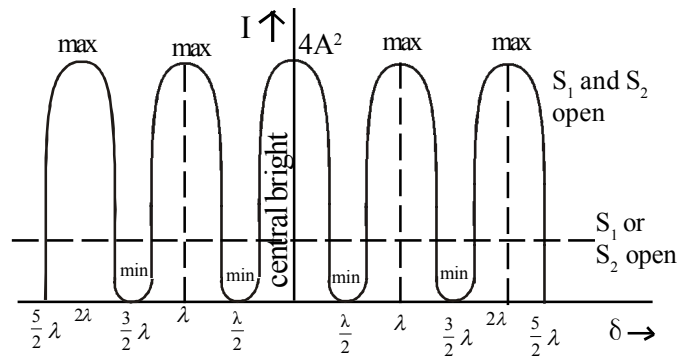

For constructive interference

the resultant amplitude = A+A

Intensity of light due to constructive interference, $I \propto (2A)^2 = 4A^2$

For destructive interference the resultant amplitude = A - A

Intensity of light due to destructive interference = 0

Hence average intensity of light after interference = $\frac{4A^2 + 0}{2} = 2A^2$

So interference is the redistribution of energy keeping total energy is constant

i.e. energy is conserved.

- Relation between the width of a slit (w) and intensity of light

$$I \propto W$$

- The amplitude of light waves from two slits are in the ratio 2:1.

What is the ratio of their width?

$$I_1 : I_2 = A_1^2 : A_2^2 = W_1 : W_2$$

$$\therefore W_1 : W_2 = 4 : 1$$

- Write the expression for path difference and band width of interference

S_1S_2 - double slit, S - narrow slit arranged

on the perpendicular bisector of S_1S_2

$S_1S_2=d$, distance between the slits, $OO' =$

D - Distance of the screen from the double slit

P - a point on the screen $OP = x$

Path difference between two rays proceeding from S_1 and S_2 on arriving at the point P is

$$\delta = S_2P - S_1P = S_2N$$

from $\triangle S_1NS_2$, $\sin \theta = \frac{S_2N}{d}$

from $\triangle OO'P$ $\sin \theta = \frac{x}{OP} \sim \frac{x}{OO'} = \frac{x}{D}$ ($\because x$ is very small)

$$\frac{S_2N}{d} = \frac{x}{D}$$

Path difference $\delta = \frac{x \cdot d}{D}$

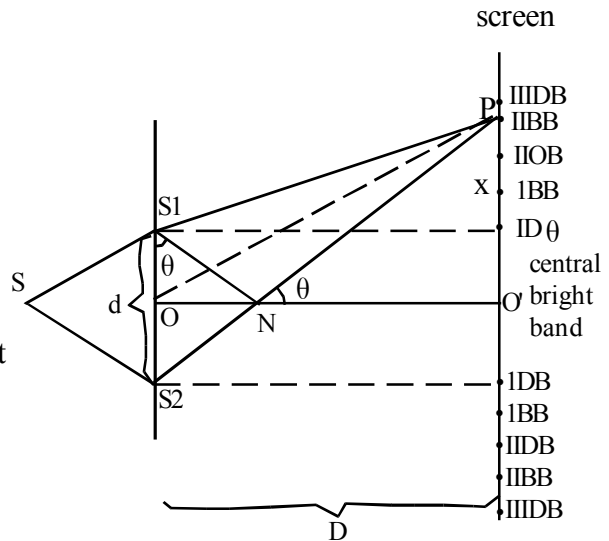

For constructive interference, $\delta = \frac{xd}{D} = n\lambda$ where $n=0, 1, 2, 3, \dots$

when $n=0$, $\delta=0$, All rays from S_1 and S_2 joined together at O' formed central bright band.

when $n=1$, $\frac{x_1d}{D} = \lambda \therefore x_1 = \frac{\lambda D}{d}$, distance of First Bright Band from central bright band.

when $n=2$, $\frac{x_2d}{D} = 2\lambda \therefore x_2 = \frac{2\lambda D}{d}$, Distance of 2nd BB from central BB.

When $n=3$, $\frac{x_3d}{D} = 3\lambda \therefore x_3 = \frac{3\lambda D}{d}$, Distance of 3rd BB from central BB.

..... etc.

Distance between two adjacent Bright Bands. $\beta = x_2 - x_1 = \frac{\lambda D}{d}$ called Bandwidth

For destructive interference, $\delta = (2n+1) \frac{\lambda}{2}$ where $n=0, 1, 2, 3, \dots$

when $n=0$, $\frac{x_1 d}{D} = \frac{\lambda}{2}$, $\therefore x_1 = \frac{1}{2} \frac{\lambda D}{d}$, distance of 1st DB from CBB (lies in between CBB and IBB)

when $n = 1$, $\frac{x_2 d}{D} = \frac{3}{2} \lambda$ $\therefore x_2 = \frac{3}{2} \frac{\lambda D}{d}$, Distance of 2nd DB from CBB. (lies in between IBB and IIBB)

when $n = 2$, $\frac{x_3 d}{D} = \frac{5}{2} \lambda$ $\therefore x_3 = \frac{5}{2} \frac{\lambda D}{d}$, Distance of 3rd DB from CBB. (lies in between IIBB and IIIBB)

..... etc.

Distance between two adjacent dark Bands called Band width (fringe width)

$$\beta = x_2 - x_1 = \frac{\lambda D}{d}$$

- Calculate width of CBB - it is the distance between 1st DB on either side of CBB

$$\beta = \frac{1}{2} \frac{\lambda D}{d} + \frac{1}{2} \frac{\lambda D}{d} = \frac{\lambda D}{d}$$

- When we immerse the Youngs double slit apparatus (Demonstration of interference of light) in a liquid of refractive index n -
What will be the fringe width?

In air, $\beta = \frac{\lambda D}{d}$

In a liquid, $\beta = \frac{\lambda' D}{d}$ (only wavelength changes)

But, $\frac{\lambda}{\lambda'} = \frac{c}{v} = \frac{n}{n_{\text{air}}}$ (using $\frac{\lambda_1}{\lambda_2} = \frac{v_1}{v_2} = \frac{n_2}{n_1}$)

$$\lambda' = \frac{\lambda}{n}, \text{ since } n_{\text{air}} = 1$$

$$\beta' = \frac{\lambda D}{n d}, \beta' = \frac{\beta}{n}, \text{ decreases,}$$

- In young's double slit experiment slits are 0.2mm apart and screen is 1.5m away. It is observed that the distance between CBB and fourth bright Band is 1.8cm. Calculate the wave length of light used.

$$4\beta = 1.8 \times 10^{-2} \text{ m}$$

$$4 \frac{\lambda D}{d} = 1.8 \times 10^{-2} \text{ m}$$

$$\lambda = \frac{1.8 \times 10^{-2} \times 0.2 \times 10^{-2}}{4 \times 1.5} = 0.6 \times 10^{-6} \text{ m}$$

- What is diffraction of light - The phenomenon of bending of light around an opaque obstacle. Who explained diffraction of light. Fresnel explained diffraction on the basis of wave theory.

- Explain diffraction of light at narrow slit

AB - narrow slit of width a , θ - angle of diffraction, P - a point on the screen at a distance x from O. Path difference between the rays

coming from top and bottom of the slit on arriving at the point P is $\delta = BP - AP = BN = a \sin \theta$

$$\delta = a \theta = \frac{xa}{D} \quad (\theta \text{ is small})$$

Condition for diffraction $a \theta = n \lambda$

$$\therefore \theta = \frac{n \lambda}{a} \quad \text{where } n = 0, 1, 2, 3, \dots$$

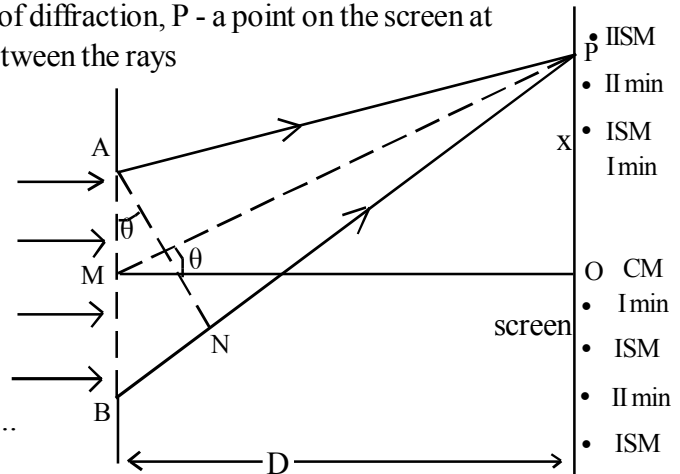

- I When $n = 0$, $\theta = 0$. All the rays coming from AB joined together at O.

This gives max intensity at O called central maximum (CM)

- II The point P becomes dark (minima), Path difference, $Q\theta = \pm n \lambda$

$$\begin{aligned} \Delta MOP, \sin \theta &= \frac{x}{D} \\ \Delta ABN, \sin \theta &= \frac{BN}{a} \\ BN &= \frac{xa}{D} \end{aligned}$$

When $\theta = \pm \frac{n \lambda}{a}$ where $n = 1, 2, 3, \dots$ called Ist, IInd, IIIrd.... minima (M) are formed on either side of the central max.

- III The point P becomes less intense max (secondary max)

Path difference, $a \theta = (2n+1) \frac{\lambda}{2}$

$$\text{Then } \theta = \frac{(2n+1) \lambda}{2a}, \quad n = 1, 2, 3, \dots \text{ called I}^{\text{st}}, \text{II}^{\text{nd}}, \text{III}^{\text{rd}} \dots$$

Secondary Max (SM) are formed on either side central max, but in between two minima.

- Draw variation of intensity of light with angle of diffraction due to a narrow slit.

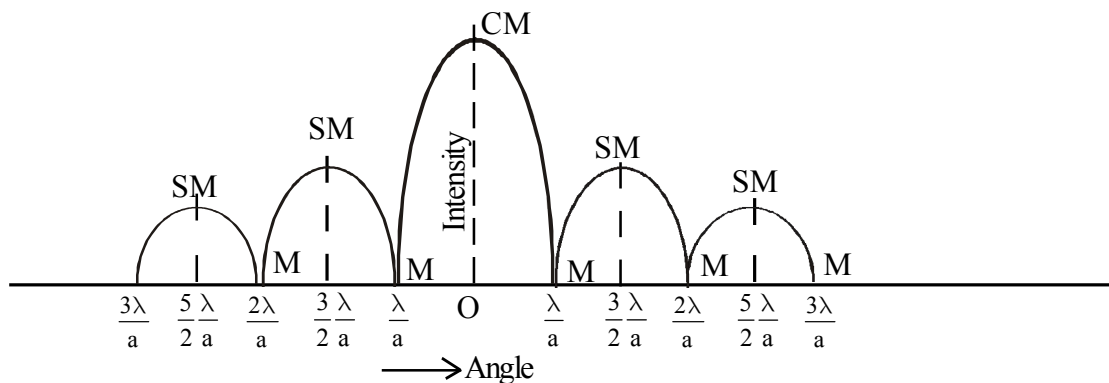

Note : As n increases intensity decreases.

- Calculate the width of diffraction minimum.

For nth minimum, $a \theta_n = \frac{x_n a}{D} = n \lambda$

$$x_n = \frac{n \lambda D}{a}, \text{ Distance of nth minimum from central maximum.}$$

Distance of (n+1)th minimum, $x_{(n+1)} = (n+1) \frac{\lambda D}{a}$

\therefore Width of minimum, $x_{n+1} - x_n = \beta$

$$\therefore \beta = \frac{\lambda D}{a}$$

- Calculate the width of diffraction SM

for nth SM, $a \theta_n = \frac{x_n a}{D} = \frac{(2n+1)}{2} \lambda$

$$x_n = \frac{(2n+1)}{2} \frac{\lambda D}{a}, \text{ distance of nth SM from central maximum.}$$

Distance of (n-1)th minimum, $x_{(n-1)} = \frac{[2(n-1)+1] \lambda D}{2 a}$

\therefore Width of SM, $\beta = x_n - x_{n-1}$

$$\beta = \frac{\lambda D}{a}$$

- Calculate the width of Central Max.

It is the distance between 1st minimum on either side of central maximum

\therefore Width of central max, $\beta' = 2x_1$, where $x_1 = \frac{\lambda D}{a}$

$$= 2 \frac{\lambda D}{a} = 2\beta$$

- What is the condition for complete polarisation of reflected ray?
Angle between reflected ray and refracted rays is 90
- State and explain Brewsters law

Tan of angle of incidence corresponding to complete polarisation is equal to refractive index of medium.

$$i_p + 90 + r = 180$$

$$r = 90 - i_p$$

By Snell's law,

$$n_{wa} = \frac{\sin i_p}{\sin r} = \frac{\sin i_p}{\sin (90 - i_p)}$$

$$n_{wa} = \frac{\sin i_p}{\cos i_p} = \tan i_p$$

In general, $n = \tan i_p$

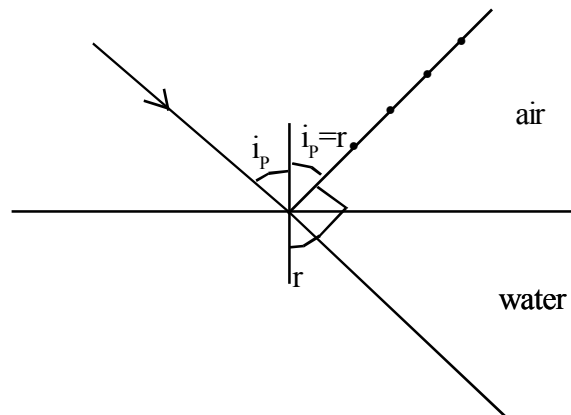

- What is Polarisation of light : Oscillation of Electric field vector (rep. of light) in transverse plane.
- Unpolarised light - \vec{E} and \vec{B} vibrate in infinity direction.
- Can sound wave get polarised?

No.

- Angle of incidence is equal to polarising angle. (i_p) Show that RR and RR' are mutually perpendicular.

$$n = \tan i_p = \frac{\sin i_p}{\cos i_p} = \frac{\sin i_p}{\sin r}$$

$$\cos i_p = \sin r$$

$$\sin (90 - i_p) = \sin r$$

$$90 - i_p = r$$

$$i_p + r = 90$$

Angle between RR and RR' is 90.

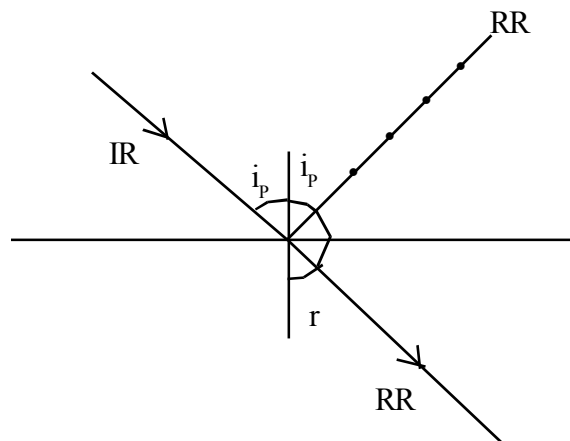

- Which property of light reveals light in Transverse in wave nature Polarisation
- What is polaroid write examples.

A synthetic substance in which the intensity of light is reduced to half

eg: Tourmaline crystal, Nicol Prism, Sugar Solution.

- Critical angle of glass is 40° calculate the Polarising angle. (Polarising Angle - Angle of incidence at which the reflected ray of completely polarised.)

$$n = \frac{1}{\sin c}, \quad n = \tan i_p$$

$$i_p = \tan^{-1}\left(\frac{1}{\sin c}\right)$$

$$= \tan^{-1}\left(\frac{1}{\sin 40}\right) = 56^\circ$$

- What is Doppler effect of light

The apparent change in frequency of light due to relative motion of the source and observer

Apparant frequency, $\nu' = \nu \left(\frac{c - v_o}{c - v_s}\right)$, where ν - actual frequency light

v_o - speed of observer

v_s - speed of source

c - velocity of light.

Case

- 1) Source is at rest observer move towards the source

$$\nu' = \nu \left(1 + \frac{v_o}{c}\right) \text{ increases}$$

- 2) Observer at rest source moves towards the observer

$$\nu' = \nu \left(1 + \frac{v_s}{c}\right) \text{ increases}$$

- 3) Source is at rest, observer receds from the source

$$\nu' = \nu \left(1 - \frac{v_o}{c}\right) \text{ decreases}$$

- 4) Observer at rest, source receds from the observer

$$\nu' = \nu \left(1 - \frac{v_s}{c}\right) \text{ decreases}$$

- 5) Source and observer approach each other.

$$\nu' = \nu \left(\frac{c + v_o}{c - v_s}\right) \text{ increases}$$

Chapter 10

DUAL NATURE OF MATTER AND RADIATION

Introduction

Light exhibit dual nature - wave nature and particle nature. In Phenomena like Interference, diffraction etc wave nature is exhibited. In photo electric effect, Compton effect etc particle nature is observed. Thus light exhibit wave - particle duality.

Matter can also exhibit dual nature. Moving particle like electrons, protons etc can exhibit wave properties.

- **What is Photoelectric effect? Explain the laws of Photoelectric effect.**

Photoelectric effect was discovered by Hertz in 1887. When light of suitable frequency is incident on certain metals free electrons are emitted from the metal. This process is called photoelectric effect. Generated electrons are called photoelectrons and current due to this is called photoelectric current.

Ordinary metal shows this effect when UV rays falls on them. But alkali metals like Potassium, Sodium etc exhibit this effect even with visible light.

Laws of Photo electric emission

1. For a given metal there is a minimum frequency called threshold frequency for incident radiation, below which there is photo electric emission, however high the intensity is
 2. For a given metal, the photoelectric current directly proportional to intensity of incident radiation provided frequency is higher than threshold frequency
 3. The KE of the photoelectrons depends on the frequency of the incident radiation.
 4. Photoelectric emission is an instantaneous process. ie there is no time lag between incident radiation and emission of photoelectron.
 5. KE of photo electrons almost independent of intensity.
- What is saturation current?
 - What is stopping potential? Does it change with intensity of light.

Maintain the anode A at some accelerating potential and cathode C is illuminated with light of intensity I_1 . When the accelerating potential increases the photo electric current also increases and become maximum.

This maximum value of photoelectric current is called saturation current for that intensity. This saturation current increases with increase in intensity.

Now apply retarding (-ve) potential to anode A with respect to C. When this retarding potential increases, the photo current decreases and becomes zero at a particular retarding potential (V_0).

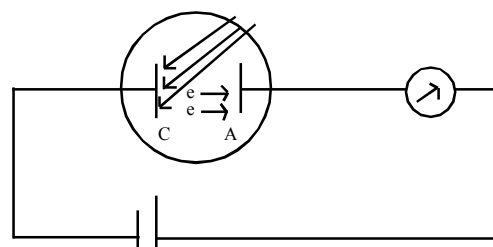

The minimum retarding potential given to anode for which photoelectric current become zero is called stopping potential (V_0). Stopping potential is the same for all intensities. It doesn't depend on intensity of light. $KE_{\max} = eV_0$ (Max KE of photo electrons)

● **Einstein's Photo electric Equation**

Einstein gave explanation to photo electric effect based on quantum theory of light. The emission of electron is as a result of interaction of single photon with an electron, in which the photon is completely absorbed by the electron.

To remove an electron from the metal, a certain minimum energy called work function (ϕ) is required.

∴ By law of conservation of energy

Energy of incident photon = Work function + KE of emitted electron

ie. $h\nu = \phi + \frac{1}{2}mv^2$ (1)

$\frac{1}{2}mv^2 = h\nu - \phi$

When $\nu = \nu_0$, KE = $\frac{1}{2}mv^2 = 0$

$0 = h\nu_0 - \phi$

ie. $\phi = h\nu_0$

∴ eqn (1) becomes

$h\nu = h\nu_0 + \frac{1}{2}mv^2$

or $\frac{1}{2}mv^2 = h(\nu - \nu_0)$

This is Einstein's Photo electric equation. Says (1) Kinetic Energy of Photo electrons depends on frequency (ν) (2) $\nu < \nu_0$ Photo electric emission is impossible.

Note : $\nu = \frac{c}{\lambda}$ $\nu_0 = \frac{c}{\lambda_0}$

∴ $\frac{1}{2}mv^2 = h\left(\frac{c}{\lambda} - \frac{c}{\lambda_0}\right)$

$\frac{1}{2}mv^2 = hc\left(\frac{1}{\lambda} - \frac{1}{\lambda_0}\right)$, Photo Electric Emission (PEE) in terms of wavelength.

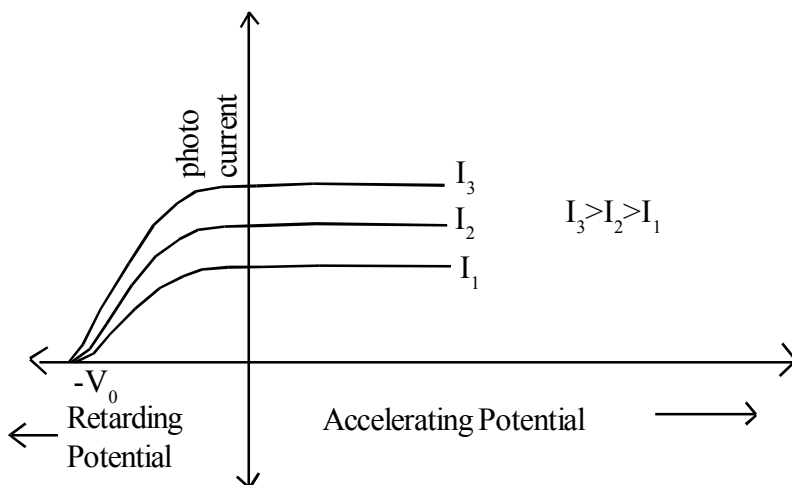

- What is the effect of frequency of incident radiation on stopping potential?
For a particular intensity of light, the stopping potential is more negative for higher frequency of incident radiation

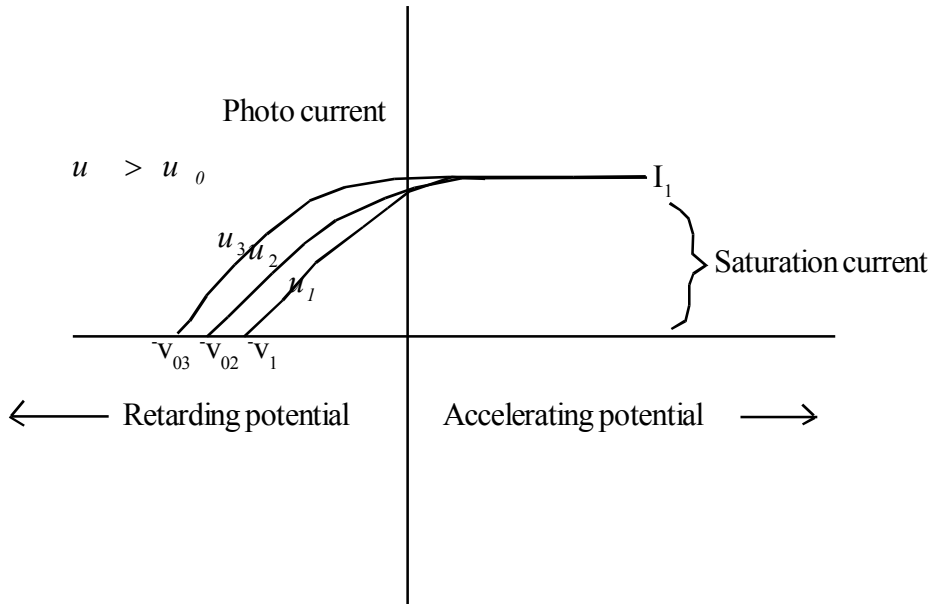

Below is the graph showing the variation of stopping potential with frequency of incident radiation.

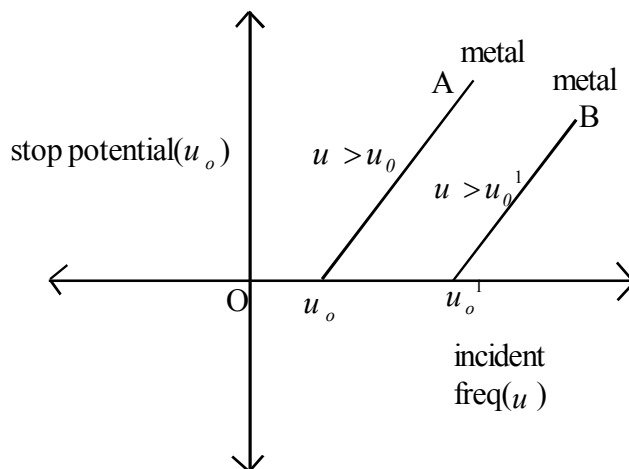

Note :

If V_0 is the stopping potential

$$\frac{1}{2}mv^2 = eV_0$$

\therefore Einstein's Photo electric eqn

$$eV_0 = h(u - u_0)$$

$$\text{or } V_0 = \frac{hu}{e} - \frac{hu_0}{e}$$

Comparing with $y = mx + c$

Slope of frequency (ν) - Stopping potential V_0 graph is,

$$m = \frac{h}{e}, \text{ Slope} \times e = h, \text{ Planks constant.}$$

$$\text{y intercept } c = \frac{-h\nu_0}{e}$$

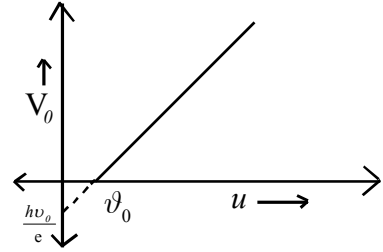

- What will be the max. KE of photo electrons emitted from magnesium ($\phi = 3.7\text{eV}$) when uv of $\lambda = 1.5 \times 10^{-7}\text{m}$ is incident.

$$h\nu = 6.6 \times 10^{-34} \times 1.5 \times 10^{15} = 9.9 \times 10^{-19} \text{ J}$$

$$\phi = 3.7 \text{ eV} = 3.7 \times 1.6 \times 10^{-19}$$

$$\therefore \frac{1}{2} m v_m^2 = 9.9 \times 10^{-19} - 3.7 \times 1.6 \times 10^{-19} = 3.98 \times 10^{-19} \text{ J}$$

$$= 2.5 \text{ eV}$$

Evaluation

- Monochromatic radiation of wave length 640.2nm from Neon lamp irradiates a phot sensitive material made of cesium on tungsten. The stopping voltage is measured to be 0.54V. The source is replaced by source of 427.2nm irradiating the same photo cell. What is the new stopping potential.

Wave Nature of matter - Matter Waves

In 1924 Louis de Broglie proposed that moving particle of matter shows wave - like property under suitable condition. This wave associated with moving particle is called matter wave.

De Broglie wave length :

The wave length associated with a particle of mass 'm' moving with a speed v is given by

$$\lambda = \frac{h}{p} = \frac{h}{mv} \text{ Where h is planks constant.}$$

This wave length is called de Broglie wave length associated with matter wave.

- De Broglie wave length of electron

Consider on electron of mass 'm' accelerated from rest through a pd of V volts. The KE of electron, $K = eV$

$$\text{but } K = \frac{1}{2}mv^2 = \frac{p^2}{2m}$$

$$\therefore p = \sqrt{2mk} = \sqrt{2meV}$$

\therefore De Broglie wave length of electron

$$\lambda = \frac{h}{p} = \frac{h}{\sqrt{2meV}}$$

Substituting h, e, n, m

$$\lambda = \frac{1.227}{\sqrt{V}} \text{ nm}$$

- Define work function of a metal

The minimum energy required to liberate an electron from the surface of the metal.

$w = h \nu_0$ where $h = 6.63 \times 10^{-34}$ JS. ν_0 - Threshold frequency - Frequency of the incident radiation for which electron emission just starts.

- What is the unit of work function - Electron Volt (eV)
- What are the methods used for supplying work function.

Thermonic emission (Supplying Heat energy)	Electric field emission, (Supplying electric field)	Photo electric emission (Incidenting Light)
---	--	--

- Work function of A is 1.92 eV and B is 5eV which of them is photo emission for a radiation wavelength 3300⁰A.

Note: $\nu_0 < \nu$ - the metal is photo emissive

$$\nu = 9 \times 10^{14} \text{g}$$

$$\nu = \frac{c}{\lambda} = \frac{3 \times 10^8}{3300 \times 10^{-10}} = 9 \times 10^{14} \text{ Hz}$$

$$\nu_0(\text{A}) = \frac{w}{h} = \frac{1.92 \times 1.6 \times 10^{-19} \text{ J}}{6.63 \times 10^{-34}} = 5 \times 10^{14} \text{ Hz, Photo emissive}$$

$$\nu_0(\text{B}) = \frac{w}{h} = \frac{5 \times 1.6 \times 10^{-19} \text{ J}}{6.63 \times 10^{-34}} = 12 \times 10^{14} \text{ Hz, not photo emissive}$$

- Condition for Photo electric emission - $\nu > \nu_0$ or $\lambda < \lambda_0$
- Alkali metals are suitable for Photo electric emission
Work function of alkali metal is small.
- Which photon is more energetic Red or Violet - Justify.
Violet since $KE \propto \nu$, ν of violet is greater than that of Red.
- Explain Photo electric Cell : Device which converts change in intensity of light into corresponding change in electric current.

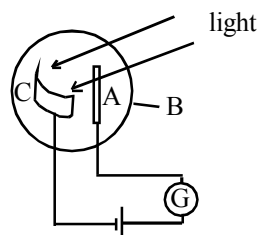

B - Evaluated Glass bulb

C - Emitter - A metallic plated coated with photo sensitive material (sodium oxide)

A - Anode (Nickel Rod)

- Photo electric cell is called "Electric Eye" - It responds to the light falling on it, like eye.
- Uses of photo electric cell.
 - 1) Used to measure intensity of light (Measures rate of flow of Photons)
 - 2) Automatic switching of street light.
 - 3) Conversion of solar energy into electrical energy (Solar cell)

- Explain matter waves or de-Broglie waves.

Waves associated with material particles. Eg.: Electron, Proton, Neutron.

- Express the relation for de-broglie wave length.

Consider a photon of mass m moving with the velocity c

Energy of photon, $E = mc^2 = h\nu$ where ν - frequency photon.

$$m = \frac{h\nu}{c^2}$$

$$\text{Momentum of photon } P = mc = \frac{h\nu}{c} = \frac{h}{\lambda}$$

$$\text{de-Broglie wavelength of photon } \lambda = \frac{h}{p}$$

In general, the de-Broglie wavelength associated with a material particle of mass m moving

with velocity. $\lambda = \frac{h}{p} = \frac{h}{mv}$ - It connects momentum (P) and wave length λ

- De-Broglie waves are always associated with a moving particle. If $v=0$ then de-Broglie wave length $\lambda = \infty$, infinity.

- Write the application of wave nature of matter

Electron microscope having high resolving power designed by Ernest Ruska.

- Why de-Broglie waves associated with a moving train is not visible.

$$\text{Since } \lambda = \frac{h}{mv}, \quad \therefore \lambda \propto \frac{1}{m}$$

Mass (m) of the train is large λ is very small.

Davison and Germer Experiment

Davison and Germer in 1927 succeeded in measuring De Broglie wave length associated with an electron. A beam of electrons emitted from a heated filament F is accelerated by applying p.d V between the filament and cylinder. The beam is now narrowed by passing it through two slits s_1 & s_2 and strikes the target T of Nickel crystal. The electrons are scattered in all direction by the target.

The intensities of scattered electron beam in a given direction is measured by an electron detector which is connected to a galvanometer. The current in the galvanometer is a measure of intensity of diffracted electron beam. The observations are repeated for various accelerating potential and angle of scattering. The intensity of diffracted beam is maximum at 54V for angle $\phi = 50^\circ$

From electron diffraction measurement wave length of matter wave was found to be 0.165nm.

$$\begin{aligned} \lambda \text{ of electron using eqn is } \lambda &= \frac{1.227}{\sqrt{V}} \text{ nm} \\ &= \frac{1.227}{\sqrt{54}} = 0.167 \text{ nm} \end{aligned}$$

Thus there is an excellent agreement between theoretical and experimentally observed value. Thus Davison and Germer expt. confirms the wave nature of electron and de Broglie relation.

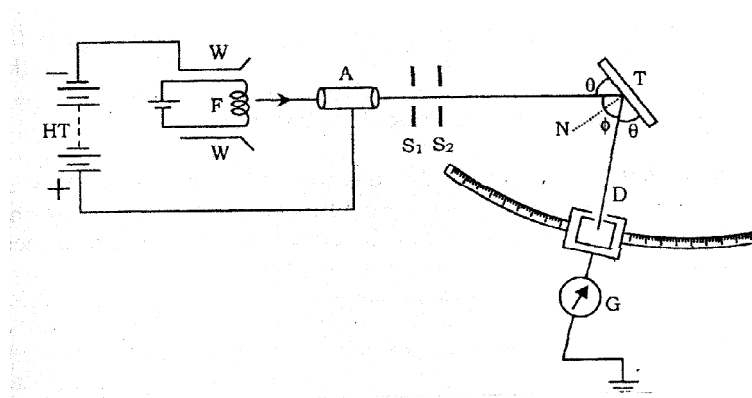

Chapter 11

ATOMS

Explain Thomson's atom model

J.J. Thomson was the first scientist to propose a model of atom. According to this model - The entire positive charge of the atom was uniformly distributed in a sphere and electrons were embedded in such a manner that their mutual repulsions were balanced by attractive force by +ve charges.

This atom model is known as plum pudding model (water melon model)

This model could not explain stability and emission spectra of atoms.

- What are the conclusions of Rutherford's α particle scattering experiment.

In α particle scattering experiment, α particles from a source made in to a beam and was allowed to fall on a thin gold foil. The scattered α particles were observed through a rotatable detector consisting of zinc sulphide screen and a microscope. α particles on striking the screen produced scintillations. Using this a arrangement number of scattered α particles were studied as function of angle of scattering. The main observations were

- a. Most of the α particles came out of they gold foil without suffering any deviation from their straight line path. This shows that most region of the atom is hollow.
- b. A few α particles collided with atoms of gold foil suffered large deflection. A very few α particles even turned back towards the source itself. This showed that the entire +ve charge and almost the whole mass of the atom is concentrated in a small region called nucleus at the centre of the atom.

Explain Rutherford's model of the atom

According to this model

- a. The entire positive charge of the atom is concentrated in a small region called nucleus, at the centre of the atom.
- b. The electrons revolves round the nucleus. The coulomb's force of attraction between nucleus and electrons provides the necessary centripetal force for the revolution of electrons.

Drawbacks

According to classical electromagnetic theory a revolving electron (accelerated charge) should radiate energy continuously and thus electron should spiral inward and finally fall in to the nucleus. Thus this model could not explain the stability of atom.

As the energy of revolving electron decreases continously the atom should give a continuous spectrum. Thus this model fails to explain the line spectra of atoms.

Explain the postulates of Bhor's atom model

Bhor modified Rutherford's atom model on the basis of Quantum theory of radiation. The postulates of Bhor atom model are.

- a. An electron in an atom could revolve in certain stable orbits without the emission of radiant energy. According to this postulate each atom has certain definite stable states in which it can exist, and each possible state has definite energy. These are called stationary states of the atom.
- b. Electron revolves round the nucleus only in those orbits for which angular momentum is integral multiple of i.e. $\frac{h}{2\pi}$ (where h is plank's constant)
 $n=1, 2, 3, \dots$ are called principle Quantum Number
- c. When an electron jumps from a higher stable orbit to lower stable orbit, the energy difference is radiated in the form of a photon of energy.

$$h\nu = E_i - E_f$$

Where E_i - energy of higher stable orbit.

E_f - energy of lower stable orbit.

Radius of nth orbit (hydrogen atom)

For a hydrogen atom (1 proton 1 electron)

$$\frac{mv^2}{r} = \frac{1}{4\pi\epsilon_0} \frac{e^2}{r^2}$$

m - mass of electron

v - speed of electron

r - radius of orbit

$$r = \frac{e^2}{4\pi\epsilon_0 mv^2}$$

For nth orbit $r_n = \frac{e^2}{4\pi\epsilon_0 mv^2} \dots\dots\dots(1)$

According to Bohr's postulate for the nth orbit, angular momentum.

Angular momentum $L_n = \frac{nh}{2\pi}$

i.e. $mV_n r_n = \frac{nh}{2\pi} \dots\dots\dots(2)$

Using (2) Eqn (1) becomes

$$r_n = \frac{e^2}{4\pi\epsilon_0 m \left(\frac{nh}{2\pi m r_n} \right)^2}$$

Rearranging or $r_n = \frac{n^2}{m} \left(\frac{h}{2\pi} \right)^2 \frac{4\pi\epsilon_0}{e^2}$

For n=1, $r_1 = \frac{h^2 \epsilon_0}{\pi m e^2} = 0.53 \times 10^{-10} m$

This is called Bhor radius (a_0)

ie. $a_0 = 0.53 \text{ \AA}$

Note : For hydrogen like atom (Having one electron and atomic number $Z > 1$)

$$r_n = \frac{n^2 h^2 \epsilon_0}{\pi m Z e^2} = \frac{n^2 a_0}{z}$$

- Speed of electron in n^{th} orbit (V_n) - Hydrogen atom.

For hydrogen atom $\frac{mv^2}{r} = \frac{1}{4\pi\epsilon_0} \frac{e^2}{r^2}$

$$\therefore V = \frac{e}{\sqrt{4\pi\epsilon_0 m r}}$$

For n^{th} orbit $V_n = \frac{e}{\sqrt{4\pi\epsilon_0 m r_n}} \dots\dots\dots(1)$

But $mV_n r_n = \frac{nh}{2\pi} \dots\dots\dots(2)$

Eqn (1) becomes $V_n = \frac{e}{\sqrt{4\pi\epsilon_0 m \frac{nh}{2\pi m V_n}}}$ ie, $V_n = \frac{1}{n} \frac{e^2}{4\pi\epsilon_0} \frac{1}{(\frac{h}{2\pi})}$

Rearranging $V_n = \frac{e^2}{2\epsilon_0 n h}$

For first Bhor orbit (n=1) $V_1 = \frac{e^2}{2\epsilon_0 h} = 2.19 \times 10^6 m/s = \frac{c}{137}$

Where C - Velocity of light

$$\therefore V = \frac{1}{n} \frac{C}{137}$$

For hydrogen like atom ($z > 1$), $V_n = \frac{Z e^2}{2\epsilon_0 n h} = \frac{z}{n} \frac{C}{137}$

- Energy of electron is n^{th} state (Hydrogen atom)

PE of electron = $\frac{-1}{4\pi\epsilon_0} \frac{e^2}{r_n}$

$$\text{KE of electron} = \frac{1}{2} \frac{e^2}{4\pi\epsilon_0 r_n} = \frac{e^2}{8\pi\epsilon_0 r_n}$$

$$\therefore \text{Total energy } E_n = \frac{-e^2}{4\pi\epsilon_0 r_n} + \frac{e^2}{8\pi\epsilon_0 r_n}$$

$$\text{ie } E_n = \frac{-e^2}{8\pi\epsilon_0 r_n}$$

$$r_n = \frac{n^2 h^2 \epsilon_0}{\pi m e^2}$$

$$\therefore E_n = \frac{-e^2}{8\pi\epsilon_0 \frac{n^2 h^2 \epsilon_0}{\pi m e^2}}$$

$$\text{ie } E_n = \frac{-m e^4}{8 n^2 \epsilon_0^2 h^2} \text{ or } E_n = - \left(\frac{e^2}{8\pi\epsilon_0} \right) \left(\frac{e^2}{4\pi\epsilon_0} \right) \left(\frac{m}{n} \right) \left(\frac{2\pi}{h} \right)^2$$

Substituting the values

$$E_n = \frac{-2.18 \times 10^{-18}}{n^2} \text{ J}$$

$$\text{or } E_n = \frac{-13.6}{n^2} \text{ eV}$$

$$(1.6 \times 10^{-19} \text{ J} = \text{eV})$$

The -ve sign of the total energy of an e⁻ moving in an orbit means that the electron is bound with the nucleus. Energy will be required to remove the electron from the hydrogen atom to distance infinitely far away from its nucleus

Note:- For Hydrogen like atom

$$E_n = \frac{-13.6 z^2}{n^2} \text{ eV}$$

Explain the formation of line spectra of Hydrogen atom

According to the third postulate of Bohr's model when an atom makes a transition from higher energy state quantum number n_i to the lower energy state with quantum number n_f ($n_f < n_i$) the difference of energy is carried away by a photon of frequency ν if such that,

$$h\nu_{if} = E_{n_i} - E_{n_f} \dots \dots \dots (1)$$

$$\text{But } E_{n_i} = \frac{-m e^4}{8 \epsilon_0^2 h^2 n_i^2}$$

$$E_{n_f} = \frac{-m e^4}{8 \epsilon_0^2 h^2 n_f^2}$$

\therefore Eqn 1 \Rightarrow

$$h\nu_{if} = \frac{m e^4}{8 \epsilon_0^2 h^2} \left(\frac{1}{n_f^2} - \frac{1}{n_i^2} \right) \dots \dots \dots (1)$$

$$\text{or } \nu_{if} = \frac{m e^4}{8 \epsilon_0^2 h^3} \left(\frac{1}{n_f^2} - \frac{1}{n_i^2} \right) \dots \dots \dots (2)$$

This equation is called Rydber's formula for the spectrum of hydrogen atom.
Eqn can be written as

$$\frac{c}{\lambda} = \frac{me^4}{8\epsilon_0^2 h^3} \left(\frac{1}{n_f^2} - \frac{1}{n_i^2} \right)$$

(since $\nu = \frac{c}{\lambda}$)

$$\therefore \frac{1}{\lambda \nu} = \frac{me^4}{8\epsilon_0^2 h^3 c} \left(\frac{1}{n_f^2} - \frac{1}{n_i^2} \right)$$

Here $\frac{me^4}{8\epsilon_0^2 h^3 c} = R = 1.097 \times 10^7 \text{ m}^{-1}$ is called Rydberg const.

$$\therefore \frac{1}{\lambda \nu} = R \left(\frac{1}{n_f^2} - \frac{1}{n_i^2} \right) \dots \dots \dots 3$$

Spectral lines of Hydrogen atom

a. Lyman Series

For this series $n_f = 1, n_i = 2, 3, 4, \dots \dots \dots \alpha$

$$\therefore \frac{1}{\lambda} = R \left(\frac{1}{1} - \frac{1}{n_i^2} \right)$$

This series is in uv region

The series limits of Lyman series given by

$$\frac{1}{\lambda} = R \left(\frac{1}{1} - \frac{1}{\alpha} \right) \quad \mu, \lambda = \frac{1}{R} \text{ (Lowest wave length or highest frequency)}$$

The first member of this series is given by

$$\frac{1}{\lambda} = R \left(\frac{1}{1} - \frac{1}{2^2} \right)$$

$$\lambda = \frac{4}{3R} \text{ (lowest frequency)}$$

b. Balmer Series

For this series $n_f = 2, n_i = 3, 4, 5, \dots \dots \dots \alpha$

$$\frac{1}{\lambda} = R \left(\frac{1}{2^2} - \frac{1}{n_i^2} \right)$$

This is in visible part

Series limit is given by

$$\frac{1}{\lambda} = R \left(\frac{1}{4} - \frac{1}{\alpha} \right) \quad \therefore \lambda = \frac{4}{R}$$

First member $\frac{1}{\lambda} = R \left(\frac{1}{2^2} - \frac{1}{3^2} \right) \quad \mu, \lambda = \frac{36}{5R}$

NUCLEI

- **Composition of Nucleus**

The Nucleus of an atom contains Protons and Neutrons. Protons are positively charged and Neutrons are chargeless. To bind a nucleus together there must be a strong attractive force, enough to overcome the coulomb's force of repulsion between the protons. This strong short range force which binds the nucleons (Protons & Neutrons) together is called Nuclear force.

The following terms and symbols are used to describe a nucleus.

Z = Atomic Number (Number of Protons)

N = Number of neutrons

A = Z+N, mass number (Total no. of Nucleons - protons and Neutrons)

- **Atomic Mass**

Major part of an atomic mass is concentrated in the nucleus. Atomic mass is expressed in atomic mass unit (amu or u)

$$1u = \frac{1^{th}}{12} \text{ mass of } C^{12} \text{ atom}$$

$$1u = 1.6605 \times 10^{-27} \text{ kg}$$

- **Size of Nucleus**

Assuming nucleus to be a sphere of radius R, its volume $\frac{4}{3}\pi R^3$ is found to be proportional to mass number A

$$\text{ie, } \frac{4}{3}\pi R^3 \propto A \quad \text{OR} \quad R \propto A^{1/3} \quad \text{OR} \quad R = R_0 A^{1/3}$$

$$\text{Where } R_0 = 1.2 \times 10^{-15} \text{ m}$$

Density of nucleus is very large and independent mass number A

$$\text{Nuclear density } \rho = \frac{\text{mass}}{\text{Volume}} = \frac{A \times 1.66 \times 10^{-27}}{\frac{4}{3}\pi R_0^3 A}$$

$$= \frac{1.66 \times 10^{-27}}{\frac{4}{3}\pi (1.2 \times 10^{-15})^3}$$

$$= 2.4 \times 10^{17} \text{ g / m}^3$$

Nuclear radius of ${}^{27}\text{Al}$ is $3.9 \times 10^{-15} \text{ m}$. Find nuclear radius of ${}^{216}\text{X}$

$$R_{Al} = R_0 (27)^{1/3}$$

$$R_x = R_0 (216)^{1/3}$$

$$\frac{R_x}{R_{Al}} = \left(\frac{216}{27}\right)^{1/3} = 3.9 \times 10^{-15} \left(\frac{216}{27}\right)^{1/3} = 7.8 \times 10^{-15} \text{ m}$$

- What was the mass defect and Binding Energy
The difference between total mass of nucleons (ie, protons and Neutrons) and the mass of nucleus is called mass defect.

$$\text{ie, mass defect } \Delta m = Zm_p + (A - Z)m_n - M$$

Where Z - Atomic number

A - Mass number

M_p - Mass of proton (1.0073u)

M_n - Mass of neutron (1.0087 u)

M - Mass of Nucleus

The energy equivalent of mass defect is called binding energy

$$BE = \Delta mc^2$$

$$= (Zm_p + (A-Z)m_n - M) C^2$$

$$\text{Note : For mass defect of 1u, } BE = \frac{1 \times 1.66 \times 10^{-27} \times (3 \times 10^8)^2}{1.6 \times 10^{-13}} \text{ meV} = 931 \text{ meV}$$

Note : BE is the energy needed to separate the nucleons apart

- Binding energy per nucleon = $\frac{BE}{A} = \frac{\Delta mc^2}{A}$

$$= \frac{(Zm_p + (A - Z)m_n - M) C^2}{A}$$
- Discuss the variation of Binding energy per nucleon with mass number.
 - The Binding energy per nucleon is practically independent for nuclei of middle mass number ($30 < A < 170$). The curve has maximum about 8.75 meV for $A = 56$ (${}_{26}\text{Fe}^{56}$) and has a value 7.6 meV for $A = 238$ (${}_{92}\text{U}^{238}$)
 - Binding energy per nucleon is lower for both light nuclei ($A < 30$) and heavy nuclei ($A > 170$)

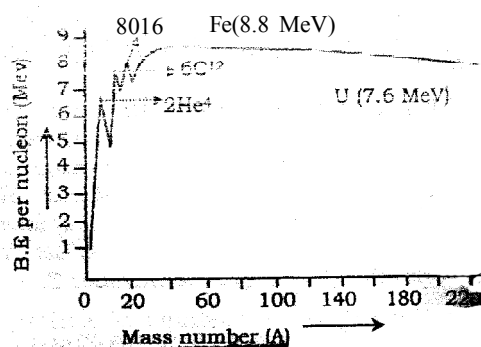

Radioactivity

It is the phenomenon by which an unstable nucleus ($A > 206$) decays by emitting particles such as α , β , γ in order to achieve stability. This was discovered by Hency Becquerd in 1896.

- Activity
Activity of radioactive sample is the rate of decay of the nucleus.

$$\text{Activity } A = \frac{dN}{dt}$$

Where N is the number radioactive nuclei in a sample.

- SI unit of Activity is Becquerd (Bq)
1 Bq = 1 disintegration/second

1 curie = 1 Ci = 3.7×10^{10} Bq
 1 Rutherford = 1 Rd = 10^6 Bq

- **Radioactive Decay law**

This law states that rate of disintegration is directly proportional to total number of nuclei in that sample.

If N is the number of nuclei present in a sample at a time 't'

$$\frac{dN}{dt} \propto N$$

or $\frac{dN}{dt} = -\lambda N$ Where λ is called decay const. or disintegration const.

or $\frac{dN}{dt} = -\lambda dt$

Integrating $\int_{N_0}^N \frac{dN}{N} = -\int_0^t \lambda dt$

$\log N - \log N_0 = -\lambda t$

Where N_0 is the initial number of nuclei present in the sample (at $t=0$)

or $\log \left(\frac{N}{N_0} \right) = -\lambda t$

$N(t) = N_0 e^{-\lambda t}$

This eqn. gives the number of radioactive nuclei present in the sample after a given time 't'. If N_0 is the number of nuclei at $t=0$

- **Half life :** It is the time taken by the radioactive sample to decay to half the initial number.

(ie, N becomes $\frac{N_0}{2}$)

\therefore When $t = T_{1/2}$

$N_{(t)} = \frac{N_0}{2}$

$N_{(t)} = N_0 e^{-\lambda t}$

$\frac{N_0}{2} = N_0 e^{-\lambda T_{1/2}}$

$\frac{1}{2} = e^{-\lambda T_{1/2}}$

$e^{-\lambda T_{1/2}} = 2$

$\lambda T_{1/2} = \log 2$

$T_{1/2} = \frac{\log 2}{\lambda} = \frac{0.693}{\lambda}$

ie, $T_{1/2} = \frac{0.693}{\lambda}$ or $T_{1/2} = \tau \cdot 0.693$

Where $\tau = \frac{1}{\lambda}$ is called mean life of the sample.

- **α - decay**

In α - decay the mass number of daughter nucleus is four less than parent nucleus, While atomic number decreases by 2.

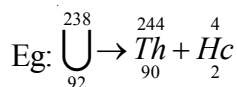
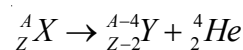

Energy released during α decay

$Q = [m_x - (m_y + m_\alpha)] C^2$

- **β^- - decay**

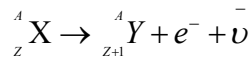

e^- - Beta minus, $\bar{\nu}$ - antineutrino

(Here a neutron in the nucleus decays to proton, electron and antineutrino. This electron is emitted as β^- and the proton increases the atomic number by one)

For β^+ plus decay, a proton transform into,

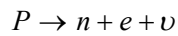

Here e^+ is emitted as β^+ plus and atomic number decreased by one.

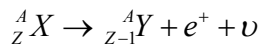

ν - neutrino $e^+ \rightarrow \beta^+$ plus

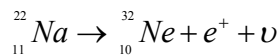
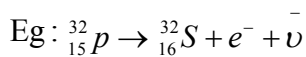

Note : -ve electron - negatron
+ve electron - positron
They are collectively called positronium

γ - Decay

When a nucleus in a excited state (Daughter nucleus formed after the α or β decay) spontaneously decays to ground state, a photon is emitted with energy equal to the difference in the two energy levels of the nucleus. This decay is called γ - decay.

Nuclear Fission

It is the process by which a heavy nucleus splits into two or more light nuclei.

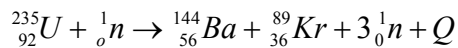

The self sustained nuclear fission process is called chain reaction. In a nuclear Reactor chain reaction takes place in a controlled manner.

Only slow neutrons can induce fission in a fissionable material so the slowing down of fast neutrons liberated in the initial fission process will sustain the chain reaction.

In a nuclear reactor this process is achieved by neutron moderators (Eg: Heavy water, graphite) These moderators should not absorb neutrons, they should only reduce the speed of neutrons.

In a nuclear reactor to control the chain reaction by absorbing extra neutrons, control rods are used (Eg: Calcium, Boron, Cadmium)

Nuclear Fusion

It is the process by which two or more light nucleus combine to form a heavy nucleus with the release of energy. It is the source of energy in stars. The energy released during fusion is called Thermonuclear energy. Fusion process need extremely high temperature to initiate the process.

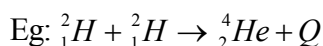

Chapter 12

SEMICONDUCTOR ELECTRONICS

1. Classification of metals, conductors and semiconductors

	Metals	Semiconductors	Insulators
Resistivity ρ	10^{-2} to $10^{-8} \Omega \text{ m}$	10^{-5} to $10^6 \Omega \text{ m}$	10^{11} - $10^{19} \Omega \text{ m}$
Conductivity σ	10^2 to 10^8 S m^{-1}	10^5 to 10^{-6} S m^{-1}	10^{-11} to $10^{-19} \text{ S m}^{-1}$

Semiconductors

- a. Elemental semiconductors like Si, Ge
 - b. Compound semiconductors
 - i. Inorganic - Cds, Ga As, Cdse, InP etc,
 - ii. Organic - antheracene, doped pthalocyanines
 - iii. Organic polymers - polypyrrole, polyaniline, polythiophene etc.
- The currently available semiconducting devices are mainly elemental semiconductors and compound inorganic semiconductors.

Energy band

The energy level of an atom inside a crystal is different from isolated atoms due to the interaction between the neighbouring atoms.

Inside the crystal each (electron) has a unique position and there exist no two e^- with exactly the same pattern of surrounding charges. Therefore each e^- will have a different energy levels. These energy levels with continuous energy variations are called energy bands.

Note : Range of energy possessed by e^- in valence shell within the atom in a crystal is called valence Band and range of energy possessed by free e^- is called conduction band. At absolute zero (no external energy) all valence electrons will reside in the V.B. The gap between lowest level of conduction band and highest level of V.B is called forbidden energy gap.

Classification of Substances in terms of Energy band

In some metallic conductors, the lowest level of C.B is lower than the V.B. Then the e^- from V.B can easily move into C.B, where normally C.B is empty. Due to overlapping of VB and CB, free e^- are available for conduction

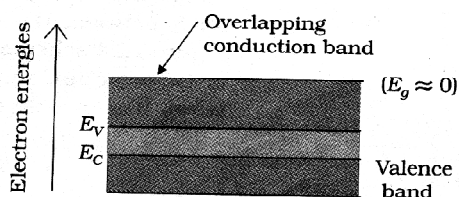

In some metals there is a gap b/n the lowest level of conduction band and highest level of VB. In such metals V.B and C.B are partially filled. Presence of e^- in C.B enables large conductivity. When the valence band is partially empty, e^- from its lower level moves to higher level making conduction possible.

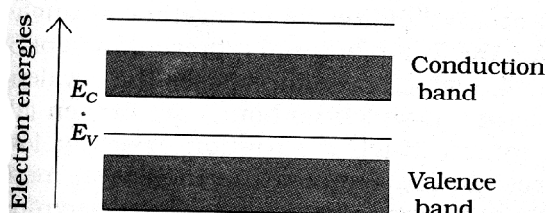

In Semiconductors : the highest level of V.B and lowest level of C.B are separated with a small energy gap (say $<3\text{eV}$). At absolute zero, the V.B is completely filled and C.B is completely empty and it behaves as an insulator. At room temp, some e^- from V.B can acquire enough energy to cross the energy gap and enter the conduction Band. Hence the resistivity of semiconductor decreases with increase in temp.

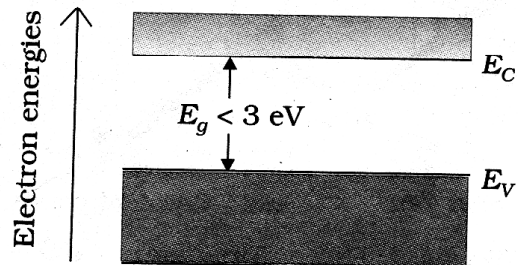

In the case of insulators, the energy gap b/n the V.B and C.B is $>3\text{eV}$. There are no e^- in the conduction band and no electrical conduction is possible. It is noted that the energy gap is so large that e^- cannot be excited from V.B to C.B by thermal excitation. Hence the resistance is very high and conductivity is very small.

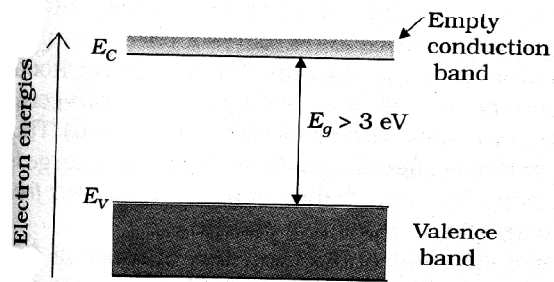

Intrinsic semi conductor

Pure elemental semi - conductors are called intrinsic semi conductor. Si and Ge are intrinsic semi conductors. In each Si and Ge atom, there are four valence e^- . In its crystalline structure, every Si or Ge share one of its 4 valence e^- with each of its four nearest neighbour atoms and form covalent bond as shown in the figure. At absolute zero, all bonds are completed and no bonds are broken.

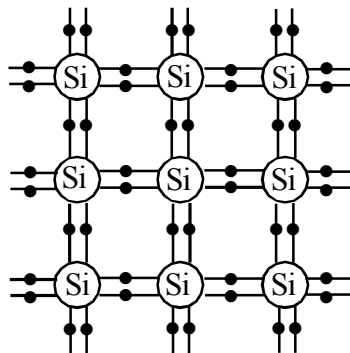

As the temp increases more internal energy becomes available to these e's and some of these e's may break the bond and become free e's. The thermal energy creates a vacancy in bond called holes. The hole behaves as an apparent free particle of charge +e. The thermal energy ionise the si atom and free an e

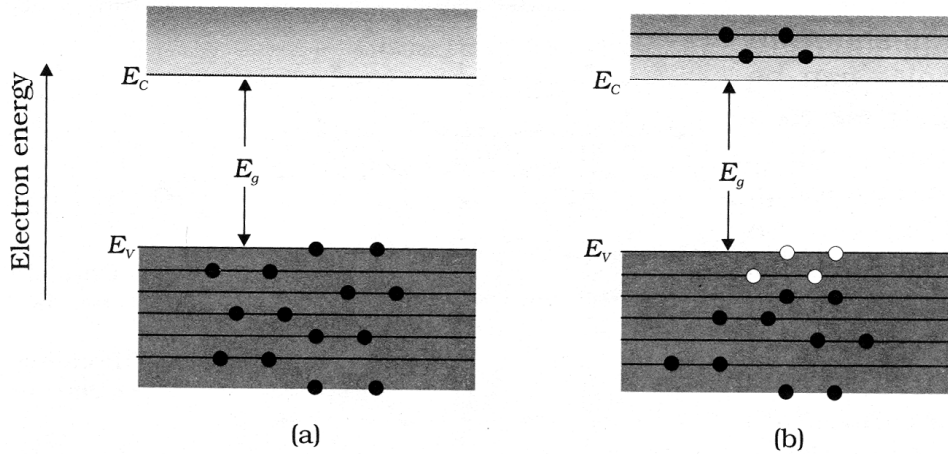

The conductivity of Si increases with temp. In a semiconductor conductivity is due to free e's in the conducting band and holes in the V.B. In intrinsic semiconductor no. of e's in C.B is equal to no. of holes in the V.B which is equal to intrinsic carrying conductor $n_e = n_h = n_i$ the equilibrium no. of holes created is equal to no of holes the carrier concentration of e constant at equilibrium

$$\text{The total current } I = I_e + I_h$$

Note

At 0K an intrinsic semiconductor behaves like an insulator $T > 0K$, it behaves like better conductor.

- Q1. C, Si, Ge have same lattice structure. Why is C insulator while S and Ge are instrinsic semiconductor?
 Q2. Identify the material, by using energy band diagram at $T > 0K$

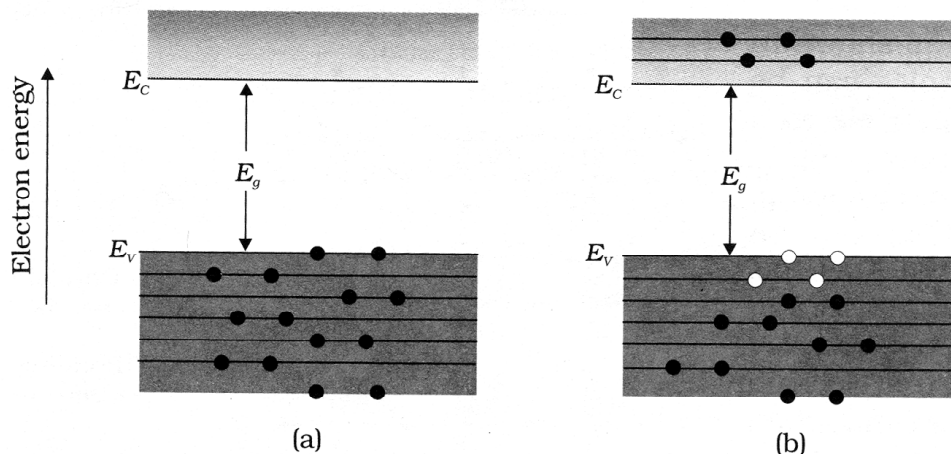

Extrinsic semiconductor

The conductivity of the pure semiconductor is increased by adding suitable impurity atoms. The impure semiconductor is called extrinsic semiconductor.

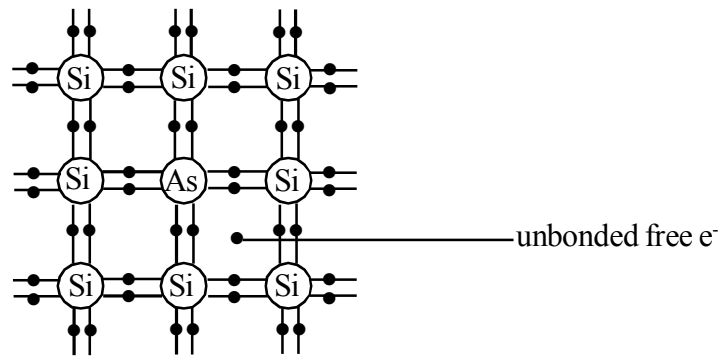

Doping

The deliberate addition of a desirable impurity atom into a pure semiconductor is called doping and material used for doping is called dopant. The dopant has to be added such that it does not distort the original pure semiconductor crystal. Therefore the size of the dopant and semiconductor atoms should be nearly the same size.

Q. Why the dopant elements are pentavalent or trivalent?

The pure semiconductor Si and Ge belongs to group 14 in the periodic table and therefore we choose the dopant element from 15th and 13th group for taking care that size of the dopant atom is nearly the same size as Si or Ge.

n type semiconductor

The pure semiconductor Si or Ge is doped with pentavalent impurity like Arsenic (As), Antimony (Sb), Phosphorus (P), etc. the crystal obtained is called n-type semiconductor.

When an atom of pentavalent element is added to pure semiconductor, Si crystal, the pentavalent (As) impurity occupies the position of an atom in the crystal lattice of Si. Four of its electrons bond with the four Si atoms while the 5th e^- remains very weakly bound to its parent atom As. As a result the ionization energy required to set these electrons free is very small and even at room temp. it will be free to move in the lattice of semiconductor.

By using energy band diagrams, we can explain the conductivity of n-type semiconductor. The energy level of As atom is 0.05 eV below the CB energy level of Si atom. Therefore the free electron of the pentavalent atoms easily occupies the CB.

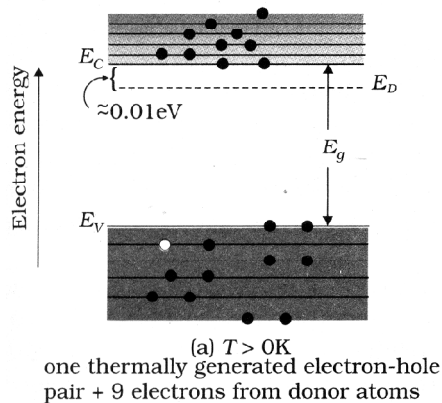

Pentavalent is donating an electron to the crystal lattice. Therefore, pentavalent impurity is called donor impurity. The no. of free e's, in the C.B. is depends on the doping concentration.

In a doped semiconductor no. of holes (n_h) is depends on temp. while no. of e's (n_e) is due to contribution of donors and thermally generated e's in the pure semiconductor. Thus with proper level of doping $n_e \gg n_h$. Hence in an extrinsic semiconductor, doped with pentavalent impurity, e's becomes the majority carriers and holes are the minority carriers. Therefore, the semiconductors are called 'n' semiconductor.

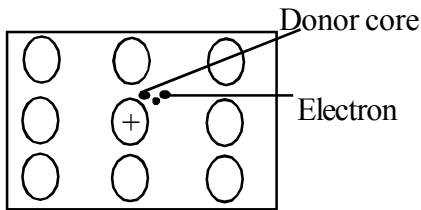

In n type semiconductor the donor is charged +vely by donating e⁻ to the crystal.

P type semiconductor

P type semiconductor is obtained when si or Ge is doped with trivalent impurities like Al, B, In, etc.

Due to deficiency of electrons in the bond after sharing 3 e's with neighbouring si atoms, hole is created in the bond. This vacancy is filled by accepting an e⁻ from crystal lattice it in turn creates a hole in the V,B of Si Now, the trivalent atom atom become negatively charged by accepting e⁻ from si atom. In p type semiconductor trivalent atom is called as acceptor because it accepts the e⁻ from the pure semiconductor crystal and ionise - vely.]

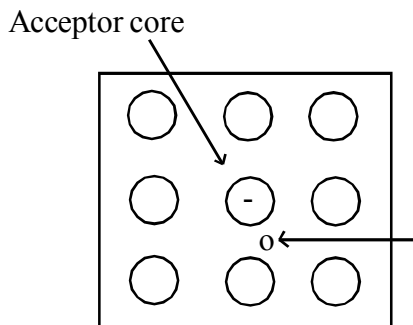

In p type semiconductors no. of holes are more than the thermally generated electron. Therefore holes are majority carries and e's are the minority carries. In p type semiconductor, the recombined process will further reduce the number of intrinsic carrier concentration.

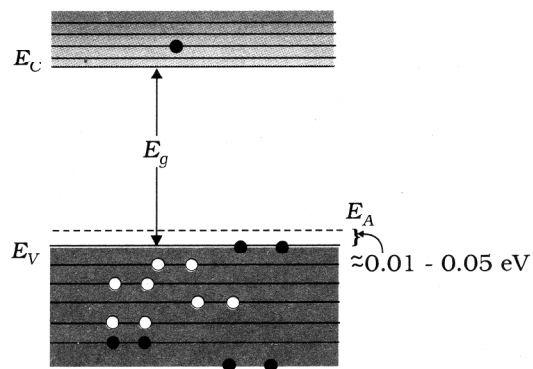
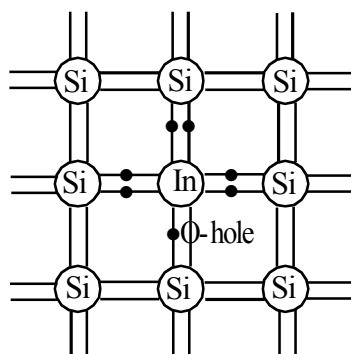

(b) $T > 0K$

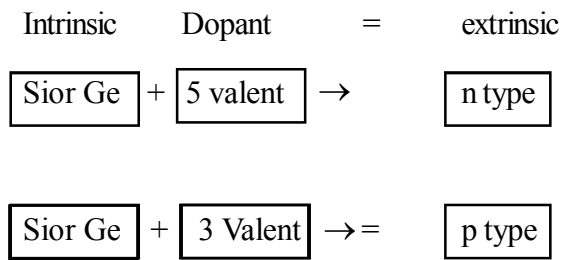

Note :

1. In n type or p type semiconductor is maintained charge neutralites.
2. By adding dopant numbers, which become majority carriers, indirectly helps to reduce the intrinsic concentration of minority carriers.
3. At room temp. in an extrinsic semiconductor at thermal equilibrium is given by $n_e n_h = n_i^2$
4. Pentavalent dopant is donar, Trivalent dopant is acceptor.

Band gap of group IV or XIV

Elements	Band gap	
C	5.4 ev	Insulator
Si	1.1ev	Semi conductor
Ge	0.72 ev	Semiconductor
Sn	0.1ev	Conductor

Q. Suppose a pure Si crystal has 5×10^{28} atom per m^3 . It is doped by 1ppm concentration of pentavalent As. Calculate no of e's and holes (given $n_i = 1.5 \times 10^6 / m^3$)

It is a ntype semiconductor

$$n_e n_h = n_i^2$$

$$n_h = \frac{n_i^2}{n_e} = \frac{(1.5 \times 10^6)^2}{4.5 \times 10^9}$$

$$n_e = 5 \times 10^{22} m^{-3}$$

Note : 1PPm - 1 Part per million

$$n(d) = n_e = 5 \times 10^{28} \times \frac{1}{10^6}$$

$$= 5 \times 10^{22} m^{-3}$$

Q. Intrinsic semiconductor

- a. Si + X → n type semiconductor
- b. Ge + Y → p type semiconductor

Choose X and Y from the following

Cu, Ag, Al, C, Sn, Sb

- c. Explain how to prepare n type semiconductor?
- d. Explain how to prepare p type semi conductor?

How to form a pn junction

Take a thin p type si semiconductor wafer by adding controlled amount of pentavalent impurity. Now, part of p type si wafer can be converted into n type si. The wafer contains p region and n region and a interface of p and n called pn junction as shown in fig.

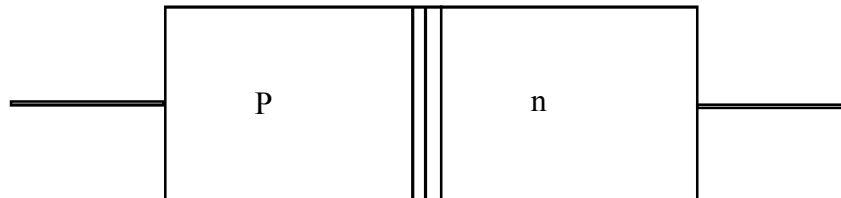

Explain important process occur during the formation of a pn junction

Diffusion

We know that in n type semi conductors, electron concentration is more compare to the concentration of holes. Similarly in a p type semiconductor, the concentration of holes is more than es. During the formation of p-n junction, and due to the concentraiton gradient, holes are diffuse from p side to n and electrons diffuse from n side to p side. This motion of charge carriers gives diffusion current.

Explain depletion region.

When an electron diffuses from n to p side due to the concentration gradient, it leaves an ionized donar on n side. Similarly when a hole diffuses from p to n side it leaves an ionized acceptor on p side. This iones are immobile due to continuous diffusion of electrons and holes a layer of negative space charge region on p side and +ve space charge region on a n side of the pn junction. This region is called depletion region

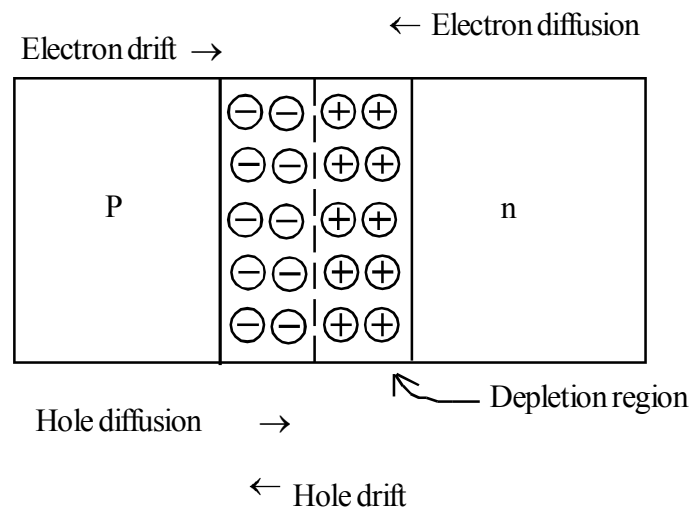

Drift

Due to the +ve space charge region on n side of the junction, and -ve charge on p side of the junction, an electric field directed from n side to p side of the junction. Due to this field the minority carriers, ie, electrons from p side moves to n side and holes move n side to p side. The motion of minority carriers due to electric field is called drift.

Note

1. Diffusion of majority carriers gives diffusion current and drift of minority carriers gives drift current. Diffusion current and drift current are opposite in directions.
2. Initially, diffusion current is large and drift current is small, As the diffusion process continuous the space charge region either side of the junction extend thus increases the electric field strength and hence drift current. This process continuous untill the diffusion current equals the drift current. Thus a pn junction is formed. In a pn junction under equilibrium there is no net current.

Explain Barrier potential

Due to diffusion, the loss of e's from n region & gain of e's to the p region causes a difference of potential across the junctions of the 2 regions. Thus potential creates an electricfield which opposes further flow of carriers. So that the equilibrium is reached. At equilibrium a constant potential difference exists across the junction. This potential difference is called barrier potential.

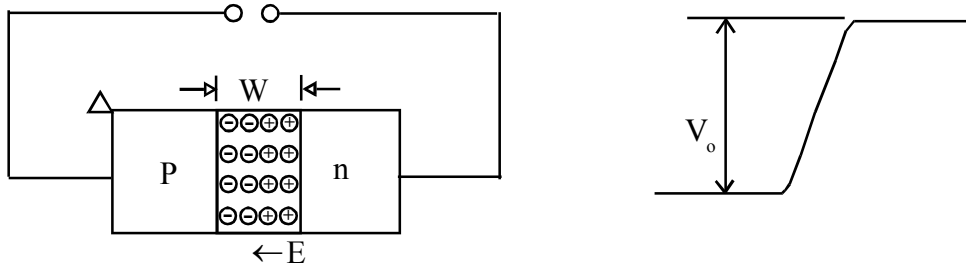

Explain the action of P- n junction diode under Forward bias? When an external voltage V is applied across a diode such that P is to +ve and n is to -ve, the biasing is called forward biasing.

The external applied voltage (v) is opposite to that of barrier potential (V_0) As a result the width of depletion region decreases and the barrier height is reduced. The barrier height under forward bias condition is ($V_0 - V$)

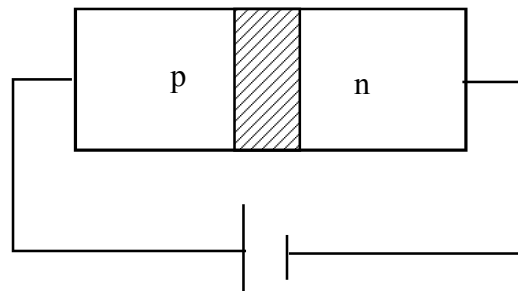

If $V < V_0$, the barrier potential will be reduced slightly and only a small number of carrier will possess enough energy to cross the junction. So the current will be small. If we increase the

applied voltage ($V > V_0$) the barrier height will be reduced further and more number of carriers will have the sufficient energy. Thus current increases.

In the forward biased condition, the minority carrier injection towards P side and towards n side takes place. Due to applied voltage, electrons from n side cross the depletion region and reach p side. Similarly holes from p side to n side at the junction boundary on each side, the minority carrier concentration increases. This injected minority carrier diffuses toward edges of the crystal and constitute of the current. Total current is the sum of hole diffusion current and electron diffusion current.

$$I = I_e + I_n$$

Note :

At room temperature the barrier potential are ① 0.2v to 0.3v for Ge

② 0.5v to 0.7v for si

Q. Can we take on slab of P type semiconductor and physically join it to another n type semiconductor to get P - n junction?

No. An slab, how ever flat, will have roughness, much larger than inter atomic crystal spacing hence continuous contact at atomic level will not be possible. The junction will behave as a discontinuity for the flowing charges carriers.

Q. Why the resistance of depletion region is higher than other part of the P.n junction?

Depletion region is the region in which no free charge carrier . While other part of the P and n semiconductor have free charge carrier.

Q. What is P-n junction diode and draw its circuit symbol? Semi conduction diode is a Pn junction with 2 external terminal for external voltage supply. It is a...

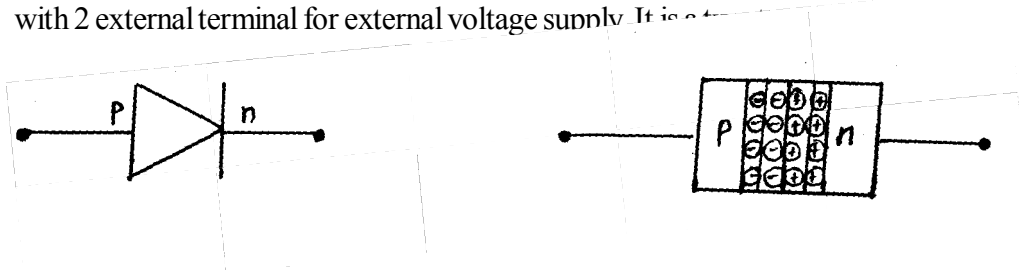

Forward bias and P-n junction diode

The P side of the diode is connected to positive of the external voltage source and n side is connected to the negative of the voltage source as shown in Figure. a

Note : P side connected to high potential and n side connected to lower potential is also forward biased forward biased pn junction as shown fig (b)

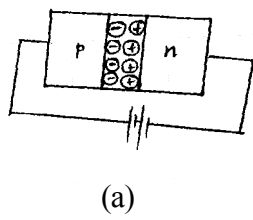

OR

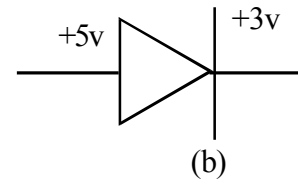
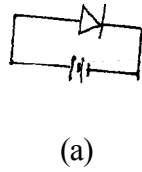

Q Explain Pn junction diodes under reverse bias?

When reverse potential (V) is applied to the diode the sense of direction of applied voltage and barrier potential are same. As a result, barrier potential and width of depletion region increases. The effective barrier height is $(V+V_0)$. Then electric field at the junction is not favourable for majority carrier holes from P to n and electron from n to P. Thus diffusion current decreases enormously compared to the diode forward biased conduction.

The electric field at reverse condition is favourable for minority carrier to cross the junction i.e., electrons from P to n and holes from n to P. This give rise the drift current of order of microamphere.

Q. How to reverse bias P - n junction

When an external voltage (v) is applied across the diode such that n side is +ve and P side is -ve. It is said to be reverse biased.

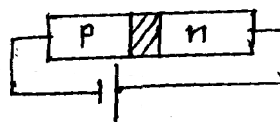
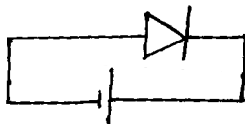

Q. Is the reverse current or drift current depends on applied voltage why?

No because a small reverse enough to sweep the minority carrier from one side of the junction to the other side. This current not controlled by the magnitude of the applied voltage but it limited due to the minority carrier concentration.

Q. What is breakdown Voltage?

The current through the diode under reverse bias is essentially voltage independent upto critical reverse voltage (V_{br}) when applied voltage is equal to V_{br} , the diode reverse current increases sharply. Even a slight increase in the bias voltage causes large change in the current. This voltage is called break down voltage.

Q. What happens to the diode. If we operate the diode in reverse biased condition equal or greater than V_{br} ?

The diode gets destroyed due to over heating, for safety operation of the reverse diode applied should be below the specified rated value of the manufacturer.

Q. How to explain the breakdown?

At higher applied voltages the breakdown is believed to be caused by avalanche of charge. The electrons of reverse. Saturated current are accelerated to high velocities by the electric field across the depletion region. At some critical field these charges acquire sufficient velocity to break valence bonds upon collision with the atoms of the semiconductor. This process generate more e^- - hole pair and current builds up in large amount.

Q. Draw the circuit diagram to study the forward characteristics.

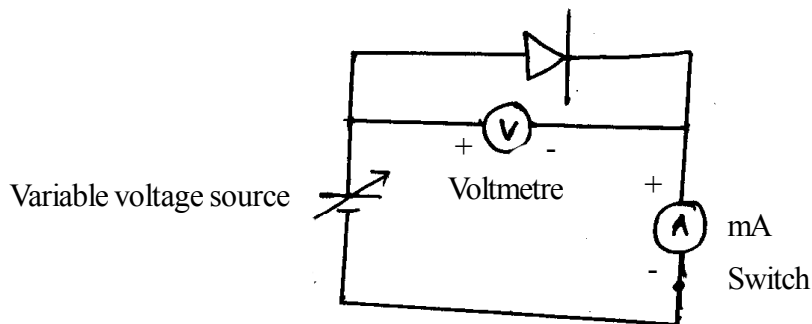

The circuit arrangement to study the forward characteristic as shown in figure.

The forward voltage is gradually increases from zero corresponding current is noted in milliammetre. The graph between V and I is obtained. It is noted that the current initially increases very slowly almost negligible, till the voltage across the diode reaches to a certain value. After this characteristics voltage, the diode current increases exponentially with applied forward voltage. This critical voltage of which the current increases very sharply is called threshold voltage or cut in voltage (0.2 to 0.3 v for Ge and 0.5 to 0.7 v for si)

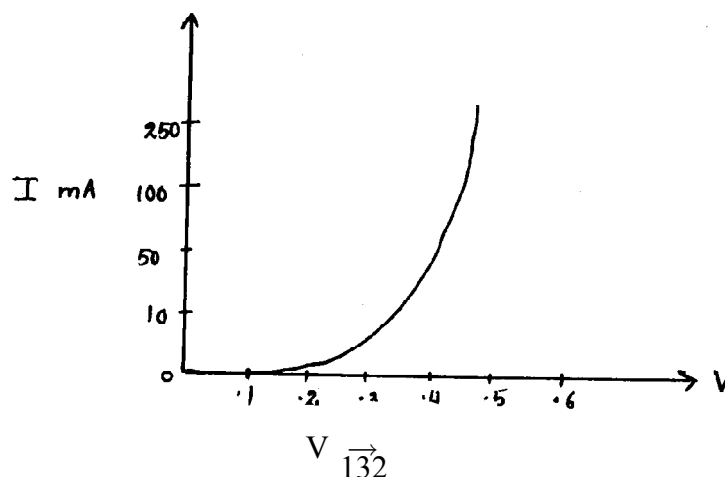

Explain the reverse characteristic of a diode

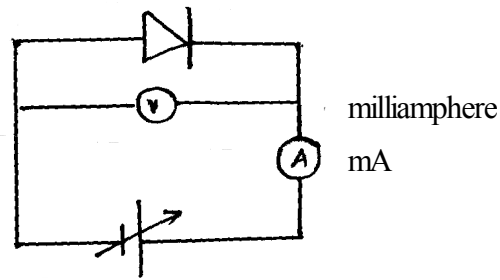

The circuit diagram to study the reverse characteristics as shown in the figure.

The reverse voltage is increase from zero. The reverse current is small of the order of micro ampere and almost remains constant with change in bias voltage. The current is called reverse saturation current. At high reverse voltage (V_{br}) the current increases suddenly. In general purpose diode are not used beyond the break down voltage.

Q. Explain unidirectional conducting property of diode?

The forward biased resistance of the diode is low as compared to the reverse bias resistance. The diode conduct only when its forward biased and it is not conducting when its reverse biased. This property of the diode is called unidirectional conducting property.

Q. Which property of the diode is used Rectifier?

Unidirectional conducting property.

Q. What is a rectifier?

It is the device used to convert high voltage AC in to low voltage pulsating DC

Q. Explain how a diode act as a rectifier?

The unidirectional conducting property of the diode is used for rectification. It means diode allows current only when it is forward biased. An alternating voltage is applied across the diode the current flows only in that of cycle when the diode is forward biased.

Explain half wave rectifier with circuit diagram?

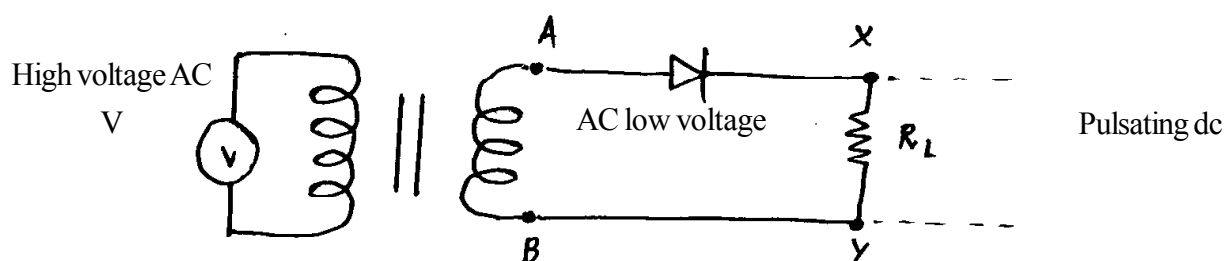

If an alternating voltage is applied across the diode in series with a load, a pulsating voltage will appear across the load only during the half cycle of the input ac during which the diode is forward biased. This type of rectifier is called half wave rectifier.

The secondary of a transformer supplies the desired ac voltage across terminals A and B. When voltage at A is +ve, the diode is forward biased and it conducts. When A is negative, the diode is reverse biased and it does not conduct.

Therefore, in the +ve half cycle of ac there is a current through the load resistor R_L and we get an output voltage. Whereas no current in the negative half cycle. This process is repeated and we get output when the diode is forward biased. Thus, the output voltage, though still varying is restricted to only one direction and is said to be rectified. Since the rectified output of this circuit is only for half of the input ac wave it is called the half wave rectifier.

- Q. An input ac voltage of frequency 50Hz is given to half wave rectifier.
- Show the output wave form
 - What is the frequency of pulsating dc.

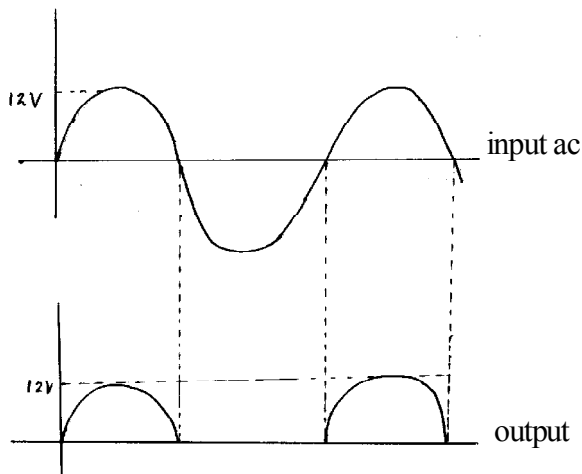

- 50 Hz, Frequency, remains same.
- Q. A boy like design a half wave rectifier with pulsating dc of max 9v
- Give the circuit diagram with essential components?
 - What he has to do to get pure dc?

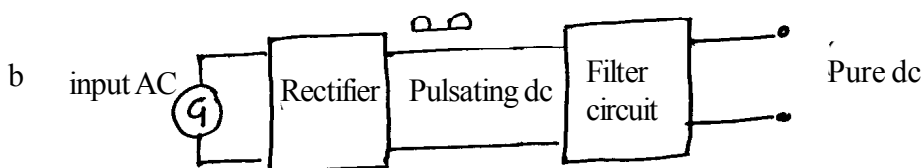
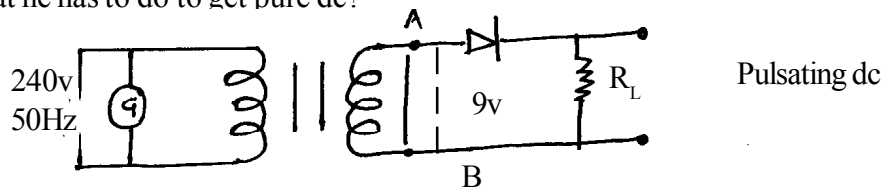

To get a pure dc a filter circuit should be cascaded with a rectifier

Q. Circuit diagram shown in figure is acted as half wave rectifier or not justify your answer?

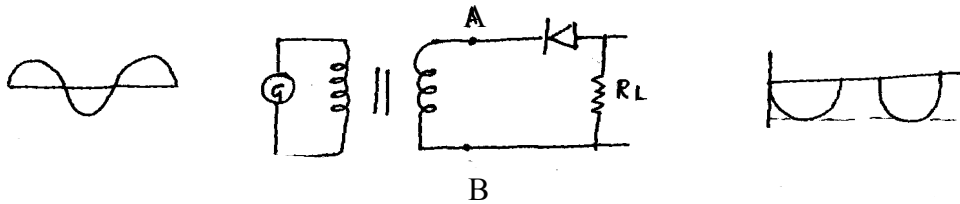

yes. At every negative cycle of input of ac at A, the diode is forward biased and output voltage across R_L . At every positive cycle of input of ac at A, the diode is reverse biased and not conduct.

Q. Explain full wave rectifier?

By using two or more diodes, gives output voltage corresponding to both the positive as well as negative half of a ac input. Hence the rectifier is called full wave rectifier.

Draw circuit diagram and explain the centre tap full wave rectifier.

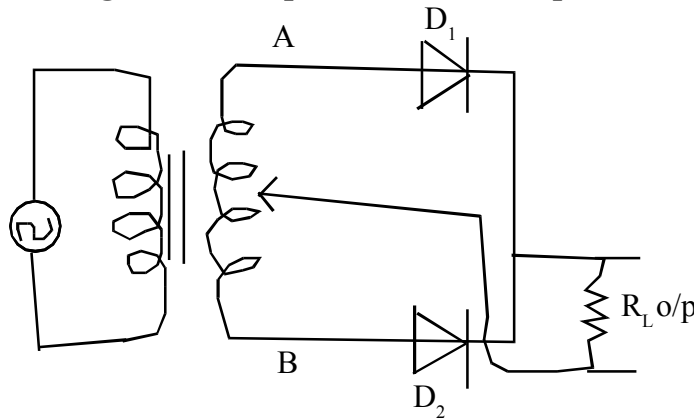

Two diodes D_1 and D_2 are connected to the ends of secondary of the transformer. Then n side of the diodes are connected together and the output is taken b/n the common points of diodes and centre tap of the secondary of the transformer. Here is called central tap full wave rectifier.

In positive half cycle of input ac, A is +ve and B is -ve. The diode D_1 conduct and D_2 does not conduct, there is output across R_L . In negative half cycle of ac, B is +ve and A is -ve D_2 conduct and D_1 does not conduct, there is output across R_L . Here pulsating output is obtained for both input ac cycles. It is more efficient circuit for getting rectified voltage than half wave rectifier.

- Who invented zener diode and Draw its circuit symbol

a. C.Zener

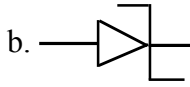

- A junction diode which works only in the reverse break down voltage or zener voltage.
 - Maximum reverse voltage that can be applied without damage
 - Voltage across the diode is constant.
- Give one use of zener diode : It is used as voltage regulator.
 - Explain the zener diode and how it act as voltage regulator.

Zener diode is a heavily doped P-n junction diode. Due to heavily doping, the width of the depletion region is very thin less than micron and electrified at the junction is very high ($E=v/d$) of the order of 5×10^6 v/m for small reverse voltage.

Zener is always operated in reverse biased condition. The applied reverse voltage is equal to break down voltage ($v_1 = V_{br}$) large change in current for a small negligible change of reverse voltage. That is, zener voltage remains constant, even through current through the zener changes, over a wide range. This property of zener is used for regulating the voltages.

Draw circuit diagram of zener diode as voltage regulator

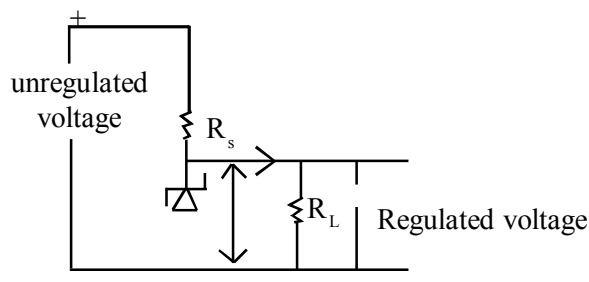

- In case of ordinary diode, the large heating effect produced, destroyed the diode when it is operated more than breakdown voltage, but zener diode is safe when it is operated in reverse biased state. Why?

In the case of ordinary diode in reverse biased condition the width of depletion region is so large and has high resistance of the order of $10^6 \Omega$. The large current passing through the junction due to field emission produces more joule's heating effect. In the case of zener diode, it is heavily doped and hence the depletion region is thin and is less than that of ordinary diodes. Hence total heating effect is less and it is safe in the reverse biased condition.

- What is opto electronic junction devices?

Semi conducting diode in which the carrier are generated by light or photons.

Name different opto electronic devices.

1. Photo diode
2. Light emitting diode (LED)
3. Photo voltaic device (Solar cell)

- Mention uses of photo diode?
 1. It used in optical communication as photo detector
 2. Its used in electronic equipment TV which can operated with remote controller.
- Draw the circuit symbol and circuit diagram of photo diode.

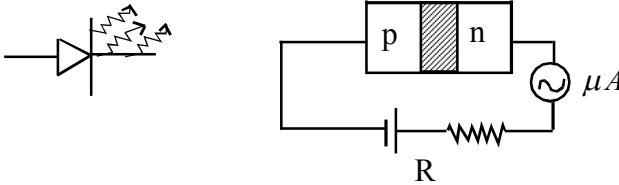

- What LED, Draw its circuit symbol
 It is heavily doped special pn junction diode which is operating forward biased condition. The diode is enclosed in a transparent cover so that emitted light can come out.

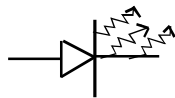

- What are the used of LED?
 - i. It is used as light source.
 - ii. Remote control - (Infrared LED)
 - iii. Burglar alarm
 - iv. Optical communication
- What are the advantages of LED?
 - i. Low operated voltage.
 - ii. Fast action and no warm up time required
 - iii. Band width of light (100A to 500A) therefore it nearly
 - iv. Long life
 - v. Environmental friendly
 - vi. Fast on-off switching actions.
- What are the solar cells? Draw it's circuit symbol?

A solar cell is a Pn junction which generates emf when the solar radiation falls on the pn junction. It is based on principle of photo diode except that no external bias is applied and junction area is kept much larger for solar radiation.

- Write the suitable material for solar cell
 For solar cell the band gap nearly 1.5ev are suitable materials for solar cell.
 1. Si \rightarrow (Eg - 1.1ev)
 2. GaAs \rightarrow (Eg - 1.4ev)
 3. S cd Te \rightarrow (Eg - 1.45ev)
 4. Cu in S_{e2} \rightarrow (Eg - 1.04 ev)

- What are the important criteria for the selection of material for solar cell?
 1. Based gap (Eg 1.0ev to 1.8ev)
 2. High optical absorption
 3. High electrical conductivity
 4. Availability of rawmaterial
 5. Low cost
- Uses
 1. It is used in power electronic devices in satellites and space vehicle.
 2. It is the power supply to save electronic devices such as calculator.
 3. Solar heater
 4. Solar lamps
 5. Solar charger etc.
- Why Si and Ga As are preffered material for solar cell? Why not cds, edSe Reffer NCERT Text Eg: 14.7.
- Who invented point contact transistor which consists of two pn junction connected back to back?

William shottkey in 1951.

- What is BJT (Bipolar Junction Transistor)
This transistor operate with holes and electrons.
- Name two types of bipolar junction transistor.

1. npn : The emmitter and collector n type and are seperated by a thin segment of P- type called base.

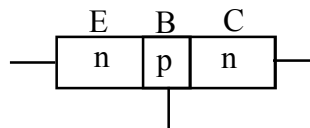

2. The emmitter and collectorare p-type and are seperated by a thin segment of n type called Base.

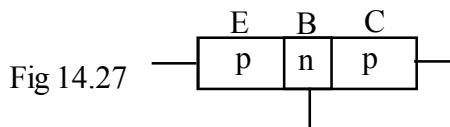

- Explain the 3 segment of a transistor?
 1. **Emmitter** : It is moderate in size and heavily doped. It supplies as large number of majority carriers for current flow through the transistor.
 2. **Base** : It is in between emmitter and collector. It's very thin as lightly doped.
 3. **Collector** : Collects major portion of the majority carriers emmitted by this emmitter, larger in size, moderately doped.

- Show the circuit symbol npn and pnp transistor

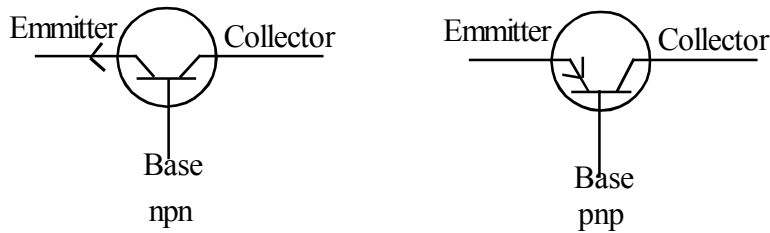

- Name 3 transistor configuration

1. CB (Common Base) Base in common to input and output
2. CE (Common Emitter) Emitter is connected to input and output
3. CC (Common collector) Collectors common to input and output

- Is the transistor a power of generating device? No, power of ac input signal is amplified by the expenses of biasing voltage.

Why CE is generally preferred for amplification

CE configuration have current gain, voltage gain and power gain.

- Differentiate between amplifier and oscillator

In any amplifier, by the aid of external biasing battery strength of the low input signal is amplified and obtained at the output and input is necessary to obtain output. In an oscillator sustained oscillation of ac signal is obtained at the output without the aiding external input signal i.e., input oscillating signal is not necessary to obtain output sustained oscillating.

Oscillator - The process of converting dc signals into ac signals of desired frequency. A device which does this function is oscillator

Alternator (ac dynamo) - Produces ac of frequency up to 1000Hz.

Essential parts of oscillator (i) Tank circuit - LC circuit to produce electrical oscillations (ii) Amplifying circuit (iii) feedback circuit.

- Digital Electronics

What is analogue signal

The signal has been in the form of continuous, time varying voltage or current is called analogue signal.

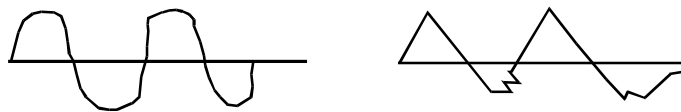

- What is Digital Signal

The voltage or current represented by two levels of voltage or current. Such signal is called digital signal.



Pulse wave form of digital signal

- What is logic gate

Logic gates are the building block of digital electronics. Logic gates are based on some logic operation between the input and output.

Or gate

OR gate has two or more inputs with one output. The output OR gate is 1 for any one of the two input is 1. And output is zero, if both input are zeros.

a) Circuit symbol of OR gate

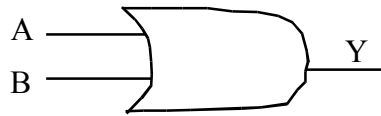

A input	B input	Y=A+B Output
0	0	0
0	1	1
1	0	1
1	1	1

b) Truth table of OR gate

It is the display of input output relation with all possible functions.

c) Timing diagram

Input - output wave forms in called timing diagram

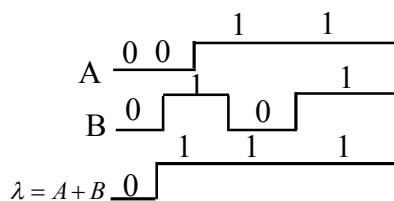

- The output of AND gate is one, if only of both inputs are 1's and zero, if any one of the two input is zero circuit symbol.



• Truth table of AND

A	B	Y=A.B
0	0	0
0	1	0
1	0	0
1	1	1

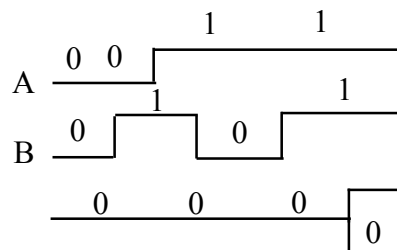

• NOT Gate

This is most basic gatem with one input and only one output it gives 1 output of the inout is 0 and output 0 if input is 1.

Truth table

A	\bar{A}
0	1
1	0

Timing diagram

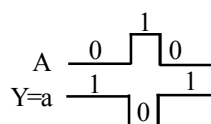

Circuit symbol

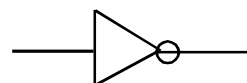

- **NAND**

The output of AND gate is followed by NOT gate

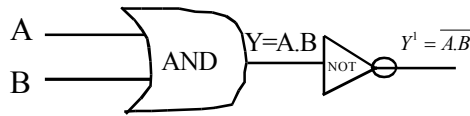

Circuit symbol

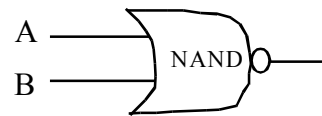

- **Truth table of NAND**

A	B	$\overline{A.B}$
0	0	1
0	1	1
1	0	1
1	1	0

- **Timing diagram of NAND**

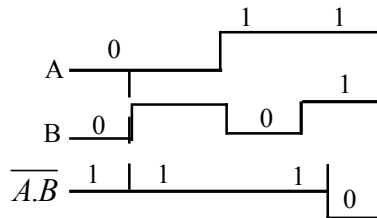

- **NOR Gate**

This is an OR gate is following NOT gates

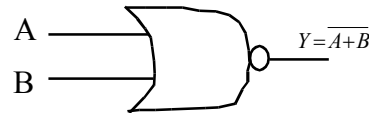
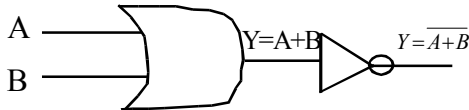

- **Truth table**

A	B	$\overline{A+B} = Y$
0	0	1
0	1	0
1	0	0
1	1	0

- **Timing diagram**

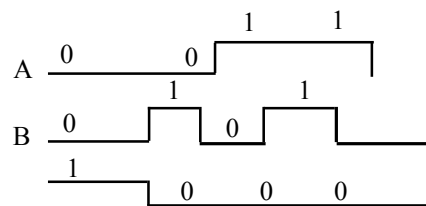

- Which gate and NAND are universal gates because we can obtain all the gate like AND, OR and NOT by using only NOR or NAND.

- Write a note on *IC (Integrated Circuit)*

It is the circuit consisting of passive components like resistor, inductor, capacitor and active devices like diode and transistor on a single block. It is based on Monolithic fabrication technology. The entire fabrication is done in a single silicon crystal called chips.

What is analogue IC

The linear IC's process analogue signals which change smoothly and continuously over a range of values between maximum and minimum the output almost linearly proportional to input. It is used operational amplifiers.

What digital IC's, It is operating by using binary numbers, high and low. They contain logic gates.

- What are different types of ICS-ICS are classified as per no. of components.

ICS type	No. of logic gates
1. Small scale integrated (SSI)	< 10 (less than or equal to 10)
2. Medium scale integral (MSD)	< 100 (less than or equal to 100)
3. Large scale integral (LSI)	< 1000 (less than or equal to 1000)
4. V large scale integral (VLSI)	> (1000 greater than thousand)

Chapter 13

COMMUNICATION SYSTEM

- What is communication - An act of sharing or imparting information.
- What are the steps of communication - It involves sending, processing and receiving information.
- Electrical and Electronic signals are used for long distance communication. Why?
It travels at the speed of light.
- What is Communication system. What are they?
Device which is used for the exchange of information between Sender and Receiver. They are electrical, electronic and optical.
- What are the different parts of communication system -
 - 1) Transmitter - used to convert information signal in to a form (Electromagnetic wave) suitable for transmission.
 - 2) Communication Channel - Medium (path) used for communication.
They are two types,
 - (i) Guided channel - Air, two wire communication channel, OFC.
 - (ii) Unguided channel - Free space.
 - 3) Receiver - used to reconstruct recognisable form of the original information.
- Block diagram of communication system

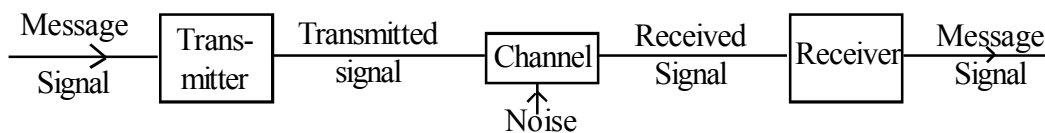

- What are Transducer - A device which converts non-electrical signals (voice, data, video) in to electrical signals (voltage / current)
- Signal - Voltage/current corresponding to the information.
- Microphone is a Transducer - Converts sound energy into electrical pulse.
- Dynamo is a transducer - converts ME in to electrical energy.
- Amplification is necessary for signal communication. Due to attenuation, distortion of signal.
- What is Bandwidth - Frequency range over which an equipment can operate.
- What is spectrum - Frequency band of the Signal OR Arrangement of signals according to their frequency.
- Write frequency band for wireless communication.

AM Radio Broadcast	500 KHz - 1600 KHz
FM Radio Broadcast	88 MHz - 108 MHz
Cellular Phone	896 MHz - 901 MHz - Mobile to Base Station 840 MHz - 935 MHz - Base station to Mobile.
Satellite Communication	5.9 GHz - 6.4 GHz - Uplink. 3.7 GHz - 4.2 GHz - down link.

- Administrator of the present system of frequency allocations (spectrum) - ITU (International Telecommunication union)
- TRAI - Telecom Regulatory Authority of India.
- Different frequency range is used for uplink and downlink. Why?

To avoid interference of signals and to distinguish.

- What is the size of antenna to radiate signals with high efficiency.

Length of the antenna, $l = \frac{\lambda}{4}$

- For AM broadcast ground based antenna (Tower antenna) is used. Why?

Length of the antenna will be large.

eg: Frequency of signal to be transmitted (ν) = 15 KHz.

$$\lambda = \frac{c}{\nu} = \frac{3 \times 10^8}{15 \times 10^3} = 20,000 \text{ m.}$$

∴ Length of the antenna required, $l = \frac{\lambda}{4} = \frac{20000}{4} = 5000\text{m}$

- Range of signal - The largest distance over which signals can be viewed.
- What is repeter? What is its use?
Combination of Transmitter and Receiver - used to extend the range of communication.

- What are the modes of communication.

- 1) Communication through wire (point to point communication)
- 2) Communication through space (Space communication)
- 3) Satellite Communication.

- What is Space communication

The atmosphere of earth used for communication.

There are three modes.

- 1) Ground wave (Surface wave) propagation - Signals transmitted along the earth surface.
- 2) Sky wave propagation (Ionospheric wave) - Signals reflected back to earth by Ionosphere.
- 3) Space wave propagation (Tropospheric wave) - Signals reflected back to earth from Troposphere, Space and Earth surface.

It is also called line of sight communication.

- Microwave is used for line of sight communication.

- Expression for the distance over which Signals can be viewed - (Range of signals)

From ΔOPT , $OT^2 = OP^2 + PT^2$

$$(R+h)^2 = R^2 + d^2$$

$$d^2 = 2Rh + h^2 \quad (\because PT = QP)$$

$$= 2Rh \left(1 + \frac{h}{2R}\right) \quad \text{since } R \gg h$$

$$d = \sqrt{2Rh} \quad \text{Since } 1 + \frac{h}{2R} \sim 1$$

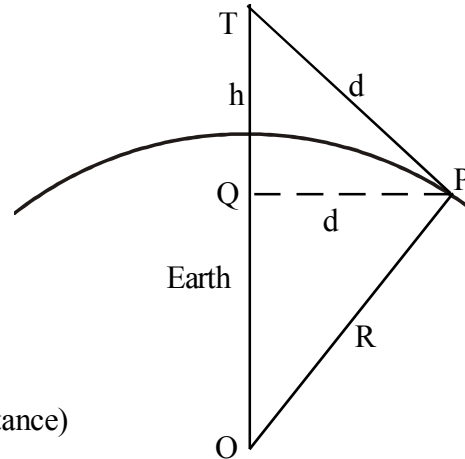

(Note : d - Distance to the horizon - line of sight distance)

\therefore Circular area over which signals can be viewed = πd^2 .

- Sky waves are not suitable for TV signal transmission. Why?

Sky waves are the signals reflected by ionosphere only of frequency below 30 MHz, TV signals of frequency range (100MHz - 200 MHz) are penetrate through Ionosphere.

- Explain Satellite communication

Space wave (eg.: Microwave) used for satellite communication

Communication Satellite is a space craft which carries on board microwave transmitting and receiving equipment (Transponder). Such a satellite is Geostationery Satellite.

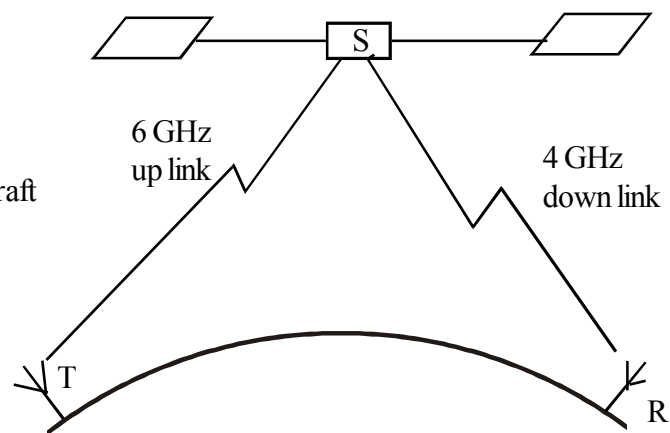

Eg.: INSAT

- What is modulation - The process of super imposing low frequency signals with high frequency signals - The signals obtained after modulation are modulated signals.

Low frequency signals - Modulating (base band) signal.

High frequency signals - Carries wave.

- What are the needs of modulation-
 - (i) Long distance broad casting
 - (ii) Height of the antenna is low as possible
 - (iii) Avoid chances of interference of signals

- Modulated signal for transmission requires high frequency - Why?

For good transmission of signal high power is required. It is obtained at high frequency ($E\alpha v$).

- Power radiated from a linear antenna is $(\frac{\ell}{\lambda})^4 P$ ℓ - for length of antenna, λ - wave length of signal.

- What are the types of modulation-

I Continuous wave (sinusoidal) modulation.

- a) Amplitude modulation (AM)
- b) Frequency modulation (FM)
- c) Phase modulation (PM)

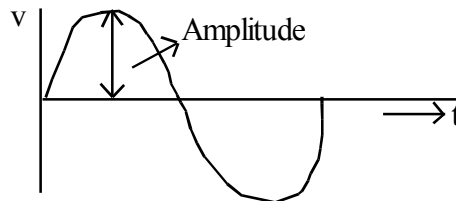

II Pulse modulation

- a) Pulse Amplitude Modulation (PAM)
- b) Pulse Position Modulation (PPM)
- c) Pulse Width Modulation (PWM)

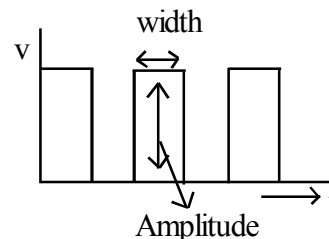

- Amplitude Modulation (AM)

Variation in amplitude of carrier wave in accordance with base band signal.

- Graphical representation of AM.

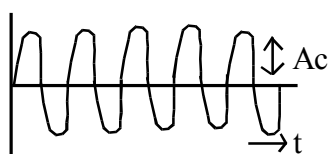

$$C(t) = A_c \sin \omega_c t$$

(Carrier signal)

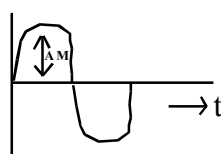

$$m(t) = A_m \sin \omega_m t$$

(Base Based signal)

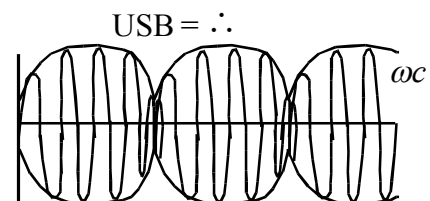

$$USB = \omega_c + \omega_m$$

$$LSB = \omega_c - \omega_m$$

AM Signal

- Analyse of AM.

$$C(t) = A_c \sin \omega_c t, \text{ Carrier Signal}$$

$$M(t) = A_m \sin \omega_m t, \text{ Base hand signal}$$

Amplitude modulated signal

$$C_m(t) = (A_c + A_m \sin \omega_m t) \sin \omega_c t \text{ (Since Amplitude of AM Signal increases)}$$

$$= A_c \left(1 + \frac{Am}{Ac} \sin \omega_m t \right) \sin \omega_c t$$

$$= A_c \sin \omega_c t + \mu A_c \sin \omega_c t \sin \omega_m t$$

$$C_m(t) = A_c \sin \omega_c t + \frac{\mu A_c}{2} \cos(\omega_c - \omega_m)t - \frac{\mu A_c}{2} \cos(\omega_c + \omega_m)$$

Where, $\mu = \frac{Am}{Ac}$, Modulation Index,

$$2 \sin A \sin B = \cos(A-B) - \cos(A+B)$$

Percentage of Am, $\frac{Am}{Ac} 100\%$

Modulated signal $[C_m C(t)]$ consists of three frequencies,

- (i) ω_c - Carrier signal frequency
- (ii) $\omega_c + \omega_m$ = USB, Upper Side Band frequency
- (iii) $\omega_c - \omega_m$ = LSB, Lower Side Band frequency

- Expression for Band width (β)

$$\beta = \text{USB} - \text{LSB}$$

$$= \omega_c + \omega_m - \omega_c + \omega_m$$

$$= 2\omega_m \text{ where } \omega_m = 2\pi f_m$$

- Draw AM Spectrum

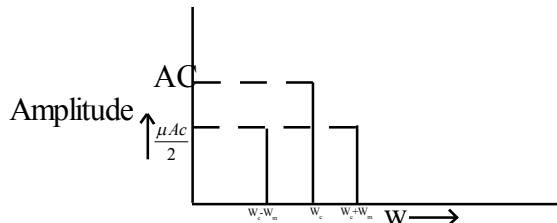

- Production of AM wave (Block diagram)

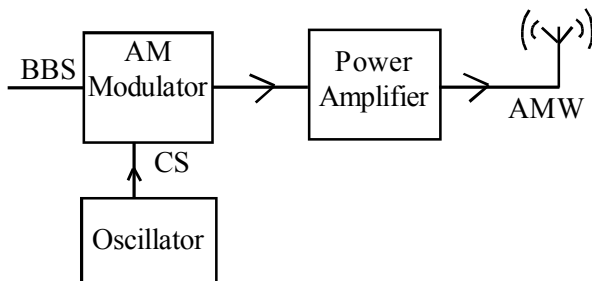

- Use of AM:-

In Radio and TV sound broadcasting.

- Limitations of AM
 - (i) Low efficiency
 - (ii) Noisy Reception
 - (iii) Small operating range
 - (iv) Lack of audio quality

Eg:- For an AMW the maximum amplitude is 10V while minimum amplitude 2V.

- (i) Determine modulation index

$$\text{AMW, } C_m(t) = (A_c + A_m \sin w_m t) \sin w_c t$$

$$\text{Maximum amplitude, } A_c + A_m = M_1$$

$$\text{Minimum amplitude, } A_c - A_m = M_2$$

$$\text{Modulation Index } \mu = \frac{Am}{Ac} = \frac{M_1 - M_2}{M_1 + M_2}$$

$$\mu = \frac{8}{12} = 0.67$$

- (ii) What would be the value of modulation index (μ) if minimum amplitude is, zero volt

$$\mu = 1$$

- To avoid distortion of signal (weaking of signal) modulation index, $\mu \leq 1$

- Given $m(t) = 20 \sin 2\pi (2000)t$, $c(t) = 80 \sin 2\pi (100000)t$.

Determine,

- i) Percentage of modulation
- ii) Frequency of Baseband and carrier signals
- iii) Frequency spectrum of modulated wave.
- iv) Band Width

$$\text{i) Percentage of modulation} = \frac{Am}{Ac} 100$$

$$= \frac{20}{80} 100 = 25\%$$

$$\text{ii) } m(t) = Am \sin (2\pi\vartheta_m t)$$

$$m(t) = 20 \sin 2\pi (2000)t$$

$$\therefore \vartheta_m = 2000 \text{ Hz}$$

$$C(t) = Ac \sin 2\pi \vartheta_c t$$

$$C(t) = 80 \sin 2\pi (100000)t$$

$$\therefore \vartheta_c = 100000 \text{ Hz}$$

- (iii) Frequency spectrum of modulated wave

$$\vartheta_c = 100000 \text{ Hz} \Rightarrow 100 \text{ KHz}$$

$$LSB = \nu_c - \nu_m : 10000 - 2000 \Rightarrow 98000Hz \Rightarrow 98KHz$$

$$USB = \nu_c + \nu_m : 10000 + 2000 \Rightarrow 102000Hz \Rightarrow 102KHz$$

Spectrum is 98KHz - 100KHz - 102KHz

(iv) Band width $\beta = USB - LSB$
 $= 102 - 98$
 $= 4KHz$

- Communication systems are mostly analogue
 - (i) Natural signals are analogue
 - (ii) More complexity for digital systems
- Electric current be used as carrier signal - No - But electro magnetic wave form is used.
- Antena as transmitter converts electrical signals into EM wave, as receiver it converts EM wave into electrical signals.
- At low frequency (Eg. Sound) signal is propagated in all directions - It is not transmitted over distant place due to large absorption of air.
- High frequency signal (Eg: Microwave) travels along a straight line. So for their reception either Geostationary satellite or receiver antena are required.

* * *