

# MANUAL DE MONTAGEM

ASSEMBLY INSTRUCTIONS

INSTRUCCIONES DE MONTAJE

NOTICE DE MONTAGE

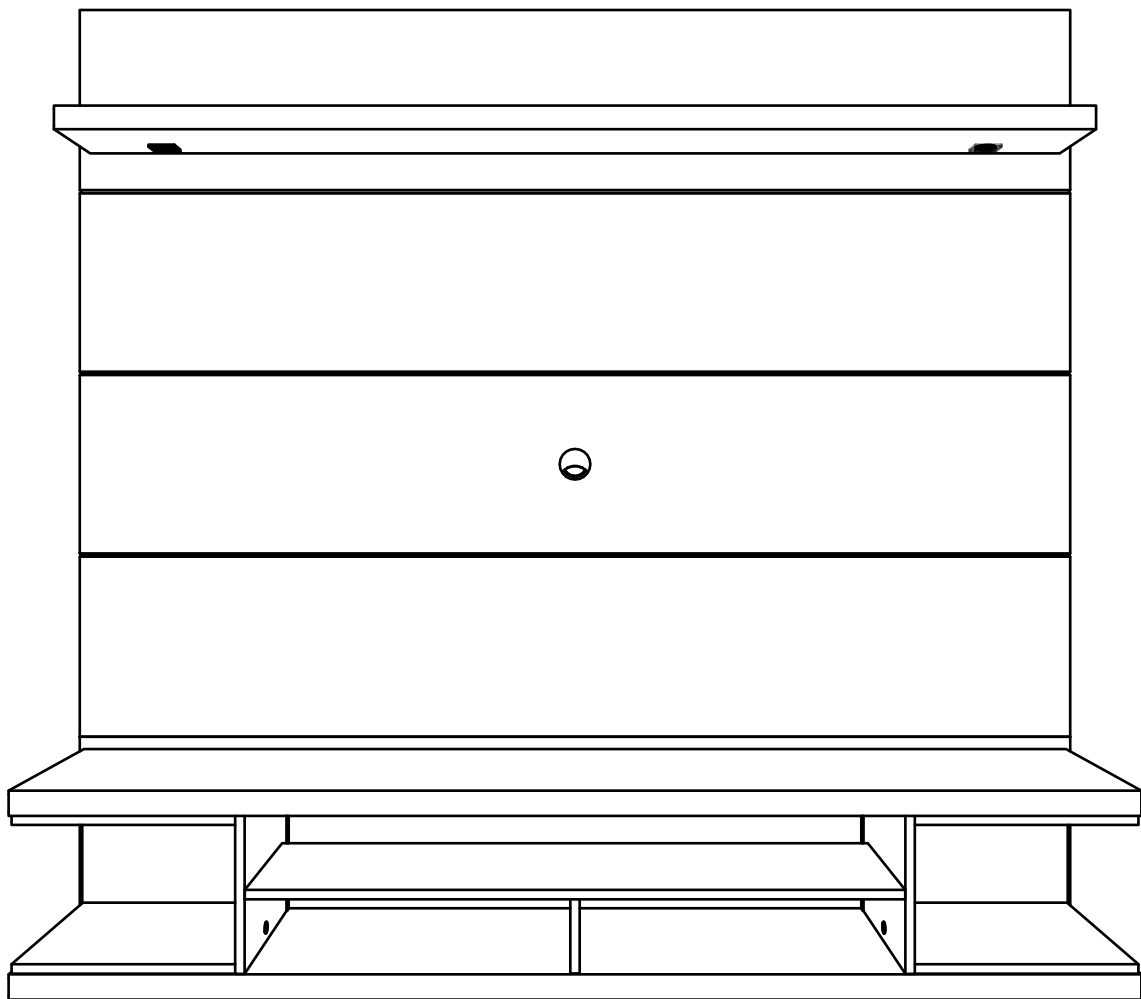

COD:27900

REV. 09 - 03/04/23

# OBSERVAÇÕES IMPORTANTES IMPORTANT REMARKS OBSERVACIONES IMPORTANTES REMARQUES IMPORTANTES



Nunca escale ou se apoie sobre o móvel. Você pode sofrer graves acidentes.

Never climb or lean on the furniture. You may suffer serious accidents.

Nunca escale o apoie sobre el mobiliario. Usted puede sufrir graves accidentes.

Ne montez jamais sur le meuble. Vous pourriez subir un grave accident.

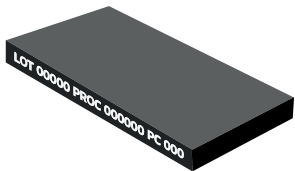

Observe os números impressos nas bordas para identificar as peças.

Identify the parts by observing the number printed on their edges.

Identifique las piezas observando el numero impreso en sus bordes.

Notez les numéros imprimés sur les bords pour identifier les pièces.



Movimente o móvel com cuidado, sem arrastar. Peça ajuda a outra pessoa para fazê-lo.

Move the piece carefully, don't drag it. Ask for someone else's help to do so.

Mover la unidad con cuidado, sin arrastar. Pedir ayuda da otra persona para moverlo.

Déplacez les meubles avec précaution sans le faire glisser. Demandez a quelqu'un de vous aider à le faire.

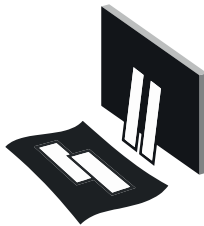

Utilize a embalagem para forrar a área de montagem e separar todas as peças.

Use the packaging to cover the assembly area and separate all parts.

Utilice el embalaje para cubrir la area de montaje y separe las piezas.

Couvrez la zone d'assemblage avec l'emballage pour séparer le pièces.



Limpe com um pano limpo e umedecido em água e sabão neutro. Não utilizar produtos químicos e abrasivos.

Wipe clean using a damp cloth and a mild cleaner. Don't use abrasive and chemical products.

Limpie con un paño limpio humedecido con agua y jabón neutro. No utilice productos químicos y abrasivos.

Nettoyez avec un chiffon propre imbibé avec d'eau et de savon doux. N'utilisez pas de produits chimiques et abrasifs.



Não colocar objetos em alta temperatura diretamente sobre superfícies de vidro.

Do not place high-temperature objects directly on glass surfaces.

No coloque objetos de alta temperatura directamente sobre superficies de vidro.

Ne placez pas d'objets à haute température directement sur les surfaces en verre.

# ACESSÓRIOS HARDWARE HERRAJES ACCESSOIRES

Identifique e separe os acessórios utilizados. Em cada embalagem, uma etiqueta identifica as peças e onde utilizá-las.

Identify and separate the hardware used in the assembly. There's a label on each package identifying the parts and where to use them.

Identifique y separete los accesorios utilizados en el montaje. Observe la etiqueta en cada paquete para saber donde montar.

Identifiez et séparez les accessoires à être utilisés. Dans chaque emballage il y a une étiquette pour identifier les pièces et où les utiliser.

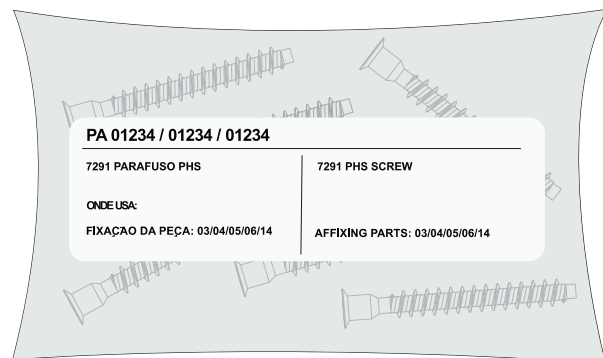

## PA27900 - 1810mm









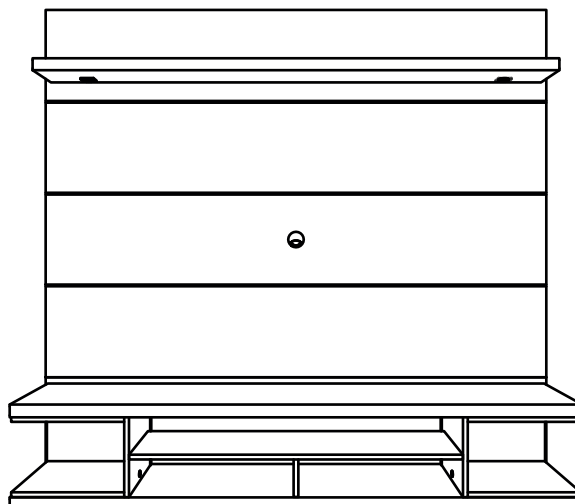

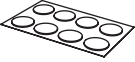

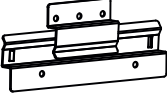
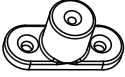
L:1810mm A:1708mm P:393mm

W:71.26in H:67.24in D:15.47in

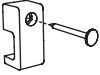
L:1810mm A:1708mm P:393mm

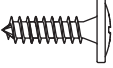
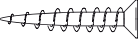
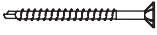
L:1810mm H:1708mm P:393mm



<p>ADESIVO - 10x STICKER ADHESIVO AUTOCOLLANT</p>  <p><b>A</b></p>	<p>COD. 10063-12x</p>  <p><b>B</b></p>	<p>COD. 1668-33x 6.0 X 30</p>  <p><b>C</b></p>	<p>COD. 9070-6x</p>  <p><b>D</b></p>	<p>COD. 4157-14x</p>  <p><b>E</b></p>
<p>LED-1x</p>  <p><b>F</b></p>	<p>PASSA FIO - 2x WIRE CHANNEL PASAJE DE ALAMBRE PASSE-CÂBLES</p>  <p><b>G</b></p>	<p>COD. 0348-2x</p>  <p><b>H</b></p>	<p>COD. 2088-14x UX8</p>  <p><b>I</b></p>	<p>COD. 6024-04x</p>  <p><b>J</b></p>
<p>COD. 0599-12x</p>  <p><b>K</b></p>	<p>COD. 0160-28x 4.0 X 12</p>  <p><b>L</b></p>	<p>COD. 3557-18x 4.0 X 14</p>  <p><b>M</b></p>	<p>COD. 3706-30x 4.0 X 30</p>  <p><b>N</b></p>	<p>COD. 3527-16x 4.0 X 45</p>  <p><b>O</b></p>
<p>SUPORTE TV - 1x TV MOUNT SOPORTE TV SUPPORT MURAL POUR TV</p> <p><b>P</b></p>	<p>COD. 9333-8x 5.0 X 50</p>  <p><b>Q</b></p>	<p>COD. 6244-12x 6.0 X 65</p>  <p><b>R</b></p>	<p>COD. 4505-2x 6.0 X 100</p>  <p><b>S</b></p>	

ASSEMBLY REQUIRES 2 PEOPLE  
EL MONTAJE NECESITA 2 PERSONAS  
MONTAGE A 2 PERSONNES

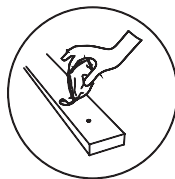

**Passe cola PVA antes de parafusar.**  
Use the PVA glue before screwing.  
Use pegamento PVA antes de atornillar.  
Utilisez de la colle PVA avant de visser.

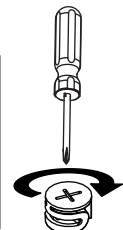
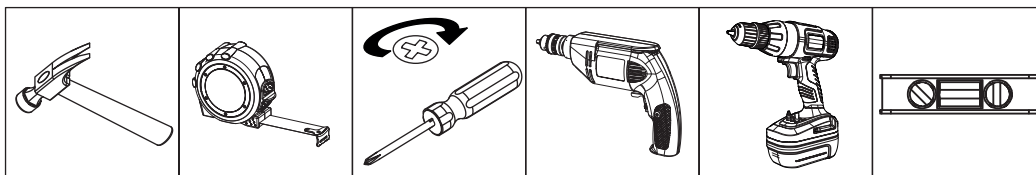

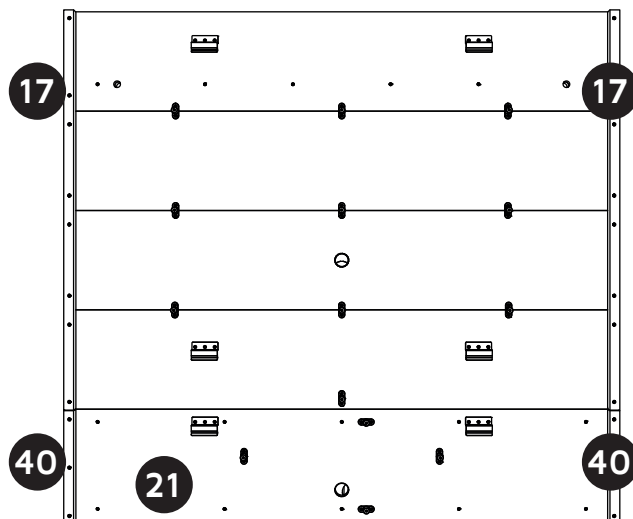
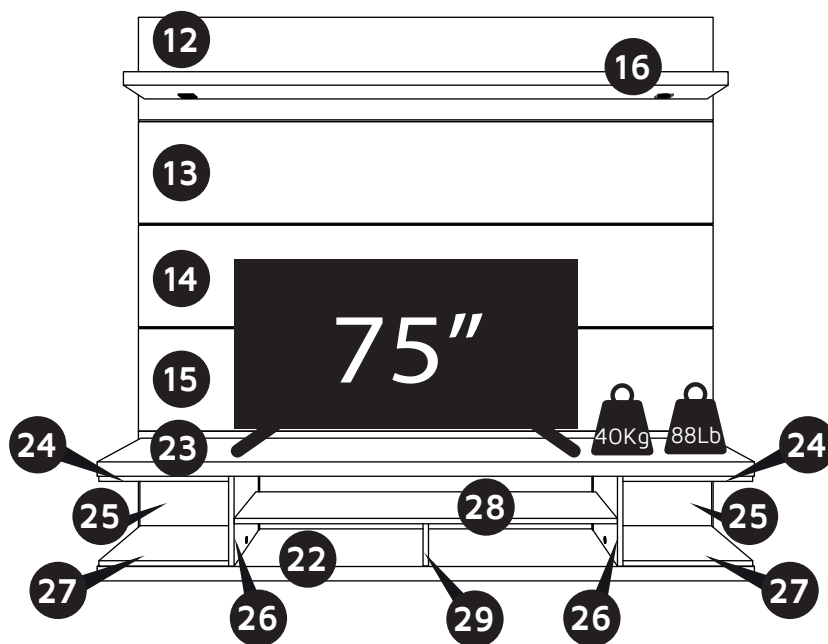

# DESCRIÇÃO/ DESCRIPTION/ DESCRIPCIÓN/ DESCRIPTION

CÓD:27900						
PEÇA PART PIEZA PIÈCE	QUANTIDADE QUANTITY CANTIDAD QUANTITÉ	DESCRIÇÃO	DESCRIPTION	DESCRIPCIÓN	DESCRIPTION	CAIXA BOX CAJA BOÎTE
12	01	PAINEL SUPERIOR	TOP PANEL	PANEL SUPERIOR	PANNEAU SUPÉRIEUR	01
13	01	PAINEL CENTRAL	TOP PANEL	PANEL SUPERIOR	PANNEAU SUPÉRIEUR	01
14	01	PAINEL PASSA FIO	WIRE PASSAGE PANEL	PANEL DE ALAMBRE	PANNEAU DE PASSAGE DE FILS	01
15	02	PAINEL INFERIOR	BACK PANEL	PANEL INFERIOR	PANNEAU INFÉRIEUR	01
16	02	PRATELEIRA	TOP SHELF	ESTANTE	ÉTAGÈRE	01
17	02	SARRAFO TRASEIRO	BACKSIDE BATTEN	SOPORTE TRASERO	LATTE DERRIÈRE	02
21	02	FUNDO	BACK PANEL	FONDO	FOND	01
22	01	BASE	BASE	BASE	BASE	01
23	01	TAMPO	TOP PANEL	PANEL SUPERIOR	PLATEU	01
24	02	PAINEL SUP. NICHOS	NICHE TOP PANEL	SUPERIOR NICHOS	LATTES INFÉRIEURES	02
25	02	FUNDO NICHOS	NICHE BACK PANEL	FONDO NICHOS	FOND DE L'ÉTAGÈRE CARRÉ	02
26	02	LATERAL NICHOS	SIDE NICHE	NICHOS LATERAL	ÉTAGÈRE CARRÉ CÔTÉ	02
27	02	INFERIOR NICHOS	NICHE BOTTOM	NICHOS INFERIOR	BAS DE L'ÉTAGÈRE CARRÉ	02
28	01	DIVISÓRIA MAIOR	LONG DIVIDER	DIVISION MAYOR	DIVISEUR PLUS GRAND	01
29	01	DIVISÓRIA MENOR	SHORT DIVISION	DIVISOR MENOR	DIVISEUR PLUS PETITE	01
40	02	SARRAFO INFERIOR	BOTTOM BATTEN	SOPORTE INFERIOR	LATTES INFÉRIEURES	02



01

<b>C</b> COD. 1668	<b>K</b> COD. 0599
	

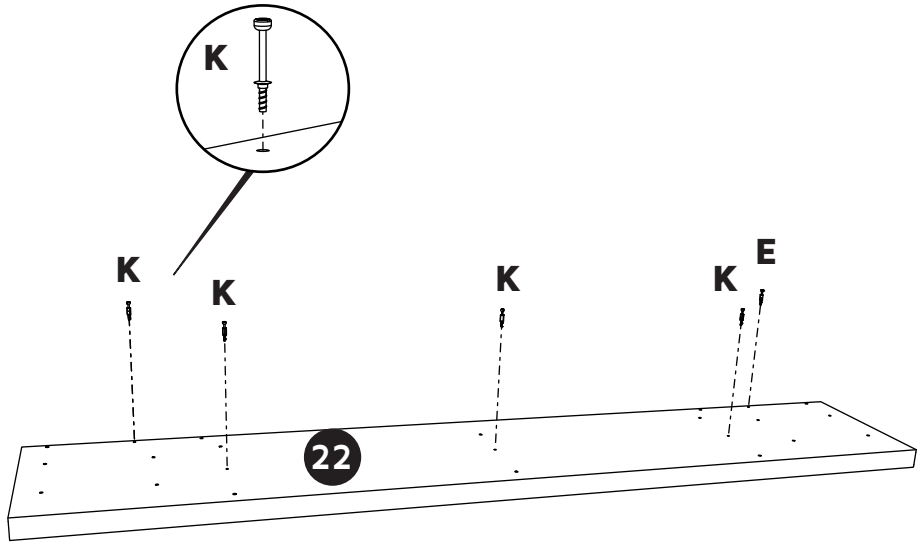

PASSO 01  
Parafusar minifix 5x**0599**  
na base **22**

STEP 01  
Screw minifix 5x**0599**  
on base **22**

PASO 01  
Atornillar el minifix 5x**0599**  
en la base **22**

ÉTAPE 01  
Vissez le minifix 5x**0599**  
dans la base **22**

02

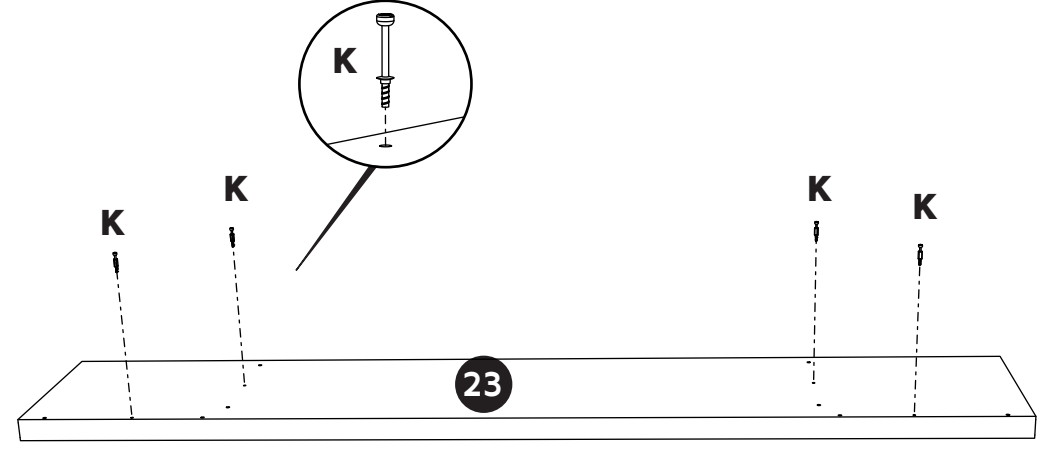

PASSO 02  
Parafusar minifix 4x**0599**  
no tampo **23**

STEP 02  
Screw minifix 4x**0599**  
on top board **23**

PASO 02  
Atornillar el minifix 4x**0599**  
en la cubierta **23**

ÉTAPE 02  
Vissez le minifix 4x**0599**  
dans le plateau **23**

03

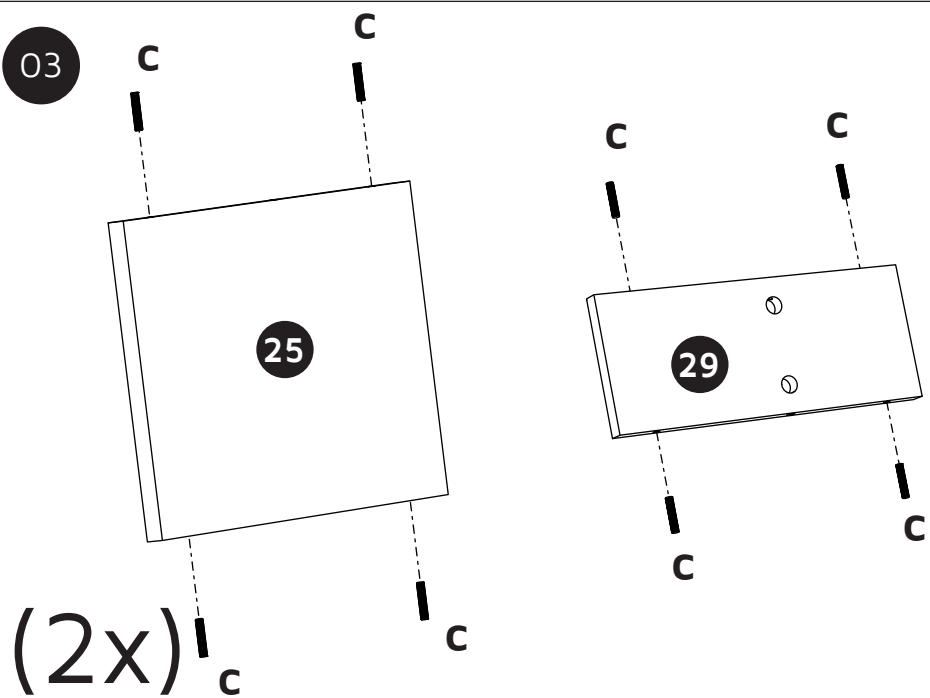

PASSO 03  
Encaixar cavilhas 4x**1668** no fundo  
nicho **25**/ divisória menor **29**

STEP 03  
Insert dowels 4x**1668** on the niche  
back panel **25**/ short divider **29**

PASO 03  
Clavijas de ajuste 4x**1668**  
en fondo nicho **25**/ division menor **29**

ÉTAPE 03  
Insérez les chevilles 4x**1668** en bois  
dans les fentes du fond de la niche  
**25**/ diviseur plus petite **29**

04

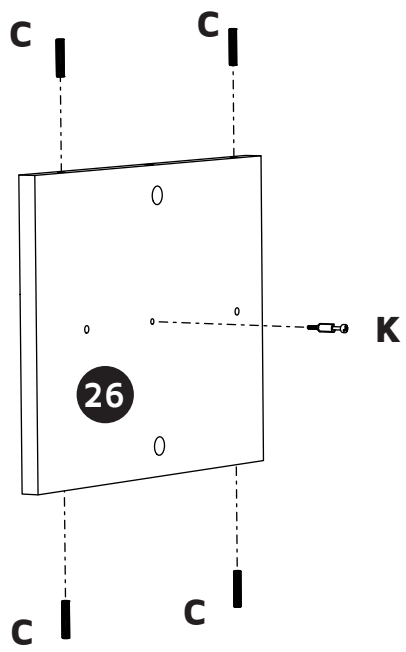

<b>C</b> COD. 1668 	<b>D</b> 	<b>E</b> 	<b>K</b> COD. 0599 	<b>L</b> COD. 0160 	<b>M</b> COD. 3557 
---------------------------	--------------	--------------	---------------------------	---------------------------	---------------------------

PASSO 04  
Encaixar cavilhas 4x**1668** e parafusar minifix 1x**0599** na lateral nicho **26**

STEP 04  
Insert dowels 4x**1668** and screw minifix 1x**0599** on side niche **26**

PASO 04  
Clavijas de ajuste 4x**1668** y atornillar el minifix 1x**0599** en nicho lateral **26**

ÉTAPE 04  
Insérez les chevilles 4x**1668** en bois et vissez le minifix 1x**0599** dans le côté gauche de la niche **26**

(2x)

05

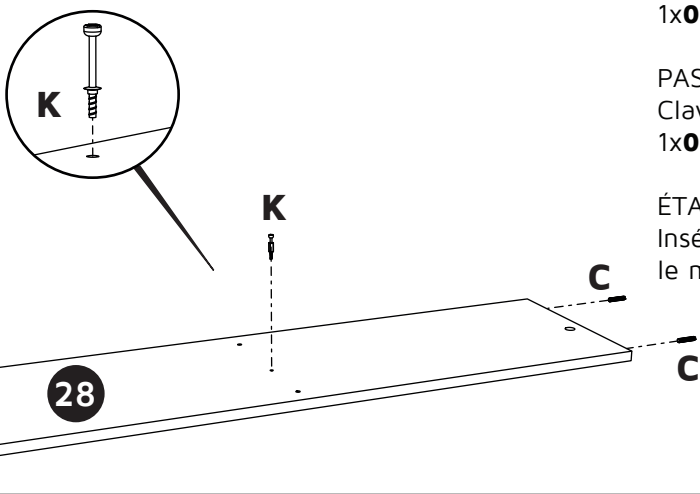

PASSO 05  
Encaixar cavilhas 4x**1668** e parafusar minifix 1x**0599** na divisória maior **28**

STEP 05  
Insert dowels 4x**1668** and screw minifix 1x**0599** on long divider **28**

PASO 05  
Clavijas de ajuste 4x**1668** y atornillar el minifix 1x**0599** en la division mayor **28**

ÉTAPE 05  
Insérez les chevilles 4x**1668** en bois et vissez le minifix 1x**0599** dans le diviseur plus grand **28**

06

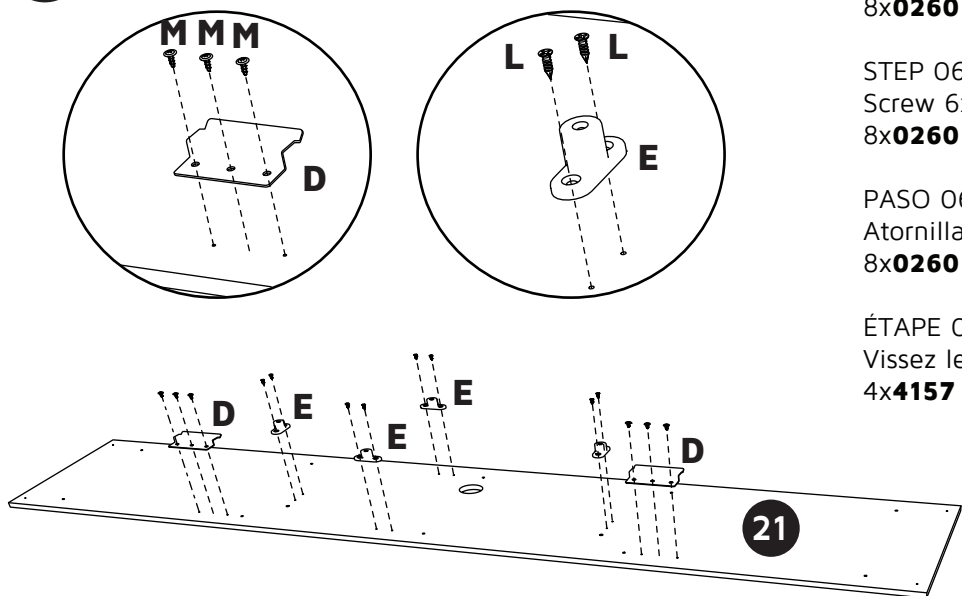

PASSO 06  
Parafusar 6x**3557** 2x**9070**/  
8x**0260** 4x**4157** no fundo **21**

STEP 06  
Screw 6x**3557** 2x**9070**/  
8x**0260** 4x**4157** on back panel **21**

PASO 06  
Atornillar 6x**3557** 2x**9070**/  
8x**0260** 4x**4157** en el fondo **21**

ÉTAPE 06  
Vissez le 6x**3557** 2x**9070**/ 8x**0260** 4x**4157** et fond **21**

07

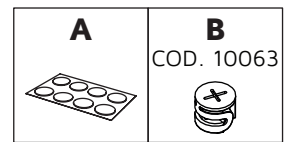
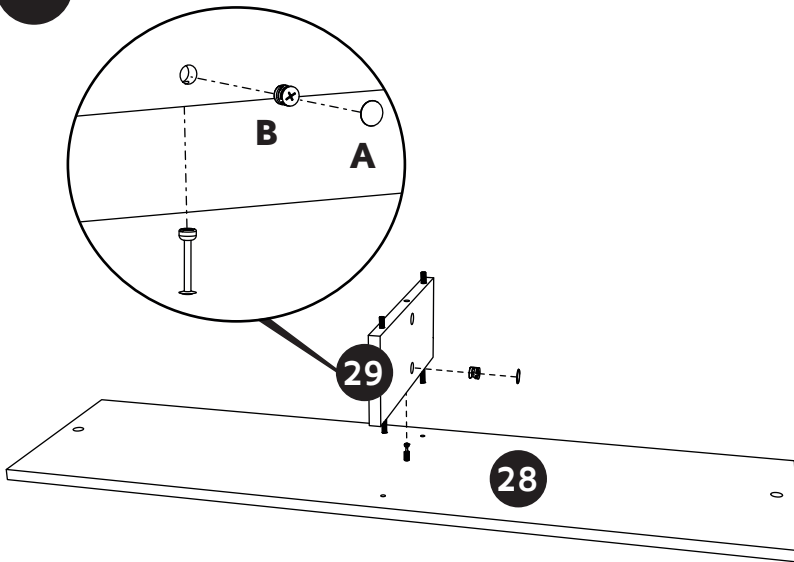

PASSO 07

Encaixar divisória menor **29** parafusar minifix 1x**10063** e colar **1** adesivo

STEP 07

Attach divider **29** Screw nuts 1x**10063** and place **1** sticker

PASO 07

Enganchar la division **29** Atornillar las tuercas 1x**10063**y pegar **1** adhesivo

ÉTAPE 07

Insérez le diviseur plus petite **29** Vissez le minifix 1x**10063** et collez **1** l'adhésif

08

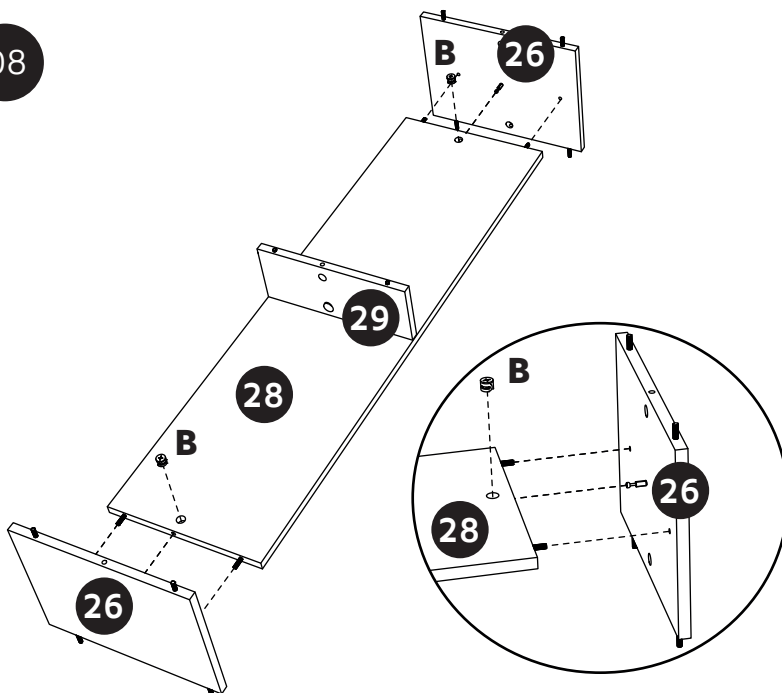

PASSO 08

Encaixar laterais nicho **26** Parafusar castanhas 2x**10063**

STEP 08

Attach sides **26** Screw nuts 2x**10063**

PASO 08

Montarlas laterales **26** Atornillar las tuercas 2x**10063**

ÉTAPE 08

Insérez les le côté gauche de la niche **26** Vissez le brunette 2x**10063**

09

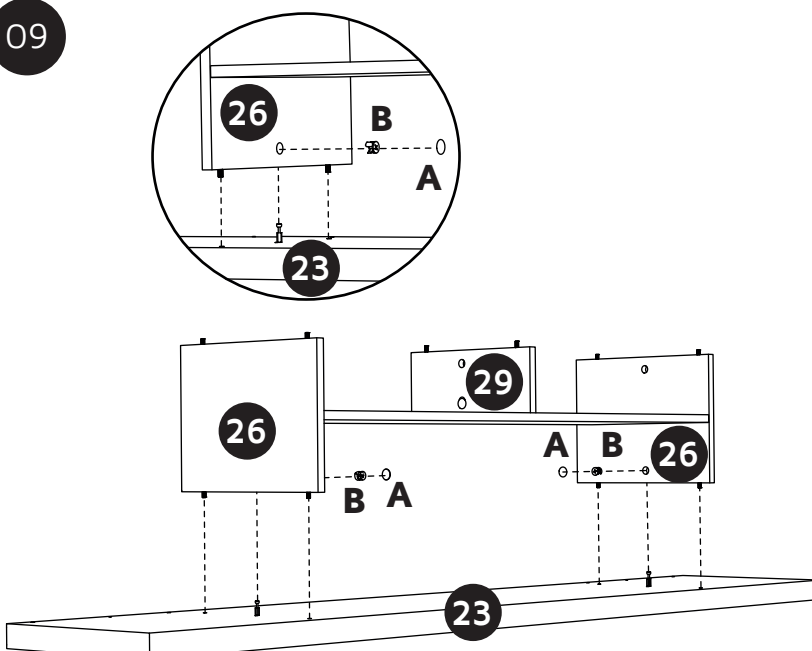

PASSO 09

Encaixar laterais nicho **26** Parafusar castanhas 2x**10063**e colar **2** adesivos

STEP 09

Attach sides **26** Screw nuts 2x**10063** and place **2** stickers

PASO 09

Montar las laterales **26** Atornillar las tuercas 2x**10063**y pegar **2** adhesivos

ÉTAPE 09

Insérez les le côté gauche de la niche **26** Vissez le brunette 2x**10063** et collez **1** l'adhésif



10

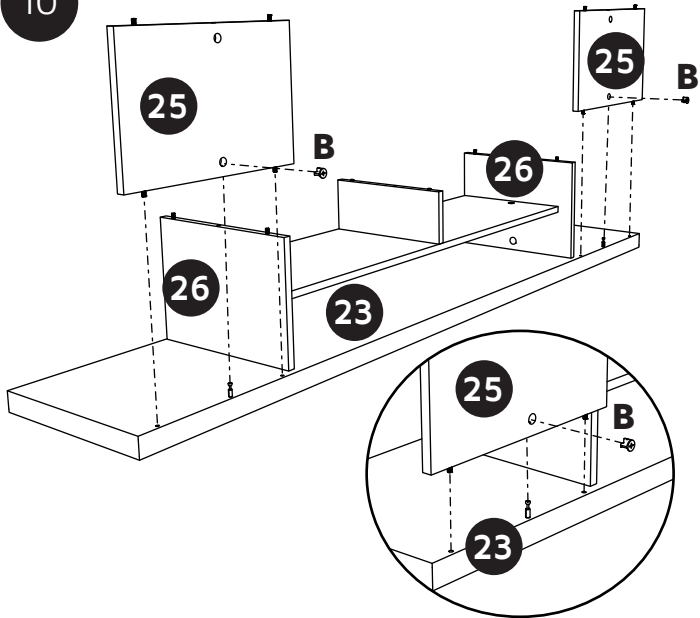

<b>A</b> 	<b>B</b> COD. 10063 	<b>N</b> COD. 3706 
--------------	----------------------------	---------------------------

PASSO 10  
Encaixar fundo nicho **25**  
Parafusar castanhas 2x**10063**

STEP 10  
Attach niche back **25**  
Screw nuts 2x**10063**

PASO 10  
Montar el fondo nicho **25**  
Atornillar las tuercas 2x**10063**

ÉTAPE 10  
Insérez le fond de la niche **25**  
Vissez le brunette 2x**10063**

11

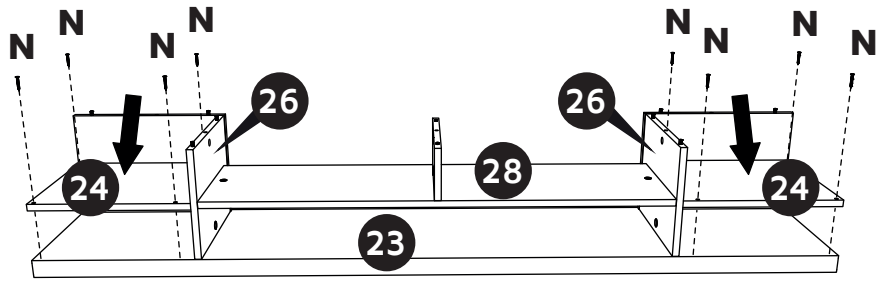
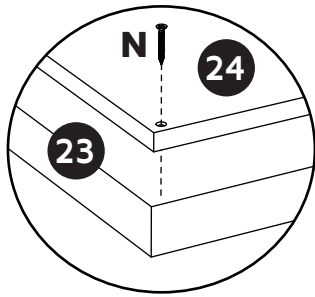

PASSO 11  
Encaixar painel sup. nicho **24**  
Parafusar 8x**3706**

STEP 11  
Attach niche top **24**  
Screw 8x**3706**

PASO 11  
Montar el panel superior **24**  
Atornillar 8x**3706**

ÉTAPE 11  
Insérez le lattes inférieures **24**  
Vissez 8x**3706**

12

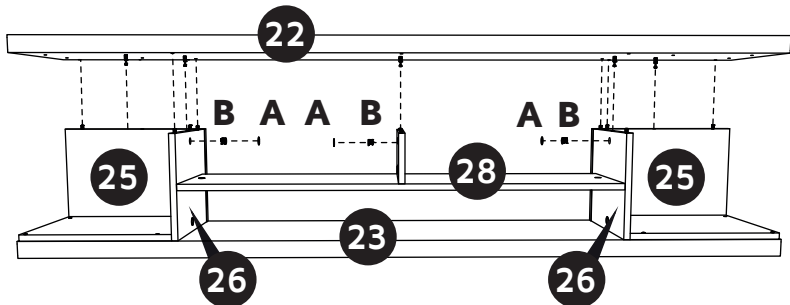
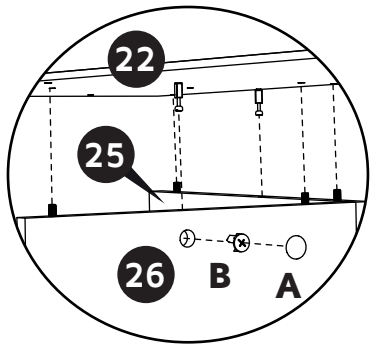





PASSO 12  
Encaixar base **22**  
Parafusar castanhas 3x**10063** e  
colar **3** adesivo

STEP 12  
Attach base **22**  
Screw nuts 3x**10063**  
and place **3** stickers

PASO 12  
Montar base **22**  
Atornillar las tuercas 3x**10063**  
y pegar **3** adhesivos

ÉTAPE 12  
Insérez le base **22**  
Vissez le brunette 3x**10063** et collez  
**3** l'adhésif

13

<b>B</b> COD. 10063 	<b>C</b> COD. 1668 	<b>H</b> 	<b>O</b> COD. 3527 
---------------------------------------------------------------------------------------------------------------	--------------------------------------------------------------------------------------------------------------	-------------------------------------------------------------------------------------------------	--------------------------------------------------------------------------------------------------------------

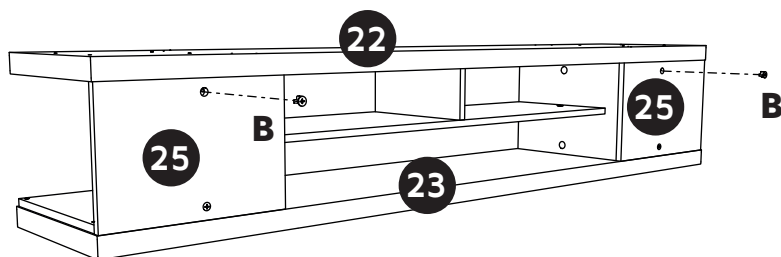

PASSO 13  
Parafusar castanhas 2x**10063**

STEP 13  
Screw nuts 2x**10063**

PASO 13  
Atornillar las tuercas 2x**10063**

ÉTAPE 13  
Vissez le brunette 2x**10063**

14

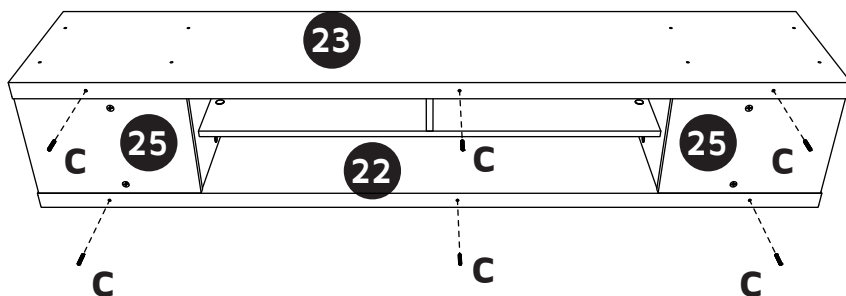

PASSO 14  
Encaixar cavilhas 6x**1668**

STEP 14  
Insert dowels 6x**1668**

PASO 14  
Clavijas de ajuste 6x**1668**

ÉTAPE 14  
Insérez les chevilles 6x**1668**

15

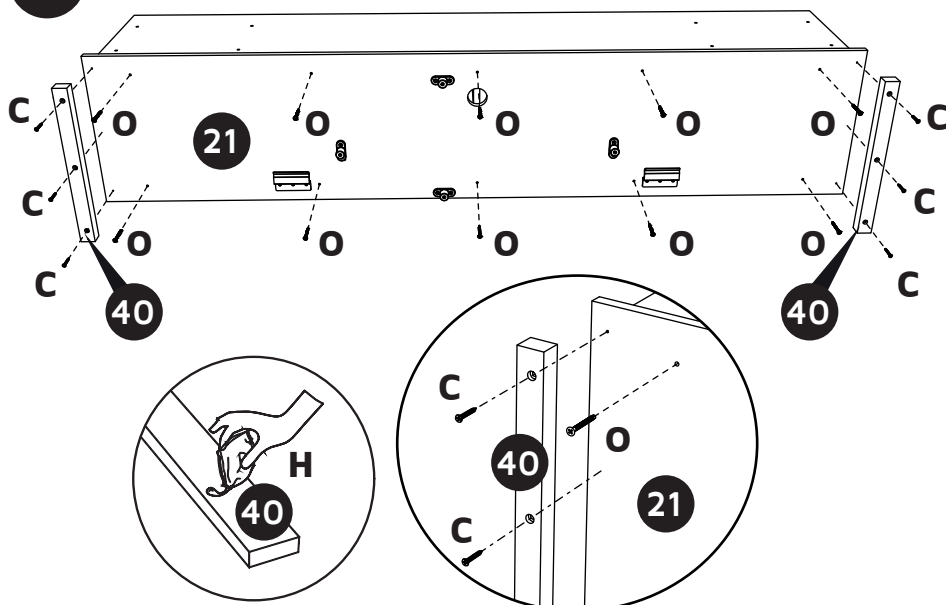

PASSO 15  
Passar cola **H** e parafusar 6x**1668**  
sarrafo inferior **40** no fundo **21**  
Parafusar 10x**3527** no fundo **21**

STEP 15  
Pass glue **H** and screw 6x**1668**  
bottom batten **40** on the back  
panel **21**  
Screw 10x**3527** on the back  
panel **21**

PASO 15  
Passar pegamento **H** y atornillar  
6x**1668** soporte inferior **40** en  
el fondo **21**  
Atornillar 10x**3527** en el fondo **21**

ÉTAPE 15  
Pass cole **H** et vissez 6x**1668**  
lattes inférieures **40** et fond **21**  
Vissez 10x**3527** et fond **21**

16

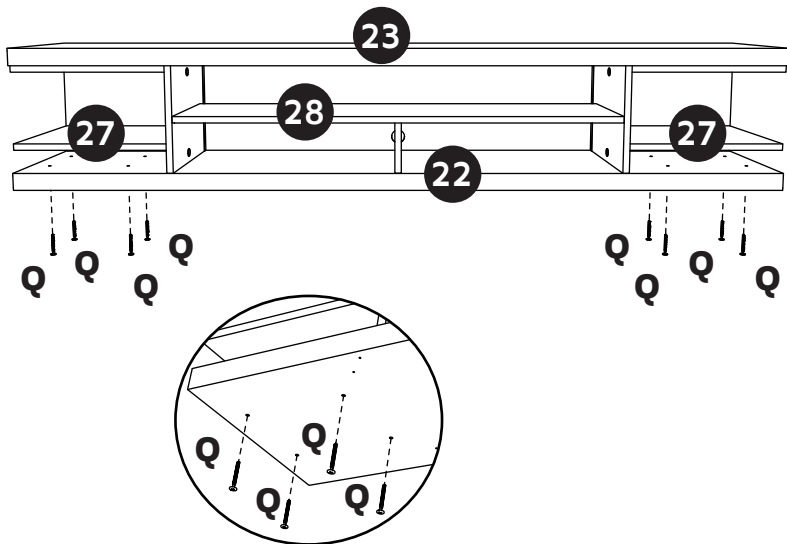

<b>C</b> COD. 1668	<b>F</b> COD. 9333	<b>Q</b> COD. 9333

PASSO 16  
Encaixar inferior nicho **27**  
Parafusar 8x**9333**

STEP 16  
Attach bottom niche **27**  
Screw 8x**9333**

PASO 16  
Montar el fondo nicho **27**  
Atornillar 8x**9333**

ÉTAPE 16  
Insérez le bas de l'étagère carré **27**  
Vissez 8x**9333**

17

PASSO 17  
Passar os fios do kit led **F**  
e encaixar as cavilhas 3x**1668**





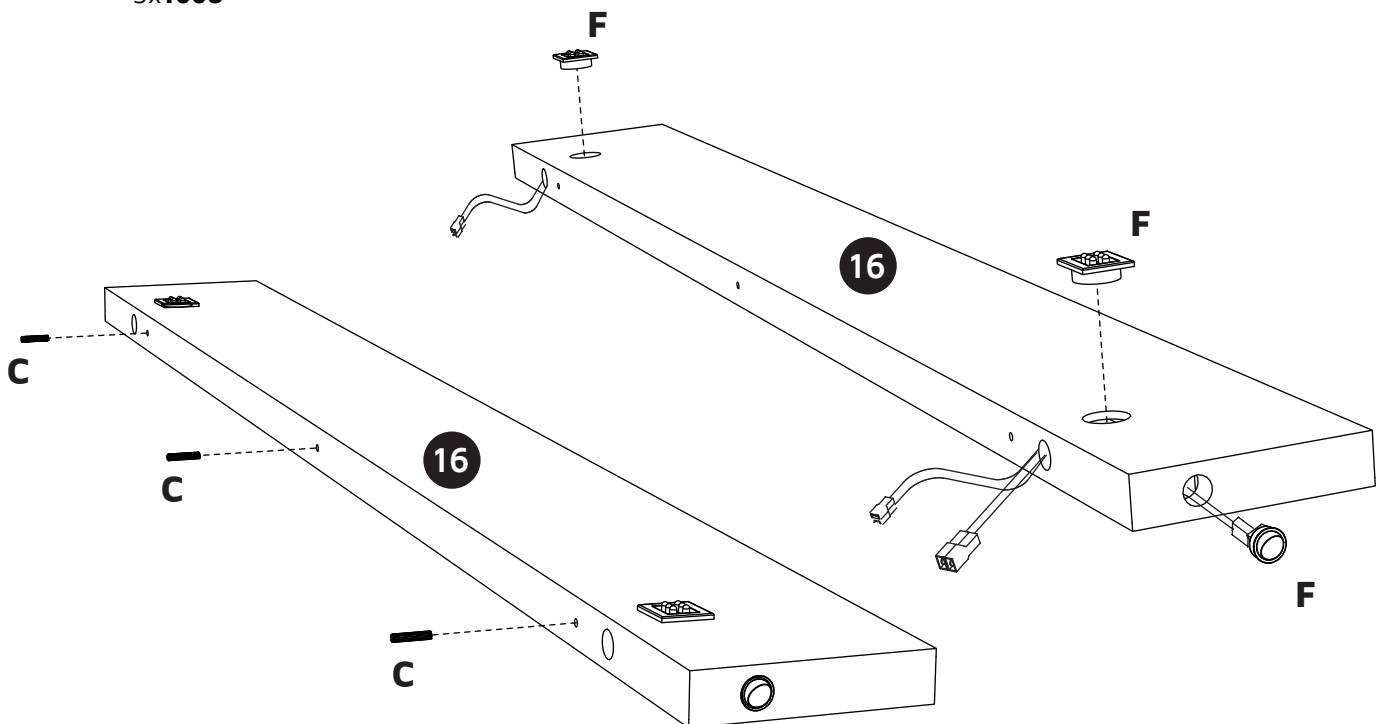
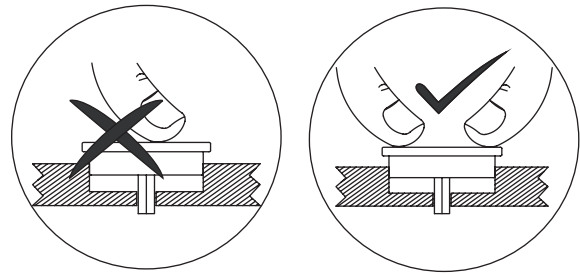

STEP 17  
Pass the wires of the led kit **F**  
and insert dowels 3x**1668**

PASO 17  
Pasar los cables del kit led **F**  
y clavijas de ajuste 3x**1668**

ÉTAPE 17  
Faire fonctionner les fils du  
kit led **F** et insérez les chevilles  
3x**1668**



18

<b>D</b> COD. 9070 	<b>E</b> COD. 4157 	<b>H</b> 	<b>L</b> COD. 0160 	<b>M</b> COD. 3557 	<b>N</b> COD. 3706 
------------------------------------------------------------------------------------------------------------	------------------------------------------------------------------------------------------------------------	-------------------------------------------------------------------------------------------------	--------------------------------------------------------------------------------------------------------------	--------------------------------------------------------------------------------------------------------------	--------------------------------------------------------------------------------------------------------------

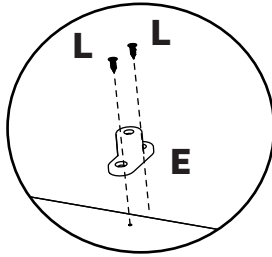
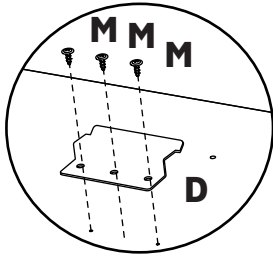

PASSO 18  
Parafusar 12x**3557** 4x**9070**  
Parafusar 20x**0160** 10x**4157**

STEP 18  
Screw 12x**3557** 4x**9070**  
Screw 20x**0160** 10x**4157**

PASO 18  
Atornillar 12x**3557** 4x**9070**  
Atornillar 20x**0160** 10x**4157**

ÉTAPE 18  
Vissez 12x**3557** 4x**9070**  
Vissez 20x**0160** 10x**4157**

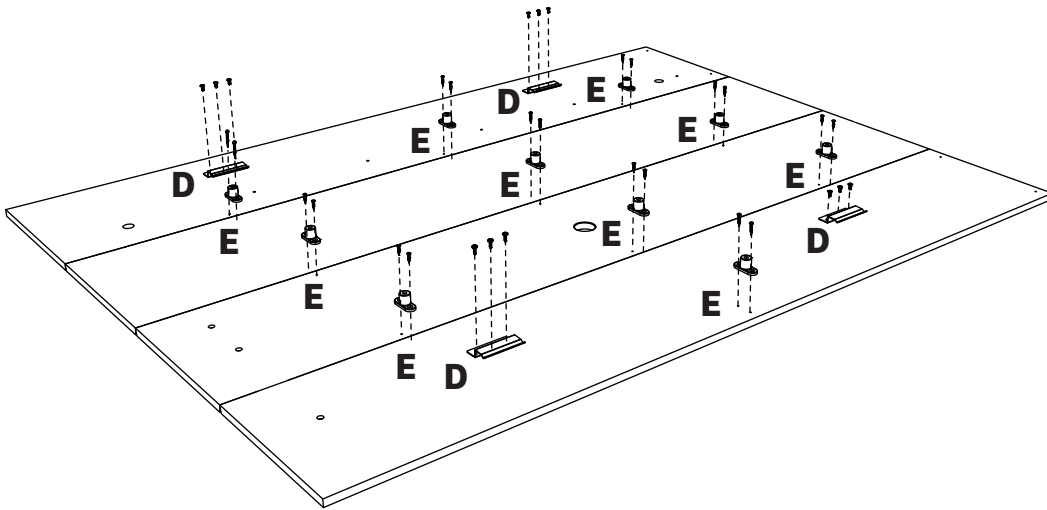

19

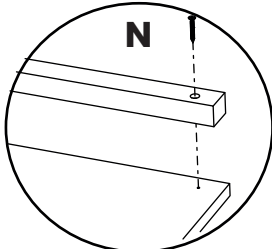



PASSO 19  
Passar cola **H** no sarrafo traseiro **17**  
Parafusar 16x**3706**

STEP 19  
Pass glue **H** on the backside batten **17**  
Screw 16x**3706**

PASO 19  
Pasar pegamento **H** en el soporte trasero **17**  
Atornillar 16x**3706**

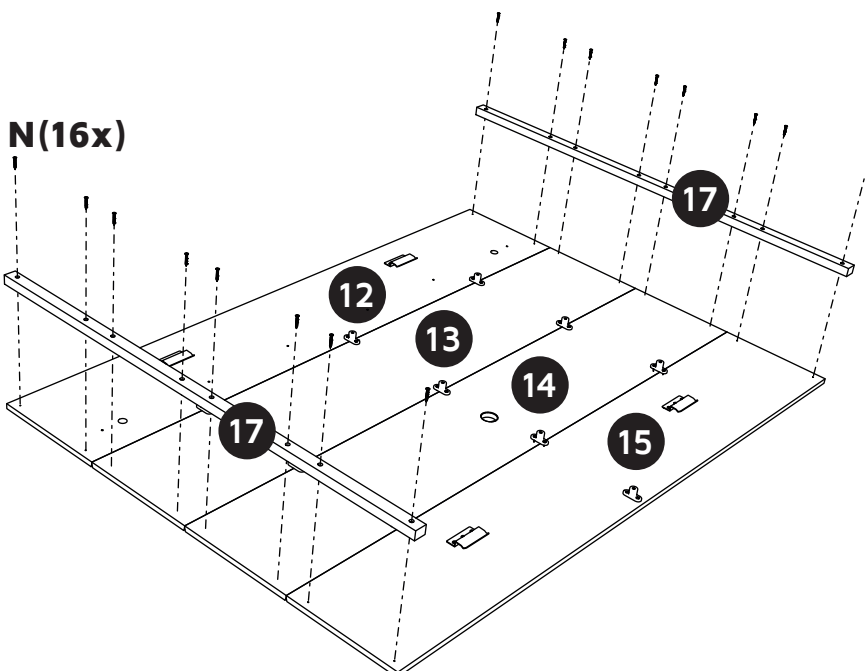
ÉTAPE 19  
Pass cole **H** et latte derrière **17**  
Vissez 16x**3706**



<b>J</b> COD. 6024	<b>F</b> 	<b>O</b> COD. 3527
-----------------------	-------------------------------------------------------------------------------------------------	-----------------------

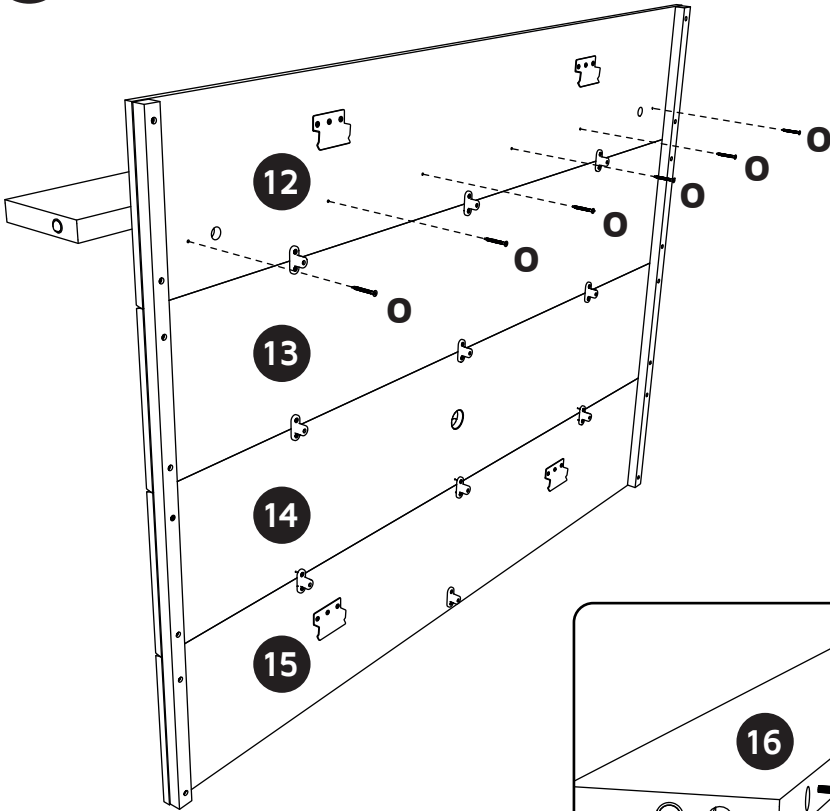

PASSO 20  
Encaixar prateleira **16**  
Parafusar 6x**3527**

STEP 20  
Attach top shelf **16**  
Screw 6x**3527**

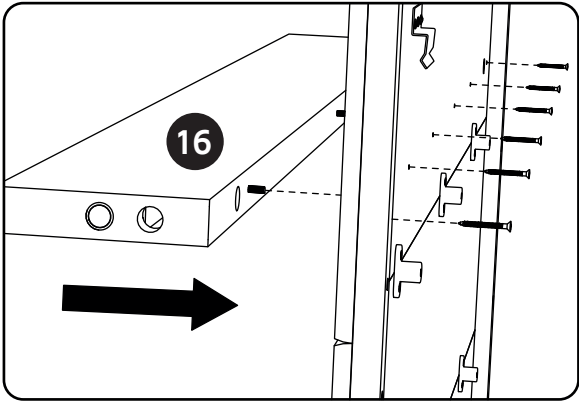

PASO 20  
Montar la estante **16**  
Atornillar 6x**3527**

ÉTAPE 20  
Insérez le étagère **16**  
Vissez 6x**3527**

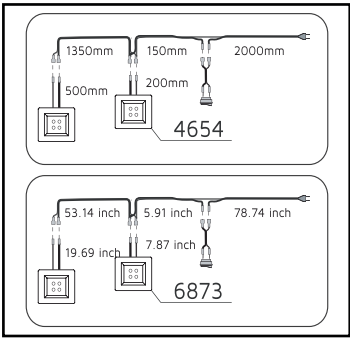
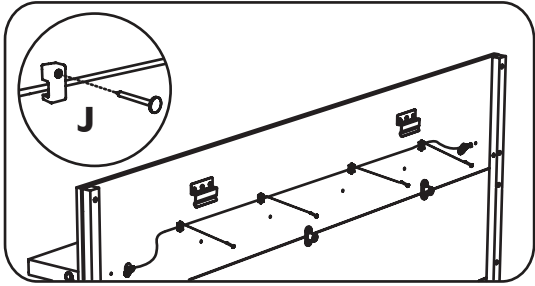
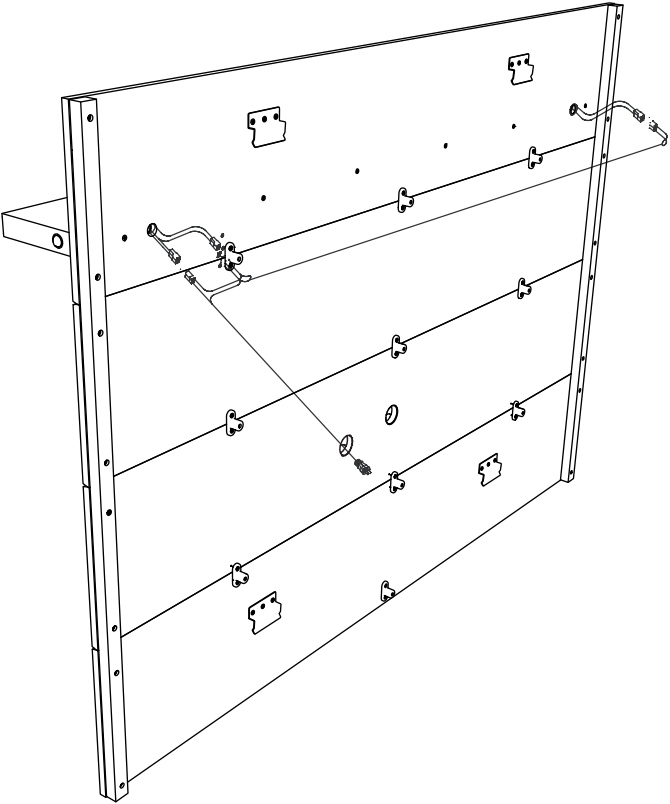

Passe os cabos.  
Pass the cables.  
Lleve el cables.  
Acheminez les câbles



<b>D</b> COD. 9070	<b>I</b> COD. 2088	<b>R</b> COD. 6244
		



**Medidas para realizar a furação da parede (em metros).**

Measurement to drill the wall. (em inches).

Medidas para realizar la perforación de la pared (en milímetros).

Mesures pour percer le mur (en millimètres).

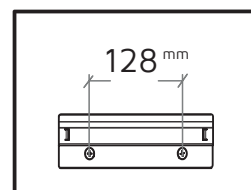
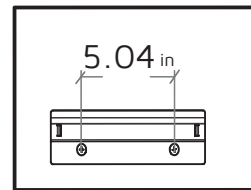

Ø8M  
Ø8MM

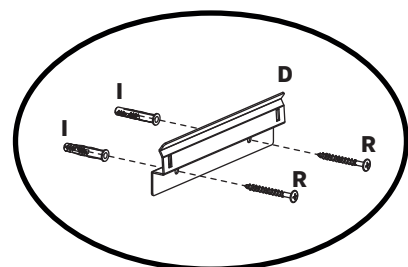
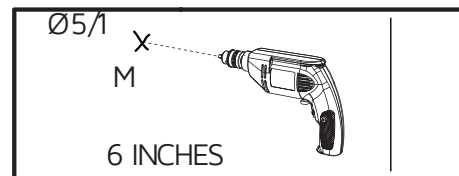

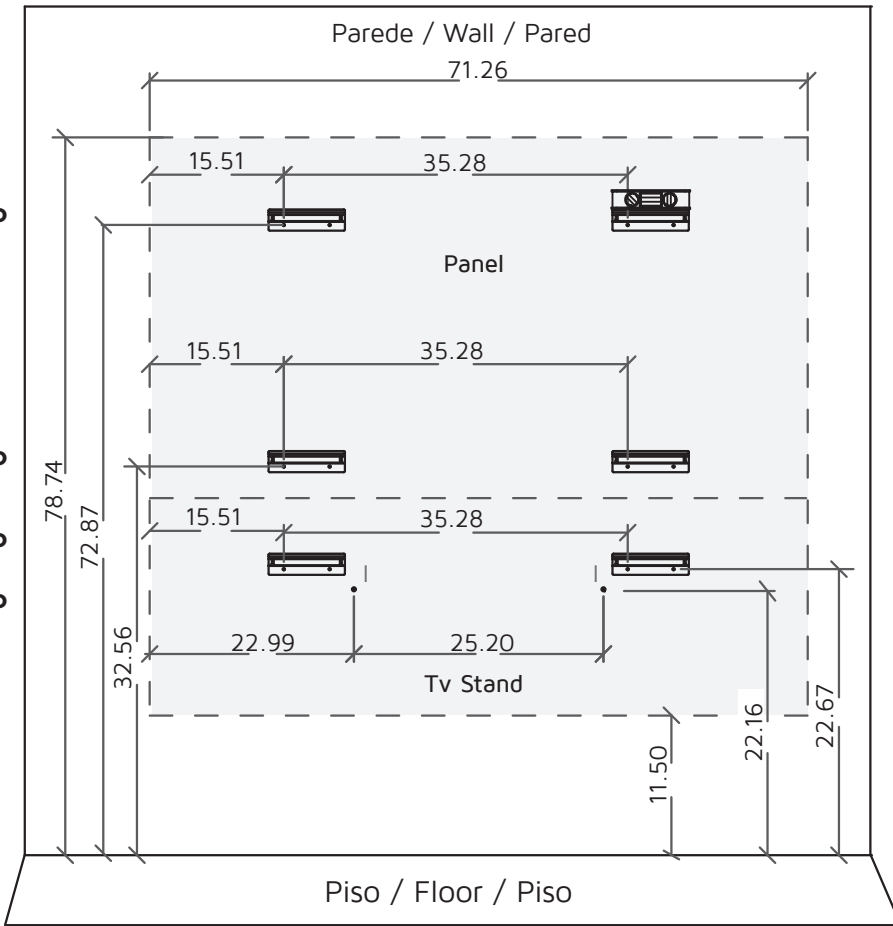

4°  
3°  
2°  
1°

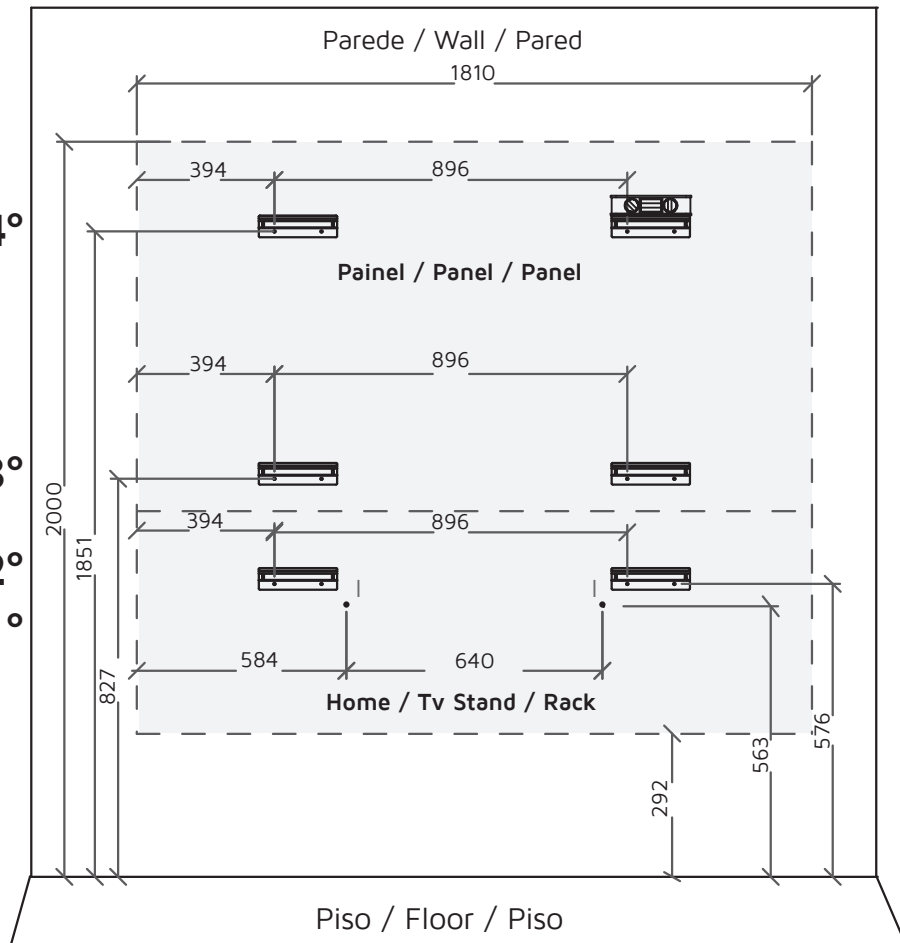

4°  
3°  
2°  
1°

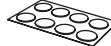

22

<b>A</b> 	<b>G</b> 	<b>S</b> COD. 4505 
-------------------------------------------------------------------------------------------------	-------------------------------------------------------------------------------------------------	--------------------------------------------------------------------------------------------------------------

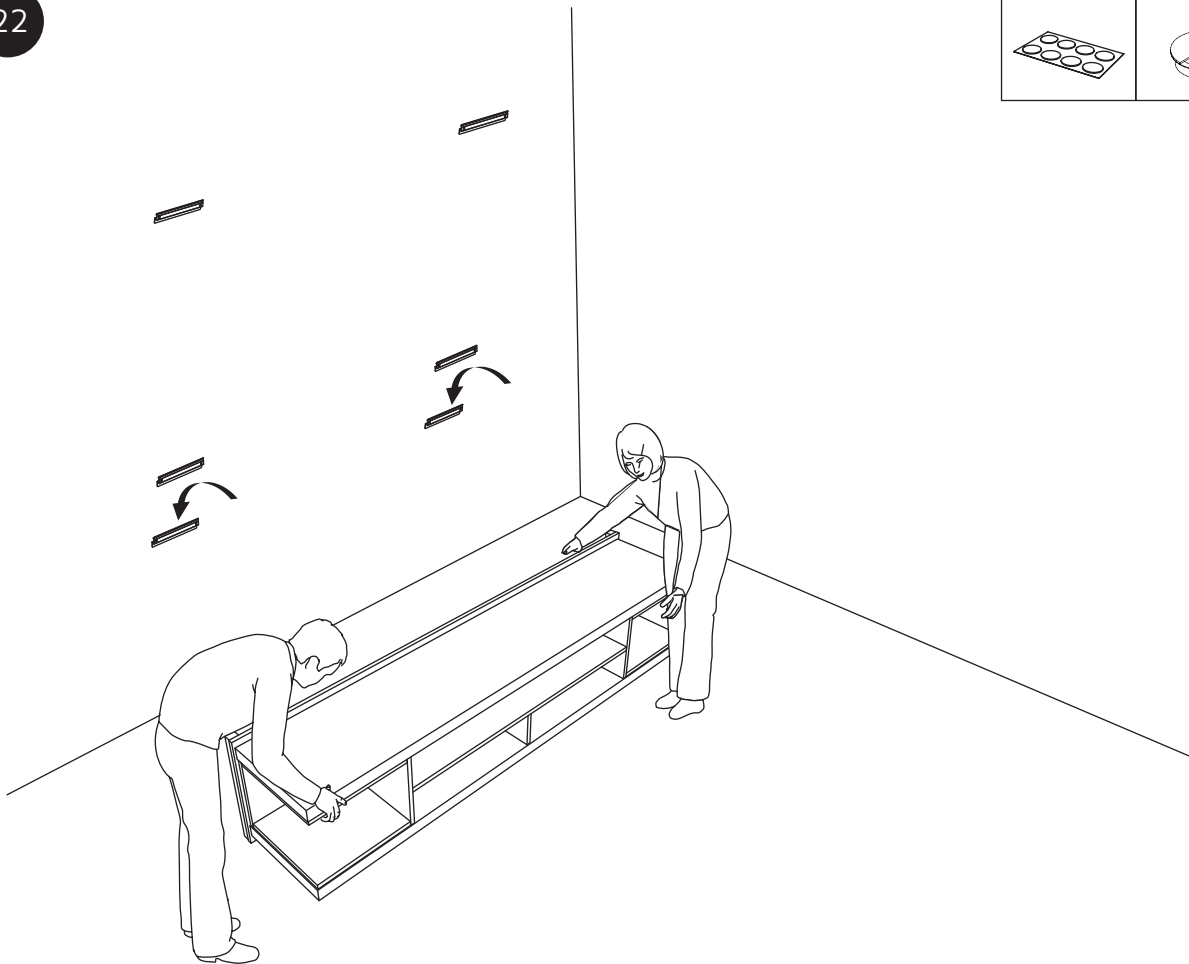

23

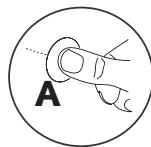

**Atenção**  
Attention  
Atención  
Attention

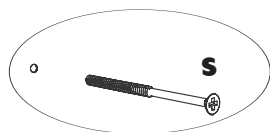
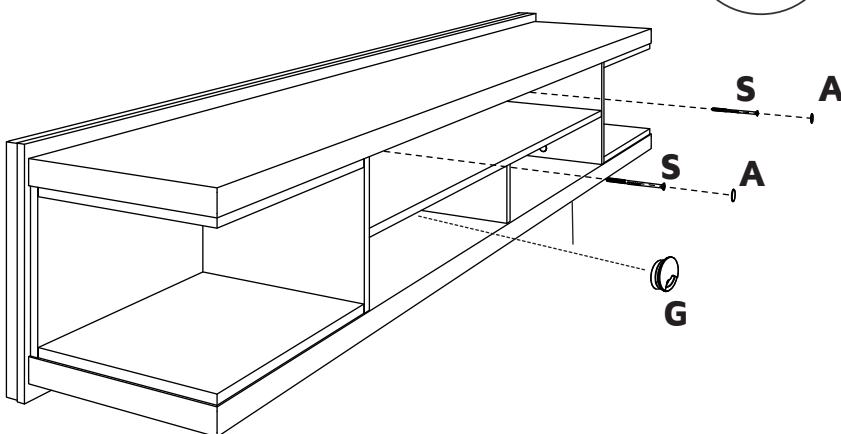

**PARAFUSO DE SEGURANÇA**  
SAFETY SCREW  
TORNILLO DE SEGURIDAD  
VIS DE SÉCURITÉ



Pass the cables through the wire channel before screwing (S)  
 Passe os cabos no canal antes de parafusar (S)  
 Lleve el cables antes atornillar (S).  
 Acheminez les câbles avant de visser (S).

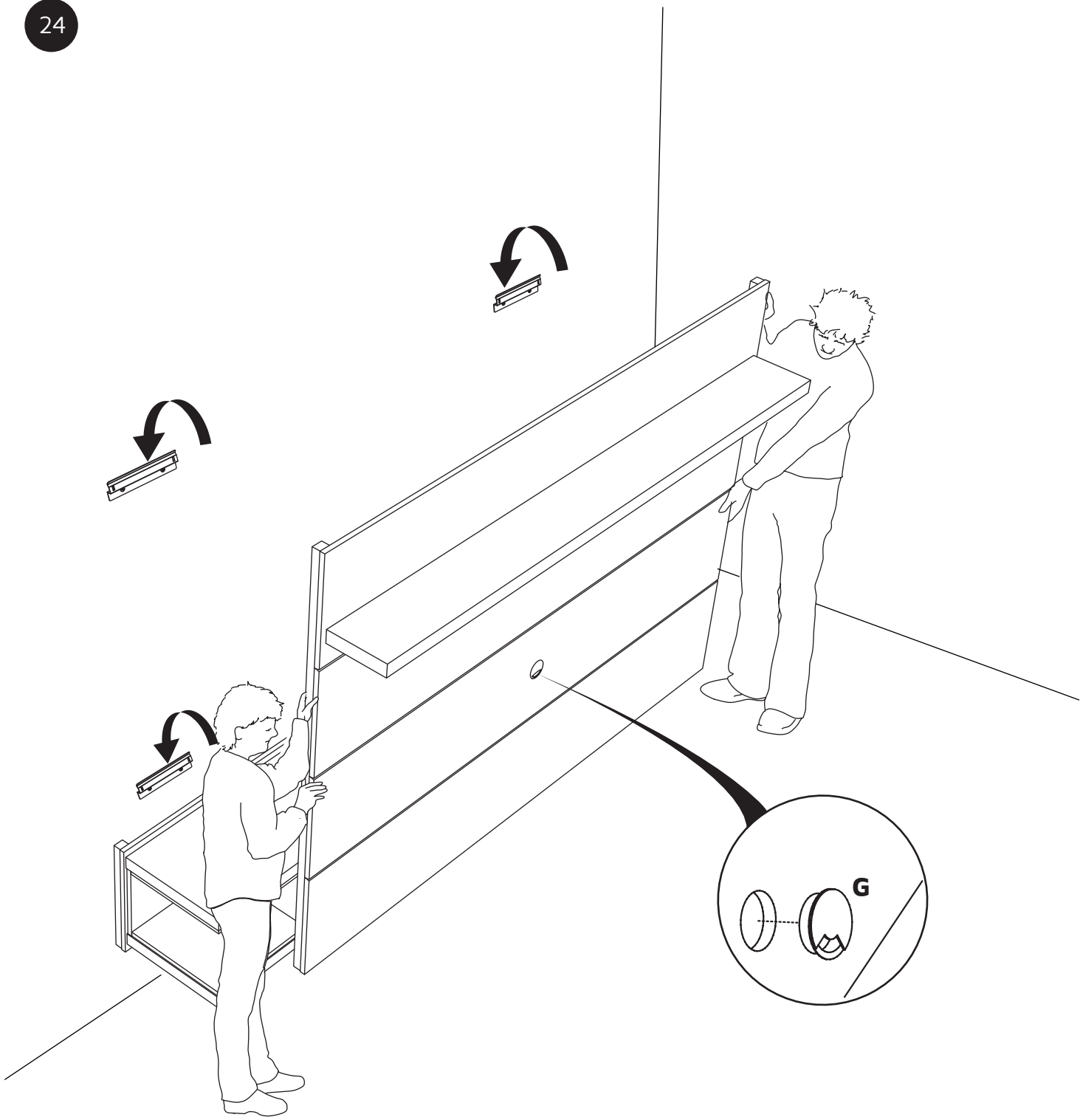

**ATENÇÃO / ATTENTION / ATENCIÓN / ATTENTION**

Passé os cabos no canal antes de parafusar (S)  
Pass the cables through the wire channel before screwing (S)  
Lleve el cables antes atornillar (S).  
Acheminez les câbles avant de visser (S).

