

# TRU Faucets

BY PREMIER COPPER PRODUCTS

## MODEL NUMBER: K-DW01ORB

- \* Description: Reverse Osmosis Cold Drinking Water Faucet
- \* Finish: Oil Rubbed Bronze
- \* Installation: Single Hole
- \* Overall Height: 8.75"
- \* Spout Reach: 4.5"
- \* Prop 65 Compliant
- \* Certifications: ASME A112.18.1/CSA B125.1, NSF/ANSI 61, California Lead Plumbing Law, ADA Compliant



\* ORB: Oil Rubbed Bronze

### Features:

- \* Solid Brass Construction
- \* Drip Free Ceramic Disc Cartridges
- \* Dispenser Type: Cold Water Faucet Only
- \* Filtration System is Not Included / Sold Separately

### Models:

- \* K-DW01ORB-G Faucet w/ D-130ORB Garbage Disposal Drain
- \* K-DW01ORB-D Faucet w/ D-132ORB Strainer Drain
- \* K-DW01ORB-DG Faucet w/ D-130ORB Disposal and D-132ORB Strainer Drains
- \* K-DW01ORB-DD Faucet w/ (2) D-132ORB Strainer Drains

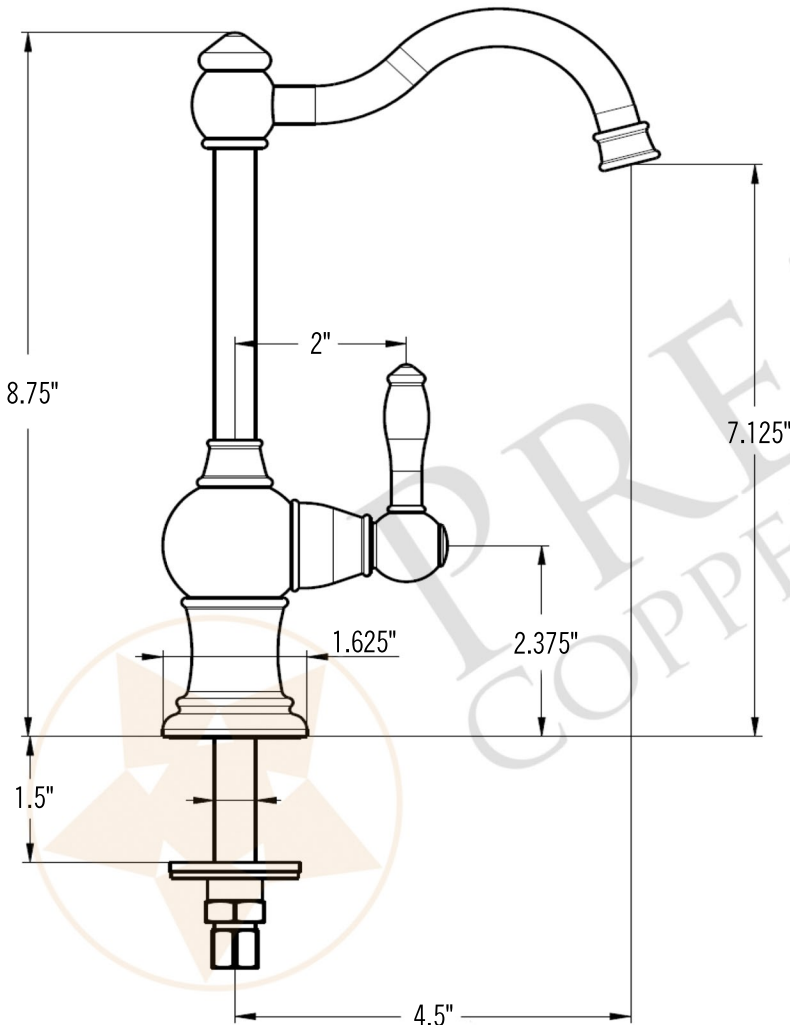

- \* Description: Reverse Osmosis Cold Drinking Water Faucet
- \* Finish: Oil Rubbed Bronze
- \* Installation: Single Hole
- \* Overall Height: 8.75"
- \* Spout Reach: 4.5"
- \* Certifications: ASME A112.18.1/CSA B125.1, NSF/ANSI 61, California Lead Plumbing Law, ADA Compliant



\* ORB: Oil Rubbed Bronze

### Exploded Parts View:

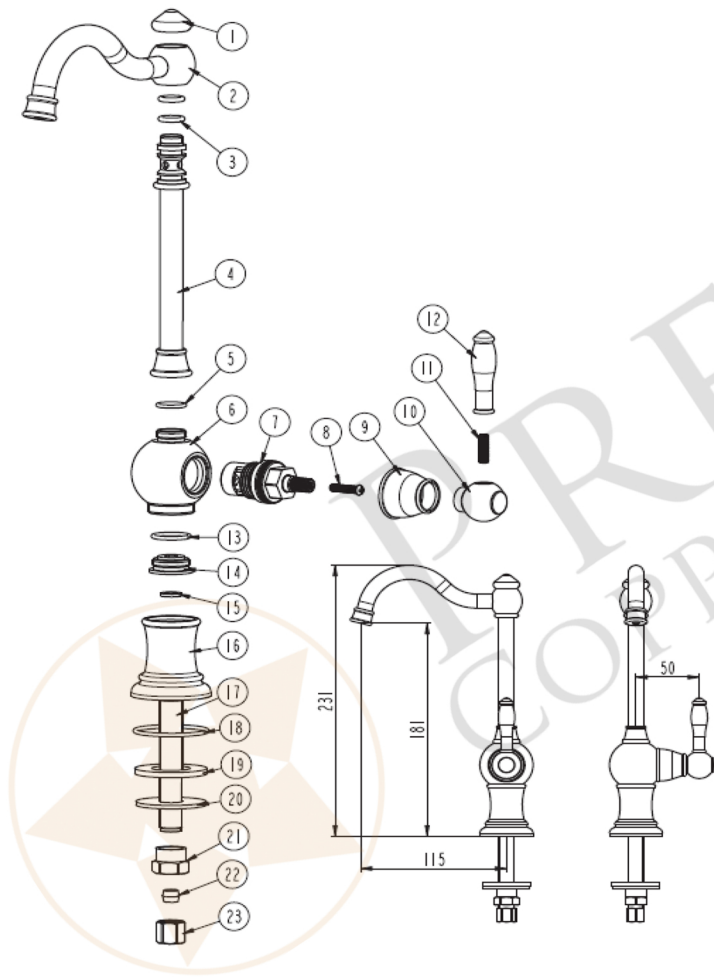

### Parts Listing:

NO.	MODEL	PART NAME
1	11012XX	SPOUT COVER
2	X14052XX	SPOUT
3	N0504600	O-RING
4	X03128XX	BODY PIPE
5	N0500500	O-RING
6	X08088XX	BODY
7	N7100718	1/4-TURN CARTRIDGE
8	902200	CROSS SCREW
9	11011XX	HANDLE COVER
10	01101XX	HANDLE ROUND NUT
11	903200	INNER HEX LOCKING SCREW
12	01100XX	HANDLE LEVER
13	N0503400	O-RING
14	X1205800	CONNECT NUT
15	N0552800	WASHER
16	16103XX	BODY CANOPY
17	X0308400	CONNECT TUBE
18	504900	O-RING
19	552400	WASHER
20	1805008	IRON GASKET
21	1201700	LOCKING NUT
22	N1805411	PLASTIC SEAL
23	1205600	LOCKING NUT