

മികവ്

പഠന സഹായി

ഹയർ സെക്കണ്ടറി

ഗണിതം



ജില്ലാ പഞ്ചായത്ത്, കാസർഗോഡ്

2013-14

മിതവ് 2014

Advisory Committee

- Chairman** : **Adv. P.P. Syamala Devi**
President, District Panchayath, Kasaragod.
- Vice Chairman** : **Smt. K. Sujatha**
Standing Committee Chairman for Education & Health,
District Panchayath, Kasaragod.
- Convenors** : **Sri. Srikrishna Kayarthaya**, DDE, Kasaragod
Dr. P.V. Krishna Kumar, Principal, DIET, Kasaragod.
Smt. Vijayalakshmi H.S, DPO, SSA, Kasaragod.
- Members** : **Sri. I. Sathyanarayana Bhat**, DEO Kasaragod.
Sri. Mohanan, DEO, Kanhangad.
Sri. K. Kamalakshan, Sr. Lecturer, DIET, Kasaragod.
- Academic Support** : **DIET Kasaragod**

ADV. P.P. SYAMALA DEVI
President
District Panchayath
Kasaragod
 Ph: 04994 - 256277
 Fax: 256277



‘Athira’
 Nelkkala Road
 Vidyanagar
 Kasaragod - 671 123
 Ph: 04994 - 220926
 04994 - 230791
 Mob: 9495653810

Date: 28.10.2013

മുഖമൊഴി

ഗുണനിലവാരമുള്ള വിദ്യാഭ്യാസം ഓരോ കുട്ടിയുടെയും അവകാശമാണ്. അത് ഉറപ്പു വരുത്തുക എന്നത് നമ്മുടെ കർത്തവ്യമാണ്. വിദ്യാർത്ഥികളുടെ പഠനനിലവാരം മികവുറ്റതാക്കുവാനുള്ള യത്നങ്ങൾ എല്ലാ സ്കൂളുകളിലും നടപ്പിലാക്കി വരുന്നത് ഏറെ സന്തോഷകരമാണ്. ഹയർ സെക്കണ്ടറി വിദ്യാർത്ഥികളുടെ പഠനനിലവാരം ഉയർത്തുവാൻ കാസറഗോഡ് ജില്ലാ പഞ്ചായത്തിന്റെ നേതൃത്വത്തിൽ നടപ്പിലാക്കിവരുന്ന മികവ് പദ്ധതി ജില്ലയിലെ ഹയർ സെക്കണ്ടറി വിജയശതമാനം ഗണ്യമായ രീതിയിൽ ഉയർത്തുവാനും ജില്ലയുടെ വിദ്യാഭ്യാസ പിന്നോക്കാവസ്ഥ ഒരു പരിധിവരെ പരിഹരിക്കുവാനും സഹായിച്ചിട്ടുണ്ട്. ഹയർ സെക്കണ്ടറി പരീക്ഷയ്ക്കുള്ള മുന്നൊരുക്ക പ്രവർത്തനങ്ങൾ എല്ലാ സ്കൂളുകളിലും നടന്നുവരുന്ന ഈ സന്ദർഭത്തിൽ കുട്ടികളിൽ ആശയങ്ങൾ കൂടുതൽ ദൃഢീകരിക്കാൻ ഉതകുന്ന, അധ്യാപകർക്ക് സഹായകമായ ഒരു കൈപുസ്തകം ‘**മികവ് 2014**’ കാസറഗോഡ് ജില്ലാ പഞ്ചായത്ത് ഈ വർഷവും പുറത്തിറക്കുകയാണ്. ചോദ്യങ്ങൾ, ചർച്ചകൾ, ചെറു ഗ്രൂപ്പ് പ്രവർത്തനങ്ങൾ തുടങ്ങിയവയിലൂടെ ഇത് സാധിക്കുമെന്നു ഞങ്ങൾ വിശ്വസിക്കുന്നു. താഴ്ന്ന നിലവാരമുള്ള കുട്ടികൾക്കും ഉയർന്ന നിലവാരമുള്ള കുട്ടികൾക്കും ഒരു പോലെ ഗുണകരമാകുന്ന വ്യത്യസ്ത നിലവാരത്തിലുള്ള പഠന പ്രവർത്തനങ്ങൾ ഇതിൽ ഉൾപ്പെടുത്താൻ ഞങ്ങൾ ശ്രദ്ധിച്ചിട്ടുണ്ട്. ഈ വർഷം ജില്ലയിലെ മുഴുവൻ കുട്ടികളെയും C+ നു മുകളിലുള്ള ഗ്രേഡുകളിലേക്ക് ഉയർത്തുക എന്ന നമ്മുടെ ലക്ഷ്യം സാക്ഷാത്കരിക്കാൻ ഇത് സഹായകമാകുമെന്ന് ഞങ്ങൾ പ്രത്യാശിക്കുന്നു. അതിനായി ജില്ലയിലെ മുഴുവൻ പ്രധാന അധ്യാപകരുടെയും, അധ്യാപകരുടെയും, കുട്ടികളുടെയും, രക്ഷിതാക്കളുടെയും നാട്ടുകാരുടെയും ആത്മാർത്ഥമായ സഹകരണവും പിന്തുണയും പ്രതീക്ഷിച്ചുകൊണ്ട്,

പ്രസിഡണ്ട്

ജില്ലാ പഞ്ചായത്ത്, കാസറഗോഡ്.

ഉള്ളടക്കം

1. ഗണിതം

5 - 153

Resource Team :

1. **Jayan T.V.**
GHSS Kakkat
2. **A. Vidya**
GHSS Udma
3. **V. Pavithran**
GHSS Udinoor

HIGHER SECONDARY

MATHEMATICS

1. RELATIONS AND FUNCTIONS

Previous Knowledge

Cartesian Product

1. A, B ഇവ ശൂന്യഗണങ്ങളല്ലായെങ്കിൽ A യിലെ ഓരോ അംഗവും ആദ്യസംഖ്യയായും B യിലെ ഓരോ അംഗവും രണ്ടാമത്തെ സംഖ്യയായും വരുന്ന ക്രമജോടികളുടെ ഗണമാണ് A ക്രോസ്സ് B. ഇതിനെ $A \times B$ എന്ന് സൂചിപ്പിക്കുന്നു.

example: $A = (1,2)$ $B = (3,4)$ എങ്കിൽ $A \times B = \{(1,3), (1,4), (2,3), (2,4)\}$.

2. Relation (ബന്ധം)

A എന്ന ഗണത്തിൽ നിന്ന് B എന്ന ഗണത്തിലേക്കുള്ള relation എല്ലായ്പ്പോഴും $A \times B$ യുടെ ഉപഗണം (subset) ആയിരിക്കും. A യിൽ നിന്ന് B യിലേക്കുള്ള relation നിലെ അംഗങ്ങൾ എല്ലായ്പ്പോഴും ക്രമജോടികളായിരിക്കും.

3. Domain

A യിൽ നിന്ന് B യിലേക്കുള്ള ഒരു relation ലെ ക്രമജോടികളുടെ ആദ്യഅംഗങ്ങളുടെ ഗണത്തെ റിലേഷന്റെ മണ്ഡലം (domain) എന്നു പറയുന്നു. ക്രമജോടിയിലെ രണ്ടാമത്തെ അംഗങ്ങളുടെ ഗണത്തെ Range of a relation എന്നും വിളിക്കുന്നു.

4. Functions

A യിൽ നിന്ന് B യിലേക്കുള്ള റിലേഷൻ function ആകണമെങ്കിൽ A യിലെ എല്ലാ അംഗങ്ങൾക്കും ഒരേ ഒരു image (പ്രതിബിംബം) B യിൽ ഉണ്ടായിരിക്കണം.

വ്യത്യസ്ത രീതിയിലുള്ള ബന്ധങ്ങൾ

Reflexive relations

A relation R on A is a reflexive If $aRa, \forall a \in A$ or $(a,a) \in R, \forall a \in A$ i.e, A യിലെ എല്ലാ അംഗങ്ങൾക്കും അതേ അംഗം ഇമേജ് ആയിവരുന്ന ക്രമജോടികൾ R - ൽ ഉണ്ടായിരിക്കണം.

Symmetric Relation

A relation R on A is said to be symmetric if $(a,b) \in R \Rightarrow (b,a) \in R$ അതായത് തന്നിട്ടുള്ള R എന്ന ബന്ധത്തിൽ (a,b) എന്ന ക്രമജോടി R ൽ ഉണ്ടെങ്കിൽ (b,a) എന്ന ക്രമജോടി R ൽ നിർബന്ധമായും ഉണ്ടായാൽ മാത്രമേ R ഒരു symmetric relation ആണെന്ന് പറയുകയുള്ളൂ.

ഉദാ:- Let $A = \{1, 2, 3, 4\}$

Define $R = \{(1, 1), (2, 2), (3, 3), (1, 4), (4, 4), (4, 1), (2, 3)\}$

Here R is a reflexive relation and symmetric relation. Because $(a,a) \in R, \forall a \in R$ and $(1,4) \in R, (4, 1) \in R ; (2, 3) \in R ; (3, 2) \in R$

Eg:- $A = \{1, 2, 3, 4\}$, A relation on R is defined as $R = \{(1,1), (3,2), (4,3), (4,4), (2,3), 3,4)\}$

Ans: തന്നിട്ടുള്ള ബന്ധം ഒരു reflexive relation അല്ല കാരണം $(2,2) \notin R$ പക്ഷെ R Symmetric relation ആണ്. കാരണം $(3,2) \in R, (2,3) \in R, (4,3) \in R, (3,4) \in R$.

Transitive Relation

A relation is transitive if $(a,b) \in R, (b,c) \in R \Rightarrow (a,c) \in R$

ഒരു ബന്ധം R Transitive relation ആണെന്ന് പറയണമെങ്കിൽ $(a,b), (b,c)$ എന്നിവ R ലെ അംഗങ്ങളായാൽ (a,c) R-ലെ ഒരു അംഗമായിരിക്കണം.

ഉദാ: Z (പൂർണ്ണസംഖ്യാഗണം) എന്ന ഗണത്തിലെ ഒരു ബന്ധമാണ് താഴെ കൊടുത്തിട്ടുള്ളത്.

$R = \{(a,b)/a-b \text{ 2 ന്റെ ഗുണിതമാണ്}, a, b, \in Z\}$

Ans: ഇവിടെ ഒരു ക്രമജോടി R-ലെ അംഗമാകണമെങ്കിൽ $(b-a) \text{ 2 ന്റെ ഗുണിതമായിരിക്കണം.}$

$(a,b), (b,c), \in R \Rightarrow b-a, c-b$ ഇവ 2 ന്റെ ഗുണിതമാണ്. $(a - b) = m(2) \text{ (2 ന്റെ ഗുണിതം)}$

$\Rightarrow b-a+c-b$ 2 ന്റെ ഗുണിതമാണ്. $\Rightarrow (b - a) = M(2) \text{ thus R is symmetric.}$

$\Rightarrow c-a, 2$ ന്റെ ഗുണിതമാണ്.

$\Rightarrow (a,c) \in R, \forall a,b,c \in R$

അതുകൊണ്ട് R - ഒരു transitive relation ആണ്.

Equivalence Relation

A എന്ന ഗണത്തിൽ നിർവചിക്കപ്പെട്ടിട്ടുള്ള ഒരു ബന്ധം R (ie, $R:A \rightarrow A$) Equivalence relation ആകണമെങ്കിൽ,

1. R - Reflexive ആയിരിക്കണം. ie, $(a,a) \in R, \forall a \in A$
2. R - Symmetric ആയിരിക്കണം. ie, $(a,b) \in R \Rightarrow (b,a) \in R$
3. ie, $(a,b) (b,c) \in R \Rightarrow (a,c) \in R$ (transitive ആയിരിക്കണം)

ഉദാഹരണം

Z എന്ന ഗണത്തിൽ നിർവചിക്കപ്പെട്ടിട്ടുള്ള ഒരു ബന്ധമാണ് (relation)

$$R = \{a, b\} : b-a, 2 \text{ ന്റെ ഒരു ഗുണിതമാണ് } a, b \in Z\}$$

ഇവിടെ R ഒരു equivalence relation ആണ്. എന്തുകൊണ്ടെന്നാൽ

1. R - Reflexive ആണ്.

$$\text{Let } a \in R, a-a = 0 \Rightarrow a-a = 0 = ax0 \Rightarrow a-a = 0$$

0, 2 ന്റെ ഒരു ഗുണിതമാണ്

$$\therefore (a,a) \in R, \forall a \in R$$

2. R - Symmetric ആണ്.

കാരണം,

$$(a,b) \in R \Rightarrow 2 \text{ ന്റെ ഗുണിതമാണ് } b-a$$

$$\Rightarrow 2 \text{ ന്റെ ഗുണിതമാണ് } a-b$$

$$\Rightarrow (b,a) \in R$$

3. R ഒരു transitive relation ആണ്.

For,

(a,b), (b,c) ഇവ R ലെ അംഗങ്ങളാണെന്നിരിക്കട്ടെ.

$$\therefore b-a, c-b \text{ ഇവ } 2 \text{ ന്റെ ഗുണിതങ്ങളാണ്.}$$

$$\therefore b-a+c-b \text{ ഇവ } 2 \text{ ന്റെ ഒരു ഗുണിതമാണ്.}$$

അതായത് c-a 2 ന്റെ ഒരു ഗുണിതമാണ്.

$$\therefore (a,c) \in R$$

വ്യത്യസ്തരീതിയിലുള്ള ഏകദങ്ങൾ (Types of Functions)

1. One-one or injective function

A എന്ന ഗണത്തിൽ (സെറ്റ്) നിന്ന് B എന്ന ഗണത്തിലേക്കുള്ള ഒരു ഏകദം (function) one one ആകണമെങ്കിൽ A യിലെ എല്ലാ വ്യത്യസ്ത അംഗങ്ങൾക്കും B യിൽ വ്യത്യസ്ത പ്രതിബിംബം (ഇമേജ്) ഉണ്ടായിരിക്കണം. അതായത് A യിലെ രണ്ട് അംഗങ്ങൾക്ക് ഒരേ ഇമേജ് ആണുള്ളതെങ്കിൽ ആ രണ്ട് അംഗങ്ങളും തുല്യമായാൽ മാത്രമേ ഏകദം ഒരു one one ആകുകയുള്ളൂ.

$$\text{അതായത് } f(x_1) = f(x_2) \Rightarrow x_1 = x_2, \forall x_1, x_2 \in A$$

ഉദാ:-

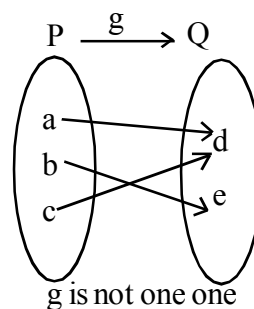
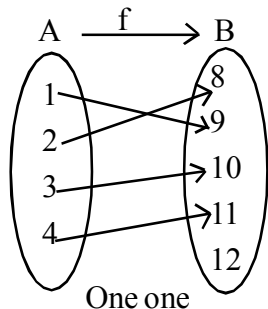

Onto Function (Surjective function)

A യിൽ നിന്ന് B യിലേക്കുള്ള 'f' എന്ന ഏകദം ഒരു onto function ആകണമെങ്കിൽ Bയിലെ എല്ലാ അംഗങ്ങൾക്കും A യിൽ പ്രി-ഇമേജ് ഉണ്ടായിരിക്കണം.

ie, $f: A \rightarrow B$ ഒരു onto function ആയാൽ Bയിലെ ഏത് അംഗം പരിഗണിച്ചാലും ആ അംഗങ്ങൾക്കെല്ലാം A യിൽ ഒരു അംഗം ഉണ്ടായിരിക്കണം.

ie, $\forall y \in B$, we can find an element

$$x \in A \text{ such that } f(x) = y$$

Note: $f: A \rightarrow B$ ഒരു onto function ആണെങ്കിൽ $f(x) = y$, (ie $R(A)=B$ ആയിരിക്കും).

ഉദാഹരണം:

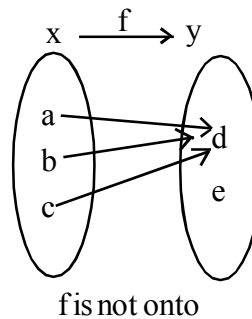
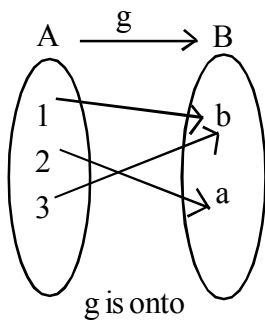

Bijjective Function

A എന്ന ഗണത്തിൽനിന്ന് B എന്ന ഗണത്തിലേക്കുള്ള f എന്ന function bijjective ആകണമെങ്കിൽ f one one ഉം onto ഉം ആയിരിക്കണം.

A one one and onto function is bijjective.

ഉദാ:-

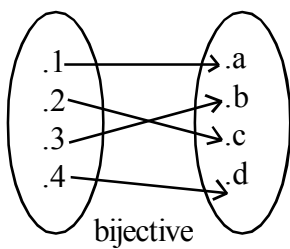

A എന്ന ഗണത്തിൽ നിന്ന് B എന്ന ഗണത്തിലേക്കുള്ള ഒരു function bijjective ആയാൽ $n(A)=n(B)$ ആയിരിക്കും.

Composition Function

Let $f: A \rightarrow B$ and $g: B \rightarrow C$ be two functions. Then the composition of 'f' and 'g' denoted by $g \circ f$ is defined as the function $g \circ f: A \rightarrow C$ given by $(g \circ f)(x) = g(f(x)), \forall x \in A$

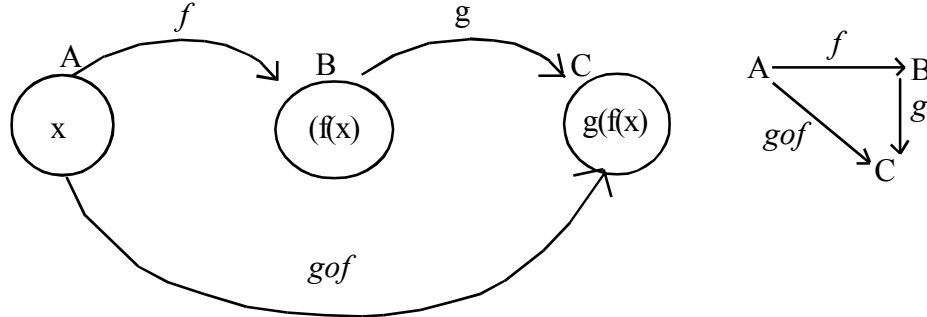

Eg:- Let $A = \{2, 3, 4, 5\}$, $B = \{3, 4, 5, 9\}$
 and $C = \{7, 11, 15\}$, $f: A \rightarrow B$, $g: B \rightarrow C$ defined as $f(2)=3, f(3)=4, f(4)=f(5)=5$ and $g(3) = g(4) = 7$ and $g(5) = g(9) = 11$

Find $g \circ f$

Clearly from the figure

$$g \circ f = \{(2,7), (3,7), (4,11), (5,11)\}$$

OR

Domain of $g \circ f = A$

Range of $g \circ f = C$

$$(g \circ f)(2) = g(f(2)) = g(3) = 7$$

$$(g \circ f)(3) = g(f(3)) = g(4) = 7$$

$$(g \circ f)(4) = g(f(4)) = g(5) = 11$$

$$(g \circ f)(5) = g(f(5)) = g(5) = 11$$

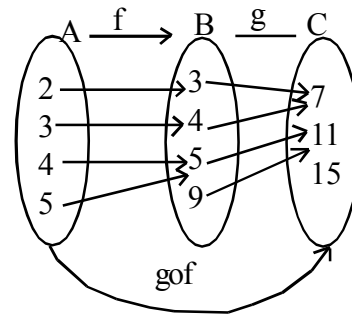

Identity Function

An identity function I on A is a function from $A \rightarrow A$ defined as $I(x) = x, \forall x \in A$

Inverse of a Function

X എന്ന ഗണത്തിൽ നിന്ന് Y എന്ന ഗണത്തിലേക്കുള്ള ഒരു function ആണ് 'f'. $g \circ f = I_x, f \circ g = I_y$ എന്ന വ്യവസ്ഥകൾ പാലിക്കത്തക്കവിധത്തിൽ Y യിൽ നിന്ന് X യിലേക്ക് ഒരു function കണ്ടുപിടിക്കാൻ സാധിക്കുന്നുണ്ടെങ്കിൽ g എന്ന function നെ f എന്ന function ന്റെ inverse എന്നു പറയുന്നു. ഇവിടെ I_x എന്നത് $X \rightarrow X$ ലേക്കുള്ള function ആണ്. കൂടാതെ $I_x(x) = x, \forall x \in X$ അതായത് I_x എന്നത് X ലെ ഒരു ഐഡൻറിറ്റി ഫങ്ഷൻ ആണ്. അതുപോലെ I_y എന്നത് $y \rightarrow y$ യിലേക്കുള്ള ഫങ്ഷൻ കൂടാതെ $I(y) = y, \forall y \in y$ എന്ന ഫങ്ഷൻ inverse ഉണ്ടെങ്കിൽ f

invertible ആണെന്ന് പറയുന്നു. f ന്റെ inverse നെ f^{-1} എന്നെഴുതി സൂചിപ്പിക്കുന്നു.

Note: f എന്ന ഫങ്ഷൻ invertible ആണെങ്കിൽ f - bijective ആയിരിക്കും. f എന്ന ഫങ്ഷൻ bijective (one - one and onto) ആണെങ്കിൽ f ന് നിർബന്ധമായും inverse ഉണ്ടായിരിക്കും.
ie, f is invertible $\Leftrightarrow f$ is bijective.

ഉദാഹരണം

$f: X \rightarrow Y$ എങ്കിൽ $f^{-1}: Y \rightarrow X$ ആയിരിക്കും

$S = \{1, 2, 3\}$ f എന്നത് S ൽ നിന്ന് S ലേക്കുള്ള ഒരു ഫങ്ഷൻ ആണ്. താഴെകൊടുത്തിരിക്കുന്ന ഫങ്ഷൻസിന് inverse ഉണ്ടോ എന്ന് പരിശോധിക്കുക. ഉണ്ടെങ്കിൽ f^{-1} കാണുക.

a) $f = \{(1, 1), (2, 2), (3, 3)\}$

ഇവിടെ f bijective function ആണ്. കാരണം f ലെ വ്യത്യസ്ത അംഗങ്ങൾക്ക് വ്യത്യസ്ത ഇമേജ് ആണുള്ളത്. കൂടാതെ S - ലെ എല്ലാ അംഗങ്ങൾക്കും pre-image ഉണ്ട്. അതുകൊണ്ട് f invertible ആണ്.

$$f^{-1} = \{(1,1), (2,2), (3,3)\}$$

Note: ഇവിടെ 'f' ഒരു identity function ആണ്. Identity function ന്റെ inverse അതേ function തന്നെ ആയിരിക്കും.

b) $f = \{(1,2), (2,1), (3,1)\}$

ഇവിടെ $f(2) = 1 = f(3)$. അതുകൊണ്ട് f one one function അല്ല. f ന് inverse ഇല്ല.

c) $f = \{(1,3), (3,2), (2,1)\}$

ഇവിടെ 'f' one-one and onto ആണ്. (എന്തുകൊണ്ട്?) f ന് inverse ഉണ്ട്.

$$f^{-1} = \{(3,1), (2,3), (1,2)\}$$

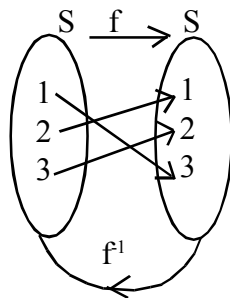

Review Questions

താഴെകൊടുത്തിരിക്കുന്ന functions ന് inverse ഉണ്ടോ എന്ന് പരിശോധിക്കുക. കാരണം എഴുതുക.

1. $f: \{1, 2, 3, 4\} \rightarrow \{10\}$
 $f: \{(1,10), (2,10), (3,10), (4,10)\}$

2. $g : \{5, 6, 7, 8\} \rightarrow \{1, 2, 3, 4\}$
 $g = \{(5, 4), (6, 3), (7, 4), (8, 2)\}$
3. $h : \{2, 3, 4, 5\} \rightarrow \{7, 9, 11, 13\}$
 $h = \{(2, 7), (3, 9), (4, 11), (5, 13)\}$

Inverse of a Function

A function $f : x \rightarrow y$ has inverse 'g' if $g : y \rightarrow X$ and $(g \circ f)(x) = x, \forall x \in X$ and

$(f \circ g)(y) = y, \forall y \in Y$. Then we write $f^{-1} = g$.

'f' is invertible \Leftrightarrow It is one one and onto...

Example :

- 1 Let $Y = \{n^2 \mid n \in N\}$. Consider $f : N \rightarrow Y$ such that $f(n) = n^2$, show that f is invertible. Find the inverse of 'f'.

Ans: Given $Y = \{n^2 \mid n \in N\}$ and $f : N \rightarrow Y$

First we want to define a function from $Y \rightarrow N$

Get $y \in Y$. Then $y = n^2, n \in N, \therefore n = \sqrt{y}$

Define $g : y \rightarrow N$ by $g(y) = \sqrt{y}, y \in Y$

$$(g \circ f)(n) = g(f(n)) = g(n^2)$$

$$= \sqrt{n^2} = n$$

Let, $y \in Y$

$$(f \circ g)(y) = f(g(y))$$

$$= f(\sqrt{y})$$

$$= (\sqrt{y})^2$$

$$= y$$

$\therefore g$ is the inverse of f .

ie, $f^{-1} = g$

State with reason whether the following function have inverse.

- 1) $f : \{1, 2, 3, 4\} \rightarrow \{1, 0\}$ with

$$f = \{(1, 10), (2, 10), (3, 10), (4, 10)\}$$

- 2) $g : \{5, 6, 7, 8\} \rightarrow \{1, 2, 3, 4\}$ with

$$g = \{(5, 4), (6, 3), (7, 4), (8, 2)\}$$

- 3) $h : \{2, 3, 4, 5\} \rightarrow \{7, 9, 11, 13\}$ with

$$h = \{(2, 7), (3, 9), (4, 1), (5, 13)\}$$

Answers

- 1) f is not one-one because different elements, 1, 2, 3, 4 have same image 10
 $\therefore f$ has no inverse
- 2) The $g : \{5, 6, 7, 8\} \rightarrow \{1, 2, 3, 4\}$
Hence 1 in the co-domain of g has no preimage, $\therefore g$ is not onto
Hence g has no inverse.
- 3) h is one-one and onto
 $\therefore h$ has inverse
 $h^{-1} = \{(7, 2), (9, 3), (1, 4), (13, 5)\}$

Miscellaneous Examples

1. Let $A = \mathbb{N} \times \mathbb{N}$ and $*$ be a binary operation on A defined by
 $(a, b) * (c, d) = (a+c, b+d)$
 - a) Show that $*$ is commutative and Associative.
 - b) Find the identify element for $*$ on A , if any.

Answer :

- a) Given $A = \mathbb{N} \times \mathbb{N}$
Any element in A is of the form (a, b) , $a, b \in \mathbb{N}$
We want to S.T. ' $*$ ' is commutaitve
ie, $x*y = y*x, \forall x, y \in A$
Let $x, y \in A$ (Then $x = (a, b), y = (c, d)$)
 $= x*y = (a, b) * (c, d)$
 $= (a+c, b+d)$ by definition
 $= (c+a, d+b)$, Since $+$ is commutaitve on \mathbb{N} .
 $= (c, d) + (a, b)$, by definition of $*$
 $= y*x$
 $\therefore *$ is commutative on A .
Now to Prove that $*$ is associative.
Let $x, y, z \in A$. Then
 $x = (a, b), y = (c, d)$
 $z = (u, v)$
ie, to Show that $(x * y) * z = x * (y * z)$
 $x * y = (a, b) * (c, d)$
 $= (a + c, b + d)$
 $(x * y) * z = (a + c, b + d) * (u, v)$

$$= ((a+c)+u, (b+d)+v) \text{ by definition}$$

$$= (a+c+u, b+d+v) \text{ (since + is associative with } \mathbb{N} \dots \dots \dots (1)$$

Now $y * z = (c, d) * (u, v)$
 $= (c+u, d+v)$

$$x * (y * z) = (a, b) * (c+u, d+v)$$

$$= (a+(c+n), b+(d+v))$$

$$= (a+c+n, b+d+v) \dots \dots \dots (2)$$

From (1) and (2) * is associative.

b) Let $e = (p, q)$ be the identity element in A .

Then $x * e = x$

$$(a, b) * (p, q) = (a, b)$$

$$(a+p, b+q) = (a, b)$$

$$\Rightarrow a+p = a \text{ and } b+q = b$$

$$\Rightarrow p = 0 \text{ and } q = 0$$

But $(p, q) = (0, 0) \notin \mathbb{N} \times \mathbb{N} = A$

\therefore has no identity element for *.

2. Consider the binary operation $*: \mathbb{R} \times \mathbb{R} \rightarrow \mathbb{R}$ and $0: \mathbb{R} \times \mathbb{R} \rightarrow \mathbb{R}$ defined by

$$a * b = |a - b| \text{ and } a \circ b = a, \forall a, b \in \mathbb{R}$$

- Show that * is commutative
- Is '*' associative. Justify your answer.
- Show that '0' is associative but not commutative.
- Show that $a * (b \circ c) = (a * b) \circ (a * c), \forall a, b, c \in \mathbb{R}$

Solution

a) Let $a, b \in \mathbb{R}$

$$a * b = |a - b|$$

$$= b * a$$

\therefore '*' is commutative

b) we have $1, 2, 3 \in \mathbb{R}$

$$1 * 2 = |1 - 2| = 1$$

$$(1 * 2) * 3 = 1 * 3$$

$$= |1 - 3| = 2$$

$$2 * 3 = |2 - 3| = 1$$

$$1 * (2 * 3) = 1 * 1$$

$= |1 - 1| = 0$
 $\therefore (1 * 2) * 3 \neq 1 * (2 * 3)$
 $\therefore *$ is not associative.

c) To Show that 0 is associative
 ie, to Show that $(aob) oc = ao (boc)$
 If $a, b, c \in \mathbb{R}$
 Then $aob = a$
 $(aob) 0c = aoc$
 $= a \dots\dots\dots(1)$

we have $(boc) = b$
 $ao (boc) = aob$
 $= a \dots\dots\dots(2)$

Then (1) and (2) $(aob)oc = ao(boc)$
 $\therefore '0'$ is associative.

To Show that '0' is not commutative.
 We have $1, 2 \in \mathbb{R}$. Then $102 = 1$ by definition.
 $201 = 2$
 $\therefore 102 \neq 201$
 $\therefore 0$ is not commutative.

Binary Operation

ഏത് രണ്ട് എണ്ണൽസംഖ്യകളുടെ തുക ഒരു എണ്ണൽ സംഖ്യ ആയിരിക്കും.
 അതായത് $a+b \in \mathbb{N}, \forall a, b \in \mathbb{N}$.

ഏത് രണ്ട് പൂർണ്ണസംഖ്യകളുടെയും ഗുണഫലം ഒരു പൂർണ്ണസംഖ്യ ആയിരിക്കും.
 അതായത് $a \times b \in \mathbb{Z}$, for every $a, b, \in \mathbb{Z}$ ഇവിടെ "+" എന്ന ഓപ്പറേഷനെ * എന്ന് മാറ്റി എഴുതിയാൽ $a*b \in \mathbb{N}, \forall a, b \in \mathbb{N}$ ഇവിടെ * എന്ന ഓപ്പറേഷനെ N എന്ന ഗണത്തിലെ binary operation എന്നുപറയുന്നു.

Definition

* എന്ന operation A ഗണത്തിലെ binary operation ആകണമെങ്കിൽ
 * $A \times A$ നിന്ന് A യിലേക്കുള്ള ഒരു ഫങ്ഷൻ ആയിരിക്കണം.
 ഉദാ: ഗുണനം (multiplication) Z എന്ന ഗണത്തിലെ ഒരു binary operation ആണ്.
 $a \times b \in \mathbb{Z}, \forall a, b \in \mathbb{Z}$

Subtraction N-ലെ ഒരു Binary operation അല്ല. കാരണം $a \div b$ ഒരു natural number ആയിരിക്കണം എന്നില്ല.

[if $a = 2, b = 3, \frac{a}{b} = \frac{2}{3} \notin Z$]

Example

$A = \{-1, 0, 1\}$ സാധാരണ ഗുണനം A യിൽ binary operation ആണ്.

ഇവിടെ composition table ലെ എല്ലാ അംഗങ്ങളും

A എന്ന ഗണത്തിലെ അംഗങ്ങളാണ്.

x	-1	0	1
-1	1	0	-1
0	0		0
1	-1	0	1

Usual addition A യിലെ Binary operation അല്ല.

ഇവിടെ $-1+1 = -2 \notin A$

+	-1	0	1
-1	-2	-1	0
0	-1	0	1
1	0	1	2

അതുകൊണ്ട് '+' A യിലെ ഒരു binary operation അല്ല.

Commutative property

A എന്ന ഗണത്തിലെ $*$ എന്ന binary operation commutative ആകണമെങ്കിൽ $a*b = b*a, \forall a, b \in A$ ആയിരിക്കും.

Usual addition "+" is commutative on Z ie, $a+b = b+a, \forall a, b \in Z$

Example: Define an operation $*$ on R defined by $a*b = \frac{ab}{4}, a, b \in R$

- a) Is $*$ a binary operation on R . Justify?
- b) Prove that $*$ is commutative.

Ans: a) $a*b = \frac{ab}{4} \in R, \forall a, b$

$\therefore *$ is a Binary operation on R

b) $a*b = \frac{ab}{4},$

$= \frac{ba}{4}$ (multiplication is commutative on R)

$= b*a$

$\therefore a*b = b*a$, ie, $*$ is commutative.

Example 2

Define an operation * on Z as $a*b = a+b - ab$

- 1) Is * a Binary operation on Z
- 2) Prove that * is commutative.

Ans: 1) Given $a*b = a+b - 2b \in Z, \forall a, b \in Z$ because sum of product of two integers is an integer and hence their difference is again an integer.
 2) $a*b = a+b - ab$
 $= b+a-ba$ (because addition multiplication and commutative on Z)
 $= b*a$

Associative Property

A എന്ന ഗണത്തിലെ '*' എന്ന ബൈനറി ഓപ്പറേഷൻ A യിൽ associative ആകണമെങ്കിൽ $(a*b)*c = a*(b*c)$, for every element a, b, c in A ആയിരിക്കണം.

Example: സങ്കലനം (addition), ഗുണനം എന്നീ ഓപ്പറേഷൻസ് R എന്ന ഗണത്തിൽ associative ആണ്.

Example: R എന്ന ഗണത്തിലെ ഒരു ബൈനറി ഓപ്പറേഷൻ ആണ് $a*b = \frac{ab}{2}$ താഴെകൊടുത്തിരിക്കുന്നത്.

$$a * b = \frac{ab}{2}, a, b \in R$$

* associative ആണോ എന്ന് പരിശോധിക്കുക.

Answer

$$a * b = \frac{ab}{2}, a, b \in R$$

a, b, c $\in R$ $(a*b)*c = a*(b*c)$ ആണോ എന്ന് പരിശോധിക്കാം.

$$\begin{aligned} (a*b)*c &= d*c, (d=a*b \in R) \\ &= \frac{dc}{2} \text{ (നിർവചനപ്രകാരം)} \\ &= \frac{(a*b)c}{2} \\ &= \frac{(\frac{ab}{2})c}{2} \\ &= \frac{(ab)c}{2} \times \frac{1}{2} = \frac{abc}{4} \dots\dots(1) \end{aligned}$$

(കാരണം സാധാരണ ഗുണിതം R ൽ അസോസിയേറ്റീവ് ആണ്.)

$$a*(b*c) = a*d, d=b*c$$

$$\begin{aligned}
&= \frac{ad}{2} \\
&= \frac{a.(b*c)}{2} \\
&= \frac{a.(\frac{bc}{2})}{2} \\
&= \frac{a(bc)}{2} \times \frac{1}{2} \\
&= \frac{a(bc)}{4} \\
&= \frac{abc}{4} \dots\dots\dots(2)
\end{aligned}$$

∴ 1, 2 ഇവയിൽ നിന്ന് $a*(b*c) = a*(b*c)$ എന്നെഴുതാം.

∴ Associative ആണ്.

2) R എന്ന ഗണത്തിലെ ഒരു ഓപ്പറേഷനാണ് താഴെകൊടുത്തിരിക്കുന്നത്.

$$a*b = a+2b, \forall a, b \in R$$

1. '*' ബൈനറി ഓപ്പറേഷൻ ആണോ എന്ന് പരിശോധിക്കുക.
2. '*' Commutative ആണോ എന്ന് പരിശോധിക്കുക.

$(1*2)*3$ ഉം $1*(2*3)$ ഇവ കാണുക.

Ans: Given $a*b = a+2b$

$$a, b \in R \Rightarrow a, 2b \in R$$

$$\Rightarrow a+2b \in R$$

$$\Rightarrow a*b \in R$$

∴ * ഒരു binary operation ആണ്.

2. $a*b = a+2b$

$$b*a = b+2a$$

∴ * commutative അല്ല.

3. നമുക്ക് അടുത്തതായി $(a*b)*c = a*(b*c)$ എന്ന് പരിശോധിക്കണം. a, b, c ഇവ R ലെ അംഗങ്ങളാണെന്നിരിക്കട്ടെ.

$$(a*b)*c = (d*c), d=a*b$$

$$= d+2c$$

$$\begin{aligned}
&= (a*b)+2c \\
&= a+2b+2c \dots\dots\dots(A) \\
a*(b*c) &= a*p, p=b*c \\
&= a+2p \\
&= a+2(b*c) \\
&= a+2(b+2c) \\
&= a+2b+4c \dots\dots\dots(B)
\end{aligned}$$

(A), (B) എന്നിവയിൽ $(a*b)*c \neq a*(b*c)$ എന്ന് ലഭിക്കുന്നു.

4. $(1*2)*3 = (d*3), d=1*2$

$$\begin{aligned}
&= d+2.3 \\
&= d+6 \\
&= (1*2)+6 \\
&= 1+2*2+6 \\
&= 1+4+6 \\
&= 5+6 = 11 \\
1*(2*3) &= 1*p, = 2*3 \\
&= 1+2p \\
&= 1+2(2*3) = 1+2(2+2*3) \\
&= 1+4+12 = 17
\end{aligned}$$

Identity Element

ഏതൊരു എണ്ണൽസംഖ്യയോടും 1 (ഒന്ന്) എന്ന എണ്ണൽസംഖ്യകൊണ്ട് ഗുണിച്ചാൽ അതേ സംഖ്യ ലഭിക്കുമെന്നറിയാം.

അതായത് a ഒരു എണ്ണൽസംഖ്യയായാൽ $a*1=1*a=a$ എന്നെഴുതാം. ഇങ്ങനെ ലഭിക്കുന്ന '1'നെ multiplicative identity എന്നുവിളിക്കുന്നു. ഏതൊരു integers നോടും 0 കൂട്ടിയാൽ അതേ integer ലഭിക്കും.

അതായത് $a+0 = 0+a=a, \forall a \in Z$ ഇവിടെ '0' യെ additional identity എന്നുവിളിക്കുന്നു. *, A എന്ന ഗണത്തിലെ ഒരു ബൈനറി ഓപ്പറേഷനാണ്. A എന്ന ഗണത്തിലെ ഒരംഗമാണ് 'e'. e എന്ന അംഗത്തോട് A യിലെ ഏതൊരു അംഗവും ചേർന്ന് * എന്ന operation നടത്തിയാൽ അതേ അംഗം ലഭിക്കുന്നുണ്ടെങ്കിൽ e-യെ Aയിലെ identity element with respect to * എന്നുപറയുന്നു.

$$\text{ie, } a * e = a, \forall a \in A \quad \text{ie, } a \cdot e = a = e \cdot a \quad \forall a \in A$$

ഉദാഹരണം

1. N has no identity element with respect to addition because $a+0=a, \forall a \in N$ but $0 \notin N$
2. R എന്ന ഗണത്തിലെ identity element കാണുക.

R എന്ന ഗണത്തിലെ ബൈനറി ഓപ്പറേഷൻ താഴെകൊടുത്തിരിക്കുന്നു.

$$a * b = \frac{ab}{4}, \forall a, b \in R$$

Solution

R എന്ന ഗണത്തിലെ identity element e ആണെന്ന് തിരിച്ചറിയട്ടെ.

$$a * e = 1, \forall a \in R$$

$$\text{ie, } \frac{ae}{4} = a, \text{ by definition of '*'}$$

$$ae = 4a$$

$$e = \frac{4a}{a}, a \neq 0$$

$$= 4 \in R$$

$$a=0 \text{ ആണെങ്കിൽ } 0 * e = \frac{0 \cdot e}{4} = 0$$

∴ 4, R ലെ identity element ആണ്.

Existence of inverse element

A എന്ന ഗണത്തിലെ ഒരു ബൈനറി ഓപ്പറേഷനാണ് *, identity element e ഉം ആണ്.

A യിലെ 'a' എന്ന അംഗത്തിന് inverse ഉണ്ടെന്ന് പറയണമെങ്കിൽ $a * b = b * a = e$ എന്ന വിധത്തിൽ A യിൽ b എന്ന ഒരംഗം ഉണ്ടായിരിക്കണം. ഇവിടെ b യെ a യുടെ inverse എന്ന് വിളിക്കുന്നു. ഇതിനെ a^{-1} എന്നെഴുതി സൂചിപ്പിക്കുന്നു. അതായത് $b = a^{-1}$

Example 1

R എന്ന ഗണത്തിലെ identity element ആണ് '1'. ഇവിടെ binary operation സാധാരണ ഗുണനം ആണ്. ഇവിടെ 2 ന്റെ inverse $\frac{1}{2}$ ആണ്. കാരണം $2 * \frac{1}{2} = 1 = \frac{1}{2} * 2$. പൂജ്യത്തിന് inverse ഇല്ല.

Example 2

R എന്ന ഗണത്തിലെ ഒരു ബൈനറി ഓപ്പറേഷൻ ആണ് താഴെകൊടുത്തിട്ടുള്ളത്.

$$a * b = \frac{ab}{3}, \forall a, b \in R$$

1. Identity element കാണുക.

2. 2 എന്ന അംഗത്തിന്റെ inverse കാണുക.

Answer :

1. R ലെ identity element 'e' ആണെന്ന് വിചാരിക്കുക.

Then $ax = a, \forall a \in R$

$$\frac{ae}{3} = a \text{ (by definition of x)}$$

$$ae = 3a$$

$$e = 3, a \neq 0$$

When $a=0, 0.e = 0.3 = 0$

$\therefore 3, R$ ലെ identity element ആണ്.

2. 2 ന്റെ inverse ആണ് b എന്നിരിക്കട്ടെ. അപ്പോൾ,

$$2*b = e$$

$$2*b = 3$$

$$\frac{2b}{3} = 3 \text{ (by definition)}$$

$$2b = 9$$

$$b = \frac{9}{2} \in R$$

Unit Test

Time : 45 mts

Max Score : 20

- 1) $f : \{1, 3, 4\} \rightarrow \{1, 2, 5\}$ and $g : \{1, 2, 5\} \rightarrow \{1, 3\}$ be given by
 $f = \{(1, 2), (3, 5), (4, 1)\}$ and $g = \{(1, 3), (2, 3), (5, 1)\}$. Find $(g \circ f)(3)$.
- 2) Let $f : \mathbb{R} \rightarrow \mathbb{R}$ defined as $f(x) = 3x$. Choose the correct answer.
 - 1) f is one-one
 - 2) f is many one - onto
 - 3) f is one-one not onto
 - 4) f is neither one-one nor onto.
- 3) $f : \mathbb{R} \rightarrow \mathbb{R}$ be given by $f(x) = (3 - x^3)^{1/3}$ then $(f \circ f)(x) = _ \left(x^{1/5}, x^3, x, 3 - x^3 \right)$
- 4) $f : \mathbb{R} \rightarrow \mathbb{R}$ by $f(x) = 2x$ then $f^{-1}(x) = \dots\dots\dots$
- 5) Let $f : \mathbb{R} \rightarrow \mathbb{R}$ with $(f \circ f)(x) = x, \forall x \in \mathbb{R}$. What is the inverse of 'f'. (1 mark each)
- 6) Let '*' be a binary operation on \mathbb{R} defined as $a * b = \frac{ab}{4}$.
 - a) Prove that '*' is commutative and associative. (3)
 - b) Find the identity element in \mathbb{R} with respect to '*' (1)
 - c) Find the inverse of 6 in \mathbb{R} with respect to '*' (1)
- 7) Give an example for not an equivalence relations which is symmetric and reflexive on
 $A = \{1, 2, 3, 4\}$. (1)
- 8) Consider the function $f : [-1, 1] \rightarrow \mathbb{R}$, given by $f(x) = \frac{x}{x+2}$
 - a) Show that f is one-one (2)
 - b) Does $1 \in \mathbb{R}$ have preimage in $[-1, 1]$. Justify your answer. (2)
 - c) Is 'f' onto? (1)
- 9) Let $f : N \rightarrow Y$ be a function defined as $f(x) = 4x + 3$, where
 $Y = \{Y \in N : y = 4x + 3, x \in N\}$.
 - a) Write one element in Y. (1)
 - b) Show that f is invertible (2)
 - c) Find the inverse of 'f' (1)

Solution

- 1) $(g \circ f)(3) = g(f(3))$

$= g(5)$ $= 1$	$f(3) = 5$
-------------------	------------
- 2) f is one-one
 For, if $f(x_1) = f(x_2)$
 $\Rightarrow 3x_1 = 3x_2$

$$\Rightarrow x_1 = x_2$$

f is onto

For, if $y \in R$ with $f(x) = y$

$$\Rightarrow 3x = y$$

$$\Rightarrow x = \frac{y}{3} \in \mathbb{R}$$

ie, for any $y \in R$ we can find $x \in R$ with $f(x) = y$

3) Given $f(x) = (3 - x^3)^{\frac{1}{3}}$

$$(f \circ f)(x) = f(f(x))$$

$$= f\left((3 - x^3)^{\frac{1}{3}}\right)$$

$$= \left\{ 3 - \left[(3 - x^3)^{\frac{1}{3}} \right]^3 \right\}^{\frac{1}{3}}$$

$$= \left[3 - (3 - x^3) \right]^{\frac{1}{3}} = \left[3 - 3 + x^3 \right]^{\frac{1}{3}}$$

$$= \left[x^3 \right]^{\frac{1}{3}} = x$$

Replace

x by $(3 - x^3)^{\frac{1}{3}}$

$$\left[(3 - x^3)^{\frac{1}{3}} \right]^3$$

$$= 3 - x^3$$

Answers

4) $f^{-1}(x) = \frac{x}{2}$

5) f

6) Given $a * b = \frac{ab}{4}$, $a, b, \in \mathbb{R}$

a) $*$ is commutative

$$\text{For, } a * b = \frac{ab}{4}$$

$$= \frac{ba}{4} \quad (\because \text{usual multiplication is commutative})$$

$$= b * a \quad (\text{by definition of } *)$$

$*$ is associative

For, $(a * b) * c = p * c$ where $p = a * b$

$$= \frac{pc}{4}, \text{ by definition}$$

$$= \frac{(a * b)c}{4} = \frac{(ab)c}{4} = \frac{(ab)c}{4} = \frac{abc}{4} \times \frac{1}{4} = \frac{abc}{16} \dots\dots\dots(1)$$

$$= a * (b * c) = a * q, \quad q = b * c$$

$$= \frac{aq}{4} \text{ by definition}$$

$$= \frac{a \frac{(b * c)}{4}}{4} = \frac{a(bc)}{4} \times \frac{1}{4}$$

$$\frac{abc}{16} \dots (2)$$

From (1) and (2) * is association.

b) Let e be the identity element in \mathbb{R} w.r.t *

The we've $a * e = a, \forall a \in \mathbb{R}$

$$\frac{ae}{4} = a, \text{ by definition}$$

$$ae = 4a$$

dividing through by a, $e=4$, if $a \neq 0$

When $a=0, 0 \cdot 4 = 0$

Hence 4 is the identity element in \mathbb{R} .

c) Let 'b' is the inverse of 6.

Then $b * 6 = 4$

(If 'b' is the inverse of a then we have $a * b = b * a = e$)

$$\frac{b * 6}{4} = 4$$

$$6b = 16$$

$$b = \frac{16}{6} = \frac{8}{3} \in \mathbb{R}$$

$\frac{8}{3}$ is the inverse of 6.

7)

8) Given $f(x) = \frac{x}{x+2}, \quad x \in [-1, 1]$

f is one-one

$$\text{a) For } f(x_1) = f(x_2) \Rightarrow \frac{x_1}{x_1+2} = \frac{x_2}{x_2+2}$$

$$\Rightarrow x_1(x_2+2) = x_2(x_1+2)$$

$$\Rightarrow x_1x_2 + 2x_1 = x_1x_2 + 2x_2$$

$$\Rightarrow 2x_1 = 2x_2$$

$$\Rightarrow x_1 = x_2$$

b) Let $1 \in \mathbb{R}$ has preimage $[-1,1]$

Then $x \in [-1,1]$ with $f(x) = 1$

$$\text{ie, } \frac{x}{x+2} = 1$$

$$x = x + 2 \Rightarrow x - x = 2$$

$\Rightarrow 0 = 2$ which is a absurd. Therefore 1 has no preimage in \mathbb{R} .

c) f is not onto, because $1 \in \mathbb{R}$ has no preimage in $[-1,1]$

9) a) Any element in y is of the form

$$y = 4x + 3, \quad x \in N$$

we have $1 \in N \quad Y = 4 + 3 = 7$

$$7 \in Y$$

b) Given $f : N \rightarrow Y$

For finding f , first our aim is to define a function $g : Y \rightarrow N$

Take $y \in Y$. Then $y = 4x + 3, \quad x \in N$

$$4x = y - 3$$

$$x = \frac{y-3}{4} \in N$$

$$\text{Define } g(y) = \frac{y-3}{4}$$

clearly $g : Y \rightarrow N$

Claim: $(gof)(x) = x, \quad \forall x \in N$ and $(fog)(y) = y, \quad \forall y \in Y$

Let $x \in N$

$(gof)(x) = g(f(x)) = g(4x + 3)$ by definition of f .

$$= \frac{4x + 3 - 3}{4} = \frac{4x}{4} = x$$

Let $y \in Y$

$$\begin{aligned} f(fog)(y) &= f(g(y)) \\ &= \left(\frac{y-3}{4} \right) = 4 \left(\frac{y-3}{4} \right) + 3 \\ &= y-3+3 \end{aligned}$$

$$= y$$

$$\therefore (fog)(y) = y, \quad \forall y \in Y$$

Now $g : Y \rightarrow N$ such that $(fog)(y) = y, \quad \forall y \in Y$ and $(gof)(x) = x, \quad \forall x \in N$

Hence g is the inverse of f .

c) The inverse of f is g

$$\text{ie, } f^{-1} = g$$

2. INVERSE TRIGNOMETRIC FUNCTION

Important Results

1.

Function	Domain	Range
Sine	\mathbb{R}	$(-1, 1)$
Cosine	\mathbb{R}	$(-1, 1)$
Tangent	$\mathbb{R} - \{(2n + 1)\pi\} \ 2n \in \mathbb{Z}$	\mathbb{R}
Cotangent	$\mathbb{R} \setminus \{x : x = n\pi\}$	\mathbb{R}
Secant	$\mathbb{R} \setminus \{x : x = (2n + 1)\frac{\pi}{2}\}$	$\mathbb{R} \setminus (-1, 1)$
Cosecant	$\mathbb{R} \setminus \{x : x = n\pi\}$	$\mathbb{R} \setminus (-1, 1)$

2.

Function	Domain	Range
$Y = \sin^{-1}x$	$[-1, 1]$	$\left[\frac{-\pi}{2}, \frac{\pi}{2} \right]$
$Y = \cos^{-1}x$	$[-1, 1]$	$[0, \pi]$
$Y = \operatorname{cosec}^{-1}x$	$\mathbb{R} \setminus \{-1, 1\}$	$\left[-\frac{\pi}{2}, \frac{\pi}{2} \right] - \{0\}$
$Y = \sec^{-1}x$	$\mathbb{R} \setminus \{-1, 1\}$	$[0, \pi] - \left\{ \frac{\pi}{2} \right\}$
$Y = \tan^{-1}x$	\mathbb{R}	$\left(\frac{-\pi}{2}, \frac{\pi}{2} \right)$
$Y = \cot^{-1}x$	\mathbb{R}	$(0, \pi)$

Values of Trigonometric Functions in Particular angles

Angles Trigonometric function	0	$\pi/6$	$\pi/4$	$\pi/3$	$\pi/2$	π	$3\pi/2$	2π
Sine	0	$1/2$	$1/\sqrt{2}$	$\sqrt{3}/2$	1	0	-1	0
Cosine	1	$\frac{\sqrt{3}}{2}$	$\frac{1}{\sqrt{2}}$	$\frac{1}{2}$	0	-1	0	1
Tan	0	$\frac{1}{\sqrt{3}}$	1	$\sqrt{3}$	not defined	0	not defined	0
Cosec	not defined	2	$\sqrt{2}$	$\frac{2}{\sqrt{3}}$	1	not defined	-1	not defined
Sec	1	$\frac{2}{\sqrt{3}}$	$\sqrt{3}$	2	not defined	-1	not defined	1
Cot	not defined	$\sqrt{3}$	1	$\frac{1}{\sqrt{3}}$	0	not defined	0	not defined

Important Trigonometric Identities

1. $\sin^2\theta + \cos^2\theta = 1$
2. $1 - \cos^2\theta = \sin^2\theta$
3. $1 - \sin^2\theta = \cos^2\theta$
4. $1 + \tan^2\theta = \sec^2\theta$
5. $1 + \cot^2\theta = \operatorname{cosec}^2\theta$
6. $\sin 2\theta = 2\sin\theta\cos\theta$
7. $1 + \cos 2\theta = 2\cos^2\theta$
8. $1 - \cos 2\theta = 2\sin^2\theta$
9. $1 + \cos\theta = 2\cos^2\left(\frac{\theta}{2}\right)$
10. $1 - \cos\theta = 2\sin^2\left(\frac{\theta}{2}\right)$

$$11. \quad \tan(A + B) = \frac{\tan A + \tan B}{1 - \tan A \cdot \tan B}$$

$$12. \quad \tan(A - B) = \frac{\tan A - \tan B}{1 + \tan A \cdot \tan B}$$

$$13. \quad \sin 2\theta = \frac{2 \tan \theta}{1 + \tan^2 \theta}$$

$$14. \quad \cos 2\theta = \frac{1 - \tan^2 \theta}{1 + \tan^2 \theta}$$

$$15. \quad \tan 2\theta = \frac{2 \tan \theta}{1 - \tan^2 \theta}$$

$$16. \quad \sin\left(\frac{\pi}{2} - \theta\right) = \cos \theta$$

$$17. \quad \cos\left(\frac{\pi}{2} - \theta\right) = \sin \theta$$

$$18. \quad \tan\left(\frac{\pi}{2} - \theta\right) = \cot \theta$$

$$19. \quad \sec\left(\frac{\pi}{2} - \theta\right) = \operatorname{cosec} \theta$$

$$20. \quad \operatorname{cosec}\left(\frac{\pi}{2} - \theta\right) = \sec \theta$$

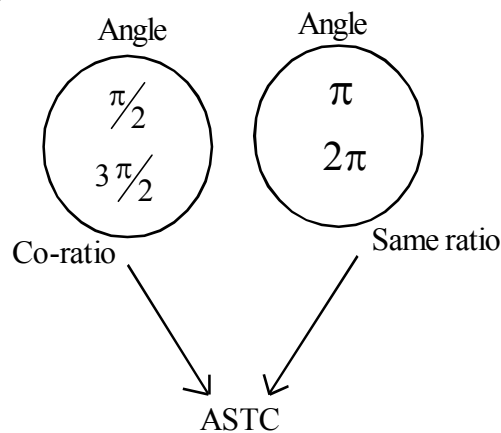

Sine ന്റെ co-ratio Cosine, Tan ന്റെ co-ratio cot ഉം, Secന്റെ co-ratio cosec ഉം ആണ്. ASTC ഉപയോഗിച്ച് functional sign തീരുമാനിക്കുകയും ചെയ്യാം.

ഉദാ: $\sin\left(3\frac{\pi}{2} - \theta\right) = -\cos \theta$ കാരണം Sine ന്റെ co-ratio Cosine ഉം $\left(3\frac{\pi}{2} - \theta\right)$ രണ്ടാമത്തെ quadrantൽ ആയതുകൊണ്ട് -ve ഉം ആണ്.

For suitable value of Domain

- $Y = \sin^{-1}x \Rightarrow x = \sin y$
- $\sin(\sin^{-1}x) = x, x \in [-1, 1]$
- $\sin^{-1}(\sin x) = x, x \in \left[\frac{\pi}{2}, \frac{\pi}{2}\right]$
- $\sin^{-1}(1/x) = \operatorname{Cosec}^{-1}x, x \geq 1 \text{ or } x \leq -1$
- $\cos^{-1}(1/x) = \operatorname{Sec}^{-1}x, x \geq 1 \text{ or } x \leq -1$
- $\cos^{-1}(1/x) = \operatorname{Sec}^{-1}x, |x| \geq 1$
- $\tan^{-1}(1/x) = \operatorname{Cot}^{-1}x, x > 0$
- $\cos^{-1}(-x) = \pi - \cos^{-1}(x), x \in [-1, 1]$
- $\operatorname{Cot}^{-1}(-x) = \pi - \operatorname{Cot}^{-1}(x), x \in \mathbb{R}$
- $\operatorname{Sec}^{-1}(-x) = \pi - \operatorname{Sec}^{-1}(x), |x| \geq 1$
- $\sin^{-1}(-x) = -\sin^{-1}(x), x \in [-1, 1]$
- $\tan^{-1}(-x) = -\tan^{-1}(x), x \in \mathbb{R}$
- $\operatorname{Cosec}^{-1}(-x) = -\operatorname{Cosec}^{-1}(x), |x| \geq 1$
- $\sin^{-1}x + \cos^{-1}x = \pi/2, x \in [-1, 1]$
- $\tan^{-1}x + \operatorname{Cot}^{-1}x = \pi/2, x \in \mathbb{R}$
- $\operatorname{Sec}^{-1}x + \operatorname{Cosec}^{-1}x = \pi/2, |x| \geq 1$
- $\tan^{-1}x + \tan^{-1}y = \tan^{-1}\left(\frac{x+y}{1-xy}\right), xy < 1$
- $\tan^{-1}x - \tan^{-1}y = \tan^{-1}\left(\frac{x-y}{1+xy}\right), xy > -1$
- $2\tan^{-1}x = \sin^{-1}\left(\frac{2x}{1-x^2}\right), |x| \leq 1$
- $2\tan^{-1}x = \cos^{-1}\left(\frac{1-x^2}{1+x^2}\right), x \geq 0$
- $2\tan^{-1}x = \tan^{-1}\left(\frac{2x}{1-x^2}\right), -1 < x < 1$

- $\sin^{-1}(2 \times \sqrt{1-x^2}) = 2\sin^{-1}x, 1/\sqrt{2} \leq x \leq 1/\sqrt{2}$
- $\sin^{-1}(2 \times \sqrt{1-x^2}) = 2\cos^{-1}x, 1/\sqrt{2} \leq x \leq 1$

Complete the Table

Function	Principal Value
$\sin^{-1}(\frac{1}{2})$	$\frac{\pi}{6}$
$\cos^{-1}(-\frac{1}{2})$	$\frac{2\pi}{3}$
$\tan^{-1}(-1)$	$-\frac{\pi}{4}$
$\sin^{-1}(-\frac{1}{2})$	$-\frac{\pi}{6}$
$\cos^{-1}(-\frac{1}{\sqrt{2}})$	$\frac{3\pi}{4}$
$\tan^{-1}(-\sqrt{3})$	$\frac{2\pi}{3}$

Let $y = \sin^{-1}(\frac{1}{2})$, then $\sin y = \frac{1}{2}$

Principal value branch of $\sin^{-1}x$ is $[-\frac{\pi}{2}, \frac{\pi}{2}]$. Therefore $\phi = \frac{\pi}{6} \in [-\frac{\pi}{2}, \frac{\pi}{2}]$ satisfies the condition

$\sin \frac{\pi}{6} = \frac{1}{2}$. Therefore $\frac{\pi}{6}$ is the principal value.

Let $y = \cos^{-1}(-\frac{1}{2})$. Then $\cos y = -\frac{1}{2}$ principal branch of \cos^{-1} is $[0, \pi]$

$\cos y = -\frac{1}{2}$ shows that angle in the second quadrant.

\therefore Principal Value is $\pi - \frac{\pi}{3} = 2\frac{\pi}{3}$

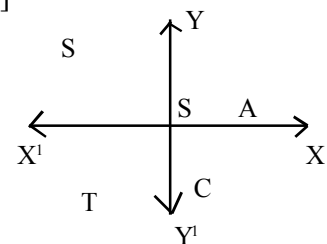

1. Find the principal value of $\cot^{-1}\left(\frac{1}{\sqrt{3}}\right)$

Let $y = \cot^{-1}\left(\frac{1}{\sqrt{3}}\right)$

$$\Rightarrow \cot y = \frac{1}{\sqrt{3}} = \cot\left(\frac{\pi}{3}\right)$$

$$\Rightarrow y = \frac{\pi}{3}$$

2. Find the principal value of $\text{Cot}^{-1}\left(\frac{-1}{\sqrt{3}}\right)$

Solution

Let $y = \text{Cot}^{-1}\left(\frac{-1}{\sqrt{3}}\right)$

Then $\text{Cot } y = \frac{-1}{\sqrt{3}} \dots \dots \dots (1)$

we've $\text{cot}\left(\frac{\pi}{3}\right) = \frac{1}{\sqrt{3}}$

Also we've $\text{Cot}\left(\pi - \frac{\pi}{3}\right) = -\text{Cot } \frac{\pi}{3} = -\frac{1}{\sqrt{3}}$

i.e., $\text{Cot}\left(\frac{3\pi - \pi}{3}\right) = -\frac{1}{\sqrt{3}}$

i.e., $\text{Cot}\left(\frac{2\pi}{3}\right) = \frac{1}{\sqrt{3}}$

From (1) $\text{Cot } y = \frac{-1}{\sqrt{3}} = \text{Cot}\left(\frac{2\pi}{3}\right)$

$\therefore y = \frac{2\pi}{3} \in (0, \pi)$

Problems

1. Find the principal value of $\text{Cos}^{-1}\left(\frac{\sqrt{3}}{2}\right)$
2. Find the principal value of $\tan^{-1}(-\sqrt{3})$
3. Find the principal value of $\text{Cos}^{-1}\left(-\frac{1}{\sqrt{2}}\right)$

Problems

1. Write principal value of Cos^{-1} function
2. Evaluate $\text{Tan}^{-1}(-1) + \text{Cos}^{-1}\left(\frac{-1}{2}\right) + \text{Sin}^{-1}\left(\frac{-1}{2}\right)$

Answers

a. $[0, \pi]$

b. We've $\tan^{-1}(-1) = -\tan^{-1}1$

$$= \frac{-\pi}{4}$$

$$\cos^{-1}\left(\frac{-1}{2}\right) = \pi - \cos^{-1}\left(\frac{1}{2}\right) \quad (\text{Since } \cos^{-1}(-x) = \pi - \cos^{-1}(x))$$

$$= \pi - \frac{\pi}{3}$$

$$= \frac{2\pi}{3}$$

$$\sin^{-1}\left(\frac{-1}{2}\right) = \sin^{-1}\left(\frac{1}{2}\right) \quad (\because \sin^{-1}(-x) = -\sin^{-1}(x))$$

$$= \frac{-\pi}{6}$$

$$\therefore \tan^{-1}(-1) + \cos^{-1}(-\frac{1}{2}) + \sin^{-1}(-\frac{1}{2})$$

$$= \frac{-\pi}{4} + \frac{2\pi}{3} - \frac{\pi}{6}$$

$$= \frac{-3\pi}{12} + \frac{8\pi}{12} - \frac{2\pi}{12}$$

$$= \frac{8\pi - 5\pi}{12}$$

$$= \frac{3\pi}{12}$$

3. Find the principal value of $\sin^{-1}\left(\frac{1}{\sqrt{2}}\right)$

$$\text{Let } y = \sin^{-1}\left(\frac{1}{\sqrt{2}}\right) \Rightarrow \sin y = \frac{1}{\sqrt{2}} = \sin \frac{\pi}{4}$$

$$\Rightarrow y = \frac{\pi}{4} \in \left(-\frac{\pi}{2}, \frac{\pi}{2}\right)$$

$$\text{ie, } \sin^{-1}\left(\frac{1}{\sqrt{2}}\right) = \frac{\pi}{4}$$

Problem

1. Show that $\tan^{-1}\left(\frac{1}{2}\right) + \tan^{-1}\left(\frac{2}{11}\right) = \tan^{-1}\left(\frac{3}{4}\right)$

Ans: We've $\tan^{-1}x + \tan^{-1}(y) = \tan^{-1}\left(\frac{x+y}{1-xy}\right)$

$$\text{L.H.S} = \tan^{-1}\left(\frac{1}{2}\right) + \tan^{-1}\left(\frac{2}{11}\right)$$

$$= \tan^{-1}\left(\frac{\frac{1}{2} + \frac{2}{11}}{1 - \frac{1}{2} \times \frac{2}{11}}\right)$$

$$= \tan^{-1}\left(\frac{\frac{15}{22}}{\frac{22}{22} - \frac{2}{22}}\right)$$

$$= \tan^{-1}\left(\frac{\frac{15}{22}}{\frac{20}{22}}\right)$$

$$= \tan^{-1}\left(\frac{15}{22} \times \frac{22}{20}\right)$$

$$= \tan^{-1}\left(\frac{15}{20}\right)$$

$$= \tan^{-1}\left(\frac{3}{4}\right) = \text{R.H.S}$$

2. Express $\tan^{-1}\left(\frac{\cos x}{1 - \sin x}\right)$, $\frac{\pi}{2} < x < \frac{3\pi}{2}$ in the simplest form.

Ans: We've $\tan^{-1}(\tan \theta) = \theta$

Hence write $\frac{\cos x}{1 - \sin x}$ in tan function.

$$\frac{\cos x}{1 - \sin x} = \frac{\sin\left(\frac{\pi}{2} - x\right)}{1 - \cos\left(\frac{\pi}{2} - x\right)},$$

we've $\sin\left(\frac{\pi}{2} - x\right) = \cos x$

$\cos\left(\frac{\pi}{2} - x\right) = \sin x$

$$= \frac{2\sin\left(\frac{\frac{\pi}{2} - x}{2}\right)\cos\left(\frac{\frac{\pi}{2} - x}{2}\right)}{2\sin^2\left(\frac{\frac{\pi}{2} - x}{2}\right)}$$

$$\left(\sin\theta = 2\sin\frac{\theta}{2}\cos\frac{\theta}{2} \text{ and } 1 - \cos\theta = 2\sin^2\left(\frac{\theta}{2}\right) \right)$$

$$= \frac{\sin\left(\frac{\frac{\pi}{2} - x}{2}\right)\cos\left(\frac{\frac{\pi}{2} - x}{2}\right)}{\sin^2\left(\frac{\frac{\pi}{2} - x}{2}\right)}$$

$$= \frac{\sin\left(\frac{\frac{\pi}{2} - x}{2}\right)\cos\left(\frac{\frac{\pi}{2} - x}{2}\right)}{\sin\left(\frac{\frac{\pi}{2} - x}{2}\right)\cdot\sin\left(\frac{\frac{\pi}{2} - x}{2}\right)}$$

$$= \frac{\cos\left(\frac{\frac{\pi}{2} - x}{2}\right)}{\sin\left(\frac{\frac{\pi}{2} - x}{2}\right)}$$

$$= \cot\left(\frac{\frac{\pi}{2} - x}{2}\right)$$

$$= \tan\left[\frac{\pi}{2} - \left(\frac{\frac{\pi}{2} - x}{2}\right)\right]$$

$$\left(\therefore \tan\left(\frac{\pi}{2} - \theta\right) = \cot\theta \right)$$

$$= \tan\left(\frac{\pi}{2} - \frac{\frac{\pi}{2} - x}{2}\right)$$

$$= \tan\left(\frac{\pi}{4} + \frac{x}{2}\right)$$

$$\begin{aligned} \therefore \tan^{-1}\left(\frac{\cos x}{1 - \sin x}\right) &= \tan^{-1}\left(\tan\left(\frac{\pi}{4} + \frac{x}{2}\right)\right) \\ &= \frac{\pi}{4} + \frac{x}{2} \end{aligned}$$

Example 3

Write $\cot^{-1}\left(\frac{1}{\sqrt{x^2 - 1}}\right)$, $|x| > 1$, in the simplest form.

Solution

we've $\cot^{-1}(\cot \theta) = \theta$

write $\frac{1}{\sqrt{x^2 - 1}}$ in the cot function.

$$\frac{1}{\sqrt{x^2 - 1}} = \frac{1}{\sqrt{\sec^2 \theta - 1}}$$

Put $x = \sec \theta$

$$\theta = \sec^{-1} x$$

$$= \frac{1}{\sqrt{\tan^2 \theta}}, \text{ we've } \sec^2 \theta - 1 = \tan^2 \theta$$

$$= \frac{1}{\tan \theta}$$

$$= \cot \theta$$

$$\therefore \cot^{-1}\left(\frac{1}{\sqrt{x^2 - 1}}\right) = \cot^{-1}\left(\frac{1}{\tan \theta}\right)$$

$$= \cot^{-1}(\cot \theta)$$

$$= \theta, = \sec^{-1} x$$

Example 4

Show that $\sin^{-1}\left(\frac{3}{5}\right) - \sin^{-1}\left(\frac{8}{17}\right) = \cos^{-1}\left(\frac{84}{85}\right)$

Solution

$$\text{Let } x = \sin^{-1}\left(\frac{3}{5}\right), y = \sin^{-1}\left(\frac{8}{17}\right)$$

$$\text{Then } \sin x = \frac{3}{5} \text{ and } \sin y = \frac{8}{17}$$

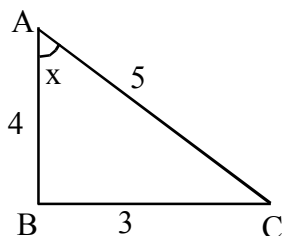

$$\begin{aligned} AB^2 + BC^2 &= AC^2 \\ AB^2 &= AC^2 - BC^2 \\ &= 5^2 - 3^2 \\ &= 25 - 9 \\ &= 16 \\ AB &= \sqrt{16} = 4 \end{aligned}$$

$$\begin{aligned} \cos x &= \frac{\text{adjacent side}}{\text{hypotenuse}} \\ &= \frac{4}{5} \end{aligned}$$

Also

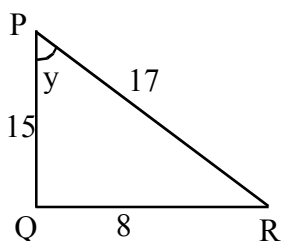

$$\begin{aligned} \sin y &= \frac{8}{17} \\ PQ^2 &= 17^2 - 8^2 \\ &= 289 - 64 \\ &= 225 \\ PQ &= 15 \end{aligned}$$

$$\therefore \cos y = \frac{15}{17}$$

we've $\cos(x-y) = \cos x \cos y + \sin x \sin y$

$$\begin{aligned} &= \frac{4}{5} \frac{15}{17} + \frac{3}{5} \times \frac{8}{17} \\ &= \frac{60}{85} + \frac{24}{85} \\ &= \frac{84}{85} \end{aligned}$$

$$\therefore x - y = \cos^{-1}\left(\frac{84}{85}\right)$$

$$\text{ie, } \sin^{-1}\left(\frac{3}{5}\right) - \sin^{-1}\left(\frac{8}{17}\right) = \cos^{-1}\left(\frac{84}{85}\right)$$

5. Show that $\sin^{-1}\left(\frac{12}{13}\right) + \cos^{-1}\left(\frac{4}{5}\right) + \tan^{-1}\left(\frac{63}{16}\right) = \pi$

Let $\sin^{-1}\left(\frac{12}{13}\right) = x$; $y = \cos^{-1}\left(\frac{4}{5}\right)$; $\tan^{-1}\left(\frac{63}{16}\right) = z$

Then $\sin x = \frac{12}{13}$; $\cos y = \frac{4}{5}$, $\tan z = \frac{63}{16}$

we've $\tan(x+y) = \frac{\tan x + \tan y}{1 - \tan x \tan y}$

$\sin x = \frac{12}{13}$

$\therefore \tan x = \frac{\text{Opposite side}}{\text{Adjacent side}}$

$= \frac{12}{5}$

$AB = \sqrt{13^2 - 12^2}$

$= \sqrt{169 - 144}$

$= \sqrt{25}$

$= 5$

$\cos y = \frac{4}{5}$

$\tan y = \frac{3}{4}$

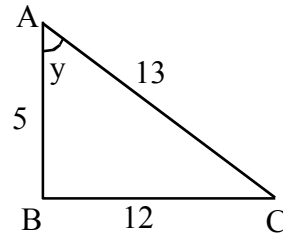

Here $\tan(x+y) = \frac{\tan x + \tan y}{1 - \tan x \cdot \tan y}$

$= \frac{\frac{12}{5} + \frac{3}{4}}{1 - \frac{12}{5} \cdot \frac{3}{4}} = \frac{\frac{48}{20} + \frac{15}{20}}{\frac{20}{20} - \frac{36}{20}}$

$= \frac{63}{20} \times \frac{20}{-16} = \frac{-16}{16}$

$\therefore \tan(x+y) = -\tan z$

$\therefore \tan(x+y) = \tan(-z)$ or $\tan(x+y) = \tan(\pi - z)$

$\therefore x + y = -z$ or $x + y = \pi - z$

Since x and y are positive

$x + y \neq -z$

$\therefore x + y = \pi - z$

i.e, $x + y + z = \pi$

Hence the result.

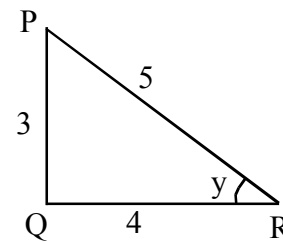

Evaluate the following :

- $\text{Cos}^{-1}(\text{Cos} \frac{13\pi}{6})$
- $\text{Tan}^{-1}(\text{Tan} \frac{7\pi}{6})$
- $\text{Tan}^{-1} \sqrt{3} - \text{Cot}^{-1}(-\sqrt{3})$
- $\text{Sin}^{-1}(\text{Sin} \frac{2\pi}{3})$
- $\text{Tan}^{-1}[2\text{Cos}(2\text{Sin}^{-1} \frac{1}{2})]$

Prove the following :

- $\text{Tan}^{-1}(\frac{2}{11}) + \text{Tan}^{-1}(\frac{7}{24}) = \text{Tan}^{-1}(\frac{1}{2})$
 - $2\text{Tan}^{-1}(\frac{1}{2}) - \text{Tan}^{-1}(\frac{1}{7}) = \text{Tan}^{-1}(\frac{1}{2})$
 - $2\text{Tan}^{-1}(\frac{1}{2}) - \text{Tan}^{-1}(\frac{1}{7}) = \text{Tan}^{-1}(\frac{31}{17})$
 - $2\text{Sin}^{-1}(\frac{3}{5}) = \text{Tan}^{-1}(\frac{24}{7})$
 - $\text{Sin}^{-1}(\frac{8}{17}) + \text{Sin}^{-1}(\frac{3}{5}) = \text{Tan}^{-1}(\frac{77}{36})$
 - If $4\text{Cos}^{-1}x + \text{Sin}^{-1}x = \pi$, find the value of x.
 - Find the principal value of $\text{Sin}^{-1}[\text{Cos}(\text{Sin}^{-1} \frac{\sqrt{3}}{2})]$
 - Find the value of $\text{Tan}[\text{Cos}^{-1}(\frac{4}{5}) + \text{Sin}^{-1}(\frac{2}{\sqrt{13}})]$
- {Hint : $\text{Sin}^{-1}x = \text{Tan}^{-1}(\frac{x}{\sqrt{1-x^2}})$, $\text{Cos}^{-1}x = \text{Tan}^{-1}(\frac{\sqrt{1-bx^2}}{x})$ }
- If $\text{Tan}^{-1}(x+1) + \text{Tan}^{-1}(x-1) = \text{Tan}^{-1}(\frac{8}{31})$. Find the value of x,
 - Prove that $\text{Cos}^{-1}(\frac{12}{13}) + \text{Sin}^{-1}(\frac{3}{5}) = \text{Sin}^{-1}(\frac{36}{65})$
 - Show that $\text{Tan}^{-1}(\frac{1}{8}) + \text{Tan}^{-1}(\frac{1}{7}) + \text{Tan}^{-1}(\frac{2}{3}) + \text{Tan}^{-1}(\frac{1}{8}) = \frac{\pi}{4}$
 - Prove that $\text{Sin}^{-1}x = \text{Tan}^{-1}(\frac{x}{\sqrt{1-x^2}})$ and $\text{Tan}^{-1}x - \text{Cot}^{-1}(\frac{1}{x})$
 - Hence find the value of $\text{Tan} \{ \text{Sin}^{-1}(\frac{3}{5}) + \text{Cot}^{-1}(\frac{2}{3}) \}$
 - If $\text{Tan}^{-1}(\frac{x-1}{x-2}) + \text{Tan}^{-1}(\frac{x+1}{x+2}) = \frac{\pi}{4}$. Find then value of x.

Miscellaneous Examples

1) Prove that $\tan^{-1} \sqrt{x} = \frac{1}{2} \text{Cos}^{-1} \left(\frac{1-x}{1+x} \right)$, $x \in [0,1]$

we have $\frac{1 - \tan^2 \theta}{1 + \tan^2 \theta} = \text{Cos} 2\theta$

take $x = \tan^2 \theta$, then $\tan \theta = \sqrt{x}$

R.H.S = $\frac{1}{2} \text{Cos}^{-1} \left(\frac{1-x}{1+x} \right)$

$\theta = \tan^{-1} \sqrt{x}$

= $\frac{1}{2} \text{Cos}^{-1} \left(\frac{1 - \tan^2 \theta}{1 + \tan^2 \theta} \right)$

= $\frac{1}{2} \text{Cos}^{-1} (\text{Cos} 2\theta)$

= $\frac{1}{2} \times 2\theta = \theta$

= $\tan^{-1} \sqrt{x}$

= L.H.S

2) Show that $3\text{Sin}^{-1} x = \text{Sin}^{-1} (3x - 4x^3)$, $x \in \left[\frac{1}{\Sigma}, \frac{1}{\Sigma} \right]$

we have $\text{Sin} 3x = 3\text{Sin} x - 4\text{Sin}^3 x$

R.H.S = $\text{Sin}^{-1} (3x - 4x^3)$

= $\text{Sin}^{-1} (\text{Sin} 3\theta)$

= 3θ

= $3\text{Sin}^{-1} x$

= L.H.S

3) If $\tan^{-1} \left(\frac{x-1}{x-2} \right) + \tan^{-1} \left(\frac{x+1}{x+2} \right) = \frac{\pi}{4}$ then find the value of x .

We have $\tan^{-1} x + \tan^{-1} y = \tan^{-1} \left(\frac{x+y}{1-xy} \right)$

= $\tan^{-1} \left(\frac{x-1}{x-2} \right) + \tan^{-1} \left(\frac{x+1}{x+2} \right)$

= $\tan^{-1} \left(\frac{\frac{x-1}{x-2} + \frac{x+1}{x+2}}{1 - \frac{(x-1)(x+1)}{x-2} \cdot \frac{(x+1)}{x+2}} \right)$

$$\begin{aligned}
&= \tan^{-1} \left(\frac{\frac{(x+2)(x-1) + (x+1)(x-2)}{(x+2)(x-2)}}{\frac{(x-2)(x+2)}{(x+2)(x-2)} - \frac{(x-1)(x+1)}{(x-2)(x+2)}} \right) \\
&= \tan^{-1} \left[\frac{x^2 + x - 2 + x^2 - x - 2}{x^2 - 4 - (x^2 - 1)} \right] \\
&= \tan^{-1} \left[\frac{2x^2 - 4}{x^2 - 4 - x^2 + 1} \right] \\
&= \tan^{-1} \left[\frac{2x^2 - 4}{-3} \right]
\end{aligned}$$

Given $\tan^{-1} \left(\frac{x-1}{x-2} \right) + \tan^{-1} \left(\frac{x+1}{x+2} \right) = \pi/4$

ie, $\tan^{-1} \left(\frac{2x^2 - 4}{-3} \right) = \pi/4$

$\therefore \frac{2x^2 - 4}{-3} = \tan \pi/4$

$\frac{2x^2 - 4}{-3} = 1$

$2x^2 - 4 = -3$

$2x^2 = 1$

$x^2 = 1/2, \quad x = \pm \frac{1}{\sqrt{2}}$

3) If $\sin \left(\sin^{-1} \frac{1}{5} + \cos^{-1} x \right) = 1$ then find the value of x .

Given $\sin \left(\sin^{-1} \frac{1}{5} + \cos^{-1} x \right) = 1$

$\sin^{-1} \left(\frac{1}{5} \right) + \cos^{-1} x = \sin^{-1} (1)$

$= \pi/2$

But we have $\sin^{-1} x + \cos^{-1} x = \pi/2$

Comparing $x = 1/5$

UNIT TEST

Marks : 20

Time : 45mts

- 1) Find the principal value of $\text{Sin}^{-1}\left(-\frac{1}{2}\right)$
- 2) $\tan^{-1}\sqrt{3} - \text{Sec}^{-1}(-2) = \dots\dots\dots\left(\pi, -\pi/3, \pi/3, 2\pi/3\right)$
- 3) $\text{Sin}\left(\tan^{-1}x\right)$ is equal to
- $$\left(\frac{x}{\sqrt{1-x^2}}, \frac{1}{\sqrt{1-x^2}}, \frac{1}{\sqrt{1+x^2}}, \frac{x}{\sqrt{1+x^2}}\right)$$
- 4) $\text{Sin}^{-1}x + \text{Cos}^{-1}(x) = \dots\dots\dots$, if $x \in [-1, 1]$
- 5) Find $\tan^{-1}\left(\tan\frac{7\pi}{6}\right)$ (1 score each)
- 6) Find the value of $\tan^{-1}(1) + \text{Cos}^{-1}\left(-\frac{1}{2}\right) + \text{Sin}^{-1}\left(-\frac{1}{2}\right)$ (2)
- 7) a) Show that $\text{Cos}^{-1}(1-2x^2) = 2\text{Sin}^{-1}x$ (2)
- b) Solve $\text{Sin}^{-1}(1-x) - 2\text{Sin}^{-1}x = \pi/2$ (3)
- c) Write in the simplest form $\tan^{-1}\left(\frac{\sqrt{1+x^2}-1}{x}\right)$, $x \neq 0$ (3)
- 8) a) Show that $\text{Sin}^{-1}\left(\frac{5}{13}\right) + \text{Cos}^{-1}\left(\frac{3}{5}\right) = \tan^{-1}\left(\frac{63}{16}\right)$ (3)
- b) Evaluate $\text{Cos}^{-1}\left(\text{Cos}\left(5\pi/3\right)\right)$ (1)
- c) Prove that $\tan^{-1}\left(\frac{2}{11}\right) + \tan^{-1}\left(\frac{7}{24}\right) = \tan^{-1}\left(\frac{1}{2}\right)$ (2)

Answers

- 1) We have $\text{Sin}\left(\pi/6\right) = 1/2$
 $\text{Sin}^{-1}\left(-1/2\right) = -\text{Sin}^{-1}\left(1/2\right)$
 $= -\pi/6$
- 2) $\tan\left(\pi/3\right) = \sqrt{3}$ $\text{Cos}\left(\pi/3\right) = 1/2$
 $\therefore \tan^{-1}\left(\sqrt{3}\right) = \pi/3$ $\text{Sec}\left(\pi/3\right) = 2$

$$\begin{aligned}
& \text{Sec}^{-1}(-2) = \pi - \text{Sec}^{-1}(2) \\
& = \pi - \frac{\pi}{3} \\
& = \frac{2\pi}{3} \\
& \therefore \tan^{-1}\sqrt{3} - \text{Sec}^{-1}(-2) \\
& = \frac{\pi}{3} + \frac{2\pi}{3} = \frac{3\pi}{3} = \pi
\end{aligned}$$

3) $\text{Sin}(\tan^{-1} x)$

Let $\tan^{-1} x = y \Rightarrow x = \tan y$

Then $\text{Sin}(\tan^{-1} x) = \text{Sin } y$

$$= \frac{x}{\sqrt{1+x^2}}$$

$$\text{Sin } y = \frac{x}{\sqrt{1+x^2}}$$

4) $\frac{\pi}{2}$

5) $\tan^{-1}\left(\tan\left(\frac{7\pi}{6}\right)\right) = \frac{7\pi}{6}$

$$\begin{aligned}
& \therefore \tan^{-1}\left(\tan\left(\pi + \frac{\pi}{6}\right)\right) = \tan^{-1}\left(\tan \frac{\pi}{6}\right) \\
& = \frac{\pi}{6} \in \left(-\frac{\pi}{2}, \frac{\pi}{2}\right)
\end{aligned}$$

6) We have $\tan^{-1}(1) = \frac{\pi}{4}$

$$\begin{aligned}
& \text{Cos}^{-1}\left(-\frac{1}{2}\right) = \pi - \text{Cos}^{-1}\left(\frac{1}{2}\right) \\
& = \pi - \frac{\pi}{3} \\
& = \frac{2\pi}{3}
\end{aligned}$$

$$\begin{aligned}
& \text{Sin}^{-1}\left(-\frac{1}{2}\right) = -\text{Sin}^{-1}\left(\frac{1}{2}\right) \\
& = \frac{\pi}{6}
\end{aligned}$$

$$\begin{aligned}
& \therefore \tan^{-1}(1) + \text{Cos}^{-1}\left(-\frac{1}{2}\right) + \text{Sin}^{-1}\left(-\frac{1}{2}\right) \\
& = \frac{\pi}{4} + \frac{2\pi}{3} + \frac{-\pi}{6} = \frac{3\pi}{12} + \frac{8\pi}{12} + \frac{-\pi}{12} \\
& = \frac{10\pi}{12} = \frac{5\pi}{6}
\end{aligned}$$

7. Prove that $\text{Cos}^{-1}(1-2x^2) = 2\text{Sin}^{-1}x$

a) We have $1 - \text{Cos}2x = 2\text{Sin}^2x$

$$\therefore \text{Cos}2x = 1 - 2\text{Sin}^2(x)$$

$$\begin{array}{l} \text{L.H.S} = \text{Cos}^{-1}(1-2x^2) \\ \quad = \text{Cos}^{-1}(1-2\text{Sin}^2\theta) \end{array} \quad \left| \begin{array}{l} \text{Take } x = \text{Sin}\theta \\ \Rightarrow \theta = \text{Sin}^{-1}x \end{array} \right.$$

$$= \text{Cos}^{-1}(\text{Cos}2\theta)$$

$$= 2\theta$$

$$= 2.\text{Sin}^{-1}x = \text{R.H.S}$$

b) Given $\text{Sin}^{-1}(1-x) - 2\text{Sin}^{-1}x = \pi/2$

$$\begin{array}{l} \text{Sin}^{-1}(1-x) = \pi/2 + 2\text{Sin}^{-1}x \\ \therefore 1-x = \text{Sin}\left(\pi/2 + 2\text{Sin}^{-1}x\right) \\ \quad = \text{Cos}(2\text{Sin}^{-1}x) \\ \quad = \text{Cos}\left(\text{Cos}^{-1}(1-2x^2)\right) \\ \quad = 1-2x^2 \end{array} \quad \left| \begin{array}{l} \text{Sin}\left(\pi/2 + \theta\right) \\ = \text{Cos}\theta \end{array} \right.$$

$$\begin{array}{l} 2x^2 - x = 0 \\ \Rightarrow x(2x-1) = 0 \end{array}$$

$$\Rightarrow x = 0 \text{ or } 2x = 1$$

$$\Rightarrow x = 0 \text{ or } x = 1/2$$

When $x = 1/2$

$$\text{L.H.S} = \text{Sin}^{-1}\left(1 - \frac{1}{2}\right) - 2\text{Sin}^{-1}\left(\frac{1}{2}\right)$$

$$= \text{Sin}^{-1}\left(\frac{1}{2}\right) - 2\text{Sin}^{-1}\left(\frac{1}{2}\right)$$

$$= -\text{Sin}^{-1}\left(\frac{1}{2}\right)$$

$$= -\pi/6 \neq \pi/2$$

$\therefore x = 1/2$ is not possible

hence $x = 0$

c) Take $x = \tan\theta \Rightarrow \theta = \tan^{-1}x$

$$\text{Tan}^{-1}\left(\frac{\sqrt{1+x^2}-1}{x}\right) = \tan^{-1}\left(\frac{\sqrt{1+\tan^2\theta}-1}{\tan\theta}\right)$$

$$\begin{aligned}
&= \tan^{-1}\left(\frac{\sqrt{\sec^2\theta - 1}}{\tan\theta}\right) = \tan^{-1}\left(\frac{\sqrt{\sec\theta - 1}}{\tan\theta}\right) \\
&= \tan^{-1}\left(\frac{\frac{1}{\cos\theta} - 1}{\frac{\sin\theta}{\cos\theta}}\right) = \tan^{-1}\left(\frac{1 - \cos\theta}{\sin\theta}\right) \\
&= \tan^{-1}\left(\frac{1 - \cos\theta}{\sin\theta}\right) = \tan^{-1}\left(\frac{2\sin^2\left(\frac{\theta}{2}\right)}{2\sin\left(\frac{\theta}{2}\right)\cos\left(\frac{\theta}{2}\right)}\right) \\
&= \tan^{-1}\left(\frac{\sin\left(\frac{\theta}{2}\right)}{\cos\left(\frac{\theta}{2}\right)}\right) = \tan^{-1}\left(\tan\left(\frac{\theta}{2}\right)\right) \\
&\quad \frac{\theta}{2} = \frac{\tan^{-1}x}{2}
\end{aligned}$$

8) a) Let $\sin^{-1}\left(\frac{5}{13}\right) = x$ and $\cos^{-1}\left(\frac{3}{5}\right) = y$

Then $\sin x = \frac{5}{13}$ $\cos y = \frac{3}{5}$

We want to Show that $\sin^{-1}\left(\frac{5}{13}\right) + \cos^{-1}\left(\frac{3}{5}\right) = \tan^{-1}\left(\frac{63}{16}\right)$

ie, to Show that $x + y = \tan^{-1}\left(\frac{63}{16}\right)$

ie, to Show that $\tan(x + y) = \frac{63}{16}$

Now $\tan(x + y) = \frac{\tan x + \tan y}{1 - \tan x \cdot \tan y}$

$$\tan(x + y) = \frac{\frac{5}{12} + \frac{4}{3}}{1 - \frac{5}{12} \cdot \frac{4}{3}} = \frac{\frac{5}{12} + \frac{16}{12}}{\frac{36}{36} - \frac{20}{36}}$$

$$= \frac{21}{\frac{16}{36}}$$

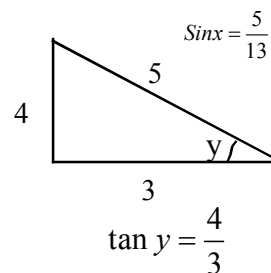
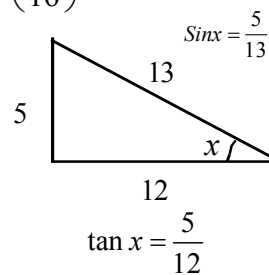

$$= \frac{21}{12} \times \frac{36}{16}$$

$$= \frac{63}{16}$$

Here the result.

b) $\text{Cos}^{-1}\left(\text{Cos}\frac{5\pi}{3}\right) = \frac{5\pi}{3} \notin (0, \pi)$

$$\text{Cos}^{-1}\left(\text{Cos}\left(2\pi - \frac{\pi}{3}\right)\right) = \text{Cos}^{-1}\left(\text{Cos}\frac{\pi}{3}\right) \left| \begin{array}{l} \\ \text{Cos}(2\pi - \theta) = \text{Cos}\theta \end{array} \right.$$

$$= \frac{\pi}{3} \in (0, \pi)$$

c) We have $\tan^{-1} x + \tan^{-1} y = \tan^{-1}\left(\frac{x+y}{1-xy}\right)$

$$\therefore \tan^{-1}\left(\frac{2}{11}\right) + \tan^{-1}\left(\frac{7}{24}\right) = \tan^{-1}\left(\frac{\frac{2}{11} + \frac{7}{24}}{1 - \frac{2}{11} \times \frac{7}{24}}\right)$$

$$= \tan^{-1}\left(\frac{\frac{2 \times 24 + 7 \times 11}{264}}{\frac{264}{264} - \frac{14}{264}}\right) = \tan^{-1}\left(\frac{48 + 77}{250}\right)$$

$$= \tan^{-1}\left(\frac{125}{250}\right) = \tan^{-1}\left(\frac{1}{2}\right)$$

3. MATRICES

Definition

A matrix is a rectangular array of numbers or functions. These numbers or functions are called elements of the matrix.

Consider following matrices,

$$A = \begin{bmatrix} 2 & 3 \\ 1 & 2 \end{bmatrix} \quad B = \begin{bmatrix} 1 \\ 2 \end{bmatrix} \quad C = \begin{bmatrix} 1 & -1 & 0 \\ -2 & 1 & 3 \end{bmatrix} \quad D = \begin{bmatrix} -5 & \frac{1}{2} \\ 4 & 2 \\ 0 & -3 \end{bmatrix}$$

$$E = \begin{bmatrix} 0 & -3 & -3 \\ 4 & 5 & 6 \\ 7 & 1 & 2 \end{bmatrix} \quad F = \begin{bmatrix} 2 & 0 & 0 \\ 4 & 5 & -3 \\ 6 & 1 & 2 \end{bmatrix} \quad G = \begin{bmatrix} 1 & 0 & 0 \\ 0 & 1 & 0 \\ 0 & 0 & 1 \end{bmatrix} \quad H = \begin{bmatrix} 2 & 0 & 0 \\ 0 & 2 & 0 \\ 0 & 0 & 2 \end{bmatrix}$$

Order of a matrix:

A matrix having m rows and n columns is called a matrix of order m×n. In the above example.

Order of the matrix A = 2x2

Order of the matrix B = 2x1

Order of the matrix C = 2x3

Qn. Write the order of other matrices.

General form of a matrix

$$A = \begin{bmatrix} a_{11} & a_{12} & a_{13} & \dots & a_{1n} \\ a_{21} & a_{22} & \dots & \dots & a_{2n} \\ \dots & \dots & \dots & \dots & \dots \\ \dots & \dots & \dots & \dots & \dots \\ a_{m1} & a_{m2} & \dots & \dots & a_{mn} \end{bmatrix}$$

Which is also represented by $(a_{ij})_{m \times n}$

Where a_{ij} is the j^{th} element of i^{th} row.

Qn: Construct a 3x2 matrix whose elements are given by $a_{ij} = \frac{i+j}{2}$

Ans: General form of a 3x2 matrix is $\begin{bmatrix} a_{11} & a_{12} \\ a_{21} & a_{22} \\ a_{31} & a_{32} \end{bmatrix}$

here $a_{11} = \frac{1+1}{2} = \frac{1}{2}$

$$a_{12} = \frac{3}{2} \quad a_{21} = \frac{3}{2} \quad a_{22} = 2 \quad a_{31} = 2 \quad a_{32} = \frac{5}{2}$$

hence the required matrix is $\begin{bmatrix} \frac{1}{2} & \frac{3}{2} \\ \frac{3}{2} & 2 \\ 2 & \frac{5}{2} \end{bmatrix}$

Qn: Construct a 2×3 matrix (a_{ij}) where $a_{ij} = |i - j|$

Qn: Construct a 3×3 matrix (a_{ij}) where $a_{ij} = \frac{(i + 2j)^2}{2}$

Types of matrices

Column matrix - Matrix having one column

$$\text{Eg:- } A = \begin{bmatrix} 1 \\ 2 \end{bmatrix} \quad B = \begin{bmatrix} 3 \\ 0 \\ 4 \end{bmatrix}$$

Row matrix - Matrix having one row.

$$\text{Eg:- } C = [5 \ 2] \quad D = [3 \ -2 \ -5]$$

Square matrix - No. of rows is equal to no. of columns.

$$\text{Eg:- } E = \begin{bmatrix} 3 & 4 \\ 1 & 2 \end{bmatrix} \quad F = \begin{bmatrix} 1 & -2 & 3 \\ 4 & -5 & -6 \\ -3 & 0 & 4 \end{bmatrix}$$

Diagonal matrix - A square matrix in which non diagonal elements are zero.

$$\text{Eg:- } G = \begin{bmatrix} 1 & 0 & 0 \\ 0 & 2 & 0 \\ 0 & 0 & 3 \end{bmatrix} \quad H = \begin{bmatrix} 2 & 0 \\ 0 & 4 \end{bmatrix}$$

Scalar matrix - A diagonal matrix is said to be scalar matrix if its diagonal elements are equal.

$$\text{Eg:- } J = \begin{bmatrix} 3 & 0 & 0 \\ 0 & 3 & 0 \\ 0 & 0 & 3 \end{bmatrix} \quad K = \begin{bmatrix} -2 & 0 \\ 0 & -2 \end{bmatrix}$$

Identity matrix - In a square matrix all its diagonal elements are 1 and all its non diagonal elements are zeros then it is an identity matrix which is usually denoted by I.

$$I_1 = [1] \quad I_2 = \begin{bmatrix} 1 & 0 \\ 0 & 1 \end{bmatrix} \quad I_3 = \begin{bmatrix} 1 & 0 & 0 \\ 0 & 1 & 0 \\ 0 & 0 & 1 \end{bmatrix}$$

Zero matrix - matrix with all its elements are zero.

$$L = \begin{bmatrix} 0 & 0 \\ 0 & 0 \end{bmatrix} \quad M = \begin{bmatrix} 0 & 0 & 0 \\ 0 & 0 & 0 \end{bmatrix}$$

Equality of Matrices

Two matrices are said to be equal if they are of same order and corresponding elements are equal.

Qn: $\begin{bmatrix} 2 & 3 \\ x & y \end{bmatrix} = \begin{bmatrix} 2 & 3 \\ 4 & 5 \end{bmatrix}$ Then find x & y

Ans: $x=4$ and $y=5$

Qn: Find the value of a, b, c & d from the equation

$$\begin{bmatrix} a-b & 2a+c \\ 2a-b & 3c+d \end{bmatrix} = \begin{bmatrix} -1 & 5 \\ 0 & 13 \end{bmatrix}$$

Ans: Equate the corresponding elements and find the values.

Addition of matrices: If $A = (a_{ij})$ $B = (b_{ij})$ then $A+B = (a_{ij}+b_{ij})$

Qn: Let $P = \begin{bmatrix} 3 & -2 \\ 4 & -3 \\ 5 & -6 \end{bmatrix}$ $Q = \begin{bmatrix} -3 & 1 \\ 4 & -5 \\ -2 & 1 \end{bmatrix}$ Then find $P+Q$

Ans: $P+Q = \begin{bmatrix} 3-3 & -2+1 \\ 4+4 & -3-5 \\ 5-2 & -6+1 \end{bmatrix} = \begin{bmatrix} 0 & -1 \\ 8 & -8 \\ 3 & -5 \end{bmatrix}$

Multiplication of a matrix by a scalar:

If $A = (a_{ij})$ $m \times n$ is a matrix and k is a scalar then $KA = (ka_{ij})$

Qn: $A = \begin{bmatrix} 1 & 2 & 3 \\ 2 & 3 & 1 \end{bmatrix}$ and $B = \begin{bmatrix} 3 & -1 & 3 \\ -1 & 0 & 2 \end{bmatrix}$ and then find $2A-B$

Ans: $2A = \begin{bmatrix} 2 & 4 & 6 \\ 4 & 6 & 2 \end{bmatrix}$ $B = \begin{bmatrix} 3 & -1 & 3 \\ -1 & 0 & 2 \end{bmatrix}$

$$\text{Then } 2A-B = \begin{bmatrix} 2-3 & 4+1 & 6-1 \\ 4+1 & 6-0 & 2-2 \end{bmatrix} = \begin{bmatrix} -1 & 5 & 3 \\ 5 & 6 & 0 \end{bmatrix}$$

Qn: Find X and Y if

$$X+Y = \begin{bmatrix} 7 & 0 \\ 2 & 5 \end{bmatrix} \quad X-Y = \begin{bmatrix} 3 & 0 \\ 0 & 3 \end{bmatrix}$$

Ans: $X+Y = \begin{bmatrix} 7 & 0 \\ 2 & 5 \end{bmatrix}$ - (1)

$$X-Y = \begin{bmatrix} 3 & 0 \\ 0 & 3 \end{bmatrix} \text{ - (2)}$$

$$(1)+(2) \Rightarrow 2X = \begin{bmatrix} 10 & 0 \\ 2 & 8 \end{bmatrix} \Rightarrow X = \begin{bmatrix} 5 & 0 \\ 1 & 4 \end{bmatrix}$$

$$(1)-(2) \Rightarrow 2Y = \begin{bmatrix} 4 & 0 \\ 2 & 2 \end{bmatrix} \Rightarrow Y = \begin{bmatrix} 2 & 0 \\ 1 & 1 \end{bmatrix}$$

Multiplication of Matrices

The product of two matrices A & B defined if the number of columns of A is equal to no. of rows of B.

If $A = (a_{ij})_{m \times p}$ & $B = (b_{ij})_{p \times n}$ Then

$$AB = (C_{ij})_{m \times n} \text{ Where } C_{ij} = \sum_{j=1}^p a_{ij} b_{jk}$$

ie, ij^{th} element of AB is product of i^{th} row of A & j^{th} column of B.

Qn: Find AB Where $A = \begin{bmatrix} 2 & 3 \\ 4 & 5 \\ 6 & 7 \end{bmatrix}$ and $B = \begin{bmatrix} 1 & -2 \\ 2 & 3 \end{bmatrix}$

Ans: $AB = \begin{bmatrix} 2+6 & 6+12 & 10+18 \\ 4+10 & 12+20 & 20+30 \\ 6+14 & 18+28 & 30+42 \end{bmatrix} = \begin{bmatrix} 8 & 18 & 28 \\ 14 & 32 & 50 \\ 20 & 46 & 72 \end{bmatrix}$

Qn: Find PQ where $P = \begin{bmatrix} 1 & 2 & -3 \\ 5 & 0 & 2 \\ 1 & -1 & 1 \end{bmatrix}$ $Q = \begin{bmatrix} 3 & -1 & 2 \\ 4 & 2 & 5 \\ 2 & 0 & 3 \end{bmatrix}$

$$PQ = \begin{bmatrix} 3+8-6 & -1+4+0 & 2+10-9 \\ 15+0+4 & 5+0+0 & 10+0+6 \\ 3-4+2 & -1-2+0 & 2-5+3 \end{bmatrix}$$

$$= \begin{bmatrix} 5 & 3 & 3 \\ 19 & -5 & 16 \\ 1 & -3 & 0 \end{bmatrix}$$

Qn: Complete the indicated product.

1) $\begin{bmatrix} a & b \\ -b & a \end{bmatrix} \begin{bmatrix} a & -b \\ b & a \end{bmatrix}$

$$2) \begin{bmatrix} 1 \\ 2 \\ 3 \end{bmatrix} [2 \ 3 \ 4]$$

$$3) \begin{bmatrix} 1 & -2 \\ 2 & 3 \end{bmatrix} \begin{bmatrix} 1 & 2 & 3 \\ 2 & 3 & 1 \end{bmatrix}$$

$$4) \begin{bmatrix} 2 & 3 & 4 \\ 3 & 4 & 5 \\ 4 & 5 & 6 \end{bmatrix} \begin{bmatrix} 1 & -3 & 5 \\ 0 & 2 & 4 \\ 3 & 0 & 5 \end{bmatrix}$$

$$5) \begin{bmatrix} 3 & -1 & 3 \\ -1 & 0 & 2 \end{bmatrix} \begin{bmatrix} 2 & -3 \\ 1 & 0 \\ 3 & 1 \end{bmatrix}$$

Qn: If $F(x) = \begin{bmatrix} \cos x & \sin x & 0 \\ \sin x & \cos x & 0 \\ 0 & 0 & 1 \end{bmatrix}$ Show that $F(x) \cdot F(y) = F(x+y)$

Ans: $F(x) = \begin{bmatrix} \cos x & \sin x & 0 \\ \sin x & \cos x & 0 \\ 0 & 0 & 1 \end{bmatrix}$ $F(y) = \begin{bmatrix} \cos y & \sin y & 0 \\ \sin y & \cos y & 0 \\ 0 & 0 & 1 \end{bmatrix}$

$$F(x) \cdot F(y) = \begin{bmatrix} \cos x \cos y - \sin x \sin y & -\cos x \sin y - \sin x \cos y & 0 \\ \sin x \cos y + \cos x \sin y & -\sin x \sin y + \cos x \cos y & 0 \\ 0 & 0 & 1 \end{bmatrix}$$

$$= \begin{bmatrix} \cos(x+y) & -\sin(x+y) & 0 \\ \sin(x+y) & \cos(x+y) & 0 \\ 0 & 0 & 1 \end{bmatrix}$$

$$= F(x+y)$$

Qn: $A = \begin{bmatrix} 3 & -2 \\ 4 & -2 \end{bmatrix}$ and $I = \begin{bmatrix} 1 & 0 \\ 0 & 1 \end{bmatrix}$ Find k so that $A^2 = kA - 2I$

Ans: $A^2 = AA = \begin{bmatrix} 3 & -2 \\ 4 & -2 \end{bmatrix} \begin{bmatrix} 3 & -2 \\ 4 & -2 \end{bmatrix} = \begin{bmatrix} 9-8 & -6+4 \\ 12-8 & -8+4 \end{bmatrix} = \begin{bmatrix} 1 & -2 \\ 4 & -4 \end{bmatrix}$

$$kA - 2I = \begin{bmatrix} 3k & -2k \\ 4k & -2k \end{bmatrix} - \begin{bmatrix} 2 & 0 \\ 0 & 2 \end{bmatrix} = \begin{bmatrix} 3k-2 & 4k \\ 4k & -2k-2 \end{bmatrix}$$

$$A^2 = kA - 2I \Rightarrow \begin{bmatrix} 3k-2 & -2k \\ 4k & -2k-2 \end{bmatrix} = \begin{bmatrix} 1 & -2 \\ 4 & -4 \end{bmatrix}$$

$$3k-2 = 1 \Rightarrow 3k = 3 \Rightarrow k=1$$

Transpose of a Matrix

If $A=(a_{ij})$, then the matrix obtained by interchanging rows and columns of the given matrix A is called transpose of A denoted by $A^T=(a_{ji})$.

Properties: $(A^T)^T = A$

$$(A+B)^T = A^T + B^T$$

$$(KA)^T = KA^T$$

$$(AB)^T = B^T A^T$$

Qn: If $A = \begin{bmatrix} 3 & 4 & 5 \\ 6 & 7 & 8 \end{bmatrix}$ Find A^T

$$A^T = \begin{bmatrix} 3 & 6 \\ 4 & 7 \\ 5 & 8 \end{bmatrix}$$

Symmetric and Skew symmetric matrices.

A matrix is said to be symmetric if $A^T=A$ and is said to be skew symmetric if $A^T=-A$

Eg:- $A = \begin{bmatrix} 1 & 2 \\ 2 & 3 \end{bmatrix}$ is symmetric

$B = \begin{bmatrix} 1 & -3 & -4 \\ -3 & 5 & 6 \\ -4 & 6 & 7 \end{bmatrix}$ is symmetric

$C = \begin{bmatrix} 0 & 1 \\ -1 & 2 \end{bmatrix}$ is skew symmetric

$D = \begin{bmatrix} 0 & 1 & 2 \\ -1 & 0 & 4 \\ -2 & -4 & 0 \end{bmatrix}$ is skew symmetric

Result: For any square matrix A , $A+A^T$ is symmetric and $A-A^T$ is skew symmetric.

Proof: $(A+A^T)^T = A^T+(A^T)^T = A^T+A = A+A^T$

$\therefore A+A^T$ is symmetric

$$(A-A^T)^T = A^T-(A^T)^T = A^T-A = -(A-A^T)$$

$\therefore A-A^T$ is skew symmetric

Diagonal elements of a skew symmetric matrices are all zero.

A skew symmetric matrix is not a diagonal matrix.

UNIT TEST

Time : 40 mts

Max.Marks : 20

1) Is $A = \begin{bmatrix} 12 & 2 & 3 \\ 34 & 4 & 8 \end{bmatrix}$ and $B = \begin{bmatrix} 1 & 0 \\ 0 & 1 \end{bmatrix}$ then $AB = \dots\dots\dots$ (1)

2) $A = \begin{bmatrix} 0 & 1 & 5 \\ -1 & x-1 & -6 \\ -5 & 6 & 0 \end{bmatrix}$ is a skew symmetric matrix, then the value of $x = \dots\dots\dots$ (1)

3) $A = \begin{bmatrix} 1 & 2 & 3 \\ 6 & 7 & 8 \end{bmatrix}$, $B = \begin{bmatrix} 2 \\ 3 \\ 4 \end{bmatrix}$ then order of $AB = \dots\dots\dots$ (1)

4) If $A = \begin{bmatrix} \cos\alpha & -\sin\alpha \\ \sin\alpha & \cos\alpha \end{bmatrix}$ and $A+A^T = I$, then the value $\alpha = \dots\dots\dots$ (1)

5) If A, B are symmetric matrices of same order, then $AB - BA$ is $\dots\dots\dots$
 (A - Skew symmetric matrix, B - Symmetric matrix, C - Zero Matrix, D-Identity matrix) (1)

6) Consider 2x2 matrix $A = [a_{ij}]$ where $a_{ij} = |2i - 3j|$
 a) Write A (2)
 b) Find $A+A^1$ (1)

7) Consider $A = \begin{bmatrix} 3 & 3 & -1 \\ -2 & -2 & 1 \\ -4 & -5 & 2 \end{bmatrix}$
 a) Using the Matrix A, form Symmetric and Skew Symmetric Matrices. (2)
 b) Express A as sum of symmetric and skew symmetric matrices (2)

8) a) If A is a square matrix, such that $A^2=A$ then $(I+A)^3-7A$ is equal to $\dots\dots\dots$ (1)
 b) Let $A = \begin{bmatrix} 3 & 1 \\ -1 & 2 \end{bmatrix}$
 (i) Find A^2 and $5A$ (2)
 (ii) Show that $A^2-5A+7I=0$ (1)

9) Find the inverse of the matrix $A = \begin{bmatrix} 1 & 2 \\ -2 & -1 \end{bmatrix}$, using elementary row operation.

10) For the matrices A and B verify that $(AB)^1 = B^1.A^1$. Where

$A = \begin{bmatrix} 1 \\ -4 \\ 3 \end{bmatrix}$, $B = [-1 \ 2 \ 1]$ (2)

Answers

- 1) We have $A.I. = I, \forall A$ (Ans: A)
Here $AB = A$
- 2) Since A is Skew Symmetric matrix, diagonal elements are all zero.

$$\therefore x - 1 = 0$$

$$x = 1$$

- 3) Order of $A = 2 \times 3$, order of $B = 3 \times 1$

$$2 \times \boxed{3 \ 3} \times 1$$

$$\text{Order of } AB = 2 \times 1$$

4) $A = \begin{bmatrix} \cos \alpha & -\sin \alpha \\ \sin \alpha & \cos \alpha \end{bmatrix}$

$$A^1 = \begin{bmatrix} \cos \alpha & \sin \alpha \\ -\sin \alpha & \cos \alpha \end{bmatrix}$$

$$\text{Given } A + A^1 = A^1 = \begin{bmatrix} 1 & 0 \\ 0 & 1 \end{bmatrix}$$

$$\text{First element in Ist row of } A + A^1 = \cos \alpha + \cos \alpha$$

$$= 2 \cos \alpha$$

$$= 2 \cos \alpha = 1$$

$$= \cos \alpha = \frac{1}{2} \Rightarrow \alpha = \frac{\pi}{3}$$

- 5) Given $A^1 = A$, $B^1 = B$
 $(AB - BA)^T = (AB)^T - (BA)^T$
 $= B^T A^T - A^T B^T$
 $= BA - AB$
 $= -(AB - BA)$

$\therefore AB - BA$ is Skew Symmetric.

- 6) a) Given $A = [a_{ij}]_{2 \times 2}$

$$A = \begin{bmatrix} a_{11} & a_{12} \\ a_{21} & a_{22} \end{bmatrix}$$

$$\text{Given } a_{ij} = |2i - 3j|$$

$$a_{11} = |2 \times 1 - 3 \times 1| = |2 - 3| = 1$$

$$a_{12} = |2 \times 1 - 3 \times 2| = |2 - 6| = 4$$

$$a_{21} = |2 \times 2 - 3 \times 1| = |4 - 3| = 1$$

$$a_{22} = |2 \times 2 - 3 \times 2| = |4 - 6| = 2$$

$$\therefore A = \begin{bmatrix} 1 & 4 \\ 1 & 2 \end{bmatrix}$$

$$\text{b) } A^1 = \begin{bmatrix} 1 & 1 \\ 4 & 2 \end{bmatrix}$$

$$A + A^1 = \begin{bmatrix} 1 & 4 \\ 1 & 2 \end{bmatrix} + \begin{bmatrix} 1 & 1 \\ 4 & 2 \end{bmatrix}$$

$$= \begin{bmatrix} 1+1 & 4+1 \\ 1+4 & 2+2 \end{bmatrix} = \begin{bmatrix} 2 & 5 \\ 5 & 4 \end{bmatrix}$$

$$7) \text{ a) Given } A = \begin{bmatrix} 3 & 3 & -1 \\ -2 & -2 & 1 \\ -4 & -5 & 2 \end{bmatrix}$$

$$A^1 = \begin{bmatrix} 3 & -2 & -4 \\ 3 & -2 & -5 \\ -1 & 1 & 2 \end{bmatrix}$$

$$\text{let } P = A + A^1 = \begin{bmatrix} 6 & 1 & -5 \\ 1 & -4 & -4 \\ -5 & -4 & 4 \end{bmatrix}$$

$$P^1 = \begin{bmatrix} 6 & 1 & -5 \\ 1 & -4 & -4 \\ -5 & -4 & 4 \end{bmatrix} = P$$

$\therefore P$ is Symmetric

$$Q = A - A^1 = \begin{bmatrix} 3 & 3 & -1 \\ -2 & -2 & 1 \\ -4 & -5 & 2 \end{bmatrix} - \begin{bmatrix} 3 & -2 & -4 \\ 3 & -2 & -5 \\ -1 & 1 & 2 \end{bmatrix}$$

$$= \begin{bmatrix} 0 & 5 & 3 \\ -5 & 0 & 6 \\ -3 & -6 & 0 \end{bmatrix}$$

$$\text{Hence } Q^1 = \begin{bmatrix} 0 & -5 & -3 \\ 5 & 0 & -6 \\ 3 & 6 & 0 \end{bmatrix} = - \begin{bmatrix} 0 & 5 & 3 \\ -5 & 0 & 6 \\ -3 & -6 & 0 \end{bmatrix} = -Q$$

$\therefore Q$ is Skew Symmetric.

b) We have $A = \frac{A+A^1}{2} + \frac{A-A^1}{2} = \frac{P}{2} + \frac{Q}{2}$

$$\frac{P}{2} = \frac{1}{2} \begin{bmatrix} 6 & 1 & -5 \\ 1 & -4 & -4 \\ -5 & -4 & 4 \end{bmatrix} = \begin{bmatrix} \frac{6}{2} & \frac{1}{2} & \frac{-5}{2} \\ \frac{1}{2} & \frac{4}{2} & \frac{-4}{2} \\ \frac{-5}{2} & \frac{-4}{2} & \frac{4}{2} \end{bmatrix}$$

$$= \begin{bmatrix} 3 & \frac{1}{2} & \frac{-5}{2} \\ \frac{1}{2} & -2 & -2 \\ \frac{-5}{2} & -2 & 2 \end{bmatrix} = \frac{Q}{2} = \frac{1}{2} Q = \begin{bmatrix} 0 & \frac{5}{2} & \frac{3}{2} \\ \frac{-5}{2} & 0 & \frac{6}{2} \\ \frac{-3}{2} & \frac{-6}{2} & 0 \end{bmatrix}$$

$$A = \begin{bmatrix} 3 & \frac{1}{2} & \frac{-5}{2} \\ \frac{1}{2} & -2 & -2 \\ \frac{-5}{2} & -2 & 2 \end{bmatrix} + \begin{bmatrix} 0 & \frac{5}{2} & \frac{3}{2} \\ \frac{-5}{2} & 0 & 3 \\ \frac{-3}{2} & -3 & 0 \end{bmatrix}$$

8) a) $(I+A)^3 - 7A = I^3 + 3I^2A + 3IA^2 + A^3 - 7A$
 $= I + 3A + 3A^2 + A^3 - 7A$
 $= I + 3A + 3A + A^2 - 7A$
 $= I + 3A + 3A + A - 7A$
 $= I$

b) $A = \begin{bmatrix} 3 & 1 \\ -1 & 2 \end{bmatrix}$

i) $A^2 = \begin{bmatrix} 3 & 1 \\ -1 & 2 \end{bmatrix} \begin{bmatrix} 3 & 1 \\ -1 & 2 \end{bmatrix}$
 $= \begin{bmatrix} 3 \times 3 + 1 \times -1 & 3 \times 1 + 1 \times 2 \\ -1 \times 3 + 2 \times -1 & -1 \times 1 + 2 \times 2 \end{bmatrix}$
 $= \begin{bmatrix} -1 & 3+2 \\ -3 & -1+4 \end{bmatrix} = \begin{bmatrix} 8 & 5 \\ -5 & 3 \end{bmatrix}$

$$5A = 5 \begin{bmatrix} 3 & 1 \\ -1 & 2 \end{bmatrix} = \begin{bmatrix} 5 \times 3 & 5 \times 1 \\ 5 \times -1 & 5 \times 2 \end{bmatrix}$$

$$= \begin{bmatrix} 15 & 5 \\ -5 & 10 \end{bmatrix}$$

$$\text{ii) } 7I = 7 \begin{bmatrix} 1 & 0 \\ 0 & 1 \end{bmatrix} = \begin{bmatrix} 7 \times 1 & 7 \times 0 \\ 0 \times 7 & 7 \times 1 \end{bmatrix}$$

$$= \begin{bmatrix} 7 & 0 \\ 0 & 7 \end{bmatrix}$$

$$= A^2 - 5A + 7I = \begin{bmatrix} 8 & 5 \\ -5 & 3 \end{bmatrix} - \begin{bmatrix} 15 & 5 \\ -5 & 10 \end{bmatrix} + \begin{bmatrix} 7 & 0 \\ 0 & 7 \end{bmatrix}$$

$$= \begin{bmatrix} -7 & 0 \\ 0 & -7 \end{bmatrix} + \begin{bmatrix} 7 & 0 \\ 0 & 7 \end{bmatrix}$$

$$= \begin{bmatrix} 0 & 0 \\ 0 & 0 \end{bmatrix}$$

9) Write $A = IA$

$$\text{ie, } \begin{bmatrix} 1 & 2 \\ 2 & -1 \end{bmatrix} = \begin{bmatrix} 1 & 0 \\ 0 & 1 \end{bmatrix} A$$

$$R_2 \rightarrow R_2 - 2R_1$$

$$= \begin{bmatrix} 1 & 2 \\ 0 & -5 \end{bmatrix} = \begin{bmatrix} 1 & 0 \\ -2 & 1 \end{bmatrix} A$$

$$R_2 \rightarrow \frac{R_2}{-5}$$

$$\begin{bmatrix} 1 & 2 \\ 0 & 1 \end{bmatrix} = \begin{bmatrix} 1 & 0 \\ \frac{2}{5} & \frac{-1}{5} \end{bmatrix} A$$

$$R_1 \rightarrow 2R_2$$

$$\begin{bmatrix} 1 & 0 \\ 0 & 1 \end{bmatrix} = \begin{bmatrix} 1 - \frac{4}{5} & \frac{2}{5} \\ \frac{2}{5} & \frac{-1}{5} \end{bmatrix} A$$

$$= \begin{bmatrix} \frac{1}{5} & \frac{2}{5} \\ \frac{2}{5} & \frac{-1}{5} \end{bmatrix} A$$

$$\therefore A^{-1} = \begin{bmatrix} \frac{1}{5} & \frac{2}{5} \\ \frac{2}{5} & \frac{-1}{5} \end{bmatrix}$$

$$10) \quad A^{-1} = [1 \quad -4 \quad 3], \quad B^{-1} = \begin{bmatrix} -1 \\ 2 \\ 1 \end{bmatrix}$$

$$AB = \begin{bmatrix} 1 \\ -4 \\ 3 \end{bmatrix} \begin{bmatrix} -1 & 2 & 1 \end{bmatrix}$$

$$= \begin{bmatrix} 1x-1 & 1x2 & 1x1 \\ -4x-1 & -4x2 & -4x1 \\ 3x-1 & 3x2 & 3x1 \end{bmatrix}$$

$$= \begin{bmatrix} -1 & 2 & 1 \\ 4 & -8 & -4 \\ -3 & 6 & 3 \end{bmatrix}$$

$$(AB)^{-1} = \begin{bmatrix} -1 & 4 & -3 \\ 2 & -8 & 6 \\ 1 & -4 & 3 \end{bmatrix} \dots(1)$$

$$B^{-1}A^{-1} = \begin{bmatrix} -1 \\ 2 \\ 1 \end{bmatrix} \begin{bmatrix} 1 & -4 & 3 \end{bmatrix}$$

$$= \begin{bmatrix} -1 & 4 & -3 \\ 2 & -8 & 6 \\ 1 & -4 & 3 \end{bmatrix} \dots\dots(2)$$

From (1) and (2) $(AB)^{-1} = B^{-1}A^{-1}$

4. DETERMINANTS

ആമുഖം

സംഖ്യകളുടെ വിന്യാസമാണ് മാട്രിക്സ് എന്ന് നിങ്ങൾ മനസ്സിലാക്കി. എന്നാൽ സമചതുരാകൃതിയിൽ വിന്യസിച്ചിരിക്കുന്ന ഒരു മാട്രിക്സുമായി ബന്ധപ്പെടുത്തുന്ന സംഖ്യയാണ് ഡിറ്റർമിനന്റ്.

A എന്ന സമചതുരാകൃതിയിലുള്ള മാട്രിക്സിന്റെ ഡിറ്റർമിനന്റിനെ $|A|$ കൊണ്ടോ $\det(A)$ കൊണ്ടോ സൂചിപ്പിക്കുന്നു.

2x2 മാട്രിക്സിന്റെ ഡിറ്റർമിനന്റ്

$$A = \begin{bmatrix} a & b \\ c & d \end{bmatrix} \text{ എങ്കിൽ } |A| = ad - bc$$

3x3 മാട്രിക്സിന്റെ ഡിറ്റർമിനന്റ്

$$A = \begin{bmatrix} a & b & c \\ d & e & f \\ g & h & a \end{bmatrix} \text{ എങ്കിൽ}$$

$$|A| = a \begin{bmatrix} e & f \\ h & a \end{bmatrix} - b \begin{bmatrix} d & f \\ g & a \end{bmatrix} + c \begin{bmatrix} d & e \\ g & h \end{bmatrix}$$

സംഖ്യകളുടെ ക്രിയകളുമായി ബന്ധപ്പെട്ട ചില സൂചനകൾ

സങ്കലനം

$$+ve + +ve = +ve$$

$$-ve + -ve = -ve$$

വിപരീത ചിഹ്നങ്ങളുള്ള സംഖ്യകൾ കൂട്ടുമ്പോൾ കേവലവില വലുതിൽ നിന്ന് കേവലവില ചെറുത് കുറച്ച് കേവലവില വലുതിന്റെ ചിഹ്നം എഴുതുക.

$$\text{ഉദാ:- } -8+2 = -(8-2) = -6$$

$$9+ -4 = 9-4 = 5$$

വ്യവകലനം

കുറക്കേണ്ട സംഖ്യയുടെ ചിഹ്നം മാറ്റി കൂട്ടുക

$$\text{ഉദാ:- } 10-2 = 10+2 = 12$$

$$(-4) - (-9) = -4+9=9-4 = 5$$

ഗുണനം

$$(+ve) \times (+ve) = +ve$$

$$(+ve) \times (-ve) = -ve$$

$$(-ve) \times (+ve) = -ve$$

$$(-ve) \times (-ve) = +ve$$

ഹരണം

$$\frac{+ve}{+ve} = +ve$$

$$\frac{+ve}{-ve} = -ve$$

$$\frac{-ve}{+ve} = -ve$$

$$\frac{-ve}{-ve} = +ve$$

ഭിന്നസംഖ്യകൾ

$\frac{a}{b}$ എന്ന രൂപത്തിലുള്ള സംഖ്യകളാണ് ഭിന്നസംഖ്യകൾ.

(a യും b യും പൂർണ്ണസംഖ്യകളായിരിക്കണം)

പൂർണ്ണസംഖ്യയും ഭിന്നസംഖ്യയാണ്.

ഉദാ:- $5 = \frac{5}{1}$

ക്രിയകൾ

സങ്കലനം: ഛേദം സമാനമാണെങ്കിൽ ഉത്തരത്തിന്റെ ഛേദം പൊതുവായ ഛേദവും അംശം അംശങ്ങളുടെ തുകയും.

ഉദാ:- $\frac{2}{7} + \frac{4}{7} = \frac{2+4}{7} = \frac{6}{7}$

ഛേദം വ്യത്യസ്തങ്ങളാണെങ്കിൽ

$$\frac{a}{b} + \frac{c}{d} = \frac{ad+bc}{bd} \text{ (ക്രോസ് ഗുണനം)}$$

ഉദാ:- $\frac{4}{9} + \frac{5}{11} = \frac{(4)(11)+(5)(9)}{(9)(11)} = \frac{44+45}{99} = \frac{89}{99}$

ഗുണനം

അംശങ്ങൾ തമ്മിലും ഛേദങ്ങൾ തമ്മിലും ഗുണിക്കുക.

$$\frac{a}{b} \times \frac{c}{d} = \frac{a.c}{b.d}$$

ഹരണം

അംശവും ഛേദവും പരസ്പരം മാറ്റി ഗുണിക്കുക

$$\frac{a}{b} \div \frac{c}{d} = \frac{a}{b} \times \frac{d}{c} = \frac{ad}{bc}$$

ഒരു ത്രികോണത്തിന്റെ വിസ്തീർണ്ണം

ഒരു ത്രികോണത്തിന്റെ ശീർഷങ്ങൾ (vertices) $(x_1, y_1), (x_2, y_2), (x_3, y_3)$ എങ്കിൽ വിസ്തീർണ്ണം

$$= \frac{1}{2} \begin{vmatrix} x_1 & y_1 & 1 \\ x_2 & y_2 & 1 \\ x_3 & y_3 & 1 \end{vmatrix}$$

മൈനറും കോഫാക്ടറും (Minor and cofactor)

a_{ij} എന്ന പദത്തിന്റെ മൈനറിനെ M_{ij} കൊണ്ടു സൂചിപ്പിക്കുന്നു. a_{ij} എന്ന പദത്തിന്റെ കോഫാക്ടറിനെ A_{ij} കൊണ്ടു സൂചിപ്പിക്കുന്നു.

M_{ij} കിട്ടാൻ a_{ij} നിൽക്കുന്ന row യും column ഉം ഒഴിവാക്കിക്കിട്ടുന്ന മാട്രിക്സിന്റെ ഡിറ്റർമിനന്റ് കണ്ടാൽ മതി.

A_{ij} കിട്ടാൻ $A_{ij} = (-1)^{i+j} M_{ij}$ എന്ന formula ഉപയോഗിക്കുക.

സൂചന: (-1) ന്റെ കൃതി ഒറ്റസംഖ്യയാണെങ്കിൽ -1 ഉം ഇരട്ടസംഖ്യയാണെങ്കിൽ 1 ഉം ആണ്.

മാട്രിക്സിന്റെ അഡ്ജോയിന്റ്

A_{ij} എന്നത് a_{ij} എന്ന പദത്തിന്റെ കോഫാക്ടർ എങ്കിൽ,

$$A = \begin{bmatrix} a_{11} & a_{12} & a_{13} \\ a_{21} & a_{22} & a_{23} \\ a_{31} & a_{32} & a_{33} \end{bmatrix} \text{ എന്ന മാട്രിക്സിന്റെ അഡ്ജോയിന്റ്}$$

$$\text{adj } A = \begin{bmatrix} A_{11} & A_{21} & A_{31} \\ A_{12} & A_{22} & A_{32} \\ A_{13} & A_{23} & A_{33} \end{bmatrix}$$

സൂചന: A യിലെ ഒന്നാമത്തെ row യിലെ പദങ്ങളുടെ cofactor കണ്ട് column ആയിട്ടാണ് adjA കിട്ടാൻ എഴുതേണ്ടത്.

മാട്രിക്സിന്റെ ഇൻവേഴ്സ് (inverse) കാണാനുള്ള formula.

$$|A| \neq 0 \text{ എങ്കിൽ } A^{-1} = \frac{1}{|A|} \text{adj}A$$

System of linear equation നിർധാരണം ചെയ്യുന്നവിധം

താഴെപറയുന്ന Sysytem of linear equation പരിഗണിക്കുക.

$$a_1 x + b_1 y = c_1$$

$$a_2 x + b_2 y = c_2$$

ഇതിനെ മാട്രിക്സ് രൂപത്തിൽ ഇങ്ങനെ എഴുതാം.

$$\begin{bmatrix} a_1 & b_1 \\ a_2 & b_2 \end{bmatrix} \begin{bmatrix} x \\ y \end{bmatrix} = \begin{bmatrix} c_1 \\ c_2 \end{bmatrix}$$

$\begin{bmatrix} a_1 & b_1 \\ a_2 & b_2 \end{bmatrix}$ നെ A എന്നും $\begin{bmatrix} x \\ y \end{bmatrix}$ യെ X എന്നും $\begin{bmatrix} c_1 \\ c_2 \end{bmatrix}$ യെ B എന്നും വിളിച്ചാൽ,

$AX=B$ എന്ന് കിട്ടും.

A^{-1} കണ്ട് A^{-1} നെ B കൊണ്ട് ഗുണിക്കുക.

$A^{-1}B$ എന്ന മാട്രിക്സ് $\begin{bmatrix} x_1 \\ y_2 \end{bmatrix}$ എന്ന രൂപത്തിൽ ആയിരിക്കും.

അപ്പോൾ $X = \begin{bmatrix} x \\ y \end{bmatrix} = \begin{bmatrix} x_1 \\ y_2 \end{bmatrix}$ എന്ന് കിട്ടും.

അതുകൊണ്ട് $x=x_1$ എന്നും $y=y_1$ എന്നും കിട്ടുന്നു.

$|A| \neq 0$ എങ്കിൽ മാത്രമേ ഈ രീതിയിൽ നിർധാരണം ചെയ്യാൻ കഴിയുകയുള്ളൂ.

ഉദാ:- Evaluate the determinant $\begin{vmatrix} 3 & -4 & 5 \\ 1 & 1 & -2 \\ 2 & 3 & 1 \end{vmatrix}$

Solution

$$\begin{vmatrix} 3 & -4 & 5 \\ 1 & 1 & -2 \\ 2 & 3 & 1 \end{vmatrix} = 3 \begin{vmatrix} 1 & -2 \\ 3 & 1 \end{vmatrix} - 4 \begin{vmatrix} 1 & -2 \\ 2 & 1 \end{vmatrix} + 5 \begin{vmatrix} 1 & 1 \\ 2 & 3 \end{vmatrix}$$

(Expansion along 1st Row)

$$\begin{aligned} &= [1(1) - 3(-2)] + 4[1(1) - 2(-2)] + 5[1(3) - 2(1)] \\ &= 3[1 - (-6)] + 4[1 - (-4)] + 5[3 - 2] \\ &= 3[1 + 6] + 4[1 + 5] + 5[3 - 2] \\ &= 3(7) + 4(6) + 5(1) \\ &= 21 + 24 + 5 \\ &= 50 \end{aligned}$$

Find the area of the triangle with vertices at the point given in (1,0), (6,0), (4,3)

Solution

Area of the triangle with vertices (x_1, y_1) , (x_2, y_2) and (x_3, y_3)

$$\text{is } \Delta = \frac{1}{2} \begin{vmatrix} x_1 & y_1 & 1 \\ x_2 & y_2 & 1 \\ x_3 & y_3 & 1 \end{vmatrix}$$

$$\begin{aligned} \text{Here } (x_1, y_1) &= (1, 0) \\ (x_2, y_2) &= (6, 0) \\ (x_3, y_3) &= (4, 3) \end{aligned}$$

$$\therefore \text{Area}\Delta = \frac{1}{2} \begin{vmatrix} 1 & 0 & 1 \\ 6 & 0 & 1 \\ 4 & 3 & 1 \end{vmatrix}$$

$$\begin{aligned} \frac{1}{2} &= \{1(0-3) - 0 + 1(18-0)\} \\ &= \frac{1}{2} \{-3 + 18\} \\ &= \frac{1}{2}(15) \\ &= \frac{15}{2} \end{aligned}$$

Show that the points

A(a,b+c), B(b, c+a), C(c, a+b) are collinear.

Solution

Three points (x_1, y_1) , (x_2, y_2) and (x_3, y_3) are collinear

$$\text{if } \begin{vmatrix} x_1 & y_1 & 1 \\ x_2 & y_2 & 1 \\ x_3 & y_3 & 1 \end{vmatrix} = 0$$

Here $(x_1, y_1) = (a, b+c)$

$(x_2, y_2) = (b, c+a)$

$(x_3, y_3) = (c, a+b)$

$$\begin{vmatrix} x_1 & y_1 & 1 \\ x_2 & y_2 & 1 \\ x_3 & y_3 & 1 \end{vmatrix} = \begin{vmatrix} a & b+c & 1 \\ b & c+a & 1 \\ c & a+b & 1 \end{vmatrix}$$

$$= \begin{vmatrix} a+b+c & b+c & 1 \\ b+c+a & c+a & 1 \\ c+a+b & a+b & 1 \end{vmatrix} \quad C_1 \rightarrow C_1 + C_2$$

$$= (a+b+c) \begin{vmatrix} 1 & b+c & 1 \\ 1 & c+a & 1 \\ 1 & a+b & 1 \end{vmatrix}$$

$= (a+b+c) \times 0$ ($C_1 = C_2$) ആയതുകൊണ്ട്

$= 0 \therefore$ The given points are collinear.

Find the equation of the line joining (1,2) and (3,6) using determinants.

Solution

Let (x, y) be any point in the line joining (1,2) and (3,6) then,

$$\begin{vmatrix} x & y & 1 \\ 1 & 2 & 1 \\ 3 & 6 & 1 \end{vmatrix} = 0$$

ie, $x(2-6) - y(1-3) + 1(6-6) = 0$

ie, $x(-4) - y(-2) + 0 = 0$

ie, $-4x + 2y = 0$

ie, $2x - y = 0$

പരിശീലനം

I Find the determinant of the following matrices.

1. $\begin{vmatrix} 1 & 2 \\ 3 & 4 \end{vmatrix}$

2. $\begin{vmatrix} -1 & -2 \\ 3 & 5 \end{vmatrix}$

3. $\begin{vmatrix} -1 & 4 \\ 6 & -5 \end{vmatrix}$

4. $\begin{vmatrix} 1 & -1 & 2 \\ 3 & 4 & 6 \\ 2 & -5 & 7 \end{vmatrix}$

5. $\begin{vmatrix} 0 & 1 & 3 \\ -3 & -2 & 5 \\ 2 & -1 & 1 \end{vmatrix}$

II Find the areas of the triangle whose vertices are given as

a) (1, 2), (1, 4), (2, 6)

b) (0, 0), (1, 1), (2, 2)

c) (-1, 1), (-2, 4), (0, 5)

III Find the equation of the line joining (3,11) and (9,3)

Eg:- Write the minor and cofactors of the elements of the determinants $\begin{vmatrix} 2 & -4 \\ 0 & 3 \end{vmatrix}$

$$\begin{aligned} M_{11} &= 3 & A_{11} &= (-1)^{1+1} M_{11} = 3 \\ M_{12} &= 0 & A_{12} &= (-1)^{1+2} M_{12} = 0 \\ M_{21} &= -4 & A_{21} &= (-1)^{2+1} M_{21} = (-1)(-4) = 4 \\ M_{22} &= 2 & A_{22} &= (-1)^{2+2} M_{22} = 2 \end{aligned}$$

Eg:- Write the minors and cofactors of the elements of the determinant.

$$\begin{vmatrix} 1 & 0 & 4 \\ 3 & 5 & -1 \\ 0 & 1 & 2 \end{vmatrix}$$

$$M_{11} = \begin{vmatrix} 5 & -1 \\ 1 & 2 \end{vmatrix} = 10 - (-1) = 11$$

$$A_{11} = (-1)^{1+1} M_{11} = 11$$

$$M_{12} = \begin{vmatrix} 3 & -1 \\ 0 & 2 \end{vmatrix} = 6 - 0 = 6$$

$$A_{12} = (-1)^{1+2} M_{12} = (-1)6 = -6$$

$$M_{13} = \begin{vmatrix} 3 & 5 \\ 0 & 1 \end{vmatrix} = 3 - 0 = 3$$

$$A_{13} = (-1)^{1+3} M_{13} = 3$$

$$M_{21} = \begin{vmatrix} 0 & 4 \\ 1 & 2 \end{vmatrix} = 0 - 4 = -4$$

$$A_{21} = (-1)^{2+1} M_{21} = (-1)(-4) = 4$$

$$M_{22} = \begin{vmatrix} 0 & 4 \\ 1 & 2 \end{vmatrix} = 2 - 0 = 2$$

$$A_{22} = (-1)^{2+2} M_{22} = (1)(2) = 2$$

$$M_{23} = \begin{vmatrix} 1 & 0 \\ 0 & 1 \end{vmatrix} = 1 - 0 = 1$$

$$A_{23} = (-1)^{2+3} M_{23} = (-1)(1) = -1$$

$$M_{31} = \begin{vmatrix} 0 & 4 \\ 5 & -1 \end{vmatrix}$$

$$A_{31} = (-1)^{3+1} M_{31} = -20$$

$$M_{32} = \begin{vmatrix} 1 & 4 \\ 3 & -1 \end{vmatrix} = -1 - 12 = -13$$

$$A_{32} = (-1)^{3+2} M_{32} = (-1)(-13) = 13$$

Adjoint of a Matrix

The adjoint of a Square Matrix $A=(a_{ij})$ $n \times n$ is defined as the transpose of the matrix (A_{ij}) $n \times n$. Above A_{ij} is the cofactor of element a_{ij} . Adjoint of the matrix. It is denoted by $\text{adj} A$.

$$\text{Let } A = \begin{bmatrix} a_{11} & a_{12} & a_{13} \\ a_{21} & a_{22} & a_{23} \\ a_{31} & a_{32} & a_{33} \end{bmatrix} \text{ then}$$

$$\text{adj } A = \text{transpose of } A = \begin{bmatrix} A_{11} & A_{12} & A_{13} \\ A_{21} & A_{22} & A_{23} \\ A_{31} & A_{32} & A_{33} \end{bmatrix}$$

$$\text{adj } A = \begin{bmatrix} A_{11} & A_{21} & A_{31} \\ A_{12} & A_{22} & A_{32} \\ A_{13} & A_{23} & A_{33} \end{bmatrix}$$

$$\text{Eg: Find adj } A \text{ for } A = \begin{bmatrix} 2 & 3 \\ 1 & 4 \end{bmatrix}$$

$$A_{11} = (-1)^{1+1} \cdot 4 = 4, \quad A_{12} = (-1)^{1+2} \cdot 1 = -1$$

$$A_{21} = (-1)^{2+1} \cdot 3 = -3, \quad A_{22} = (-1)^{2+2} \cdot 2 = 2$$

$$\text{Cofactor Matrix} = \begin{bmatrix} A_{11} & A_{12} \\ A_{21} & A_{22} \end{bmatrix} = \begin{bmatrix} 4 & -1 \\ -3 & 2 \end{bmatrix}$$

$$\text{adj } A = \begin{bmatrix} 4 & -3 \\ -1 & 2 \end{bmatrix}$$

Remark: For a square matrix of order 2, given by $A = \begin{bmatrix} a_{11} & a_{12} \\ a_{21} & a_{22} \end{bmatrix}$

The $\text{adj } A$ can also be obtained by interchanging a_{11} and a_{22} and by changing the signs of a_{12} and a_{21} .

$$\text{Adj } A = \begin{bmatrix} a_{22} & -a_{12} \\ -a_{21} & a_{11} \end{bmatrix}$$

$$\text{eg: If } A = \begin{bmatrix} 1 & -2 \\ 3 & -4 \end{bmatrix} \text{ then } \text{adj } A = \begin{bmatrix} -4 & 2 \\ -3 & 1 \end{bmatrix}$$

Theorem

If A is any square matrix of order n , then $A \cdot \text{adj } A = \text{adj } A \cdot A = |A| I$.

Above I is the square matrix.

Singular and Non Singular Matrix

A square matrix A is said to be singular if $|A| = 0$

eg:- $A = \begin{bmatrix} 2 & 3 \\ 4 & 6 \end{bmatrix}$ hence $|A| = 12 - 12 = 0$

\therefore A is non singular.

Non Singular

A square matrix A is said to be non singular if $|A| \neq 0$.

Eg:- $A = \begin{bmatrix} 1 & 2 \\ 3 & 4 \end{bmatrix}$ then $|A| = 4 - 6 = -2 \neq 0$

Hence A is non Singular.

Inverse of a Matrix

Let A be a square matrix of order m. If we can find a square matrix B of order m such that $AB = BA = I$ then B is called the inverse of A and it is denoted by A^{-1} . Inverse of matrix is unique.

Necessary and sufficient condition for Inverse

A square matrix has inverse iff it is non singular

ie, A^{-1} exists $\Leftrightarrow |A| \neq 0$

Let A is square matrix.

Then $A^{-1} = \frac{adjA}{|A|}$

Examples

1) Find A^{-1} , for $A = \begin{bmatrix} 1 & 2 \\ 3 & 4 \end{bmatrix}$

Solution

We have $|A| = \begin{vmatrix} 1 & 2 \\ 3 & 4 \end{vmatrix}$

$= 4 - 6$

$= -2$

$adj A = \begin{bmatrix} 4 & -2 \\ -3 & 1 \end{bmatrix}$

$\therefore A^{-1} = \frac{1}{|A|} . adjA$

$$= \frac{-1}{2} \times \begin{bmatrix} 4 & -2 \\ -3 & 1 \end{bmatrix} = \begin{bmatrix} \frac{-4}{2} & \frac{-2}{2} \\ -3 \times \frac{1}{2} & 1 \times \frac{1}{2} \end{bmatrix}$$

$$= \begin{bmatrix} -2 & 1 \\ \frac{3}{2} & \frac{-1}{2} \end{bmatrix}$$

2) If $A = \begin{bmatrix} 1 & 3 & 3 \\ 1 & 4 & 3 \\ 1 & 3 & 4 \end{bmatrix}$ then verify that $A \cdot \text{adj}A = |A| \cdot I$. Also find A^{-1} .

Solution

$$|A| = 1(16-9) - 3(4-3) + 3(3-4)$$

$$= 1 \neq 0$$

Now $A_{11}=7, A_{12}=-1, A_{13}=-1, A_{21}=-3,$
 $A_{22}=1, A_{23}=0, A_{31}=-3, A_{32}=0, A_{33}=1$

$$\therefore A = \begin{bmatrix} 7 & -3 & -3 \\ -1 & 1 & 0 \\ -1 & 0 & 1 \end{bmatrix}$$

$$A \cdot \text{adj}A = \begin{bmatrix} 1 & 3 & 3 \\ 1 & 4 & 3 \\ 1 & 3 & 4 \end{bmatrix} \begin{bmatrix} 7 & -3 & -3 \\ -1 & 1 & 0 \\ -1 & 0 & 1 \end{bmatrix}$$

$$= \begin{bmatrix} 7-3-3 & -3+3+0 & -3+0+3 \\ 7-4-3 & -3+4+0 & -3+0+3 \\ 7-3-4 & -3+3+0 & -3+0+4 \end{bmatrix}$$

$$= \begin{bmatrix} 1 & 0 & 0 \\ 0 & 1 & 0 \\ 0 & 0 & 1 \end{bmatrix} = 1 \begin{bmatrix} 1 & 0 & 0 \\ 0 & 1 & 0 \\ 0 & 0 & 1 \end{bmatrix}$$

$$A^{-1} = \frac{\text{adj}A}{|A|} = \frac{1}{1} \begin{bmatrix} 7 & -3 & -3 \\ -1 & 1 & 0 \\ -1 & 0 & 1 \end{bmatrix}$$

$$= \begin{bmatrix} 7 & -3 & -3 \\ -1 & 1 & 0 \\ -1 & 0 & 1 \end{bmatrix}$$

Application of Determinants and Matrices

Consistent Equation

A system of equations is said to be consistent if it has a solution.

Inconsistent System

A system of equations is said to be inconsistent if its solution does not exist.

Solution of system of Linear Equations

Consider the system of Equations

$$a_1x + b_1y + c_1z = d_1$$

$$a_2x + b_2y + c_2z = d_2$$

$$a_3x + b_3y + c_3z = d_3$$

The system of equations can be represented as $Ax=B$ where,

$$A = \begin{bmatrix} a_1 & b_1 & c_1 \\ a_2 & b_2 & c_2 \\ a_3 & b_3 & c_3 \end{bmatrix}, \quad X = \begin{bmatrix} x \\ y \\ z \end{bmatrix}, \quad B = \begin{bmatrix} d_1 \\ d_2 \\ d_3 \end{bmatrix}$$

If A is non singular then we have A^{-1} exists.

$$AX = B$$

Multiplying on both sides to the left.

$$A^{-1}(AX) = A^{-1}B$$

$$(A^{-1}A)X = A^{-1}B$$

$$IX = A^{-1}B$$

$$\boxed{X = A^{-1}B}$$

By using A^{-1} we can solve the system of equations. This method of finding solutions of system of equations is called matrix method.

Examples

Solve the system of Equations using matrix method

$$2x + 5y = 1$$

$$3x + 2y = 7$$

$$\text{then } A = \begin{bmatrix} 2 & 5 \\ 3 & 2 \end{bmatrix}, \quad X = \begin{bmatrix} x \\ y \end{bmatrix}, \quad B = \begin{bmatrix} 1 \\ 7 \end{bmatrix}$$

Then system can be represented as

$$AX = B$$

$$\text{Then } X = A^{-1}B$$

$$A^{-1} = \frac{\text{adj}A}{|A|}$$

$$|A| = \begin{vmatrix} 2 & 5 \\ 3 & 2 \end{vmatrix} = 4 - 15 = -11$$

$$\text{Adj}.A = \begin{vmatrix} 2 & -5 \\ -3 & 2 \end{vmatrix}$$

$$A^{-1} = \frac{-1}{11} \begin{bmatrix} 2 & -5 \\ -3 & 2 \end{bmatrix}$$

$$X = A^{-1}B$$

$$= \frac{-1}{11} \begin{bmatrix} 2 & -5 \\ -3 & 2 \end{bmatrix} \begin{bmatrix} 1 \\ 7 \end{bmatrix}$$

$$= \frac{-1}{11} \begin{bmatrix} 2 + (-35) \\ -3 + 14 \end{bmatrix}$$

$$= \frac{-1}{11} \begin{bmatrix} -33 \\ 11 \end{bmatrix}$$

$$\text{ie, } \begin{bmatrix} x \\ y \end{bmatrix} = \begin{bmatrix} -33 \times \frac{-1}{11} \\ 11 \times \frac{-1}{11} \end{bmatrix} = \begin{bmatrix} +3 \\ -1 \end{bmatrix}$$

$$\therefore x = 3, y = -1$$

Example

Solve the system of Equations

$$\frac{2}{x} + \frac{3}{y} + \frac{10}{z} = 4$$

$$\frac{4}{x} + \frac{6}{y} + \frac{5}{z} = 1$$

$$\frac{6}{x} + \frac{9}{y} - \frac{20}{z} = 2$$

The system of equations can be represented as $AX=B$

$$A = \begin{bmatrix} 2 & 3 & 10 \\ 4 & -6 & 5 \\ 6 & 9 & -20 \end{bmatrix} \quad X = \begin{bmatrix} 1 \\ x \\ 1 \\ y \\ 1 \\ z \end{bmatrix} \quad B = \begin{bmatrix} 4 \\ 1 \\ 2 \end{bmatrix}$$

$$X = A^{-1}B$$

$$\begin{array}{lll} A_{11} = 75 & A_{12} = 110 & A_{13} = 72 \\ A_{21} = 150 & A_{22} = -100 & A_{23} = 0 \\ A_{31} = -45 & A_{32} = 50 & A_{33} = -24 \end{array}$$

$$adj.A = \begin{bmatrix} 75 & 150 & -45 \\ 110 & -100 & 50 \\ 72 & 0 & -24 \end{bmatrix}$$

$$A^{-1} = \frac{adj.A}{|A|}$$

$$\begin{aligned} |A| &= 2(120 - 45) - 3(-80 - 30) + 10(36 + 36) \\ &= 2 \times 75 - 3 \times -110 + 72 \times 10 \\ &= 540 \end{aligned}$$

$$= A^{-1} = \frac{1}{540} \begin{bmatrix} 75 & 150 & -45 \\ 110 & -100 & 50 \\ 72 & 0 & -24 \end{bmatrix}$$

$$X = A^{-1}B$$

$$= \frac{1}{540} \begin{bmatrix} 75 & 150 & -45 \\ 110 & -100 & 50 \\ 72 & 0 & -24 \end{bmatrix} \begin{bmatrix} 4 \\ 1 \\ 2 \end{bmatrix}$$

$$= \begin{bmatrix} 2 \\ 3 \\ 5 \end{bmatrix}$$

$$x = 2, \quad y = 3, \quad z = 5$$

UNIT TEST

Time : 40 mts

Max.Marks : 20

1) If the matrix $\begin{bmatrix} 1 & 7 & 5 \\ 0 & 2 & 3 \\ 0 & 4 & x \end{bmatrix}$ is not invertible then $x = \dots\dots\dots$

2) Let A be a 3×3 matrix with $|A| = 3$ then $|2A| = \dots\dots\dots$

3) If $\begin{vmatrix} x & 3 \\ 5 & 2 \end{vmatrix} = 5$ then $x = \dots\dots\dots$

4) Let A be a Non Singular Matrix of order 3×3 . Then $|\text{adj } A|$ is equal to $\dots\dots\dots$
(a. $|A|$ b. $|A|^2$ c. $|A|^3$ d. $3|A|$)

5) $\begin{vmatrix} 2 & 7 & 5 \\ 6 & 21 & 15 \\ 5 & 9 & 86 \end{vmatrix} = \dots\dots\dots$ (one each)

6) Let $A = \begin{bmatrix} 2 & 5 \\ 3 & 2 \end{bmatrix}$

- a) Find $|A|$ (1)
- b) Find $\text{adj } A$ (1)
- c) Find A^{-1} (1)
- d) Using A^{-1} solve the system equations (2)

$2x + 5y = 1$

$3x + 2y = 7$

7) Using properties of determinant

a) Show that $\begin{vmatrix} -a^2 & ab & ac \\ ba & -b^2 & bc \\ ca & cb & -c^2 \end{vmatrix} = 4a^2b^2c^2$ (2)

b) Using determinant, Find the equation of line joining (1,2) and (3,6) (2)

8) Let $A = \begin{bmatrix} 2 & -3 & 5 \\ 3 & 2 & -4 \\ 1 & 1 & -2 \end{bmatrix}$

- a) Find $|A|$ (1)

- b) Find $\text{adj } A$. (2)
c) Find A^{-1} (1)
d) Solve the system of Equations

$$2x - 3y + 5z = 11$$

$$3x + 2y - 4z = -5$$

$$x + y - 2z = -3$$

(2)

5. FUNCTIONS LIMITS & CONTINUITY

Domain and Range

Consider the function $y=f(x)$, the set of all possible x -values is called the domain of f and set of y -values that results when x -values over the domain is called range of f .

Eg:- Find the domain of (i) $f(x) = x^2$, (ii) $f(x) = \frac{1}{(x-1)(x-2)}$

Ans: i) The function f is a polynomial. Hence the domain is the interval $(-\infty, +\infty)$ or \mathbb{R} set of reals.

ii) The domain = $\mathbb{R} - \{x: (x-1)(x-2) = 0\} = \mathbb{R} - \{1, 2\}$

Limits : If the values of $f(x)$ can be made as close to L , by taking the values of ' x ' sufficiently close to ' a '

(but $\neq a$) then we write $\lim_{x \rightarrow a} f(x)$

Eg:- i) $\lim_{x \rightarrow 2} x^2 = 2^2 = 4$ (ie, when $x \rightarrow 2$, $x^2 \rightarrow 4$)

ii) $\lim_{x \rightarrow 3} (x^2 - 2x + 5) = 3^2 - 2 \cdot 3 + 5 = 9 - 6 + 5 = 8$ (ie, when $x \rightarrow 3$, $x^2 - 2x + 5 \rightarrow 8$)

Right and left hand limits

If the values of $f(x)$ can be made as close to R , by taking values of x sufficiently close ' a ' (but greater than a), then we write $\lim_{x \rightarrow a^+} f(x) = R$ called the right hand limit.

If the values of $f(x)$ can be made as close to L by taking values of x sufficiently close to a (but less than a) then $\lim_{x \rightarrow a^-} f(x) = L$ called the left hand limit.

Eg: $f(x) = \begin{cases} \frac{|x|}{x}, & x \neq 0 \\ 0, & x = 0 \end{cases}$ then $\frac{|x|}{x} \rightarrow 1$, when $x \rightarrow 0^+$ and $\frac{|x|}{x} \rightarrow -1$, when $x \rightarrow 0^-$

* Limit exist only when the right hand limit and left hand limit are coincide.

ie, $\lim_{x \rightarrow a^+} f(x) = \lim_{x \rightarrow a^-} f(x)$

Results

$\lim_{x \rightarrow a} k = k$ (where k is constant)

* $\lim_{x \rightarrow a} [f(x) + g(x)] = \lim_{x \rightarrow a} f(x) + \lim_{x \rightarrow a} g(x)$

Eg:- $\lim_{x \rightarrow \pi/2} [\sin x + \cos x] = \lim_{x \rightarrow \pi/2} \sin x + \lim_{x \rightarrow \pi/2} \cos x = 1 + 0 = 1$

* $\lim_{x \rightarrow a} [f(x) - g(x)] = \lim_{x \rightarrow a} f(x) - \lim_{x \rightarrow a} g(x)$

Eg:- $\lim_{x \rightarrow \pi/4} [\sin x - \tan x] = \lim_{x \rightarrow \pi/4} \sin x - \lim_{x \rightarrow \pi/4} \tan x = \frac{1}{\sqrt{2}} - 1 = \frac{1 - \sqrt{2}}{\sqrt{2}}$

* $\lim_{x \rightarrow a} [f(x) \cdot g(x)] = \lim_{x \rightarrow a} f(x) \cdot \lim_{x \rightarrow a} g(x)$

Eg:- $\lim_{x \rightarrow 3} [(x+3)(x-5)] = \lim_{x \rightarrow 3} (x+3) \lim_{x \rightarrow 3} (x-5) = (3+3)(3-5) = 6 \cdot (-2) = -12$

* $\lim_{x \rightarrow a} \left[\frac{f(x)}{g(x)} = \frac{\lim_{x \rightarrow a} f(x)}{\lim_{x \rightarrow a} g(x)} \right]$

Eg:- $\lim_{x \rightarrow 4} \left(\frac{x+1}{x+5} \right) = \frac{\lim_{x \rightarrow 4} (x+1)}{\lim_{x \rightarrow 4} (x+5)} = \frac{4+1}{4+5} = \frac{5}{9}$

* $\lim_{x \rightarrow a} [k \cdot f(x)] = k \cdot \lim_{x \rightarrow a} f(x); k \text{ is constant}$

Eg:- $\lim_{x \rightarrow \pi/2} [3 \sin x] = 3 \cdot \lim_{x \rightarrow \pi/2} [\sin x] = 3 \cdot \sin \frac{\pi}{2} = 3 \cdot 1 = 3$ ($\because \sin \frac{\pi}{2} = 1$)

Computing limit for the rational function $\frac{p(x)}{q(x)}$

a. $\lim_{x \rightarrow 1} \frac{x-1}{x+2} = \frac{1-1}{1+2} = 0$

b. $\lim_{x \rightarrow 3} \frac{x-3}{x^2-9} = \frac{1-1}{1+2} = 0/0$

Hence it is evaluated as follows.

$\lim_{x \rightarrow 3} \frac{(x-3)}{(x-3)(x+3)}$ (factorising the denominator)

$$= \lim_{x \rightarrow 3} \frac{1}{x+3} = \frac{1}{3+3} = \frac{1}{6}$$

c. $\lim_{x \rightarrow 2} \frac{x^2 - 4}{x^2 - 5x + 6} = \frac{2^2 - 4}{2^2 - 5 \cdot 2 + 6} = \frac{4 - 4}{4 - 10 + 6} = \frac{0}{0}$ form. Hence it is evaluated as follows.

$$\lim_{x \rightarrow 2} \frac{(x-2)(x+2)}{(x-2)(x+3)} \quad (\text{factorising both numerator and denominator})$$

$$\lim_{x \rightarrow 2} \left(\frac{x+2}{x+3} \right) = \frac{2+2}{2+3} = \frac{4}{5}$$

Special Limits

a) i) $\lim_{x \rightarrow a} \frac{x^n - a^n}{x - a} = na^{n-1}$

Eg:- $\lim_{x \rightarrow 2} \frac{x^3 - 2^3}{x - 2} = 3(2)^{3-1} = 3 \cdot 2^2 = 12$

ii) $\lim_{x \rightarrow -1} \frac{x^2 + 1}{x + 1} = \lim_{x \rightarrow -1} \frac{x^5 - (-1)^5}{x - (-1)} = 5(-1)^{5-1} = 5(-1)^4 = 5$

iii) $\lim_{x \rightarrow 3} \frac{x^3 - 27}{x - 3} = \lim_{x \rightarrow 3} \frac{x^3 - 3^3}{x - 3} = 3(3)^{3-1} = 3 \cdot 9 = 27$

b) $\lim_{x \rightarrow 0} \frac{e^x - 1}{x} = 1$

c) $\lim_{\theta \rightarrow 0} \frac{\sin \theta}{\theta} = 1, \quad \lim_{x \rightarrow 0} \frac{\sin ax}{x} = \lim_{x \rightarrow 0} \frac{\sin ax}{ax} \cdot a = a \cdot \lim_{ax \rightarrow 0} \left(\frac{\sin ax}{ax} \right)$

$$= a \cdot \lim_{ax \rightarrow 0} \left(\frac{\sin ax}{ax} \right)$$

$$= a \cdot 1$$

$$= a$$

d) $\lim_{x \rightarrow 0} \frac{\log(1+x)}{x} = 1$

Continuity

The continuity of a function $y=f(x)$ is easily calculated by drawing its graph. If the graph has no break or jump, the function is continuous on the given interval.

Eg:- a) $f(x) = |x|$, absolute value function,
graph, $|x|$ is continuous.

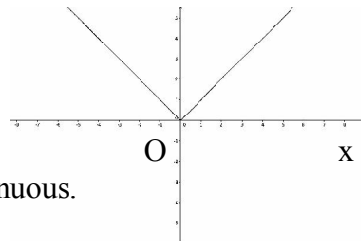

from the

b) $f(x) = \sin x, x \in (0, 2\pi)$

The graph has no jump or break, it is continuous.

(\because the graph has no jump or break)

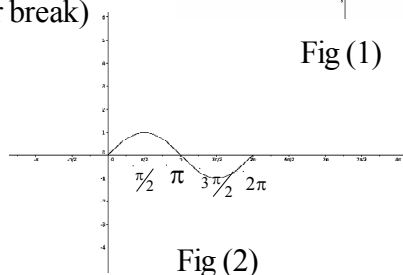

Fig (1)

Fig (2)

Definition: A function $f(x)$ is continuous at the point $x = a$ if

$$\lim_{x \rightarrow a} f(x) = f(a) \quad \text{or} \quad \lim_{x \rightarrow a^+} f(x) = \lim_{x \rightarrow a^-} f(x) = f(a)$$

Problem

Examine the continuity of the function $f(x) = \begin{cases} 1 + 2x, & 0 \leq x < 2 \\ x^2 + 1, & 2 \leq x < 4 \end{cases}$ at $x=2$

Ans: $f(2^+) = \lim_{x \rightarrow 2^+} f(x) = \lim_{x \rightarrow 2^+} (x^2 + 1) = 2^2 + 1 = 5$

$f(2^-) = \lim_{x \rightarrow 2^-} f(x) = \lim_{x \rightarrow 2^-} (1 + 2x) = 1 + 2 \times 2 = 5$

$f(2) = 2^2 + 1 = 5$, Hence $f(2^+) = f(2^-) = f(2) \Rightarrow f$ is continuous at $x=2$

Problem

Find the value of k if $f(x) = \begin{cases} kx^2, & x \leq 2 \\ 2x + k, & x > 2 \end{cases}$ is continuous

$\lim_{x \rightarrow 2^+} f(x) = \lim_{x \rightarrow 2^+} (2x + k) = 4 + k$

$\lim_{x \rightarrow 2^-} f(x) = \lim_{x \rightarrow 2^-} (kx^2) = k \times 2^2 = 4k$

Since $f(x)$ is continuous at $x=2$, we have $\lim_{x \rightarrow 2^+} f(x) = \lim_{x \rightarrow 2^-} f(x) \Rightarrow 4+k=4k \Rightarrow 4=3k \Rightarrow k = \frac{4}{3}$

Problem

Find the value of a and b if $f(x) = \begin{cases} 1; x \leq 3 \\ ax + b; 3 < x < 5 \\ 3; x \geq 5 \end{cases}$ is continuous at $x=3$ and $x=5$.

$$\lim_{x \rightarrow 3^+} f(x) = \lim_{x \rightarrow 3^+} (ax + b) = 3a + b$$

$$\lim_{x \rightarrow 3^-} f(x) = \lim_{x \rightarrow 3^-} (1) = 1 \text{ since } f(x) \text{ is continuous at } x=3, \text{ to get,}$$

$$f(3^+) = f(3^-) \Rightarrow 3a + b = 1 \dots\dots\dots(1)$$

$$\text{again } = \lim_{x \rightarrow 5^+} f(x) = \lim_{x \rightarrow 5^+} (3) = 3,$$

$$= \lim_{x \rightarrow 5^-} f(x) = \lim_{x \rightarrow 5^-} (ax + b) = 5a + b$$

$$\text{Since } f \text{ is continuous at } x=5, \text{ to get } \lim_{x \rightarrow 5^-} f(x) = \lim_{x \rightarrow 5^+} f(x) \Rightarrow 5a + b = 3 \dots\dots\dots(2)$$

Solving (1) & (2)

$$\begin{array}{rcl} 3a + b = 1 & \dots\dots\dots(1) \\ 5a + b = 3 & \dots\dots\dots(2) \\ (2) - (1) \rightarrow 2a = 2 & \Rightarrow a = 1 \end{array}$$

Put $a=1$, in (1) to get $3 \times 1 + b = 1 \Rightarrow 3 + b = 1 \Rightarrow b = -2$

$a = 1$ & $b = -2$

Hence the result.

Functions limits and continuity

ആദ്യമായി $y=f(x)$ എന്ന ഏകദം (ഫങ്ഷൻ) പരിഗണിക്കുക.

- x സ്വീകരിക്കുന്ന വിലകളുടെ ഗണത്തിനെ ഏകദത്തിന്റെ ഡൊമൈൻ എന്ന് വിളിക്കുന്നു. x വ്യത്യസ്ത വിലകൾ സ്വീകരിക്കുമ്പോൾ y യ്ക്ക് ലഭിക്കുന്ന വിലകളുടെ ഗണം പ്രസ്തുത ഏകദത്തിന്റെ റേഞ്ച് എന്നറിയപ്പെടുന്നു.
- ഒരു ഫങ്ഷന്റെ ലിമിറ്റ് എക്സിസ്റ്റ് ചെയ്യണമെങ്കിൽ അതിന്റെ റൈറ്റ് സൈഡ് ലിമിറ്റും ലെഫ്റ്റ് സൈഡ് ലിമിറ്റും തുല്യമായിരിക്കണം.

Transformation of functions

- 1) $f(x)$ transforms to $f(x)+a$
If $a>0$ then $f(x)+a$ shift the graph of $f(x)$ 'a' unit upwards.
- 2) $f(x)$ transforms to $f(x) - a$
If $a>0$ then $f(x)-a$ shift the graph of $f(x)$ 'a' unit downward.
- 3) $f(x)$ transforms to $f(x+a)$
If $a>0$ then $f(x+a)$ shift the graph 'a' unit towards left.
- 4) $f(x)$ transforms to $f(x-a)$
If $a>0$ then $f(x-a)$ shift the graph 'a' unit towards right.

Illustration

Consider the function $f(x) = x^2$

Then the graph of the function $g(x) = f(x)+2 = x^2+2$. It is obtained by shifting the graph of $f(x)=x^2$ 2 unit upward as shown below

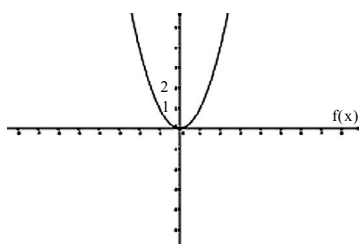

fig.1

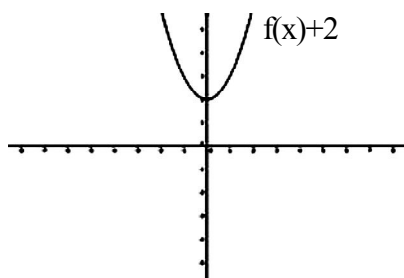

fig.2

$f(x) \rightarrow f(x)-1$ is obtained as shown below

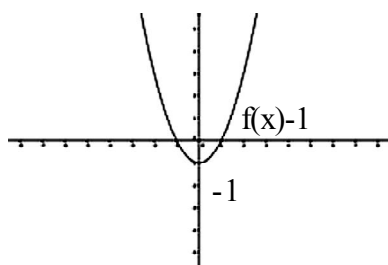

fig.3

$p(x) = f(x+2) = (x+2)^2$ is obtained as shown below.

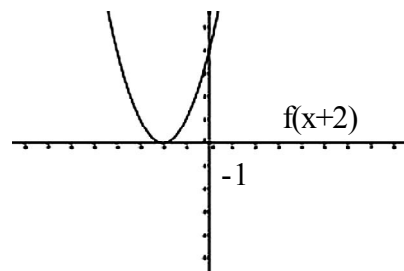

fig.4

$q(x) = f(x-2) = (x-2)^2$ is obtained as shown below

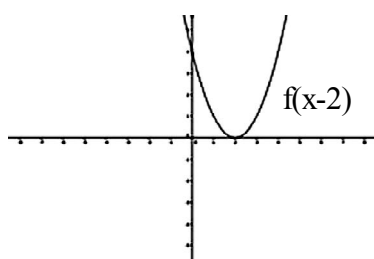

fig.5

5) $f(x)$ transforms to a $f(x)$; $a > 1$

If we multiply $f(x)$ by $a > 1$, the graph of $f(x)$ is stretched 'a' times vertically

Illustration

Consider $f(x) = \sin x$

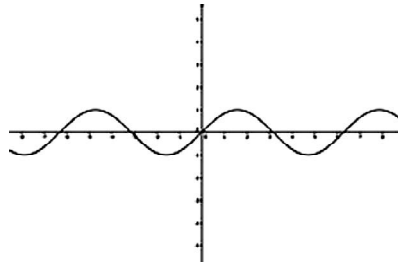

fig.6

$g(x) = 2f(x) = 2\sin x$ Stretch the graph twice vertically

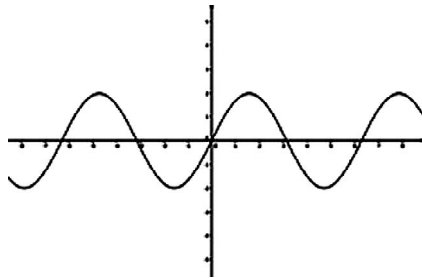

fig.7

6) $f(x)$ transforms to $f(ax)$

If $a > 1$ $f(ax)$ shrink the graph of $f(x)$ a lines horizontally.

Illustration

Consider $f(x) = \sin x$

$h(x) = f(2x) = \sin 2x$ shrink the graph of $f(x)$ 'a' times unit horizontally.

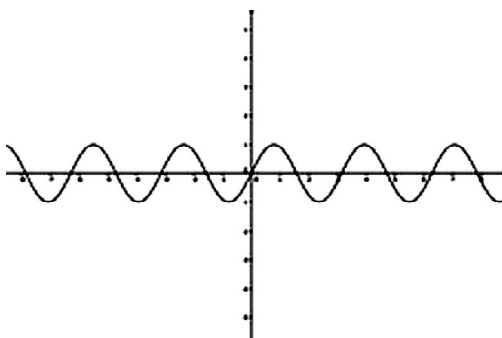

fig.8

Alternate method to find left hand and right hand limit

$$\lim_{x \rightarrow a^-} f(x) = \lim_{h \rightarrow 0} f(a-h) \quad \text{where } h > 0$$

$$\lim_{x \rightarrow a^+} f(x) = \lim_{h \rightarrow 0} f(a+h) \quad \text{where } h > 0$$

Eg:- Consider $f(x) = \begin{cases} x & \text{if } x < 1 \\ x+2 & \text{if } x \geq 1 \end{cases}$

$$\lim_{x \rightarrow 1^-} f(x) = \lim_{h \rightarrow 0} f(1-h)$$

$$= \lim_{h \rightarrow 0} (1-h)$$

$$= 1 - 0 = 1$$

$$\lim_{x \rightarrow 1^+} f(x) = \lim_{h \rightarrow 0} f(1+h) = \lim_{h \rightarrow 0} (1+h+2), \text{ as } 1+h > 1$$

$$= 1+0+2 = 3$$

Continuity

How to check whether a function $f(x)$ is continuous at $x=a$

Step 1 - Find $\lim_{x \rightarrow a^-} f(x)$

Step 2 - Find $\lim_{x \rightarrow a^+} f(x)$

Step 3 - Find $f(a)$

If $\lim_{x \rightarrow a^-} f(x) = \lim_{x \rightarrow a^+} f(x) = f(a)$ then the function is continuous at $x=a$

Otherwise f is discontinuous at $x=a$

A function fails to be continuous at $x=a$ due to the following reasons.

1) $\lim_{x \rightarrow a^-} f(x)$ does not exist

2) $\lim_{x \rightarrow a^+} f(x)$ does not exist

3) $\lim_{x \rightarrow a^-} f(x) \neq \lim_{x \rightarrow a^+} f(x)$

4) $\lim_{x \rightarrow a} f(x) \neq f(a)$

UNIT TEST

Score 20

Time : 40 minutes

I. Choose the correct answer from the given alternatives. (Score 1 each)

1. $\lim_{x \rightarrow 0} \frac{\log(1+x)}{\sin x}$ is equal to
a) 2 b) 1 c) e d) none of these
- 2) Let $f(x) = \begin{cases} x+a & x < 1 \\ ax^2 + 1 & x \geq 1 \end{cases}$
then f(x) is continuous at x=1 for
a) a=0 b) a=1 c) for all $a \in \mathbb{R}$ d) none of these
- 3) If $f(x) = |x|$ then f'(0) is
a) 0 b) 1 c) -1 d) none of these
- 4) If $x^p y^q = (x+y)^{p+q}$ then $\frac{dy}{dx} =$
a) $\frac{x}{y}$ b) $\frac{y}{x}$ c) $\frac{x}{x+y}$ d) $\frac{y}{y+x}$
- 5) If $y = a e^{mx} + b e^{-mx}$ then $\frac{d^2 y}{dx^2} =$
a) $m^2 y$ b) $-m^2 y$ c) my d) -my

II Answer the following

6) Discuss the continuity of f(x) at x=0

$$\text{If } f(x) = \begin{cases} 2x-1 & \text{if } x < 0 \\ 2x+1 & \text{if } x \geq 0 \end{cases} \quad (\text{Score 3})$$

7) Differentiate $\log(\sin x \sqrt{x^2+1})$ w.r. to x (Score 2)

8) Differentiate $e^{\sin x} + (\tan x)^x$ w.r.t x (Score 3)

9) If $x = a(\theta - \sin \theta)$
 $y = a(1 - \cos \theta)$

$$\text{Find } \frac{dy}{dx} \text{ at } \theta = \frac{\pi}{2} \quad (\text{Score 2})$$

10) Verify Lagrange's Mean Value theorem for the function $f(x) = \sqrt{x^2 - 4}$ in the interval (2,4)

11) Differentiate the function w.r.to $x \sin^{-1}\left(\frac{2x}{1+x^2}\right)$ (Score 2)

Answer and hints

1. b)
$$\frac{\log(1+x)}{\sin x} = \frac{\frac{\log(1+x)}{x}}{\frac{\sin x}{x}}$$

2. c) $\lim_{x \rightarrow 1^-} f(x) = 1 + a$ and

$$\lim_{x \rightarrow 1^+} f(x) = a + b \quad f(1) = a + 1$$

$$\lim_{x \rightarrow 1^-} f(x) = \lim_{x \rightarrow 1^+} f(x) = f(1) \text{ for any } a \in \mathbb{R}$$

3. d) $f(x) = |x|$ is not differentiable at $x = 0$

4. b) Take log on both sides and differentiate

5. (a)

6. $\lim_{x \rightarrow 0^-} f(x) = -1$ and $\lim_{x \rightarrow 0^+} f(x) = 1$

$\therefore f$ is not differentiable at $x=0$

7. Let $y = \log\left(\sin\sqrt{x^2 + 1}\right)$

$$\frac{dy}{dx} = \frac{1}{\sin\sqrt{x^2 + 1}} \cdot \frac{1 \times (2x)}{2\sqrt{x^2 + 1}} = \frac{x}{\sqrt{x^2 + 1} \sin\sqrt{x^2 + 1}}$$

8. Let $y = e^{\sin x} + (\tan x)^x$

Let $u = e^{\sin x}$ and $v = (\tan x)^x$

$$\frac{dy}{dx} = \frac{du}{dx} + \frac{dv}{dx}$$

By logarithmic differentiation find $\frac{du}{dx}$ and $\frac{dv}{dx}$

9. $\frac{dx}{d\theta} = a(1 - \cos\theta)$

$$\frac{dy}{dx} = a(\sin\theta)$$

$$\frac{dy}{dx} = \frac{dy}{d\theta} \bigg/ \frac{dx}{d\theta} = \frac{a \sin\theta}{a(1-\cos\theta)}$$

$$= \frac{\sin\theta}{1-\cos\theta}$$

$$\text{at } \theta = \frac{\pi}{2}, \frac{dy}{dx} = \frac{\sin \frac{\pi}{2}}{1-\cos \frac{\pi}{2}} = \frac{1}{1-0} = 1$$

10. Given $f(x) = \sqrt{x^2 - 4}$

f is continuous on $[2, 4]$ and differentiable on $(2, 4)$

\therefore By Lagrange's mean value theorem, there exist $c \in (2, 4)$ such that $f'(c) = \frac{f(4) - f(2)}{4 - 2}$

$$f(x) = \sqrt{x^2 - 4} \quad \therefore f(4) = \sqrt{4^2 - 4} = \sqrt{12} = 2\sqrt{3}$$

$$f(2) = \sqrt{2^2 - 4} = 0$$

$$\therefore \frac{f(4) - f(2)}{4 - 2} = \frac{2\sqrt{3}}{2} = \sqrt{3}$$

$$= f'(x) = \frac{1}{2\sqrt{x^2 - 4}} \cdot 2x$$

$$= \frac{x}{\sqrt{x^2 - 4}}$$

$$f'(c) = \frac{c}{\sqrt{c^2 - 4}}$$

$$f'(c) = \frac{f(4) - f(2)}{4 - 2} \Rightarrow \frac{c}{\sqrt{c^2 - 4}} = \sqrt{3}$$

$$\therefore \frac{c^2}{c^2 - 4} = 3$$

$$c^2 = 3(c^2 - 4)$$

$$\therefore 2c^2 = 12 \quad c^2 = 6 \quad c = \sqrt{6} \in (2, 4)$$

Hence Lagrange's mean value theorem is verified.

11. Let $y = \text{Sin}^{-1}\left(\frac{2x}{1+x^2}\right)$ Put $x = \tan \theta$

$$\text{Then } y = \text{Sin}^{-1}\left(\frac{2x}{1+x^2}\right) = \text{Sin}^{-1}\left(\frac{2 \tan \theta}{1 + \tan^2 \theta}\right)$$

$$= \text{Sin}^{-1}(\text{Sin}2\theta)$$

$$= 2\theta$$

$$= 2 \tan^{-1}(x)$$

$$\therefore = 2 \cdot \frac{1}{1+x^2} = \frac{2}{1+x^2}$$

6. DIFFERENTIATION

The derivative is a mathematical tool, which is used to study the rate at which the quantities change.

- Rate of change of quantities നെക്കുറിച്ച് പഠിക്കുവാൻ സഹായിക്കുന്ന ഗണിതശാസ്ത്രസംജ്ഞയാണ് differentiation.

Definition

The derivative of $f(x)$ at $x=a$ is denoted as $f'(a)$ and is defined as $f'(a) = \lim_{x \rightarrow a} \left[\frac{f(x) - f(a)}{x - a} \right]$

- $f(x)$ derivative $x=a$ എന്ന പോയിന്റിൽ $f'(a)$ എന്ന് സൂചിപ്പിക്കപ്പെടുന്നു. താഴെ പറയും പ്രകാരം അതിനെ നിർവ്വചിക്കാം.

$$f'(a) = \lim_{x \rightarrow a} \left(\frac{f(x) - f(a)}{x - a} \right)$$

Remarks

Geometrical meaning of the derivative is slope of tangent. The right hand derivative of $f(a)$ is

$$\lim_{h \rightarrow 0} \text{it} \frac{f(a + h) - f(a)}{h}$$

The left hand derivative of $f(a)$ is $\lim_{h \rightarrow 0} \frac{f(a) - f(a - h)}{h}$

Problem

Find the right hand and left hand derivative of $f(x) = |x|$ at $x=0$

Right hand derivative at $x=0$ is $\lim_{h \rightarrow 0} \text{it} \frac{f(0+h) - f(0)}{h} = \lim_{h \rightarrow 0} \text{it} \frac{f(h) - f(0)}{h} = \frac{|h|}{h} = 1$

Left hand derivative at $x=0$ is $\lim_{h \rightarrow 0} \text{it} \frac{f(0) - f(0-h)}{h} = \lim_{h \rightarrow 0} \text{it} \frac{|-h|}{h} = -1$

Note: Every differentiable function is continuous.

Some Standard results

* $\frac{d}{dx}(x^n) = nx^{n-1}$	* $\frac{d}{dx}(x) = 1$	* $\frac{d}{dx}\left(\frac{1}{x}\right) = \frac{-1}{x^2}$
* $\frac{d}{dx}(\log x) = \frac{1}{x}$	* $\frac{d}{dx}(e^x) = e^x$	* $\frac{d}{dx}(\sqrt{x}) = \frac{1}{2\sqrt{x}}$

$$\begin{aligned}
& * \frac{d}{dx}(a^x) = a^x \log a \quad * \frac{d}{dx}(\sin x) = \cos x \quad * \frac{d}{dx}(\cos x) = -\sin x \\
& * \frac{d}{dx}(\tan x) = \sec^2 x \quad * \frac{d}{dx}(\cot x) = -\operatorname{cosec}^2 x \quad * \frac{d}{dx}(\sec x) = \sec x \tan x \\
& * \frac{d}{dx}(\operatorname{cosec} x) = -\operatorname{cosec} x \cot x \quad * \frac{d}{dx}(\sin^{-1} x) = \frac{1}{\sqrt{1-x^2}} \quad * \frac{d}{dx}(\cos^{-1} x) = \frac{-1}{\sqrt{1-x^2}} \\
& * \frac{d}{dx}(\tan^{-1} x) = \frac{1}{1+x^2} \quad * \frac{d}{dx}(\cot^{-1} x) = \frac{-1}{1+x^2} \quad * \frac{d}{dx}(\sec^{-1} x) = \frac{1}{\sqrt{x^2-1}} \\
& * \frac{d}{dx}(\operatorname{cosec}^{-1} x) = \frac{-1}{x\sqrt{x^2-1}} \quad * \frac{d}{dx}(x^x) = x^x(1+\log x) \\
& * \frac{d}{dx}(k) = 0, \text{ k-constant} \quad * \frac{d}{dx}(k \cdot f(x)) = k \cdot \frac{d}{dx}f(x), \text{ k constant}
\end{aligned}$$

$$* \text{ Sum rule: } \frac{d}{dx}(f(x) + g(x)) = \frac{d}{dx}f(x) + \frac{d}{dx}g(x)$$

- Sum rule രണ്ട് ഫങ്ഷനുകളുടെ തുകയുടെ ഡെറിവേറ്റീവ് ഒരു ഫങ്ഷന്റെയും ഡെറിവേറ്റീവിന്റെയും തുകയ്ക്ക് തുല്യമായിരിക്കും.

$$\text{ie, } \frac{d}{dx}(f(x) + g(x)) = \frac{d}{dx}f(x) + \frac{d}{dx}g(x)$$

Eg:-1 Find The Derivative of $(\sin x + \cos x)$

Solution:

$$\begin{aligned}
\frac{d}{dx}[\sin x + \cos x] &= \frac{d}{dx}(\sin x) + \frac{d}{dx}(\cos x) \\
&= \cos x - \sin x
\end{aligned}$$

Eg:-2 Find the derivative of $\sin^{-1}(\sqrt{x}) + \cos^{-1}(\sqrt{x})$ with respect of x

$$\text{Solution: } \frac{d}{dx}(\sin^{-1} \sqrt{x} + \cos^{-1} \sqrt{x}) = \frac{d}{dx}(\sin^{-1} \sqrt{x}) + \frac{d}{dx}(\cos^{-1} \sqrt{x})$$

$$= \frac{1}{\sqrt{1-(\sqrt{x})^2}} \cdot \frac{1}{2\sqrt{x}} + \frac{-1}{\sqrt{1-(\sqrt{x})^2}} \cdot \frac{1}{2\sqrt{x}}$$

$$= \frac{1}{2\sqrt{x}} \left[\frac{1}{\sqrt{1-x}} - \frac{1}{\sqrt{1-x}} \right] = 0$$

Product Rule

$$\frac{d}{dx} \{f(x).g(x)\} = f(x). \frac{d}{dx} (g(x)) + g(x) \frac{d}{dx} f(x)$$

(Derivative product of two functions = Ist function x derivative of second function + second function x derivative of Ist function)

- Product rule : രണ്ട് ഫങ്ഷനുകളുടെ ഗുണനത്തിന്റെ ഡെറിവേറ്റീവ് = ഒന്നാം ഫങ്ഷൻ x (derivative of രണ്ടാം ഫങ്ഷൻ) + (രണ്ടാം ഫങ്ഷൻ) x (derivative of ഒന്നാം ഫങ്ഷൻ)

Eg:-(i) Find the derivative of $x.e^x$ with respect of x

$$\begin{aligned} \frac{d}{dx} (x.e^x) &= x. \frac{d}{dx} (e^x) + e^x \frac{d}{dx} (x) = x.e^x + e^x.1 \\ &= e^x(x+1) \end{aligned}$$

Eg:(ii) Find the derivative of $\text{Sin}x.\text{Cos}x$ with respect of x .

$$\begin{aligned} \frac{d}{dx} (\text{Sin}x.\text{Cos}x) &= \text{Sin}x \frac{d}{dx} (\text{Cos}x) + \text{Cos}x \frac{d}{dx} (\text{Sin}x) \\ &= \text{Sin}x. -\text{Sin}x + \text{Cos}x.\text{Sin}x \\ &= -\text{Sin}^2x + \text{Cos}^2x = \text{Cos}^2x - \text{Sin}^2x \end{aligned}$$

Eg:- (iii) Find the derivative of $e^x.\log x$ with respect of x .

$$\begin{aligned} \frac{d}{dx} (e^x.\log x) &= e^x \frac{d}{dx} (\log x) + \log x. \frac{d}{dx} (e^x) \\ e^x. \frac{1}{x} + \log x e^x &= e^x \left(\frac{1}{x} + \log x \right) \end{aligned}$$

Rational function

A function is of the form $\frac{p(x)}{q(x)}$, $q(x) \neq 0$ is known as rational function.

- രേഷണൽ (ഒരു ഫങ്ഷൻ $\frac{p(x)}{q(x)}$ എന്ന ഫോമിലാണെങ്കിൽ ആ ഫങ്ഷനെ രേഷണൽ ഫങ്ഷൻ എന്ന് വിളിക്കുന്നു) $q(x) \neq 0$

Quotient rule

$$\frac{d}{dx} \left(\frac{f(x)}{g(x)} \right) = \frac{g(x) \frac{d}{dx} f(x) - f(x) \frac{d}{dx} g(x)}{(g(x))^2}$$

$$\begin{aligned} \text{Eg:-(i)} \quad \frac{d}{dx} \left(\frac{x}{e^x} \right) &= \frac{e^x \cdot \frac{d}{dx} x - x \cdot \frac{d}{dx} (e^x)}{(e^x)^2} = \frac{e^x \cdot 1 - x \cdot e^x}{(e^x)^2} = \frac{e^x (1-x)}{(e^x)^2} \\ &= \frac{1-x}{e^x} \end{aligned}$$

Remarks

$$* \quad \frac{d}{dx} (f(x))^n = n \cdot (f(x))^{n-1} \cdot \frac{d}{dx} (f(x))$$

$$\text{Eg:-} \quad \frac{d}{dx} (x+5)^{10} = 10(x+5)^{10-1} \cdot \frac{d}{dx} (x+5) = 10(x+5)^9 \cdot 1 = 10(x+5)^9$$

$$* \quad \frac{d}{dx} (\text{Sin} f(x)) = \text{Cos} f(x) \cdot \frac{d}{dx} (f(x))$$

$$\text{Eg:-} \quad \frac{d}{dx} (\text{Sin } 3x) = \text{Cos } 3x \cdot \frac{d}{dx} (3x) = \text{Cos } 3x \cdot 3 = 3 \text{Cos } 3x$$

$$* \quad \frac{d}{dx} (\text{Cos} f(x)) = -\text{Sin} f(x) \cdot \frac{d}{dx} (f(x))$$

$$\text{Eg:-} \quad \frac{d}{dx} (\text{Cos } 3x) = -\text{Sin } 3x \cdot \frac{d}{dx} (3x) = -\text{Sin } 3x \cdot 3 = -3 \text{Sin } 3x$$

$$* \quad \frac{d}{dx} (\log f(x)) = \frac{1}{f(x)} \cdot \frac{d}{dx} f(x)$$

$$\text{Eg:-} \quad \frac{d}{dx} (\log \text{Sin} x) = \frac{1}{\text{Sin} x} \cdot \frac{d}{dx} (\text{Sin} x) = \frac{1}{\text{Sin} x} \cdot \text{Cos} x = \tan x$$

$$* \quad \frac{d}{dx} (\text{Sin}^{-1} f(x)) = \frac{1}{\sqrt{1-(f(x))^2}} \cdot \frac{d}{dx} (f(x))$$

$$\text{Eg:-} \quad \frac{d}{dx} (\text{Sin}^{-1} \sqrt{x}) = \frac{1}{\sqrt{1-(\sqrt{x})^2}} \cdot \frac{d}{dx} (\sqrt{x}) = \frac{1}{\sqrt{1-x}} \cdot \frac{1}{2\sqrt{x}} = \frac{1}{2\sqrt{x} \cdot \sqrt{1-x}}$$

$$* \quad \frac{d}{dx}(\text{Cos}^{-1}f(x)) = \frac{-1}{\sqrt{1-(f(x))^2}} \cdot \frac{d}{dx}(f(x))$$

$$\text{Eg:-} \quad \frac{d}{dx}(\text{Cos}^{-1}2x) = \frac{1}{\sqrt{1-(2x)^2}} \cdot \frac{d}{dx}(2x) = \frac{1}{\sqrt{1-4x^2}} \cdot 2 = \frac{2}{\sqrt{1-4x^2}}$$

$$* \quad \frac{d}{dx}(\text{tan}^{-1}f(x)) = \frac{1}{1+(f(x))^2} \cdot \frac{d}{dx}(f(x))$$

$$\text{Eg:-} \quad \frac{d}{dx}(\text{tan}^{-1}3x) = \frac{1}{1+(3x)^2} \cdot \frac{d}{dx}(3x) = \frac{1}{1+9x^2} \cdot 3 = \frac{3}{1+9x^2}$$

$$* \quad \frac{d}{dx}(e^{f(x)}) = e^{f(x)} \cdot \frac{d}{dx}(f(x))$$

$$\text{Eg:-(i)} \quad \frac{d}{dx}(e^{\sqrt{x}}) = e^{\sqrt{x}} \cdot \frac{d}{dx}(\sqrt{x}) = e^{\sqrt{x}} \cdot \frac{1}{2\sqrt{x}}$$

$$\text{(ii)} \quad \frac{d}{dx}(e^{\text{Sin}^{-1}x}) = e^{\text{Sin}^{-1}x} \cdot \frac{d}{dx}(\text{Sin}^{-1}x) = e^{\text{Sin}^{-1}x} \cdot \frac{1}{\sqrt{1-x^2}}$$

Logarithmic Differentiation

This method is usually used to find out the derivative of the function of the form $(f(x))^{g(x)}$ or the product of two or more differentiable functions.

$(f(x))^{g(x)}$ എന്ന രീതിയിലുള്ള ഫങ്ഷനുകളെ ഡിഫറൻഷിയേറ്റ് ചെയ്യുമ്പോൾ ലോഗരിഥിക് ഡെറിവേറ്റീവ് ഉപയോഗിക്കുന്നു. രണ്ടോ അതിലധികമോ ഉള്ള ഫങ്ഷനുകളുടെ പ്രോഡക്ടിനെ ഡിഫറൻഷിയേറ്റ് ചെയ്യുവാനും പ്രസ്തുത രീതി ഉപയോഗിക്കാവുന്നതാണ്.

Procedure

തന്നിരിക്കുന്ന ഫങ്ഷനെ y എന്ന് വിളിക്കുക

ie, $y = f(x)^{g(x)}$ രണ്ട് ഭാഗത്തും ലോഗ് ചെയ്യുക.

ie, $\log y = \log f(x)^{g(x)} = g(x) \cdot \log f(x)$

ഇരുഭാഗങ്ങളിലും ഡിഫറൻഷിയേറ്റ് ചെയ്യുക.

Eg:- Find the derivative of x^x with respect of x .

Solution: Let $y=x^x$

Taking log on both sides.

$$\log y = \log(x^x) \Rightarrow \log y = x \log x \left[\because \log a^n = n \log a \right]$$

Differentiate on both sides with respect x, to get: $\frac{d}{dx}(\log y) = \frac{d}{dx}(x \cdot \log x)$

$$\frac{1}{y} \cdot \frac{dy}{dx} = x \cdot \frac{d}{dx}(\log x) + \log x \frac{d}{dx}(x)$$

$$\Rightarrow \frac{1}{y} \cdot \frac{dy}{dx} = x \cdot \frac{1}{x} + \log x \cdot 1 \Rightarrow \frac{dy}{dx} = y(1 + \log x). \text{ [But } y \text{ is only our assumption] thus,}$$

$$\frac{dy}{dx} = x^x(1 + \log x)$$

Eg:(ii) Find $\frac{dy}{dx} = (\log x)^x$

Solution: Put $y = (\log x)^x$, taking log on both sides, to get:

$$\log y = \log((\log x)^x) \Rightarrow \log y = x \cdot \log(\log x)$$

Differentiating on both sides with respect to x,

$$\frac{1}{y} \cdot \frac{dy}{dx} = \frac{d}{dx}\{x \cdot \log(\log x)\} \Rightarrow \frac{1}{y} \frac{dy}{dx} = \log(\log x) \cdot \frac{d}{dx}(x) + \frac{d}{dx}[\log(\log x)]$$

$$\Rightarrow \frac{1}{y} \cdot \frac{dy}{dx} = x \cdot \frac{1}{\log x} \cdot \frac{1}{x} + \log(\log x) \cdot 1$$

$$\Rightarrow \frac{dy}{dx} = y \left\{ \frac{1}{\log x} + \log(\log x) \right\}; \text{ But } y = (\log x)^x$$

$$\text{Hence } \frac{dy}{dx} = (\log x)^x \left\{ \frac{1}{\log x} + \log(\log x) \right\}$$

$$\text{ie, } \frac{d}{dx}\{(\log x)^x\} = (\log x)^x \left\{ \frac{1}{\log x} + \log(\log x) \right\}$$

Exercise : Find i) $\frac{d}{dx}(x^{1/x})$, ii) $\frac{d}{dx}((\cos x)^{\sin x})$ iii) $\frac{d}{dx}(\log x)^{\log x}$

Parametric Forms

A relation expressed between two variables x and y in the form $x=f(t)$ and $y=g(t)$ is said to

be parametric form with the parameter t.

x, y എന്നീ രണ്ട് വേരിയബിൾ തമ്മിലുള്ള ബന്ധം മൂന്നാമതൊരു പദത്തിൽ പ്രസ്താവിക്കപ്പെടുന്ന രീതിയാണ് പാരാമെട്രിക് ഫോം എന്ന് വിളിക്കുന്നത്, ie, $x = f(t)$ and $y = g(t)$.

Here $\frac{dy}{dx} = \frac{dy/dt}{dx/dt}$ (x & y are in terms of t, thus we can differentiate them only with respect to t.)

Thus in parametric differentiation first we find $\frac{dy}{dt}$ & $\frac{dx}{dt}$, then $\frac{dy}{dx} = \frac{\frac{dy}{dt}}{\frac{dx}{dt}}$

Eg:-i) If $y=2at$ and $x=at^2$. Find $\frac{dy}{dx}$

Here x & y are in parametric form with the parameter t then,

$$\frac{dy}{dt} = \frac{d}{dt}(2at) \text{ \& } \frac{dx}{dt} = \frac{d}{dt}(at^2)$$

$$\text{ie, } \frac{dy}{dt} = 2a \text{ \& } \frac{dx}{dt} = 2at \quad \text{Thus } \frac{dy}{dx} = \frac{\frac{dy}{dt}}{\frac{dx}{dt}} = \frac{2a}{2at} = \frac{1}{t}$$

Eg:-ii) $x=a(\theta - \text{Sin}\theta)$, $y = a(1 + \text{Cos}\theta)$ Find $\frac{dy}{dx}$.

Here x & y are in parametric form with the parameter θ .

$$\text{Then } \frac{dy}{d\theta} = \frac{d}{d\theta}(a(1 + \text{Cos}\theta)) = a \frac{d}{d\theta}(1 + \text{Cos}\theta) = a(-\text{Sin}\theta) = -a\text{Sin}\theta$$

$$\frac{dx}{d\theta} = \frac{d}{d\theta}(a(\theta - \text{Sin}\theta)) = a \frac{d}{d\theta}(\theta - \text{Sin}\theta) = a(1 - \text{Cos}\theta)$$

$$\text{Hence } \frac{dy}{dx} = \frac{\frac{dy}{d\theta}}{\frac{dx}{d\theta}} = \frac{-a\text{Sin}\theta}{a(1 - \text{Cos}\theta)} = \frac{-\text{Sin}\theta}{1 - \text{Cos}\theta}$$

UNIT TEST

Score: 20

Time : 40 minutes

I (Choose the correct answer - 1 score)

- The rate of change of the area of a circle w.r.t to radius when $r=5$ cm is
 - 10π
 - $10\pi \text{ cm}^2 / \text{cm}$
 - $\frac{220}{7}$
 - none of these
- On \mathbb{R} , the function $f(x) = 7x-3$ is
 - Strictly decreasing
 - decreasing
 - Increasing
 - Strictly increasing
- Equation of the normal to the curve $y=\sin x$ at $(0,0)$ is
 - $x=0$
 - $y=0$
 - $x+y=0$
 - $x-y=0$
- The function $f(x)=x$ has
 - only one maximum
 - only one minimum
 - one maximum and one minimum
 - none extreme value
- A car starts from a point P at a time $t=0$ seconds and stops at the point of Q. The distance x , in metres covered by it, in 4 seconds is given by $x = t^2(2 - \frac{t}{3})$. The distance between P and Q is
 - 4m
 - $\frac{32}{3}$
 - 32m
 - none of these

II Answer the following

- A ladder 5m long is leaning against a wall. The bottom of the ladder is pulled along the ground, away from the wall, at the rate of 3cm/sec. How fast is to be height on the wall decreasing when the foot of the ladder is 3m away from the wall? (Score 3)
- Determine the value of x for which $f(x) = x + \frac{1}{x}$ is increasing or decreasing (Score 3)
- Find the equation of the tangent to the curve $\sqrt{x} + \sqrt{y} = a$ at the point $(\frac{a^2}{4}, \frac{a^2}{4})$, $a > 0$ (Score 3)
- If $y = x^3 - 4x$ and x changes from 2 to 1.99, find the appropriate change in the value of y . (Score 2)
- Use differential to approximate the cube root of 66. (Score 2)
- A figure consists of a semi circle with a rectangle on its diameter. Given the perimeter of the figure, find its dimension in order that the area may be maximum. (Score 5)

Answers with Hints

1. b) $A = \pi r^2 cm^2$

$$\frac{dA}{dr} = 2\pi r \text{ cm}^2 / \text{cm}$$

$$\frac{dA}{dr} \Big|_{r=5} = 10\pi \text{ cm}^2 / \text{cm}$$

2. c)

$$f'(x) = 7 > 0$$

\therefore f is strictly increasing

3. c) Slope of the tangent $m = \frac{dy}{dm} = \text{Cos}x$

at (0,0) $m = \text{Cos} \theta = 1$

$$\text{Slope of the normal} = \frac{-1}{m} = -1$$

Formation of the normal

$$y - 0 = -1(x - 0)$$

$$y + x = 0$$

4. d) $f'(x) = 1 > 0$ for all x

ie, f is increasing on R.

5. b) Given $x = t^2 \left(2 - \frac{t}{3} \right) = 2t^2 - \frac{t^3}{3}$

at P and Q, $\frac{dx}{dt} = 0$

$$\frac{dx}{dt} = 0 \Rightarrow 4t - t^2 = 0$$

$$\Rightarrow t(4 - t) = 0$$

$$\Rightarrow t = 0, 4$$

at P, ie at $t=0$ $x = 0$

at Q, ie at $t=4$ $x = \frac{32}{3}$

$$\therefore PQ = \frac{32}{3} m$$

6.

AC the length of the ladder

Given $\frac{dx}{dt} = 3 \text{ cm} / \text{s}$

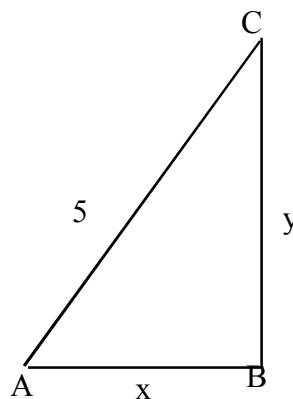

From right triangle ABC, $x^2 + y^2 = 5^2$

$$\therefore y = \sqrt{5^2 - x^2}$$

$$\frac{dy}{dt} = \frac{1}{2\sqrt{5^2 - x^2}} (-2x) \frac{dx}{dt}$$

$$= \frac{-x}{\sqrt{5^2 - x^2}} (3)$$

$$\text{at } x=3 \quad \frac{dy}{dt} = \frac{-3(3)}{\sqrt{5^2 - 3^2}} = \frac{-9}{4}$$

\therefore The height of the wall is decreasing at $\frac{9}{4}$ cm/s

7. Given $f(x) = x + \frac{1}{x}$

$$f'(x) = 1 - \frac{1}{x^2} = \frac{x^2 - 1}{x^2}$$

$$f'(x) > 0 \text{ if } \frac{x^2 - 1}{x^2} > 0 \quad x^2 \neq 0$$

$$\text{ie, if } x^2 - 1 > 0$$

$$\text{ie, if } x^2 > 1$$

$$\text{ie, if } |x| > 1$$

$$\text{ie, if } x < -1 \text{ or } x > 1$$

\therefore f is increasing in $(-\infty, -1) \cup (1, \infty)$

$$f'(x) < 0 \text{ if } \frac{x^2 - 1}{x^2} < 0, \quad x^2 \neq 0$$

$$\text{ie, if } x^2 - 1 < 0, \quad x \neq 0$$

$$\text{ie, if } x^2 < 1 < 0, \quad x \neq 0$$

$$\text{ie, if } |x| < 1 \quad x \neq 0$$

\therefore f is decreasing $(-1, 1) - \{0\}$

8. Given $\sqrt{x} + \sqrt{y} = a$

differentiating w.r.to x

$$\frac{1}{2\sqrt{x}} + \frac{1}{2\sqrt{y}} \frac{dy}{dx} = 0$$

$$\therefore \frac{dy}{dx} = \frac{-\sqrt{y}}{\sqrt{x}}$$

$$\text{at } \left(\frac{a^2}{4}, \frac{a^2}{4} \right), \frac{dy}{dx} = -1$$

\therefore Equation of the tangent at $\left(\frac{a^2}{4}, \frac{a^2}{4} \right)$ is

$$y - \frac{a^2}{4} = -1 \left(x - \frac{a^2}{4} \right)$$

$$\text{ie, } y + x = \frac{a^2}{2} \quad \text{ie } 2(x + y) = a^2$$

9. $y = x^3 - 4x$

$$dy = (3x^2 - 4)dx$$

$$= (3x^2 - 4)(-0.01)$$

$$\text{at } x = 2 \quad dy = (3(2)^2 - 4)(-0.01) \\ = -.08$$

10. $f(x) = x^{1/3}$

$$x = 64 \quad \Delta x = 2$$

$$f(x + \Delta x) = f(x) + \Delta y$$

$$\Delta y = dy = f'(x)dx$$

$$= \frac{1}{3} x^{\frac{1}{3}-1} \Delta x$$

$$= \frac{1}{3} (64)^{-2/3} (2)$$

$$= .041667$$

$$= .042$$

$$\therefore (66)^{1/3} = (64)^{1/3} + .042$$

$$= 4 + .042$$

$$= 4.042$$

11.

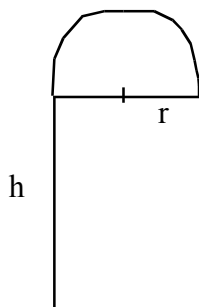

$$\text{Perimeter } P = 2r + 2h + \pi r$$

$$h = \frac{1}{2}(P - r(2 + \pi))$$

$$\text{Area, } A = 2rh + \frac{1}{2}\pi r^2$$

$$= 2r\left(\frac{1}{2}\right)(P - r(2 + \pi)) + \frac{1}{2}\pi r^2$$

$$= Pr - r^2\left(2 + \frac{\pi}{2}\right)$$

$$\frac{dA}{dr} = P - 2r\left(2 + \frac{\pi}{2}\right)$$

$$= P - r(4 + \pi)$$

$$\therefore \frac{dA}{dr} = 0 \Rightarrow r = \frac{P}{4 + \pi}$$

$$\frac{d^2A}{dr^2} = -(4 + \pi) < 0$$

$$\therefore \text{at } r = \frac{P}{4 + \pi}, \text{ Area is maximum}$$

$$h = \frac{1}{2}(P - r(2 + \pi))$$

$$= \frac{1}{2}\left(P - \frac{P}{4 + \pi}(2 + \pi)\right)$$

$$= \frac{P}{4 + \pi}$$

7. APPLICATION OF DERIVATIVES

1. Suppose the radius of a circle changes uniformly with respect to time 't' then find $\frac{dA}{dt}$.

Solution: $A = \pi r^2$, then $\frac{dA}{dt} = \frac{d}{dt}(\pi r^2) = \pi \cdot \frac{d}{dt}(r^2) = \pi \cdot 2r \cdot \frac{dr}{dt}$

Remarks: The volume of a sphere with radius r is $\frac{4}{3}\pi r^3$. Then the uniform change of volume with respect to time t is given by,

$$\frac{dV}{dt} = \frac{d}{dt}\left(\frac{4}{3}\pi r^3\right) = \frac{4}{3}\pi \frac{d}{dt}(r^3) = \frac{4}{3}\pi \cdot 3r^2 \frac{dr}{dt} = 4\pi r^2 \cdot \frac{dr}{dt}$$

Qn: Find the value of $\frac{dA}{dt}$ and $\frac{dv}{dt}$ when $\frac{dr}{dt} = 5$ and $r = 8$

$$\frac{dA}{dt} = \frac{d}{dt}(4\pi r^2) = 8\pi r \frac{dr}{dt} = 8\pi \cdot 8 \cdot 5 = 320\pi$$

$$\frac{dv}{dt} = \frac{d}{dt}\left(\frac{4}{3}\pi r^3\right) = 4\pi r^2 \frac{dr}{dt} = 4\pi \cdot 8^2 \cdot 5 = 1280\pi$$

Remarks

The volume of a cone with base radius r, height h, is given by $V = \frac{1}{3}\pi r^2 h$

$$\text{then } \frac{dV}{dh} = \frac{d}{dh}\left(\frac{1}{3}\pi r^2 h\right) = \frac{1}{3}\pi r^2$$

Eg:-i) The radius of a circle increasing at the rate of 0.5 cm/sec. What is the rate of increase of circumference?

Solution: If 'r' be the radius of a circle, then its circumference is given by $C = 2\pi r$

$$\begin{aligned} \text{then } \frac{dc}{dt} &= \frac{d}{dt}(2\pi r) = 2\pi \frac{dr}{dt} \\ &= 2\pi \times (0.5) \left[\because \text{given } \frac{dr}{dt} = 0.5 \text{ cm / sec} \right] \\ &= \pi \end{aligned}$$

Eg:-ii) The radius of a circular plate is increasing at the rate of 0.4 cm/sec. Find the rate of increase of its area when radius r = 3 cm.

Solution: Let A be the area & r be the radius of a circle at time 't' then $A = \pi r^2$

$$\begin{aligned}
&= \frac{dA}{dt} = \frac{d}{dt}(\pi r^2) = 2\pi r \frac{dr}{dt} \\
&= 2\pi \times 3 \times 4 \left[\because r = 3\text{cm}, \frac{dr}{dt} = .4\text{cm/sec} \right] \\
&= 2.4\pi
\end{aligned}$$

Eg:iii) Find the rate of change of volume of a ball with respect to its radius r. How fast its volume changes when radius is 10cm?

Solution: The ball is spherical in shape. Hence its volume is given by $V = \frac{4}{3}\pi r^3$

$$\begin{aligned}
\text{then, } \frac{dv}{dr} &= \frac{4}{3}\pi \cdot 3r^2 & \left[\because \frac{dv}{dr} = \frac{d}{dr}\left(\frac{4}{3}\pi r^3\right) = \frac{4}{3}\pi \frac{d}{dr}(r^3) \right] &= \frac{4}{3}\pi \cdot 3 \cdot r^2 \\
&= 4\pi r^2 \\
&\text{at } r=10
\end{aligned}$$

$$\frac{dV}{dr} = 4\pi(10)^2 = 400\pi$$

Eg:- iv) A balloon which always remains spherical in shape being inflated by pumping in 900cm³ gas per second. Find the rate at which the radius of the balloon is increasing when radius 15 cm.

Solution: The volume of the sphere $V = \frac{4}{3}\pi r^3$

It is given that $\frac{dv}{dt} = 900\text{cm}^3/\text{sec}$, $r=15\text{cm}$.

$$V = \frac{4}{3}\pi r^3 \Rightarrow \frac{dv}{dt} = \frac{4}{3}\pi \cdot \frac{d}{dt}(r^3) = \frac{4}{3}\pi \cdot 3r^2 \cdot \frac{dr}{dt}$$

$$\text{ie, } \frac{dv}{dt} = 4\pi^2 \cdot \frac{dr}{dt} \Rightarrow 900 = 4\pi \times (15)^2 \cdot \frac{dr}{dt}$$

$$\Rightarrow \frac{dr}{dt} = \frac{900}{4\pi \times 15^2} = \frac{900}{900\pi}$$

$$\Rightarrow \frac{dr}{dt} = \frac{1}{\pi} \text{cm/sec}$$

Review problems

A spherical balloon is being inflated so that its volume increases uniformly at the rate of 400cm³/sec. How fast its surface area increasing when the radius is 8cm?

Rolle's Theorem

Statement: If f is a real values function defined on (a,b) such that,

i) f is continuous on $[a,b]$ ii) f is differentiable on (a,b) , iii) $f(a)=f(b)$

then there exist $c \in (a,b)$ such that $f'(c) = 0$

Working rule

step I: തന്നിരിക്കുന്ന ഫങ്ഷൻ $y=f(x)$ സൂചിപ്പിക്കുന്ന ഇന്റർവെൽ continuous ആണോ എന്ന് പരിശോധിക്കുക.

(ഫങ്ഷൻ പോളിനോമിയൽ ആണെങ്കിൽ പ്രസ്തുത ഫങ്ഷൻ continuous ആണെന്ന് എളുപ്പത്തിൽ പറയാം)

Step II തന്നിരിക്കുന്ന interval (a,b) ആണെങ്കിൽ $f(x)$ ഉം $f(b)$ ഉം കാണുക. ഇത് രണ്ടും തുല്യമാണോ എന്ന് പരിശോധിക്കുക.

Continuity, differentiability, $f(a) = f(b)$ എന്നിവ സ്ഥിരീകരിക്കപ്പെട്ടാൽ ഫങ്ഷൻ Rolles theorem satisfy ചെയ്യുന്നു എന്ന് പറയാം.

Step III: ഫങ്ഷന്റെ ഫസ്റ്റ് ഡെറിവേറ്റീവിനെ (അതായത് $f'(x)$) യുമായി തുല്യനം ചെയ്യുക.

ie, $f'(x) = 0$

x ന്റെ വില a യ്ക്കും b യ്ക്കും ഇടയിലാണെന്ന് കണ്ടെത്തുക.

Eg:-i) Verify Rolle's theorem for $f(x) = x^2 - 6x + 8$ on $(2,4)$

Solution: Since the given is a polynomial function, it is continuous, also it is differentiable, ie, $f'(x)$ exist.

$$f(2) = 2^2 - 6 \cdot 2 + 8 = 4 - 12 + 8 = 0$$

$$f(4) = 4^2 - 6 \cdot 4 + 8 = 16 - 24 + 8 = 0$$

$$\text{ie, } f(2) = f(4)$$

thus $f(x)$ satisfies Rolle's theorem.

Thus by Rolle's theorem $f'(c) = 0$

$$f'(x) = 0 \Rightarrow 2x - 6 = 0$$

$$(\because f(x) = x^2 - 6x + 8)$$

$$\Rightarrow x = \frac{6}{2} = 3$$

$$f'(x) = 2x - 6$$

d $\Rightarrow c = 3 \in (2, 4)$

Hence verified.

Review questions:

- i) Verify Rolle's theorem for $f(x) = x(x-4)$ on $(0,4)$ (Hint: $f(x) = x^2-4x$)
- ii) Verify Rolle's theorem for $f(x) = \cos x - 1$ on $(0, 2\pi)$

Mean Value Theorem (M.V.T)

Statement: If $f(x)$ is a real values function such that

- i) It is continuous on $[a,b]$ ii) it is differentiable on (a,b) then there exists $c \in (a,b)$

such that

$$f'(c) = \frac{f(b) - f(a)}{b - a}$$

Working rule

മുകളിൽ പറഞ്ഞ സ്റ്റേപ്പ് 1, സ്റ്റേപ്പ് 2, എന്നിവ പരിശോധിക്കുക. പ്രസ്തുത സ്റ്റേപ്പുകൾ സാധ്യ കരിക്കപ്പെടുന്നതാണെങ്കിൽ തന്നിരിക്കുന്ന ഫങ്ഷൻ Mean value theorem satisfy ചെയ്യുന്നു എന്ന് പറയാം.

സ്റ്റേപ്പ് 3 : തന്നിരിക്കുന്ന ഇൻ്റർവെൽ (a,b) ആണെങ്കിൽ $f(a)$ ഉം $f(b)$ ഉം കാണുക. തുടർന്ന് $f(x)$ കണ്ടെത്തുക.

By mean value theorem, $f'(x) = \frac{f(b) - f(a)}{b - a}$

Solve ചെയ്ത് ലഭിക്കുന്ന c യുടെ വില (a,b) ൽ ആണെന്ന് കാണാം.

Eg:-i) Verify mean value theorem for $f(x) = 2x-x^2$ on $(0,1)$

Solution: Given $f(x) = 2x-x^2$ on $(0,1)$

Since $2x-x^2$ is a polynomial, it is continuous function.

$f'(x) = 2-2x$, which is exist on $(0,1)$, hence it is differentiable.

thus $f(x)$ satisfies the conditions of M.V.T.

$$f(0) = 2 \times 0 - 0^2 = 0, \quad f(1) = 2 \times 1 - 1^2 = 2 - 1 = 1$$

$f'(x) = 2 - 2x \Rightarrow f'(c) = 2 - 2c$: By mean value theorem.

$$f'(c) = \frac{f(b) - f(a)}{b - a} \Rightarrow 2 - 2c = \frac{1 - 0}{1 - 0} \Rightarrow 2 - 2c = 1 \Rightarrow 2 - 1 = 2c$$

$$\Rightarrow 2c = 1 \Rightarrow c = \frac{1}{2} \in (0, 1)$$

Hence verified.

Review Questions

1. Verify mean value theorem for $f(x) = x^3 + x^2 - 6x$ on $(-1, 4)$
2. Verify mean value theorem for $f(x) = x^2 - 4$ on $(-1, 4)$

Increasing and Decreasing functions

Let f be a function continuous on (a, b) and differentiable on (a, b) then,

- i) f is increasing on (a, b) if $f'(x) \geq 0; \forall x \in (a, b)$
- ii) f is decreasing on (a, b) if $f'(x) \leq 0; \forall x \in (a, b)$
- iii) f is a constant function if $f'(x) = 0; \forall x \in (a, b)$

$y=f(x)$ എന്ന ഫങ്ഷൻ പരിഗണിക്കുക. (a, b) യിൽ ഫങ്ഷൻ continuous ആണെന്ന് കരുതുക. ഫങ്ഷൻ differentiable ആണെന്ന് കരുതുക. പ്രസ്തുത ഫങ്ഷൻ (a, b) ൽ increasing ആണെന്ന് പറയണമെങ്കിൽ $f'(x) \geq 0, \forall x \in (a, b)$

$f'(x) \leq 0, \forall x \in (a, b)$ ആണെങ്കിൽ ഫങ്ഷൻ decreasing ആണെന്ന് പറയാം.

$f'(x) = 0$ ആയാൽ പ്രസ്തുത ഫങ്ഷനെ constant function എന്ന് പറയുന്നു.

Critical value

A value $x = x_0$ is a critical value for the function $f(x)$, if either $f'(x_0) = 0$ or $f'(x_0)$ does not exist.

Eg:-i) Prove that the function $f(x) = x^3 - 3x^2 + 3x - 100$ is increasing on \mathbb{R} .

Solution: $f(x) = x^3 - 3x^2 + 3x - 100$

$$f'(x) = 3x^2 - 6x + 3 = 3(x^2 - 2x + 1)$$

$$= 3(x-1)^2$$

$$\geq 0 \text{ on } \mathbb{R} \left[\because (x-1)^2 \text{ is a perfect square hence it is always } \geq 0 \right]$$

Thus f is increasing on \mathbb{R} .

Review Question

Prove that $f(x) = 4x^3 - 6x^2 + 3x + 12$ is increasing.

Note: If $f'(x) \geq 0$, f is an increasing function. If $f'(x) > 0$, f is **strictly increasing**. Similarly $f'(x) \leq 0$, implies $f(x)$ is decreasing function & $f'(x) < 0 \Rightarrow f$ is **strictly decreasing**.

Eg:- Prove that $f(x) = \sin x$ is

- i) Strictly increasing on $(0, \pi/2)$
- ii) Strictly decreasing on $(\pi/2, \pi)$
- iii) Neither increasing or decreasing on $(0, \pi)$

Solution:

$$f(x) = \sin x$$

$$f'(x) = \cos x$$

- i) For $x \in (0, \pi/2)$, Cosine function is always +ve (in the first quadrant Cosine function is +ve)

ie, $f'(x) > 0$, for all $x \in (0, \pi/2)$ thus $f(x) = \sin x$ is strictly increasing.

- ii) $x \in (\pi/2, \pi)$, ie, x belongs to the second quadrant, Cosine function is negative on second quadrant, hence $\cos x$ is negative in $(\pi/2, \pi)$

ie, $f'(x) < 0$ for all $x \in (\pi/2, \pi) \Rightarrow f(x) = \sin x$ is strictly decreasing.

- iii) From (i) & (ii) it follows that $f(x)$ is neither increasing or decreasing on $(0, \pi)$.

Eg:-ii) Find the intervals on which the function $f(x) = x^4 - 2x^2$ is

- a) Strictly increasing
- b) Strictly decreasing

Solution: $f(x) = x^4 - 2x^2$, $f'(x) = 4x^3 - 4x$

$$\text{Consider } f'(x) = 0 \Rightarrow 4x^3 - 4x = 0 \Rightarrow 4x(x^2 - 1) = 0$$

$$\Rightarrow x = 0 \text{ or } x^2 - 1 = 0 \Rightarrow x = 0 \text{ or } x^2 = 1 \Rightarrow x = \pm 1$$

Thus the critical points are $x = -1, 0, 1$

Use these values of x to divide the domain \mathbb{R} into disjoint open intervals.

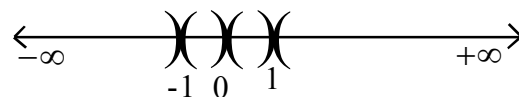

The intervals are

$$(-\infty, -1), (-1, 0), (0, 1) \text{ \& } (1, \infty)$$

Case (i) $x \in (-\infty, -1)$, ie, $-\infty < x < -1$, $f'(x) = 4x^3 - 4x < 0$

$\Rightarrow f(x)$ is strictly decreasing on $(-\infty, -1)$

Case (ii) $x \in (-1,0)$ ie, $-1 < x < 0$.

$f'(x) = 4x^3 - 4x > 0 \Rightarrow f(x)$ is strictly increasing on $(-1,0)$

Case (iii) $x \in (0,1)$ ie, $0 < x < 1$

$f'(x) = 4x^3 - 4x < 0 \Rightarrow f(x)$ is strictly decreasing on $(0,1)$

Case(iv) $x \in (1, \infty)$ ie, $1 < x < \infty$

$f'(x) = 4x^3 - 4x > 0 \Rightarrow f(x)$ is strictly increasing on $(1, \infty)$

Review Questions

- i) Find the intervals on which $f(x) = 2x^3 - 24x + 15$ is increasing or decreasing
- ii) Find the intervals on which $f(x) = 4x^4 - \frac{x^3}{3}$ increasing.

Maximum & Minimum

Working rule for second derivative test

സ്റ്റേപ്പ് 1 : ആദ്യമായി $f'(x)$ ഉം $f''(x)$ ഉം കാണുക.

സ്റ്റേപ്പ് 2 : $f'(x) = 0$ എന്ന സമവാക്യം solve ചെയ്യുക.

സ്റ്റേപ്പ് 3 : x ന്റെ വില 'a' ആണെങ്കിൽ $f'(a)$ കാണുക. $f'(a) < 0$ ആണെങ്കിൽ $x = a$ എന്ന വില f ന്റെ local maxima ആയി അറിയപ്പെടുന്നു. $f(a)$ ആണ് ഫങ്ഷന്റെ maximum value./

$f'(a) > 0$ ആണെങ്കിൽ $x = 0$ എന്ന വില f ന്റെ local minima ആയി അറിയപ്പെടുന്നു. പ്രസ്തുത അവസരത്തിൽ $f(a)$ ആണ് ഫങ്ഷന്റെ മിനിമം value.

Working rule for finding extrema using second derivative test.

Step: i) Find $f'(x)$ and $f''(x)$.

ii) Solve $f'(x) = 0$ for critical values.

iii) if $x = a$ be a critical value, then $f''(x) < 0$, hence f has a local maximum at $x = a$ & $f(a)$ be the local maximum value.

If $f''(a) > 0$ f has a local minimum & $f(a)$ is the local minimum value.

Qn: Find the maximum and minimum of the function $f(x) = x^3 - 6x^2 + 9x + 15$

Solution

$$f'(x) = 3x^2 - 12x + 9$$

$$f''(x) = \frac{d}{dx} (f'(x)) = \frac{d}{dx} (3x^2 - 12x + 9) = 6x - 12$$

Now consider $f'(x) = 0$

$$\Rightarrow 3x^2 - 12x + 9 = 0$$

$$\Rightarrow 3(x^2 - 4x + 3) = 0 \Rightarrow 3(x-1)(x-3) = 0 \Rightarrow x-1 = 0 \quad \text{or} \quad x-3 = 0$$

$$\Rightarrow x = 1 \quad \text{or} \quad x = 3$$

$$f''(1) = 6 \times 1 - 12 = -6 < 0 \quad (\because f''(x) = 6x - 12)$$

ie, When $x=1$, $f''(x) < 0 \Rightarrow f$ has local maximum at $x=1$.

$$\text{Thus the maximum value is } f(1) = 1^3 - (6 \times 1)^2 + (9 \times 1) + 15 = 19$$

$$f''(3) = 6 \times 3 - 12 = 6 > 0$$

ie, when $x=3$, $f''(x) > 0 \Rightarrow f$ has local minimum at $x=3$.

$$\text{Thus the minimum value is } f(3) = 3^3 - 6 \times 3^2 + 9 \times 3 + 15 = 15$$

Ex:-i) Find the local maximum or local minimum of the function $f(x) = \sin^4 x + \cos^4 x$; $0 < x < \frac{\pi}{2}$

(Exercise to the reader)

Eg:- Prove that of all rectangles with a given perimeter, the square has the greatest area.

Solution: Let x be the length, y be the breadth of the rectangle with given perimeter P .

$$\text{Thus } P = 2(x+y) = 2x+2y \Rightarrow y = \frac{P}{2} - x$$

Let A be the area of the rectangle.

$$A = xy$$

$$\Rightarrow A = x \left(\frac{P}{2} - x \right) = \frac{P}{2}x - x^2 \quad (\because y = \frac{P}{2} - x)$$

We have to maximum ise area A .

$$\text{for } \frac{dA}{dx} = \frac{P}{2} - 2x$$

$$\frac{d^2A}{dx^2} = -2$$

$$\text{Consider } \frac{dA}{dx} = 0 \Rightarrow \frac{P}{2} - 2x = 0 \Rightarrow 2x = \frac{P}{2} \Rightarrow x = \frac{P}{4}$$

at $x = \frac{P}{4}$, $\frac{d^2A}{dx^2} = -2 < 0$ Hence by second derivative test A is maximum when $x = \frac{P}{4}$

$$\text{When } x = \frac{P}{4}, y = \frac{P}{2} - \frac{P}{4} = \frac{P}{4}$$

ie, Area is maximum when $x = \frac{P}{4}$ & $y = \frac{P}{4} \Rightarrow x = y \Rightarrow$ the rectangle is a square.

Eg:- Show that of all rectangles with given area, the square has the least perimeter.

Solution: Let x & y be the length & breadth of the given rectangle then area $A=xy \Rightarrow y=\frac{A}{x}$

Let P be the perimeter of the rectangle, then

$$P=2(x+y) = 2x + 2\frac{A}{x} \left(\because y = \frac{A}{x} \right)$$

we have to minimise the perimeter.

for $\frac{dp}{dx} = 2 - \frac{2A}{x^2} \quad \left[\because \frac{d}{dx} \left(2x + \frac{2A}{x} \right) = 2 - 2A \frac{d}{dx} \left(\frac{1}{x} \right) \right]$

$$\frac{d^2p}{dx^2} = \frac{d}{dx} \left(\frac{-2A}{x^2} \right) = -2A \frac{d}{dx} (x^{-2})$$

$$= -2A \cdot (-2) x^{-3} = 4A x^{-3}$$

$$= \frac{4A}{x^3} > 0$$

when $\frac{dp}{dx} = 0 \Rightarrow 2 - \frac{2A}{x^2} = 0 \Rightarrow \frac{2A}{x^2} = 2 \Rightarrow x^2 = A \Rightarrow x = \sqrt{A}$

$$\frac{d^2p}{dx^2} \Bigg|_{x=\sqrt{A}} = \frac{4A}{(\sqrt{A})^3}$$

$$= \frac{4A}{A\sqrt{A}} = \frac{4}{\sqrt{A}} > 0 \quad \text{ie, } \frac{d^2p}{dx^2} > 0 \text{ at } x = \sqrt{A}$$

Hence by second derivative test, perimeter is minimum at $x = \sqrt{A}$

When $x = \sqrt{A}$, $y = \frac{A}{\sqrt{A}} \left(\because y = \frac{A}{x} \right) \Rightarrow y = \sqrt{A}$

thus $x=y=\sqrt{A} \Rightarrow$ the rectangle is a square,

Eg:- Find two positive numbers whose sum is 24 & their product is maximum.

Solution: Let the numbers are x and y

Given that $x+y = 24 \Rightarrow y=24-x$

Let the product $p = xy = x(24-x) = 24x-x^2$

we have to maximise p .

For $\frac{dp}{dx} = 0 \Rightarrow 24 - 2x, \frac{d^2p}{dx^2} = -2$

$$\frac{dp}{dx} = 0 \Rightarrow 24 - 2x = 0 \Rightarrow x = 12$$

$$\frac{d^2p}{dx^2} \Big|_{x=12} = -12, < 0 \quad \text{Hence by second derivative test P is maximum at } x=12.$$

$$\text{When } x=12, y=24-x=24-12=12$$

Thus the numbers are 12 and 12.

Eg:- Show that the semivertical angle of the cone of maximum volume and of the given slant height is $\tan^{-1} \sqrt{2}$

Solution: The volume of a cone with height & base radius r is given by $V = \frac{1}{3} \pi r^2 h$

Let ' θ ' be the semi vertical angle,

' ℓ ' be the slant height, h be the height,

r be the base radius of the cone. From figure

$$\sin \theta = \frac{r}{\ell} \Rightarrow r = \ell \sin \theta \quad \& \quad \cos \theta = \frac{h}{\ell} \Rightarrow h = \ell \cos \theta$$

$$\text{Volume } V = \frac{1}{3} \pi r^2 h = \frac{1}{3} \pi [(\ell \sin \theta)^2 \times (\ell \cos \theta)]$$

$$V = \frac{1}{3} \pi \ell^3 \sin^2 \theta \cos \theta$$

We have to maximise the volume V .

For

$$\frac{dv}{d\theta} = \frac{1}{3} \pi \ell^3 [(\sin^2 \theta (-\sin \theta) + \cos \theta \cdot 2 \sin \theta \cos \theta)] \quad (\text{using product rule})$$

$$= \frac{1}{3} \pi \ell^3 [\sin^3 \theta + 2 \cos^2 \theta \cdot \sin \theta]$$

$$\frac{dv}{d\theta} = 0 \Rightarrow (-\sin^3 \theta + 2 \sin \theta \cos^2 \theta) = 0 \quad \left(\because \frac{1}{3} \pi \ell^3 \neq 0 \right)$$

$$\Rightarrow \sin \theta (-\sin^2 \theta + 2 \cos^2 \theta) = 0$$

$$\Rightarrow \sin \theta = 0 \quad \text{or} \quad -\sin^2 \theta + 2 \cos^2 \theta = 0$$

$$\Rightarrow -\sin^2 \theta + 2 \cos^2 \theta = 0 \quad (\because \sin \theta = 0 \Rightarrow \theta = 0, \text{ not possible})$$

$$\Rightarrow \sin^2 \theta = 2 \cos^2 \theta \Rightarrow \tan^2 \theta = 2 \Rightarrow \tan \theta = \sqrt{2} \Rightarrow \theta = \tan^{-1} \sqrt{2}$$

$$\frac{d^2v}{d\theta^2} \text{ is negative for } \theta = \tan^{-1} \sqrt{2}$$

Hence the result.

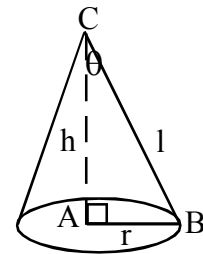

$$\sin^2 \theta = 2 \cos^2 \theta$$

$$\Rightarrow \frac{\sin^2 \theta}{\cos^2 \theta} = 2$$

$$\Rightarrow \tan^2 \theta = 2$$

8. INTEGRATION

Antiderivative and indefinite integration

$F'(x) = f(x)$ എങ്കിൽ $F(x)$ നെ $f(x)$ ന്റെ Antiderivative എന്നു വിളിക്കുന്നു.

എന്നാൽ $F'(x) = f(x)$ ആകുന്ന ഒരേയൊരു $F(x)$ അല്ല ഉള്ളത്. എല്ലാ antiderivatives ന്റെയും സെറ്റിനെ $\int f(x)dx$ കൊണ്ടു സൂചിപ്പിക്കുന്നു. f നെ integrand എന്നും x നെ variable of integration എന്നും വിളിക്കുന്നു.

$f(x)$ ന്റെ antiderivative ആണ് $f(x)$ എങ്കിൽ

$$\int f(x)dx = F(x) + c, \text{ C യെ Integration ന്റെ constant എന്നു വിളിക്കുന്നു.}$$

Standard Results

$$1. \int x^n dx = \frac{x^{n+1}}{n+1} + C$$

$$2. \int dx = x + C$$

$$3. \int \cos x dx = \sin x + C$$

$$4. \int \sin x dx = -\cos x + C$$

$$5. \int \sec^2 x dx = \tan x + C$$

$$6. \int \operatorname{cosec}^2 x dx = -\cot x + C$$

$$7. \int \sec x \tan x dx = \sec x + C$$

$$8. \int \operatorname{cosec} x \cot x dx = -\operatorname{cosec} x + C$$

$$9. \int \frac{dx}{\sqrt{1-x^2}} = \sin^{-1}(x) + C$$

$$= -\cos^{-1}(x) + C$$

$$10. \int \frac{1}{1+x^2} dx = \tan^{-1}(x) + C$$

$$= -\cot^{-1}(x) + C$$

$$11. \int \frac{dx}{\sqrt{x^2-1}} dx = \sec^{-1}(x) + C$$

$$= \operatorname{cosec}^{-1}(x) + C$$

$$12. \int e^x dx = e^x + C$$

$$13. \int \frac{1}{x} dx = \log|x| + C$$

Integration ന് സഹായിക്കുന്ന ചില നിയമങ്ങൾ

1. $\int (f(x) + g(x)) dx = \int f(x) dx + \int g(x) dx$
2. $\int (f(x) - g(x)) dx = \int f(x) dx - \int g(x) dx$
3. $\int kf(x) dx = k \int f(x) dx$

ഓർമ്മിച്ചുവെക്കേണ്ട ചില റിസൾട്ടുകൾ

1. $\int 1 dx = x + c$
2. $\int x dx = \frac{x^2}{2} + c$
3. $\int x^2 dx = \frac{x^3}{3} + C$
4. $\int \sqrt{x} dx = \frac{2}{3} x^{3/2} + C$
5. $\int \frac{1}{\sqrt{x}} dx = 2\sqrt{x} + C$
6. $\int \frac{1}{x} dx = \log|x| + C$
7. $\int \frac{1}{x^2} dx = \frac{-1}{x} + C$

Integration ന് സഹായിക്കുന്ന trigonometric identities

1. $\cos^2 x = \frac{1 + \cos 2x}{2}$
2. $\sin^2 x = \frac{1 - \cos 2x}{2}$
3. $\cos^3 x = \frac{\cos 3x - 3\cos x}{4}$
4. $\sin^3 x = \frac{3 \sin x - \sin 3x}{4}$
5. $\sin x \cos y = \frac{1}{2} [\sin(x+y) + \sin(x-y)]$
6. $\cos x \cos y = \frac{1}{2} [\cos(x-y) + \cos(x+y)]$

Integration ന് സഹായിക്കുന്ന ചില formula കൾ

1. $\int \frac{dx}{x^2 - a^2} = \frac{1}{2a} \log \left| \frac{x-a}{x+a} \right| + C$

2. $\int \frac{dx}{a^2 - x^2} = \frac{1}{2a} \log \left| \frac{a+x}{a-x} \right| + C$

3. $\int \frac{dx}{x^2 + a^2} = \frac{1}{a} \tan^{-1} \left(\frac{x}{a} \right) + C$

4. $\int \frac{dx}{\sqrt{x^2 - a^2}} = \log \left| x + \sqrt{x^2 - a^2} \right| + C$

5. $\int \frac{dx}{\sqrt{a^2 - x^2}} = \sin^{-1} \left(\frac{x}{a} \right) + C$

6. $\int \frac{dx}{\sqrt{x^2 + a^2}} = \log \left| x + \sqrt{x^2 + a^2} \right| + C$

പരിശീലനം I - Integrate the following with respect to x.

1) $2x$

2) x^2

3) $x^2 - 2x + 1$

4) $6x$

5) x^y

6) x^4

7) $\frac{3}{2} \sqrt{x}$

8) $\frac{1}{3} x^{\frac{-2}{3}}$

II - Find the following integrals

9) $\int \frac{-3}{2} x^{\frac{-5}{2}} dx$

10) $\int 3 \sin x dx$

11) $\int \left(\frac{\sqrt{x}}{2} + \frac{2}{\sqrt{x}} \right) dx$

12) $\int (x + \sqrt[3]{x}) dx$

13) $\int \left(\frac{x\sqrt{x} + \sqrt{x}}{x^2} \right) dx$

14) $\int \left(\frac{4 + \sqrt{x}}{x^3} \right) dx$

15) $\int (1 - x^2 - 3x^5) dx$

16) $\int \left(\frac{1}{x^2} - x^2 - \frac{1}{3} \right) dx$

Substitution ഉപയോഗിച്ചുള്ള Integration

$\int f(x) dx$ ചില അവസരങ്ങളിൽ എളുപ്പത്തിൽ കണ്ടുപിടിക്കാൻ ഉചിതമായ substitution സഹായിക്കും.

ശ്രദ്ധിക്കേണ്ട കാര്യങ്ങൾ

Integrand ൽ ഒരു factor ന്റെ derivative മറ്റൊരു factor ആയി ഉണ്ടെങ്കിൽ ആദ്യത്തെ factor നെ substitute ചെയ്യുക.

Eg :-(1) $\int \frac{2x}{1+x^2} dx$

$1+x^2$ ന്റെ derivative $2x$ integrand ന്റെ ഒരു ഘടകമായതിനാൽ $1+x^2=u$ എന്ന് substitute ചെയ്യുക.

എങ്കിൽ $2xdx=du$ എന്ന് കിട്ടും.

$$\begin{aligned} \therefore \int \frac{2x}{1+x^2} dx &= \int \frac{du}{u} = \log |u| + C \\ &= \log |1+x^2| + C \end{aligned}$$

Eg:- (2) $\int \frac{(\log x)}{x} dx$

$\log x$ ന്റെ derivative $\frac{1}{x}$ ഒരു ഘടകമായതിനാൽ $\log x = u$ എന്ന് substitute ചെയ്യുക.

അപ്പോൾ $\frac{1}{x} dx = du$

$$\begin{aligned} \therefore \int \frac{\log x}{x} dx &= \int \log x \frac{1}{x} dx \\ &= \int u du = \frac{u^2}{2} + C \\ &= \frac{(\log x)^2}{2} + C \end{aligned}$$

Eg:-(3) $\int \frac{\tan^{-1}(x)}{1+x^2} dx$

$\tan^{-1}x$ ന്റെ derivative $\frac{1}{1+x^2}$ ഒരു ഘടകമായതിനാൽ $\tan^{-1}(x)=u$ എന്ന് substitute ചെയ്യുക.

അപ്പോൾ $\frac{1}{1+x^2} dx = du$ എന്ന് കിട്ടും.

$$\begin{aligned} \therefore \int \frac{\tan^{-1}(x)}{1+x^2} dx &= \int \tan^{-1}(x) \frac{1}{1+x^2} dx \\ \int u du &= \frac{u^2}{2} + C \\ &= \frac{(\tan^{-1}(x))^2}{2} + C \end{aligned}$$

Partial Fraction ഉപയോഗിച്ചുള്ള Integration

Rational function integrate ചെയ്യാൻ partial fraction ആക്കിയതിനു ശേഷമാണ് Integrate ചെയ്യേണ്ടത്.

ഏതൊരു rational function നും എളുപ്പത്തിൽ integrate ചെയ്യാനാവുന്ന rational function ന്റെ തുകയായി എഴുതുന്നതിനെയാണ് Partial Fraction രീതി എന്നു പറയുന്നത്.

ഇനി പറയുന്ന രീതിയിലാണ് rational function, partial fraction ആയി വിഭജിക്കുന്നത്.

$$1. \frac{px + q}{(x-a)(x-b)} = \frac{A}{x-a} + \frac{B}{x-b}$$

$$2. \frac{px + q}{(x-a)^2} = \frac{A}{x-a} + \frac{B}{(x-a)^2}$$

$$3. \frac{px^2 + qx + r}{(x-a)(x-b)(x-c)} = \frac{A}{x-a} + \frac{B}{x-b} + \frac{C}{x-c}$$

$$4. \frac{px^2 + qx + r}{(x-a)(x^2 + bx + C)} = \frac{A}{x-a} + \frac{Bx + C}{x^2 + bx + C}$$

ഉദാ:- $\int \frac{x}{(x-1)(x-2)} dx$

$$\frac{x}{(x-1)(x-2)} = \frac{A}{x-1} + \frac{B}{x-2} \text{ എന്നു കരുതിയാൽ}$$

$$\frac{x}{(x-1)(x-2)} = \frac{A(x-2) + B(x-1)}{(x-1)(x-2)} \text{ എന്നു കിട്ടും.}$$

ഛേദങ്ങൾ സമാനമായതിനാൽ അംശങ്ങൾ തുല്യമാവണം.

$$\therefore A(x-2) + B(x-1) = x \dots \dots \dots (1)$$

Eqn (1) ൽ x=1 കൊടുത്താൽ

$$A(1-2) + B(0) = 1$$

$$A(-1) = 1$$

$$-A = 1$$

$$A = -1$$

Eqn (1) ൽ x=2 കൊടുത്താൽ

$$A(0) + B(2-1) = 2 \Rightarrow B=2$$

$$\therefore \frac{x}{(x-1)(x-2)} = \frac{-1}{x-1} + \frac{2}{x-2}$$

$$\therefore \int \frac{x}{(x-1)(x-2)} dx = \int \left(\frac{-1}{x-1} + \frac{2}{x-2} \right) dx$$

$$\begin{aligned}
&= \int \frac{-1}{x-1} dx + \int \frac{2}{x-2} dx \\
&= -1 \int \frac{-1}{x-1} dx + 2 \int \frac{1}{x-2} dx \\
&= -1 \log|x-1| + 2 \log|x-2| + C \\
&= -1 \log|x-1| + \log|(x-2)^2| + C \\
&= \log|(x-2)^2| - \log|(x-1)| + C \\
&= \log \left| \frac{(x-2)^2}{(x-1)} \right| + C
\end{aligned}$$

പരിശീലനം

Integrate the following with respect to x.

1. (a) $\frac{x+5}{(x-4)(x+3)}$ (b) $\frac{4}{(2x+3)(4x+5)}$ (c) $\frac{1}{(x+1)(x+2)}$
2. (a) $\frac{x}{(x-3)^2}$ (b) $\frac{2x}{(x+1)^2}$ (c) $\frac{2}{(x+3)^2}$
3. (a) $\frac{1}{(x-1)(x-2)(x-3)}$ (b) $\frac{2x}{(x+1)(x+2)(x+3)}$ (c) $\frac{2}{(x+5)(x+4)(x-7)}$
4. (a) $\frac{1}{(x^2+x+1)(x-1)}$ (b) $\frac{2x}{(x^2+2x+7)(x+1)}$ (c) $\frac{2}{(x^2+3x+7)(x-3)}$

Integration by parts

Integrand രണ്ടു functions ന്റെ product ആണെങ്കിൽ integration by parts ഉപയോഗിച്ച് integrate ചെയ്യാം.

$$\int (f(x)g(x)) dx = f(x) \int g(x) dx - \int \left[\frac{d}{dx} f(x) \cdot \int g(x) dx \right] dx$$

ശ്രദ്ധിക്കേണ്ടത്

തന്നിരിക്കുന്ന product ന്റെ ഒന്നാമത്തെ ഘടകം differentiate ചെയ്യാൻ കഴിയുന്നതും രണ്ടാമത്തെ ഘടകം integrate ചെയ്യാൻ കഴിയുന്നതും ആയിരിക്കണം. Integrate ചെയ്തു കഴിയുമ്പോൾ വലതുഭാഗത്തുള്ള integral കുറച്ചുകൂടി പ്രയാസമുള്ളതാണെങ്കിൽ ഒന്നാമത്തെയും രണ്ടാമത്തെയും function പരസ്പരം മാറ്റുക.

ILATE Rule

Integration by parts ഉപയോഗിച്ച് integrate ചെയ്യുമ്പോൾ ഇനി പറയുന്ന ക്രമത്തിൽ

ഒന്നാമത്തെ function തെരഞ്ഞെടുക്കാവുന്നതാണ്.

1. Inverse trigonometric function 2. Logarithmic function 3. Algebraic function 4. Trigonometric function 5. Exponential function ie, I, L, A, T, E.

$$\begin{aligned} \int x \sin x dx &= x \int \sin x dx - \int \left(\frac{d}{dx}(x) \cdot \int \sin x dx \right) dx \\ &= x(-\cos x) - \int 1 \cdot (-\cos x) dx \\ &= -x \cos x + \int \cos x dx \\ &= -x \cos x + \sin x + C \end{aligned}$$

പരിശീലനം

Find the following integrals

1. $\int x \sin x dx$
2. $\int x^2 \cos x dx$
3. $\int x \log x . dx$
4. $\int \tan^{-1}(x) dx$
5. $\int x \sec x^2 x dx$
6. $\int x^3 e^x dx$
7. $\int (x^2 - 5x) e^x dx$
8. $\int x^5 e^x dx$

Definite Integral

$\int_a^b f(x) dx$ ന്റെ ജ്യോമിതീയ ആശയം
 $y=f(x)$ ന്റെ ഗ്രാഫ് പരിഗണിക്കുക.

$x=a$ യും $x=b$ യും രണ്ട് ലംബങ്ങളാണ്.

$\int_a^b f(x) dx$ എന്നാൽ $y=f(x)$ എന്ന curve, x axis, $x=a$, $x=b$ എന്നീ ലംബങ്ങൾ ഇവ നിർണ്ണയിക്കുന്ന സംവൃതരൂപത്തിന്റെ വിസ്തീർണ്ണമാണ്.

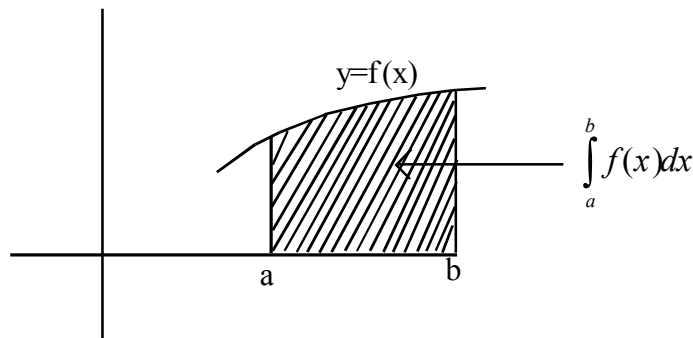

ചതുരങ്ങളുടെ തുകയുടെ limit ആയി definite integral കാണുന്നവിധം.

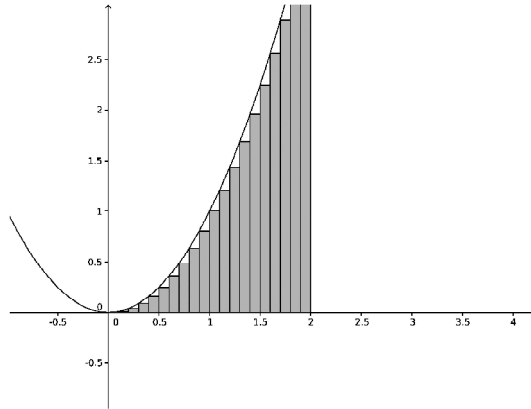

$$\int_a^b f(x)dx = \lim_{h \rightarrow 0} h(f(a) + f(a+h) + \dots + f(a+(n-1)h))$$

$h = \frac{b-a}{n}$ എന്നത് ഓരോ ചതുരത്തിന്റെയും വീതിയാണ് n - ചതുരങ്ങളുടെ എണ്ണം.

സഹായകരമായ ചില തുകകൾ

1) $1+2+3+\dots+n = \frac{n(n+1)}{2}$

2) $1^2+2^2+3^2+\dots+n^2 = \frac{n(n+1)(2n+1)}{6}$

3) $1^3+2^3+\dots+n^3 = \left[\frac{n(n+1)}{2}\right]^2$

ഉദാ: $\int_1^2 x dx$ കാണുക.

ഇവിടെ $a=1, b=2, f(x) = x$ ഉം ആണ്.

$$h = \frac{b-a}{n} = \frac{2-1}{n} = \frac{1}{n}$$

$$f(a) = f(1) = 1$$

$$f(a+h) = f(1+h) = 1+h$$

$$\therefore f((a+(n-1)h) = f(1+(n-1)h) = 1+(n-1)h$$

$$\therefore \int_1^2 x dx = \lim_{h \rightarrow 0} h(f(a) + f(x+h) + \dots + f(a+(n-1)h))$$

$$\lim_{h \rightarrow 0} \frac{1}{n} (1 + (1+h) + (1+2h) + \dots + (1+(n-1)h))$$

$$\lim_{h \rightarrow 0} \frac{1}{n} [(1+1+\dots+1) + h + 2h + \dots + (n-1)h]$$

n തവണ n തവണ

$$= \lim_{h \rightarrow 0} \frac{1}{n} [n + h(1+2+\dots+(n-1))]$$

$$= \lim_{h \rightarrow 0} \frac{1}{n} \left[n + h \frac{n(n-1)}{2} \right]$$

$$= \lim_{h \rightarrow 0} \frac{1}{n} \left[n + \frac{(n-1)}{2} \right] \quad (nh=1)$$

$$= \lim_{h \rightarrow 0} \frac{1}{n} \left[\frac{2n + (n-1)}{2} \right]$$

$$= \lim_{h \rightarrow 0} \frac{1}{n} \left[\frac{3n-1}{2} \right] = \lim_{h \rightarrow 0} \frac{1}{2} \left[3 - \frac{1}{n} \right]$$

$$= \lim_{h \rightarrow 0} \frac{1}{2} [3-h] = \frac{1}{2} [3-0] = \frac{3}{2}$$

I. Choose the correct answer (1 score)

1. $\int \frac{x-1}{x(x-\log x)} dx =$

- a) $\frac{1}{x-\log x} + c$ b) $\log(x-\log x) + c$ c) $\log|x-\log x| + c$ d) none of these

2. $\int \frac{1-\cos 2x}{1+\cos 2x} dx =$

- a) $\tan x - x + c$ b) $x + \tan x + c$ c) $x - \tan x + c$ d) $-x - \cot x + c$

3. $\int_{-1}^1 \frac{|x+2|}{x+2} dx =$

- a) 1 b) 2 c) 0 d) -1

4. $\int_0^a \frac{\sqrt{x}}{\sqrt{x} + \sqrt{a-x}} dx =$

- a) 1 b) $\frac{a}{2}$ c) 2a d) 0

5. If $f(x) = f(a-x)$, then

$$\int_0^a xf(x) dx =$$

- a) $\int_0^a f(x) dx$ b) $\int_0^a f(a-x) dx$ c) $\frac{a}{2} \int_0^a f(x) dx$ d) $\frac{-a}{2} \int_0^a f(x) dx$

II Answer the following

6. Evaluate $\int x \log x (\log x - 1) dx$ (Score 2)

7. Evaluate $\int \frac{1+x}{x^2+2x-3} dx$ (Score 2)

8. Evaluate $\int x e^{3x} dx$ (Score 3)

9. Evaluate $\int \frac{1}{2x^2-x-1} dx$ (Score 3)

10. Evaluate $\int \frac{3x+1}{(x-2)^2(x+2)} dx$ (Score 3)

11. Evaluate $\int_1^2 (x^2-1) dx$ as the limit of a sum (Score 3)

Answers and hints

1. (c) Put $x - \log x = x$
2. $1 - \cos 2x = 2\sin^2 x$ and $1 + \cos^2 x = 2\cos^2 x$
3. If $-1 < x < 1$, $2 + -1 < x + 2 < 3$

$$\text{ie, } 1 < x + 2 < 3$$

$$\text{ie, } x + 2 > 0$$

$$\therefore |x + 2| = x + 2 \text{ in } -1 < x < 1$$

$$4. \quad (b) \quad \int_0^a f(x) dx = \int_0^a f(a-x) dx$$

$$5. \quad (c) \quad I = \int_0^a x f(x) dx \dots\dots\dots(1)$$

$$\text{then } I = \int_0^a (a-x) f(a-x) dx$$

$$= \int_0^a (a-x) f(x) dx \dots\dots(2) \text{ as } f(a-x) = f(x)$$

$$(1) + (2) \rightarrow 2I = \int_0^a a f(x) dx$$

$$\therefore I = \frac{a}{2} \int_0^a f(x) dx$$

$$6. \quad \int x \log x (\log x - 1) dx = \int \log x (x \log x - x) dx \quad \text{Put } x \log x - x = x$$

$$= \frac{(x \log x - x)^2}{2} + 1$$

$$7. \quad \int \frac{1+x}{x^2+2x-3} dx = \frac{1}{2} \int \frac{2x+2}{x^2+2x-3} dx$$

$$= \frac{1}{2} \log|x^2+2x-3| + C$$

$$8. \quad \int x e^{3x} dx = x \int e^{3x} dx - \int \left(\frac{d}{dx}(x) \int e^{3x} dx \right) dx$$

$$= x \frac{e^{3x}}{3} - \int \left(\int e^{3x} dx \right) dx$$

$$= x \frac{e^{3x}}{3} - \int \frac{e^{3x}}{3} dx$$

$$= x \frac{e^{3x}}{3} - \frac{1}{3} \frac{e^{3x}}{3} + C$$

$$= e^{3x} \left(\frac{x}{3} - \frac{1}{9} \right) + C$$

9.
$$\int \frac{1}{2x^2 - x - 1} dx$$

$$= \frac{1}{2} \int \frac{1}{\left(x^2 - \frac{x}{2} - \frac{1}{2}\right)} dx$$

$$= \frac{1}{2} \int \frac{1}{x^2 - 2\left(\frac{x}{4}\right) + \frac{1}{16} - \frac{1}{2} - \frac{1}{16}} dx$$

$$= \frac{1}{2} \int \frac{1}{\left(x - \frac{1}{4}\right)^2 - \frac{9}{16}} dx$$

$$= \frac{1}{2} \int \frac{1}{\left(x - \frac{1}{4}\right)^2 - \left(\frac{3}{4}\right)^2} dx$$

$$= \frac{1}{2} \cdot \frac{1}{2x \frac{3}{4}} \log \left| \frac{x - \frac{1}{4} - \frac{3}{4}}{x - \frac{1}{4} + \frac{3}{4}} \right| + C$$

$$= \frac{1}{3} \log \left| \frac{2(x-1)}{2x-1} \right| + C$$

10. Let
$$\frac{3x+1}{(x-2)^2(x+2)} = \frac{A}{(x-2)} + \frac{B}{(x-2)^2} + \frac{C}{(x+2)}$$

Then $A(x-2)(x+2) + B(x+2) + C(x-2)^2 = 3x+1$(1)

Put $x = 2$, we get $B(2+2) = 7 \Rightarrow B = \frac{7}{4}$

Put $x = -2$, we get

$$C(-4)^2 = -5 \Rightarrow C = \frac{-5}{16}$$

Compare the coeff of x^2 we get

$$A+C=0$$

$$\therefore A=-C=\frac{5}{16}$$

$$\begin{aligned} \therefore \int \frac{3x+1}{(x-2)^2(x+2)} dx &= \frac{5}{16} \int \frac{1}{(x-2)} dx + \frac{7}{4} \int \frac{1}{(x-2)^2} dx + \frac{-5}{16} \int \frac{1}{(x+2)} dx \\ &= \frac{5}{16} \log|x-2| + \frac{7}{4} \frac{(x-2)^{-1}}{-1} - \frac{5}{16} \log|x+2| + C \\ &= \frac{5}{16} \log \left| \frac{(x-2)}{(x+2)} \right| - \frac{7}{4} \frac{1}{(x-2)} + C \end{aligned}$$

11. $f(x) = (x^2 - 1)$

$a=1, \quad b=2$

$$n = \frac{b-a}{h} = \frac{2-1}{h} = \frac{1}{h} \quad \therefore nh = 1$$

$$\int_a^b f(x) dx = \lim_{h \rightarrow 0} (f(a) + f(a+h) + \dots + f(a+(n-1)h))$$

$$\therefore \int_1^2 f(x) dx = \lim_{h \rightarrow 0} h (f(1) + f(1+h) + \dots + f(1+(n-1)h))$$

$$= \lim_{h \rightarrow 0} h [1^2 - 1 + (1+h)^2 - 1 + \dots + (1+(n-1)h)^2 - 1]$$

$$= \lim_{h \rightarrow 0} h [1^2 + (1+h)^2 + \dots + (1+(n-1)h)^2 - n]$$

$$= \lim_{h \rightarrow 0} h [1^2 + 1^2 + \dots + 1^2 + 2h + 2(2h) + 2(3h) + \dots + 2(n-1)h + h^2 + (2h^2) + \dots + ((n-1)h)^2 - n]$$

$$= \lim_{h \rightarrow 0} h \left[n + 2h(1+2+\dots+(n-1)) + h^2(1^2+2^2+\dots+(n-1)^2) - n \right]$$

$$= \lim_{h \rightarrow 0} h \left[\frac{2h(n-1)(n)}{2} + \frac{h^2(n-1)n(2n-1)}{6} \right]$$

$$= \lim_{h \rightarrow 0} h \left[\frac{2nh(n-1)}{2} + \frac{h^2 n^2 \left(1 - \frac{1}{n}\right) (2n-1)}{6} \right]$$

$$\begin{aligned}
&= \lim_{h \rightarrow 0} h \left[(n-1) + \frac{(1-h)n \left(2 - \frac{1}{n} \right)}{6} \right] \\
&= \lim_{h \rightarrow 0} h \left[n \left(1 - \frac{1}{n} \right) + \frac{n(1-h)(2-h)}{6} \right] \\
&= \lim_{h \rightarrow 0} \left[nh(1-h) + \frac{nh(1-h)(2-h)}{6} \right] \\
&= 1 + \frac{1 \cdot 2}{6} = 1 + \frac{1}{3} = \frac{4}{3}
\end{aligned}$$

11. DIFFERENTIAL EQUATIONS

Derivatives ഉള്ള സമവാക്യങ്ങളെയാണ് differential equation എന്ന് വിളിക്കുന്നത്.

ഒരു ഡിഫറൻഷ്യൽ ഇക്വേഷന്റെ ഓർഡർ

ഒരു ഡിഫറൻഷ്യൽ ഇക്വേഷനിൽ ഒന്നോ അതിലധികമോ ഓർഡറുള്ള derivative ഉണ്ടാകാം. എല്ലാ derivative ന്റെയും ഓർഡർ പരിഗണിക്കുക. ഏറ്റവും ഉയർന്ന ഓർഡറുള്ള derivative ന്റെ ഓർഡറായിരിക്കും differential equation ന്റെ ഓർഡർ.

ഉദാ:-
$$\left(\frac{d^3y}{dx^3}\right) - x^2 \left(\frac{d^2y}{dx^2}\right)^3 = 0$$

$\frac{d^2y}{dx^2}$ ന്റെ ഓർഡർ 2

$\frac{d^3y}{dx^3}$ ന്റെ ഓർഡർ 3

∴ differential equation ന്റെ ഓർഡർ 3.

ഡിഗ്രി(ക്യൂതി)

ഏറ്റവും ഉയർന്ന ഓർഡറുള്ള derivative ന്റെ ക്യൂതിയാണ് differential equation ന്റെ ഡിഗ്രി (ക്യൂതി)

ഉദാ:-
$$\frac{d^3y}{dx^3} + 2\left(\frac{d^2y}{dx^2}\right)^2 - \frac{dy}{dx}xy = 0$$

ഏറ്റവും ഉയർന്ന ഓർഡറുള്ള derivative $\frac{d^3y}{dx^3}$ ആണ്.

$\frac{d^3y}{dx^3}$ ന്റെ ക്യൂതി 1 ആണ്. അതുകൊണ്ട് d.e. അതുകൊണ്ട് d.e. ക്യൂതി 1 ആണ്.

പരിശീലനം

ഡിഗ്രിയും ഓർഡറും കാണുക.

1.
$$\frac{d^3y}{dx^3} + \left(\frac{d^2y}{dx^2}\right)^4 + \left(\frac{dy}{dx}\right)^3 + y = 0$$

2.
$$\left(\frac{d^2y}{dx^2}\right)^3 + \left(\frac{dy}{dx}\right)^4 + y^5 = 0$$

3.
$$2x^2 \frac{d^2y}{dx^2} - \frac{3dy}{dx} + y = 0$$

4. $y' + y = e^x$
5. $y'' + (y') + 2y = 0$
6. $y'' + 2y' + \sin y = 0$

Formation of differential equations

തന്നിരിക്കുന്ന family of curves ന്റെ order പരിഗണിക്കുക. അതിലെ parameter നെ eliminate ചെയ്തു കൊണ്ട് parameter ന്റെ എണ്ണം order ആയി വരുന്ന രീതിയിൽ differential equations ഉണ്ടാക്കുക.

ഉദാ:- $y=mx$ എന്ന family of straight line ന്റെ differential equation ഉണ്ടാക്കുക.

Sol: തന്നിരിക്കുന്ന equation ൽ m ആണ് parameter. 'm' eliminate ചെയ്യാൻ തന്നിരിക്കുന്ന equation

differentiate ചെയ്യുക. അപ്പോൾ $\frac{dy}{dx} = m$ എന്നു കിട്ടുന്നു.

m നുപകരം $\frac{dy}{dx}$ കൊടുത്താൽ $y = \frac{dy}{dx} x$ എന്നുകിട്ടുന്നു.

അപ്പോൾ $x \frac{dy}{dx} - y = 0$ എന്നുകിട്ടുന്നു.

കിട്ടിയ equation ആണ് $y=mx$ നെ പ്രതിനിധാനം ചെയ്യുന്ന differential equation

2. $\frac{x^2}{a^2} + \frac{y^2}{b^2} = 1$ എന്ന family യെ പ്രതിനിധാനം ചെയ്യുന്ന differential equation കാണുക.

a, b ഇവയാണ് parameter കൾ.

a, b ഇവ eliminate ചെയ്ത് second order differential equation ഉണ്ടാക്കുക.

തന്നിരിക്കുന്ന equation $\frac{x^2}{a^2} + \frac{y^2}{b^2} = 1$ (1)

Differentiate w.r. to x we get

$$\frac{2x}{a^2} + \frac{1}{b^2} 2y \frac{dy}{dx} = 0$$

i.e, $\frac{x}{a^2} + \frac{y}{b^2} \frac{dy}{dx} = 0$

i.e, $\frac{y}{b^2} \frac{dy}{dx} = \frac{-x}{a^2}$

i.e, $\frac{y}{x} \frac{dy}{dx} = \frac{-b^2}{a^2}$

differentiate w.r. to x we get

$$\frac{y}{x} \frac{d}{dx} \left(\frac{dy}{dx} \right) + \frac{dy}{dx} \cdot \frac{d}{dx} \left(\frac{y}{x} \right) = 0$$

$$\text{i.e., } \frac{y}{x} \frac{d^2y}{dx^2} + \frac{dy}{dx} \left(\frac{x \frac{dy}{dx} - y}{x^2} \right) = 0$$

Multiply by x^2 we get

$$x^2 \left(\frac{y}{x} \right) \frac{d^2y}{dx^2} + \frac{dy}{dx} \left(x \frac{dy}{dx} - y \right) = 0$$

$$xy \frac{d^2y}{dx^2} + x \left(\frac{dy}{dx} \right)^2 - y \frac{dy}{dx} = 0$$

പരിശീലനം

Formulate the differential equation.

1. $\frac{x}{a} + \frac{y}{b} = 1$
2. $y^2 = a(b^2 - x^2)$
3. $x^2 + y^2 = r^2$
4. $y^2 = 4ax$

Differential Equation ന്റെ solution

1. Variables separable form

$f(x)dx = g(y)dy$ എന്ന രൂപത്തിലുള്ള differential equation solve ചെയ്യാൻ

$$\int f(x)dx = \int g(y)dy + C \text{ എന്നെഴുതിയാൽ മതി.}$$

eg:- Find the general solution of

$$\frac{dy}{dx} = \frac{y}{x}$$

Solution

തന്നിരിക്കുന്ന equation $\frac{dy}{dx} = \frac{y}{x}$ ക്രമീകരിച്ച് എഴുതിയാൽ $xdy=ydx$

i.e., $\frac{1}{y} dy = \frac{1}{x} dx$ (ഇത് variables തരംതിരിക്കപ്പെട്ട നിലയിലാണ്)

Integrate ചെയ്താൽ solution കിട്ടും.

എങ്കിൽ

$$\int \frac{1}{y} dy = \int \frac{1}{x} dx$$

ie, $\log y = \log x + C$

ie, $\log y - \log x = C$

ie, $\log\left(\frac{y}{x}\right) = C$

ie, $\left(\frac{y}{x}\right) = e^C$

ie, $\frac{y}{x} = C_1$ Where $C_1 = e^C$

പരിശീലനം

Solve

1. $\frac{dy}{dx} = \frac{1+y^2}{1+x^2}$

2. $\frac{dy}{dx} = 2(x+y^2x)$

3. $(y+1)\frac{dy}{dx} = y(x-1)$

4. $2\sqrt{xy}\frac{dy}{dx} = 1(x, y > 0)$

5. $\frac{dy}{dx} = x^2\sqrt{y} (y > 0)$

6. $\frac{dy}{dx} = e^{x-y}$

General solution and particular solution

Arbitrary constant C ഉള്ള solution ആണ് general solution. തന്നിരിക്കുന്ന condition ഉപയോഗിച്ച് arbitrary constant eliminate ചെയ്താൽ കിട്ടുന്ന solution ആണ് particular solution.

Initial Value Problem

Variables ന്റെ initial values തന്നിട്ടുണ്ടെങ്കിൽ differential equation യെ initial value problem എന്നാണ് വിളിക്കുക. Initial value ഉപയോഗിച്ച് general solution നിലെ arbitrary constant eliminate ചെയ്ത് particular solution കാണുകയാണ് വേണ്ടത്.

ഉദാ- Find the particular solution of $\frac{dy}{dx} = -4xy^2$

given $y = 1$, when $x=0$

Solution

തന്നിരിക്കുന്ന equation $\frac{dy}{dx} = -4xy^2$

ie, $\frac{dy}{y^2} = -4xdx$ (ഇത് variables തരംതിരിക്കപ്പെട്ട നിലയിലാണ്)

Integrate ചെയ്താൽ solution കിട്ടും.

$$\int \frac{1}{y^2} dy = \int -4xdx$$

$$\text{ie, } \frac{-1}{y} = \frac{-4x^2}{2} + C$$

$$\text{ie, } \frac{1}{y} = 2x^2 - C$$

$$y = \frac{1}{2x^2 - C}$$

$x=0$ എങ്കിൽ $y=1$ എന്ന് തന്നിരിക്കുന്നു.

$$\therefore 1 = \frac{1}{2(0) - C}$$

$$\text{ie, } 1 = \frac{1}{-C} \quad C = -1$$

$$y = \frac{1}{2x^2 + 1}$$

പരിശീലനം

1. Solve $x dy = (2x^2+1)dx$, given When $x=1, y=1$
2. Solve $\frac{dy}{dx} = \frac{2x}{y^2}$, given When $x=-2, y=3$
3. Solve $x(x^2 - 1)\frac{dy}{dx} = 1$: When $x=2, y=0$.
4. Solve $\frac{dy}{dx} = y \tan x$: When $x=0, y=1$.
5. Solve $\frac{dy}{dx} = e^x \sin x$: When $x=0, y=0$.
6. Solve $xy \frac{dy}{dx} = (x+2)(y+2)$, given When $x=1, y=-1$.

UNIT TEST

Score : 20

Time : 40 minutes

I. Choose the correct answer (Score 1 each)

- The order of the differential equations of all non vertical lines in a plane is
a) 1 b) 2 c) 3 d) 0
- The differential equations of the family of all circles with centre at origin is
a) $x + y_1 = 0$ b) $x + y y_1 = 0$ c) $x - y y_1 = 0$ d) none of these
- The degree of the differential equation

$$\left(1 + \left(\frac{dy}{dx}\right)^2\right)^{\frac{5}{3}} = \frac{d^2y}{dx^2} \text{ is}$$

- a) 1 b) 3 c) 5 d) 4
- An integrating factor of the differential equation $\frac{dy}{dx} + y = \frac{1+y}{x}$ ($n > 0$) is
a) $\frac{x}{e^x}$ b) $\frac{e^x}{x}$ c) xe^x d) e^x
- The general solution of the differential equation $\frac{d^3y}{dx^3} = 0$ is
a) $ax^3 + bx^2 + cx$ b) $ax^2 + bx + c$ c) $x^3 + x^2 + c$ d) none of these

II Answer the following

- Find the area of the region bounded by the curve $y = \sqrt{3x+4}$ above the x -axis and between $x=0$ and $x=4$. (Score 2)
- Using integration, find the area of the triangle whose vertices are $(-1,6)$, $(1,2)$ and $(5,4)$ (Score 5)
- Form the differential equation of the following equation $y = e^{mx} + Be^{-mx}$ where A and B are arbitrary constants. (Score 2)
- Solve $\frac{dy}{dx} = \frac{x+y+1}{2x+2y+1}$ (Score 3)
- Solve $\frac{dy}{dx} = \frac{y}{x} = e^{-x}$ (Score 3)

Answer and hints

- (b) Equation of all non vertical lines in a plane is $y = mx + c$. m and c are parameters. Since there are two parameters the order of the differential equation is 2.
- (b) Equation of family of all angles centre at the origin is $x^2 + y^2 = r^2$

3. (b) Given differential equation is

$$\left(1 + \left(\frac{dy}{dx}\right)^2\right)^{5/3} = \frac{d^2y}{dx^2}$$

cubing we get $\left(1 + \left(\frac{dy}{dx}\right)^2\right)^5 = \left(\frac{d^2y}{dx^2}\right)^3 \therefore \text{degree} = 3$

4. (b) Given equation can be rewritten as

$$\frac{dy}{dx} + y\left(1 - \frac{1}{x}\right) = \frac{1}{x}$$

Integrating factor is $e^{\int\left(1-\frac{1}{x}\right)dx} = e^{x-\log x}$

$$= e^x \cdot e^{-\log x} = e^x \cdot x^{-1}$$

$$= \frac{e^x}{x}$$

5. (b) Given differential equation is

$$\frac{d^3y}{dx^3} = 0$$

Integrating w.r.to x we get

$$\frac{d^2y}{dx^2} = A$$

Integrating again we get

$$\frac{dy}{dx} = Ax + B$$

Integrating again we get

$$y = \frac{Ax^2}{2} + Bx + C$$

$$= \left(\frac{A}{2}\right)x^2 + Bx + C$$

$$= ax^2 + bx + C$$

6. Required area = $\int_0^4 y \, dx$

$$= \int_0^4 \sqrt{3x+4} \, dx$$

$$= \left. \frac{(3x+4)^{3/2}}{3 \times \frac{3}{2}} \right|_0^4$$

$$= \frac{2}{9} \left((3 \times 4 + 4)^{3/2} - (4)^{3/2} \right)$$

$$= \frac{2}{9} \left(16^{3/2} - 4^{3/2} \right) = \frac{2}{9} (56) = \frac{112}{9}$$

7.

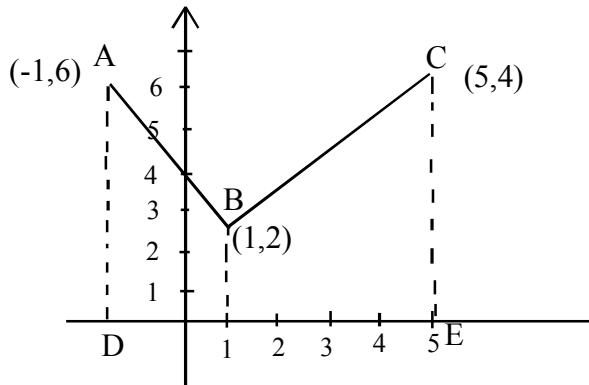

Area of the triangle = Area under AC - (Area under AB + area under BC)

Equation of AC is $y - 6 = \frac{4 - 6}{5 - (-1)}(x - (-1))$

$$y - 6 = \frac{-2}{6}(x + 1)$$

$$y = \frac{-2}{6}x + \frac{17}{3}$$

Equation of AB is $y - 6 = \frac{2 - 6}{1 - (-1)}(x - (-1))$

$$y - 6 = \frac{-4}{2}(x + 1)$$

$$y = -2x + 4$$

Equation of BC is $y - 2 = \frac{4 - 2}{5 - 1}(x - 1)$

$$y = \frac{x}{2} + \frac{3}{2}$$

Area under AC = $\int_{-1}^5 \left(\left(\frac{-1}{3}x + \frac{17}{3} \right) dx = \frac{-1}{3} \frac{x^2}{2} + \frac{17}{3}x \right)_{-1}^5$

Area under AB is $\int_{-1}^1 \left((-2x + 4) dx = \left(-2 \frac{x^2}{2} + 4x \right) \right)_{-1}^1 = 8$

Area under BC is $\int_1^5 \left(\frac{x}{2} + \frac{3}{2} \right) dx$

$$= \left(\frac{1}{2} \frac{x^2}{2} + \frac{3}{2} x \right)_1^5 = 12$$

∴ Required area = 30 - (8 + 12) = 10 square unit

8. Given differential equation is $y = Ae^{mx} + Be^{-mx}$

Differentiating we get

$$y^1 = Ae^{mx} m + B e^{-mx} (-m)$$

Differentiating again we get $y^1 = Amx.m^2 + Be^{-mx} m^2$

$$= m^2 y$$

$$\therefore y^1 - m^2 y = 0$$

9. Put $x + y = \vartheta$

$$\text{Then } 1 + \frac{dy}{dx} = \frac{d\vartheta}{dx}$$

$$\therefore \frac{dy}{dx} = \frac{d\vartheta}{dx} - 1$$

$$\therefore \frac{d\vartheta}{dx} - 1 = \frac{\vartheta + 1}{2\vartheta + 1}$$

$$\therefore \frac{d\vartheta}{dx} = \frac{\vartheta + 1}{2\vartheta + 1} + 1 = \frac{\vartheta + 1 + 2\vartheta + 1}{2\vartheta + 1}$$

$$\therefore \frac{3\vartheta + 2}{2\vartheta + 1}$$

$$\therefore \frac{2\vartheta + 1}{3\vartheta + 2} d\vartheta = dx \dots \dots \dots (1)$$

By division we get $\frac{2\vartheta + 1}{3\vartheta + 2} = \frac{2}{3} - \frac{1}{3(3\vartheta + 2)}$

∴ equation (1) becomes $\left(\frac{2}{3} - \frac{1}{3} \frac{1}{3\vartheta + 2} \right) d\vartheta = dx$

On integrating we get $\int \left(\frac{2}{3} - \frac{1}{3} \frac{1}{3\vartheta + 2} \right) d\vartheta = \int dx$

$$\therefore \frac{2}{3} \vartheta - \frac{1}{3} \frac{\log|3\vartheta + 2|}{3} = x + A$$

$$\therefore 6\vartheta - \log|3\vartheta + 2| = 9x + C$$

$$\therefore 6(x + y) - \log|3(x + y) + 2| = 9x + C$$

$$6y - 3x - \log|3(x + y) + 2| = C$$

10. Given equation of the form

$$\frac{dy}{dx} + P(x)y = Q(x)$$

Where $P(x) = \frac{1}{x}$ $Q(x) = e^{-x}$

Integrating factor is $e^{\int \frac{1}{x} dx} = e^{\log x} = x$

Multiply the given equation by integrating factor we get

$$\frac{d}{dx}(yx) = e^{-x} \cdot x$$

$$xy = \int e^{-x} x dx$$

$$= x \int e^{-x} dx - \int \left(\frac{d}{dx}(x) \int e^{-x} dx \right) dx$$

$$= x \frac{e^{-x}}{-1} - \int (e^{-x} dx) dx$$

$$= -xe^{-x} - \int \frac{e^{-x}}{-1} dx = -x e^{-x} + \int e^{-x} dx$$

ie, $xy = -x e^{-x} + \frac{e^{-x}}{-1} + C$

ie, $xy + xe^{-x} + e^{-x} = C$

12. VECTOR ALGEBRA

Vectors

Quantities having both magnitude and direction.

Eg: Velocity, acceleration force, weight, momentum etc.

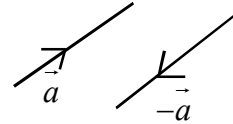

Types of Vector

Zero vector - vector having zero magnitude.

Unit vector - vector having magnitude 1.

$\vec{i}, \vec{j}, \vec{k}$ are unit vectors along OX, OY, OZ axis,

Co-initial vectors - Two or more vectors having same initial point.

\vec{a}, \vec{b} & \vec{c} are co-initial vectors.

Collinear vectors - The vectors having same or parallel line of action.

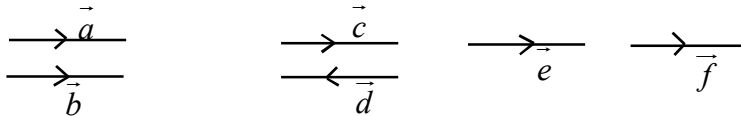
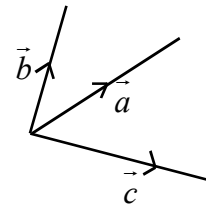

here $\vec{a}, \vec{b}, \vec{c}, \vec{d}, \vec{e}, \vec{f}$ are collinear vectors.

Equal vectors - two vectors having same magnitude and direction are called equal vectors.

Negative of a vector - If \vec{a} is a vector then $-\vec{a}$ is called negative of vector \vec{a} . Which has same magnitude and opposite direction as that of \vec{a} .

Components of vectors-

Consider the rectangular co-ordinate system in 3 dimensional geometry.

O is the origin and OX, OY, OZ are +ve X axis, +ve Y axis and +ve z axis.

Let $\vec{i}, \vec{j}, \vec{k}$ be the unit vectors along OX OY and OZ axis respectively. Any vector in space can be expressed in terms of these unit vectors

$$\text{as } \vec{a} = a_1\vec{i} + a_2\vec{j} + a_3\vec{k}$$

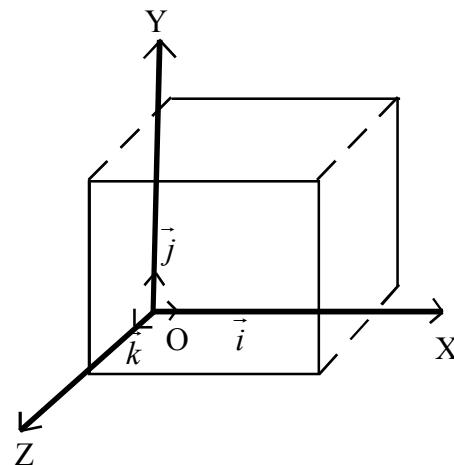

If P(x, y, z) is a point in the space then \vec{OP} is called position vector of P and

$$\vec{OP} = x\vec{i} + y\vec{j} + z\vec{k}$$

Magnitude (modulus) of a vector $a_1\vec{i} + a_2\vec{j} + a_3\vec{k}$ is $\sqrt{a^2 + b^2 + c^2}$.

Addition : Let $\vec{a} = a_1\vec{i} + a_2\vec{j} + a_3\vec{k}$

$$\vec{b} = b_1\vec{i} + b_2\vec{j} + b_3\vec{k}$$

Then $\vec{a} + \vec{b} = (a_1 + b_1)\vec{i} + (a_2 + b_2)\vec{j} + (a_3 + b_3)\vec{k}$

ie, if $\vec{a} = 3\vec{i} - 2\vec{j} + 4\vec{k}$ &

$$\vec{b} = 2\vec{i} + \vec{j} + 5\vec{k}$$

Then $\vec{a} + \vec{b} = 5\vec{i} - \vec{j} + 9\vec{k}$

Vector joining two points

If P(x₁, y₁, z₁) Q(x₂, y₂, z₃) are any two points then,

$$\vec{PQ} = (x_2 - x_1)\vec{i} + (y_2 - y_1)\vec{j} + (z_2 - z_1)\vec{k}$$

Section formula : Position vector of the point P which divided the line segment joining A(\vec{a}) & B(\vec{b}) in

the ratio m:n is given by $\vec{r} = \frac{m\vec{b} + n\vec{a}}{m + n}$

Qn: Find the magnitude of the vector $\vec{a} = 2\vec{i} - 7\vec{j} - 3\vec{k}$

Ans: $|\vec{a}| = \sqrt{2^2 + 7^2 + 3^2} = \sqrt{4 + 49 + 9} = \sqrt{62}$

• Unit vector along a vector \vec{a} is given by $\frac{\vec{a}}{|\vec{a}|}$

Qn: Find the unit vector along $\vec{a} = 3\vec{i} + 2\vec{j} + 4\vec{k}$

Ans: $\vec{a} = 3\vec{i} + 2\vec{j} + 4\vec{k}$

$$|\vec{a}| = \sqrt{3^2 + 2^2 + 4^2} = \sqrt{9 + 4 + 16} = \sqrt{29}$$

$$\therefore \text{unit vector along } \vec{a} = \frac{3\vec{i} + 2\vec{j} + 4\vec{k}}{\sqrt{29}}$$

Qn: Find the unit vector in the direction of $\vec{a} + \vec{b}$ where $\vec{a} = 2\vec{i} - \vec{j} + 2\vec{k}$ and $\vec{b} = -\vec{i} - \vec{j} - \vec{k}$

Here $\vec{a} + \vec{b} = \vec{i} + \vec{k}$

$$|\vec{a} + \vec{b}| = \sqrt{1^2 + 1^2} = \sqrt{2}$$

$$\text{hence unit vector in the direction of } \vec{a} + \vec{b} = \frac{\vec{a} + \vec{b}}{|\vec{a} + \vec{b}|} = \frac{\vec{i} + \vec{k}}{\sqrt{2}}$$

Product of two Vectors

1) Scalar (dot) Product of two vectors

If \vec{a} and \vec{b} are two vectors, then $\vec{a} \cdot \vec{b} = |\vec{a}| \cdot |\vec{b}| \cdot \cos \theta$

Where θ is the angle between \vec{a} & \vec{b}

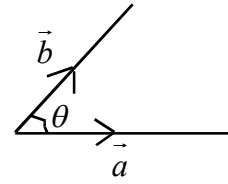

Results 1) $\vec{a} \cdot \vec{b}$ is a real number

$$2) \vec{a} \cdot \vec{b} = \vec{b} \cdot \vec{a}$$

$$3) \vec{a} \cdot \vec{b} = 0 \Leftrightarrow \vec{a} \perp \vec{b}$$

$$4) \vec{a} \cdot \vec{a} = |\vec{a}|^2$$

$$5) \vec{i} \cdot \vec{i} = \vec{j} \cdot \vec{j} = \vec{k} \cdot \vec{k} = 1 \quad \& \quad \vec{i} \cdot \vec{j} = \vec{j} \cdot \vec{k} = \vec{k} \cdot \vec{i} = 0$$

6) Angle between two vectors \vec{a} & \vec{b}

$$\text{is } \cos \theta = \frac{\vec{a} \cdot \vec{b}}{|\vec{a}| \cdot |\vec{b}|}$$

7) Projection of \vec{a} in the direction of \vec{b} is $\frac{\vec{a} \cdot \vec{b}}{|\vec{b}|}$

8) If $\vec{a} = a_1\vec{i} + a_2\vec{j} + a_3\vec{k}$ & $\vec{b} = b_1\vec{i} + b_2\vec{j} + b_3\vec{k}$ then

$$\vec{a} \cdot \vec{b} = a_1b_1 + a_2b_2 + a_3b_3$$

Ex. 1 Find $\vec{a} \cdot \vec{b}$ where $\vec{a} = \vec{i} - 2\vec{j} + 3\vec{k}$ and $\vec{b} = 3\vec{i} - 2\vec{j} + \vec{k}$

Sol. $\vec{a} \cdot \vec{b} = (1 \times 3) + (-2 \times -2) + (3 \times 1) = 3 + 4 + 3 = 10$

Ex. 2 Show that the vectors $2\vec{i} - \vec{j} + \vec{k}$, $\vec{i} - 3\vec{j} - 5\vec{k}$ and $3\vec{i} - 4\vec{j} - 4\vec{k}$ form the vertices of a right angled triangle.

Sol: Let the vertices be $A(2\vec{i} - \vec{j} + \vec{k})$, $B(\vec{i} - 3\vec{j} - 5\vec{k})$ $C(3\vec{i} - 4\vec{j} - 4\vec{k})$

$$\text{Then } \overline{AB} = \overline{OB} - \overline{OA} = (1 - 2)\vec{i} + (-3 + 1)\vec{j} + (-5 - 1)\vec{k} = -\vec{i} - 2\vec{j} - 6\vec{k}$$

$$\overline{BC} = (3 - 1)\vec{i} + (-4 + 3)\vec{j} + (-4 + 5)\vec{k} = 2\vec{i} - \vec{j} + \vec{k}$$

$$\overline{AC} = (3 - 2)\vec{i} + (-4 + 1)\vec{j} + (-4 - 1)\vec{k} = \vec{i} - 3\vec{j} - 5\vec{k}$$

$$\text{Now } \overline{BC} \cdot \overline{AC} = (2 \times 1) + (-1 \times -3) + (1 \times -5) = 2 + 3 - 5 = 0$$

ie, $\overline{BC} \perp \overline{AC} \therefore \Delta ABC$ is right angled Δ

Ex. 3 Find the projection of the vector $\vec{i} + 3\vec{j} + 7\vec{k}$ on the vector $7\vec{i} - \vec{j} + 8\vec{k}$

Sol. Let $\vec{a} = \vec{i} + 3\vec{j} + 7\vec{k}$ $\vec{b} = 7\vec{i} - \vec{j} + 8\vec{k}$

$$\text{Projection of } \vec{a} \text{ on } \vec{b} = \frac{\vec{a} \cdot \vec{b}}{|\vec{b}|} = \frac{(1 \times 7) + (3 \times -1) + (7 \times 8)}{\sqrt{7^2 + (-1)^2 + 8^2}} = \frac{7 - 3 + 56}{\sqrt{49 + 1 + 64}} = \frac{60}{\sqrt{114}}$$

Ex. 4 For and two vectors \vec{a} & \vec{b} . $|\vec{a} + \vec{b}| \leq |\vec{a}| + |\vec{b}|$ (triangle inequality)

$$|\vec{a} + \vec{b}|^2 = (\vec{a} + \vec{b}) \cdot (\vec{a} + \vec{b})$$

$$\begin{aligned}
&= \vec{a} \cdot \vec{a} + \vec{a} \cdot \vec{b} + \vec{b} \cdot \vec{a} + \vec{b} \cdot \vec{b} \\
&= |\vec{a}|^2 + 2(\vec{a} \cdot \vec{b}) + |\vec{b}|^2 \\
&\leq |\vec{a}|^2 + 2|\vec{a}||\vec{b}| + |\vec{b}|^2 \\
&= (|\vec{a}| + |\vec{b}|)^2 \\
|\vec{a} + \vec{b}| &\leq |\vec{a}| + |\vec{b}|
\end{aligned}$$

Cauchy Schwartz inequality

$$|\vec{a} \cdot \vec{b}| \leq |\vec{a}| \cdot |\vec{b}|$$

Proof

$$\frac{\vec{a} \cdot \vec{b}}{|\vec{a}||\vec{b}|} = |\cos\theta| \leq 1$$

$$|\vec{a} \cdot \vec{b}| \leq |\vec{a}||\vec{b}|, \quad |\vec{a}| \neq 0, \quad |\vec{b}| \neq 0$$

Vector (or Cross) Product of two vectors

The Vector product of two vectors \vec{a} & \vec{b} denoted by $\vec{a} \times \vec{b}$ defined as $\vec{a} \times \vec{b} = |\vec{a}||\vec{b}| \sin\theta \vec{n}$

Where θ is the angle between \vec{a} & \vec{b} and \vec{n} is a unit vector perpendicular to \vec{a} and \vec{b} .

So that $\vec{a}, \vec{b}, \vec{n}$ form a right handed system.

Results:

- 1) $\vec{a} \times \vec{b}$ is a vector perpendicular to the plane of \vec{a} & \vec{b}
- 2) $\vec{i} \times \vec{j} = \vec{k}, \vec{j} \times \vec{k} = \vec{i} \quad \& \quad \vec{k} \times \vec{i} = \vec{j}$
 $\vec{j} \times \vec{i} = -\vec{k}, \vec{k} \times \vec{j} = -\vec{i} \quad \& \quad \vec{i} \times \vec{k} = -\vec{j}$
- 3) Unit vector perpendicular to \vec{a} & \vec{b} is $\frac{\vec{a} \times \vec{b}}{|\vec{a} \times \vec{b}|}$
- 4) If \vec{a} and \vec{b} represents adjacent sides of a parallelogram $|\vec{a} \times \vec{b}|$ gives its area.
- 5) If \vec{a} and \vec{b} represents sides of a triangle, its area $\frac{1}{2}|\vec{a} \times \vec{b}|$
- 6) If $\vec{a} = a_1\vec{i} + a_2\vec{j} + a_3\vec{k}$ and $\vec{b} = b_1\vec{i} + b_2\vec{j} + b_3\vec{k}$

$$\vec{a} \times \vec{b} = \begin{vmatrix} \vec{i} & \vec{j} & \vec{k} \\ a_1 & a_2 & a_3 \\ b_1 & b_2 & b_3 \end{vmatrix}$$

Ex.1 Find $\vec{a} \times \vec{b}$ if $\vec{a} = 2\vec{i} + \vec{j} + 3\vec{k}$ and $\vec{b} = 3\vec{i} + 5\vec{j} - 2\vec{k}$

Sol:
$$\vec{a} \times \vec{b} = \begin{vmatrix} \vec{i} & \vec{j} & \vec{k} \\ 2 & 1 & 3 \\ 3 & 5 & -2 \end{vmatrix} = \vec{i}(-2-5) - \vec{j}(-4-9) + \vec{k}(10-3)$$

$$= -7\vec{i} + 13\vec{j} - 7\vec{k}$$

Ex.2 Find a unit vector perpendicular to each of the vectors $\vec{a} + \vec{b}$ and $\vec{a} - \vec{b}$ where

$$\vec{a} = \vec{i} + \vec{j} + \vec{k}, \quad \vec{b} = \vec{i} + 2\vec{j} + 3\vec{k}$$

Sol: $\vec{a} + \vec{b} = 2\vec{i} + 3\vec{j} + 4\vec{k}$ and $\vec{a} - \vec{b} = -\vec{j} - 2\vec{k}$

u.v. perpendicular to $\vec{a} + \vec{b}$ and $\vec{a} - \vec{b}$ is $\frac{(\vec{a} + \vec{b}) \times (\vec{a} - \vec{b})}{|(\vec{a} + \vec{b}) \times (\vec{a} - \vec{b})|}$

$$\vec{a} + \vec{b} \times \vec{a} - \vec{b} = \begin{vmatrix} \vec{i} & \vec{j} & \vec{k} \\ 2 & 3 & 4 \\ 0 & -1 & -2 \end{vmatrix} = -2\vec{i} + 4\vec{j} - 2\vec{k}$$

$$\text{Req. u.v.} = \frac{-2\vec{i} + 4\vec{j} - 2\vec{k}}{\sqrt{4 + 16 + 4}} = \frac{2(-\vec{i} + 2\vec{j} - \vec{k})}{2\sqrt{6}} = \frac{-\vec{i} + 2\vec{j} - \vec{k}}{\sqrt{6}}$$

Ex. 3 Find the area of the parallelogram whose adjacent sides are $\vec{a} = \vec{i} - \vec{j} + 3\vec{k}$ and $2\vec{i} - 7\vec{j} + \vec{k}$

Sol. Area of a parallelogram is $|\vec{a} \times \vec{b}|$

$$|\vec{a} \times \vec{b}| = \begin{vmatrix} \vec{i} & \vec{j} & \vec{k} \\ 1 & -1 & 3 \\ 2 & -7 & 1 \end{vmatrix} = \vec{i}(-1 + 21) - \vec{j}(1 - 6) + \vec{k}(-7 + 2)$$

$$= \vec{i}(20) + 5\vec{j} - 5\vec{k}$$

$$\text{Req. Area} = \sqrt{400 + 25 + 25} = \sqrt{500} = 10\sqrt{5} \text{ sq. unit}$$

- * If \vec{a} and \vec{b} are two collinear vectors $\vec{a} \times \vec{b} = 0$
- * If A B C are collinear points then, $\overline{AB} \times \overline{BC} = 0$
- * If $\vec{a}, \vec{b}, \vec{c}$ are three coplanar vectors then, $(\vec{a} \times \vec{b}) \cdot \vec{c} = 0$ (Since $\vec{a} \times \vec{b}$ & \vec{c} are $\perp r$)

UNIT TEST

- 1) If $|\vec{a} + \vec{b}| = |\vec{a} - \vec{b}|$ then angle between \vec{a} & $\vec{b} = ?$
 $(0, \pi/4, \pi/3, \pi/2)$ (1)
- 2) Given ABC are the points (2, 1, -1), (3, 2, -1) & (3, 1, 0) find the angle between the vectors \overline{AB} & \overline{AC} (3)
- 3) Find the value of λ so that the following vectors are \perp (2)
 $\vec{a} = 2\vec{i} + 3\vec{j} + 4\vec{k}$ and $3 + 2\vec{j} - \lambda\vec{k}$
- 4) Find a vector orthogonal to both $\vec{j} + \vec{j} + 5\vec{k}$ and $2\vec{i} - \vec{k}$ (2)
- 5) If D, E, F are midpoints of sides of a triangle ABC. Prove that area of triangle DEF = $\frac{1}{4}$ area of triangle ABC. (3)
(Hints : Position vector of midpoint of AB is $\frac{\vec{a} + \vec{b}}{2}$)
- 6) If θ is the angle between two vectors \vec{a} & \vec{b} then $\frac{\vec{a} \times \vec{b}}{|\vec{a}||\vec{b}|}$ is $(\cot\theta, -\cot\theta, \tan\theta, -\tan\theta)$ (1)
- 7) Determine area of the parallelogram whose adjacent sides are $\vec{a} + \vec{b}$ and $\vec{a} - \vec{b}$. (3)
Where $\vec{a} = \vec{i} - \vec{j} - \vec{k}$ & $\vec{b} = 3\vec{c} + 4\vec{j} - 5\vec{k}$

13. THREE DIMENSIONAL GEOMETRY

Introduction

In this chapter we use vector algebra to 3 Dimensional Geometry. Here we shall study direction cosines and direction ratios of line, equations of lines and planes in space, angle between two lines, two planes and a line and plane. Shortest distance between two planes, etc.

Direction Cosines and direction ratios of a line

If a line makes angles α, β, γ with X axis Y axis and Z axis then $\text{Cos}\alpha, \text{Cos}\beta, \text{Cos}\gamma$ are called direction cosines usually denoted by l, m, n . Any three numbers a, b, c proportional to l, m, n are called direction ratios.

$$\text{ie, } \frac{l}{a} = \frac{m}{b} = \frac{n}{c} = k$$

For a point P(x, y, z) in space x, y, z can be taken as direction ratios of \overline{OP} .

Direction ratios of the line joining (x_1, y_1, z_1) & (x_2, y_2, z_2) are given by $x_2-x_1, y_2-y_1, z_2-z_1$

Relation between direction Cosines and direction ratios.

$$l = \frac{a}{\sqrt{a^2 + b^2 + c^2}}, \quad m = \frac{b}{\sqrt{a^2 + b^2 + c^2}}, \quad n = \frac{c}{\sqrt{a^2 + b^2 + c^2}}$$

If l, m, n are direction cosines of a line then $l^2 + m^2 + n^2 = 1$

Qn: Find the direction cosines of line which make equal angles with axis.

Ans: Here $\alpha = \beta = \gamma$ ie, $\text{Cos}\alpha = \text{Cos}\beta = \text{Cos}\gamma$

$$\text{ie, } l = m = n = \text{Cos}\alpha$$

$$\text{Now } l^2 + m^2 + n^2 = 1 \Rightarrow$$

$$\Rightarrow \text{Cos}^2\alpha + \text{Cos}^2\alpha + \text{Cos}^2\alpha = 1$$

$$\Rightarrow 3\text{Cos}^2\alpha = 1 \Rightarrow \text{Cos}^2\alpha = \frac{1}{3} \Rightarrow \text{Cos}\alpha = \frac{1}{\sqrt{3}}$$

$$\text{ie, direction cosines are } \left(\frac{1}{\sqrt{3}}, \frac{1}{\sqrt{3}}, \frac{1}{\sqrt{3}} \right)$$

Qn: Show that the points (2, 3, 4) (-1, -2, 1) & (5, 8, 7) are collinear

Ans: Let the points be A (2, 3, 4) B(-1,-2, 1) & C (5, 8, 7)

$$\text{Now } \overline{AB} = \overline{OB} - \overline{OA} = (-1 -2)\mathbf{i} + (-2 -3)\mathbf{j} + (1-4)\mathbf{k}$$

$$\text{ie, } -3\mathbf{i} -5\mathbf{j} -3\mathbf{k}$$

Similarly find \overline{AC} ?

$$\overline{AC} = 3\mathbf{i} + 5\mathbf{j} + 3\mathbf{k}$$

d.r.s of AB -3, -5, -3

d.r.s of AC 3, 5, 3

here $\frac{-3}{3} = \frac{-5}{5} = \frac{-3}{3}$ ie d.r.s are proportional hence lines are parallel with a common point
ie, A B C are collinear.

Qn: Find the direction cosines of X axis, Y axis and Z axis.

Ans: Direction Cosines of X axis is 1, 0, 0

Y axis 0, 1, 0

Z axis 0, 0, 1

Equation of line in space

Equation of a line passing through a given point A having position vector \vec{a} and parallel to the given vector \vec{b} is given by $\vec{r} = \vec{a} + \lambda\vec{b}$ (Vector equation)

$$\vec{r} = x\vec{i} + y\vec{j} + z\vec{k}, \quad \vec{a} = x_1\vec{i} + y_1\vec{j} + z_1\vec{k}, \quad \vec{b} = a\vec{i} + b\vec{j} + c\vec{k}$$

$$\text{Then } \vec{r} = \vec{a} + \lambda\vec{b} \Rightarrow \frac{x-x_1}{a} = \frac{y-y_1}{b} = \frac{z-z_1}{c} \text{ (Cartesian equation)}$$

Qn: Find the vector equation of a line through the point (5, 2, -4) and parallel to the vector $3\vec{i} + 2\vec{j} - 8\vec{k}$

Ans: Here line is $\vec{r} = \vec{a} + \lambda\vec{b}$, $\vec{a} = 5\vec{c} + 2\vec{j} - 4\vec{k}$, $\vec{b} = 3\vec{c} + 2\vec{j} - 8\vec{k}$

$$\text{hence required line is } \vec{r} = 5\vec{c} + 2\vec{j} - 4\vec{k} + \lambda(3\vec{i} + 2\vec{j} - 8\vec{k})$$

Equation of a line passing through two points A(\vec{a}) & B(\vec{b})

$$\vec{r} = \vec{a} + \lambda(\vec{b} - \vec{a}) \text{ Where } \vec{a} \text{ \& } \vec{b} \text{ are p.v. of this points.}$$

$$\text{Its cartesian form is } \frac{x-x_1}{x_2-x_1} = \frac{y-y_1}{y_2-y_1} = \frac{z-z_1}{z_2-z_1}$$

Qn: Find the vector eqn. and cartesian equation of the line passing through the points (-1,0,2) and

(3,4,6)

$$\text{Vector equation is } \vec{r} = \vec{a} + \lambda(\vec{b} - \vec{a})$$

$$\text{ie, } \vec{r} = (-\vec{i} + 0\vec{j} + 2\vec{k}) + \lambda(3\vec{i} + 4\vec{j} + 6\vec{k} - (-\vec{i} + 2\vec{k}))$$

$$\text{ie, } \vec{r} = -\vec{i} + 2\vec{k} + \lambda(3\vec{i} + 4\vec{j} + 6\vec{k} - (-\vec{i} + 2\vec{k}))$$

$$\text{Its cartesian form is } \frac{x+1}{4} = \frac{y-0}{4} = \frac{z-2}{4}$$

Angle between two lines $\vec{r} = \vec{a}_1 + \lambda\vec{b}_1$ & $\vec{r} = \vec{a}_2 + \mu\vec{b}_2$

Angle between two line is the angle between their parallel vectors ie, \vec{b}_1 & \vec{b}_2

$$\text{ie, } \cos\theta = \frac{\vec{b}_1 \cdot \vec{b}_2}{|\vec{b}_1| |\vec{b}_2|}$$

$$\text{If } \vec{b}_1 = a_1\vec{i} + b_1\vec{j} + c_1\vec{k}$$

$$\vec{b}_2 = a_2\vec{i} + b_2\vec{j} + c_2\vec{k}$$

$$\text{then } \cos\theta = \frac{a_1a_2 + b_1b_2 + c_1c_2}{\sqrt{a_1^2 + b_1^2 + c_1^2} \sqrt{a_2^2 + b_2^2 + c_2^2}}$$

Qn: Find the angle between the pair of lines.

$$\vec{r} = 3\vec{i} + 2\vec{j} + 4\vec{k} + \lambda(\vec{i} + 2\vec{j} + 2\vec{k})$$

$$\vec{r} = 5\vec{i} + 2\vec{j} + \mu(3\vec{i} + 2\vec{j} + 6\vec{k})$$

Ans: Here $\vec{b}_1 = \vec{i} + 2\vec{j} + 3\vec{k}$ and $\vec{b}_2 = 3\vec{i} + 2\vec{j} + 6\vec{k}$

$$\text{then angle between the lines } \cos\theta = \frac{\vec{b}_1 \cdot \vec{b}_2}{|\vec{b}_1| |\vec{b}_2|}$$

$$\vec{b}_1 \cdot \vec{b}_2 = (1 \times 3) + (2 \times 2) + (3 \times 6) = 3 + 4 + 18 = 25$$

$$|\vec{b}_1| = \sqrt{1 + 4 + 9} = \sqrt{14}; |\vec{b}_2| = \sqrt{3^2 + 2^2 + 6^2} = \sqrt{49} = 7$$

$$\cos\theta = \frac{25}{\sqrt{14} \times 7}$$

Shortest Distance

Shortest distance between two lines $\vec{r} = \vec{a}_1 + \lambda\vec{b}_1$ & $\vec{r} = \vec{a}_2 + \mu\vec{b}_2$ is given.

$$d = \left| \left(\vec{a}_2 - \vec{a}_1 \right) \cdot \frac{(\vec{b}_1 \times \vec{b}_2)}{|\vec{b}_1 \times \vec{b}_2|} \right|$$

Qn: Find the shortest distance between the lines

$$\vec{r} = (\vec{i} + 2\vec{j} + \vec{k}) + \lambda(\vec{i} - \vec{j} + \vec{k}) \text{ and}$$

$$\vec{r} = (2\vec{i} - \vec{j} - \vec{k}) + \mu(2\vec{i} + \vec{j} + \vec{k})$$

Ans: Here

$$\vec{a}_1 = \vec{i} + 2\vec{j} + \vec{k}$$

$$\vec{a}_2 = 2\vec{i} - \vec{j} - \vec{k}$$

$$\vec{b}_1 = \vec{i} - \vec{j} + \vec{k}$$

$$\vec{b}_2 = 2\vec{i} + \vec{j} + \vec{k}$$

$$\vec{a}_2 - \vec{a}_1 = \vec{i} - 3\vec{j} - 2\vec{k}$$

$$\vec{b}_1 \times \vec{b}_2 = \begin{vmatrix} \vec{i} & \vec{j} & \vec{k} \\ 1 & -1 & 1 \\ 2 & 1 & 1 \end{vmatrix} = \vec{i}(-2) - \vec{j}(-1) + \vec{k}(3) = -2\vec{i} + \vec{j} + 3\vec{k}$$

$$|\vec{b}_1 \times \vec{b}_2| = \sqrt{4+1+9} = \sqrt{14}$$

$$d = \frac{|(\vec{b}_1 \times \vec{b}_2) \cdot (\vec{a}_2 - \vec{a}_1)|}{|\vec{b}_1 \times \vec{b}_2|} = \frac{|(-2\vec{i} + \vec{j} + 3\vec{k}) \cdot (\vec{i} - 3\vec{j} - 2\vec{k})|}{\sqrt{14}}$$

$$= \frac{|-2-3-6|}{\sqrt{14}} = \frac{11}{\sqrt{14}}$$

Distance between two parallel lines $\vec{r} = \vec{a}_1 + \lambda\vec{b}$ & $\vec{r} = \vec{a}_2 + \mu\vec{b}$ is given by $d = \frac{|\vec{b} \times (\vec{a}_2 - \vec{a}_1)|}{|\vec{b}|}$

Plane: General form of a plane is

$$ax+by+cz+d=0$$

or $\vec{r} \cdot \vec{m} + d = 0$ where \vec{m} is the perpendicular vector to the plane. (Normal vector to the plane)

Equation of a plane perpendicular to a given vector and passing through a given point.

A be a point in the plane

and \vec{m} perpendicular to the plane P be an arbitrary point in the plane then $\overrightarrow{AP} \cdot \vec{m} = 0$ ie,

$$(\vec{r} - \vec{a}) \cdot \vec{m} = 0$$

Which is vector equation and cartesian form is $A(x-x_1)+B(y-y_1)+C(z-z_1)=0$

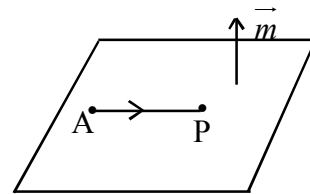

Qn: Find the vector and cartesian equation of the plane passes through the point (5,2,-4) and \perp to the line with direction ratios (2, 3, -1).

Ans: Here $\vec{a} = 5\vec{i} + 2\vec{j} - 4\vec{k}$ and $\vec{m} = 2\vec{i} + 3\vec{j} - \vec{k}$

\therefore Vector Eqyatuib of the plane is $(\vec{r} - (5\vec{i} + 2\vec{j} - 4\vec{k})) \cdot (2\vec{i} + 3\vec{j} - \vec{k}) = 0$

Cartesion equation is,

$$2(x-5) + 3(y-2) - (z+4) = 0$$

$$2x + 3y - z - 10 - 6 - 4 = 0$$

$$\text{ie, } 2x + 3y - z - 20 = 0$$

Qn: Find the equation of the plane passes through (1,4,6) and normal vector to the plane is $\vec{i} + \vec{j} - \vec{k}$

Ans: Vector equation to the plane is $[\vec{r} - (\vec{i} + 4\vec{j} + 6\vec{k})] \cdot (\vec{i} + \vec{j} - \vec{k}) = 0$

Cartesian equation of the plane is $x - 2y + z + 1 = 0$

Equation of a plane passing through 3 non collinear points with position vectors $\vec{a}, \vec{b}, \vec{c}$ is given by

$$\text{ie, } (\vec{r} - \vec{a}) \cdot (\vec{b} - \vec{a}) \times (\vec{c} - \vec{a}) = 0$$

If,

$$\vec{a} = x_1\vec{i} + y_1\vec{j} + z_1\vec{k}$$

$$\vec{b} = x_2\vec{i} + y_2\vec{j} + z_2\vec{k}$$

$$\vec{c} = x_3\vec{i} + y_3\vec{j} + z_3\vec{k}$$

Then Cartesian form of the plane is

$$\begin{vmatrix} x - x_1 & y - y_1 & z - z_1 \\ x_2 - x_1 & y_2 - y_1 & z_2 - z_1 \\ x_3 - x_1 & y_3 - y_1 & z_3 - z_1 \end{vmatrix} = 0$$

Qn: Find the vector equation and cartesian equation of the plane passing through A(2, 5, -3), B(-2,-3,5) & C(5, 3, -3)

$$(\vec{r} - \vec{a}) \cdot [(\vec{b} - \vec{a}) \times (\vec{c} - \vec{a})] = 0$$

Where $\vec{a} = 2\vec{i} + 5\vec{j} - 3\vec{k}$

$$\vec{b} = -2\vec{i} + 3\vec{j} - 5\vec{k}$$

$$\vec{c} = 5\vec{i} + 3\vec{j} - 3\vec{k}$$

Cartesian eqn is $\begin{vmatrix} x-2 & y-5 & z+3 \\ 0 & -8 & 8 \\ 3 & -2 & 0 \end{vmatrix} = 0$

ie, $(x-2)(16) - (y-5)(-24) + (z+3)(24) = 0$

Intercept form

Intercept form of a plane with intercepts are α, β, γ is given by $\frac{x}{\alpha} + \frac{y}{\beta} + \frac{z}{\gamma} = 1$

If the intercepts of a plane are 2, 3, 4 its equation is $\frac{x}{2} + \frac{y}{3} + \frac{z}{4} = 1$

Equation of the plane passing through the intersection of two planes $a_1x + b_1y + c_1z + d_1 = 0$ & $a_2x + b_2y + c_2z + d_2 = 0$ is given by I plane + k (II plane) = 0.

ie, $a_1x + b_1y + c_1z + d_1 + k(a_2x + b_2y + c_2z + d_2) = 0$

Qn: Find the vector equation of the plane passing through the intersection of the planes

$\vec{r} \cdot (\vec{i} + \vec{j} + \vec{k}) = 6$ and $\vec{r} \cdot (2\vec{i} + 3\vec{j} + 4\vec{k}) = -5$ and the point (1, 1, 1)

I plane is $x + y + z - 6 = 0$

II plane is $2x + 3y + 4z + 5 = 0$

Eqn of the required family of planes is

ie, $(x + y + z - 6) + k(2x + 3y + 4z + 5) = 0$ (1)

(1) pass through (1, 1, 1)

$\Rightarrow 1 + 1 + 1 - 6 + k(2 + 3 + 4 + 5) = 0$

$$-3 + k(14) = 0 \quad \text{ie, } 14k = 3, k = \frac{3}{14}$$

hence required plane is

$$x + y + z - 6 + \frac{3}{14}(2x + 3y + 4z + 5) = 0$$

$$\text{ie, } 14x + 14y + 14z - 84 + 6x + 9y + 12z + 15 = 0$$

$$\text{ie, } 20x + 23y + 26z - 69 = 0$$

$$\text{its vector form is } \vec{r} \cdot (20\vec{i} + 23\vec{j} + 26\vec{k}) = 69$$

- Coplanarity of two lines

The lines $\vec{r} = \vec{a}_1 + \lambda\vec{b}_1$ and $\vec{r} = \vec{a}_2 + \lambda\vec{b}_2$ coplanar iff $(\vec{a}_2 - \vec{a}_1) \cdot (\vec{b}_1 \times \vec{b}_2) = 0$

Angle between two planes

Angle between two planes is equal to angle between their normals. Consider the planes.

$$(\vec{r} \cdot \vec{m}_1) + d_1 = 0 \quad \&$$

$$(\vec{r} \cdot \vec{m}_2) + d_2 = 0$$

angle between the planes is equal to the angle between their normal vectors ie, \vec{m}_1 and \vec{m}_2

$$\cos\theta = \frac{\vec{m}_1 \cdot \vec{m}_2}{|\vec{m}_1| |\vec{m}_2|}$$

Distance of a point from the plane:

Let $ax + by + cz + d = 0$ be the plane and (x_1, y_1, z_1) be the point. Then distance between them,

$$d = \left| \frac{ax_1 + by_1 + cz_1 + d}{\sqrt{a^2 + b^2 + c^2}} \right|$$

Ex: Find the distance of the point $(2, 5, -3)$ from the plane $\vec{r} \cdot (6\vec{i} - 3\vec{j} + 2\vec{k}) = 4$

Sol: Plane is $6x - 3y + 2z - 4 = 0$ & point is $(2, 5, -3)$

$$\text{distance } d = \left| \frac{6 \times 2 - 3 \times 5 + 2 \times (-3) - 4}{\sqrt{6^2 + (-3)^2 + 2^2}} \right| = \left| \frac{12 - 15 - 6 - 4}{\sqrt{49}} \right| = \frac{13}{7}$$

Angle between line and a plane

Let the line be $\vec{r} = \vec{a} + \lambda\vec{b}$ & plane be $\vec{r} \cdot \vec{m} + d = 0$

$$\cos(90 - \theta) = \frac{\vec{m} \cdot \vec{b}}{|\vec{m}| |\vec{b}|} \text{ ie, } \sin\theta = \left| \frac{\vec{m} \cdot \vec{b}}{|\vec{m}| |\vec{b}|} \right|$$

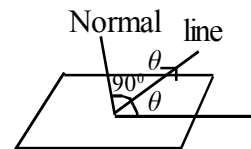

UNIT TEST

- 1) Find the vector equation of a plane which is at a distance 7 units from the origin. (2)
- 2) What is equation of a plane through the intersection of the planes $3x - y + 2z - 4 = 0$ and $x + y + z - 2 = 0$ and the point (2, 2, 1) (3)
- 3) The lines $\frac{x-1}{2} = \frac{y-1}{2} = \frac{z-3}{0}$ and $\frac{x-2}{0} = \frac{y-3}{0} = \frac{z-4}{1}$ are (1)
(parallel, coincident, skew, perpendicular)
- 4) Find the angle between the lines $\vec{r} = 3\vec{i} + 2\vec{j} - 4\vec{k} + \lambda(\vec{i} + 2\vec{j} + 2\vec{k})$,
 $\vec{r} = 5\vec{j} - 2\vec{k} + \mu(3\vec{i} + 2\vec{j} + 6\vec{k})$ (2)
- 5) Find the equation of the line through the point (1, 2, 4) and the line $\vec{r} = 2\vec{i} - \vec{j} + 4\vec{k} + \lambda(\vec{i} + \vec{j} + \vec{k})$ (3)
- 6) What are skew lines? Find the distance between the skew lines $\frac{x}{1} = \frac{y-2}{2} = \frac{z-1}{1}$ & $\frac{x-3}{3} = \frac{y-1}{2} = \frac{z-2}{1}$ (4)

14. LINEAR PROGRAMMING

Mathematical formulation of a problem

Consider the following situation

A furniture dealer deals in only two items tables & chairs. He has Rs, 50,000 to invest and has storage space of 60 pieces, A table costs Rs. 2500 and a chair costs Rs.500. He estimates that from the sale of one table he can make a profit of Rs. 250 and that from sale of one chair a profit of Rs. 75/- He wants to know how many tables & chairs he should buy from the available money so as to maximise the profit.

Solution:

Let x be the no.of tables y be the number of chairs that the dealer buys,

$$\text{thus } x \geq 0 \text{ \& } y \geq 0$$

The dealer is constrained by the maximum amount he can invest & by the no.of items he can store.

$$\text{ie, } 2500x+500y \leq 50000 \Rightarrow 5x+y \leq 100 \text{ \& } x+y \leq 60.$$

The dealer wants to maximise his profit, thus

$$\text{Maximise } Z = 250x+75y$$

Thus the linear programming problem is

$$\text{Maximise } Z = 250x+75y \text{ such that}$$

$$5x+y \leq 100$$

$$x+y \leq 60$$

$$x > 0, y \leq 0$$

Graphical Solution

Consider $5x+y = 100$

x	0	20
y	100	0

$$x+y = 60$$

x	0	60
y	60	0

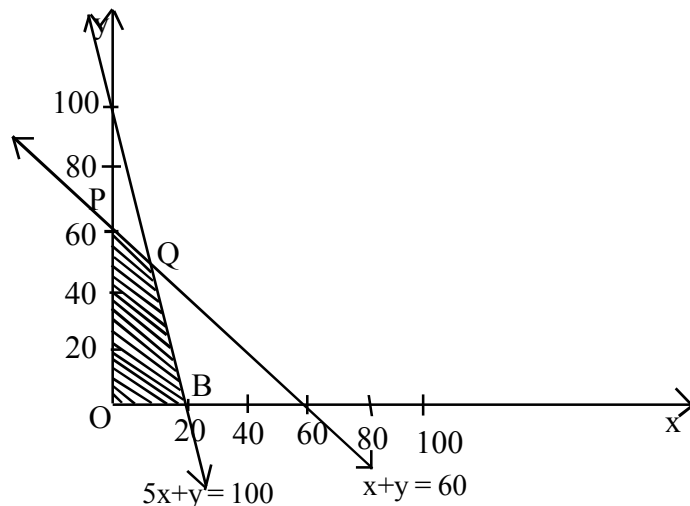

The shaded region is the feasible region.

POBQ is the shaded region.

Co-ordinates are, P(0,60), O(0,0), B(20,0), Q(10,50)

(\therefore Q be the point of intersection of the lines $5x+y = 100$ & $x+y = 60$)

Solve $5x+y = 100$(1)

$$x+y = 60$$
.....(2)

$$(2)-(1) \quad 4x = 40$$

$$\Rightarrow x=10$$

(To find the Co-ordinates of Q we have to solve the equation)

$$5x+y=100 \quad \& \quad x+y = 60$$

$$4x = 40$$

$$\Rightarrow x=10 \quad \text{from } x+y = 60, \quad y=50$$

At P(0,60), $Z=250x0 + 75x60 = 4500$

$$O (0,0) \quad Z= 250x0 + 75x0 = 0$$

at Q (10,50), $Z= 250x10+75x50 = 6250$

at B (10,0), $Z= 250 x 20+75 x 0 = 5000$

Thus we can see that the maximum profit to the dealer result from investment strategy (10, 50)

Review Questions

1. Solve the linear programming

$$\text{Max } Z= 4x+y \text{ Such that}$$

$$x+y \leq 50$$

$$3x+y \leq 90$$

$$x \geq 0, y \geq 0$$

2. Solve Max $Z=3x+9y$ Such that

$$x+3y \leq 60$$

$$x+y \geq 10$$

$$x \geq 0, y \geq 0$$

15. PROBABILITY

Conditional Probability

Let E and F be any two events associated with a random experiment. The probability of occurrence of event E when the event F has already occurred, is called the conditional probability of E. We denote this by $P(E/F)$.

$$P(E/ F) = \frac{P(E \cap F)}{P(F)}, P(F) \neq 0$$

$$P(F/ E) = \frac{P(E \cap F)}{P(E)}, P(E) \neq 0$$

$$\therefore P(E \cap F) = P(E)P(F/ E) = P(F)P(E/ F)$$

(Multiplication theorem of probability)

Independent Events:

Two events E and F of a random experiment are said to be independent if the occurrence of one event does not affect the probability of occurrence of other.

In this case $P(E/F)=P(E)$ and $P(F/E) = P(F)$. If E and F are independent $P(E \cap F) = P(E)P(F)$.

Eg:-

- (i) In the experiment of throwing a die, event of getting an even number and event of getting a number <5 are independent.
- (ii) In the experiment of drawing cards the event of getting a spade card and event of getting a king card are independent.

Partition of Sample Space:

A set of events E_1, E_2, \dots, E_n is said to represent a partition of the sample space S if

- a) $E_i \cap E_j = \phi, i \neq j \quad i, j = 1, 2, 3, \dots, n$
- b) $E_1 \cup E_2 \cup \dots \cup E_n = S$
- c) $P(E_i) > 0 \quad \forall i = 1, 2, \dots, n.$

Thus the events E_1, E_2, \dots, E_n represent a partition of the sample space S if they are pairwise disjoint, exhaustive and have non-zero probabilities.

Theorem of total probability

Let E_1, E_2, \dots, E_n be n mutually exclusive, exhaustive events with non-zero probabilities of an experiment.

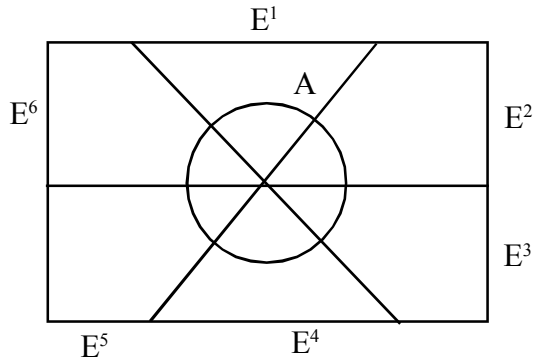

Let A be any event associated with the sample space S.

$$\text{Then } A = AE_1 \cup AE_2 \cup \dots \cup AEn$$

$$\therefore P(A) = P(AE_1) + P(AE_2) + \dots + P(AEn)$$

$$= P(E_1)P\left(\frac{A}{E_1}\right) + P(E_2)P\left(\frac{A}{E_2}\right) + \dots + P(E_n)P\left(\frac{A}{E_n}\right)$$

$$\therefore P(A) = \sum P(E_i)P\left(\frac{A}{E_i}\right)$$

Eg:- Consider the experiment of throwing a die

Let $E_1 = \{1\}$, event of getting a no < 2 .

$E_2 = \{2, 4, 6\}$, event of getting an even number.

$E_3 = \{3, 5\}$, event of getting an odd prime.

Here $E_i \cap E_j = \phi$ and $E_1 \cup E_2 \cup E_3 = S$

Also $P(E_i) > 0$.

$\therefore \{E_1, E_2, E_3\}$ is a partition of S.

Let $A = \{1, 2, 3, 6\}$ event of getting a divisor of 6.

$$A = (E_1 \cap A) \cup (E_2 \cap A) \cup (E_3 \cap A)$$

$$P(A) = P(E_1 \cap A) + P(E_2 \cap A) + P(E_3 \cap A)$$

$$= P(E_1)P\left(\frac{A}{E_1}\right) + P(E_2)P\left(\frac{A}{E_2}\right) + P(E_3)P\left(\frac{A}{E_3}\right)$$

$$P(A) = \sum_{i=1}^3 P(E_i)P\left(\frac{A}{E_i}\right)$$

Bayes' Theorem:

$$P\left(\frac{E_1}{A}\right) = \frac{P(E_1)P\left(\frac{A}{E_1}\right)}{\sum P(E_i)P\left(\frac{A}{E_i}\right)}$$

Proof:

$$\text{We have } P(E_1/A) = \frac{P(A \cap E_1)}{P(A)}$$

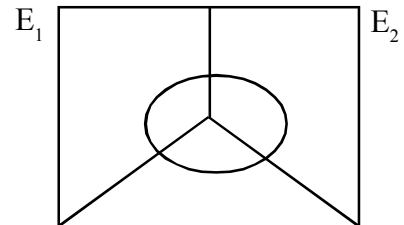

$$= \frac{P(E_1)P\left(\frac{A}{E_1}\right)}{\sum_{i=1}^n P(E_i)P(A/E_i)}$$

When $n = 2$

$$P(E_1/A) = \frac{P(E_1)P(A/E_1)}{P(E_1)P(A/E_1) + P(E_2)P(A/E_2)}$$

$$P(E_2/A) = \frac{P(E_2)P(A/E_2)}{P(E_1)P(A/E_1) + P(E_2)P(A/E_2)}$$

Probability Distribution

A random variable 'X' is a number associated with the outcomes of a random experiment. Let 'X' be a random variable assuming values x_1, x_2, \dots, x_n corresponding to various outcomes of a random experiment.

If $P(X=x_i) = P_i$, the set $\{P_1, P_2, \dots, P_n\}$ is called the probability distribution of x , where $P_i > 0$ and $\sum P_i = 1$. It is also called the expectation of X denoted by $E(X)$.

$$\therefore E(X) = \sum X_i P_i$$

$$E(X^2) = \sum X_i^2 P_i$$

To find $V(X)$ we can use the formula

$$V(x) = E(X^2) - [E(X)]^2$$

(Proof: $V(x) = \sum (x_i - \mu)^2 P_i$

$$= \sum (x_i^2 + \mu^2 - 2\mu x_i) P_i$$

$$= \sum x_i^2 P_i + \mu^2 \sum P_i - 2\mu \sum x_i P_i$$

$$= \sum x_i^2 P_i + \mu^2 - 2\mu \sum x_i P_i = 1 \text{ and } \sum x_i P_i = \mu$$

$$= \sum x_i^2 P_i - (\sum x_i P_i)^2$$

$$= E(X^2) - [E(X)]^2$$

$\sqrt{V(x)}$ is called the standard deviation of the variable X.

Bernoulli Trials and Binomial Distribution

The trials of a random experiment are Bernoulli trials, if they satisfy the following conditions.

- (i) There should be a finite number of trials.
- (ii) The trials should be independent.

- (iii) Each trial has exactly 2 outcomes, success or failure
- (iv) The probability of success in each trial remains same.

If $P(\text{Success}) = p$, then $P(\text{not success}) = 1 - p$
 $= q$, say

$$\therefore p + q = 1$$

The probability of x success in ' n ' Bernoulli trials is given by

$$P(X=x) = {}^n C_x p^x q^{n-x}$$

The probability distribution of number of success in an experiment consisting of ' n ' Bernoulli trials may be obtained by the binomial expansion of $(q+p)^n$.

X	0	1	2	x	N
P(x)	${}^n C_1$	${}^n C_1 q^{n-2} p$	${}^n C_2 q^{n-2} p^2$	${}^n C_x q^{n-x} p^x$	p^x

This probability distribution is known as Binomial Distribution with parameters ' n ' and ' p '.

Mean of the binomial distribution = np

Variance of the binomial distribution = npq .

Examples:

1. A bag contains 7 black and 5 white balls. Two balls are drawn from the bag one after the other without replacement, what is the probability that both drawn balls are white?

Let E and F denote respectively the events first and second ball drawn are white.

Required probability = $P(E \cap F)$

$$= P(E) P(F/E)$$

$$= \frac{5}{12} \times \frac{4}{11}$$

$$= \frac{5}{33}$$

2. Two cards are drawn successively with replacement from a well shuffled pack of 52 cards. Let X denote the number of aces.

(i) Write the prob. distribution of X .

(ii) Find the mean, variance and standard deviation of X .

' X ' can take values 0, 1, 2

$$P(X=0) = P(\text{both non-aces}) = \frac{45}{52} \times \frac{48}{52} = \frac{144}{169}$$

$$P(X=1) = P(\text{ace, non-ace OR non-ace, ace})$$

$$= \frac{4}{52} \times \frac{48}{52} + \frac{48}{52} \times \frac{4}{52} = \frac{24}{169}$$

$$P(X=2) = P(\text{both aces})$$

$$= \frac{4}{52} \times \frac{4}{52} = \frac{1}{169}$$

Probability distribution is

X	0	1	2
P(x)	$\frac{144}{169}$	$\frac{24}{169}$	$\frac{1}{169}$

$$\mu = E(x) = \sum xi Pi$$

$$= 0X \frac{144}{169} + 1X \frac{24}{169} + 2X \frac{1}{169}$$

$$= \frac{2}{13}$$

$$\text{Also } E(x^2) = \sum xi^2 pi$$

$$= 0^2 X \frac{144}{169} + 1^2 X \frac{24}{169} + 2^2 X \frac{1}{169}$$

$$= \frac{18}{169}$$

$$V(X) = E(x^2) - [E(X)]^2$$

$$= \frac{18}{169} - \frac{4}{169} = \frac{14}{169}$$

$$\text{Standard Deviation} = \sqrt{V(X)}$$

$$= \sqrt{\frac{14}{169}}$$

$$= 0.3768$$

3. If $P(A) = \frac{2}{3}$, $P(\bar{B}) = \frac{3}{4}$ and $P(A|B) = \frac{4}{5}$ Find $P(A \cup B)$

$$P(A \cup B) = P(A) + P(B) - P(A \cap B)$$

$$= P(A) + P(B) - P(B)P(A|B)$$

$$= \frac{2}{3} + \frac{1}{4} - \frac{1}{4} \times \frac{4}{5}$$

$$= \frac{43}{60}$$

4. Assume that each new born child is equally likely to be a Boy or Girl. If the family has 2 children, what is the conditional probability that both are girls given that,

(i) The youngest is a girl

(ii) At least one is a girl

Here $S = \{BG, GB, BB, GG\}$

(i) Let A: Both are girls

B: Youngest is a girl.

Then $A = \{GG\}$ $B = \{BG, GG\}$

$$P(A) = \frac{1}{4} \quad P(B) = \frac{1}{2} \quad P(A \cap B) = \frac{1}{4}$$

$$P(A|B) = \frac{P(A \cap B)}{P(B)} = \frac{\frac{1}{4}}{\frac{1}{2}} = \frac{1}{2}$$

(ii) Let C : Atleast one is a girl.

Then $C = \{BG, GB, GG\}$

$$P(C) = \frac{3}{4}, P(A \cap C) = \frac{1}{4}$$

$$P(A|C) = \frac{P(A \cap C)}{P(C)} = \frac{\frac{1}{4}}{\frac{3}{4}} = \frac{1}{3}$$

5. A bag contains 3 red balls and 2 white balls and another bag contains 4 red balls and 3 white balls. One ball is transferred from the first bag to the second bag and then one ball is drawn from the second bag.

(i) What is the probability that the drawn ball is red.

(ii) If the drawn ball is found to be red, what is the probability that the transferred ball is white?

We define,

E_1 : Transferring a Red ball

E_2 : Transferring a white ball

A : Drawing a red ball.

$$\begin{aligned} \text{(i)} \quad P(A) &= P(E_1 A \text{ or } E_2 A) \\ &= P(E_1 A) + P(E_2 A) \\ &= P(E_1) P(A/E_1) + P(E_2) P(A/E_2) \\ &= \frac{3}{5} \times \frac{5}{8} + \frac{2}{5} \times \frac{4}{8} \\ &= \frac{23}{10} \end{aligned}$$

$$\begin{aligned} \text{(ii)} \quad P(E_2|A) &= \frac{P(E_2)P(A|E_2)}{P(E_1)P(A|E_1) + P(E_2)P(A|E_2)} \\ &= \frac{8}{23} \end{aligned}$$

Problem:

1. Consider the experiment of throwing a die, Let A be the event of getting an even number, and B be the event of getting a multiple of 3. Show that A and B are independent.

(Hint: Prove $P(A \cap B) = P(A).P(B)$)

2. Find the mean and variance of the number obtained on a throw of an unbiased die.

$$(Mean = \frac{21}{6}, Variance = \frac{25}{12})$$

3. Bag I contains 3 red and 4 black balls, Bag II contains 5 Red and 6 Black balls. One ball is drawn from one of the bags and it is found to be red. Find the probability that it was drawn from Bag II.

$$(Ans: \frac{35}{68})$$

4. A die is thrown 6 times. If getting an odd number is a success, what is the probability of,

- (i) 5 Success
- (ii) At least 5 successes
- (iii) At most 5 successes.

$$Ans : [(i) \frac{3}{32} (ii) \frac{7}{64} (iii) \frac{63}{64}]$$

5. Find the probability distribution of the number of double in 3 throws of a pair of dice.

Ans:

X	0	1	2	3
P(X)	$\frac{125}{216}$	$\frac{75}{216}$	$\frac{15}{216}$	$\frac{1}{216}$

UNIT TEST
(Linear Programming & Probability)

- 1) A man is known to speak truth 3 out of 4 times. He throws a die and reports that it is a six. Find the probability that it is actually a six. (3)
- 2) Find the mean number of heads in three tosses of a fair coin (3)
- 3) A & B Throw a die alternatively till one of them gets a 6 and wins the game. Find their respective probabilities of winning if A starts first. (3)
- 4) The graphical solution of an LPP is given below.

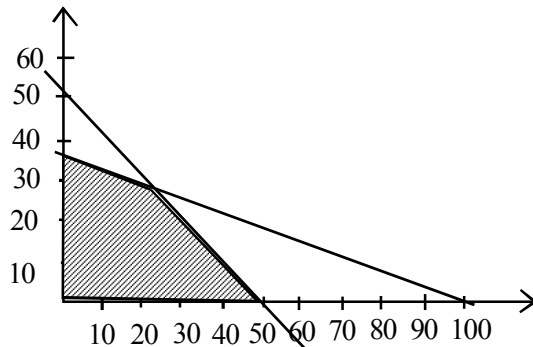

- a) If the shaded region represents the feasible region. Write down their linear equation? (2)
 - b) Determine the co-ordinates of the corner points O, A, B & C (2)
 - c) If $Z=60x+15y$ is the objective function, find maximum Z. (2)
5. If A & B are events such that $A \cap B \neq \emptyset$. Which of the following are correct? (1)
- 1) $P(A/B) = \frac{P(B)}{P(A)}$ 2) $P(A/B) < P(A)$ 3) $P(A/B) \geq P(A)$ 4) None
- 6) A & B are two events such that $P(A^c) = .3$
- a) $P(A) = .4$ and $P(A \cap B) = .1$ then $P(A \cap B^c) = \dots\dots$ (1)
 - b) The probability that A solve the problem is $\frac{1}{2}$ and probability of B solve the problem is $\frac{1}{3}$. If both try to solve the problem independently Find the probability that
 - i) The problem will be solved (2)
 - ii) None of them will solve the problem (1)
