

Main Features

- Advanced visual control panel offers complete customization and versatility of all baking parameters including auto-pilot start up mode, exhaust discharge adjustments, 9 baking programs & top and bottom heating control
- Quickly reaches working temperature of 300°C in less than 30 minutes and 420° in less than 45 minutes
- Double glazed glass door along with sealing fiber chamber gaskets & glass fiber insulation prevents burn, reduces any heat loss and allows the user to bake with the door open
- Economy mode forces the ceiling and floor resistors to switch on limiting the required power by 50%
- Fully constructed in high grade (AISI) 304 stainless steel
- Well lit interior chamber light
- No Gap Refractory Stone ensures no difficult-to-clean spots where flour and cheese can get stuck, burn and ruin the taste of the pizza
- Modular so can be stacked up to 3 units high



IWOS™ Italian Wood SYSTEM Oven Substitute

KING is the only oven in the world baking with the innovative IWOS™ System (Italian Wood Oven Substitute) which mechanically replicates the air circulation found within a wood-burning pizza oven.

SPECIFICATIONS

Voltage	400 Volt AC 3/N/PE
	230 Volt AC 1/N/PE
Power	5.6 kw
Weight	167 kg
Plug Supplied	NO
Capacity	4 x 34cm pizza
Thermostat	60-500°C
Warranty	4 Year Warranty (2 yr Labour 4 yr Parts)

DIMENSIONS

External Width	1135mm	Internal Width	700mm
External Depth	1140mm	Internal Depth	700mm
External Height	425mm	Internal Height	155mm

ACCESSORIES

Single Deck Stand	AFOPIEDAZ4NR1M
Double Deck Stand	AFOPIEDAZ4NR2M
Triple Deck Stand	AFOPIEDAZ4NR3M
Extractor Hood	AFOCAPKING4
Double Door Prover Insert	AFOCELUN

KING 4

FOR KING4GTR400

FRONT

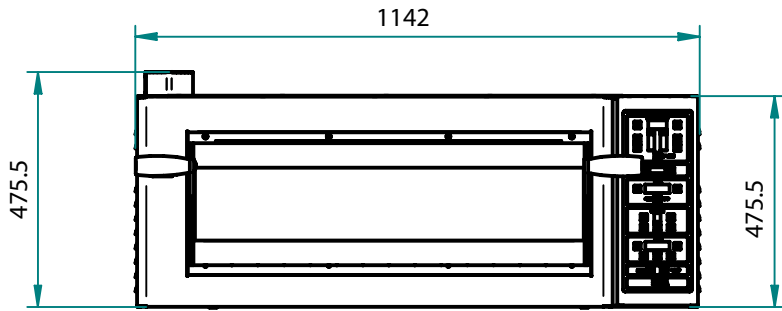

SIDE

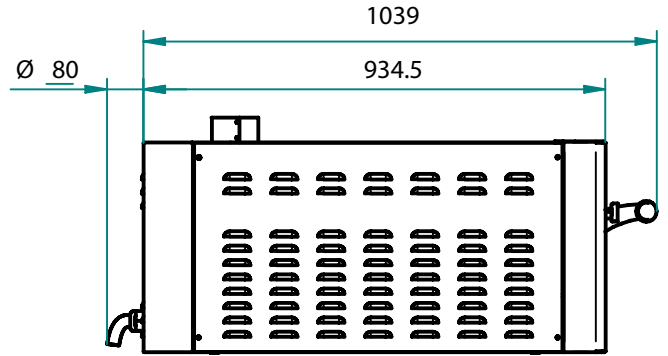

TOP

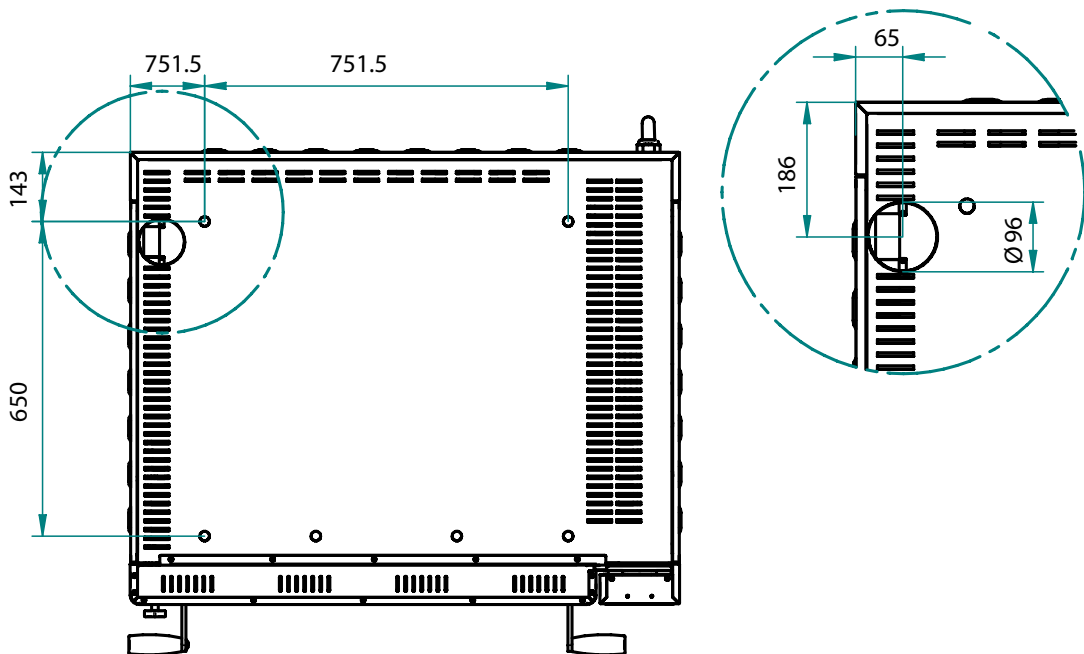

We reserve the right to alter specifications without notice.



THE
GOOD
LADY

Phone: 1800 183 818 Email: support@thegoodlady.com.au
Website: www.thegoodlady.com.au

KING 4 - EXTRACTOR HOOD

FORKING4GTR400

AFOCAPKING4

FRONT

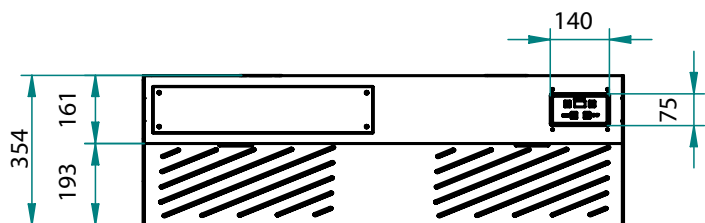

SIDE

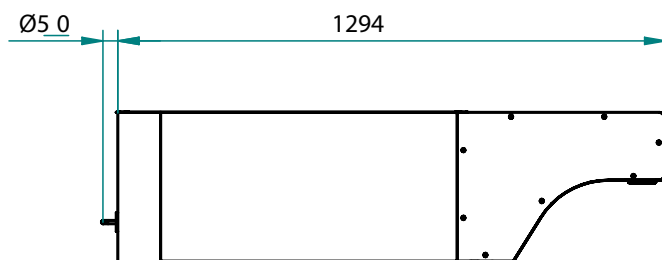

TOP

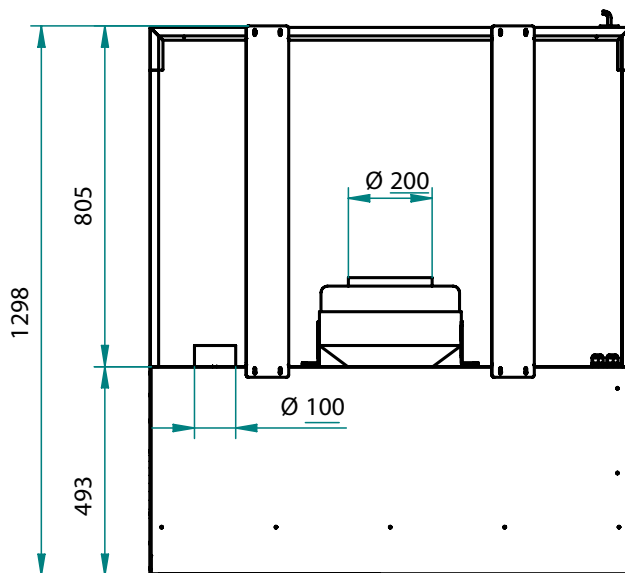

We reserve the right to alter specifications without notice.



THE
GOOD
LADY

Phone: 1800 183 818 Email: support@thegoodlady.com.au
Website: www.thegoodlady.com.au

KING 4 - SINGLE DECK STAND

FORKING4GTR400

AFOPIEDAZ4NR1M

FRONT

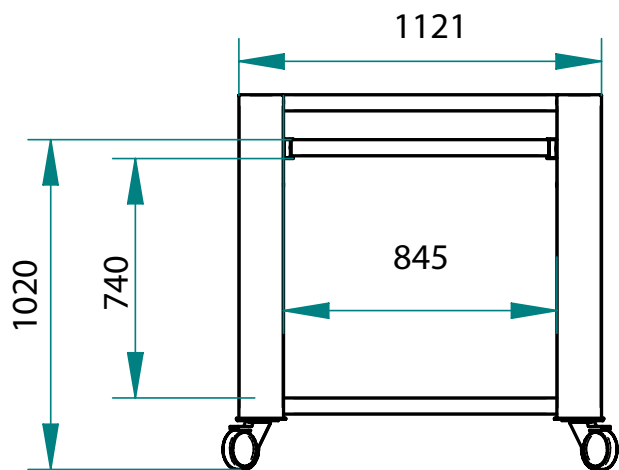

SIDE

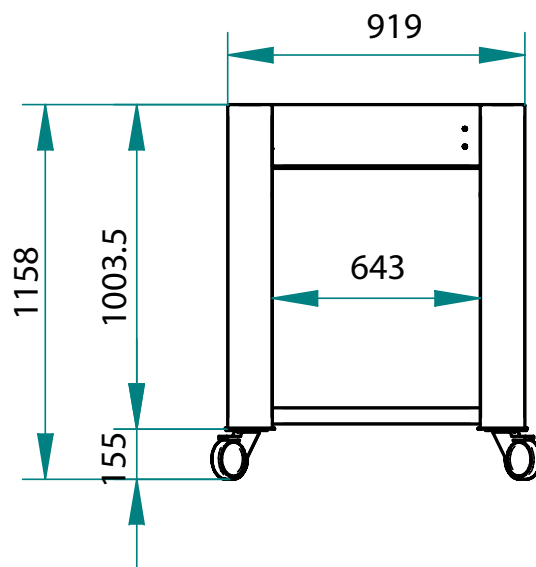

TOP

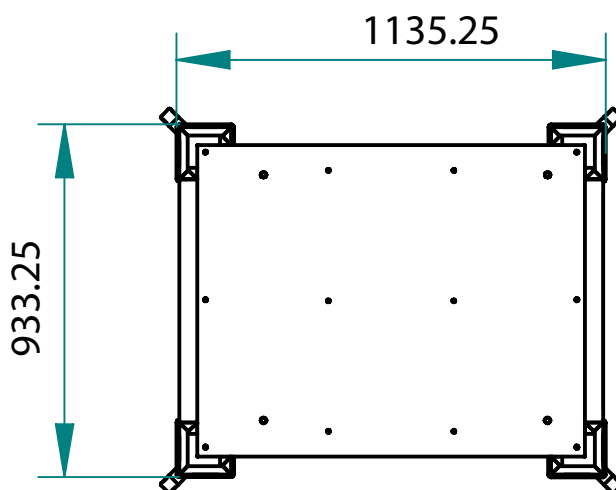

We reserve the right to alter specifications without notice.



THE
GOOD
LADY

Phone: 1800 183 818 Email: support@thegoodlady.com.au
Website: www.thegoodlady.com.au

KING 4 - DOUBLE DECK STAND

FORKING4GTR400

AFOPIEDAZ4NR2M

FRONT

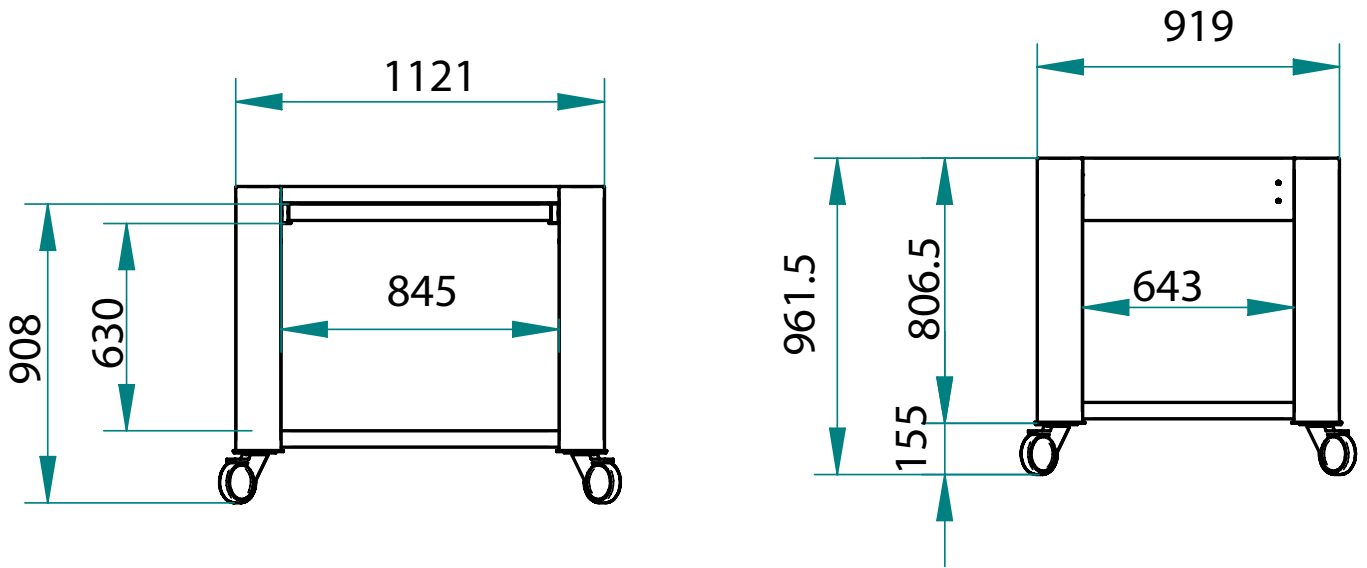

TOP

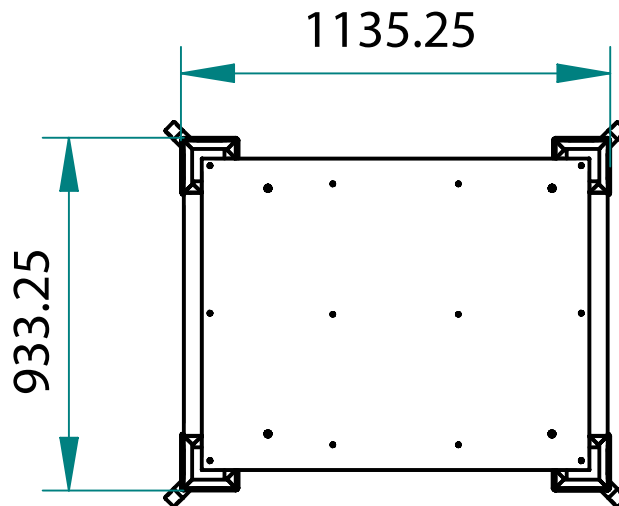

We reserve the right to alter specifications without notice.



THE
GOOD
LADY

Phone: 1800 183 818 Email: support@thegoodlady.com.au
Website: www.thegoodlady.com.au

KING 4 - TRIPLE DECK STAND

FOR KING4GTR400 AFOPIE DAZ4NR3M

FRONT

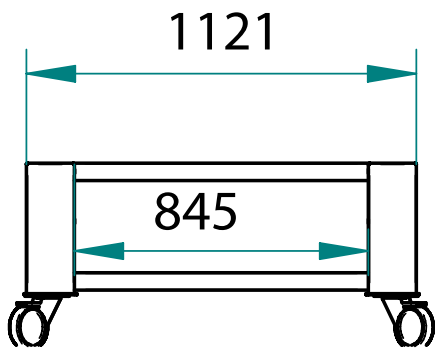

SIDE

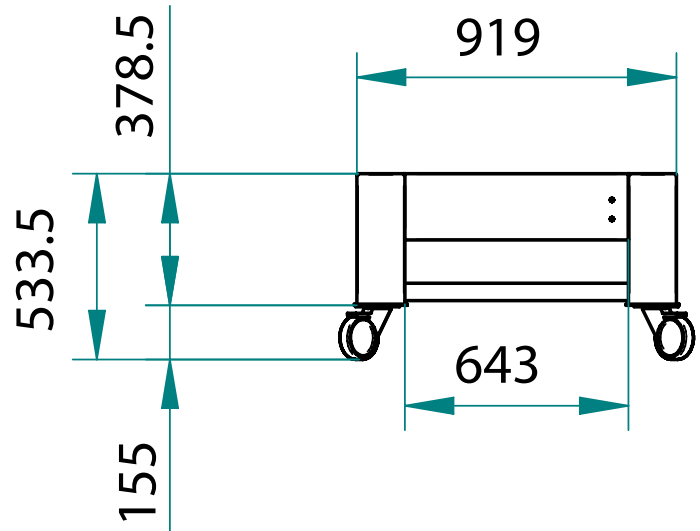

TOP

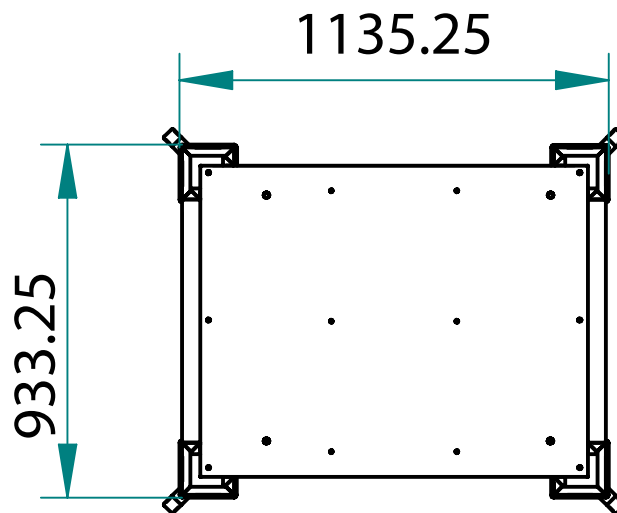

We reserve the right to alter specifications without notice.



THE
GOOD
LADY

Phone: 1800 183 818 Email: support@thegoodlady.com.au
Website: www.thegoodlady.com.au

KING 4 - DOUBLE DOOR PROOFER

FOR KING4GTR400 AFOCELUN

FRONT

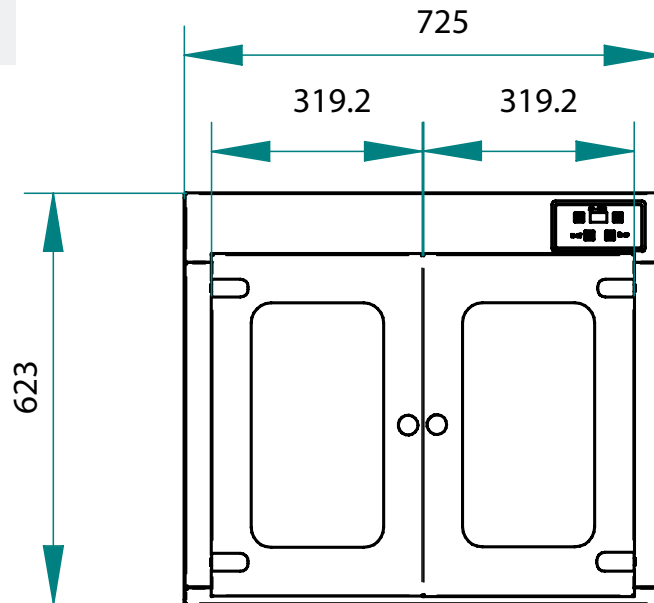

TOP

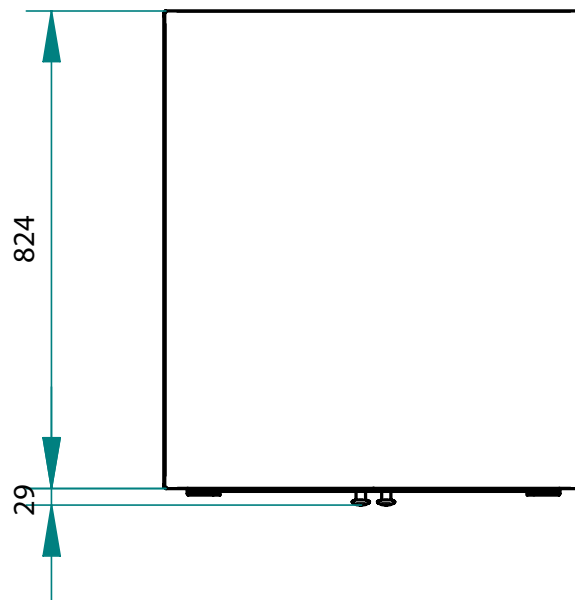

We reserve the right to alter specifications without notice.