

# AVGVSTO 9 ELECTRIC DOME OVEN

## 2CT3E24B



## Main Features

- Fits 9 x 33cm pizzas
- Patented AIR TRAP SYSTEM delivers upto 30% energy saving
- Cooking chamber entirely lined with refractory ceramic
- Rockwool thermal insulation for high temperatures
- Reaches maximum temp. of 500°C in 90 minutes
- Independent adjustment of the temperature of the oven top and bottom with dual probe
- Independent adjustment of the power of the oven top and bottom (scale 0-100%)
- LED interior lighting
- Thermal insulation for high temperatures
- 45 cm antiqued black granite support surface
- Painted base, mounted on wheels or feet
- Can be dismantled in 5 macro-pieces for ease of installation
- Concealable electromechanical control panel
- Customisable dome colours
- 15cm diameter fitting prepared for an easy connection to the central suction system



## SPECIFICATIONS

Voltage	Current at 400Vac 3N 50/60Hz - 28 Amps
Max Power	19200 Watts
Avg Power	9600 Watts
Plug Supplied	No, lead only
Weight	550 kg
Refractory Floor thickness	3cm
Capacity	9 x 34cm pizzas
Exhaust Pipe	150mm
Thermostat	500°C
Ambient Temp	0-40°C
Max Humidity	95% without condensation
Warrenty	4 Year Warranty (2 yr Labour 4 yr Parts)

AIR TRAP SYSTEM® is a patented technology that creates an air barrier right before the mouth of the oven and keeps the heat inside the cooking chamber.

### Advantages of Air Trap System

Energy saving -20% lower power consumption for a daily production cycle of 8 hours

- Up to 30% lower power consumption for a daily production cycle of more than 8 hours
- Superbly even baking, guaranteed even close to the mouth of the oven

working ergonomics at the top, eliminating the excessive heat that surrounds the pizza maker

## ACCESORIES

Base closed on 3 sides  
Retractable Rack for Peels with Tools  
Dome colour customizable upon order:  
RED, BLUE, GOLD\*  
Unpainted white dome, customizable by the client

## DIMENTIONS

External Width	1910mm	Internal Width	1040mm
External Depth	2120mm	Internal Depth	1060mm
External Height	2185mm	Internal Height	125mm



Phone: 1800 183 818 Email: support@thegoodlady.com.au  
Website: www.thegoodlady.com.au

# AUGUSTO 9 ELECTRIC DOME OVEN

2CT3E24B

## FRONT

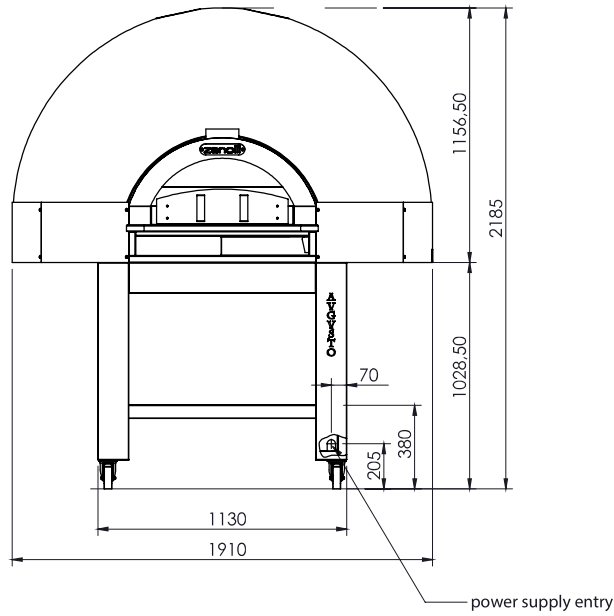

## SIDE

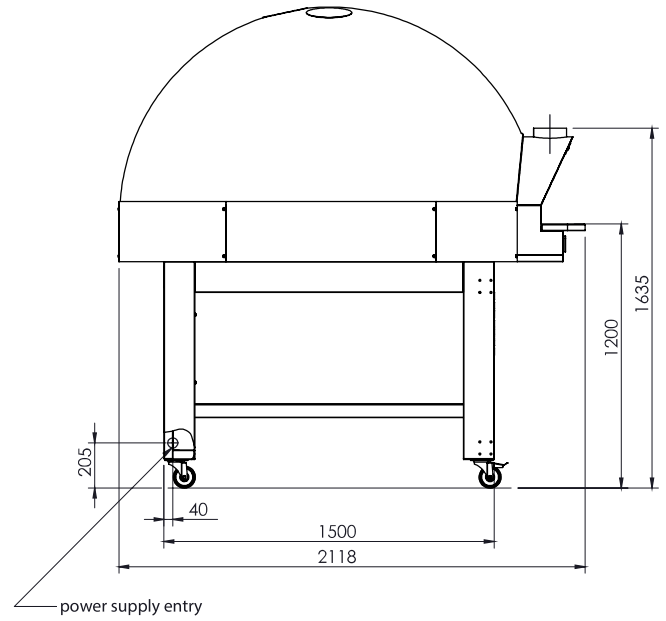

## TOP

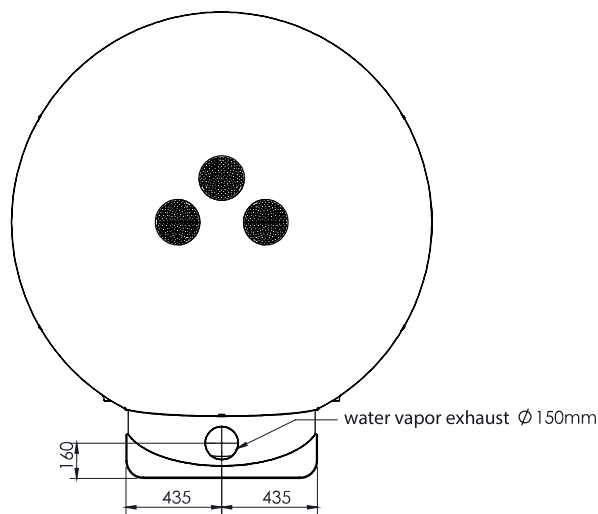

We reserve the right to alter specifications without notice.



Phone: 1800 183 818 Email: [support@thegoodlady.com.au](mailto:support@thegoodlady.com.au)  
Website: [www.thegoodlady.com.au](http://www.thegoodlady.com.au)

# AUGUSTO 9 ELECTRIC DOME OVEN

2CT3E24B

## FRONT

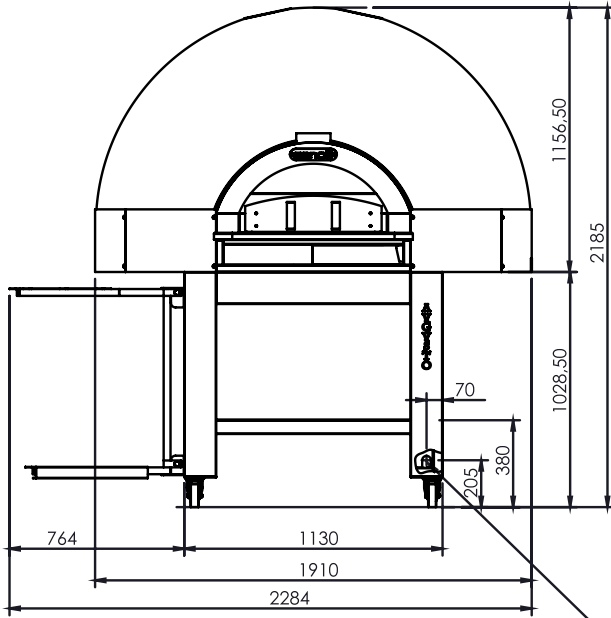

## SIDE

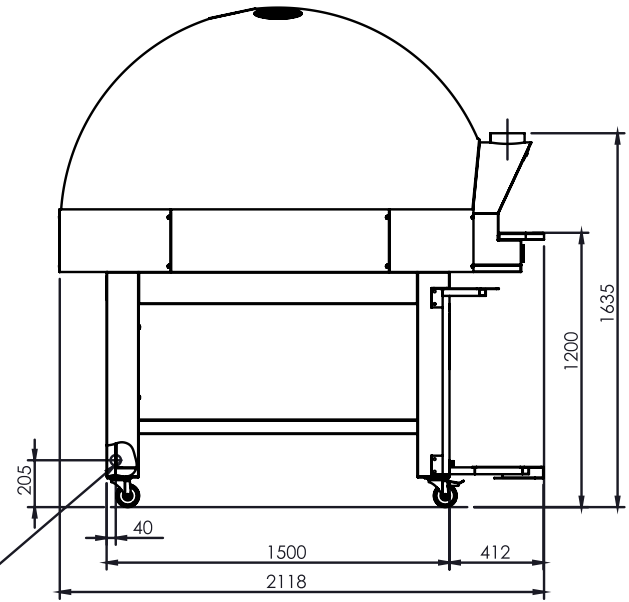

ingresso alimentazione elettrica / power supply entry

## TOP

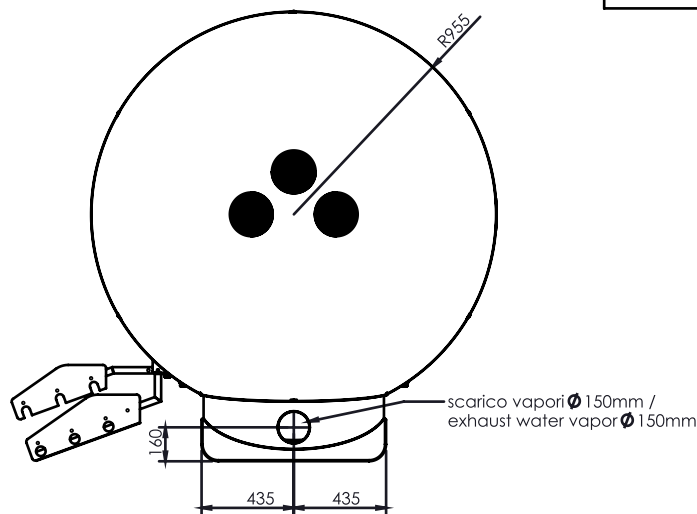

MOD.	Potenza kW/ Power kW
AUGUSTO 9E	19.2

We reserve the right to alter specifications without notice.



THE  
GOOD  
LADY

Phone: 1800 183 818 Email: support@thegoodlady.com.au  
Website: www.thegoodlady.com.au