

MANUAL DE MONTAGEM

ASSEMBLY INSTRUCTIONS

INSTRUCCIONES DE MONTAJE

NOTICE DE MONTAGE

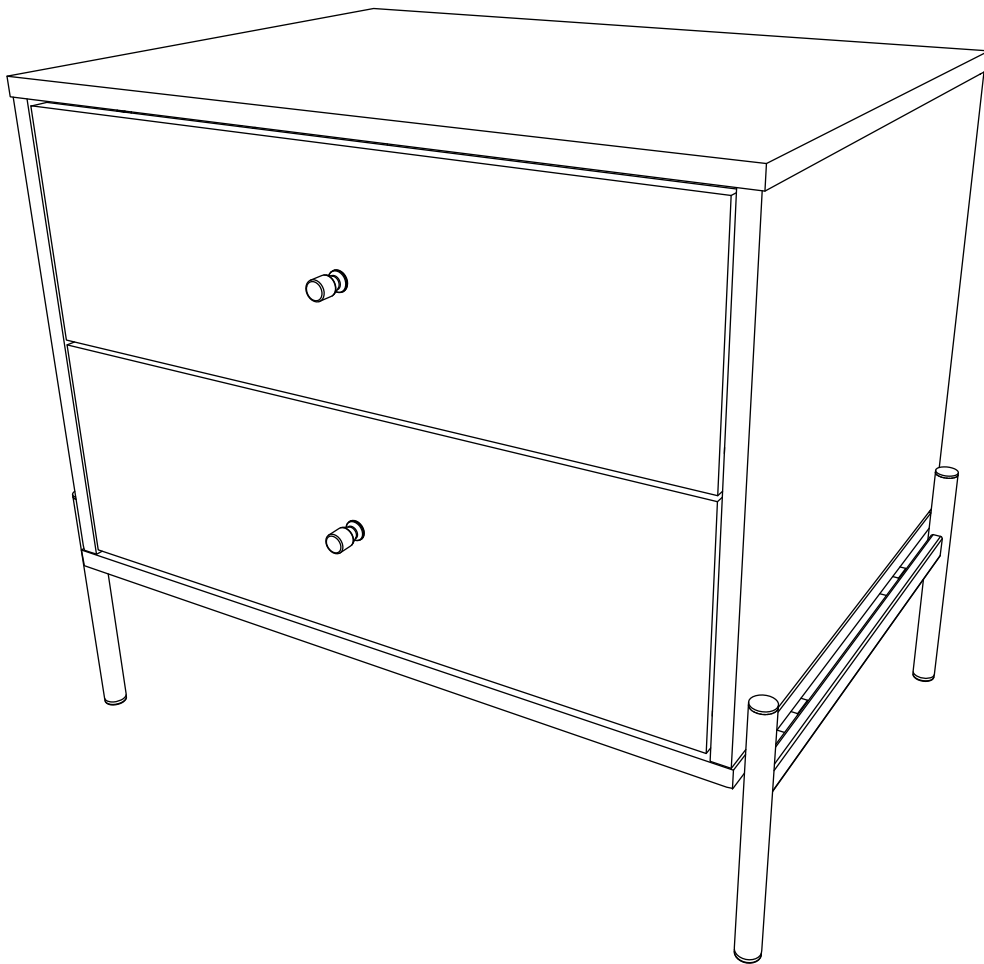

COD:51300

REV. 02 - 26/04/23

OBSERVAÇÕES IMPORTANTES IMPORTANT REMARKS OBSERVACIONES IMPORTANTES REMARQUES IMPORTANTES



Nunca escale ou se apoie sobre o móvel. Você pode sofrer graves acidentes.

Never climb or lean on the furniture. You may suffer serious accidents.

Nunca escale o apoye sobre el mobiliario. Usted puede sufrir graves accidentes.

Ne montez jamais sur le meuble. Vous pourriez subir un grave accident.

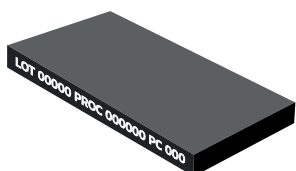

Observe os números impressos nas bordas para identificar as peças.

Identify the parts by observing the number printed on their edges.

Identifique las piezas observando el número impreso en sus bordes.

Notez les numéros imprimés sur les bords pour identifier les pièces.



Movimente o móvel com cuidado, sem arrastar. Peça ajuda a outra pessoa para fazê-lo.

Move the piece carefully, don't drag it. Ask for someone else's help to do so.

Mover la unidad con cuidado, sin arrastar. Pedir ayuda da otra persona para moverlo.

Déplacez les meubles avec précaution sans le faire glisser. Demandez a quelqu'un de vous aider à le faire.

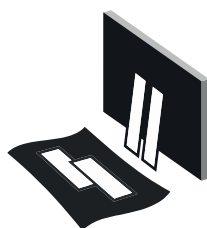

Utilize a embalagem para forrar a área de montagem e separar todas as peças.

Use the packaging to cover the assembly area and separate all parts.

Utilice el embalaje para cubrir la area de montaje y separe las piezas.

Couvrez la zone d'assemblage avec l'emballage pour séparer le pièces.



Limpe com um pano limpo e umedecido em água e sabão neutro. Não utilizar produtos químicos e abrasivos.

Wipe clean using a damp cloth and a mild cleaner. Don't use abrasive and chemical products.

Limpie con un paño limpio humedecido con agua y jabón neutro. No utilice productos químicos y abrasivos.

Nettoyez avec un chiffon propre imbibé avec d'eau et de savon doux. N'utilisez pas de produits chimiques et abrasifs.



Não colocar objetos em alta temperatura diretamente sobre superfícies de vidro.

Do not place high-temperature objects directly on glass surfaces.

No coloque objetos de alta temperatura directamente sobre superfícies de vidro.

Ne placez pas d'objets à haute température directement sur les surfaces en verre.

ACESSÓRIOS HARDWARE HERRAJES ACCESSOIRES

Identifique e separe os acessórios utilizados. Em cada embalagem, uma etiqueta identifica as peças e onde utilizá-las.

Identify and separate the hardware used in the assembly. There's a label on each package identifying the parts and where to use them.

Identifique y separe los accesorios utilizados en el montaje. Observe la etiqueta en cada paquete para saber donde montar.

Identifiez et séparez les accessoires à être utilisés. Dans chaque emballage il y a une étiquette pour identifier les pièces et où les utiliser.

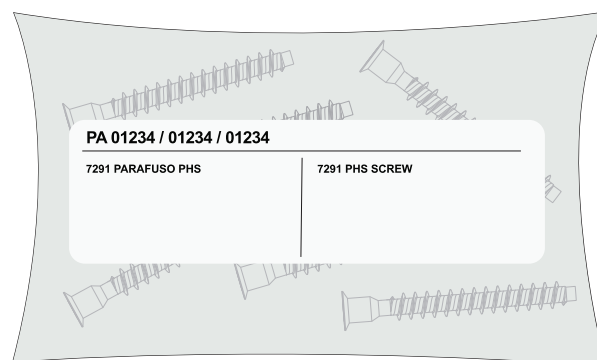

PA51300 - 639 mm









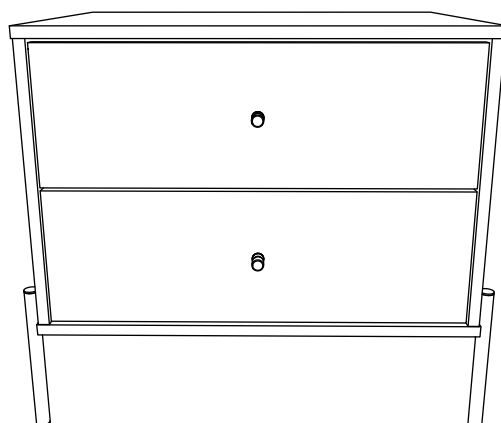

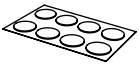
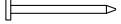
L:639mm A:561mm P:445mm

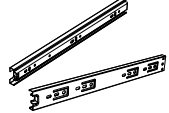
W:25.16in H:22.09in D:17.52in

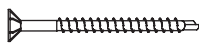
L:639mm A:561mm P:445mm

L:639mm H:561mm P:445mm



<p>A ADESIVO STICKER ADHESIVO AUTOCOLLANT (10X)</p> 	<p>B COD. 0357 8.0 x 8.0 (20X)</p> 	<p>C COD. 10063 (16X)</p> 	<p>D COD. 1668 6.0 x 30 (16X)</p> 	<p>E COD. 2661 (02X)</p> 
<p>F COD. 0599 (16X)</p> 	<p>G COD. 1533 4.0 x 14 (16X)</p> 	<p>H COD. 0715 4.5 x 50 (04X)</p> 	<p>I COD. 3187 M4 x 20 (02X)</p> 	<p>J COD. 9842 M4 x 25 (08X)</p> 
<p>K SAPATA PLÁSTICA PLASTIC STOPPER ALMOHADILLA PLASTICO BOUCHON PLASTIQUE (04X)</p> 	<p>L COD. 13518 (08X)</p> 	<p>M PUXADOR DOOR HANDLE MANIJA POIGNÉE (02X)</p> 		

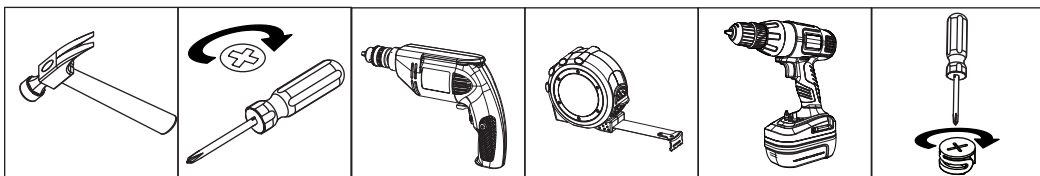

DESCRIÇÃO/ DESCRIPTION/ DESCRIPCIÓN/ DESCRIPTION

CÓD:51300						
PEÇA PART PIEZA	QUANTIDADE QUANTITY CANTIDAD	DESCRIÇÃO	DESCRIPTION	DESCRIPCIÓN	DESCRIPTION	CAIXA BOX CAJA BOÎTE
01	01	BASE	BASE	BASE	BASE	01
02	01	TAMPO	TOP PANEL	PANEL SUPERIOR	PLATEAU	01
03	01	LATERAL ESQUERDA	LEFT SIDE	LATERAL IZQUIERDA	CÔTÉ GAUCHE	01
04	01	LATERAL DIREITA	RIGHT SIDE	LATERAL DERECHA	CÔTÉ DROITE	01
05	01	FUNDO	BACKPLATE	FONDO	FOND	01
61	02	LATERAL GAVETA ESQ.	LEFT DRAWER SIDE	CAJÓN LATERAL IZQ.	CÔTÉ DE TIROIR	01
62	02	LATERAL GAVETA DIR.	RIGHT DRAWER SIDE	CAJÓN LATERAL DER.	CÔTÉ DE TIROIR	01
66	02	CONTRA FUNDO	DRAWER BACK PANEL	CAJÓN INFERIOR	DERRIÈRE	01
67	02	FRENTE GAVETA	DRAWER FRONT	FRENTE DEL CAJÓN	FAÇADE DE TIROIR	01
68	02	FUNDO GAVETA	DRAWER BOTTOM	FONDO DEL CAJÓN	FOND DE TIROIR	01
99	02	BASE DE AÇO	STEEL BASE	BASE DE ACERO	BASE EN ACIER	01

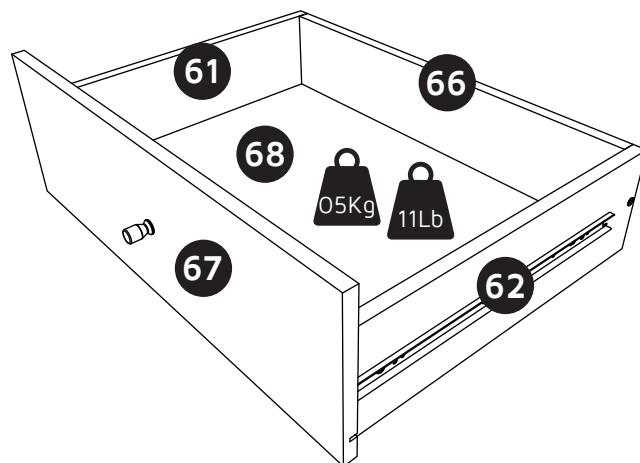
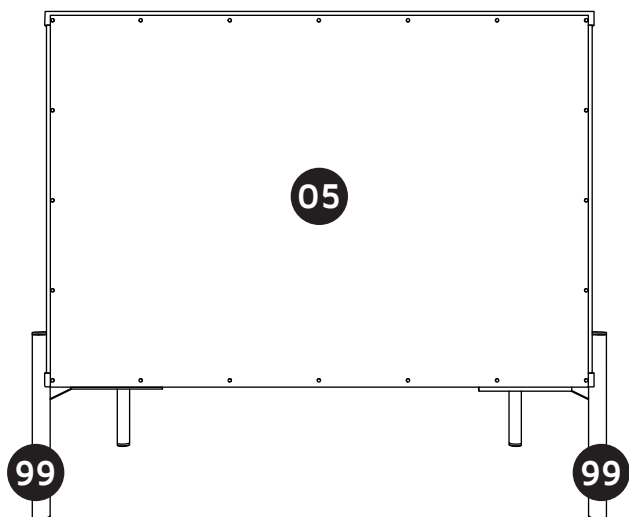
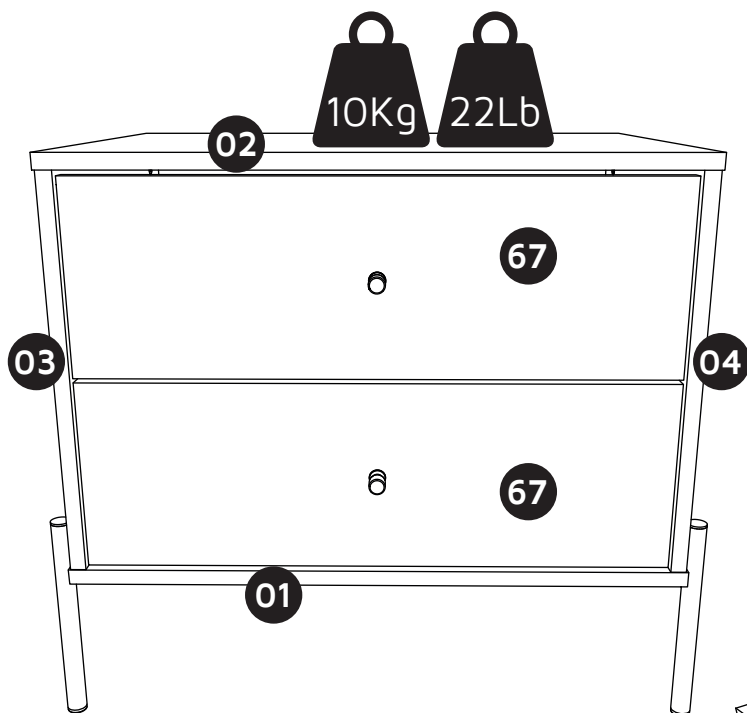

01

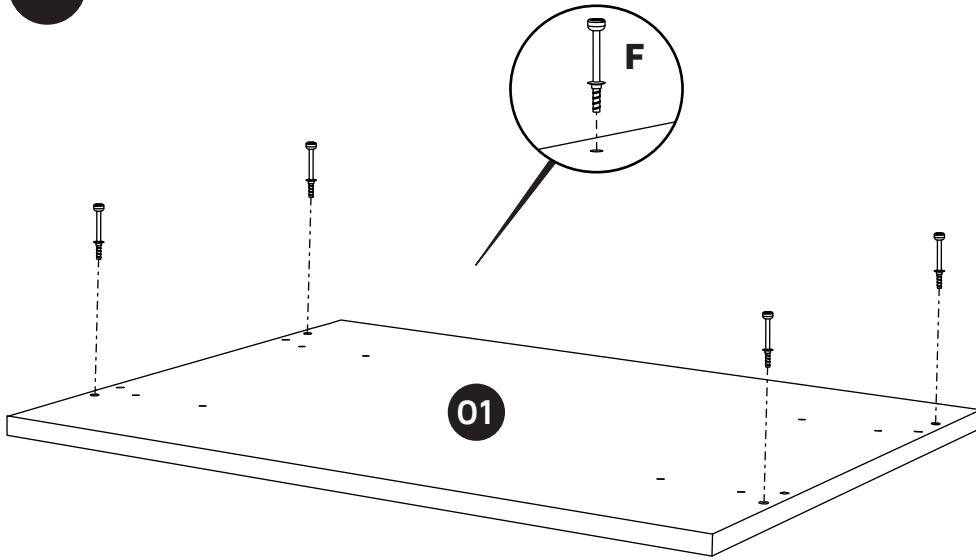

D COD. 1668	F COD. 0599

PASSO 01
Parafusar minifix 4x**0599**
na base **01**.

STEP 01
Screw minifix 4x**0599**
on base **01**.

PASO 01
Atornillar el minifix 4x**0599**
en la base **01**.

ÉTAPE 01
Vissez le minifix 4x**0599**
dans la base **01**.

02

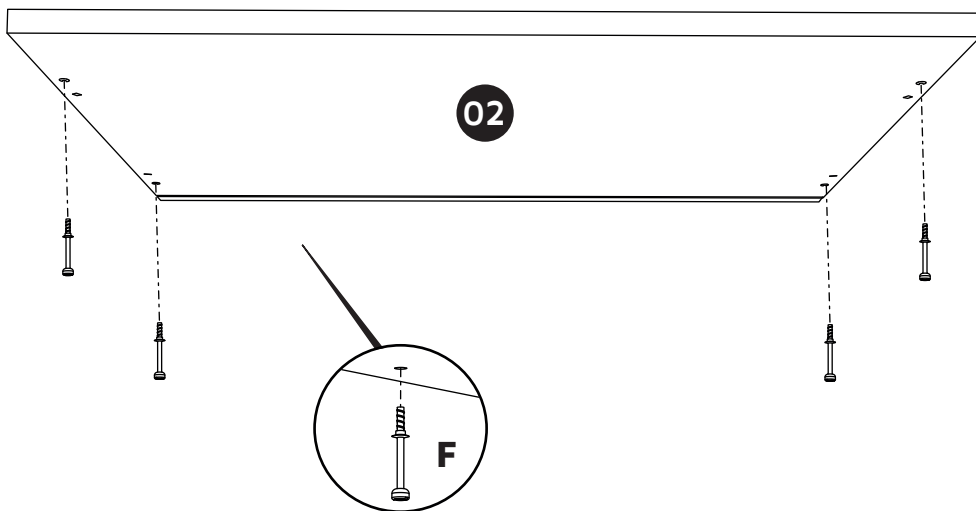

PASSO 02
Parafusar minifix 4x**0599**
no tampo **02**.

STEP 02
Screw minifix 4x**0599**
on top board **02**.

PASO 02
Atornillar el minifix 4x**0599**
en la cubierta **02**.

ÉTAPE 02
Vissez le minifix 4x**0599**
dans le plateau **02**.

03

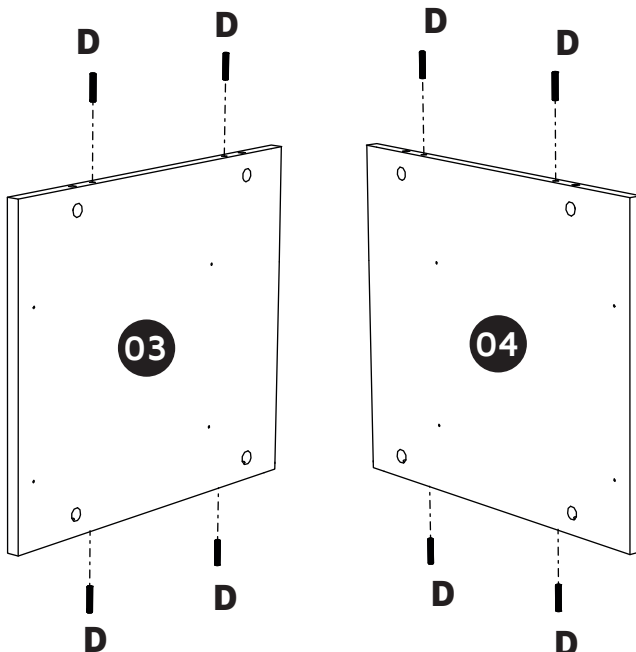

PASSO 03
Encaixar cavilhas 4x**1668** na
lateral esquerda e direita **03/04**.

STEP 03
Insert dowels 4x**1668** on the
left and right side **03/04**.

PASO 03
Clavijas de ajuste 4x**1668** en la
lateral izquierda y derecha **03/04**.

ÉTAPE 03
Insérez les chevilles 4x**1668** sur
les côtés gauche et droit **03/04**.

E COD. 2661	G COD. 1533

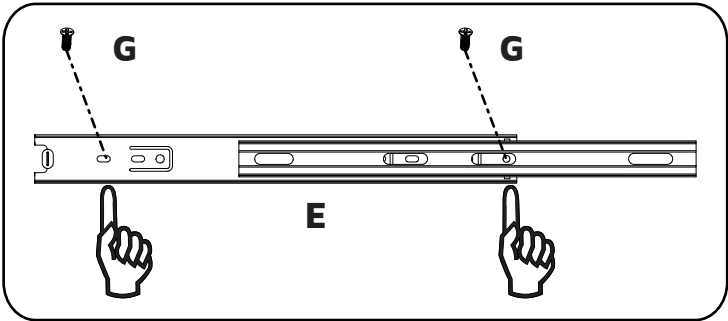

PASSO 04
Parafusar 4x**1533** as corredeças 2x**2661** nas laterais esquerda e direita **03/04**.

STEP 04
Screw 4x**1533** the slides 2x**2661** on the left and right side **03/04**.

PASO 04
Atornillar 4x**1533** las correderas 2x**2661** en las laterales izquierda y derecha **03/04**.

ÉTAPE 04
Vissez 4x**1533** les curseurs 2x**2661** sur les côtés gauche et droit **03/04**.

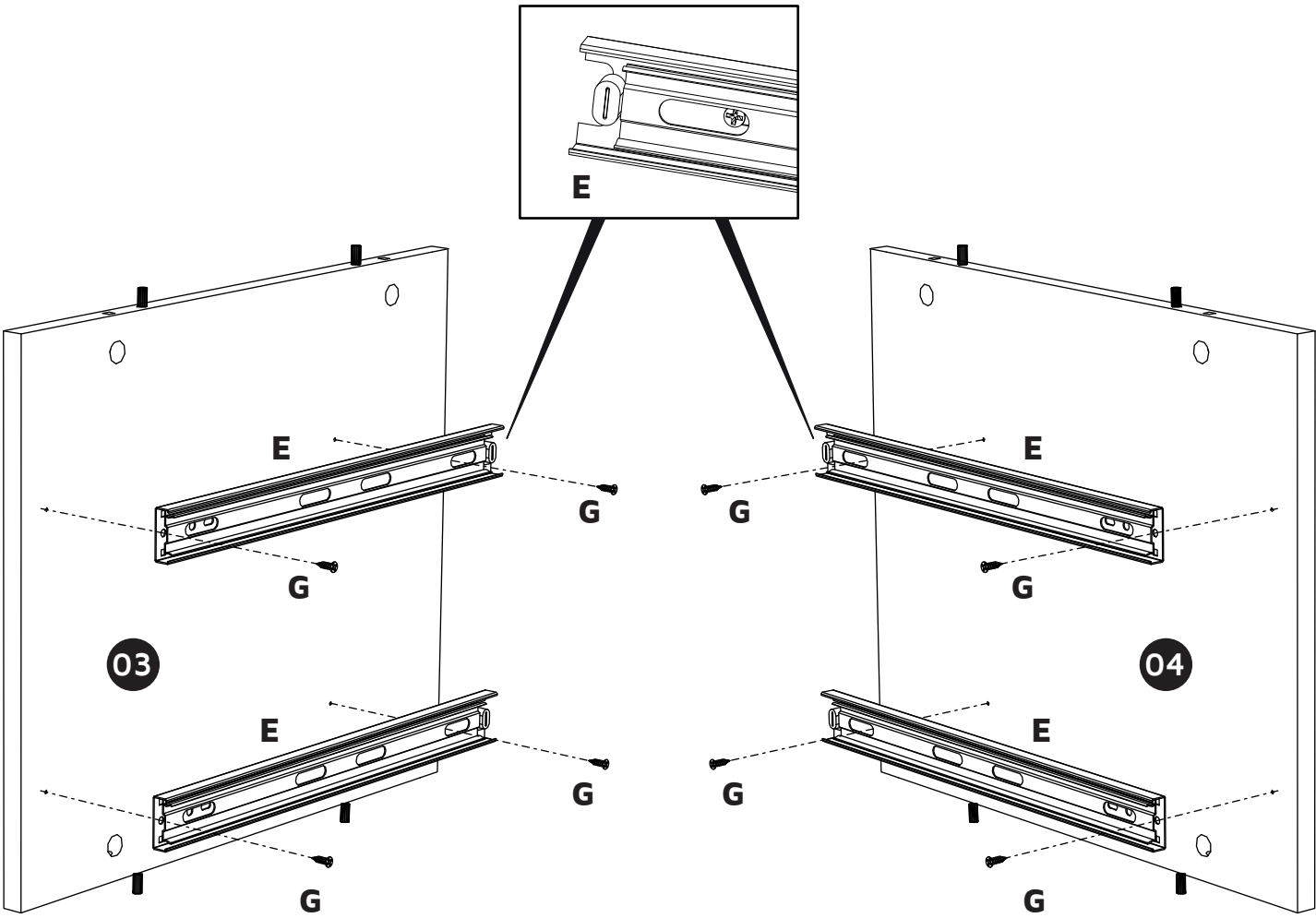

05

C
COD. 10063

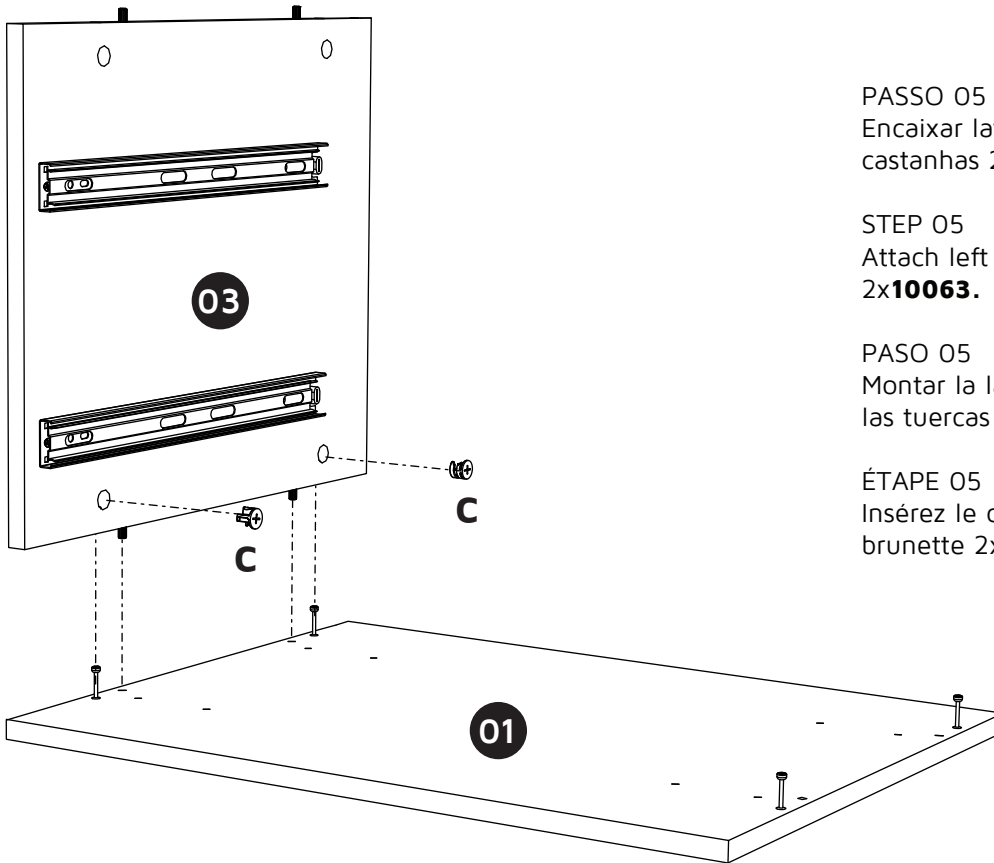

PASSO 05

Encaixar lateral esquerda **03** e parafusar castanhas 2x**10063**.

STEP 05

Attach left side **03** and screw nuts 2x**10063**.

PASO 05

Montar la lateral izquierda **03** y atornillar las tuercas 2x**10063**.

ÉTAPE 05

Insérez le côté gauche **03** et vissez le brunette 2x**10063**.

06

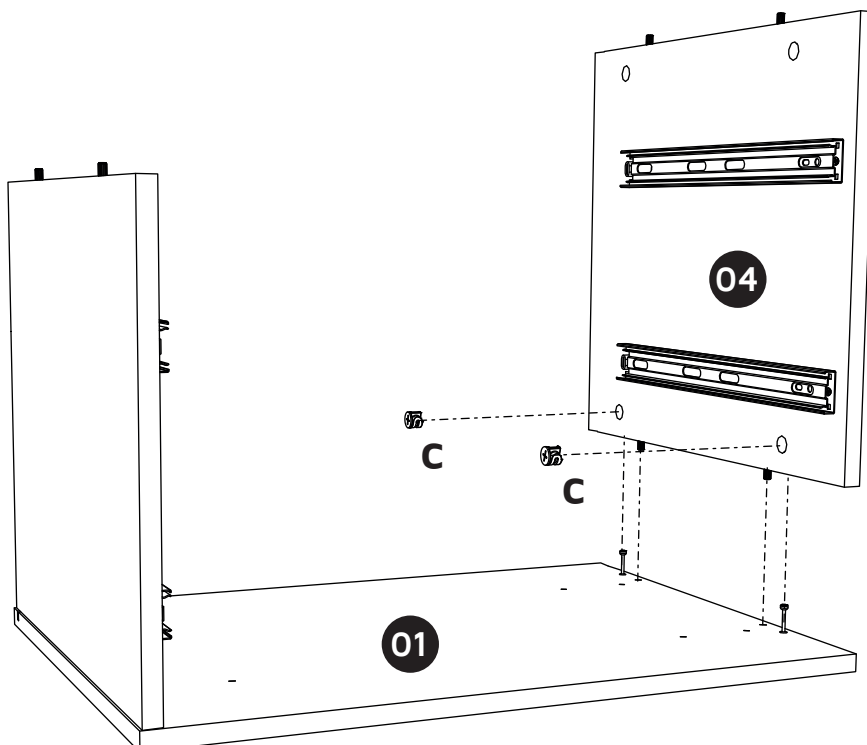

PASSO 06

Encaixar lateral direita **04** e parafusar castanhas 2x**10063**.

STEP 06

Attach right side **04** and screw nuts 2x**10063**.



PASO 06

Montar la lateral derecha **04** y atornillar las tuercas 2x**10063**.

ÉTAPE 06

Insérez le côté droite **04** et vissez le brunette 2x**10063**.

07

B COD. 0357	C COD. 10063
	

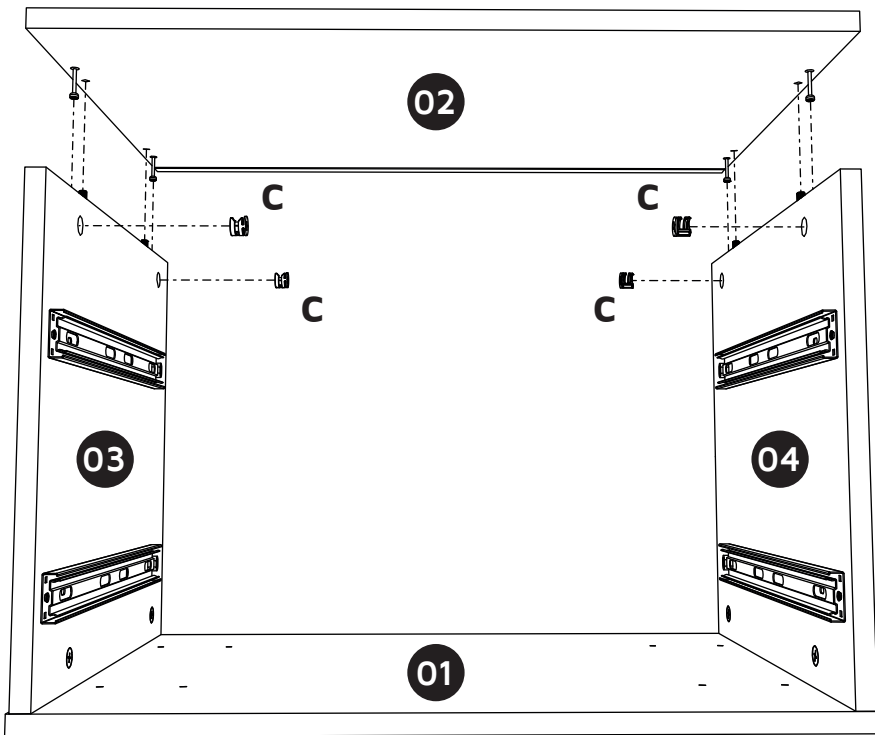

PASSO 07
Encaixar tampo **02** e parafusar castanhas 4x**10063**.

STEP 07
Attach top panel **02** and screw nuts 4x**10063**.

PASO 07
Montar el panel superior **02** y atornillar las tuercas 4x**10063**.

ÉTAPE 07
Insérez le plateau **02** et vissez le brunette 4x**10063**.

08

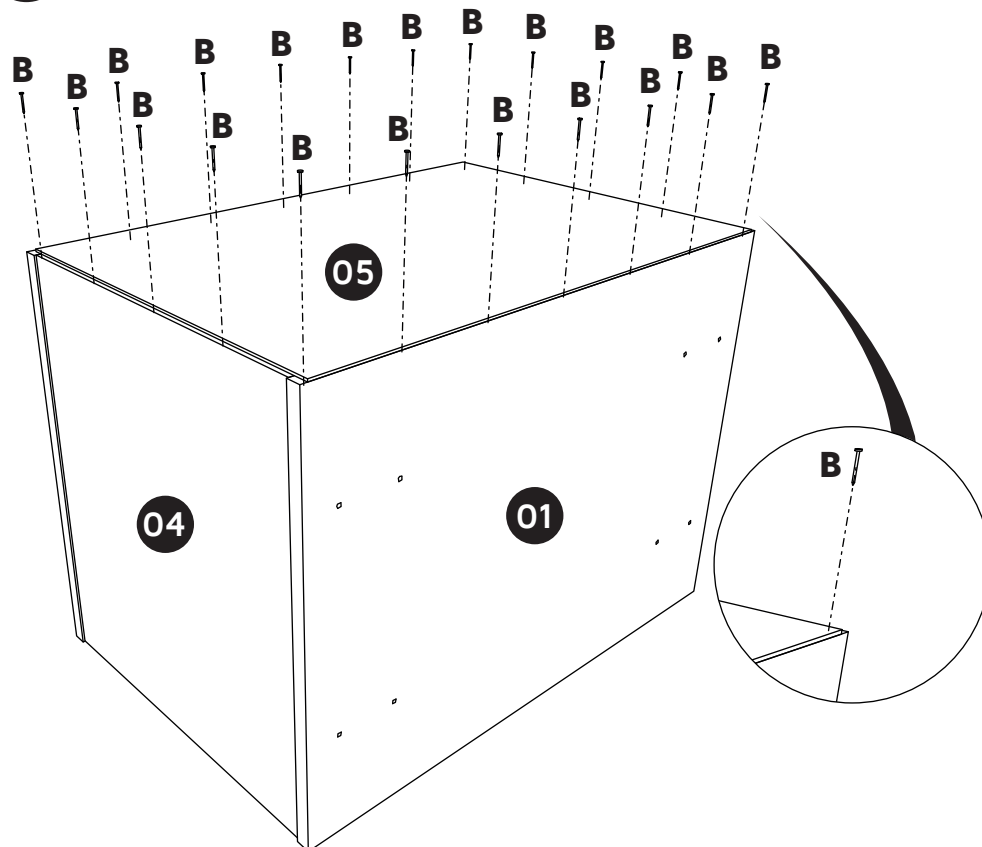

PASSO 08
Encaixar fundo **05** pregar **0357**.

STEP 08
Attach backplate **05** nailing **0357**.

PASO 08
Enganchar el fonfo **05** clavar **0357**.

ÉTAPE 08
Insérez le fond **05** Clouer **0357**.

09

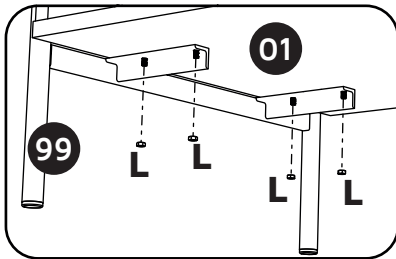
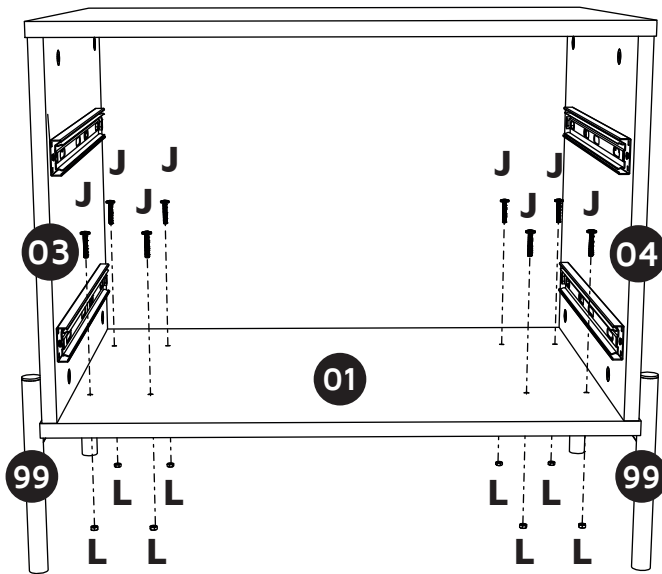
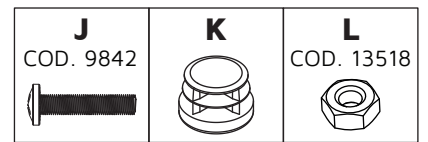

PASSO 09

Parafusar 4x**9842** base de aço **99**
na base **01** e rosquear as porcas 4x**13518**.

STEP 09

Screw 4x**9842** steel base **99** on
base **01** and thread the nuts 4x**13518**.

PASO 09

Atornillar 4x**9842** base de acero **99** en
la base **01** y rolar las tuercas 4x**13518**.

ÉTAPE 09

Vissez 4x**9842** base en acier **99** dans
la base **01** et fileter les écrous 4x**13518**.

10

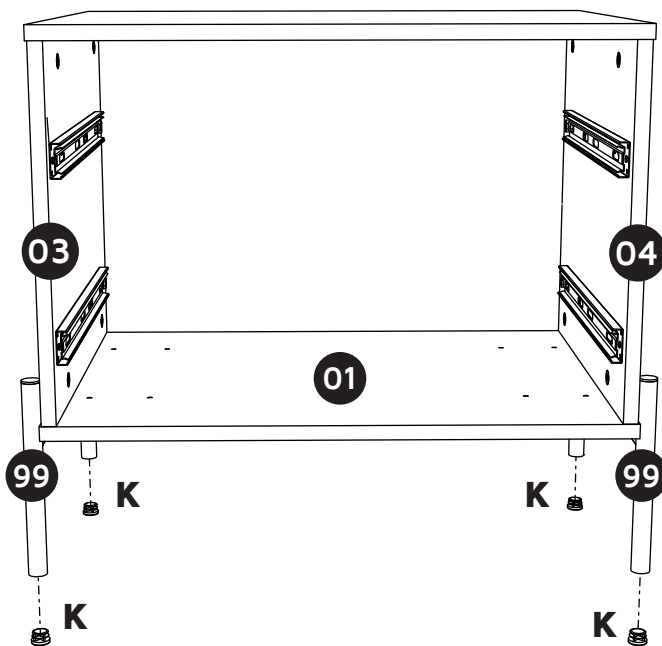

PASSO 10

Encaixar sapata plástica na base de aço **99**.

STEP 10

Insert plastic stopper on steel base **99**.



PASO 10

Enganchar almohadilla de plástico
en la base de acero **99**.

ÉTAPE 10

Insérez bouchon plastique dans base
en acier **99**.

11

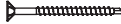
D	E	G	H
COD. 1668	COD. 2661	COD. 1533	COD. 0715
			

PASSO 11

Parafusar 4x**1533** as corredeiras 2x**2661** nas laterais gaveta esquerda e direita **61/62**.

PASO 11

Atornillar 4x**1533** las correderas 2x**2661** en los cajóns laterales izquierda y derecha **61/62**.

STEP 11

Screw 4x**1533** the slides 2x**2661** on the left and right drawer side **61/62**.

ÉTAPE 11

Vissez 4x**1533** les curseurs 2x**2661** sur les tiroir latéral gauche et droit **61/62**.

(2x)

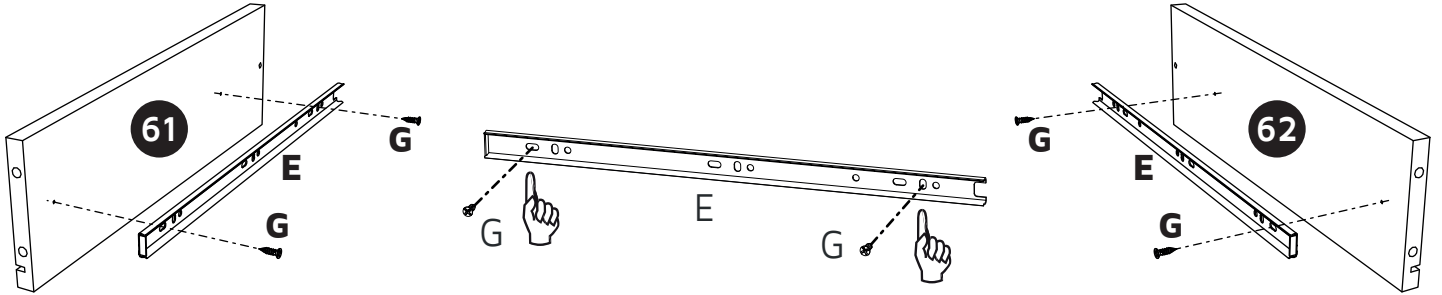

12

PASSO 12

Encaixar cavilhas 4x**1668** no contra fundo **66**. Encaixar laterais gaveta esquerda e direita **61/62** no contra fundo **66** e parafusar 2x**0715**.

PASO 12

Clavijas de ajuste 4x**1668** en cajón inferior **66**. Montar cajóns laterales izquierda y derecha **61/62** en lo cajón inferior **66** y atornillar 2x**0715**.

STEP 12

Insert dowels 4x**1668** on drawer back panel **66**. Attach left and right drawer side **61/62** on the drawer back panel **66** and screw 2x**0715**.

ÉTAPE 12

Insérez les chevilles 4x**1668** derrière **66**. Insérez tiroir latéral gauche et droit **61/62** dans derrière **66** et vissez 2x**0715**.

(2x)

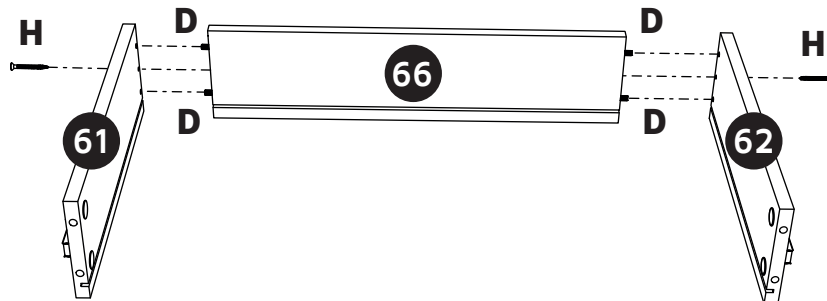

13

PASSO 13

Encaixar fundo gaveta **68**.

STEP 13

Attach drawer bottom **68**.

PASO 13

Montar fondo del cajón **68**.

ÉTAPE 13

Insérez fond de tiroir **68**.

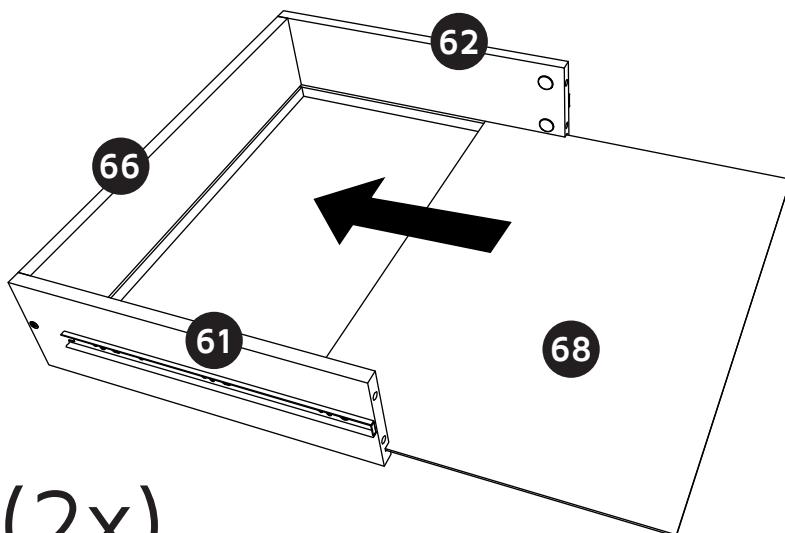

(2x)

14

PASSO 14

Parafusar minifix 4x**0599** na frente gaveta **67**. Encaixar frente gaveta **67**, parafusar castanhas 4x**10063** e colar **4** adesivos.

STEP 14

Screw minifix 4x**0599** on drawer front **67**. Attach drawer front **67**, screw nuts 4x**10063** and place **4** stickers.

PASO 14

Atornillar minifix 4x**0599** en la frente del cajón **67**. Montar frente del cajón **67**, atornillar las tuercas 4x**10063** y pegar **4** adhesivo.

ÉTAPE 14

Vissez minifix 4x**0599** dans façade de tiroir **67**. Insérez façade de tiroir **67**, vissez le brunette 4x**10063** et collez **4** l'adhésif.

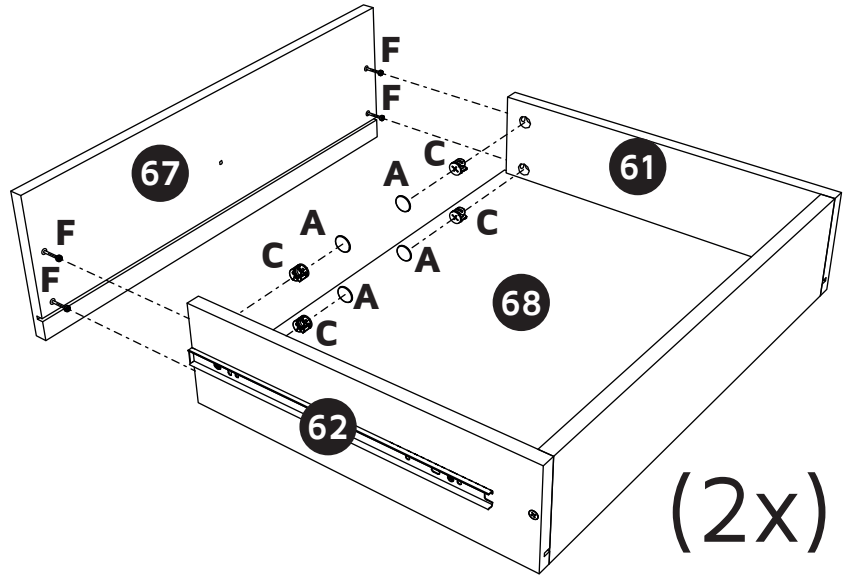
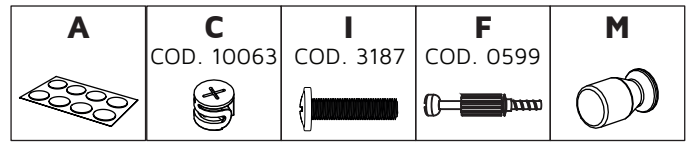

(2x)

15

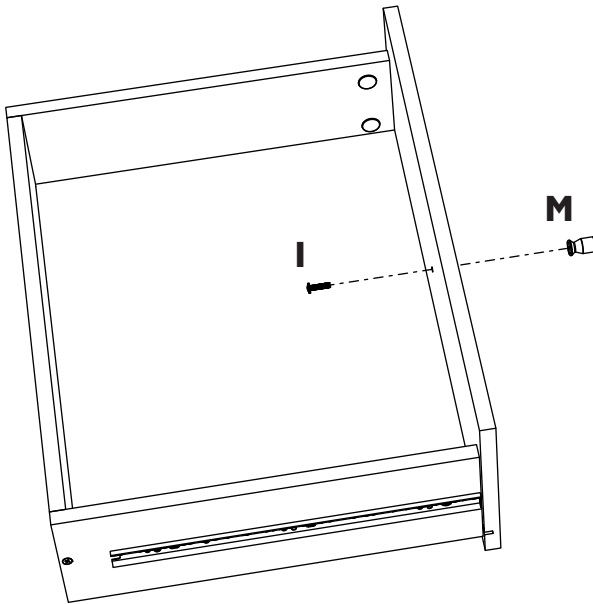

PASSO 15

Parafusar 1x**3187** o puxador.

STEP 15

Screw 1x**3187** the door handle.

PASO 15

Atornillar 1x**3187** el manija.

ÉTAPE 15

Vissez 1x**3187** et poignée.

(2x)

16

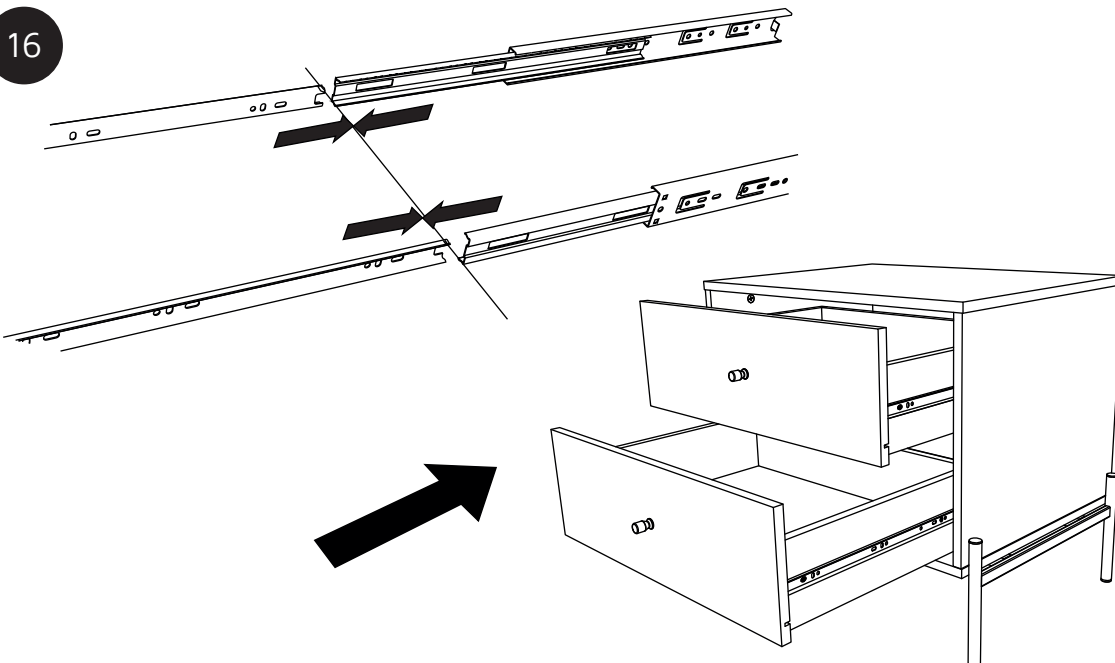

PASSO 16

Encaixar gavetas.

STEP 16

Attach drawers.

PASO 16

Montar cajones.

ÉTAPE 16

Insérez tiroirs.