

Main Features

- The control panel is positioned at the side of the machine and is provided with controls designed for ease of use
- The shafts rotate on ball bearings suitable for use under high-stress conditions
- The bowl protection guard complies with safety regulations. When lifted up, it activates a microswitch that automatically stops the machine.
- The unit rests on four rubber vibration mounts that guarantee stability and the reduction of noise levels.

Accessories included:

- Thin Wire Whisk
- Flat Beater
- Spiral



SPECIFICATIONS

Voltage	400Vac 3 50Hz
Power	5.5KW + 0.75KW
Speed	2 speeds 1° 28 (62) 2° 120 (265)
Maximum Current	-
Weight	575 kg
Plug Supplied	No
Bowl Lift	Automatic
Bowl Capacity	120 liters
Bowl Diameter	-
Humidity	Max 95%
Noise level	<70 decibel
Ambient Temp	Max 40°C
Warranty	4 Year Warranty (2 yr Labour 4 yr Parts)

OPTIONAL CONTROL -
Variable Speed Inverter - Single Phase Operation

STANDARD CONTROL -
3 speeds with 3 phase Motor.



DIMENSIONS

External Width	970 mm
External Depth	1150 mm
External Height	1960 mm

FRONT

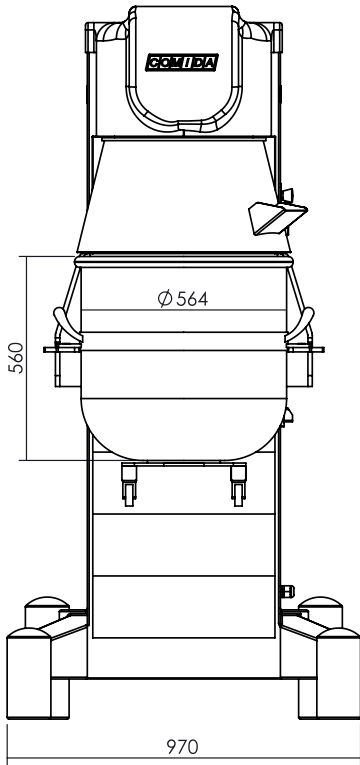

SIDE

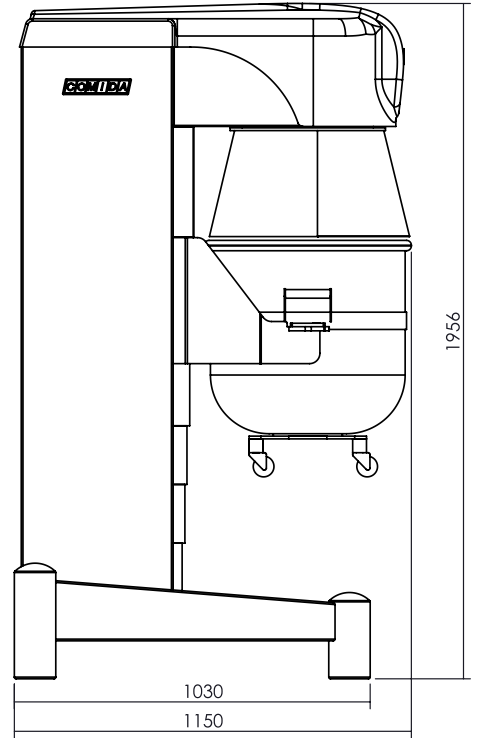

TOP

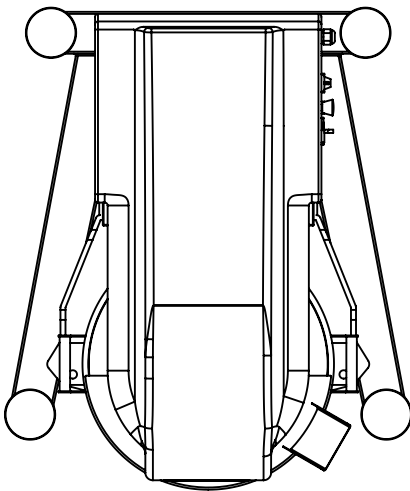

SIDE

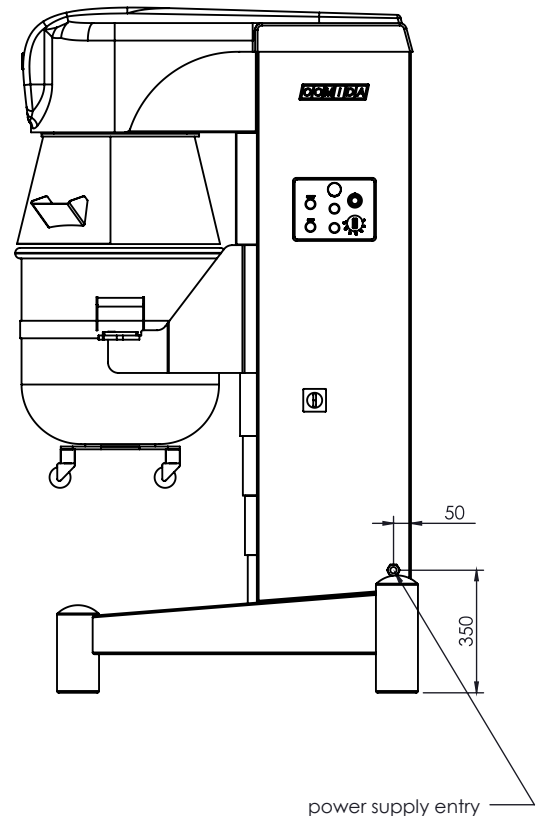

We reserve the right to alter specifications without notice.



Phone: 1800 183 818 Email: support@thegoodlady.com.au
Website: www.thegoodlady.com.au

SELENE 120 AUTO

PLANETARY MIXERS



PRODUCTIVITY CHART - Selene Mixers

Use of the tools	MAX		MEDIUM MINIMUM		MINIMUM		MAX MINIMUM		
Spatula Wooden spoon Whisk Hook/beater Screw/beater Dough hook Dough scraper Turnover	11 L	32 L	25 L	42 kg	32 kg	28 kg	22 kg	19 kg	48 kg
PL 120									

TOOL GUIDE - Selene Mixers

Standard equipment	Stainless steel bowl	Thin wire whisk	Flat beater	Kneading hook	Spiral	Thick wire whisk
PL 120	●	●	●		●	○

ACCESSORIES



THE
GOOD
LADY

Phone: 1800 183 818 Email: support@thegoodlady.com.au
 Website: www.thegoodlady.com.au