

# *Total Performance*

Yamaha Electric Guitars | Basses '88



*It could happen any time, anywhere.  
Under the bright lights on the arena  
stage, or under the ski poles in some-  
one's garage.*

*You're cruising along. Then the music  
takes over.*

*Without warning, you're into **Total  
Performance.***

*Electric guitars and basses are complex  
systems with a simple goal—to put you  
in touch with your music.*

*That same goal drives Yamaha  
designers and craftsmen to refine wood,  
pickups, hardware, every element of the  
instrument.*

*Play any Yamaha guitar: Feel the way  
each part works with all the rest. The  
way all of them work with you—to create  
**Total Performance.***





## RGX Series

Streamlined, aerodynamic, made to come alive in your hands.

The fast 24 $\frac{3}{4}$ " scale and wide 1 $\frac{3}{16}$ " radius fingerboard let you shape notes and chords with a personal touch. The unique height-adjustable locking nut gives you rock-solid tuning and a smooth action.

Play every one of the 24 jumbo frets. There's nothing to hold you back. Deep scalloped cutaways and body-hugging contours let you make the RGX a total extension of your musical impulses.

Climb high, dive deep and come back in tune. This is the ultimate expression of power guitar.

### RGX Active

Power Focus active pickups capture the total energy of your attack, the full resonance of the instrument. You get full power with less string pull and low noise. And high frequencies that carry through long cables and effects chains.

Advanced Drive Spectrum controls weave new colors into your sound. Every possible pickup combination, plus noise-free electronic coil-splitting. And overdrive boost for warmth and punch.

Raw power focused with electronic precision into lightning response. RGX Active.



### RGX 1212A

- Five-ply maple/mahogany neck
- 24 fret bound ebony fingerboard
- Power Focus active pickups
- Drive Spectrum control system
- RM Pro vibrato system with Pitch Rise adjustment
- Height-adjustable locking nut
- Select light alder body
- Heel-less neck through body construction
- Recessed input jack
- Fast-release strap security system

Pearl White

Gunmetal Blue



Metallic Black

Silver Pearl

**RGX 1220A**

- Five-ply maple/mahogany neck
- 24 fret bound ebony fingerboard
- Power Focus active pickups
- Drive Spectrum control system
- RM Pro vibrato system with Pitch Rise adjustment
- Height-adjustable locking nut
- Select light alder body
- Heel-less neck-through body construction
- Recessed input jack
- Fast-release strap security system

**RGX 603A**

- Satin finish maple neck
- 24 fret bound rosewood fingerboard
- Power Focus active pickups
- Drive Spectrum control system
- RM Pro vibrato system with Pitch Rise adjustment
- Height-adjustable locking nut
- Access Angle neck/body joint
- Basswood body
- Recessed input jack



Pearl White

Power Purple

**RGX 612A**

- Satin finish maple neck
- 24 fret bound rosewood fingerboard
- Power Focus active pickups
- Drive Spectrum control system
- RM Pro vibrato system with Pitch Rise adjustment
- Height-adjustable locking nut
- Access Angle neck/body joint
- Basswood body
- Recessed input jack



Candy Apple Red

Black Pearl

## RGX Series

Metallic Black

Silver Pearl

### RGX 1212S

- Five-ply maple/mahogany neck
- 24 fret bound ebony fingerboard
- Warm, powerful Alnico V pickups
- Tone Prism control system
- RIM Pro vibrato system with Pitch Rise adjustment
- Height-adjustable locking nut
- Select light alder body
- Heel-less neck through body construction
- Recessed input jack
- Fast-release strap security system

Pearl White

Metallic Black

### RGX 1203S

- Five-ply maple/mahogany neck
- 24 fret bound ebony fingerboard
- Crisp, detailed Alnico V pickups
- Tone Prism control system with coil tap
- RIM Pro vibrato system with Pitch Rise adjustment
- Height-adjustable locking nut
- Select light alder body
- Heel-less neck through body construction
- Recessed input jack
- Fast-release strap security system



Pearl White

#### **RGX 610M**

- Satin finish maple neck
- 24 fret maple fingerboard
- High output Alnico V humbucking pickup
- Direct Drive/Normal/Bright Rhythm toggle switch
- RM Pro vibrato system with Pitch Rise adjustment
- Height-adjustable locking nut
- Access Angle neck/body joint
- Basswood body
- Recessed input jack



Candy Apple Red

#### **RGX 603S**

- Satin finish maple neck
- 24 fret bound rosewood fingerboard
- Crisp, detailed Alnico V pickups
- 5-way selector switch
- RM Pro vibrato system with Pitch Rise adjustment
- Height-adjustable locking nut
- Access Angle neck/body joint
- Basswood body
- Recessed input jack



Pearl White

Black Pearl

#### **RGX 612S**

- Satin finish maple neck
- 24 fret bound rosewood fingerboard
- Crisp, powerful Alnico V pickups
- 5-way selector switch, coil splitter
- RM Pro vibrato system with Pitch Rise adjustment
- Height-adjustable locking nut
- Access Angle neck/body joint
- Basswood body
- Recessed input jack



Power Purple

#### **RGX 620S**

- Satin finish maple neck
- 24 fret bound rosewood fingerboard
- Powerful Alnico V pickups
- 3-way toggle pickup selector, coil splitter
- RM Pro vibrato system with Pitch Rise adjustment
- Height-adjustable locking nut
- Access Angle neck/body joint
- Basswood body
- Recessed input jack

## RGX/Series



### RGX 312

- Satin finish maple neck
- 24 fret wide radius fingerboard
- High output pickups
- 5-way selector switch, coil splitter
- Quick-reach master volume control
- Basswood body
- RMX II fine tuning vibrato



### RGX 211

- Satin finish maple neck
- 24 fret wide radius fingerboard
- High output pickups
- 3-way toggle pickup selector, coil splitter
- Quick-reach master volume control
- Basswood body
- RMX II fine tuning vibrato





Gold

Black

### **RGX 220**

- Satin finish maple neck
- 24 fret wide radius fingerboard
- High output pickups
- 3-way toggle pickup selector, coil splitter
- Quick-reach master volume control
- Basswood body
- RMX II fine tuning vibrato



White

Light Blue Metallic

### **RGX 112**

- Mahogany neck
- 24 fret wide radius fingerboard
- High output pickups
- 5-way selector switch
- Quick-reach master volume control
- Basswood body
- Vintage II vibrato



Power Purple

Red

### **RGX 110**

- Mahogany neck
- 24 fret fingerboard
- High output humbucker
- Quick-reach master volume control
- Basswood body
- Vintage II vibrato

**SE**

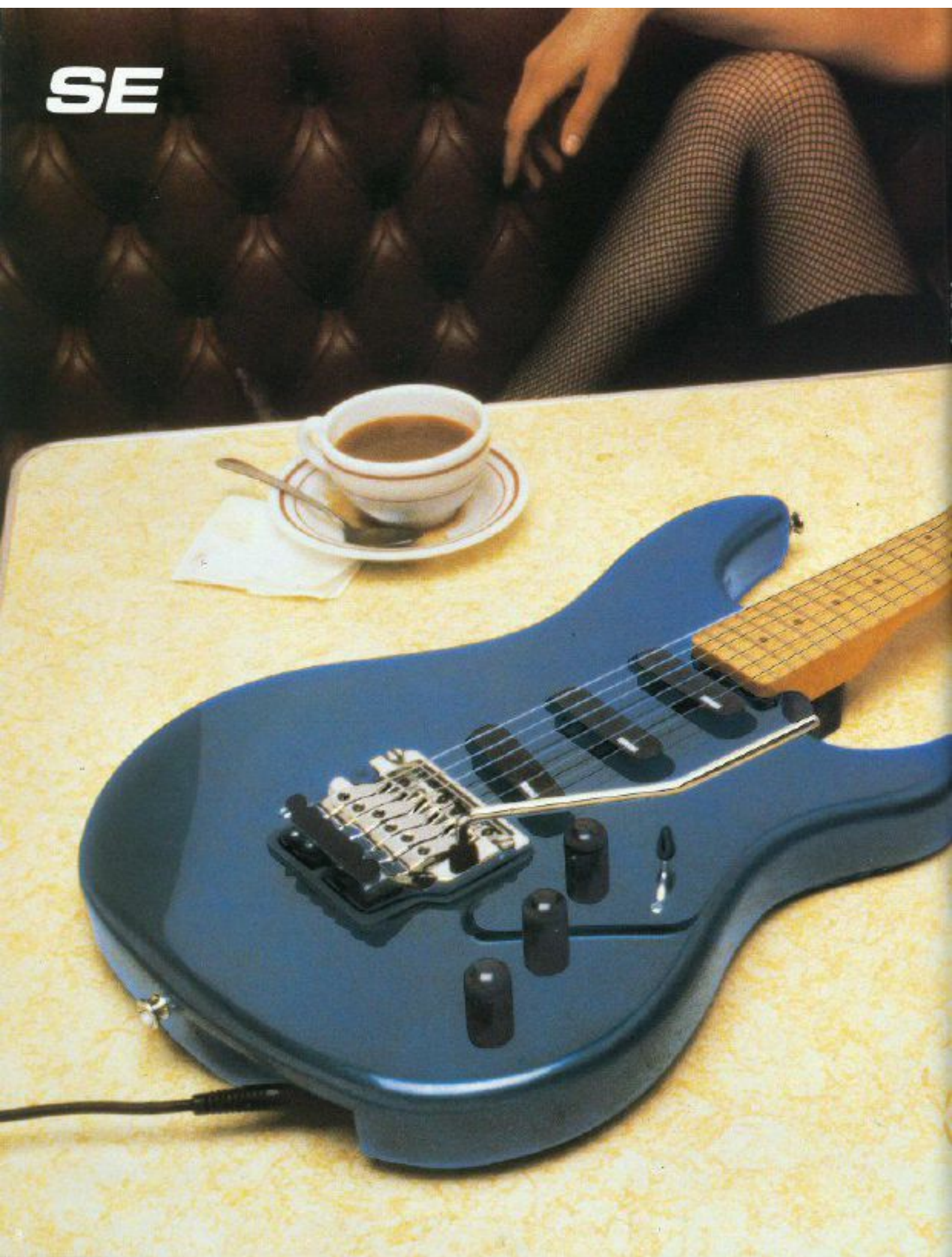



## SE Series

When the music's for real, your guitar has to respond with a voice as distinctive as your playing.

That's when the details become crucial. The body contours. The clarity, ringing harmonics and accurate intonation of the 25 1/2" scale. The wide radius fingerboard. The versatile pickups and advanced controls. The height-adjustable locking nut. The fine tuning vibrato systems that let you soar through space and land right on pitch.

Go ahead, raise your expectations. The new classics are here.

### SE Active

Advanced Yamaha technology takes the time-tested SE design to the limit—and beyond.

Power Focus active pickups bring new guts to humbucking power, without sustain-robbing

string pull. They push single-coil sting and snap through long cables and effects chains with clarity and detail. And without noise.

The Drive Spectrum control system opens new tonal combinations of bite, warmth and drive with mid boost and noise-free electronic coil-splitting.

SE Series guitars are quiet enough for the most critical situations. With reserve energy to push the music to new heights.



### SE 1212A

- Five-ply maple/mahogany neck
- 22 fret bound ebony fingerboard
- Power Focus active pickups
- Drive Spectrum control system
- RM Pro vibrato system with Pitch Rise adjustment
- Height-adjustable locking nut
- Select light/elder body
- Heel-less neck through body construction
- Reversed input jack
- Fast-release strap security system



### SE 1203A

- Five-ply maple/mahogany neck
- 22 fret bound ebony fingerboard
- Power Focus active pickups
- Drive Spectrum control system
- RM Pro vibrato system with Pitch Rise adjustment
- Height-adjustable locking nut
- Select light/elder body
- Heel-less neck through body construction
- Reversed input jack
- Fast-release strap security system



Candy Apple Red

Summertime Bronze

**SE 512A**

- Satin finish maple neck
- 22 fret rosewood fingerboard
- Power Focus active pickups
- Drive Spectrum control system
- RM Pro vibrato system with Pitch Rise adjustment
- Height-adjustable locking nut
- Access Angle neck/body joint
- Basswood body
- Recessed input jack

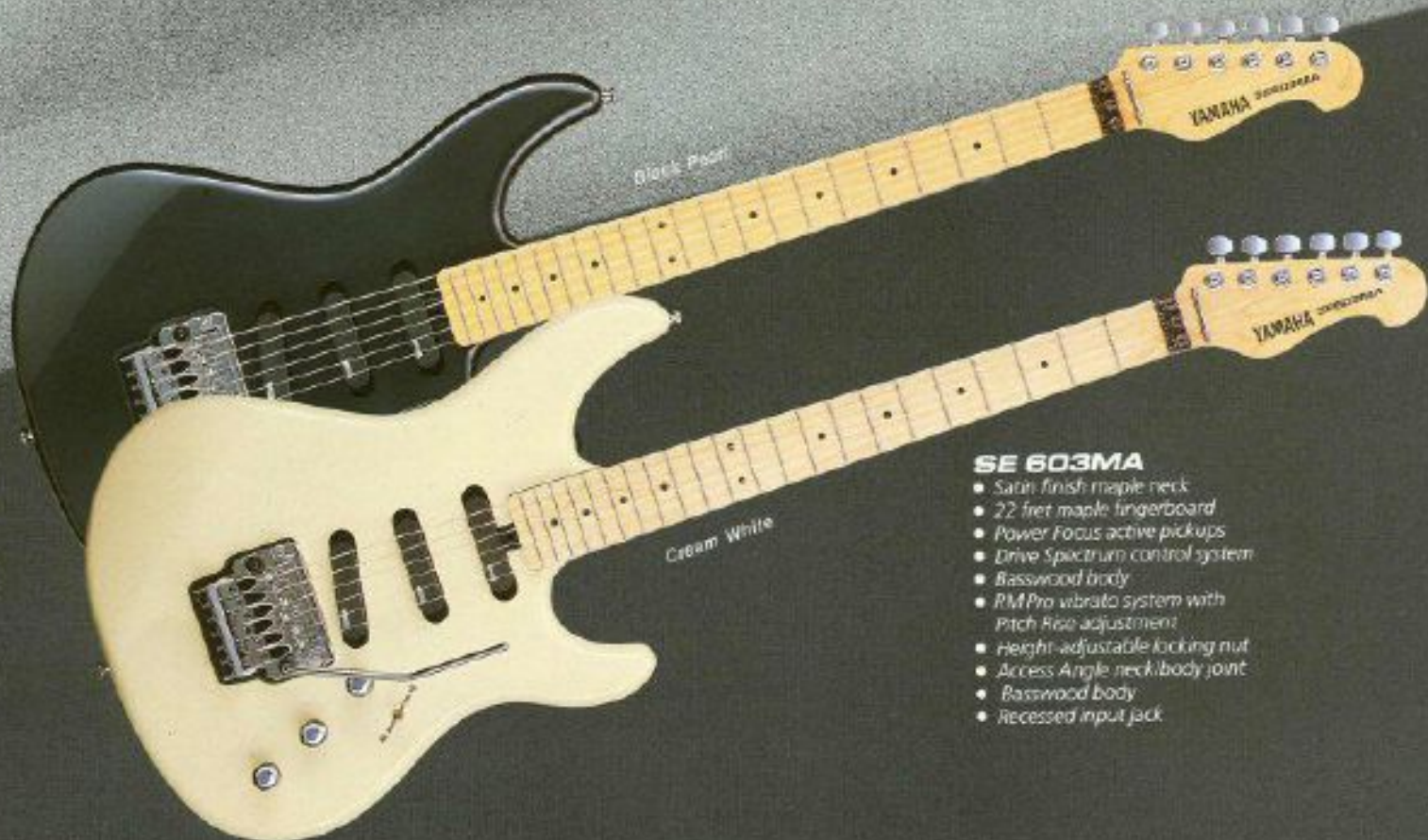

Black Pearl

Cream White

**SE 603MA**

- Satin finish maple neck
- 22 fret maple fingerboard
- Power Focus active pickups
- Drive Spectrum control system
- Basswood body
- RM Pro vibrato system with Pitch Rise adjustment
- Height-adjustable locking nut
- Access Angle neck/body joint
- Basswood body
- Recessed input jack

## SE Series

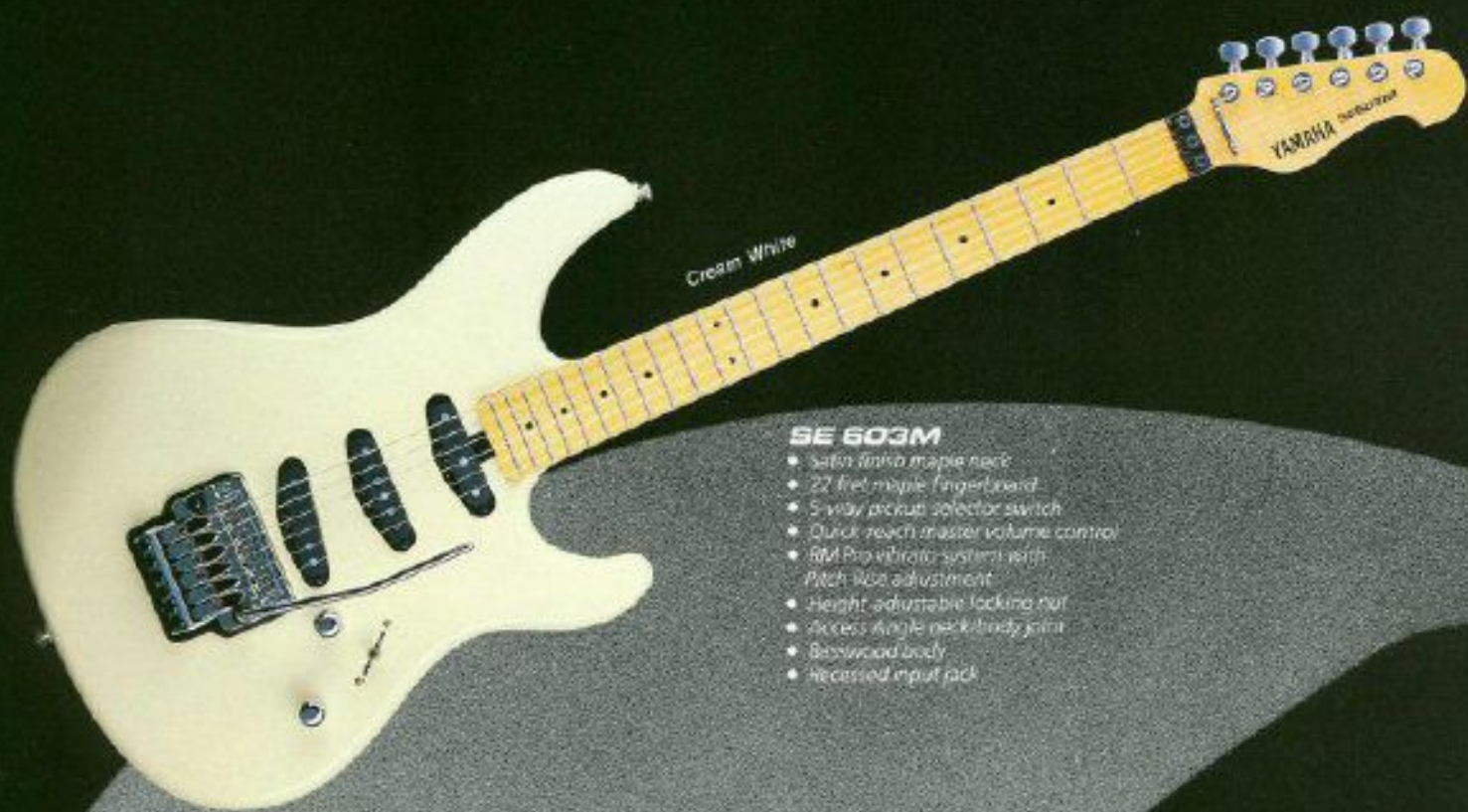

Cream White

### SE 603M

- Satin finish maple neck
- 22 fret maple fingerboard
- 5-way pickup selector switch
- Quick-reach master volume control
- RM Pro vibrato system with Pitch Rise adjustment
- Height-adjustable locking nut
- Access Angle neck/body joint
- Basswood body
- Recessed input jack

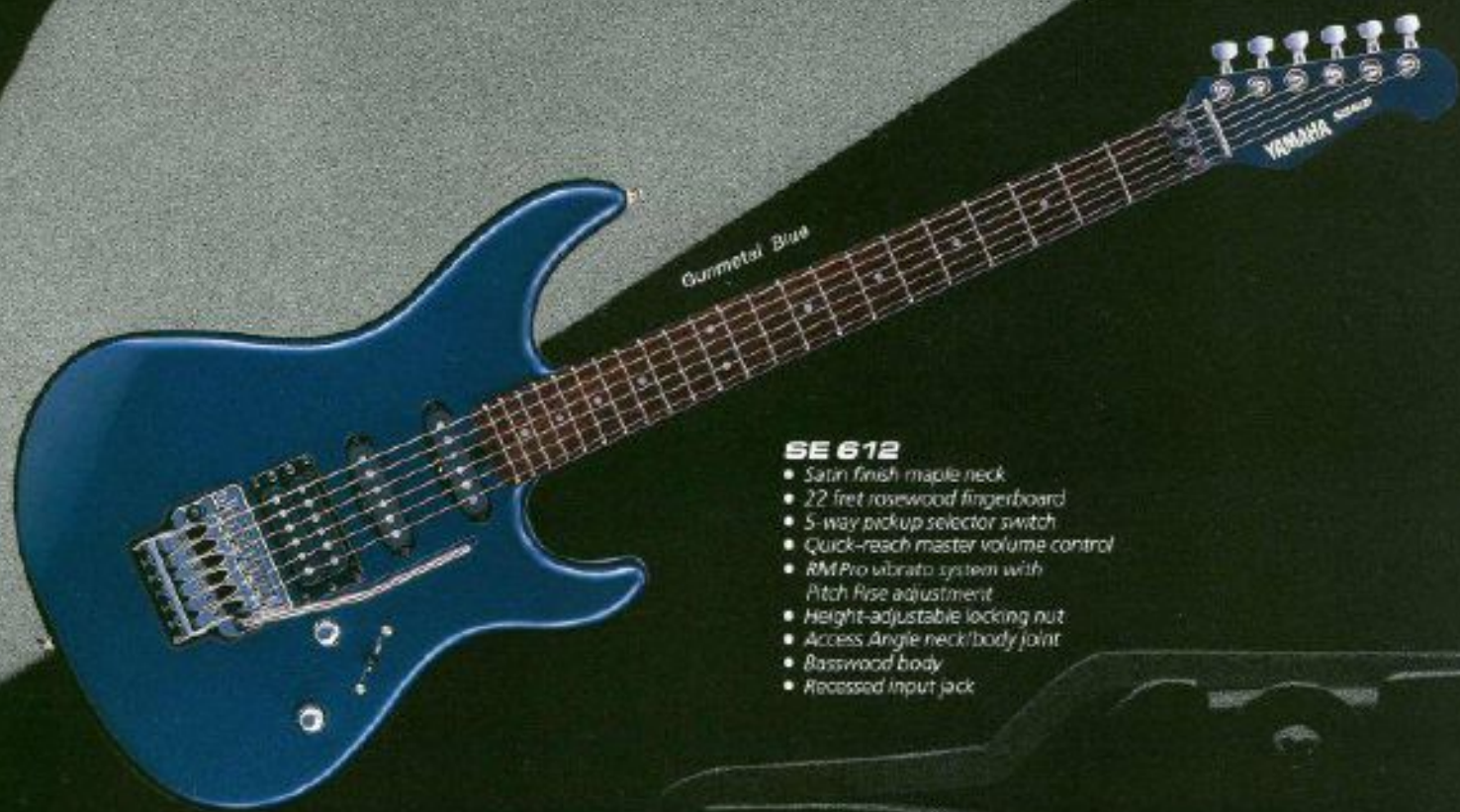

Gunmetal Blue

### SE 612

- Satin finish maple neck
- 22 fret rosewood fingerboard
- 5-way pickup selector switch
- Quick-reach master volume control
- RM Pro vibrato system with Pitch Rise adjustment
- Height-adjustable locking nut
- Access Angle neck/body joint
- Basswood body
- Recessed input jack



White

Gunmetal Blue

### SE 312M

- Satin finish maple neck
- 22 fret maple fingerboard
- 5-way pickup selector switch
- Quick-reach master volume control
- 3 ply pick-guard
- Basswood body
- RMX II fine tuning vibrato system



### SE 203M

- Satin finish maple neck
- 22 fret maple fingerboard
- 5-way pickup selector switch
- Quick-reach master volume control
- 3 ply pick-guard
- Basswood body
- Vintage II vibrato system



### SE 112

- Mahogany neck
- 22 fret wide radius fingerboard
- 5-way pickup selector switch
- Quick-reach master volume control
- 3 ply pick-guard
- Basswood body
- Vintage II vibrato system

Light Blue Metallic

Black

Silver Pearl

Red

## SA Series

*Responsive elegance, redefined with meticulous craftsmanship.*

*Semi-hollow beech/birch bodies with dove-tailed mahogany necks impart a rich, full tone to every note. Alder sustain blocks fight feedback at high volume. Traditional humbucking pickups capture all the warmth and presence of your playing.*

*SA Series: A new expression of tradition that lets you pull out the stops from rock to jazz.*

### SA 1100

- Mahogany set-in neck
- Semi-hollow beech/birch laminate body
- 22 fret bound rosewood fingerboard
- Warm, powerful humbucking pickups
- 3-way toggle pickup selector

### SA 2100

- Mahogany set-in neck
- Semi-hollow beech/birch laminate body
- 22 fret bound ebony fingerboard
- Warm, powerful humbucking pickups
- 3-way toggle pickup selector, coil splitters
- Gold plated hardware



Burgundy

Antique Sunburst



Brown Sunburst

Orange Sunburst

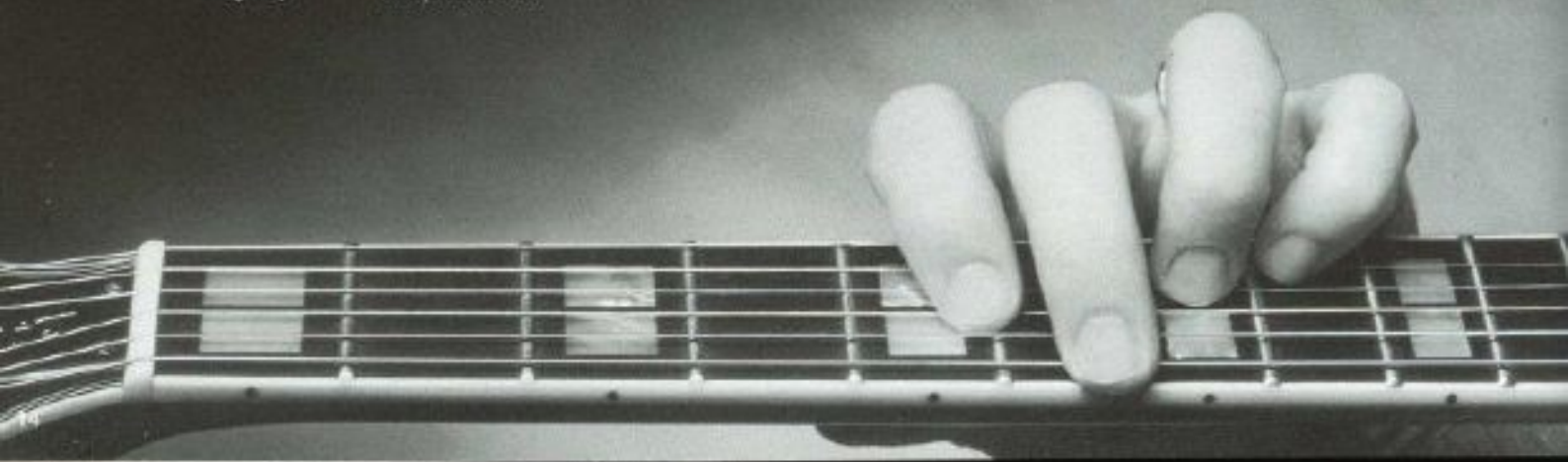



## AE 1200S

*It's the living heart of every guitar and bass—wood that is carefully selected and matched for tonal properties, then shaped and finished to Yamaha standards of quality and precision.*

*The sum of all our experience in wood and sound is the AE 1200S top, carved from a solid piece of select aged spruce.*

*The birch back and sides, dove-tailed maple neck and ebony fingerboard draw out its unique voice.*

*Alnico humbucking pickups radiate lush vintage tone. Coil splitters add new textural possibilities.*

*Tailor your sound with a warm carved Grenadilla wood bridge or the crisp definition of a gold-plated multi-vector adjustable metal bridge.*

*This harmonious combination of select materials is our most refined expression of the craft and art of luthiery.*



Natural

Antique Sunburst

## APX Series

They were contradictory goals: Acoustic warmth and expressiveness, electric power and versatility. Now Yamaha craftsmanship and APX technology bring them together.

The unique APX dual pickup system captures all the detail of the string attack and blends it with the rich resonance of the arched back body.

And spreads it across the soundstage in stereo on many APX guitars. With your choice of two modes. Plus continuous control over the position of each string.

Locking push-button controls keep your sound secure once you've set it. Thinner bodies resist feedback without sacrificing tone. Slim necks are contoured to your hand to make the transition from electric to acoustic effortless. Cutaways give you the freedom to reach for new ideas.

Cross over: Every APX guitar is a bridge from the guitar's roots to its future.

### APX 20

- Mahogany neck
- 24 fret bound ebony fingerboard
- 25 $\frac{1}{2}$ " scale
- Solid spruce top, scalloped bracing
- Sycamore back and sides
- Abalone body inlay
- Stereo 2-way FET/C pickup/pre-amp system
- Ebony bridge
- Push-button locking Volume, Treble, Bass and Mix controls
- Battery check LED

Cream White



© 2001 Yamaha Corporation

### APX 7

- Mahogany neck
- 24 fret bound rosewood fingerboard
- 25 $\frac{1}{2}$ " scale
- Spruce top, agathis back and sides
- 2 way FET pickup/pre-amp system
- Indian rosewood bridge
- Push-button locking Volume, Treble, Bass and Mix controls

### APX 10

- Mahogany neck
- 24 fret bound ebony fingerboard
- 25 $\frac{1}{2}$ " scale
- Spruce top, scalloped bracing
- Sycamore back and sides
- Stereo 2 way FET/IC pickup/pre-amp system
- Ebony bridge
- Push-button locking Volume, Treble, Bass and Mix controls
- Battery check LED

### APX 10T

- Mahogany neck
- 24 fret bound abony fingerboard
- 25 $\frac{1}{2}$ " scale
- Spruce top, scalloped bracing
- Rosewood back and sides
- Stereo 2 way FET/IC pickup/pre-amp system
- Ebony bridge
- Push-button locking Volume, Treble, Bass and Mix controls
- Battery check LED



Blue Burst

Black



Antique Stain Sunburst

Burgundy



Natural

# APX Series

## APX 9-12

- Mahogany neck
- 24 fret bound rosewood fingerboard
- 25 1/4" scale
- Spruce top, agathis back and sides
- Stereo 2 way FET/IC pickup/pre-amp system
- Indian rosewood bridge
- Push-button locking Volume, Treble, Bass and Mix controls
- Battery check LED



Light Brown Sunburst



Blue Burst

### **APX 6**

- Rosewood fingerboard
- 25 $\frac{1}{2}$ " scale
- Spruce top
- 2 way FET pickup/pre-amp system
- Indian rosewood bridge
- Push-button locking Volume, Treble and Bass and Mix controls



Cream White

### **APX 6N**

- Rosewood fingerboard
- 25 $\frac{1}{2}$ " scale
- Spruce top
- 2 way FET pickup/pre-amp system
- Indian rosewood bridge
- Push-button locking Volume, Treble, Bass and Mix controls



### **APX 10N**

- Ebony fingerboard
- 25 $\frac{1}{2}$ " scale
- Spruce top, Indian rosewood back and sides
- Stereo 2 way FET/IC pickup/pre-amp system
- Brazilian rosewood bridge
- Push-button locking Volume, Treble, Bass and Mix controls
- Battery check LED



## Advanced Form & Function

Function determines form. New ways of playing need new ways of looking at guitar design.

Total concentration. An attitude that makes every detail significant.

That's how we make our instruments respond to your musical impulses with an instinctively natural feel. That's why Yamaha guitars and basses have so many player-preferred features.

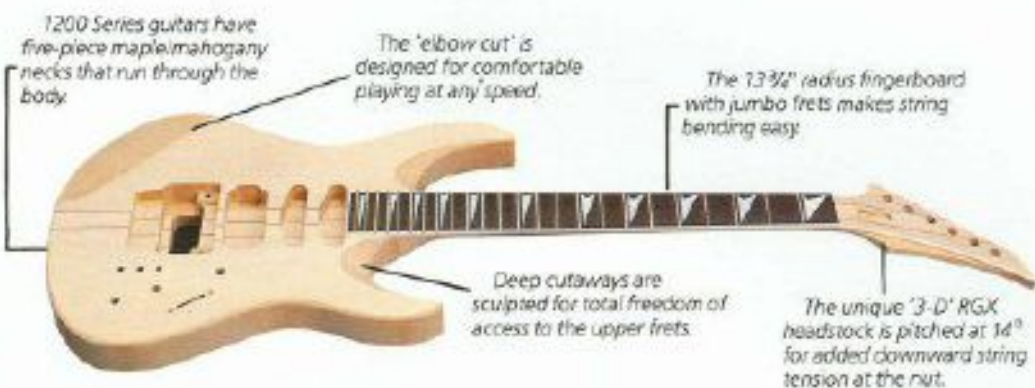

The RBX Access Angle neck/body joint uses six bolts for extra stability and sustain.



600 Series guitars have advanced bolt-on necks with Access Angle neck/body joints for unrestricted upper register playing.



1200 Series guitars feature a heel-less neck/body joint for easy upper register playing. Yamaha's locking strap system keeps 1200 Series instruments securely fastened.

### Pickups

Tone: Of course it's in the wood. But it's in the metal too.

Small differences in coil windings, magnets and pole pieces make big changes in your sound.

That's why we use advanced computer analysis and careful listening to make our pickups right for the instrument, the music, the player.

Each Yamaha pickup has a unique sound. A combination of Alnico or ceramic magnets, precisely controlled coil windings and carefully selected pole pieces that delivers the right balance of intensity and subtlety. From all-out power to sensitive timbral nuances, Yamaha pickups deliver.



When you want a warm, gutsy tone with plenty of definition and 'cut', Yamaha Alnico V or ceramic pickups deliver it. Three pickup guitars have the middle pickup wired out of phase to cut hum when two pickups are selected. Humbuckers are designed to match the output of single-coil pickups in coil-split mode.



Yamaha Power Focus active pickups have a wider tonal range that carries through long cables and effects chains without losing highs. There's plenty of reserve power for great sustain sounds, with minimal string pull. Advanced design with electronic coil-splitting means both single coil and 'humbucking' Active Series pickups are noise-free.



Yamaha Active Bass pickups update the 'classic' split and standard single coil configuration with noise-free low impedance designs. The wide frequency response gives you drive that supports the music, definition that helps you stand out.



The recessed input jack protects the vital connection between guitar and amp. Keeps the jack and cable out of sight for a sleek, modern look.

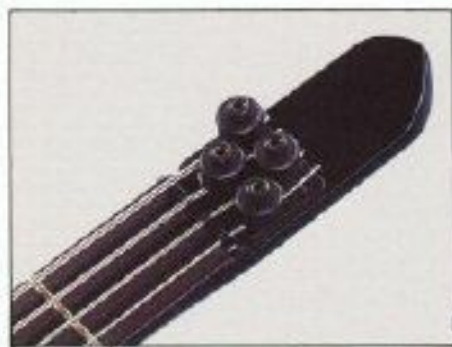

The BX headstock extends beyond the nut so your thumb can support first and second fret notes.

## Controls

This switch electronically simulates the sound of a single coil pickup, for biting rhythm tones using the bridge pickup alone or in combination.

Dial in up to 10 dB of boost between 500 Hz and 1 kHz with the Mid-boost control.

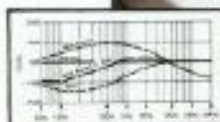

Each of these mini-toggle switches has a different function. The first bypasses the entire system to put you in Direct Drive.

On 1203 and 1212 guitars, the middle switch adds a capacitor, so the tone stays the same as you turn down the volume for crisp rhythm chops.

On 1203 guitars, the third switch taps the coils of the single pickups for a brighter sound. On 1212 guitars, it splits the coils of the bridge

humbucker (the output matches the other two pickups in split coil mode).

Quick-reach Master Volume lets you control loudness without breaking the rhythm of your leads.

Five position switches expand the versatility of three-pickup systems.

The Tone Prism system creates advanced tonal possibilities from conventional high output pickups. Three-pickup guitars have a Master Volume with one Tone control for the neck and middle pickups, another for the bridge. Two-pickup instruments have a Master Volume, a separate Volume control for the neck pickup plus a master Tone.

Quick-reach Master Volume control for swells, pedal-steel effects.

Spectrum Drive controls include individual mini-toggle switches for each pickup, so you can select any combination. The Master Tone control works no matter which pickups you choose.

RBX and BB active electronics enhance the tone of our specially developed low impedance bass pickups with 8dB of boost or cut centered at 30 Hz (Peak) and 10dB of boost or 12dB of cut centered at 5 KHz (Peak).



## Vibrato Systems

Because vibrato can be a dramatic creative tool, the advanced design RM Pro locking vibrato system is built for speed, comfort and

accuracy: faster string changing, precise intonation adjustment, ball bearing suspension and the versatility to bend up or down.

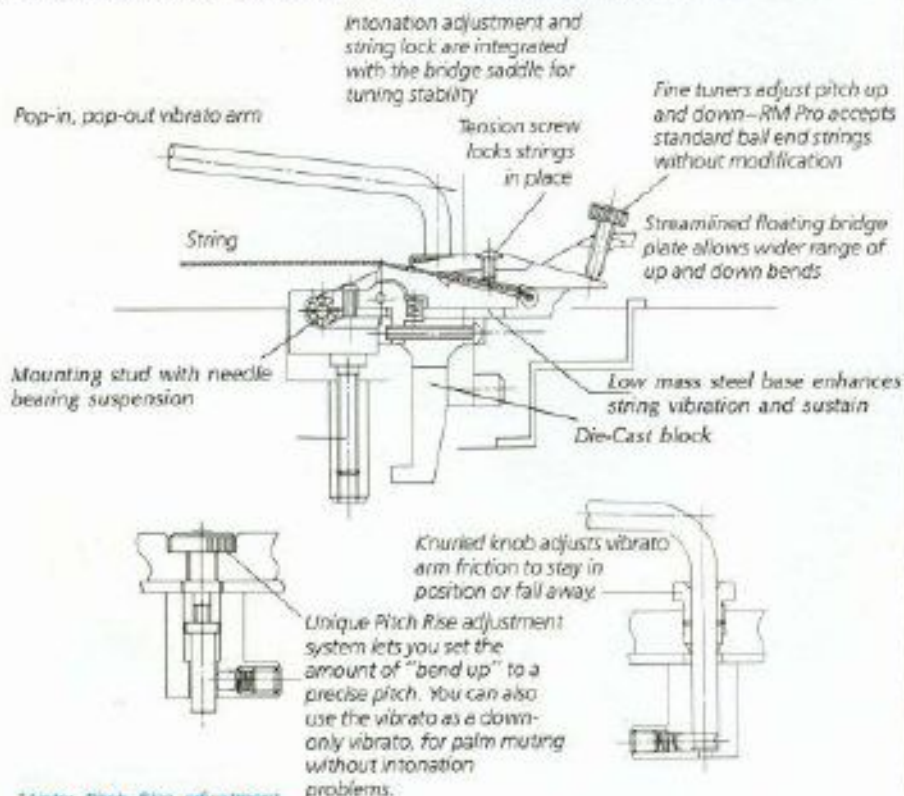

\*Note: Pitch Rise adjustment not provided on left-handed models.

## Hardware



The die-cast BX bridge has fine tuners for accurate pitch control. The quick-change string saddles accept any ball end strings.

Our locking nut mechanism is designed for speed, convenience and security. The height is adjustable at treble and bass ends. This unique Yamaha design gives you a low action at the bottom frets, plus rock-solid tuning stability.



You wouldn't let anyone else tune your guitar. We won't let anyone else make our tuners. Yamaha tuners are precision-engineered for the utmost in accuracy, stability and durability. Nothing less would be good enough for us. Or for you.



**RBX**







## RBX Series

To put modern music in motion, you need streamlined comfort, effortless balance, penetrating tone.

A light, naturally balanced body with deep contoured cutaways. A massive die-cast bridge for sustain and punch. "Access Angle" bolt-on construction to let you use the full range. Maple neck and rosewood fingerboard for a crisp sound with depth and power. A classic pickup combination updated with a hum-bucking split single coil and a standard single coil pickup.

That's RBX: Rock solid, instantly responsive, designed to make the bass a total extension of your musical personality.

### RBX Active

Active electronics with two bands of boost or cut equalization.

Shape your sound for extreme power, pop-out presence, or the perfect balance of driving fundamentals and delicate overtones.

Active pickups in a time-tested configuration give you the right raw material to work with—a solid sound with strong character.



Custom Blue  
Translucent



Black

### RBX 800A

- 31.78" scale
- Maple neck
- 24 fret rosewood fingerboard
- Power Focus active pickups
- Die-cast dx bridge
- Extended Access Angle neck/body joint
- Active Four control system



**RBX 5**

- 33 7/8" scale
- Satin finish maple neck
- 22 fret rosewood fingerboard
- Split and standard single coil pickups
- Low-mass bridge
- Access Angle neck/body joint
- Mix control balances front and rear pickups

Custom Blue  
Translucent

Pearl White

Pearl White

Custom Red  
Translucent

**RBX 800AF**

- 33 7/8" scale
- Maple neck
- Fretless rosewood fingerboard
- Power Focus active pickups
- Die-cast/Al bridge
- Extended Access Angle neck/body joint
- Active Four control system

## RBX Series



### RBX 550

- 33 7/8" scale
- Satin finish maple neck
- 22 fret rosewood fingerboard
- Alnico split and standard single coil pickups
- Die-cast bridge
- Access Angle neck/body joint
- Mix control balances front and rear pickups

### RBX 300

- 33 7/8" scale
- Maple neck
- 22 fret rosewood fingerboard
- Split single coil pickup
- Die-cast bridge



White

Black



Black

Red

### **RBX 200**

- 33 7/8" scale
- Maple neck
- 22 fret rosewood fingerboard
- Split single coil pickup
- Low-mass bridge



Red

Black

### **RBX 200F**

- 33 7/8" scale
- Maple neck
- Fretless rosewood fingerboard
- Split single coil pickup
- Low-mass bridge

## BB Series

Warmth and presence. Tonal shading. Fluid expression. Consistent response. Bodies and necks contoured for comfort, with deep cutaways for upper octave playing. Low-mass bridges and classic pickup configurations let the radiant warmth of select woods shine through every note.

The classic expression of bass performance.

### BB Active

How do you improve a classic? You give it active electronics with wide-ranging, noise-free pickups that bring out a rich tonal spectrum with driving presence. Plus two bands of equalization to shape the sound to your music.

Now more than ever, BB basses are the standard of comparison.

### BB 3000A

- Alder body
- Maple/mahogany neck
- Neck-through body construction
- 21 fret ebony fingerboard
- Power Focus active pickups
- Active Four control system
- Die-cast die bridge
- Gold-plated hardware



Candy Apple Red Metallic Black

### BB 5000A

- Alder body
- Maple/mahogany neck
- Neck-through body construction
- 24 fret ebony fingerboard
- Power Focus active pickups
- Active Four control system
- Low-mass bridge
- Gold-plated hardware



Silver Pearl Black



Pearl White Black

### BB 3000AF

- Alder body
- Maple/mahogany neck
- Neck-through body construction
- Fretless ebony fingerboard
- Power Focus active pickups
- Active Four control system
- Brass nut
- Gold-plated hardware

**BB 1600**

- Select light alder body
- Maple neck
- 21 fret rosewood fingerboard
- Split and bar magnet single coil pickups
- Die-cast/dx bridge

**BB 450**

- Select light alder body
- rosewood neck
- 21 fret rosewood fingerboard
- Split and standard single coil pickups
- Die-cast/std bridge

*Gunmetal Blue**Candy Apple Red***BB 350F**

- Maple neck
- Fretless rosewood fingerboard with maple position inlays
- Split and standard single coil pickups
- Low-mass bridge

*Black***BB 300**

- Maple neck
- 21 fret rosewood fingerboard
- Split single coil pickup
- Die-cast/std bridge

*Candy Apple Red*

## BX Series

Headless designs refined for comfort and playability.

The neck extends past the nut for thumb support when fingering low notes. This string lock and fine tuning bridge work with any ball-end strings you choose. The five-ply maple/mahogany neck extends through the sculptured body. The ebony fingerboard has a crisp, even response over all 24 frets. High output humbuckers give you a powerfully centered sound to drive the music.



Black

### BX 1

- Maple/mahogany neck
- 24 fret ebony fingerboard
- Fine tuning bridge
- Headless design
- High output humbucking pickups
- Coil splitter
- Individual volume and Master tone controls



Black

### BX 5

- Maple/mahogany neck
- 24 fret ebony fingerboard
- Fine tuning five string bridge
- Headless design
- High output humbucking pickups
- Coil splitter
- Individual volume and Master tone controls

## MB Series

When your music is moving in dynamic directions, you're looking for original sounds and fast moves.

When a fast, responsive medium-scale double octave bass speaks with the clarity and propulsive power of a long-scale instrument, you've found what you need.

It's all there, in the precisely balanced, anatomically contoured body of the Motion Bass.



Candy Apple Red

### MB II

- Agathis body
- Maple neck
- 32 3/8" scale
- 24 fret rosewood fingerboard
- 16 pole humbucking pickups
- Fine tuning bridge
- Gold plated hardware
- Individual volume and Master tone controls



Power Purple

### MB III

- Basswood body
- Maple neck
- 32 3/8" scale
- 24 fret rosewood fingerboard
- 16 pole humbucking pickups
- Die-cast bridge
- Chrome plated hardware
- Individual volume and Master tone controls



## Left-handed Guitars & Basses

You shouldn't have to settle for an instrument that's not right, just because you play left-handed. Whatever your level of ability, whatever your budget, you can find a real Yamaha guitar or bass made for you.

### RGX 312L

- Satin finish maple neck
- 24 fret wide radius fingerboard
- High output pickups
- 5-way selector switch, coil splitter
- Quick-reach master volume control
- Basswood body
- RMX II fine tuning vibrato



### SE 612L

- Satin finish maple neck
- 22 fret rosewood fingerboard
- 5-way pickup selector switch
- Quick-reach master volume control
- RM Pro vibrato system
- Access Angle neck/body joint
- Basswood body
- Recessed input jack



### BB 1600L

- Select lighter alder body
- Maple neck
- 21 fret rosewood fingerboard
- Split humbucker plus bar magnet single coil pickups
- Die-cast bridge



### BB 300L

- Maple neck
- 21 fret rosewood fingerboard
- Split single coil pickup
- Die-cast bridge

# Specifications

Model	RGX 1220A	RGX 1212A	RGX 6034	RGX 6124	RGX 1212S	RGX 1203S	RGX 610M	RGX 603S	RGX 612S*
Neck	Maple/Mahogany	Maple/Mahogany	Satin Finish Maple	Satin Finish Maple	Maple/Mahogany	Maple/Mahogany	Satin Finish Maple	Satin Finish Maple	Satin Finish Maple
Fingerboard	Bound Ebony	Bound Ebony	Bound Rosewood	Bound Rosewood	Bound Ebony	Bound Ebony	Maple	Bound Rosewood	Bound Rosewood
Neck Width	1 11/16" (43 mm)	1 11/16" (43 mm)	1 11/16" (43 mm)	1 11/16" (43 mm)	1 11/16" (43 mm)	1 11/16" (43 mm)	1 11/16" (43 mm)	1 11/16" (43 mm)	1 11/16" (43 mm)
Radius	13 3/4" (350 mm)	13 3/4" (350 mm)	13 3/4" (350 mm)	13 3/4" (350 mm)	13 3/4" (350 mm)	13 3/4" (350 mm)	13 3/4" (350 mm)	13 3/4" (350 mm)	13 3/4" (350 mm)
Scale Length	24 3/4" (628 mm)	24 3/4" (628 mm)	24 3/4" (628 mm)	24 3/4" (628 mm)	24 3/4" (628 mm)	24 3/4" (628 mm)	24 3/4" (628 mm)	24 3/4" (628 mm)	24 3/4" (628 mm)
Frets	24	24	24	24	24	24	24	24	24
Body	Select Light Alder	Select Light Alder	Basswood	Basswood	Select Light Alder	Select Light Alder	Basswood	Basswood	Basswood
Colors	Metallic Black Pearl White Silver Pearl Carmetal Blue	Metallic Black Pearl White Silver Pearl Carmetal Blue	Black Pearl Pearl White Candy Apple Red Power Purple	Black Pearl Pearl White Candy Apple Red Power Purple	Metallic Black Pearl White Silver Pearl Carmetal Blue	Metallic Black Pearl White Silver Pearl Carmetal Blue	Pearl White Metallic Black	Black Pearl Pearl White Candy Apple Red Power Purple	Black Pearl Pearl White Candy Apple Red Power Purple
Construction	Neck-thru-body	Neck-thru-body	Access Angle	Access Angle	Neck-thru-body	Neck-thru-body	Access Angle	Access Angle	Access Angle
Vibrato System	Black Chrome RM Pro	Black Chrome RM Pro	Black Chrome RM Pro	Black Chrome RM Pro	Black Chrome RM Pro	Black Chrome RM Pro	Black Chrome RM Pro	Black Chrome RM Pro	Black Chrome RM Pro
Pickups	Power Focus: 2 Humbucking	Power Focus: 2 Single Coil, 1 Humbucking	Power Focus: 3 Single Coil	Power Focus: 2 Single Coil, 1 Humbucking	Alnico V: 2 Single Coil, 1 Humbucking	Alnico V: 3 Single Coil	Alnico V: 1 High Output	Alnico V: 3 Single Coil	Alnico V: 2 Single Coil, 1 Humbucking
Pickup Switch	3 Position	3 Mini-toggles	3 Mini-toggles	3 Mini-toggles	5 Position	5 Position	None	5 Position	5 Position
Controls	Master Volume, Front Volume Tone	Master Volume, Mid Boost, Tone	Master Volume, Mid Boost, Tone	Master Volume, Mid Boost, Tone	Master Volume, Front/Center Tone, Rear Tone, 3 mini function sw	Master Volume, Front/Center Tone, Rear Tone, 3 mini function sw	Master Volume, 3 Position Mini-toggle	Master Volume, Front/Center Tone, Rear Tone	Master Volume, Front/Center Tone, Rear Tone
Coil Tap/Split	Split	Split	None	Split	Split	Tap	None	None	Split

Model	SE 1203A	SE 1212A	SE 603M4	SE 612A	SE 603M	SE 612 *	SE 312M	SE 203M *	SE 112
Neck	Maple/Mahogany	Maple/Mahogany	Satin Finish Maple	Satin Finish Maple	Satin Finish Maple	Satin Finish Maple	Satin Finish Maple	Satin Finish Maple	Mahogany
Fingerboard	Bound Ebony	Bound Ebony	Maple	Rosewood	Maple	Rosewood	Maple	Maple	Bubinga
Neck Width	1 5/8" (41 mm)	1 5/8" (41 mm)	1 5/8" (41 mm)	1 5/8" (41 mm)	1 5/8" (41 mm)	1 5/8" (41 mm)	1 5/8" (41 mm)	1 5/8" (41 mm)	1 5/8" (41 mm)
Radius	13 3/4" (350 mm)	13 3/4" (350 mm)	13 3/4" (350 mm)	13 3/4" (350 mm)	13 3/4" (350 mm)	13 3/4" (350 mm)	13 3/4" (350 mm)	13 3/4" (350 mm)	13 3/4" (350 mm)
Scale Length	25 1/2" (648 mm)	25 1/2" (648 mm)	25 1/2" (648 mm)	25 1/2" (648 mm)	25 1/2" (648 mm)	25 1/2" (648 mm)	25 1/2" (648 mm)	25 1/2" (648 mm)	25 1/2" (648 mm)
Frets	22	22	22	22	22	22	22	22	22
Body	Select Light Alder	Select Light Alder	Basswood	Basswood	Basswood	Basswood	Basswood	Basswood	Basswood
Colors	Metallic Black Cream White Silver Pearl Candy Apple Red	Metallic Black Cream White Silver Pearl Candy Apple Red	Black Pearl Cream White Carmetal Blue Candy Apple Red	Black Pearl Cream White Carmetal Blue Candy Apple Red	Black Pearl Cream White Carmetal Blue Candy Apple Red	Black Pearl Cream White Carmetal Blue Candy Apple Red	Black White Gun Metal Blue Red	Black White Light Blue Metallic Red	Black White Solar Pearl Red
Construction	Neck-thru-body	Neck-thru-body	Access Angle	Access Angle	Access Angle	Access Angle	Access Angle-II	Access Angle-II	Access Angle-II
Vibrato System	Gold RM Pro	Gold RM Pro	Chrome RM Pro	Chrome RM Pro	Chrome RM Pro	Chrome RM Pro	Chrome RMX II	Chrome Vintage II	Chrome Vintage II
Pickups	Power Focus: 3 Single Coil	Power Focus: 2 Single Coil, 1 Humbucking	Power Focus: 3 Single Coil	Power Focus: 2 Single Coil, 1 Humbucking	Alnico V: 3 Single Coil	Alnico V: 2 Single Coil, 1 Humbucking	2 Single Coil 1 Humbucking	3 Single Coil	1 Humbucking, 2 Single Coil
Pickup Switch	5 Position	5 Position	5 Position	5 Position	5 Position	5 Position	5 Position	5 Position	5 Position
Controls	Master Volume, Mid Boost, Tone	Master Volume, Mid Boost, Tone	Master Volume, Mid Boost, Tone	Master Volume, Mid Boost, Tone	Master Volume, Master Tone	Master Volume, Master Tone	Master Volume, Master Tone	Master Volume, Master Tone	Master Volume, Master Tone
Coil Tap/Split	None	Split	None	Split	None	Split	Split	None	None

Model	RBX 800A	RBX 800AF	RBX 5	RBX 550	RBX 300	RBX 200	BB 3000A	BB 3000A	BB 3000AF
Neck	Maple	Maple	Satin Finish Maple	Satin Finish Maple	Satin Finish Maple	Maple	Maple/Mahogany	Maple/Mahogany	Maple/Mahogany
Fingerboard	Rosewood	Rosewood	Rosewood	Rosewood	Rosewood	Rosewood	Ebony	Ebony	Ebony
Neck Width	1 5/8" (40 mm)	1 5/8" (40 mm)	1 11/16" (43 mm)	1 5/8" (40 mm)	1 5/8" (40 mm)	1 5/8" (40 mm)	1 11/16" (43 mm)	1 5/8" (40 mm)	1 5/8" (40 mm)
Radius	10" (250 mm)	10" (250 mm)	10" (250 mm)	10" (250 mm)	10" (250 mm)	10" (250 mm)	10" (250 mm)	10" (250 mm)	10" (250 mm)
Scale Length	33 7/8" (860 mm)	33 7/8" (860 mm)	33 7/8" (860 mm)	33 7/8" (860 mm)	33 7/8" (860 mm)	33 7/8" (860 mm)	33 7/8" (860 mm)	33 7/8" (860 mm)	33 7/8" (860 mm)
Frets	24	None	22	22	22	22	24	27	None
Body	Alder/Lak*	Alder/Lak*	Basswood/Pal*	Basswood	Basswood	Basswood	Alder	Alder	Alder
Colors	Custom Red Translucent Custom Blue Translucent Black Pearl White	Custom Red Translucent Custom Blue Translucent Black Pearl White	Custom Red Translucent Black Pearl White	Candy Apple Red Pearl White	Black White	Black Red	Black Cream White Silver Pearl	Metallic Black Cream White Candy Apple Red	Black Cream White Candy Apple Red Natural
Construction	Deep Access Angle	Deep Access Angle	Access Angle	Access Angle	Access Angle-II	Access Angle-II	Neck-thru-body	Neck-thru-body	Neck-thru-body
Bridge	Die-cast/DX	Die-cast/DX	5 String	Die-cast/DX	Die-cast/DX	Low Mass	5 String Low Mass	Die-cast/DX	Die-cast/DX
Pickups	Power Focus Split Single Coil, Standard Single Coil	Power Focus Split Single Coil, Standard Single Coil	Split Single Coil, Standard Single Coil	Split Single Coil, Standard Single Coil	Split Single Coil	Split Single Coil	Power Focus Split Single Coil, Standard Single Coil	Power Focus Split Single Coil, Standard Single Coil	Split Single Coil, Standard Single Coil
Controls	Volume, Mix, Bass, Treble	Volume, Mix, Bass, Treble	Volume, Mix Tone	Volume, Mix Tone	Volume, Tone	Volume, Tone	Volume, Mix Bass, Treble	Volume, Mix Bass, Treble	Volume, Mix Bass, Treble

\* With Custom Translucent finishes

RGX 620S	RGX 312 <sup>1</sup>	RGX 220	RGX 211	RGX 110	RGX 112	SA 2100	SA 1100	AE 1200S
Satin Finish Maple	Satin Finish Maple	Satin Finish Maple	Satin Finish Maple	Mahogany	Mahogany	Mahogany	Mahogany	Mahogany
Bound Rosewood	Bubinga	Bubinga	Bubinga	Bubinga	Bubinga	Bound Ebony	Bound Rosewood	Bound Ebony
1 7/16" (43 mm)	1 7/16" (43 mm)	1 7/16" (43 mm)	1 7/16" (43 mm)	1 7/16" (43 mm)	1 7/16" (43 mm)	1 7/16" (43 mm)	1 7/16" (43 mm)	1 15/16" (45 mm)
13 3/4" (350 mm)	13 3/4" (350 mm)	13 3/4" (350 mm)	13 3/4" (350 mm)	13 3/4" (350 mm)	13 3/4" (350 mm)	13 3/4" (350 mm)	13 3/4" (350 mm)	13 3/4" (350 mm)
24 3/4" (628 mm)	24 3/4" (628 mm)	24 3/4" (628 mm)	24 3/4" (628 mm)	24 3/4" (628 mm)	24 3/4" (628 mm)	24 3/4" (628 mm)	24 3/4" (628 mm)	25 3/16" (646 mm)
24	24	24	24	24	24	22	22	20
Basswood	Basswood	Basswood	Basswood	Basswood	Basswood	Beech/Birch Semi-bulkow	Beech/Birch Semi-bulkow	Spruce Top Birch/Beech Rock/Slopes
Black Pearl Red White Candy Apple Red Power Purple	Black White Red Silver Pearl	Black White Red Gold	Black White Red Carmel Blue	Black White Red Power Purple	Black White Red Light Blue Metallic	Natural Black Burgundy Antique Sunburst	Natural Black Orange Sunburst Brown Sunburst	Natural Burgundy Antique Sunburst
Access Angle	Access Angle-II	Access Angle-II	Access Angle-II	Access Angle-II	Access Angle-II	Dove-tail	Dove-tail	Dove-tail
Black Chrome RM Pro	Chrome RM01	Chrome RM01	Chrome RM01	Vintage II	Vintage II	None	None	None
Africa V: 2 Humbucking	2 Single Coil, 7 Humbucking	2 Humbucking	1 Single Coil, 7 Humbucking	7 Humbucking	2 Single Coil, 7 Humbucking	Africa V: 2 Humbucking	Africa V: 2 Humbucking	Africa V: 2 Humbucking
3 Position	5 Position	3 Position	3 Position	None	5 Position	3 Position	3 Position	3 Position
Master Volume, Foot Volume, Tone	Master Volume, Master Tone	Master Volume, Master Tone	Master Volume, Master Tone	Master Volume	Master Volume, Master Tone	2 Volume, 2 Tone	2 Volume, 2 Tone	3 Volume, 2 Tone
Split	Split	Split	Split	None	None	Split	None	Split

Model	APX-20	APX-10	APX-10T	APX-7	APX-9-12	APX-6	APX-10N	APX-6N
Top	Solid Spruce Scalloped Bracing	Spruce Scalloped Bracing	Spruce Scalloped Bracing	Spruce	Spruce	Spruce	Spruce	Spruce
Back & Sides	Sycamore	Sycamore	Indian Rosewood	Agathis	Agathis	Okoume	Indian Rosewood	Okoume
Neck	African Mahogany	African Mahogany	African Mahogany	African Mahogany	African Mahogany	Nato	African Mahogany	Nato
Fingerboard	Bound Ebony	Bound Ebony	Bound Ebony	Bound Rosewood	Bound Rosewood	Indian Rosewood	Ebony	Indian Rosewood
Nut Width	1 7/16" (43 mm)	1 7/16" (43 mm)	1 7/16" (43 mm)	1 11/16" (45 mm)	1 3/16" (45 mm)	1 7/16" (43 mm)	1 7/8" (48 mm)	1 7/8" (48 mm)
Scale Length	25 5/8" (651 mm)	25 5/8" (651 mm)	25 5/8" (651 mm)	25 5/8" (651 mm)	25 1/16" (637 mm)	25 5/8" (651 mm)	25 5/8" (651 mm)	25 5/8" (651 mm)
Frets	24	24	24	24	24	24	24	22
Bridge	Ebony	Ebony	Ebony	Indian Rosewood	Indian Rosewood	Indian Rosewood	Brazilian Rosewood	Indian Rosewood
Nut & Saddle	Urea	Urea	Urea	Urea	Urea	Urea	Urea	Urea
Pickups	Stewie 2 way	Stewie 2 way	Stewie 2 way	2 way	Stewie 2 way	2 way	Stewie 2 way	2 way
Controls	Volume, Treble Bass, Mtr B-Mode Stems/Mono Battery Check	Volume, Treble Bass, Mtr B-Mode Stems/Mono Battery Check	Volume, Treble Bass, Mtr B-Mode Stems/Mono Battery Check	Volume, Treble Bass, Mtr	Volume, Treble Bass, Mtr B-Mode Stems/Mono Battery Check	Volume, Treble Bass, Mtr	Volume, Treble Bass, Mtr B-Mode Stems/Mono Battery Check	Volume, Treble Bass, Mtr
Colors	Cream White Black Sunburst Light Brown Sunburst	Black Sunburst Antique Sun Sunburst Burgundy	Natural	Light Brown Sunburst Black Blueburst	Blueburst Black Light Brown Sunburst	Light Brown Cream White Black		

BB 1600 <sup>1</sup>	BB 430	BB 350F	BB 300 <sup>1</sup>	BX 1	BX 5	MB II	MB III
Maple	Maple	Maple	Maple	Maple/Mahogany	Maple/Mahogany	Maple	Maple
Rosewood	Rosewood	Rosewood	Rosewood	Ebony	Ebony	Rosewood	Rosewood
1 5/8" (48 mm)	1 11/16" (45 mm)	1 11/16" (45 mm)	1 7/16" (43 mm)	1 5/8" (48 mm)	1 5/8" (48 mm)	1 5/8" (48 mm)	1 5/8" (48 mm)
10" (250 mm)	10" (250 mm)	10" (250 mm)	10" (250 mm)	10" (250 mm)	10" (250 mm)	10" (250 mm)	10" (250 mm)
13 7/8" (350 mm)	13 7/8" (350 mm)	13 7/8" (350 mm)	13 7/8" (350 mm)	13 7/8" (350 mm)	13 7/8" (350 mm)	13 1/4" (340 mm)	13 5/8" (346 mm)
21	21	None	21	21	21	24	24
Alder	Alder	Alder	Nato	Nato	Nato	Agathis	Basswood
Black Cream White Carmel Blue	Burnt Orange Two-Tone Sunburst Candy Apple Red Black	Black Pearl White Candy Apple Red	Black Pearl White Candy Apple Red	Black Candy Apple Red	Black Silver Pearl	Black Pearl White Candy Apple Red	Black Power Purple Pearl White
Body	Body	Body	Body	Neck-thru-body	Neck-thru-body	Body	Body
Di-cast/DK	Di-cast/DK	Low Mass	Di-cast/DK	Fine Tuning	Fine Tuning	Fine Tuning	Di-cast/DK
Split Single Coil, for magnet Single Coil	Split Single Coil, Sunburst Single Coil	Soft Single Coil Standard Single Coil	Split Single Coil	Africa V: High Output Humbucking	Africa V: High Output Humbucking	Africa V: Dual '75 Pole Humbucking	Dual '75 Pole Humbucking
2 Volumes, Master Tone	Volume, Tone, 3 Position Selector	Volume, Tone, 3 Position Selector	Volume, Tone	2 Volumes, Master Tone, Coil Split	2 Volumes, Master Tone, Coil Split	2 Volumes, Master Tone, Coil Split	2 Volumes, Master Tone, Coil Split

<sup>1</sup> Also available in left handed version: RGX 612SL, RGX 312L, SE 612L, SE 203ML, BB 1600L, BB 300L  
All specifications subject to change without notice.



**YAMAHA**

LEO198L 880R Printed in Japan