

# TAE62P3

BAKERY COMBI / PASTRY DECK COMBINATIONS



## Main Features

### HOOD

Exhaust Hood with Optional 400 or 600 mc3 Suction capacity.

### BAKING CHAMBER

- 6 Trays Capacity (600 x 400)
- Large 80mm Tray Spacing
- Self cleaning
- Weekly Auto Start Up
- 147 Baking Programs
- 2 speed fan regulation
- Bi-directional reversing fan system
- Halogen light
- Convection Cooking
- Combination Cooking
- Steam Cooking
- Probe Cooking
- Touch Panel User Control
- Automatic Preheat
- 6 Cooking Cycles for each Program
- Digital Steam Exhaust Regulation
- Water injection regulation

### DECK OVENS

- 2 x Teorema Polis Pastry Deck Ovens accommodating 2 x (600 x 400) trays each
- Stone / or steel base options
- Optional steam Boiler

### PROVER

- 3 Trays Capacity (600 x 400)
- Large 75mm Tray Spacing
- Proofer with pan-holder
- Optional humidifier
- Door made of tempered glass
- Castor wheels with brakes

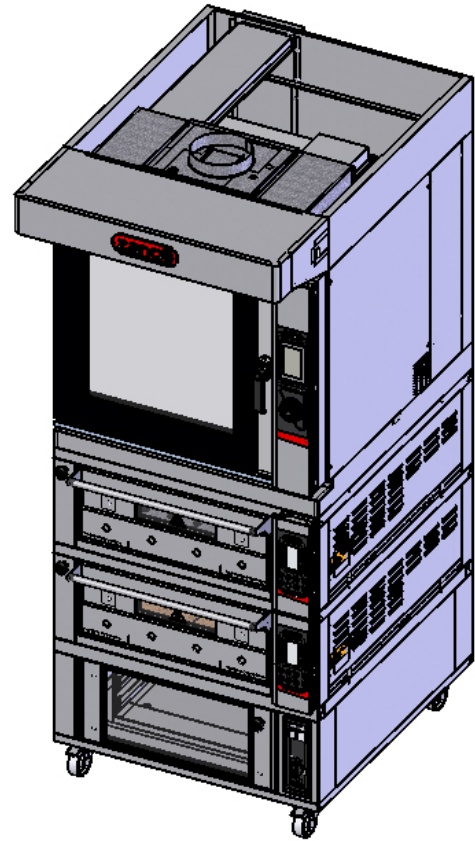

## SPECIFICATIONS

Voltage	400V 3 Phase
Power	24.3 kw
Weight	490 kg
Plug Supplied	No
Capacity	6 Trays (400 x 600) for Anemos Bakery Combi 4 Trays (400 x 600) for Teorema Polis Pastry Deck Ovens 3 Trays (400 x 600) for Proving Cabinet
Thermostat	260°C Teorema Anemos bakery Combi 400°C Teorema Polis Bakery Deck
Warranty	4 Year Warranty (2 yr Labour 4 yr Parts)

## COMPONENTS

1 X Ventilation Hood Top	1COM019A
1 X 6 Tray Teorema Anemos 6E/MC Touch Bakery Combi Oven	5FC0403
1 X Stacking Kit	1COM006A
2 X TPOLIS 2S 2 Tray Baking Deck Oven	2P02H05B
1 X 3 Tray Prover on Castors	1COM009A

## DIMENSIONS

External Width	970mm
External Depth	1351mm (including hood)
External Height	2371mm



Phone: 1800 183 818 Email: support@thegoodlady.com.au  
Website: www.thegoodlady.com.au

# TAE62P3

## EXHAUST HOOD STRUCTURE AND PROVISION

### FRONT

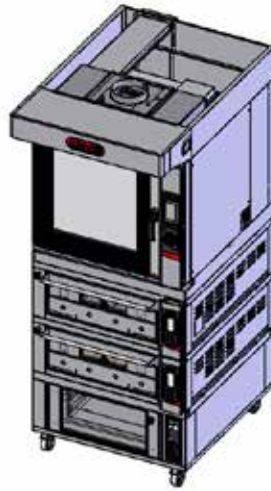
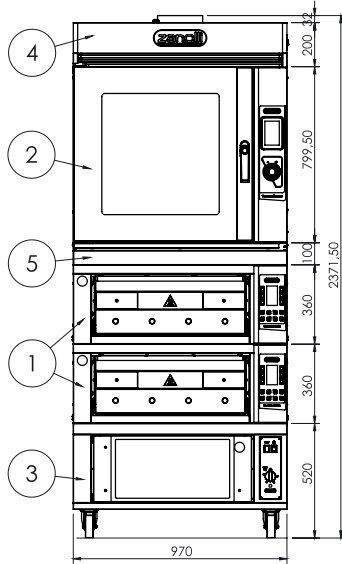

### SIDE

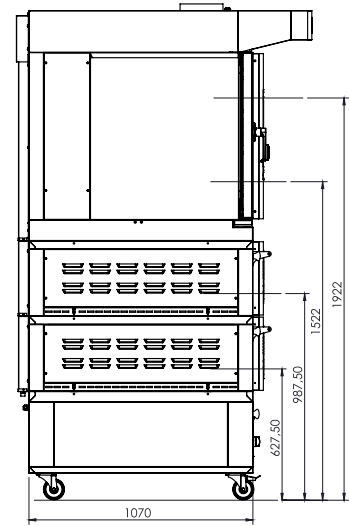

Item num.	Quantity	Description	Power	Trays	Distance between trays
1	2	T POLIS 2S	12,8 kW	n°4	
2	1	T ANEMOS 6E TOUCH	10,5 kW	n°6	80mm
3	1	PROOFING CABINET	1 kW	n°6	75mm
4	1	EXHAUST HOOD	0,3 kW		
5	1	KIT COMBI			
Optional			Power		
HUMIDIFIER FOR PROVING CABINET			1KW		
STEAM BOILER FOR DECK OVEN			2.8KW		

### REAR

### TOP

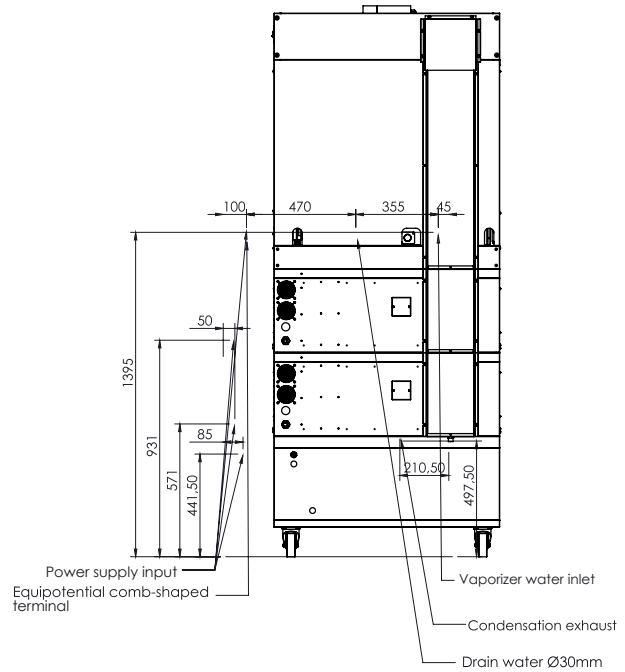
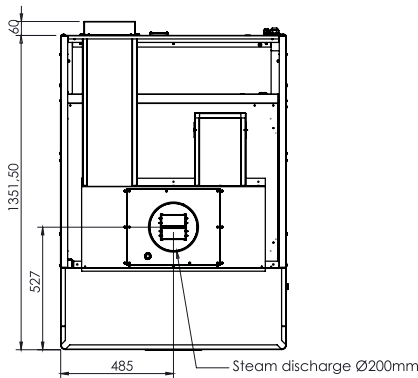

We reserve the right to alter specifications without notice.



Phone: 1800 183 818 Email: support@thegoodlady.com.au  
 Website: www.thegoodlady.com.au

# TAE62P3

## EXHAUST HOOD STRUCTURE, PROVISION & MOTOR (400M3/600M3 CAPACITY)

### FRONT

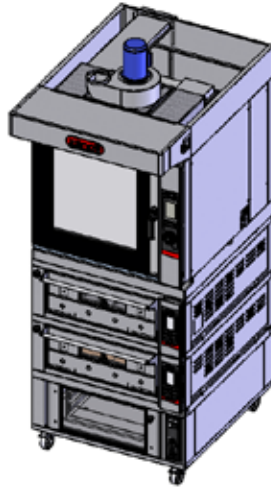
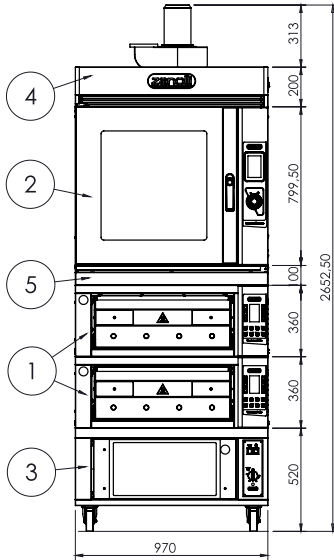

### SIDE

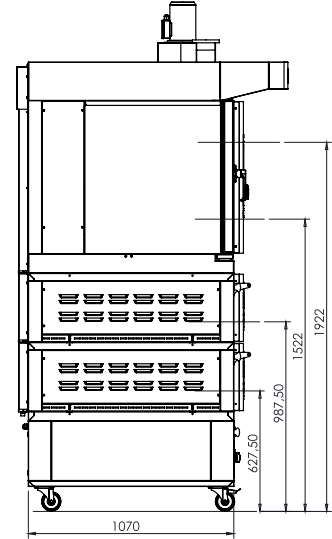

Item num.	Quantity	Description	Power	Trays	Distance between trays
1	2	T POLIS 2S	12.8 kW	n°4	
2	1	T ANEMOS 6E TOUCH	10.5 kW	n°6	80mm
3	1	PROOFING CABINET	1 kW	n°6	75mm
4	1	EXHAUST HOOD WITH MOTOR	0.25 kW		
5	1	KIT COMBI			
Optional		Power			
HUMIDIFIER FOR PROVING CABNIT		1KW			
STEAM BOILER FOR DECK OVEN		2.8KW			

### REAR

### TOP

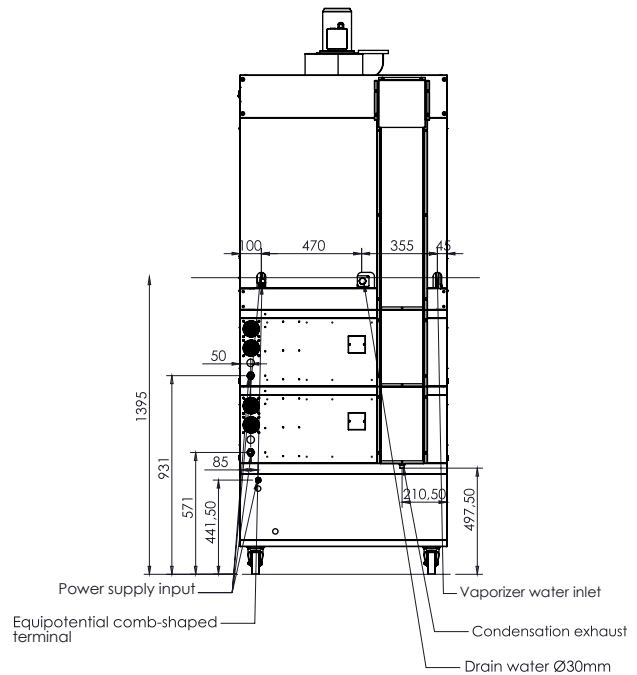
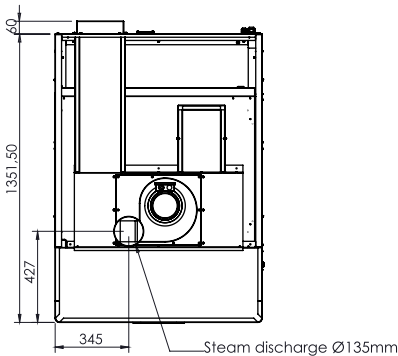

We reserve the right to alter specifications without notice.



Phone: 1800 183 818 Email: support@thegoodlady.com.au  
Website: www.thegoodlady.com.au

# TAE62P3

## NO EXHAUST PROVISION

### FRONT

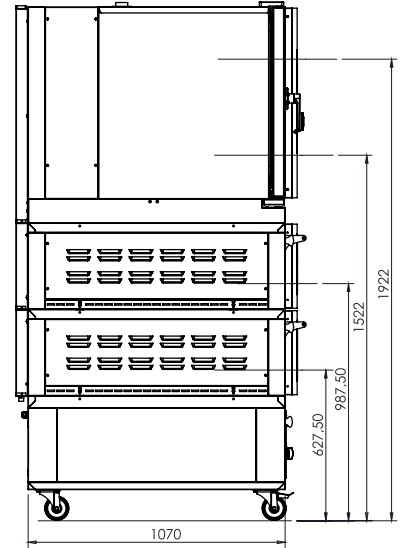
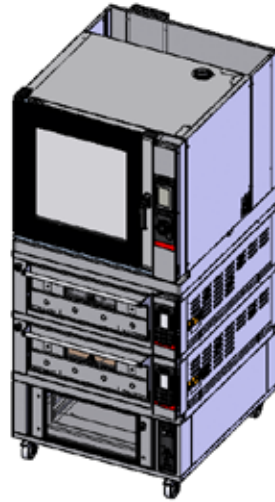
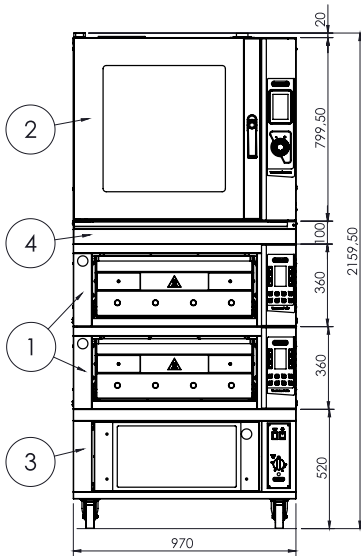

Item num.	Quantity	Description	Power	Trays	Distance between trays
1	2	T POLIS 2S	12.8 kW	n°4	
2	1	T ANEMOS 6E TOUCH	10.5 kW	n°6	80mm
3	1	PROOFING CABINET	1 kW	n°6	75mm
4	1	KIT COMBI			
Optional		Power			
HUMIDIFIER FOR PROVING CABINET		1KW			
STEAM BOILER FOR DECK OVEN		2.8KW			

### REAR

### TOP

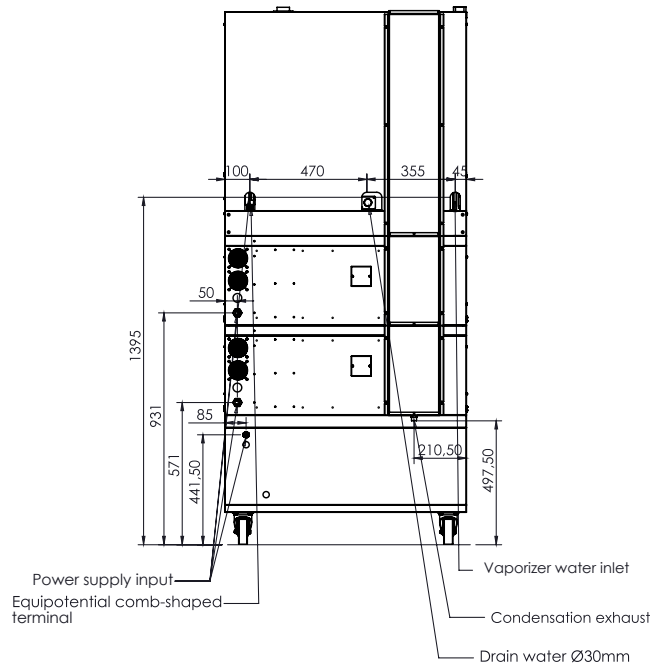
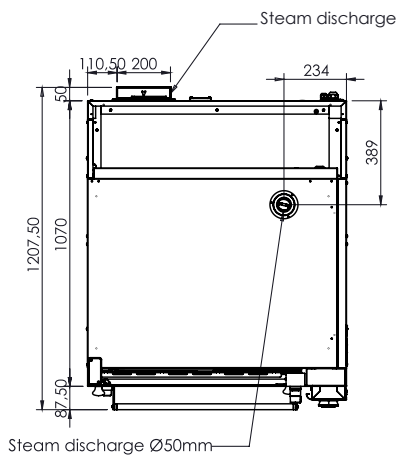

We reserve the right to alter specifications without notice.



THE  
GOOD  
LADY

Phone: 1800 183 818 Email: support@thegoodlady.com.au  
Website: www.thegoodlady.com.au