

SYNTHESIS 05/40

COMPACT ELECTRIC CONVEYOR OVEN

2SV4206A



SPECIFICATIONS

Voltage	Trifase / Monofase - 230/400 Vac 50-60 Hz
	Current at 220-240 V~ 27,2 A
	Current at 380-415 V 3N~ 13 A
Max Power	6300 Watts
Weight	77 kg
Plug Supplied	No, lead only
Noise level	<70 decibels
Belt Width	16" (400mm)
Conveyor Length	1070mm
Chamber Length	570mm
Chamber Height	90mm
Cable Length	2 meters
Time Range	2 minutes - 30 minutes (or complete halt)
Thermostat	320°C
Ambient Temp	0- 40°C
Max Humidity	95% without condensation
Warranty	4 Year Warranty (2 yr Labour 4 yr Parts)



Main Features

- Made entirely from stainless steel
- Easy access for thorough cleaning
- Cooling system for contact parts
- Conveyor belt with variable speed down to a complete halt
- Fine tuning of the ventilation flow
- Jets of hot air completely wrap the product as it moves along the wire mesh conveyor giving an evenly cooked result time after time
- All Synthesis ovens are stackable so you can step up your productivity to meet peak demand

DIMENSIONS

External Width	1270mm	Internal Width	400mm
External Depth	800mm	Internal Depth	570mm
External Height	390mm	Internal Height	90mm

ACCESORIES

05/40 Stand



Phone: 1800 183 818 Email: support@thegoodlady.com.au
 Website: www.thegoodlady.com.au

FRONT

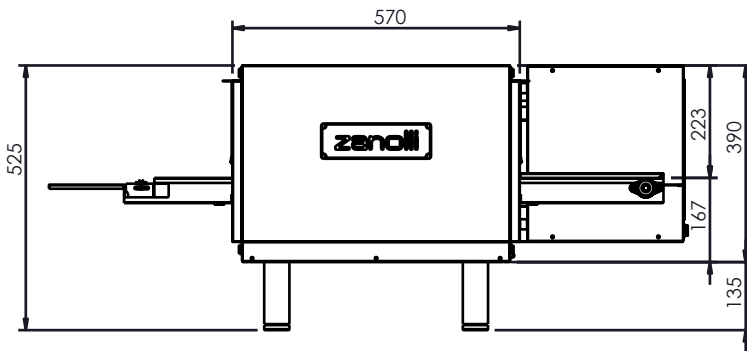

SIDE

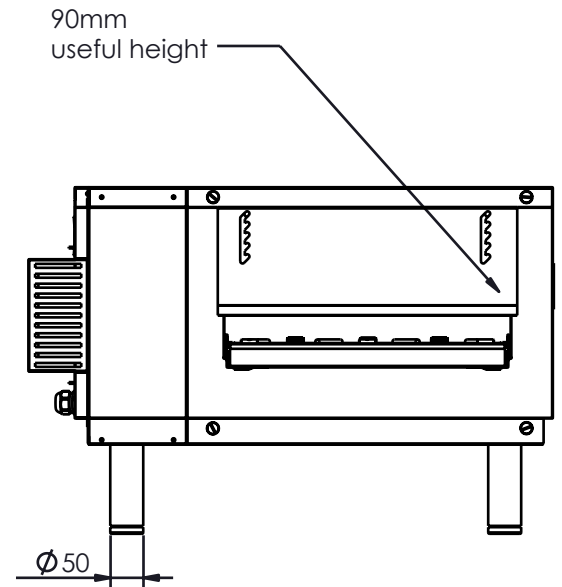

TOP

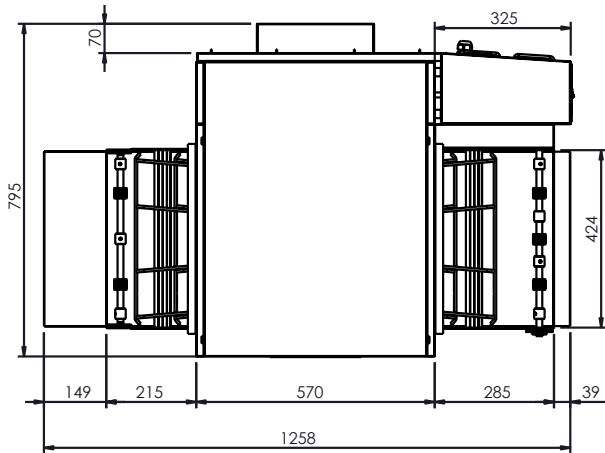

REAR

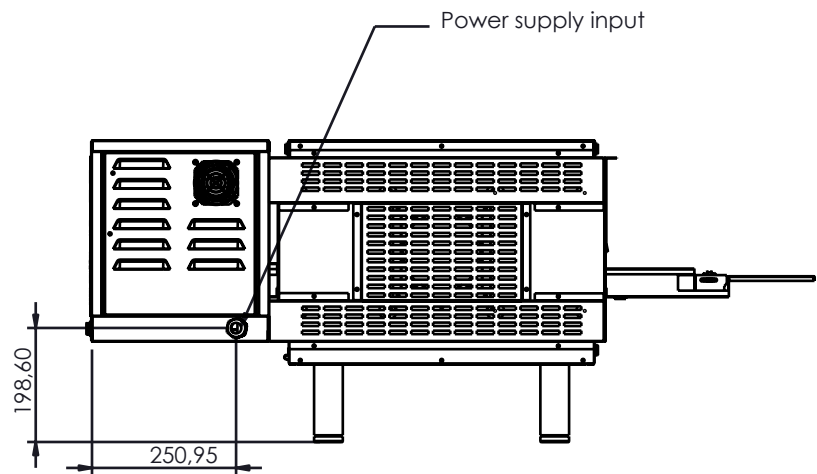

We reserve the right to alter specifications without notice.



THE
GOOD
LADY

Phone: 1800 183 818 Email: support@thegoodlady.com.au
Website: www.thegoodlady.com.au