

SIRIO 600/1000

FREESTANDING DOUGH SHEETERS

COMIDA

Main Features

- Digital display to show the rolling thickness and ensure the most accurate adjustments
- Possibility of inverting the rolling direction by means of joystick and foot pedal
- The synchronized speed of the conveyor belts are fixed at a single speed.
- Removable flour tray for easy cleaning
- The plates can be closed, thus allowing to keep the machine size smaller, when not in use
- The machines are mounted on wheels for their easy displacement



SPECIFICATIONS

Voltage	400Vac 3 50Hz
Power	0.75kw
Speed	Single Speed
Weight	229kg
Plug Supplied	No
Belt Length	1000mm Each Side
Belt width	600mm
Noise Level	< 70 decibels
Humidity	95% without condensation
Ambient Temperature	40°C Max
Warranty	4 Year Warranty (2 yr Labour 4 yr Parts)

STANDARD - Single Speed Operation



OPTIONAL VARIABLE SPEED - Single Phase Operation



DIMENSIONS

External Width	2490mm
External Depth	1090mm
External Height	1300mm



Phone: 1800 183 818 Email: support@thegoodlady.com.au
 Website: www.thegoodlady.com.au

FRONT

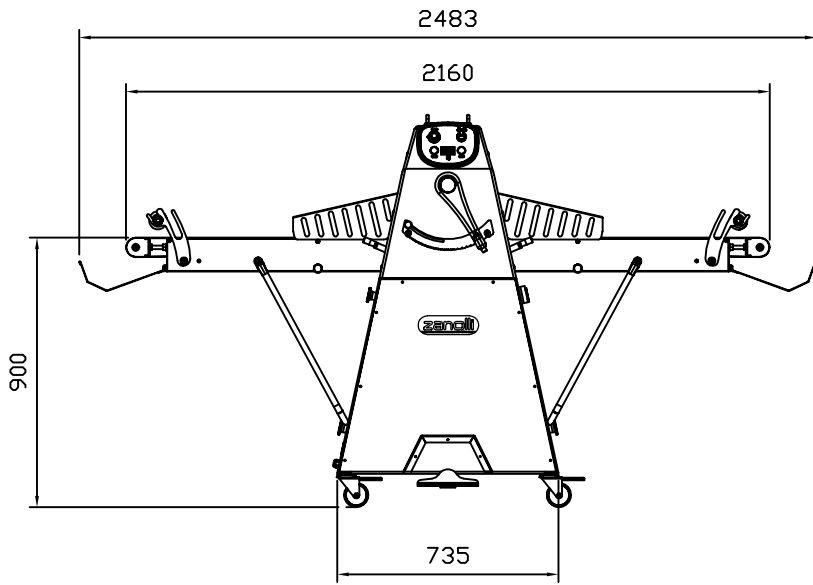

SIDE

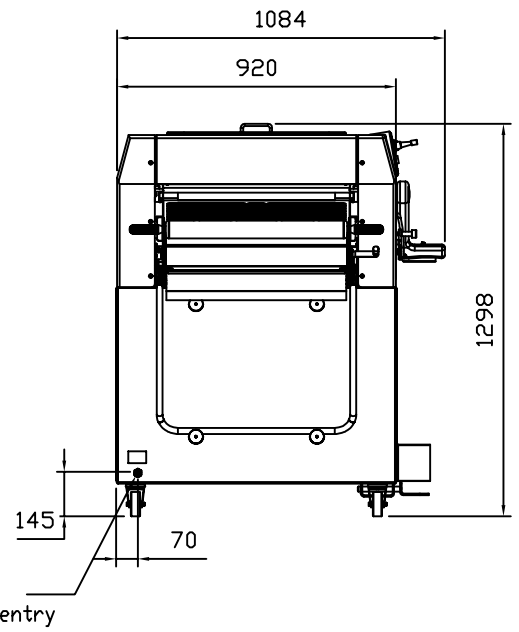

TOP

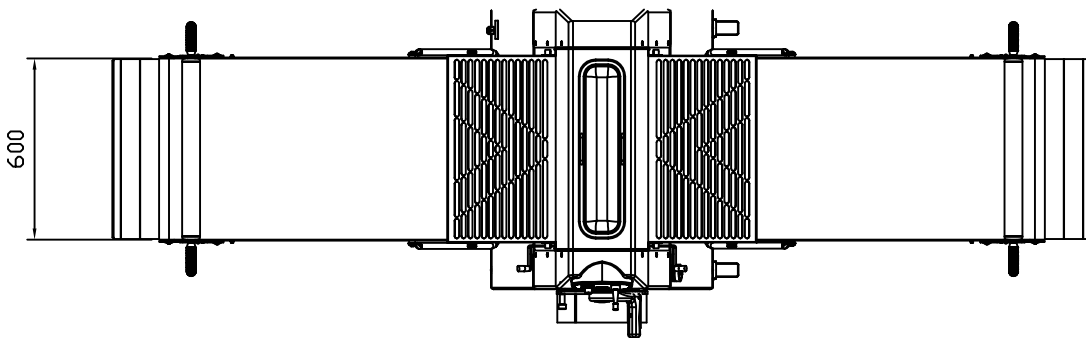

We reserve the right to alter specifications without notice.



THE
GOOD
LADY

Phone: 1800 183 818 Email: support@thegoodlady.com.au
Website: www.thegoodlady.com.au