



### General Features

- ◆ Sealed and maintenance free operation.
- ◆ Non-Spillable construction design.
- ◆ ABS containers and covers(UL94HB, UL94V-0) optional.
- ◆ Safety valve installation for explosion proof.
- ◆ High quality and high reliability.
- ◆ Exceptional deep discharge recovery performance.
- ◆ Low self discharge characteristic.
- ◆ Flexibility design for multiple install positions.



Battery Type	Valve-Regulated, Absorbed Glass Mat (AGM) Technology			
Nominal Voltage	6V			
Capacity(20°C)	20HR(10.1A, 1.8V/cell)	10HR(19.4A, 1.80V)	5HR(33.4A, 1.75V)	1HR(117A, 1.60V)
	202.0AH	194.0AH	167.0AH	117AH
Dimensions	Length	Width	Height	Total Height
	322mm(12.68inches)	178mm(7.01inches)	228mm(8.98inches)	234mm(9.21inch)
Approx Weight	Approx 32.5 kg (71.7lbs)			
Internal Resistance	Full Charged at 20°C : Approx 1.4mΩ			
Self Discharge	3% of capacity declined per month at 20°C			
Capacity affected by Temperature(10HR)	40°C	25°C	0°C	-15°C
	103%	100%	86%	65%
Charging Voltage (V)	Cycle use		Float use	
	7.2V~7.5V at 20 °C. Temp. Coefficient -15mV/°C		6.75V~6.9V at 20°C. Temp. Coefficient (-10mV/°C)	
Current	Max. Discharge Current		Initial Charging Current	
	2000A		Less than 60.0A	
Operating Temp. Range	Discharge		Charging	
	-15~50°C (5~122°F)		0~40°C (32~104°F)	
			Storage	
			-15~40°C (5~104°F)	

### Constant Current Discharge (Amperes) at 20 °C (68°F)

F.V/Time	5min	10min	15min	20min	30min	45min	1h	2h	3h	4h	5h	6h	8h	10h	20h
1.85V/cell	325	256	217	182	146	111	90.5	57.7	45.6	37.2	30.3	26.4	21.4	18.3	10.0
1.80V/cell	437	327	263	215	172	129	101	62.9	49.1	39.8	32.6	28.3	22.7	19.4	10.1
1.75V/cell	492	359	287	231	179	133	106	65.3	50.0	40.6	33.4	29.1	23.1	19.6	10.2
1.70V/cell	542	391	306	243	186	139	109	67.9	51.4	41.7	34.3	29.7	23.5	19.8	10.4
1.65V/cell	598	422	326	258	196	142	113	69.8	53.5	43.2	35.2	30.4	23.8	20.2	10.5
1.60V/cell	659	458	348	275	207	148	117	72.1	55.2	44.5	36.4	31.0	24.1	20.4	10.6

### Constant Power Discharge (Watts) at 20 °C (68°F)

F.V/Time	5min	10min	15min	20min	30min	45min	1h	2h	3h	4h	5h	6h	8h	10h	20h
1.85V/cell	595	472	406	343	278	212	175	112	88.9	72.8	59.4	51.9	42.3	36.2	19.8
1.80V/cell	790	596	484	399	323	245	195	121	95.1	77.3	63.6	55.5	44.8	38.3	20.0
1.75V/cell	871	645	522	425	333	252	203	125	96.4	78.8	65.0	56.8	45.4	38.7	20.1
1.70V/cell	933	687	549	444	345	261	208	130	99.0	80.7	66.5	57.9	46.0	39.0	20.5
1.65V/cell	1014	734	580	468	361	265	214	133	103	83.2	68.1	59.0	46.6	39.8	20.7
1.60V/cell	1093	779	610	493	378	275	220	137	105	85.5	70.1	60.1	47.0	40.1	20.8



# Dimensions

## T11 Terminal

Unit: mm [inches]

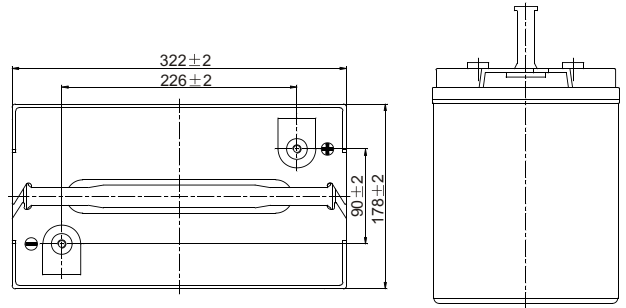
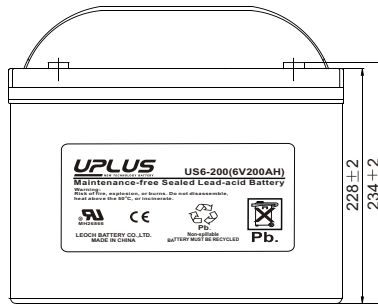
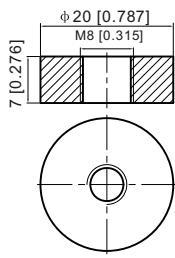

Torque: 11~14.7N\*M

## Float charging characteristics

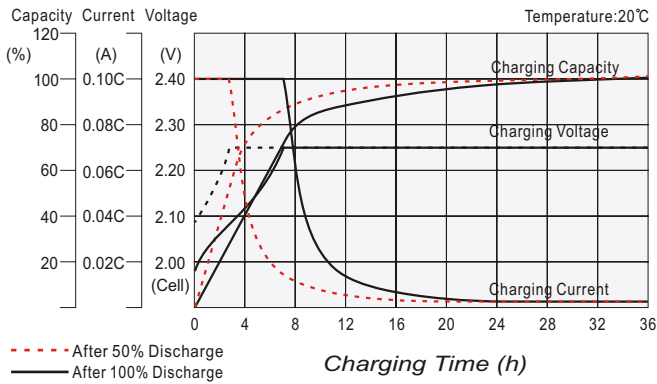

## Cycle use charging characteristics

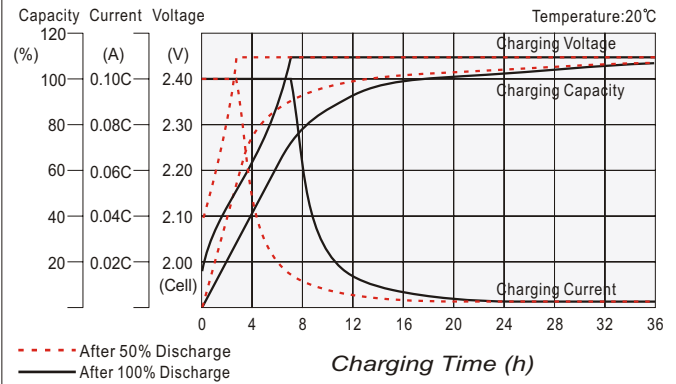

## Effect of Temperature on Long Term Float Life

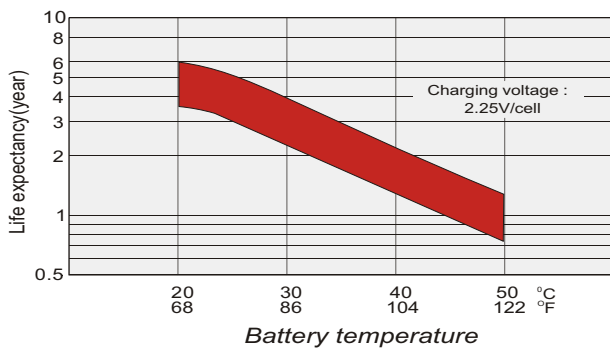

## Discharge characteristics

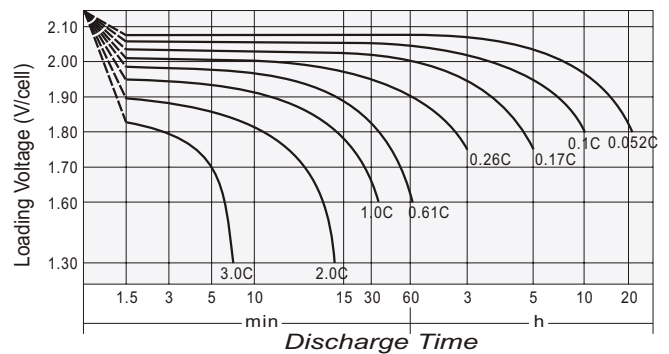

## Cycle Life in Relation to Depth of Discharge

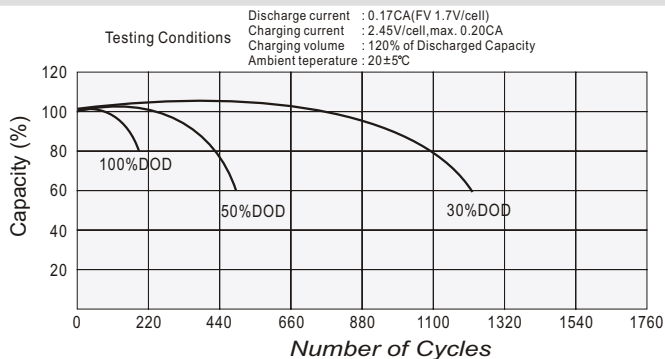

## Self Discharge Characteristics

