

Artist Roster

GUITARS

Carl A. Tidemann
Keith Azami
Tosin Abasi
Dave Aguilera
Edouard Aigallion
Simon Andersson
Fabián Aravalés
Cory Arford
Yann Armellino
Lance Army
Chris Arp
Cristobal Ariagada
Oat Azeong
Boonsermsup
Matt Aub
Paul Baayens
Matt Bachand
Daniel Bage
Rob Balducci
Ball
Terry Balsamo
Way Barrier
Javier Bassino
Rikk Beatty
Honza Kirk Behunek
Steve Bello
Ricky Belloni
Justin Bender
Beng Beng
Jackson Bengé
George Benson
Sammy Black
Stijn Borgers
Chris Broderick
Norman Brown
Steve Brown
JB Brubaker
Tobias Buck
Thomas "BUSCHI" Buschhausen
Gizy Burt
Rudi Buttas
Martin Buus
Chris Camozzi
Noah Carpenter
Dan Carter
Frank Caruso
Cat Casino
Giacomo Castellano
Dino Cazares
Cesareo
Curtis Chambers
Andy Chandler
Sergo Chanturiy
Sebastien Chaput
Pascal Chesaux
Josh Childers
Audley Chisholm
Choky
Alex Colin-Tocqaine
Claudio Cordero
Chad Crawford
Rob Daniels
Bjorn Dannov
Scott Danough
Jim Davies
Juan De Ferrari
LC de Leon
Deehellix
Isaac Delahaye
Koen Delanghe
Brad Delson
Mike Dewolf
Dominic
Doug Doppler
Fletcher Drage
Torben Evoldsen
Nidas Engelin
Marty Evans
Ryan Felton
Gianluca Ferro
Rui Fingers
Jon Finn
Tom Fischer
Max Flövik
Georges Floride
David Fransson
Marty Friedman
Justin Furstenfeld
Robbie Furze
Fuzz
Per Gade
Fabien Galland
Pablo Garcia
Adriel Garcia
Roland Gebhardt
Mark Gemini Thwaite
Rocky George
Andreas Gerhard
Susan Gerl
Paul Gilbert
Peter Goemaere
Matt Good
Cristi Gram
Graz
Jon Greasley
Karl Groom
Ryan Gudmunds
Trent Haf Dahl
Mårten Hagström
Joel Haines
Paul Hanson
AJ Harvey
Simon Hawemann
Kasper Heikinen
Oli Herbert
Tony Hernandez
Gabriel Hidalgo
Nick Hipa
Hiro
Pontus Hjelm
Sander Hoek
Wojciech Hoffmann
Dexter Holland

Bad Acid Trip
Animals As Leaders
Star Academy
Avatar
Blackout
Carnifex
Flaw
Psychop, Hank Williams III
Alejandro Silva Power Cuarteto, KLUSTR
Street Funk Rollers
Timelord
Hall of Bullies
Shadows Fall
Mutiny Within
Bangkaew
Evanescence
Destroy Destroy Destroy
Farenheit
Riik Beatty Band
Solo Artist, SEVEN
Steve Bello Band
II Mito New Trolls
Into Eternity
Pas
(hed) planet earth
LOVEEX
Poison My Blood
Megadeth
Ignominious Incarceration
August Burns Red
Neera
Galejon
The More I See
PIIR
Mercenary
Michael Bolton
Skinless
The Lucky Nine
Arachnes, Strings 24
Deathstars
Gianna Nannini, Solo Artist
Fear Factory, Divine Heresy
Elio e Le Storie Tese
Franklin Bridge
In Dread Response, Bloodletting
Ion Dissonance
P.M.T. - Pre Menstrual Tension
The Showdown
Maxi Priest, Big Mountain
Metal
Agressor/Loubblast
Matraz
Scary Kids Scaring Kids
Jimmy Wayne Band
Abigail Williams
Hypes, Victory Pill
Cultura Tres
Reklamo
Epic
Poison My Blood
Linkin Park
Taproot
The Chronicals of Israel
Doppler Inc.
Penrywise
Section A
Egael
Trigger The Bloodshed
CHAOS DIVINE
Time Machine, Strings 24
Pablo Gonzo
Jon Finn Group
Trypkyon
Lilliasyster
Jadallys
Divison of Laura Lee
Blas October
PANIC DHH
Rollo, Deep Banana Blackout
Billy Cobham, Alito Moreira
Julie Zenatti
Warcy
City Sleeps
Ro Gebhardt's Blow
The Mission, Tricky
Fishbone
Aloha from Hell
God Dethroned
MR. BIG
Aborted
From First to Last
Phoenix
Mushroomhead
Vega
All Shall Perish
Delcide
Dr. Z
Straight Line Stitch
Markonee
Burn, DJ Bobo, Tangerine Dream
Weiche
EISBRÜCHER
Ambition Down
Benoit POL Group
Aria
Vanishing Point
Lucio Dalla
The Eyes Of A Traitor
Trigger The Bloodshed
Airless
Necrophagist
Saiko

Steve Holt
Tom "Famy" Holter
Bernhard Horn
Luke Hoskin
Bill Hudson
Scott Hull
Ihsahn, Emperor
Deathstars
Hot Rod Circuit
Mutiny Within
Epica
Avatar
Armchair
Peung Jatutapong Rumaklom
Bane Jelic
Juan Carlos Jimenez Gomez
Rob Johnson
Steve Jones
Juan Juarez
Chris Kane
Kjell Åge "Damage" Karlson
Karukan
Alexander Kaschte
Ilder Kazahanov
Stefan Keller
Kessler
Jesse Ketive
Vladimir Khoryjii
Gav King
Kin ky
Sean Kipe
Steve Kirby
Matthias Kirchgesser
Jon Kita
Ryan Knight
Siméon Koch
Koko
Kirk Kolaitis
Nikolay Kotov
Eric Krasno
Tony Laisto
John Lamacchia
Lanvall
Igor Lapuhin
Jimmy Lardner-Brown
Parker Lauzon
Benjamin Lechuga
Alex Lee
Gary Lenaire
Fabrizio Leo
Brian Leppke
Mike Lerner
Eyal Levi
Cugeny Levin
Herman Li
Christian Lidsba
Holger Lieberenz
Jani Lilmatainen
Chen-Yi Lin
Ben Lionetti
Manu Livertout
Juan Pablo Lobos
Logan
Loki
Alejandro Londoño
Juan Carlos Martin Lopez
Justin Lowe
Flemming Lund
Antoine Lussier
Jari Mäenpää
Teemu Mäntysaari
Christian Münzner
Tony MacAlpine
Mark MacDonald
Andrea Maddalone
Brian Maillard
Lee Malia
Christopher Malmström
Patrick Marnell
David Manley
Khan Manuel
Andy Martin
Orazio Martino
Buz McGrath
James McKillop
Lee McKinney
Patrick Meadows
Sander van der Meer
Pat Metheny
Krzysztof Misiak
Larry Mitchell
Mark Mitchell
Atsushi Miyamoto
Alexandr Mogilevskiy
Monte Money
Oskar Montelius
Munky
Yasushi Muratori
Stephen Murphy
Kamal Musallam Group
Kristian Niemann
Johan Niemann
Per Nilsson
Noodles
Pekka Oikkonen
Magnus Olsson
Ben Orum
Jack Owen
David Palau
Rob Patterson
Pat Pattison
Pera
Zlatko "Slädu" Perica
Angelo Pierattini
Jürgen Plangger
Emil Pohjalainen
Benoit POL Group
Aria
Vanishing Point
Lucio Dalla
The Eyes Of A Traitor
Trigger The Bloodshed
Airless
Necrophagist
Saiko

36 Crazyfists
Wip Wam
Callejon
Protest the Hero
Written in Blood, Circle II Circle
Pig Destroyer
Ihsahn, Emperor
Deathstars
Hot Rod Circuit
Mutiny Within
Epica
Avatar
Armchair
Marilisa
Roch Voisine Wazimba
Yannick Robert
3 Doors Down
Eternal Now
The Mars Volta
Dama Juana
The Casual's, Solo Artist
Alisa
Patrick Rondat, Elegy
Into Eternity
Melendi
Ida Landsberg Trio, Solo Artist
God Dethroned
Letzte Instanz
Crave
Nevio
John Scofield
Jeremiah Scott
Jake Scott
Arthur Seay
Roni Seppänen
Justin Shah
Justin Shekoski
Mike Shinoda
Tony Shoaf
Shave
Christoph Siemons
Dwight Sills
Alejandro Silva
Roger Sjunnesson
Terji Skibenaz
Michael Soibinen
Ralf Sommerfeld
Waldemar Soryccha
Felipe Souza
Chris Stalder
Pablo Stipicic
Benny Stock
Nita Strauss
Vince Stropi
Muhammed Suicmez
Rikard Sundén
Marcus Sunesson
Ken Susi
Tommy Sveta
Jon Symons
Vlad Tanaskovic
Jaime Teisere
Chris Telis
Seth Theaker
Bobby Thompson
Mick Thomson
Fredrik Thordendal
Frank Tijink
Andy Timmons
Tobias
Ton
Tora
Gisle Torvik
Sam Totman
Rares Totu
Koji Tsumoto
Olli Tuohimäen
Sébastien Turi
Dave Ulrich
U-Nam
Patrick Uterwijk
Ludovico Vagnone
Steve Vai
Javi Valero
Sander van der Meer
Chema Vilchez
Elias Viljanen
Tommy Vucur
Everton Waldman
Pop Warabit
Yu Watanabe
Bob Weir
Brian "Head" Welch
Oskar Montelius
Munky
Yasushi Muratori
Stephen Murphy
Kamal Musallam Group
Kristian Niemann
Johan Niemann
Per Nilsson
Noodles
Pekka Oikkonen
Magnus Olsson
Ben Orum
Jack Owen
David Palau
Rob Patterson
Pat Pattison
Pera
Zlatko "Slädu" Perica
Angelo Pierattini
Jürgen Plangger
Emil Pohjalainen
Benoit POL Group
Aria
Vanishing Point
Lucio Dalla
The Eyes Of A Traitor
Trigger The Bloodshed
Airless
Necrophagist
Saiko

August Burns Red
Jive Talking, Cradle
Draven
Red
Beverly Knight, Liberty X, Billy Crawford, Ms Dynamite
BLINDSPOTT
VVD
myGRAIN
Taproot
All Shall Perish
Timelord
RIME
Deja Voodoo Spells
Marilisa
Roch Voisine Wazimba
Yannick Robert
3 Doors Down
Eternal Now
The Mars Volta
Dama Juana
The Casual's, Solo Artist
Alisa
Patrick Rondat, Elegy
Into Eternity
Melendi
Ida Landsberg Trio, Solo Artist
God Dethroned
Letzte Instanz
Crave
Nevio
John Scofield
Jeremiah Scott
Jake Scott
Arthur Seay
Roni Seppänen
Justin Shah
Justin Shekoski
Mike Shinoda
Tony Shoaf
Shave
Christoph Siemons
Dwight Sills
Alejandro Silva
Roger Sjunnesson
Terji Skibenaz
Michael Soibinen
Ralf Sommerfeld
Waldemar Soryccha
Felipe Souza
Chris Stalder
Pablo Stipicic
Benny Stock
Nita Strauss
Vince Stropi
Muhammed Suicmez
Rikard Sundén
Marcus Sunesson
Ken Susi
Tommy Sveta
Jon Symons
Vlad Tanaskovic
Jaime Teisere
Chris Telis
Seth Theaker
Bobby Thompson
Mick Thomson
Fredrik Thordendal
Frank Tijink
Andy Timmons
Tobias
Ton
Tora
Gisle Torvik
Sam Totman
Rares Totu
Koji Tsumoto
Olli Tuohimäen
Sébastien Turi
Dave Ulrich
U-Nam
Patrick Uterwijk
Ludovico Vagnone
Steve Vai
Javi Valero
Sander van der Meer
Chema Vilchez
Elias Viljanen
Tommy Vucur
Everton Waldman
Pop Warabit
Yu Watanabe
Bob Weir
Brian "Head" Welch
Oskar Montelius
Munky
Yasushi Muratori
Stephen Murphy
Kamal Musallam Group
Kristian Niemann
Johan Niemann
Per Nilsson
Noodles
Pekka Oikkonen
Magnus Olsson
Ben Orum
Jack Owen
David Palau
Rob Patterson
Pat Pattison
Pera
Zlatko "Slädu" Perica
Angelo Pierattini
Jürgen Plangger
Emil Pohjalainen
Benoit POL Group
Aria
Vanishing Point
Lucio Dalla
The Eyes Of A Traitor
Trigger The Bloodshed
Airless
Necrophagist
Saiko

August Burns Red
Jive Talking, Cradle
Draven
Red
Beverly Knight, Liberty X, Billy Crawford, Ms Dynamite
BLINDSPOTT
VVD
myGRAIN
Taproot
All Shall Perish
Timelord
RIME
Deja Voodoo Spells
Marilisa
Roch Voisine Wazimba
Yannick Robert
3 Doors Down
Eternal Now
The Mars Volta
Dama Juana
The Casual's, Solo Artist
Alisa
Patrick Rondat, Elegy
Into Eternity
Melendi
Ida Landsberg Trio, Solo Artist
God Dethroned
Letzte Instanz
Crave
Nevio
John Scofield
Jeremiah Scott
Jake Scott
Arthur Seay
Roni Seppänen
Justin Shah
Justin Shekoski
Mike Shinoda
Tony Shoaf
Shave
Christoph Siemons
Dwight Sills
Alejandro Silva
Roger Sjunnesson
Terji Skibenaz
Michael Soibinen
Ralf Sommerfeld
Waldemar Soryccha
Felipe Souza
Chris Stalder
Pablo Stipicic
Benny Stock
Nita Strauss
Vince Stropi
Muhammed Suicmez
Rikard Sundén
Marcus Sunesson
Ken Susi
Tommy Sveta
Jon Symons
Vlad Tanaskovic
Jaime Teisere
Chris Telis
Seth Theaker
Bobby Thompson
Mick Thomson
Fredrik Thordendal
Frank Tijink
Andy Timmons
Tobias
Ton
Tora
Gisle Torvik
Sam Totman
Rares Totu
Koji Tsumoto
Olli Tuohimäen
Sébastien Turi
Dave Ulrich
U-Nam
Patrick Uterwijk
Ludovico Vagnone
Steve Vai
Javi Valero
Sander van der Meer
Chema Vilchez
Elias Viljanen
Tommy Vucur
Everton Waldman
Pop Warabit
Yu Watanabe
Bob Weir
Brian "Head" Welch
Oskar Montelius
Munky
Yasushi Muratori
Stephen Murphy
Kamal Musallam Group
Kristian Niemann
Johan Niemann
Per Nilsson
Noodles
Pekka Oikkonen
Magnus Olsson
Ben Orum
Jack Owen
David Palau
Rob Patterson
Pat Pattison
Pera
Zlatko "Slädu" Perica
Angelo Pierattini
Jürgen Plangger
Emil Pohjalainen
Benoit POL Group
Aria
Vanishing Point
Lucio Dalla
The Eyes Of A Traitor
Trigger The Bloodshed
Airless
Necrophagist
Saiko

August Burns Red
Jive Talking, Cradle
Draven
Red
Beverly Knight, Liberty X, Billy Crawford, Ms Dynamite
BLINDSPOTT
VVD
myGRAIN
Taproot
All Shall Perish
Timelord
RIME
Deja Voodoo Spells
Marilisa
Roch Voisine Wazimba
Yannick Robert
3 Doors Down
Eternal Now
The Mars Volta
Dama Juana
The Casual's, Solo Artist
Alisa
Patrick Rondat, Elegy
Into Eternity
Melendi
Ida Landsberg Trio, Solo Artist
God Dethroned
Letzte Instanz
Crave
Nevio
John Scofield
Jeremiah Scott
Jake Scott
Arthur Seay
Roni Seppänen
Justin Shah
Justin Shekoski
Mike Shinoda
Tony Shoaf
Shave
Christoph Siemons
Dwight Sills
Alejandro Silva
Roger Sjunnesson
Terji Skibenaz
Michael Soibinen
Ralf Sommerfeld
Waldemar Soryccha
Felipe Souza
Chris Stalder
Pablo Stipicic
Benny Stock
Nita Strauss
Vince Stropi
Muhammed Suicmez
Rikard Sundén
Marcus Sunesson
Ken Susi
Tommy Sveta
Jon Symons
Vlad Tanaskovic
Jaime Teisere
Chris Telis
Seth Theaker
Bobby Thompson
Mick Thomson
Fredrik Thordendal
Frank Tijink
Andy Timmons
Tobias
Ton
Tora
Gisle Torvik
Sam Totman
Rares Totu
Koji Tsumoto
Olli Tuohimäen
Sébastien Turi
Dave Ulrich
U-Nam
Patrick Uterwijk
Ludovico Vagnone
Steve Vai
Javi Valero
Sander van der Meer
Chema Vilchez
Elias Viljanen
Tommy Vucur
Everton Waldman
Pop Warabit
Yu Watanabe
Bob Weir
Brian "Head" Welch
Oskar Montelius
Munky
Yasushi Muratori
Stephen Murphy
Kamal Musallam Group
Kristian Niemann
Johan Niemann
Per Nilsson
Noodles
Pekka Oikkonen
Magnus Olsson
Ben Orum
Jack Owen
David Palau
Rob Patterson
Pat Pattison
Pera
Zlatko "Slädu" Perica
Angelo Pierattini
Jürgen Plangger
Emil Pohjalainen
Benoit POL Group
Aria
Vanishing Point
Lucio Dalla
The Eyes Of A Traitor
Trigger The Bloodshed
Airless
Necrophagist
Saiko

August Burns Red
Jive Talking, Cradle
Draven
Red
Beverly Knight, Liberty X, Billy Crawford, Ms Dynamite
BLINDSPOTT
VVD
myGRAIN
Taproot
All Shall Perish
Timelord
RIME
Deja Voodoo Spells
Marilisa
Roch Voisine Wazimba
Yannick Robert
3 Doors Down
Eternal Now
The Mars Volta
Dama Juana
The Casual's, Solo Artist
Alisa
Patrick Rondat, Elegy
Into Eternity
Melendi
Ida Landsberg Trio, Solo Artist
God Dethroned
Letzte Instanz
Crave
Nevio
John Scofield
Jeremiah Scott
Jake Scott
Arthur Seay
Roni Seppänen
Justin Shah
Justin Shekoski
Mike Shinoda
Tony Shoaf
Shave
Christoph Siemons
Dwight Sills
Alejandro Silva
Roger Sjunnesson
Terji Skibenaz
Michael Soibinen
Ralf Sommerfeld
Waldemar Soryccha
Felipe Souza
Chris Stalder
Pablo Stipicic
Benny Stock
Nita Strauss
Vince Stropi
Muhammed Suicmez
Rikard Sundén
Marcus Sunesson
Ken Susi
Tommy Sveta
Jon Symons
Vlad Tanaskovic
Jaime Teisere
Chris Telis
Seth Theaker
Bobby Thompson
Mick Thomson
Fredrik Thordendal
Frank Tijink
Andy Timmons
Tobias
Ton
Tora
Gisle Torvik
Sam Totman
Rares Totu
Koji Tsumoto
Olli Tuohimäen
Sébastien Turi
Dave Ulrich
U-Nam
Patrick Uterwijk
Ludovico Vagnone
Steve Vai
Javi Valero
Sander van der Meer
Chema Vilchez
Elias Viljanen
Tommy Vucur
Everton Waldman
Pop Warabit
Yu Watanabe
Bob Weir
Brian "Head" Welch
Oskar Montelius
Munky
Yasushi Muratori
Stephen Murphy
Kamal Musallam Group
Kristian Niemann
Johan Niemann
Per Nilsson
Noodles
Pekka Oikkonen
Magnus Olsson
Ben Orum
Jack Owen
David Palau
Rob Patterson
Pat Pattison
Pera
Zlatko "Slädu" Perica
Angelo Pierattini
Jürgen Plangger
Emil Pohjalainen
Benoit POL Group
Aria
Vanishing Point
Lucio Dalla
The Eyes Of A Traitor
Trigger The Bloodshed
Airless
Necrophagist
Saiko

August Burns Red
Jive Talking, Cradle
Draven
Red
Beverly Knight, Liberty X, Billy Crawford, Ms Dynamite
BLINDSPOTT
VVD
myGRAIN
Taproot
All Shall Perish
Timelord
RIME
Deja Voodoo Spells
Marilisa
Roch Voisine Wazimba
Yannick Robert
3 Doors Down
Eternal Now
The Mars Volta
Dama Juana
The Casual's, Solo Artist
Alisa
Patrick Rondat, Elegy
Into Eternity
Melendi
Ida Landsberg Trio, Solo Artist
God Dethroned
Letzte Instanz
Crave
Nevio
John Scofield
Jeremiah Scott
Jake Scott
Arthur Seay
Roni Seppänen
Justin Shah
Justin Shekoski
Mike Shinoda
Tony Shoaf
Shave
Christoph Siemons
Dwight Sills
Alejandro Silva
Roger Sjunnesson
Terji Skibenaz
Michael Soibinen
Ralf Sommerfeld
Waldemar Soryccha
Felipe Souza
Chris Stalder
Pablo Stipicic
Benny Stock
Nita Strauss
Vince Stropi
Muhammed Suicmez
Rikard Sundén
Marcus Sunesson
Ken Susi
Tommy Sveta
Jon Symons
Vlad Tanaskovic
Jaime Teisere
Chris Telis
Seth Theaker
Bobby Thompson
Mick Thomson
Fredrik Thordendal
Frank Tijink
Andy Timmons
Tobias
Ton
Tora
Gisle Torvik
Sam Totman
Rares Totu
Koji Tsumoto
Olli Tuohimäen
Sébastien Turi
Dave Ulrich
U-Nam
Patrick Uterwijk
Ludovico Vagnone
Steve Vai
Javi Valero
Sander van der Meer
Chema Vilchez
Elias Viljanen
Tommy Vucur
Everton Waldman
Pop Warabit
Yu Watanabe
Bob Weir
Brian "Head" Welch
Oskar Montelius
Munky
Yasushi Muratori
Stephen Murphy
Kamal Musallam Group
Kristian Niemann
Johan Niemann
Per Nilsson
Noodles
Pekka Oikkonen
Magnus Olsson
Ben Orum
Jack Owen
David Palau
Rob Patterson
Pat Pattison
Pera
Zlatko "Slädu" Perica
Angelo Pierattini
Jürgen Plangger
Emil Pohjalainen
Benoit POL Group
Aria
Vanishing Point
Lucio Dalla
The Eyes Of A Traitor
Trigger The Bloodshed
Airless
Necrophagist
Saiko

August Burns Red
Jive Talking, Cradle
Draven
Red
Beverly Knight, Liberty X, Billy Crawford, Ms Dynamite
BLINDSPOTT
VVD
myGRAIN
Taproot
All Shall Perish
Timelord
RIME
Deja Voodoo Spells
Marilisa
Roch Voisine Wazimba
Yannick Robert
3 Doors Down
Eternal Now
The Mars Volta
Dama Juana
The Casual's, Solo Artist
Alisa
Patrick Rondat, Elegy
Into Eternity
Melendi
Ida Landsberg Trio, Solo Artist
God Dethroned
Letzte Instanz
Crave
Nevio
John Scofield
Jeremiah Scott
Jake Scott
Arthur Seay
Roni Seppänen
Justin Shah
Justin Shekoski
Mike Shinoda
Tony Shoaf
Shave
Christoph Siemons
Dwight Sills
Alejandro Silva
Roger Sjunnesson
Terji Skibenaz
Michael Soibinen
Ralf Sommerfeld
Waldemar Soryccha
Felipe Souza
Chris Stalder
Pablo Stipicic
Benny Stock
Nita Strauss
Vince Stropi
Muhammed Suicmez
Rikard Sundén
Marcus Sunesson
Ken Susi
Tommy Sveta
Jon Symons
Vlad Tanaskovic
Jaime Teisere
Chris Telis
Seth Theaker
Bobby Thompson
Mick Thomson
Fredrik Thordendal
Frank Tijink
Andy Timmons
Tobias
Ton
Tora
Gisle Torvik
Sam Totman
Rares Totu
Koji Tsumoto
Olli Tuohimäen
Sébastien Turi
Dave Ulrich
U-Nam
Patrick Uterwijk
Ludovico Vagnone
Steve Vai
Javi Valero
Sander van der Meer
Chema Vilchez
Elias Viljanen
Tommy Vucur
Everton Waldman
Pop Warabit
Yu Watanabe
Bob Weir
Brian "Head" Welch
Oskar Montelius
Munky
Yasushi Muratori
Stephen Murphy
Kamal Musallam Group
Kristian Niemann
Johan Niemann
Per Nilsson
Noodles
Pekka Oikkonen
Magnus Olsson
Ben Orum
Jack Owen
David Palau
Rob Patterson
Pat Pattison
Pera
Zlatko "Slädu" Perica
Angelo Pierattini
Jürgen Plangger
Emil Pohjalainen
Benoit POL Group
Aria
Vanishing Point
Lucio Dalla
The Eyes Of A Traitor
Trigger The Bloodshed
Airless
Necrophagist
Saiko

August Burns Red
Jive Talking, Cradle
Draven
Red
Beverly Knight, Liberty X, Billy Crawford, Ms Dynamite
BLINDSPOTT
VVD
myGRAIN
Taproot
All Shall Perish
Timelord
RIME
Deja Voodoo Spells
Marilisa
Roch Voisine Wazimba
Yannick Robert
3 Doors Down
Eternal Now
The Mars Volta
Dama Juana
The Casual's, Solo Artist
Alisa
Patrick Rondat, Elegy
Into Eternity
Melendi
Ida Landsberg Trio, Solo Artist
God Dethroned
Letzte Instanz
Crave
Nevio
John Scofield
Jeremiah Scott
Jake Scott
Arthur Seay
Roni Seppänen
Justin Shah
Justin Shekoski
Mike Shinoda
Tony Shoaf
Shave
Christoph Siemons
Dwight Sills
Alejandro Silva
Roger Sjunnesson
Terji Skibenaz
Michael Soibinen
Ralf Sommerfeld
Waldemar Soryccha
Felipe Souza
Chris Stalder
Pablo Stipicic
Benny Stock
Nita Strauss
Vince Stropi
Muhammed Suicmez
Rikard Sundén
Marcus Sunesson
Ken Susi
Tommy Sveta
Jon Symons
Vlad Tanaskovic
Jaime Teisere
Chris Telis
Seth Theaker
Bobby Thompson
Mick Thomson
Fredrik Thordendal
Frank Tijink
Andy Timmons
Tobias
Ton
Tora
Gisle Torvik
Sam Totman
Rares Totu
Koji Tsumoto
Olli Tuohimäen
Sébastien Turi
Dave Ulrich
U-Nam
Patrick Uterwijk
Ludovico Vagnone
Steve Vai
Javi Valero
Sander van der Meer
Chema Vilchez
Elias Viljanen
Tommy Vucur
Everton Waldman
Pop Warabit
Yu Watanabe
Bob Weir
Brian "Head" Welch
Oskar Montelius
Munky
Yasushi Muratori
Stephen Murphy
Kamal Musallam Group
Kristian Niemann
Johan Niemann
Per Nilsson
Noodles
Pekka Oikkonen
Magnus Olsson
Ben Orum
Jack Owen
David Palau
Rob Patterson
Pat Pattison
Pera
Zlatko "Slädu" Perica
Angelo Pierattini
Jürgen Plangger
Emil Pohjalainen
Benoit POL Group
Aria
Vanishing Point
Lucio Dalla
The Eyes Of A Traitor
Trigger The Bloodshed
Airless
Necrophagist
Saiko

August Burns Red
Jive Talking, Cradle
Draven
Red
Beverly Knight, Liberty X, Billy Crawford, Ms Dynamite
BLINDSPOTT
VVD
myGRAIN
Taproot
All Shall Perish
Timelord
RIME
Deja Voodoo Spells
Marilisa
Roch Voisine Wazimba
Yannick Robert
3 Doors Down
Eternal Now
The Mars Volta
Dama Juana
The Casual's, Solo Artist
Alisa
Patrick Rondat, Elegy
Into Eternity
Melendi
Ida Landsberg Trio, Solo Artist
God Dethroned
Letzte Instanz
Crave
Nevio
John Scofield
Jeremiah Scott
Jake Scott
Arthur Seay
Roni Seppänen
Justin Shah
Justin Shekoski
Mike Shinoda
Tony Shoaf
Shave
Christoph Siemons
Dwight Sills
Alejandro Silva
Roger Sjunnesson
Terji Skibenaz
Michael Soibinen
Ralf Sommerfeld
Waldemar Soryccha
Felipe Souza
Chris Stalder
Pablo Stipicic
Benny Stock
Nita Strauss
Vince Stropi
Muhammed Suicmez
Rikard Sundén
Marcus Sunesson
Ken Susi
Tommy Sveta
Jon Symons
Vlad Tanaskovic
Jaime Teisere
Chris Telis
Seth Theaker
Bobby Thompson
Mick Thomson
Fredrik Thordendal
Frank Tijink
Andy Timmons
Tobias
Ton
Tora
Gisle Torvik
Sam Totman
Rares Totu
Koji Tsumoto
Olli Tuohimäen
Sébastien Turi
Dave Ulrich
U-Nam
Patrick Uterwijk
Ludovico Vagnone
Steve Vai
Javi Valero
Sander van der Meer
Chema Vilchez
Elias Viljanen
Tommy Vucur
Everton Waldman
Pop Warabit
Yu Watanabe
Bob Weir
Brian "Head" Welch
Oskar Montelius
Munky
Yasushi Muratori
Stephen Murphy
Kamal Musallam Group
Kristian Niemann
Johan Niemann
Per Nilsson
Noodles
Pekka Oikkonen
Magnus Olsson
Ben Orum
Jack Owen
David Palau
Rob Patterson
Pat Pattison
Pera
Zlatko "Slädu" Perica
Angelo Pierattini
Jürgen Plangger
Emil Pohjalainen
Benoit POL Group
Aria
Vanishing Point
Lucio Dalla
The Eyes Of A Traitor
Trigger The Bloodshed
Airless
Necrophagist
Saiko

August Burns Red
Jive Talking, Cradle
Draven
Red
Beverly Knight, Liberty X, Billy Crawford, Ms Dynamite
BLINDSPOTT
VVD
myGRAIN
Taproot
All Shall Perish
Timelord
RIME
Deja Voodoo Spells
Marilisa
Roch Voisine Wazimba
Yannick Robert
3 Doors Down
Eternal Now
The Mars Volta
Dama Juana
The Casual's, Solo Artist
Alisa
Patrick Rondat, Elegy
Into Eternity
Melendi
Ida Landsberg Trio, Solo Artist
God Dethroned
Letzte Instanz
Crave
Nevio
John Scofield
Jeremiah Scott
Jake Scott
Arthur Seay
Roni Seppänen
Justin Shah
Justin Shekoski
Mike Shinoda
Tony Shoaf
Shave
Christoph Siemons
Dwight Sills
Alejandro Silva
Roger Sjunnesson
Terji Skibenaz
Michael Soibinen
Ralf Sommerfeld
Waldemar Soryccha
Felipe Souza
Chris Stalder
Pablo Stipicic
Benny Stock
Nita Strauss
Vince Stropi
Muhammed Suicmez
Rikard Sundén
Marcus Sunesson
Ken Susi
Tommy Sveta
Jon Symons
Vlad Tanaskovic
Jaime Teisere
Chris Telis
Seth Theaker
Bobby Thompson
Mick Thomson
Fredrik Thordendal
Frank Tijink
Andy Timmons
Tobias
Ton
Tora
Gisle Torvik
Sam Totman
Rares Totu
Koji Tsumoto
Olli Tuohimäen
Sébastien Turi
Dave Ulrich
U-Nam
Patrick Uterwijk
Ludovico Vagnone
Steve Vai
Javi Valero
Sander van der Meer
Chema Vilchez
Elias Viljanen
Tommy Vucur
Everton Waldman
Pop Warabit
Yu Watanabe
Bob Weir
Brian "Head" Welch
Oskar Montelius
Munky
Yasushi Muratori
Stephen Murphy
Kamal Musallam Group
Kristian Niemann
Johan Niemann
Per Nilsson
Noodles
Pekka Oikkonen
Magnus Olsson
Ben Orum
Jack Owen
David Palau
Rob Patterson
Pat Pattison
Pera
Zlatko "Slädu" Perica
Angelo Pierattini
Jürgen Plangger
Emil Pohjalainen
Benoit POL Group
Aria
Vanishing Point
Lucio Dalla
The Eyes Of A Traitor
Trigger The Bloodshed
Airless
Necrophagist
Saiko

August Burns Red
Jive Talking, Cradle
Draven
Red
Beverly Knight, Liberty X, Billy Crawford, Ms Dynamite
BLINDSPOTT
VVD
myGRAIN
Taproot
All Shall Perish
Timelord
RIME
Deja Voodoo Spells
Marilisa
Roch Voisine Wazimba
Yannick Robert
3 Doors Down
Eternal Now
The Mars Volta
Dama Juana
The Casual's, Solo Artist
Alisa
Patrick Rondat, Elegy
Into Eternity
Melendi
Ida Landsberg Trio, Solo Artist
God Dethroned
Letzte Instanz
Crave
Nevio
John Scofield
Jeremiah Scott
Jake Scott
Arthur Seay
Roni Seppänen
Justin Shah
Justin Shekoski
Mike Shinoda
Tony Shoaf
Shave
Christoph Siemons
Dwight Sills
Alejandro Silva
Roger Sjunnesson
Terji Skibenaz
Michael Soibinen
Ralf Sommerfeld
Waldemar Soryccha
Felipe Souza
Chris Stalder
Pablo Stipicic
Benny Stock
Nita Strauss
Vince Stropi
Muhammed Suicmez
Rikard Sundén
Marcus Sunesson
Ken Susi
Tommy Sveta
Jon Symons
Vlad Tanaskovic
Jaime Teisere
Chris Telis
Seth Theaker
Bobby Thompson
Mick Thomson
Fredrik Thordendal
Frank Tijink
Andy Timmons
Tobias
Ton
Tora
Gisle Torvik
Sam Totman
Rares Totu
Koji Tsumoto
Olli Tuohimäen
Sébastien Turi
Dave Ulrich
U-Nam
Patrick Uterwijk
Ludovico Vagnone
Steve Vai
Javi Valero
Sander van der Meer
Chema Vilchez
Elias Viljanen
Tommy Vucur
Everton Waldman
Pop Warabit
Yu Watanabe
Bob Weir
Brian "Head" Welch
Oskar Montelius
Munky
Yasushi Muratori
Stephen Murphy
Kamal Musallam Group
Kristian Niemann
Johan Niemann
Per Nilsson
Noodles
Pekka Oikkonen
Magnus Olsson
Ben Orum
Jack Owen
David Palau
Rob Patterson
Pat Pattison
Pera
Zlatko "Slädu" Perica
Angelo Pierattini
Jürgen Plangger
Emil Pohjalainen
Benoit POL Group
Aria
Vanishing Point
Lucio Dalla
The Eyes Of A Traitor
Trigger The Bloodshed
Airless
Necrophagist
Saiko

August Burns Red
Jive Talking, Cradle
Draven
Red
Beverly Knight, Liberty X, Billy Crawford, Ms Dynamite
BLINDSPOTT
VVD
myGRAIN
Taproot
All Shall Perish
Timelord
RIME
Deja Voodoo Spells
Marilisa
Roch Voisine Wazimba
Yannick Robert
3 Doors Down
Eternal Now
The Mars Volta
Dama Juana
The Casual's, Solo Artist
Alisa
Patrick Rondat, Elegy
Into Eternity
Melendi
Ida Landsberg Trio, Solo Artist
God Dethroned
Letzte Instanz
Crave
Nevio
John Scofield
Jeremiah Scott
Jake Scott
Arthur Seay
Roni Seppänen
Justin Shah
Justin Shekoski
Mike Shinoda
Tony Shoaf
Shave
Christoph Siemons
Dwight Sills
Alejandro Silva
Roger Sjunnesson
Terji Skibenaz
Michael Soibinen
Ralf Sommerfeld
Waldemar Soryccha
Felipe Souza
Chris Stalder
Pablo Stipicic
Benny Stock
Nita Strauss
Vince Stropi
Muhammed Suicmez
Rikard Sundén
Marcus Sunesson
Ken Susi
Tommy Sveta
Jon Symons
Vlad Tanaskovic
Jaime Teisere
Chris Telis
Seth Theaker
Bobby Thompson
Mick Thomson
Fredrik Thordendal
Frank Tijink
Andy Timmons
Tobias
Ton
Tora
Gisle Torvik
Sam Totman
Rares Totu
Koji Tsumoto
Olli Tuohimäen
Sébastien Turi
Dave Ulrich
U-Nam
Patrick Uterwijk
Ludovico Vagnone
Steve Vai
Javi Valero
Sander van der Meer
Chema Vilchez
Elias Viljanen
Tommy Vucur
Everton Waldman
Pop Warabit
Yu Watanabe
Bob Weir
Brian "Head" Welch
Oskar Montelius
Munky
Yasushi Muratori
Stephen Murphy
Kamal Musallam Group
Kristian Niemann
Johan Niemann
Per Nilsson
Noodles
Pekka Oikkonen
Magnus Olsson
Ben Orum
Jack Owen
David Palau
Rob Patterson
Pat Pattison
Pera
Zlatko "Slädu" Perica
Angelo Pierattini
Jürgen Plangger
Emil Pohjalainen
Benoit POL Group
Aria
Vanishing Point
Lucio Dalla
The Eyes Of A Traitor
Trigger The Bloodshed
Airless
Necrophagist
Saiko

August Burns Red
Jive Talking, Cradle
Draven
Red
Beverly Knight, Liberty X, Billy Crawford, Ms Dynamite
BLINDSPOTT
VVD
myGRAIN
Taproot
All Shall Perish
Timelord
RIME
Deja Voodoo Spells
Marilisa
Roch Voisine Wazimba
Yannick Robert
3 Doors Down
Eternal Now
The Mars Volta
Dama Juana
The Casual's, Solo Artist
Alisa
Patrick Rondat, Elegy
Into Eternity
Melendi
Ida Landsberg Trio, Solo Artist
God Dethroned
Letzte Instanz
Crave
Nevio
John Scofield
Jeremiah Scott
Jake Scott
Arthur Seay
Roni Seppänen
Justin Shah
Justin Shekoski
Mike Shinoda
Tony Shoaf
Shave
Christoph Siemons
Dwight Sills
Alejandro Silva
Roger Sjunnesson
Terji Skibenaz
Michael Soibinen
Ralf Sommerfeld
Waldemar Soryccha
Felipe Souza
Chris Stalder
Pablo Stipicic
Benny Stock
Nita Strauss
Vince Stropi
Muhammed Suicmez
Rikard Sundén
Marcus Sunesson
Ken Susi
Tommy Sveta
Jon Symons
Vlad Tanaskovic
Jaime Teisere
Chris Telis
Seth Theaker
Bobby Thompson
Mick Thomson
Fredrik Thordendal
Frank Tijink
Andy Timmons
Tobias
Ton
Tora
Gisle Torvik
Sam Totman
Rares Totu
Koji Tsumoto
Olli Tuohimäen
Sébastien Turi
Dave Ulrich
U-Nam
Patrick Uterwijk
Ludovico Vagnone
Steve Vai
Javi Valero
Sander van der Meer
Chema Vilchez
Elias Viljanen
Tommy Vucur
Everton Waldman
Pop Warabit
Yu Watanabe
Bob Weir
Brian "Head" Welch
Oskar Montelius
Munky
Yasushi Muratori
Stephen Murphy
Kamal Musallam Group
Kristian Niemann
Johan Niemann
Per Nilsson
Noodles
Pekka Oikkonen
Magnus Olsson
Ben Orum
Jack Owen
David Palau
Rob Patterson
Pat Pattison
Pera
Zlatko "Slädu" Perica
Angelo Pierattini
Jürgen Plangger
Emil Pohjalainen
Benoit POL Group
Aria
Vanishing Point
Lucio Dalla
The Eyes Of A Traitor
Trigger The Bloodshed
Airless
Necrophagist
Saiko

August Burns Red
Jive Talking, Cradle
Draven
Red
Beverly Knight, Liberty X, Billy Crawford, Ms Dynamite
BLINDSPOTT
VVD
myGRAIN
Taproot
All Shall Perish
Timelord
RIME
Deja Voodoo Spells
Marilisa
Roch Voisine Wazimba
Yannick Robert
3 Doors Down
Eternal Now
The Mars Volta
Dama Juana
The Casual's, Solo Artist
Alisa
Patrick Rondat, Elegy
Into Eternity
Melendi
Ida Landsberg Trio, Solo Artist
God Dethroned
Letzte Instanz
Crave
Nevio
John Scofield
Jeremiah Scott
Jake Scott
Arthur Seay
Roni Seppänen
Justin Shah
Justin Shekoski
Mike Shinoda
Tony Shoaf
Shave
Christoph Siemons
Dwight Sills
Alejandro Silva
Roger Sjunnesson
Terji Skibenaz
Michael Soibinen

A great live sound is the result of hard work - from the decisions that go into developing and refining it, all the way to the experience it takes to successfully reproduce it night after night. It's also a result of choosing the right gear. Gear that sounds the way you need it to - consistently, dependably, affordably.

Here at Ibanez we understand what it takes to build great sounding gear. We work closely with the artists that use our products every day to make sure we stay on top of the changing needs of modern musicians. We see it as our job to produce relevant, affordable solutions for every application.

Allow us to welcome you to our 2010 catalog and invite you to take a look around. As you flip through it's pages, you may be surprised at how many of your favorite artists are using Ibanez. Oh, and while you're here, be sure to check out the RGA series electric guitars. With active pickups, active eq, and a new arched top design, these lightweight axes are a pleasure to play and offer nearly unlimited tonal possibilities.

Seeking something heavy? The RGD series is literally made for you. These guitars, including a 7-string model, are actually designed for down-tuning. The days of floppy strings are officially over. Let a new era of speed, accuracy, and sonic brutality begin!

Great tone starts with great gear. Shape yours with Ibanez!

Table of Contents

Solid Body Electric Guitars

Prestige.....	4
RGA Prestige.....	5
RGA.....	6-7
RGD.....	8-9
RG Prestige.....	10-13
RG TREMOLO.....	14
RG FIXED.....	15
GRG.....	16-17
S Prestige.....	18
S.....	19
FR Prestige.....	20

SV Prestige.....	21
SA.....	22-23
DN.....	24-25
ART.....	26-27
X.....	28-29
AR/GAX.....	30
JTK.....	31
JS.....	32-33
JEM/UV.....	34-35
EGEN/STM.....	36
MTM/MBM.....	37
PGM/AT/NDM.....	38

APEX/ORM.....	39
Hollow Body Guitars & Bases	
GB/PM/JSM.....	40-41
AF.....	42-43
AK/AG/AFS.....	44-45
AS/AMF.....	46-47
Electric Bases	
SR Prestige.....	50-51
SR.....	52-54
EDB.....	55
GSR.....	56-57
SRX/ICB.....	58-59

BTB.....	60-61
ATK.....	62
JTKB.....	63
ARTB/AFB/AGB.....	64
GWB/K5.....	65
PGB/MDB.....	66
PRB/SDB/PIB.....	67
Jumpstart.....	68-69
Amplifiers	
Promethean.....	72-73
SWX.....	74
Troubadour.....	75

Tone Blaster X.....	76
MIMX.....	77
Effects	
JEMINI/TK.....	78
AF2/WD/WH.....	79
TS808 & 9series.....	80
TONE-LOK.....	81
Accessories	
Desktop Amps.....	82
Tuners.....	83
Cables.....	84
Straps.....	85

Bags.....	86-87
Cases.....	88
Guitar Stands/Pick Holder.....	89
Picks.....	90
Guitar/Bass Bridges.....	92-93
Bass Electronics.....	94
Pickup Characters.....	95
Pickup Layout.....	96
Neck Dimensions.....	97
Finishes.....	98-99



Prestige

Precision, Performance and Playability.

Everything you've ever dreamed of in a guitar or bass.

These are 3 principles behind our new Ibanez Prestige line.

Combining high tech manufacturing techniques with old world craftsmanship, true innovation in design and construction and the incorporation of ideas and

suggestions from musicians from around the world are cornerstones of the Prestige production process.

Precision

High tech manufacturing techniques allow the highest levels of precision in terms of ensuring the tightest tolerances in wood work, paint and hardware design and construction.



Neck Joint

All Prestige models are "Made in Japan" with the finest Ibanez craftsmanship.

Performance

Ibanez guitars have always been known for their high performance fast necks, optimized pickups and electronics and advanced bridges and hardware. With Prestige, all of these components are continually tweaked and taken to the cutting edge.



Hardware

Originally designed Ibanez hardware and parts, from bridge and pickups to nut, built to work together precisely.

Playability

All of this means nothing without supreme playability. Years of research and testing out in the field with artists all over the world helped us to develop the three distinctively unique high performance neck shapes for electric guitar and one for bass. In the Prestige line, there is now a perfect neck shape for every type of player. The Super Wizard HP, Wizard HP and ULTRA HP for guitar and ATLAS HP neck for bass.

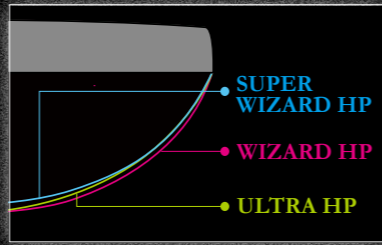

Neck Shape

Each series of Prestige features the best suited neck shape for the player's tastes.

RGA *Prestige*

CRAFTED BY JAPAN'S FINEST LUTHIERS

The RGA archtop guitar not only has curves but playability. And for live performance, its lightweight body gives players more freedom to move on stage. The arched top also allows players to knock down heavy riffs and power chords without hitting the guitar body. Curved beauty and great performance combine gracefully in the RGA.

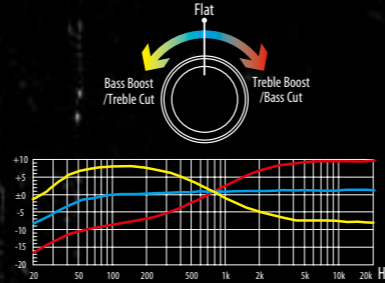

RGA Active EQ

This EQ allows for everything from massive fat low tones to sharp treble tones through the turn of one knob with almost no change in output volume. The tone changes in a smooth and natural curve, so it's easy and quick to find the sound you're looking for.



LZ4 Pickups

The LZ4 is an original Ibanez active pickup with a wide dynamic range. It produces powerful and clear humbucker sound with low noise.



Chris Broderick

Megadeth

phot by David Hall



RGA427Z DSH

- 5pc Wizard-7 Maple /Wenge neck *Prestige*
- Flamed Maple top/Mahogany body
- Jumbo frets
- Edge-Zero 7 bridge w/ZPS3
- LZ7 (H) neck pu
- LZ7 (H) bridge pu
- Hardware color : Cosmo Black
- Scale : 648mm/25.5"
- Color : DSH (Devil's Shadow)

RGA420Z PRT

- 5pc Wizard HP Maple /Walnut neck *Prestige*
- Flamed Maple top /Mahogany body
- Jumbo frets
- Edge-Zero bridge w/ZPS3
- LZ4 (H) neck pu
- LZ4 (H) bridge pu
- Hardware color : Cosmo Black
- Scale : 648mm/25.5"
- Color : PRT (Predator's Tongue)



RGA220Z CYB

- 5pc Wizard HP Maple /Walnut neck *Prestige*
- Mahogany body
- Jumbo frets
- Edge-Zero bridge w/ZPS3
- LZ4-N (H) neck pu
- LZ4-B (H) bridge pu
- Hardware color : Cosmo Black
- Scale : 648mm/25.5"
- Colors : CYB (Crystal Black) CYW (Crystal Wine)



Special Horn Cut

The extra horn cut on the RGA Prestige allows even easier upper fret access than the deep cutaway on the classic RG.

RGA220Z CYW

- 5pc Wizard HP Maple /Walnut neck *Prestige*
- Mahogany body
- Jumbo frets
- Edge-Zero bridge w/ZPS3
- LZ4-N (H) neck pu
- LZ4-B (H) bridge pu
- Hardware color : Cosmo Black
- Scale : 648mm/25.5"
- Colors : CYB (Crystal Black) CYW (Crystal Wine)

RGAs



RGAs72QM TLB

- 3pc Wizard II Maple set-in neck w/KTS™ TITANIUM Reinforcement
- Quilted Maple top/Mahogany body
- Jumbo frets
- Gibraltar Standard bridge
- LZ3-N (H) neck pu
- LZ3-B (H) bridge pu
- Hardware color : Cosmo Black
- Scale : 648mm/25.5"
- Color : TLB (Transparent Lavender Burst)

RGAs72TQM TGB

- 3pc Wizard II Maple set-in neck w/KTS™ TITANIUM Reinforcement
- Quilted Maple top/Mahogany body
- Jumbo frets
- Edge III bridge
- LZ3-N (H) neck pu
- LZ3-B (H) bridge pu
- Hardware color : Cosmo Black
- Scale : 648mm/25.5"
- Color : TGB (Transparent Gray Burst)



LZ3 Pickups

The LZ3 is also an original Ibanez active pickup, but with higher output than the LZ4. It produces a fat sound with good clarity perfect for distortion sounds.

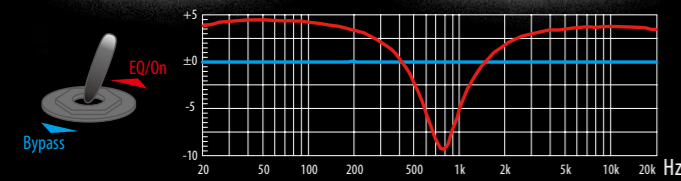

RGAs Active EQ

Specially designed to function with the fat and strong LZ3 pickups, the output is controlled by an active circuit to provide pure tone free of noise.

Brian Leppke
Bleeding Through



FX EDGE III-8 Bridge

Ibanez FX EDGE III-8 double-locking fixed bridge was made specifically to handle and augment the awesome extended range of the RGA8 8-string.



Gibraltar Standard Bridge

The Gibraltar Standard is a simple fixed bridge that was designed to adhere firmly to the guitar body and make good transfer of the string vibrations. It is also incredibly smooth for maximum playing comfort.

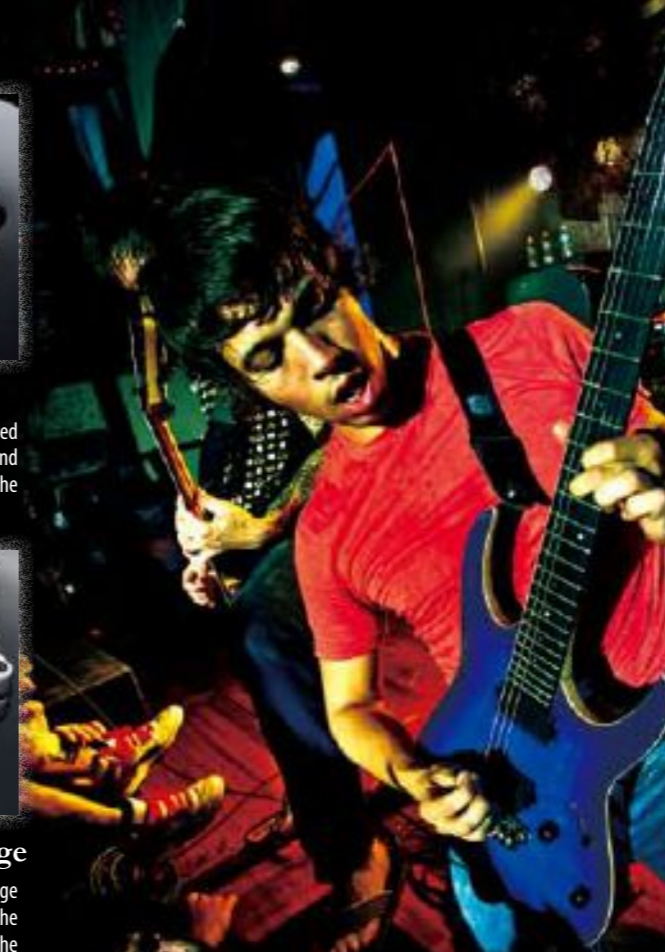

JB Brubaker
August Burns Red
Photo by Cory Morton



RGAs32 WH

- 3pc Wizard II Maple neck
- Mahogany body
- Jumbo frets
- Gibraltar Standard bridge
- LZ3-N (H) neck pu
- LZ3-B (H) bridge pu
- Hardware color : Cosmo Black
- Scale : 648mm/25.5"
- Colors : MOL (Mahogany Oil) WH (White)



RGAs42T BK

- 3pc Wizard II Maple neck
- Mahogany body
- Jumbo frets
- Edge III bridge
- LZ3-N (H) neck pu
- LZ3-B (H) bridge pu
- Hardware color : Cosmo Black
- Scale : 648mm/25.5"
- Color : BK (Black)



RGAs42 BK

- 3pc Wizard II Maple neck
- Mahogany body
- Jumbo frets
- Gibraltar Standard bridge
- LZ3-N (H) neck pu
- LZ3-B (H) bridge pu
- Hardware color : Cosmo Black
- Scale : 648mm/25.5"
- Color : BK (Black)



RGAs8 BK

- 5pc Wizard II-8 Maple/Walnut neck w/KTS™ TITANIUM Reinforcement
- Mahogany body
- Jumbo frets
- Fixed Edge III-8 bridge
- LZ8-N (H) neck pu
- LZ8-B (H) bridge pu
- Hardware color : Black
- Scale : 685.8mm/27"
- Color : BK (Black)



RGAs7 BK

- 5pc Wizard II-7 Maple/Walnut neck
- Mahogany body
- Jumbo frets
- Gibraltar Standard-7 bridge
- LZ7-N (H) neck pu
- LZ7-B (H) bridge pu
- Hardware color : Cosmo Black
- Scale : 648mm/25.5"
- Color : BK (Black)



RGAs32 MOL

- 3pc Wizard II Maple neck
- Mahogany body
- Jumbo frets
- Gibraltar Standard bridge
- LZ3-N (H) neck pu
- LZ3-B (H) bridge pu
- Hardware color : Cosmo Black
- Scale : 648mm/25.5"
- Colors : MOL (Mahogany Oil) WH (White)

Mark Jansen
Epica

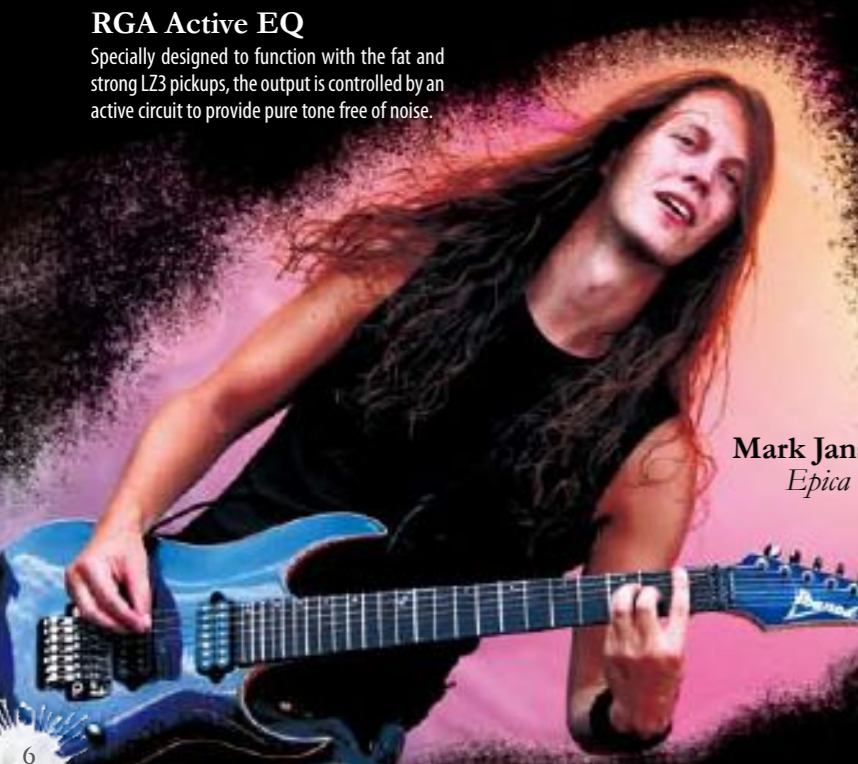

Brent Rambler
August Burns Red

RGD *Prestige*

CRAFTED BY JAPAN'S FINEST LUTHIERS

As a pioneer of heavy rock guitars, Ibanez has released 7- and 8-string models in the past. This year we release the RGD, Ibanez's new heavy metal machine.

Heavy rock guitars are required to output clear sound down to the lowest note without losing playability. So we kept the neck scale to a 1-inch minimum between frets, and original tuned pickups are mounted.

Heavy rock guitarists usually hold their guitars low, and the sharp-shaped RGD body achieves good balance and easier access to high frets for low-slung players.



RGD2120Z CSM

- 5pc Wizard HP Maple/Walnut neck *Prestige*
- w/KTS™ TITANIUM Reinforcement
- Basswood body
- Jumbo frets
- Edge-Zero bridge w/ZPS3
- V7 Custom (H) neck pu
- V8 Custom (H) bridge pu
- Hardware color : Cosmo Black
- Scale : 672mm/26.5"
- Factory tuning : 1D, 2A, 3F, 4C, 5G, 6D
- String gauge : .010/ .013/ .017/ .026/ .036/ .046
- Color : CSM (Cobweb Silver Metallic)



RGD2127Z ISH

- 5pc Wizard-7 Maple/Wenge neck *Prestige*
- w/KTS™ TITANIUM Reinforcement
- Basswood Body
- Jumbo frets
- Edge-Zero 7 bridge w/ZPS3
- V77 Custom (H) neck pu
- V87 Custom (H) bridge pu
- Hardware color : Cosmo Black
- Scale : 672mm/26.5"
- Factory tuning : 1D, 2A, 3F, 4C, 5G, 6D, 7A
- String gauge : .010/ .013/ .017/ .026/ .036/ .046/ .054
- Color : ISH (Invisible Shadow)



RGD320 MGS

- 3pc Wizard II Maple neck
- Basswood body
- Jumbo frets
- Edge III bridge
- VK1-DT (H) neck pu
- VK2-DT (H) bridge pu
- Hardware color : Black
- Scale : 672mm/26.5"
- Factory tuning : 1D, 2A, 3F, 4C, 5G, 6D
- String gauge : .010/ .013/ .017/ .026/ .036/ .046
- Colors : MGS (Metallic Gray Sunburst)
- WH (White)

The VK-Down Tunz pickups

The VK-Down Tunz pickups for RGD320 feature alnico V bar polepieces, which will deliver high output with high-end clarity.



RGD320 WH

- 3pc Wizard II Maple neck
- Basswood body
- Jumbo frets
- Edge III bridge
- VK1-DT (H) neck pu
- VK2-DT (H) bridge pu
- Hardware color : Black
- Scale : 672mm/26.5"
- Factory tuning : 1D, 2A, 3F, 4C, 5G, 6D
- String gauge : .010/ .013/ .017/ .026/ .036/ .046
- Colors : MGS (Metallic Gray Sunburst)
- WH (White)



New Pickups for RGD

The V7/V8 Custom pickups on RGD Prestige models were specially designed and tuned for capturing more low-end, by regenerating a wider tonal range. Instead of losing the low-end, they output it with a rich, harmonic tone.

ALL Prestige features

Prestige Precision, Performance and Playability.
Everything you've ever dreamed of in a guitar or bass.



Collet Knob

Designed for great looks and engineered to avoid the risk of coming off while you're playing. The non-slip functionality gives this collet knob accurate axis rotation and control for any player.



Tool

The all-purpose maintenance tool is included with all Prestige models.



RGD/Special Horn Cut

The RGD offers ultimate playability, with a beveled body cut for extreme shredding and rifting, and extra horn cut for lightning fast upper fret access.

RG *Prestige*

CRAFTED BY JAPAN'S FINEST LUTHIERS

The RG is the most recognizable and distinctive guitar in the Ibanez line. Forged in the fires of 80's metal, this high-performance machine was built with speed and strength in mind. Whether using a locking tremolo with a sharp action knife edge or a hard tail bridge, the RG is a precision instrument.



DiMarzio® Pickups

The RG3570Z and RG3550MZ also feature the DiMarzio® Tone Zone® in the bridge position, True Velvet™ in the middle position, and the Air Norton™ in the neck position. With colored bobbins, these pickups add the flair of the 80's music scene to these modern designs.

RG Prestige /Super Wizard HP Neck

Refined super-fast Prestige Wizard neck for ultimate shredders – 17mm width at 1st fret and 19mm at the 12th.

RG3550MZ GK

- 5pc Super Wizard HP Maple/Walnut neck *Prestige* w/KTS™ TITANIUM Reinforcement
- Basswood body
- Jumbo frets
- Edge-Zero bridge w/ZPS3
- DiMarzio® Air Norton™ (H) neck pu
- DiMarzio® True Velvet™ (S) mid pu
- DiMarzio® Tone Zone® (H) bridge pu
- Hardware color : Cosmo Black
- Scale : 648mm/25.5"
- Colors : GK (Galaxy Black)
DY (Desert Sun Yellow)

RG3550MZ DY

- 5pc Super Wizard HP Maple/Walnut neck *Prestige* w/KTS™ TITANIUM Reinforcement
- Basswood body
- Jumbo frets
- Edge-Zero bridge w/ZPS3
- DiMarzio® Air Norton™ (H) neck pu
- DiMarzio® True Velvet™ (S) mid pu
- DiMarzio® Tone Zone® (H) bridge pu
- Hardware color : Cosmo Black
- Scale : 648mm/25.5"
- Colors : GK (Galaxy Black)
DY (Desert Sun Yellow)



RG2570MZ CAB

- 5pc Wizard HP Maple /Walnut neck *Prestige*
- Basswood body
- Jumbo frets
- Edge-Zero bridge w/ZPS3
- DiMarzio® IBZ-N (H) neck pu
- DiMarzio® IBZ-S (S) mid pu
- DiMarzio® IBZ-B (H) bridge pu
- Hardware color : Cosmo Black
- Scale : 648mm/25.5"
- Color : CAB (Caribbean Blue Lagoon)

RG2570Z DSP

- 5pc Wizard HP Maple /Walnut neck *Prestige*
- Basswood body
- Jumbo frets
- Edge-Zero bridge w/ZPS3
- DiMarzio® IBZ-N (H) neck pu
- DiMarzio® IBZ-S (S) mid pu
- DiMarzio® IBZ-B (H) bridge pu
- Hardware color : Cosmo Black
- Scale : 648mm/25.5"
- Colors : MCR (Mediterranean Coral Reef)
DSP (Dark Space)

RG2570Z MCR

- 5pc Wizard HP Maple /Walnut neck *Prestige*
- Basswood body
- Jumbo frets
- Edge-Zero bridge w/ZPS3
- DiMarzio® IBZ-N (H) neck pu
- DiMarzio® IBZ-S (S) mid pu
- DiMarzio® IBZ-B (H) bridge pu
- Hardware color : Cosmo Black
- Scale : 648mm/25.5"
- Colors : MCR (Mediterranean Coral Reef)
DSP (Dark Space)

RG Prestige /Wizard HP Neck

Refined fast Prestige Wizard neck offers better grip, feel and tone – 18mm width at 1st fret and 20mm at the 12th.

RG3570Z LB

- 5pc Super Wizard HP Maple/Walnut neck *Prestige* w/KTS™ TITANIUM Reinforcement
- Basswood body
- Jumbo frets
- Edge-Zero bridge w/ZPS3
- DiMarzio® Air Norton™ (H) neck pu
- DiMarzio® True Velvet™ (S) mid pu
- DiMarzio® Tone Zone® (H) bridge pu
- Hardware color : Cosmo Black
- Scale : 648mm/25.5"
- Color : LB (Laser Blue)

RG4570Z HBK

- 5pc Ultra HP Maple/Walnut neck *Prestige* w/KTS™ TITANIUM Reinforcement
- Flamed Maple top/Mahogany body
- Jumbo frets
- Edge-Zero bridge w/ZPS3
- DiMarzio® Air Norton™ (H) neck pu
- DiMarzio® True Velvet™ (S) mid pu
- DiMarzio® Tone Zone® (H) bridge pu
- Hardware color : Cosmo Black
- Scale : 648mm/25.5"
- Color : HBK (Himalayan Black)

RG Prestige/Ultra HP Neck

Ball-milled new Ultra HP neck gives fast yet full grip feel for more versatile players – 18mm width at 1st fret and 20mm at the 12th.

Dexter Holland
The Offspring



Justin Shekoski
Saosin



RG2550Z GW

- 5pc Wizard HP Maple /Walnut neck *Prestige*
- Basswood body
- Jumbo frets
- Edge-Zero bridge w/ZPS3
- DiMarzio® IBZ-N (H) neck pu
- DiMarzio® IBZ-S (S) mid pu
- DiMarzio® IBZ-B (H) bridge pu
- Hardware color : Cosmo Black
- Scale : 648mm/25.5"
- Colors : GK (Galaxy Black)
GW (Galaxy White)

RG2550Z GK

- 5pc Wizard HP Maple /Walnut neck *Prestige*
- Basswood body
- Jumbo frets
- Edge-Zero bridge w/ZPS3
- DiMarzio® IBZ-N (H) neck pu
- DiMarzio® IBZ-S (S) mid pu
- DiMarzio® IBZ-B (H) bridge pu
- Hardware color : Cosmo Black
- Scale : 648mm/25.5"
- Colors : GK (Galaxy Black)
GW (Galaxy White)



Ryan Knight
The Black Dahlia Murder



RG *Prestige*

CRAFTED BY JAPAN'S FINEST LUTHIERS



RG1570Z LMR

- 5pc Wizard HP Maple/Walnut neck *Prestige*
- Basswood body
- Jumbo frets
- Edge-Zero bridge w/ZPS3
- V7 (H) neck pu
- S1 (S) mid pu
- V8 (H) bridge pu
- Hardware color : Cosmo Black
- Scale : 648mm/25.5"
- Colors : BK (Black)
- JB (Jewel Blue)
- LMR (Liquid Metal Red)



RG1570Z JB

- 5pc Wizard HP Maple/Walnut neck *Prestige*
- Basswood body
- Jumbo frets
- Edge-Zero bridge w/ZPS3
- V7 (H) neck pu
- S1 (S) mid pu
- V8 (H) bridge pu
- Hardware color : Cosmo Black
- Scale : 648mm/25.5"
- Colors : BK (Black)
- JB (Jewel Blue)
- LMR (Liquid Metal Red)



RG1570Z BK

- 5pc Wizard HP Maple/Walnut neck *Prestige*
- Basswood body
- Jumbo frets
- Edge-Zero bridge w/ZPS3
- V7 (H) neck pu
- S1 (S) mid pu
- V8 (H) bridge pu
- Hardware color : Cosmo Black
- Scale : 648mm/25.5"
- Colors : BK (Black)
- JB (Jewel Blue)
- LMR (Liquid Metal Red)



RG1550MZ BK

- 5pc Wizard HP Maple /Walnut neck *Prestige*
- Basswood body
- Jumbo frets
- Edge-Zero bridge w/ZPS3
- V7 (H) neck pu
- S1 (S) mid pu
- V8 (H) bridge pu
- Hardware color : Cosmo Black
- Scale : 648mm/25.5"
- Color : BK (Black)



Jesse Ketive
Emmure



V7/S1/V8 Pickup

The RG1570Z/RG1550MZ can dial in any tone, from crystal clear to searing and nasty, thanks to its V7 neck pickup, S1 middle pickup and V8 bridge pickup combination.



Edge-Zero Tremolo

The Edge-Zero has a sharp knife-edge for extremely accurate tremolo playing. This tremolo also uses Ibanez innovations to keep string action constant and the bridge surface smooth. The specially designed arm socket prevents unnecessary wobble from the arm while providing full control over the arm's torque.



Mårten Hagström
Mesuggab

FX EDGE III-8 Bridge

Ibanez FX EDGE III-8 double-locking fixed bridge was made specifically to handle and augment the awesome extended range of the RG2228GK 8-string.



EMG® 808 Pickups

The U.S.A.-made EMG® 808 active pickups—the first ever full-production 8-string pickups.

RG2228 GK

- 5pc Ultra-8 Maple/Wenge neck *Prestige*
- w/KTS™ TITANIUM Reinforcement
- Basswood body
- Jumbo frets
- FX EDGE III-8 bridge
- EMG® 808 (H) neck pu
- EMG® 808 (H) bridge pu
- Hardware color : Black
- Scale : 685.8mm/27"
- Factory Tuning : 1D#, 2A#, 3F#, 4C#, 5G#, 6D#, 7A#, 8F
- String Gauge : .009/ .011/ .016/ .024/ .032/ .042/ .054/ .065
- Color : GK (Galaxy Black)



Fredrik Thordendal
Mesuggab



RG1527Z BK

- 5pc Wizard-7 Maple /Wenge neck *Prestige*
- Basswood body
- Jumbo frets
- Edge-Zero 7 bridge w/ZPS3
- V77 (H) neck pu
- V87 (H) bridge pu
- Hardware color : Cosmo Black
- Scale : 648mm/25.5"
- Color : BK (Black)



RG1451 NC

- 5pc Wizard HP Maple /Walnut neck *Prestige*
- Basswood body
- Jumbo frets
- Tight-End bridge
- V6F (H) neck pu
- RTS (S) mid pu
- V6F2 (H) bridge pu
- Hardware color : Cosmo Black
- Scale : 648mm/25.5"
- Colors : WHP (White Plaster) NC (Night Crow)



RG1451 WHP

- 5pc Wizard HP Maple /Walnut neck *Prestige*
- Basswood body
- Jumbo frets
- Tight-End bridge
- V6F (H) neck pu
- RTS (S) mid pu
- V6F2 (H) bridge pu
- Hardware color : Cosmo Black
- Scale : 648mm/25.5"
- Colors : WHP (White Plaster) NC (Night Crow)

RG TREMOLO

RG Tremolo models stand up to the most abusive whammy bar users around, while still maintaining perfect tuning stability. Lightning fast fretboard work is no problem with the Wizard neck, flat fingerboard and jumbo frets.

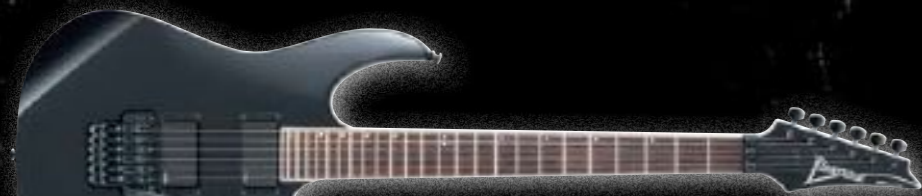

RGT6EX IPT

- 5pc Wizard II Maple/Walnut neck-thru w/KTS™ TITANIUM Reinforcement
- Mahogany wing body
- Jumbo frets
- Edge III bridge
- EMG® 85 (H) neck pu
- EMG® 81 (H) bridge pu
- Hardware color: Black
- Scale: 648mm/25.5"
- Color: IPT (Iron Pewter)

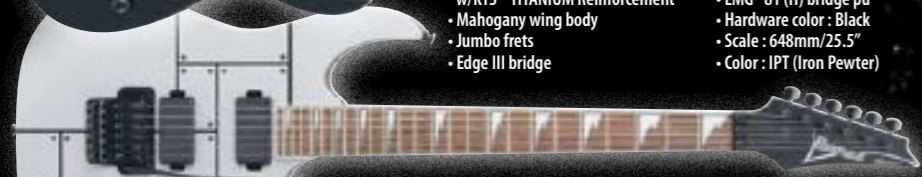

RG420EG ISL

- 3pc Wizard II Maple neck
- Basswood body
- Jumbo frets
- Edge III bridge
- V7 (H) neck pu
- V8 (H) bridge pu
- Hardware color: Black
- Scale: 648mm/25.5"
- Color: ISL (Iron Silver)



RG370DX BK

- 3pc Wizard II Maple neck
- Basswood body
- Jumbo frets
- Edge III bridge
- INF3 (H) neck pu
- INF3 (S) mid pu
- INF4 (H) bridge pu
- Hardware color: Black
- Scale: 648mm/25.5"
- Color: BK (Black)



Neck-Thru Construction

Neck-thru construction on the RGT provides massive sustain and playing comfort.



EMG® 81/85

The RGT6EX, RGT6EXFX feature EMG® 81/85 active pickups.

Edge III Tremolo

Ibanez has long been admired for the Edge tremolo, and the Edge III embodies all of the classic function of the original Edge with some modern updates. It features lower profile fine-tuners, much like the Lo-Pro Edge. There are also two screws in the arm pocket for easy adjustment of the arm height and torque.



Justin Lowe
After the Burial

RG370DXL BK

- Left-handed
- 3pc Wizard II Maple neck
- Basswood body
- Jumbo frets
- Edge III bridge
- INF3 (H) neck pu
- INF3 (S) mid pu
- INF4 (H) bridge pu
- Hardware color: Black
- Scale: 648mm/25.5"
- Color: BK (Black)



RG420FB NBF

- 3pc Wizard II Maple neck
- Mahogany body
- Jumbo frets
- Edge III bridge
- INF1 (H) neck pu
- INF2 (H) bridge pu
- Hardware color: Cosmo Black
- Scale: 648mm/25.5"
- Color: NBF (Natural Brown Burst Flat)



RG350DX WH

- 3pc Wizard II Maple neck
- Basswood body
- Jumbo frets
- Edge III bridge
- INF3 (H) neck pu
- INF3 (S) mid pu
- INF4 (H) bridge pu
- Hardware color: Black
- Scale: 648mm/25.5"
- Color: WH (White)

RG350EX BK

- 3pc Wizard II Maple neck
- Basswood body
- Jumbo frets
- Edge III bridge
- INF3 (H) neck pu
- INF3 (S) mid pu
- INF4 (H) bridge pu
- Hardware color: Cosmo Black
- Scale: 648mm/25.5"
- Color: BK (Black)

RG350M YE

- 3pc Wizard II Maple neck
- Basswood body
- Jumbo frets
- Edge III bridge
- INF3 (H) neck pu
- INF3 (S) mid pu
- INF4 (H) bridge pu
- Hardware color: Black
- Scale: 648mm/25.5"
- Colors: BK (Black)
- YE (Yellow)



Trent Haf Dahl
After the Burial



RG350M BK

- 3pc Wizard II Maple neck
- Basswood body
- Jumbo frets
- Edge III bridge
- INF3 (H) neck pu
- INF3 (S) mid pu
- INF4 (H) bridge pu
- Hardware color: Black
- Scale: 648mm/25.5"
- Colors: BK (Black)
- YE (Yellow)

RG FIXED

Sometimes keeping things simple is the way to go. The RG Fixed series is for players who prefer a straightforward fixed bridge setup.



Tony MacAlpine
Planet X



RGT6EXFX BK

- 5pc Wizard II Maple/Walnut neck-thru w/KTS™ TITANIUM Reinforcement
- Mahogany wing body
- Jumbo frets
- Gibraltar Standard bridge
- EMG® 85 (H) neck pu
- EMG® 81 (H) bridge pu
- Hardware color: Black
- Scale: 648mm/25.5"
- Color: BK (Black)

RGR321EX BK

- 3pc Wizard II Maple neck
- Basswood body
- Jumbo frets
- Gibraltar Standard bridge
- INF1 (H) neck pu
- INF2 (H) bridge pu
- Hardware color: Black
- Scale: 648mm/25.5"
- Color: BK (Black)

Bobby Thompson
Job For A Cowboy

Terry Balsamo
Evanescence

GRG

A guitar doesn't have to cost a bundle to sound good. The GIO series was developed for players who want Ibanez quality in a more affordable package. Ibanez now features the GRGR121EX, which was specially designed for metal players.

Ihsahn
Ihsahn, Emperor

GRGR121EX WH

- GRG1 Maple neck
- Basswood body
- Medium frets
- Fixed bridge
- PSND3 (H) neck pu
- PSND4 (H) bridge pu
- Hardware color : Black
- Scale : 648mm/25.5"
- Colors : BKN (Black Night)
CA (Candy Apple)
WH (White)

GRGR121EX CA

- GRG1 Maple neck
- Basswood body
- Medium frets
- Fixed bridge
- PSND3 (H) neck pu
- PSND4 (H) bridge pu
- Hardware color : Black
- Scale : 648mm/25.5"
- Colors : BKN (Black Night)
CA (Candy Apple)
WH (White)

GRGR121EX BKN

- GRG1 Maple neck
- Basswood body
- Medium frets
- Fixed bridge
- PSND3 (H) neck pu
- PSND4 (H) bridge pu
- Hardware color : Black
- Scale : 648mm/25.5"
- Colors : BKN (Black Night)
CA (Candy Apple)
WH (White)

GRG250DX BKF

- GRG2 Maple neck
- Basswood body
- Medium frets
- Edge III bridge
- PSND1 (H) neck pu
- PSNDS (S) mid pu
- PSND2 (H) bridge pu
- Hardware color : Black
- Scale : 648mm/25.5"
- Color : BKF (Black Flat)

GRG270B BKN

- GRG2 Maple neck
- Basswood body
- Medium frets
- Edge III bridge
- PSND1 (H) neck pu
- PSNDS (S) mid pu
- PSND2 (H) bridge pu
- Hardware color : Black
- Scale : 648mm/25.5"
- Colors : BKN (Black Night)
LPM (Light Purple Metallic)

GRG270B LPM

- GRG2 Maple neck
- Basswood body
- Medium frets
- Edge III bridge
- PSND1 (H) neck pu
- PSNDS (S) mid pu
- PSND2 (H) bridge pu
- Hardware color : Black
- Scale : 648mm/25.5"
- Colors : BKN (Black Night)
LPM (Light Purple Metallic)

GRG170DX CA

- GRG1 Maple neck
- Basswood body
- Medium frets
- Fat 10 bridge
- PSND1 (H) neck pu
- PSNDS (S) mid pu
- PSND2 (H) bridge pu
- Hardware color : Chrome
- Scale : 648mm/25.5"
- Colors : CA (Candy Apple)
BKN (Black Night)
JB (Jewel Blue)

GRG170DX JB

- GRG1 Maple neck
- Basswood body
- Medium frets
- Fat 10 bridge
- PSND1 (H) neck pu
- PSNDS (S) mid pu
- PSND2 (H) bridge pu
- Hardware color : Chrome
- Scale : 648mm/25.5"
- Colors : CA (Candy Apple)
BKN (Black Night)
JB (Jewel Blue)

GRG170DX BKN

- GRG1 Maple neck
- Basswood body
- Medium frets
- Fat 10 bridge
- PSND1 (H) neck pu
- PSNDS (S) mid pu
- PSND2 (H) bridge pu
- Hardware color : Chrome
- Scale : 648mm/25.5"
- Colors : CA (Candy Apple)
BKN (Black Night)
JB (Jewel Blue)

GRG170DXL BKN

- Left-handed
- GRG1 Maple neck
- Basswood body
- Medium frets
- Fat 10 bridge
- PSND1 (H) neck pu
- PSNDS (S) mid pu
- PSND2 (H) bridge pu
- Hardware color : Chrome
- Scale : 648mm/25.5"
- Color : BKN (Black Night)

S Prestige

CRAFTED BY JAPAN'S FINEST LUTHIERS

The S Prestige series is "Made in Japan" by the finest Ibanez craftsmen and from top-of-the-line components. This beautifully contoured shape, combined with the ZR-2 tremolo system, produces warm resonant tones from a super thin mahogany body.



HGD & ST Pickups

The Hot Grinder pickups are specially designed for the S Prestige to output extra volume, yet sharpness is not sacrificed. The new Short Tracer pickup matches perfectly with the hot humbuckers to give versatility on the S guitars and to produce even the most delicate tones.



Ken Susi
Unearth



S5470F RVK

- 5pc Super Wizard HP Maple/Walnut neck *Prestige* w/KTS™ TITANIUM Reinforcement
- Flamed Maple top/ Mahogany body
- Jumbo frets
- ZR-2 bridge w/ZPS3
- HGD1 (H) neck pu
- ST2 (S) middle pu
- HGD2 (H) bridge pu
- Hardware color : Cosmo Black
- Scale : 648mm/25.5"
- Colors : RVK (Red Viking) BH (Black Haze)



S5470F BH

- 5pc Super Wizard HP Maple/Walnut neck *Prestige* w/KTS™ TITANIUM Reinforcement
- Flamed Maple top/ Mahogany body
- Jumbo frets
- ZR-2 bridge w/ZPS3
- HGD1 (H) neck pu
- ST2 (S) middle pu
- HGD2 (H) bridge pu
- Hardware color : Cosmo Black
- Scale : 648mm/25.5"
- Colors : RVK (Red Viking) BH (Black Haze)



S5470 TKS

- 5pc Super Wizard HP Maple/Walnut neck *Prestige* w/KTS™ TITANIUM Reinforcement
- Mahogany body
- Jumbo frets
- ZR-2 bridge w/ZPS3
- HGD1 (H) neck pu
- ST2 (S) middle pu
- HGD2 (H) bridge pu
- Hardware color : Cosmo Black
- Scale : 648mm/25.5"
- Color : TKS (Transparent Black Sunburst)



S7420 BK

- 3pc Wizard II-7 Maple neck
- Mahogany body
- Jumbo frets
- ZR-7 bridge w/ZPS2
- AH1-7 (H) neck pu
- AH2-7 (H) bridge pu
- Hardware color : Cosmo Black
- Scale : 648mm/25.5"
- Color : BK (Black)



Buz McGrath
Unearth



S570B RD

- 3pc Wizard II Maple neck
- Mahogany body
- Jumbo frets
- ZR bridge w/ZPS2
- INF1 (H) neck pu
- INF51 (S) mid pu
- INF2 (H) bridge pu
- Hardware color : Black
- Scale : 648mm/25.5"
- Colors : RD (Red) SKB (Sky Blue) WH (White)



S570B WH

- 3pc Wizard II Maple neck
- Mahogany body
- Jumbo frets
- ZR bridge w/ZPS2
- INF1 (H) neck pu
- INF51 (S) mid pu
- INF2 (H) bridge pu
- Hardware color : Black
- Scale : 648mm/25.5"
- Colors : RD (Red) SKB (Sky Blue) WH (White)



S570B SKB

- 3pc Wizard II Maple neck
- Mahogany body
- Jumbo frets
- ZR bridge w/ZPS2
- INF1 (H) neck pu
- INF51 (S) mid pu
- INF2 (H) bridge pu
- Hardware color : Black
- Scale : 648mm/25.5"
- Colors : RD (Red) SKB (Sky Blue) WH (White)



Luke Hoskin
Protest the Hero



S570 BK

- 3pc Wizard II Maple neck
- Mahogany body
- Jumbo frets
- ZR bridge w/ZPS2
- INF1 (H) neck pu
- INF51 (S) mid pu
- INF2 (H) bridge pu
- Hardware color : Cosmo Black
- Scale : 648mm/25.5"
- Color : BK (Black)



S(regular) /24 frets

For 2010 – with a two-octave fretboard, the new S models allow players even more creative freedom.



S420 WK

- 3pc Wizard II Maple neck
- Mahogany body
- Jumbo frets
- ZR bridge w/ZPS2
- INF1 (H) neck pu
- INF2 (H) bridge pu
- Hardware color : Cosmo Black
- Scale : 648mm/25.5"
- Color : WK (Weathered Black)



S770FM ATF

- 3pc Wizard II Maple neck
- Flamed Maple top/Mahogany body
- Jumbo frets
- ZR bridge w/ZPS2
- INF1 (H) neck pu
- INF51 (S) mid pu
- INF2 (H) bridge pu
- Hardware color : Cosmo Black
- Scale : 648mm/25.5"
- Color : ATF (Antique Burst Flat)



Oskar Montelius
Sabaton

The Ibanez S series first appeared in 1987. Ever since, it has changed in appearance and function to represent the cutting edge of Ibanez design. Famous for its lightweight carved mahogany body, the S can take a beating while still providing the resonance of guitars twice its size. The S series also comes equipped with the ZR-2 tremolo system, a smooth ball bearing tremolo that makes every subtle nuance of whammy bar use come alive.

Gizz Butt
The More I See
 Photo by Nigel Crane



Tobias Buck
Neera



Stefan Keller
Neera

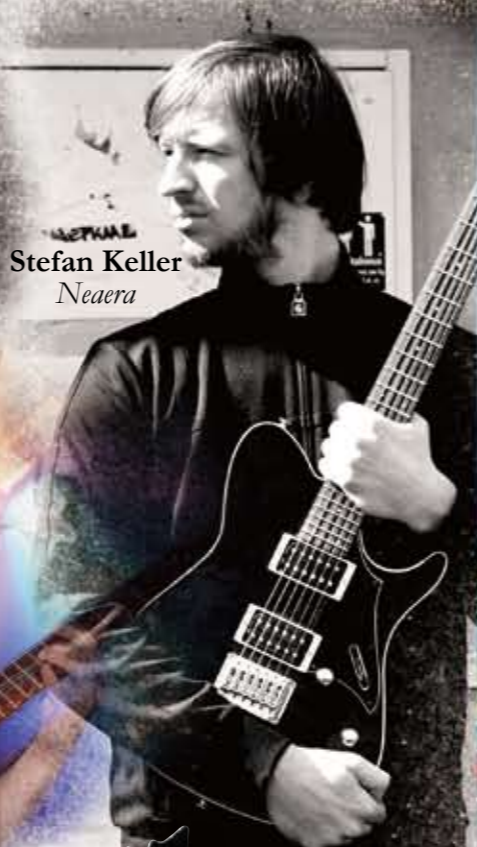

Peter Goemaere

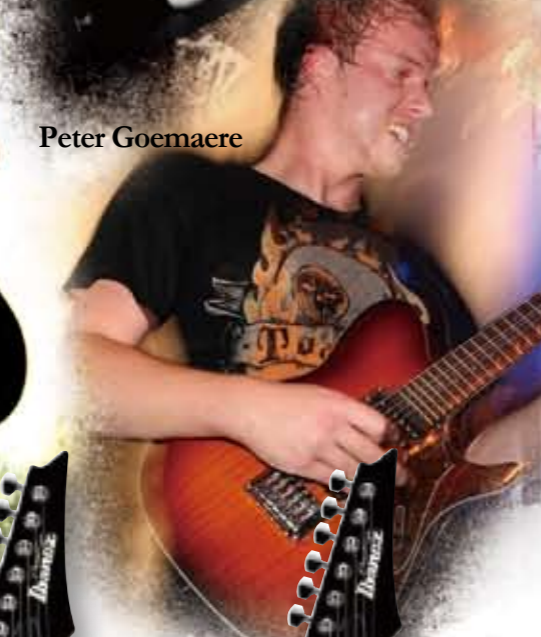

Andreas Gerhard
Aloha from Hell



SV *Prestige*

CRAFTED BY JAPAN'S FINEST LUTHIERS
 The S series has long been admired for its design, but some players prefer the simplicity of a non-locking tremolo. The SV was created to satisfy the professional player, who wants a more versatile solution. The SynchroniZR non-locking tremolo uses the same smooth ball bearing mechanisms that have made the ZR bridge so popular. The SV also comes equipped with the True-Duo pickup system for superior tonal variety from the single coil and humbucker universe.

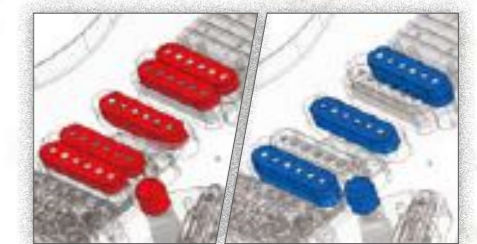

True-Duo Pickups

The unique formula of the True-Duo system, the combination of Alnico and Ferrite, stacked coils and bar magnet, has answered the conflicting demand for one guitar. In the SSS setting, it outputs glassy and clear single coil sound, not like a coil tap does, while the HSH setting packs a beefy punch, by simply pushing/pulling the volume knob.



SV/Machine Head Auto-Trim Tuner

Smart design cuts the excess string after you re-string and tune up – no extra cutting tool needed!



SV/Graphtech® Nut

The Graphtech® nut on the SV models offers ultimately low friction to keep you in tune and gives clearer sound and sustain.

FR *Prestige*

CRAFTED BY JAPAN'S FINEST LUTHIERS
 The FR first appeared in 2008. With a simple and uncompromising design, the FR is a chameleon when it comes to musical genres. The ash body brings more punch to the midrange tones, while the Tight-End bridge provides maximum string vibration and playing comfort.

FR2620 DBS

- 5pc Wizard HP Maple /Walnut neck *Prestige*
- Ash body
- Jumbo frets
- Tight-End bridge
- CCR1 (H) neck pu
- CCR2 (H) bridge pu
- Hardware color : Chrome
- Scale : 648mm/25.5"
- Colors : DBS (Dark Brown Sunburst) NT (Natural)

FR2620 NT

- 5pc Wizard HP Maple /Walnut neck *Prestige*
- Ash body
- Jumbo frets
- Tight-End bridge
- CCR1 (H) neck pu
- CCR2 (H) bridge pu
- Hardware color : Chrome
- Scale : 648mm/25.5"
- Colors : DBS (Dark Brown Sunburst) NT (Natural)

FR1620 BK

- 5pc Wizard HP Maple /Walnut neck *Prestige*
- Ash body
- Jumbo frets
- Tight-End bridge
- CCR1 (H) neck pu
- CCR2 (H) bridge pu
- Hardware color : Chrome
- Scale : 648mm/25.5"
- Color : BK (Black)

SV5470A BKD

- 5pc Wizard HP Maple /Walnut neck *Prestige*
- Ash top/Mahogany body
- Jumbo frets
- SynchroniZR bridge w/ZPS-FX
- TDB2 (H) neck pu
- ST2 (S) mid pu
- TDB3 (H) brdige pu
- Hardware color : Cosmo Black
- Scale : 648mm/25.5"
- Color : BKD (Black Blond)

SV5470F DSB

- 5pc Wizard HP Maple /Walnut neck *Prestige*
- Flamed Maple top/Mahogany body
- Jumbo frets
- SynchroniZR bridge w/ZPS-FX
- TDB2 (H) neck pu
- ST2 (S) mid pu
- TDB3 (H) brdige pu
- Hardware color : Cosmo Black
- Scale : 648mm/25.5"
- Colors : DSB (Dark Sunset Burst) NBL (Natural Blue)

SV5470F NBL

- 5pc Wizard HP Maple /Walnut neck *Prestige*
- Flamed Maple top/Mahogany body
- Jumbo frets
- SynchroniZR bridge w/ZPS-FX
- TDB2 (H) neck pu
- ST2 (S) mid pu
- TDB3 (H) brdige pu
- Hardware color : Cosmo Black
- Scale : 648mm/25.5"
- Colors : DSB (Dark Sunset Burst) NBL (Natural Blue)

CCR Pickups

The Ibanez original CCR pickups don't have the same heat of ceramic magnets, but still have the power to cut through the mix.



SA

You want versatility? The SA adapts to any genre of music for clean rhythm, crunchy blues or even hard-driving riffs and solos. It also offers a variety of looks such as metal-like solid color or traditional wooden finishes. The SA also makes use of the same True-Duo pickup system available on the SV models and the abundant resonance of the SAT-Pro tremolo.



SA260FM TLB

- 3pc SA Maple neck
- Flamed Maple top /Mahogany body
- Medium frets
- SAT Pro II bridge
- AHS1 (S) neck pu
- AHS2 (S) mid pu
- True-Duo Bucker (H) bridge pu
- Hardware color: Chrome
- Scale: 648mm/25.5"
- Colors: AMB (Amber Burst)

TLB (Transparent Lavender Burst)



SA260FML TLB

- Left-handed
- 3pc SA Maple neck
- Flamed Maple top /Mahogany body
- Medium frets
- SAT Pro II bridge
- AHS1 (S) neck pu
- AHS2 (S) mid pu
- True-Duo Bucker (H) bridge pu
- Hardware color: Chrome
- Scale: 648mm/25.5"
- Color: TLB (Transparent Lavender Burst)



SAS36FM TRS

- 3pc SAS Maple set-in neck
- Flamed Maple top/Mahogany body
- Medium frets
- SAT Pro II bridge
- AHS1 (S) neck pu
- AHS2 (S) mid pu
- True-Duo Bucker (H) bridge pu
- Hardware color: Chrome
- Scale: 648mm/25.5"
- Color: TRS (Transparent Red Sunburst)



SAS36QM CBS

- 3pc SAS Maple set-in neck
- Quilted Maple top/Mahogany body
- Medium frets
- SAT Pro II bridge
- AHS1 (S) neck pu
- AHS2 (S) mid pu
- True-Duo Bucker (H) bridge
- Hardware color: Chrome
- Scale: 648mm/25.5"
- Color: CBS (Cornflower Blue Sunburst)

Sat Pro II Tremolo

The Sat Pro II eliminates unnecessary resonance around the saddles by firmly securing them to the bridge plate. This keeps the saddles very stable even during frequent tremolo use.



SA260FM AMB

- 3pc SA Maple neck
- Flamed Maple top/Mahogany body
- Medium frets
- SAT Pro II bridge
- AHS1 (S) neck pu
- AHS2 (S) mid pu
- True-Duo Bucker (H) bridge pu
- Hardware color: Chrome
- Scale: 648mm/25.5"
- Colors: AMB (Amber Burst)

TLB (Transparent Lavender Burst)



SAS32EX BK

- 3pc SAS Maple set-in neck
- Mahogany body
- Medium frets
- SAT Pro II bridge
- True-Duo Bucker (H) neck pu
- True-Duo Bucker (H) bridge pu
- Hardware color: Cosmo Black
- Scale: 648mm/25.5"
- Color: BK (Black)



SAS32EXFM AV

- 3pc SAS Maple set-in neck
- Flamed Maple top /Mahogany body
- Medium frets
- SAT Pro II bridge
- True-Duo Bucker (H) neck pu
- True-Duo Bucker (H) bridge pu
- Hardware color: Cosmo Black
- Scale: 648mm/25.5"
- Color: AV (Antique Violin)



SA120EX BK

- 3pc SA Maple neck
- Mahogany body
- Medium frets
- SAT Pro II bridge
- AHS (H) neck pu
- AH6 (H) bridge pu
- Hardware color: Cosmo Black
- Scale: 648mm/25.5"
- Color: BK (Black)

Rob Daniels
Jimmy Wayne Band

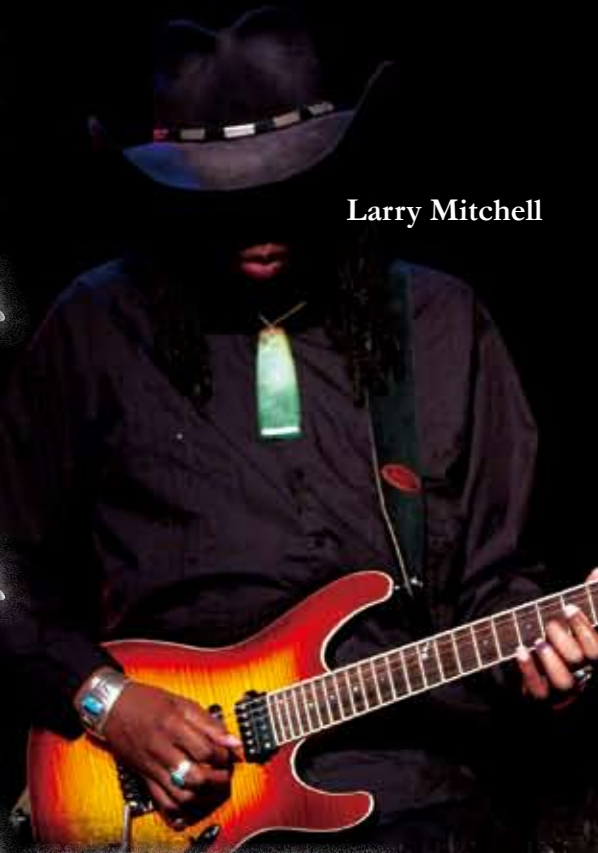

Larry Mitchell



Set-in Neck Construction

SAS set-in neck features strong 3pc construction and special neck finish for extraordinary comfort and playability.



GSA60 WH

- Maple neck
- Agathis body
- Medium frets
- SAT10 bridge
- PSNDS (S) neck pu
- PSNDS (S) mid pu
- PSND2 (H) bridge pu
- Hardware color: Chrome
- Scale: 648mm/25.5"
- Colors: BKN (Black Night) BS (Brown Sunburst) WH (White)



GSA60 BS

- Maple neck
- Agathis body
- Medium frets
- SAT10 bridge
- PSNDS (S) neck pu
- PSNDS (S) mid pu
- PSND2 (H) bridge pu
- Hardware color: Chrome
- Scale: 648mm/25.5"
- Colors: BKN (Black Night) BS (Brown Sunburst) WH (White)



GSA60 BKN

- Maple neck
- Agathis body
- Medium frets
- SAT10 bridge
- PSNDS (S) neck pu
- PSNDS (S) mid pu
- PSND2 (H) bridge pu
- Hardware color: Chrome
- Scale: 648mm/25.5"
- Colors: BKN (Black Night) BS (Brown Sunburst) WH (White)



Nightmare Industries
Deathstars

Cat Casino
Deathstars

Isaac Delahaye
Epica

Rikard Sundén
Sabaton

Christoph Siemons
Krypteria

Photo by Tim Tronckoe

Logan
Deadly Motor Vehicles

DN DARKSTONE

The DN is the new standard in heavy metal rock guitar. As its "Darkstone" series name suggests, strong construction and smart body style combine for a powerful, clean sound. The Tight-Tune Bridge is sturdy and resonant, and the tailpiece comes equipped with the Ball-End Stopper for more lock-in on strings – both are features originally designed by Ibanez.



HS1 Pickups

The newly developed humbucker-sized single coil pickups produce loud and crunchy tones that cut through for hard rock and punk styles.



DN600 SHM

- DN Sapele set-in neck
- Sapele body
- Medium frets
- Tight-Tune bridge
- Tight-Tune tailpiece
- HS1-N (S) neck pu
- HS1-B (S) bridge pu
- Hardware color : Chrome
- Scale : 628mm/24.75"
- Color : SHM (Shattered Mirror)



DN520K DTV

- DN Sapele set-in neck
- Sapele body
- Medium frets
- Tight-Tune bridge
- Tight-Tune tailpiece
- PP1-N (H) neck pu
- PP1-B (H) bridge pu
- Hardware color : Cosmo Black
- Scale : 628mm/24.75"
- Color : DTV (Dark Night Violet)



DN500 WH

- DN Sapele set-in neck
- Sapele body
- Medium frets
- Tight-Tune bridge
- Tight-Tune tailpiece
- PP1-N (H) neck pu
- PP1-B (H) bridge pu
- Hardware color : Chrome
- Scale : 628mm/24.75"
- Colors : BK (Black) WH (White)

DN500 BK

- DN Sapele set-in neck
- Sapele body
- Medium frets
- Tight-Tune bridge
- Tight-Tune tailpiece
- PP1-N (H) neck pu
- PP1-B (H) bridge pu
- Hardware color : Chrome
- Scale : 628mm/24.75"
- Colors : BK (Black) WH (White)



PP1 Pickups

The tube pole-piece construction of the new pickups designed for the Ibanez Darkstone offers quick response, sparkling clarity and added harmonics for a humbucker sound.



Escutcheon

The original pickup mounting ring, specially designed for the Darkstone, keeps the pickup parallel to the strings at all times. Unlike the usual mounting rings, this one enables the pickups to catch equal vibrations from each string and avoid tone loss.



Tight-Tune Bridge/Tailpiece

Solid as a rock, the Tight-Tune bridge and tailpiece were designed to lock down securely and prevent any kind of wobble or movement. Each saddle is locked into the base plate, and the bridge is anchored by stud bolts into the body of the guitar. Furthermore, the studs are also locked onto the base plate so that the maximum vibration from the string is transferred to the body.

Set-In Neck Construction

Set-In Neck construction on the DN-series provides massive sustain and playing comfort.

ART

Simple and effective, the ART is a classic single-cutaway guitar that was built for modern metal. The mahogany body is capable of producing the warm tones of yesterday, while the active low-impedance pickups can handle massive volume levels with very little noise.



ART320 TGB

- ART Mahogany set-in neck
- Flamed Maple top/Mahogany body
- Medium frets
- Gibraltar III bridge
- Quik Change III tailpiece
- LZ1-N (H) neck pu
- LZ1-B (H) bridge pu
- Hardware color : Cosmo Black
- Scale : 628mm/24.75"
- Color : TGB (Transparent Gray Burst)



ART600 BB

- 3pc ART Sapele/Maple set-in neck
- Quilted Maple top/Sapele body
- Medium frets
- Tight-Tune bridge
- Tight-Tune tailpiece
- LZ1-N (H) neck pu
- LZ1-B (H) bridge pu
- Hardware color : Cosmo Black
- Scale : 628mm/24.75"
- Color : BB (Blackberry)



ART/Auto Trim Tuner

Smart design cuts the excess string after you re-string and tune up – no extra cutting tool needed!



Tight-Tune Bridge/Tailpiece



Barry Stock
Three Days Grace



Sean Kipe
Course of Nature



ART120 BK

- ART Mahogany set-in neck
- Maple top/Mahogany body
- Medium frets
- Gibraltar III bridge
- Quik Change III tailpiece
- LZ1-N (H) neck pu
- LZ1-B (H) bridge pu
- Hardware color : Chrome
- Scale : 628mm/24.75"
- Colors : BK (Black)
- WH (White)
- TRF (Transparent Red Flat)



ART120 TRF

- ART Mahogany set-in neck
- Maple top/Mahogany body
- Medium frets
- Gibraltar III bridge
- Quik Change III tailpiece
- LZ1-N (H) neck pu
- LZ1-B (H) bridge pu
- Hardware color : Chrome
- Scale : 628mm/24.75"
- Colors : BK (Black)
- WH (White)
- TRF (Transparent Red Flat)



ART120 WH

- ART Mahogany set-in neck
- Maple top/Mahogany body
- Medium frets
- Gibraltar III bridge
- Quik Change III tailpiece
- LZ1-N (H) neck pu
- LZ1-B (H) bridge pu
- Hardware color : Chrome
- Scale : 628mm/24.75"
- Colors : BK (Black)
- WH (White)
- TRF (Transparent Red Flat)

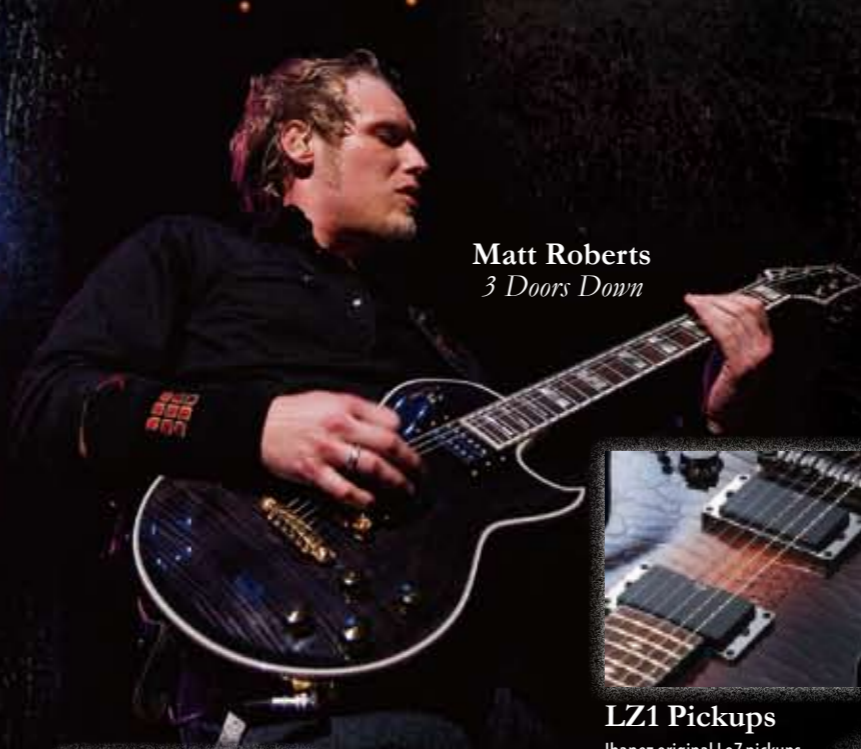

Matt Roberts
3 Doors Down



LZ1 Pickups

Ibanez original LoZ pickups have made the active pickup sounds accessible for anyone from starters to professionals. Operated by AA batteries, which are more widely available than traditional 9V batteries.



Caiman Finish

The ART300 features the Caiman finish, a unique texture created by the scalloped top. This unique top combined with dark stained finishes has the look of reptilian skin.



Gibraltar III Bridge/Quik Change III Tailpiece

With the addition of the Quik Change III tailpiece, string changes are a snap on the Gibraltar III bridge. Its simple rigid design is perfect for harder playing styles.



ART300 BNC

- ART Mahogany set-in neck
- Scalloped-Texture Maple top/Mahogany body
- Medium frets
- Gibraltar III bridge
- Quik Change III tailpiece
- LZ1-N (H) neck pu
- LZ1-B (H) bridge pu
- Hardware color : Cosmo Black
- Scale : 628mm/24.75"
- Colors : BNC (Brown Caiman)
- VTC (Violet Caiman)

ART300 VTC

- ART Mahogany set-in neck
- Scalloped-Texture Maple top/Mahogany body
- Medium frets
- Gibraltar III bridge
- Quik Change III tailpiece
- LZ1-N (H) neck pu
- LZ1-B (H) bridge pu
- Hardware color : Cosmo Black
- Scale : 628mm/24.75"
- Colors : BNC (Brown Caiman)
- VTC (Violet Caiman)



ART80 CA

- ART Mahogany set-in neck
- Mahogany body
- Medium frets
- Gibraltar III bridge
- Quik Change III tailpiece
- ACH1 (H) neck pu
- ACH2 (H) bridge pu
- Hardware color : Cosmo Black
- Scale : 628mm/24.75"
- Colors : BK (Black)
- CA (Candy Apple)

ART80 BK

- ART Mahogany set-in neck
- Mahogany body
- Medium frets
- Gibraltar III bridge
- Quik Change III tailpiece
- ACH1 (H) neck pu
- ACH2 (H) bridge pu
- Hardware color : Cosmo Black
- Scale : 628mm/24.75"
- Colors : BK (Black)
- CA (Candy Apple)

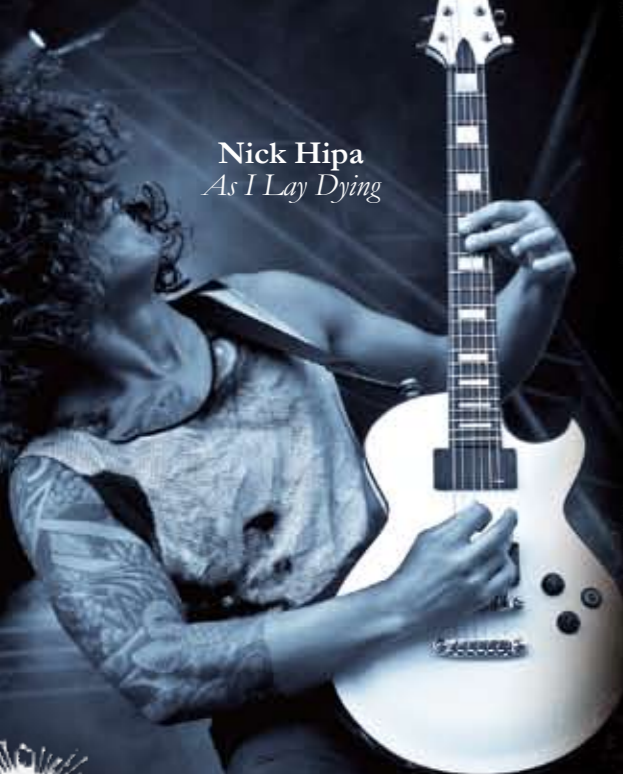

Nick Hipa
As I Lay Dying

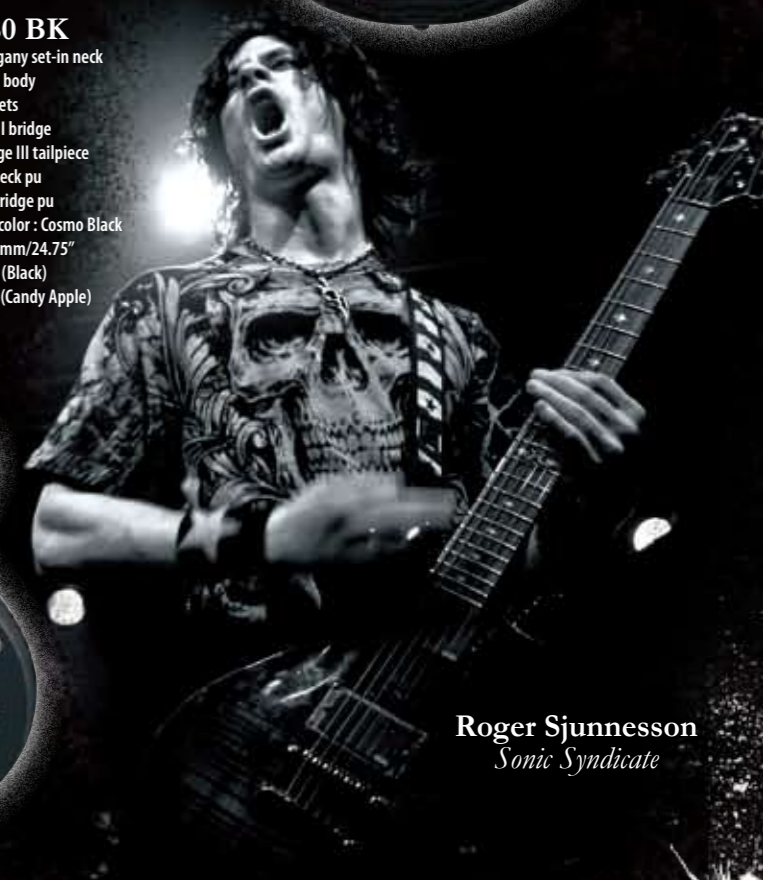

Roger Sjunnesson
Sonic Syndicate

Dino Cazares
Fear Factory, Divine Heresy

X SERIES

With the advent of the X series, Ibanez reintroduced non-traditional guitar shapes back into the mix. These off-the-wall shapes stand out in a crowd, but they are also excellent examples of form meeting function. The XPT was developed for the extreme shred player with its fast neck and tremolo system. The ICT is great for hard rock, where thick tones are literally beaten out of the guitar. The DTT is a high gain animal, cutting through the most dense forests of fuzz and distortion.

XPT700 RCM

- 5pc Wizard II Maple/Walnut neck-thru w/KTS™ TITANIUM Reinforcement
- Mahogany wing body
- Jumbo frets
- Edge III bridge
- DiMarzio® D Activator™ (H) neck pu
- DiMarzio® D Activator™ (H) bridge pu
- Hardware color: Cosmo Black
- Scale: 648mm/25.5"
- Color: RCM (Red Chameleon)



XPT700XH GSF

- 5pc Wizard II Maple/Walnut neck-thru w/KTS™ TITANIUM Reinforcement
- Mahogany wing body
- Jumbo frets
- Edge III bridge
- DiMarzio® Air Norton™ (H) neck pu
- DiMarzio® D Activator™ (H) bridge pu
- Hardware color: Black
- Scale: 648mm/25.5"
- Color: GSF (Green Shadow Flat)

27 fret/DiMarzio® Air Norton S™ Neck Pickup

The XPT700XH joins its shred-friendly features, such as 27 frets for full access to the upper frets, with the same exact placement of the neck pickup used on the other Xiphos guitars using the Air Norton S™.

XP300FX BK

- 3pc Wizard II Maple neck
- Mahogany body
- Jumbo frets
- Fixed bridge
- INF3 (H) neck pu
- INF4 (H) bridge pu
- Hardware color: Cosmo Black
- Scale: 648mm/25.5"
- Color: BK (Black)

Terji Skibenæs
Tyr

Muhammed Suiçmez
Necrophagist

Oli Herbert
All That Remains



DiMarzio® D Activator-X™ Pickups

DiMarzio® D Activator-X™ pickups combine extreme power and clarity through the use of specially tuned coils.



Neck-Thru Construction

Neck-thru construction on the XPT700/XPT700XH/DTT700/ICT700 provides massive sustain and playing comfort.

DTT700 MGS

- 5pc Wizard II Maple/Walnut neck-thru w/KTS™ TITANIUM Reinforcement
- Mahogany wing body
- Jumbo frets
- Gibraltar Custom bridge
- DiMarzio® D Activator-X™ (H) neck pu
- DiMarzio® D Activator-X™ (H) bridge pu
- Hardware color: Chrome
- Scale: 648mm/25.5"
- Color: MGS (Metallic Gray Sunburst)

Eyal Levi
Dååth

ICT700 BK

- 5pc Wizard II Maple/Walnut neck-thru w/KTS™ TITANIUM Reinforcement
- Mahogany wing body
- Jumbo frets
- Gibraltar Custom bridge
- DiMarzio® D Activator™ (H) neck pu
- DiMarzio® D Activator™ (H) bridge pu
- Hardware color: Black
- Scale: 648mm/25.5"
- Color: BK (Black)



DiMarzio® D Activator™ pickups

DiMarzio® D Activator™ mounted on ICT700

Marcus Sunesson
Engel

Niclas Engelin
Engel

AR ARTIST

The AR is a classic among Ibanez guitars. It was one of the first original designs produced by Ibanez and continues to be a sought after guitar. The AR300 continues that legacy with pride.

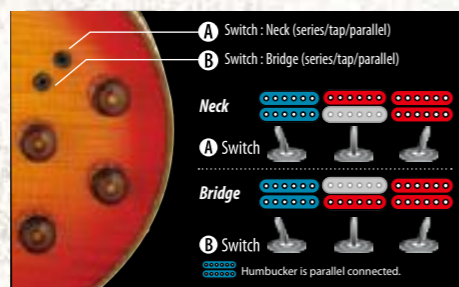

AR250 BK

- 3pc AR Maple set-in neck
- Maple top/ Mahogany body
- Medium frets
- ART-1 bridge
- Quik Change III tailpiece
- ACH1 (H) neck pu
- ACH2 (H) bridge pu
- Hardware color : Gold
- Scale : 628mm/24.75"
- Color : BK (Black)

Tri-Sound Sw

The AR300RE's original Tri-Sound switching system offers the choice of standard humbucking, single coil, or parallel humbucking sounds through the mini switches. Combined with the regular pickup selector, 15 distinct tone settings are available at your fingertips.

AR200FM HS

- 3pc AR Maple set-in neck
- Flamed Maple top/ Mahogany body
- Medium frets
- ART-1 bridge
- Quik Change III tailpiece
- ACH1-S (H) neck pu
- ACH2-S (H) bridge up
- Hardware color : Chrome
- Scale : 628mm/24.75"
- Color : HS (Honey Sunburst)

AR300RE CS

- 3pc AR Maple set-in neck *Prestige*
- Flamed Maple top/Mahogany body
- Medium frets
- Gibraltar bridge w/Sustain Block
- Quik Change tailpiece
- Super 58 (H) neck pu
- Super 58 (H) bridge pu
- Hardware color : Gold
- Scale : 628mm/24.75"
- Color : CS (Cherry Sunburst)

GAX

If simplicity is what you're after, the GAX may be your rock weapon of choice. This double-cutaway guitar does away with frills, but it keeps the stuff that matters.

GAX30 TR

- GAX1 Maple neck
- Agathis body
- Medium frets
- Fixed bridge
- PSND1 (H) neck pu
- PSND2 (H) bridge pu
- Hardware color : Chrome
- Scale : 628mm/24.75"
- Colors : BKN (Black Night) TR (Transparent Red)

GAX30 BKN

- GAX1 Maple neck
- Agathis body
- Medium frets
- Fixed bridge
- PSND1 (H) neck pu
- PSND2 (H) bridge pu
- Hardware color : Chrome
- Scale : 628mm/24.75"
- Colors : BKN (Black Night) TR (Transparent Red)



Gibraltar w/ Sustain Block

This is a faithful reproduction of the Original Gibraltar bridge.

JTK JET KING

Some people never forget that first prized guitar that they found at the local pawnshop, and with the JTK they'll never have to. The Jet King takes all the retro styling of a vintage guitar and couples it with solid, modern hardware. Ibanez also developed original low-noise pickups for the Jet King that reproduce the old-school look and sound of soap bar pickups.

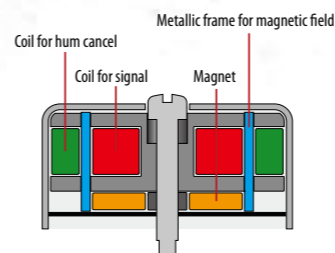

HFS Pickups

The HFS PU looks like a vintage single coil at first glance, but looks can be deceiving. Underneath, the HFS makes use of a separate coil to cancel any hum or noise generated by the single coil.



Rob Patterson
Dr. Z

Andy Jackson
Hot Rod Circuit



VBX60 Vibrato

Ibanez VBX60 Vintage Vibrato for solid body guitars.

JTK40 RD

- 3pc JTK Maple neck
- Mahogany body
- Medium frets
- Full Tune III bridge w/ ROLLER SADDLE
- VBX60 vibrato
- ACH3 (H) neck pu
- ACH4 (H) bridge pu
- Hardware color : Chrome
- Scale : 648mm/25.5"
- Color : RD (Red)

JTK30H BK

- 3pc JTK Maple neck
- Mahogany body
- Medium frets
- Full Tune III bridge
- HFS1 (S) neck pu
- HFS2 (S) bridge pu
- Hardware color : Chrome
- Scale : 648mm/25.5"
- Color : BK (Black)

JTK30 TQ

- 3pc JTK Maple neck
- Mahogany body
- Medium frets
- Full Tune III bridge
- HFS1 (S) neck pu
- HFS2 (S) bridge pu
- Hardware color : Chrome
- Scale : 648mm/25.5"
- Colors : TQ (Turquoise) BSV (Brilliant Silver)

JTK30 BSV

- 3pc JTK Maple neck
- Mahogany body
- Medium frets
- Full Tune III bridge
- HFS1 (S) neck pu
- HFS2 (S) bridge pu
- Hardware color : Chrome
- Scale : 648mm/25.5"
- Colors : TQ (Turquoise) BSV (Brilliant Silver)





JS2400/24 Frets & DiMarzio® Mo'Joe™

The first 24-fret fingerboard JS model is Joe Satriani's newest adventure in guitars and includes his favorite DiMarzio® pickups.

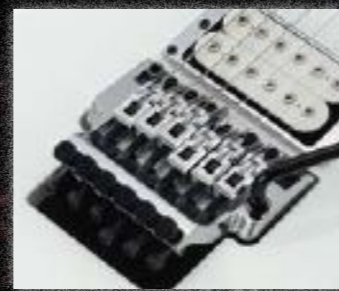

JS/Edge Tremolo

The legendary, original Edge tremolo bridge is back, always Joe's favorite in feel and tone.

JOE SATRIANI SIGNATURE MODELS



JS2400 WH

- 1pc JS Maple neck *Prestige*
- Basswood body
- W/6105 frets
- Edge bridge
- DiMarzio® Pro Track™ (H) neck pu
- DiMarzio® Mo'Joe™ (H) bridge pu
- Hardware color : Chrome
- Scale : 648mm/25.5"
- Color : WH (White)



JS1600 PSV

- 1pc JS Maple neck *Prestige*
- Mahogany body
- W/6105 frets
- Fixed bridge
- DiMarzio® Paf Pro® (H) neck pu
- DiMarzio® Fred™ (H) bridge pu
- Hardware color : Chrome
- Scale : 648mm/25.5"
- Color : PSV (Premium Silver)



JS1200 CA

- 1pc JS Maple neck *Prestige*
- Basswood body
- W/6105 frets
- Edge bridge
- DiMarzio® Paf Joe™ (H) neck pu
- DiMarzio® Fred™ (H) bridge pu
- Hardware color : Chrome
- Scale : 648mm/25.5"
- Color : CA (Candy Apple)



JS1000 BP

- 1pc JS Maple neck *Prestige*
- Basswood body
- W/6105 frets
- Edge bridge
- DiMarzio® Paf Pro® (H) neck pu
- DiMarzio® Fred™ (H) bridge pu
- Hardware color : Cosmo Black
- Scale : 648mm/25.5"
- Color : BP (Black Pearl)



JS100 BK

- 1pc JS Maple neck
- Basswood body
- Large frets
- Edge III bridge
- AH1 (H) neck pu
- AH2 (H) bridge pu
- Hardware color : Chrome
- Scale : 648mm/25.5"
- Colors : BK (Black)
TR (Transparent Red)



JS100 TR

- 1pc JS Maple neck
- Basswood body
- Large frets
- Edge III bridge
- AH1 (H) neck pu
- AH2 (H) bridge pu
- Hardware color : Chrome
- Scale : 648mm/25.5"
- Colors : BK (Black)
TR (Transparent Red)

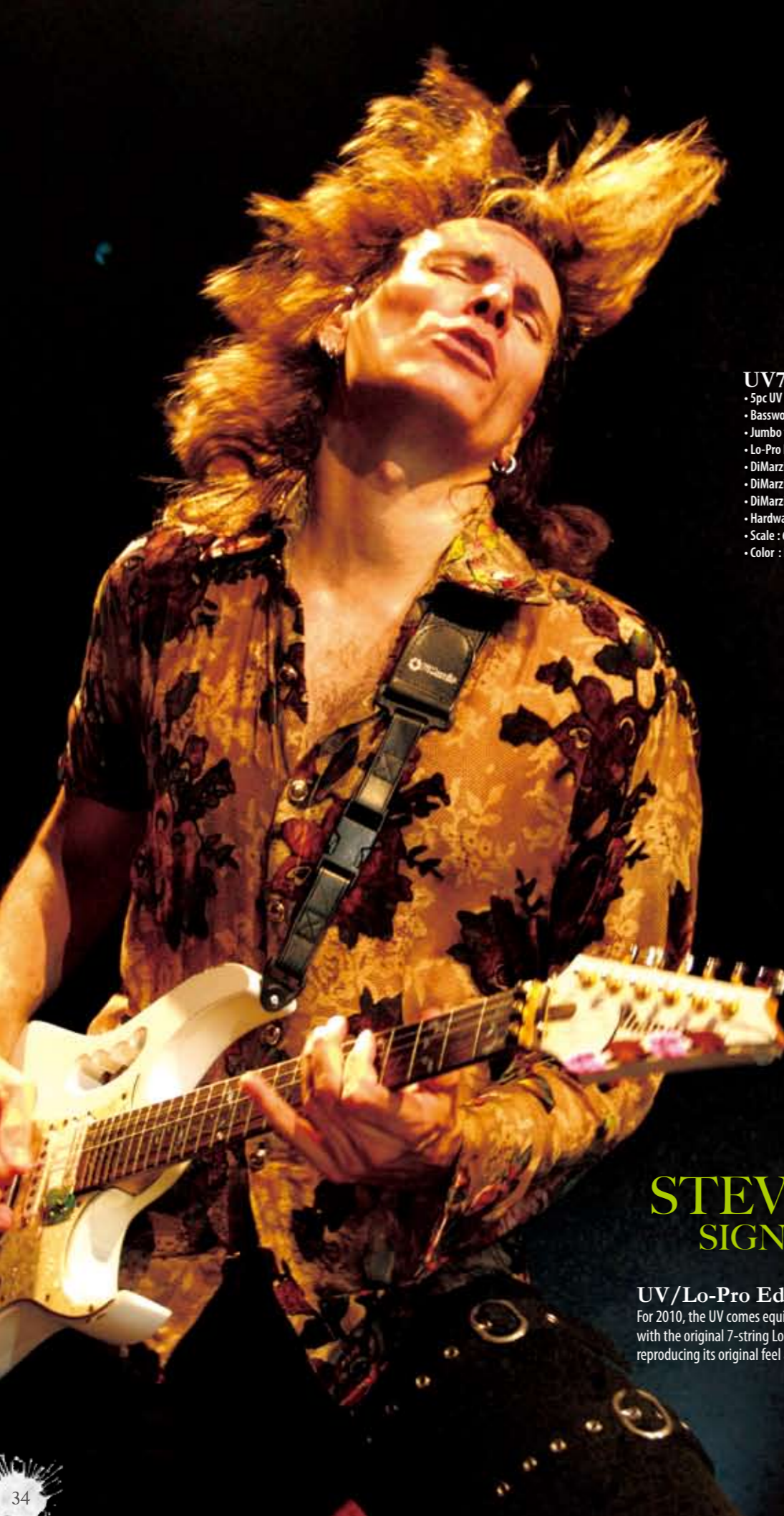

UV777P BK

- 5pc UV Maple/Wenge neck *Prestige*
- Basswood body
- Jumbo frets
- Lo-Pro Edge 7 bridge
- DiMarzio® Blaze™ (H) neck pu
- DiMarzio® Blaze™ (S) mid pu
- DiMarzio® Blaze™ (H) bridge pu
- Hardware color : Chrome
- Scale : 648mm/25.5"
- Color : BK (Black)



STEVE VAI SIGNATURE MODELS

UV/Lo-Pro Edge

For 2010, the UV comes equipped with the original 7-string Lo-Pro Edge, reproducing its original feel and look.



JEM7V WH

- 5pc JEM Maple/Walnut neck *Prestige*
- Alder body
- W/6105 frets
- Edge bridge
- DiMarzio® Evolution® (H) neck pu
- DiMarzio® Evolution® (S) mid pu
- DiMarzio® Evolution® (H) bridge pu
- Hardware color : Gold
- Scale : 648mm/25.5"
- Color : WH (White)



JEM77V BK

- 5pc JEM Maple/Walnut neck *Prestige*
- Basswood body
- W/6105 frets
- Edge bridge
- DiMarzio® Breed™ (H) neck pu
- DiMarzio® Breed™ (S) mid pu
- DiMarzio® Breed™ (H) bridge pu
- Hardware color : Chrome
- Scale : 648mm/25.5"
- Color : BK (Black)



JEM505 BK

- 5pc JEM Maple/Walnut neck *Prestige*
- Basswood body
- W/6105 frets
- Edge bridge
- V7 (H) neck pu
- S1 (S) mid pu
- V8 (H) bridge pu
- Hardware color : Cosmo Black
- Scale : 648mm/25.5"
- Colors : BK (Black)
WH (White)



JEM505 WH

- 5pc JEM Maple/Walnut neck *Prestige*
- Basswood body
- W/6105 frets
- Edge bridge
- V7 (H) neck pu
- S1 (S) mid pu
- V8 (H) bridge pu
- Hardware color : Cosmo Black
- Scale : 648mm/25.5"
- Colors : BK (Black)
WH (White)



JEM555 WH

- 3pc Wizard II Maple neck
- Basswood body
- Jumbo frets
- Edge III bridge
- DiMarzio® Evolution® (H) neck pu
- DiMarzio® Evolution® (S) mid pu
- DiMarzio® Evolution® (H) bridge pu
- Hardware color : Cosmo Black
- Scale : 648mm/25.5"
- Color : WH (White)

DRAGONFORCE
Herman Li
 SIGNATURE MODELS



EGEN8 PLB

- 3pc Wizard II Maple neck
- Flamed Maple top/Mahogany body
- Jumbo frets
- Edge III bridge (Herman Li special)
- V7 (H) neck pu
- S1 (S) mid pu
- V8 (H) bridge pu
- Hardware color : Gold
- Scale : 648mm/25.5"
- Color : PLB (Platinum Blonde)

EGEN18 TVF

- 3pc EGEN Maple/Walnut neck *Prestige*
- Flamed Maple top/Mahogany body
- Jumbo frets
- Edge-Zero bridge w/ZPS3
- DiMarzio® HLM (H) neck pu
- DiMarzio® HLM (S) mid pu
- DiMarzio® HLM (H) bridge pu
- Hardware color : Gold
- Scale : 648mm/25.5"
- Color : TVF (Transparent Violet Flat)

EGEN18/Scalloped Fingerboard

The scalloped fingerboard on the upper frets is Herman Li's own touch, for easier high note bending and tapping.

Deeper Cut Horn

Modeled using Herman's hand. EGEN's unique scoop cutaway at the back of the body, allows even easier access to high frets from all angles.

Low-Profile Middle Pickup Setting

The Custom DiMarzio® pickup set is designed for a low-profile setting in the middle pickup position, to not get in the way of heavy rhythm down strokes to shredding alternate picking.

DRAGONFORCE
Sam Totman
 SIGNATURE MODEL



STM1 WH

- 3pc Wizard II Maple/Walnut neck-thru w/KTS™ TITANIUM Reinforcement
- Mahogany wing body
- Jumbo frets
- Edge III bridge
- DiMarzio® Evolution® (H) neck pu
- DiMarzio® Evolution® (H) bridge pu
- Hardware color : Chrome
- Scale : 648mm/25.5"
- Color : WH (White)

SLIPKNOT
Mick Thomson
 SIGNATURE MODELS

Photo by Kevin Estrada



MTM1 BR

- 3pc Wizard II Maple/Walnut neck-thru w/KTS™ TITANIUM Reinforcement
- Mahogany wing body
- Jumbo frets
- FX Lo-Pro Edge bridge
- Seymour Duncan® Blackouts AHB-3 (H) neck pu
- Seymour Duncan® Blackouts AHB-3 (H) bridge pu
- Hardware color : Black
- Scale : 648mm/25.5"
- Factory tuning: 1C#, 2G#, 3E, 4B, 5F#, 6B
- String gauge: .011/.014/.018/.028/.038/.049
- Color : BR (Blood Red)

MTM2 BK

- 3pc Wizard II Maple/Walnut neck
- Mahogany body
- Jumbo frets
- FX Edge III bridge
- Duncan® HB-105MT (H) neck pu
- Duncan® HB-105MT (H) bridge pu
- Hardware color : Black
- Scale : 648mm/25.5"
- Factory tuning: 1C#, 2G#, 3E, 4B, 5F#, 6B
- String gauge: .011/.014/.018/.028/.038/.049
- Colors : BK (Black) WH (White)

MTM2 WH

- 3pc Wizard II Maple/Walnut neck
- Mahogany body
- Jumbo frets
- FX Edge III bridge
- Duncan® HB-105MT (H) neck pu
- Duncan® HB-105MT (H) bridge pu
- Hardware color : Black
- Scale : 648mm/25.5"
- Factory tuning: 1C#, 2G#, 3E, 4B, 5F#, 6B
- String gauge: .011/.014/.018/.028/.038/.049
- Colors : BK (Black) WH (White)

MTM2/ Painted Neck

The MTM2 comes with a matching color neck back.

MBM1 BK

- 3pc Wizard Maple/Walnut neck *Prestige*
- Mahogany body
- Jumbo frets
- Gibraltar Plus bridge
- EMG® 60 (H) neck pu
- EMG® 81 (H) bridge pu
- Hardware color : Cosmo Black
- Scale : 648mm/25.5"
- Factory tuning : 1D, 2A, 3F, 4C, 5G, 6D
- String gauge: .011/.014/.018/.030/.042/.052
- Color : BK (Black)

MBM2 SV

- 3pc Wizard II Maple neck
- Mahogany body
- Jumbo frets
- Gibraltar Standard bridge
- EMG® 60 (H) neck pu
- EMG® 81 (H) bridge pu
- Hardware color : Black
- Scale : 648mm/25.5"
- Factory tuning: 1D, 2A, 3F, 4C, 5G, 6D
- String gauge: .011/.014/.018/.030/.042/.052
- Color : SV (Silver)

SHADOWS FALL
Matt Bachand
 SIGNATURE MODELS



Andy Timmons SIGNATURE MODEL



AT100CL SB

- 1pc AT Maple neck *Prestige*
- Alder body
- Jumbo frets
- Wilkinson-Gotoh VSVG bridge
- DiMarzio® AT1™ (H) neck pu
- DiMarzio® AT1™ (H) mid pu
- DiMarzio® AT1 Custom (H) bridge pu
- Hardware color : Chrome
- Scale : 648mm/25.5"
- Color : SB (Sunburst)

AT100CL /Custom AT Pickup

The AT1-bridge pickup was specially designed and wound by DiMarzio® for Andy Timmons.



Tilt Neck Joint

The traditional neck joint has a metal plate with 4 screws, yet the tilt joint still offers easy upper fret access. Paul likes this original neck joint for its tonal characteristics.



PGM401 TFB

- 5pc PGM Maple /Walnut neck *Prestige*
- Ash body
- Medium frets
- Fixed bridge
- DiMarzio® Air Classic™ (H) neck pu
- DiMarzio® Air Classic™ (H) bridge pu
- Hardware color : Cosmo Black
- Scale : 648mm/25.5"
- Color : TFB (Tri Fade Burst)

MR.BIG Paul Gilbert SIGNATURE MODEL

THE OFFSPRING Noodles SIGNATURE MODEL



NDM2 BK

- 3pc NDM Maple neck
- Basswood body
- Large frets
- Fixed bridge
- INF1 (H) neck pu
- INF1 (S) mid pu
- INF2 (H) bridge pu
- Hardware color : Chrome
- Scale : 648mm/25.5"
- Color : BK (Black)

THE MARS VOLTA Omar Rodriguez-Lopez SIGNATURE MODELS



ORM1 WH

- 3pc ORM Mahogany neck
- Mahogany body
- Medium frets
- Gibraltar III bridge
- ACH-BL (H) bridge pu
- Hardware color : Chrome
- Scale : 610mm/24.0"
- Color : WH (White)



ORM1L WH

- Left-handed
- 3pc ORM Mahogany neck
- Mahogany body
- Medium frets
- Gibraltar III bridge
- ACH-BL (H) bridge pu
- Hardware color : Chrome
- Scale : 610mm/24.0"
- Color : WH (White)



APEX1 BBK

- 5pc APEX Maple/Wenge neck *Prestige*
- Mahogany body
- Jumbo frets
- Lo-Pro Edge 7 bridge w/U-bar
- DiMarzio® Paf 7™ (H) neck pu
- DiMarzio® Paf 7™ (H) bridge pu
- Hardware color : Powdered Cosmo Black
- Scale : 648mm/25.5"
- Factory tuning : 1D, 2A, 3F, 4C, 5G, 6D, 7A
- String gauge : .010/.013/.017/.026/.036/.046/.054
- Color : BBK (Biker's Black)

APEX2 GSF

- 5pc APEX2 Maple/Walnut neck
- Mahogany body
- Jumbo frets
- Tone Pros® 7 bridge
- DiMarzio® Paf 7™ (H) neck pu
- DiMarzio® Paf 7™ (H) bridge pu
- Hardware color : Powdered Cosmo Black
- Scale : 648mm/25.5"
- Factory tuning : 1D, 2A, 3F, 4C, 5G, 6D, 7A
- String gauge : .010/.013/.017/.026/.036/.046/.054
- Color : GSF (Green Shadow Flat)

KORN Munky SIGNATURE MODELS





George Benson SIGNATURE MODELS



- PM120 BK**
- PM Mahogany set-in neck *Prestige*
 - Maple top/back/sides
 - Medium frets
 - Gotoh®103B bridge
 - PM tailpiece
 - Silent 58 (H) neck pu
 - Silent 58 (H) bridge pu
 - Hardware color : Gold
 - Scale : 628mm/24.75"
 - Depth : 50mm at tail
 - Colors : NT (Natural)
BK (Black)



- PM120 NT**
- PM Mahogany set-in neck *Prestige*
 - Maple top/back/sides
 - Medium frets
 - Gotoh®103B bridge
 - PM tailpiece
 - Silent 58 (H) neck pu
 - Silent 58 (H) bridge pu
 - Hardware color : Gold
 - Scale : 628mm/24.75"
 - Depth : 50mm at tail
 - Colors : NT (Natural)
BK (Black)



- PM100 BK**
- PM Mahogany set-in neck *Prestige*
 - Maple top/back/sides
 - Medium frets
 - Gotoh®103B bridge
 - PM tailpiece
 - Super 58 (H) neck pu
 - Hardware color : Gold
 - Scale : 628mm/24.75"
 - Depth : 80mm at tail
 - Color : BK (Black)



- PM35 NT**
- 5pc PM Maple /Walnut set-in neck
 - Maple top/back/sides
 - Medium frets
 - ART-1 bridge
 - KT30 tailpiece
 - Super 58 Custom (H) neck pu
 - Hardware color : Gold
 - Scale : 628mm/24.75"
 - Depth : 70mm at tail
 - Color : NT (Natural)



Pat Metheny SIGNATURE MODELS



- GB200 BST**
- 3pc GB Mahogany/ Maple set-in neck *Prestige*
 - Spruce top/Maple back/sides
 - Medium frets
 - Ebony bridge
 - GB200 tailpiece
 - Super 58 (H) neck pu
 - Super 58 (H) bridge pu
 - Hardware color : Gold
 - Scale : 628mm/24.75"
 - Depth : 80mm at tail
 - Color : BST (Brown Sunburst)



- GB15 TR**
- 3pc GB15 Maple set-in neck *Prestige*
 - Spruce top/Maple back/sides
 - Medium frets
 - Ebony bridge
 - GB15 tailpiece
 - GB special (H) neck pu
 - Hardware color : Cosmo Black
 - Scale : 628mm/24.75"
 - Depth : 75mm at tail
 - Color : TR (Transparent Red)



- GB10 BS**
- 3pc GB Maple set-in neck *Prestige*
 - Spruce top/Maple back/sides
 - Medium frets
 - Ebony bridge
 - GB10 tailpiece
 - GB special (H) neck pu
 - GB special (H) bridge pu
 - Hardware color : Gold
 - Scale : 628mm/24.75"
 - Depth : 65mm at tail
 - Colors : BS (Brown Sunburst)
NT (Natural)



- GB10 NT**
- 3pc GB Maple set-in neck *Prestige*
 - Spruce top/Maple back/sides
 - Medium frets
 - Ebony bridge
 - GB10 tailpiece
 - GB special (H) neck pu
 - GB special (H) bridge pu
 - Hardware color : Gold
 - Scale : 628mm/24.75"
 - Depth : 65mm at tail
 - Colors : BS (Brown Sunburst)
NT (Natural)



- JSM100 VT**
- JSM Mahogany set-in neck *Prestige*
 - Flamed Maple top/Maple back/sides
 - Jumbo frets
 - Gotoh®510BN bridge
 - Quik Change II tailpiece
 - Super 58 (H) neck pu
 - Super 58 (H) bridge pu
 - Hardware color : Gold
 - Scale : 628mm/24.75"
 - Depth : 43mm at tail
 - Color : VT (Vintage Sunburst)

John Scofield SIGNATURE MODEL

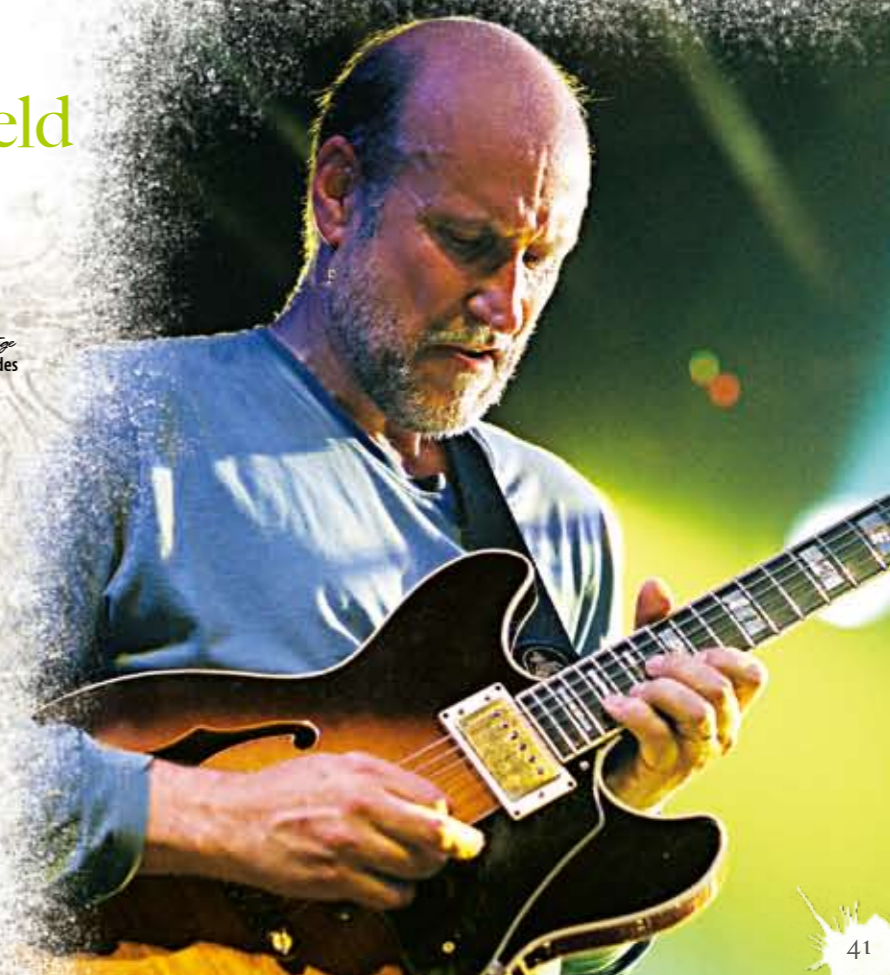

ARTCORE

The Artcore line represents a step forward in the evolution of affordable hollow body guitars. Since 2002, Ibanez has been producing these exquisite guitars that are at home in a jazz combo as well as a full-on rock show. Like many other Ibanez models, the Artcores are as versatile as they are beautiful. They come in a variety of sizes and hardware configurations to meet the needs of the one at a price fit for all.



Custom Fret Edge Treatment



ARTCORE Custom Neck
Artcore Custom models feature 5pc maple/walnut neck for extra strength and stability.

AF

The AF is the most traditional of the Artcore series. The traditional full-hollow construction means there are no sound blocks in the body. Producing rich and complex tones, the AF is the guitar for the purist in all of us.



U-Nam

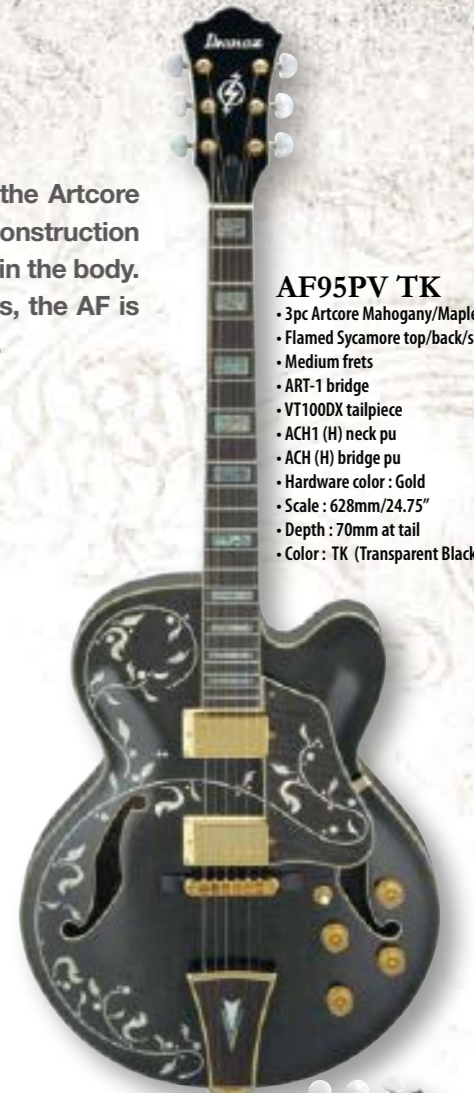

AF95PV TK
• 3pc Artcore Mahogany/Maple set-in neck
• Flamed Sycamore top/back/sides
• Medium frets
• ART-1 bridge
• VT100DX tailpiece
• ACH1 (H) neck pu
• ACH (H) bridge pu
• Hardware color : Gold
• Scale : 628mm/24.75"
• Depth : 70mm at tail
• Color : TK (Transparent Black)



AF125 AMB
• 5pc Artcore Maple/Walnut set-in neck
• Quilted Maple top/back/sides
• Medium frets
• ART-1 bridge
• VT04 Custom tailpiece
• Super 58 Custom (H) neck pu
• Super 58 Custom (H) bridge pu
• Hardware color : Gold
• Scale : 628mm/24.75"
• Depth : 70mm at tail
• Color : AMB (Amber Burst)



AF105 VB
• 5pc Artcore Maple/Walnut set-in neck
• Flamed Maple top/back/sides
• Medium frets
• ART-1 bridge
• VT04 Custom tailpiece
• Super 58 Custom (H) neck pu
• Super 58 Custom (H) bridge pu
• Hardware color : Gold
• Scale : 628mm/24.75"
• Depth : 70mm at tail
• Color : VB (Vintage Burst)



AK100 NT
• 5pc Artcore Maple/Walnut set-in neck
• Maple top/back/sides
• Medium frets
• ART-W wooden bridge
• VT60 tailpiece
• Super 58 Custom (H) neck pu
• Super 58 Custom (H) bridge pu
• Hardware color : Gold
• Scale : 628mm/24.75"
• Depth : 70mm at tail
• Color : NT (Natural)



AS103 VB
• 5pc Artcore Maple/Walnut set-in neck
• Flamed Maple top/back/sides
• Medium frets
• ART-1 bridge
• Quik Change III tailpiece
• Super 58 Custom (H) neck pu
• Super 58 Custom (H) bridge pu
• Hardware color : Gold
• Scale : 628mm/24.75"
• Depth : 43mm at tail
• Colors : VB (Vintage Burst)
NT (Natural)



AS103 NT
• 5pc Artcore Maple/Walnut set-in neck
• Flamed Maple top/back/sides
• Medium frets
• ART-1 bridge
• Quik Change III tailpiece
• Super 58 Custom (H) neck pu
• Super 58 Custom (H) bridge pu
• Hardware color : Gold
• Scale : 628mm/24.75"
• Depth : 43mm at tail
• Colors : VB (Vintage Burst)
NT (Natural)



VBF70 Vintage Vibrato

This old school vibrato adds country and rockabilly nuances to the rich tone of a full-hollow guitar, but the included roller saddles eliminate "old school" tuning problems.

*VBF70 Vintage Vibrato design licensed by Fred W. Gretsch Enterprises, Ltd. in the U.S.



AF95 VLS
• 3pc Artcore Mahogany/Maple set-in neck
• Flamed Sycamore top/back/sides
• Medium frets
• ART-1 bridge
• VT100DX tailpiece
• ACH1 (H) neck pu
• ACH2 (H) bridge pu
• Hardware color : Gold
• Scale : 628mm/24.75"
• Depth : 70mm at tail
• Color : VLS (Violin Sunburst)



AF75TDG IV
• Artcore Mahogany set-in neck
• Maple top/back/sides
• Medium frets
• ART-2 Roller bridge
• VBF70 vibrato
• ACH1 (H) neck pu
• ACH2 (H) bridge pu
• Hardware color : Gold
• Scale : 628mm/24.75"
• Depth : 70mm at tail
• Color : IV (Ivory)



AF75 BS
• Artcore Mahogany set-in neck
• Maple top/back/sides
• Medium frets
• ART-1 bridge
• VT60 tailpiece
• ACH1 (H) neck pu
• ACH2 (H) bridge pu
• Hardware color : Chrome
• Scale : 628mm/24.75"
• Depth : 70mm at tail
• Color : BS (Brown Sunburst)



Chris Camozzi
Michael Bolton

Eric Krasno
Soulive

AK

Jazz and blues history is filled with the warm tones of large hollow body guitars. The AK escapes from the bright sound of maple tops and metal bridges, replacing them with a spruce top and an all-wood bridge.



AK/20Frets

The traditional 20-fret fingerboard offers just the right placement of the neck pickup, for warmer tone.

AK80 BS

- 3pc Artcore Mahogany /Maple set-in neck
- Spruce top /Sycamore back/sides
- Medium frets
- ART-W wooden bridge
- VT60 tailpiece
- ACH1 (H) neck pu
- ACH2 (H) bridge pu
- Hardware color : Chrome
- Scale : 628mm/24.75"
- Depth : 70mm at tail
- Color : BS (Brown Sunburst)

AK95 DVS

- 3pc Artcore Mahogany/Maple set-in neck
- Spruce top/Sycamore back /sides
- Medium frets
- ART-W wooden bridge
- VT100DX tailpiece
- ACH1 (H) neck pu
- ACH2 (H) bridge pu
- Hardware color : Gold
- Scale : 628mm/24.75"
- Depth : 70mm at tail
- Color : DVS (Dark Violin Sunburst)

AG

The AG has a slightly smaller body width than the more traditional AF dimensions. However, the same depth and true full-hollow body construction make for a big standout sound.

AG75 BS

- Artcore Mahogany set-in neck
- Maple top/back/sides
- Medium frets
- ART-1 bridge
- VT60 tailpiece
- ACH1 (H) neck pu
- ACH2 (H) bridge pu
- Hardware color : Chrome
- Scale : 628mm/24.75"
- Depth : 70mm at tail
- Color : BS (Brown Sunburst)

AG96 DHS

- 3pc Artcore Mahogany /Maple set-in neck
- Flamed Maple top/back/sides
- Medium frets
- ART-1 bridge
- VT100DX tailpiece
- ACH1 (H) neck pu
- ACH2 (H) bridge pu
- Hardware color : Gold
- Scale : 628mm/24.75"
- Depth : 70mm at tail
- Color : DHS (Dark Honey Sunburst)

AFS

Pushing traditional concepts one step further, the Ibanez AFS has the same shape and full-hollow body of the AF. For increased comfort and more midrange punch, the body depth is one inch thinner. An Ibanez Vintage Vibrato is also mounted on the body with roller saddles, eliminating the tuning problems of traditional systems.

AFS75T TRD

- Artcore Mahogany set-in neck
- Maple top/back/sides
- Medium frets
- ART-2 Roller bridge
- VBF70 vibrato
- ACH1 (H) neck pu
- ACH2 (H) bridge pu
- Hardware color : Chrome
- Scale : 628mm/24.75"
- Depth : 43mm at tail
- Colors : TRD (Transparent Red) NWB (Neo Western Black)

AFS75T NWB

- Artcore Mahogany set-in neck
- Maple top/back/sides
- Medium frets
- ART-2 Roller bridge
- VBF70 vibrato
- ACH1 (H) neck pu
- ACH2 (H) bridge pu
- Hardware color : Chrome
- Scale : 628mm/24.75"
- Depth : 43mm at tail
- Colors : TRD (Transparent Red) NWB (Neo Western Black)

AFS95T MBU

- 3pc Artcore Mahogany /Maple set-in neck
- Flamed Sycamore top/back/sides
- Medium frets
- ART-2 Roller bridge
- VBF70 vibrato
- ACH1 (H) neck pu
- ACH2 (H) bridge pu
- Hardware color : Gold
- Scale : 628mm/24.75"
- Depth : 43mm at tail
- Color : MBU (Marine Blue)



AFS/Body Comparison

The AFS body features full-hollow construction, offering traditional jazz tone and midrange punch, yet it's thinner than traditional jazz boxes for easier playability.

AS The AS is a semi-acoustic guitar built to tackle just about any genre of music you throw at it. The pickups are mounted into a sustain block for increased sustain and feedback elimination. The Quik Change III bridge makes it easy to change strings without a lot of time involved.



AS93 VLS

- 3pc Artcore Mahogany/Maple set-in neck
- Flamed Sycamore top/back/sides
- Medium frets
- ART-1 bridge
- Quik Change III tailpiece
- ACH1 (H) neck pu
- ACH2 (H) bridge pu
- Hardware color : Gold
- Scale : 628mm/24.75"
- Depth : 43mm at tail
- Color : VLS (Violin Sunburst)



AS73B BKF

- Artcore Mahogany set-in neck
- Maple top/back/sides
- Medium frets
- ART-1 bridge
- Quik Change III tailpiece
- ACH1-S (H) neck pu
- ACH2-S (H) bridge up
- Hardware color : Chrome
- Scale : 628mm/24.75"
- Depth : 43mm at tail
- Color : BKF (Black Flat)



AS93PV TK

- 3pc Artcore Mahogany/Maple neck
- Flamed Sycamore top/back/sides
- Medium frets
- ART-1 bridge
- Quik Change III tailpiece
- ACH1 (H) neck pu
- ACH2 (H) bridge pu
- Hardware color : Gold
- Scale : 628mm/24.75"
- Depth : 43mm at tail
- Color : TK (Transparent Black)



AS73T TCR

- Artcore Mahogany set-in neck
- Maple top/back/sides
- Medium frets
- ART-2 Roller bridge
- VBS80 vibrato
- ACH1 (H) neck pu
- ACH2 (H) bridge pu
- Hardware color : Chrome
- Scale : 628mm/24.75"
- Depth : 43mm at tail
- Color : TCR (Transparent Cherry)

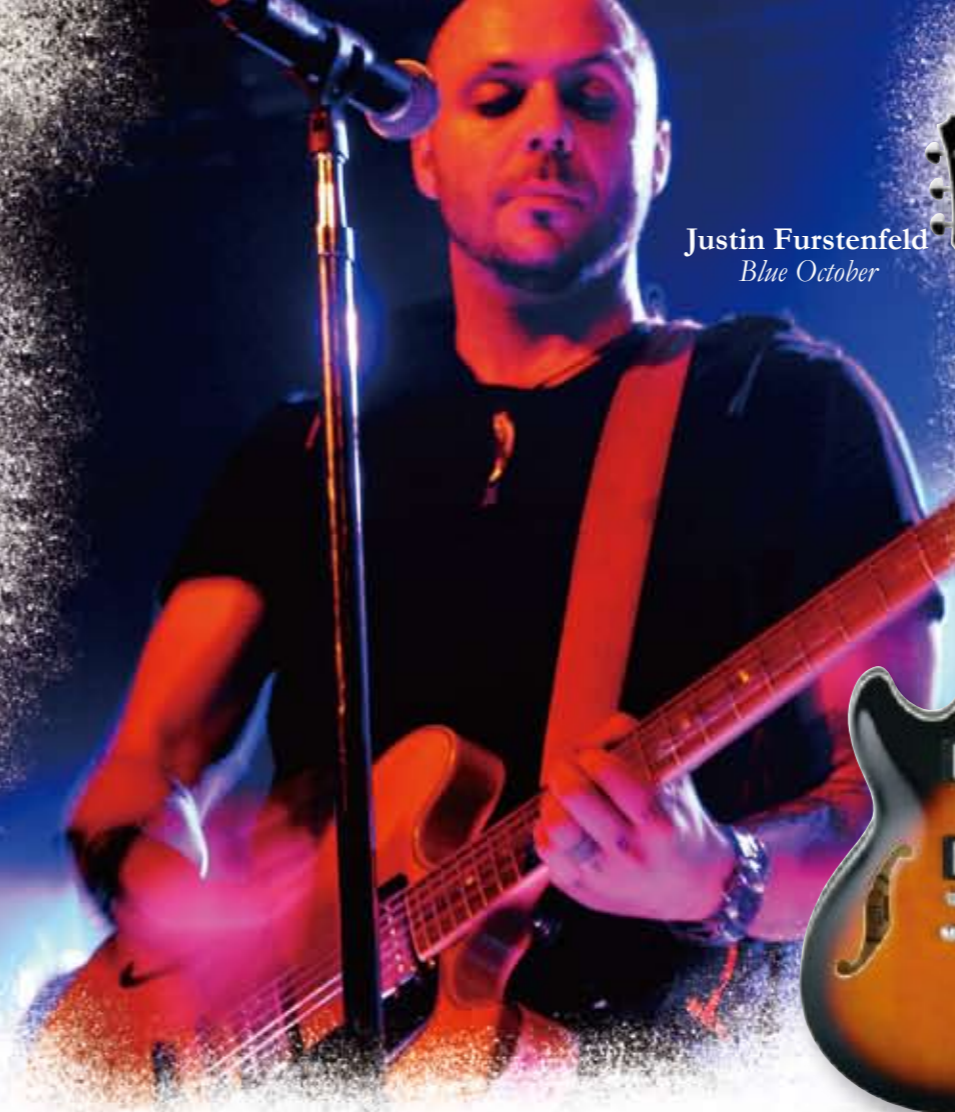

Justin Furstenfeld
Blue October



AS73 BS

- Artcore Mahogany set-in neck
- Maple top/back/sides
- Medium frets
- ART-1 bridge
- Quik Change III tailpiece
- ACH1 (H) neck pu
- ACH2 (H) bridge pu
- Hardware color : Chrome
- Scale : 628mm/24.75"
- Depth : 43mm at tail
- Colors : IV (Ivory)
BS (Brown Sunburst)



AS73 IV

- Artcore Mahogany set-in neck
- Maple top/back/sides
- Medium frets
- ART-1 bridge
- Quik Change III tailpiece
- ACH1 (H) neck pu
- ACH2 (H) bridge pu
- Hardware color : Chrome
- Scale : 628mm/24.75"
- Depth : 43mm at tail
- Colors : IV (Ivory)
BS (Brown Sunburst)

AMF

AMF is the newest model in the Artcore series. With AMF, Ibanez aims to bring the tones and looks of traditional hollow body guitars into more modern musical realms.



AMF73 TF

- Artcore Mahogany set-in neck
- Maple top/back/sides
- Medium frets
- ART-1 bridge
- ACH1-S (H) neck pu
- ACH2-S (H) bridge pu
- Hardware color : Chrome
- Scale : 628mm/24.75"
- Depth : 43mm at tail
- Colors : BK (Black)
TF (Tobacco Flat)



AMF73 BK

- Artcore Mahogany set-in neck
- Maple top/back/sides
- Medium frets
- ART-1 bridge
- ACH1-S (H) neck pu
- ACH2-S (H) bridge pu
- Hardware color : Chrome
- Scale : 628mm/24.75"
- Depth : 43mm at tail
- Colors : BK (Black)
TF (Tobacco Flat)

AMF/Body Thickness

The AMF body is flat-top and slender with semi-hollow construction, offering a bit more solid rock feel, yet warmer tone than a solid electric guitar.



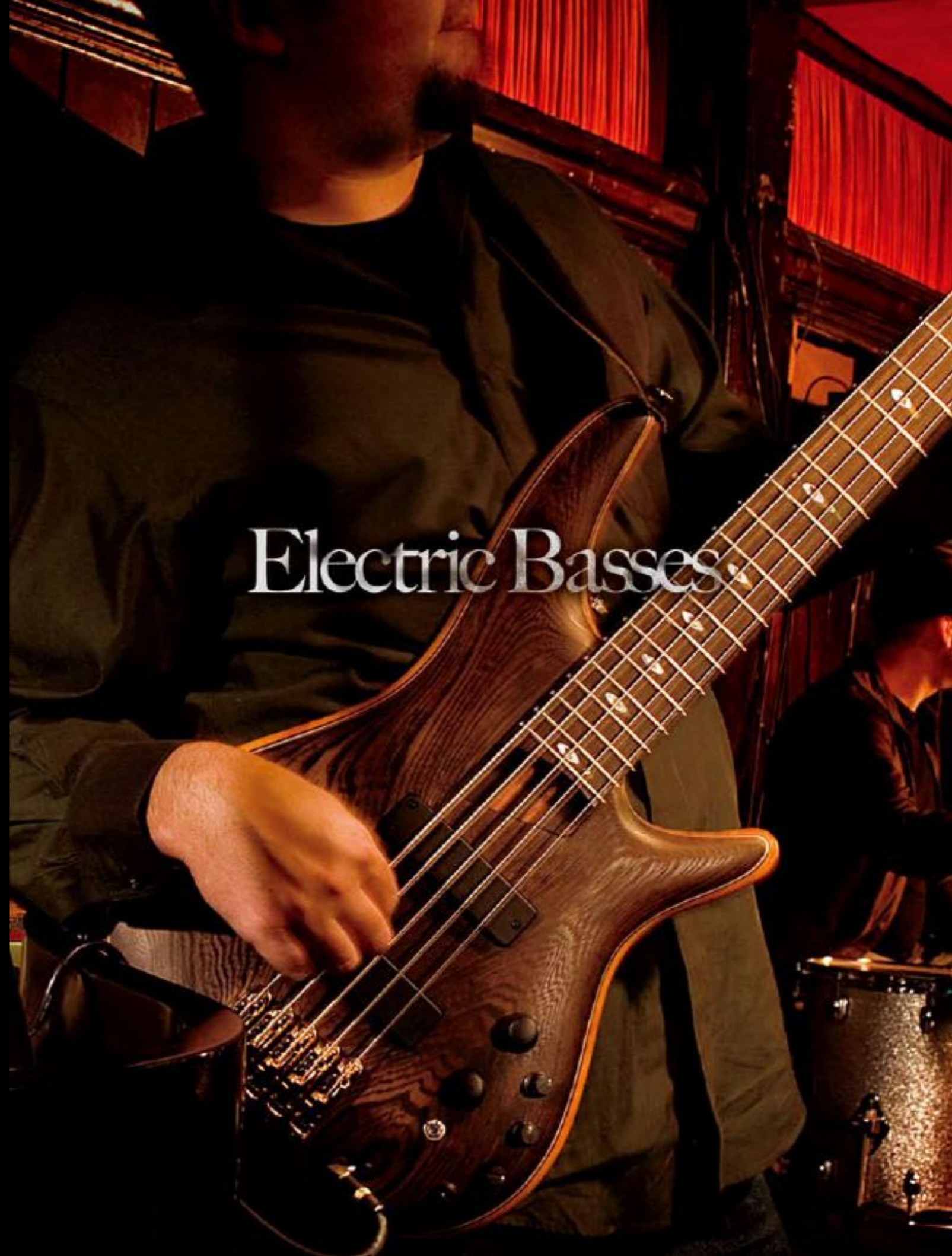

Electric Basses

SR *Prestige*

CRAFTED BY JAPAN'S FINEST LUTHIERS

The SR Prestige is the pinnacle of playing comfort, smart design and Japanese craftsmanship. All SR Prestige models are "Made in Japan" by the finest Ibanez craftsmen and from top-of-the-line components. They feature the Mono-Rail bridge design, with complete string-to-string isolation so that each string vibrates without interference from other strings, the newly developed Power Curve III EQ for vitalizing the low-end and midrange tones, and the same classic slim neck that has become an industry standard over the past 20 years.

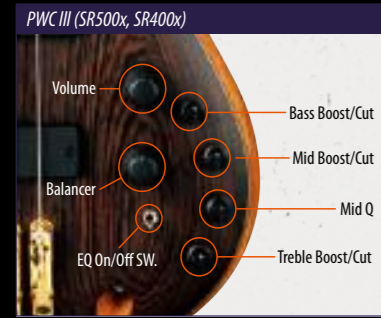

Power Curve III EQ (on SR Prestige)

The Power Curve III 3-band EQ was developed specifically for our SR Prestige line. The Mid Q control makes adjustment of the core of your bass – the mids – extremely simple, and the +/-12dB EQ variable range enables a more natural sounding bass tone. Equipped with an EQ On/Off switch that outputs directly from the Bartolini® pickup.



MR4 Mono-Rail Bridge

The Mono-Rail Bridge is the ultimate in string isolation for bass. Each saddle is independently and securely locked down to the body for maximum vibration transfer and no interference. One screw controls the height of each saddle for easy adjustment.

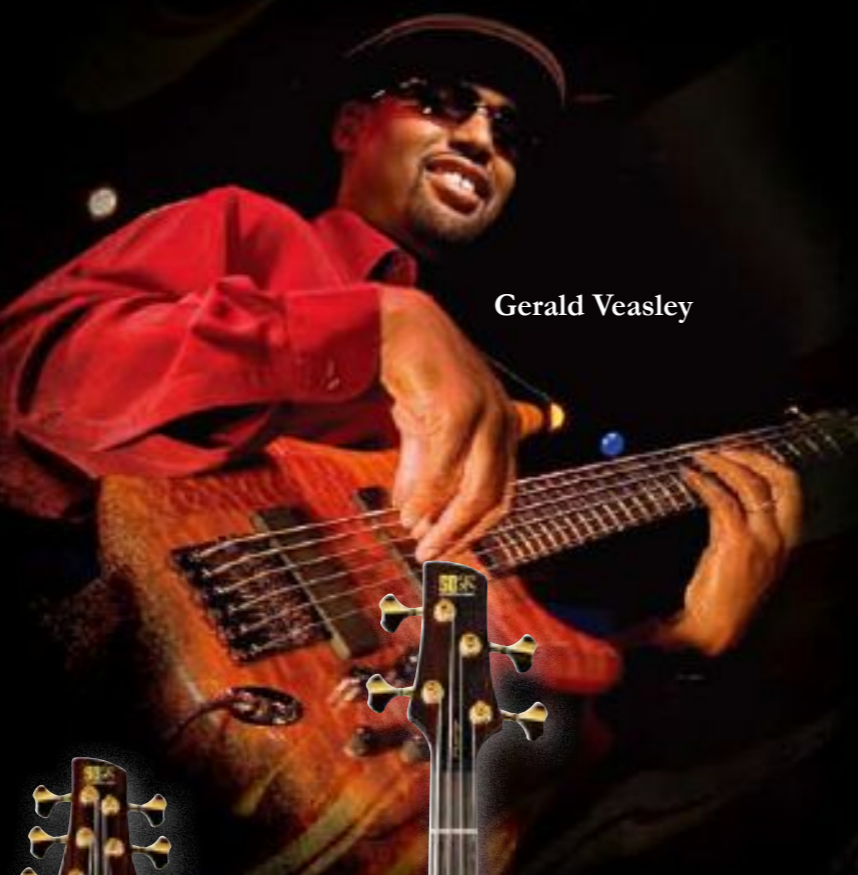

Gerald Veasley



SR5005E OL

- 5pc Atlas-5 HP Wenge /Bubinga neck *Prestige*
- w/KTS™ TITANIUM Reinforcement
- BLACK TUSQ XL® NUT
- Wenge/Mahogany/Wenge body
- Medium frets
- MR-4 bridge (16.5mm string spacing)
- USA Bartolini® Custom neck pu
- USA Bartolini® Custom bridge pu
- PWC III 3-band eq
- Elixir® strings
- Hardware color : Gold
- Scale : 864mm/34"
- Color : OL (Oil)

SR5006E OL

- 5pc Atlas-6 HP Wenge /Bubinga neck *Prestige*
- w/KTS™ TITANIUM Reinforcement
- BLACK TUSQ XL® NUT
- Wenge/Mahogany/Wenge body
- Medium frets
- MR-4 bridge (16.5mm string spacing)
- USA Bartolini® Custom neck pu
- USA Bartolini® Custom bridge pu
- PWC III 3-band eq
- Elixir® strings
- Hardware color : Gold
- Scale : 864mm/34"
- Color : OL (Oil)

SR5000E OL

- 5pc Atlas-4 HP Wenge /Bubinga neck *Prestige*
- w/KTS™ TITANIUM Reinforcement
- BLACK TUSQ XL® NUT
- Wenge/Mahogany/Wenge body
- Medium frets
- MR-4 bridge (19mm string spacing)
- USA Bartolini® Custom neck pu
- USA Bartolini® Custom bridge pu
- PWC III 3-band eq
- Elixir® strings
- Hardware color : Gold
- Scale : 864mm/34"
- Color : OL (Oil)



SR4000E SDR

- 5pc Atlas-4 HP Wenge /Bubinga neck *Prestige*
- w/KTS™ TITANIUM Reinforcement
- BLACK TUSQ XL® NUT
- Mahogany body
- Medium frets
- MR-4 bridge (19mm string spacing)
- USA Bartolini® Custom neck pu
- USA Bartolini® Custom bridge pu
- PWC III 3-band eq
- Elixir® strings
- Hardware color : Cosmo Black
- Scale : 864mm/34"
- Colors : SDR (Stained Red)
- TKF (Transparent Black Flat)

SR4000E TKF

- 5pc Atlas-4 HP Wenge /Bubinga neck *Prestige*
- w/KTS™ TITANIUM Reinforcement
- BLACK TUSQ XL® NUT
- Mahogany body
- Medium frets
- MR-4 bridge (19mm string spacing)
- USA Bartolini® Custom neck pu
- USA Bartolini® Custom bridge pu
- PWC III 3-band eq
- Elixir® strings
- Hardware color : Cosmo Black
- Scale : 864mm/34"
- Colors : SDR (Stained Red)
- TKF (Transparent Black Flat)

Stephane Barbe
Kataklysm

SR4005E TKF

- 5pc Atlas-5 HP Wenge /Bubinga neck *Prestige*
- w/KTS™ TITANIUM Reinforcement
- BLACK TUSQ XL® NUT
- Mahogany body
- Medium frets
- MR-4 bridge (16.5mm string spacing)
- USA Bartolini® Custom neck pu
- USA Bartolini® Custom bridge pu
- PWC III 3-band eq
- Elixir® strings
- Hardware color : Cosmo Black
- Scale : 864mm/34"
- Colors : SDR (Stained Red)
- TKF (Transparent Black Flat)

SR4005E SDR

- 5pc Atlas-5 HP Wenge /Bubinga neck *Prestige*
- w/KTS™ TITANIUM Reinforcement
- BLACK TUSQ XL® NUT
- Mahogany body
- Medium frets
- MR-4 bridge (16.5mm string spacing)
- USA Bartolini® Custom neck pu
- USA Bartolini® Custom bridge pu
- PWC III 3-band eq
- Elixir® strings
- Hardware color : Cosmo Black
- Scale : 864mm/34"
- Colors : SDR (Stained Red)
- TKF (Transparent Black Flat)



Jeanne Sagan
All That Remains





Glen Benton
Decide, Vital Remains



EQB IIIS on SR70x, SR60x and SR5xx
In addition to 3-band EQ, the SR is now equipped with a mid-frequency select switch, enabling you to instantly select 250Hz and 600Hz – the heart of the mid zone – for a more dynamic and ideal tone.



Matt Snell
Five Finger Death Punch



Ryan Wombacher
Bleeding Through



Dustin Davidson
August Burns Red
Photo by Cory Morton

SR 4 string



SR520 BK

- 5pc SR4 Maple/Rosewood neck
- Mahogany body
- Medium frets
- Accu-Cast B20 bridge (19mm string spacing)
- Bartolini® MK1 neck pu
- Bartolini® MK1 bridge pu
- EQB-IIIS 3-band eq
- Elixir® strings
- Hardware color : Cosmo Black
- Scale : 864mm/34"
- Color : BK (Black)

SR600 NTF

- 5pc SR4 Jatoba/Bubinga neck
- Ash body
- Medium frets
- Accu-Cast B20 bridge (19mm string spacing)
- Bartolini® MK1 neck pu
- Bartolini® MK1 bridge pu
- EQB-IIIS 3-band eq
- Elixir® strings
- Hardware color : Black Matt
- Scale : 864mm/34"
- Color : NTF (Natural Flat)

SR700 AM

- 5pc SR4 Jatoba/Bubinga neck
- Figured Maple/Mahogany wing body w/Maple center block
- Medium frets
- Accu-Cast B20 bridge (19mm string spacing)
- Bartolini® MK1 neck pu
- Bartolini® MK1 bridge pu
- EQB-IIIS 3-band eq
- Elixir® strings
- Hardware color : Cosmo Black
- Scale : 864mm/34"
- Colors : AM (Amber)
CN (Charcoal Brown)

SR700 CN

- 5pc SR4 Jatoba/Bubinga neck
- Figured Maple/Mahogany wing body w/Maple center block
- Medium frets
- Accu-Cast B20 bridge (19mm string spacing)
- Bartolini® MK1 neck pu
- Bartolini® MK1 bridge pu
- EQB-IIIS 3-band eq
- Elixir® strings
- Hardware color : Cosmo Black
- Scale : 864mm/34"
- Colors : AM (Amber)
CN (Charcoal Brown)



Bartolini® MK1 Pickups

The MK1 pickups are split coil designs that provides a very wide frequency range and enhanced definition for maximum accuracy. The Neck and Bridge pickups have equal response, like traditional single coils, but without the hum and noise.

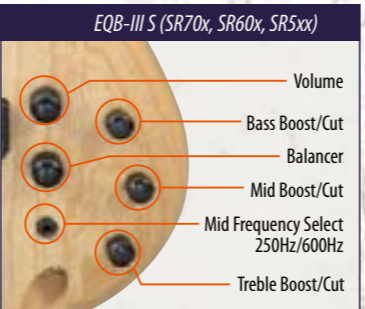

SR500 BM

- 5pc SR6 Jatoba/Bubinga neck
- Mahogany body
- Medium frets
- Accu-Cast B20 bridge (19mm string spacing)
- Bartolini® MK1 neck pu
- Bartolini® MK1 bridge pu
- EQB-IIIS 3-band eq
- Elixir® strings
- Hardware color : Cosmo Black
- Scale : 864mm/34"
- Color : BM (Brown Mahogany)

SR300 PW

- 5pc SR4 Maple/Rosewood neck
- Agathis body
- Medium frets
- B100 bridge (19mm string spacing)
- EXF-4F neck pu
- EXF-4R bridge pu
- EQB-IIIB Style Sweeper 3-band eq
- Hardware color : Cosmo Black
- Scale : 864mm/34"
- Colors : IPT (Iron Pewter)
PW (Pearl White)
ROM (Roadster Orange Metallic)

SR300 IPT

- 5pc SR4 Maple/Rosewood neck
- Agathis body
- Medium frets
- B100 bridge (19mm string spacing)
- EXF-4F neck pu
- EXF-4R bridge pu
- EQB-IIIB Style Sweeper 3-band eq
- Hardware color : Cosmo Black
- Scale : 864mm/34"
- Colors : IPT (Iron Pewter)
PW (Pearl White)
ROM (Roadster Orange Metallic)

SR300 ROM

- 5pc SR4 Maple/Rosewood neck
- Agathis body
- Medium frets
- B100 bridge (19mm string spacing)
- EXF-4F neck pu
- EXF-4R bridge pu
- EQB-IIIB Style Sweeper 3-band eq
- Hardware color : Cosmo Black
- Scale : 864mm/34"
- Colors : IPT (Iron Pewter)
PW (Pearl White)
ROM (Roadster Orange Metallic)

SR300L IPT

- Left-Handed
- 5pc SR4 Maple/Rosewood neck
- Agathis body
- Medium frets
- B100 bridge (19mm string spacing)
- EXF-4F neck pu
- EXF-4R bridge pu
- EQB-IIIB Style Sweeper 3-band eq
- Hardware color : Cosmo Black
- Scale : 864mm/34"
- Color : IPT (Iron Pewter)

Since 1987, musicians all over the world have come to know the playing comfort and unique sound of the SR bass. This year's lineup includes a wide array of options sure to fit just about any style of music. With 3-band EQ and its newly developed Mid-Frequency Select switch, or the Style Sweeper 3-band EQ controls, the SR basses can produce any sound you require.

Jatoba/Bubinga Slim Neck

Coupling Jatoba with Bubinga has made the neck strong and stable despite its thinness.





Marco Coti Zelati
Lacuna Coil



Karin Axelsson
Sonic Syndicate
Photo by Soile Siirtola

SR 5/6 string

3-Band EQ, Style Sweeper Controls

With the Style Sweeper 3-Band EQ controls, you can boost mids for a plucky finger sound or scoop them for a resonant slap sound with the turn of a knob.



SR705 TK

- 5pc SR5 Jatoba/Bubinga neck
- Figured Maple/Mahogany wing body w/Maple center block
- Medium frets
- Accu-Cast B25 bridge (16.5mm string spacing)
- Bartolini® MK1 neck pu
- Bartolini® MK1 bridge pu
- EQB-IIIS 3-band eq
- Elixir® strings
- Hardware color : Cosmo Black
- Scale : 864mm/34"
- Color : TK (Transparent Black)



SR605 NTF

- 5pc SR5 Jatoba/Bubinga neck
- Ash body
- Medium frets
- Accu-Cast B25 bridge (16.5mm string spacing)
- Bartolini® MK1 neck pu
- Bartolini® MK1 bridge pu
- EQB-IIIS 3-band eq
- Elixir® strings
- Hardware color : Black Matt
- Scale : 864mm/34"
- Color : NTF (Natural Flat)



SR505 BM

- 5pc SR5 Jatoba/Bubinga neck
- Mahogany body
- Medium frets
- Accu-Cast B25 bridge (16.5mm string spacing)
- Bartolini® MK1 neck pu
- Bartolini® MK1 bridge pu
- EQB-IIIS 3-band eq
- Elixir® strings
- Hardware color : Cosmo Black
- Scale : 864mm/34"
- Color : BM (Brown Mahogany)



SR506 BM

- 5pc SR6 Jatoba/Bubinga neck
- Mahogany body
- Medium frets
- B106 bridge (16.5mm string spacing)
- Bartolini® MK1 neck pu
- Bartolini® MK1 bridge pu
- EQB-IIIS 3-band eq
- Elixir® strings
- Hardware color : Cosmo Black
- Scale : 864mm/34"
- Color : BM (Brown Mahogany)



SR305 IPT

- 5pc SR5 Maple/Rosewood neck
- Agathis body
- Medium frets
- B105 bridge (16.5mm string spacing)
- EXF-SF neck pu
- EXF-SR bridge pu
- EQB-IIIB Style Sweeper 3-band eq
- Hardware color : Cosmo Black
- Scale : 864mm/34"
- Color : IPT (Iron Pewter)

Style Sweeper (SR30x)

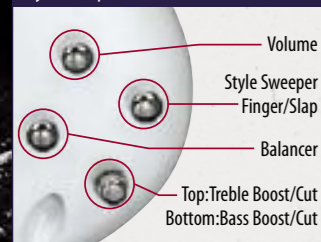

EDB

Every aspect of the EDB was designed with playing comfort in mind. The ergonomic body is contoured. The 5 piece Jatoba/Bubinga neck is exceptionally strong and slightly thicker than the SR bass. The EQB-II DX 2-band EQ makes any sound you want possible.



EDB550 BKF

- 5pc EDB4 Jatoba/Bubinga neck
- Ash body
- Medium frets
- B100 bridge (19mm string spacing)
- Duncan®/Ibanez neck pu
- Duncan®/Ibanez bridge pu
- EQB-II DX 2-band eq
- Elixir® strings
- Hardware color : Cosmo Black
- Scale : 864mm/34"
- Colors : BKF (Black Flat)
WNF (Walnut Flat)



EDB550 WNF

- 5pc EDB4 Jatoba/Bubinga neck
- Ash body
- Medium frets
- B100 bridge (19mm string spacing)
- Duncan®/Ibanez neck pu
- Duncan®/Ibanez bridge pu
- EQB-II DX 2-band eq
- Elixir® strings
- Hardware color : Cosmo Black
- Scale : 864mm/34"
- Colors : BKF (Black Flat)
WNF (Walnut Flat)



EDB555 WNF

- 5pc EDB5 Jatoba/Bubinga neck
- Ash body
- Medium frets
- B105 bridge (16.5mm string spacing)
- Duncan®/Ibanez neck pu
- Duncan®/Ibanez bridge pu
- EQB-II DX 2-band eq
- Elixir® strings
- Hardware color : Cosmo Black
- Scale : 864mm/34"
- Color : WNF (Walnut Flat)

Scooped-out

Scooped-out front for slapping and popping.



Duncan®/IBZ Pickups

Duncan®/Ibanez pickups on EDB550s.



GSR

There are wide variations among our GSR series guitars. The GSR200 combines straight ahead sounds with the high playability of an SR. The GSR200EX gives a punchier sound, and the GSR180 produces delicate but strong tones. Our Jumpstart Bass Package (see also P. 68) features a GSR electric bass and all the accessories you need to get up and jamming right from your first day.



GSR200EX GSF

- GSR4 Maple neck
- Nato body
- Medium frets
- B10 bridge (19mm string spacing)
- PPD4 neck pu
- PPD4 bridge pu
- Phat II eq
- Hardware color : Black
- Scale : 864mm/34"
- Colors : BKF (Black Flat)
- GSF (Green Shadow Flat)



GSR200EX BKF

- GSR4 Maple neck
- Nato body
- Medium frets
- B10 bridge (19mm string spacing)
- PPD4 neck pu
- PPD4 bridge pu
- Phat II eq
- Hardware color : Black
- Scale : 864mm/34"
- Colors : BKF (Black Flat)
- GSF (Green Shadow Flat)



GSR200 TR

- GSR4 Maple neck
- Agathis body
- Medium frets
- B10 bridge (19mm string spacing)
- PSNDP neck pu
- PSNDJ bridge pu
- Phat II eq
- Hardware color : Chrome
- Scale : 864mm/34"
- Color : BK (Black)
- JB (Jewel Blue)
- PW (Pearl White)
- TR (Transparent Red)



GSR200L BK

- Left-Handed
- GSR4 Maple neck
- Agathis body
- Medium frets
- B10 bridge (19mm string spacing)
- PSNDP neck pu
- PSNDJ bridge pu
- Phat II eq
- Hardware color : Chrome
- Scale : 864mm/34"
- Color : BK (Black)



GSR205 BK

- GSR5 Maple neck
- Agathis body
- Medium frets
- B15 bridge (16.5mm string spacing)
- DXH-5 neck pu
- DXH-5 bridge pu
- Phat II eq
- Hardware color : Chrome
- Scale : 864mm/34"
- Color : BK (Black)



GSR200 PW

- GSR4 Maple neck
- Agathis body
- Medium frets
- B10 bridge (19mm string spacing)
- PSNDP neck pu
- PSNDJ bridge pu
- Phat II eq
- Hardware color : Chrome
- Scale : 864mm/34"
- Color : BK (Black)
- JB (Jewel Blue)
- PW (Pearl White)
- TR (Transparent Red)



GSR200 BK

- GSR4 Maple neck
- Agathis body
- Medium frets
- B10 bridge (19mm string spacing)
- PSNDP neck pu
- PSNDJ bridge pu
- Phat II eq
- Hardware color : Chrome
- Scale : 864mm/34"
- Color : BK (Black)
- JB (Jewel Blue)
- PW (Pearl White)
- TR (Transparent Red)



GSR200 JB

- GSR4 Maple neck
- Agathis body
- Medium frets
- B10 bridge (19mm string spacing)
- PSNDP neck pu
- PSNDJ bridge pu
- Phat II eq
- Hardware color : Chrome
- Scale : 864mm/34"
- Color : BK (Black)
- JB (Jewel Blue)
- PW (Pearl White)
- TR (Transparent Red)



GSR180 MGT

- GSR4 Maple neck
- Agathis body
- Medium frets
- B10 bridge (19mm string spacing)
- PSNDJ neck pu
- PSNDJ bridge pu
- Hardware color : Chrome
- Scale : 864mm/34"
- Colors : BK (Black)
- BS (Brown Sunburst)
- MGT (Magenta)



GSR180 BS

- GSR4 Maple neck
- Agathis body
- Medium frets
- B10 bridge (19mm string spacing)
- PSNDJ neck pu
- PSNDJ bridge pu
- Hardware color : Chrome
- Scale : 864mm/34"
- Colors : BK (Black)
- BS (Brown Sunburst)
- MGT (Magenta)



GSR180 BK

- GSR4 Maple neck
- Agathis body
- Medium frets
- B10 bridge (19mm string spacing)
- PSNDJ neck pu
- PSNDJ bridge pu
- Hardware color : Chrome
- Scale : 864mm/34"
- Colors : BK (Black)
- BS (Brown Sunburst)
- MGT (Magenta)

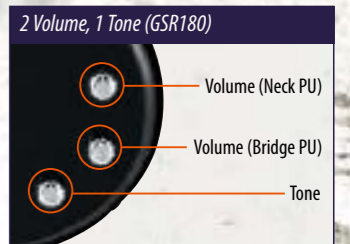
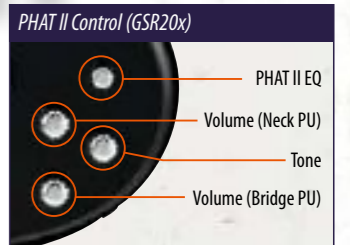

SRX

The SRX is the muscular big brother of the SR series. This is a bass that was designed for heavier playing styles, and it meets that demand in a no-nonsense layout. The EQB-II DX 2-band EQ makes it easy to find various sounds, and the now-famous stock Ibanez PFR pickups, which major artists rave about, are right there to give you that extra punch.

Joe Payne
Divine Heresy

Carol Kaye

Carol Kaye

SRX720 BKF

- 5pc SRX4 Maple /Walnut neck-thru
- Mahogany wing body
- Medium frets
- Accu-Cast B200 bridge (19mm string spacing)
- PFR-ALN4 neck pu
- PFR-ALB4 bridge pu
- EQB-II DX 2-band eq
- Elixir® strings
- Hardware color: Black
- Scale: 864mm/34"
- Color: BKF (Black Flat)

SRX725 BKF

- 5pc SRX5 Maple/Walnut neck-thru
- Mahogany wing body
- Medium frets
- Accu-Cast B205 bridge (18mm string spacing)
- PFR-ALN5 neck pu
- PFR-ALB5 bridge pu
- EQB-II DX 2-band eq
- Elixir® strings
- Hardware color: Black
- Scale: 864mm/34"
- Color: BKF (Black Flat)

Neck-Thru Construction (SRX72x)

Neck-thru construction on the SRX720s offers massive sustain and maximizes playability.



PFR Pickups and EQB-II DX EQ

These powerful full-range passive pickups generate high output with extra low midrange punch. The EQB-II DX 2-band EQ enhances heavy tones with simple operation.



Accu-Cast B20x Bridge

The B200 bridge provides SRX basses with massive, low-mid sound.

EQB-II DX (SRX)

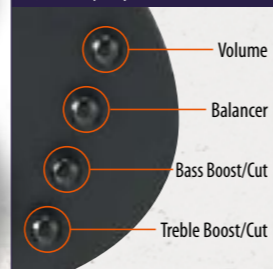

SRX430 RD

- 3pc SRX4 Maple neck
- Mahogany body
- Medium frets
- Accu-Cast B200 bridge (19mm string spacing)
- PFR-N4 neck pu
- PFR-B4 bridge pu
- EQB-II DX 2-band eq
- Elixir® strings
- Hardware color: Black
- Scale: 864mm/34"
- Colors: RD (Red)
- Color: WH (White)

SRX430 WH

- 3pc SRX4 Maple neck
- Mahogany body
- Medium frets
- Accu-Cast B200 bridge (19mm string spacing)
- PFR-N4 neck pu
- PFR-B4 bridge pu
- EQB-II DX 2-band eq
- Elixir® strings
- Hardware color: Black
- Scale: 864mm/34"
- Colors: RD (Red)
- Color: WH (White)

Nelson Braxton
The Braxton Brothers,
Michael Bolton

Fredrik Larsson
HammerFall

SRX360 BK

- 3pc SRX4 Maple neck
- Mahogany body
- Medium frets
- Accu-Cast B200 bridge (19mm string spacing)
- PFR-N4 neck pu
- PFR-B4 bridge pu
- EQB-II DX 2-band eq
- Hardware color: Chrome
- Scale: 864mm/34"
- Color: BK (Black)

SRX365 TGY

- 3pc SRX5 Maple neck
- Mahogany body
- Medium frets
- Accu-Cast B205 bridge (18mm string spacing)
- PFR-N5 neck pu
- PFR-B5 bridge pu
- EQB-II DX 2-band eq
- Hardware color: Chrome
- Scale: 864mm/34"
- Color: TGY (Titanium Gray)

ICB

The Iceman has long been one of the more adventurous body styles from Ibanez. In the bass world, it means a massive piece of mahogany and high-powered pickups to create tones that are absolutely earth shattering.

Anders Iwers
Tiamat

ICB300EX BK

- 3pc ICB4 Maple neck
- Mahogany body
- Medium frets
- Accu-Cast B200 bridge (19mm string spacing)
- PFR-N4 neck pu (black pole piece)
- PFR-B4 bridge pu (black pole piece)
- EQB-II DX 2-band eq
- Elixir® strings
- Hardware color: Black
- Scale: 864mm/34"
- Color: BK (Black)
- Color: WH (White)

EQB-II DX (ICB300, SDB)

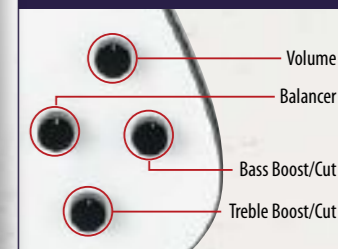

ICB300EX WH

- 3pc ICB4 Maple neck
- Mahogany body
- Medium frets
- Accu-Cast B200 bridge (19mm string spacing)
- PFR-N4 neck pu (black pole piece)
- PFR-B4 bridge pu (black pole piece)
- EQB-II DX 2-band eq
- Elixir® strings
- Hardware color: Black
- Scale: 864mm/34"
- Color: BK (Black)
- Color: WH (White)

PFR Pickups and EQB-II DX EQ

These powerful full-range passive pickups generate high output with extra low midrange punch. The EQB-II DX 2-band EQ enhances heavy tones with simple operation.



BTB

The concepts behind boutique basses are often the justification for making them extremely expensive. With the advent of the BTB however, Ibanez decided that these same concepts of well-selected body materials, 35" neck scale, and deep cutaways could be applied to an instrument that anyone could afford. All the BTBs feature neck-thru construction and deeper cutaways for enhanced playability and balance. This year, new BTB 700DXs, featuring EMG® pickups, join the lineup (other models feature Bartolini® MK2 pickups with EQ).



Mark Davis
Emmure



Lee Foral
After the Burial

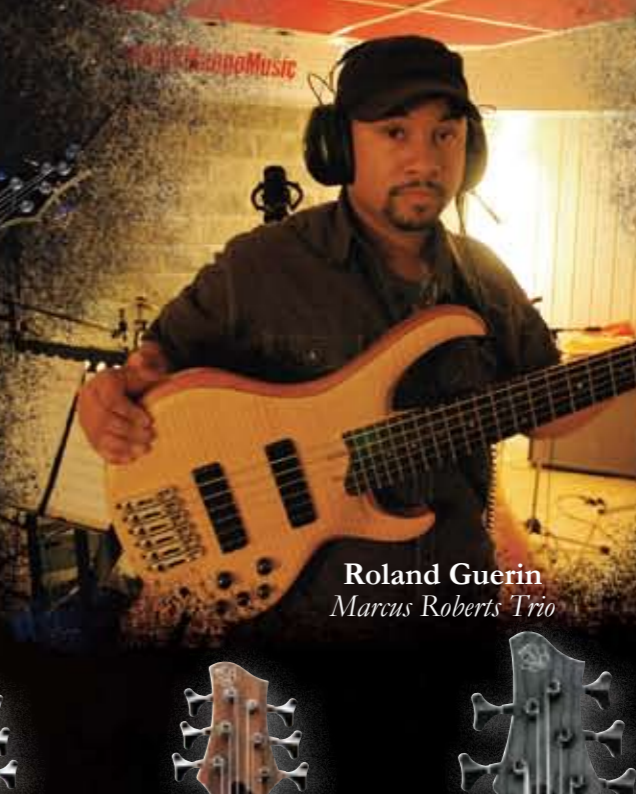

Roland Guerin
Marcus Roberts Trio

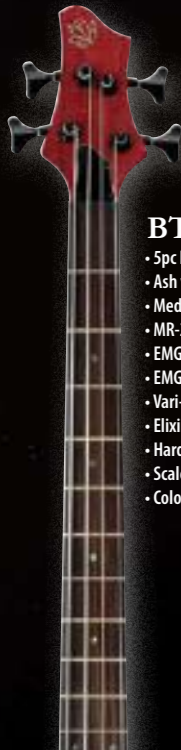
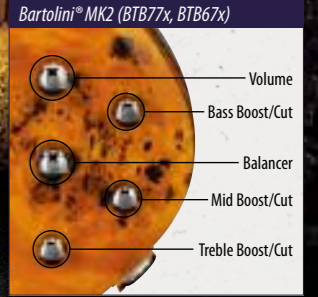
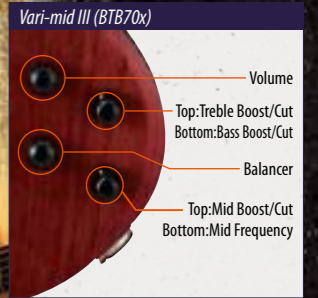

BTB700DX BWF

- 5pc BTB4 Maple/Bubinga neck-thru
- Ash wing body
- Medium frets
- MR-2 bridge (19mm string spacing)
- EMG® 40DC neck pu
- EMG® 40DC bridge pu
- Vari-mid III 3-band eq
- Elixir® strings
- Hardware color : Black
- Scale : 889mm/35"
- Colors : BWF (Burgundy Wine Flat) TKF (Transparent Black Flat)

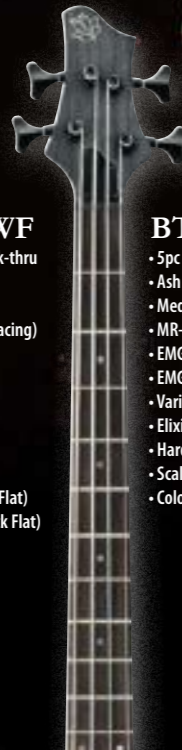

BTB700DX TKF

- 5pc BTB4 Maple/Bubinga neck-thru
- Ash wing body
- Medium frets
- MR-2 bridge (19mm string spacing)
- EMG® 40DC neck pu
- EMG® 40DC bridge pu
- Vari-mid III 3-band eq
- Elixir® strings
- Hardware color : Black
- Scale : 889mm/35"
- Colors : BWF (Burgundy Wine Flat) TKF (Transparent Black Flat)

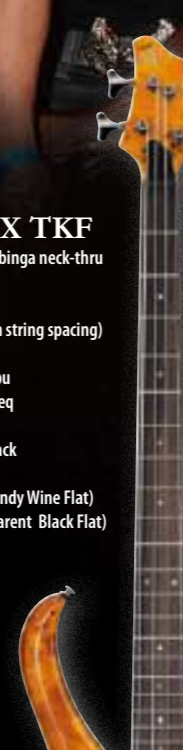

BTB770PB AM

- 5pc BTB4 Maple /Bubinga neck-thru
- Poplar Burl top
- Mahogany wing body
- Medium frets
- MR-2 bridge (19mm string spacing)
- Bartolini® MK2 neck pu
- Bartolini® MK2 bridge pu
- Bartolini® MK2 3-band eq
- Bartolini® MK2 3-band eq
- Elixir® strings
- Hardware color : Cosmo Black
- Scale : 889mm/35"
- Color : AM (Amber)

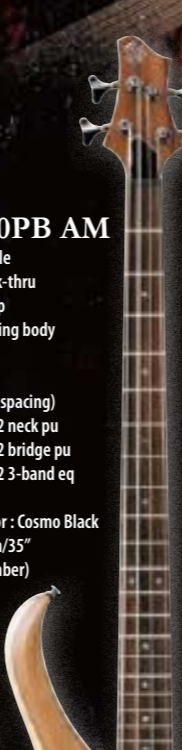

BTB670 NTF

- 5pc BTB4 Maple /Bubinga neck-thru
- Walnut/Ash wing body
- Medium frets
- MR-2 bridge (19mm string spacing)
- MR-2 bridge (19mm string spacing)
- Bartolini® MK2 neck pu
- Bartolini® MK2 bridge pu
- Bartolini® MK2 3-band eq
- Elixir® strings
- Hardware color : Cosmo Black
- Scale : 889mm/35"
- Color : NTF (Natural Flat)



BTB775PB CN

- 5pc BTB5 Maple /Bubinga neck-thru
- Poplar Burl top
- Mahogany wing body
- Medium frets
- MR-2 bridge (19mm string spacing)
- MR-2 bridge (19mm string spacing)
- Bartolini® MK2 neck pu
- Bartolini® MK2 bridge pu
- Bartolini® MK2 3-band eq
- Bartolini® MK2 3-band eq
- Elixir® strings
- Hardware color : Cosmo Black
- Scale : 889mm/35"
- Color : CN (Charcoal Brown)

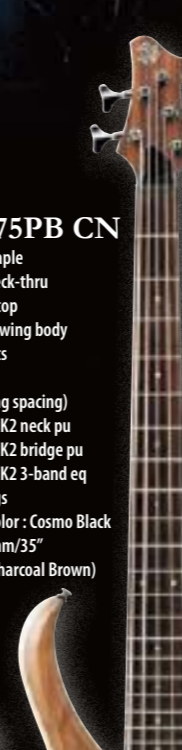

BTB675 NTF

- 5pc BTB5 Maple /Bubinga neck-thru
- Walnut/Ash wing body
- Medium frets
- MR-2 bridge (19mm string spacing)
- Bartolini® MK2 neck pu
- Bartolini® MK2 bridge pu
- Bartolini® MK2 3-band eq
- Elixir® strings
- Hardware color : Cosmo Black
- Scale : 889mm/35"
- Color : NTF (Natural Flat)

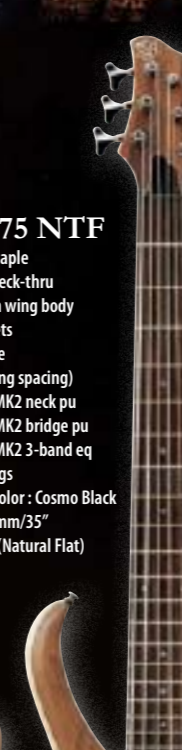

BTB676 NTF

- 5pc BTB6 Maple /Bubinga neck-thru
- Walnut/Ash wing body
- Medium frets
- MR-2 bridge (17mm string spacing)
- Bartolini® MK2 neck pu
- Bartolini® MK2 bridge pu
- Bartolini® MK2 3-band eq
- Elixir® strings
- Hardware color : Cosmo Black
- Scale : 889mm/35"
- Color : NTF (Natural Flat)



Neck-Thru Construction

Neck-thru construction on the BTB-series provides massive sustain and playing comfort.

BTB705DX TKF

- 5pc BTB5 Maple/Bubinga neck-thru
- Ash wing body
- Medium frets
- MR-2 bridge (19mm string spacing)
- EMG® 40DC neck pu
- EMG® 40DC bridge pu
- Vari-mid III 3-band eq
- Elixir® strings
- Hardware color : Black
- Scale : 889mm/35"
- Color : TKF (Transparent Black Flat)



BTB70x/EMG® Pickups

The EMG® 40DC pickups produce a deep low end while maintaining clarity with very low noise.



Bartolini® MK2 Pickups and EQ

The MK2 pickups are quad coil designs. The Neck pickup tone is very deep and the Bridge pickup tone is bright, just like the US made pickups. They are also balanced for output so that the deep tone Neck pickup does not overpower the Bridge pickup. The MK2 electronics compliments and enhances their wide tonal range.

ATK

The ATK may be the most straightforward bass in the entire Ibanez line. This simple rock n' roll bass with a punk attitude combines a large ash body with a maple neck for big, tight sounds. The special ATK triple coil pickups can only be found on these basses. Coupled with the 3-band EQ, this bass can generate some serious low-end punch.



ATK310 SOB

- 3pc ATK4 Maple neck
- Ash body
- Jumbo frets
- ATK4 bridge (19mm string spacing)
- ATK Triple coil pu
- ATK 3-band eq
- Elixir® strings
- Hardware color : Chrome
- Scale : 864mm/34"
- Colors : BK (Black)

MGR (Mint Green)
SOB (Soda Blue)
WH (White)



ATK310 WH

- 3pc ATK4 Maple neck
- Ash body
- Jumbo frets
- ATK4 bridge (19mm string spacing)
- ATK Triple coil pu
- ATK 3-band eq
- Elixir® strings
- Hardware color : Chrome
- Scale : 864mm/34"
- Colors : BK (Black)

MGR (Mint Green)
SOB (Soda Blue)
WH (White)

ATK300 NT

- 3pc ATK4 Maple neck
- Ash body
- Jumbo frets
- ATK4 bridge (19mm string spacing)
- ATK Triple coil pu
- ATK 3-band eq
- Elixir® strings
- Hardware color : Chrome
- Scale : 864mm/34"
- Color : NT (Natural)

MGR (Mint Green)
SOB (Soda Blue)
WH (White)



ATK310 MGR

- 3pc ATK4 Maple neck
- Ash body
- Jumbo frets
- ATK4 bridge (19mm string spacing)
- ATK Triple coil pu
- ATK 3-band eq
- Elixir® strings
- Hardware color : Chrome
- Scale : 864mm/34"
- Colors : BK (Black)

MGR (Mint Green)
SOB (Soda Blue)
WH (White)



ATK Bridge

The ATK's iconic, metal-plated bridge is capable of producing a bright, high-end, massive attack. It also allows the option of playing more through the body for enhanced low-end and more sustain.

ATK310 BK

- 3pc ATK4 Maple neck
- Ash body
- Jumbo frets
- ATK4 bridge (19mm string spacing)
- ATK Triple coil pu
- ATK 3-band eq
- Elixir® strings
- Hardware color : Chrome
- Scale : 864mm/34"
- Colors : BK (Black)

MGR (Mint Green)
SOB (Soda Blue)
WH (White)

ATK Triple Coil Pickup

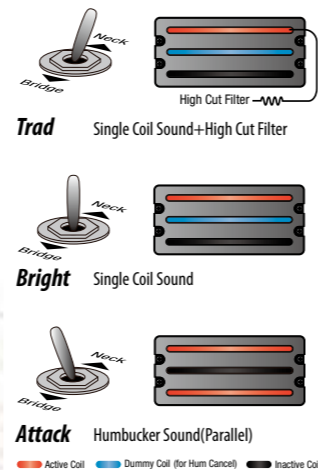

ATK 3 BAND EQ (ATK, PGB)

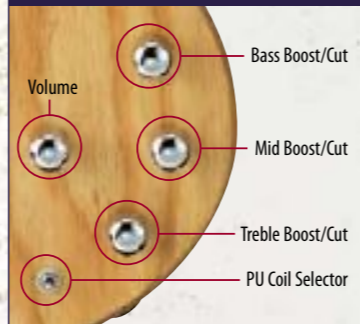

Adam Blackstone
*Kanye West,
Janet Jackson*

Mike Murphy
Haste The Day
photo by Bryan Minear

John 'Slo' Maggard
Unearth

Skinny Disco
Deathstars

JTKB

If you want a bass that transports you back to hot rods and 60's rock n' roll, then the JTKB is your golden ticket. Its mahogany body, high-powered pickups and solid bridge can take a beating and still produce the warm, smooth sound of a vintage bass. This year, the new JTKB300, featuring three single pickups, joins the lineup. The JTKB is truly unique among Ibanez basses.



JTKB300 WH

- 3pc JTKB Maple neck
- Mahogany body
- Medium frets
- JTB10 bridge (19mm string spacing)
- PSJ neck pu
- PSJ mid pu
- PSJ bridge pu
- Elixir® strings
- Hardware color : Chrome
- Scale : 864mm/34"
- Color : WH (White)



PSJ Pickups

JTKB300 features three single pickups, each with its own on/off switch, enabling seven variable selections and a wide range of sound possibilities.

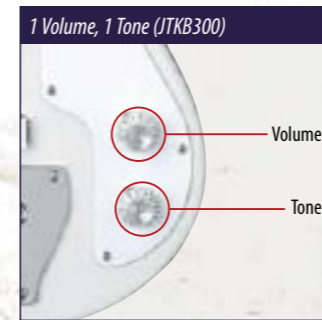

JTKB200 BS

- 3pc JTKB Maple neck
- Mahogany body
- Medium frets
- JTB10 bridge (19mm string spacing)
- ACHB-2 neck pu
- ACHB-2 bridge pu
- Elixir® strings
- Hardware color : Chrome
- Scale : 864mm/34"
- Color : BS (Brown Sunburst)

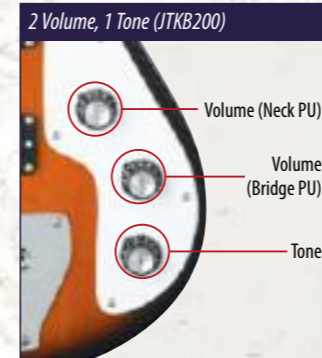

ARTB

For those who prefer a bass that has a more classic feel to it, the ARTB is a 70's style rock machine. The combination of mahogany body, 30" short scale length and set neck create a warm tone that recreates the days of arena rock. The short scale neck is also comfortable for smaller hands.

2 Volume, 1 Tone (ARTB)

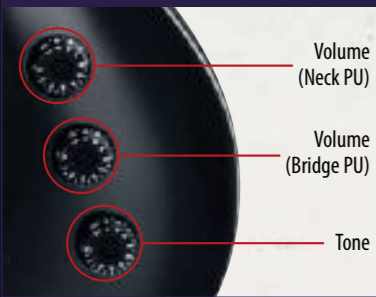

Volume (Neck PU)
Volume (Bridge PU)
Tone



ARTB100 BK

- 3pc ARTB Mahogany /Maple set-in neck
- Mahogany body
- Medium frets
- Gibraltar III bass bridge (19mm string spacing)
- Quik Change III bass tailpiece
- ACHB-2 neck pu
- ACHB-2 bridge pu
- D'Addario® Strings
- Hardware color : Chrome
- Scale : 770mm/30.3"
- String Gauge: .050/.070/.085/.105
- Colors : BK (Black) WH (White)

ARTB100 WH

- 3pc ARTB Mahogany /Maple set-in neck
- Mahogany body
- Medium frets
- Gibraltar III bass bridge (19mm string spacing)
- Quik Change III bass tailpiece
- ACHB-2 neck pu
- ACHB-2 bridge pu
- D'Addario® Strings
- Hardware color : Chrome
- Scale : 770mm/30.3"
- String Gauge: .050/.070/.085/.105
- Colors : BK (Black) WH (White)

ARTCORE

The Artcore Bass series was designed for players that are used to solid body basses but want the acoustic tone of a hollow body. The 30" scale neck increases playing comfort, and the acoustic body widens the palette of sounds at your disposal.

AFB200 BS

- 3pc Artcore Bass Mahogany /Maple set-in neck
- Maple top/back/sides
- Medium frets
- Wooden bridge (19mm string spacing)
- FBT40 tailpiece
- ACHB-2 neck pu
- ACHB-2 bridge pu
- D'Addario® Strings
- Hardware color : Gold
- Scale : 770mm/30.3"
- Depth: 70mm at tail
- String Gauge: .050/.070/.085/.105
- Color : BS (Brown Sunburst)

1 Volume, 1 Tone (ARTCORE)

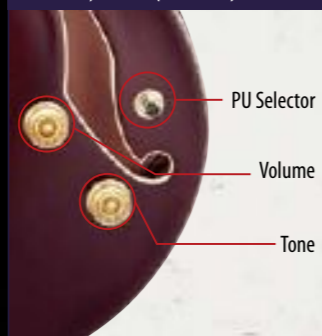

PU Selector
Volume
Tone



AGB200 TBR

- 3pc Artcore Bass Mahogany /Maple set-in neck
- Maple top/back/sides
- Medium frets
- Gibraltar III bass bridge (19mm string spacing)
- Quik Change III bass tailpiece
- ACHB-2 neck pu
- ACHB-2 bridge pu
- D'Addario® Strings
- Hardware color : Gold
- Scale : 770mm/30.3"
- Depth: 43mm at tail
- String Gauge: .050/.070/.085/.105
- Color : TBR (Transparent Brown)



TRIPHASIC Gary Willis SIGNATURE MODELS

KORN Fieldy SIGNATURE MODEL



GWB35 BKF

- 3pc GWB35 Maple neck
- Basswood body
- Fretless
- B105 bridge (16.5mm string spacing)
- SFR-GWB custom wound pu
- EQB-GWII 2-band eq
- D'Addario® Strings
- Hardware color : Black
- Scale : 864mm/34"
- Color : BKF (Black Flat)

GWB1005 NTF

- 3pc GWB1005 Maple neck *Prestige*
- Swamp Ash body
- Fretless
- STD-5 bridge (16.5mm string spacing)
- Bartolini® GWB pu
- Bartolini® NTBT 2-band eq
- D'Addario® Strings
- Hardware color : Black
- Scale : 864mm/34"
- Color : NTF (Natural Flat)

K5 TKF

- 5pc K5 Maple/Bubinga neck
- Mahogany body
- Medium frets
- Die-Cast EB-7 bridge (16.5mm string spacing)
- ADXSN neck pu
- ADXSB bridge pu
- Vari-Mid III 3-band eq
- Elixir® strings
- Hardware color : Gold
- Scale : 864mm/34"
- Color : TKF (Transparent Black Flat)



Die-Cast EB-7 bridge

The K5's lightweight bridge allows for more vigorous performance without compromising low-end sustain.

Vari-Mid III (K5)

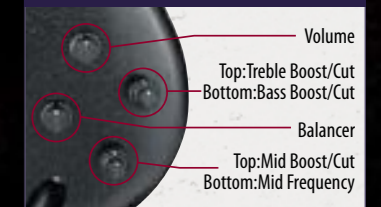

Volume
Top:Treble Boost/Cut
Bottom:Bass Boost/Cut
Balancer
Top:Mid Boost/Cut
Bottom:Mid Frequency

Bartolini® NTBT (GWB1005)

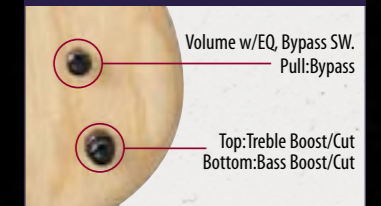

Volume w/EQ, Bypass SW.
Pull:Bypass
Top:Treble Boost/Cut
Bottom:Bass Boost/Cut

EQB-GWII (GWB35)



Volume
Top:Treble Boost/Cut
Bottom:Bass Boost/Cut



SLIPKNOT
Paul Gray
SIGNATURE
MODELS

Photo by Scott Uchida



Peter Iwers' Signature PIB1BK features 2 Bartolini® Custom pickups.



Back view of Peter Iwers' PIB1BK which features a 5pc maple/bubinga PIB4 thru-neck for increased sustain.



PGB1 BGW

- 3pc PGB Maple neck
- Ash body
- Jumbo frets
- ATK4 bridge (19mm string spacing)
- ATK triple coil pu
- ATK 3-band eq
- D'Addario® Strings
- Hardware color : Cosmo Black
- Scale : 864mm/34"
- Factory Tuning : 1D, 2A, 3E, 4B
- String Gauge : .050/ .070/ .090/ .110
- Color : BGW (Burgundy Wine)



PGB1L BGW

- Left-Handed
- 3pc PGB Maple neck
- Ash body
- Jumbo frets
- ATK4 bridge (19mm string spacing)
- ATK triple coil pu
- ATK 3-band eq
- D'Addario® Strings
- Hardware color : Cosmo Black
- Scale : 864mm/34"
- Factory Tuning : 1D, 2A, 3E, 4B
- String Gauge : .050/ .070/ .090/ .110
- Color : BGW (Burgundy Wine)



Paul Gray's Signature PGB 12th fret nine-pointed star Slipknot inlay.



ARCH ENEMY
Sharlee D'Angelo
SIGNATURE
MODEL



IN FLAMES
Peter Iwers
SIGNATURE
MODEL

PIB1 BK

- 5pc PIB Maple/Bubinga neck-thru
- Maple wing body
- Medium frets
- MR-4 bridge (16.5mm string spacing)
- USA Bartolini® Custom neck pu
- USA Bartolini® Custom bridge pu
- 1-volume control w/PIB Active circuit
- D'Addario® Strings
- Hardware color : Gold
- Scale : 864mm/34"
- Factory Tuning : 1D#, 2A#, 3F, 4C, 5A#
- String Gauge : .045/ .065/ .085/ .105/ .120
- Color : BK (Black)

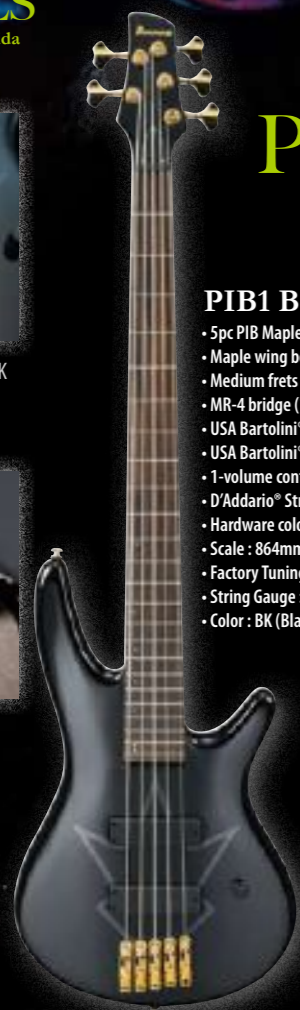

KILLSWITCH ENGAGE
Mike D'Antonio
SIGNATURE
MODEL

MDB2 BM

- 5pc MDB Maple/Walnut neck-thru
- Mahogany wing body
- Medium frets
- Accu-Cast B200 bridge (19mm string spacing)
- PFR-ALN4 neck pu
- PFR-ALB4 bridge pu
- 1-volume control w/MDB Active circuit
- D'Addario® Strings
- Hardware color : Cosmo Black
- Scale : 864mm/34"
- Factory Tuning : 1F, 2C, 3G, 4C
- String Gauge : .055/ .075/ .095/ .120
- Color : BM (Brown Mahogany)



A 5pc maple/walnut MDB thru-neck on the Mike D'Antonio Signature MDB2 bass.

SHADOWS FALL
Paul Romanko
SIGNATURE
MODEL



PRB2 BWF

- 5pc PRB Maple/Walnut neck
- Ash wing/ Ash center w/Walnut stripe body
- Medium frets
- MR-4 bridge (19mm string spacing)
- PFR-ALN4 neck pu
- PFR-ALB4 bridge pu
- 1-volume control w/PRB Active circuit
- D'Addario® strings
- Hardware color : Cosmo Black
- Scale : 864mm/34"
- Factory Tuning : 1F, 2C, 3G, 4D
- String Gauge : .050/ .070/ .085/ .105
- Color : BWF (Burgundy Wine Flat)



Paul Romanko's Signature PRB2BWF boasts a Mono-Rail IV bridge for stability and massive sustain.



Back view of the Paul Romanko Signature PRB2BWF's 5-piece Maple/Walnut PRB4 bolt-on neck.



SDB1 BKF

- 5pc SDB Maple/Bubinga neck-thru
- Mahogany wing body
- Medium frets
- MR-4 bridge (19mm string spacing)
- PFR-N4 neck pu (black pole piece)
- PFR-B4 bridge pu (black pole piece)
- EQB-II DX 2-band eq
- D'Addario® Strings
- Hardware color : Cosmo Black
- Scale : 864mm/34"
- Factory Tuning : 1D#, 2A#, 3F, 4C
- String Gauge : .060/ .080/ .100/ .120
- Color : BKF (Black Flat)



Sharlee D'Angelo's Signature SDB1 features neck-thru construction and special neck contouring for ease of playing.



Sharlee D'Angelo's fearsome SDB1BKF features a Mono-Rail IV bridge for massive stability, no matter the assault.

Jumpstart

When we say "Everything you need to get out and gig," we mean everything—amp, axe, accessories. All it takes is you and your desire to make your dreams real—to get out of the audiences and up on stage where you belong.



GRX70DX J -Jumpstart-

Features GRX electric guitar and Jumpstart Guitar Package Accessories.

Amplifier

10 watt dedicated guitar amp

Package Accessories

- Electronic Tuner
- Gig Bag
- Guitar Strap
- Picks
- Accessories Pouch



GRX70DXJ
BKN

GRX70DXJ
CA

GRX70DXJ
JB



GSR190 J -Jumpstart-

Features GSR electric bass and Jumpstart bass Package Accessories.

Amplifier

15 watt dedicated bass amp

Package Accessories

- Electronic Tuner
- Gig Bag
- Bass Guitar Strap
- Picks
- Accessories Pouch



GSR190J
TR

GSR190J
BK

GRG121EXJ -Jumpstart-

Features GRG electric guitar and Jumpstart Guitar Package Accessories.

Amplifier

15 watt dedicated guitar amp w/reverb

Package Accessories

- Electronic Tuner
- Gig Bag
- Guitar Strap
- Picks
- Accessories Pouch



GRG121EXJ
BKN



GSA6 J -Jumpstart-

Features GSA electric guitar and Jumpstart Guitar Package Accessories.

Amplifier

15 watt dedicated guitar amp w/reverb

Package Accessories

- Electronic Tuner
- Gig Bag
- Guitar Strap
- Picks
- Accessories Pouch



GSA6J
JB

GSA6J
BKN



GRGM21GB
BKN

GRGM21GB BMB

- 1pc GRGM Maple neck
- Poplar body
- Medium frets
- Fixed bridge
- Standard (H) neck pu
- Standard (H) bridge pu
- Hardware color: Chrome
- Scale: 560mm/22"
- Colors: BKN (Black Night) BMB (Beam Blue)

miKro

Small hands make big sounds with the Ibanez miKros. These compact guitars keep many of the features of their bigger counterparts and even come with a gig bag for hitting the road.

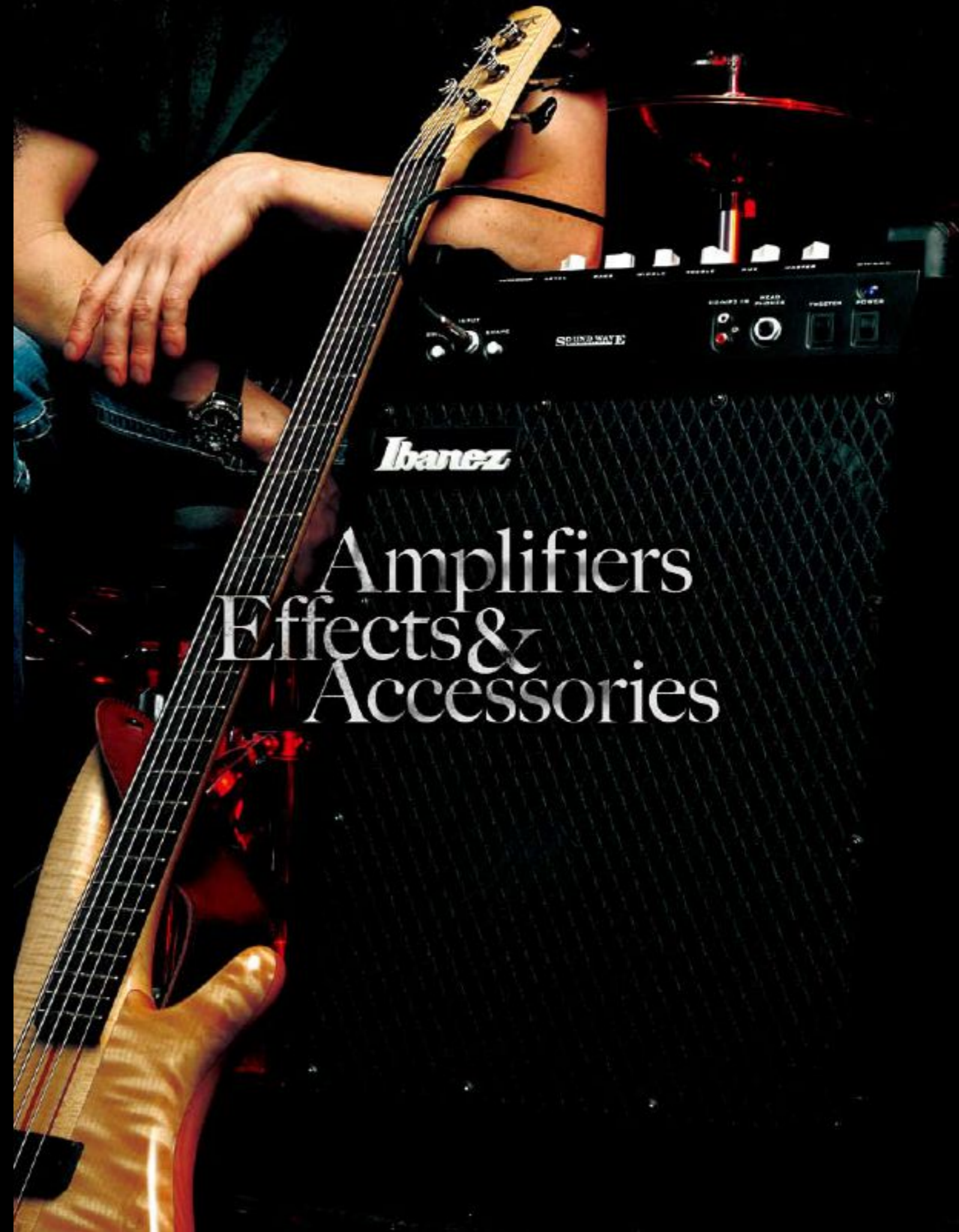



6 Band Graphic EQ

Promethean series amps feature 6-band Graphic EQ that allows you to make precise tonal adjustment in any type of environment. Each frequency is carefully selected to be the most demanded by bass players. The 6-band EQ can be bypassed by a selected switch.



Vibe Control

Control tonal character from creamy vintage sounds to modern sounds. Also, the On/Off push switch allows you to change playing character, from walking to picking and/or slapping, instantly. (On/off can be controlled by optional IFS2X footswitch.)



Aux/Phones

The included aux input allows you to play along with a connected MP3 or CD player. With headphone out, it's great for bedroom jam sessions or sound check at rehearsal.



Line Out

The balanced XLR output sends a balanced signal to the mixing console and/or main PA system in any live or studio situation. Pre- or Post EQ switchable and GND Lift switch-equipped along with switchable level control to avoid ground loops with other connected equipment.

Speak Loud And Carry A Small Amp

promethean

Ibanez Bass Amplifiers

One might never imagine that a small amp could produce big sound, but in terms of the Ibanez Promethean Bass amp series, that is not the case. The Promethean series amp is designed for busy working musicians who travel around from one venue to the next. Within its compact body, the Promethean features **CRITICAL** functions in order to deal with various situations and requirements in a live environment. It also gets **LOUD!!!** The working musician has it easy with the Promethean amp, a dependable workhorse of an amp.



Detachable Amp Head (P5110/P5210)

The P5110 and P5210 amp head can be easily detached without any tools. Due to its compact size, it's efficient to take it out anywhere you need to go.

P5110

Bass Combo Amplifier

- output power 250W@8Ω/500W@4Ω
- speaker unit 10" Ceramic Speaker, Dome Tweeter
- controls Mute Switch, Gain, Low/High Control, 6 Band Graphic EQ, Vibe Control, Master Volume
- i/o's Input, Aux Input, Phones Out, Tuner Out, Balanced Line Out (XLR), Footswitch Jack (Mute/Vibe)
- cabinet Ported Bass Reflection Cabinet/Tilt-up System
- size 326(W) x 332(D) x 360(H) (mm)
- weight 12.5kg

The P5110 delivers 250W@8Ω while using individually. Along with the P110C speaker cabinet, it delivers 500W@4Ω in total.



IFS2X

Footswitch

Latching footswitch with metal housing for use with the P500H and P5110. (The IFS2X is not included and is sold separately)

P500H

Bass Amplifier Head

- output power 250W@8Ω/500W@4Ω
- controls Mute Switch, Gain, Low/High Control, 6 Band Graphic EQ, Vibe Control, Master Volume
- i/o's Input, Aux Input, Phones Out, Tuner Out, Balanced Line Out (XLR), Footswitch Jack (Mute/Vibe)
- size 280(W) x 265(D) x 57(H) (mm)
- weight 2.9kg

P115C

Speaker Cabinet

- 300W
- 15" Neodymium Speaker
- Horn Tweeter
- SPEAKON® Combo Jack
- Ported Bass Reflection Cabinet
- 604(W) x 450(D) x 620(H) (mm)
- 24.8kg



P110C

Speaker Cabinet

- 250W
- 10" Neodymium Speaker, Dome Tweeter
- SPEAKON® Combo Jack
- Ported Bass Reflection Cabinet/Tilt-up System
- 326(W) x 325(D) x 460(H) (mm)
- 9.5kg



P410C

Speaker Cabinet

- 1000W
- 4 x 10" Neodymium Speaker
- Horn Tweeter
- SPEAKON® Combo Jack
- Ported Bass Reflection Cabinet
- 604(W) x 450(D) x 620(H) (mm)
- 34.3kg



P5210

Bass Combo Amplifier

- output power 500W@4Ω
- speaker unit 2 x 10" Ceramic Speaker, 2 x Dome Tweeter
- controls Mute Switch, Gain, Low/High Control, 6 Band Graphic EQ, Vibe Control, Master Volume
- i/o's Input, Aux Input, Phones Out, Tuner Out, Balanced Line Out (XLR), Footswitch Jack (Mute/Vibe)
- cabinet Ported Bass Reflection Cabinet
- size 332(W) x 376(D) x 711(H) (mm)
- weight 24.8kg

A bass combo amplifier with 2 x 10" speakers and 500W. It performs Perfectly in any situation regardless of the venue, from a small pub to a larger club situation. The head is detachable from cabinet, so you can carry it around and use just the head.

BGP500

Carry Bag

Bag for P500H. (The BGP500 is not included and is sold separately)



BGP511

Carry Bag

Bag for P5110. (The BGP511 is not included and is sold separately)

*SPEAKON® is a registered trademark of Neutrik AG

SOUND WAVE

The SWX Sound Wave Bass amp series is designed for today's bass players at all levels, who want serious versatility. The SWX delivers a thick, natural and balanced tone, while its perfect combination of function allows you to change the tonal character without any hassle. Playing the Sound Wave will give you what you need for the groove, the drive, the pocket and the tones - whether you need traditional thump or today's pop, slap and funk.



Shape Switch

Create the hi & low boost / mid cut sound instantly, which is one of the most desirable tones for many bass players.



HUE Control

All Sound Wave SWX series bass amplifiers feature the HUE control, which adjusts overall tonal character.



Internal Auto Compression Circuit

All Sound Wave SWX series bass amplifiers are equipped with internal auto compression circuitry, which minimizes distortion and keeps the sound clean and powerful. (SWX20 does not equip LED for Auto-Comp)

SWX35

35W Bass Amplifier

- output power 35Watts
- speaker unit 10" Coaxial 2Way Bass speaker
- controls Shape Switch, Bright Switch, Gain Level, Bass, Middle, Treble, Hue, Master Volume, Auto-comp w/LED
- i/o's Input, CD / MP3 Input, Line Out, Headphones
- cabinet Sealed Back Cabinet w/Tilt-Up System
- size 378(W) x 532(H) x 312(D) (mm)
- weight 14.2kg

SWX100

100W Bass Amplifier

- output power 100Watts
- speaker unit 15" Bass speaker with Piezo Horn Tweeter
- controls Shape Switch, Bright Switch, Gain Level, Bass, Middle, Treble, Hue, Master Volume, Tweeter Switch, Auto-comp w/LED
- i/o's Input, CD / MP3 Input, Direct Out w/Post EQ Switch & GND Lift Switch, Effects Loop, Headphones
- cabinet Sealed Back Ported Bass Reflection Cabinet w/ Caster
- size 520(W) x 682(H) x 312(D) (mm)
- weight 24.2kg



SWX65

65W Bass Amplifier

- output power 65Watts
- speaker unit 12" Bass speaker with Piezo Horn Tweeter
- controls Shape Switch, Bright Switch, Gain Level, Bass, Middle, Treble, Hue, Master Volume, Tweeter Switch, Auto-comp w/LED
- i/o's Input, CD / MP3 Input, Line Out, Effects Loop, Headphones
- cabinet Sealed Back Bass Reflection Cabinet w/Tilt-Up System
- size 422(W) x 632(H) x 312(D) (mm)
- weight 18.8kg

SWX20

20W Bass Amplifier

- output power 20Watts
- speaker unit 8" Coaxial 2Way Bass Speaker
- controls Shape Switch, Bright Switch, Gain Level, Bass, Middle, Treble, Hue, Auto-comp
- i/o's Input, CD / MP3 Input, Headphones
- cabinet Sealed Back Cabinet
- size 337(W) x 410(H) x 240(D) (mm)
- weight 8.6kg



Bright Switch

Selectable Normal and Bright modes change the sound character immediately, from the tone of passive bass to that of active bass.

TROUBADOUR

ACOUSTIC GUITAR AMPLIFIER

What's the one thing that almost all small venue musicians strive for when it comes to amplifiers? Some might say "pure immersive tone", which would undoubtedly be followed by "portability". The Ibanez T-Series Acoustic Guitar Amplifiers deliver exactly that, along with the striking appearance of a hand crafted boutique amplifier. Whether you're strumming away at the local coffee shop or playing weekly gigs at a religious venue, the sounds of the T-Series will fill the room. Plus, you won't have to break your back getting your amp in and out. The Ibanez T-Series was designed with portability in mind.



T10

10W Acoustic Guitar Amplifier

- output power 10 w
- speaker unit 6.5" Speaker
- controls Mid Shape, Hue, Chorus w/Speed Control, Internal Limiter, Volume
- i/o's Guitar Input, CD/AUX Input, Headphones/Line Out
- cabinet Closed Back Cabinet w/Tilt-up System
- size 205(W) x 258(H) x 195(D) (mm)
- weight 3.4kg

T20

20W Acoustic Guitar Amplifier

- output power 20 w
- speaker unit 8" Coaxial Speaker (with tweeter)
- controls 3 Band Eq w/Sweepable Mid, Natural Mode/Shaped Mode Switch, Chorus w/Speed Control, Reverb, Internal Limiter, Mic Channel w/Tone Control, Mic Volume, Guitar Volume, Master Volume
- i/o's Guitar Input, Microphone Input (XLR), CD/AUX Input, Headphones/Line Out
- cabinet Sealed Back Cabinet w/Tilt-up System
- size 267(W) x 318(H) x 241(D) (mm)
- weight 6.6kg

T35

35W Acoustic Guitar Amplifier

- output power 35 w
- speaker unit 10" Coaxial Speaker (with tweeter)
- controls 3 Band Eq w/Sweepable Mid, Natural Mode/Shaped Mode Switch, Chorus w/Depth & Speed Control, Reverb, Internal Limiter, Mic Channel w/Tone Control, Mic Volume, Guitar Volume, Master Volume
- i/o's Guitar Input, Microphone Input (XLR), CD/AUX Input, Headphones Out, Stereo Balanced Line Out, Foot Switch Jack (Chorus/Reverb)
- cabinet Ported Bass Reflection Cabinet w/Tilt-up System
- size 325(W) x 396(H) x 304(D) (mm)
- weight 10.5kg



Dual "MODE" Switch

The natural mode produces rich, warm acoustic sounds with shimmering overtones perfect for fingerstyle playing. The shaped mode scoops the mids, producing an open sound with a tight bottom end for strumming styles.



Chorus

All Troubadour Series Amplifiers feature chorus with soft natural mids and crystal clear highs.



Mic Input

The mic input features a totally independent mic preamp, so it won't be colored by any effects going through the guitar side. It also features independent tone and volume controls.



CD/AUX Input

The included aux input allows you to play along with a connected MP3 or CD player, great for bedroom jam sessions or rigorous woodshedding.

X Tone Blaster

The new generation Tone Blaster X series amps were designed and created to answer the needs of today's guitarist. The parametric mid EQ allows you to dial in any tone you're looking for in an instant. The exclusive X mode allows you to get monstrously heavy and lets you cut through the din of the loudest rhythm section. The gain control in the normal channel can be dialed down to give you anything from a clean jazz tone to a crunchy, slightly overdriven rock'n roll tone. Plug in and express yourself with TBX.



TBX150H 150W Guitar Amplifier

- output power 150W@4Ω
- controls Normal Channel - Overdrive Switch, Gain, Bass, Middle, Treble, Volume, Reverb Level
Hot Channel - X Mode Switch, Gain, Bass, Middle Frequency, Middle Level, Treble, Volume, Reverb Level, Channel Switch, Hue
- i/o's Input, Send, Return, 2 x Speaker Output, Footswitch 1 & 2
- cabinet W/Accessory Box
- size 636(W) x 252(D) x 259(H) (mm)
- weight 14.1kg

IS412CS Speaker Cabinet

- speaker unit 4 x 12" Ibanez IS1216G
- power handling 320Wrms/640Wmax
- i/o's 2 x Input (4Ω&16Ω)
- cabinet IS412CA : Traditional Angled
IS412CS : Straight Front Angled
- size 707(W) x 334(D) x 755(H) (mm)
- weight 34.0kg

*Also Available IS412CA w/Angled Front

TBX150R 150W Guitar Amplifier

- output power 150W@4Ω
- speaker unit 2 x 12" Ibanez IS1208G
- controls Normal Channel - Overdrive Switch, Gain, Bass, Middle, Treble, Volume, Reverb Level
Hot Channel - X Mode Switch, Gain, Bass, Middle Frequency, Middle Level, Treble, Volume, Reverb Level, Channel Switch, Hue
- i/o's Input, Send, Return, Speaker Output, Footswitch 1 & 2
- cabinet Closed Back Cabinet
- size 668(W) x 274(D) x 500(H) (mm)
- weight 24.5kg



X Mode/Channel

The X mode/channel emphasizes tighter low end and a unique tonality in the midrange, which increases sustain and harmonics.

MIMX

Traditional companies provide versatility and warm vintage tones with their modeling amps, but only Ibanez brings you the same versatility plus the heavy, searing modern tones required by today's players. The MIMX amps offer a wider variety of distortion and overdrive than any other modeling amp currently available, and there's still plenty of classic and clean tones to get you through any gig.



MIMX150H 150W Fully Digital Modeling Head

- 150 watt @ 4 ohms
- Fully digital programmable preamp with 11 amp models
10 memory locations
50 rhythm patterns
13 digital effects
- Accessory compartment
- 636(W) x 252(D) x 259(H) (mm)
- Weight : 13.9kg



IFC2 Effects Foot Controller

The PEDAL FX section is ONLY accessible using the optional Ibanez IFC2 Foot Controller for MIMX150H/MIMX65. (The IFC2 is not included and is sold separately)



IFS4X Footswitch

Latching 4-button footswitch with metal housing for use with the TBX150H/TBX150R.



IFS2X Footswitch

Latching footswitch with metal housing for use with the TBX30R, TBX65R and T35.



MIMX65 65W Fully Digital Modeling Combo

- 65 watt guitar amp
- 12" Ibanez IS1204G speaker
- Fully digital programmable preamp with 11 amp models
10 memory locations
50 rhythm patterns
13 digital effects
Chromatic Tuner
- 1/4" CD/MP3 input jack
- 1/4" headphones/record out jack
- Closed-back Cabinet design
- 491(W) x 254(D) x 451(H) (mm)
- Weight : 16.2kg



TBX65R 65W Guitar Amplifier

- output power 65W@4Ω
- speaker unit 12" Ibanez IS1204G
- controls Normal Channel - Overdrive Switch, Gain, Bass, Middle, Treble, Volume, Channel Switch
Hot Channel - X Mode Switch, Gain, Bass, Middle Frequency, Middle Level, Treble, Volume, Reverb Level
- i/o's Input, CD/MP3 In, Footswitch, Headphones
- cabinet Closed Back Cabinet
- size 491(W) x 254(D) x 451(H) (mm)
- weight 17.7kg



TBX30R 30W Guitar Amplifier

- output power 30W@8Ω
- speaker unit 10" Ibanez IS1008G
- controls Normal Channel - Gain, Volume, Channel Switch
X Channel - Gain, Volume
EQ - Bass, Middle Frequency
Middle Level, Treble, Reverb Level
- i/o's Input, CD/MP3 In, Footswitch, Headphones
- cabinet Open Back Cabinet
- size 440(W) x 222(D) x 413(H) (mm)
- weight 8.3kg



TBX15R 15W Guitar Amplifier

- output power 15W@4Ω
- speaker unit 8" Ibanez IS804
- controls Normal Channel - Gain, Volume, Channel Switch
X Channel - Gain, Volume
EQ - Bass, Middle Frequency
Middle Level, Treble, Reverb Level
- i/o's Input, CD/MP3 In, Headphones
- cabinet Closed Back Cabinet
- size 367(W) x 201(D) x 351(H) (mm)
- weight 7.3kg



IBZ10G Guitar Amplifier

- output power 10W@8Ω
- speaker unit 6.5" speaker
- controls Overdrive On/Off Switch, Gain, Bass, Middle, Treble, Volume
- cabinet Guitar Input, Headphone, CD Input
- size Closed-Back Cabinet
- weight 274(W) x 200(D) x 313(H) (mm)
- weight 5.3 kg

IBZ10G offers the famous Tone Blaster distortion sound with its affordable price. Its closed back cabinet and redesigned 6.5" Power Jam speaker produce real heavy tone. 3 band active EQ offers versatile sounds. Also it has CD input to play with music from CD or rhythm machine.



IBZ10B Bass Amplifier

- output power 10W@8Ω
- speaker unit 6.5" speaker
- controls Bass, Middle, Treble, Presence, Volume
- cabinet Bass Input, Headphone
- size Closed-Back Cabinet for "phatter" bass tone
- weight 274(W) x 205(D) x 313(H) (mm)
- weight 5.1 kg

IBZ10B is 10W amplifier designed for bass guitars. It is equipped with 3 band EQ and presence control for responding to every bass guitars. Its closed back cabinet and 6.5" Power Jam speaker give accent to primary bass sound.

IBZ



JEMINI - Steve Vai Signature Distortion "JEMINI"

- controls Distortion A / B, DRIVE, TONE, LEVEL
- switch LED BRIGHT/SAVE
- i/o's INPUT / OUTPUT
- size 140mm(D) x 170mm(W) x 58mm(H)
- power source Operates with a DC 9V AC Adapter or 9V Battery



1. LED Lit Controls
Each side includes drive, tone and level controls with LED indicators around each control and a LED bright/save control switch for daytime use or saving the battery.



2. Steve Vai Signature Foot Pedals
Steve's trademark logo is imprinted on the Jemini's foot switches.



3. Heavy Duty Aluminum Housing
The housing is finished off with Steve's infamous trademark swirl paint job.

Jemini
distortion

Steve Vai's Signature Distortion Pedal with overdrive and distortion in one package. Featuring a rigid aluminum case, magnificent LED lights around the knobs, and a unique multicolor case with Vai logo rubber foot pedals. The JEMINI's meant to be seen and heard.

TUBE KING

While the tube in many 9-volt tube-overdrive pedals merely functions like a filter, the TK999 Tube King and its crown jewel 12AX7 tube get genuine high voltage, just like a tube preamp. The result? The Tube King can make any solid-state amp sound just like a tube amp, with massive, tight overdrive/distortion.

TK999OD Tube King Overdrive

- Genuine High Voltage Tube Overdrive
- 3 band EQ with presence
- Gain and level controls
- Hi/Low input switch
- AC Adapter included



TK999HT Tube King Distortion

- Genuine High Voltage Distortion Pedal
- Actual 12AX7 Tube
- Active EQ plus Presence Switch
- VOID Control
- AC Adapter included

AIRPLANE FLANGER

The Paul Gilbert Signature AF2 AIRPLANE Flanger is two pedals in one package. One section is a traditional chorus flange (TAXI); the other is an insane (TAKEOFF) flange (hence the "AIRPLANE" moniker), which provides virtuoso guitarist Paul Gilbert's own "Crazy Flange" sound. Time to buckle up. The AF2 features Manual (delay time), Speed (modulation speed), Range (depth of modulation), and Enhance (feedback) controls.



AF2 - Paul Gilbert Signature Flanger "AIRPLANE FLANGER"

- controls TAXI : Flange/Chorus Type Modulation Effect
TAKEOFF : Jet Sound (shifting pitch up and down)
MANUAL : Delay Time, SPEED : Modulation Speed, RANGE : Depth of Modulation
ENHANCE : Feedback, EFFECT ON/OFF Switch, TAXI/TAKEOFF Switch
- i/o's INPUT/OUTPUT (Mono)
- size 180(W) x 134(D) x 65(H) (mm)
- power source Operates with a DC 9V AC Adapter



A more affordable version of our WD7 pedal, the WD7JR presents a high quality wah-wah pedal at a great price. Activates with minimal pedal pressure. Auto Off Delay control allows you to delay the end of wah-wah effect after your foot leaves the pedal, for smooth transition and phrasing. Features a maintenance-free optical sensor - no need to worry about producing unwanted noise from the volume pot. Also includes Level control for volume adjustment.

WH10V2
Classic Wah Pedal



- Range switch : Guitar 350Hz - 2.2kHz
Bass 175Hz - 1.1kHz
- Depth control : +6 - +12dB

WH10V2

The upgrade you will notice is the die-cast metal construction, replacing the original plastic case. Feel free to dance on this sucker now—it can take anything you dish out. The WH10V2 features the same multiple feedback opamp circuit as the original, a feature rarely found in today's wah pedals. It also has a depth knob to control to level of the wah effect and a dry out for mixing a dry signal with the wah sound. The WH10V2 has a unique tone character setting it apart from all traditional wah pedals, as well as some modern tweaks so your sound keeps changing with the times.

WD7JR
Weeping Demon Junior



WD7
Weeping Demon

The Ibanez WD7 Weeping Demon Wah Pedal will have your audience screaming for more with its shrieks, cries, wails, and seductive siren songs. Among its features are spring and normal footboard action, selectable wah range, and fine tuning controls.



WD7JR/Auto-Off Delay

Adjusts the time delay from when the pedal is returned until the effect switches off. Turning this clockwise will increase the time delay, preventing the effect from turning off while you are operating the pedal. Turning this counterclockwise will make the effect turn off more quickly, so that it will turn off immediately when you return the pedal.

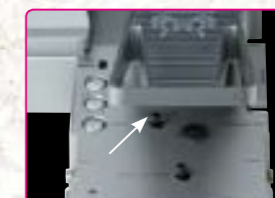

WD7/Auto-Off Delay

In the AUTO SWITCH mode, you can set the effect-off either on standard instant off when the pedal is returned to the full upright position or a delayed-off by turning the control clockwise.

CLASSICS

Sometimes it's best to keep it simple. Which is why, in a world of dizzying often over-complex technology, the durable, dependable and simple stompbox continues to be the most widely used and effective means to expand, color, distort, mutate, sustain and twist tone.



TS808HW Hand-Wired Tubescreamer

The Ibanez Tubescreamer, in its many versions and forms, can be found on pedal boards in every corner of the globe, on arena stages and in small studios and bedrooms. Its warm overdrive is a sound many players, from advanced to beginner, could never do without. Now, it gets even better with the release of the TS808HW, a Hand-Wired deluxe Tubescreamer built with the pro musician in mind.

Encased in a special, heavy duty metal box, the TS808HW is Hand-Wired with select JRC4558D chips (same as the revered and often imitated TS808) and uses Japanese high-end MOGAMI OEC cable (AWG21). Equipped with True Bypass, this Tubescreamer sends pure guitar excitement to your amplifier with no tonal loss whatsoever. This is, by far, the most evolved Tubescreamer ever created.

TS808 The Original Tubescreamer

Modeling and boutique pedal makers have copied the smooth and full tone of this pedal countless times. Now you can have Ibanez's faithful reissue at a price that doesn't break the bank. The reissue features the same JRC4558D IC chip and analog circuitry as the original. Controls include overdrive, level, and tone controls.



FL9 Flanger

Same circuitry and coveted flanging effects of the original '80s unit but constructed to closer tolerances for more consistency from unit to unit. If you've been hunting for an original but couldn't find one, or couldn't afford a high asking price, now's your chance to bag this '80s favorite. Might even be better than the original.



AD9 Analog Delay

The Ibanez AD9 Analog Delay Effect Pedal uses a compander with pre- and de-emphasis for an exceptionally clean delay. Time and level controls allow mixing between dry and delayed signals. Repeat control lets you adjust the number of repeats without runaway. 2 outputs enable dry and delayed signals to be routed separately.



TS9 Tubescreamer

The Ibanez TS9 Tubescreamer is a reissue that's just like the original in so many ways. Same factory, same components, same housing, same famous seasick-green paint, and the same cranking overdrive that made the original one of the all-time classic pedals. Guitar Player called it the best. Plug it in. Crank it up. You'll hear what all the fuss is about. Tone, drive, and level controls.



TS9DX Turbo Tubescreamer

The Ibanez TS9DX Turbo Tubescreamer Effects Pedal features the same circuit as a TS9 Tubescreamer and also offers 3 new settings for increased low end crunch: +, Hot, and Turbo.



CS9 Stereo Chorus

When it comes to compact effects, nine is the magic number. By popular demand (and the understandably escalating prices of the originals), Ibanez has reissued its popular CS9 chorus featuring the original circuitry. If you missed out on getting one of these classics the first time around, now is your chance.



DC3&DC5

Splitter cords for powering 3 or 5 pedals from one adapter.



AC109

Standard 9-volt 200mA regulated adapter for Ibanez compact effects.

TONE-LOK

EFFECTS PEDALS

On the outside, Tone-Lok effects are equipped with our exclusive "set and forget" Push-Lok rotary pots. Push the knobs down and your tone settings lock securely inside the case. No more lost settings or knobs broken. On the inside, Tone-Lok pedals feature hi-fidelity components carefully tweaked with the constant input from a new generation of Ibanez players. And all this great stuff comes encased in cool looking, road-tough metal boxes at prices the working player can afford.



AP7 Analog Phaser **TC7** TRI-Mode Chorus **SM7** Smash Box **SH7** 7th Heaven

The addition of the AP7 to the Tone-Lok series has brought with it the warm midrange sounds of a true Analog Phaser. The pedal features speed, depth, and feedback controls as well as a 3-way switchable phase circuit. When switched to 4-stage phasing, the pedal recreates the sounds of a vintage phaser. When switched to 8-stage phasing, the pedal produces more aggressive and deep phasing characteristic of modern pedals. This setting works best on more distorted lead sounds.

Are you bored with normal chorus pedals? If so, the Ibanez TC7 will bring the thrill back. The TC7 can create three types of chorus with the combination of two individual chorus circuits. It truly expands your guitar's expressiveness.

The Smash Box is the most aggressive weapon in the Tone-Lok distortion arsenal. Armed with obscene amounts of gain, tight low end, and searing highs, the Smash Box is the heavy rock sound for the contemporary guitarist. Special "VOID" noise gate and "EDGE" (sharp/smooth) controls let you handle anything from all-out shred to machine-gun metal riffs and rhythms.

Designed specifically for 7-string guitars with the input from some of Ibanez's hottest 7-string players, the SH7 7th Heaven distortion pedal accentuates the low-end girth of the 7-string while reducing unwanted string noise. A special mode switch allows you to choose between two different distortion voicings while Lo, Hi, Drive, and Level knobs give you total tone control. An absolute must-have effect for replicating the best 7-string sounds of others or creating your own individual tones.



DS7 Distortion **TS7** Tubescreamer **FZ7** Fuzz **DE7** Delay/Echo **PH7** Phaser

The most versatile Ibanez distortion pedal ever, capable of producing a wide range of smooth, dynamic overdrive tones. From a subtle tonal nudge to wallowing rock'n'roll crunch, the DS7 delivers days of sustain and gobs of gain.

The Tubescreamer isn't just a stompbox, it's an institution. Our latest generation Tubescreamer, the TS7, is no exception. With the Tubescreamer's classic subtle-but-smooth overdrive, the TS7 expands the expressiveness of your guitar while maintaining its tonal integrity. Tone adjustments are provided by the classic three knob configuration with an added "hot" switch for an extra gain boost.

Far out! A complete 60's flashback with none of the drawbacks, the FZ7 is the ultimate in psychedelic fuzz. With the FZ7's tone, drive, and level controls, it's never been easier to get the right retro tones. You can even engage the DAMAGE switch for that ratty, broken speaker sound. Yeah, baby, yeah!! Dial in, tune up, drop down or whatever turns you on.

Add new dimensions to your sound with the DE7 Delay/Echo pedal. Get the best of both worlds: high tech digital sounds comparable to expensive rack units or warm vintage tape echo sounds—all with a simple flick of the switch. TIME, REPEAT and LEVEL controls help you dial in just the right amount of delay, while stereo outputs can be used for a more spacious sound. With a range of 30ms to 2.6 seconds, the DE7 is the only sound solution for every playing situation.

Designed to emulate the effect of a rotating speaker, the PH7 has a switchable phase circuit capable of either four or eight stages of smooth phasing. With these two very different tonal modes, you can go from a subtle shimmer to all out 70's "Let's Get Funky" phasing.



PM7 Phase Modulator **AW7** Autowah **LF7** Lo Fi **PD7** Phat-Hed Bass Overdrive **SB7** Synthesizer Bass

If you've gone through one phase after another, maybe it's time for the final phase. The PM7 Phase Modulator offers three types of waveforms to give you everything from classic phaser to DJ effects to toy ray gun sounds. Since good things come in threes, the PM7 also has three phase stages: vintage, deep and dry, and deep and pronounced. With some minor tweaking, the PM7 goes from traditional to 21st century and beyond.

There are autowahs. And there are autowahs. But the Tone-Lok AW7 isn't just any autowah. It's got standard wah where both the highs and lows are cut and it's got a wah setting where only the highs are cut. And it's got distortion. Band Pass Filter provides the sound of a standard wah pedal left at one setting (a favorite wah pedal technique of Joe Satriani). You can even change the chain order of the effects to get different tones: either distortion to wah or wah to distortion.

The first dedicated filter pedal for the guitar, the LF7's voltage controlled analog high and low pass filters allow you to emulate transistor radio and megaphone type sounds. Best used at the end of a signal chain in combination with other pedals, this ticking time bomb creates wide soundscapes of far out tones that previously required a massive rack of analog electronics. The Lo Fi also performs equally well with vocals, drum machines or in any "mix-down" context.

Why let guitarists rule the stage? Loaded with growing low-end distortion, the PD7 levels the playing field for the rock bassist. The PD7 is armed with three pre-amp style voicings and an attack control switch, which accents the amount of harmonic content in your sound. With DRIVE, LO, HI, and LEVEL knobs, dialing in a thunderous bass sound has never been easier.

If you're looking for new tones or you're still smoldering with resentment against synth bass keyboard players, the SB7 is the ticket. You've got real time feel—in other words no annoying tracking errors and delays. You can even play chords.

DESKTOP AMPS

Into jamming at your desk? Though impossibly small with its 3" speaker, the sound level on our desktop amp packs more than enough punch at 1.6 watts. Adjust the EQs (Treble and Contour) to your liking, or flip the Hot Switch for heavy distortion for electric guitar (Model DAG1) or a mid-boost jump for electric bass (Model DAB1). And by plugging into both the headphone output and AUX input, you can jam along with music from your portable disk player or computer! Both models are powered by either a 9V battery or the included 12V AC adapter.



DAG1 Desktop Guitar Amplifier

- output power 1.6W @ 8Ω
- speaker unit 3" speaker
- controls Distortion On/Off Switch, Treble, Contour, Volume
- i/o's Guitar Input, Headphone, CD Input
- size 102(W)x116(H)x63(D) (mm)
- power source 9V battery (sold separately)
12V AC Adapter included

DAB1 Desktop Bass Amplifier

- output power 1.6W @ 8Ω
- speaker unit 3" speaker
- controls Mid-Boost On/Off Switch, Treble, Contour, Volume
- i/o's Bass Input, Headphone, CD Input
- size 102(W)x116(H)x63(D) (mm)
- power source 9V battery (sold separately)
12V AC Adapter included

TUNERS

When you make 6-string, 7-string and 8-string guitars for players who use all kinds of alternate tunings, you'd better be very serious about tuning. We are. Our wide variety of compact tuners offer strict accuracy, easy operation and our famous Ibanez reliability.

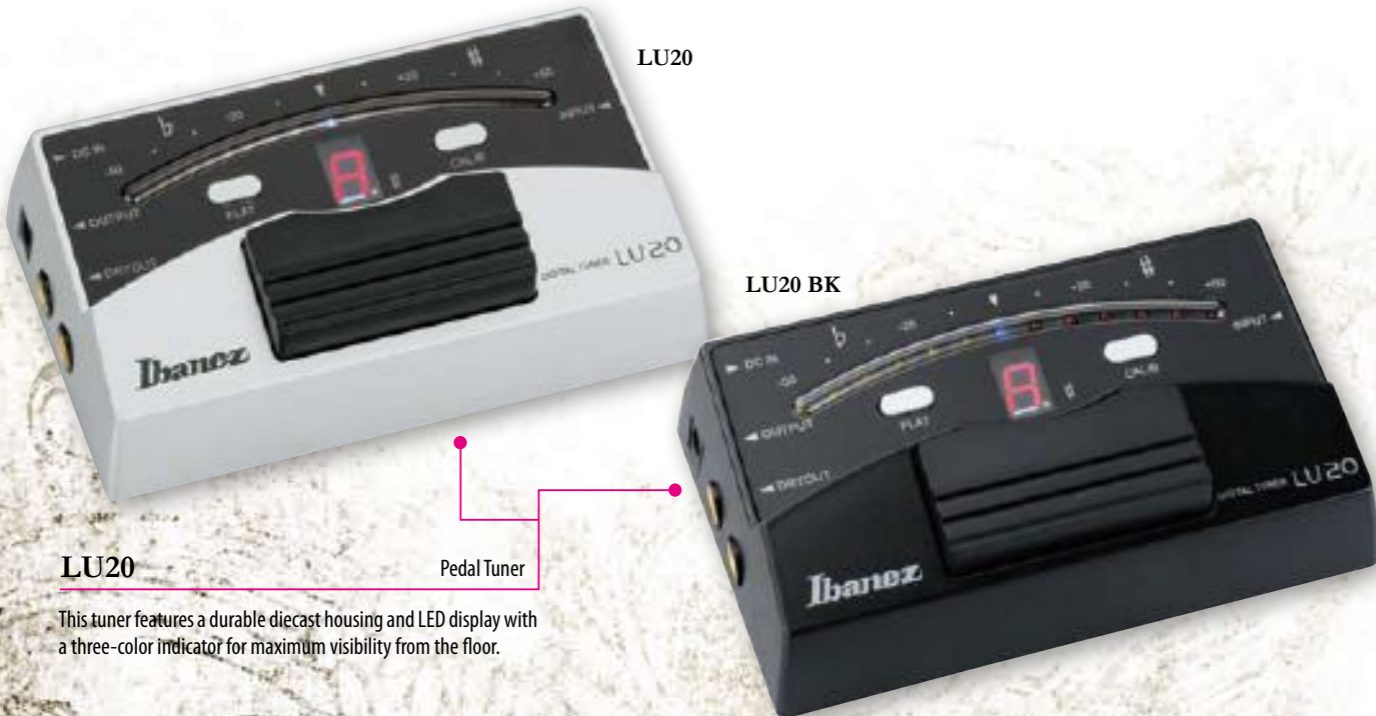

LU20

LU20 BK

LU20

Pedal Tuner

This tuner features a durable diecast housing and LED display with a three-color indicator for maximum visibility from the floor.

Clip Tuner

Both Ibanez clip tuners, PU20 and PU10, are designed to tune electric and acoustic guitars, basses, violins, banjos, mandolins, and more without interference from ambient room noise. It does it all without the use of wires, microphones or pickups. Tuning in noisy environments is a snap because the unique, flexible clamp actually feels the instrument's vibration instead of relying on sound. PU20 features backlit large LCD display for maximum visibility even in the dark stage. PU10 features the 4 hinges that allow a perfect view of the tuner's LED display from nearly any angle.

* Black and Silver colors are available in PU10.



PU20

PU10 SL

PU10



RU10

RU10 WH

RU10 RD

RU10

Jam Tuner

There is no doubt that tuning is important. However it is just preparation, when your goal is to be playing guitar and having fun. With the Ibanez RU10, Jam Tuner, you can do both without firing up your amp. Besides functioning as a chromatic tuner, the RU10 combines a metronome and the Rhythm Play function that features preset rhythm patterns to play along with. The gain control enables you to produce an amazing, real deal distortion sound out of the built-in speaker, letting you jam right away.



LU10

Chromatic Tuner

This tuner is designed for electric guitars and basses, as well as acoustic guitars. The clever LU10 is an easy-to-use tuner with an LED display including a large, bright note display. It's very easy to work with.



GU1

GU1 SL

GU1

Automatic Tuner

The GU1 is the first guitar / bass auto tuner with strobe displaying mode. In needle displaying mode, the meter moves the same as the tuner ever. In strobe displaying mode, the meter goes round and tune. The operation is very simple even for beginners.



GU40 BL

GU40 RD

GU40 SL

GU40

Automatic Tuner

The colorful GU40 guitar tuner from Ibanez features hands-free tuning. This no hassles auto tuner is fast and accurate and works with guitar, bass or almost anything that shares the same tuning. It even has seven tuning notes for 7-string guitars. The GU40 guitar tuner has a built-in mic for fast and accurate metering.



CU40

Chromatic Tuner

The CU40 chromatic guitar tuner from Ibanez is fast and accurate and works with guitar, bass or almost anything else. The CU40 has a large LCD display, LED 'flat' and 'sharp' guide lights and a built-in mic for fast and accurate metering.



MU40

Metronome Tuner

The dual purpose Ibanez MU40 Tuner/Metronome indicates pitch with both an LCD needle display plus red flat and sharp LEDs plus a green in-tune LED. Designed for electric guitars, basses and acoustic instruments. Built-in metronome with speaker, mute switch, and headphone input. Ideal for teachers and students.

CABLES

Series PSC

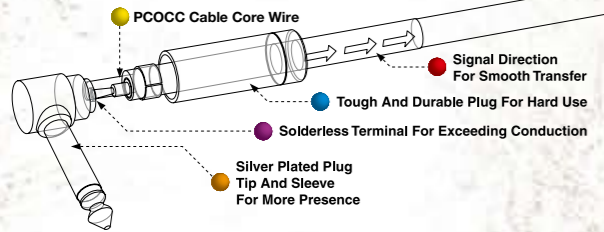

PCOCC stands for "Perfect Crystal by Ohno Continuous Casting Process". This material has remarkable lower resistance and transfers far more High-Frequency signal than TPC or OFC cables. The clear and precise sound PSC cables provide are perfect for any musician.

PSC10	
PSC20	
PSC05LL	Patch Cable
PSC08LL	Patch Cable



Series 96

NSC6	
NSC6L	
NSC10	
NSC10L	
NSC15	
NSC15L	
NSC20	
NSC20L	
NSC05LL	Patch Cable
NSC08LL	Patch Cable
NSC10BK	Woven
NSC20BK	Woven

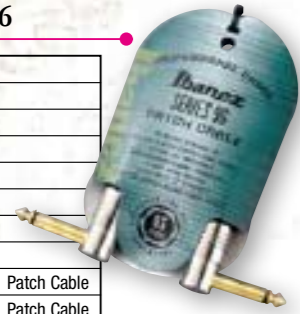

96 micro-standards of silver plated copper core wires offer low impedance and maximum signal transfer.
 • Core: 0.1 x 96 (Silver Plated)
 • Shield (Braided): 0.1 x 8 x 12 (OFC 99.99%)
 • Sure Grip Rubber on Plug
 • Velcro Strap with Ibanez Logo equipped
 • Outer Jacket: PVC, Woven

Series DS

DSC6	
DSC6L	
DSC10	
DSC10L	
DSC10LL	
DSC15	
DSC15L	
DSC15LL	
DSC20	
DSC20L	
DSC20LL	
DSC25	
DSC25L	
DSC05LL	Patch Cable
DSC08LL	Patch Cable
DSC10BK	Woven
DSC10BL	Woven
DSC10RD	Woven
DSC20BK	Woven
DSC20BL	Woven
DSC20RD	Woven



Double-shielded construction offers pro-quality and durability at standard cable prices.
 • Core: OFC (99.99%)
 • Shield: OFC (99.99%) Braided and Aluminum Sheet
 • Velcro Strap with Ibanez Logo equipped
 • Outer Jacket: PVC, Woven (Black, Red & Blue colors are available)

Series STC

STC6	
STC10	
STC10L	
STC15	
STC15L	
STC20	
STC20L	
STC25	
STC25L	
STC05LL	Patch Cable
STC08LL	Patch Cable



Model Number System

Series
PSC : Series PSC
NSC : Series 96
DSC : Series DS
STC : Series STC

N S C 0 8 L L

Length

6	6ft/1.83m	25	25ft/7.63m
10	10ft/3.05m	50	50ft/15.24m
15	15ft/4.58m	05	0.5ft/15cm
20	20ft/6.10m	08	0.8ft/25cm

Plug Type

L : Straight - Right Angle
LL : Right Angle - Right Angle
none : Straight - Straight

Speaker Cables

• Core: 0.1 x 200 (Silver Plated) x 2
 • Shield: Braided
 • Velcro Strap with Ibanez Logo equipped
 • Plug Type: 1/4" Neutrik® Speakon
 • Length: 1.83m (6ft), 3.05m (10ft), 7.63m (25ft), 15.24m (50ft)



Plug Type	Plug Type		
1/4" - 1/4"	NL4FX - NL4FX		
Model#	Length	Model#	Length
SPCPP6	6ft/1.83m	SPCNN6	6ft/1.83m
SPCPP10	10ft/3.05m	SPCNN10	10ft/3.05m
SPCPP25	25ft/7.63m	SPCNN25	25ft/7.63m
SPCPP50	50ft/15.24m	SPCNN50	50ft/15.24m

Microphone Cables

• Core: OFC (99.99%)
 • Shield (Braided): 0.12 x 64
 • Velcro Strap with Ibanez Logo equipped
 • Plug Type: 1/4", XLR
 • Length: 3.05m (10ft), 6.10m (20ft), 15.24m (50ft)



Plug Type	Plug Type		
XLR-1/4"	XLR-XLR		
Model#	Length	Model#	Length
MCCP10	10ft/3.05m	MCCC10	10ft/3.05m
MCCP20	20ft/6.10m	MCCC20	20ft/6.10m
MCCP50	50ft/15.24m	MCCC50	50ft/15.24m

STRAPS



GS260

Trapper Strap

60mm width / 1500mm length

Simply slide Trapper Strap ends over the guitar's strap button so the button is lodged tight, just above the Ibanez logo.

GS260 BK

GS260 WH

GS260 RD



GS360 BK

Quick Adjust

60mm width / 1500mm length

The Grip Adjuster enables you to find your most comfortable position with one simple operation. By pressing the lever, the Grip Adjuster slides and changes strap length. Sliding the Grip Adjuster down while holding the lever makes the belt shorter and moves the guitar up, while sliding the Grip Adjuster up, will give you the opposite effect.



LS65TL BRE

LS65TL BKE

LS65TL BRS

LS65TL BKS

LS65TL BKG

LS65TL WHG



GS60 WR

GS60 MG

GS60 DB

GS60 KI

GS60 BK

GS60

60mm width / 1500mm length

GS60L

60mm width / 1800mm length

LS65 Leather Strap

1400mm length



GS60LG BK

GS60LG SL

GS60TA BK

GS60TA WH

GS60TA RD

GS60ST GY

GS60ST RD

GS60TL GR

GS60TL ML

GS60TL PK

GS60CI SL

GS60CI BR

BAGS

Standard Bags

Newly upgraded standard bags from Ibanez. Improved strap angle, thick shoulder pad and waist belt all combine to make your gear feel lighter than ever.

ISGB501-BK	Bag for El. guitar
ISBB501-BK	Bag for El. bass

Original Bag/IGB611-BBK

Black shoelace design, classy and tough looking. Thick cushioning safely protects your gear.

Double Bags

Ibanez double gig bag lets you carry two instruments in one bag. With the wheel on the bottom, you can carry your guitars without any hassle.

IDGB5-BK	Bag for El. guitar
IDBB5-BK	Bag for El. bass

IDGB5-BK

IDBB5-BK

Deluxe Gig Bags

Sometimes you want something new and different in your gear, even with your gig bag. The IGB601/BB601 deliver, with loads of pockets (8!!!) to carry what you need – tuner, cables, sheet music, portable players etc. And with the ergonomic-fit strap angle, your traveling load just might feel lighter than ever.

IGB601	Bag for El. guitar
IBB601	Bag for El. bass

ISGB531-CCT
Camouflage City

ISGB531-CSD
Camouflage Sand

Camouflage Color Bags

Camouflage color versions of standard bag (ISGB501) for El. guitar.

ISGB531-CGR
Camouflage Green

ISGE501-BKO

ISGE501-BKS

Ultra-Deluxe Bags

Ultimate gig bag for players on the go. The IGB701/BB701 securely protects your instruments with extra pads from the body to the neck and with the bottom cover. These bags come with water-resistant exteriors and extra-padded backpack straps.

IGB701-BK	Bag for El. guitar
IBB701-BK	Bag for El. bass

Enamel Bags

This gig bag can not only protect your guitar, but it can also make a fashion statement. The colored bags are made of glossy black enamel in two color options of orange or silver Ibanez logo to fit your own personal style. (only for El. guitar)

GBP

Deluxe Bags w/Backpack

The GBP/BBP bags feature a detachable backpack. Not only is it handy for carrying accessories around along with your guitar or bass, it detaches for typical backpack use.

GBP	Bag for El. guitar
BBP	Bag for El. bass

Backpack

BBP

CASES

No matter which Ibanez guitars or basses you choose, you'll want to protect your precious instrument. Do it in style with an authentic Ibanez hard shell case.



Molded Cases

M5C	for RG, RG7, S (except 27" scale & left handed models)
MB5C	for SR (except left handed models)

Detachable Cushion (for regular guitar)

Detachable Cushion (for thin body)



Molded Cases

M100C	for RG, RGD, RG7, S, SA (except 27" scale & left handed models)
MB100C	for SR, SRX, EDB (except left handed models)



Wood Cases

W50RG	for RG, RGD, RG7, RG8, S, SA (incl. 27" scale & left handed models)
W50DNT	for DN
W50BTB	for BTB, ATK, JTKB
W50SR	for all of SR (incl. left handed models)



Wood Cases

AS-C	for AS
GB-C	for AG, AGS
AR-C	for GAX, AR, ART, ARX
AFS-C	for AFS
AF-C	for AF, AK
AM-C	for AMF

STANDS

ST201

Folding guitar stand for Electric/Acoustic Guitar and Bass.



ST101

Compact size folding guitar stand for Electric/Acoustic Guitar and Bass.



ST301

Tubular guitar stand with folding tripod for Electric/Acoustic Guitar and Bass.



PICK HOLDER



PHI01 Removable, Reusable and Reliable Guitar Pick Holder

The Pick Holder can hold your picks tightly, and easily removed. The Pick Holder is a detachable sticker to be installed on your guitars and basses. The Pick Holder is reusable. If it seems to lose its adhesion, gently wash with water, reapply, and it will be as good as new!



PICKS

Ibanez picks feature traditional styles, artist signature models and special non-slip "Grip Wizard" picks.

Basic Color Series

Ibanez covers the basic picks with orthodox shape color. You can choose from 6 kinds of shapes.



Ibanez Classic Design Series

Three of Ibanez' legendary icons are now featured on picks – "Flying Finger", "Tree of Life" and a new design derived the "Ibanez checkmark".



Grip Wizard Series Rubber Grip

Non-slip rubber softly fits your finger. Available on polyacetal, or super hard PPS material picks.



Grip Wizard Series Sand Grip

Dense and wide surface sand provides hard and sure grip.



BASIC COLOR SERIES

Shape	Material	Thickness (mm)	Model No.	Available color	
4	Celluloid	Heavy	1.0	CE4H	BK/PL/SH/WH
4	Celluloid	Medium	0.75	CE4M	BK/PL/SH/WH
4	Celluloid	Thin	0.5	CE4T	BK/PL/SH/WH
6	Celluloid	Heavy	1.0	CE6H	BK/SH/WH
6	Celluloid	Medium	0.75	CE6M	BK/SH/WH
14	Celluloid	Heavy	1.0	CE14H	BK/SH/WH
14	Celluloid	Medium	0.75	CE14M	BK/SH/WH
16	Celluloid	Heavy	1.0	CE16H	BK/SH/WH/HGG/HSC/HTN
16	Celluloid	Medium	0.75	CE16M	BK/SH/WH/HGG/HSC/HTN
20	Celluloid	Heavy	1.0	CE20H	BK/SH
20	Celluloid	Medium	0.75	CE20M	BK/SH
Thumb Pick	Celluloid			CE22L	PL

IBANEZ CLASSIC DESIGN SERIES

Shape	Material	Thickness (mm)	Model No.	Available color	
16	Celluloid/*PVC	Heavy	1.0	TL16H	BK/BL/*RD/WH/GR/CL
16	Celluloid	Medium	0.75	TL16M	BK/BL/OR/WH/GR/CL
16	Celluloid/*PVC	Heavy	1.0	CI16H	BK/BL/*RD/WH/GR/CL
16	Celluloid	Medium	0.75	CI16M	BK/BL/OR/WH/GR/CL
16	Celluloid/*PVC	Heavy	1.0	IB16H	BK/BL/*RD/WH/GR/CL
16	Celluloid	Medium	0.75	IB16M	BK/BL/OR/WH/GR/CL

GRIP WIZARD SERIES

Shape	Material	Thickness (mm)	Model No.	Available color	
16	Polyacetal w/Rubber Grip	Extra Heavy	1.2	PA16XR	BK/BL/RD/WH
16	Polyacetal w/Rubber Grip	Heavy	1.0	PA16HR	BK/BL/RD/WH
16	Polyacetal w/Rubber Grip	Medium	0.8	PA16MR	BK/BL/RD/WH
16	Polyacetal w/Sand Grip	Extra Heavy	1.2	PA16XS	BK/BL/RD/WH
16	Polyacetal w/Sand Grip	Heavy	1.0	PA16HS	BK/BL/RD/WH
16	Polyacetal w/Sand Grip	Medium	0.8	PA16MS	BK/BL/RD/WH
8	PPS w/Rubber Grip	Heavy	1.0	PS8HR	BK
8	PPS w/Rubber Grip	Medium	0.8	PS8MR	BK
17	PPS w/Rubber Grip	Heavy	1.0	PS17HR	BK
17	PPS w/Rubber Grip	Medium	0.8	PS17MR	BK
30	PPS w/Rubber Grip	Extra Heavy	1.2	PS30XR	BK
30	PPS w/Rubber Grip	Heavy	1.0	PS30HR	BK

Signature Models Steve Vai

Here are the Vai's signature picks, and he won't use anything else.



1000SVWHR 1.0mm thickness featuring "rubber grip"
 1000SVMP 1.0mm thickness
 1000SVBR 1.0mm thickness
 1000SVGR 1.0mm thickness

The Offspring

Be different. The Offspring picks feature the band symbol on one side, and the band name written in Japanese on the other.



Paul Gilbert

This original shaped picks are what THE guitarist with style and speed need.



1000PGPW 1.0mm thickness
 1000PGCA 1.0mm thickness
 1000PGJB 1.0mm thickness
 1000PGWH 1.0mm thickness
 1000PGBK 1.0mm thickness

Actual Size



4



6



8



14



16



17

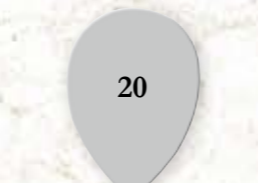

20



30

 Ben Orum All Shall Perish	 Jack Owen Deicide	 OX LORDI	 Matt Pantelis Veil Of Maya	 Pat Pattison Straight Line Stitch
 Joe Pitter Evans Blue	 Emil Pohjalainen Amberian Dawn	 Matthew Pugh The Eyes Of A Traitor	 Markus Resi myGRAIN	 Christophe RIME
 Yannick Robert	 Igor Romanov Alisa	 Patrick Rondat Patrick Rondat, Elegy	 Tim Roth Into Eternity	 Raul Ruutu Sunrise Avenue
 Henrik Sandelin Avatar	 Henri Sattler God Dethroned	 Oliver Schmidt Letzte Instanz	 Caleb Schneider Bad Acid Trip	 Roni Seppänen Tracedawn
 Waldemar Sorycha Enemy of the Sun, ReVamp	 Chris Stalder X Age, Jodyacs	 Frank Stumvoll Kryteria	 Seth Thacker Straight Line Stitch	 Gunnar H. Thomsen Tyr
 Remko Tielemans Textures	 Olli Tukiainen Poets of the Fall	 Sébastien Tuvi The Order of Apollyon, Asooth	 Patrick Uterwijk Pestilence	 Ludovico Vagnone
 Elias Viljanen Sonata Arctica	 Paul Waudby The Eyes Of A Traitor	 Marcus Wesslén Dead by April	 Jason White Straight Line Stitch	 Mick Whitney 36 Crazyfists
 Steve Whitworth The Eyes Of A Traitor	 Jussi Wickström Turisas	 Stefano "Sebo" Xotta UTEZ, Strings 24	 Mark Young (hed) planet earth	 Henke Zinger God Dethroned

Edge-Zero Tremolo



The Edge-Zero has a sharp knife-edge for extremely accurate tremolo playing. This tremolo also uses Ibanez innovations to keep string action constant and the bridge surface smooth. The specially designed arm socket prevents unnecessary wobble from the arm while providing full control over the arm's torque.

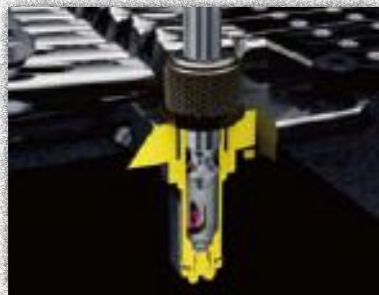

ZR-2 Tremolo



The ZR-2 is a revolutionary tremolo system. It plays incredibly smooth through the use of its ball bearing mechanism. This also keeps the string action constant, even during the most rigorous tremolo use. The top side features a smooth finish for total hand comfort, and the tremolo arm snaps in for quick setup.

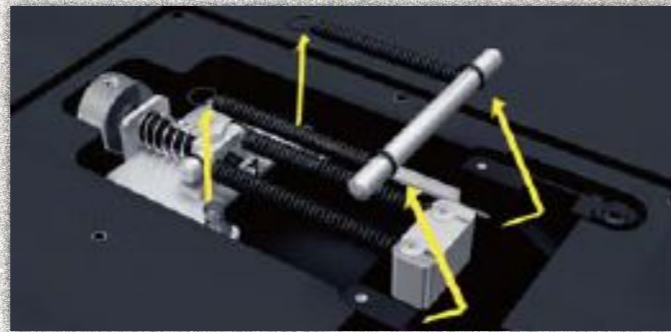
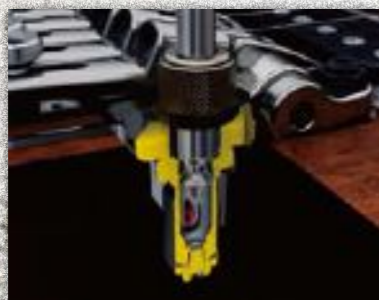

ZPS3 Zero Point System

The ZPS3 is the next stage of zero point systems. Made of lightweight Duralumin, the addition of two outer springs makes the guitar easier to tune and provides much greater tuning stability. In fact, the other strings will stay in tune even if you break a string. If you prefer a full floating tremolo setup, simply remove the stop bar.



Spring Mute

Some might think it's inevitable for tremolo springs to resonate, but that's not the case with the Ibanez Prestige. The spring-muting rubber eliminates noise from the spring, providing only clean and cutting sound.

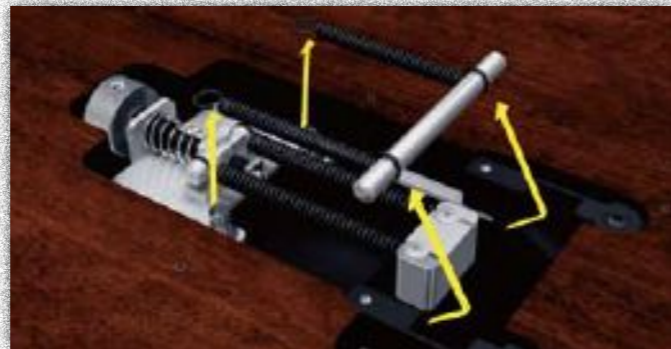

ZPS3 Zero Point System

The ZPS3 is the next stage of zero point systems. Made of lightweight Duralumin, the addition of two outer springs makes the guitar easier to tune and provides much greater tuning stability. In fact, the other strings will stay in tune even if you break a string. If you prefer a full floating tremolo setup, simply remove the stop bar.



SynchroniZR Tremolo



The SynchroniZR provides all the innovations of the ZR tremolo in a non-locking design. The one-piece saddle construction minimizes unnecessary wobble and loss of string vibration, and the ultra-light Duralumin tremolo arm keeps the bridge stable while playing. The same intonation and adjustment features of the ZR-2 make this a top-notch choice for any kind of player.



ZPS-FX System

The ZPS-FX is the simplified alternative to the ZPS3 system. This spring system allows switching from floating to non-floating tremolos with the turn of a knob on the back. Coupled with the SynchroniZR, the ZPS-FX offers total sonic control and the pinnacle of tuning stability.



Tight-Tune Bridge/Tailpiece



Solid as a rock, the Tight-Tune bridge and tailpiece were designed to lock down securely and prevent any kind of wobble or movement. Each saddle is locked into the base plate, and the bridge is anchored by stud bolts into the body of the guitar. Furthermore, the studs are also locked onto the base plate so that the maximum vibration from the string is transferred to the body.

Tight-End Bridge

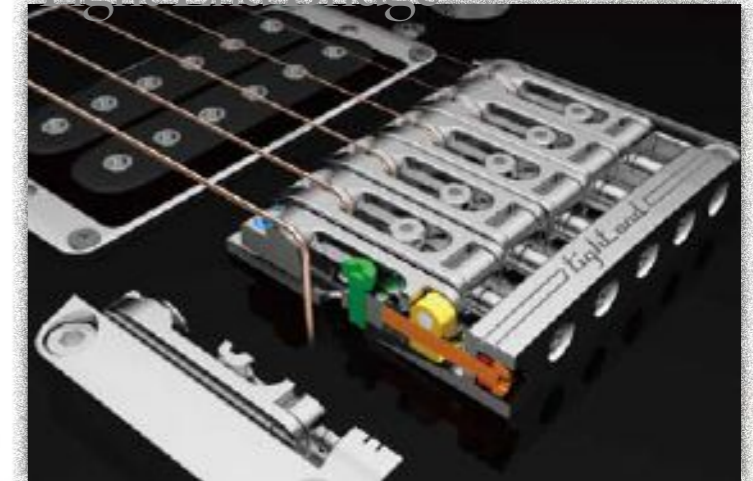

The Tight-End bridge integrates every aspect of the bridge design in rigidity and accuracy. Saddles are firmly locked onto the base plate for maximum string vibration, and remain perfectly linear during intonation adjustment for the most accurate set up. The saddle height can be adjusted individually by one screw. Also, the top side of the bridge is smooth finished. So if you play hard, the Tight-End bridge will forgive you and your hands.

MR4 Mono-Rail Bridge



The Mono-Rail Bridge is the ultimate in string isolation for bass. Each saddle is independently and securely locked down to the body for maximum vibration transfer and no interference. One screw controls the height of each saddle for easy adjustment.

Pickup Specifications

MODEL NO.	NAME	RECOMM. POSITION	CONSTRUCTION	MAGNET	DESCRIPTION KEY
					RECOMMENDED POSITION B : BRIDGE, M : MIDDLE, N : NECK CONSTRUCTION H : HUMBUCKING, S : SINGLE COIL BASS ONLY/A : ACTIVE, P : PASSIVE MAGNET AL : ALNICO, C : CERAMIC
IBANEZ GUITAR PICKUPS					
ACH-BL	ACH-BL	B	H	C	Single coil sized blade humbucking pickup. Sound in-between humbucking and single coil.
ACH1	ARTCORE 1	N	H	C	Clean sounding with a slight overdrive.
ACH2	ARTCORE 2	B	H	C	Bridge version of ACH1.
ACH3	ACH3	N	H	C	Well-balanced classic humbucker tone.
ACH4	ACH4	B	H	C	Well-balanced classic humbucker tone.
ACH1-S	ACH1-S	N	H	C	Tight tone with added treble.
ACH2-S	ACH2-S	B	H	C	Bridge version of ACH1-S.
AH1	AXIS HUMBUCKER 1	N	H	C	Very responsive and full sounding; medium output with lots of character. Excellent for chording.
AH2	AXIS HUMBUCKER 2	B	H	AL	Full bass sound. Alnico-5 magnet provide excellent clarity in harmonics and individual notes.
AH5	AXIS HUMBUCKER 5	N	H	C	Very responsive and full sounding; medium output with lots of character. Excellent for chording.
AH6	AXIS HUMBUCKER 6	B	H	AL	Full bass sound. Alnico-5 magnet provides excellent clarity in harmonics and individual notes.
AH1-7	AXIS HUMBUCKER 1-7	N	H	C	Seven-string version of AH1 pickup.
AH2-7	AXIS HUMBUCKER 2-7	B	H	C	Seven-string version of AH2 pickup.
AHS1	AXIS SINGLE 1	N	S	AL	Traditional sounding single coil pickup with increased output for neck position.
AHS2	AXIS SINGLE 2	M	S	AL	Traditional sounding single coil pickup with increased output for center position.
CCR1	CCR1	N	H	AL	Moderate output. Alnico 8 magnet contributes crispy edge with bright high.
CCR2	CCR2	B	H	AL	Moderate output. Alnico 8 magnet contributes crispy edge with bright high.
GB SPECIAL	GB SPECIAL	B	H	AL	Floating pickup co-designed by George Benson for hollow bodies at higher volumes. Warm, well rounded output with less feedback.
GB SPECIAL	GB SPECIAL	N	H	AL	Neck version of above.
HFS1	HFS1	N	S	C	Single coil's brightness without the susceptibility to hum noise.
HFS2	HFS2	B	S	C	Single coil's brightness without the susceptibility to hum noise.
HGD1	Hot Grinder 1	N	H	AL	Hot, but sharp enough to hear pick bites the strings.
HGD2	Hot Grinder 2	B	H	C	Hot, but sharp enough to hear pick bites the strings.
HS1-N	HS1-N	N	S	AL	Humbucker sized single coil pickup. Loud and crunchy to cut through the mix.
HS1-B	HS1-B	B	S	AL	Humbucker sized single coil pickup. Loud and crunchy to cut through the mix.
INF1	INFINITY 1	N	H	C	Versatile and responsive with warm classic tone and added output.
INF2	INFINITY 2	B	H	AL	Enhanced midrange output. Alnico-5 magnet for individual string clarity. Excellent dynamics.
INF3	INFINITY 3	N	H	C	Provides the dynamic sound for chording and rhythm.
INF4	INFINITY 4	B	H	C	Brilliant lead pickup. Warm sounding with good harmonics.
INFS1	INFINITY SINGLE 1	M	S	AL	Warm single coil tone with added output.
INFS3	INFINITY SINGLE 3	M	S	C	Traditional sounding yet high output. Designed to work with humbuckers in the split position.
LZ1-N	LoZ-N	N	H	C	High output yet low noise, active pickup operated by AA Batteries (3 volts)
LZ1-B	LoZ-B	B	H	C	High output yet low noise, active pickup operated by AA Batteries (3 volts)
LZ3-N	LoZ-N	N	H	C	Active Pickup. High-output fat sound, yet tweaked to produce a balanced clean sound.
LZ3-B	LoZ-B	B	H	C	Active Pickup. High-output fat sound, yet tweaked to produce a balanced clean sound.
LZ4-N	LoZ-N	N	H	AL	Active Pickup. Wide dynamic range from fat & heavy to bright & loud.
LZ4-B	LoZ-B	B	H	C	Active Pickup. Wide dynamic range from fat & heavy to bright & loud.
LZ7-N	LoZ-N	N	H	C	Seven-string version of LZ3 pickup.
LZ7-B	LoZ-B	B	H	C	Seven-string version of LZ3 pickup.
LZ8-N	LoZ-N	N	H	C	Eight-string version of LZ3 pickup.

LZ8-B	LoZ-B	B	H	C	Eight-string version of LZ3 pickup.
PP1-N	PP1-N	N	H	AL	Tube construction of the pole-piece provides quick response, clarity and added harmonics.
PP1-B	PP1-B	B	H	C	Tube construction of the pole-piece provides quick response, clarity and added harmonics.
PSNDS	PSNDS	M/N	S	AL	High output with complete clarity.
PSND1	PSND1	N	H	C	High output in the neck position with no "muddiness."
PSND2	PSND2	B	H	C	High output with enhanced harmonics.
PSND3	PSND3	N	H	AL	High-output with plenty of clarity.
PSND4	PSND4	B	H	C	High-output works for both lead and rhythm.
S1	SINGLE 1	M/N	S	AL	Traditional sounding, but high output single coil with Alnico-5 polepieces for even string output. Designed to work with humbuckers in the split position.
S58	SUPER 58	A11	H	AL	Classic, warm and versatile. Handles both jazz and rock without feedback.
S58C	SUPER 58 Custom	A11	H	AL	Classic, warm and versatile.
SL58	SILENT 58	A11	H	AL	Classic, warm and versatile. Handles both jazz and rock without feedback.
ST2	Short Tracer	M	S	AL	Alnico magnet provides full output in low profile setting.
TDB1	True-Duo Buckler	B/N	H	C/AL	Designed for switching between genuine double and single-coil sound in one pickup.
TDB2	True-Duo Blast 1	N	H	C/AL	Some True-Duo constructions as True-Duo Buckler, but the wiring enables True-Duo function as a pair, Bridge and Neck.
TDB3	True-Duo Blast 2	B	H	C/AL	Some True-Duo constructions as True-Duo Buckler, but the wiring enables True-Duo function as a pair, Bridge and Neck.
V7	V7	N	H	C	Tight, but bright. Very dynamic for chording and rhythm.
V7C	V7 Custom	N	H	AL	Smooth and dynamic tone with warm mid-range.
V8	V8	B	H	AL	Warm yet articulate lead pickup with enhanced overtones. Good harmonics without excessive brightness.
V8C	V8 Custom	B	H	C	Rich, harmonic tone with clarity in low-end.
V77	V77	N	H	C	Seven-string version of V7 pickup.
V77C	V77 Custom	N	H	C	Seven-string version of V7C.
V87	V87	B	H	C	Seven-string version of V8 pickup.
V87C	V87 Custom	B	H	C	Seven-string version of V8C.
VK1-DT	VK-Down Tunz	N	H	AL	High output yet clarity in the high end with V bar polepieces.
VK2-DT	VK-Down Tunz	B	H	AL	High output yet clarity in the high end with V bar polepieces.

IBANEZ BASS PICKUPS					
ACHB-2	ACHB-2	B/N	H/P	C	High output humbucking pickup.
ADX5	ACTIVE DYNAMIX 5	B/N	H/A	C	Quiet, dynamic, punchy sound on all 5 strings. Two different sized bobbins provide even string output. Individually calibrated for neck and bridge positions.
ATK	ATK TRIPLE COIL	B	H/P	C	Heavy bottom and natural high end.
DXH-5	DYNAMIX-5	B/N	H/P	C	Powerful with good midrange punch.
EXF-4	EX FULL RANGE 4	B/N	H/P	C	Balanced tone and sound among each string.
EXF-5	EX FULL RANGE 5	B/N	H/P	C	5-string version of EXF-4.
PFR-4	PASSIVE FULL RANGE	B/N	H/P	C	Powerful full range pickup with added low mids.
PFR-5	PASSIVE FULL RANGE	B/N	H/P	C	Powerful full range pickup with added low mids.
PFR-AL4	PASSIVE FULL RANGE	B/N	H/P	AL	Powerful Alnico magnet pickup with exceptional clarity and very even response.
PFR-AL5	PASSIVE FULL RANGE	B/N	H/P	AL	5-string version of PFR-AL4.
PSJ	POWER SINGE J	B/N	S/P	C	Powerful single sound with sharpness.
PPD4	POWERPOLE DUAL COIL	B/N	H/P	C	Passive bass sound with plenty of punch.
PSNDJ	PSNDJ	B/N	H/P	C	High output with added highs.
PSNDP	PSNDP	B/N	H/P	C	High output with plenty of punch.
SFR-GWB	SONIC FULL RANGE	B/N	H/P	C	Custom wound for GWB35. Quick attack, superior dynamics and added highs.

Frequency Response Curves

Power Curve III (SR Prestige)

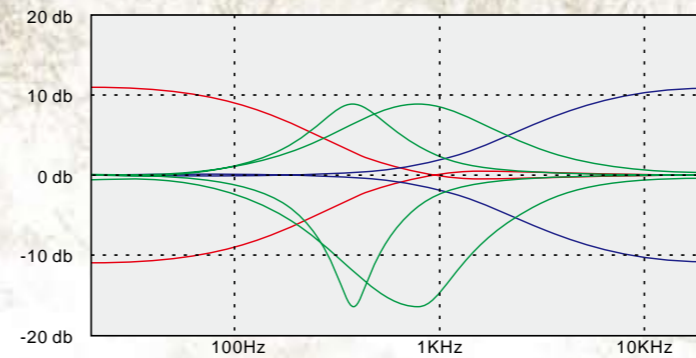

EQB-III B -Style Sweeper- (SR)

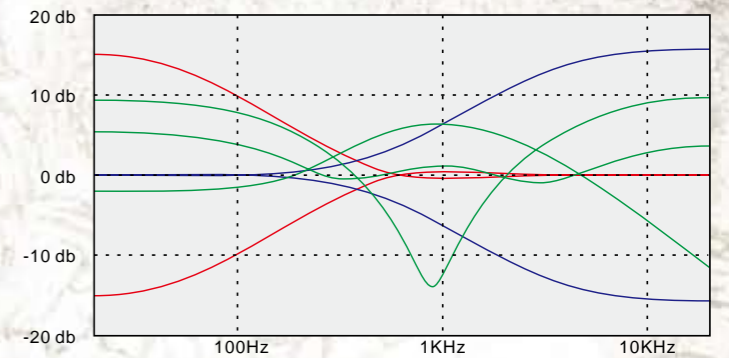

EQB-III S (SR)

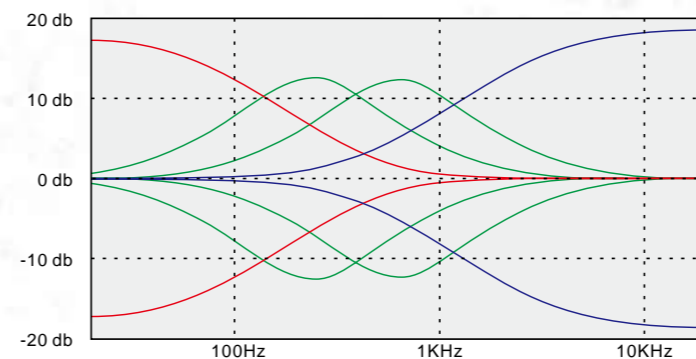

EQB-GWII (GWB35)

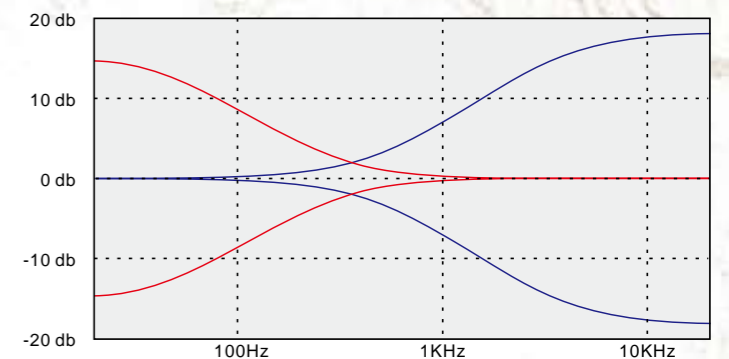

ATK 3 Band EQ (ATK/PGB)

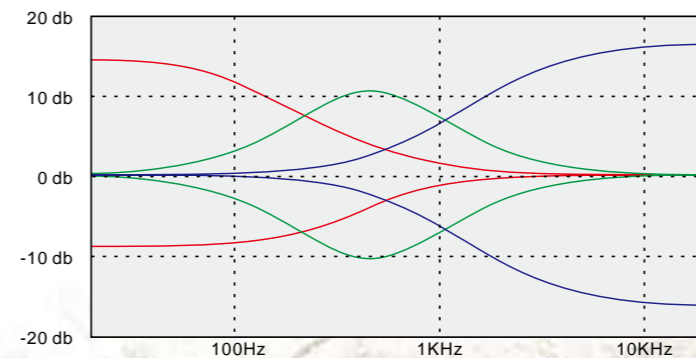

EQB2DX (EDB/ICB/SDB/SRX)

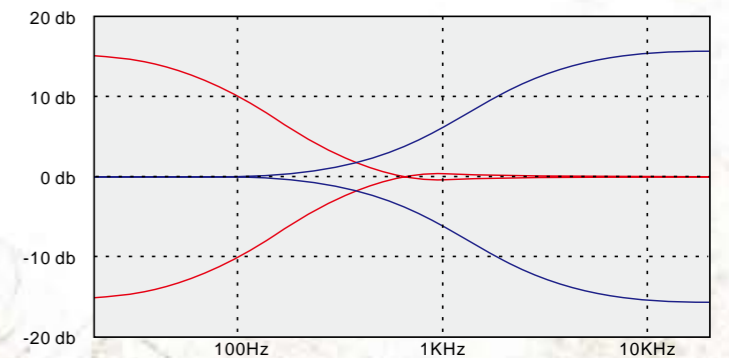

Vari-Mid III (K5/BTB)

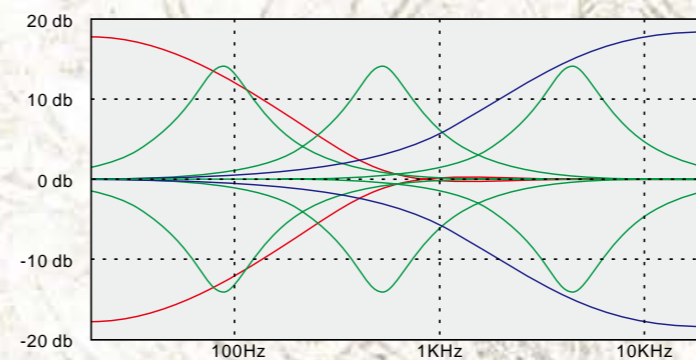

Phat II (ICB/GSR)

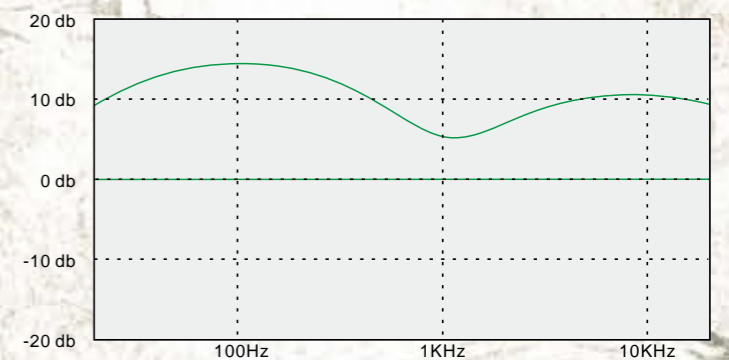

— Bass Boost/Cut — Mid Boost/Cut — Treble Boost/Cut

Switching Systems

H-S-H (5WAY) RG (HSH), JEM, UV, NDM, S (HSH), GRG (HSH)

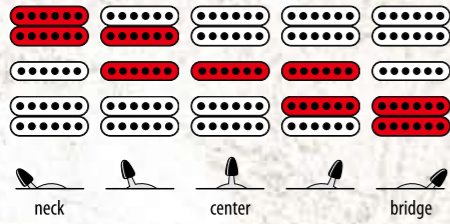

S-S-H (5WAY) GSA

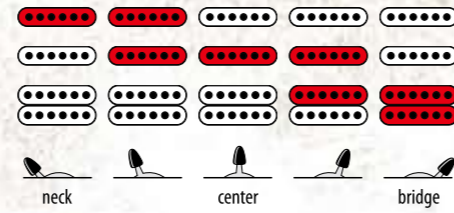

H-S-H (w/True-Duo Blast) SV

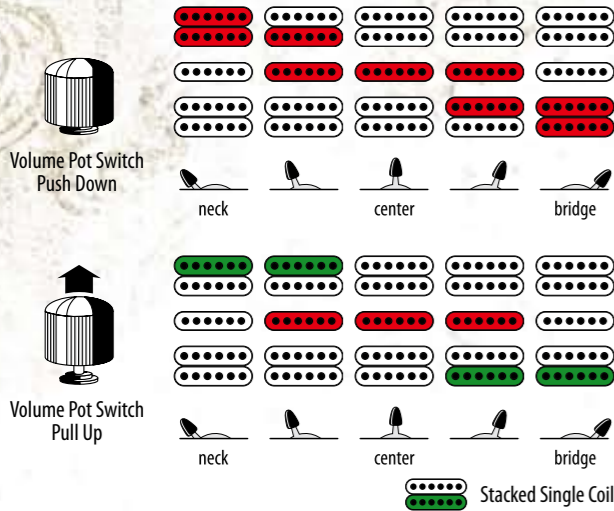

S-S-H (w/True-Duo Bucker) SA (SSH)

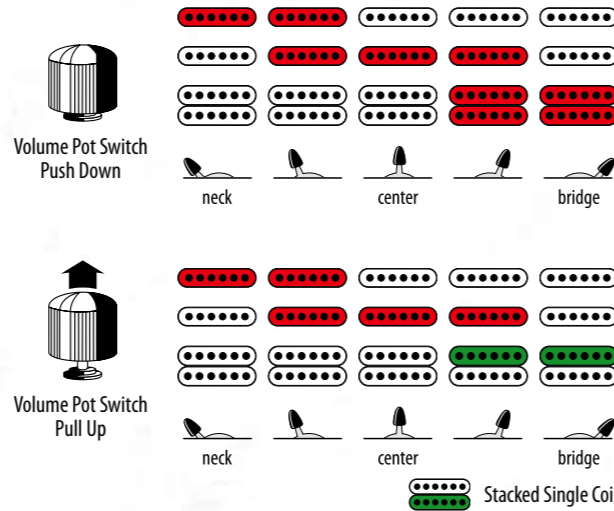

H-S-H (5WAY) EGEN18, EGEN8

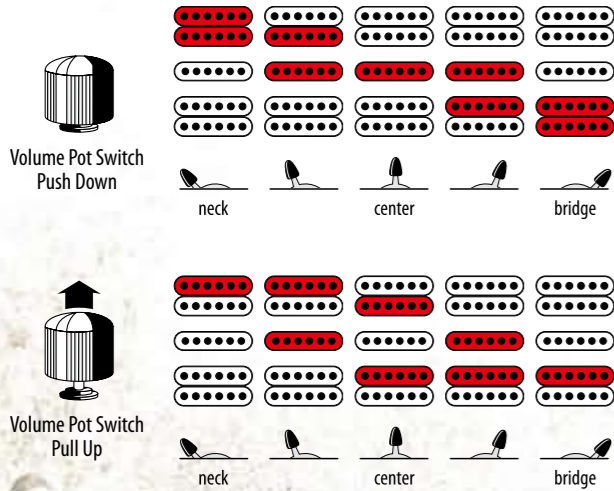

H-H (w/True-Duo Bucker) SA (HH)

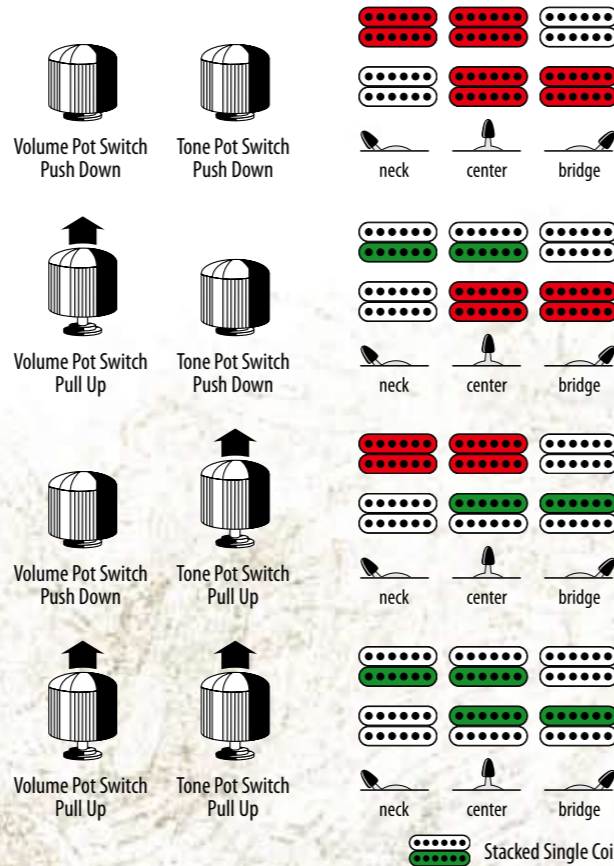

H-H-H (5WAY) AT100CL

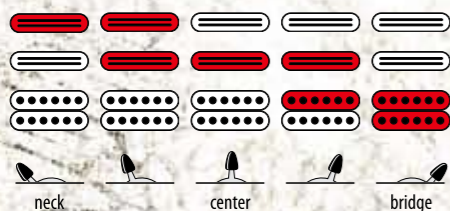

H-H (5WAY) RG (HH), RGD320, S (HH), SA (HH), XP300 (HH)

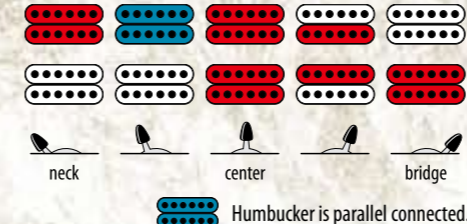

H-H (5WAY) FR

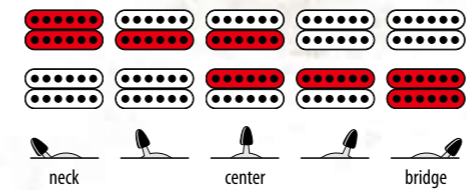

H-H (5WAY) PGM

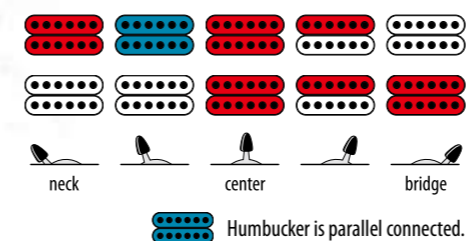

H-H (3WAY) JS2400

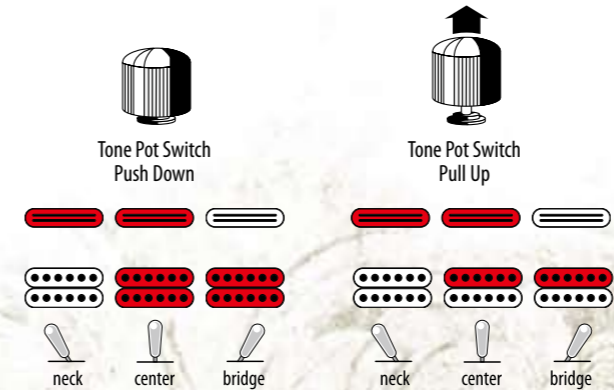

H-H (3WAY) DN500, DN520K, JS1600, JS1200, JS1000, JS100

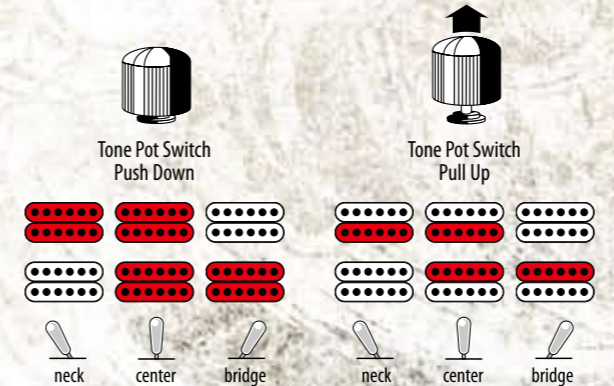

H-H (3WAY) AR, ART, ARTCORE, DTT, GAX, APEX, GB (HH), GRGM, GRGR, JSM, JTK40, MBM, MTM, PM120, RG (w/EMG*), RGA, RGD Prestige, XPT (HH), ICT, STM, XP300FX

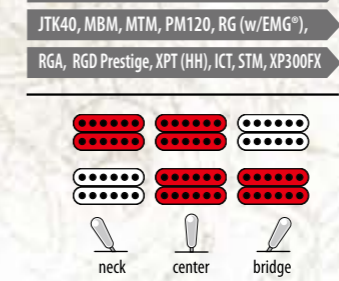

H-H (3WAY) XPT700XH

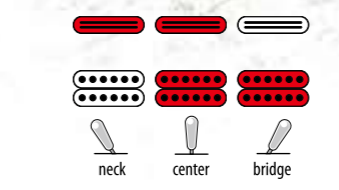

S-S (3WAY) JTK30, DN600

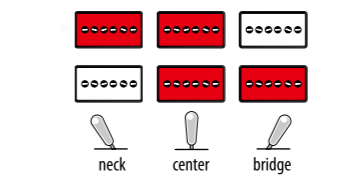

H (2WAY) GB15

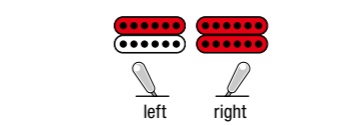

Neck Dimensions

NECK MODEL	SCALE LENGTH	WIDTH AT				RADIUS
		WUT	LAST FRET	1ST FRET	12TH FRET	
GUITAR NECK DIMENSIONS						
APEX	648mm/25.5"	48mm	68mm	19mm	21mm	430mmR
APEX2	648mm/25.5"	48mm	68mm	19mm	21mm	305mmR
AR	628mm/24.75"	43mm	57mm	20mm	22mm	305mmR
AR250/200	628mm/24.75"	43mm	57mm	20mm	22.5mm	305mmR
ART	628mm/24.75"	43mm	57mm	20mm	22mm	305mmR
ARTCORE	628mm/24.75"	43mm	57mm	20mm	22mm(21.5)	305mmR
AT	648mm/25.5"	40.5mm	57mm	21mm	23mm	305mmR
DN	628mm/24.75"	43mm	57mm	20mm	22.5mm	305mmR
EGEN	648mm/25.5"	43mm	58mm	18mm	20mm	430mmR
GAX1	628mm/24.75"	43mm	57mm	20mm	22mm	400mmR
GB	628mm/24.75"	43mm	57mm	20mm	23mm	305mmR
GB15	628mm/24.75"	44mm	58mm	20mm	23mm	305mmR
GRG1	648mm/25.5"	43mm	58mm	19.5mm	21.5mm	400mmR
GRG2	648mm/25.5"	43mm	58mm	19.5mm	21.5mm	400mmR
GRGM	560mm/22"	42mm	56mm	20.5mm	23mm	400mmR
GSA	648mm/25.5"	43mm	57mm	19.5mm	21.5mm	400mmR
JEM	648mm/25.5"	43mm	58mm	18mm	20mm	430mmR
JS	648mm/25.5"	42mm	58mm	20mm	22.3mm	250mmR
JS100	648mm/25.5"	42mm	57mm	20mm	22mm	400mmR
JSM	628mm/24.75"	43.5mm	57mm	20.2mm	23.3mm	COMPOUND
JTK	648mm/25.5"	43mm	56mm	21.5mm	23mm	305mmR
MBM	648mm/25.5"	43mm	58mm	18mm	20mm	430mmR
NDM	648mm/25.5"	42mm	57mm	20mm	22mm	240mmR
ORM	610mm/24.0"	43mm	57mm	20.5mm	23mm	305mmR
PGM	648mm/25.5"	43mm	58mm	18mm	20mm	430mmR
PM	628mm/24.75"	43mm	57mm	21mm	23mm	305mmR
PM35	628mm/24.75"	43mm	57mm	20mm	22mm(21.5)	305mmR
SA/SAS	648mm/25.5"	43mm	56mm(21.5)	20.5mm	23mm	400mmR
SUPER WIZARD HP	648mm/25.5"	43mm	58mm	17mm	19mm	430mmR
ULTRA HP	648mm/25.5"	43mm	58mm	18mm	20mm	430mmR
ULTRA-8	685.8mm/27"	54mm	78mm	20mm	21.5mm	430mmR
UV	648mm/25.5"	48mm	68mm	19mm	21mm	430mmR
WIZARD HP	648mm/25.5"	43mm	58mm	18mm	20mm	430mmR
WIZARD HP (RGD2120Z)	672mm/26.5"	43mm	58mm	18mm	20mm	430mmR
WIZARD II	648mm/25.5"	43mm	58mm	19mm	21mm	400mmR
WIZARD II (RGD)	672mm/26.5"	43mm	58mm	19mm	21mm	400mmR
WIZARD II-7	648mm/25.5"	48mm	68mm	19mm	21mm	400mmR
WIZARD II-8	685.8mm/27"	55mm	80mm	20mm	21.5mm	400mmR
WIZARD-7	648mm/25.5"	48mm	68mm	19mm	21mm	430mmR
WIZARD-7 (RGD2127Z)	672mm/26.5"	48mm	68mm	19mm	21mm	400mmR
BASS NECK DIMENSIONS						
ARTB4	770mm/30.3"	42mm	63mm	21.5mm	24.5mm	305mmR
ARTCORE	770mm/30.3"	42mm	63mm	21.5mm	24.5mm	305mmR
ATK4	864mm/34"	42.5mm	63mm	21mm	24mm	305mmR
ATLAS-4 HP	864mm/34"	38mm	60mm	19.5mm	22.5mm	305mmR
ATLAS-5 HP	864mm/34"	45mm	67mm	19.5mm	23mm	305mmR
ATLAS-6 HP	864mm/34"	54mm	83mm	19.5mm	23mm	500mmR
BTB4	889mm/35"	41mm	64mm	20mm	22mm	305mmR
BTB5	889mm/35"	47mm	76mm	20mm	22mm	400mmR
BTB6	889mm/35"	54mm	88mm	20mm	22mm	400mmR
EDB4	864mm/34"	38mm	62mm	20.5mm	22mm	305mmR
EDB5	864mm/34"	45mm	67mm	20.5mm	22mm	305mmR
GSR4	864mm/34"	41mm	62mm	21mm	22mm	305mmR
GSR5	864mm/34"	45mm	67mm	21mm	22mm	305mmR
GWB1005	864mm/34"	45mm	67mm	19mm	21mm	305mmR
GWB35	864mm/34"	45mm	67mm	19mm	21mm	305mmR
ICB4	864mm/34"	40mm	64mm	20mm	23mm	400mmR
JTKB	864mm/34"	40mm	64mm	20mm	23mm	400mmR
K5	864mm/34"	45mm	67mm	19.5mm	21.5mm	305mmR
MDB4	864mm/34"	38mm	62mm	21mm	23mm	305mmR
PGB4	864mm/34"	42.5mm	63mm	21mm	24mm	240mmR
PIB5	864mm/34"	45mm	67mm	21.5mm	23.5mm	305mmR
PRB4	864mm/34"	38mm	62mm	20.5mm	23mm	305mmR
SDB4	864mm/34"	43mm	60mm	22.5mm	22.5mm	305mmR
SR4	864mm/34"	38mm	62mm	19.5mm	21.5mm	305mmR
SR5	864mm/34"	45mm	67mm	19.5mm	21.5mm	305mmR
SR6	864mm/34"	54mm	83mm	19.5mm	21.5mm	400mmR
SRX4	864mm/34"	38mm	62mm	21mm	23mm	305mmR
SRX5	864mm/34"	45mm	73mm	21mm	23mm	400mmR

Finishes

