

## CAPTAIN'S INSTRUMENT PANEL - DESCRIPTION AND OPERATION

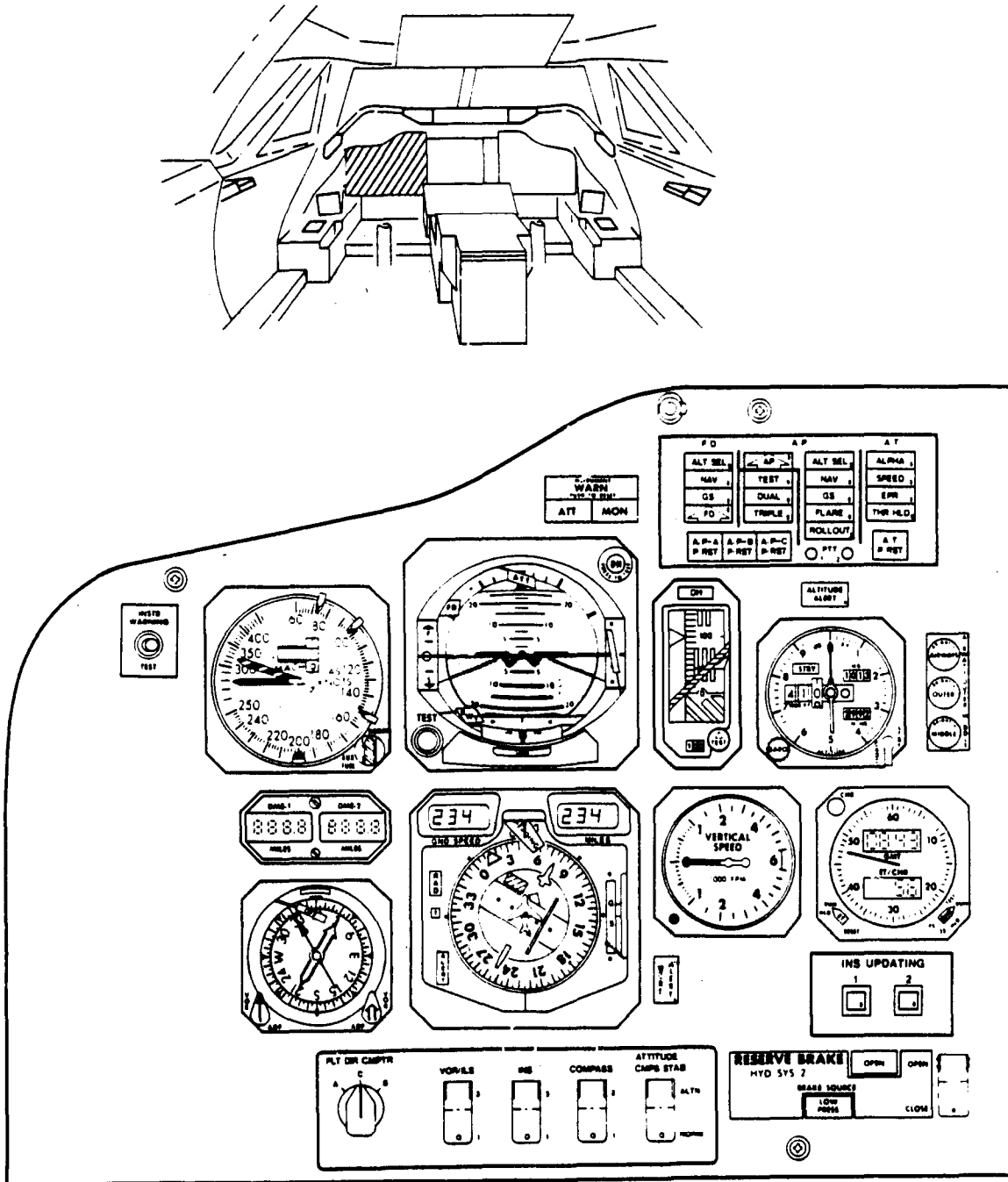

P1

FIGURE 1 - CAPTAIN'S INSTRUMENT PANEL

TMA 85555/R/4465R

END

EFF

N151UA-52UA

MM 747-200  
CONFIG. 1

31-11-11  
PAGE 1  
JAN 29/91

## CAPTAIN'S INSTRUMENT PANEL - DESCRIPTION AND OPERATION

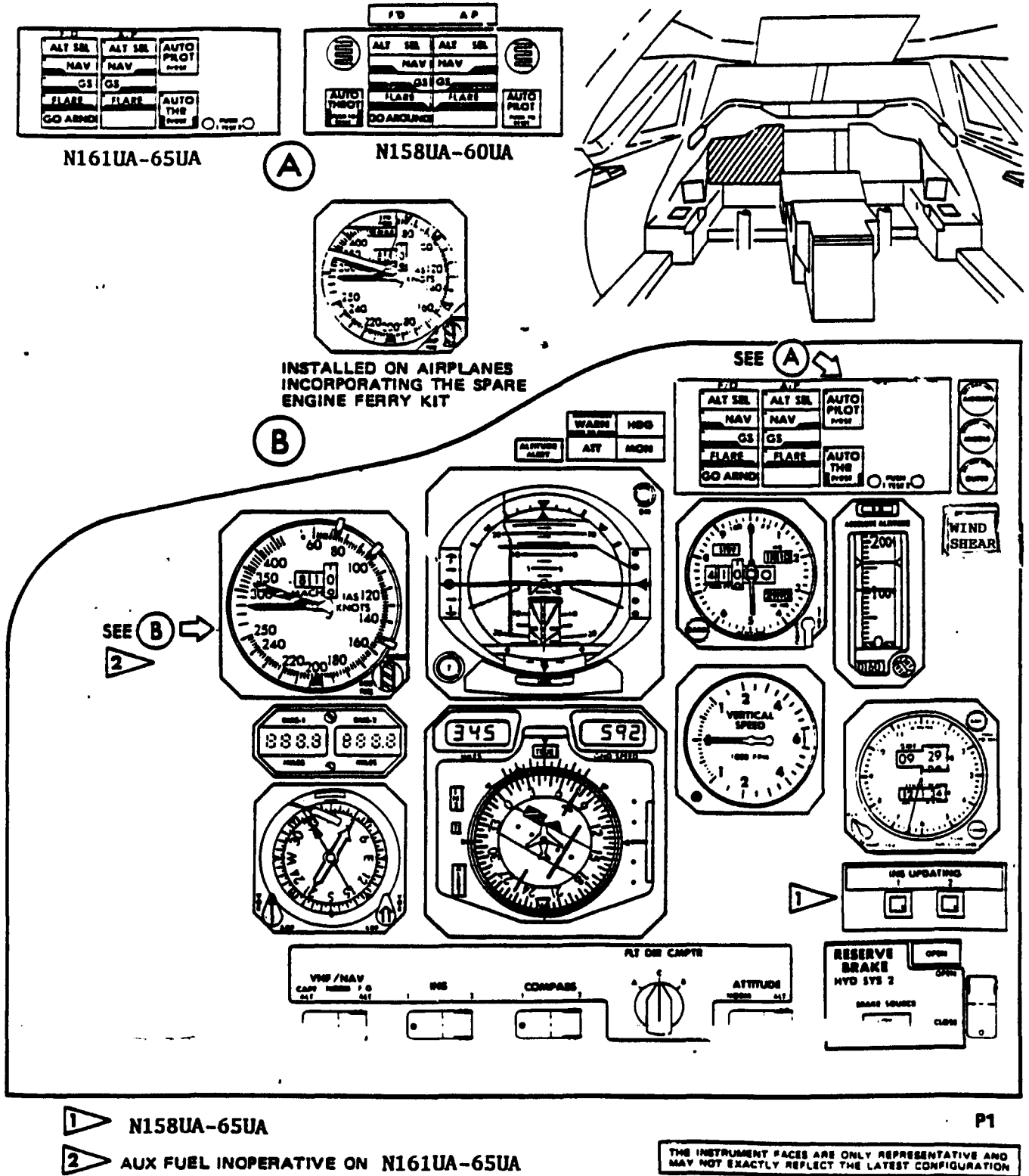

FIGURE 1 - CAPTAIN'S INSTRUMENT PANEL

TMA 4391/R/4466R

END

EFF.

N158UA-65UA

MM 747-200  
CONFIG. 2

31-11-11  
PAGE 1  
SEP 29/93

## PILOTS' CENTER INSTRUMENT PANEL - DESCRIPTION AND OPERATION

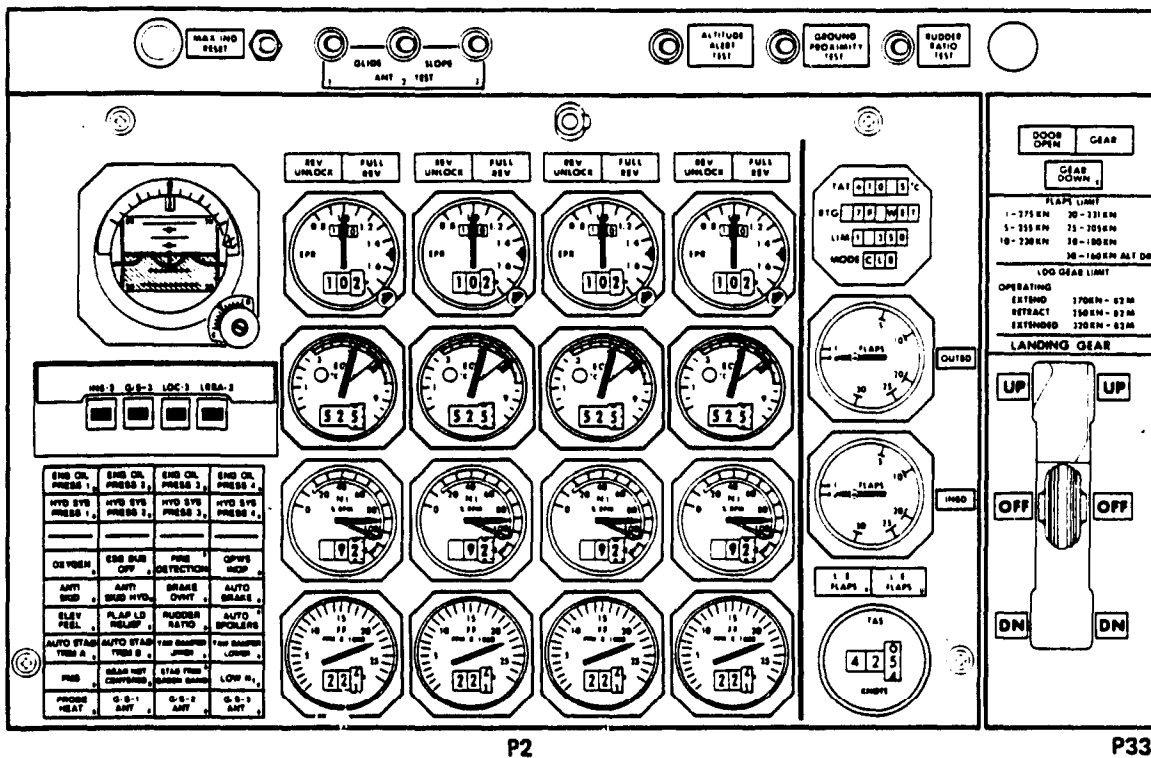
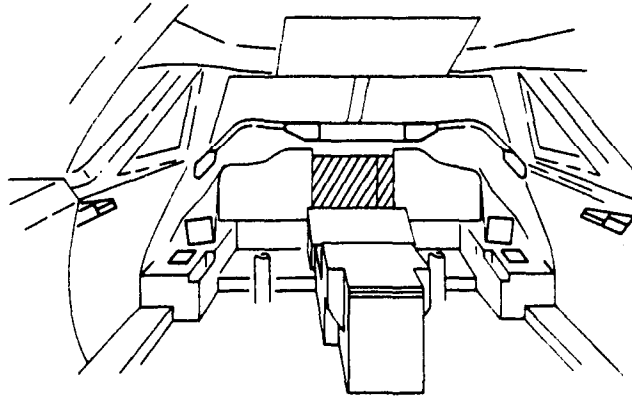

FIGURE 1 - PILOTS' CENTER INSTRUMENT PANEL

TMA 85555/R/4467R

END

EFF

N151UA-52UA

MM 747-200  
CONFIG. 1

31-11-16  
PAGE 1  
JAN 29/91

## PILOTS' CENTER INSTRUMENT PANEL - DESCRIPTION AND OPERATION

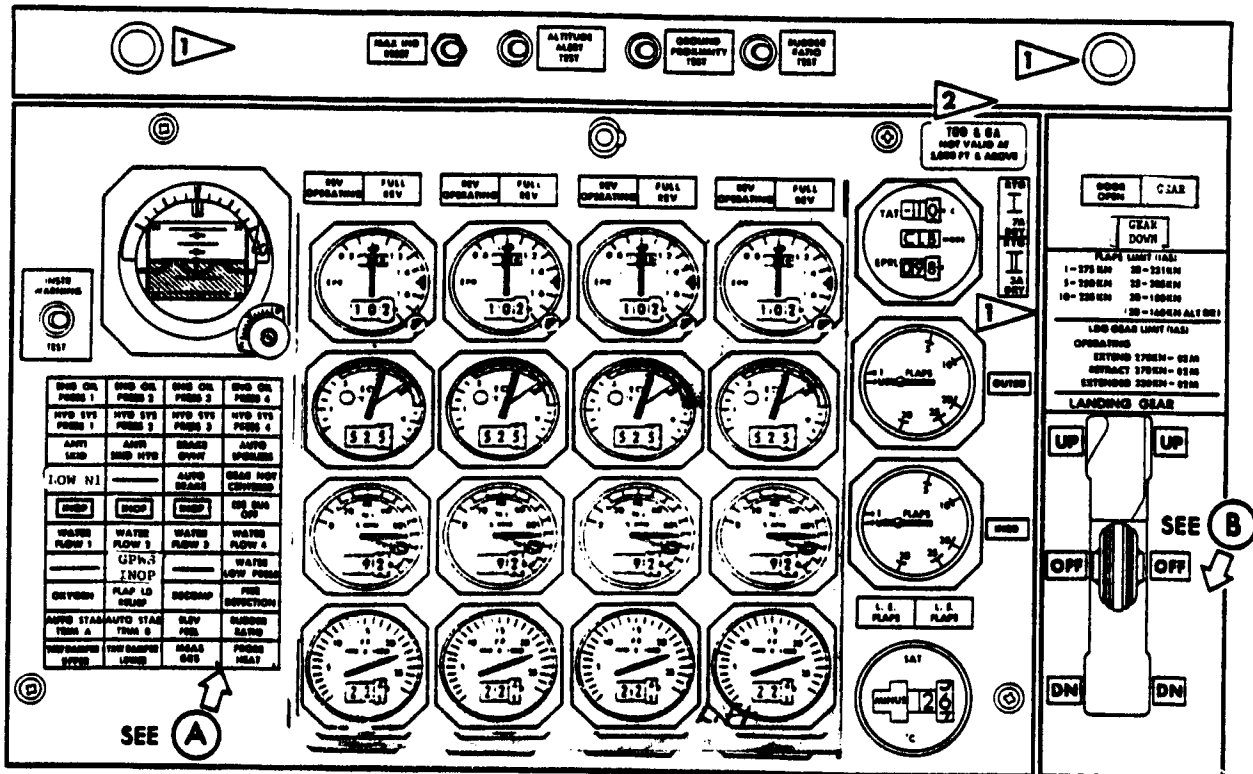
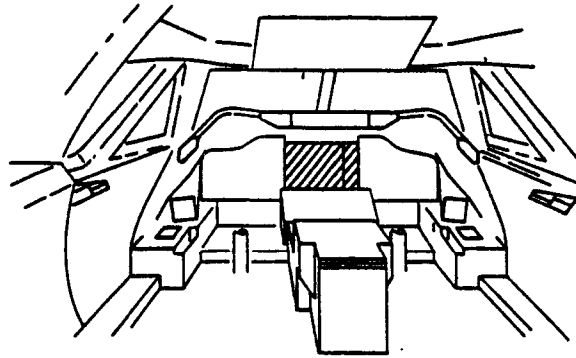

1 N161UA-65UA  
2 N158UA-60UA

PROBE HEAT

N158UA-60UA

(A)

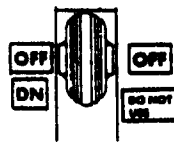

N159UA

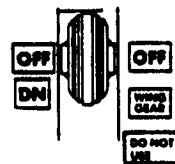

N160UA

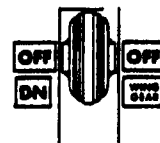

N158UA

(B)

FIGURE 1 - PILOTS' CENTER INSTRUMENT PANEL

TMA 4391/R/4468R

END

EFF.

N158UA-65UA

MM 747-200  
CONFIG. 2

31-11-16  
PAGE 1  
SEP 29/93

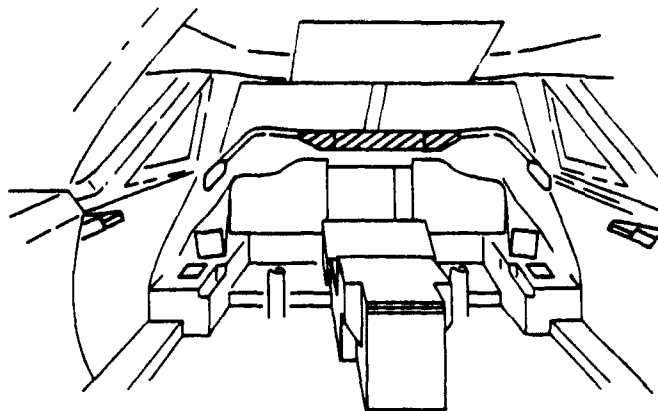

1 "CARGO DOORS" INSTALLED ON AIRPLANES WITH SB 52-2224

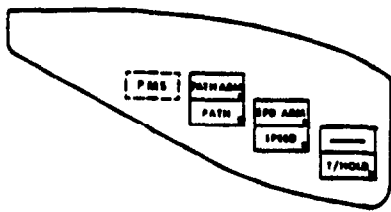
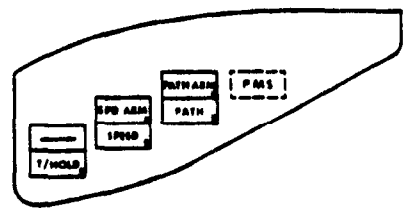
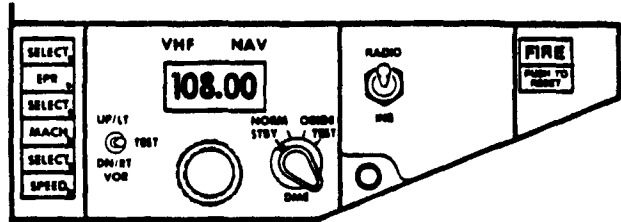
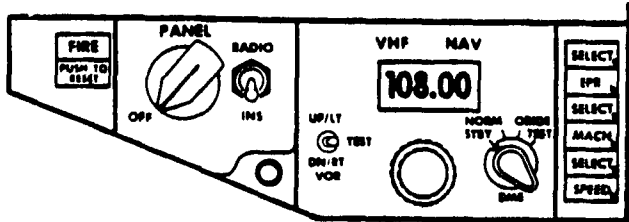
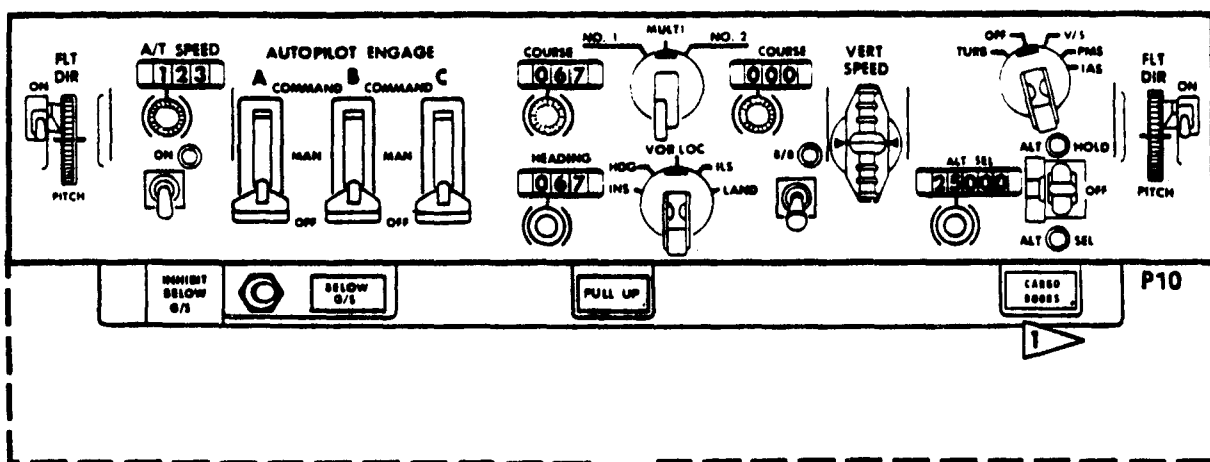

FIGURE 1 - PILOTS' AUTOMATIC FLIGHT CONTROL PANEL

TMA 2521/A/4469R

END

EFF.

N151UA-52UA

MM 747-200  
CONFIG. 1

31-11-21  
PAGE 1  
JUL 20/92

## PILOTS' AUTOMATIC FLIGHT CONTROL PANEL - DESCRIPTION AND OPERATION

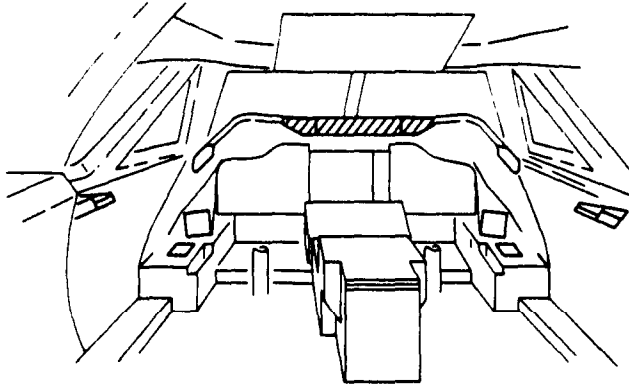

- 1 A/T ENGAGE SWITCH INOPERATIVE ON AIRPLANES INCORPORATING SB 71-2182
- 2 SWITCH PANEL ON N158UA-65UA
- 3 "MACH" SWITCH POSITION ON N161UA-65UA

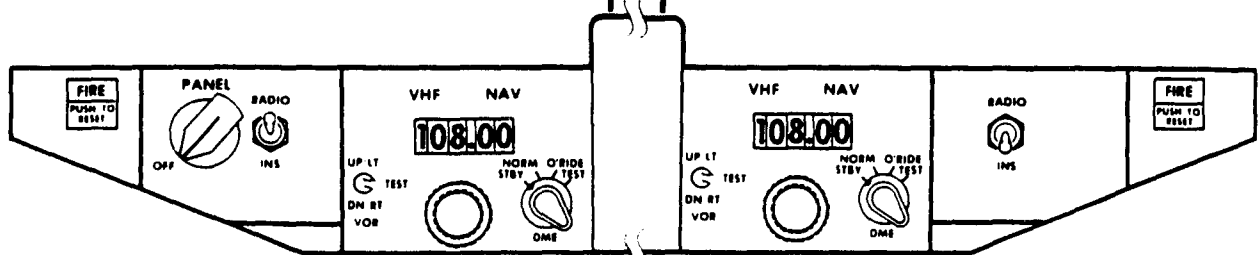
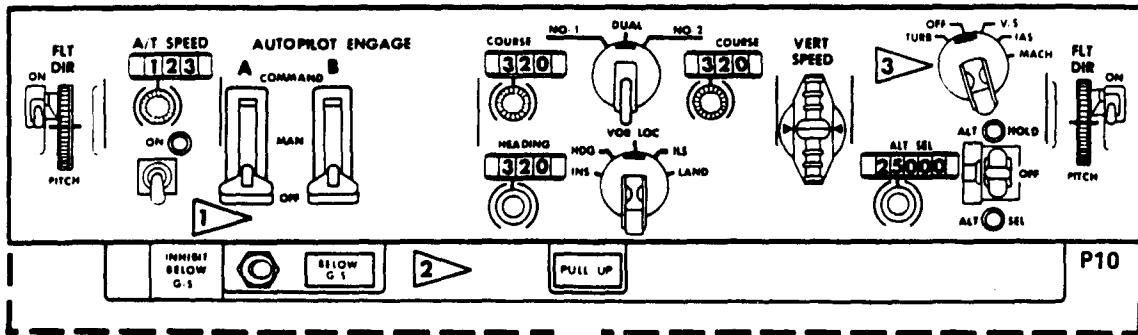

N158UA-63UA

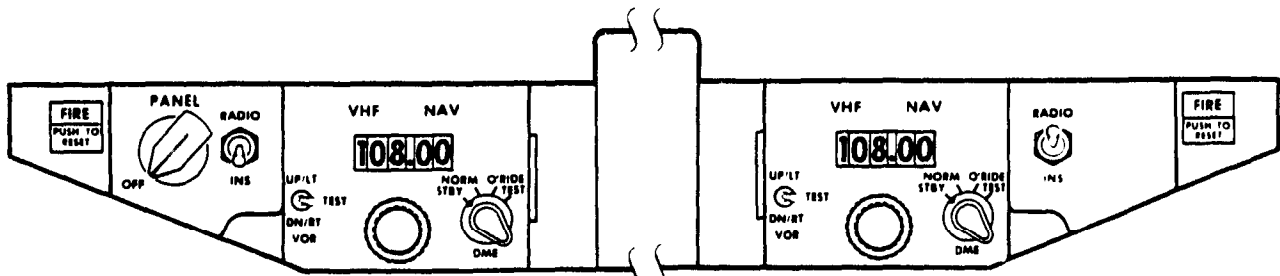

N164UA-65UA

THE INSTRUMENT FACES ARE ONLY REPRESENTATIVE AND MAY NOT EXACTLY REFLECT THE LATEST CONFIGURATION

FIGURE 1 (SHEET 1) - PILOTS' AUTOMATIC FLIGHT CONTROL PANEL

TMA 85555/0/4470R

END

EFF.

N158UA-65UA

MM 747-200  
CONFIG. 2

31-11-21  
PAGE 1  
JAN 29/91

## FIRST OFFICER'S INSTRUMENT PANEL - DESCRIPTION AND OPERATION

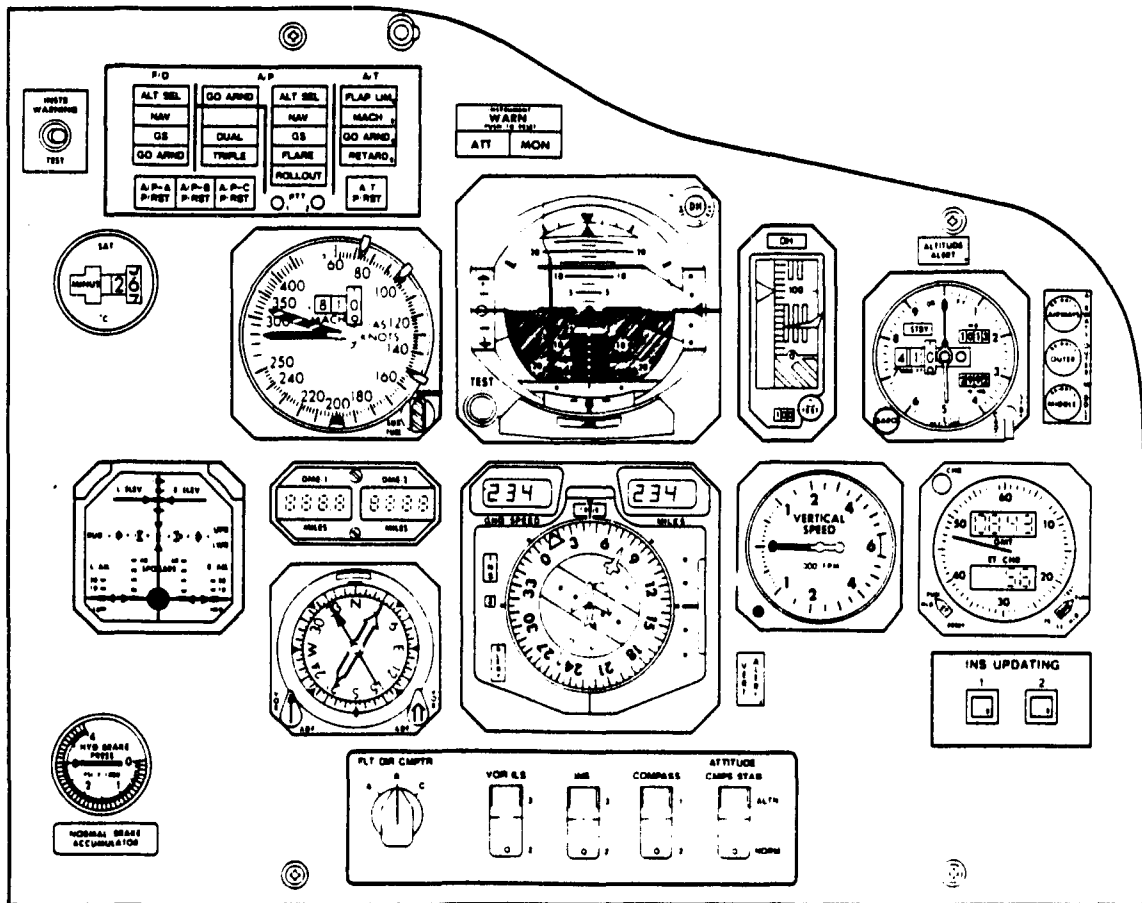
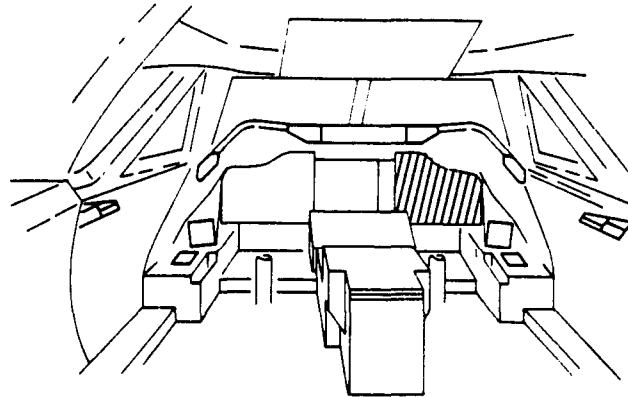

P3

FIGURE 1 - FIRST OFFICER'S INSTRUMENT PANEL

TMA 85555/R/4471R

END

EFF.

N151UA-52UA

MM 747-200  
CONFIG. 1

31-11-26  
PAGE 1  
APR 15/75

# UNITED AIRLINES

## FIRST OFFICER'S INSTRUMENT PANEL - DESCRIPTION AND OPERATION

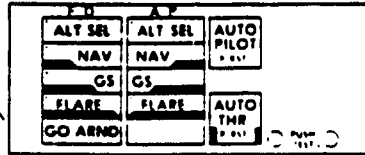
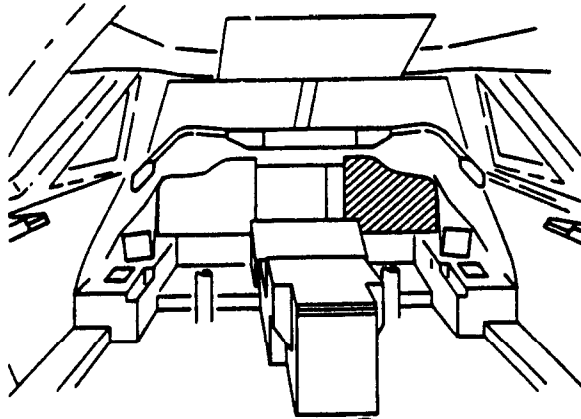

N161UA-65UA

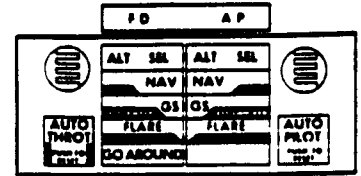

N158UA-60UA

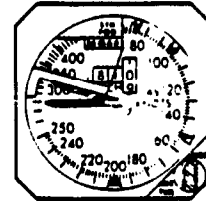

INSTALLED ON AIRPLANES INCORPORATING THE SPARE ENGINE FERRY KIT

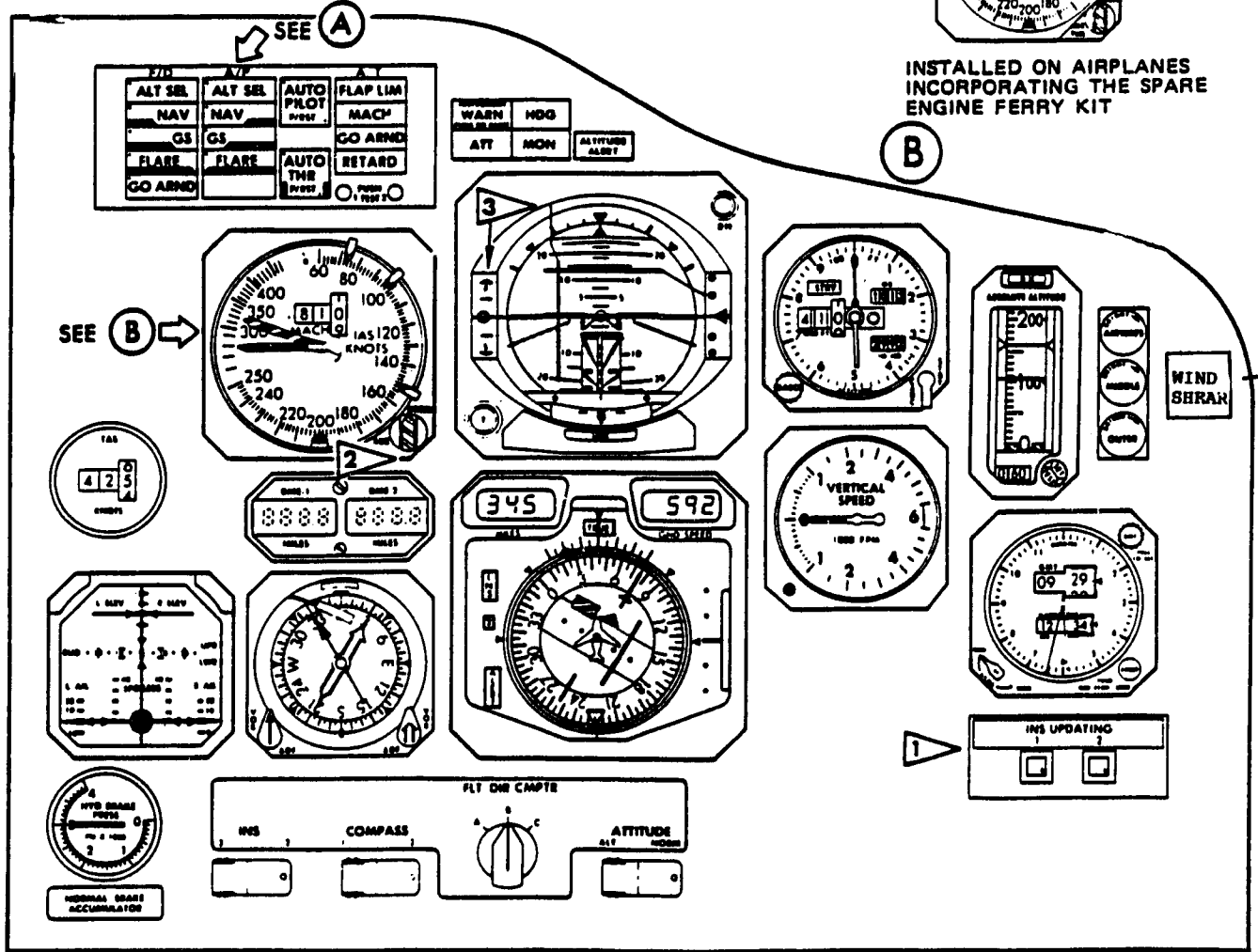

1 N158UA-65UA

2 AUX FUEL INOPERATIVE ON N161UA-65UA

THE INSTRUMENT FACES ARE ONLY REPRESENTATIVE AND MAY NOT EXACTLY REFLECT THE LATEST CONFIGURATION

FIGURE 1 - FIRST OFFICER'S INSTRUMENT PANEL

TMA 4391/R/4472R

END

EFF.

N158UA-65UA

MM 747-200  
CONFIG. 2

31-11-26  
PAGE 1  
SEP 29/93



## CONTROL STAND FWD ELECTRONICS PANEL - DESCRIPTION AND OPERATION

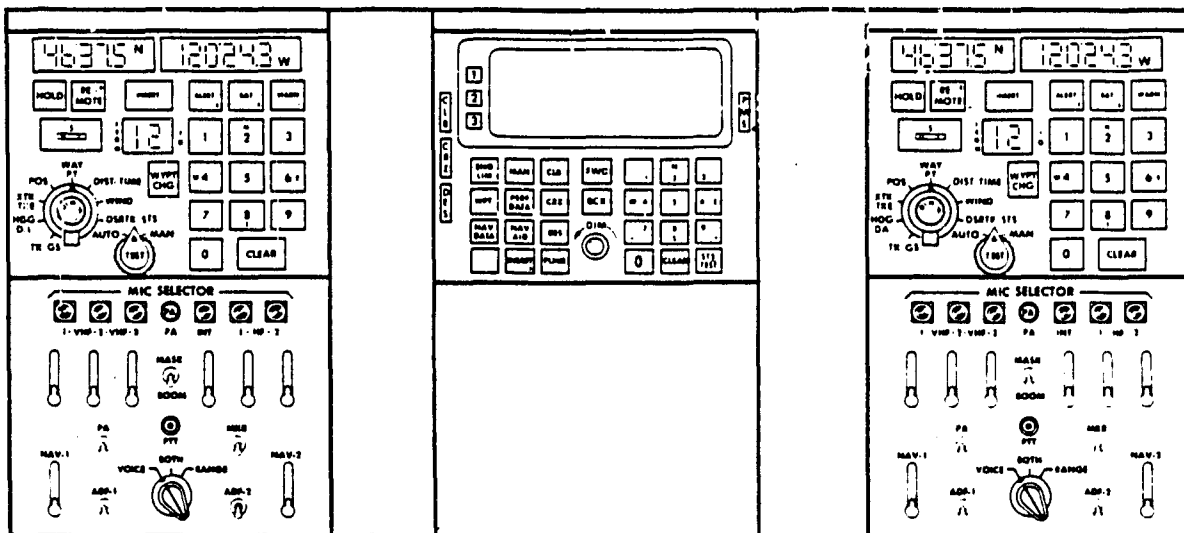
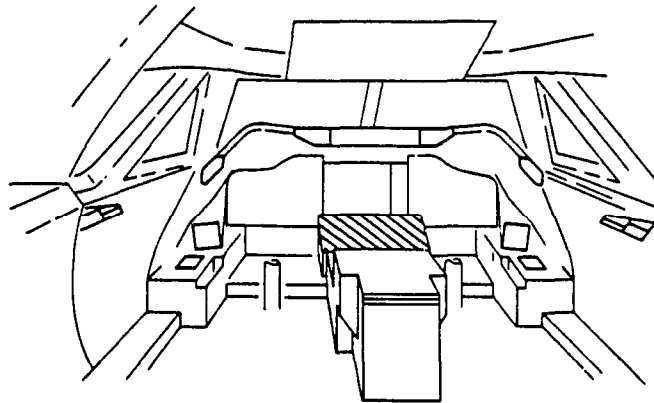

P9

FIGURE 1 - CONTROL STAND FWD ELECTRONIC PANEL

TMA 85555/R/4473R

END

EFF.

N151UA-52UA

MM 747-200  
CONFIG. 1

31-11-31  
PAGE 1  
JAN 29/91

## CONTROL STAND FWD ELECTRONICS PANEL - DESCRIPTION AND OPERATION

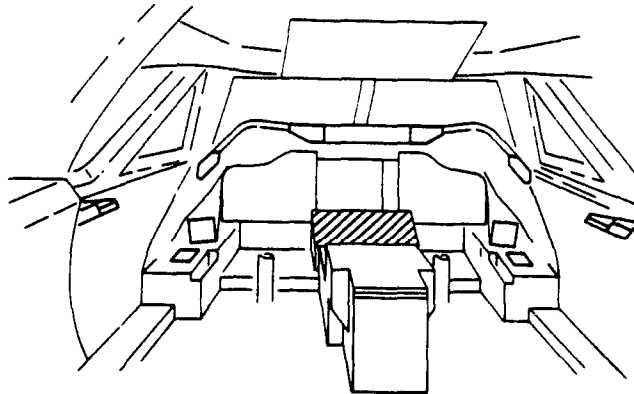

**NOTE:** MAKE WIDTH OF LIGHT  
AS NARROW AS POSSIBLE

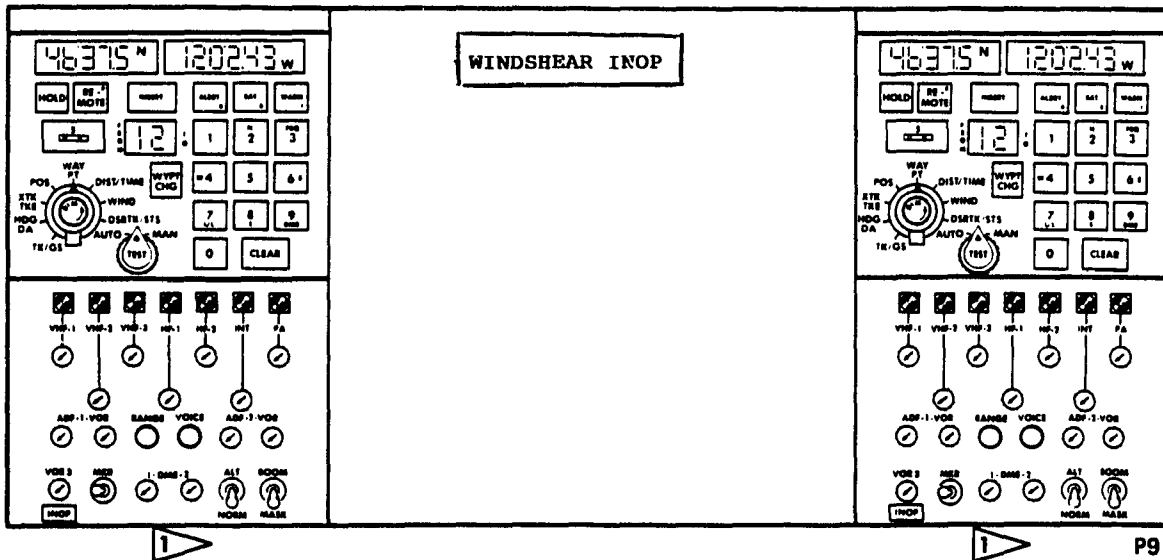

1 ATC INOPERATIVE ON  
N164UA-65UA

FIGURE 1 - CONTROL STAND FWD ELECTRONICS PANEL

TMA 4391/R/4474R

END

EFF.

N158UA-65UA

MM 747-200  
CONFIG. 2

31-11-31  
PAGE 1  
SEP 29/93

## CONTROL STAND AFT ELECTRONICS PANEL - DESCRIPTION AND OPERATION

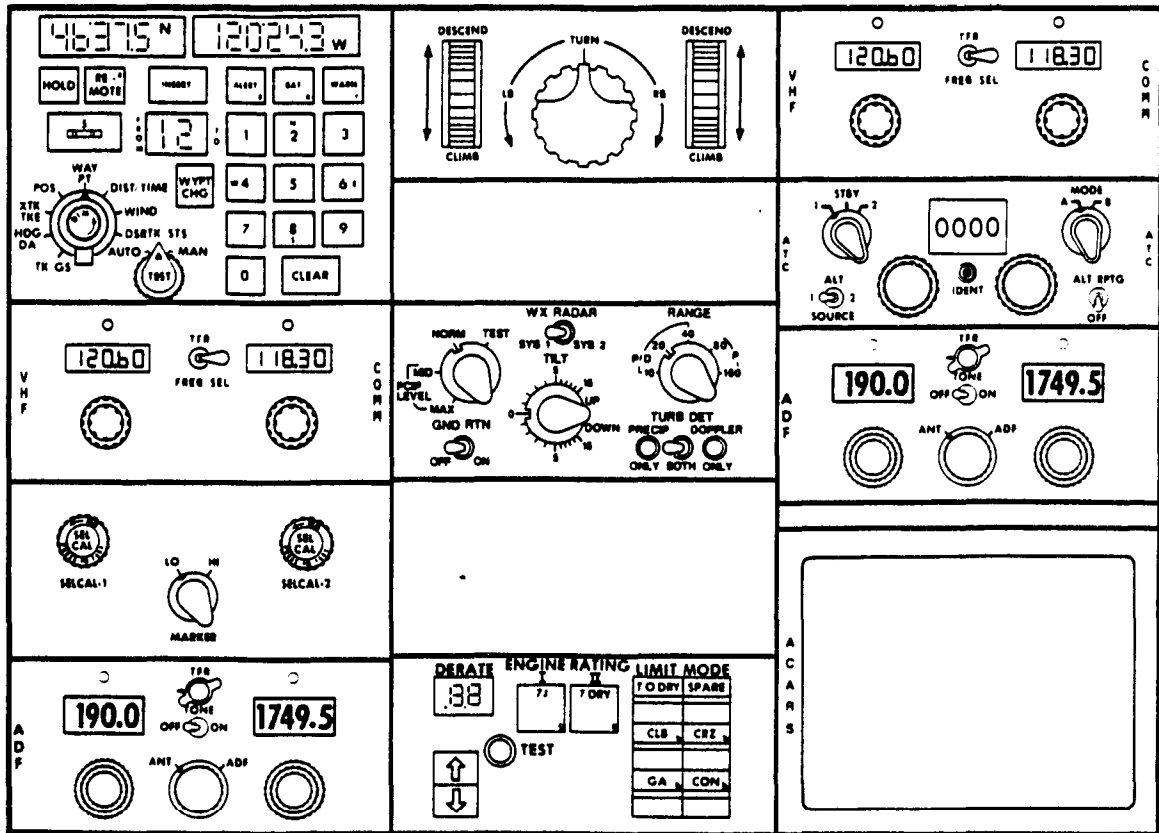
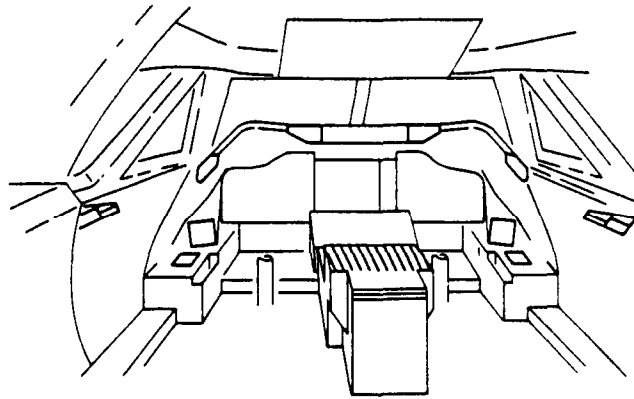

P8

FIGURE 1 - CONTROL STAND AFT ELECTRONICS PANEL

TMA 85555/R/4475R

END

EFF.

N151UA-52UA

MM 747-200  
CONFIG. 1

31-11-36  
PAGE 1  
JAN 29/91

# UNITED AIRLINES

## CONTROL STAND AFT ELECTRONICS PANEL - DESCRIPTION AND OPERATION

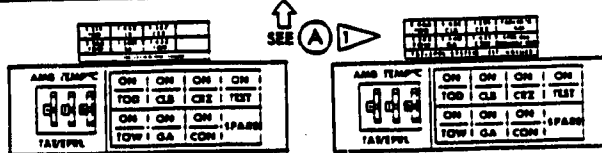
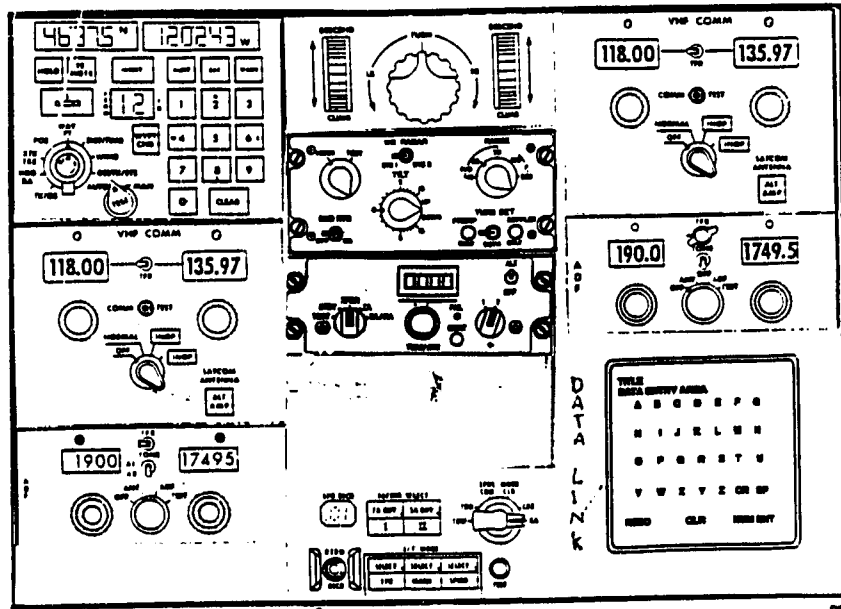
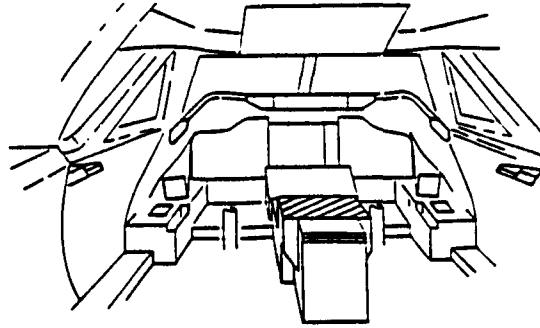

N158UA-59UA

N160UA ONLY

▶ EPR DECR. RTRN/LEC. SWITCH AND A/T MODE LABELED DEACTIVATED ON N161UA

THE INSTRUMENT FACES ARE ONLY REPRESENTATIVE AND MAY NOT EXACTLY REFLECT THE LATEST CONFIGURATION

FIGURE 1 - CONTROL STAND AFT ELECTRONICS PANEL

TMA 0277/K/4476R

END

EFF.

N158UA-65UA  
Before COA 8-4216

MM 747-200  
CONFIG. 2

31-11-36  
PAGE 1  
FEB 02/94

# UNITED AIRLINES

## CONTROL STAND AFT ELECTRONICS PANEL - DESCRIPTION AND OPERATION

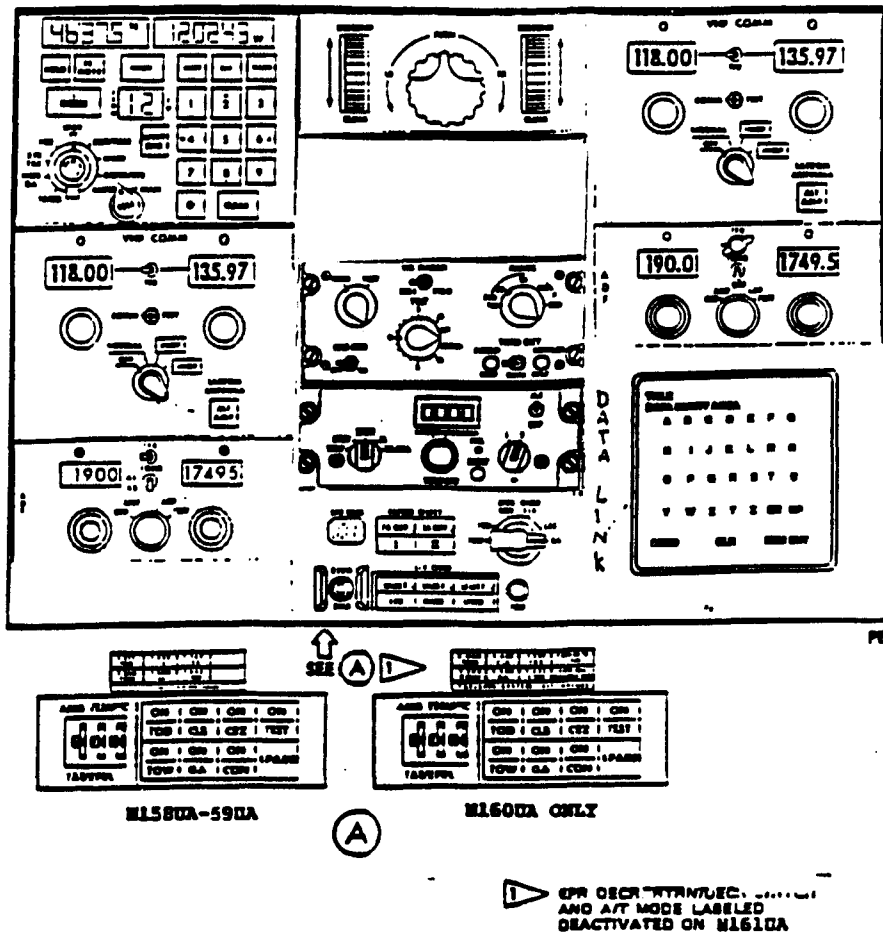
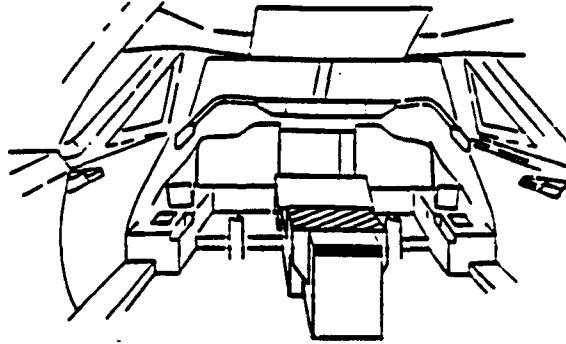

FIGURE 1 - CONTROL STAND AFT ELECTRONICS PANEL

TMA 0277/K/6517R

END

EFF.

N158UA-65UA  
After COA 8-4216

MM 747-200  
CONFIG. 3

31-11-36  
PAGE 1  
FEB 02/94

## PILOTS' CONTROL STAND - DESCRIPTION AND OPERATION

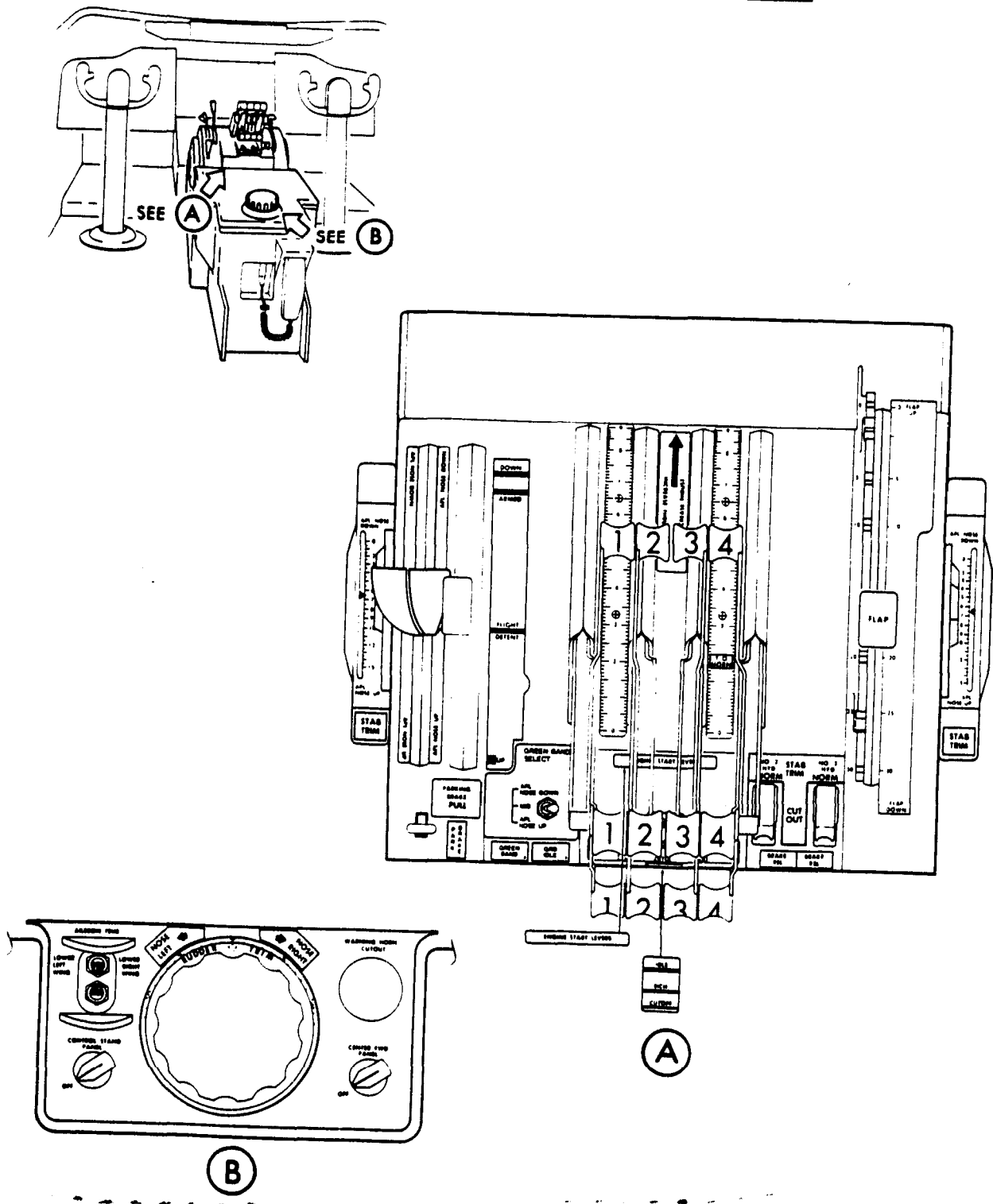

FIGURE 1 - PILOTS' CONTROL STAND

TMA 85555/R/4477R

END

EFF.

N151UA-52UA

MM 747-200  
CONFIG. 1

31-11-41  
PAGE 1  
JAN 29/91

## PILOTS' CONTROL STAND - DESCRIPTION AND OPERATION

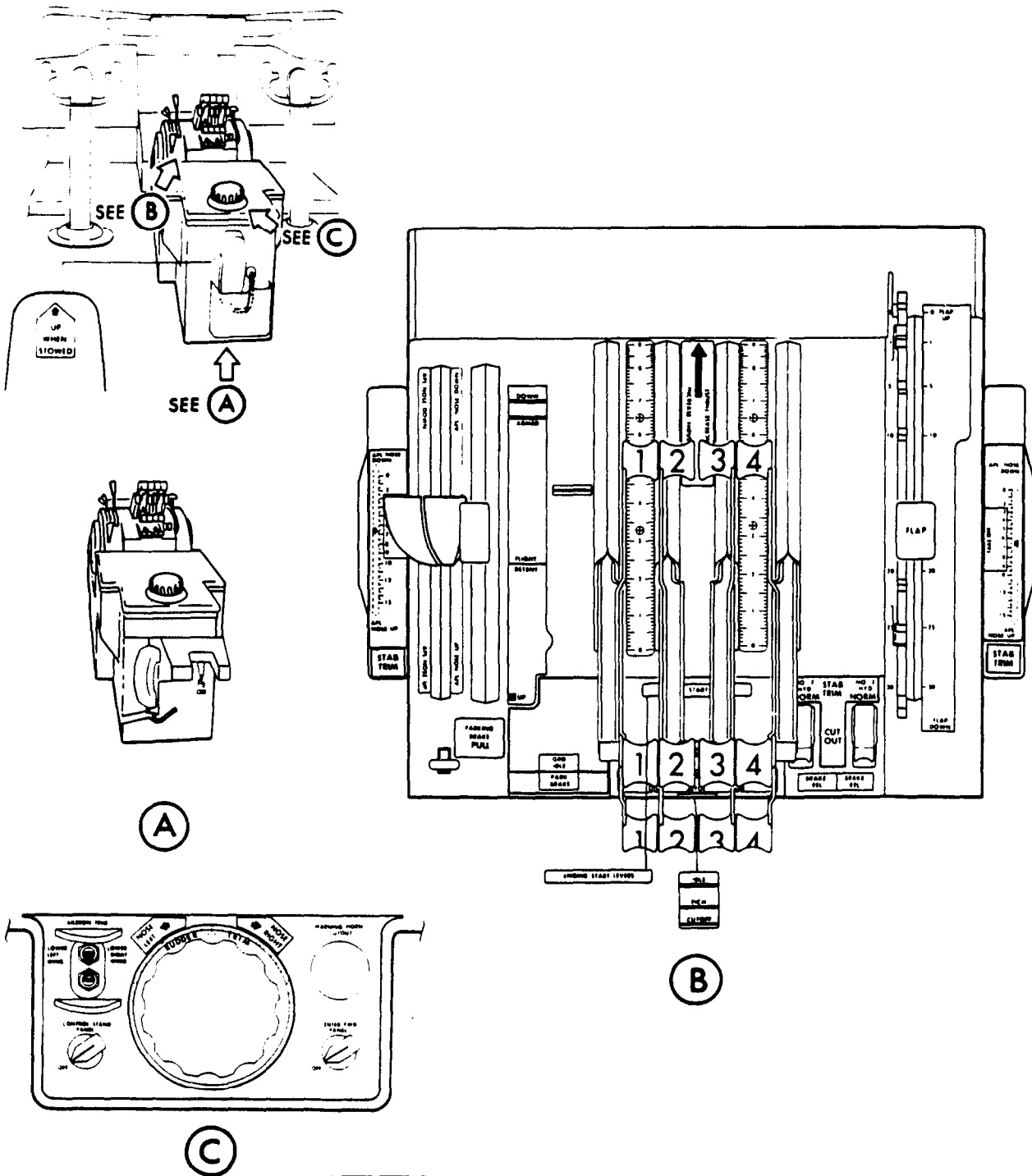

FIGURE 1 - PILOTS' CONTROL STAND

TMA 85555/R/4478R

END

EFF

N158UA-65UA

MM 747-200  
CONFIG. 2

31-11-41  
PAGE 1  
JAN 29/91

## PILOTS' OVERHEAD PANEL - DESCRIPTION AND OPERATION

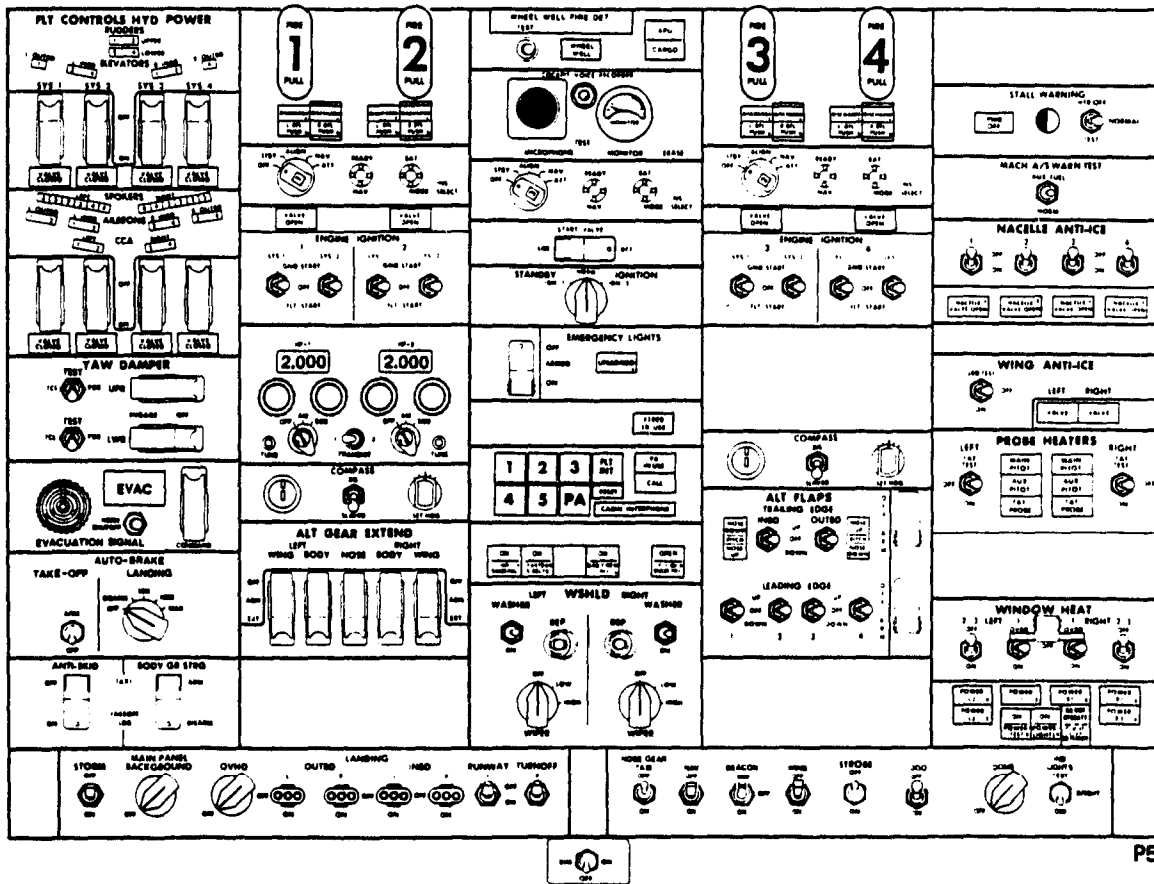
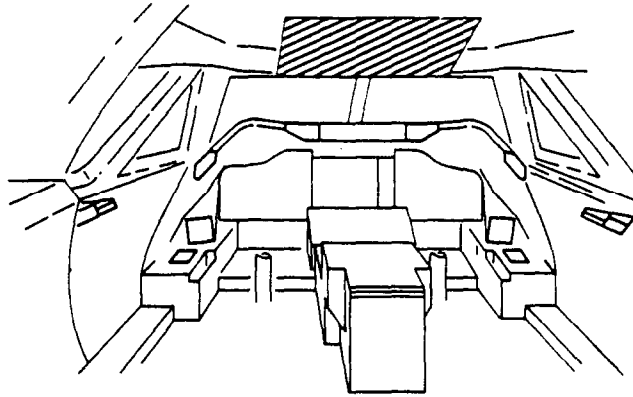

P5

FIGURE 1 - PILOTS' OVERHEAD PANEL

TMA 85555/R/4479R

END

EFF.

N151UA-52UA

MM 747-200  
CONFIG. 1

31-12-11  
PAGE 1  
JAN 29/91



# UNITED AIRLINES

## PILOTS' OVERHEAD PANEL - DESCRIPTION AND OPERATION

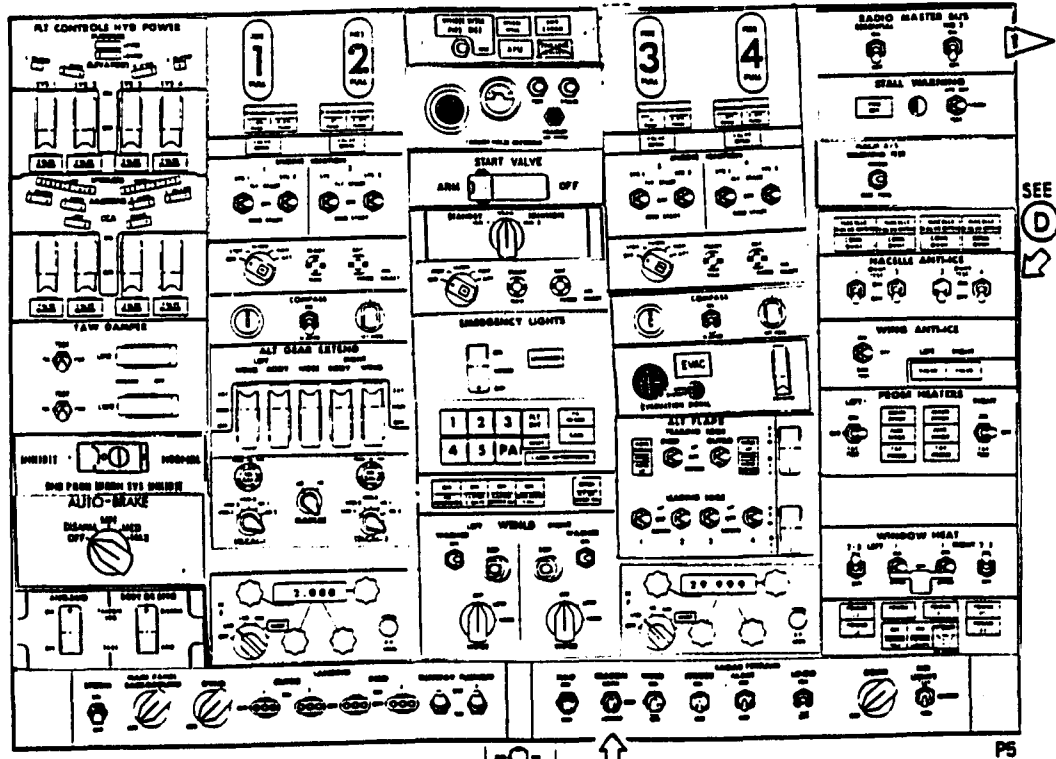
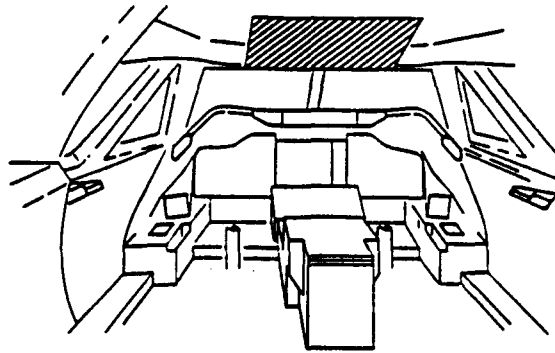

1 RADIO MASTER BUS ON  
N161UA-65UA

2 "STATOR VALVE OPEN"  
LABELED "INOP" ON  
AIRPLANES INCORPORATING  
SB 75-2018

N161UA-63UA

A

N161UA-65UA

D

FIGURE 1 (SHEET 1 OF 2) - PILOT'S OVERHEAD PANEL

TMA 0277/K/4480R

CONTINUED

EFF.

N158UA-65UA  
Before COA 8-4216

MM 747-200  
CONFIG. 2

31-12-11  
PAGE 1  
FEB 02/94

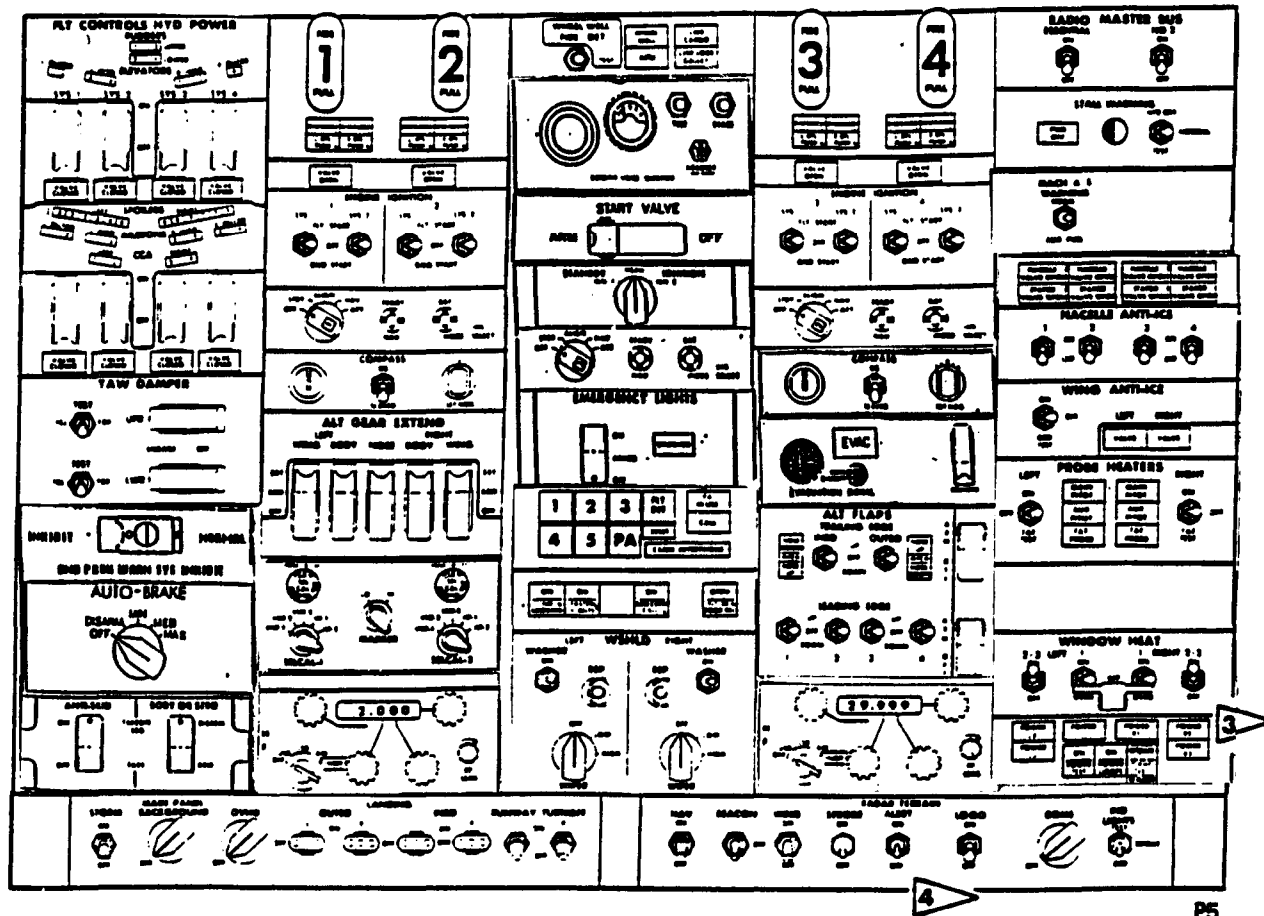

- 3 "RADAR TERRAIN ALERT" SWITCH  
INSTALLED ON N158UA-600A
- 4 "STATOR VALVE OPEN" LABELED  
"INOP" ON AIRPLANES INCORPORATING  
SB 75-2018

FIGURE 1 (SHEET 2 OF 2) - PILOT'S OVERHEAD PANEL

TMA 0277/K/4480R

END

EFF.

N158UA-65UA  
Before COA 8-4216

MM 747-200  
CONFIG. 2

31-12-11  
PAGE 2  
FEB 02/94

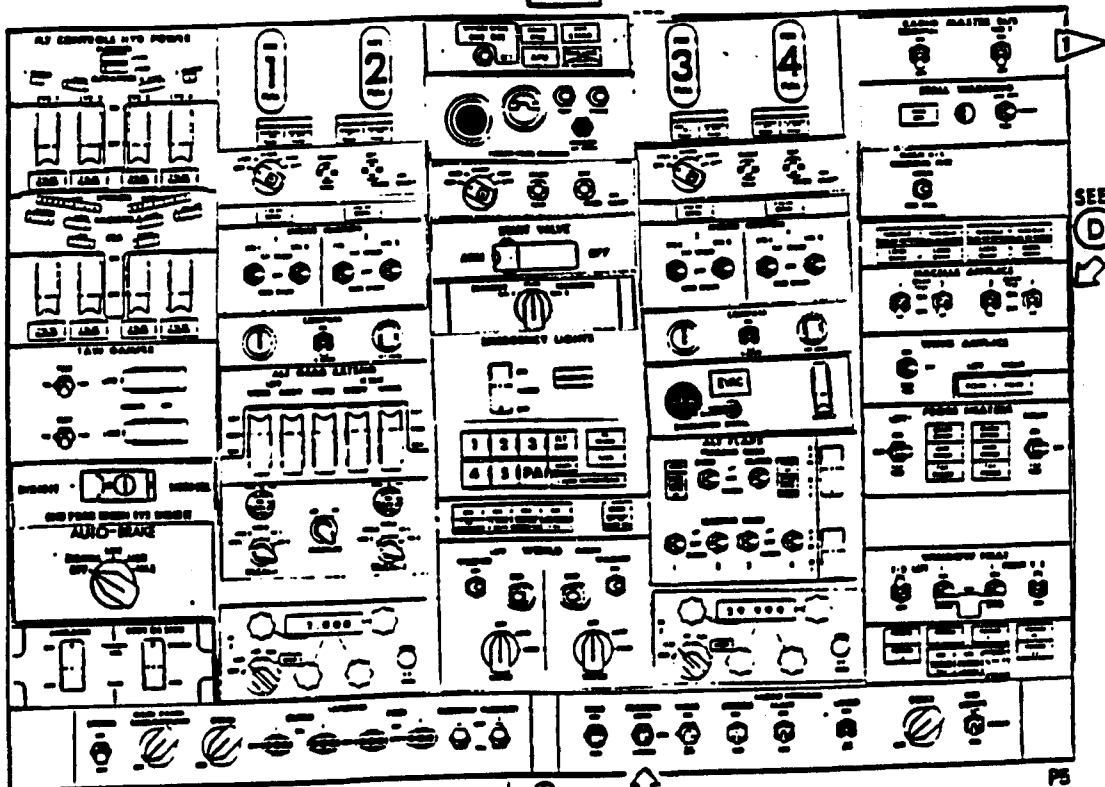
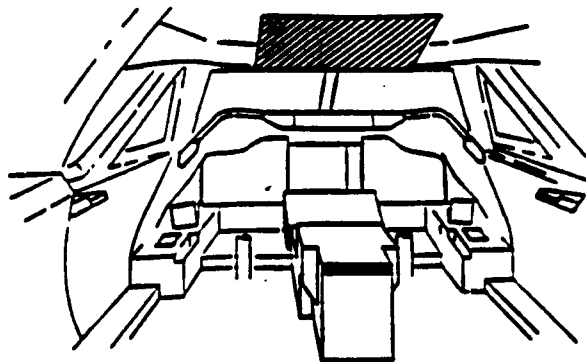

1 RADIO MASTER BUS ON  
N161UA-65UA

2 "STATOR VALVE OPEN"  
LABELED "TOP" ON  
AIRPLANES INCORPORATING  
SB 75-2018

N161UA-63UA

(A)

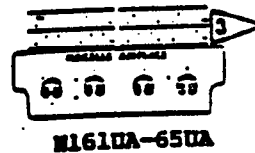

(D)

FIGURE 1 (SHEET 1 OF 2) - PILOT'S OVERHEAD PANEL

TMA 0277/K/6518R

CONTINUED

EFF.

N158UA-65UA  
After COA 8-4216

MM 747-200  
CONFIG. 3

31-12-11  
PAGE 1  
FEB 02/94

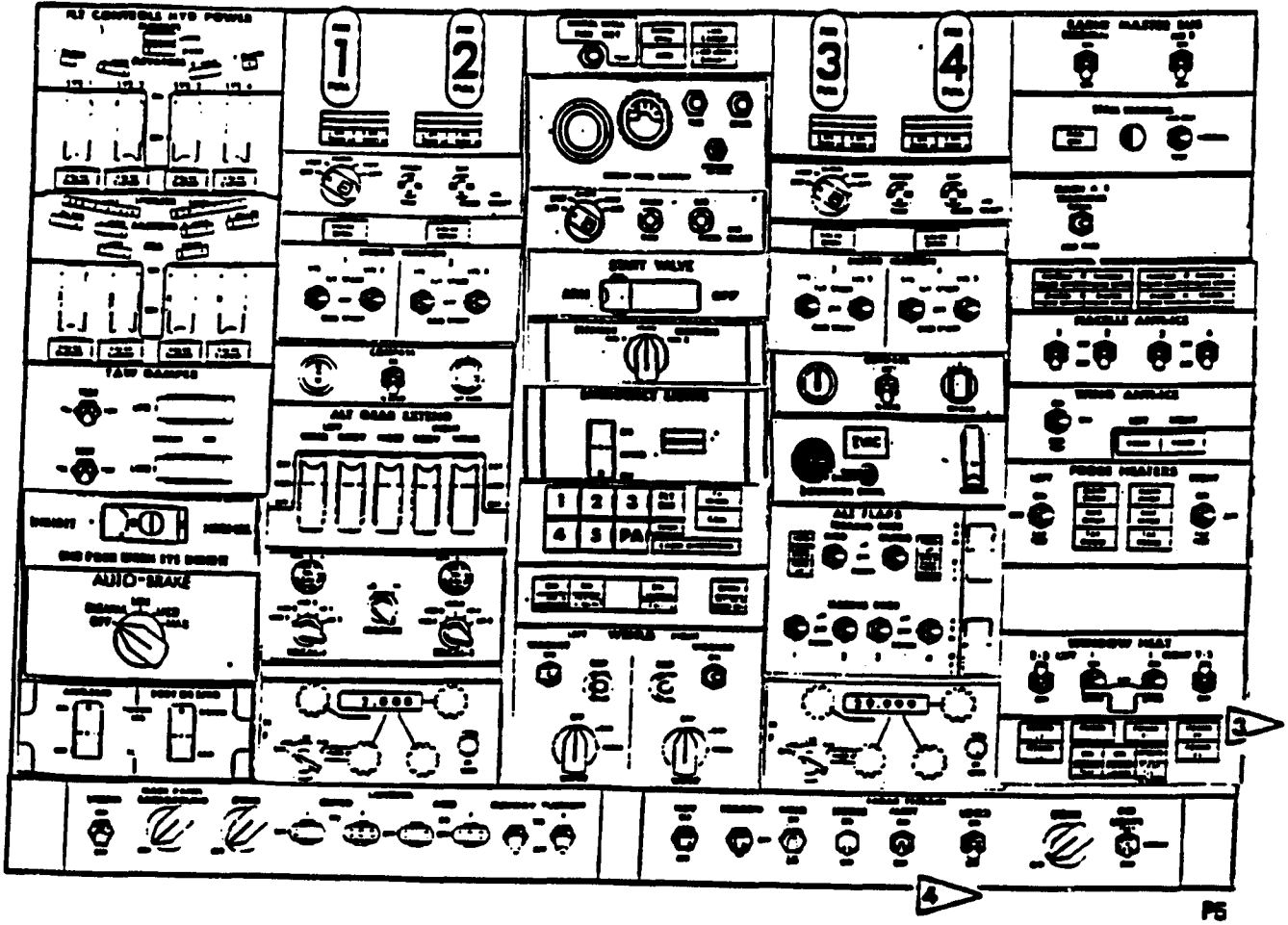

- 3

**"RADAR TERRAIN ALERT" SWITCH  
INSTALLED ON N158UA-600A**
- 4

**"STATOR VALVE OPEN" LABELED  
"NOP" ON AIRPLANES INCORPORATING  
SB 75-2018**

FIGURE 1 (SHEET 2 OF 2) - PILOT'S OVERHEAD PANEL

TMA 0277/K/6518R

END

EFF.

N158UA-65UA  
After COA 8-4216

MM 747-200  
CONFIG. 3

31-12-11  
PAGE 2  
FEB 02/94

## CAPTAIN'S AND FIRST OFFICER'S AUXILIARY PANELS - DESCRIPTION AND OPERATION

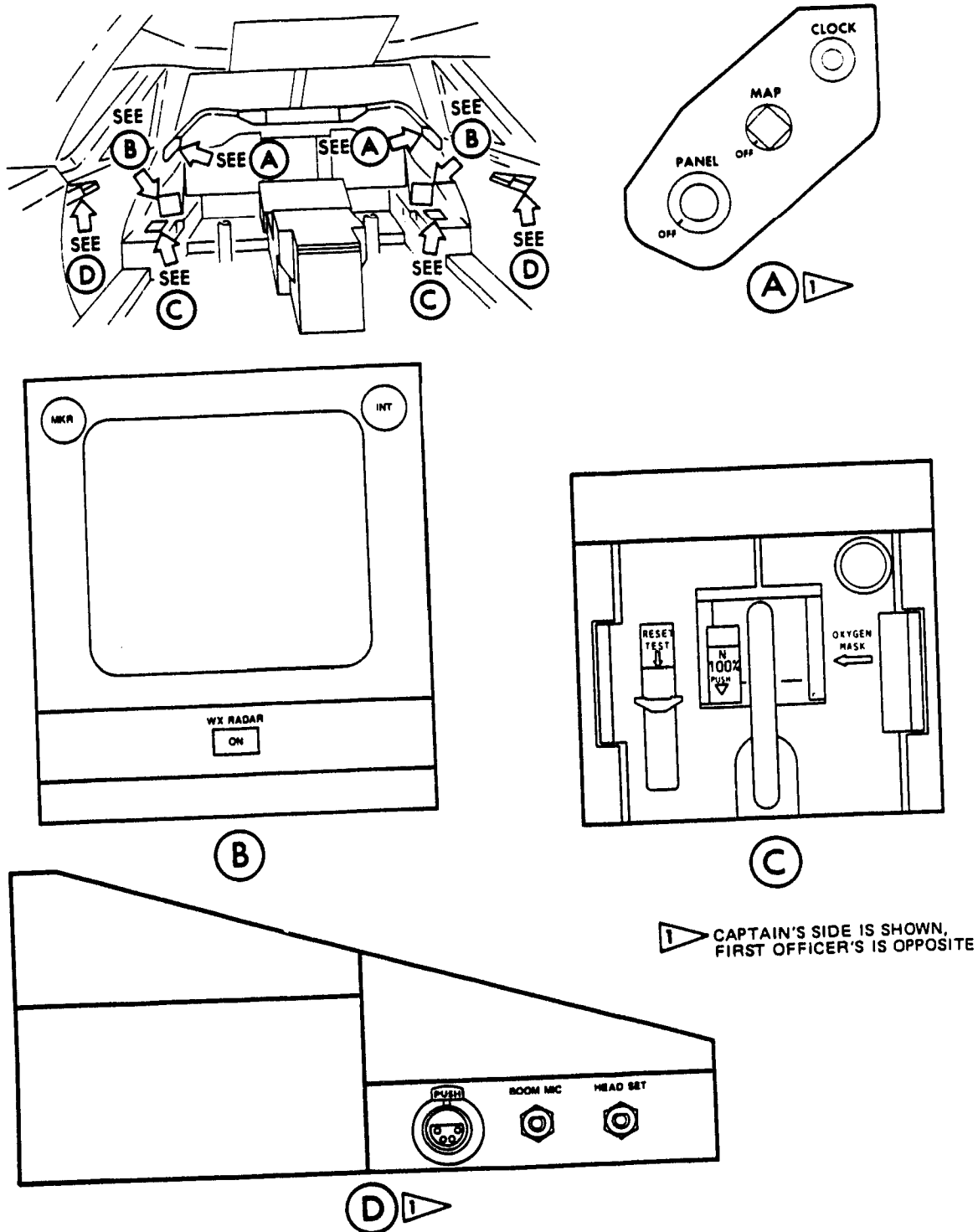

FIGURE 1 - CAPTAIN'S AND FIRST OFFICER'S AUXILIARY PANELS

TMA 85555/R/4481R

END

EFF.

N151UA-52UA

MM 747-200  
CONFIG. 1

31-13-20  
PAGE 1  
JAN 29/91

## CAPTAIN'S AND FIRST OFFICER'S AUXILIARY PANELS - DESCRIPTION AND OPERATION

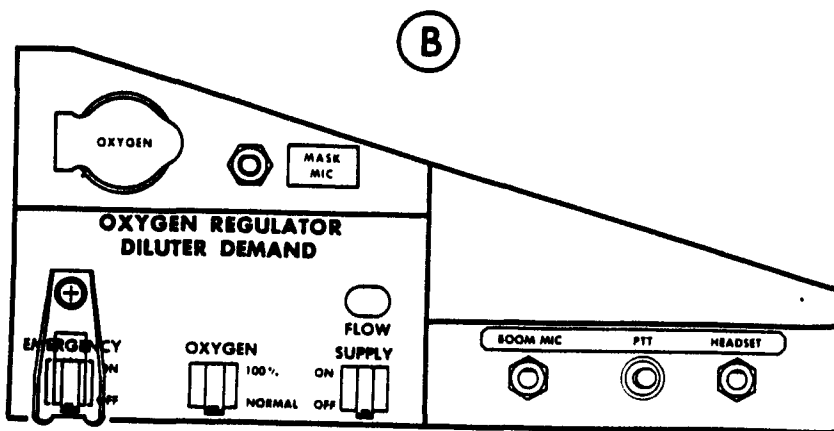
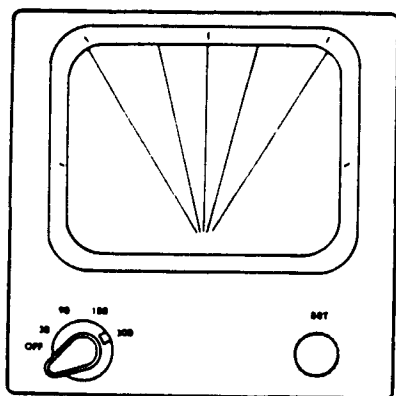
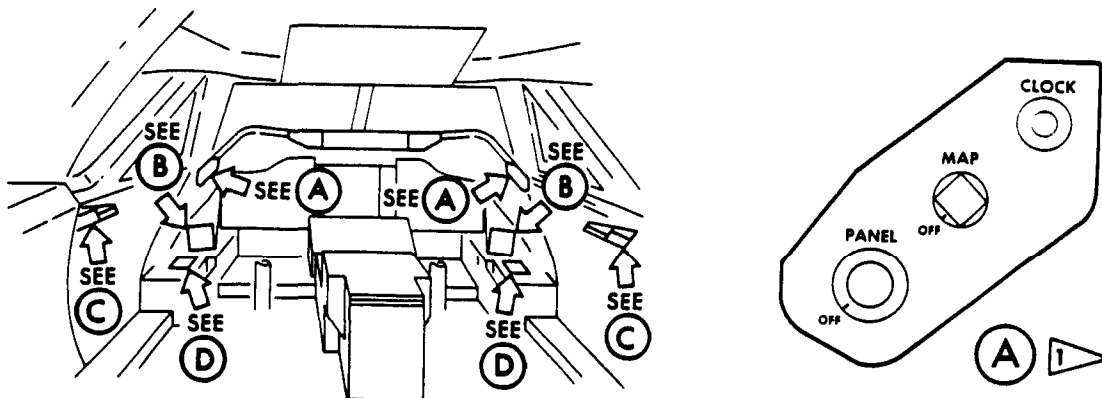

▶ CAPTAIN'S SIDE IS SHOWN,  
FIRST OFFICER'S IS OPPOSITE

FIGURE 1 - CAPTAIN'S AND FIRST OFFICER'S AUXILIARY PANELS

TMA 85555/R/4482R

END

EFF.

N158UA-65UA

MM 747-200  
CONFIG. 2

31-13-20  
PAGE 1  
JAN 29/91

## FLIGHT ENGINEER'S PANEL, UPPER LEFT - DESCRIPTION AND OPERATION

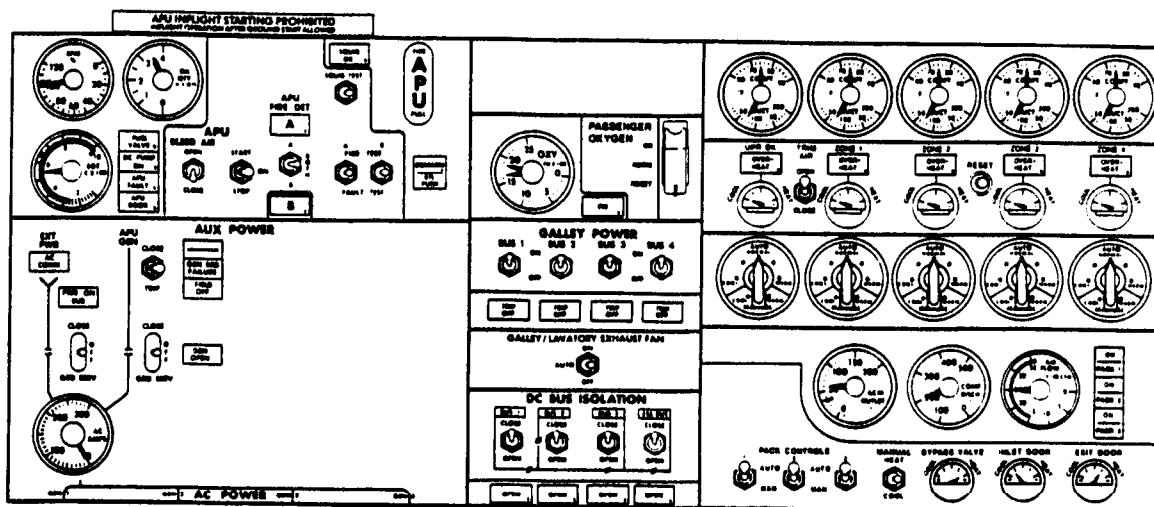
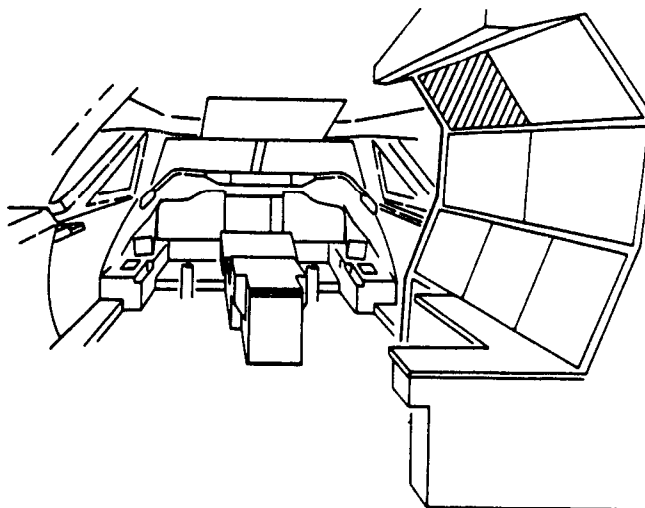

P4

FIGURE 1 - FLIGHT ENGINEER'S PANEL, UPPER LEFT

TMA 85555/R/4483R

END

EFF.

N151UA-52UA

MM 747-200  
CONFIG. 1

31-14-11  
PAGE 1  
JAN 29/91

## FLIGHT ENGINEER'S PANEL, UPPER LEFT - DESCRIPTION AND OPERATION

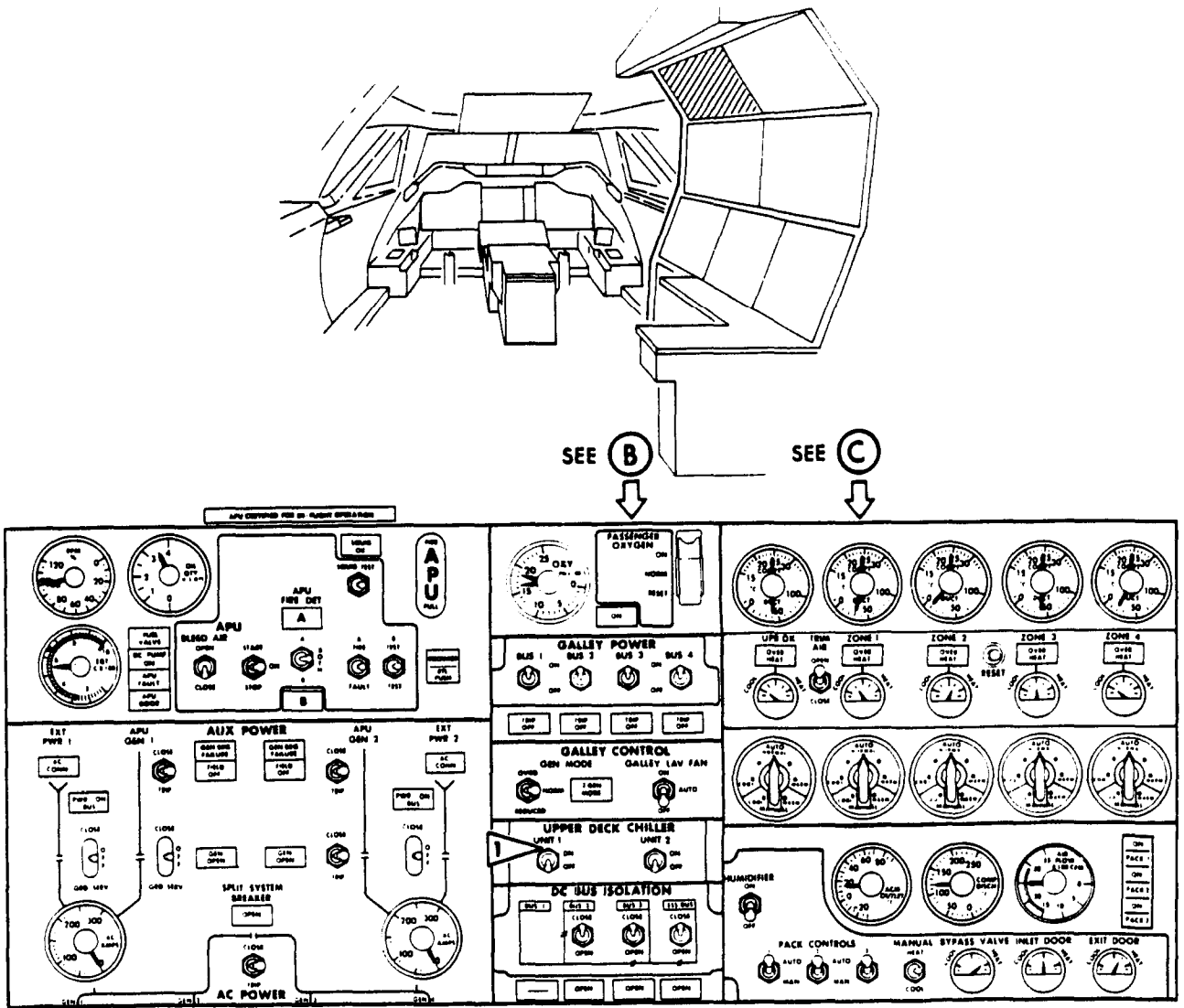

**B**

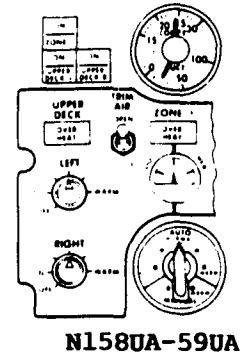

**C**

**1** N161UA-65UA

FIGURE 1 - FLIGHT ENGINEER'S PANEL, UPPER LEFT,

TMA 85555/R/4484R

END

EFF

N158UA-65UA

MM 747-200  
CONFIG. 2

31-14-11  
PAGE 1  
JAN 29/91









## FLIGHT ENGINEER'S PANEL, CENTER LEFT - DESCRIPTION AND OPERATION

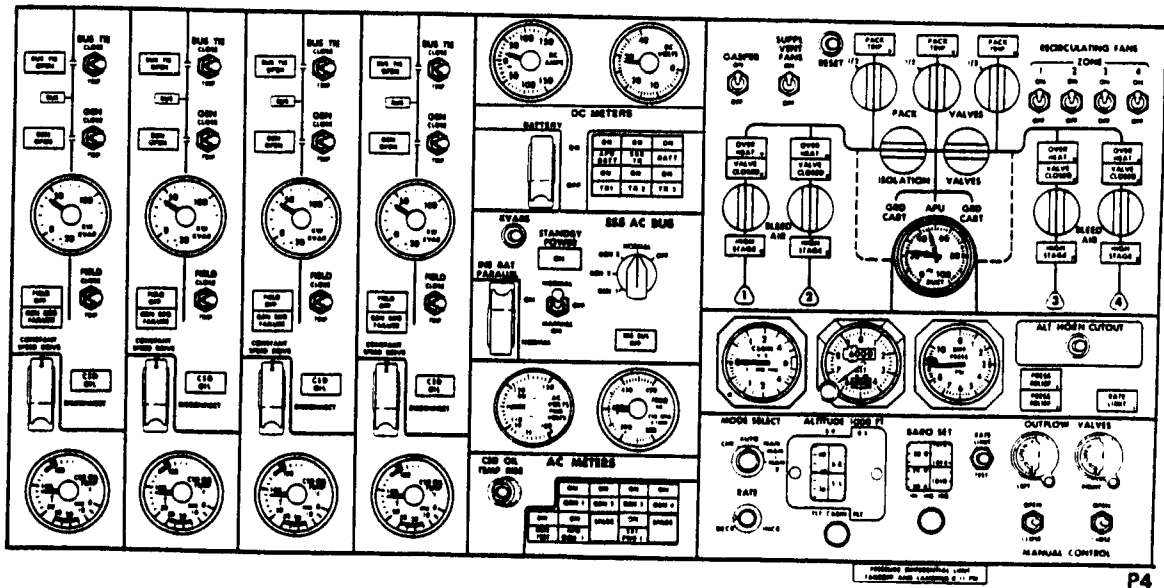
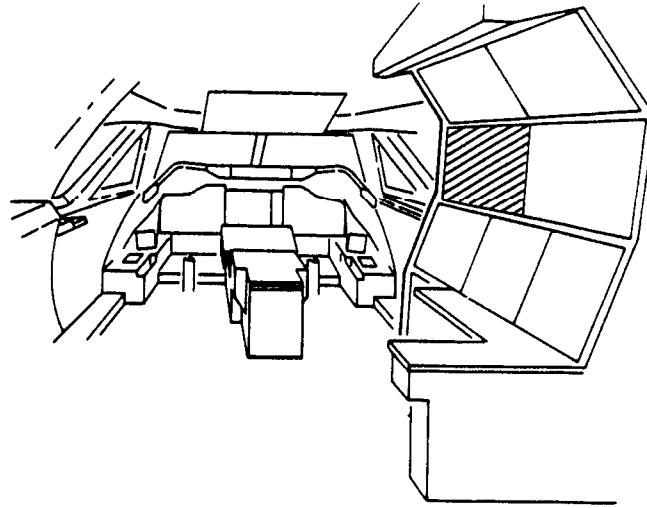

FIGURE 1 - FLIGHT ENGINEER'S PANEL, CENTER LEFT

TMA 85555/R/4722R

END

EFF.

N151UA-52UA

MM 747-200  
CONFIG. 1

31-14-21  
PAGE 1  
JAN 29/91

## FLIGHT ENGINEER'S PANEL CENTER LEFT - DESCRIPTION AND OPERATION

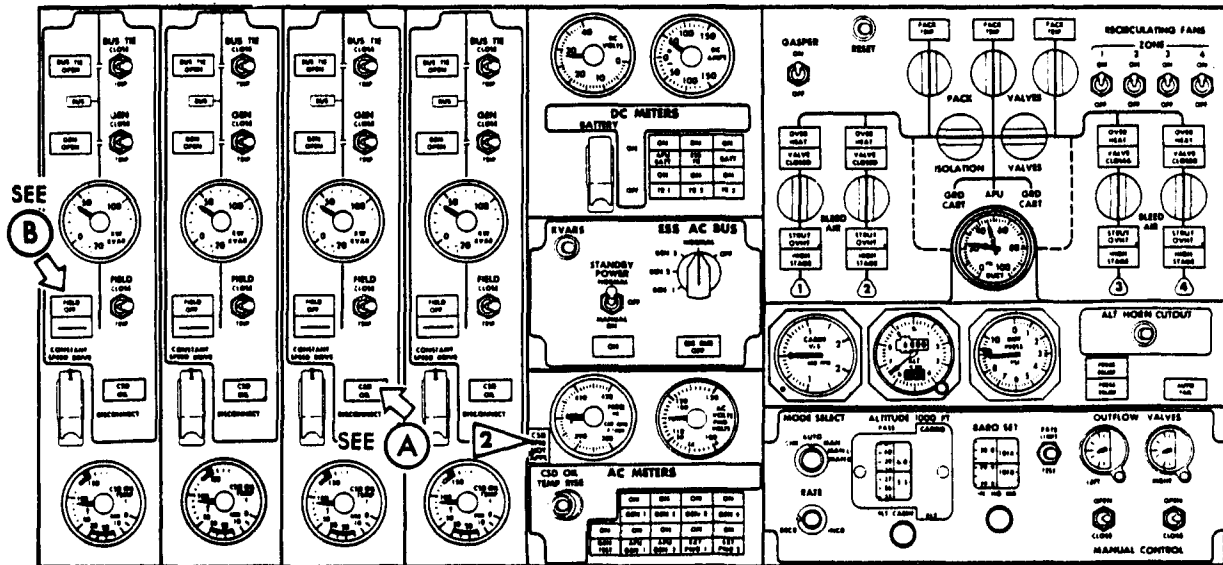
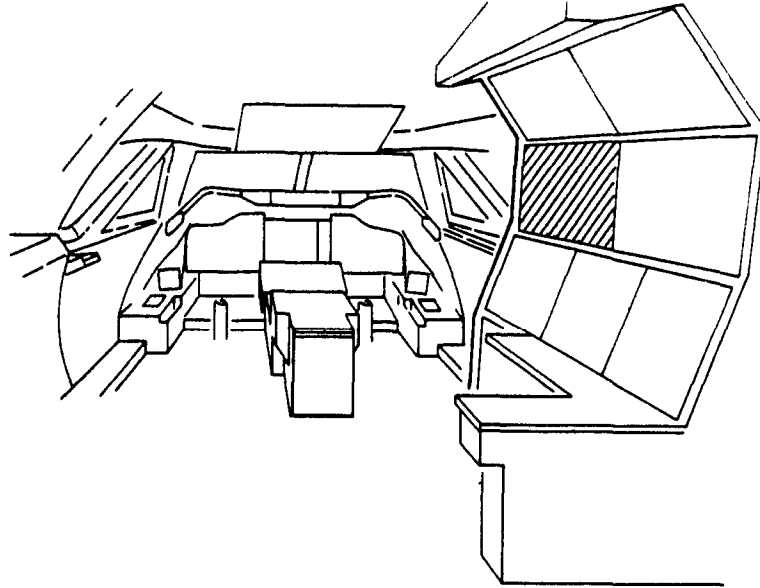

N158UA-61UA  
(4 PLACES)

(A)

N158UA-65UA  
(4 PLACES)

(B)

THE INSTRUMENT FACES ARE ONLY REPRESENTATIVE AND  
MAY NOT EXACTLY REFLECT THE LATEST CONFIGURATION

FIGURE 1 - FLIGHT ENGINEER'S PANEL, CENTER LEFT

TMA 85555/R/4723R

END

EFF

N158UA-65UA

MM 747-200  
CONFIG. 2

31-14-21  
PAGE 1  
JAN 29/91

## FLIGHT ENGINEER'S PANEL, CENTER RIGHT - DESCRIPTION AND OPERATION

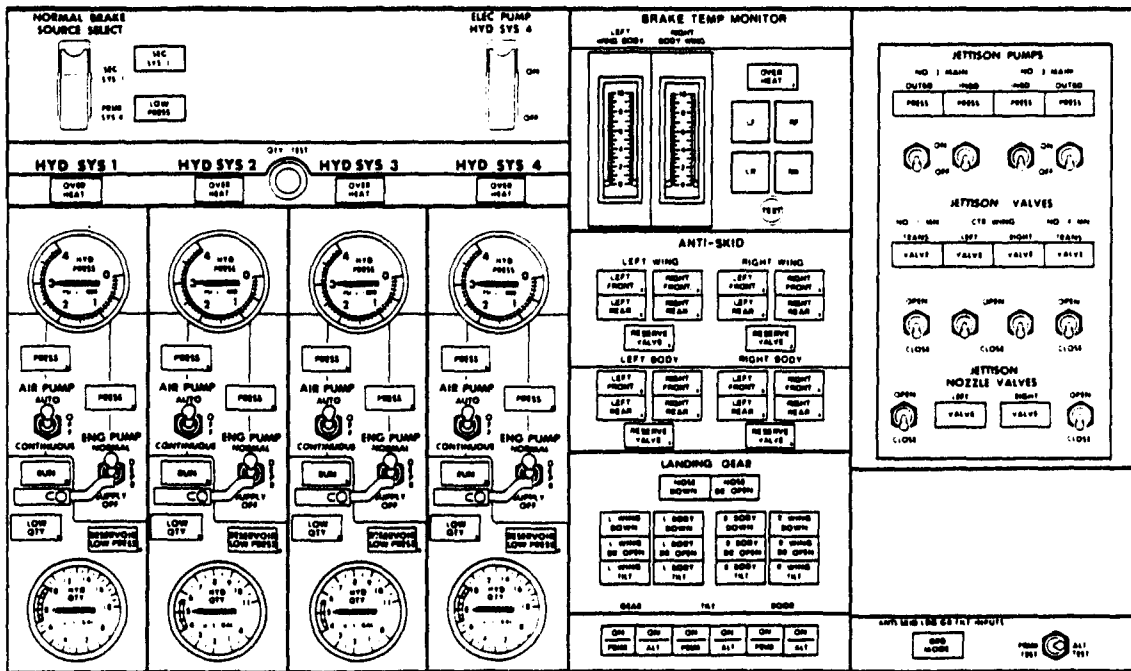
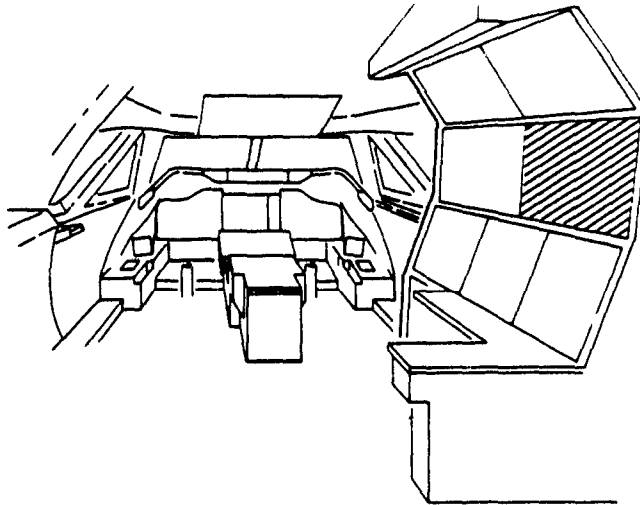

P4

FIGURE 1 - FLIGHT ENGINEER'S PANEL, CENTER RIGHT

TMA 85555/R/4724R

END

EFF.

N151UA-52UA

MM 747-200  
CONFIG. 1

31-14-26  
PAGE 1  
JAN 29/91

## FLIGHT ENGINEER'S PANELS, CENTER RIGHT - DESCRIPTION AND OPERATION

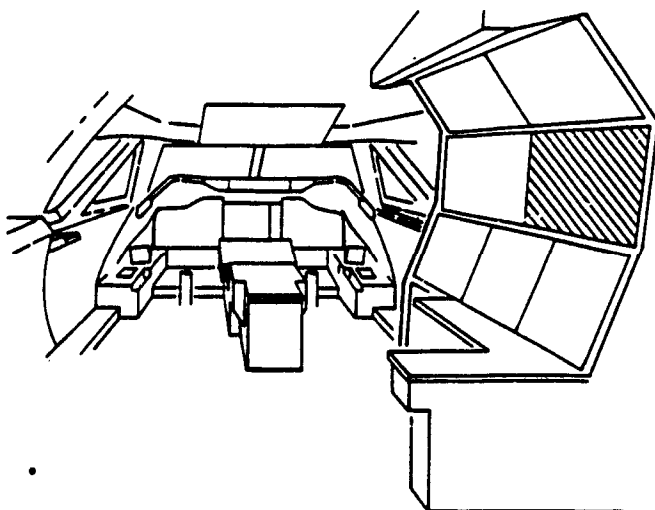

1 ▽ HYD TEMP INDICATORS ON N158UA-65UA

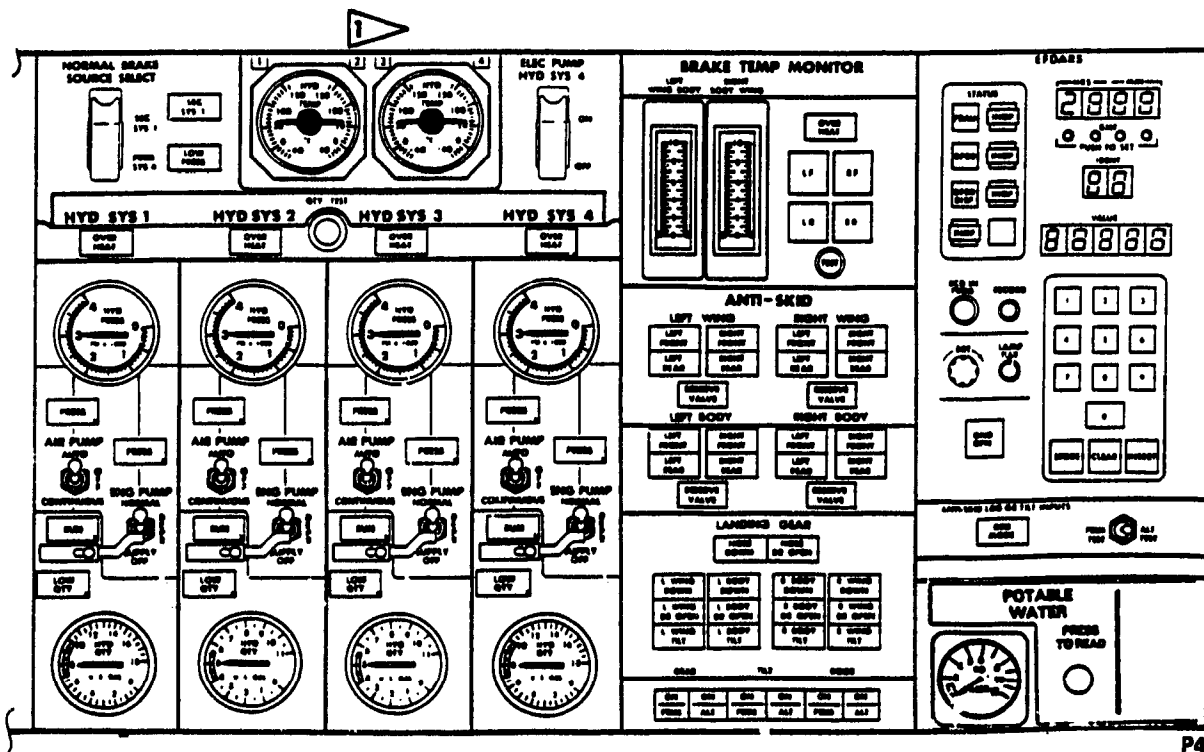

P4

FIGURE 1 - FLIGHT ENGINEER'S PANEL, CENTER RIGHT

TMA 4391/R/4725R

END

EFF.

N158UA-65UA

MM 747-200  
CONFIG. 2

31-14-26  
PAGE 1  
SEP 29/93

## FLIGHT ENGINEER'S PANEL, LOWER LEFT AND RIGHT - DESCRIPTION AND OPERATION

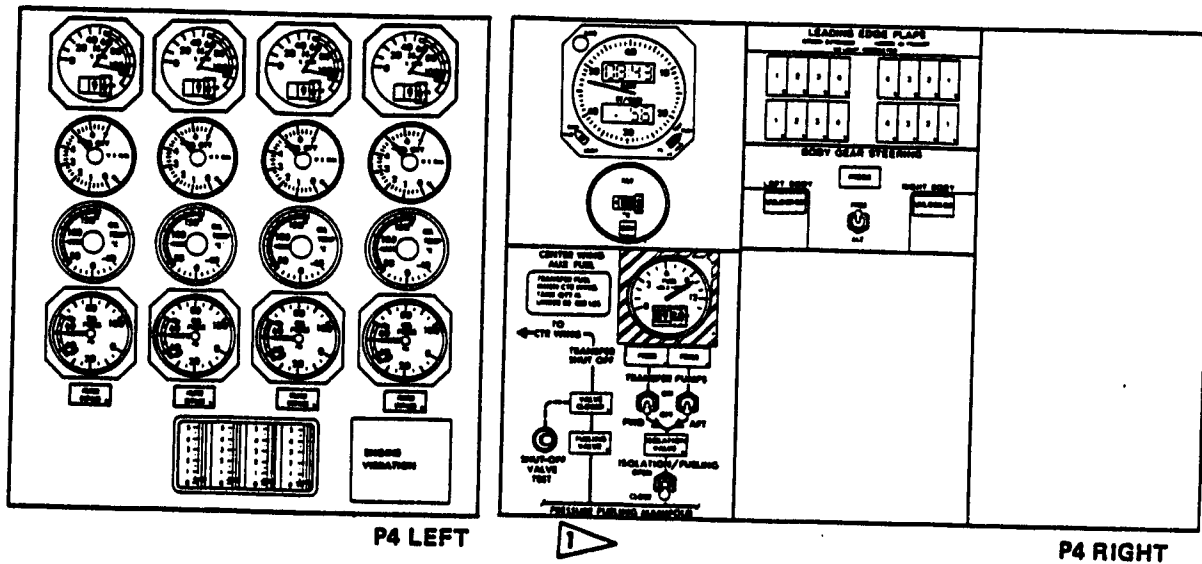
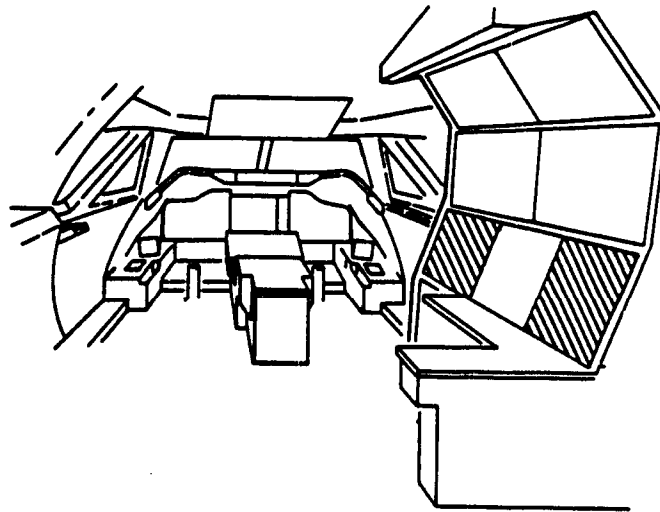

**1** BODY FUEL SYSTEM LABELED INOPERATIVE DURING OPERATIONS WITH BODY FUEL TANK REMOVED

FIGURE 1 - FLIGHT ENGINEER'S PANEL, LOWER LEFT AND RIGHT

TMA 85555/R/4726R

END

EFF.

N151UA-52UA

MM 747-200  
CONFIG. 1

31-14-31  
PAGE 1  
JAN 29/91





## FLIGHT ENGINEER'S PANEL, LOWER LEFT AND RIGHT - DESCRIPTION AND OPERATION

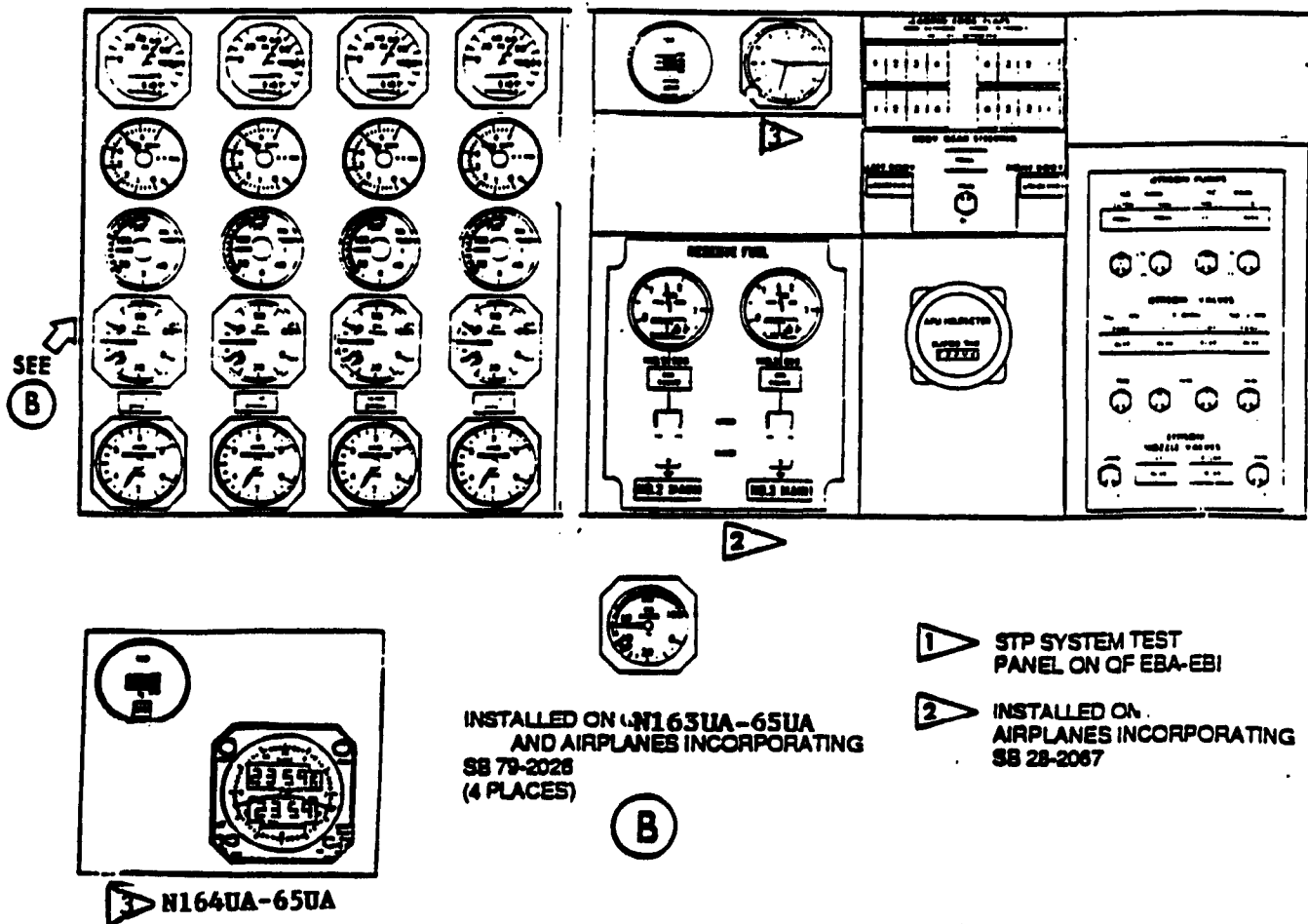
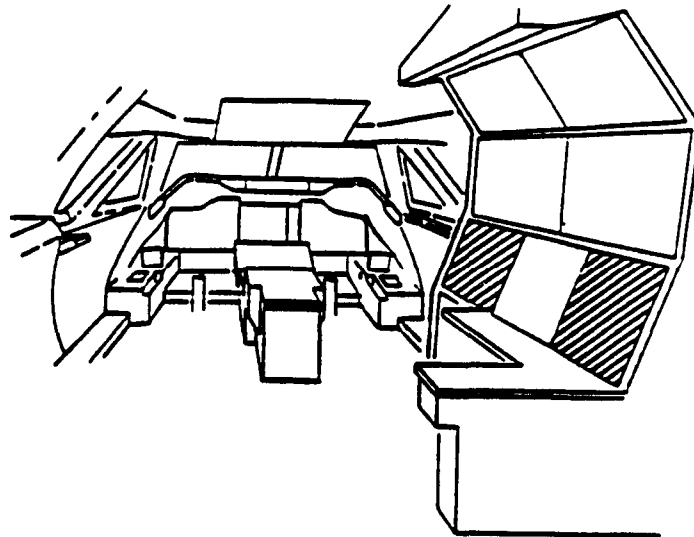

FIGURE 1 - FLIGHT ENGINEER'S PANEL, LOWER LEFT AND RIGHT

TMA 0277/K/6520R

END

EFF.

N158UA-65UA  
After COA 8-4216

MM 747-200  
CONFIG. 3

31-14-31  
PAGE 1  
FEB 02/94



## FLIGHT ENGINEER'S PANEL, LOWER CENTER - DESCRIPTION AND OPERATION

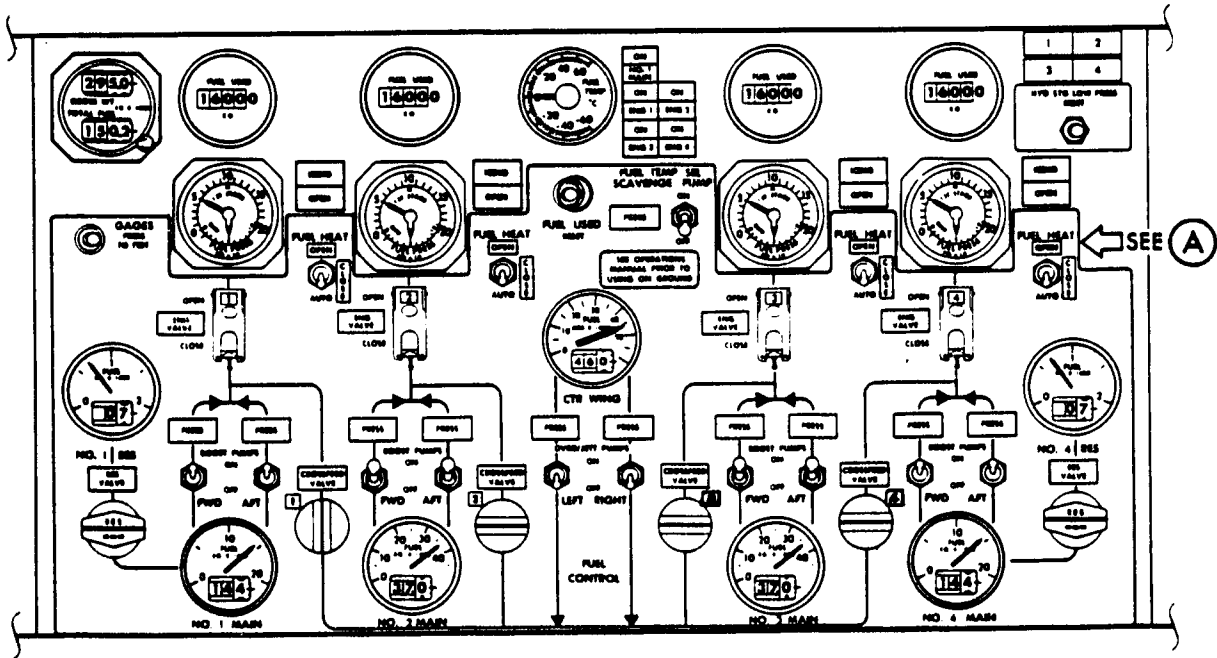
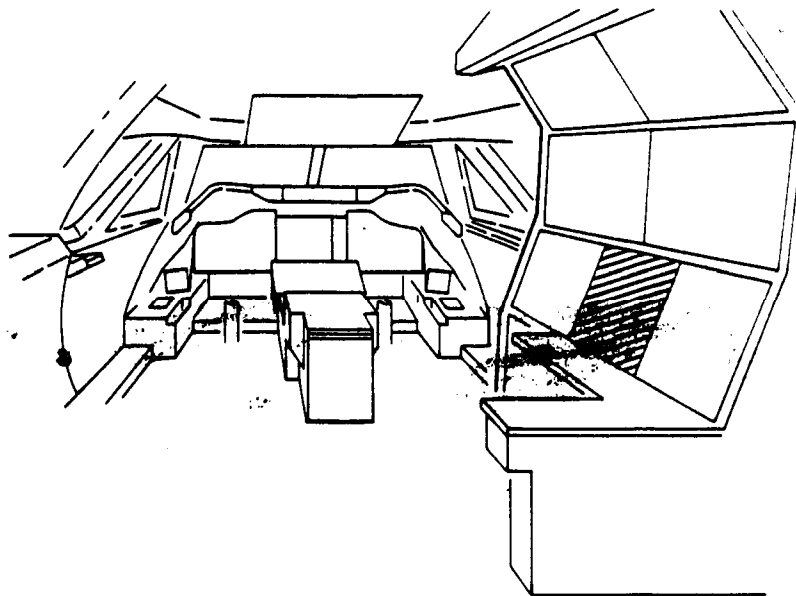

FUEL HEAT  
  
**N158UA-65UA**  
 (4 PLACES)  

THE INSTRUMENT FACES ARE ONLY REPRESENTATIVE AND MAY NOT EXACTLY REFLECT THE LATEST CONFIGURATION

FIGURE 1 - FLIGHT ENGINEER'S PANEL, LOWER CENTER

TMA 85555/R/4729R

END

EFF.

N158UA-65UA

MM 747-200  
 CONFIG. 2

31-14-36  
 PAGE 1  
 JAN 29/91

## FLIGHT ENGINEER'S AUXILIARY PANELS - DESCRIPTION AND OPERATION

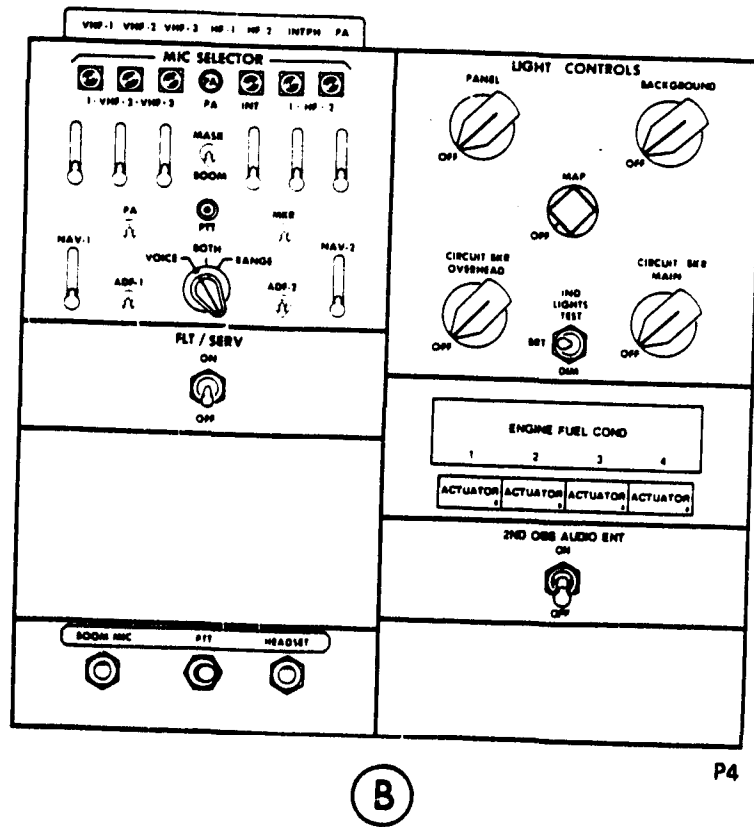
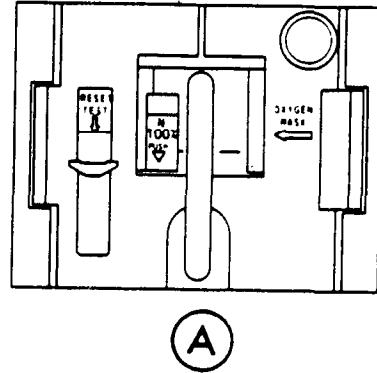
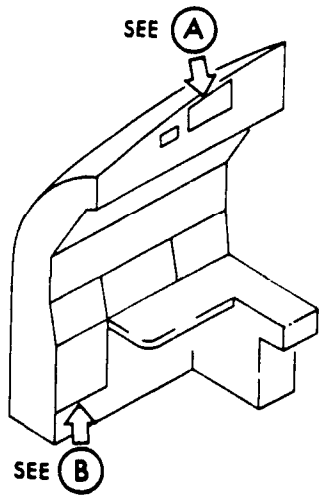

FIGURE 1 - FLIGHT ENGINEER'S AUXILIARY PANELS

TMA 85555/0/4528R

END

EFF

N151UA-52UA

MM 747-200  
CONFIG. 1

31-14-41  
PAGE 1  
JAN 29/91

# UNITED AIRLINES

## FLIGHT ENGINEER'S AUXILIARY PANELS - DESCRIPTION AND OPERATION

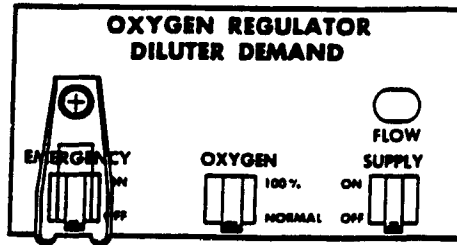
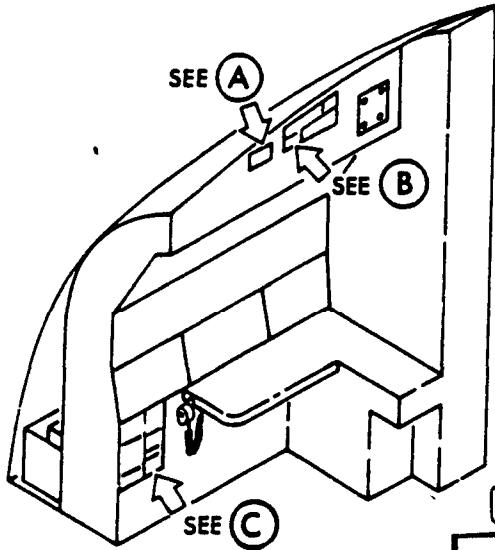

(A)

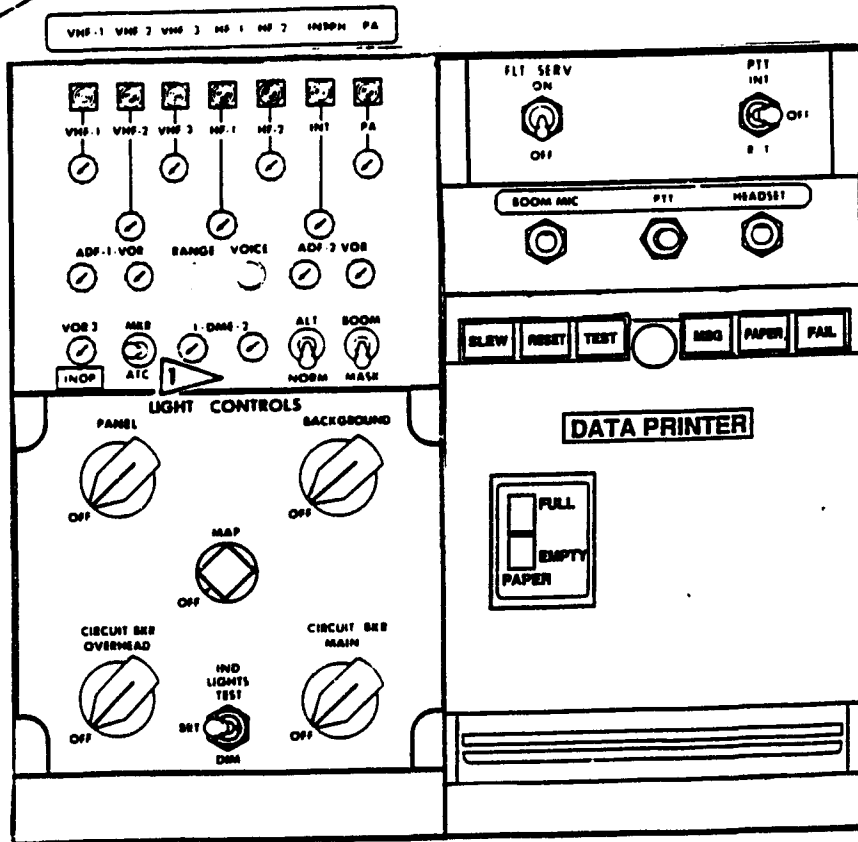

(C)

1 ATC SWITCH INOPERATIVE ON N164UA-65UA

THE INSTRUMENT PAGES ARE ONLY REPRESENTATIVE AND MAY NOT EXACTLY REFLECT THE LATEST CONFIGURATION

FIGURE 1 (SHEET 1 OF 3) - FLIGHT ENGINEER'S AUXILIARY PANELS

TMA 4391/R/4529R

CONTINUED

EFF.

N158UA-65UA

MM 747-200  
CONFIG. 2

31-14-41  
PAGE 1  
SEP 29/93

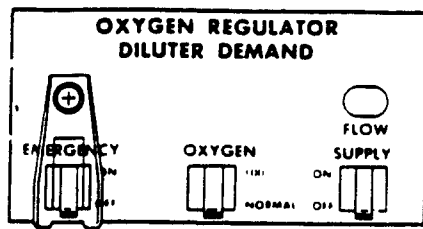

(A)

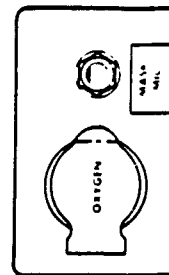

(B)

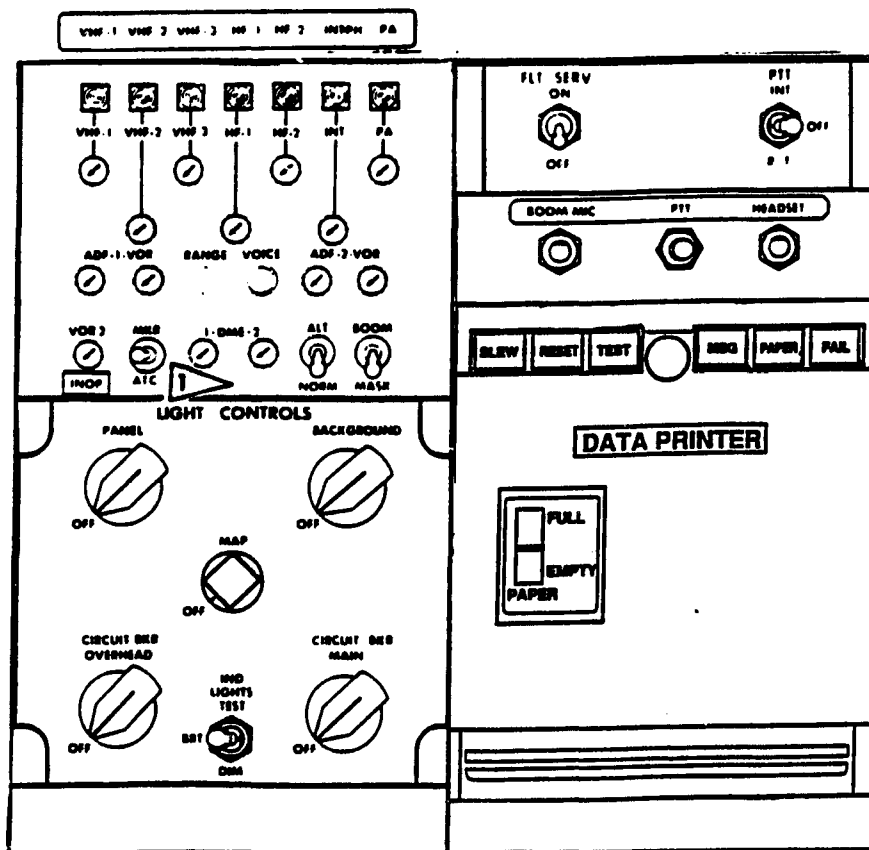

(C)

P4

THE INSTRUMENT FACES ARE ONLY REPRESENTATIVE AND MAY NOT EXACTLY REFLECT THE LATEST CONFIGURATION

FIGURE 1 (SHEET 2 OF 3) - FLIGHT ENGINEER'S AUXILIARY PANELS

TMA 4391/R/4529R

CONTINUED

EFF.

N158UA-65UA

MM 747-200  
CONFIG. 2

31-14-41  
PAGE 2  
SEP 29/93

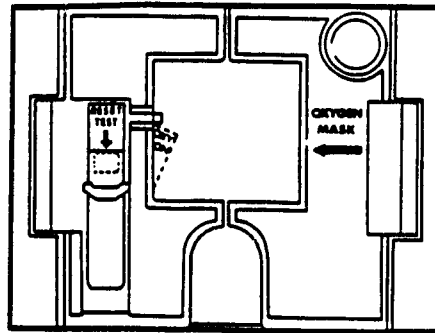

(A)

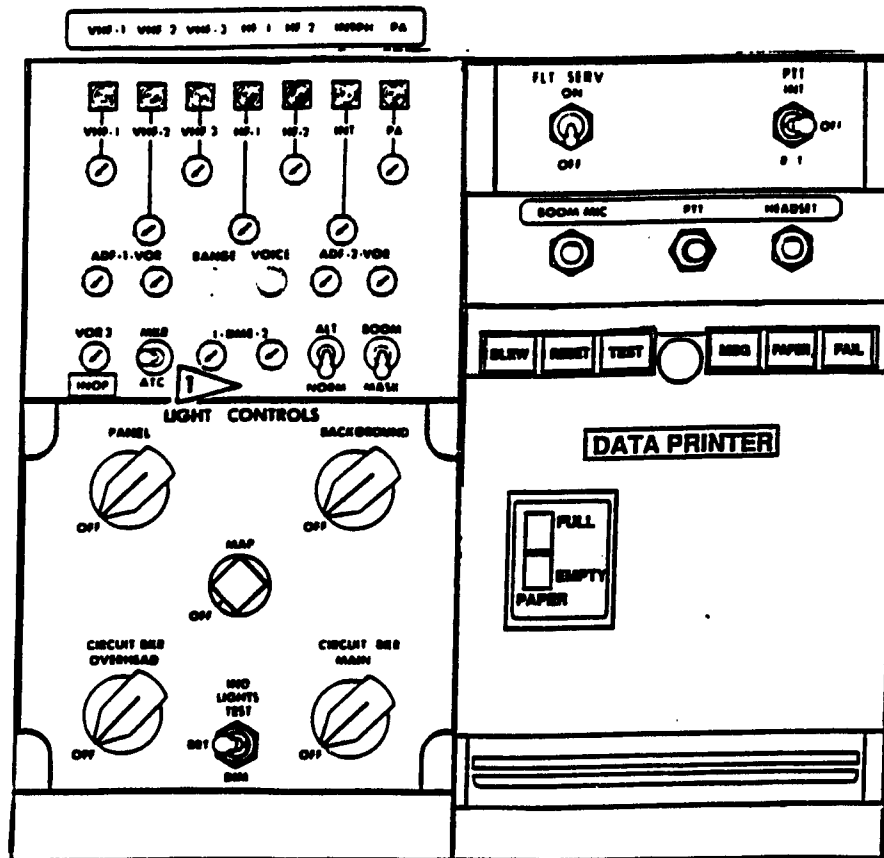

P4

(C)

FIGURE 1 (SHEET 3 OF 3) - FLIGHT ENGINEER'S AUXILIARY PANELS

TMA 4391/R/4529R

END

EFF.

N158UA-65UA

MM 747-200  
CONFIG. 2

31-14-41  
PAGE 3  
SEP 29/93



## OBSERVERS' PANELS - DESCRIPTION AND OPERATION

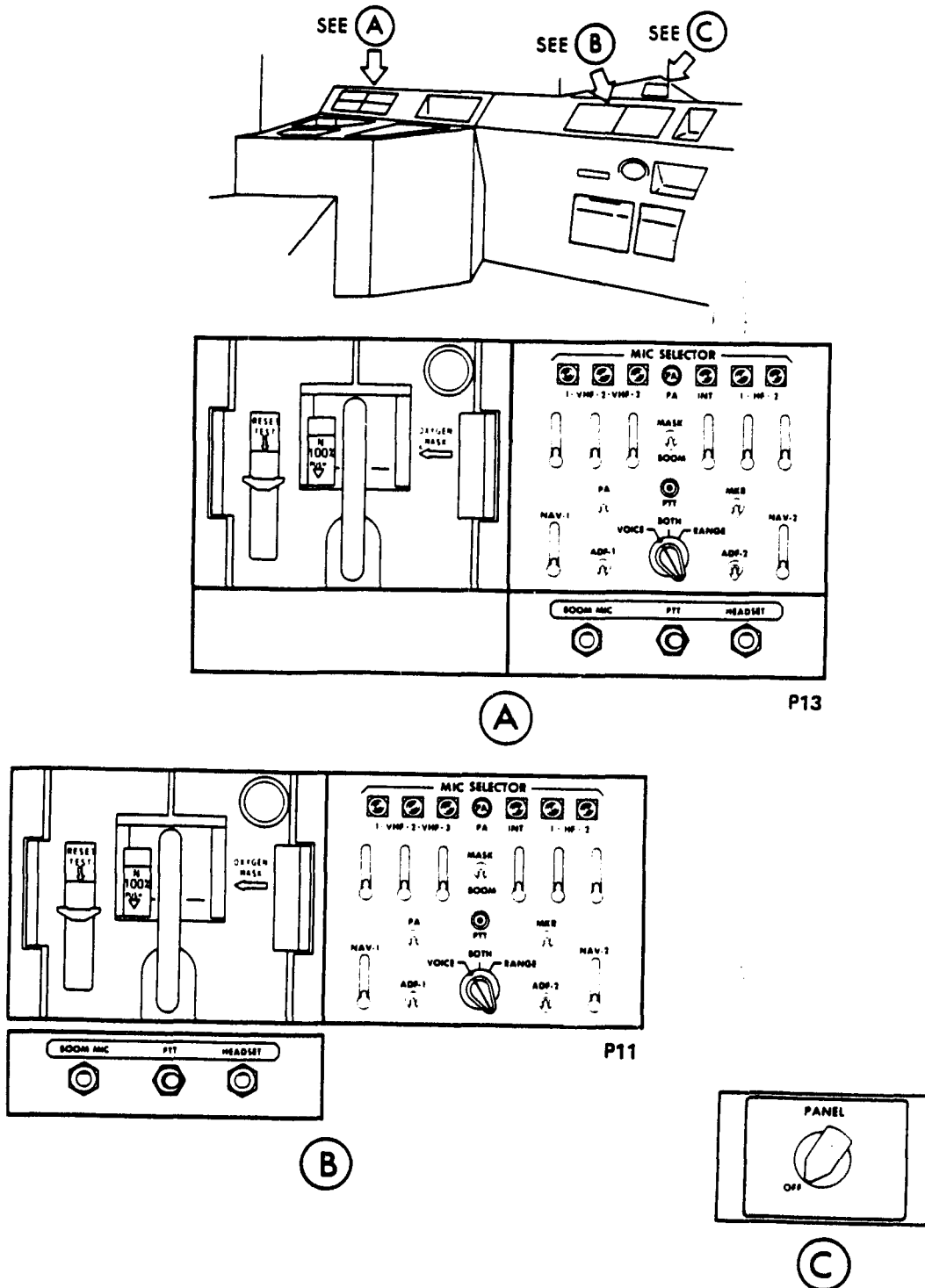

FIGURE 1 - OBSERVERS' PANELS

TMA 85555/0/4530R

END

EFF.

N151UA-52UA

MM 747-200  
CONFIG. 1

31-15-11  
PAGE 1  
JAN 29/91

## OBSERVERS' PANELS - DESCRIPTION AND OPERATION

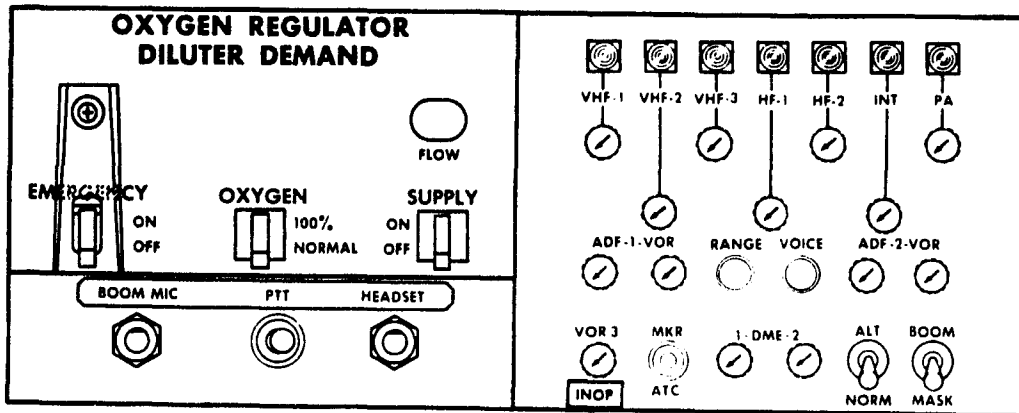
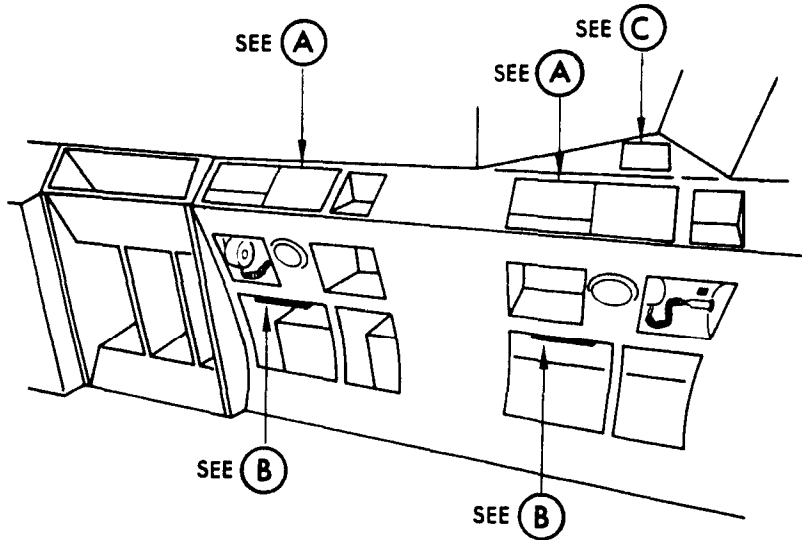

(A)

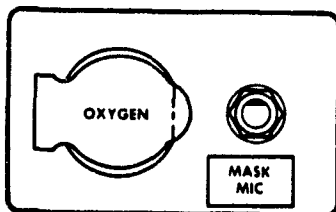

(B)

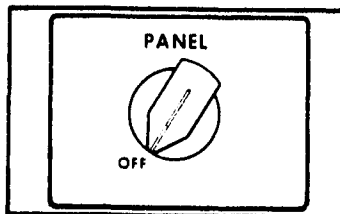

(C)

THE INSTRUMENT FACES ARE ONLY REPRESENTATIVE AND MAY NOT EXACTLY REFLECT THE LATEST CONFIGURATION

EFF: N158UA-60UA

FIGURE 1 (SHEET 1 OF 2) - OBSERVERS' PANELS

TMA 8555/0/4531R

CONTINUED

EFF.

N158UA-65UA

MM 747-200  
CONFIG. 2

31-15-11  
PAGE 1  
JAN 29/91

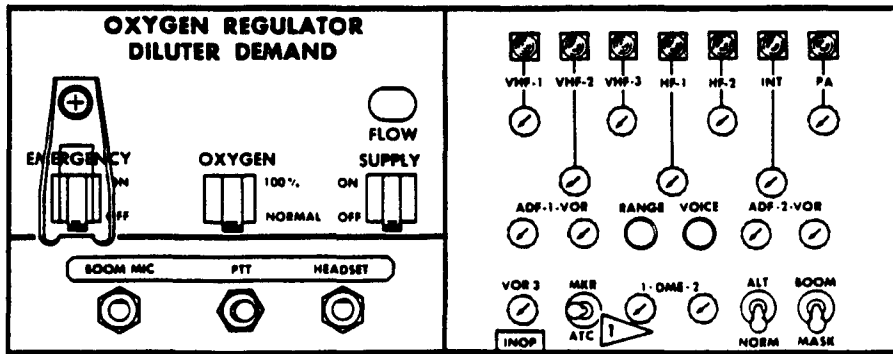
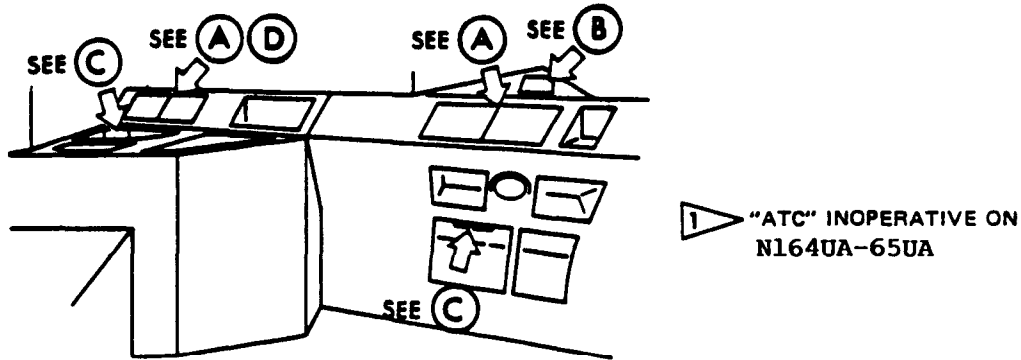

(A)

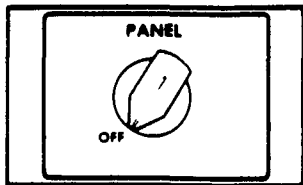

(B)

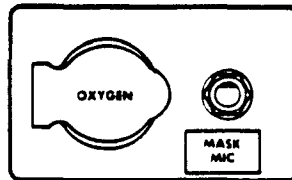

(C)

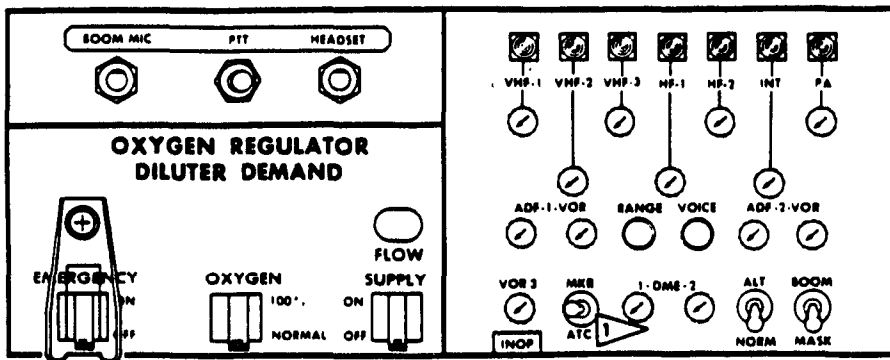

OF EBM-ECC ONLY

(D)

THE INSTRUMENT FACES ARE ONLY REPRESENTATIVE AND MAY NOT EXACTLY REFLECT THE LATEST CONFIGURATION

EFF: N161UA-65UA

FIGURE 1 (SHEET 2 OF 2) - OBSERVERS' PANELS

TMA 85555/0/4531R

END

EFF

N158UA-65UA

MM 747-200  
CONFIG. 2

31-15-11  
PAGE 2  
JAN 29/91